











Nature.
June 11, 1903.]

11/11
S.V.

57854

21

98
Nature

A WEEKLY

ILLUSTRATED JOURNAL OF SCIENCE



Nature,
June 11, 1908.]

Nature

A WEEKLY

ILLUSTRATED JOURNAL OF SCIENCE

VOLUME LXXVII

NOVEMBER, 1907, to APRIL, 1908

*"To the solid ground
Of Nature trusts the mind which builds for aye."*—WORDSWORTH

London

MACMILLAN AND CO., LIMITED
NEW YORK: THE MACMILLAN COMPANY

202249

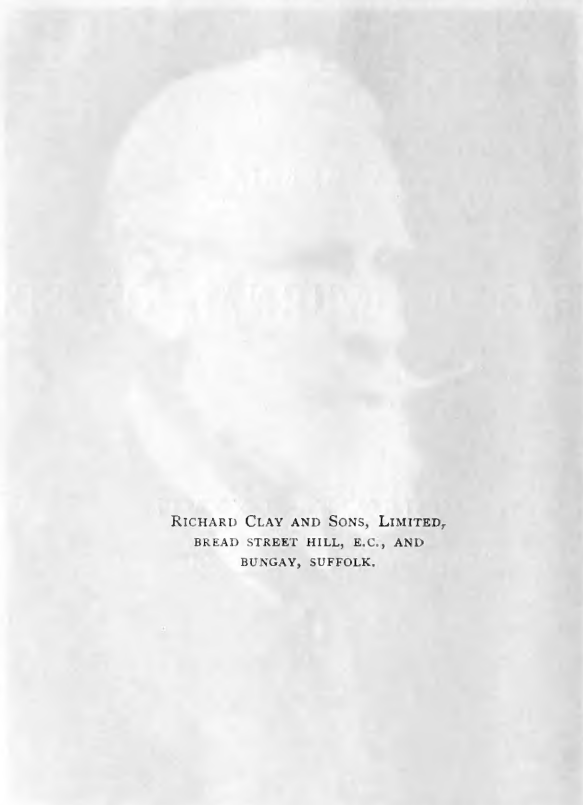

RICHARD CLAY AND SONS, LIMITED,
BREAD STREET HILL, E.C., AND
BUNGAY, SUFFOLK.

William Crookes

1-4-202

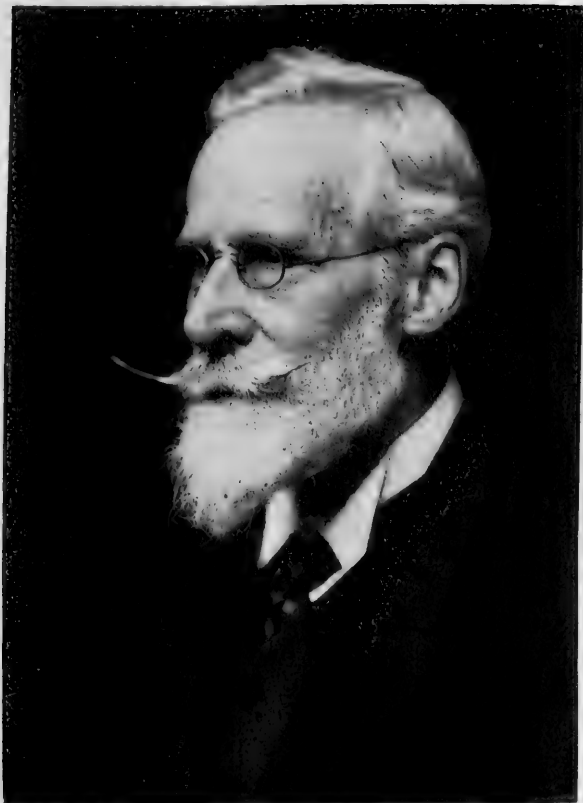

William Brewster.



INDEX.

- AARDKORST, De Vormen der, Inleiding tot de Studie der Physiographic, J. van Baren, 76
- Abel's Laboratory Handbook of Bacteriology, Prof. R. T. Hewlett, 580
- Aberystwyth, New Chemical Laboratories at, 234
- Abraham (Henri), Propagation of Telephone Currents through Subterranean Lines, 167; Conditions of Maximum Yield for Telephonic Apparatus, 215
- Achard (M.), Influence of Feeding on the Course of Experimental Tuberculosis, 95
- Aciers Spéciaux, les, L. Revillon, 317
- Acoustics: Singing Flames and Tubes with Flames of Several Notes, M. Athanasiadis, 167; Propagation of Telephone Currents through Subterranean Lines, Henri Abraham and M. Devaux-Charbonnel, 167; an Early Acoustical Analogue of Michelson's Echelon Grating, Prof. P. Zeeman, 247; on the Impulses of Compound Sound Waves and their Mechanical Transmission through the Ear, Sir Thomas Wrightson, Bart., 289; the Sensitiveness of Many Persons to Small Differences of Pitch, Dr. N. Stücker, 304; High Wires in Concert Halls, &c., 325; Sensibility of the Ear to the Direction of Explosive Sounds, A. Mallock, F.R.S., 332; Photography of the Vibrations of the Voice, M. Marage, 527; Method of Photographing the Vibrations of a Thin India-rubber Membrane acted on by the Human Voice, Dr. M. Marage, 589; School-room Experiment for Showing the Absorption of Energy by an Acoustic Resonator, Prof. Aristide Fiorentino, 567
- "Acquired" Characters, the Inheritance of, Rev. E. C. Spicer, 247, 342; Dr. G. Archdall Reid, 293, 342, 391; Dr. H. Charlton Bastian, F.R.S., 319, 390; A. D. D., 343; J. T. Cunningham, 367
- Actualities scientifics, Max de Nansouty, 437
- Adami (Prof. J. George), Inflammation, an Introduction to the Study of Pathology, 126
- Adams (C. E.), Tabulated Values of Certain Integrals, 462
- Adams (Prof. F. D.), the Laurentian System of Canada, 142
- Adams (J.), Studies in Plant Life, 554
- Adams (Prof. W. S.), Spectroscopic Determination of the Rotation of the Sun, 158; Sun-spot Spectra, 421
- Adda (Lorenzo d'), the Substitution of Cement for Steel in the Armour of Battleships, 543
- Adve (E. H.), Modern Lithology, illustrated and defined for the use of University, Technical, and Civil-Service Students, 125
- Aéronautics: Flight of Pilot Balloons from the Seine, 13; New Aeroplanes, 105; Scientific Balloon Ascents of July 22-27, 136; Results obtained by the Balloon Observations made in the British Isles, July 22-27, 187; Meteorological Observations at the British Kite Stations, Session 1906-7, Miss M. White, T. V. Pring and J. E. Petavel, 188; Possibilities of a Topography of the Air based on Balloon Observations, Capt. C. H. Ley, 188; Histoire de la Navigation aérienne, W. de Fonvielle, 217; Henry Farman and the Deutsch-Ardeacon Prize, 254; H. Farman and his Aeroplane, 493; Franklin's Descriptions of the first Balloon Ascents, Prof. A. L. Rotch, 256; Stability in Flight, A. Mallock, F.R.S., 293; Major B. Baden-Powell, 320; Herbert Chatley, 320; Balloon Ascent of July 25, 1907, M. J. Vincent, 445; Unmanned Balloon Ascents in 1907 at Munich, A. Schmauss, 495; the Lagging of Temperature Changes at Great Heights behind those at the Earth's Surface shown by Records of Sounding Balloons liberated at St. Louis in April and May, 1906, H. H. Clayton, 402; Dr. Alexander Graham Bell's Experiments with his *Cygnét* Man-lifting Kite, 496; Airships Past and Present, together with Chapters on the Use of Balloons in Connection with Meteorology, Photography, and the Carrier Pigeon, A. Hildebrandt, 562; M. Delagrangé's *Aéroplane*, 564; Scientific Kite and Balloon Ascents, September-December, 1907, 542
- Aeroplanes, New, 105
- Aflao (F. G.), Sunshine and Sport in Florida and the West Indies, 128
- Africa: Climate of Eritrea, Captain Tancredi, 88; Labour-saving Appliances in Transvaal Mines, E. J. Way, 114; Notes on some Bushman Crania and Bones from the South African Museum, Cape Town, Dr. F. C. Shrubbsall, 211; "Kimberlite" and the Source of the Diamond in South Africa, Dr. F. H. Hatch, 224; the Sutherland Volcanic Pipes and their Relationship to other Vents in South Africa, A. W. Rogers and A. L. du Toit, 224; the Diamond Pipes and Fissures of South Africa, H. S. Harger, 224; the Occurrence in Kimberlite of Garnet-pyroxene Nodules carrying Diamonds, G. S. Corstorphine, 224; Kimberlite Dykes and Pipes, F. W. Voit, 224; the Origin of Diamonds, F. W. Voit, 224; Geological Survey of the Eastern Portion of Griqualand West, A. L. du Toit, 224; Ueber die südafrikanischen Diamantlagerstätten, A. Macco, 224; Untersuchungen über einige südafrikanische Diamantlagerstätten, R. Beck, 224; Transvaal Mines Department, Report of the Geological Survey for the Year 1906, Dr. F. H. Hatch, 346; Aus Namaland und Kalahari, Prof. Leonhard Schultze, Sir H. H. Johnston, G.C.M.G., 385; Petrology and Physiography of Western Liberia, J. Parkinson, 527; Flora of Natal, J. M. Wood, 565
- Agriculture: Action of Lime on the Available Soil Constituents, F. B. Guthrie and L. Cohen, 23; the Haustorium of the Sandal-wood Tree, C. A. Barber, 40; Work to be Done at the Experiment Stations at Knysna and Robertson, Cape Colony, Dr. Nobbs, 64; Use of Heat for the Treatment of Coffee Plants against the Indian Borer, Louis Boutan, 96; Report of Royal Agricultural Society, 134; Composition of Indian Oil Seeds, Dr. Leather, 136; Pot Culture at Pusa, Dr. Leather, 136; Agricultural Statistics of India, 208; the Barley Disease, "Deaf Ears," Prof. M. C. Potter, 256; South Australian Wheat Yield during the Last Decade, 279; Cyclo-pedia of American Agriculture, 292; Seed and Soil Inoculation for Leguminous Crops, Prof. W. B. Bottomley, 330; (1) Races bovine, France-Etranger, (2) Races chevalines, Prof. Paul Diftloth, 339; the Journal of the South-eastern Agricultural College, Wye, Kent, 345; Experimental Breeding of the Indian Cottons, H. Martin Leake, 360; Influence of Stimulating Compounds on Crops, M. Uchiyama, 376; Forage Crops for Soiling, Silage, Hay, and Pasture, Dr. Edward B. Voorhees, 388; the Lines of Flow of Water in Saturated Soils, especially Peat-mosses, L. F. Richardson, 407; the Food of American Birds, W. L. McAtee, 564; Agricultural Experiments and Reports, 590; Investigation of the Washes for Spraying Fruit Trees, Mr. Pickering, 590; Molasses as Cattle Food, Messrs. Lindsey, Holland and Smith, 590-1; History of the Gooseberry Mildew Order of July, 1907, E. S. Salmon, 591; the "Black Scab" or "Warty Disease" of Potatoes, E. S. Salmon, 591; the Plasmo-para Vine Disease in Algeria, Mr. Lounsbury, 591; the Pine Disease, *Diplodia pinea*, 591; Occurrence of Cyanogenic Glucosides in Feeding Stuffs, T. A. Henry and S. J. M. Auld, 598; Improvement of the Sugar-cane, 614
- Aitken (Dr. John, F.R.S.), the Winding of Rivers, 127
- Aitken (Prof.), Two Hundred New Double Stars, 328; the Moving Object near Jupiter, 497
- Aitken (Thomas), Road-making and Maintenance, 244

- Albrecht (Prof.), the Moving Object near Jupiter, 497
- Alcohol and the Human Body, Sir Victor Horsley, F.R.S., Dr. Mary D. Sturge and Dr. Arthur Newsholme, 386
- Algebra: Easy Exercises in Algebra for Beginners, W. S. Beard, 315; Synopsis of Linear Associative Algebra, J. B. Shaw, 603
- Algal Variables, Observations of, Dr. K. Graff, 497
- Algué (Rev. Father), Rainfall of the Philippine Archipelago, 64; Typhoon at the Caroline Islands, March, 1907, 469
- Alimentation, the Physiology of, Prof. Martin H. Fischer, 26
- Allan (Andrew), Matter and Intellect: a Reconciliation of Science and the Bible, 341
- Allen (Charles C.), Engineering Workshop Practice, 28
- Alliston (Norman), the Case of Existence, 53
- Alteration in the Calendar, Proposed, 489; Dr. D. Mackie, 534; Corr., 541
- Altitude Tables, H. F. Ball, 365
- Amazonicas, Album de Aves, Dr. E. A. Goeldi, 220
- Ameghino (Dr. Florentino), les Formations sédimentaires du Crétacé supérieur et du Tertiaire de Patagonie, avec un Parallèle entre leur Faune mammalogiques et celles de l'Ancien Continent, 68; *Tetraprothomo argentinus* from the later Tertiary Deposits of Monte Hermosa, 113
- America: Dyeing in Germany and America, Sidney H. Higgins, Prof. Walter M. Gardner, 4; Recent Publications of the United States Museum, 91; the Birds of North and Middle America, R. Ridgway, 91; Catalogue of the Type and Figured Specimens of Fossils, Minerals, Rocks and Ores in the Department of Geology, U.S. Mus., J. P. Merrill, 01; Revision of the Pelycosauria of North America, E. C. Case, 186; Archæology in America, H. R. Hall, 186; American Investigations on Electrolytic Conductivity, 213; the Interdependence of Medicine and Other Sciences, Dr. W. H. Welch at Chicago Meeting of American Association, 283; Chicago Meeting of American Association, 302; Sectional Addresses at, 378; Music and Melody, Prof. W. C. Sabine, 378; Heredity and Environic Forces, Dr. MacDougal, 378; the Mechanism in Heredity, Dr. E. G. Conklin, 378; Anthropology of California, Prof. A. L. Kroeber, 379; Tendencies in Pathology, Dr. Simon Flexner, 379; Cyclopedica of American Agriculture, 292; American Ethnology, Dr. J. W. Fewkes, 329; Forage Crops for Soiling, Silage, Hay, and Pasture, Dr. Edward B. Voorhes, 388; the Games of the North American Indians, Stewart Culin, Dr. A. C. Haddon, F.R.S., 568
- Amœba, a Variation in, M. D. Hill, 367
- Anæsthesia, the Induction of, by Chloroform, 226
- Anatomy: the Surgical Anatomy of the Horse, John T. Share-Jones, 170; on the Impulses of Compound Sound Waves and their Mechanical Transmission through the Ear, Sir Thomas Wrightson, Bart., 289; der Einfluss des Klimas auf den Bau der Pflanzengewebe, Anatomisch-physiologische Untersuchungen in den Tropen, Dr. Carl Holttermann, 313; Evolution of Mammalian Molar Teeth, to and from the Triangular Type, H. F. Osborn, 435; Physiologie und Anatomie des Menschen mit ausblicken auf den ganzen Kreis der Wirbeltiere, Dr. Felix Kienitz-Gerloff, 484; Death of Prof. Franz von Leydig, 564
- Ancient British Monuments, Notes on, Sir Norman Lockyer, K.C.B., F.R.S., 56, 82, 159, 249, 368, 414, 487, 536
- Anderson (Dr. Tempest), Report on the Eruptions of the Soufrière in St. Vincent in 1902, the Changes in the Districts, and the Subsequent History of the Volcanoes, 549
- Anderson (Sir Thomas M'Call), Death of, 298
- Andrews (Dr. C. W.), Natural History "Guide-books," the Elephant Group, 613
- Andrews (Prof. E. A.), Young Stages of Fresh-water American Cray-fishes, 87
- Andrews (E. A.), Worms and Tree-Planting, 205
- Andrews (E. C.), Geographical Significance of Floods, with especial Reference to Glacial Action, 192
- Andromeda Nebula, Parallax of the, Dr. Karl Bohlin, 446
- Andromedæ, Provisional Elements for the Spectroscopic Binary, Dr. H. Ludendorff, 182
- Animal Life, Evolution and, David Starr Jordan and Vernon Lyman Kellogg, 242
- Animals, the Diseases of, Nelson S. Mayo, 436
- Anandale (Dr. Thomas), Death of, 178
- Anniversary Meeting of the Royal Society, 107
- Antarctica: National Antarctic Expedition, 1901-4, 33; Magnetic Results obtained by the National Antarctic Expedition of 1901-4, Dr. C. Chree, 453; National Antarctic Expedition, 1901-4, Geology of South Victoria Land, H. T. Ferrar, Petrography, Dr. Prior, Prof. J. W. Gregory, F.R.S., 501; Dr. Jean Charcot's Antarctic Expedition, 204; Scottish National Antarctic Expedition, Report on the Scientific Results of the S.Y. Scotia during the years 1902, 1903, and 1904, under the Leadership of W. S. Bruce, Vol. II., Physics, 618
- Anthropology: Questions on the Customs, Beliefs, and Languages of Savages, Method of Use, Dr. J. G. Frazer, 16; Death and Obituary Notice of Dr. A. M. Pirrie, 62; Brains of Australian Natives, Dr. W. L. H. Duckworth, 64; Teeth of Australians, Dr. Ramsay Smith, 64; Religion of the Indians of California, A. L. Kroeber, 87; Royal Anthropological Institute, 94, 139, 143, 166, 359, 406, 454, 502, 551; Burial Mounds in Japan, Prof. G. G. Gowland, 139; Head of Australian Aborigine, Prof. Cunningham, 139; the Friction Drum, H. Balfour, 139; Excavation of a Barrow at Chapel Carn Brea, Cornwall, H. C. King and B. C. Polkinghorne, 143; Holed Stone at Kerrow, Cornwall, H. C. King and B. C. Polkinghorne, 143; Cist and Urn at Tregiffan Vean, H. C. King and B. C. Polkinghorne, 143; the Romance of Savage Life, describing the Life of Primitive Man, his Customs, Occupations, Language, Beliefs, Arts, Crafts, Adventures, Games, Sports, &c., G. F. Scott Elliot, 171; on the Cranial and Facial Characters of the Neandertal Race, Prof. W. J. Sollas, 262; the Village Deities of Southern India, Dr. Whitehead, 278; Ancient Egypt the Light of the World: a Work of Reclamation and Restitution, Gerald Massey, 291; Primitive Traditional History: the Primitive History and Chronology of India, South-eastern and South-western Asia, Egypt and Europe, and the Colonies thence sent forth, J. F. Hewitt, 291; Death and Obituary Notice of Rev. Dr. Lorimer Fison, 299; the Fossiliferous Deposits of the Bengawan River in Java, Dr. J. J. Elberts, 299; St. George and the Palilia, Dr. J. G. Frazer, 327; Anthropology of California, Prof. A. L. Kroeber, 379; Aus Namaland and Kalahari, Prof. Leonhard Schultz, Sir H. H. Johnston, G.C.M.G., 388; New Instrument for determining the Colour of the Hair, Eyes, and Skin, J. Gray, 406; Death of Dr. A. W. Howitt, C.M.G., 443; Death and Obituary Notice of Sir Denzil Ibbetson, 443; Montenegrin Manners and Customs, Edith Durham, 454; Gods and Godlings, David Patrick, 462; Distribution of Populations of the Earth in Dependence upon Natural Conditions and the Activity of Man, A. I. Voieikoff, 498; Origin of the Crescent as a Mohammedan Badge, Prof. Ridgeway, 502; Sinhalese Magic, Dr. W. L. Hildburgh, 551
- Aphorisms and Reflections, T. H. Huxley, 341
- θ Aquilæ, the Orbit of the Spectroscopic Binary, W. E. Harper, 281
- Arber (E. A. Newell), the Structure of *Sigillaria scutellata*, 549
- Archæology: Notes on Ancient British Monuments, Sir Norman Lockyer, K.C.B., F.R.S., 56, 82, 159, 249, 368, 414, 487, 536; Ancient Dyes for Coinage, Prof. C. Zenghelis, 65; "Grave Stones" from New South Wales, N. W. Thomas, 94; May Gorseeds, Rev. John Griffith, 128; the Annual of the British School at Athens, H. R. Hall, 129; Find of Bronze Weapons, Implements, and Vessels at Khinaman, South-east Persia, Major Sykes, 130; Excavation of a Barrow at Chapel Carn Brea, Cornwall, H. C. King and B. C. Polkinghorne, 143; Holed Stone at Kerrow, Cornwall, H. C. King and B. C. Polkinghorne, 143; Cist and Urn at Tregiffan Vean, H. C. King and B. C. Polkinghorne, 143; Dragonsque Forms on and beneath Founts, G. Le Blanc Smith, 156; British Chariot Burial discovered at Hunmanby, T. Sheppard, 180; Archæology in America, H. R. Hall, 186; Decorative Art of Crete in the Bronze Age, Edith H. Hall, 186; Recent Discoveries of Palæolithic Implements, Sir John Evans, 214; Archæological Remains in Wales and the Marches, 227; Discovery of Group of Dene-holes in Woods between Woolwich and Erith, 230; Neolithic Dewponds and Cattle-ways, Dr. Arthur John Hubbard and George Hubbard, W. E. Rolston, 245; Manx Crosses, or the Inscribed and Sculptured Monuments of the Isle of

Man from about the End of the Fifth to the Beginning of the Thirteenth Century, P. M. C. Kermode, 265; Orientation of the Avebury Circles, Rev. Ed. H. Goddard, 320; Burial Customs of Ancient Egypt, Prof. J. Garstang, H. R. Hall, 439; Megalithic Remains in Central France, A. L. Lewis, 503; Martinmas in May, Rev. C. S. Taylor, 510; Palaeolithic Paintings of Man and Animals in the Portal Cave, René Jeannel, 528; Papers of the British School at Rome, 532; an Early Notice of Neolithic Implements, Prof. John L. Myres, 535; Index of Archaeological Papers, 557; L'Europe préhistorique, Sophus Müller, Dr. William Wright, 578; Ancient Britain and the Invasions of Julius Caesar, Dr. T. Rice Holmes, 601; The Tabernacle: its History and Structure, Rev. W. Shaw Caldecott, *supp.* to March 5, x; Solomon's Temple: its History and Structure, Rev. W. Shaw Caldecott, *supp.* to March 5, x

Architecture, Naval, a Contribution to the History of Iron-clads, Lord Rosse, 356; *see* Naval

Arctic: Death and Obituary Notice of Sir F. L. McClintock, K.C.B., F.R.S., 61; Results obtained by the Ziegler Polar Expedition of 1903-5, J. A. Fleming, 207; Anthony Fiala, Dr. C. Chree, F.R.S., 544; the Arctic Whaling Voyage of Last Year, T. Southwell, 417; Return of Captain Einar Mikkelsen and the Anglo-American Polar Expedition, 541

Aristotelian Society, Proceedings of the, 290

Arithmetic: Arithmetic for Schools, Rev. J. B. Lock and V. M. Turnbul, 27; Arithmetic, chiefly Examples, G. W. Palmer, 27; a Modern Arithmetic, with Graphic and Practical Exercises, H. Sydney Jones, 27; Notes on Indian Mathematics—Arithmetical Notation, R. Kaye, 347; Whittaker's Arithmetic of Electrical Engineering for Technical Students and Engineers, 365

Arloing (S.), Characters of Tubercular Infection in Their Relations with the Diagnosis of Tuberculosis, 503

Armature Construction, H. M. Hobart and A. G. Ellis, 532

Armour of Battleships, the Substitution of Cement for Steel in the, Lorenzo d'Adda, 543

Arndt (Dr. Kurt), Technische Anwendungen der Physikalischen Chemie, 52

Arunta, New Facts about the, M. Freiherr v. Leonhardi, 44

Asia, the Pulse of, a Journey in Central Asia illustrating the Geographic Basis of History, Ellsworth Huntington, Prof. Grenville A. J. Cole, 314

Asiatic Society of Bengal, 168, 359, 455, 504

Association of Economic Biologists, 599

Astrographic Catalogue, the, Prof. Riccio, 158

Astrographic Congress, the President of the, 520

Astronomy: Dr. Edward Sang's Collection of MS. Calculations in Trigonometry and Astronomy, Dr. R. H. Traquair, F.R.S., 13; Our Astronomical Column, 17, 42, 66, 89, 115, 137, 158, 182, 208, 234, 258, 281, 302, 328, 353, 377, 401, 421, 446, 470, 497, 520, 544, 567, 590, 616; Comet Mellish (1907e), 17, 138; M. Borrelly, 17; G. van Biessbroeck, 17; Dr. M. Ebell, 18, 66; P. Chofardet, 23; Ephemeris for Comet 1907e, Dr. Wirz, 281; Observations of, Dr. J. Holetschek, 353; the Transit of Mercury, M. Bigourdan, 18; the Recent Transit of Mercury, MM. Javelle and Simonin, 116; M. Charlois, 116; M. Bourget, 116; M. Borrelly, 116; M. Esmiol, 116; Abbé Th. Moreux, 116; Comte de la Baume Pluvinel, 116; Observations of the Transit of Mercury of November 14, J. Comas Solá, 167; M. Pidoux, 567; M. Gautier, 567; Mercury as a Morning Star, 115; Measurements of the Diameters of Mercury, Robert Jonckheere, 431; Changes on Saturn's Rings, Prof. Campbell, 18; Saturn's Rings, Dr. Ristenpart, 67; Prof. Hartwig, 67; Prof. Lowell, 67, 116, 616; Paul Guthnick, 67; Prof. B. Peter, 90; M. Schaer, 90; Dr. Hassenstein, 90; Rev. T. E. R. Phillips, 234; Dr. Lau, 234; Prof. Barnard, 401; Mr. Lampland, 616; Saturn Apparently without Rings, M. Flammarion, 182; Saturn, a New Ring Suspected, G. Fournier, 302; the Saturn Perturbations of Various Comets, Dr. Johannes Wendt, 568; a Bright Meteor, Arthur Mee, 18; November Meteors, John R. Henry, 31; Occultation of Neptune by the Moon, Dr. Downing, 42; the Improvement of Celestial Photographic Images, Prof. Lowell, 42; the Great Red Spot on Jupiter, Mr. Denning, 42; Photographs of Jupiter, M. Quéniisset, 90; Photographs of

Jupiter's Satellites VI. and VII., 137; Uniformly Distributed Dark Spots on Jupiter, Scriven Bolton, 401; Simultaneous Observations of Jupiter, Jean Mascart, 259; a Possible New Satellite to Jupiter, P. Melotte, 470; Observations of Jupiter during the Present Opposition, P. Vincart, 471; the Moving Object near Jupiter, Prof. Albrecht, 497; Prof. Aitken, 497; the Recently Discovered Satellite of Jupiter, Mr. Melotte, 567; Mutual Occultations and Eclipses of Jupiter's Satellites, Mr. Whittem, 567; the New Eighth Satellite of Jupiter, Astronomer Royal, 575; A. C. D. Crommelin, 575; Red Stars near Nova Velorum, Mrs. Fleming, 42; Prof. Pickering, 42; the Systematic Error of Latitude observed with a Zenith Telescope, Herr Battermann, 42; K. Hirayama, 42; Investigation of Inequalities in the Motion of the Moon produced by the Action of the Planets, Prof. S. Newcomb, assisted by Frank E. Ross, 43; Notes on Ancient British Monuments, Sir Norman Lockyer, K.C.B., F.R.S., 56, 82, 150, 249, 368, 414, 487, 536; a Large Solar Prominence, Dr. A. A. Rambaut, 66; Mars as the Abode of Life, Prof. Lowell, 66, 471; Comparisons of the Places of Mars for the Oppositions of 1907 and 1909, Dr. Downing, 67; Photographs of Mars, Prof. Lowell, 182; Is Mars Habitable? a Critical Examination of Prof. Lowell's Book, "Mars and its Canals," with an Alternative Explanation, Dr. Alfred Russel Wallace, F.R.S., Dr. William J. S. Lockyer, 337; the Possibility of Life in Mars, C. O. Bartrum, 392; Dr. J. W. Evans, 392, 413; Dr. W. Ainslie Hollis, 438; Prof. Percival Lowell, 461; Dr. G. Johnstone Stoney, F.R.S., 461; Water Vapour in the Martian Atmosphere, William E. Rolston, 442; Mr. Slipher, 497; Presence of Water Vapour in the Atmosphere of Mars, Prof. P. Lowell, 503, 606; Elements and Ephemeris for the Minor Planet Patroclus, V. Heinrich, 67; Astronomical Occurrences in December, 89; in January, 208; in February, 302; in March, 421; in April, 520; in May, 616; Final Designations of Recently Discovered Variables, 90; a Large Eruptive Prominence, Mr. Fox, 90; Surveys of Nebulae, P. Gotz, 90; Royal Astronomical Society, 94, 478, 575; Ultra-violet Region in Sun-spot Spectra and Spectrum of Comet d, 1907, J. Evershed, 94; the Permanency of some Photovisual Lenses, Dr. W. J. S. Lockyer, 94; Spectroscopic Observations of Cyanogen in the Solar Atmosphere and in Interplanetary Space, H. F. Newall, 94; the Total Solar Eclipse of January 3, 1908, Dr. W. J. S. Lockyer, 104, 274; the Recent Total Solar Eclipse, 544; a Bright Meteor, T. F. Conolly, 115; Death of Dr. Asaph Hall, 132; Obituary Notice of, 154; Temperature Control of Silvered Mirrors, Dr. Heber D. Curtis, 137; Orbits of Spectroscopic Binaries, Dr. Curtis, 138; Solar Prominences in 1906, Prof. Riccio, 138; Search Ephemeris for Comet 1907a (Giacobini), Prof. Weiss, 138; a Further Observation of Comet 1907a, Prof. Wolf, 158; the Giacobini Comet 1907a, MM. Giacobini and Javelle, 167; Presence of Sulphur in some of the Hotter Stars, Sir Norman Lockyer, K.C.B., F.R.S., 141; the "Day by Day" Tellurian, Messrs. G. Philip and Son, 157; the Maximum of Mira, 1906, Naozo Ichinohe, 158; the Recent Maximum of Mira Ceti, Felix de Roy, 544; Spectroscopic Determination of the Rotation of the Sun, Prof. Adams, 158; Newly Discovered Spectroscopic Binaries, A. B. Turner, 158; the Astrographic Catalogue, Prof. Riccio, 158; Stars having Peculiar Spectra, Mrs. Fleming, 158; Weakened Lines in Sun-spot Spectra, Mr. Nagaraja, 158; Sun-spot Spectra, Prof. W. S. Adams, 421; Charles M. Olmsted, 421; Apparatus designed for Stars Composed Partly of Gas and Partly of Solid Particles, H. Deslandres, 167; Provisional Elements for the Spectroscopic Binary α Andromedæ, Dr. H. Ludendorff, 182; Nova Persei, 1901, Prof. Barnard, 182; the Recent Spectrum and Magnitude of Nova Persei No. 2, Prof. Hartmann, 377; the Moon in Modern Astronomy, Ph. Fauth, W. E. Rolston, 195; Astronomical Essays, Historical and Descriptive, J. Ellard Gore, W. E. Rolston, 195; Evolution of Planets, Edwin G. Camp, W. E. Rolston, 195; Daniel's Comet, 1907d, Herr Kritzinger, 208, 544; Dr. J. Holetschek, 353; Ephemeris for, Herr Kritzinger, 421; Ephemeris for Encke's Comet, M. Kamensky and

- Fr. Korolnikov, 208; Return of Eneke's Comet (1908a), Prof. Wolf, 234; Observation of Eneke's Comet on December 25, 1907, Prof. Wolf, 281; Photographic Observations of Eneke's Comet (1908a), Prof. Wolf, 302; Eneke's Comet, 1908a, M. Kamensky and Mdlle. Korolnikov, 353; Prof. Wolf, 353; Dr. Bäcklund, 547; Dr. Ebell, 547; Absolute Scale of Photographic Magnitudes, J. A. Parkhurst and F. C. Jordan, 208; Annual Astronomical Publications, 208; the Canyon Diablo Meteorites, G. P. Merrill and Wirt Tassin, 208; Death and Obituary Notice of Dr. P. J. C. Janssen, 229; the Spectra of Two Meteors, M. Blakjō, 234; the Constancy of Wave-lengths of Spectral Lines, Prof. Kayser, 234; Death of Lieut.-Colonel R. L. J. Ellery, F.R.S., 254; Obituary Notice of, 208; Comets Due to Return this Year, W. T. Lynn, 258; Determination of the Moon's Light with a Selenium Photometer, J. Stebbins and F. C. Brown, 258, 302; the Appearance of Neptune in Small Telescopes, Mr. Holmes, 258; Mr. Maw, 258; the "Annuaire Astronomique" for 1908, 258; Death of Prof. C. A. Young, 277; Obituary Notice of, 324; a Newly Discovered Bright Minor Planet (1908 B.M.), Dr. Kopff, 281; Measures of Double Stars, C. P. Olivier and R. E. Wilson, 281; Two Hundred New Double Stars, Prof. Atiken, 328; Double-star Observations, Dr. Joel Stebbins, 401; the Absorption of D_3 (Helium) in the Neighborhood of Sun-spots, Father Cortie, 281; the Helium Line, D_3 , as a Dark Line in the Solar Spectrum, A. A. Buss, 377; the Helium, D_3 , Line in the Solar Spectrum, Captain Daunt, 520; the Orbit of the Spectroscopic Binary θ Aquilæ, W. E. Harper, 281; Eclipse Observations, August, 1905, M. Donitch, 281; a Useful Sun and Planet Chart, 302; the Distortion of Photographic Films in Stellar Work, Dr. Frank Schlesinger, 328; a New Astronomical Journal, 328; the Study of Meteor Trails, Prof. Trowbridge, 328; the Accuracy of Double-star Measures, Prof. Doberck, 328; Forty-one New Variable Stars, 329; Death of Rev. F. Howlett, 349; Occultations of Uranus in 1908, Dr. Downing, 353; Planets now Visible, 353; a Catalogue of Zodiacal Stars, H. B. Hedrick, 353; Meteors observed on January 2, P. Muusmann and H. Wanning, 353; the Calorific Solar Radiation, C. Féry and G. Millochau, 359; Altitude Tables, F. Ball, 365; a Detailed Study of the Photosphere, Mr. Chevalier, 378; Astronomischer Jahresbericht, A. Berberich, 389; the Objective Prism in Solar Spectroscopy, E. Schaer, 401; Planetary Photography, Prof. Percival Lowell, 402; zur Geschichte der Astronomischen Messwerkzeuge von Purbach bis Reichenbach 1450 bis 1830, Joh. A. Repsold, 409; the Spectrum of the Aurora Borealis, Dr. W. Marshall Watts, 421; Astronomy in Wales, 421; Micrometer Observations of Phoebe, Prof. Barnard, 421; Death and Obituary Notice of Dr. W. E. Wilson, F.R.S., 443; the Parallax of the Andromeda Nebula, Dr. Karl Böhlín, 446; the Orbit of γ Virginis, Dr. Doberck, 446; the Large Solar Prominence of May 21, 1907, Father Féry, 440; Spanish Observations of the Total Solar Eclipse of August, 1905, 446; a New Variable of the U Geminorum Type, Prof. Hartwig, 446; the Canadian Astronomical Handbook for 1908, 446; "Stonyhurst Sun Discs," Father Cortie, 469; the Variable Star 31, 1907, Aurigæ, Prof. Hartwig, 471; Recent Observations of Venus, J. M. Harg, 471; the System of ζ Ursæ Majoris (Mizar), Prof. Frost, 471; Variation in the Radial Velocity of β Ursæ Majoris, Dr. H. Ludendorff, 520; the Variability of the Nucleus of the Planetary Nebula N.G.C. 7662, E. E. Barnard, 478; Perturbations of Halley's Comet in the Past, the Period 1066-1301, P. H. Cowell and A. C. D. Crommelin, 478; the Meteors of Halley's Comet, W. F. Denning, 610; Peculiarities in the Structure of some Heavenly Bodies, Prof. Suess, 490; the Dispersion of Light in Interstellar Space, Dr. C. Nordmann, 497; Distribution of Standard Time in Egypt, Captain H. G. Lyons, 497; Observations of Algol Variables, Dr. K. Graff, 497; Nebulae and Nebulosity observed by Prof. Barnard, 497; les Progrès de la Photographie astronomique, Prof. P. Stroobant, 508; Prominence and Coronal Structure, Dr. William J. S. Lockyer at Royal Society, 514; Structure of the Corona, Prof. Hansky, 590; Comet 1907 II, Prof. E. Weiss, 520; the President of the Astrophysical Congress, 520; Two Remarkable Spectroscopic Binaries, Mr. Gore, 520; Dr. Nordmann's Variable Star Observations, 520; April Meteors, John R. Henry, 535; Observatory Map of the Moon, Mr. Porthouse, 544; Sun-spot Observations, T. Epstein, 544; Meridian Circle Observations of Parallax Stars, 544; a New Expedition to the Southern Hemisphere, 544; the Hamburg Observatory, Prof. Schorr, 544; Parallax Observations, Dr. Karl Böhlín, 507; Astronomical Photography with Portrait Lenses, Prof. Barnard, 507; the Harvard College Observatory, Prof. Pickering, 507; Spectroscopic Binaries now under Observation, Prof. Frost, 590; Prof. Hartmann, 590; Prof. Pickering, 590; the Relations between the Colours and Periods of Variable Stars, S. Beljawsky, 590; a Field Method of determining Longitudes, E. B. H. Wade, 590; Observations of Eros, G. Van Biesbroeck, 590; Variable Radial Velocity of η Virginis, W. E. Harper, 590; the Children's Book of Stars, G. E. Mitton, 605; a New Star-finder, C. Baker, 610; the Systematic Motions of the Stars, Prof. Dvorny, 616; Determination of the Errors of the Paris Observatory Réseaux, Jules Baillaud, 617; the Herschel's Nebulæ, Madame Dorothea Isaac-Roberts, 617; Horizon and Prime-vertical Curves for Latitudes $+30^\circ$ to $+60^\circ$, H. H. Kritzinger, 617
- Astrophysics: Death of Dr. Janssen, 178
- Athanasiadis (M.), Singing Flames and Tubes with Flames of several Notes, 167
- Athens, the Annual of the British School at, H. R. Hall, 129
- Atlas of the World's Commerce, 506
- Atmosphere, Helium in the, Dr. J. W. Evans, 535
- Atmosphere, the Isothermal Layer of, W. H. Dines, F.R.S., 390, 462, 486; Dr. Charles Chree, F.R.S., 437; C. E. Stromeyer, 485
- Atmospheric Electricity and Fog, Dr. Charles Chree, F.R.S., 343
- Atomic Theory, on the Physical Aspect of the, the Wilde Lecture of Manchester Literary and Philosophical Society, Prof. J. Larmor, Sec.R.S., 450
- Atomic Theory, Mosaic Origin of the, Dr. John Knott, 486
- Atomic Weights, Re-calculation of, H. E. Watson, 7
- Atoms, an Alleged Originator of the Theory of, Dr. J. L. E. Dreyer, 368
- Atoms, Poseidonius on the Originator of the Theory of, Dr. T. J. J. See, 345
- Audiffren (M.), the Audiffren Refrigerator, 215
- Auger (V.), a Colloidal Solution of Arsenic, 23; Action of Amorphous Arsenic on the Alkyl Halides, 95; Preparation of the Cyanides of Methyl and Ethyl, 215
- Auld (S. J. M.), Occurrence of Cyanogenetic Glucosides in Feeding Stuffs, 508
- Aurora Borealis, the Spectrum of the, Dr. W. Marshall Watts, 421
- Auroral Characteristics of Clouds, George C. Simpson, 344
- Ausgleichsrechnung nach der Methode der kleinsten Quadrate, Dr. F. R. Helmert, 52
- Austin (L. W.), Conditions which Influence the Production of Rapid Electrical Oscillations by Means of the Arc, 41
- Austin (P. C.), Attempted Synthesis of $\begin{matrix} \beta-N & -\beta \\ | & \\ \beta-CH & -\beta \end{matrix}$ diaphth-acridine, 238
- Australia: die Fauna Südwest-Australiens, Ergebnisse der Hamburger südwest-australischen Forschungsreise, 1905, Prof. W. Michaelson and Dr. R. Hartmeyer, 51; Nests and Eggs of Birds found Breeding in Australia and Tasmania, A. J. North, 76; Literature relating to the Australian Aborigines, Dr. A. W. Howitt, 80; R. H. Mathews, 81; die Vegetation der Erde, VII., die Pflanzenwelt von West Australien südlich des Wendekreises, Dr. L. Diels, 171; a Guide to the Study of Australian Butterflies, W. J. Rainbow, 411
- Austrian Science, 304
- Avebury Circles, Orientation of the, Rev. Ed. H. Goddard, 320
- Avifauna Italica, Enrico Hillyer Giglioli, 25

- Backlund (Dr.), Encke's Comet, 547
 Bacos (Roger), die Physik, Sebastian Vogl, 268
 Bacot (A.), the Melanic Variety of the "Peppered Moth," 294
 Bacteriology: die Purpurbakterien, Prof. Hans Molisch, Prof. R. T. Hewlett, 53; Experiments on Typhoid Fever Bacilli, Dr. Ravold, 69; Physiological Properties of Tubercle Bacilli which have been Submitted to the Action of Chlorine, MM. Moussu and Goupil, 216; Relations between Lecithin and Tubercle Bacilli and Tuberculin, A. Calmette, L. Massol, and M. Breton, 552; the Bacteriological Examination of Disinfectants, William Partridge, Prof. R. T. Hewlett, 246; Theory of Disinfection, Harriette Chick, 494; Specimens of Luminous Bacteria, J. E. Barnard, 311; Stages in the Life-history of Green Algae, Prof. Dunbar, 350; Abel's Laboratory Handbook of Bacteriology, Prof. R. T. Hewlett, 580
 Baden-Powell (Major B.), Stability in Flight, 320
 Baden-Powell (Lieut.-General R. S. S.), Scouting for Boys, 293
 Bahr (P. H.), Home-life of some Marsh-birds, 393
 Baillaud (Jules), Determination of the Errors of the Paris Observatory Réseaux, 617
 Bairrow (L.), a Micromanometer, 188
 Baker (C.), a New Star-finder, 616
 Baker (H. B. and Mrs.), Gaseous Nitrogen Trioxide, 93
 Baker (Dr. H. F.), Invariants of a Binary Quintic and the Reality of its Roots, 94; an Introduction to the Theory of Multiply-periodic Functions, Supp. to March 5, v
 Baker (Julian L.), Considerations affecting the "Strength" of Wheat Flours, 598
 Baker (R. T.), the Australian Melaleucas and their Essential Oils, 480
 Balance, a Specific Gravity, for Large Rock Specimens, T. H. D. La Touche, 221
 Baldwin-Wiseman (W. R.), Influence of the Thickness of the Pipe Wall on the Rate of Discharge of Water from Minute Orifices Piercing the Pipe, 231
 Balfour (H.), the Friction Drum, 139
 Ball (F.), Altitude Tables, 365
 Ball (Dr. John), a Description of the First or Aswan Cataract of the Nile, 433
 Ball (L. C.), the Norton Goldfield, 257
 Ballistic Experiments from 1864 to 1880, Rev. Francis Bashforth, 30
 Balls (W. Lawrence), the Cotton Plant, 484
 Balston (R. J.), Notes on the Birds of Kent, 511
 Bancels (J. Larquier des), Physical Modifications of Gelatin in Presence of Electrolytes and Non-electrolytes, 384
 Baratta (Prof. Mario), Methods of Construction adopted in Re-building Calabrian Villages destroyed in the Earthquake of September 8, 1905, 468
 Barber (C. A.), the Haustorium of the Sandal-wood Tree, 40
 Barbier (Ph.), New Method for the Hydration of Pinene, 240
 Baren (J. van), de Vormen der Aardkorst, Inleiding tot de Studie der Physiographie, 76
 Barker (J. T.), Complex Copper Glycol Sulphates, 214
 Barker (Prof. T.). Death of, 85
 Barker (T. V.), Relation between Isomorphous Miscibility and Parallel Growths, 143
 Barkhausen (Dr. H.), das Problem der Schwingungserzeugung, 220
 Barkla (Dr. Charles G.), the Nature of Röntgen Rays, 319; Classification of Secondary X-Radiators, 343
 Barnard (Prof.), Nova Persei, 1901, 182; Saturn's Rings, 401; Micrometer Observations of Phoebe, 421; the Variability of the Nucleus of the Planetary Nebula N.G.C. 7662, 478; Nebulae and Nebulosity observed by, 407; Astronomical Photography with Portrait Lenses, 567
 Barnard (J. E.), Specimens of Luminous Bacteria, 311
 Barnes (Prof. H. T.), Formation of Ground-ice, 412
 Barr (G.), Colour-reactions of Organic Acids with Phenols, 100
 Barrow (G.), the High-level Platforms of Bodmin Moor and their Relation to the Deposits of Stream-tin and Wolfram, 502; Metamorphic Minerals in Calcareous Rocks in the Bodmin and Camelford Areas, 574
 Barrowcliff (M.), the Root and Leaves of *Morinda longiflora*, 94
 Barthe (L.), Action of Nascent Hypiodous Acid upon Acids, 432
 Bartlett (Edward), Obituary Notice of, 325
 Bartlett (E.), Notes on the Birds of Kent, 511
 Bartrum (C. O.), the Possibility of Life in Mars, 392
 Basedow (H.), Glacial Beds of Cambrian Age in South Australia, 165
 Bashforth (Rev. Francis), Ballistic Experiments from 1864 to 1880, 30
 Bastian (Dr. H. Charlton, F.R.S.), the Inheritance of "Acquired" Characters, 319, 390
 Bat, the Greater Horseshoe, in Captivity, T. A. Coward, 599
 Bats, the Family and Genera of, G. S. Miller, 91
 Battermann (Herr), the Systematic Error of Latitude observed with a Zenith Telescope, 42
 Battleships, the Substitution of Cement for Steel in the Armour of, Lorenzo d'Adda, 543
 Baubigny (H.), Separation of Chloride and Iodide of Silver, 407
 Bauer (E.), an Isomer of Diphenylcamphomethane, 575
 Bauer (Hugo), a History of Chemistry, 244
 Baxter (Gregory P.), Re-determinations of the Atomic Weight of Lead, 496
 Bay (Isidore), Estimation of Sulphide of Carbon in Benzenes, 311-2; New Method of Estimating Sulphur in Organic Substances, 407; a Case of Ball Lightning, 479; New Method of Estimating Phosphorus in Organic Materials, 600
 Beadle (Clayton), Chapters on Paper-making, 121
 Beard (W. S.), Easy Exercises in Algebra for Beginners, 315
 Beauchamp (P. de), the Phenols as Parthenogenetic Agents, 47
 Beck (Conrad), Photographic Plates prepared by the Lumière Starch-grain Process for Colour Photography, 188
 Beck (R.), Untersuchungen über einige südafrikanische Diamantenergasterstätten, 224
 Becquerel (Jean), Measurement of the Anomalous Dispersion in Crystals at Different Temperatures, 95; Absorption Spectra of Crystals of the Rare Earths in a Magnetic Field at the Temperatures of the Liquefaction and Solidification of Hydrogen, 527
 Beddard (Frank E., F.R.S.), the Fauna of Madagascar, 8; the Oligochæta Fauna of Lake Birket el Qurun and Lake Nyassa, 608
 Beebe (C. W.), the Geographical Variation in Birds, Effects of Climatic Humidity, 444; the Seasonal Colour-change in Birds, 564
 Bee's "Paralysis," A. D. Imms, 62
 Bees, the *Raisonnement collectif* of, Gaston Bonnier, 399
 Bees, Wild, Wasps, and Ants, and other Stinging Insects, Edward Saunders, F.R.S., 220
 Beever (Dr. C. E.), Distribution of Arteries supplying the Human Brain, 187
 Behn (Dr. U.), the Specific Heats of Helium, 257
 Belfast, the New Municipal Technical Institute, 18
 Beljawsky (S.), the Relations between the Colours and Periods of Variable Stars, 590
 Bell (Alexander Graham), the Mechanism of Speech, 483
 Bell's (Dr. Alexander Graham) Experiments with his *Cygnét* Man-lifting Kite, 496
 Bell (Dr. James, C.B., F.R.S.), Death and Obituary Notice of, 539
 Bell (J. M.), Geology of the Parapara Subdivision, New Zealand, 185
 Belloc (G.), Gases occluded in Steels, 215
 Benedict (Francis Gano), the Influence of Inanition on Metabolism, 610
 Bengal, Plagues and Pleasures of Life in, Lieut.-Colonel D. D. Cunningham, 223
 Benham (Prof. W. B.), the Carnivorous Habits of the Kea, 205
 Benoit (René), Recent Determinations of the Volume of the Kilogram of Water, 239
 Berberich (A.), Astronomischer Jahresbericht, 389

- Bergen (J. Y.), Laboratory and Field Manual of Botany, 554
- Berger (E.), Phosphorus Oxybromide, 431
- Bergthell (Cyril), Determination of Indigotin in Indigo-yielding Plants, 118
- Berry (Rev. G. B.), a Lunar "New Jerusalem," 163
- Berthelot (Albert), Prolonged Anæsthesia by Mixtures of Oxygen and Ethyl Chloride, 263
- Bertrand (Gabriel), Method for Estimating Very Small Quantities of Zinc, 119; Action of Tyrosinase on some Substances resembling Tyrosine, 216; Crystallised *d*-Lalite, 455
- Bessey (Prof. E. A.), the Florida Strangling Figs, 517
- Bevan (P. V.), Newton's Rings in Polarised Light, 9
- Bible, Matter and Intellect, a Reconciliation of Science and the, Andrew Allan, 541
- Bidwell (Dr. Sherrford, F.R.S.), the Photo-electric Property of Selenium, 198
- Biesbroeck (G. van), Comet Mellish (1907e), 17; Observations of Eros, 590
- Bigourdan (M.), The Transit of Mercury, 18
- Biltz (Heinrich and Wilhelm), Übungsbeispiele aus der anorganischen Experimentalchemie, 245
- Binarys, Newly Discovered Spectroscopic, A. B. Turner, 158
- Biology: Die Lösung des Problems der Urzeugung (Archigonia, Generatio spontanea), Martin Kuckuck, 29;
- Éléments de Philosophie biologique, Félix le Dantec, 51;
- die Purpurbakterien, Prof. Hans Molisch, Prof. R. T. Hewlett, 53; Regeneration and Transplantation, Prof. E. Korschelt, 99; Organische Zweckmässigkeit, Entwicklung und Vererbung von Standpunkten der Physiologie, Dr. Paul Jensen, 100; Need for Exhibitions devoted to Modern Biological Technique, 205; Hybrids, C. T. Davies, 213; Evolution and Animal Life, David Starr Jordan and Vernon Lyman Kellogg, 242; Evolution of Life, Dr. Percival Lowell, 350; a Variation in *Amoeba*, M. D. Hill, 367; das Kausalitätsprinzip der Biologie, Dr. Friedrich Strecker, 507; Plant Biology, a Text-book of Elementary Botany arranged for Modern Methods of Teaching, Dr. F. Cavers, 554; die Tierwelt des Mikroskops (die Urtiere), Dr. Richard Goldschmidt, 556; das Süswasser-Plankton, Dr. Otto Zacharias, 556; Befruchtung und Vererbung im Pflanzenreich, Prof. K. Giesenhagen, 556; Notions générales de Biologie et de Plasmogénie comparées, Prof. A. L. Herrera, 558; Transvaal Biological Society, 576; die Bestimmung und Vererbung des Geschlechtes, Dr. C. Correns, 580; Association of Economic Biologists, 599; the Oligochaetous Fauna of Lake Birket el Ourun and Lake Nyassa, Frank E. Beddard, F.R.S., 608; Influence of Temperature on Phagocytosis, J. C. G. Ledingham, 623; Marine Biology, Report on the Diatoms of the *Albatross* Voyages in the Pacific Ocean, 1888-1904, Albert Mann, 91; Correlation of Modifications of the Limpet-shell with Environmental Conditions, E. S. Russell, 180; New Pteropod Mollusc, *Paedocione doliformis*, C. H. Danforth, 325; die Plankton of the English Channel, Dr. L. H. Gough, 524
- Biquard (Robert), Researches on the Rare Gases of Thermal Springs, 432
- Birds: How to Tell the Birds from the Flowers: a Manual of Florinithology for Beginners, Prof. R. W. Wood, 7; Bird-life of the Borders, on Moorland and Sea, with Faunal Notes extending over Forty Years, Abel Chapman, 122; the Birds of Kent, William J. Davis, 122; Notes on the Birds of Rutland, C. Reginald Haines, 122; on the Incidence of Daylight as a Determining Factor in Bird-migration, Prof. E. A. Schäfer, F.R.S., 159; the Birds of Yorkshire, T. H. Nelson, W. Eagle Clark, and F. Boyes, 511; Notes on the Birds of Kent, R. J. Balston, Rev. C. W. Shepherd, and E. Bartlett, 511
- Birket el Ourun, the Oligochaetous Fauna of Lake, and Lake Nyassa, Frank E. Beddard, F.R.S., 608
- Black (O. F.), the Quantitative Determination of Arsenic by the Gutzeit Method, 519
- Blaise (E. E.), Syntheses by Means of the Mixed Organometallic Derivatives of Zinc, Ketone Alcohols, 455
- Blakjo (M.), the Spectra of Two Meteors, 234
- Black (G.), Complete Synthesis of β -Campholene Lactone, 288
- Blanc (Dr. G. A.), Problems of Radio-activity, 280
- Blattstellungen, Mathematische und mikroskopisch-anatomische Studien über, Dr. G. van Iterson, jun., 145
- Blind, Publication of Scientific Works in Embossed Type for the, Lord Rayleigh, 204
- Bloxam (W. P.), Analysis of Indigo, 118
- Blumenthal (Richard), Erythrolytic Function of the Spleen in Fishes, 336
- Body, the Care of the, Dr. Francis Cavanagh, 5
- Boeddieker (Dr. O.), "Black Rain" in Ireland on October 8-9, 1907, 445
- Bohlin (Dr. Karl), Parallax of the Andromeda Nebula, 446; Parallax Observations, 567
- Boldau (Dr. C. F.), Immune Sera, 411
- Bolster (Mr.), Potomac River Basin, 68
- Bolton (Scriven), Uniformly Distributed Dark Spots on Jupiter, 401
- Bonn, Some Scientific Centres, XII., the Botanical Institute of the University of, Prof. E. Strasburger, Prof. D. M. Motter, 321
- Bonney (Prof. T. G., F.R.S.), Records of the Geological Survey of India, Part iii., Notes on Certain Glaciers in North-west Kashmir, H. H. Hayden, Part iv., Glaciers in Lahaul, H. Walker and E. H. Pascoe; Glaciers in Kumaon, G. de P. Cotter and J. Caggin Brown, 201; the Diamantiferous Rock of Kimberley, 248; Antigorite and the Val Antigorite, 406; Glaciers of the Canadian Rockies and Selkirks (Smithsonian Expedition of 1904), Dr. William Hittell Sherzer, 463
- Bonnier (Gaston), the *Raisonnement collectif* of Bees, 399
- Books of Science, Forthcoming, 427
- Booth (H. B.), a British Willow-titmouse, 493
- Borchardt (W. P.), Elementary Statics, 315
- Bordas (F.), the Coloration of Crystallised Alumina, 17; Action of Röntgen Rays upon Crystallised Alumina, 95; Action of Radium Bromide on Precious Stone of the Alumina Family, 95; the Formation of Certain Precious Stones of Crystallised Alumina, 263; Detection of Minute Quantities of Helium in Minerals, 527
- Borrelly (M.), Comet Mellish (1907e), 17; the Recent Transit of Mercury, 116
- Boruttau (Prof. H.), Lehrbuch der medizinischen Physik, 604
- Bose (Prof. J. C.), Comparative Electro-physiology, Supp. to March 5, iii
- Bossuet (Robert), the Silicide of Magnesium, 383
- Bosworth (T. O.), Origin and Mode of Deposit of the Upper Keuper Beds of Leicester, 587
- Botany: the Flora of Columbia, Missouri, and Vicinity, F. P. Daniels, 29; the Botany of Walfish Bay, Prof. H. H. W. Pearson, 40; Structure of the Aleurone Grains in Gramineæ, A. Guilliermond, 48; Death and Obituary Notice of Prof. L. M. Underwood, 62; Roots of *Lycopodium pithyoides*, Miss A. G. Stoeke, 64; Distribution and Adaptation of the Vegetation of Texas, Dr. W. L. Bray, 64; Vergleichende Morphologie der Pflanzen, Dr. Jos. Velenovsky, 76; Death and Obituary Notice of James Herbert Veitch, 86; the Production of a Moor, Dr. C. A. Weber, 87; Algal Growth in Ceylon, Dr. F. E. Fritsch, 87; the Root and Leaves of *Morinda longiflora*, M. Barrowcliff and F. Tutin, 94; Rubber Cultivation in the British Empire, Herbert Wright, 99; the Insoluble Constituent of Para Rubber, Dr. D. Spence, 180; India-rubber and its Manufacture, with Chapters on Gutta-percha and Balata, Hubert L. Terry, C. Simmonds, 296; Development of Pollen Grain in *Dacrydium*, Miss M. S. Young, 114; the Genus *Ribes*, Prof. E. de Janczewski, 135; Linnean Society, 142, 190, 334, 406, 476, 527, 598; Origin of the Ditrimerous Floral Whorls of Certain Dicotyledons, Rev. G. Henslow, 142; Abnormal Structures in Leaves, W. C. Worsdell, 142; Mathematische und mikroskopisch-anatomische Studien über Blattstellungen, Dr. G. van Iterson, jun., 145; Influence of the Hygrometric State of the Air on the Preservation of Seeds, E. Demoussy, 168; die Vegetation der Erde, vii., die Pflanzenwelt von West Australien südlich des Wendekreises, Dr. L. Diels, 171; Chemical Examination of West Australian Poison Plants, E. A. Mann and Dr. W. H. Ince, 180; Niam Fat from the Seeds of *Lophira alata*, Dr. J. Lewkowitsch, 189; Influence of Formal on *Funtumia elastica*, Dr. P. Schidrowitz and F. Kaye, 189; New South Wales Linnean Society, 192, 264;

- the Flora of West Lancashire, J. A. Wheldon and A. A. Wilson, 194; a Peroxydiastase in Dried Seeds, M. Brocq-Rousseu and Edmond Gain, 215; Action of a Magnetic Field of High Frequency on Penicillium, Pierre Lesage, 215; the Production of Chlorophyll in the Higher Plants at Different Luminous Intensities, W. Lubimenko, 216; Grafting in Plants containing Hydrocyanic Acid, L. Guignard, 239; Micro-chemical Research Applied to the Study of the Distribution of the Saponines in Plants, R. Combes, 240; the Wild and Cultivated Cotton Plants of the World, a Revision of the Genus *Gossypium*, Sir G. Watt, F. Fletcher, 241; the Cotton Plant, Lieut.-Colonel D. Prain, C.I.E., F.R.S., 318, 485; W. Lawrence Balls, 484; *Euphorbia dendroides*, a Plant which sheds its Leaves in Summer, 255; the New School of Botany, Trinity College, Dublin, 260; on the Colouring Matters of Flowers, Dr. H. C. Sorby, F.R.S., 260; Micro-chemical Examination of Fruits of *Rhus succedanea*, S. Tabata, 279; the Absorption Spectrum of Protochlorophyll, N. A. Monteverde, 279; Coastal Vegetation of the South Island of New Zealand, Dr. L. Cockayne, 279; Report on a Botanical Survey of Kapiti Island, L. Cockayne, Prof. Arthur Dendy, 297; Fertilisation in the Genus *Cypripedium*, Miss L. Pace, 300; Theory with Regard to the Embryo Sac, Dr. O. Porsch, 300; Some Scientific Centres, XII., The Botanical Institute of the University of Bonn, Prof. E. Strasburger, Prof. D. M. Mottier, 321; Stem Disease Caused by *Massaria theicola*, T. Petch, 326; Brassica Crosses, A. W. Sutton, 324; Researches on the Pulp called *Nette* Flour, A. Goris and L. Crété, 336; Vegetation of Disappointment Island, Dr. L. Cockayne, 375; Result of Crossing Round with Wrinkled Peas, with Special Reference to their Starch-grains, A. D. Darbishire, 382; the Silva of Colorado, F. Ramaley, 390; Commercial Philippine Woods, F. W. Foxworthy, 399; the Essence of *Tetranthera polyantha*, var. *citrata*, Eug. Charabot and G. Laloue, 407; Fixation of Zinc by *Sterigmatocystis nigra*, M. Janvillier, 408; Sporangogenesis in the Fern Genus *Nephrodium*, S. Yamanouchi, 418; Nature and Development of Plants, C. C. Curtis, 436; Disease-resisting Sugar-canes, Sir D. Morris, K.C.M.G., 438; Physiology and Morphology of Californian Hepatics, H. B. Humphreys, 445; Stem of the Flax Plant, T. Tammes, 445; *Spongopora Solani*, Brunch, Prof. T. Johnson, 455; Pollination of Flowers in India, I. H. Burkill, 455; the Manufacture of Pulque, 467; Wild Types and Species of the Tuber-bearing Solanums, A. W. Sutton, 476; the Morphology of Stigmata and of its Appendages in Comparison with Recent Lycopodiales, Prof. F. E. Weiss, 477; the Duration of the Peroxydiastases in Seeds, M.M. Brocq-Rousseu and Edmond Gain, 479; the Australian Melaleucas and their Essential Oils, R. T. Baker and H. G. Smith, 480; Mikroskopisches und physiologisches Praktikum der Botanik für Lehrer, G. Müller, 481; Handboek der botanische Micrographie, Dr. J. W. Moll, 481; Grundzüge der Pflanzenkunde, Prof. K. Smalian, 481; Anatomische Physiologie der Pflanzen und der Menschen, Prof. K. Smalian, 481; Death and Obituary Notice of Prof. W. A. Kellerman, 493; Tamarind Seeds as a Nutritious Food during Famine in India, 494; Flora of the Snares and Auckland Islands, Dr. L. Cockayne, 494; New Isomeride of Vanillin in the Root of Chlorocodon, E. Goulding and R. G. Pelly, 502; Volatile Oils of the Leaves of *Ocimum viride*, E. Goulding and R. G. Pelly, 502; the Indo-Malayan Species of *Cedrela*, Prof. C. de Candolle, 517; the Florida Strangling Figs, Prof. E. A. Bessey, 517; Early Stages of Development of the Sporangia and the Sporocarps of Azolla, Miss W. F. Pfeiffer, 517; "Biak" Opium Substitute favoured by the Malays, L. Wray, 517; Bulletin of Miscellaneous Information, Royal Botanic Gardens, Kew, 534; Trees and their Life-histories, Prof. P. Groom, 538; the Flora of the Canadian Rocky Mountains, E. M. Farr, 541; Light-emitting Plants, Dr. C. Müller, 542; Plant Biology, a Text-book of Elementary Botany arranged for Modern Methods of Teaching, Dr. F. Covers, 544; Laboratory and Field Manual of Botany, J. Y. Bergen and B. M. Davis, 554; Studies in Plant Life, J. Adams, 554; Elementary Botany, M. A. Liversidge, 554; Introduction to Elementary Botany, Charlotte L. Laurie, 554; Our Woodlands, Heaths and Hedges, W. S. Coleman, 554; das Werden und Vergehen der Pflanzen, Prof. P. Gisevius, 556; the Sporangium in the Ophioglossaceae, L. L. Burlingame, 565; Growth connected with Natural Injuries to Trees, Dr. H. von Schrenk, 565; Flora of Natal, J. M. Wood, 565; Vegetation on Doi Sutap, Siam, Dr. C. Hosseus, 588; Anatomy of some Sapotaecous Seedlings, Winifred Smith, 508; Occurrence of Cyanogenic Glucosides in Feeding Stuffs, T. A. Henry and S. J. M. Auld, 598; Fertilisation in *Nephrodium mollis*, S. Yamanouchi, 614
- Bottomley (Prof. W. B.), Seed and Soil Inoculation for Leguminous Crops, 330
- Boudouard (O.), the Extraction of the Gases contained in Metals, 215
- Boulenger (G. A., F.R.S.), Zoology of Egypt, the Fishes of the Nile, 10
- Boulud (M.), the Sugar in the Blood Plasma, 47
- Bourget (M.), the Recent Transit of Mercury, 116
- Boutan (Louis), Use of Heat for the Treatment of Coffee Plants against the Indian Borer, 96
- Bouzat (M.), Ammoniacal Cuprous Sulphate, 288
- Bovallius (Dr. Carl), Death and Obituary Notice of, 112
- Bowers (G. M.), Marine Fish-culture in United States, 179
- Bowman (H. L.), the Structure of Perowskite, 358
- Boyes (F.), the Birds of Yorkshire, 511
- Boys (C. V.), a Diabolo Experiment, 188
- Bragg (Prof. W. H.), the Nature of γ and X-Rays, 270, 509
- Braille Type, Publication of Scientific Works in Embossed Type for the Blind, Lord Rayleigh, 204
- Bray (Dr. W. L.), Distribution and Adaptation of the Vegetation of Texas, 64
- Breton (M.), Relations Between Lecithin and Tubercle Bacilli and Tuberculin, 552
- Brickwork: I laterizi, G. Revere, 508
- Briggs (R. V.), Determination of Indigotin in Indigo-yielding Plants, 118
- Brightmore (Dr. A. W.), Stresses in Masonry Dams, at Institution of Civil Engineers, 303
- Brillouin (Marcel), Leçons sur la Viscosité des Liquides et des Gaz, 341
- Briner (E.), Formation of Ozone by the Action of the Silent Discharge at Low Temperatures, 215
- Britain, Ancient, and the Invasions of Julius Cæsar, Dr. T. Rice Holmes, 601
- British Association Seismology, Prof. John Milne, F.R.S., 198
- British Association, the Forthcoming Dublin Meeting of the, 608
- British Empire, Rubber Cultivation in the, Herbert Wright, 99
- British Isles, the Moths of the, Richard South, 483
- British Journal Photographic Almanac and Photographer's Daily Companion for 1908, the, 172
- British Monuments, Notes on Ancient, Sir Norman Lockyer, K.C.B., F.R.S., 50, 82, 150, 249, 368, 414, 487, 536
- British Pharmaceutical Conference at Manchester, Immunity to Disease among Plants, Prof. F. E. Weiss, 20
- British School at Athens, the Annual of the, H. R. Hall, 129
- British School at Rome, Papers of the, 532
- British Science Guild, the, 274
- Broca (André), Visibility of Night Signals at Sea, 95
- Brocq-Rousseu (M.), a Peroxydiastase in Dried Seeds, 215; the Duration of the Peroxydiastases in Seeds, 479
- Brogie (M. de), Gases Arising from Electric Sparks, 527
- Browett (C.), the Formation of "Snow Rollers" at Ryton, on Dunsmore, January 29-30, 1907
- Brown (Prof. E.), an Experimental Study of Stresses in Masonry Dams, Karl Pearson, F.R.S., A. F. Campbell Pollard, C. W. Wheen, and L. F. Richardson, 209; a Point in the Mathematical Theory of Elasticity, 221
- Brown (F. C.), Determination of the Moon's Light with a Selenium Photometer, 258, 302
- Brown (J. Caggin), Glaciers in Kumaon, 201
- Brown (M. Walton), Death of, 111
- Brown (T. C.), the Primary Hexamer Character of Rugose Corals, *Streptelasma rectum*, 117
- Browne (Frank Balfour), the North Sea Fisheries Investi-

- gations, 523; the Sea-shore Shown to the Children, Janet Harvey Kelman, 533
- Bruce (Mr.), the Tuberculin Test for Cattle, 213
- Bruce (W. S.), Scottish National Antarctic Expedition, Report on the Scientific Results of the S.Y. *Scotia* during the Years 1902, 1903, and 1904, under the Leadership of, vol. ii., Physics, 618
- Bruneau (P.), Crystallised *d*-Talcite, 455
- Brunner (Dr. Karl), Lehrbuch der Chemie und Mineralogie für vierte Klasse der Realschulen, 484
- Bryan (Prof. G. H., F.R.S.), the Forthcoming Mathematical Congress at Rome, 464; Certain Dynamical Analogues of Temperature Equilibrium, 503; the International Mathematical Congress at Rome, 582
- Bryant (F. B.), Fire Conservancy in Teak Forests, 419
- Buchanan (J. Y., F.R.S.), the Winding of Rivers, 100
- Buckman (S. S.), Brachiopod Homœomorphy, *Spirifer glaber*, 190
- Building: Weathering Phenomena in Building Stones, E. Kaiser, 181; What Rome was Built with, a Description of the Stones employed in Ancient Times for its Building and Decoration, Mary Winearls Porter, 196
- Building as an Engineering Work in New York, 301
- Buisson (H.), Presence of Spark Lines in the Arc Spectrum, 570
- Bungay, Small Flint Implements from, W. A. Dutt, 102
- Bunge (Dr. G. v.), Text-book of Organic Chemistry for Medical Students, 146
- Burgess (G. H.), Melting Points of the Elements of the Iron group, 65
- Burial Customs of Ancient Egypt, Prof. J. Garstang, H. R. Hall, 439
- Burkitt (T. H.), Pollination of Flowers in India, 455
- Burlingame (L. L.), the Sporangium in the Ophioglossaceæ, 565
- Burrows (C. W.), Best Method for Demagnetising Iron in Magnetic Testing, 401
- Burstall (Prof. F. W.), Experiments on Premier Company's Gas-engine, 326
- Burton (F. M.), the Shaping of Lindsey by the Trent, 371
- Bury (H.), Notes on the River Wey, 454
- Buss (A. A.), the Helium Line, D₃, as a Dark Line in the Solar Spectrum, 377
- Butterflies, a Guide to the Study of Australian, W. J. Rainbow, 411
- Caillé (H.), Formation of Mixtures of Isomers of Constant Melting Point in the Friedel and Crafts Reaction, 576
- Cain (Dr. J. C.), the Chemistry of the Diazo-compounds, 558
- Calculus, a First Course in the Differential and Integral, Dr. W. F. Osgood, 577
- Calcutta: Asiatic Society of Bengal, 168, 359, 455, 504; Jubilee of the Calcutta University, 584
- Caldecott (Rev. W. Shaw), the Tabernacle, its History and Structure, Supp. to March 5, x; Solomon's Temple, its History and Structure, Supp. to March 5, x
- Caldерwood (W. L.), the Life of the Salmon, with Reference more especially to the Fish in Scotland, 173
- Calendar, Proposed Alteration in the, 489; Dr. D. Mackie, 534; Corr., 541
- California, Anthropology of, Prof. A. L. Kroeber, 370
- California and the Californians, (2) the Alps of King-Kern Divide, President D. S. Jordan, 437
- Californian Earthquake of 1906, the, 251
- Callendar (Prof., F.R.S.), Measurement of Temperatures in the Cylinder of a Gas Engine, 141
- Calmette (A.), Relations between Lecithin and Tubercle Bacilli and Tuberculin, 552
- Calorimeter for Gases and Liquids, Simple, Charles Féry, 182
- Cambridge Philosophical Society, 167, 190, 454, 478, 503
- Camden (Lieut. B. H.), Disappearance of McCulloch Peak, Bogosilof Island, 86
- Cameron (Alex.), Lithium in Active Minerals, 455
- Cameron (W. E.), the Annan River Tinfeld, 257
- Camp (Edwin G.), Evolution of Planets, 105
- Campbell (A.), the Use of Variable Mutual Inductances, 71
- Campbell (J. E.), Application of Quaternions to the Problems of the Infinitesimal Deformation of a Surface, 95
- Campbell (N. P.), Preparation of Conductivity Water, 431; Solubility of Iodine in Water, 502
- Campbell (Norman R.), the Theory of Dispersion and Spectrum Series, 607
- Campbell (Prof.), Changes on Saturn's Rings, 18
- Campbell (W. D.), Phosphatic Deposits near Dandaraga, 88
- Camus (Lucien), Ethyl Chloride in the Blood during Anæsthesia, 240
- Canada: Tidal Investigations in Canada, W. Bell Dawson, 202; Geological Survey of Canada, 340; the Canadian Astronomical Handbook for 1908, 436; Glaciers of the Canadian Rockies and Selkirks (Smithsonian Expedition of 1904), Dr. William Hittell Sherzer, Prof. T. G. Bonney, F.R.S., 463
- Candolle (Prof. C. de), the Indo-Malayan Species of *Cedrela*, 517
- Canterbury Puzzles, the, and other Curious Problems, H. E. Dudeney, 341
- Canyon Diablo Meteorites, the, G. P. Merrill and Wirt Tassin, 208
- Carbon Compounds, a Scheme for the Detection of the more Common Classes of, F. E. Western, 74
- Care of the Body, the, Dr. Francis Cavanagh, 5
- Carnegie (Douglas), "Magic Mirror" Effects, 55
- Carnegie Institution, the, 471
- Carteret (G.), Simple Reaction producing a Disinfectant Gas, 600
- Cartesian Plane Geometry, Charlotte A. Scott, 315
- Carus-Wilson (C. A.), the Predetermination of Train-resistance, 156
- Carus-Wilson (Cecil), Musical Sands, 222, 271
- Carver (Prof. T. N.), Suggestion for a New Economic Arithmetic, 496
- Case (E. C.), Revision of the Pelycosauria of North America, 186
- Cathiard (André), Use of Flames as Valves for Alternating High-tension Currents, 263
- Cattle: the Tuberculin Test for Cattle, Mr. Bruce, 213; Mr. Thornton, 213; Races bovines, France-Etranger, Prof. Paul Diffloth, 339
- Cavanagh (Dr. Francis), the Care of the Body, 5
- Cavers (Dr. F.), Plant Biology, a Text-book of Elementary Botany arranged for Modern Methods of Teaching, 554
- Celluloid Area Scale, the White and Bean, Casella and Co., 233
- Ceylon, *Rhynchobdella aculeata* in, Dr. Arthur Willey, F.R.S., 345
- Chapman (Abel), Bird-life of the Borders, on Moorland and Sea, with Faunal Notes extending over Forty Years, 122
- Chapman (F.), Tertiary Limestones and Foraminiferal Tufts of Malekula, New Hebrides, 102
- Charabot (Eug.), the Essence of *Tetranthera polyantha*, var. *citrata*, 407
- Charcot's (Dr. Jean) Antarctic Expedition, 204
- Charlois (M.), the Recent Transit of Mercury, 116
- Charpy (Georges), the Solubility of Graphite in Iron, 215
- Chatley (Herbert), Stability in Flight, 320
- Chattaway (Dr. F. D., F.R.S.), Oxidation of Aromatic Hydrazines by Metallic Oxides, Permanganates, and Chromates, 335; a Method of Depositing Copper upon Glass from Aqueous Solutions in a Thin Brilliantly Reflecting Film, and thus producing a Copper Mirror, Address at Royal Society, 380; Quantitative Conversion of Aromatic Hydrazines into Diazonium Salts, 551
- Chaumat (Henri), the Electrolytic Reduction of Indigo, 239
- Chauveau (A.), Perception of Relief and of Depth in the Simple Image of Ordinary Photographs, 576
- Chemistry: Scientific Worthies, Sir William Crookes, F.R.S., Prof. P. Zeeman, 1; Dyeing in Germany and America, Sidney H. Higgins, Prof. Walter M. Gardner, 4; Re-calculation of Atomic Weights, H. E. Watson, 7; the Coloration of Crystallised Alumina, F. Bordas, 17; some Iodomercurates, A. Duboin, 23; a Colloidal Solution of Arsenic, V. Auger, 23; Formation of Liquid Crystals of Two New Compounds of Cholesterin, Paul Gaubert, 23; Handbuch der anorganischen Chemie, 25; the Victoria Jubilee Technical Institute, Bombay, Dr.

Morris W. Travers, F.R.S., 31; the Production of Natural and Synthetic Indigo, R. J. Friswell, 39; Determination of Indigotin in Indigo-yielding Plants, Cyril Bergthell and R. V. Briggs, 118; Analysis of Indigo, R. Gaunt, F. Thomas, and W. P. Bloxam, 118; Electrolytic Reduction of Indigo, Henri Chaumet, 239; Chemical Society, 47, 93, 143, 166, 238, 334, 383, 431, 502, 551; Constitution of Phenol- and Quinol-phthalene Salts, A. G. Green and P. E. King, 47; Ketene, N. T. M. Wilsmore, 47; Condensation of Acetaldehyde and its Relation to the Biochemical Synthesis of Fatty Acids, H. S. Raper, 47; Electrolysis of Salt Solutions in Liquefied Sulphur Dioxide, Dr. Bertram D. Steele, 47; Action of Aluminium Powder on Silica and Boric Anhydride, F. E. Weston and H. Russell Ellis, 47; Reduction of Metallic Oxides with Calcium Hydride and Calcium, Dr. F. M. Perkin and L. Pratt, 47; the Phenols as Parthenogenetic Agents, Yves Delage and P. de Beauchamp, 47; a New Element, Lutecium, G. Urbain, 48; Lutecium and Neoytterbium, G. Urbain, 432; the Chemistry of Commerce, Robert Kennedy Duncan, 49; Experimental and Theoretical Applications of Thermodynamics to Chemistry, Dr. Walther Nernst, 52; Technische Anwendungen der physikalischen Chemie, Dr. Kurt Arndt, 52; die Ausbreichungsrechnung nach der Methode der kleinsten Quadrate, F. R. Helmert, 52; Re-determination of the Atomic Weight of Radium, Madame Curie, 65; Production and Origin of Radium, Prof. E. Rutherford, 191; Radium Content of Deep-sea Sediments, Prof. J. Joly, 455; Coloration of Glass and Quartz by Radium, Charles E. S. Phillips, 535; Melting Points of the Elements of the Iron Group, G. H. Burgess, 65; the Complete School Chemistry, F. M. Oldham, 74; Practical Chemistry for Army and Matriculation Candidates, Geoffrey Martin, 74; Systematic Practical Organic Chemistry, G. M. Norman, 74; a Course of Practical Organic Chemistry, T. Slater Price and D. F. Twiss, 74; a Scheme for the Detection of the more Common Classes of Carbon Compounds, F. E. Weston, 74; Phosphatic Deposits near Dandaraga, W. D. Campbell, 88; Gaseous Nitrogen Trioxide, H. B. Baker and Mrs. Baker, 93; Diethylauric Bromide, W. J. Pope and C. S. Gibson, 94; Interaction of Methylene Chloride and the Sodium Derivative of Ethyl Malonate, F. Tutin, 94; the Root and Leaves of *Morinda longiflora*, M. Barrowcliff and F. Tutin, 94; the Melting Point of *d*-Phenylglucosazone, F. Tutin, 94; the Diastatic Function of Colloids, J. Duclaux, 95; Action of Gold on the Dioxide of Sodium and Barium, Fernand Meyer, 95; Preparation of Iodides *in vacuo*, Marcel Guichard, 95; Action of Amorphous Arsenic on the Alkyl Halides, V. Auger, 95; *p*-Methoxycinnamic Aldehyde in Essence of Estragon, Maurice Daufreme, 96; Artificial Reproduction of Heavy Spar, Celestine, and Anglesite, Paul Gaubert, 96; Liquid and Gaseous Fuels and the Part they play in Modern Power Production, Prof. V. B. Lewes, 98; Peat Utilisation, 114; Society of Chemical Industry, 118, 189, 263, 382; Influence of the Reaction of the Medium on the Size of the Colloidal Granules, André Mayer, G. Schaeffer, and E. Terroine, 119; Tetraiodide of Uranium, Marcel Guichard, 119; Method for Estimating very Small Quantities of Zinc, Gabriel Bertrand and Maurice Javillier, 119; the Nitrous Isomerisation of Isobutyl Alcohol, Louis Henry, 119; an Alkaloid from Mistletoe, M. Leprieux, 120; Chemical Apparatus made from Transparent Vitreous Silica, 137; Association of Helium and Thorium in Minerals, Hon. R. J. Strutt, F.R.S., 141; the Solidification of Helium, Prof. Alfred W. Porter, 437; Helium Solidified, Prof. Kamerlingh Onnes, 442; the Condensation of Helium, Prof. H. Kamerlingh Onnes, 559, 581; Dr. Morris W. Travers, F.R.S., 606; Helium in the Atmosphere, Dr. J. W. Evans, 535; Emulsions, S. Pickering, 143; Action of Carbonyl Chloride as an Agent for Arresting Isomeric Change, T. M. Lowry and E. H. Magson, 143; Interaction of Metallic Sulphates and Caustic Alkalis, S. Pickering, 143; Chemistry of Bordeaux Mixture, S. Pickering, 143; Interaction in Solution of Ferrous Sulphate and Copper Sulphate, H. R. Ellis and W. H. Collier, 144; Text-book of Organic Chemistry for Medical Students, Dr. G. v. Bunge, 146; Chemistry of

the Silver Voltmeter, F. E. Smith and Dr. T. M. Lowry, 165; Relation between Unsaturation and Optical Activity, T. P. Hilditch, 166; Replacement of Alkyl Radicles by Methyl in Substituted Ammonium Compounds, H. O. Jones and J. R. Hill, 166; Synthesis of Braziliac Acid, W. H. Perkin and R. Robinson, 166; Refractive Power of Diphenylhexatriene and Allied Hydrocarbons, Miss I. Smedley, 166; Affinity Constants of Cases determined by the Agency of Methyl Orange, V. H. Veley, 166; the Constituents of Essential Oil of Nutmeg, F. B. Power and A. H. Solway, 166; Resolution of *sec*-Octyl Alcohol, R. H. Pickard and J. Kenyon, 166; Action of an Incandescent Electric Conductor on the Gases which Surround it, M. Couriot and Jean Meunier, 167; the Lithium contained in Radio-active Minerals, Mlle. Gleditsch, 167; Lithium in Radio-active Minerals, Sir W. Ramsay, K.C.B., F.R.S., 412; Lithium in Active Minerals, Sir William Ramsay and Alex. Cameron, 455; Direct Hydrogenation of some Aromatic Diones, Paul Sabatier and A. Mailhe, 167; Carbon Monoxide in Coal Gas, Léo Vignon, 168; the Insoluble Constituent of Para Rubber, Dr. D. Spence, 180; India-rubber and its Manufacture, with Chapters on Gutta Percha and Balata, Hubert L. Terry, C. Simmonds, 206; Chemical Examination of West Australian Poison Plants, E. A. Mann and Dr. W. H. Ince, 180; Influence of Formal on *Fantonia elastica*, Dr. P. Schidrowitz and F. Kaye, 189; Colour-reactions of Organic Acids with Phenols, Dr. Fenton and G. Barr, 190; Action of Metallic Magnesium on Aliphatic Acids and the Detection of Formic Acid, Dr. Fenton and H. A. Sisson, 190; Decomposition and Nitrication of Sewage (1) in Alkaline Solution, (2) in Distilled Water, J. E. Purvis and R. M. Courtauld, 190-1; Influence of Light and of Copper on Fermentation, J. E. Purvis and W. A. R. Wilks, 191; Platinocyanides, L. A. Levy, 191; Derivatives of Xylose, H. Ryan and G. Ebrill, 191; Radio-activity of Sea-water, J. Joly, 191; Solandrine, New Midriatic Alkaloid, Dr. J. M. Petrie, 192; Nature's Hygiene and Sanitary Chemistry, C. T. Kingzett, 196; the Electrical Conductivity of Aqueous Solutions, Arthur A. Noyes, 213; Conductivity and Viscosity in Mixed Solvents, Harry C. Jones, 213; Complex Copper Glycol Sulphates, J. T. Barker, 214; the Discovery of the Alkali Metals by Davy, Dr. F. Mollwo Perkin, 214; the Centenary of Davy's Discovery of the Metals of the Alkalis, Prof. T. E. Thorpe, C.B., F.R.S., at Royal Institution, 305; Attempt at proving Certain Relations between the Atomic Weights of the Elements, M. Delauney, 215; Gases occluded in Steels, G. Belloc, 215; the Extraction of the Gases contained in Metals, O. Boudouard, 215; Action of Nitrous Acid on Allylamine, Louis Henry, 215; Qualitative Examination of Ciders for Tartaric Acid, G. A. Le Roy, 215; Preparation of the Cyanides of Methyl and Ethyl, M. Auger, 215; a Peroxydiastase in Dried Seeds, M. Brocq-Rousseau and Edmond Gain, 215; Phosphorescence at Low Temperatures, Joseph de Kowalski, 215; Formation of Ozone by the Action of the Silent Discharge at Low Temperatures, E. Briner and E. Durand, 215; the Solubility of Graphite in Iron, Georges Charpy, 215; the Detection and Estimation of Nickel, Emm. Pozzi-Escot, 216; Iso-sparteine, Charles Moreux and Amand Valeur, 216; Action of Tyrosinase on some Substances resembling Tyrosine, Gabriel Bertrand, 216; New Chemical Laboratories at Aberystwyth, 234; Attempted Synthesis



of —CH— —Dinaphthaeridine, A. Senier and P. C.



Austin, 238; Cobaltamine Compounds, C. E. Groves, 239; the Direct Interaction of Aryl Halides and Magnesium, J. F. Spencer and E. M. Stokes, 239; Derivatives of Tetramethyl Glucose, J. C. Irvine and A. M. Moodie, 239; Grafting in Plants containing Hydrocyanic Acid, L. Guignard, 239; the Characterisation of Mercerised Cotton, J. Hubner, 239; Action of Metallic Calcium on Alcohols, F. M. Perkin and L. Pratt, 239; Calorimetric Method for the Determination of Iron in Copper Alloys, A. W. Gregory, 239; New Method for the Hydration of Pinene, Ph. Barbier and V. Grignard, 240; Microchemical Research applied to the Study of

the Distribution of the Saponines in Plants, R. Combes, 240; a History of Chemistry, Hugo Bauer, 244; Ubungsbeispiele aus der anorganischen Experimentalmchemie, Heinrich Biltz und Wilhelm Biltz, 245; the Keeping Power of Fehling's Solution, Dr. Francis Watts and H. A. Tempary, 263; Determinations of Small Quantities of Bismuth, H. W. Rowell, 263; Mechanism of the Transposition of the Phenyl Group in the Iodo-hydrins and Aromatic Glycols, Marc Tiffeneau, 263; Method for Estimation of Iron, Alumina, and Phosphoric Acid, Dr. T. Cooksey, 263; the Formation of Formaldehyde in Solutions of Cane Sugar, A. A. Ramsay, 263; Van Nostrand's Chemical Annual, 1907, 267; the Density of Graphite, H. Le Chatelier and S. Wologdine, 287; the Transformations of Solutions of White Phosphorus into Red Phosphorus, Albert Colson, 287; Constitution of Cast Irons containing Manganese, L. Guillet, 288; Ammoniacal Cuprous Sulphate, M. Bouzat, 288; Complete Synthesis of β -Campholene Lactone, G. Blanc, 288; Phenomena occurring when Soda is Causticised by Means of Lime, Prof. Rudolph Wegscheider and Dr. Heinrich Walter, 304; Influence exercised by a Small Proportion of Water on the Rate of Formation of Ethyl Chloride, A. Kailan, 304; Catalytic Power of Silica and Alumina, J. B. Senderens, 311; Compounds of Terbium and Dysprosium, G. Urban and G. Jantsch, 311; Estimation of Sulphide of Carbon in Benzenes, Isidore Bay, 311-2; the Allotropic Forms of Sulphur, Prof. Walther Spring, 327; New Method of Estimating Sulphur in Organic Substances, Isidore Bay, 407; the Origin of Stereochemistry, Prof. E. Paternò, 328; Results of the Interaction of Mercury with Alloys of other Metals, Dr. J. W. Mallet, F.R.S., 333; Colour and Constitution of Azo-compounds, part ii., the Salts of β -Hydroxy-azo-compounds with Mineral Acids, J. J. Fox and J. T. Hewitt, 334; Action of Diazomethane on the Two Modifications of Isonitrosocamphor, M. O. Forster and H. Holmes, 335; Oxidation of Aromatic Hydrazines by Metallic Oxides, Permanganates, and Chromates, F. D. Chattaway, 335; the Mechanism of Alcoholic Fermentation, A. Slator, 335; the Sulphonation of Benzylethylpropylsilyl Oxide and of Benzylethylpropylsilylamine, H. Marsden and F. S. Kipping, 335; Use of Pyridine Bases as Hydrogen Carriers, W. E. Cross and J. B. Cohen, 335; Abnormal Mobility of the Ions of some Rare Earths, Jules Roux, 335; Researches on the Pulp called Nette Flour, A. Goris and L. Créte, 336; Medico-physical Works of John Mayow (1674), 339; Death and Obituary Notice of R. J. Friswell, 349; the So-called Amorphous Antimony and Bismuth, Prof. Cohen and J. Olie, 352; Heat of Formation of the Anhydrous Oxides of Strontium and Barium, M. de Forcrand, 359; Complex Salts of Iron in which the Iron is Masked, P. Pascal, 359; Order of Addition of Ammonia to Organic α -Oxides of Asymmetrical Structure, H. Krassousky, 359; the Formation of Acetylene from Elementary Substances, Prof. E. Knecht, 359; New Reactions for the Characterisation of Merceric Cotton, J. Hübner, 359; Direct Combination of Carbon and Hydrogen, H. F. Coward, 359; the Atomic Weight of Chlorine, Dr. E. C. Edgar, 359; Organic Chemistry for Advanced Students, Prof. J. B. Cohen, 363; Inorganic Chemistry, E. J. Lewis, 364; the Smoke from Metallurgical Works, W. D. Harkins and R. E. Swain, 376; a Method of depositing Copper upon Glass from Aqueous Solutions in a thin brilliantly reflecting film, and thus producing a Copper Mirror, Dr. F. D. Chattaway, F.R.S., at Royal Society, 380; the Metallic Picrates, O. Silberrad and H. A. Phillips, 383; Colour and Constitution of Azomethine Compounds, F. G. Pope, 383; Residual Affinity of the Coumarins and Thiocoumarins, A. Clayton, 383; Influence of Foreign Substances on Certain Transition Temperatures and the Determination of Molecular Weights, H. M. Dawson and C. G. Jackson, 383; Decomposition of Ammonium Dichromate by Heat, W. M. Hooton, 383; Malacene, a Silicate of Zirconium, A. C. Cumming, 383; Reducibility of Magnesium Oxide by Carbon, R. E. Slade, 383; Crystal Form of Halogen Derivatives of Open Chain Hydrocarbons with Reference to the Barlow-Pope

Theory of Structure, E. M. Jaeger, 383; a β -Lactonic Acid from Acetone and Malonic Acid, A. N. Meldrum, 383; Alcoholysis of Linseed Oil, A. Haller, 383; the Silicide of Magnesium, Paul Lebeau and Robert Bossuet, 383; Colloidal Properties of Starch and a Perfect Solution of this Substance, E. Fouard, 383; Pure Starch, Amylose, L. Maquenne, 407; Physical Modifications of Gelatin in Presence of Electrolytes and Non-electrolytes, J. Largaier des Bancelles, 384; Preparation of Dithymol, H. Cousin and H. Hérissé, 384; γ -Oxytetrolic Acid, MM. Lespiau and Viguier, 384; a Method of Preparing the Cyclic Aldehydes, M. Savarian, 384; Action of Alcohols upon Sodium Benzylate, Marcel Guerbet, 384; Alcohol and the Human Body, Sir Victor Horsley, F.R.S., and Dr. Mary D. Sturge and Dr. Arthur Newsholme, 387; Lehrbuch der theoretischen Elektrochemie auf thermodynamischer Grundlage, J. J. van Laar, 389; Reducing Properties of Organo-metallic Compounds, M. Letellier, 407; the Essence of *Tetranthera polyantha*, var. *citrata*, Eug. Charabot and G. Laloue, 407; Separation of Chloride and Iodide of Silver, H. Baubigny, 407; Atomic Weights of Nitrogen, Oxygen, and Carbon, A. Leduc, 431; Phosphorus Oxybromide, E. Berger, 431; Organic Derivatives of Silicon, Part iv., the Optically Active Sulphobenzylethylpropylsilyl Oxides, F. S. Kipping, 431; Preparation of Conductivity Water, H. Hartley, N. P. Campbell, and R. H. Poole, 431; Diazo-reaction in the Diphenyl Series, G. T. Morgan and Miss F. M. G. Micklethwait, 431; the Triazo-group, Part ii., Azoimides of Propionic Ester and of Methyl Ethyl Ketone, M. O. Forster and H. E. Fierz, 431; Synthesis of Anhydrobraziliac Acid, W. H. Perkin, jun., and R. Robinson, 431; an Isomeric Modification of Hydrated Hypovanadic Acid, Gustave Gain, 432; Action of Nascent Hypoiodous Acid upon Acids, L. Barthe, 432; Researches on the Rare Gases of Thermal Springs, Charles Moureu and Robert Biquard, 432; das Lachgas: eine chemisch-historische Studie, Prof. Ernst Cohen, 434; Traité de Chimie analytique qualitative, suivi de Tables systématiques pour l'Analyse minérale, Louis Duparc and Alfred Monnier, 437; Hydrolysis as Illustrated by Heats of Neutralisation, V. H. Veley, 454; the Sulphur Anion and Complex Sulphur Anions, Joseph Knox, 454; Direct Hydrogenation of the Aromatic Quinones, Paul Sabatier and A. Mailhe, 455; Heat of Vaporisation of Propionic Acid, A. Faucon, 455; the Atomic Weight of Europium, G. Jantsch, 455; Oxidation of Platinum, C. Marie, 455; Synthesis by Means of the Mixed Organometallic Derivatives of Zinc, Ketone Alcohols, E. E. Blaise and I. Herman, 455; Crystallised *d*-Tallite, Gabriel Bertrand and P. Bruneau, 455; Chemische und biologische Untersuchungen von ägyptischen Mumien-material, nebst Betrachtungen über das Einbalsamierungsverfahren der alten Ägypter, W. A. Schmidt, Prof. W. D. Halliburton, F.R.S., 465; Notes on the Application of Low Temperatures to some Chemical Problems, Sir James Dewar and Dr. H. O. Jones, 476; Experimental Examination of Gibbs's Theory of Surface Concentration regarded as the Basis of Absorption, and its Application to the Theory of Dyeing, W. C. M. Lewis, 477; Action of Alkaline Salts with Fixed Base on the Combustion of Gases and Fixed Combustibles, M. Dautriche, 479; a Short Volumetric Method for the Estimation of Sulphuric Acid, Dr. T. Cooksey, 480; Lehrbuch der Chemie und Mineralogie für die vierte Klasse der Realschulen, Franz von Hemmelmayr and Dr. Karl Brunner, 484; Redeterminations of the Atomic Weight of Lead, Gregory P. Baxter and John H. Wilson, 496; Commemorative Dinner to Sir William Ramsay, K.C.B., F.R.S., 500; Solubility of Iodine in Water, H. Hartley and N. P. Campbell, 502; Nitroderivatives of *o*-Xylene, A. W. Crossley and Miss N. Renouf, 502; Substituted Dihydrobenzenes, Part ii., 1:1-Dimethyl- Δ^2 :4-dihydrobenzene and 1:1-Dimethyl- Δ^2 :5-dihydrobenzene, A. W. Crossley and Miss N. Renouf, 502; Traces of a New Tin-group Element in Thorianite, Miss C. de Bretonen Evans, 502; New Isomeride of Vanillin in the Root of Chlorocodon, E. Goulding and R. G. Pelly, 502; Volatile Oil of the Leaves of *Ocimum viride*, E. Goulding and R. G. Pelly, 502; the Sulphonation of Phenolic Ethers and the Influence of Substituents, S. Smiles and R. Le

- Rossgnol, 502; Modern Nitre Beds, 513; Explosive Rhodium, E. Cohen and Th. Strengers, 519; the Production in the Electric Furnace of Carbon Bisulphide, E. R. Taylor, 519; Diffusion and Osmosis, Prof. Stephane Leduc, 519; the Quantitative Determination of Arsenic by the Guzeitz Method, C. R. Sanger and O. F. Black, 519; Action of Chlorine upon Dithymol, H. Cousin, 527; Derivatives of Phenylisoxazolone, A. Wahl and André Meyer, 527; Products of the Action of Aluminium Chloride and Hydrochloric Acid Gas on Benzene, G. Gustavson, 527; Gases arising from Electric Sparks, M. de Broglie, 527; Detection of Minute Quantities of Helium in Minerals, F. Bordas, 527; Derivatives of Thiophene, V. Thomas, 528; Formation of Acetic Aldehyde in Alcoholic Fermentations, A. Trillat, 528; *Traité complet d'Analyse chimique appliquée aux Essais industriels*, J. Post and B. Neumann, 531; Death and Obituary Notice of Dr. James Bell, C.B., F.R.S., 530; Mochus of Sidon and the Theory of Atoms, Dr. T. J. J. See, 541; Dr. Dreyer, 541; Re-determination of the Atomic Weight of Chlorine, W. A. Noyes and H. C. P. Weber, 543; the Society of Dyers and Colourists, 547; the Conversion of Diamond into Coke in High Vacuum by Kathode Rays, Hon. C. A. Parsons, C.B., F.R.S., and Alan A. Campbell Swinton, 549; Action of Heat on α -Hydroxycarboxylic Acids, H. R. Le Sueur, 551; Spontaneous Crystallisation of Sodium Sulphate Solutions, H. Hartley, B. M. Jones, and G. A. Hutchinson, 551; Quantitative Conversion of Aromatic Hydrazines into Diazonium Salts, F. D. Chattaway, 551; Quantitative Separation of Thallium from Silver, J. F. Spencer and M. Le Pla, 551; Density of the Vapour of Propionic Acid, A. Faucon, 552; the OH(1)Cl(2 : 4 : 6)-Trichlorophenol and its Transformation into Chloroquinones, E. Léger, 552; *Chemie der höheren Pilze*, eine Monographie, Dr. Julius Zellner, Prof. R. Meldola, F.R.S., 553; the Chemistry of the Diazo-compounds, Dr. J. C. Cain, 558; the Corrosion of Iron and Steel, Dr. Frank Clowes, 560; Decomposition of Ozone by Heat, Prof. E. P. Perman and R. H. Greaves, 574; an Isomer of Diphenylcamphomethane, A. Haller and E. Bauer, 575; New Method of Estimating the Vapour of Mercury in Air, P. Ménière, 576; Formation of Mixtures of Isomers of Constant Melting Point in the Friedel and Crafts Reaction, G. Perrier and H. Caille, 576; *Untersuchungen in der Puringruppe (1882-1906)*, Emil Fischer, 579; Occurrence of Cyanogenetic Glucosides in Feeding Stuffs, T. A. Henry and S. J. M. Auld, 598; Considerations affecting the "Strength" of Wheat Flours, Julian L. Baker and H. F. E. Hulton, 598; Action of Selenium and Tellurium on Arsine and Stibine, F. Jones, 599; Simple Reaction producing a Disinfectant Gas, G. Carteret, 600; Austenite, Ed. Maurer, 600; New Method of Estimating Phosphorus in Organic Materials, Isidore Bay, 600; Sulphur Compounds of Thorium, A. Duboin, 600; Semicatalysis, the Oxidation of Hydrocarbons in Air in Presence of Phosphorus, Albert Colson, 600; Science and Industry, 621; Reducing Power of Ferropyrrophosphates, P. Pascal, 623
- Chêneveau (C.), Influence of Temperature on the Optical Properties of Dissolved Bodies, 216
- Chevalier (J.), Action of Choline on the Arterial Pressure, 288
- Chevalier (Mr.), a Detailed Study of the Photosphere, 378
- Chicago Meeting of American Association, 283, 302; the Interdependence of Medicine and other Sciences, Dr. W. H. Welch at, 283; Sectional Addresses at the, 378
- Chick (Harriette), Theory of Disinfection, 494
- Child-study, an Introduction to, W. B. Drummond, 410
- Child's Mind, the, its Growth and Training, W. E. Urwick, 410
- Children, Medical Inspection of School, 426
- Chinese Description of the Leaf-insects, Early, Kumagusu Minakata, 173
- Chloroform, the Induction of Anesthesia by, 226
- Chopardet (P.), Comet 1907e (Mellish), 23
- Chree (Dr. C., F.R.S.), Magnetic Declination at Key Observatory, 1890-1900, 238; Atmospheric Electricity and Fog, 343; the Isothermal Layer of the Atmosphere, 437; Magnetic Results obtained by the National Antarctic Expedition of 1901-4, 453; the Ziegler Polar Expedition, 1903-5, Anthony Fiala, 544
- Christie (Sir W. H. M., K.C.B.), the New Eighth Satellite of Jupiter, 575
- Christophers (Captain), the Disease of Dogs due to the Protozoan Parasite *Piroplasma canis*, 444
- Chronology: Public Clocks and Time Distribution, 253; the Sun and the Clock, 372; a Suggested Explanation of the Ancient Jewish Calendar Dates in the Aramaic Papyri, E. B. Knobel, 478; a Simplified Calendar, Alex. Philip, 479; Proposed Alteration in the Calendar, 489; Dr. D. Mackie, 534; Corr., 541
- Chronometry: Determination of the Time, both on Land and at Sea, with the Aid of Wireless Telegraphy, Bouquet de la Grye, 551
- Clark (Alex.), the Polarity of Matter, 219
- Clarke (W. Eagle), the Birds of Yorkshire, 511
- Clay (J.), Variation of the Electrical Resistance of Pure Metals Down to Very Low Temperatures, 233
- Clayton (A.), Residual Affinity of the Coumarins and Thiocoumarins, 383
- Clayton (H. H.), the Lagging of Temperature Changes at Great Heights behind those at the Earth's Surface Shown by Records of Sounding Balloons liberated at St. Louis in April and May, 1906, 495
- Clerc (Louis), New Electric Arc Furnace applicable to Laboratory Researches, 359
- Climate and Man, Prof. Grenville A. J. Cole, 314
- Climber's Pocket Book, the, Rock-climbing Accidents, with Hints on First Aid to the Injured, some Uses of the Rope, Methods of Rescue and Transport, Lionel F. West, 196
- Clock, the Sun and the, 372
- Clocks and Time Distribution, Public, 253
- Clouds, Auroral Characteristics of, George C. Simpson, 344
- Clough (C. T.), the Geological Structure of the North-west Highlands of Scotland, 272
- Clowes (Dr. Frank), the Corrosion of Iron and Steel, 560
- Coal, James Tonge, 389
- Coal Mining, Practical, 457
- Coblentz (W. W.), Relative Merits of the Radiometer, the Linear Thermopile, the Radiometer, and the Bolometer for the Measurement of Radiation, 445
- Cockayne (Dr. L.), Coastal Vegetation of the South Island of New Zealand, 279; Report on a Botanical Survey of Kapiti Island, 297; Vegetation of Disappointment Island, 375; Flora of the Snares and Auckland Islands, 494
- Cockerell (Prof. T. D. A.), a Miocene Wasp, 80
- Cohen (Prof. Ernst), das Lachgas, eine chemisch-historische Studie, 454
- Cohen (E.), Explosive Rhodium, 519
- Cohen (J. B.), Use of Pyridine Bases as Hydrogen Carriers, 335; Organic Chemistry for Advanced Students, 363
- Cohen (L.), Action of Lime on the Available Soil Constituents, 23
- Cohen (Prof.), the So-called Amorphous Antimony and Bismuth, 352
- Coinage, Ancient Dies for, Prof. C. Zenghelis, 65
- Cole (Prof. Grenville A. J.), the Pulse of Asia, a Journey in Central Asia illustrating the Geographic Basis of History, Ellsworth Huntington, 314; *Geologische Prinzipienfragen*, E. Reyer, 529; Deviation of Rivers caused by the Rotational Velocity of the Earth, 612
- Coleman (W. S.), Our Woodlands, Heaths, and Hedges, 554
- College System, Technical Research and the, W. P. Dreaper, 367
- Collier (W. H.), Interaction in Solution of Ferrous Sulphate and Copper Sulphate, 144
- Coloration of Glass and Quartz by Radium, Charles E. S. Phillips, 535
- Colouring Matters of Flowers, on the, Dr. H. C. Sorby, F.R.S., 260
- Colourists, the Society of Dyers and, 547
- Colours and Periods of Variable Stars, the Relations between the, S. Beljawsky, 509
- Colson (Albert), the Transformations of Solutions of White Phosphorus into Red Phosphorus, 287; Semicatalysis, the Oxidation of Hydrocarbons in Air in Presence of Phosphorus, 600

- Columbia, Missouri, and Vicinity, Flora of, F. P. Daniels, 29
- Combes (R.), Microchemical Research applied to the Study of the Distribution of the Saponines in Plants, 240
- Comets: Comet Mellish (1907e), 17, 138; M. Borrelly, 17; G. van Biesbroeck, 17; Dr. M. Ebell, 18, 66; P. Chofardet, 23; Ephemeris for, Dr. Wirtz, 281; Observations of, Dr. J. Holetschek, 353; Search-ephemeris for Comet 1907a (Giacobini), Prof. Weiss, 138; Further Observation of Comet 1907a, Prof. Wolf, 158; Daniel's Comet, 1907d, Herr Kritzing, 208, 544; Ephemeris for Daniel's Comet, 1907d, Herr Kritzing, 421; Observations of, Dr. J. Holetschek, 353; Ephemeris for Encke's Comet, M. Kamensky and Fr. Korolikov, 208, 353; Return of Encke's Comet (1908a), Prof. Wolf, 234, 353; Observation of Encke's Comet on December 25, 1907, Prof. Wolf, 281; Photographic Observations of Encke's Comet (1908a), Prof. Wolf, 302; Encke's Comet, Dr. Backlund, 547; Dr. Ebell, 547; Comets due to return this Year, W. T. Lynn, 258; Perturbations of Halley's Comet in the Past, the Period 1066-1301, A. C. D. Crommelin, 478; the Meteors of Halley's Comet, W. F. Denning, 619; Comet 1907 II., Prof. E. Weiss, 520; the Saturn Perturbations of Various Comets, Dr. Johannes Wendt, 568
- Commerce, Atlas of the World's, 506
- Commerce, the Chemistry of, Robert Kennedy Duncan, 49
- Compas, Déviations des, Pierre Engel, 534
- Computation and Mensuration, P. A. Lambert, 555
- Conchology: Brachiopod Homœomorphy, *Spirifer glaber*, S. S. Buckman, 190
- Concrete Arches, Masonry and, 507
- Concrete Construction, Principles of Reinforced, F. E. Turneure and E. R. Maurer, Supp. to March 5, vi
- Conklin (Dr. E. G.), the Mechanism in Heredity, 378
- Connolly (T. F.), a Bright Meteor, 115
- Conocephalidarum, Revisio, H. Karny, 317
- Consumption, New Treatment for, 254
- Consumption, Sanatoria for, Dr. R. Fielding-Ould, 546
- Continuation Schools in England and Elsewhere, Prof. J. Wertheimer, 361
- Conway (Prof. A. W.), Dynamics of a Rigid Electron, 230
- Cooksey (Charlton D.), the Nature of γ and X-Rays, 509
- Cooksey (Dr. T.), Method for Estimation of Iron, Alumina, and Phosphoric Acid, 263; a Short Volumetric Method for the Estimation of Sulphuric Acid, 480
- Copper and Lithium, the Occurrence of, in Radium-bearing Minerals, Prof. Herbert N. McCoy, 79
- Copper Mirror, a Method of Depositing Copper upon Glass from Aqueous Solutions in a thin, brilliantly reflecting Film, and thus producing a, Dr. F. D. Chattaway, F.R.S., at Royal Society, 380
- Corals of Hawaii, T. Wayland Vaughan, Prof. S. J. Hickson, F.R.S., 499
- Coronal Structure, Prominence and, Dr. William J. S. Lockyer at Royal Society, 514
- Corpuscular Theory of Matter, the, Prof. J. J. Thomson, F.R.S., 505
- Correns (Dr. C.), die Bestimmung und Vererbung des Geschlechtes, 580
- Corstorphine (G. S.), the Occurrence in Kimberlite of Garnet-pyroxene Nodules carrying Diamonds, 224
- Cortie (Father), the Absorption of D_3 (Helium) in the Neighbourhood of Sun-spots, 281; "Stonyhurst Sun Discs," 460
- Cotter (G. de P.), Glaciers in Kumaon, 201
- Cotton Plant, the, Lieut.-Colonel D. Prain, C.I.E., F.R.S., 318, 485; W. Lawrence Balls, 484
- Cotton Plants, the Wild and Cultivated, of the World, a Revision of the Genus *Gossypium*, Sir G. Watt, F. Fletcher, 241
- Couriot (M.), Action of an Incandescent Electric Conductor on the Gases which surround it, 167
- Courtauld (R. M.), Decomposition and Nitrification of Sewage (1) in Alkaline Solution, (2) in Distilled Water, 100-1
- Cousin (H.), the Preparation of Dithymol, 384; Action of Chlorine upon Dithymol, 527
- Coward (H. F.), Direct Combination of Carbon and Hydrogen, 359
- Coward (T. A.), the Greater Horse-shoe Bat in Captivity, 599
- Cowell (P. H.), Perturbations of Halley's Comet in the Past, the Period 1066-1301, 478
- Cowper (A. D.), Intensity of Spectrum Lines, 248
- Cradle Tales of Hinduism, Margaret E. Noble, 605
- Craniology: Head of Australian Aborigine, Prof. Cunningham, 139; on the Cranial and Facial Characters of the Neanderthal Race, Prof. W. J. Sollas, 262; Human Skull from the Historic Period presenting Indications of Close Affinity with the Spy-Neanderthal Type, K. Stolyhwo, 587
- Cremieu (Dr. Victor), Apparatus for Extinguishing the Rolling of Ships, 114
- Cretaceous Flora of Southern New York and New England, the, Arthur Hollick, 121
- Cretan Exploration, Dr. Arthur J. Evans, F.R.S., 163
- Crété (L.), Researches on the Pulp called *Netté Flour*, 336
- Crocodiles and Sleeping Sickness, Connection between, Prof. Koch, 16
- Crommelin (A. C. D.), Perturbations of Halley's Comet in the Past, the Period 1066-1301, 478; the New Eighth Satellite of Jupiter, 575
- Crookes (Sir William, F.R.S.), Scientific Worthies, Prof. P. Zeeman, 1
- Cross (W. E.), Use of Pyridine Bases as Hydrogen Carriers, 335
- Crossley (A. W.), Nitroderivatives of *o*-Xylene, 502; Substituted Dihydrobenzenes, Part II., 1:1-Dimethyl- $\Delta^{2:1}$ -dihydrobenzene and 1:1-Dimethyl- $\Delta^{2:1}$ -dihydrobenzene, 502
- Crowther (J. A.), the Fatigue of Secondary Radiation due to Radium Rays, 167; the Scattering of the β Rays from Uranium by Matter, 358
- Crozier (J. D.), the Douglas Fir as a Commercial Timber Tree, 419
- Crustacea: Young Stages of Fresh-water American Crayfishes, Prof. E. A. Andrews, 87; South African Crustaceans, Rev. T. R. R. Stebbing, 613
- Crystallography: Measurement of the Anomalous Dispersion in Crystals at Different Temperatures, Jean Becquerel, 95; Relation between Isomorphous Miscibility and Parallel Growths, T. V. Barker, 143; Twin Structure, Dr. John W. Evans, 358; a Simple Method of drawing Rhombohedral Crystals and of deducing the Relations of their Symbols, Prof. W. J. Lewis, 358; the Structure of Perowskite, H. L. Bowman, 385; Crystallised *d*-Talite, Gabriel Bertrand and P. Bruneau, 455
- Culin (Stewart), the Games of the North American Indians, 568
- Cumming (A. C.), Malacoe, a Silicate of Zirconium, 383
- Cunningham (Lieut.-Colonel D. D.), Plagues and Pleasures of Life in Bengal, 223
- Cunningham (J. T.), the Interpretation of Mendelian Phenomena, 54; the Inheritance of "Acquired" Characters, 367
- Cunningham (Prof.), Head of Australian Aborigine, 139
- Cure and Prevention of Sleeping Sickness, the, 36
- Curie (Madame), Re-determination of the Atomic Weight of Radium, 65; Condensation of Water Vapour in the Presence of Radium Emanation, 167
- Curties (C. L.), Two Inexpensive Microscopes, 188
- Curtis (C. C.), Nature and Development of Plants, 436
- Curtis (Dr. Heber D.), Temperature Control of Silvered Mirrors, 137; Orbits of Spectroscopic Binaries, 138
- Cytology, the Essentials of, Charles Edward Walker, 410
- Dadourian (H. M.), Atmospheric Radio-activity at New Haven, 615
- Dalby (Prof. W. E.), Measurement of Temperatures in the Cylinder of a Gas Engine, 141
- Dancing Mouse, the, a Study in Animal Behaviour, Robert M. Yerkes, 533
- Danforth (C. H.), New Pteropod Mollusc, *Paedocione dolioformis*, 325
- Daniel (Lucien), Production of Grapes without Pips, 48
- Daniel's Comet, 1907d, Herr Kritzing, 208; Ephemeris for, Herr Kritzing, 421
- Daniell (G. F.), Science at Recent Educational Conferences, 281

- Daniels (F. P.), Flora of Columbia, Missouri, and Vicinity, 29
- Dannemann (Dr. F.), der naturwissenschaftliche Unterricht auf praktisch-heuristischer Grundlage, Supp. to March 5, viii
- Darbishire (A. D.), Result of Crossing Round with Wrinkled Peas, with Especial Reference to their Starch-grains, 382
- Darwin (Sir G. H., K.C.B., F.R.S.), Further Consideration of the Stability of the Pear-shaped Figure of a Rotating Mass of Liquid, 430
- Daufreime (Maurice), *p*-Methoxycinnamic Aldehyde in Essence of Estragon, 96
- Daunt (Captain), the Helium, D₂, Line in the Solar Spectrum, 520
- Dauriche (M.), Action of Alkaline Salts with Fixed Base on the Combustion of Gases and Fixed Combustibles, 479
- Davies (C. T.), Hybrids, 213
- Davies (F. H.), Electric Power and Traction, 74
- Davis (B. M.), Laboratory and Field Manual of Botany, 554
- Davis (Harvey N.), a Convenient Formula in Thermodynamics, 80
- Davis (William J.), the Birds of Kent, 122
- Davison (C.), Plane Geometry for Secondary Schools, 315
- Davy's Discovery of the Metals of the Alkalis, the Centenary of, Prof. T. E. Thorpe, C.B., F.R.S., at Royal Institution, 305
- Dawson (H. M.), Influence of Foreign Substances on certain Transition Temperatures and the Determination of Molecular Weights, 383
- Dawson (W. Bell), Tidal Investigations in Canada, 202
- Daylight, on the Incidence of, as a Determining Factor in Bird-migration, Prof. E. A. Schäfer, F.R.S., 159
- Death, Possibility of Establishing the Diagnosis of, by Radiography, Charles Vaillant, 96
- Delage (Yves), the Phenols as Parthenogenetic Agents, 47
- Delagrangé's (M.) Aeroplane, 564
- Delauney (M.), Attempt at Proving certain Relations between the Atomic Weights of the Elements, 215
- Demousse (E.), Influence of the Hygrometric State of the Air on the Preservation of Seeds, 168
- Dendy (Prof. Arthur), Report on Scenery Preservation for the Year 1906-7, 297; Report on a Botanical Survey of Kapiti Island, L. Cockayne, 297
- Denemar (W. K.), Excitability and Conductibility of Nerves exposed to the Action of Distilled Water, 498
- Denning (W. F.), the Great Red Spot on Jupiter, 42; the Meteors of Halley's Comet, 619
- Desgrez (A.), Action of Choline on the Arterial Pressure, 288
- Deslandres (H.), Apparatus designed for Stars composed partly of Gas and partly of Solid Particles, 107
- Dévaux-Charbonnel (M.), Propagation of Telephone Currents through Subterranean Lines, 167; Conditions of Maximum Yield for Telephonic Apparatus, 215
- Dewar (Sir James, F.R.S.), Use of the Radiometer in observing Small Gas Pressures, 22; Notes on the Application of Low Temperatures to some Chemical Problems, 476
- Dewey (Henry), Origin of the Pillow-lava near Port Isaac, in Cornwall, 358
- Diabolo Experiment, a, C. V. Boys, 188
- Diamantiferous Rock of Kimberley, the, Prof. T. G. Bonney, F.R.S., 248
- Diamond-making: M. Lemoine's Case, 254
- Diazo-compounds, the Chemistry of, Dr. J. C. Cain, 558
- Dick (A. B.), Supplementary Notes on Kaolinite, 575
- Diels (Dr. L.), die Vegetation der Erde, vii., die Pflanzenwelt von West Australien südlich des Wendekreises, 171
- Diener (Dr. Carl), Fauna of the Tropics Limestone of Byans, South-west Himalayas, 116
- Difloth (Prof. Paul), (1) Races bovine, France—Étranger, (2) Races chevalines, 339
- Dines (W. H., F.R.S.), the Isothermal Layer of the Atmosphere, 390, 462
- Disease, an Essay upon, its Cause and Prevention, Dr. G. E. Richmond, 365
- Disease-resisting Sugar-canes, Sir D. Morris, K.C.M.G., 438
- Diseases of Animals, the, Nelson S. Mayo, 436
- Disinfectants, the Bacteriological Examination of, William Partridge, Prof. R. T. Hewlett, 246
- Disinfection, Theory of, Harriette Chick, 494
- Dispersion, the Theory of, and Spectrum Series, Norman R. Campbell, 607
- Distant (W. L.), the Extermination of Animals by Man, 113
- Dobell (C. C.), New Flagellate Monad (*Copromonas subtilis*), 350
- Doberck (Prof.), the Accuracy of Double-star Measures, 328
- Doberck (Dr.), the Orbit of γ Virginis, 446
- Dogs, the Disease of, due to the Protozoan Parasite *Piroplasma canis*, Captain Christophers, 444
- Donitch (M.), Eclipse Observations, August, 1905, 281
- Dorsey (N. E.), Maxwell's Bridge Method of determining the Ratio of the Electromagnetic to the Electrostatic Unit of Electricity, 136
- Double-star Measures, the Accuracy of, Prof. Doberck, 328
- Double-star Observations, Dr. Joel Stebbins, 401
- Double Stars, Measures of, C. P. Olivier and R. E. Wilson, 281
- Double Stars, Two Hundred New, Prof. Aitken, 328
- Douglas (Dr. Carstairs G.), the Laws of Health, a Handbook on School Hygiene, 197
- Doumer (E.), Electrolysis of Solutions of Hydrochloric Acid, 407
- Dowling (D. B.), the Cascade Coal Basin, Alberta, 380
- Downing (Dr.), Occultation of Neptune by the Moon, 42; Comparisons of the Places of Mars for the Oppositions of 1907 and 1909, 67; Occultations of Uranus in 1908, 353
- Drapers' Company Research Memoirs, ii., a First Study of the Statistics of Pulmonary Tuberculosis, Prof. Karl Pearson, F.R.S., 394
- Dreaper (W. P.), Technical Research and the College System, 367
- Dress, the Heritage of, being Notes on the History and Evolution of Clothes, W. M. Webb, Supp. to March 5, vii
- Dreyer (J. L. E.), an Alleged Originator of the Theory of Atoms, 368; Mochus of Sidon and the Theory of Atoms, 541
- Drifted Ice-crystals, Dr. Walter Leaf, 271
- Drummond (Margaret), Elements of Psychology, 267
- Drummond (W. B.), an Introduction to Child-study, 410
- Drysdale (Dr. C. V.), the Plug Permeameter, 575
- du Toit (A. L.), the Sutherland Volcanic Pipes and their Relationship to other Vents in South Africa, 224; Geological Survey of the Eastern Portion of Griqualand West, 224
- Dublin: Dublin Royal Society, 191, 239, 407, 455; the New School of Botany, Trinity College, 260; the Forthcoming Dublin Meeting of the British Association 608
- Duboin (A.), some Iodomercurates, 23; Sulphur Compounds of Thorium, 600
- Duboisi (Raphael), Influence of Sunlight on the Disengagement and on the Orientation of the Gaseous Molecules in Solution in Sea-water, 431
- Duckworth (A.), Comparison of the Rainfall of Sydney and Melbourne, 187-6 to 1905, 470
- Duckworth (Dr.), Method of demonstrating Syncytial Appendages of the Placental Villi, 470
- Duckworth (Dr. W. L. H.), Brains of Australian Natives, 64
- Duclaux (J.), the Diastatic Function of Colloids, 95
- Dudeny (H. E.), the Canterbury Puzzles and other Curious Problems, 341
- Duerden (Prof. J. E.), Rate of Growth of Ostrich Feathers, 180; the "Waltzing Instinct" in Ostriches, 278
- Dufour (A.), an Exceptional Case of Zeeman's Phenomenon, 311; Lines presenting a Zeeman Phenomenon Abnormal in the Sense of the Magnetic Lines of Force, 527; Effect of Pressure on the Wave-lengths of the Absorption Lines of Nitrogen Peroxide and Bromine, 589

- Dunbar (Prof.), Stages in the Life-history of Green Alga, 350
- Duncan (J.), Steam and other Engines, 29
- Duncan (Robert Kennedy), the Chemistry of Commerce, 49
- Duncan (W. Stewart), the Evolution of Matter, Life, and Mind, 30
- Dunstan (B.), the Stanhills Tinfields near Croydon, 257; the Great Fitzroy Copper and Gold Mine, Queensland, 468
- Duparc (Louis), *Traité de Chimie analytiques qualitative, suivi de Tables systématiques pour l'Analyse minérale*, 437
- Durand (E.), Formation of Ozone by the Action of the Silent Discharge at Low Temperatures, 215
- Durand (Prof. W. F.), Researches on the Performance of the Screw Propeller, 416
- Durham (Edith), Montenegrin Manners and Customs, 454
- Dutt (W. A.), Small Flint Implements from Bungay, 102
- Dyeing in Germany and America, Sidney H. Higgins, Prof. Walter M. Gardner, 4
- Dyeing, Experimental Examination of Gibbs's Theory of Surface Concentration regarded as the Basis of Absorption, and its Application to the Theory of, W. C. M. Lewis, 477
- Dyers and Colourists, the Society of, 547
- Dynamics of a Rigid Electron, Prof. A. W. Conway, 239
- Dyson (Prof.), Systematic Motions of the Stars, 616
- Ear, on the Impulses of Compound Sound Waves and their Mechanical Transmission through the, Sir Thomas Wrightson, Bart., 289
- Earth's Heat, Radium and, Prof. Harold A. Wilson, F.R.S., 365; Hon. R. J. Strutt, F.R.S., 365
- Earthquakes: Earthquake in Bokhara, 14; Earthquake in Jamaica, 230; Jamaica Earthquake of January 2, 1908, Maxwell Hall, 542; the Californian Earthquake of 1906, 251; Earthquakes, an Introduction to Seismic Geology, William Herbert Hobbs, 481; Earthquake in Mexico and at St. Thomas, 516; Recent Earthquakes, Prof. J. Milne, F.R.S., at Royal Institution, 592
- Ebell (Dr. M.), Comet Mellish (1907e), 18, 66; Encke's Comet, 547
- Ebrill (G.), Derivatives of Xylose, 191
- Echelon Spectroscopie, H. Stansfield, 108, 222
- Eclipses: the Total Solar Eclipse of January 3, 1908, Dr. W. J. S. Lockyer, 104, 274; the Recent Total Solar Eclipse, 544; Eclipse Observations, August, 1905, M. Donitch, 281; Spanish Observation of the Total Solar Eclipse of August, 1905, 446; Mutual Occultations and Eclipses of Jupiter's Satellites, Mr. Whitwell, 567
- Edelmann (Dr. M., jun.), the Filament Electrometer, 401
- Edgar (Dr. E. C.), the Atomic Weight of Chlorine, 350
- Edgeworth (Prof. H. F.), Muscles of the Head in Birds and Reptiles, 155
- Edinburgh Royal Society, 311, 335, 407, 431, 479, 551; Lord Kelvin and the, 255
- Education: the New Municipal Technical Institute, Belfast, 18; London Day Training College for Teachers, 107; the Increased Endowment of Universities, 152; Education and Research in India, 202; the Practice of Instruction, 243; Science at Recent Educational Conferences, G. F. Daniell, 281; the Place of Nature-study in the School Curriculum, Dr. Percy T. Nunn, 282; Order in which Scientific Ideas should be Presented, Prof. H. A. Miers, F.R.S., 283; the Education of Tomorrow, John Stewart Remington, 292; Examination v. Research, Dr. F. C. S. Schiller, 322; Death of W. A. Shenstone, F.R.S., 324; Obituary Notice of, Prof. William A. Tilden, F.R.S., 348; Mathematical Education and Research, 331; Report of the Education Committee of the London County Council submitting the Report of the Medical Officer (Education) for the Year ended March 31, 1907, Dr. James Kerr, 355; Continuation Schools in England and Elsewhere, Prof. J. Wertheimer, 361; Technical Research and the College System, W. P. Dreaper, 367; an Introduction to Child-study, W. B. Drummond, 410; the Child's Mind, its Growth and Training, W. E. Urwick, 410; Memorandum on Medical Inspection of Children in Public Elementary Schools, under Section 13 of the Education (Administrative Provisions) Act, 1907, 426; Memorandum by the British Medical Association on the Circular of the Board of Education, 426; Extensions at University College, London, 525; Jubilee of the Calcutta University, 584; Educational Leakage, V. A. Mundella, 617; der naturwissenschaftliche Unterricht auf praktisch-heuristischer Grundlage, Dr. F. Dannemann, Suppl. to March 5, viii
- Egg of the Platypus, the, the Reviewer, 80
- Eggs, the Preservation of, Fr. Prall, 84, 137
- Egypt: Zoology of Egypt, the Fishes of the Nile, G. A. Boulenger, F.R.S., 10; Hydrology in Egypt, Captain H. G. Lyons, 21; a Description of the First or Aswan Cataract of the Nile, Dr. John Ball, 433; Distribution of Standard Time in Egypt, Captain H. G. Lyons, 497; Magnetic Observations in Egypt, 1895-1905, 565
- Egyptology: Ancient Egypt the Light of the World, a Work of Reclamation and Restitution, Gerald Massey, 291; Burial Customs of Ancient Egypt, Prof. J. Garstang, H. R. Hall, 439; Chemische und biologische Untersuchungen über das Einbalsamierungsverfahren der alten Ägypter, W. A. Schmidt, Prof. W. D. Halliburton, F.R.S., 465
- Elasticity, a Point in the Mathematical Theory of, H. M. Martin, 198; Prof. E. Brown, 221
- Elberts (Dr. J.), the Fossiliferous Deposits of the Bengawan River in Java, 299
- Elder (Harry M.), Tabulated Values of certain Integrals, 486
- Electricity: Steady Deflection Method of Current Measurement with an Electrometer, Prof. J. A. Pollock, 24; Simple Method of Generating an Alternating Current of any Desired Frequency, Dr. Rudenberg, 41; Conditions which Influence the Production of Rapid Electrical Oscillations by Means of the Arc, L. W. Austin, 41; Chemical Changes occurring when Air is Submitted to the Influence of Electricity, E. Warburg and G. Leithäuser, 41; the Wehnelt Kathode in a High Vacuum, Frederick Soddy, 53, 197; Prof. O. W. Richardson, 197; Wireless Telegraphy Apparatus on Board French Warships, 62; New Transatlantic Wireless Station at Knockree, the Poulsen System of Wireless Telegraphy by Undamped Waves, 88; Magnetic Oscillators as Radiators in Wireless Telegraphy, Dr. J. A. Fleming, 71; the Use of Variable Mutual Inductances, A. Campbell, 71; Electric Power and Traction, F. H. Davies, 74; Arrangement for Measuring the Resistance of Electrolytes without the Use of Electrodes, Prof. W. S. Franklin and L. A. Freudenberger, 89; a Text-book of Electrical Engineering, Dr. Adolf Thomäen, 124; the Elements of Electrical Engineering, Prof. W. S. Franklin and Wm. Esty, 124; Maxwell's Bridge Method of determining the Ratio of the Electromagnetic to the Electrostatic Unit of Electricity, E. B. Rosa and N. E. Dorsey, 136; Sulphur as an Insulator, Rev. F. J. Jervis-Smith, F.R.S., 149; the Normal Weston Cadmium Cell, F. E. Smith, 165; the Silver Voltmeter, F. E. Smith, 165; Chemistry of the Silver Voltmeter, F. E. Smith and Dr. T. M. Lowry, 165; Action of an Incandescent Electric Conductor on the Gases which surround it, M. Couriot and Jean Meunier, 167; Electric Traction, Prof. Ernest Wilson and Francis Lydall, Gisbert Kapp, 169; the Photoelectric Property of Selenium, Prof. George M. Minchin, F.R.S., 173, 222; Richard J. Moss, 198; Dr. Shefford Bidwell, F.R.S., 198; Old and New Methods of Galvanising, Alfred Sang, 179; the Electrical Conductivity of Aqueous Solutions, Arthur A. Noyes, 213; Conductivity and Viscosity in Mixed Solvents, Harry C. Jones, 213; Conditions of Maximum Yield for Telephonic Apparatus, Henri Abraham and M. Devaux-Charbonnel, 215; Formation of Ozone by the Action of the Silent Discharge at Low Temperatures, E. Briner and E. Durand, 215; Variation of the Electrical Resistance of Pure Metals down to Very Low Temperatures, Prof. H. Kamerlingh Onnes and J. Clay, 233; Dynamics of a Rigid Electron, Prof. A. W. Conway, 239; the Electrolytic Reduction of Indigo, Henri Chaumat, 239; Use of Flames as Valves for Alternating High-tension Currents, André Cathiard, 263; Investigation on the Clark and Weston Standard Cells, F. A. Wolf and C. E. Waters, 280; Inductance in Parallel Wires, Dr. J. W. Nicholson, 295; Electrical Phenomena

of the Atmosphere and their Relations with Solar Activity, Prof. Schuster, 301; Verification of Ohm's Law, Prof. Lecher, 304; Electrical Discharge in Monoatomic Gases, F. Soddy and T. D. Mackenzie, 310; Theory of a Receiver consisting of a Comparatively Short Vertical Wire, Dr. J. Zenneck, 327; Atmospheric Electricity and Fog, Dr. Charles Chree, F.R.S., 343; the Electromagnetic Theory of Dispersion in Gases, L. Natanson, 352; New Electric Arc Furnace applicable to Laboratory Researches, Louis Clerc and Adolphe Minet, 359; Lehrbuch der theoretischen Elektrochemie auf thermodynamischer Grundlage, J. v. Jan Laar, 380; the Filament Electrometer, Dr. C. W. Lutz and Dr. M. Edelmann, jun., 401; Electrolysis of Solutions of Hydrochloric Acid, E. Doumer, 407; a Fundamental Contradiction between the Electrical Theory of Dispersion and the Phenomena of Spectrum Series, Dr. G. A. Schott, 413; Modern Views on Electricity, Sir Oliver Lodge, F.R.S., 438; Cours d'Electricité, H. Pellat, 458; les Découvertes modernes en Physique, O. Manville, 458; Measurement of the Zeeman Effect for the Principal Lines of Helium, Dr. W. Lohmann, 470; Contact Potential Differences determined by Means of Null Solutions, S. W. J. Smith and H. Moss, 477; Distribution in Electric Fields of the Active Deposits of Radium, Thorium, and Actinium, S. Russ, 503; the Corpuscular Theory of Matter, Prof. J. J. Thomson, F.R.S., 505; the Production in the Electric Furnace of Carbon Bisulphide, E. R. Taylor, 519; Gases arising from Electric Sparks, M. de Broglie, 527; Armature Construction, H. M. Hobart and A. G. Ellis, 532; the Electric Propulsion of Ships, H. A. Mavor, 543; the Conversion of Diamond into Coke in High Vacuum by Kathode Rays, Hon. C. A. Parsons, C.B., F.R.S., and Alan A. Campbell Swinton, 549; Handbuch der Physik, Dr. A. Winkelmann, 559; Electrical Equipment of Gold Mines, H. J. S. Heather, 575; an Extremely Sensitive Electric Hygroscope, J. Pinchon, 600; Comparative Electrophysiology, Prof. J. C. Bose, Supp. to March 5, iii; Modern Views of Electricity, Sir Oliver Lodge, F.R.S., Supp. to March 5, viii

Ellet (Sir John, K.C.I.E., F.R.S.), Memoirs of the Indian Meteorological Department, being Occasional Discussions and Compilations of Meteorological Data relating to India and Neighbouring Countries, vol. xviii., part iii., v., a Discussion of the Anemographic Observations recorded at Allahabad from September, 1890, to August, 1904; vi., a Discussion of the Anemographic Observations recorded at Lucknow from June, 1878, to October, 1892, 353

Ellet (Sir John, K.C.I.E., F.R.S.), Death of, 467; Obituary Notice of, 490

Ellery (Lieut.-Colonel R. L. J., C.M.G., F.R.S.), Death of, 254; Obituary Notice of, 208

Elliott (G. F. Scott), the Romance of Savage Life, describing the Life of Primitive Man, his Customs, Occupations, Language, Beliefs, Arts, Crafts, Adventures, Games, Sports, &c., 171

Elliott (Prof. E. B.), the Projective Geometry of some Covariants of a Binary Quintic, 478

Ellis (A. G.), Armature Construction, 532

Ellis (H. Russell), Action of Aluminium Powder on Silica and Boric Anhydride, 47

Ellis (H. R.), Interaction in Solution of Ferrous Sulphate and Copper Sulphate, 144

Ellis (W., F.R.S.), Summary of Greenwich Air-temperature Observations, 1841-1905, 206

Elsden (J. V.), the St. David's Head "Rock Series," 406

Embryology: Experimental-Zoologie, Dr. Hans Przibram, 529

Encke's Comet, 1908a, Ephemeris for, M. Kamensky and Fr. Korolikov, 208; Return of, Prof. Wolf, 234; Observation of, on December 25, 1907, Prof. Wolf, 281; Photographic Observations of, Prof. Wolf, 302; Encke's Comet, 1908a, M. Kamensky and Mdlle. Korolikov, 353; Prof. Wolf, 353; Dr. Backlund, 547; Dr. Ebell, 547

Endowment of Universities, the Increased, 152

Energétique, l', et le Mécanisme au Point de Vue des Conditions de la Connaissance, Abel Rey, 580

Engel (Pierre), Déviations des Compas, 534

Engineering: Institution of Civil Engineers' Awards for 1906-7, 14; Inaugural Address at Institution of Civil Engineers, Sir William Matthews, K.C.M.G., 14; Steam and other Engines, J. Duncan, 29; the *Mauretania*, 41; Engineering Workshop Practice, Charles C. Allen, 28; the Development of the American Locomotive, 65; Electric Power and Traction, F. H. Davies, 74; Liquid and Gaseous Fuels and the Part they Play in Modern Power Production, Prof. V. B. Lewes, 98; Death of M. Walton Brown, 111; a Text-book of Electrical Engineering, Dr. Adolf Thomäen, 124; the Elements of Electrical Engineering, Profs. W. S. Franklin and Wm. Esty, 124; Experiments on Wind-pressure, Dr. T. E. Stanton, 139; the Predetermination of Train-resistance, C. A. Carus-Wilson, 156; Electric Traction, Prof. Ernest Wilson and Francis Lydall, Gisbert Kapp, 169; Gyroscope illustrating Brennan's Mono-railway, Prof. H. A. Wilson, 189; an Experimental Study of Stresses in Masonry Dams, Karl Pearson, F.R.S., A. F. Campbell Pollard, C. W. Wheen, and L. F. Richardson, Prof. E. Brown, 209; the Stresses in Masonry Dams, H. M. Martin, 269, 320, 392; Sir Oliver Lodge, F.R.S., 269; Prof. Karl Pearson, F.R.S., 269, 366; Sir John W. Otley, K.C.I.E., and Dr. A. W. Brightmore, J. S. Wilson, and W. Gore, at Institution of Civil Engineers, 303; a Point in the Mathematical Theory of Elasticity, H. M. Martin, 198; Prof. E. Brown, 221; the Place of the Laboratory in the Training of Engineers, Prof. A. L. Mellanby at Institution of Engineers and Shipbuilders in Scotland, 211; Clean Water and How to Get It, Allen Hagen, 218; Influence of the Thickness of the Pipe Wall on the Rate of Discharge of Water from Minute Orifices piercing the Pipe, W. R. Baldwin-Wiseman, 231; Tests of Reinforced Concrete Beams, A. N. Talbot, 232; Road-making and Maintenance, Thomas Aitken, 244; Death of Prof. C. D. West, 254; Death and Obituary Notice of J. Macfarlane Gray, 277; Building as an Engineering Work in New York, 301; Death and Obituary Notice of Dr. Coleman Sellers, 325; Experiments on Premier Company's Gas Engine, Prof. F. W. Burstal, 326; Inter-relation of the Theory and Practice of Shipbuilding, J. J. O'Neill, 327; Problems in Strength of Materials, Dr. William Kent Shephard, 365; Whittaker's Arithmetic of Electrical Engineering for Technical Students and Engineers, 365; the Phenomenon of Soft Steel Disc Revolving at a High Speed Cutting Hard Steel, F. W. Harbord, 419; the Shaft Sinking at the Horden Colliery, South-east Durham, J. J. Prest, 420; High Steam-pressures in Locomotive Service, W. F. M. Goss, 445; the Use of Gyrostats, Prof. J. Perry, F.R.S., at Physical Society, 447; Practical Coal Mining, 457; Symmetrical Masonry Arches, M. A. Howe, 507; the Electric Propulsion of Ships, H. A. Mavor, 543; Practical Calculations for Engineers, C. E. Larard and H. A. Golding, 555; the Practical Application of Reinforced Concrete, M. Kahn, 566; Effect of Mixture Strength and Scavenging upon Thermal Efficiency, Prof. Bertram Hopkinson, 588; some Unsolved Problems in Metal-mining, "James Forrest" Lecture at Institution of Civil Engineers, Prof. Henry Louis, 619; Principles of Reinforced Concrete Construction, F. E. Turneure and E. R. Maurer, Supp. to March 5, vi

Entomology: Entomological Society, 22, 71, 166, 189, 430, 477, 550; the Symphyla, S. R. Williams, 39; New Dipterid Larva, *Acanthomera tetratruncum*, from Paraguay, Karl Fiebrig, 63; Précis des Caractères génériques des Insectes, disposés dans un Ordre naturel par le Citoyen Latreille, 77; the Habits, Life-history, and Breeding-places of the House-fly, R. Newstead, 135; New Acari from New Zealand, A. D. Michael, 142; Trumpet Leaf-miner of the Apple, *Tischeria malifoliella*, A. L. Quaintance, 156; Early Chinese Description of the Leaf-insect, Kumagusu Minakata, 173; the Story of Insect Life, W. P. Westell, Fred. V. Theobald, 175; the Apple Sucker, Spraying Experiments, Kenneth G. Furley, 180; Dragon-flies from Central Australia, R. J. Tillyard, 102; Australian Genus *Petalura*, Dragon-fly, R. J. Tillyard, 102; the Dragon-flies of South-western Australia, R. J. Tillyard, 102; Wild Bees, Wasps and Ants, and other Stinging Insects, Edward Saunders,

- F.R.S., 220; Death and Obituary Notice of Dr. H. G. Knaggs, 278; Chrysanthemum Powder as a Means of Destroying Mosquitoes in Houses, Dr. A. L. Herrera, 278; Life-history of the Warble-flies *Hypoderma lineata* and *H. bovis*, Drysdale Turner, 270; the Melanic Variety of the "Peppered Moth," A. Bacot, 294; the Sense of Sight in Spiders, Dr. Alexander Petrunkevitch, 350; a Guide to the Study of Australian Butterflies, W. J. Rainbow, 411; Death of Prof. Willis G. Johnson, 541; Three Pereute Species from the Chanchamayo District of Peru, W. J. Kaye, 551; Insects Injurious to Salforests of Assam, Mr. Stebbing, 587
- Epstein (T.), Sun-spot Observations, 544
Eredia (Dr.), Rainfall of the Ligurian Riviera, 301
Eros, Observations of, G. Van Biesbroeck, 590
Eruptive Prominence, a Large, Mr. Fox, 90
Esmiol (M.), the Recent Transit of Mercury, 116
Esty (Prof. Wm.), the Elements of Electrical Engineering, 124
- Ethnology: New Facts about the Arunta, M. Freiherr v. Leonhardi, 44; Literature relating to the Australian Aborigines, Dr. A. W. Howitt, 80; R. H. Mathews, 81; Notes on some Bushman Crania and Bones from the South African Museum, Cape Town, Dr. F. C. Shruballs, 211; American Ethnology, Dr. J. W. Fawkes, 329; Death of Dr. A. W. Howitt, C.M.G., 443; Obituary Notice of, Dr. A. C. Haddon, F.R.S., 515; the Games of the North American Indians, Stewart Culin, Dr. A. C. Haddon, F.R.S., 568; Ancient Britain and the Invasions of Julius Caesar, Dr. T. Rice Holmes, 601
- Etiology and Epidemiology of Plague, Major G. Lamb, 585
Europe prehistoric, P., Sophus Müller, Dr. William Wright, 578
- Evans (Dr. Arthur J., F.R.S.), Cretan Exploration, 163
Evans (Miss C. de Breton), Traces of a New Tin-group Element in Thorianite, 502
Evans (Sir John), Recent Discoveries of Palæolithic Implements, 214
Evans (Dr. John W.), Twin Structure, 358; the Possibility of Life in Mars, 302, 413; Helium in the Atmosphere, 535; New Form of Quartz-wedge, 575
Eve (Prof. A. S.), the Penetrating Radiation, 486
Eveland (A. J.), Geology of Baguio Mineral District, Manila, 186
- Everdingen (Dr. E. Van), Relations between Mortality of Infants and High Temperatures, 206
Evershed (J.), Ultra-violet Region in Sun-spot Spectra, and Spectrum of Comet *d* 1907, 94
- Evolution: the Evolution of Matter, Life, and Mind, W. Stewart Duncan, 30; sur la Transmissibilité de Caractères acquis, Eugenio Rignano, 103; Evolution of Planets, Edwin G. Camp, W. E. Rolston, 105; Evolution and Animal Life, David Starr Jordan and Vernon Lyman Kellogg, 242; Evolution of Astronomical Instruments, Joh. A. Repsold, 409; Evolution of Mammalian Molar Teeth, to and from the Triangular Type, H. F. Osborn, 438; the Heritage of Dress, being Notes on the History and Evolution of Clothes, W. M. Webb, Supp. to March 5, vii
- Examination v. Research, Dr. F. C. S. Schiller, 322
Existence, the Case of, Norman Allison, 53
Exner (Prof. F.), Cause of the Slight Variability of Wavelength of Spectral Lines, 304
- Fabry (Ch.), Presence of Spark Lines in the Arc Spectrum, 579
Fairland of Living Things, the, R. Kearton, 147
Faraday Society, 47, 214, 454
Farman (Henry), the Deutsch-Archædeacon Prize won by, 254; H. Farman and his Aeroplane, 403
Farr (E. M.), the Flora of the Canadian Rocky Mountains, 541
Farrington (Prof. O. C.), Analyses of Meteoric Irons, 13
Faucon (A.), Heat of Vaporisation of Propionic Acid, 455; Density of the Vapour of Propionic Acid, 552
Fauna of Madagascar, the, Frank E. Beddard, F.R.S., 8
Fauth (Ph.), the Moon in Modern Astronomy, 195
Fawcitt (Dr. C. E.), Determination of Viscosity at High Temperatures, 502
Fenton (Dr.), Action of Metallic Magnesium on Aliphatic Acids, and the Detection of Formic Acid, 190; Colour-reactions of Organic Acids with Phenols, 190
Fényi (Father), the Large Solar Prominence of May 21, 1907, 446
Fermentation, Influence of Light and of Copper on, J. E. Purvis and W. A. R. Wilks, 191
Fermor (L. L.), Indian Meteorites, 13
Ferrari (H. T.), National Antarctic Expedition, 1901-4, Geology of South Victoria Land, 561
Féry (Charles), Simple Calorimeter for Gases and Liquids, 182; the Caloric Solar Radiation, 359
Fewkes (Dr. J. W.), American Ethnology, 329
Fiala (Anthony), the Ziegler Polar Expedition, 1903-5, 544
Fiebrig (Karl), New Dipterid Larva, *Acanthomera tetra-truncum*, from Paraguay, 63
Fielding-Ould (Dr. R.), Sanatoria for Consumption, 546
Fierz (H. E.), the Triazo-group, part ii., Azoimides of Propionic Ester and of Methyl Ethyl Ketone, 431
Filtration of Rain Water, Enquirer, 272
Finley (W. L.), the Californian Condor, 255
Fiorentino (Prof. Aristide), School-room Experiment for showing the Absorption of Energy by an Acoustic Resonator, 567
Fischer (Emil), Untersuchungen in der Puringruppe (1882-1906), 579
Fischer (Prof. Martin H.), the Physiology of Alimentation, 26
Fisheries: Reports on the Sea and Inland Fisheries of Ireland for 1904 and 1905, E. W. L. Holt, 374; Marking and Transplantation Experiments with Plaice in Danish Waters, A. C. Johansen, 418; the North Sea Fisheries Investigations, Frank Balfour Browne, 523; Age and Growth-rate of Plaice in the Southern North Sea determined by the Otolith, Dr. Wallace, 503; the Food of Fishes, R. A. Todd, 524
Fishes: the Fishes of the Nile, G. A. Boulenger, F.R.S., 10; the Life of the Salmon, with Reference more Especially to the Fish in Scotland, W. L. Calderwood, 173
Fishing: Sunshine and Sport in Florida and the West Indies, F. G. Aflalo, 128
Fison (Rev. Dr. Lorimer), Death and Obituary Notice of, 209
Flammario (M.), Saturn Apparently without Rings, 182
Fleas, Plague and, 59
Fleischmann (F. N. A.), Zeolites from the Neighbourhood of Belfast, 358
Fleming (Mrs.), Red Stars near Nova Velorum, 42; Stars having Peculiar Spectra, 158
Fleming (Dr. J. A.), Magnetic Oscillators as Radiators in Wireless Telegraphy, 71; Results obtained by the Ziegler Polar Expedition of 1903-5, 207
Fletcher (F.), the Wild and Cultivated Cotton Plants of the World, a Revision of the Genus *Gossypium*, Sir G. Watt, 241
Flett (Dr. J. S.), the Geology of the Land's End District, 90
Flexner (Dr. Simon), Tendencies in Pathology, 379
Flight, Stability in, A. Mallock, F.R.S., 293; Major B. Baden-Powell, 320; Herbert Chatley, 320
Flint Implements from Bungay, Small, W. A. Dutt, 102
Flora of Columbia, Missouri, and Vicinity, F. P. Daniels, 29
Flora, the Cretaceous, of Southern New York and New England, Arthur Hollick, 121
Flora of West Lancashire, the, J. A. Wheldon and A. A. Wilson, 194
Florida and West Indies, Sunshine and Sport in, F. G. Aflalo, 128
Flowers, on the Colouring Matters of, Dr. H. C. Sorby, F.R.S., 260
For. Atmospheric Electricity and, Dr. Charles Chree, F.R.S., 343
Foix (M.), Theory of the Radiation of the Auer Incandescent Gas Mantle, 420
Folklore: Cradle Tales of Hinduism, Margaret E. Noble, 605
Fonvielle (W. de), Histoire de la Navigation aérienne, 217
Food: the Preservation of Eggs, Fr. Prall, 84, 137; Considerations affecting the "Strength" of Wheat Flours, Julian L. Baker and H. F. E. Hulton, 598

- Forage Crops for Soiling, Silage, Hay, and Pasture, Dr. Edward B. Voorhees, 388
- Forcrand (M. de), Heat of Formation of the Anhydrous Oxides of Strontium and Barium, 359
- Forestry: Disease of the Pine in the Jura, MM. Prillieux and Maublanc, 23; E. Henry, 23; Worms and Tree-planting, E. A. Andrews, 205; The Garden Beautiful, Home-woods and Home Landscape, William Robinson, 217; R. I. Lynch, 300; Sucker Reproduction in Kistna District of Madras, A. W. Lushington, 256; Heredity and Forestry, Prof. W. Somerville, 279; Stages of Soil Denudation and Forest Destruction in the Tyrol, A. P. Young, 334; Fire Conservancy in Teak Forests, F. B. Bryant, 419; the Douglas Fir as a Commercial Timber Tree, J. D. Crozier, 419; Insects Injurious to Sal-forests of Assam, Mr. Stebbing, 587; New National Forest in Arizona, 614
- Forrest (H. E.), Distribution of the Pine-marten in England and Wales, 325
- Forster (M. O.), Action of Diazomethane on the Two Modifications of isoNitrosocamphor, 335; the Triazocouper, part II., Azoimides of Propionic Ester and of Methyl Ethyl Ketone, 431
- Foster (W. H.), Absorption Spectra of Collidine and o-Chlorocollidine, 190
- Fould (E.), Colloidal Properties of Starch and a Perfect Solution of this Substance, 383
- Foudrolements d'arbres, constatés en Belgique pendant les Années 1884-1906, Etude sur les, E. Vanderlinden, 197
- Fournier (G.), Saturn, a New Ring Suspected, 302
- Fox (J. J.), Colour and Constitution of Azo-compounds, part II., the Salts of β -Hydroxy-azo-compounds with Mineral Acids, 334
- Fox (Mr.), a Large Eruptive Prominence, 90
- Fox-Strangeways (C.), the Geology of the Leicestershire and South Derbyshire Coalfield, 364
- Foxworthy (F. W.), Commercial Philippine Woods, 399
- France: (1) Races bovine, France—Étranger, (2) Races chevalines, Prof. Paul Diffloth, 339
- Franco-British Exhibition of 1908, Science at the, 67
- Franco-British Exhibition, the Science Court of the, 609
- Franklin (W. S.), the Elements of Mechanics, 29
- Franklin (Prof. W. S.), Arrangement for Measuring the Resistance of Electrolytes without the Use of Electrodes, 89; the Elements of Electrical Engineering, 124
- Frazier (Dr. J. G.), Questions on the Customs, Beliefs, and Languages of Savages, Method of Use, 16; St. George and the Palilia, 327
- Freudenberger (L. A.), Arrangement for Measuring the Resistance of Electrolytes without the Use of Electrodes, 89
- Friswell (R. J.), the Production of Natural and Synthetic Indigo, 39
- Friswell (R. J.), Death and Obituary Notice of, 349
- Fritsch (Dr. F. E.), Algal Growth in Ceylon, 87
- Frog, Reissner's Fibre in the, George E. Nicholls, 344
- Frölich (Dr.), Ship Beri-beri and Scurvy, 113
- Frost (Prof.), the System of ζ Ursæ Majoris, 471; Spectroscopic Binaries now under Observation, 590
- Fuels, Liquid and Gaseous, and the Part they Play in Modern Power Production, Prof. V. B. Lewes, 98
- Fungi: Chemie der höheren Pilze, eine Monographie, Dr. Julius Zeller, Prof. R. Meldola, F.R.S., 553
- Furley (Kenneth G.), the Apple Sucker, Spraying Experiments, 180
- Gaillard (M.), Influence of Feeding on the Course of Experimental Tuberculosis, 95
- Gain (Edmond), a Peroxydiastase in Dried Seeds, 215; the Duration of the Peroxydiastases in Seeds, 479
- Gain (Gustave), an Isomeric Modification of Hydrated Hypovanadic Acid, 432
- Games of the North American Indians, the, Stewart Culin, Dr. A. C. Haddon, F.R.S., 568
- Garbasso (Prof. Antonio), Theory of the Mirage, 356
- Gardner (Prof. Walter M.), Dyeing in Germany and America, Sidney H. Higgins, 4
- Garrud (Sir Alfred B., F.R.S.), Death of, 203
- Garstang (Prof. J.), Burial Customs of Ancient Egypt, 439
- Gas, Town, and its Uses for the Production of Light, Heat and Motive Power, W. H. Y. Webber, 340
- Gases: die Zustandsgleichung der Gase und Flüssigkeiten und die Continuitätstheorie, Prof. J. P. Kuenen, 387
- Gaubert (Paul), Formation of Liquid Crystals of Two New Compounds of Cholesterin, 23; Artificial Reproduction of Heavy Spar, Celestine, and Anglesite, 96
- Gaunt (R.), Analysis of Indigo, 118
- Gautier (M.), the Transit of Mercury, November, 1907, 567
- Geddes (A. C.), Growth and Development of the Limbs of the Penguin, 407
- Gehrcke (Dr. F.), the Anode Rays, 89
- Gehrcke (Johan), the Sources of Supply of Atlantic Water to the North Sea, 400
- Geiger (Dr. H.), the Specific Heats of Helium, 257; Method of Counting the Number of α Particles from Radio-active Matter, 599
- Geisteslebens, die Mechanik des, Prof. Max Verworn, 556
- U Gemminor Type, a new Variable of the, Prof. Hartwig, 446
- Gemose (K. J.), Best Mode of determining the Age and Rate of Growth of Eels, 350
- Geodesy: General Report on the Survey of India during 1903-6, Colonel F. B. Longe, 470
- Geography: Death and Obituary Notice of Sir F. L. McClintock, K.C.B., F.R.S., 61; Geographical Boundaries, Miss E. C. Semple, 64; Obituary Notice of Prof. Angelo Heilprin, L. E. Levy, 136; Dr. Jean Charcot's Antarctic Expedition, 204; the Pulse of Asia: a Journey in Central Asia, illustrating the Geographic Basis of History, Ellsworth Huntington, Prof. Grenville A. J. Cole, 314; Land Erosion by Storm Water in Cape Colony, 351; Physiographical Experiments on the Aggrading and Degradating Stream, 351; Island in Vergangenheit und Gegenwart, Paul Herrman, 362; the Elements of Geography, J. H. N. Stephenson, 484; Atlas of the World's Commerce, 506; Problems of the Tropics, Prof. R. De C. Ward, 542; the Ziegler Polar Expedition, 1903-5, Anthony Fiala, Dr. C. Chree, F.R.S., 544; Physiography, Prof. R. D. Salisbury, Supp. to March 5, v
- Geology: a Description of the Soil-geology of Ireland, based upon Geological Survey Maps and Records, with Notes on Climate, J. R. Kilroe, 4; Winding of Rivers in Plains, Sir Oliver Lodge, F.R.S., 7, 79; R. D. Oldham, 55; R. C. Slater, 79; J. Y. Buchanan, F.R.S., 100; J. Lomas, 102; Dr. John Aitken, F.R.S., 127; Death and Obituary Notice of Sir James Hector, F.R.S., 37; de Vormen der Aardkorst, Insliding tot de Studie der Physiographie, J. van Baren, 76; Phosphatic Deposits near Dandaraga, W. D. Campbell, 88; the Geology of the Land's End District, Clement Reid, F.R.S., and Dr. J. S. Flett, 90; the Geology of the Country around Hungerford and Newbury, H. J. Osborne White, 90; Catalogue of the Type and Figured Specimens of Fossils, Minerals, Rocks, and Ores in the Department of Geology, U.S. Mus., J. P. Merrill, 91; Modern Lithology, Illustrated and Defined for the Use of University, Technical, and Civil-Service Students, E. H. Adye, 125; Obituary Notice of Prof. Angelo Heilprin, 156; Geological Society, 141, 165, 189, 214, 334, 358, 406, 454, 502, 527; Geological Society Medal Awards, 254; the Laurentian System of Canada, Prof. F. D. Adams, 142; Glacial Beds of Cambrian Age in South Australia, Rev. Walter Howchin, 165; H. Basedow and J. D. Illiffe, 165; Granite in the Diamond-bearing Chimney of De Beers, L. De Launay, 168; das inneralpine Becken der Umgebung von Wien, Dr. Franz X. Schaffer, 172; Geology of New Jersey, 181; Regent Work of Geological Surveys, 183; Pre-Glacial Raised Beach traced from Mumbles Head Westward, Mr. Tiddeman, 184; Geology of Islay, S. B. Wilkinson, 184; Geology of Country round Deutschbrod, Dr. Hinterlechner, 184; Glacial Deposits and Löss of Northern Galicia, Ritter von Lozinski, 184; Granite and Gneiss in Pre-Cambrian Complex of Fennoscandia, Mr. Sederholm, 184; Glacial Phenomena of Finmark, Mr. Tanner, 185; Geology of Eastern Desert of Egypt, Dr. W. F. Hume, 185; Geology of the Parapara Sub-division, New Zealand, J. M. Bell, 185; Geology of Baguio Mineral District, Manila, A. J. Eveland, 186; Faunal Succession in Carboniferous Limestone of Midland

- Area, T. F. Sibley, 189; Tertiary Limestones and Foraminiferal Tufts of Malekula, New Hebrides, F. Chapman, 192; Geographical Significance of Floods, with Especial Reference to Glacial Action, E. C. Andrews, 192; Records of the Geological Survey of India, Part iii., Notes on Certain Glaciers in North-west Kashmir, H. H. Hayden; Part iv., Glaciers in Lahaul, H. Walker and E. H. Pascoe; Glaciers in Kumaon, G. de P. Cotter and J. Caggin Brown, Prof. T. G. Bonney, F.R.S., 201; Recent Discoveries of Palaeolithic Implements, Sir John Evans, 214; a Deep Channel of Drift at Hitchin, W. Hill, 215; a Specific Gravity Balance for Large Rock Specimens, T. H. D. La Touche, 221; the Norton Goldfield, L. C. Ball, 257; the Annan River Tinfield, W. E. Cameron, 257; the Stanhills Tinfields near Croydon, B. Dunstan, 257; Geology of the Nandawar Mountains, New South Wales, H. I. Jensen, 264; the Geological Structure of the North-west Highlands of Scotland, B. N. Peach, John Horne, W. Gunn, C. T. Clough, L. Hinxman, and J. J. H. Teall, Prof. J. W. Gregory, F.R.S., 272; Chronology of the Glacial Epoch in North America, Prof. G. F. Wright, 334; Application of Quantitative Methods to the Study of the Structure and History of Rocks, Dr. H. C. Sorby, F.R.S., 334; Transvaal Mines Department, Report of the Geological Survey for the Year 1906, Dr. F. H. Hatch, 346; Origin of the Pillow-lava near Port Isaac in Cornwall, Clement Reid and Henry Dewey, 358; the Geology of the Leicestershire and South Derbyshire Coalfield, C. Fox-Strangeways, 364; the Shaping of Lindsey by the Trent, F. M. Burton, 371; Geological Survey of Canada, 380; the Cascade Coal Basin, Alberta, D. B. Dowling, 380; Kimberlite, J. P. Johnson, 399; Goldfields of Western Australia, C. G. Gibson, 400; Antigorite and the Val Antigorio, Prof. T. G. Bonney, 406; the St. David's Head "Rock Series," J. V. Elsdon, 406; a Description of the First or Aswan Cataract of the Nile, Dr. John Ball, 433; the Two Earth Movements of Colonsay, W. B. Wright, 454; Notes on the River Wey, H. Bury, 454; Glaciers of the Canadian Rockies and Selkirk (Smithsonian Expedition of 1904), Dr. William Hittell Sherzer, Prof. T. G. Bonney, F.R.S., 463; Scandinavian Glaciation, C. F. Kolderup, 468; Earthquakes, an Introduction to Seismic Geology, William Herbert Hobbs, 481; Shrinkage of Glaciers of Alberta and British Columbia, 495; Geology of the Country around Plymouth and Liskeard, Mr. Ussher, 495; Weathering, K. D. Glinka, 498; die Penultimations-theorie, Dr. Heinrich Simroth, 508; the Carboniferous Rocks at Loughshinny, Dr. C. A. Matley and Dr. A. Vaughan, 527; Petrology and Physiography of Western Liberia, Africa, J. Parkinson, 527; Geologische Prinzipienfragen, E. Reyer, Prof. Grenville A. J. Cole, 529; the High-level Platforms of Bodmin Moor and their Relation to the Deposits of Stream Tin and Wolfram, G. Barrow, 502; National Antarctic Expedition, 1901-4, Geology of South Victoria Land, H. T. Ferrar, Petrography, Dr. Prior, Prof. J. W. Gregory, F.R.S., 561; Origin and Mode of Deposit of the Upper Keuper Beds of Leicester, T. O. Bosworth, 587; Deviation of Rivers caused by the Rotational Velocity of the Earth, Prof. G. A. J. Cole, 612
- Geometrie: die typischen Geometrien und das Unendliche, B. Petronievics, 28; Constructions in Practical Geometry, Rev. H. F. Westlake, 148; Plane Geometry for Secondary Schools, C. Davison and C. H. Richards, 315; Cartesian Plane Geometry, Charlotte A. Scott, 315; a Sequel to Elementary Geometry, J. W. Russell, 315; a First Year's Course in Geometry and Physics, Ernest Young, 482
- Geophysics: Potentiometer Methods of Measuring Temperature, W. P. White, 206
- German Course, Science, C. W. P. Moffatt, 53
- Germany, Dying in, and America, Sidney H. Higgins, Prof. Walter M. Gardner, 4
- Geschlechtes, die Bestimmung und Vererbung des, Dr. C. Correns, 380
- Gesichtssinnes, zur vergleichenden Physiologie des, Prof. E. Raehlmann, 193
- (Giacobini), Search-ephemeris for Comet 1907a, Prof. Weiss, 138
- Giacobini (M.), the Giacobini Comet 1907a, 167
- Gibson (C. G.), Goldfields of Western Australia, 400
- Gibson (C. S.), Diethylauric Bromide, 94
- Gibson (Dr. G. A.), Arterial Pressure in Man, 335
- Giesenhagen (Prof. K.), Befruchtung und Vererbung im Pflanzenreiche, 556
- Giglioli (Enrico Hillyer), Avifauna Italica, 25
- Gilg (Dr. Ernst), Pharmakognostisches Praktikum, 508
- Giltay (J. W.), Apparatus for Demonstrating the Action of Light on Selenium, 589
- Gisevius (Prof. P.), das Werden und Vergehen der Pflanzen, 556
- Glaciers: Records of the Geological Survey of India, Part iii., Notes on Certain Glaciers in North-west Kashmir, H. H. Hayden; Part iv., Glaciers in Lahaul, H. Walker and E. H. Pascoe; Glaciers in Kumaon, G. de P. Cotter and J. Caggin Brown, Prof. T. G. Bonney, F.R.S., 201; Glaciers of the Canadian Rockies and Selkirks (Smithsonian Expedition of 1904), Dr. William Hittell Sherzer, Prof. T. G. Bonney, F.R.S., 463
- Gladstone (H. S.), Irish Nesting-colony of Red-necked Phalaropes, 63
- Glasgow, Lord Kelvin and the University of, 200
- Glass and Quartz, Coloration of, by Radium, Charles E. S. Phillips, 535
- Gleditsch (Mlle.), Lithium contained in Radio-active Minerals, 167, 497
- Glinka (K. D.), Weathering, 498
- Goddard (Rev. Ed. H.), Orientation of the Avebury Circles, 320
- Gods and Godlings, David Patrick, 462
- Goeldi (Dr. E. A.), Album de Aves Amazonicas, 220
- Gold (E.), Comparison of Ships' Barometer Readings with those deduced from Land Observations, 453
- Golding (H. A.), Practical Calculations for Engineers, 555
- Goldschmidt (Dr. Richard), die Tierwelt des Mikroskops (die Urtiere), 556
- Goldsmith (Dr. E.), Analysis of Meteoric Stone seen to Fall on April 30, 1906, on the New Jersey Shore, 136
- Goldstein (E.), the Two-fold Line Spectra of Chemical Elements, 469
- Gordon (W. T.), *Lepidophloios Scotti*, 431
- Gore (J. Ellard), Astronomical Essays, Historical and Descriptive, 195; Two Remarkable Spectroscopic Binaries, 520
- Gore (W.), Stresses in Masonry Dams, at Institution of Civil Engineers, 303
- Coris (A.), Researches on the Pulp called Nette' Flour, 336
- Gorscids, May, Rev. John Griffith, 128
- Goss (W. F. M.), High Steam-pressures in Locomotive Service, 445
- Göttingen Royal Society of Sciences, 72, 312, 479
- Gotz (P.), Surveys of Nebulae, 90
- Gough (Dr. L. H.), the Plankton of the English Channel, 524
- Gould (C.), the Geology and Water Resources of the Western Portion of the Panhandle of Texas, 68
- Goulding (E.), New Isomerie of Vanillin in the Root of *Clorocodon*, 502; Volatile Oils of the Leaves of *Ocimum viride*, 502
- Goupil (M.), Physiological Properties of Tubercle Bacilli which have been Submitted to the Action of Chlorine, 216
- Gewland (Prof.), Burial Mounds in Japan, 139
- Graff (Dr. K.), Observations of Algal Variables, 497
- Graff (Prof. Ludwig von), das Schmarotzertum im Tierreich und seine Bedeutung für die Artbildung, 556
- Gramont (A. de), Apparatus for the Production of Spark Spectra of Solutions, 168
- Graphical Interpolation, F. J. W. Whipple, 103
- Gravitational-Survey of Sicily and Calabria, Prof. Ricco, 232
- Gray (J.), New Instrument for determining the Colour of the Hair, Eyes, and Skin, 400
- Gray (J. G.), Sensitive State induced in Magnetic Materials by Thermal Treatment, 407
- Gray (J. Macfarlane), Death and Obituary Notice of, 277
- Greaves (R. H.), Decomposition of Ozone by Heat, 574
- Greece and Rome, Malaria, a Neglected Factor in the History of, W. H. S. Jones, 457
- Green (A. G.), Constitution of Phenol- and Quinol-phthalein Salts, 47

- Greene (H. B.), Influence of Heredity on the Diseases of Poultry, 15
- Greenwich Winters, Rothesay Summers and, Alex. B. MacDowall, 438
- Greenwood (M., jun.), Influence of Increased Barometric Pressure on Man, 187
- Gregory (A. W.), Calorimetric Method for the Determination of Iron in Copper Alloys, 239
- Gregory (Prof. J. W., F.R.S.), Origin of the Gold in the Rand Banket, 22; the Geological Structure of the North-west Highlands of Scotland, B. N. Peach, John Horne, W. Gunn, C. T. Clough, L. Hinxman, and J. J. H. Teall, 272; National Antarctic Expedition, 1901-4, Geology of South Victoria Land, H. T. Ferrar, Petrography, Dr. Prior, 561
- Griffin and Sons (Messrs.), New Slide-rules, 500
- Gilfith (Rev. John), May Gorseeds, 128
- Grignard (O.), New Method for the Hydration of Pinene, 240
- Groom (Prof. P.), Trees and their Life-histories, 538
- Grover (N. C.), River Discharge, 148
- Groves (C. E.), Cobaltamine Compounds, 239
- Gruener (Prof.), the World of the Infinitely Small, 543
- Gudernatsch (J. F.), Resemblances between the Sirenian and the Cetacean Tongue, 350
- Guerbet (Marcel), Action of Alcohols upon Sodium Benzylate, 384
- Guichard (Marcel), Preparation of Iodides *in vacuo*, 95; Tetra-iodide of Uranium, 119
- Guignard (L.), Grating in Plants containing Hydrocyanic Acid, 239
- Guillaume (Ch.-Ed.), les Récents Progrès du Système métrique, 611
- Guillemard (H.), Influence of High Altitude on the Loss of Water by the Organism, 95
- Gillet (L.), Constitution of Cast Irons containing Manganese, 288
- Guilliermond (A.), Structure of the Aleurone Grains in Graminaceæ, 48
- Gulliver (G. H.), Phenomena of Permanent Deformation of Metals, 41
- Gunn (W.), the Geological Structure of the North-west Highlands of Scotland, 272
- Gurney (L. E.), the Viscosity of Water at Very Low Rates of Shear, 470
- Gustavson (G.), Products of the Action of Aluminium Chloride and Hydrochloric Acid Gas on Benzene, 527
- Guthnick (Paul), Saturn's Rings, 67
- Guthrie (F. B.), Action of Lime on the Available Soil Constituents, 23
- Gwynne-Vaughan (D. T.), Fossil Osmundaceæ, 311
- Gyroscope illustrating Brennan's Mono-railway, Prof. H. A. Wilson, 189
- Gyrostats, the Use of, Prof. J. Perry, F.R.S., at Physical Society, 447
- Haddon (Dr. A. C., F.R.S.), Obituary Notice of Dr. A. W. Howitt, C.M.G., 515; the Games of the North American Indians, Stewart Culin, 568
- Haffkine (Dr.), Present Methods of combating Plague, 133
- Hagen (Allen), Clean Water and How to Get It, 218
- Hahn (Dr. Otto), the Origin of Radium, 30
- Haines (C. Reginald), Notes on the Birds of Rutland, 122
- Hall (Dr. Asaph), Death of, 132; Obituary Notice of, 154
- Hall (Clarence), the Waste of Life in American Coal-mining, 419
- Hall (Edith H.), Decorative Art of Crete in the Bronze Age, 186
- Hall (H. R.), the Annual of the British School at Athens, 129; Archaeology in America, 186; Burial Customs of Ancient Egypt, Prof. J. Garstang, 439
- Hall (Maxwell), Jamaica Earthquake of January 2, 1908, 542
- Haller (A.), an Isomer of Diphenylcamphomethane, 575; Alcoholysis of Linsseed Oil, 383
- Halley's Comet, the Meteors of, W. F. Denning, 619
- Hollburton (Prof. W. D., F.R.S.), Chemische und biologische Untersuchungen von ägyptischen Mumienmaterial, nebst Betrachtungen über das Einbalsamierungsverfahren, der alter Ägypter, —W. A. Schmidt, 465; Localisation of Function in the Lemur's Brain, 501
- Hallucinations, New Explanation of, Dr. Boris Sais, 589
- Ham (B. Burnett), Report on Plague in Queensland (February, 1900—June 30, 1907), 585
- Hamburg: die Fauna Südwest-Australiens, Ergebnisse der Hamburger südwest-australischen Forschungsreise, 1905, Prof. W. Michaelson and Dr. R. Hartmeyer, 51; the Hamburg Observatory, Prof. Schorr, 544
- Hamilton (N. D.), the Weathering of Coal, 468
- Hampson (Rev. John J.), Stock Frost or Ground Ice, 295
- Hansch (Prof.), Structure of the Corona, 590
- Hantsch (A.), the Cryoscopic Behaviour of Sulphuric Acid, 207
- Harbord (F. W.), the Phenomenon of Soft Steel Disc Revolving at a High Speed Cutting Hard Steel, 419
- Harg (J. M.), Recent Observations of Venus, 471
- Harger (H. S.), the Diamond Pipes and Fissures of South Africa, 224
- Harkins (W. D.), the Smoke from Metallurgical Works, 376
- Harley (Rev. Robert, F.R.S.), Biographical Sketch of Robert Rawson, 157
- Harper (W. E.), the Orbit of the Spectroscopic Binary θ Aquilæ, 281; Variable Radial Velocity of η Virginis, 590
- Hartley (H.), Preparation of Conductivity Water, 431; Solubility of Iodine in Water, 502; Spontaneous Crystallisation of Sodium Sulphate Solutions, 551
- Hartmann (Prof.), the Recent Spectrum and Magnitude of Nova Persei No. 2, 377; Spectroscopic Binaries now under Observation, 590
- Hartmeyer (Dr. R.), die Fauna Südwest-Australiens, Ergebnisse der Hanburger südwest-australischen Forschungsreise, 1905, 51
- Hartwig (Prof.), Saturn's Rings, 67; a New Variable of the U Geminorum Type, 446; the Variable Star 31, 1907, Aurigæ, 471
- Harvard College Observatory, the, Prof. Pickering, 567
- Haschek (Dr. E.), Cause of the Slight Variability of Wavelength of Spectral Lines, 304
- Hassenstein (Dr.), Saturn's Ring, 90
- Hatch (Dr. F. H.), "Kimberlite" and the Source of the Diamond in South Africa, 224; Mining Tables, 317; Transvaal Mines Department, Report of the Geological Survey for the Year 1906, 346
- Hatfield (W. H.), the Evolution of Malleable Cast Iron, 543
- Hatta (S.), Gastrulation of the Ovum of the Lamprey, 179
- Hawaiian Islands and Laysan, Recent Madrepোরিয়া of the, T. Wayland Vaughan, Prof. S. J. Hickson, F.R.S., 499
- Hawkins (C.), Elementary Trigonometry, 315
- Hayden (H. H.), Notes on Certain Glaciers in North-west Kashmir, 201
- Health: the Laws of Health, a Handbook on School Hygiene, Dr. Carstairs G. Douglas, 197; the Preservation of Infant Life, a Guide for Health Visitors, Emilia Kanthack, 268
- Heat: Measurement of Temperatures in the Cylinder of a Gas Engine, Prof. Callendar, F.R.S., and Prof. W. E. Dalby, 141; Simple Calorimeter for Gases and Liquids, Charles Féry, 182; Manganese Chloride as Fixed Point in Thermometry, T. W. Richards and Franz Wrede, 207; the Cryoscopic Behaviour of Sulphuric Acid, A. Hantsch, 207; Influence of Temperature on the Optical Properties of Dissolved Bodies, C. Chêneveau, 216; Variation of the Electrical Resistance of Pure Metals Down to Very Low Temperatures, Prof. H. Kamerlingh Onnes and J. Clay, 233; the Specific Heats of Helium, Drs. U. Behn and H. Geiger, 257; Effect of Low Temperatures on the Thermal Conductivities of Pure Metals and Alloys, Prof. C. H. Lees, F.R.S., 287; Sensitive State induced in Magnetic Materials by Thermal Treatment, J. G. Gray and A. D. Ross, 407; Heat of Vaporisation of Propionic Acid, A. Faucon, 455; Notes on the Application of Low Temperatures to Some Chemical Problems, Sir James Dewar and Dr. H. O. Jones, 476; Action of Alkaline Salts with Fixed Base on the Combustion of Gases and Fixed Combustibles, M. Dautriche, 479; the New Matriculation Heat, 482; Determination of Viscosity at High Temperatures, Dr. C. E. Fawsitt, 502; Certain Dynamical Analogues of Temperature Equilibrium, Prof. G. H. Bryan, 503; Decomposition

- of Ozone by Heat, Prof. E. P. Perman and R. H. Greaves, 574
- Heather (H. J. S.), Electrical Equipment of Gold Mines, 575
- Heavenly Bodies, Peculiarities in the Structure of some, Prof. Suess, 490
- Hector (Sir James, F.R.S.), Death and Obituary Notice of, 37
- Hedrick (H. B.), a Catalogue of Zodiacal Stars, 533
- Heilprin (Prof. Angelo), Obituary Notice of, L. E. Levy, 130
- Heinrich (V.), Elements and Ephemeris for the Minor Planet Patroclus, 67
- Helium in the Atmosphere, Dr. J. W. Evans, 535
- Helium, the Condensation of, Prof. H. Kamerlingh Onnes, 559, 581; Dr. Morris W. Travers, F.R.S., 606; the Solidification of, Prof. Alfred W. Porter, 437; Dr. H. Kamerlingh Onnes, 442
- Helium Line, D₁, as a Dark Line in the Solar Spectrum, the, A. A. Buss, 377
- Helium, D₂ Line in the Solar Spectrum, Capt. Daunt, 520
- Hellmann (Dr. G.), the Dawn of Meteorology, 478
- Helmert (F. R.), das Ausgleichsrechnung nach der Methode der kleinsten Quadrate, 52
- Hemmelmayer (Franz von), Lehrbuch der Chemie und Mineralogie für die vierte Klasse der Realschulen, 484
- Hemseleh (Dr. G. A.), Flame Spectra obtained by the Electrical Method, 215; the Flame Spectra of Metals, 446; Flame Spectra of Iron, 623
- Henry (E.), Disease of the Pine in the Jura, 23
- Henry (John R.), November Meteors, 31; April Meteors, 535
- Henry (Louis), the Nitrous Isomerisation of Isobutyl Alcohol, 119; Action of Nitrous Acid on Allylamine, 215
- Henry (T. A.), Occurrence of Cyanogenetic Glucosides in Feeding Stuffs, 598
- Henshaw (F.), the Water Supply of Nome Region, Seward Peninsula, 68
- Henshaw (H. W.), "the Policemen of the Air," 493
- Henslow (Rev. G.), Origin of the Ditrimerous Floral Whorls of Certain Dicotyledons, 142
- Hepworth (Commander M. W. Campbell, C.B.), Notes on Maritime Meteorology, 126
- Heredity: the Interpretation of Mendelian Phenomena, Geo. P. Mudge, 8; G. Archdall Reid, 9, 54; R. H. Lock, 32; J. T. Cunningham, 54; H. H. O'Farrell, 271; Mendelism and Sex, G. Archdall Reid at Linnean Society, 236; Mendelian Characters among Shorthorns, Prof. James Wilson, 509, 559; Prof. Karl Pearson, F.R.S., 559; Prof. John G. McKendrick, F.R.S., 582; Specific Stability and Mutation, Sir W. T. Thistelton-Dyer, K.C.M.G., F.R.S., 77, 127; R. H. Lock, 127; Mylattis, Sir W. T. Thistelton-Dyer, K.C.M.G., F.R.S., 126; H. G. Wells, 149; sur la Transmissibilité de Caractères acquis, Eugenio Rignano, 193; the Inheritance of "Acquired" Characters, Rev. E. C. Spicer, 247, 342; Dr. G. Archdall Reid, 293, 342, 391; A. D. D., 343; J. F. Cunningham, 367; Dr. H. Charlton Bastian, F.R.S., 319, 399; the Melanic Variety of the "Peppered Moth," A. Baco, 294; Heredity and Environic Forces, Dr. MacDougal, 378; the Mechanism in Heredity, Dr. E. G. Conklin, 378; the Inheritance of Eye-colour in Man, C. G. Hurst, 382; the Inheritance of Colour in Domestic Pigeons with Special Reference to Reversion, R. Staples-Browne, 430; Befruchtung und Vererbung im Pflanzenreich, Prof. K. Giesenhagen, 556; die Bestimmung und Vererbung des Geschlechtes, Dr. C. Correns, 580
- Hérissey (H.), the Preparation of Dithymol, 584
- Herman (I.), Syntheses by Means of the Mixed Organometallic Derivatives of Zinc, Ketone Alcohols, 455
- Heron (David), Statistics of Insanity and Inheritance of Insane Diathesis, 179
- Herpitology of Japan and Adjacent Territory, L. Stejneger, 91
- Herrera (Prof. A. L.), Notions générales de Biologie et de Plasmogénie, 558; Chrysanthemum Powder as a Means of destroying Mosquitoes in Houses, 278
- Herring (Dr. Percy T.), a Manual of Veterinary Physiology, Colonel F. Smith, C.B., C.M.G., 210
- Herrman (Paul), Island in Vergangenheit und Gegenwart, 362
- Herrmann (Dr. E.), the Periodical Variations of Atmospheric Pressure, 157
- Herschel's Nebule, the, Dorothea Isaac-Roberts, 617
- Hessler (Dr. Robert), Malaria and Tuberculosis introduced into America by the White Man, 231
- Hewitt (J. F.), Primitive Traditional History: the Primitive History and Chronology of India, South-eastern and South-western Asia, Egypt, and Europe, and the Colonies Thence sent Forth, 291
- Hewitt (J. T.), Colour and Constitution of Azo-compounds, Part ii, the Salts of *p*-Hydroxy-azo-compounds with Mineral Acids, 334
- Hewlett (Prof. R. T.), die Purpurbakterien, Prof. Hans Molisch, 53; Inflammation, an Introduction to the Study of Pathology, Prof. J. George Adams, 126; Scientific Work of the Local Government Board, 235; the Bacteriological Examination of Disinfectants, W. Partridge, 246; Abel's Laboratory Handbook of Bacteriology, 580; Lehrbuch der mikroskopischen Technik, Dr. Bernhard Rawitz, 605
- Hickson (Prof. S. J., F.R.S.), Recent Madreporaria of the Hawaiian Islands and Laysan, T. Wayland Vaughan, 499
- Higgins (Sidney H.), Dyeing in Germany and America, 4
- Hilburgh (Dr. W. L.), Sinhalese Magic, 551
- Hildebrandt (A.), Airships Past and Present, together with Chapters on the Use of Balloons in Connection with Meteorology, Photography, and the Carrier Pigeon, 562
- Hilditch (T. P.), Relation between Unsaturation and Optical Activity, 166
- Hill (J. R.), Replacement of Alkyl Radicles by Methyl in Substituted Ammonium Compounds, 166
- Hill (Leonard, F.R.S.), Influence of Increased Barometric Pressure on Man, 187
- Hill (M. D.), a Variation in Amœba, 367
- Hil (W.), a Deep Channel of Drift at Hitchin, 215
- Himalayan Glaciers, Fluctuations in, Prof. T. G. Bonney, F.R.S., 201
- Himalayas, Ascent of Trisul, 134
- Hind (Dr. Wheelton), Lamellibranch Fauna in the Millstone Grit of Scotland and the Silurian Rocks of Girvan, 551
- Hinduism, Cradle Tales of, Margaret E. Noble, 605
- Hinterlechner (Dr.), Geology of Country Round Deutschland, 184
- Hinsman (L.), the Geological Structure of the North-west Highlands of Scotland, 272
- Hirayama (K.), the Systematic Error of Latitude observed with a Zenith Telescope, 42
- Histoire de la Navigation aérienne, W. de Fonvielle, 217
- History: Primitive Traditional, the Primitive History and Chronology of India, South-eastern and South-western Asia, Egypt and Europe, and the Colonies Thence sent Forth, J. F. Hewitt, 291
- Hobart (H. M.), Armature Construction, 532
- Hobbs (William Herbert), Earthquakes, an Introduction to Seismic Geology, 481
- Hoche (Prof. A.), the Modern Analysis of Psychological Phenomena, 469
- Hoernle (Dr. A. F. Rudolf, C.I.E.), Studies in the Medicine of Ancient India, 533
- Holetschek (Dr. J.), Observations of Comets 1907d and 1907e, 353
- Holland (T. H., F.R.S.), Mineral Production of India during 1906, 400
- Holland (Mr.), Molasses as Cattle Food, 500-1
- Holliek (Arthur), the Cretaceous Flora of Southern New York and New England, 121
- Hollis (Dr. W. Ainslie), the Possibility of Life in Mars, 438
- Holloway (G. T.), the Assay of Telluride Ores, 190
- Holmes (Mr.), the Appearance of Neptune in Small Telescopes, 258
- Holmes (H.), Action of Diazomethane on the Two Modifications of *iso*Nitrosocamphor, 335
- Holmes (Dr. T. Rice), Ancient Britain and the Invasions of Julius Caesar, 601
- Holst (Prof.), Ship Beri-beri and Scurvy, 113
- Holt (E. W. L.), Reports on the Sea and Inland Fisheries of Ireland for 1904 and 1905, 373
- Holt (J. C.), the Water Supply of Nome Region, Seward Peninsula, 68
- Holtmann (Dr. Carl), der Einfluss des Klimas auf den

- Bau der Pflanzengewebe, anatomisch-physiologische Untersuchungen in den Tropen, 313
- Home-woods and Home Landscape, the Garden Beautiful, William Robinson, 217; R. I. Lynch, 300
- Hooton (W. M.), Decomposition of Ammonium Dichromate by Heat, 383
- Hopkinson (Prof. Bertram), Effect of Mixture Strength and Scavenging upon Thermal Efficiency, 588
- Horizon and Prime-vertical Curves for Latitudes $+30^\circ$ to $+60^\circ$, H. H. Kritzinger, 617
- Horne (John), the Geological Structure of the North-west Highlands of Scotland, 272
- Horses: the Surgical Anatomy of the Horse, John T. Share-Jones, 170; Races chevalines, Prof. Paul Dillhoff, 339
- Horsley (Sir Victor, F.R.S.), Alcohol and the Human Body, 386
- Horticulture, the Apple Sucker, Spraying Experiments, Kenneth G. Furley, 180; the Journal of the South-eastern Agricultural College, Wye, Kent, 345
- Horton (F.), Spectrum of the Discharge from a Glowing Lime Kathode in Mercury Vapour, 454
- Horton (R. E.), Weir Experiments, Coefficients and Formulas, 68
- Hossack (Dr. W. C.), Rats and Plague in India, 205
- Housseu (Dr. C.), Vegetation on Doi Sutap, Siam, 588
- Howchin (Rev. Walter), Glacial Beds of Cambrian Age in South Australia, 165
- Howe (M. A.), Symmetrical Masonry Arches, 507
- Howitt (Dr. A. W.), Literature relating to the Australian Aborigines, 80
- Howitt (Dr. A. W., C.M.G.), Death of, 443; Obituary Notice of, Dr. A. C. Haddon, F.R.S., 515
- Howlett (Rev. F.), Death of, 349
- Hoyt (J. C.), River Discharge, 148
- Hubbard (Dr. Arthur John, and George), Neolithic Depositions and Cattle-ways, 245
- Hubner (J.), the Characterisation of Mercerised Cotton, 239; New Reactions for the Characterisation of Mercerised Cotton, 359
- Hue (E.), Musée ostéologique; Étude de la Faune Quaternaire, Ostéométrie des Mammifères, 604
- Hulbert (H. H.), Voice Training in Speech and Song, 317
- Hulton (H. F. E.), Considerations affecting the "Strength" of Wheat Flours, 598
- Human Body, Alcohol and the, Sir Victor Horsley, F.R.S., and Dr. Mary D. Sturge and Dr. Arthur Newsholme, 387
- Hume (Dr. W. F.), Geology of Eastern Desert of Egypt, 185
- Humphreys (H. B.), Physiology and Morphology of Californian Hepatics, 445
- Iiuntington (Ellsworth), the Pulse of Asia: a Journey in Central Asia illustrating the Geographic Basis of History, 314
- Hurst (C. C.), the Inheritance of Eye-colour in Man, 382
- Hutchinson (G. A.), Spontaneous Crystallisation of Sodium Sulphate Solutions, 551
- Huxley (T. H.), Aphorisms and Reflections, 341
- Hydraulics; Influence of the Thickness of the Pipe Wall on the Rate of Discharge of Water from Minute Orifices piercing the Pipe, W. R. Baldwin-Wiseman, 231; Hydraulics, F. C. Lea, 530
- Hydrography: the Bed of the Western Pacific Ocean, 21; River Discharge, J. C. Hoyt and N. C. Grover, 148; Tidal Investigations in Canada, W. Bell Dawson, 202; the Sources of Supply of Atlantic Water to the North Sea, Johan Gehrke, 400
- Hydrology: Hydrology in Egypt, Captain H. G. Lyons, 21; Hydrology in the United States, 68, 404; Pollution of the Illinois and Mississippi Rivers by Chicago Sewage, Marshall O. Leighton, 68; the Geology and Water Resources of the Western Portion of the Panhandle of Texas, C. Gould, 68; the Water Supply of Nome Region, Seward Peninsula, J. C. Holt and F. Henshaw, 68; Underground Waters of the Coastal Plain of Texas, T. U. Taylor, 68; Potomac River Basin, Messrs. Parker, Willis, Bolster, and Marsh, 68; the Quality of Surface Waters in Minnesota, Mr. Wesbraat, 68; Weir Experiments, Coefficients, and Formulas, R. E. Horton, 68; Clean Water and How to Get It, Allen Hagen, 218
- Hygiene: the Care of the Body, Dr. Francis Cavanagh, 5; School Hygiene, a Handbook for Teachers of all Grades, School Managers, &c., Herbert Jones, 99; the Habits, Life-history, and Breeding-places of the House-fly, R. Newstead, 135; Decomposition and Nitrification of Sewage (1) in Alkaline Solution, (2) in Distilled Water, J. E. Purvis and R. M. Courtald, 190-1; Nature's Hygiene and Sanitary Chemistry, C. T. Kingzett, 196; the Laws of Health, a Handbook on School Hygiene, Dr. Carstairs G. Douglas, 197
- Hygroscope, an Extremely Sensitive Electric, J. Pionchon, 600
- Ibbetson (Sir Denzil), Death and Obituary Notice of, 443
- Icc, Stock Frost or Ground, Rev. John J. Hampson, 295; James Thomson, 366; Prof. H. T. Barnes, 412
- Ice-crystals, Drifted, Dr. Walter Leaf, 271
- Ice-making from Pure Water in Winter, Method of, H. Warth, 518
- Iceland: Island in Vergangenheit und Gegenwart, Paul Herrman, 362
- Ichinoe (Naozo), the Maximum of Mira, 1906, 158
- Ichthyology: Zoology of Egypt, the Fishes of the Nile, G. A. Boulenger, F.R.S., 10; Two Luminous Fishes from Malay Archipelago, Dr. Steche, 15; Parasites of Bermuda Fishes, Edward Linton, 87; the Life of the Salmon, with Reference more Especially to the Fish in Scotland, W. L. Calderwood, 173; Gastrulation of the Ovum of the Lamprey, S. Hatta, 179; Erythrolytic Function of the Spleen in Fishes, Richard Blumenthal, 336; *Rhynchobdella aculeata* in Ceylon, Dr. Arthur Willey, F.R.S., 345; Best Mode of Determining the Age and Rate of Growth of Eels, K. J. Gensøe, 350; a Possible Case of Mimicry in the Common Sole, Dr. A. T. Masterman, 477; Age and Growth-rate of Plaice in the Southern North Sea determined by the Otolith, Dr. Wallace, 523; the Food of Fishes, R. A. Todd, 524; Structure of the Epidermis and Epidermal Glands of Poisonous Fishes, E. Pawlowsky, 613
- Iliffe (J. D.), Glacial Beds of Cambrian Age in South Australia, 165
- Illusion, an Optical, Dr. L. U. H. C. Wernldy, 31
- Imms (A. D.), Bee's "Paralysis," 62
- Immune Sera, Dr. C. F. Bolduan, 411
- Immunity to Disease among Plants, Prof. F. E. Weiss, at British Pharmaceutical Conference at Manchester, 20
- Inanition, the Influence of, on Metabolism, Francis Gano Benedict, 610
- Ince (Dr. W. H.), Chemical Examination of West Australian Poison Plants, 180
- Index of Archeological Papers, 557
- India: the Victoria Jubilee Technical Institute, Bombay, Dr. Morris W. Travers, 31; Records of the Geological Survey of India, Part iii., Notes on Certain Glaciers in North-west Kashmir, H. H. Hayden, Part iv., Glaciers in Lahaul; H. Walker and E. H. Pascoe; Glaciers in Kumaon, G. de P. Cotter and J. Caggin Brown, Prof. T. G. Bonney, F.R.S., 201; Education and Research in India, 202; Agricultural Statistics of India, 208; Plagues and Pleasures of Life in Bengal, Lieut.-Colonel D. D. Cunningham, 223; Sucker Reproduction in Kistna District of Madras, A. W. Lushington, 256; Notes on Indian Mathematics—Arithmetical Notation, R. Kaye, 347; Memoirs of the Indian Meteorological Department, being Occasional Discussions and Compilations of Meteorological Data relating to India and Neighbouring Countries, Vol. xviii., Part iii., V., a Discussion of the Anemographic Observations recorded at Allahabad from September, 1890, to August, 1904; VI., a Discussion of the Anemographic Observations recorded at Lucknow from June, 1878, to October, 1892, Sir John Eliot, K.C.I.E., F.R.S., 323; Meteorology of October and November, 1007, 419; Studies in the Medicine of Ancient India, Dr. A. F. Rudolf Hoernle, C.I.E., 533; Reports on Plague Investigations in India issued by the Advisory Committee appointed by the Secretary of State for India, the Royal Society and the Lister Institute, 588; the Etiology and Epidemiology of Plague, Major G. Lamb, 585
- India-rubber and its Manufacture; with Chapters on Gutta-percha and Balata, Hubert L. Terry, C. Simmonds, 296

- Inductance in Parallel Wires, Dr. J. W. Nicholson, 295
- Industry, Science and, 621
- Infant Life, the Preservation of, a Guide for Health Visitors, Emilia Kanthack, 268
- Infants, Relations' between Mortality of, and, High Temperatures, Dr. E. Van Everdingen, 206
- Inflammation, an Introduction to the Study of Pathology, Prof. J. George Adami, Prof. R. T. Hewlett, 126
- Inorganic Chemistry, a New Handbook of, 25
- Inorganic Chemistry, E. J. Lewis, 364
- Insanity, Statistics of, and Inheritance of Insane Diathesis, David Heron, 179
- Insects: Précis des Caractères générales des Insectes, disposés dans un Ordre naturel par le Citoyen Latreille, 77; the Story of Insect Life, W. P. Westell, Fred. V. Theobald, 175
- Institution of Civil Engineers, Awards for 1906-7, 14; Inaugural Address at, Sir William Matthews, K.C.M.G., 14; Experiments on Wind-pressure, Dr. T. E. Stanton, 139; Stresses in Masonry Dams, Sir John Ottley, K.C.I.E., and Dr. A. W. Brightmore, J. S. Wilson and W. Gore, 303; "James Forrester" Lecture at, Some Unsolved Problems in Metal-mining, Prof. Henry Louis, 619
- Institution of Engineers and Shipbuilders in Scotland, the Place of the Laboratory in the Training of Engineers, Prof. A. L. Mellanby, 211
- Institution of Mining and Metallurgy, 22, 119, 190, 287, 406, 575
- Instruction, the Practice of, 243
- Insulator, Sulphur as an, Rev. F. J. Jervis-Smith, F.R.S., 149
- Integrals, Tabulated Values of Certain, C. E. Adams, 462, Harry M. Elder, 486
- Intensity of Spectrum Lines, A. D. Cowper, 248
- International Association of Seismology, the, 60
- International Conference on Sleeping Sickness, Proceedings of the, held at London, June, 1907, 400
- International Mathematical Congress at Rome, the, Prof. G. H. Bryan, F.R.S., 582
- Interpretation of Mendelian Phenomena, the, Geo. P. Mudge, 8; G. Archdall Reid, 9, 54; R. H. Lock, 32; J. T. Cunningham, 54; H. H. O'Farrell, 271
- Interstellar Space, the Dispersion of Light in, Dr. C. Nordmann, 497
- Ionisation of Air by Ultra-violet Light, Frederic Palmer, jun., 582
- Ireland: a Description of the Soil-geology of Ireland, based upon Geological Survey Maps and Records, with Notes on Climate, J. R. Kilroe, 4; Royal Irish Academy, 239; Reports on the Sea and Inland Fisheries of Ireland for 1904 and 1905, E. W. L. Holt, 373
- Iron and Steel, J. H. Stansbie, 579
- Iron and Steel, the Corrosion of, Dr. Frank Clowes, 560
- Ironclads, a Contribution to the History of, Lord Rosse, 356
- Irvine (J. C.), Derivatives of Tetramethyl Glucose, 239
- Isaac-Roberts (Dorothea), the Herschel's Nebula, 617
- Isothermal Layer of the Atmosphere, the, W. H. Dines, F.R.S., 590, 462, 486; Dr. Charles Chree, F.R.S., 437; C. E. Stroneyer, 485
- Itasca Avifauna, Enrico Hillyer Giglioli, 25
- Iterica (Dr. G. van, jun.), Mathematische und mikroskopisch-anatomische Studien über Blattstellungen, 145
- Jackson (C. G.), Influence of Foreign Substances on Certain Transition Temperatures and the Determination of Molecular Weights, 383
- Jackson (C. S.), a First Statics, 555
- Jaeger (F. M.), Crystal Form of Halogen Derivatives of Open Chain Hydrocarbons with Reference to the Barlow-Pope Theory of Structure, 383
- James (George W.), the Story of Scraggles (a Sparrow), 77
- Janczewski (Prof. E. De), the Genus Ribes, 135
- Janssen (Dr. P. J. C.), Death of, 178; Obituary Notice of, 220
- Jantsch (A.), the Atomic Weight of Europium, 455
- Jantsch (G.), Compounds of Terbium and Dysprosium, 311
- Javillier (M.), Fixation of Zinc by *Sterigmatocystis nigra*, 408
- Japan, Herpetology of, and Adjacent Territory, L. Stejneger, 91
- Javelle (M.), the Recent Transit of Mercury, 116; the Giacobini Comet, 107a, 167
- Javillier (Maurice), Method for estimating Very Small Quantities of Zinc, 119
- Jeannel (René), Palaeolithic Paintings of Man and Animals in the Portal Cave, 528
- Jensen (H. I.), Copper in Andesite from Fiji, 23; Geology of the Nandewar Mountains, New South Wales, 264
- Jensen (Dr. Paul), Organische Zweckmässigkeit Entwicklung und Vererbung von Standpunkte der Physiologie, 100
- Jervis-Smith (Rev. F. J., F.R.S.), Sulphur as an Insulator, 149
- Jesup (Morris K.), Death of, 298
- Johansen (A. C.), Marking and Transplantation Experiments with Plaice in Danish Waters, 418
- Johnson (G.), the Separation of Tin-oxide from Wolfram, 119
- Johnson (J. P.), Eruptive Diamond-bearing Breccias of the Boshof District, 287; Kimberlite, 399
- Johnson (Prof. T.), *Spongospora Solani*, Brunch., 455
- Johnson (Prof. Willis G.), Death of, 541
- Johnston (Sir H. H., G.C.M.G.), aus Namaland und Kalahari, Prof. Leonhard Schultz, 385
- Johnston (Prof. J. B.), the Nervous System of Vertebrates, 73
- Joly (Prof. J.), Radio-activity of Sea Water, 191; Radium Content of Deep-sea Sediments, 455
- Jonckheere (Robert), Measurements of the Diameters of Mercury, 431
- Jones (B. M.), Spontaneous Crystallisation of Sodium Sulphate Solutions, 551
- Jones (F.), Action of Selenium and Tellurium on Arsine and Stibine, 590
- Jones (Harry C.), Conductivity and Viscosity in Mixed Solvents, 213
- Jones (Herbert), School Hygiene: a Handbook for Teachers of all Grades, School Managers, &c., 99
- Jones (Dr. H. O.), Replacement of Alkyl Radicles by Methyl in Substituted Ammonium Compounds, 166; Notes on the Application of Low Temperatures to some Chemical Problems, 476
- Jones (H. Sydney), a Modern Arithmetic, with Graphic and Practical Exercises, 27
- Jones (W. H. S.), Malaria, a Neglected Factor in the History of Greece and Rome, 457
- Jordan (David Starr), Evolution and Animal Life, 242; (1) California and the Californians, (2) the Alps of King-Kern Divide, 437
- Jordan (F. C.), Absolute Scale of Photographic Magnitudes, 208
- Jost (Prof. Ludwig), Lectures on Plant Physiology, 97
- Journal of the South-eastern Agricultural College, Wye, Kent, 345
- Jubilee of the Calcutta University, 584
- Judet (Henri), Attempt at Grafting Articular Tissues, 336
- Jupiter: the Great Red Spot on Jupiter, Mr. Denning, 42; Photographs of Jupiter, M. Quénefen, 90; Photographs of Jupiter's Satellites VI. and VII., 137; Simultaneous Observations of Jupiter, Jean Mascart, 259; Uniformly Distributed Dark Spots on Jupiter, Scriven Bolton, 401; a Possible New Satellite to Jupiter, P. Melotte, 470; Observations of Jupiter during the Present Opposition, P. Vincart, 471; the Moving Object near Jupiter, Prof. Albrecht, 407; Prof. Aitken, 407; the recently discovered Satellite of Jupiter, Mr. Melotte, 567; Mutual Occultations and Eclipses of Jupiter's Satellites, Mr. Whitmell, 567
- Kahn (M.), the Practical Application of Reinforced Concrete, 566
- Kailan (A.), Influence exercised by a Small Proportion of Water on the Rate of Formation of Ethyl Chloride, 304
- Kaiser (E.), Weathering Phenomena in Building Stones, 181
- Kamensky (M.), Ephemeris for Encke's Comet, 208; Encke's Comet, 1908a, 353

- Kanthack (Emilia), the Preservation of Infant Life, a Guide for Health Visitors, 268
- Kapp (Gisbert), Electric Traction, Prof. Ernest Wilson and Francis Lydall, 169
- Karny (H.), Revisio Conocephalidarum, 317
- Kausalitätsprinzip der Biologie, das, Dr. Friedrich Strecker, 507
- Kaye (F.), Influence of Formal on *Funtumia elastica*, 189
- Kaye (G. R.), Indian Mathematics, ii., Aryabhata, 359
- Kaye (R.), Notes on Indian Mathematics—Arithmetical Notation, 347
- Kaye (W. J.), Three Perceute Species from the Chanchamayo District of Peru, 551
- Kayser (Prof.), the Constancy of Wave-lengths of Spectral Lines, 234
- Kea, the Carnivorous Habits of the, Prof. W. B. Benham, 205; G. R. Marriner, 205
- Kearton (R.), the Fairyland of Living Things, 147
- Keeling (B. F. E.), Climate of Abbassia, 115
- Kellerman (Prof. W. A.), Death and Obituary Notice of, 493
- Kellogg (Vernon Lyman), Evolution and Animal Life, 242
- Kelman (Janet Harvey), the Sea-shore, shown to the Children, 533
- Kelvin (Lord), Death and Obituary Notice of, Prof. Silvanus P. Thompson, F.R.S., 175; Lord Kelvin's Funeral in Westminster Abbey, 177; Lord Kelvin, an Appreciation, 199; Lord Kelvin and the University of Glasgow, 200; Lord Kelvin and the Royal Society of Edinburgh, 253
- Kent, the Birds of, William J. Davis, 122
- Kent, Notes on the Birds of, R. J. Balston, Rev. C. W. Shepherd, and E. Bartlett, 511
- Kenyon (J.), Resolution of *sec-Oetyl* Alcohol, 166
- Kermode (P. M. C.), Manx Crosses, or the Inscribed and Sculptured Monuments from about the end of the Fifth to the beginning of the Thirteenth Century, 265
- Kerr (Dr. James), Report of the Education Committee of the London County Council submitting the Report of the Medical Officer (Education) for the Year ended March 31, 1907, 355
- Kew, Bulletin of Miscellaneous Information, Royal Botanic Gardens, 534
- Kidd (Benjamin), Animal Faculty of Orientation, 564
- Kidd (Dr. W.), Effects of Pressure upon the Direction of Hair in Mammals, 526
- Kidston (R., F.R.S.), Fossil Osmundaceae, 311
- Kienitz-Gerloff (Dr. Felix), Physiologie und Anatomie des Menschen mit ausblicken auf den ganzen Kreis der Wirbeltiere, 484
- Kilroe (J. R.), a Description of the Soil-geology of Ireland, based upon Geological Survey Maps and Records, with Notes on Climate, 4
- Kimberley, the Diamantiferous Rock of, Prof. T. G. Bonney, F.R.S., 248
- King (H. C.), Excavation of a Barrow at Chapel Carn Brea, Cornwall, 143; Holed Stone at Korrow, Cornwall, 143; Cist and Urn at Tregrifian Vean, 143
- King (P. E.), Constitution of Phenol- and Quinol-phthalein Salts, 47
- Kingzett (C. T.), Nature's Hygiene and Sanitary Chemistry, 106
- Kipping (F. S.), the Sulphonation of Benzylethylpropylsilicyl Oxide and of Benzylethylpropyl Silicane, 335; Organic Derivative of Silicon, Part. iv., the Optically Active Sulphobenzylethylpropylsilicyl Oxides, 431
- Kirkaldy (G. W.), Suggestion for Subdivision of Australasian Zoological Region, 16
- Kitchen (J.), the Deviation of Rand Bore-holes from the Vertical, 119
- Kites: Dr. Alexander Graham Bell's Experiments with his *Cygnus* Man-lifting Kite, 496
- Knaggs (Dr. H. G.), Death and Obituary Notice of, 278
- Knecht (Prof. E.), the Formation of Acetylene from Elementary Substances, 359
- Knobel (E. B.), a Suggested Explanation of the Ancient Jewish Calendar Dates in the Aramaic Papyri, 478
- Knott (Dr. C. G.), Seismic Radiations, 335
- Knott (Dr. John), Mosaic Origin of the Atomic Theory, 486
- Knox (Joseph), the Sulphur Anion and Complex Sulphur Anions, 454
- Koch (Prof.), Connection between Crocodiles and Sleeping Sickness, 16
- Koch (Dr. Ludwig), Pharmakognostisches Praktikum, 508
- Kolderup (C. F.), Scandinavian Glaciation, 468
- Kopff (Dr.), a Newly Discovered Bright Minor Planet (1908 B.M.), 281
- Korolikov (Frl.), Ephemeris for Encke's Comet, 208; Encke's Comet, 1908a, 353
- Korschelt (Prof. E.), Regeneration and Transplantation, 99
- Kowalski (Joseph de), Phosphorescence at Low Temperatures, 215
- Krassousky (K.), Order of Addition of Ammonia to Organic α -Oxides of Asymmetrical Structure, 359
- Krenner (J.), Spinel in Blast-furnace Slags, 41
- Kristelli (Prof. Leopold Schrötter von), Death of, 612
- Kritzinger (H. H.), Daniel's Comet, 1907d, 208; Ephemeris for Daniel's Comet, 1907d, 421; Comet 1907d, 544; Horizon and Prime-vertical Curves for Latitudes $+30^{\circ}$ to $+60^{\circ}$, 617
- Kroeber (Prof. A. L.), Religion of the Indians of California, 87; Anthropology of California, 379
- Kuckuck (Martin), die Lösung des Problems der Erzeugung (Archigonia, Generatio spontanea), 29
- Kuener (Prof. J. P.), die Zustandsgleichung der Gase und Flüssigkeiten und die Continuitätstheorie, 387
- la Grye (Bouquet de), Determination of the Time, both on Land and at Sea, with the Aid of Wireless Telegraphy, 551
- La Touche (T. H. D.), a Specific Gravity Balance for Large Rock Specimens, 221
- Laar (J. J. van), Lehrbuch der theoretischen Elektrochemie auf thermodynamischer Grundlage, 389
- Laboratories: the Place of the Laboratory in the Training of Engineers, Prof. A. L. Mellanby at Institution of Engineers and Shipbuilders in Scotland, 211; New Chemical Laboratories at Aberystwyth, 234; the National Physical Laboratory of 1907, 521; Laboratory and Field Manual of Botany, J. Y. Bergen and B. M. Davis, 554
- Lachgas, das, eine chemisch-historische Studie, Prof. Ernst Cohen, 434
- Lacroix (A.), New Mineral Species arising from the Athenian Plumbiferous Scoria of Laurium, 95; Crystallised Sodium Fluoride an Element of the Nepheline Syenites of the Los Islands, Villiumite, 359; New Silicate of Copper from the French Congo, 575
- Laine (E.), Utilisation of Turf for the Purification of Sewage, 287
- Laloue (G.), the Essence of *Tetranthera polyantha*, var. *citratra*, 407
- Lamarek, the International Memorial Statue of, Sir E. Ray Lankester, K.C.B., F.R.S., 149
- Lamb (Major G.), Etiology and Epidemiology of Plague, 585
- Lambert (P. A.), Computation and Mensuration, 555
- Lampland (Mr.), Saturn's Rings, 616
- Lancashire, the Flora of West, J. A. Wheldon and A. A. Wilson, 194
- Lancaster (A.), Death of, 324
- Land Slide near Lodève, 63
- Lankester (Sir E. Ray, K.C.B., F.R.S.), the International Memorial Statue of Lamarek, 149
- Lannelongue (M.), Influence of Feeding on the Course of Experimental Tuberculosis, 95
- Larard (C. E.), Practical Calculations for Engineers, 555
- Larmor (Prof. J., Sec.R.S.), on the Physical Aspect of the Atomic Theory, Wilde Lecture at Manchester Literary and Philosophical Society, 450
- Laryngology: Death of Prof. Leopold Schrötter von Kristelli, 612
- Laterizi, I. G. Revere, 508
- Latitude, the Systematic Error of, observed with a Zenith Telescope, Herr Battermann and K. Hirayama, 42
- Latitudes $+30^{\circ}$ to $+60^{\circ}$, Horizon and Prime-vertical Curves for, H. H. Kritzinger, 617
- Latreille (le Citoyen), Précis des Caractères génériques des Insectes disposés selon un Ordre naturel par, 77
- Lau (Dr.), Saturn's Rings, 234

- Launay (L. De), Granite in the Diamond-bearing Chimney of De Beers, 168
- Laurie (Charlotte L.), Introduction to Elementary Botany, 554
- Laveran (A.), Therapeutics of Trypanosomes, 47; Concerning *Trypanosoma congolense*, 623
- Le Chatelier (H.), the Density of Graphite, 287
- Le Dantec (Félix), *Éléments de Philosophie biologique*, 51
- Le Pla (M.), Quantitative Separation of Thallium from Silver, 551
- Le Rossignol (R.), the Sulphination of Phenolic Ethers and the Influence of Substituents, 502
- Le Roy (G. A.), Qualitative Examination of Ciders for Tartaric Acid, 215
- Le Sueur (H. R.), Action of Heat on α -Hydroxycarboxylic Acids, 551
- Lea (F. C.), Hydraulics, 530
- Leaf (Dr. Walter), Drifted Ice-crystals, 271
- Leaf-insects, Early Chinese Description of the, Kumagusu Minakata, 173
- Leake (H. Martin), Experimental Breeding of the Indian Cottons, 360
- Leather (Dr.), Composition of Indian Oil Seeds, 156; Pot Culture at Pusa, 136
- Lebeau (Paul), the Silicide of Magnesium, 383
- Lecher (Prof.), Verification of Ohm's Law, 304
- Ledingham (J. C. D.), Influence of Temperature on Phagocytosis, 623
- Leduc (A.), Atomic Weights of Nitrogen, Oxygen, and Carbon, 431
- Leduc (Prof. Stéphane), Diffusion and Osmosis, 510
- Leeds (E. T.), *Metricorynchus brachyrhynchus*, Deslong., from the Oxford Clay near Peterborough, 502
- Lees (Prof. C. H., F.R.S.), Effect of Low Temperatures on the Thermal Conductivities of Pure Metals and Alloys, 287
- Léger (E.), the OH(1)Cl(2:4:0) Trichlorophenol and its Transformation into Chloroquinones, 552
- Leguminous Crops, Seed and Soil Inoculation for, Prof. W. B. Bottomley, 330
- Leicestershire and South Derbyshire Coalfield, the Geology of the, C. Fox-Strangeways, 364
- Leighton (Marshall O.), Pollution of the Illinois and Mississippi Rivers by Chicago Sewage, 68
- Leitfaden, der neue, L. M. de la Motte Tischbrock, 268
- Leitthäuser (G.), Chemical Changes occurring when Air is Submitted to the Influence of Electricity, 41
- Lemoine (M.), Diamond-making, 254
- Leonhardi (M. Freiherr v.), New Facts about the Arunta, 41
- Lepidoptera: the Moths of the British Isles, Richard South, 483
- Lépiné (R.), the Sugar in the Blood Plasma, 47
- Leprieux (M.), an Alkaloid from Mistletoe, 120
- Lesage (Pierre), Action of a Magnetic Field of High Frequency on Penicillium, 215
- Lesbre (F. X.), the Excito-secretory Action of the Internal Branch of the Spinal Nerve on the Stomach and Pancreas, 216
- Lespienu (M.), γ -Oxytetrolic Acid, 384
- Letcher (Owen), Auriferous Banded Ironstones and Associated Schists of South Africa, 287
- Letellier (M.), Reducing Properties of Organo-metallic Compounds, 407
- Lévy (Prof. Albert), Death of, 230
- Levy (L. A.), Platinocyanides, 191
- Levy (L. E.), Obituary Notice of Prof. Angelo Heilprin, 136
- Lewes (Prof. V. B.), Liquid and Gaseous Fuels and the Part they play in Modern Power Production, 68
- Lewis (A. L.), Megalithic Remains in Central France, 503
- Lewis (E. J.), Inorganic Chemistry, 364
- Lewis (F. T.), Mimicry among South American Butterflies not Connected with Birds, 467
- Lewis (W. C. M.), Experimental Examination of Gibbs's Theory of Surface Concentration Regarded as the Basis of Absorption and its Application to the Theory of Dyeing, 477
- Lewis (Prof. W. J.), a Simple Method of Drawing Rhombohedral Crystals and of Deducing the Relations of their Symbols, 359
- Lewkowitzsch (Dr. J.), Niam Fat from the Seeds of *Lophura alata*, 189
- Ley (Capt. C. H.), Possibilities of a Topography of the Air, based on Balloon Observations, 188; Possibility of a Topography of the Air based on Balloon Observations made with Special Theodolites, 566
- Leydig (Prof. Franz von), Death of, 564
- Leyst (Prof. E.), Estimation of Amount of Cloud, 179
- Liebreich (Richard), Asymmetry of the Figure and its Origin, 503
- Life, the Prolongation of, Elie Metchnikoff, 289
- Light: Newton's Rings in Polarised Light, P. V. Bevan, 9; Reflection of Polarised Light, C. T. Whitmell, 103; the new Matriculation "Light," 482; the Dispersion of Light in Interstellar Space, Dr. C. Nordmann, 407
- Lighting: Theory of the Radiation of the Aer Incandescent Gas Mantle, M. Foix, 420; Relative Hygienic Values of Gas and Electric Lighting, Dr. Rideal, 613; Lighting with Incandescent Mantles, Jean Meunier, 623
- Lightning: Étude sur les Foudrolements d'arbres constatés en Belgique pendant les Années 1884-1906, E. Vanderlinden, 107
- Lignières (J.), New Method of Reaction of the Skin to Tuberculosis and its Utilisation in Diagnosis, 23
- Lindsay (Mr.), Molasses as Cattle Food, 500-1
- Linguistics: the Oceanic Languages, their Grammatical Structure, Vocabulary, and Origin, Dr. D. Macdonald, 460
- Linnean Society, 142, 190, 334, 406, 476, 527, 598; Mendelism and Sex, G. Archdall Reid, 236
- Linnean Society, New South Wales, 192, 264
- Linton (Edward), Parasites of Bermuda Fishes, 87
- Lippmann (Prof. G.), a New Method of Stereoscopic Photography, 452
- Lister Institute, Reports on Plague Investigations in India issued by the Advisory Committee appointed by the Secretary of State for India, the Royal Society and the, 585
- Literature relating to the Australian Aborigines, Dr. A. W. Howitt, 80; R. H. Mathews, 81
- Lithium in Radio-active Minerals, Sir W. Ramsay, K.C.B., F.R.S., 412
- Lithology: Modern, Illustrated and Defined, for the use of University, Technical, and Civil-Service Students, E. H. Ayle, 125
- Little (C.), the Calm Region in the Atmosphere near Calcutta, 455
- Liversidge (Prof. A.), Internal Structure of Gold Crystals, 263
- Liversidge (M. A.), Elementary Botany, 554
- Lloyd (Alfred H.), the Will to Doubt: an Essay in Philosophy for the General Thinker, 534
- Local Government Board, Scientific Work of the, Prof. R. T. Hewlett, 235
- Lock (Rev. J. B.), Arithmetic for Schools, 27
- Lock (R. H.), the Interpretation of Mendelian Phenomena, 32; Specific Stability and Mutation, 127
- Lockyer (Sir Norman, K.C.B., F.R.S.), Notes on Ancient British Monuments, 56, 82, 150, 249, 368, 414, 487, 536; Presence of Sulphur in Some of the Hotter Stars, 141
- Lockyer (Dr. William J. S.), the Permanency of Some Photo-visual Lenses, 94; the Total Solar Eclipse of January 3, 1908, 104, 274; Is Mars Habitable? a Critical Examination of Prof. Lowell's Book, "Mars and its Canals," with an Alternative Explanation, Dr. Alfred Russel Wallace, F.R.S., 337; Prominence and Coronal Structure, Lecture at Royal Society, 514
- Lodge (Sir Oliver, F.R.S.), Winding of Rivers in Plains, 779; the Stresses in Masonry Dams, 269; Modern Views on Electricity, 438; Supp. to March 5, viii
- Lothmann (Dr. W.), Measurement of the Zeeman Effect for the Principal Lines of Helium, 470
- Lomas (J.), the Winding of Rivers, 102
- London: London Day Training College for Teachers, 19; the Future Water Supply of London, 131; Report of the Education Committee of the London County Council, submitting the Report of the Medical Officer (Education) for the Year ended March 31, 1907, Dr. James Kerr, 355; Some London Problems, 473; Extensions at University College, London, 525
- Long (W. J.), Whose Home is in the Wilderness, some Studies of Wild Animal Life, 393

- Longe (Col. F. B.), General Report on the Survey of India during 1905-6, 470
- Longitudes, a Field Method of determining, E. B. H. Wade, 590
- Lorentz (Prof. H. A.), Lehrbuch der Physik, 580
- Louis (Prof. Henry), some Unsolved Problems in Metal-mining, "James Forrest" Lecture at Institution of Civil Engineers, 619
- Lounsbury (Mr.), the Plasmopara Vine Disease in Algeria, 591
- Lowell (Prof.), the Improvement of Celestial Photographic Images, 42; Mars as the Abode of Life, 66, 471; Saturn's Rings, 07, 116, 616; Photographs of Mars, 182; Evolution of Life, 350; Planetary Photography, 402; the Habitability of Mars, 461; Presence of Water Vapour in the Atmosphere of Mars, 503, 606
- Lowell's (Prof.) Book, "Mars and its Canals," with an Alternative Explanation, Is Mars Habitable? a Critical Examination of, Dr. Alfred Russel Wallace, F.R.S., Dr. William J. S. Lockyer, 337
- Lowry (Dr. T. M.), Chemistry of the Silver Voltameter, 165; Action of Carbonyl Chloride as an Agent for arresting Isomeric Change, 143
- Loziński (Ritter von), Glacial Deposits and Löss of Northern Galicia, 184
- Lubimenco (W.), the Production of Chlorophyll in the Higher Plants at Different Luminous Intensities, 216
- Ludendorff (Dr. H.), Provisional Elements for the Spectroscopic Binary α Andromedæ, 182; Variation in the Radial Velocity of β Ursæ Majoris, 520
- Lull (R. S.), Evolution of the Elephant, 494
- Lunar "New Jerusalem," a, Rev. G. B. Berry, 163
- Lushington (A. W.), Sucker Reproduction in Kistna District of Madras, 256
- Lutz (Dr. C. W.), the Filament Electrometer, 401
- Lydall (Francis), Electric Traction, 169
- Lynch (R. I.), the Garden Beautiful, 300
- Lynn (W. T.), Comets due to return this Year, 238
- Lyon (Captain H. G.), Hydrology in Egypt, 21; Distribution of Standard Time in Egypt, 497
- McAtee (W. L.), the Food of American Birds, 564
- McClintock (Sir F. L., K.C.B., F.R.S.), Death and Obituary Notice of, 61
- Macco (A.), Ueber die südafrikanischen Diamantenlagerstätten, 224
- McCoy (Prof. Herbert N.), the Occurrence of Copper and Lithium in Radium-bearing Minerals, 79
- Macdonald (Dr. D.), the Oceanic Languages, their Grammatical Structure, Vocabulary, and Origin, 460
- Macdonald (Sir J. D., K.C.B., F.R.S.), Death and Obituary Notice of, 349
- MacDougall (Dr.), Heredity and Environic Forces, 378
- MacDowall (Alex. B.), Rothesay Summers and Greenwich Winters, 438
- McKendrick (Prof. John G., F.R.S.), the Mechanism of Speech, Alexander Graham Bell, 483; Mendelian Characters among Shorthorns, 582
- Mackenzie (T. D.), Electrical Discharge in Monatomic Gases, 310
- Mackie (Dr. D.), Proposed Alteration in the Calendar, 534
- Maclauchlan (John), Death of, 63
- McLennan (Prof. J. C.), the Radio-activity of Ordinary Metals, the Penetrating Radiation from the Earth, 607
- Maenutt (B.), the Elements of Mechanics, 29
- Maquisten (A. P.), the Concentration of Ores, 181
- Madagascar, the Fauna of, Frank E. Beddard, F.R.S., 8
- Madrepolaria of the Hawaiian Islands and Laysan, Recent, T. Wayland Vaughan, Prof. S. J. Hickson, F.R.S., 499
- "Magic Mirror" Effects, Douglas Carnegie, 55
- Magnetism: Magnetic Oscillators as Radiators in Wireless Telegraphy, Dr. J. A. Fleming, 71; the Diurnal Variation of Terrestrial Magnetism, Prof. Arthur Schuster, F.R.S., 164; Results obtained by the Ziegler Polar Expedition of 1903-5, J. A. Fleming, 207; Magnetic Results obtained by the National Antarctic Expedition of 1901-4, Dr. C. Chree, 453; Action of a Magnetic Field of High Frequency on Penicillium, Pierre Lesage, 215; Magnetic Declination at Kew Observatory, 1890-1900, Dr. C. Chree, F.R.S., 238; Comparison of the Energy Losses due to Hysteresis in Iron, Steel, and Nickel, in Alternating and Rotating Magnetic Fields Respectively, P. Weiss and V. Planer, 327; the First Known Mention of the Compass, Prof. E. Wiedemann, 377; Best Method for demagnetising Iron in Magnetic Testing, C. W. Burrows, 401; Sensitive State induced in Magnetic Materials by Thermal Treatment, J. G. Gray and A. D. Ross, 407; Measurement of the Zeeman Effect for the Principal Lines of Helium, Dr. W. Lohmann, 470; Magnetic Rays, a New Type of Compas, Prof. Augusto Righi, 470; Déviations des Compas, Pierre Engel, 534; Handbuch der Physik, Dr. A. Winkelmann, 559; Magnetic Observations in Egypt, 1895-1905, 565
- Magson (E. H.), Action of Carbonyl Chloride as an Agent for arresting Isomeric Change, 143
- Maignon (F.), Mechanism of the Transformation of Glycogen into Glucose by the Muscles and the Animal Tissues, 23; the Excito-secretory Action of the Internal Branch of the Spinal Nerve on the Stomach and Pancreas, 216
- Maihle (A.), Direct Hydrogenation of some Aromatic Diones, 167; Direct Hydrogenation of the Aromatic Quinones, 455
- Malaria: the Prevention of Malaria, Prof. Ronald Ross, 391; Malaria, a Neglected Factor in the History of Greece and Rome, W. H. S. Jones, 457
- Mallet (Dr. J. W., F.R.S.), Results of the Interaction of Mercury with Alloys of other Metals, 333
- Malloch (A., F.R.S.), Stability in Flight, 203; Sensibility of the Ear to the Direction of Explosive Sounds, 332
- Mammalian Molar Teeth, Evolution of, to and from the Triangular Type, H. F. Osborn, 435
- Manchester, British Pharmaceutical Conference at, Immunity to Disease among Plants, Prof. F. E. Weiss, 20
- Manchester Literary and Philosophical Society, 23, 191, 359, 599, 623; Wilde Lecture at, on the Physical Aspect of the Atomic Theory, Prof. J. Larmor, Sec.R.S., 450
- Mann (Albert), Report on the Diatoms of the *Albatross* Voyages in the Pacific Ocean, 1888-1904, 91
- Mann (E. A.), Chemical Examination of West Australian Poison Plants, 180
- Manville (O.), les Découvertes modernes en Physique, 458
- Manx Crosses, or the Inscribed and Sculptured Monuments of the Isle of Man from about the End of the Fifth to the Beginning of the Thirteenth Century, P. M. C. Kermodé, 265
- Maquenne (L.), Pure Starch, Amylose, 407
- Marage (Dr. M.), Photography of the Vibrations of the Voice, 527; Method of Photographing the Vibrations of a thin India-rubber Membrane acted on by the Human Voice, 589
- Marie (C.), the Oxidation of Platinum, 455
- Marine Biology: Report on the Diatoms of the *Albatross* Voyages in the Pacific Ocean, 1888-1904, Albert Mann, 91; Correlation of Modifications of the Limpet-shell with Environmental Conditions, E. S. Russell, 189; New Pteropod Mollusc, *Paedoclitone doliiformis*, C. H. Danforth, 325; the Plankton of the English Channel, Dr. L. H. Gough, 524
- Maritime Meteorology, Notes on, Commander M. W. Campbell Hepworth, C.B., 126
- Marriner (G. R.), the Carnivorous Habits of the Kea, 205
- Mars: Mars as the Abode of Life, Prof. Lowell, 66, 471; Comparisons of the Places of Mars for the Oppositions of 1907 and 1909, Dr. Downing, 67; Photographs of Mars, Prof. Lowell, 182; Is Mars Habitable? a Critical Examination of Prof. Lowell's Book, "Mars and its Canals," with an Alternative Explanation, Dr. Alfred Russel Wallace, F.R.S., Dr. William J. S. Lockyer, 337; the Possibility of Life in Mars, C. O. Bartrum, 392; Dr. J. W. Evans, 302, 413; Dr. W. Ainslie Hollis, 438; Prof. Percival Lowell, 461; Dr. G. Johnstone Stoney, F.R.S., 461; Planetary Photography, Prof. Percival Lowell, 402; Water Vapour in the Martian Atmosphere, William E. Rolston, 442; Mr. Slipper, 497; the Presence of Water Vapour in the Atmosphere of Mars, Prof. Percival Lowell, 503, 606
- Marsden (H.), the Sulphonation of Benzylethylpropylsilyl Oxide and of Benzylethylpropyl Silicane, 335
- Marsh (Mr.), Potomac River Basin, 68

- Marsh-birds, Home-life of some, Emma L. Turner and P. H. Bahr, 393
- Martel (E. A.), Variations of Temperature of the Spring of Sainte-Baume (Var), 576
- Martin (Geoffrey), Practical Chemistry for Army and Matriculation Candidates, 74
- Martin (H. M.), a Point in the Mathematical Theory of Elasticity, 198; the Stresses in Masonry Dams, 269, 320, 392
- Martin (L. A., jun.), Text-book of Mechanics, 315
- Martinmas in May, Rev. C. S. Taylor, 510
- Mascart (Jean), Simultaneous Observations of Jupiter, 259
- Masó (Rev. M. S.), Rainfall of the Philippine Archipelago, 64
- Masonry Arches, Symmetrical, M. A. Howe, 507
- Masonry Dams, an Experimental Study of Stresses in, Karl Pearson, F.R.S., A. F. Campbell Pollard, C. W. Wheen, and L. F. Richardson, Prof. E. Brown, 209; H. M. Martin, 269, 320, 392; Sir Oliver Lodge, F.R.S., 269; Prof. Karl Pearson, F.R.S., 269, 366; Sir John W. Outley, K.C.I.E., and Dr. A. W. Brightmore, J. S. Wilson and W. Gore, at Institution of Civil Engineers, 303
- Massey (Gerald), Ancient Egypt the Light of the World, a Work of Reclamation and Restitution, 291
- Masol (L.), Relations between Lecithin and Tubercle Bacilli and Tuberculin, 552
- Masterman (Dr. A. T.), a Possible Case of Mimicry in the Common Sole, 477
- Materials, Strength of, W. C. Poplewell, 412
- Materials, the Testing of, 404
- Mathematics: Practical Mathematics, Prof. John Perry, F.R.S., 6; Dr. Edward Sang's Collection of MS. Calculations in Trigonometry and Astronomy, Dr. R. H. Traquair, F.R.S., 13; Arithmetic for Schools, Rev. J. B. Lock and V. M. Turnbull, 27; Arithmetic, chiefly Examples, G. W. Palmer, 27; a Modern Arithmetic, with Graphic and Practical Exercises, H. Sydney Jones, 27; die typischen Geometrien und das Unendliche. B. Petrovics, 28; die Ausrechnungrechnung nach der Methode der kleinsten Quadrate, F. R. Helmet, 52; Death of Prof. T. Barker, 85; Simple Method of calculating First and Second Moments of certain Elementary Figures, R. F. Muirhead, 88; Mathematical Society, 94, 190, 263, 382, 478; Invariants of a Binary Quintic and the Reality of its Roots, Dr. H. F. Baker, 94; Application of Quaternions to the Problem of the Infinitesimal Deformation of a Surface, J. E. Campbell, 95; Biographical Sketch of Robert Rawson, Rev. Robert Harley, F.R.S., 157; Graphical Interpolation, F. J. W. Whipple, 103; Mathematische und mikroskopisch-anatomische Studien über Blattstellungen, Dr. G. van Iterson, jun., 145; a Point in the Mathematical Theory of Elasticity, H. M. Martin, 198; Prof. E. Brown, 221; the Stresses in Masonry Dams, Karl Pearson, F.R.S., A. F. Campbell Pollard, C. W. Wheen, and L. F. Richardson, Prof. E. Brown, 209; H. M. Martin, 269, 320, 392; Sir Oliver Lodge, F.R.S., 269; Prof. Karl Pearson, F.R.S., 269, 366; Sir John W. Outley, K.C.I.E., and Dr. A. W. Brightmore, J. S. Wilson and W. Gore at Institution of Civil Engineers, 303; Death of Prof. Albert Lévy, 230; Easy Exercises in Algebra for Beginners, W. S. Beard, 315; Plane Geometry for Secondary Schools, C. Davison and C. H. Richards, 315; Cartesian Plane Geometry, Charlotte A. Scott, 315; a Sequel to Elementary Geometry, J. W. Russell, 315; Text-book of Mechanics, L. A. Martin, jun., 315; Elementary Statics, W. P. Borchardt, 315; Elementary Trigonometry, C. Hawkins, 315; Mathematical Education and Research, 331; the Canterbury Puzzles and other Curious Problems, H. E. Dudeney, 341; Notes on Indian Mathematics—Arithmetical Notation, R. Kaye, 347; Indian Mathematics, II., Aryabhata, G. R. Kaye, 350; the Speed of Racing Animals, Prof. John Perry, F.R.S., 389; Tabulated Values of certain Integrals, C. E. Adams, 462; Harry M. Elder, 486; the Forthcoming Mathematical Congress at Rome, Prof. G. H. Bryan, F.R.S., 464; the International Mathematical Congress at Rome, Prof. G. H. Bryan, F.R.S., 582; the Projective Geometry of some Covariants of a Binary Quintic, Prof. E. B. Elliott, 478; Suggestion for a New Economic Arithmetic, Prof. T. N. Carver, 496; Computation and Mensuration, P. A. Lambert, 555; a First Statics, C. S. Jackson and R. M. Milne, 555; Practical Calculations for Engineers, C. E. Larard and H. A. Golding, 555; a First Course in the Differential and Integral Calculus, Dr. W. F. Osgood, 577; Synopsis of Linear Associative Algebra, J. B. Shaw, 603; an Introduction to the Theory of Multiply-periodic Functions, Dr. H. F. Baker, Supp. to March 5, v
- Mathews (R. H.), Literature relating to the Australian Aborigines, 80
- Matley (Dr. C. A.), the Carboniferous Rocks at Lough-Dunecan, 527
- Matter, the Corpuscular Theory of, Prof. J. J. Thomson, F.R.S., 505
- Matter and Intellect: a Reconciliation of Science and the Bible, Andrew Allan, 341
- Matter, Life, and Mind, the Evolution of, W. Stewart Duncan, 30
- Matter, the Polarity of, Alex. Clark, 210
- Matthews (Sir William, K.C.M.G.), Inaugural Address at Institution of Civil Engineers, 14
- Mattingley (A. H.), Wanton Slaughtering of Egrets, 87
- Maublan (M.), Disease of the Pine in the Jura, 23
- Maurer (Ed.), Austenite, 600
- Maurer (E. R.), Principles of Reinforced Concrete Construction, Supp. to March 5, vi
- Mavor (H. A.), the Electric Propulsion of Ships, 543
- Maw (Mr.), the Appearance of Neptune in Small Telescopes, 258
- Mawley (E.), Phenological Observations for 1907, 599
- Maximum of Mira, 1906, Naozo Ichinohe, 158
- May (Dr. W. Page), the Nervous System of Vertebrates, Prof. J. B. Johnston, 73
- May Gorseeds, Rev. John Griffith, 128
- May, Martinmas in, Rev. C. S. Taylor, 510
- Mayer (André), Influence of the Reaction of the Medium on the Size of the Colloidal Granules, 119
- Mayo (Nelson S.), the Diseases of Animals, 436
- Mayow (John), Medico-physical Works of, (1674), 339
- Measurements: the White and Bean Celluloid Area Scale, Casella and Co., 233
- Measures, a Series of Standard Weights and, for Securing Uniformity in Scientific Papers, 114
- Mechanics: the Elements of Mechanics, W. S. Franklin and B. Macnutt, 29; Text-book of Mechanics, L. A. Martin, jun., 315
- Mechanism: a Diabolo Experiment, C. V. Boys, 188
- Medicine: Text-book of Organic Chemistry for Medical Students, Dr. G. v. Bunge, 146; Physiologisches Praktikum für Mediziner, Prof. Max Verwor, 148; Death of Sir Alfred B. Garrod, F.R.S., 203; the Induction of Anesthesia by Chloroform, 226; Prolonged Anesthesia by Mixtures of Oxygen and Ethyl Chloride, Pierre Rosenthal and Albert Berthelot, 263; the Interdependence of Medicine and other Sciences, Dr. W. H. Welch, at Chicago Meeting of American Association, 283; Death of Sir Thomas McCall Anderson, 208; Death of Prof. J. B. Pettigrew, F.R.S., 324; Obituary Notice of, 348; Medico-physical Works of John Mayow (1674), 339; Death and Obituary Notice of Sir J. D. Macdonald, K.C.B., F.R.S., 349; Report of the Education Committee of the London County Council submitting the Report of the Medical Officer (Education) for the Year ended March 31, 1907, Dr. James Kerr, 355; Memorandum on Medical Inspection of Children in Public Elementary Schools, under Section 13 of the Education (Administrative Provisions) Act, 1907, 426; Memorandum by the British Medical Association on the Circular of the Board of Education, 426; Studies in the Medicine of Ancient India, Dr. A. F. Rudolf Hoernle, C.I.E., 533; Lehrbuch der medizinischen Physik, Prof. H. Boruttat, 604; Death of Prof. Leopold Schrötter von Kristelli, 612
- Mee (Arthur), a Bright Meteor, 18
- Melanin Variety of the "Peppered Moth," the, A. Bacot, 204
- Meldola (Prof. R., F.R.S.), Chemie der höheren Pilze, eine Monographie, Dr. Julius Zellner, 553
- Meldrum (A. N.), a β -Lactic Acid from Acetone and Malonic Acid, 383

- Mellanby (Prof. A. L.), the Place of the Laboratory in the Training of Engineers, Lecture at Institution of Engineers and Shipbuilders in Scotland, 211
- Mellish Comet (1907e), 17, 138; M. Borrelly, 17; G. van Biesbroeck, 17; Dr. M. Ebell, 18, 66
- Mellone (Dr. S. H.), Elements of Psychology, 267
- Melotte (P.), a Possible New Satellite to Jupiter, 470; the Recently Discovered Satellite of Jupiter, 567
- Mendelian Characters among Shorthorns, Prof. James Wilson, 509, 559; Prof. Karl Pearson, F.R.S., 559; Prof. John G. Kendrick, F.R.S., 582
- Mendelian Phenomena, the Interpretation of, Geo. P. Mudge, 8; G. Archdall Reid, 9, 54; R. H. Lock, 32; J. T. Cunningham, 54; H. H. O'Farrell, 271
- Mendelism and Sex, G. Archdall Reid, at Linnean Society, 256
- Ménière (P.), New Method of estimating the Vapour of Mercury in Air, 576
- Mercury: the Transit of Mercury, M. Bigourdan, 18; M.M. Javelle and Simonin, 116; M. Charlois, 116; M. Bourget, 116; M. Borrelly, 116; M. Esmiol, 116; Abbé Th. Moreux, 116; Comte de la Baume Pluvinel, 116; M. Gautier, 567; M. Pidoux, 567; Mercury as a Morning Star, 115
- Mercury, Satellites of Yellow and Green Lines of, Prof. H. Nagaoka, 581
- Meridian Circle Observations of Parallax Stars, 544
- Mérin (A. A. C. E.), "Ghost Images," 280
- Merrill (G. P.), the Canyon Diablo Meteorites, 208
- Merrill (J. P.), Catalogue of the Type and Figured Specimens of Fossils, Minerals, Rocks, and Ores in the Department of Geology, U.S. Mus., 91
- Metabolism, the Influence of Inanition on, Francis Gano Benedict, 610
- Metallography, Death of Dr. H. C. Sorby, F.R.S., 403; Obituary Notice of, 465
- Metalurgy: Spinel in Blast-furnace Slags, J. Krenner, 41; Phenomena of Permanent Deformation of Metals, G. H. Gulliver, 41; the Separation of Tin-oxide from Wolfram, A. Treloar and G. Johnson, 119; the Assay of Telluride Ores, G. T. Holloway and L. E. B. Pearce, 190; the Refining of Copper, D. Saito, 206; the Solubility of Graphite in Iron, Georges Charpy, 215; Gases occluded in Steels, G. Belloc, 215; the Extraction of the Gases contained in Metals, O. Boudouard, 215; Constitution of Cast Irons containing Manganese, L. Guillet, 288; les Aciers spéciaux, L. Revillon, 317; Alloys of Gold and Tellurium, Dr. T. K. Rose, 406; Method of settling Slimes as applied to their Separation from Solution in Cyanide Treatment, H. G. Nichols, 406; the Evolution of Malleable Cast Iron, W. H. Hatfield, 543; the Corrosion of Iron and Steel, Dr. Frank Clowes, 560; Iron and Steel, J. H. Stansbie, 579; Some Unsolved Problems in Metallurgy, "James Forrest" Lecture at Institution of Civil Engineers, Prof. Henry Louis, 610
- Metals: la Tecnologia delle Soldature autogene dei Metalli, Prof. S. Ragno, 508; the Radio-activity of Ordinary Metals, the Penetrating Radiation from the Earth, Prof. J. C. McLennan, 607
- Metchnikoff (Élie), the Prolongation of Life, 289
- Meteoric and Artificial Nickel-iron Alloys, Thermomagnetic Analysis of, S. W. J. Smith, 574
- Meteorites: the Williamette Meteorite, Dr. H. A. Ward, 12; the Bath Furnace Aerolite, Dr. H. A. Ward, 12; Indian Meteorites, L. L. Fermor, 13; Analyses of Meteoric Irons, Prof. O. C. Farrington, 14; the Canyon Diablo Meteorites, G. P. Merrill and Wirt Tassin, 208
- Meteorology: Remarkable Hailstorm in Cairo, 15; a Horticultural Hygrometer, 40; Rainfall of the Philippine Archipelago, Rev. M. S. Masó and Rev. Father Algué, 64; Climate of Eritrea, Captain Tancredi, 88; the Week's Weather, 88, 157, 232, 256, 419, 612; Climate of Abbassia, B. F. E. Keeling, 115; Notes on Maritime Meteorology, Commander M. W. Campbell Hepworth, C.B., 126; Scientific Balloon Ascents of July 22-27, 136; Results obtained by the Balloon Observations made in the British Isles, July 22-27, 187; the Balloon Ascent of July 25, 1907, M. J. Vincent, 445; Possibilities of a Topography of the Air based on Balloon Observations, Capt. C. H. Ley, 188; Possibility of a Topography of the Air based on Balloon Observations with Special Theodolites, Capt. C. H. Ley, 566; Unmanned Balloon Ascents in 1907 at Munich, A. Schmauss, 495; the Lagging of Temperature Changes at Great Heights behind those at the Earth's Surface shown by Records of Sounding Balloons liberated at St. Louis in April and May, 1906, H. H. Clayton, 495; Airships Past and Present, together with Chapters on the Use of Balloons in Connection with Meteorology, Photography, and the Carrier Pigeon, A. Hildebrandt, 562; the Periodical Variations of Atmospheric Pressure, Dr. E. Herrmann, 157; Globular Lightning, Elibu Thomson, 179; Estimation of Amount of Cloud, Prof. E. Leyst, 179; Royal Meteorological Society, 187, 453, 478, 599; Meteorological Observations at the British kite Stations, Session 1906-7, Miss M. White, T. V. Pring, and J. E. Petavel, 188; a Micromanometer, L. Bairstow, 188; Indications of Approaching Frost, R. Strachan, 188; Weather for 1907, 204; Rainfall of the British Isles during the past Year, Dr. H. R. Mill, 279; Summary of Greenwich Air-temperature Observations, 1841-1905, W. Ellis, F.R.S., 206; Relations between Mortality of Infants and High Temperatures. Dr. E. Van Everdingen, 206; Results obtained by the Ziegler Polar Expedition of 1903-5, J. A. Fleming, 207; I brontidi del Bacino Bolsense, Barisal Guns, Prof. L. Palazzo, 256; Drifted Ice-crystals, Dr. Walter Leaf, 271; Stock Frost or Ground Ice, Rev. John J. Hampson, 295; James Thomson, 366; Prof. H. T. Barnes, 412; Rainfall and Water Supply, Dr. H. R. Mill, at Royal Meteorological Society, 286; Rainfall of the Ligurian Riviera, Dr. Eredia, 301; Electrical Phenomena of the Atmosphere and their Relations with Solar Activity, Prof. Schuster, 301; Death of A. Lancaster, 324; Atmospheric Electricity and Fog, Dr. Charles Chree, F.R.S., 343; Auroral Characteristics of Clouds, George C. Simpson, 344; Meteorological Observations in South Australia and the Northern Territory during 1905, Sir Charles Todd, 352; Memoirs of the Indian Meteorological Department, being Occasional Discussions and Compilations of Meteorological Data relating to India and Neighbouring Countries, Vol. xviii., Part iii., V., a Discussion of the Anemographic observations recorded at Allahabad from September, 1890, to August, 1904; VI., a Discussion of the Anemographic Observations recorded at Lucknow from June, 1878, to October, 1892, Sir John Eliot, K.C.I.E., F.R.S., 353; Death of Lieut.-General Sir Richard Strachey, G.C.S.I., F.R.S., 373; Obituary Notice of, Dr. W. N. Shaw, F.R.S., 395; the Isothermal Layer of the Atmosphere, W. H. Dines, F.R.S., 390, 462, 486; Dr. Charles Chree, F.R.S., 437; C. E. Stromeyer, 485; Death of Prof. Ivan Stožir, 397; Meteorology of October and November, 1907, 419; Rothsay Summers and Greenwich Winters, Alex. B. MacDowall, 438; "Black Rain" in Ireland on October 8-9, 1907, Dr. O. Boeddicker, 445; the Formation of "Snow Rollers" at Ryton on Dunsmore, January 29-30, 1907; C. Browett, 453; Comparison of Ships' Barometer Readings with those deduced from Land Observations, E. Gold, 453; the Calm Region in the Atmosphere near Calcutta, C. Little, 455; Machines for driving away Hail, J. Violle, 455; Death of Sir John Eliot, K.C.I.E., F.R.S., 467; Obituary Notice of, 490; Moon's Influence on the Wind Components at Hamburg, Prof. J. Schneider, 469; Typhoon at the Caroline Islands, March, 1907, Father Algué, 469; the Dawn of Meteorology, Dr. G. Hellmann, 478; a Case of Ball Lightning, Isidore Bay, 479; Comparison of the Rainfall of Sydney and Melbourne, 1876 to 1905, A. Duckworth, 479; the Supposed Cloud-dispersing Power of the Full Moon, J. R. Sutton, 518; Climatology of the Past Year at Juvisy, 522; Variations of Temperature of the Spring of Sainte-Baume (Var), E. A. Martel, 576; Report of Falmouth Observatory, 1907, 589; Stonyhurst College Observatory Results for 1907, 580; Phenological Observations for 1907, E. Mawley, 590; Anticyclonic Belt of the Southern Hemisphere, Colonel H. E. Rawson, 599; an Extremely Sensitive Electric Hygroscope, J. Pionchon, 600
- Meteors: a Bright Meteor, Arthur Mee, 18; T. F. Connolly, 115; November Meteors, John R. Henry, 31; the Spectra

- of two Meteors, M. Blakjo, 234; the Study of Meteor Trains, Prof. Trowbridge, 328; Meteors observed on January 2, P. Muusmann and H. Wanning, 353; April Meteors, John K. Henry, 535; the Meteors of Halley's Comet, W. F. Denning, 619
- Metric and British Systems of Weights, Measures, and Coinage, the Dr. F. Mollwo Perkin, 77
- Metrology: the Metric and British Systems of Weights, Measures, and Coinage, Dr. F. Mollwo Perkin, 77; Mining Tables, Dr. F. H. Hatch and E. J. Valentine, 317; the Weights and Measures of International Commerce, 317; les Récents Progrès du Système métrique, Ch. Ed. Guillaume, 611
- Meunier (Jean), Action of an Incandescent Electric Conductor on the Gases which surround it, 167; Lighting with Incandescent Mantles, 623
- Meyer (André), Derivatives of Phenylisoxazolone, 527
- Meyer (Fernand), Action of Gold on the Dioxide of Sodium and Barium, 95
- Michael (A. D.), New Acari from New Zealand, 142
- Michaelson (Prof. W.), die Fauna Südwest-Australiens, Ergebnisse der Hamburger südwest-australischen Forschungsreise, 1905, 51
- Michelson's Echelon Grating, an Early Acoustical Analogue of, Prof. P. Zeeman, 247
- Micklethwait (Miss F. M. G.), Diazo-reaction in the Diphenyl Series, 431
- Micrometer Observations of Phæbe, Prof. Barnard, 421
- Microscopy: Royal Microscopical Society, 46, 188, 311, 454, 551; Photographic Plates prepared by the Lumière Starch-grain Process for Colour Photography, Conrad Beck, 188; Two Inexpensive Microscopes, C. L. Curties, 188; the "Vitascope," Newton and Co., 233; "Ghost Images," A. A. C. E. Merlin, 280; Microscopes of New Design made by Messrs. Leitz, J. W. Oglivy, 311; the Construction, Theory, and Use of the Microscope, E. J. Spitta, 314; New Flagellate Monad (*Copromonas subtilis*), C. C. Dobbell, 350; Death and Obituary Notice of Prof. W. Stratford, 374; Method of demonstrating the Syncytial Appendages of the Placental Villi, Dr. Duckworth, 479; Mikroskopisches und physiologisches Praktikum der Botanik für Lehrer, G. Müller, 481; the World of the Infinitely Small, Prof. Gruner, 543; Lehrbuch der mikroskopischen Technik, Dr. Bernhard Rawitz, Prof. R. T. Hewlett, 605
- Miers (Prof. H. A., F.R.S.), Order in which Scientific Ideas should be Presented, 283
- Mikkelsen (Captain Ejnar), Return of, and the Anglo-American Polar Expedition, 541
- Mill (Dr. H. R.), Rainfall of the British Isles during the Past Year, 279; Rainfall and Water-supply, Address at Royal Meteorological Society, 286
- Millais (J. G.), Newfoundland and its Untrodden Ways, 223
- Miller (G. S.), the Family and Genera of Bats, 91
- Milochau (G.), the Caloric Solar Radiation, 350
- Milne (Prof. John, F.R.S.), British Association Seismology, 108; Recent Earthquakes, Discourse at Royal Institution, 592
- Milne (R. M.), a First Statics, 555
- Mimicry among South American Butterflies not connected with Birds, F. T. Lewis, 467
- Minakata (Kumagusu), Early Chinese Description of the Leaf-insects, 173
- Minchin (Prof. E. A.), the Development of Trypanosomes in Tsetse-flies and other Diptera, 494
- Minchin (Prof. George M., F.R.S.), the Photoelectric Property of Selenium, 173, 222
- Mineralogy: the Coloration of Crystallised Alumina, F. Bordas, 17; Copper in Andesite from Fiji, H. I. Jensen, 23; the Occurrence of Copper and Lithium in Radium-bearing Minerals, Prof. Herbert N. McCoy, 79; Lithium in Radio-active Minerals, Mlle. Gleditsch, 407; Catalogue of the Type and Figured Specimens of Fossils, Minerals, Rocks, and Ores in the Department of Geology, U.S. Museum, J. P. Merrill, 91; New Mineral Species, arising from the Athenian Plumbiferous Scoria of Laurium, A. Lacroix and A. de Schulten, 95; Artificial Reproduction of Heavy Spar, Celestine, and Anglesite, Paul Gaubert, 66; Association of Helium and Thorium in Minerals, Hon. R. J. Strutt, F.R.S., 141; Hopeite and other Zinc Phosphates from Broken Hill Mines, L. J. Spencer, 143; Mineralogical Society, 143, 358, 574; Analysis of Meteoric Stone seen to Fall on April 30, 1906, on the New Jersey Shore, Dr. E. Goldsmith, 136; Discovery of Thorianite in Ceylon, Mr. Parsons, 185; "Kimberlite" and the Source of the Diamond in South Africa, Dr. F. H. Hatch, 224; the Sutherland Volcanic Pipes and their Relationship to other Vents in South Africa, A. W. Rogers and A. L. du Toit, 224; the Diamond Pipes and Fissures of South Africa, H. S. Harger, 224; the Occurrence in Kimberlite of Garnet-pyroxene Nodules carrying Diamonds, G. S. Corstorphine, 224; Kimberlite Dykes and Pipes, F. W. Voit, 224; the Origin of Diamonds, F. W. Voit, 224; the Diamantiferous Rock of Kimberley, Prof. T. G. Bonney, F.R.S., 248; Endeavour to apply Recent Chemical Theories towards elucidating the Origin and Formation of the Diamond from Quartz-bearing Rocks, Mr. Schips, 542; Geological Survey of the Eastern Portion of Griqualand West, A. L. du Toit, 224; Ueber die südafrikanischen Diamantlagerstätten, A. Macco, 224; Untersuchungen über einige südafrikanische Diamantlagerstätten, R. Beck, 224; M. Lemoine's Case, 224; the Formation of certain Precious Stones of Crystallised Alumina, F. Bordas, 263; Internal Structure of Gold Crystals, Prof. A. Liversidge, 263; Zeolites from the Neighbourhood of Belfast, F. N. A. Fleischmann, 358; Strüverite and its Relation to Ilmenorut, Dr. G. T. Prior and Dr. F. Zamboni, 358; Crystallised Sodium Fluoride an Element of the Nepheline Syenites of the Los Islands, Villiumite, A. Lacroix, 359; Possible Presence of Microscopic Diamonds on the Sea Floor and in a Specimen of Vegetable Earth, J. Thoulet, 407; the Weathering of Coal, Prof. S. W. Parr and N. D. Hamilton, 468; Lehrbuch der Chemie und Mineralogie für die vierte Klasse der Realschulen, Franz von Hemmelmayr and Dr. Karl Brunner, 484; Thermomagnetic Analysis of Meteoric and Artificial Nickel-iron Alloys, S. W. J. Smith, 574; Metamorphic Minerals in Calcareous Rocks in the Bodmin and Camelford Areas, G. Barrow and H. H. Thomas, 574; Supplementary Notes on kaolinite, A. B. Dick, 575; New Form of Quartz-wedge, J. W. Evans, 575; New Silicate of Copper from the French Congo, A. Lacroix, 575
- Minerals: Mineral Production of Canada, 381; Mineral Production of Canada in 1907, 566; Mineral Production of India during 1906, T. H. Holland, F.R.S., 400
- Minet (Adolphe), New Electric Arc Furnace applicable to Laboratory Researches, 359
- Minimising of Maurice, the, being the Adventures of a Very Small Boy among Very Small Things, Rev. S. N. Sedgwick, 508
- Mining: Origin of the Gold in the Rand Banket, Prof. J. W. Gregory, 22; Death of M. Walton Brown, 111; Labour-saving Appliances in Transvaal Mines, E. J. Way, 114; the Deviation of Rand Bore-holes from the Vertical, J. Kitchin, 119; Tin-mining Industry, World's Production of Tin Last Year, A. Selwyn-Brown, 157; the Concentration of Ores, A. P. Macquisten, 181; the Assay of Telluride Ores, G. T. Holloway and L. E. B. Pearse, 190; Product of the World's Gold Mines for the Year 1906, T. F. Van Wagenen, 280; Gold-mining for the Year 1904-5 in Mysore, 301; Goldfields of Western Australia, C. G. Gibson, 400; the Great Fitzroy Copper and Gold Mine, Queensland, B. Dunstan, 468; Progress of the Kolar Gold Mines, 495; Electrical Equipment of Gold Mines, H. J. S. Heather, 575; Eruptive Diamond-bearing Breccias of the Boshof District, J. P. Johnson, 287; Auriferous Banded Ironstones and Associated Schists of South Africa, Owen Letcher, 287; the Vaal River Diamond Diggings, Mungo Park, 287; Mining Tables, Dr. F. H. Hatch and E. J. Valentine, 317; Mining in Nevada, 351; the Waste of Life in American Coal-mining, Clarence Hall and W. O. Snelling, 419; the Shaft Sinking at the Horden Colliery, South-east Durham, J. J. Prest, 420; Practical Coal Mining, 457; the High-level Platforms of Bodmin Moor and their Relation to the Deposits of Stream-tin and Wolfram, G. Barrow, 502; some Unsolved Problems in Metal-mining, "James Forrest" Lecture at Institution of Civil Engineers, Prof. Henry Louis, 619
- Miocene Wasp, a, Prof. T. D. A. Cockerell, 80

- Mira, the Maximum of, 1906, Naozo Ichinohe, 158
 Mira Ceti, the Recent Maximum of, Félix de Roy, 544
 Mirage, Theory of the, Prof. Antonio Garbasso, 356;
 Luigi Rolla, 356
 "Mirror, Magic," Effects, Douglas Carnegie, 55
 Mirrors, Temperature Control of Silvered, Dr. Heber D.
 Curtis, 137
 Missouri, Columbia, and Vicinity, Flora of, F. P. Daniels,
 29
 Mitton (G. E.), the Children's Book of Stars, 605
 Moffatt (C. W. P.), Science German Course, 53
 Molisch (Prof. Hans), die Purpurbakterien, 53
 Moll (Dr. J. W.), Handboek der botanische Micrographie,
 481
 Molluscs: the Dorsal Sense-organs of Chitons, Dr. M.
 Nowikoff, 135
 Monnier (Alfred), Traité de Chemie analytique qualitative,
 suivi de Tables systématiques pour l'Analyse minérale,
 437
 Monteverde (N. A.), the Absorption Spectrum of Proto-
 chlorophyll, 279
 Moodie (A. M.), Derivatives of Tetramethyl Glucose, 239
 Moog (Aug.), Influence of High Altitude on the Loss of
 Water by the Organism, 95
 Moon: Occultation of Neptune by the Moon, Dr. Downing,
 42; Investigation of Inequalities in the Motion of the
 Moon produced by the Action of the Planets, Prof. S.
 Newcomb and Frank E. Ross, 43; the Moon in Modern
 Astronomy, Ph. Fauth, W. E. Rolston, 195; Determina-
 tion of the Moon's Light with a Selenium Photometer,
 J. Stebbins and F. C. Brown, 258, 302; Observatory Map
 of the Moon, Mr. Porthouse, 544
 Moore (Prof.), the Equilibrium between the Cell and its
 Environment in Regard to Soluble Constituents, 399
 Morphology: Connection between Crocodiles and Sleeping
 Sickness, Prof. Koch, 16; the Cure and Prevention of
 Sleeping Sickness, 36; Proceedings of the First Interna-
 tional Conference on the Sleeping Sickness held at
 London, June, 1907, 440; New Method of Reaction of
 the Skin to Tuberculosis and its Utilisation in Diagnosis,
 J. Lignières, 23; Influence of Feeding on the Course of
 Experimental Tuberculosis, MM. Lannelongue, Achard,
 and Gaillard, 95; Malaria and Tuberculosis introduced
 into America by the White Man, Dr. Robert Hessler,
 231; Drapers' Company Research Memoirs, ii., a First
 Study of the Statistics of Pulmonary Tuberculosis, Prof.
 Karl Pearson, F.R.S., 394; Characters of Tuberculous
 Infection in their Relations with the Diagnosis of
 Tuberculosis, S. Arloing and L. Thévenot, 503; Sana-
 toria for Consumption, Dr. R. Fielding-Ould, 546; Rela-
 tions between Lecithin and Tubercle Bacilli and Tubercu-
 lin, A. Calmette, L. Massol, and M. Breton, 552;
 the Prevention of Malaria, Prof. Ronald Ross, 39;
 Malaria, a Neglected Factor in the History of Greece
 and Rome, W. H. S. Jones, 457; Therapeutics of
 Trypanosomes, A. Laveran and A. Thiroux, 47; Experi-
 mental Treatment of Trypanosomiasis in Rats, H. G.
 Plimmer and J. D. Thomson, 238; the Development of
 Trypanosomes in Tsetse-flies and other Diptera, Prof.
 E. A. Minchin, 494; Concerning *Trypanosoma congo-
 lense*, A. Laveran, 623; Plague and Fleas, 59; the Inter-
 dependence of the Rat and Plague, Dr. Ashburton
 Thompson, 113; Rats and Plague in India, Dr. W. C.
 Hossack, 205; Present Methods of combating Plague,
 Dr. Haffkine, 133; Protection of India from Plague,
 Dr. Ashburton Thompson, 133; Reports on Plague
 Investigations in India issued by the Advisory Committee
 appointed by the Secretary of State for India, the Royal
 Society and the Lister Institute, 585; Report on Plague
 in Queensland (February, 1900, to June 30, 1907), B.
 Burnett Ham, 585; the Etiology and Epidemiology of
 Plague, Major G. Lamb, 585; Bubonic Plague at San
 Francisco, 254; Experiments on Typhoid Fever Bacillus,
 Dr. Ravold, 60; Ship Beri-beri and Scurvy, Prof. Holst
 and Dr. Frölich, 113; an Essay upon Disease, its Cause
 and Prevention, Dr. G. E. Richmond, 365; the Diseases
 of Animals, Nelson S. Mayo, 436; the Disease of Dogs
 due to the Protozoan Parasite *Piroplasma canis*, Captain
 Christophers, 444
 Moreux (Abbé Th.), the Recent Transit of Mercury, 116
 Morgan (G. T.), Diazo-reaction in the Diphenyl Series,
 431
 Morphology: Vergleichende Morphologie der Pflanzen, Dr.
 Jos. Velenovsky, 76
 Morris (Sir D., K.C.M.G.), Disease-resisting Sugar-canes,
 438
 Morrow (Dr. J.), Lateral Vibration of Bars supported at
 Two Points with One End Overhanging, 119
 Mosaic Origin of the Atomic Theory, Dr. John Knott, 486
 Mosquitoes: the Prevention of Malaria, Prof. Ronald Ross,
 39; Chrysanthemum Powder as a Means of destroying
 Mosquitoes in Houses, Dr. A. L. Herrera, 278
 Moss (H.), Contact Potential Differences determined by
 Means of Nul Solutions, 477
 Moss (Richard J.), the Photoelectric Property of Selenium,
 198
 Moths of the British Isles, the, Richard South, 483
 Mott (Dr. F. W.), Localisation of Function in the Lemur's
 Brain, 501
 Mottier (Prof. D. M.), Some Scientific Centres, xii., the
 Botanical Institute of the University of Bonn, Prof. E.
 Strasburger, 321
 Mountaineering: Ascent of Trisul, Himalayas, 134; the
 Climber's Pocket Book, Rock-climbing Accidents, with
 Hints on First Aid to the Injured, some Uses of the
 Rope, Methods of Rescue and Transport, Lionel F.
 West, 166
 Moureu (Charles), Isosparteine, 216; Researches on the
 Rare Gases of Thermal Springs, 432
 Moussu (M.), Physiological Properties of Tubercle Bacilli
 which have been Submitted to the Action of Chlorine, 216
 Mudge (Geo. P.), the Interpretation of Mendelian Pheno-
 mena, 8
 Muirhead (R. F.), Simple Method of calculating First and
 Second Moments of Certain Elementary Figures, 88
 Mulattoes, Sir W. T. Thiselton-Dyer, K.C.M.G., F.R.S.,
 126; H. G. Wells, 149
 Müller (Bruno), the Air-sacs of Pigeons, 444
 Müller (Dr. C.), Light-emitting Plants, 542
 Müller (G.), Mikroskopisches und physiologisches Prak-
 tikum der Botanik für Lehrer, 481
 Müller (Sophus), l'Europe préhistorique, 578
 Mundella (V. A.), Educational Leakage, 617
 Muntz (A.), Utilisation of Turf for the Purification of
 Sewage, 287
 Muscle, Nerve as a Master of, Prof. C. S. Sherrington,
 F.R.S., at Royal Institution, 569
 Museums: Death of John MacLauchlan, 63; Best Means
 of preserving Marine Invertebrates for Museum Purposes,
 Dr. H. C. Sorby, 375
 Music and Melody, Prof. W. C. Sabine, 378
 Musical Sands, Cecil Carus-Wilson, 222, 271; Prof. J. H.
 Poynting, F.R.S., 248; Sidney Skinner, 248
 Mutation, Specific Stability and, Sir W. T. Thiselton-Dyer,
 K.C.M.G., F.R.S., 77, 127; R. H. Lock, 127
 Muusmann (P.), Meteors observed on January 2, 353
 Myres (Prof. John L.), an Early Notice of Neolithic
 Implements, 535
 Nagaoka (Prof. H.), Satellites of Yellow and Green Lines
 of Mercury, 581
 Nagaraja (Mr.), Weakened Lines in Sun-spot Spectra, 158
 Namalad and Kalahari, aus; Prof. Leonhard Schultze, Sir
 H. H. Johnston, G.C.M.G., 385
 Nansouty (Max de), Actuellement scientifiques, 437
 Natanson (L.), the Electromagnetic Theory of Dispersion
 in Gases, 352
 National Antarctic Expedition, 1901-4, 33
 National Decay, Malaria and, 457
 National Physical Laboratory during 1907, 521
 Natural History: National Antarctic Expedition, 1901-4,
 33; the Story of Scraggles (a Sparrow), George W.
 James, 77; the Egg of the Platypus, the Reviewer, 80;
 Linnean Society, 142, 190, 334, 406, 476, 527, 598; some
 Nature Biographies, Plant, Insect, Marine, Mineral,
 J. J. Ward, 147; the Fairyland of Living Things, R.
 Kearton, 147; on the Incidence of Daylight as a De-
 termining Factor in Bird-migration, Prof. E. A. Schäfer,
 F.R.S., 159; Science of Nature-history, Nasarvanji
 Jivanji Readymoney, 172; New South Wales Linnean
 Society, 192, 264; Newfoundland and its Untrodden

- Ways, J. G. Millais, 223; Plagues and Pleasures of Life in Bengal, Lieut.-Colonel D. D. Cunningham, 223; Report on Scenery Preservation for the Year 1906-7, Prof. Arthur Dendy, 297; Death of Morris K. Jesup, 298; Obituary Notice of Edward Bartlett, 325; Whose Home is in the Wilderness, some Studies of Wild Animal Life, W. J. Long, 393; Final Natural History Essays, Graham Renshaw, 393; Home-life of some Marsh-birds, Emma L. Turner and P. H. Bahr, 393; the *Raisonnement collectif* of Bees, Gaston Bonnier, 399; Nature and Development of Plants, C. C. Curtis, 436; Mimicry among South American Butterflies not connected with Birds, F. T. Lewis, 467; a Possible Case of Mimicry in the Common Sole, Dr. A. T. Masterman, 477; the Seashore, shown to the Children, Janet Harvey Kelman, Frank Balfour Browne, 533; the Dancing Mouse, a Study in Animal Behaviour, Robert M. Yerkes, 533; Animal Faculty of Orientation, Benjamin Kidd, 564; the Greater Horseshoe Bat in Captivity, T. A. Coward, 599; Development of the Rodent Mammals, 613; Natural History "Guide-books," the Elephant Group, Dr. C. W. Andrews, 613
- Nature and Nurture of the Child, 410
- Nature's Hygiene and Sanitary Chemistry, C. T. Kingzett, 100
- Naval Architecture, a Contribution to the Study of Iron-clads, Lord Rosse, 356; Researches on the Performance of the Screw Propeller, Prof. W. F. Durand, 416; the Substitution of Cement for Steel in the Armour of Battleships, Lorenzo d'Adda, 543; Trial of H.M.S. *Tartar*, 614
- Navigation: Visibility of Night Signals at Sea, André Broca and M. Polack, 95; Apparatus for extinguishing the Rolling of Ships, Dr. Victor Cremieu, 114; the Electric Propulsion of Ships, H. A. Mavor, 543
- Navigation of the Air, 562
- Nebula, Parallax of the Andromeda, Dr. Karl Bohlin, 446
- Nebule and Nebulosity observed by Prof. Barnard, 497
- Nebule, Surveys of, P. Gutz, 90
- Nelson (T. H.), the Birds of Yorkshire, 511
- Neogenesis, Italian Birds and, 25
- Neolithic Dew-ponds and Cattle-ways, Dr. Arthur John Hubbard and George Hubbard, W. E. Rolston, 245
- Neolithic Implements, an Early Notice of, Prof. John L. Myers, 535
- Neptune, Occultation of, by the Moon, Dr. Downing, 42
- Neptune, the Appearance of, in Small Telescopes, Mr. Holmes, 258; Mr. Maw, 258
- Nernst (Dr. Walther), Experimental and Theoretical Applications of Thermodynamics to Chemistry, 52
- Nerve as a Master of Muscle, Prof. C. S. Sherrington, F.R.S., at Royal Institution, 569
- Nerz (F.), Searchlights, their Theory, Construction, and Application, 460
- Nest Eggs of Platypus, Prof. Gregg Wilson, 149
- Nests and Eggs of Birds found Breeding in Australia and Tasmania, A. J. North, 76
- Neumann (B.), *Traité complet d'Analyse chimique appliquée aux Essais industriels*, 531
- Neurology: the Nervous System of Vertebrates, Prof. J. B. Johnston, Dr. W. Page May, 73; Nerve as a Master of Muscle, Prof. C. S. Sherrington, F.R.S., at Royal Institution, 569
- "New Jerusalem," a Lunar, Rev. G. B. Berry, 163
- New South Wales Linnean Society, 192, 264
- New South Wales Royal Society, 23, 263, 479
- New Zealand: Report on Scenery Preservation for the Year 1906-7, Prof. Arthur Dendy, 297; Report on a Botanical Survey of Kapiti Island, L. Cockayne, Prof. Arthur Dendy, 297
- Newall (H. F.), Spectroscopic Observations of Cyanogen in the Solar Atmosphere and in Interplanetary Space, 94
- Newcomb (Prof. S.), Investigation of Inequalities in the Motion of the Moon produced by the Action of the Planets, 43
- Newfoundland and its Untrodden Ways, J. G. Millais, 233
- Newsholme (Dr. Arthur), Alcohol and the Human Body, 587
- Newstead (R.), the Habits, Life-history, and Breeding-places of the House-fly, 135
- Newton's "Principia," an Annotated Copy of, Bruce Smith, 510; W. R. B. Prideaux, 534
- Newton's Rings in Polarised Light, P. V. Bevan, 9
- Nicholls (George E.), Reissner's Fibre in the Frog, 344
- Nichols (H. G.), Method of Settling Slimes as Applied to their Separation from Solution in Cyanide, 406
- Nicholson (Dr. J. W.), Inductance in Parallel Wires, 295
- Niclioux (Maurice), Ethyl Chloride in the Blood during Anaesthesia, 240
- Nietzsche in Outline and Aphorism, A. R. Orage, 173
- Nietzsche (Friedrich), Beyond Good and Evil, Prelude to a Philosophy of the Future, 460
- Nile, the Fishes of the, G. A. Boulenger, F.R.S., 10
- Nile, a Description of the First or Aswan Cataract of the, Dr. John Ball, 433
- Nitre Beds, Modern, 513
- Nitrous Oxide, the "Histoire Intime" of, 434
- Nobbs (Dr.), Work to be done at the Experiment Stations at Kynsna and Robertson, Cape Colony, 64
- Noble (Margaret E.), Cradle Tales of Hinduism, 605
- Nordmann (Dr. C.), the Dispersion of Light in Interstellar Space, 497; Variable Star Observations, 520
- Norman (G. M.), Systematic Practical Organic Chemistry, 74
- North (A. J.), Nests and Eggs of Birds found Breeding in Australia and Tasmania, 76
- North Sea Fisheries Investigations, the, Frank Balfour Browne, 523
- Nova Persei, 1901, Prof. Barnard, 182
- Nova Persei, No. 2, the Recent Spectrum and Magnitude of, Prof. Hartmann, 377
- Nova Velorum, Red Stars near, Mrs. Fleming, 42
- November Meteors, John R. Henry, 31
- Nowikoff (Dr. M.), the Dorsal Sense-organs of Chitons, 135
- Noyes (Arthur A.), the Electrical Conductivity of Aqueous Solutions, 213
- Noyes (W. A.), Re-determination of the Atomic Weight of Chlorine, 543
- Nunn (Dr. Percy T.), the Place of Nature-study in the School Curriculum, 282
- Nyassa, the Oligochaetous Fauna of Lake Birket et Qurun and Lake, Frank E. Beddard, F.R.S., 608
- O'Farrell (H. H.), the Interpretation of Mendelian Phenomena, 271
- O'Neil (J. J.), Inter-relation of the Theory and Practice of Shipbuilding, 327
- Objective Prism in Solar Spectroscopy, the, E. Schaer, 401
- Observatories: the Hamburg Observatory, Prof. Schorr, 544; Observatory Map of the Moon, Mr. Porthouse, 544; the Harvard College Observatory, Prof. Pickering, 567; Determination of the Errors of the Paris Observatory Réseaux, Jules Baillaud, 617
- Occultations of Uranus in 1908, Dr. Downing, 353
- Oceanic Languages, the, their Grammatical Structure, Vocabulary, and Origin, Dr. D. Macdonald, 460
- Oddone (Dr. E.), Possibility of a Causal Connection between the two Earthquakes on August 16, 1906, in the Northern Pacific and in Chile, 468
- Ogily (J. W.), Microscopes of New Design made by Messrs. Leit, 311
- Oka (Dr. Asajiro), *L. kawaii*, new Chinese Fresh-water Medusa, 398
- Oldham (C.), Birds of the Ravensglass Gully, 1906, 623
- Oldham (F. M.), the Complete School Chemistry, 74
- Oldham (R. D.), the Winding of Rivers in Plains, 55; Seismographs and Seismograms, 246
- Olie (J.), the so-called Amorphous Antimony and Bismuth, 352
- Oligochaetous Fauna of Lake Birket et Qurun and Lake Nyassa, the, Frank E. Beddard, F.R.S., 608
- Olivier (C. P.), Measures of Double Stars, 281
- Olmsted (Charles M.), Sun-spot Spectra, 421
- Onnes (Prof. H. Kamerlingh), Variation of the Electrical Resistance of Pure Metals Down to Very Low Temperatures, 233; Helium Solidified, 442; Absorption Spectra of Crystals of the Rare Earths in a Magnetic Field at the Temperatures of the Liquefaction and Solidification of Hydrogen, 527; the Condensation of Helium, 559, 581

- Oort (Dr. E. D. van), New Cassowary from New Guinea, 504
- Optics: Newton's Rings in Polarised Light, P. V. Bevan, 9; an Optical Illusion, Dr. L. U. H. C. Werndly, 31; "Magic Mirror" Effects, Douglas Carnegie, 55; the Permanency of some Photovisual Lenses, Dr. W. J. S. Lockyer, 94; Correction of the Astigmatism of Doubly Refracting Prisms, C. Tissot and Félix Pellin, 95; Reflection of Polarised Light, C. T. Whitmell, 103; zur vergleichenden Physiologie des Gesichtsinnes, Prof. E. Raehlmann, 193; Phosphorescence at Low Temperatures, Joseph de Kowalski, 215; the Production of Chlorophyll in the Higher Plants at Different Luminous Intensities, W. Lubimenko, 216; Influence of Temperature on the Optical Properties of Dissolved Bodies, C. Chéneveau, 216; an Exceptional Case of Zeeman's Phenomenon, A. Dufour, 311; Specimens of Luminous Bacteria, J. E. Barnard, 311; Theory of the Mirage, Prof. Antonio Garbasso, 356; Luigi Rolle, 356; Searchlights: their Theory, Construction, and Application, F. Nerz, 460; Perception of Relief and of Depth in the Simple Image of Ordinary Photographs, A. Chauveau, 576; Apparatus for demonstrating the Action of Light on Selenium, J. W. Giltay, 589; die binokularen Instrumente, Moritz von Rohr, Supp. to March 5, iv
- Orbit (A. K.), Nietzsche in Outline and Aphorism, 173
- Orbit of 7 Virginis, the, Dr. Doberck, 446; Orbits of Spectroscopic Binaries, Dr. Curtis, 138
- Organic Chemistry for Advanced Students, Prof. J. B. Cohen, 363
- Orientation of the Aveyru Circles, Rev. Ed. H. Goddard, 320
- Ornithology: Avifauna Italica, Enrico Hillyer Giglioli, 25; Irish Nesting-colony of Red-necked Phalaropes, H. S. Gladstone, 63; Nests and Eggs of Birds found breeding in Australia and Tasmania, A. J. North, 76; Wanton Slaughter of Egrets, A. H. Mattingley, 87; the Birds of North and Middle America, R. Ridgway, 91; Bird-life of the Borders, on Moorland and Sea, with Faunal Notes extending over Forty Years, Abel Chapman, 122; the Birds of Kent, William J. Davis, 122; Notes on the Birds of Rutland, C. Reginald Haines, 122; Muscles of the Head in Birds and Reptiles, Prof. H. F. Edgeworth, 155; Structure of the Roof of the Mouth in Birds and Mammals, Dr. W. Sippel, 155; Luminous Owl, Sir T. Digby Pigott, 155; the Luminous Owl seen in Norfolk, Sir T. Digby Pigott, 205; Luminous Barn-owls, Miss L. L. Veley, 209; Luminous Owls, 375; Rate of Growth of Ostrich Feathers, Prof. Duerden, 180; the Carnivorous Habits of the Kea, Prof. W. B. Benham, 205; G. R. Marriner, 205; Album de Aves Amazonicas, Dr. E. A. Goeldi, 220; the Californian Condor, W. L. Finley, 255; the "Waltzing Instinct" in Ostriches, Dr. J. E. Duerden, 278; Home-life of some Marsh-birds, Emma L. Turner and P. H. Bahr, 393; Growth and Development of the Limbs of the Penguin, Dr. D. Waterston and A. C. Geddes, 407; the Inheritance of Colour in Domestic Pigeons, with Special Reference to Reversion, R. Staples-Brown, 430; the Air-sacs of Pigeons, Bruno Müller, 444; the Geographical Variation in Birds, Effects of Climatic Humidity, C. W. Beebe, 553; Bird-bones from Broch of Ayre, Orkney, N. F. Ticehurst, 467; "the Policemen of the Air," H. W. Henshaw, 493; a British Willow-titmouse, H. B. Booth, 493; the Birds of Yorkshire, T. H. Nelson, W. Eagle Clark, and F. Boyes, 511; Notes on the Birds of Kent, R. J. Balston, Rev. C. W. Shepherd, and E. Bartlett, 511; the Food of American Birds, W. L. McAtee, 564; New Cassowary from New Guinea, Dr. E. D. van Oort, 564; Spread of the Little Owl in England, Messrs. Witherby and Ticehurst, 564; the Seasonal Colour-change in Birds, C. W. Beebe, 564; Birds of the Ravenglass Gully, 1906, C. Oldham, 623
- Osborn (H. F.), Evolution of Mammalian Molar Teeth, to and from the Triangular Type, 435
- Osgood (Dr. W. F.), a First Course in the Differential and Integral Calculus, 577
- Osteology: Studies in the Medicine of Ancient India, Dr. A. F. Rudolf Hoernle, C.I.E., 533; Musée ostéologique; Etude de la Faune quaternaire, Ostéométrie des Mammifères, E. Hue, 604
- Ostrich Feathers, Rate of Growth of, Prof. Duerden, 180
- Ottley (Sir John W., K.C.I.E.), Stresses in Masonry Dams, at Institution of Civil Engineers, 303
- Pace (Miss L.), Fertilisation in the Genus *Cypripedium*, 300
- Pacific Ocean, the Bed of the Western, 21
- Palaeobotany: the Cretaceous Flora of Southern New York and New England, Arthur Hollick, 121; (1) the Cone of *Bothrodendron muudum* (Willk.), (2) on the Ulodendroid Scar, Dr. M. S. Watson, 191; Fossil *Osmondaceae*, D. T. Gwynne-Vaughan and R. K. Idston, F.R.S., 311; *Lepidophloios Scotti*, W. T. Gordon, 431; the Structure of *Stigillaria scutellata*, E. A. Newell Arber and Hugh H. Thomas, 549
- Palaeolithics: Small Flint Implements from Bungay, W. A. Dutt, 102; Recent Discoveries of Palaeolithic Implements, Sir John Evans, 214; Eolith Stone Implements, Worthington Smith, 615
- Palaeontology: les Formations sédimentaires du Crétacé Supérieur et du Tertiaire de Patagonie, avec un Parallèle entre leur Faunes mammalogiques et celles de l'ancien Continent, Florentino Ameghino, 68; a Miocene Wasp, Prof. T. D. A. Cockerell, 80; *Tetraprothomo argentinus* from the later Tertiary Deposits of Monte Hermosa, Dr. F. Ameghino, 113; Lower Palaeozoic Fossils of the Northern Shan States, Burma, F. R. Cower Reed, 116; Fauna of the Tropites Limestone of Byans, South-west Himalayas, Dr. Carl Diener, 116; the Primary Hexamerous Character of Rugose Corals, *Streptelasma rectum*, T. C. Brown, 117; Genera of *Crimoidea flexibilia*, Frank Springer, 117; Examples found in the Neocomian, Dr. A. Till, 184; Revision of the Pelycosauria of North America, E. C. Case, 186; the Systematic Position of the Chalicotherioids, O. A. Peterson, 399; *Metricorynchus brachyrhynchus*, Deslong., from the Oxford Clay near Peterborough, E. T. Leeds, 502; Lamellibranch Fauna in the Millstone Grit of Scotland and the Silurian Rocks of Girvan, Dr. Wheelton Hind, 551; Einführung in die Paläontologie, Gustav Steinmann, 558; Musée ostéologique; Etude de la Faune quaternaire, Ostéométrie des Mammifères, E. Hue, 604
- Palazzo (Prof. L.), I brontidi del Bacino Bolsenese, Barisal Guns, 236
- Palmer (Frederic, jun.), Ionisation of Air by Ultra-violet Light, 582
- Palmer (G. W.), Arithmetic, chiefly Examples, 27
- Paper-making, Chapters on, Clayton Beadle, 121
- Parallax of the Andromeda Nebula, Dr. Karl Bohlin, 446
- Parallax Observations, Dr. Karl Bohlin, 567
- Parasitology: das Schmarotzertum im Tierreich und seine Bedeutung für die Artbildung, Prof. Ludwig von Graff, 556
- Paris Academy of Sciences, 23, 47, 95, 119, 167, 215, 239, 263, 287, 311, 335, 359, 383, 407, 431, 455, 479, 503, 527, 551, 575, 600, 623; Prizes awarded by the, 138; Prizes proposed by the, for 1909, 183
- Paris Observatory Réseau, Determination of the Errors of the, Jules Baillaud, 617
- Park (Mungo), the Vaal River Diamond Diggings, 287
- Parker, (Mr.), Potomac River Basin, 68
- Parkhurst (J. A.), Absolute Scale of Photographic Magnitudes, 208
- Parkinson (J.), Petrology and Physiography of Western Liberia, 527
- Parr (Prof. S. W.), the Weathering of Coal, 468
- Parsons (Mr.), Discovery of Thorianite in Ceylon, 185
- Parsons (Hon. C. A., C.B., F.R.S.), the Conversion of Diamond into Coke in High Vacuum by Kathode Rays, 549
- Partridge (William), the Bacteriological Examination of Disinfectants, 246
- Pascal (P.), Complex Salts of Iron in which the Iron is masked, 359; Reducing Power of Ferropyrophosphates, 623
- Pascoe (E. H.), Glaciers in Lahaul, 201
- Patagonie, les Formations sédimentaires du Crétacé Supérieur et du Tertiaire de, avec un Parallèle entre leur Faunes mammalogiques et celles de l'ancien Continent, Florentino Ameghino, 68

- Paternò (Prof. E.), the Origin of Stereochemistry, 328
 Pathology: Inflammation, an Introduction to the Study of Pathology, Prof. J. George Adams, Prof. R. T. Hewlett, 126; Tendencies in Pathology, Dr. Simon Flexner, 379
 Patrick (David), Gods and Godlings, 402
 Patroclus, Elements and Ephemeris for the Minor Planet, V. Heinrich, 67
 Patterson (J. W.), Colour Photographs of Rock Sections, 200
 Pawlowsky (E.), Structure of the Epidermis and Epidermal Glands of Poisonous Fishes, 613
 Peach (B. N.), the Geological Structure of the North-west Highlands of Scotland, 272
 Pearl in "Window-pane Oyster," Ceylon, Dr. A. Willey, 326
 Pearl Fishing, Radiography in, John J. Solomon, 331
 Pearce (L. E. B.), the Assay of Telluride Ores, 190
 Pearson (Prof. H. H. W.), the Botany of Walfish Bay, 40
 Pearson (Prof. Karl, F.R.S.), an Experimental Study of Stresses in Masonry Dams, 209; the Stresses in Masonry Dams, 269, 366; Drapers' Company Research Memoirs, ii., a First Study of the Statistics of Pulmonary Tuberculosis, 304; Mendelian Characters among Shorthorns, 559
 Peat Utilisation, 114
 Peculiarities in the Structure of some Heavenly Bodies, Prof. Suess, 490
 Pellat (H.), Cours d'Électricité, 458
 Pellin (Félix), Correction of the Astigmatism of Doubly Refracting Prisms, 95
 Pelly (R. G.), New Isomeride of Vanillin in the Root of Chlorocodon, 502; Volatile Oils of the Leaves of *Ocinum viride*, 502
 Pelycosauria of North America, Revision of the, E. C. Case, 186
 Pendulations-theorie, die, Dr. Heinrich Simroth, 508
 Penrose's Pictorial Annual, 1907-8, 202
 Perkin (Dr. F. Mollwo), Reduction of Metallic Oxides with Calcium Hydride and Calcium, 47; the Metric and British Systems of Weights, Measures, and Coinage, 77; the Discovery of the Alkali Metals by Davy, 214; Action of Metallic Calcium on Alcohols, 239
 Perkin (W. H.), Synthesis of Brazilin Acid, 166; Synthesis of Anhydrobrazilin Acid, 431
 Perman (Prof. E. P.), Decomposition of Ozone by Heat, 574
 Perrier (G.), Formation of Mixtures of Isomers of Constant Melting Point in the Friedel and Crafts Reaction, 576
 Perry (Prof. John, F.R.S.), Practical Mathematics, 6; the Speed of Racing Animals, 389; the Use of Gyrostats, Discourse at Physical Society, 447
 Persei, Nova, 1901, Prof. Barnard, 182
 Persei, Nova, No. 2, the Recent Spectrum and Magnitude of, Prof. Hartmann, 377
 Perspective Drawing, the Theory and Practice of, S. Polak, 411
 Petavel (J. E.), Meteorological Observations at the British Kite Station, Session 1906-7, 188
 Petch (T.), Stem Disease caused by *Massaria-theicola*, 326
 Peterson (O. A.), the Systematic Position of the Chalciotherioids, 399
 Petrie (Dr. J. M.), Solandrine, New Midriatic Alkaloid, 192
 Petrography: Death of Dr. H. C. Sorby, F.R.S., 443; Obituary Notice of, 465; National Antarctic Expedition, 1901-4, Petrography, Dr. Prior, 561
 Petronievics (B.), die typischen Geometrien und das Unendliche, 28
 Petrunkevitch (Dr. Alexander), the Sense of Sight in Spiders, 350
 Pettigrew (Prof. J. B., F.R.S.), Death of, 324; Obituary Notice of, 348
 Pfeiffer (Miss W. F.), Early Stages of Development of the Sporangia and the Sporocarps of Azolla, 517
 Pharmacy: Pharmakognostisches Praktikum, Dr. Ludwig Koch and Dr. Ernst Gilg, 508
 Philip (Alex.), a Simplified Calendar, 479
 Philip and Son (Messrs.), the "Day by Day" Tellurian, 157
 Philippine Woods, Commercial, F. W. Foxworthy, 390
 Phillips (Charles E. S.), Coloration of Glass and Quartz by Radium, 535
 Phillips (H. A.), the Metallic Pterates, 383
 Phillips (Rev. T. E. R.), Saturn's Rings, 234
 Philosophy: Éléments de Philosophie biologique, Félix le Dante, 51; the Case of Existence, Norman Alliston, 53; Cambridge Philosophical Society, 167, 190, 454, 478, 503; Nietzsche in Outline and Aphorism, A. R. Orage, 173; Proceedings of the Aristotelian Society, 290; Beyond Good and Evil, Prelude to a Philosophy of the Future, Friedrich Nietzsche, 460; the Will to Doubt, an Essay in Philosophy for the General Thinker, Alfred H. Lloyd, 534
 Phebe, Micrometer Observations of, Prof. Barnard, 421
 Phonetics: the Mechanism of Speech, Alexander Graham Bell, Prof. John G. Kendrick, F.R.S., 483
 Photoelectric Property of Selenium, the, Prof. George M. Minchin, F.R.S., 173, 222; Richard J. Moss, 198; Dr. Shelford Bidwell, F.R.S., 198
 Photographs of the Year 1907, 293
 Photography: the Improvement of Celestial Photographic Images, Prof. Lowell, 42; Photographs of Jupiter, M. Quénet, 90; Photographs of Jupiter's Satellites VI. and VII., 137; the British Journal Photographic Almanac and Photographer's Daily Companion for 1908, 172; Photographs of Mars, Prof. Lowell, 182; Photographic Plates prepared by the Lumière Starch-grain Process for Colour Photography, Conrad Beck, 188; Colour Photographs of Rock Sections, J. W. Patterson, 206; Absolute Scale of Photographic Magnitudes, J. A. Parkhurst and F. C. Jordan, 208; Photographic Observations of Encke's Comet (1908A), Prof. Wolf, 302; the Distortion of Photographic Films in Stellar Work, Dr. Frank Schlesinger, 328; Planetary Photography, Prof. Percival Lowell, 402; a New Method of Stereoscopic Photography, Prof. G. Lippmann, 452; les Progrès de la Photographie astronomique, Prof. P. Stroobant, 508; Photography of the Vibrations of the Voice, M. Marage, 527; Method of Photographing the Vibrations of a Thin India-rubber Membrane acted on by the Human Voice, Dr. M. Marage, 589; Astronomical Photography with Portrait Lenses, Prof. Barnard, 567
 Photometer, Determination of the Moon's Light with a Selenium, J. Stebbins and F. C. Brown, 258, 302
 Photosphere, a Detailed Study of the, Mr. Chevalier, 378
 Physical Geography: Land Erosion by Storm Water in Cape Colony, 351; Physiographical Experiments on the Aggrading and Degrading Stream, 351
 Physics: Scientific Worthies, Sir William Crookes, F.R.S., Prof. P. Zeeman, 1; la Théorie de la Physique chez les Physiciens contemporains, Abel Rey, 6; Technische Anwendungen der physikalischen Chemie, Dr. Kurt Arndt, 32; the Wehnelt Kathode in a High Vacuum, Prof. Frederick Soddy, 53, 197; Prof. O. W. Richardson, 197; Physical Society, 71, 118, 188, 382, 453, 477, 593, 575; Freehand Graphic Way of determining Stream Surfaces and Equipotentials, L. F. Richardson, 118; Lateral Vibration of Bars supported at Two Points with One End Overhanging; Dr. J. Morrow, 119; Death and Obituary Notice of Prof. Alfonso Sella, 133; Exhibition of Physical Apparatus, 139; Condensation of Water Vapour in the Presence of Radium Emanation, Mme. Curie, 167; Obituary Notice of Lord Kelvin, Prof. Silvanus P. Thompson, F.R.S., 175; Lord Kelvin's Funeral in Westminster Abbey, 177; Lord Kelvin, an Appreciation, 199; Lord Kelvin and the University of Glasgow, 200; a Micromanometer, L. Baird, 188; Singing Sand from New England, S. Skinner, 188; Musical Sands, Cecil Carus-Wilson, 222, 271; Prof. J. H. Poynting, F.R.S., 248; Sidney Skinner, 248; Manganese Chloride as Fixed Point in Thermometry, T. W. Richards and Franz Wrede, 207; the Cryoscopic Behaviour of Sulphuric Acid, A. Hantsch, 207; the Audiffren Refrigerator, MM. Audiffren and Singrün, 215; the Polarity of Matter, Alex. Clark, 219; das Problem der Schwingungserzeugung, Dr. H. Barkhausen, 220; Recent Determinations of the Volume of the Kilogram of Water, René Benoit, 239; an Early Acoustical Analogue of Michelson's Echelon Grating, Prof. P. Zeeman, 247; Van Nostrand's Chemical Annual, 1907, 267; die Physik Roger Bacos, Sebastian Vogl, 268; the Dimensions of Space, 280; Electrical Phenomena of the Atmosphere and their Relations with Solar Activity, Prof. Schuster, 301; Leçons sur la Viscosité des Liquides et des Gaz, Marcel Brillouin, 441; Posidonius on the Originator of the Theory of Atoms, Dr. T. J. J. See,

345; an Alleged Originator of the Theory of Atoms, Dr. J. L. E. Dreyer, 368; Mosaic Origin of the Atomic Theory, Dr. John Knott, 486; on the Physical Aspect of the Atomic Theory, Wilde Lecture of Manchester Literary and Philosophical Society, Prof. J. Larmer, Sec.R.S., 450; the Electromagnetic Theory of Dispersion in Gases, L. Natanson, 352; New Type of Dynamical Stability, A. Stephenson, 359; Formation of Gas Bubbles in the Glass of Vacuum Tubes, A. A. Campbell Swinton, 374; Recalescence Curves, W. Rosenhain, 382; die Zustands-gleichung der Gase und Flüssigkeiten und die Continuitätstheorie, Prof. J. P. Kuenen, 387; the Lines of Flow of Water in Saturated Soils, especially Peat-mosses, L. F. Richardson, 407; a Fundamental Con- traction between the Electrical Theory of Dispersion and the Phenomena of Spectrum Series, Dr. G. A. Schott, 413; Report of the Committee on the National Physical Laboratory, 417; National Physical Laboratory during 1907, 521; Further Consideration of the Stability of the Pear-shaped Figure of a Rotating Mass of Liquid, Sir G. H. Darwin, K.C.B., F.R.S., 430; Influence of Sun- light on the Disengagement and on the Orientation of the Gaseous Molecules in Solution in Sea-water, Raphael Dubois, 431; the Use of Gyrostats, Prof. J. Perry, F.R.S., at Physical Society, 447; les Découvertes modernes en Physique, O. Manville, 458; the Viscosity of Water at Very Low Rates of Shear, L. E. Gurney, 470; Experimental Examination of Gibbs's Theory of Surface Concentration regarded as the Basis of Absorp- tion and its Application to the Theory of Dyeing, W. C. M. Lewis, 477; the New Matriculation Heat, 482; the New Matriculation Light, 482; the New Matricula- tion Sounding, 482; a First Year's Course in Geometry and Physics, Ernest Young, 482; a Second Year's Course in Practical Physics, James Sinclair, 482; a Third Year's Course in Practical Physics, James Sinclair, 482; Determination of Viscosity at High Temperatures, Dr. C. E. Fawcitt, 502; Certain Dynamical Analogues of Tempera- ture Equilibrium, Prof. G. H. Bryan, 503; Velocity of Evaporation and a Method of determining the Hygro- metric State, P. Vaillant, 503; the Corpuscular Theory of Matter, Prof. J. J. Thomson, F.R.S., 505; Diffusion and Osmosis, Prof. Stéphane Leduc, 519; an Annotated Copy of Newton's "Principia," Bruce Smith, 510; W. R. B. Prideaux, 534; Handbuch der Physik, Dr. A. Winkelmann, 559; the Plug Permeameter, Dr. C. V. Dreydale, 575; Lehrbuch der Physik, Prof. H. A. Lorentz, 580; l'Énergétique et le Mécanisme au Point de Vue des Conditions de la Connaissance, Abel Rey, 580; Ionisation of Air by Ultra-violet Light, Frederic Palmer, jun., 582; Lehrbuch der medizinischen Physik, Prof. H. Boruttua, 604; the Radio-activity of Ordinary Metals, the Penetrating Radiation from the Earth, Prof. J. C. McLennan, 607; Scottish National Antarctic Ex- pedition, Report on the Scientific Results of the S.Y. *Scotia* during the Years 1902, 1903, and 1904, under the Leader- ship of W. S. Bruce, Vol. ii., Physics, 618

Physiography: de Vormen der Aardkorst, Inleiding tot de Studie der Physiographie, J. van Baren, 76; Physiog- raphical Experiments in Aggrading and Degrading Stream, 351; Physiography, Prof. R. D. Salisbury, Supp. to March 5, v

Physiology: Mechanism of the Transformation of Glycogen into Glucose by the Muscles and the Animal Tissues, F. Maignon, 23; the Physiology of Alimentation, Prof. Martin H. Fischer, 26; the Sugar in the Blood Plasma, R. Lepiné and M. Boulud, 47; Life-history of Leucocytes, Part ii., on the Origin of the Granules, Part iii., Phenomena occurring in Leucocytes, C. E. Walker, 71; Influence of High Altitude on the Loss of Water by the Organism, H. Guillemand and Aug. Moog, 95; Orga- nische Zweckmässigkeit, Entwicklung und Vererbung von Standpunkte der Physiologie, Dr. Paul Jensen, 100; Physiologisches Praktikum für Mediziner, Prof. Max Verworn, 148; on the Incidence of Daylight as a Deter- mining Factor in Bird-migration, Prof. E. A. Schäfer, F.R.S., 159; Distribution of Arteries supplying the Human Brain, Dr. C. E. Beavor, 187; Influence of Increased Barometric Pressure on Man, Leonard Hill, F.R.S., and M. Greenwood, jun., 187; zur vergleichenden Physiologie des Gesichtssinnes, Prof. E. Raehmann, 193;

the Excito-secretory Action of the Internal Branch of the Spinal Nerve on the Stomach and Pancreas, F. X. Lesbre and F. Maignon, 216; Physiological Properties of Tubercle Bacilli which have been submitted to the Action of Chlorine, M.M. Moussu and Goupil, 216; a Manual of Veterinary Physiology, Colonel F. Smith, C.B., C.M.G., Dr. Percy T. Herring, 219; Ethyl Chloride in the Blood during Anæsthesia, Lucien Camus and Maurice Nicloux, 240; Structure of the Fundamental Substance of Hyaline Cartilage, Ed. Retterer, 263; Action of Choline on the Arterial Pressure, A. Desgrez and J. Chevalier, 288; Arterial Pressure in Man, Dr. G. A. Gibson, 335; the Prolongation of Life, Elie Metchnikoff, 289; Reciprocal Innervation of Antagonistic Muscles, Prof. C. S. Sherrington, F.R.S., 333; Attempt at Grafting Articular Tissues, Henri Judet, 336; Reissner's Fibre in the Frog, George E. Nicholls, 344; the Equilibrium between the Cell and its Environment in Regard to Soluble Constituents, Prof. Moore and Dr. Roaf, 399; the Middle Cells of the Grey Matter of the Spinal Cord, Dr. J. H. Harvey Pirie, 431; Physiologie und Anatomie des Menschen mit ausblicken auf den ganzen Kreis der Wirbeltiere, Dr. Felix Kienitz-Gerloff, 484; Excitability and Conductibility of Nerves exposed to the Action of Distilled Water, W. K. Denmark, 498; Localisation of Function in the Lemur's Brain, Dr. F. W. Mott and Prof. W. D. Halliburton, F.R.S., 501; Asymmetry of the Figure and its Origin, Richard Liebreich, 503; die Mechanik des Geisteslebens, Prof. Max Verworn, 556; Nerve as a Master of Muscle, Prof. C. S. Sherrington, F.R.S., at Royal Institution, 569; the Influence of Inanition on Metabolism, Francis Gano Benedict, 610; Comparative Electro-physiology, Prof. J. C. Bose, Supp. to March 5, iii; Plant Physiology, Immunity to Disease among Plants, Prof. F. E. Weiss at British Pharmaceutical Conference at Manchester, 20; Lectures on Plant Physiology, Prof. Ludwig Jost, 97; der Einfluss des Klimas auf den Bau der Pflanzengewebe, Anatomisch-physiologische Untersuchungen in den Tropen, Dr. Carl Holtermann, 313

Pickard (R. H.), Resolution of *sec*-Octyl Alcohol, 166

Pickering (Prof.), the Harvard College Observatory, 567; Spectroscopic Binaries now under Observation, 590

Pickering (S.), Emulsions, 143; Interaction of Metallic Sulphates and Caustic Alkalies, 143; Chemistry of Bordeaux Mixtures, 143

Pickering (Mr.), Investigation of the Washes for spraying Fruit Trees, 590

Pictorial Annual, Penrose's, 1907-8, 292

Pidoux (M.), the Transit of Mercury, November, 1907, 567

Pigott (Sir T. Digby), Luminous Owl, 155; the Luminous Owl seen in Norfolk, 205

Pilze, Chemie der höheren, eine Monographie, Dr. Julius Zellner, Prof. R. Meldola, F.R.S., 553

Pionchon (J.), an Extremely Sensitive Electric Hygroscope, 600

Pirie (Dr. J. H. Harvey), the Middle Cells of the Grey Matter of the Spinal Cord, 431

Pirrie (Dr. A. M.), Death and Obituary Notice of, 62

Pisciculture: Marine Fish-culture in United States, G. M. Bowers, 179

Plague: Plague and Fleas, 50; the Interdependence of the Rat and Plague, Dr. Ashburton Thompson, 113; Rats and Plague in India, Dr. W. C. Hossack, 205; Present Methods of Combating Plague, Dr. Haifkine, 133; Protection of India from Plague, Dr. Ashburton Thompson, 133; Bubonic Plague at San Francisco, 254; Reports on Plague Investigations in India issued by the Advisory Committee appointed by the Secretary of State for India, the Royal Society and the Lister Institute, 585; Report on Plague in Queensland (February, 1900-June 30, 1907), B. Burnett Ham, 585; the Etiology and Epidemiology of Plague, Major G. Lamb, 585

Plagues and Pleasures of Life in Bengal, Lieut.-Colonel D. D. Cunningham, 223

Planer (V.), Comparison of the Energy Losses due to Hysteresis in Iron, Steel, and Nickel, in Alternating and Rotating Magnetic Fields respectively, 327

Planetary Photography, Prof. Percival Lowell, 402

Planets: the Transit of Mercury, M. Bigourdan, 18; the Recent Transit of Mercury, M.M. Javelle and Simonin,

- 116; M. Charlois, 116; M. Bourget, 116; M. Borrelly, 116; M. Esmiol, 116; Abbé Th. Moreux, 116; Comte de la Baume Pluvinel, 116; the Transit of Mercury, November, 1907, M. Gautier, 567; M. Pidoux, 567; Mercury as a Morning Star, 113; Changes on Saturn's Rings, Prof. Campbell, 18; Saturn's Rings, Dr. Ristenpart, 67; Prof. Hartwig, 67; Prof. Lowell, 67, 116, 616; Paul Guthnick, 67; Prof. B. Peter, 90; M. Schær, 90; Dr. Hasenstein, 90; Rev. T. E. R. Phillips, 234; Dr. Lau, 234; Prof. Barnard, 401; Mr. Lampland, 616; Saturn apparently without Rings, M. Flammarion, 182; Saturn, a New Ring suspected, G. Fournier, 302; the Saturn Perturbations of various Comets, Dr. Johannes Wenzel, 568; Occultation of Neptune by the Moon, Dr. Downing, 42; the Appearance of Neptune in small Telescopes, Mr. Holmes, 258; Mr. Maw, 258; the Great Red Spot on Jupiter, Mr. Denning, 42; Photographs of Jupiter, M. Quézisset, 90; Photographs of Jupiter's Satellites VI. and VII., 137; Simultaneous Observations of Jupiter, Jean Mascart, 259; Uniformly Distributed dark Spots on Jupiter, Scriven Bolton, 401; a Possible New Satellite to Jupiter, P. Melotte, 470; Observations of Jupiter during the present Opposition, P. Vincart, 471; the Moving Object near Jupiter, Prof. Albrecht, 497; Prof. Aitken, 497; the Recently Discovered Satellite of Jupiter, Mr. Melotte, 267; Mutual Occultations and Eclipses of Jupiter's Satellites, Mr. Whitmell, 567; Investigation of Inequalities in the Motion of the Moon produced by the Action of the Planets, Prof. S. Newcomb and Frank E. Ross, 43; Mars as the Abode of Life, Prof. Lowell, 66, 471; Comparisons of the Places of Mars for the Oppositions of 1907 and 1909, Dr. Downing, 67; Photographs of Mars, Prof. Lowell, 182; Is Mars Habitable? a Critical Examination of Prof. Lowell's Book, "Mars and its Canals," with an Alternative Explanation, Dr. Alfred Russel Wallace, F.R.S., Dr. William J. S. Lockyer, 337; the Possibility of Life in Mars, C. O. Bartrum, 392; Dr. J. W. Evans, 392, 413; Dr. W. Ainslie Hollis, 438; Prof. Percival Lowell, 461; Dr. G. Johnstone Stoney, F.R.S., 461; Water Vapour in the Martian Atmosphere, William E. Kolston, 442; Mr. Slipher, 497; Presence of Water Vapour in the Atmosphere of Mars, P. Lowell, 503, 606; Elements and Ephemeris for the Minor Planet Patroclus, V. Heinrich, 67; Evolution of Planets, Edwin G. Camp, W. E. Rolston, 195; a Newly Discovered Bright Minor Planet (1908 B.M.), Dr. Kopff, 281; a Useful Sun and Planet Chart, 302; Occultations of Uranus in 1908, Dr. Downing, 353; Planets now Visible, 353; Recent Observations of Venus, J. M. Harg, 471
- Plankton, das Süsswasser, Dr. Otto Zacharias, 556
- Plant Biology, a Text-book of Elementary Botany arranged for Modern Methods of Teaching, Dr. F. Cavers, 554
- Plant Physiology: Immunity to Disease among Plants, Prof. F. E. Weiss, at British Pharmaceutical Conference at Manchester, 20; Lectures on Plant Physiology, Prof. Ludwig Jost, 97; der Einfluss des Klimas auf den Bau der Pflanzengewebe, Anatomisch-physiologische Untersuchungen in den Tropen, Dr. Carl Holtermann, 313
- Plants: Nature and Development of Plants, C. C. Curtis, 436; Studies in Plant Life, J. Adams, 554
- Plasmogénie, Notions générales de Biologie et de comparées, Prof. A. L. Herrera, 558
- Platypus, the Egg of the, the Reviewer, 80
- Platypus-nest, Eggs of, Prof. Gregg Wilson, 149
- Plimmer (H. G.), Experimental Treatment of Trypanosomiasis in Rats, 238
- Pluvinel (Comte de la Baume), the Recent Transit of Mercury, 116
- Polack (M.), Visibility of Night Signals at Sea, 95
- Polak (S.), the Theory and Practice of Perspective Drawing, 411
- Polarity of Matter, the, Alex. Clark, 210
- Polkingborne (B. C.), Excavation of a Barrow at Chapel Carn Breca, Cornwall, 143; Holed Stone at Kerrow, Cornwall, 143; Cist and Urn at Tregilian Veau, 143
- Pollard (A. F. Campbell), an Experimental Study of Stresses in Masonry Dams, 209
- Pollock (Prof. J. A.), Steady Deflection Method of Current Measurement with an Electrometer, 24
- Pollution of Rivers, the, 36
- Poole (R. H.), Preparation of Conductivity Water, 431
- Pope (F. G.), Colour and Constitution of Azomethine Compounds, 383
- Pope (W. J.), Diethylauric Bromide, 94
- Poppewell (W. C.), Strength of Materials, 412
- Porsch (Dr. O.), Theory with regard to the Embryo Sac, 300
- Porter (Prof. Alfred W.), the Solidification of Helium, 437
- Porter (Mary Winears), What Rome was Built With, a Description of the Stones employed in Ancient Times for its Building and Decoration, 190
- Porthouse (Mr.), Observatory Map of the Moon, 544
- Posidonius on the Originator of the Theory of Atoms, Dr. T. J. J. See, 345
- Post (J.), *Traité complet d'Analyse chimique appliquée aux Essais industriels*, 531
- Potamology: the Winding of Rivers in Plains, Sir Oliver Lodge, F.R.S., 7, 79; R. D. Oldham, 55; R. C. Slater, 79; J. Y. Buchanan, F.R.S., 100; J. Lomas, 102; Dr. John Aitken, F.R.S., 127; the Shaping of Lindsey by the Trent, F. M. Burton, 371
- Potter (Prof. M. C.), the Barley Disease "Deaf Ears," 256
- Poulsen (Valdemar), Telephoning without Wires, 587
- Poultry, Influence of Heredity on the Diseases of, H. B. Greene, 15
- Pewer (F. B.), the Constituents of Essential Oil of Nutmeg, 166
- Poynting (Prof. J. H., F.R.S.), Musical Sands, 248
- Pezzi-Escot (Emm.), the Detection and Estimation of Nickel, 216
- Prain (Lieut.-Col. D., C.I.E., F.R.S.), the Cotton Plant, 318, 485
- Prall (Fr.), the Preservation of Eggs, 84, 137
- Pratt (L.), Reduction of Metallic Oxides with Calcium Hydride and Calcium, 47; Action of Metallic Calcium on Alcohols, 239
- Preservation of Eggs, the, Fr. Prall, 84, 137
- Prest (J. J.), the Shaft Sinking at the Horden Colliery, South-east Durham, 420
- Price (T. Slater), a Course of Practical Organic Chemistry, 74
- Prideaux (W. R. B.), an Annotated Copy of Newton's "Principia," 534
- Prillieux (M.), Disease of the Pine in the Jura, 23
- Pring (T. V.), Meteorological Observations at the British Kite Stations, Session 1906-7, 188
- Prior (Dr.), National Antarctic Expedition, 1901-4, Petrography, 561
- Prior (Dr. G. T.), Strüverite and its Relation to Ilmenorutile, 358
- Prizes proposed by the Paris Academy of Sciences for 1909, 183
- Prolongation of Life, the, Élie Metchnikoff, 289
- Prominence, a Large Eruptive, Mr. Fox, 90
- Prominence, the Large Solar, of May 21, 1907, Father Fényi, 446
- Prominence and Coronal Structure, Dr. William J. S. Lockyer at Royal Society, 514
- Protozoa: die Tierwelt des Mikroskops (die Urtiere), Dr. Richard Goldschmidt, 556
- Przibram (Dr. Hans), Experimental-Zoologie, 529
- Psychology: Elements of Psychology, Dr. S. H. Mellone and Margaret Drummond, 267; an Introduction to Child-study, W. B. Drummond, 410; the Child's Mind, its Growth and Training, W. E. Urwick, 410; the Modern Analysis of Psychical Phenomena, Prof. A. Hoche, 469; the Dancing Mouse, a Study in Animal Behaviour, Robert M. Yerkes, 533; die Mechanik des Geisteslebens, Prof. Max Werworn, 556; New Explanation of Hallucinations, Dr. Boris Sidis, 580
- Pulque, the Manufacture of, 467
- Puringruppe, Untersuchungen in der, (1882-1906), Emil Fischer, 579
- Purpurbakterien, die, Prof. Hans Molisch, Prof. R. T. Hewlett, 53
- Purvis (J. E.), Absorption Spectra of Collidine and 9-Chlorocollidine, 100; Decomposition and Nitrification of Sewage (1) in Alkaline Solution, (2) in Distilled Water, 100-1; Influence of Light and of Copper on Fermentation, 101
- Puzzles, the Canterbury, and other Curious Problems, H. E. Dudeney, 341

- Quaintance (A. L.), Trumpet Leaf-miner of the Apple, *Fischeria malifoliella*, 156
- Queensland, Report on Plague in, (February, 1900-June 30, 1907), B. Burnett Ham, 583
- Quénisset (M.), Photographs of Jupiter, 90
- Racing Animals, the Speed of, Prof. John Perry, F.R.S., 389
- Radial Velocity of β Ursæ Majoris, Variation in the, Dr. H. Ludendorff, 520
- Radiography: the Coloration of Crystallised Alumina, F. Bordas, 17; Use of the Radiometer in observing Small Gas Pressures, Sir James Dewar, F.R.S., 22; the Origin of Radium, Dr. Otto Hahn, 30; Action of Radium Bromide on Precious Stone of the Alumina Family, F. Bordas, 95; the Fatigue of Secondary Radiation due to Radium Rays, J. A. Crowther, 167; the Condensation of Water Vapour in the Presence of the Radium Emanation, Mme. Curie, 167; Dr. H. W. Schmidt's Experiments on the Effect of High Temperatures on the Disintegration of Radium C, 420 (see also Radium); Induction Coil for Röntgen-ray Work, Dr. J. Rosenthal, 65; Action of Röntgen Rays upon Crystallised Alumina, F. Bordas, 95; the Nature of γ and X-rays, Prof. W. H. Bragg, 270, 560; Charlton D. Cooksey, 509; the Nature of Röntgen Rays, Dr. Charles G. Barkla, 319; the Wave-length of Röntgen Rays, Prof. J. Stark, 320; Classification of Secondary X-Radiators, Dr. C. G. Barkla and C. A. Sadler, 343; Dr. B. Walter, 462; the Anode Rays, Drs. F. Gehrcke and O. Reichenheim, 89; Possibility of establishing the Diagnosis of Death by Radiography, Charles Vaillant, 96; the Lithium contained in Radio-active Minerals, Mlle. Gleditsch, 167, 407; Sir W. Ramsay, K.C.B., F.R.S., 412; Lithium in Active Minerals, Sir William Ramsay and Alex. Cameron, 455; Problems of Radio-activity, Dr. G. A. Blanc, 280; Radioactivity in Pearl Fishing, John J. Solomon, 331; the Scattering of the β Rays from Uranium by Matter, J. A. Crowther, 358; the Penetrating Radiation, W. W. Strong, 343; Prof. A. S. Eve, 486; Theory of the Radiation of the Auer Incandescent Gas Mantle, M. Foix, 420; Recent Advances in Radio-activity, Prof. E. Rutherford, F.R.S., at the Royal Institution, 422; the α Particles from Radio-active Substances, Dr. R. S. Willows, 439; Relative Merits of the Radiometer, and the Bolometer for the Measurement of Radiation, W. W. Coblenz, 445; the Nature of γ Rays, Prof. J. J. Thomson, 454; Velocity of Kathodic Secondary Radiation, Prof. J. J. Thomson, 454; Spectrum of the Discharge from a Glowing Lime Kathode in Mercury Vapour, F. Horton, 454; a New Type of Rays, Magnetic Rays, Prof. Augusto Righi, 470; a Standard Unit of Radio-activity, 543; Method of Counting the Number of α Particles from Radio-active Matter, Prof. E. Rutherford and Dr. H. Geiger, 599; the Radio-activity of Ordinary Metals, the Penetrating Radiation from the Earth, Prof. J. C. McLennan, 607; Atmospheric Radio-activity at New Haven, H. M. Dadourian, 615
- Radiotelephony: Telephoning without Wires, Valdemar Poulsen, 587
- Radium: the Origin of Radium, Dr. Otto Hahn, 30; Redetermination of the Atomic Weight of Radium, Madame Curie, 65; the Occurrence of Copper and Lithium in Radium-bearing Minerals, Prof. Herbert N. McCoy, 79; Production and Origin of Radium, Prof. E. Rutherford, 101; Radium and the Earth's Heat, Prof. Harold A. Wilson, F.R.S., 365; Hon. R. J. Strutt, F.R.S., 365; Radium Content of Deep-sea Sediments, Prof. J. Joly, 455; Coloration of Glass and Quartz by Radium, Charles E. S. Phillips, 525
- Ræhlmann (Prof. E.), zur vergleichenden Physiologie des Gesichtsinnes, 103
- Ragno (Prof. E.), la Tecnologia delle Saldature autogene dei Metalli, 508
- Rain Water, Filtration of, Enquirer, 272
- Rainbow (W. J.), a Guide to the Study of Australian Butterflies, 411
- Rainfall and Water Supply, Dr. H. R. Mill at Royal Meteorological Society, 286
- Ramaley (F.), the Silva of Colorado, 399
- Rambaut (Dr. A. A.), a Large Solar Prominence, 66
- Ramsay (A. A.), the Solution of Formaldehyde in Solutions of Cane Sugar, 263
- Ramsay (Sir W., K.C.B., F.R.S.), Lithium in Radio-active Minerals, 412; Lithium in Active Minerals, 455; Commemorative Dinner to, 500
- Raper (H. S.), Condensation of Acetaldehyde and its Relation to the Biochemical Synthesis of Fatty Acids, 47
- Ravold (Dr.), Experiments on Typhoid Fever Bacillus, 69
- Rawitz (Dr. Bernhard), Lehrbuch der mikroskopischen Technik, 605
- Rawson (H. E.), Anticyclonic Belt of the Southern Hemisphere, 599
- Rawson (Robert), Biographical Sketch of, Rev. Robert Harley, F.R.S., 157
- Rayleigh (Lord), Publication of Scientific Works in Embossed Type for the Blind, 204
- Readymony (Nasarvanji Jivanji), Science of Nature-history, 172
- Reed (F. R. Cowper), Lower Palæozoic Fossils of the Northern Shan States, Burma, 116
- Reflection of Polarised Light, C. T. Whitmell, 103
- Refrigerator, the Audiffren, MM. Audiffren and Singrun, 215
- Regeneration and Transplantation, Prof. E. Korschelt, 99
- Reichenheim (Dr. O.), the Anode Rays, 89
- Reid (Clement, F.R.S.), the Geology of the Land's End District, 90; Origin of the Pillow-lava near Port Isaac in Cornwall, 358
- Reid (Dr. G. Archdall), the Interpretation of Mendelian Phenomena, 9, 54; the Inheritance of "Acquired" Characters, 293, 342, 393; Mendelism and Sex, Lecture at Linnean Society, 239
- Reinforced Concrete Construction, Principles of, F. E. Turneure and E. R. Maurer, Supp. to March 5, vi
- Reisser's Fibre in the Frog, George E. Nicholls, 344
- Remington (John Stewart), the Education of To-morrow, 292
- Renouf (Miss N.), Nitro-derivatives of *o*-Xylene, 502; Substituted Dihydrobenzenes, Part II., 1:1-Dimethyl- $\Delta^{2,4}$ -dihydrobenzene and 1:1-Dimethyl- $\Delta^{2,3}$ -dihydrobenzene, 502
- Reinshaw (Graham), Final Natural History Essays, 393
- Repsold (Joh. A.), zur Geschichte der astronomischen Messwerkzeuge von Purbach bis Reichenbach, 1450 bis 1830, 409
- Research, Examination *v.*, Dr. F. C. S. Schiller, 322
- Réseaux, Determination of the Errors of the Paris Observatory, Jules Baillaud, 617
- Retterer (Ed.), Structure of the Fundamental Substance of Hyaline Cartilage, 263
- Revere (G.), I laterizi, 508

REVIEWS AND OUR BOOKSHELF.

- A Description of the Soil-geology of Ireland, based upon Geological Survey Maps and Records, with Notes on Climate, J. R. Kilroe, 4
- Dyeing in Germany and America, Sidney H. Higgins, Prof. Walter M. Gardner, 4
- The Care of the Body, Dr. Francis Cavanagh, 5
- Practical Mathematics, Prof. John Perry, F.R.S., 6
- La Théorie de la Physique chez les Physiciens contemporains, Abel Rey, 6
- How to tell the Birds from the Flowers, a Manual of Floriculture for Beginners, Prof. R. W. Wood, 7
- Zoology of Egypt, the Fishes of the Nile, G. A. Boulenger, F.R.S., 10
- Handbuch der anorganischen Chemie, 25
- Avifauna Italica, Enrico Hillyer Giglioli, 25
- The Physiology of Alimentation, Prof. Martin H. Fischer, 26
- Arithmetic for Schools, Rev. J. B. Lock, 27
- Arithmetic, chiefly Examples, G. W. Palmer, 27
- A Modern Arithmetic, with Graphic and Practical Exercises, H. Sydney Jones, 27
- Die typischen Geometrien und das Unendliche, B. Petronievich, 28
- Engineering Workshop Practice, Charles C. Allen, 28
- Steam and other Engines, J. Duncan, 29

- The Elements of Mechanics, W. S. Franklin and B. Macrunt, 29
- Die Lösung des Problems der Urzeugung (Archigonia, Generatio spontanea), Martin Kuckuck, 29
- The Flora of Columbia, Missouri, and Vicinity, F. P. Daniels, 29
- The Evolution of Matter, Life, and Mind, W. Stewart Duncan, 30
- Ballistic Experiments from 1864 to 1880, Rev. Francis Bashforth, 30
- National Antarctic Expedition, 1901-4, 33
- Investigation of Inequalities in the Motion of the Moon produced by the Action of the Planets, Simon Newcomb and Frank E. Ross, 43
- The Chemistry of Commerce, Robert Kennedy Duncan, 49
- Éléments de Philosophie biologique, Félix le Dantec, 51
- Die Fauna Südwest-Australiens, Ergebnisse der Hamburger südwest-australischen Forschungsreise, Prof. W. Michaelsen and Dr. R. Hartmeyer, 51
- Experimental and Theoretical Applications of Thermodynamics to Chemistry, Dr. Walther Nernst, 52
- Technische Anwendungen der physikalischen Chemie, Dr. Kurt Arndt, 52
- Die Ausgleichsrechnung nach der Methode der kleinsten Quadrate, F. R. Helmert, 52
- Die Purpurbakterien, Prof. Hans Molisch, Prof. R. T. Hewlett, 53
- The Case of Existence, Norman Alliston, 53
- Science German Course, C. W. P. Moffatt, 53
- Les Formations sédimentaires du Crétacé Supérieur et du Tertiaire de Patagonie, avec un Parallèle entre leurs Faunes mammalogiques et celles de l'Ancien Continent, Fiorentino Ameghino, 68
- The Geology and Water Resources of the Western Portion of the Panhandle of Texas, C. Gould, 68
- The Water Supply of Nome Region, Seward Peninsula, J. C. Holt and F. Henshaw, 68
- Underground Waters of the Coastal Plain of Texas, T. U. Taylor, 68
- Potomac River Basin, Parker, Willis, Bolster, and Marsh, 68
- The Quality of Surface Waters in Minnesota, Wesrabot, 68
- Weir Experiments, Coefficients and Formulas, R. E. Horton, 68
- The Nervous System of Vertebrates, Prof. J. B. Johnston, Dr. W. Page May, 73
- Electric Power and Traction, F. H. Davies, 74
- The Complete School Chemistry, F. M. Oldham, 74
- Practical Chemistry for Army and Matriculation Candidates, Geoffrey Martin, 74
- Systematic Practical Organic Chemistry, G. M. Norman, 74
- A Course of Practical Organic Chemistry, T. Slater Price and D. F. Twiss, 74
- A Scheme for the Detection of the more Common Classes of Carbon Compounds, F. E. Weston, 74
- Vergleichende Morphologie der Pflanzen, Dr. Jos. Velenovsky, 76
- De Vormen der Aardkorst, Inleiding tot de Studie der Physiographie, J. van Baren, 76
- Nests and Eggs of Birds found Breeding in Australia and Tasmania, A. J. North, 76
- Grundzüge der Tierkunde für höhere Lehranstalten, Prof. Karl Smallen, 76
- Précis des Caractères générale des Insectes, disposés dans un Ordre naturel par le Citoyen Latreille, 77
- The Metric and British Systems of Weights, Measures, and Coinage, Dr. F. Mollwo Perkin, 77
- The Story of Seraggles (a Sparrow), George W. James, 77
- The Geology of the Land's End District, Clement Reid, F.R.S., and Dr. J. S. Flett, 90
- The Geology of the Country around Hungerford and Newbury, H. J. Osborne White, 90
- The Birds of North and Middle America, R. Ridgway, 91
- Catalogue of the Type and Figured Specimens of Fossils, Minerals, Rocks, and Ores in the Department of Geology, U.S. Mus., J. P. Merrill, 91
- The Families and Genera of Bats, G. S. Miller, 91
- Herpetology of Japan and Adjacent Territory, L. Stejneger, 91
- Report on the Diatoms of the Albatross Voyages in the Pacific Ocean, 1888-1904, Albert Mann, 91
- Lectures on Plant Physiology, Prof. Ludwig Jost, 97
- Liquid and Gaseous Fuels, and the Part they Play in Modern Power Production, Prof. V. B. Lewes, 98
- Rubber Cultivation in the British Empire, Herbert Wright, 99
- School Hygiene, Herbert Jones, 99
- Regeneration and Transplantation, Prof. E. Korschelt, 99
- Organische Zweckmässigkeit, Entwicklung und Vererbung von Standpunkte der Physiologie, Dr. Paul Jensen, 100
- The Cretaceous Flora of Southern New York and New England, Arthur Hollick, 121
- Chapters on Paper-making, Clayton Beadle, 121
- Bird-life of the Borders, on Moorland and Sea, with Faunal Notes extending over Forty Years, Abel Chapman, 122
- The Birds of Kent, William J. Davis, 122
- Notes on the Birds of Rutland, C. Reginald Haines, 122
- A Text-book of Electrical Engineering, Dr. Adolf Thomälen, 124
- The Elements of Electrical Engineering, Profs. W. S. Franklin and Wm. Esty, 124
- Modern Lithology, illustrated and defined, for the Use of University, Technical and Civil Service Students, E. H. Adye, 125
- Inflammation, an Introduction to the Study of Pathology, Prof. J. George Adams, Prof. R. T. Hewlett, 126
- Notes on Maritime Meteorology, Commander M. W. Campbell Hepworth, C.B., 126
- Sunshine and Sport in Florida and the West Indies, F. G. Allalo, 128
- The Annual of the British School at Athens, H. R. Hall, 129
- Mathematische und mikroskopisch-anatomische Studien über Blattstellungen, Dr. G. van Iterson, jun., 145
- Text-book of Organic Chemistry for Medical Students, Dr. G. v. Bunge, 146
- Some Nature Biographies: Plant, Insect, Marine, Mineral, J. J. Ward, 147
- The Fairland of Living Things, R. Kearton, 147
- Physiologisches Praktikum für Mediziner, Prof. Max Verwor, 148
- River Discharge, J. C. Hoyt and N. C. Grover, 148
- Constructions in Practical Geometry, Rev. H. F. Westlake, 148
- Electric Traction, Prof. Ernest Wilson and Francis Lydall, Gisbert Kapp, 169
- The Surgical Anatomy of the Horse, John T. Share-Jones, 170
- The Romance of Savage Life, describing the Life of Primitive Man, his Customs, Occupations, Language, Beliefs, Arts, Crafts, Adventures, Games, Sports, &c., G. F. Scott Elliot, 171
- Die Vegetation der Erde, die Pflanzenwelt von West Australien südlich des Wendekreises, Dr. L. Diels, 171
- Das inneralpine Becken der Umgebung von Wien, Dr. Franz X. Schaffer, 172
- The British Journal Photographic Almanac and Photographer's Daily Companion for 1908, 172
- Science of Nature-history, Nasarvanji Jivanji Readymoney, 172
- Nietzsche in Outline and Aphorism, A. R. Orage, 173
- The Life of the Salmon, W. L. Calderwood, 173
- The Story of Insect Life, W. P. Westell, Fred. V. Theobald, 175
- University of Pennsylvania: Transactions of the Department of Archaeology, Free Museum of Science and Art, H. R. Hall, 186
- Revision of the Pelycosauria of North America, E. C. Case, 186
- Sur la Transmissibilité de Caractères acquis, Eugenio Rignano, 193
- Zur vergleichenden Physiologie des Gesichtsinnes, Prof. E. Rächlmann, 193
- The Flora of West Lancashire, J. A. Wheldon and A. A. Wilson, 194
- The Moon in Modern Astronomy, Ph. Fauth, W. E. Rolston, 195
- Astronomical Essays, Historical and Descriptive, J. Ellard Gore, W. E. Rolston, 195
- Evolution of Planets, Edwin G. Camp, W. E. Rolston, 195
- The Climber's Pocket Book, Rock-climbing Accidents, with Hints on First Aid to the Injured, Some Uses of the

- Rope, Methods of Rescue and Transport, Lionel F. West, 196
- What Rome was built with, a Description of the Stones employed in Ancient Times for its Building and Decoration, Mary Winears Porter, 196
- Nature's Hygiene and Sanitary Chemistry, C. T. Kingzett, 196
- Étude sur les Foudroiements d'arbres constatés en Belgique pendant les Années 1884-1906, E. Vanderlinden, 197
- The Laws of Health, a Handbook on School Hygiene, Dr. Carstairs G. Douglas, 197
- Records of the Geological Survey of India, Notes on Certain Glaciers in North-west Kashmir, H. H. Hayden; Glaciers in Lahaul, H. Walker and E. H. Pascoe; Glaciers in Kumaon, G. de P. Cotter and J. Caggin Brown, Prof. T. G. Bonney, F.R.S., 201
- An Experimental Study of the Stresses in Masonry Dams, Karl Pearson, F.R.S., and A. F. Campbell Pollard, Prof. E. Brown, 209
- The Electrical Conductivity of Aqueous Solutions, Arthur A. Noyes, 213
- Conductivity and Viscosity in Mixed Solvents, Harry C. Jones, 213
- Histoire de la Navigation aérienne, W. de Fonvielle, 217
- The Garden Beautiful: Home-woods and Home Landscape, William Robinson, 217
- Clean Water, and How to Get It, Allen Hagen, 218
- A Manual of Veterinary Physiology, Colonel F. Smith, C.B., C.M.G., Dr. Percy T. Herring, 219
- The Polarity of Matter, Alex. Clark, 219
- Wild Bees, Wasps and Ants, and other Stinging Insects, Edward Saunders, F.R.S., 220
- Das Problem der Schwingungszeugung, Dr. H. Barkhausen, 220
- Album de Aves Amazonicas, Dr. E. A. Goeldi, 220
- Newfoundland and its Untrodden Ways, J. G. Millais, 223
- Plagues and Pleasures of Life in Bengal, Lieut.-Colonel D. D. Cunningham, 223
- The Sutherland Volcanic Pipes and their Relationship to other Vents in South Africa, A. W. Rogers and A. L. du Toit, Dr. F. H. Hatch, 224
- The Diamond Pipes and Fissures of South Africa, H. S. Harger, Dr. F. H. Hatch, 224
- The Occurrence in Kimberlite of Garnet-pyroxene Nodules carrying Diamonds, G. S. Corstorphine, Dr. F. H. Hatch, 224
- Kimberlite Dykes and Pipes, F. W. Voit, Dr. F. H. Hatch, 224
- The Origin of Diamonds, F. W. Voit, Dr. F. H. Hatch, 224
- Geological Survey of the Eastern Portion of Griqualand West, A. L. du Toit, Dr. F. H. Hatch, 224
- Ueber die südafrikanischen Diamantlagerstätten, A. Macco, Dr. F. H. Hatch, 224
- Untersuchungen über einige südafrikanische Diamantlagerstätten, R. Beck, Dr. F. H. Hatch, 224
- The Wild and Cultivated Cotton Plants of the World, a Revision of the Genus *Gossypium*, Sir G. Watt, F. Fletcher, 241
- Evolution and Animal Life, an Elementary Discussion of Facts, Processes, Laws, and Theories relating to the Life and Evolution of Animals, David Starr Jordan and Vernon Lyman Kellogg, 242
- The Practice of Instruction, 243
- Road-making and Maintenance, a Practical Treatise for Engineers, Surveyors, and Others, Thomas Aitken, 244
- A History of Chemistry, Hugo Bauer, 244
- Neolithic Dew-ponds and Cattle-ways, Dr. Arthur John Hubbard and George Hubbard, W. E. Rolston, 245
- Übungsbeispiele aus der anorganischen Experimentalchemie, Heinrich Blitz und Wilhelm Blitz, 245
- The Bacteriological Examination of Disinfectants, William Partridge, Prof. R. T. Hewlett, 246
- Ergebnisse und Fortschritte der Zoologie, 246
- Observations simultanées de la Surface de Jupiter réunies, M. Jean Mascart, 250
- Manx Crosses: or the Inscribed and Sculptured Monuments of the Isle of Man from about the end of the Fifth to the Beginning of the Thirteenth Century, P. M. C. Kermode, 265
- Van Nostrand's Chemical Annual, 1907, 267
- Elements of Psychology, Dr. S. H. Mellone and Margaret Drummond, 267
- Die Physik Roger Bacos, Sebastian Vogl, 268
- The Preservation of Infant Life, Emilia Kanthack, 268
- Sanitation in Daily Life, Ellen H. Richards, 268
- Der neue Leitfaden, L. M. de la Motte Tischbrock, 268
- Memoirs of the Geological Survey of Great Britain, the Geological Structure of the North-west Highlands of Scotland, B. N. Peach, John Horne, W. Gunn, C. T. Clough, and L. Hinxman; Petrological Notes, J. J. H. Teall, Prof. J. W. Gregory, F.R.S., 272
- On the Impulses of Compound Sound Waves and their Mechanical Transmission through the Ear, Sir Thomas Wrightson, Bart., 289
- The Prolongation of Life, Élie Metchnikoff, 289
- Proceedings of the Aristotelian Society, 290
- Ancient Egypt the Light of the World: a Work of Reclamation and Restitution, Gerald Massey, 291
- Primitive Traditional History: the Primitive History and Chronology of India, South-eastern and South-western Asia, Egypt, and Europe, and the Colonies thence sent forth, J. F. Hewitt, 291
- Cyclopedia of American Agriculture, 292
- Penrose's Pictorial Annual, 1907-8, 292
- The Education of To-morrow, John Stewart Remington, 292
- Scouting for Boys, Lieut.-Colonel R. S. S. Baden-Powell, C.B., 293
- Photograms of the Year 1907, 293
- India-rubber and its Manufacture; with Chapters on Gutta-percha and Balata, Hubert L. Terry, C. Simmonds, 296
- Report on Scenery Preservation for the Year 1906-7, Prof. Arthur Dendy, 297
- Report on a Botanical Survey of Kapiti Island, L. Cockayne, Prof. Arthur Dendy, 297
- Der Einfluss des Klimas auf den Bau der Pflanzengewebe, Anatomisch-physiologische Untersuchungen in den Tropen, Dr. Carl Holtermann, 313
- The Pulse of Asia: a Journey in Central Asia illustrating the Geographic Basis of History, Ellsworth Huntington, Prof. Grenville A. J. Cole, 314
- Microscopy the Construction, Theory, and Use of the Microscope, E. J. Spitta, 314
- Easy Exercises in Algebra for Beginners, W. S. Beard, 315
- Plane Geometry for Secondary Schools, C. Davison and C. H. Richards, 315
- Cartesian Plane Geometry, Charlotte A. Scott, 315
- A Sequel to Elementary Geometry, J. W. Russell, 315
- Text-book of Mechanics, L. A. Martin, jun., 315
- Elementary Statics, W. P. Borchardt, 315
- Elementary Trigonometry, C. Hawkins, 315
- Mining Tables, Dr. F. H. Hatch and E. J. Valentine, 317
- The Weights and Measures of International Commerce, 317
- Les Aciers spéciaux, L. Revillon, 317
- Voice Training in Speech and Song, H. H. Hulbert, 317
- Revisio Conocephalidarum, H. Karny, 317
- Seed and Soil Inoculation for Leguminous Crops, Prof. W. B. Bottomley, 330
- Is Mars Habitable? a Critical Examination of Prof. Lowell's Book, "Mars and its Canals," with an Alternative Explanation, Dr. Alfred Russel Wallace, F.R.S., Dr. William J. S. Lockyer, 337
- (1) Races bovine, France—Étranger, (2) Races chevalines, Prof. Paul Diftloh, 339
- Medico-Physical Works of John Mayow (1674), 339
- Town Gas and its Uses for the Production of Light, Heat, and Motive Power, W. H. Y. Webber, 340
- The Canterbury Puzzles and other Curious Problems, H. E. Dudeney, 341
- Matter and Intellect: a Reconciliation of Science and the Bible, Andrew Allan, 341
- Leçons sur la Viscosité des Liquides et des Gaz, Marcel Brillouin, 341
- Aphorisms and Reflections, T. H. Huxley, 341
- The Journal of the South-eastern Agricultural College, Wye, Kent, 345
- Transvaal Mines Department, Report of the Geological Survey for the Year 1906, Dr. F. H. Hatch, 346
- Notes on Indian Mathematics, Arithmetical Notation, R. Kaye, 347
- Memoirs of the Indian Meteorological Department, being

- Occasional Discussions and Compilations of Meteorological Data relating to India and the Neighbouring Countries, V., a Discussion of the Anemographic Observations recorded at Allahabad from September, 1890, to August, 1904; VI., a Discussion of the Anemographic Observations recorded at Lucknow from June, 1878, to October, 1892, Sir John Elliot, K.C.I.E., F.R.S., 353
- Report of the Education Committee of the London County Council submitting the Report of the Medical Officer (Education) for the Year ended March 31, 1907, 355
- Continuation Schools in England and Elsewhere, Prof. J. Wertheimer, 361
- Island in Vergangenheit und Gegenwart, Paul Herrman, 362
- Organic Chemistry for Advanced Students, Prof. J. B. Cohen, 363
- The Geology of the Leicestershire and South Derbyshire Coalfield, C. Fox-Strangways, 364
- Inorganic Chemistry, E. J. Lewis, 364
- Altitude Tables, F. Ball, 365
- Problems in Strength of Materials, Dr. William Kent Shephard, 365
- Whittaker's Arithmetic of Electrical Engineering for Technical Students and Engineers, 365
- An Essay upon Disease: its Cause and Prevention, Dr. G. E. Richmond, 365
- The Shaping of Lindsey by the Trent, F. M. Burton, 371
- Aus Namaland und Kalahari, Prof. Leonhard Schultze, Sir H. H. Johnston, G.C.M.G., 385
- Alcohol and the Human Body, Sir Victor Horsley, F.R.S., and Dr. Mary D. Sturge, 386
- Die Zustandsgleichung der Gase und Flüssigkeiten und die Continuitätstheorie, Prof. J. P. Kuennen, 387
- Forage Crops for Soiling, Silage, Hay and Pasture, Dr. Edward B. Voorhees, 388
- Astronomischer Jahresbericht, A. Berberich, 389
- Lehrbuch der theoretischen Elektrochemie auf thermodynamischer Grundlage, J. J. van Laar, 389
- Coal, James Tonge, 389
- Whose Home is in the Wilderness: some Studies of Wild Animal Life, W. J. Long, 393
- Final Natural History Essays, Graham Renshaw, 393
- Home-life of some Marsh-birds, Emma L. Turner and P. H. Bahr, 393
- Drapers' Company Research Memoirs, ii., a First Study of the Statistics of Pulmonary Tuberculosis, Prof. Karl Pearson, F.R.S., 394
- Zur Geschichte der Astronomischen Messwerkzeuge von Purbach bis Reichenbach 1450 bis 1830, Joh. A. Repsold, 409
- An Introduction to Child-study, W. B. Drummond, 410
- The Child's Mind: its Growth and Training, W. E. Urwick, 410
- The Essentials of Cytology, Charles Edward Walker, 410
- Immune Sera, Dr. C. F. Bolduan, 411
- A Guide to the Study of Australian Butterflies, W. J. Rainbow, 411
- The Theory and Practice of Perspective Drawing, S. Polak, 411
- Strength of Materials, W. C. Poppell, 412
- Researches on the Performance of the Screw Propeller, Prof. W. F. Durand, 416
- Memorandum on Medical Inspection of Children in Public Elementary Schools, 426
- Memorandum by British Medical Association on the Circular of the Board of Education, 426
- Schedule of Medical Inspection, 426
- A Description of the First or Aswan Cataract of the Nile, Dr. John Ball, 433
- Das Lachgas: eine Chemisch-kultur-historische Studie, Prof. Ernst Cohen, 434
- Evolution of Mammalian Molar Teeth, to and from the Triangular Type, H. F. Osborn, 435
- Nature and Development of Plants, C. C. Curtis, 436
- The Diseases of Animals, Nelson S. Mayo, 436
- Traité de Chimie analytique qualitative, suivi de Tables systématiques pour l'Analyse Minérale, Louis Duparc and Alfred Monnier, 437
- Actualités Scientifiques, Max de Nansouty, 437
- California and the Californians: the Alps of King-Kern Divide, President D. S. Jordan, 437
- Burial Customs of Ancient Egypt, Prof. J. Garstang, H. R. Hall, 439
- Proceedings of the First International Conference on the Sleeping Sickness held at London in June, 1907, 440
- Practical Coal Mining, 457
- Malaria, a Neglected Factor in the History of Greece and Rome, W. H. S. Jones, 457
- Cours d'Électricité, H. Pellat, 458
- Les Découvertes Modernes en Physique, O. Manville, 458
- The Oceanic Languages: their Grammatical Structure, Vocabulary, and Origin, Dr. D. Macdonald, 460
- Searchlights: their Theory, Construction, and Application, F. Nerz, 460
- Beyond Good and Evil, Prelude to a Philosophy of the Future, Friedrich Nietzsche, 460
- Glaciers of the Canadian Rockies and Selkirks, Dr. William Hittell Sherzer, Prof. T. G. Bonney, 463
- Chemische und biologische Untersuchungen von ägyptischen Mumien-material, W. A. Schmidt, Prof. W. D. Halliburton, F.R.S., 465
- Earthquakes: an Introduction to Seismic Geology, William Herbert Hobbs, 481
- Mikroskopisches und physiologisches Praktikum der Botanik für Lehrer, G. Müller, 481
- Handboek der botanische Micrographie, Dr. J. W. Moll, 481
- Grundzüge der Pflanzenkunde, Prof. K. Smalian, 481
- Anatomische Physiologie der Pflanzen und der Menschen, Prof. K. Smalian, 481
- The New Matriculation Heat, 482
- The New Matriculation Light, 482
- The New Matriculation Sound, 482
- A First Year's Course in Geometry and Physics, Ernest Young, 482
- A Second Year's Course in Practical Physics, James Sinclair, 482
- A Third Year's Course in Practical Physics, James Sinclair, 482
- The Mechanism of Speech, Alexander Graham Bell, Prof. John G. McKendrick, F.R.S., 483
- The Moths of the British Isles, Richard South, 483
- Physiologie und Anatomie des Menschen, mit Ausblicken auf den Ganzen Kreis der Wirbeltiere, Dr. Felix Kienitz-Gerloff, 484
- The Elements of Geography, J. H. N. Stephenson, 484
- Lehrbuch der Chemie und Mineralogie für die vierte Klasse der Realschulen, Franz von Hemmelmayr and Dr. Karl Brunner, Heinrich Leitenberger, 484
- Recent Madrepatria of the Hawaiian Islands and Laysan, T. Wayland Vaughan, Prof. S. J. Hickson, F.R.S., 490
- The Corpuscular Theory of Matter, Prof. J. J. Thomson, F.R.S., 505
- Atlas of the World's Commerce, 506
- Symmetrical Masonry Arches, M. A. Howe, 507
- Das Kausalitätsprinzip der Biologie, Dr. Friedrich Strecker, 507
- Pharmakognostisches Praktikum, Dr. Ludwig Koch and Dr. Ernst Gilg, 508
- Die Pendulations-theorie, Dr. Heinrich Simroth, 508
- The Minimising of Maurice, being the Adventures of a very Small Boy among very Small Things, Rev. S. N. Sedgwick, 508
- Les Progrès de la Photographie astronomique, Prof. P. Stroobant, 508
- I laterizi, G. Revere, 508
- La Tecnologia delle Saldature autogene dei Metalli, Prof. S. Ragno, 508
- The Birds of Yorkshire, T. H. Nelson, W. Eagle Clarke, and F. Boyes, 511
- Notes on the Birds of Kent, R. J. Balston, Rev. C. W. Shepherd, and E. Bartlett, 511
- Experimental-Zoologie, Dr. Hans Przibram, 520
- Geologische Prinzipienfragen, E. Reyer, Prof. Grenville A. J. Cole, 520
- Hydraulics, F. C. Lea, 530
- Traité Complet d'Analyse Chimique appliquée aux Essais industriels, J. Post and B. Neumann, 531
- Papers of the British School at Rome, 532
- Armature Construction, H. M. Hobart and A. G. Ellis, 532

The Darning Mouse: a Study in Animal Behaviour, Robert M. Yerkes, 533
 Studies in the Medicine of Ancient India, Dr. A. F. Rudolf Hoernle, 533
 The Sea-shore shown to the Children, Janet Harvey Kelman, Frank Balfour Browne, 533
 Dévations des Compas, Pierre Engel, 534
 Bulletin of Miscellaneous Information, Royal Botanic Gardens, Kew, 534
 The Will to Doubt: an Essay in Philosophy for the General Thinker, Alfred H. Lloyd, 534
 Trees and their Life-histories, Prof. P. Groom, 538
 The Ziegler Polar Expedition, 1903-5, Anthony Fiala, Dr. C. Chree, F.R.S., 544
 Chemie der höheren Pilze, eine Monographie, Dr. Julius Zellner, Prof. R. Meldola, F.R.S., 553
 Plant Biology, a Text-book of Elementary Botany arranged for Modern Methods of Teaching, Dr. F. Cavers, 554
 Laboratory and Field Manual of Botany, J. Y. Bergen and B. M. Davis, 554
 Studies in Plant Life, J. Adams, 554
 Elementary Botany, M. A. Liversidge, 554
 Introduction to Elementary Botany, Charlotte L. Laurie, 554
 Our Woodlands, Heaths, and Hedges, W. S. Coleman, 554
 Computation and Mensuration, P. A. Lambert, 555
 A First Statics, C. S. Jackson and R. M. Milne, 555
 Practical Calculations for Engineers, C. E. Larard and H. A. Golding, 555
 Die Tierwelt des Mikroskops (die Urtiere), Dr. Richard Goldschmidt, 556
 Das Süßwasser-Plankton, Dr. Otto Zacharias, 556
 Befruchtung und Vererbung in Pflanzenreiche, Prof. K. Giesenhagen, 556
 Das Werden und Vergehen der Pflanzen, Prof. P. Gisevius, 556
 Das Schmarotzertum im Tierreich und seine Bedeutung für die Artbildung, Prof. Ludwig von Graff, 556
 Die Mechanik des Geisteslebens, Prof. Max Verworn, 556
 Index of Archaeological Papers (1665-1890), 557
 Notions générales de Biologie et de Plasmogénie comparées, Prof. A. L. Herrera, 558
 Einführung in die Paläontologie, Gustav Steinmann, 558
 The Chemistry of the Diazo-compounds, Dr. J. C. Cain, 558
 Handbuch der Physik, Dr. A. Winkelmann, 559
 National Antarctic Expedition, 1901-1904, Natural History, vol. 1, Geology, H. T. Ferrar and Dr. Prior, Prof. J. W. Gregory, 561
 Airships Past and Present, together with Chapters on the Use of Balloons in connection with Meteorology, Photography, and the Carrier Pigeon, A. Hildebrandt, 562
 The Games of the North American Indians, Stewart Culin, Dr. A. C. Haddon, F.R.S., 568
 A First Course in the Differential and Integral Calculus, Dr. W. F. Osgood, 577
 L'Europe Préhistorique, Sophus Müller, Dr. William Wright, 578
 Untersuchungen in der Puringruppe (1882-1906), Emil Fischer, 579
 Iron and Steel, J. H. Stansbic, 579
 L'Énergétique et le Mécanisme au Point de Vue des Conditions de la Connaissance, Abel Rey, 580
 Abel's Laboratory Handbook of Bacteriology, Prof. R. T. Hewlett, 580
 Die Bestimmung und Vererbung des Geschlechtes, Dr. C. Correns, 580
 Lehrbuch der Physik, Prof. H. A. Lorentz, 580
 Reports on Plague Investigations in India, issued by the Advisory Committee appointed by the Secretary of State for India, the Royal Society, and the Lister Institute, 585
 Report on Plague in Queensland, B. Burnett Ham, 585
 The Etiology and Epidemiology of Plague, 585
 Ancient Britain and the Invasions of Julius Caesar, Dr. T. Rice Holmes, 601
 Synopsis of Linear Associative Algebra, J. B. Shaw, 603
 Lehrbuch der medizinischen Physik, Prof. H. Boruttan, 604

Musée ostéologique, Étude de la Faune quaternaire, Ostéométrie des Mammifères, E. Hue, 604
 The Children's Book of Stars, G. E. Mitton, 605
 Cradle Tales of Hinduism, Margaret E. Noble, 605
 Lehrbuch der mikroskopischen Technik, Dr. Bernhard Rawitz, Prof. R. T. Hewlett, 605
 The Influence of Inanition on Metabolism, Francis Gano Benedict, 610
 Les récents Progrès du Système métrique, Ch.-Ed. Guillaume, 611
 Scottish National Antarctic Expedition, Report on the Scientific Results of the Voyage of the s.s. *Scotia* during the Years 1902, 1903, and 1904, under the leadership of W. S. Bruce, Vol. ii., Physics, 618

SUPPLEMENT TO MARCH 5.

Comparative Electro-physiology, Prof. J. C. Bose, iii
 Die binokularen Instrumente, Moritz von Rohr, iv
 Physiography, Prof. R. D. Salisbury, v
 An Introduction to the Theory of Multiply-Periodic Functions, Dr. H. F. Baker, v
 Principles of Reinforced Concrete Construction, F. E. Turneure and E. R. Maurer, vi
 The Heritage of Dress, being Notes on the History and Evolution of Clothes, W. M. Webb, vii
 Modern Views of Electricity, Sir Oliver Lodge, F.R.S., viii
 Der naturwissenschaftliche Unterricht auf praktisch-heuristischer Grundlage, Dr. F. Dannemann, viii
 Jahrbuch der drahtlosen Telegraphie und Telephonie, ix
 Wireless Telephony in Theory and Practice, E. Ruhmer, ix
 The Tabernacle: its History and Structure, Rev. W. Shaw Caldecott, x
 Solomon's Temple: its History and Structure, Rev. W. Shaw Caldecott, x
 Revillon (L.), les Aciers spéciaux, 317
 Rey (Abel), la Théorie de la Physique chez les Physiciens contemporains, 6; L'Énergétique et le Mécanisme au Point de Vue des Conditions de la Connaissance, 580
 Keyer (E.), Geologische Prinzipienfragen, 529
Rhynchobdella auleata in Ceylon, Dr. Arthur Willey, F.R.S., 345
 Ricco (Prof.), Solar Prominences in 1906, 138; the Astrographic Catalogue, 158; Gravitational Survey of Sicily and Calabria, 232
 Richards (C. H.), Plane Geometry for Secondary Schools, 315
 Richards (Ellen H.), Sanitation in Daily Life, 268
 Richards (T. W.), Manganese Chloride as Fixed Point in Thermometry, 207
 Richardson (L. F.), Freehand Graphic Way of determining Stream Surfaces and Equipotentials, 118; an Experimental Study of Stresses in Masonry Dams, 209; the Lines of Flow of Water in Saturated Soils, especially Peat-mosses, 407
 Richmond (Dr. G. E.), an Essay upon Disease: its Cause and Prevention, 365
 Rideal (R.), Relative Hygienic Values of Gas and Electric Lighting, 613
 Ridgeway (Prof.), Origin of the Crescent as a Mohammedan Badge, 502
 Ridgway (R.), the Birds of North and Middle America, 91
 Righi (Prof. Augusto), Magnetic Rays, a New Type of Rays, 470
 Rignano (Eugenio), sur la Transmissibilité de Caractères acquis, 193
 Ristenpart (Dr.), Saturn's Rings, 67
 River Discharge, J. C. Hoyt and N. C. Grover, 148
 Rivers in Plains, the Winding of, Sir Oliver Lodge, F.R.S., 7, 79; R. D. Oldham, 55; R. C. Slater, 79; J. Y. Buchanan, F.R.S., 100; J. Lomas, 102; Dr. John Aitken, F.R.S., 127
 Rivers, the Pollution of, 36
 Road-making and Maintenance, Thomas Aitken, 244
 Roaf (Dr.), the Equilibrium between the Cell and its Environment in regard to Soluble Constituents, 399
 Robinson (R.), Synthesis of Braziliac Acid, 166; Synthesis of Anhydrobraziliac Acid, 431

- Robinson (William), the Garden Beautiful: Home-woods and Home Landscape, 217
- Rogers (A. W.), the Sutherland Volcanic Pipes and their Relationship to other Vents in South Africa, 224
- Rohr (Moritz von), die binokularen Instrumente, Supp. to March 5, iv
- Rolla (Luigi), Theory of the Mirage, 356
- Rolston (W. E.), the Moon in Modern Astronomy, Ph. Fauth, 195; Astronomical Essays, Historical and Descriptive, J. Elland Gore, 195; Evolution of Planets, Edwin G. Camp, 195; Neolithic Dew-ponds and Cattleways, Dr. Arthur John Hubbard and George Hubbard, 245; Water Vapour in the Martian Atmosphere, 442
- Rome: What Rome was built with, a Description of the Stones employed in Ancient Times for its Building and Decoration, Mary Winearls Porter, 196; Malaria, a Neglected Factor in the History of Greece and Rome, W. H. S. Jones, 457; the Forthcoming Mathematical Congress at, Prof. G. H. Bryan, F.R.S., 464; the International Mathematical Congress at, Prof. G. H. Bryan, F.R.S., 582; Papers of the British School at, 532
- Röntgen-ray Work, Induction Coil for, Dr. J. Rosenthal, 65
- Röntgen Rays, the Nature of, Dr. Charles G. Barkla, 319; the Wave-length of, Prof. J. Stark, 320
- Rosa (E. B.), Maxwell's Bridge Method of determining the Ratio of the Electromagnetic to the Electrostatic Unit of Electricity, 136
- Rose (Dr. T. K.), Alloys of Gold and Tellurium, 406
- Rosenhain (W.), Recalescence Curves, 382
- Rosenthal (Dr. J.), Induction Coil for Röntgen-ray Work, 65
- Rosenthal (Pierre), Prolonged Anaesthesia by Mixture of Oxygen and Ethyl Chloride, 263
- Ross (A. D.), Sensitive State induced in Magnetic Materials by Thermal Treatment, 407
- Ross (Frank E.), Investigation of Inequalities in the Motion of the Moon produced by the Action of the Planets, 43
- Ross (Prof. Ronald), the Prevention of Malaria, 39
- Rosse (Lord), a Contribution to the History of Ironclads, 356
- Rotch (Prof. A. L.), Franklin's Description of the First Balloon Ascents, 256
- Rothsay Summers and Greenwich Winters, Alex. B. MacDowall, 438
- Roux (Jules), Abnormal Mobility of the Ions of some Rare Earths, 335
- Rowell (H. W.), Determinations of Small Quantities of Bismuth, 263
- Roy (Félix de), the Recent Maximum of Mira Cete, 544
- Royal Agricultural Society, Report of, 134
- Royal Anthropological Institute, 94, 139, 143, 166, 359, 406, 454, 502, 551
- Royal Astronomical Society, 94, 478, 575
- Royal Dublin Society, 191, 239, 407, 455
- Royal Institution, the Centenary of Davy's Discovery of the Metals of the Alkalis, Prof. T. E. Thorpe, C.B., F.R.S., 305; Recent Advances in Radio-activity, Prof. E. Rutherford, F.R.S., at, 422; Nerve as a Master of Muscle, Prof. C. S. Sherrington at, 509; Recent Earthquakes, Prof. J. Milne, F.R.S., at, 502
- Royal Irish Academy, 239
- Royal Meteorological Society, 187, 453, 478, 599; Rainfall and Water-supply, Dr. H. R. Mill, 286
- Royal Microscopical Society, 46, 188, 311, 454, 551
- Royal Society, 22, 71, 141, 164, 187, 238, 262, 287, 310, 332, 358, 382, 430, 476, 501, 549, 574, 623; Royal Society Medal Awards for 1907, 38; Anniversary Meeting of the Royal Society, 107; a Method of depositing Copper upon Glass from Aqueous Solutions in a thin brilliantly reflecting Film and thus producing a Copper Mirror, Dr. F. D. Chattaway, F.R.S., at, 380; Prominence and Coronal Structure, Dr. William J. S. Lockyer, 514; Reports on Plague Investigations in India issued by the Advisory Committee appointed by the Secretary of State for India, the Royal Society, and the Lister Institute, 585
- Royal Society, Edinburgh, 311, 335, 497, 431, 479, 551; Lord Kelvin and the Royal Society of Edinburgh, 253
- Royal Society of Sciences, Göttingen, 72, 312, 479
- Rubber: Rubber Cultivation in the British Empire, Hebert Wright, 99; Influence of Formal on *Funtumia elastica*, Dr. P. Schidrowitz and F. Kaye, 189
- Rudenberg (Dr.), Simple Method of generating an Alternating Current of any Desired Frequency, 41
- Ruhmer (E.), Wireless Telephony in Theory and Practice, Supp. to March 5, ix
- Russ (S.), Distribution in Electric Fields of the Active Deposits of Radium, Thorium, and Actinium, 503
- Russell (E. S.), Correlation of Modifications of the Limpet-shell with Environmental Conditions, 186
- Russell (J. W.), a Sequel to Elementary Geometry, 315
- Russian Scientific Publications, 498
- Rutherford (Prof. E., F.R.S.), Production and Origin of Radium, 191; Recent Advances in Radio-activity, Lecture at Royal Institution, 422; Method of counting the Number of a Particles from Radio-active Matter, 599
- Rutland, Notes on the Birds of, C. Reginald Haines, 122
- Ryan (H.), Derivatives of Xylose, 191
- Sabatier (Paul), Direct Hydrogenation of some Aromatic Diones, 107; Direct Hydrogenation of the Aromatic Quinones, 455
- Sabine (Prof. W. C.), Music and Melody, 378
- Sadler (C. A.), Classification of Secondary X-radiators, 343
- Saito (D.), the Refining of Copper, 206
- Saldature autogene dei Metalli, la Tecnologia delle, Prof. S. Ragno, 508
- Salisbury (Prof. R. D.), Physiography, Supp. to March 5, v
- Salmon (E. S.), History of the Gooseberry Mildew Order of July, 1907, 591; the "Black Scab" or "Warty Disease" of Potatoes, 591
- Salmon, the Life of, with Reference more especially to the Fish in Scotland, W. L. Calderwood, 173
- Salway (A. H.), the Constituents of Essential Oil of Nutmeg, 166
- Sanatoria for Consumption, Dr. R. Fielding-Ould, 546
- Sand, Musical, Cecil Carus-Wilson, 222, 271; Prof. J. H. Poynting, F.R.S., 248; Sidney Skinner, 248
- Sand, Singing, from New England, S. Skinner, 188
- Sang (Alfred), Old and New Methods of Galvanising, 179
- Sang's (Dr. Edward) Collection of MS. Calculations in Trigonometry and Astronomy, Dr. R. H. Traquair, F.R.S., 13
- Sanger (C. R.), the Quantitative Determination of Arsenic by the Gutzeit Method, 519
- Sanitation: the Pollution of Rivers, 36; Sanitation in Daily Life, Ellen H. Richards, 268; Utilisation of Turf for the Purification of Sewage, A. Muntz and E. Laine, 287
- Saturn's Rings, Prof. Campbell, 18; Dr. Ristenpart, 67; Prof. Hartwig, 67; Prof. Lowell, 67, 116, 616; Paul Guthnick, 67; Prof. B. Peter, 90; M. Schær, 90; Dr. Hassenstein, 99; Rev. T. E. R. Phillips, 234; Dr. Lau, 234; Prof. Barnard, 401; Mr. Lampland, 616; Saturn apparently without Rings, M. Flammarion, 182; a New Ring suspected, G. Fournier, 302; the Saturn Perturbations of Various Comets, Dr. Johannes Wenzel, 568
- Saunders (Edward, F.R.S.), Wild Bees, Wasps and Ants, and other Stinging Insects, 220
- Savage Life, the Romance of, describing the Life of Primitive Man, his Customs, Occupations, Language, Beliefs, Arts, Crafts, Adventures, Games, Sports, &c., G. F. Scott Elliot, 171
- Savariau (M.), Method of preparing the Cyclic Aldehydes, 384
- Scenery Preservation for the Year 1906-7, Report on, Prof. Arthur Dendy, 297
- Schaeffer (G.), Influence of the Reaction of the Medium on the Size of the Colloidal Granules, 119
- Schær (M.), Saturn's Rings, 90
- Schær (E.), the Objective Prism in Solar Spectroscopy, 401
- Schäfer (Prof. E. A., F.R.S.), on the Incidence of Daylight as a Determining Factor in Bird-migration, 159
- Schaffer (Dr. Franz X.), das inneralpine Becken der Umgebung von Wien, 172
- Schidrowitz (Dr. P.), Influence of Formal on *Funtumia elastica*, 189
- Schiller (Dr. F. C. S.), Examination v. Research, 322
- Schirs (Mr.), Endeavour to apply recent Chemical Theories

- towards elucidating the Origin and Formation of the Diamond from Quartz-bearing Rocks, 542
- Schlesinger (Dr. Frank), the Distortion of Photographic Films in Stellar Work, 328
- Schmarzertum in Tierreich und seine Bedeutung für die Artbildung, das, Prof. Ludwig von Graff, 550
- Schmauss (A.), Unmanned Balloon Ascents in 1907 at Munich, 495
- Schmidt (W. A.), Chemische und biologische Untersuchungen von ägyptischen Mumien-material, nebst Betrachtungen über das Einbalsamierungsverfahren der alter Ägypter, 495
- Schmidt's (Dr. H. W.) Experiments on the Effect of High Temperatures on the Disintegration of Radium C, 420
- Schneider (Prof. J.), Moon's Influence on the Wind Components at Hamburg, 409
- School Hygiene: a Handbook for Teachers of all Grades, School Managers, &c., Herbert Jones, 99; the Laws of Health, a Handbook on, Dr. Carstairs G. Douglas, 107
- Schools, Arithmetic for, Rev. J. B. Lock and V. M. Turnbull, 27
- Schorr (Prof.), the Hamburg Observatory, 544
- Schott (Dr. G. A.), a Fundamental Contradiction between the Electrical Theory of Dispersion and the Phenomena of Spectrum Series, 413
- Schrenk (Dr. H. von), Growth connected with Natural Injuries to Trees, 505
- Schullen (A. de), New Mineral Species, arising from the Athenian Plumbiferous Scoria of Laurium, 95
- Schultze (Prof. Leonhard), aus Namaland und Kalahari, 385
- Schuster (Prof. Arthur, F.R.S.), the Diurnal Variation of Terrestrial Magnetism, 164; Electrical Phenomena of the Atmosphere and their Relations with Solar Activity, 301
- Schwingungserzeugung, das Problem der, Dr. H. Barkhausen, 220
- Science: Science German Course, C. W. P. Moffatt, 53; Science at the Franco-British Exhibition of 1908, 67; the Science Court of the Franco-British Exhibition, 609; Science of Nature-history, Nasarvanji Jivanji Ready-money, 172; Scientific Work of the Local Government Board, Prof. R. T. Hewlett, 235; the British Science Guild, 274; Science at Recent Educational Conferences, G. F. Daniell, 281; Forthcoming Science, 427; Actualités scientifiques, Max de Nansouty, 437; Science and Industry, 621; der naturwissenschaftliche Unterricht auf praktisch-heuristischer Grundlage, Dr. F. Danne-mann, Supp. to March 5, viii
- Scientific Centres, Some, XII., the Botanical Institute of the University of Bonn, Prof. E. Strasburger, Prof. D. M. Mottier, 321
- Scientific Worthies, Sir William Crookes, F.R.S., Prof. P. Zeeman, 1
- Scotland: Scottish Natural History Society, on the Incidence of the Daylight as a determining Factor in Bird-migration, Address by Prof. E. A. Schäfer, F.R.S., 150; the Geological Structure of the North-west Highlands of Scotland, B. N. Peach, John Horne, W. Gunn, C. T. Clough, L. Hinxman, and J. J. H. Teall, Prof. J. W. Gregory, F.R.S., 272; Scottish National Antarctic Expedition Report on the Scientific Results of the S.Y. Scotia during the Years 1902, 1903, and 1904, under the Leadership of W. S. Bruce, Vol. ii., Physics, 618
- Scott (Charlotte A.), Cartesian Plane Geometry, 315
- Scouting for Boys, Lieut.-General R. S. Baden-Powell, 293
- Screw Propeller, Researches on the Performance of the, Prof. W. F. Durand, 416
- Sea-shore, the, shown to the Children, Janet Harvey Kelman, Frank Balfour Browne, 533
- Sea-water, Radio-activity of, J. Joly, 191
- Searchlights: their Theory, Construction, and Application, F. Noz, 260
- Sederholm (Mr.), Granite and Gneiss in Pre-Cambrian Complex of Fenno-Scandia, 184
- Sedgwick (Prof.), Relation between the Geographical Distribution and the Classification of the Onychophora, 478
- Sedgwick (Rev. S. N.), the Minimising of Maurice, being the Adventures of a very small Boy among very small Things, 508
- See (Dr. T. J. J.), Poseidonius on the Originator of the Theory of Atoms, 345; Mochus of Sidon and the Theory of Atoms, 541
- Seed and Soil Inoculation for Leguminous Crops, Prof. W. B. Bottomley, 330
- Seismology: the International Association of Seismology, 60; British Association Seismology, Prof. John Milne, F.R.S., 198; Seismographs and Seismograms, R. D. Oldham, 246; the Calabrian Earthquake of 1906, 251; Seismic Radiations, Dr. C. G. Knott, 335; Methods of Construction adopted in Re-building Calabrian Villages destroyed in the Earthquake of September 8, 1905, Prof. Mario Baratta, 468; Possibility of a Causal Connection between the Two Earthquakes on August 16, 1906, in the Northern Pacific and in Chile, Dr. E. Oddone, 468; Earthquakes, an Introduction to Seismic Geology, William Herbert Hobbs, 481; Recent Earthquakes, Prof. J. Milne, F.R.S., at Royal Institution, 592
- Selenium, the Photoelectric Property of, Prof. George M. Minchin, F.R.S., 173, 222; Richard J. Moss, 198; Dr. Shelford Bidwell, F.R.S., 198
- Selenium Photometer, Determination of the Moon's Light with a, J. Stebbins and F. C. Brown, 258, 302
- Sella (Prof. Alfonso), Death and Obituary Notice of, 133
- Sellers (Dr. Coleman), Death and Obituary Notice of, 325
- Selwyn-Brown (A.), Tin-mining Industry, World's Production of Tin Last Year, 157
- Senple (Miss E. C.), Geographical Boundaries, 64
- Senderens (J. B.), Catalytic Power of Silica and Alumina, 311
- Senier (A.), Attempted Synthesis of $\begin{matrix} \beta-N-\beta \\ | \\ \beta-CH-\beta \end{matrix}$ -dinaphacri-dine, 238
- Sero-therapy: Immune Sera, Dr. C. F. Bolduan, 411
- Sewage, Pollution of the Illinois and Mississippi Rivers by Chicago, Marshall O. Leighton, 68
- Sewage, Utilisation of Turf for the Purification of, A. Muntz and E. Laine, 287
- Sex, Mendelism and, G. Archdall Reid at Linnean Society, 236
- Share-Jones (John T.), the Surgical Anatomy of the Horse, 170
- Shaw (J. B.), Synopsis of Linear Associative Algebra, 603
- Shaw (Dr. W. N., F.R.S.), Obituary Notice of Sir Richard Strachey, K.C.S.I., F.R.S., 395
- Shaxby (John H.), Method of observing the "Subjective Yellow," 32
- Shenstone (W. A., F.R.S.), Death of, 324; Obituary Notice of, Prof. William A. Tilden, F.R.S., 348
- Shepard (Dr. William Kent), Problems in Strength of Materials, 365
- Shepherd (Rev. C. W.), Notes on the Birds of Kent, 511
- Sheppard (T.), British Chariot Burial discovered at Hun-manby, 180
- Sherrington (Prof. C. S., F.R.S.), Reciprocal Innervation of Antagonistic Muscles, 333; Nerve as a Master of Muscle, Discourse at Royal Institution, 569
- Sherzer (Dr. William Hittell), Glaciers of the Canadian Rockies and Selkirks (Smithsonian Expedition of 1904), 463
- Shipbuilding, Inter-relation of the Theory and Practice of J. J. O'Neill, 327
- Shorthorns, Mendelian Characters among, Prof. James Wilson, 500, 559; Prof. Karl Pearson, F.R.S., 559; Prof. John G. Kendrick, 582
- Shruball (Dr. F. C.), Notes on some Bushman Crania and Bones from the South African Museum, Cape Town, 211
- Sibley (T. F.), Faunal Succession in Carboniferous Lime-stone of Midland Area, 189
- Sidis (Dr. Boris), New Explanation of Hallucinations, 589
- Siebenrock (F.), a Monographic Revision of the American Tortoises of the Family Cheloniidae, 304
- Silberrad (O.), the Metallic Pincets, 383
- Silvered Mirrors, Temperature Control of, Dr. Heber D. Curtis, 137
- Simmonds (C.), India-rubber and its Manufacture, with Chapters on Gutta-percha and Balata, Hubert L. Terry, 206
- Simonin (M.), the Recent Transit of Mercury, 116
- Simpson (George C.), Auroral Characteristics of Clouds, 344
- Simroth (Dr. Heinrich), die Pendulations-theorie, 508

- Sinclair (James), a Second Year's Course in Practical Physics, 482; a Third Year's Course in Practical Physics, 482
- Singing Sand from New England, S. Skinner, 188
- Singrun (M.), the Audiifren Refrigerator, 215
- Sippel (Dr. W.), Structure of the Roof of the Mouth in Birds and Mammals, 155
- Sisson (H. A.), Action of Metallic Magnesium on Aliphatic Acids and the Detection of Formic Acid, 190
- Skinner (S.), Singing Sand from New England, 188; Musical Sands, 248
- Slade (R. E.), Reducibility of Magnesium Oxide by Carbon, 383
- Slater (R. C.), the Winding of Rivers in Plains, 79
- Slator (A.), the Mechanism of Alcoholic Fermentation, 335
- Sleeping Sickness: Connection between Crocodiles and, Prof. Koch, 16; the Cure and Prevention of, 36; Proceedings of the First International Conference on, held at London, June, 1907, 449; the Development of Trypanosomes in Tsetse-flies and other Diptera, Prof. E. A. Minchin, 494
- Slide-rules, New, Messrs. J. J. Griffin and Sons, 500
- Slipher (Mr.), Water Vapour in the Martian Atmosphere, 497
- Smalian (Prof. Karl), Grundzüge der Tierkunde für höhere Lehranstalten, 76; Grundzüge der Pflanzenkunde, 481; Anatomische Physiologie der Pflanzen und der Menschen, 481
- Smedley (Miss L.), Refractive Power of Diphenylhexatriene and Allied Hydrocarbons, 166
- Smiles (S.), the Sulphination of Phenolic Ethers and the Influence of Substituents, 502
- Smith (Bruce), an Annotated Copy of Newton's "Principia," 510
- Smith (Colonel F., C.B., C.M.G.), a Manual of Veterinary Physiology, 210
- Smith (F. E.), the Silver Voltmeter, 165; Chemistry of the Silver Voltmeter, 165; the Normal Weston Cadmium Cell, 165
- Smith (G. Le Blanc), Dragonisque Forms on, and beneath, Fomts, 156
- Smith (H. G.), the Australian Melaleucas and their Essential Oil, 480
- Smith (Mr.), Molasses as Cattle Food, 590-1
- Smith (Dr. Ramsay), Teeth of Australians, 64
- Smith (S. W. J.), Contact Potential Differences determined by Means of Null Solutions, 477; Thermomagnetic Analysis of Meteoric and Artificial Nickel-iron Alloys, 574
- Smith (Winifred), Anatomy of some Sapotaceous Seedlings, 598
- Smith (Worthington), Eolith Stone Implements, 615
- Smithsonian Expedition of 1904, Glaciers of the Canadian Rockies and Selkirks, Dr. William Hittell Sherzer, Prof. T. G. Bonney, F.R.S., 463
- Smithsonian Institution, the, 357
- Snelling (W. O.), the Waste of Life in American Coal-mining, 419
- Society of Chemical Industry, 118, 180, 263, 382, 598
- Soddy (Frederick), the Wehnelt Kathode in a High Vacuum, 53, 197
- Soddy (F.), Electrical Discharge in Monatomic Gases, 310
- Soil-geology of Ireland, a Description of the, based upon Geological Survey Maps and Records, with Notes on Climate, J. R. Kilroe, 4
- Solá (J. Comas), Observation of the Transit of Mercury of November 14, 1907
- Solar Eclipse of January 3, 1908, the Total, Dr. W. J. S. Lockyer, 104, 274
- Solar Eclipse of August, 1905, Spanish Observation of the Total, 446
- Solar Prominence, a Large, Dr. A. A. Rambaut, 66
- Solar Prominence of May 21, 1907, the Large, Father Fényi, 446
- Solar Prominences in 1906, Prof. Ricco, 138
- Solar Spectroscopy, the Objective Prism in, E. Schaer, 401
- Solar Spectrum: the Helium Line, D., as a Dark Line in the, A. A. Buss, 377; the Helium, D₃, Line in the Solar Spectrum, Captain Daunt, 520
- Solidification of Helium, the, Prof. Alfred W. Porter, 437
- Sollas (Prof. W. J.), on the Cranial and Facial Characters of the Neanderthal Race, 262
- Solomon (John J.), Radiography in Pearl Fishing, 331
- Solomon's Temple: its History and Structure, Rev. W. Shaw Caldecott, Supp. to March 5, x
- Somerville (Prof. W.), Heredity and Forestry, 279
- Sorby (Dr. H. C., F.R.S.), on the Colouring Matters of Flowers, 260; Application of Quantitative Methods to the Study of the Structure and History of Rocks, 334; Best Means of preserving Marine Invertebrates for Museum Purposes, 375
- Sorby (Dr. H. C., F.R.S.), Death of, 443; Obituary Notice of, 495
- Sound: the New Matriculation Sound, 482
- South (Richard), the Moths of the British Isles, 483
- Southern Hemisphere, a New Expedition to the, 544
- Southwell (T.), the Arctic Whaling Voyage of Last Year, 417
- Spanish Observation of the Total Solar Eclipse of August, 1905, 446
- Specific Gravity Balance for Large Rock Specimens, a, T. H. D. la Touche, 221
- Spectroscope, Echelon, H. Stansfield, 198, 222
- Spectrum Analysis: Method of Observing the "Subjective Yellow," John H. Shaxby, 32; Ultra-violet Region in Sun-spot Spectra and Spectrum of Comet d 1907, J. Evershed, 44; Binocular Diffraction Spectroscopy, Dr. Marshall Watts, 115; Orbits of Spectroscopic Binaries, Dr. Curtis, 138; Presence of Sulphur in some of the Hotter Stars, Sir Norman Lockyer, K.C.B., F.R.S., 141; Spectroscopic Determination of the Rotation of the Sun, Prof. Adams, 158; Newly Discovered Spectroscopic Binaries, A. B. Turner, 158; Stars having Peculiar Spectra, Mrs. Fleming, 158; Weakened Lines in Sun-spot Spectra, Nagaraja, 158; Sun-spot Spectra, Prof. W. S. Adams, 421; Charles M. Olmsted, 421; Apparatus designed for Stars composed partly of Gas and partly of Solid Particles, H. Deslandres, 167; Apparatus for the Production of Spark Spectra of Solutions, A. de Gramont, 168; Provisional Elements for the Spectroscopic Binary α Andromedæ, Dr. H. Ludendorff, 182; Absorption Spectra of Collidine and α -Chlorocollidine, J. E. Purvis and W. H. Foster, 190; Flame Spectra obtained by the Electrical Method, G. A. Hensalech and C. de Wateville, 215; the Spectra of Two Meteors, M. Blakjok, 234; the Constancy of Wave-lengths of Spectral Lines, Prof. Kayser, 234; an Early Acoustical Analogue of Michelson's Echelon Grating, Prof. P. Zeeman, 247; Intensity of Spectrum Lines, A. D. Cowper, 248; on the Colouring Matters of Flowers, Dr. H. C. Sorby, F.R.S., 260; the Absorption Spectrum of Protochlorophyll, N. A. Monteverde, 270; the Absorption of D₃ (Helium) in the Neighbourhood of Sun-spots, Father Cortie, 281; the Helium Line, D₂, as a Dark Line in the Solar Spectrum, A. A. Buss, 377; the Helium, D₃, Line in the Solar Spectrum, Captain Daunt, 520; the Orbit of the Spectroscopic Binary θ Aquilæ, W. E. Harper, 281; Cause of the Slight Variability of Wave-length of Spectral Lines, Prof. F. Exner and Dr. E. Haschek, 304; the Recent Spectrum and Magnitude of Nova Persei No. 2, Prof. Hartmann, 377; the Objective Prism in Solar Spectroscopy, E. Schaer, 401; a Fundamental Contradiction between the Electrical Theory of Dispersion and the Phenomena of Spectrum Series, Dr. G. A. Schott, 413; the Spectrum of the Aurora Borealis, Dr. W. Marshall Watts, 421; the Flame Spectra of Metals, Drs. Hensalech and de Wateville, 446; Spectrum of the Discharge from a Glowing Line Kathode in Mercury Vapour, F. Horta, 454; the Two-fold Line Spectra of Chemical Elements, E. Goldstein, 460; Measurements of the Zeeman Effect for the Principal Lines of Helium, Dr. W. Lohmann, 470; Two Remarkable Spectroscopic Binaries, Mr. Gore, 520; Absorption Spectra of Crystals of the Rare Earths in a Magnetic Field at the Temperatures of the Liquefaction and Solidification of Hydrogen, Jean Becquerel and H. Kamerlingh Onnes, 527; Lines presenting a Zeeman Phenomenon abnormal in the Sense of the Magnetic Lines of Force, A. Dufour, 527; Presence of Spark Lines in the Arc Spectrum, Ch. Fabry and H. Buisson, 576; Satellites of Yellow and Green Lines of Mercury, Prof. H. Nagaoka, 581; Effect of Pressure on the Wave-lengths of the Absorption Lines of Nitrogen Peroxide and Bromine, A. Dufour, 589;

- Spectroscopic Binaries now under Observation, Prof. Frost, 590; Prof. Hartmann, 590; Prof. Pickering, 590; Magnetic Resolution of Spectral Lines and Magnetic Force, Prof. P. Zeeman, 615; Flame Spectra of Iron, G. A. Hemsalech and C. de Wauville, 623; the Presence of Water Vapour in the Atmosphere of Mars, Prof. Percival Lowell, 606; the Theory of Dispersion and Spectrum Series, Norman R. Campbell, 607
- Speech, the Mechanism of, Alexander Graham Bell, Prof. John G. Kendrick, F.R.S., 483
- Speech and Song, Voice Training in, H. H. Hulbert, 317
- Speed of Racing Animals, the, Prof. John Perry, F.R.S., 389
- Spence (Dr. D.), the Insoluble Constituent of Para Rubber, 180
- Spencer (J. F.), the Direct Interaction of Aryl Halides and Magnesium, 239; Quantitative Separation of Thallium from Silver, 551
- Spencer (L. J.), Hopeite and other Zinc Phosphates from Broken Hill Mines, 143
- Spicer (Rev. E. C.), the Inheritance of "Acquired" Characters, 247, 342
- Spitta (E. J.), Microscopy: the Construction, Theory, and Use of the Microscope, 314
- Spring (Prof. Walthère), the Allotropic Forms of Sulphur, 327
- Springer (Frank), Genera of *Crinoida flexibilia*, 117
- Stability in Flight, A. Mallock, F.R.S., 293; Major B. Baden-Powell, 320; Herbert Chatley, 320
- Standard Time in Egypt, Distribution of, Capt. H. G. Lyons, 497
- Stansbie (J. H.), Iron and Steel, 579
- Stansfield (H.), Echelon Spectroscope, 198, 222
- Stanton (Dr. J. E.), Experiments on Wind-pressure, 139
- Stapes, the Function of, the, 289
- Staples-Browne (R.), the Inheritance of Colour in Domestic Pigeons, with Special Reference to Reversion, 430
- Stark (Prof. J.), the Wave-length of Röntgen Rays, 320
- Stars: Red Stars near Nova Velorum, Mrs. Fleming, 42; the Orbit of the Spectroscopic Binary θ Aquilæ, W. E. Harper, 281; Measures of Double Stars, C. P. Olivier and R. E. Wilson, 281; Two Hundred New Double Stars, Prof. Aitken, 328; the Accuracy of Double Star Measures, Prof. Döberck, 328; Stars having Peculiar Spectra, Mrs. Fleming, 158; Nova Persei, 1901, Prof. Barnard, 182; the Recent Spectrum and Magnitude of Nova Persei, No. 2, Prof. Hartmann, 377; Provisional Elements for the Spectroscopic Binary α Andromedæ, Dr. H. Ludendorff, 182; the Distortion of Photographic Films in Stellar Work, Dr. Frank Schlesinger, 328; Forty-one New Variable Stars, 329; a Catalogue of Zodiacal Stars, H. B. Hedrick, 353; the Variable Star 31, 1907, Aurigæ, Prof. Hartwig, 471; the Dispersion of Light in Interstellar Space, Dr. C. Nordmann, 497; Dr. Nordmann's Variable Star Observations, 520; Meridian Circle Observations of Parallax Stars, 544; Two Remarkable Spectroscopic Binaries, Mr. Gore, 520; the Recent Maximum of Mira Ceti, Félix de Roy, 544; Observations of Eros, G. Van Biesbroeck, 590; Variable Radial Velocity of η Virginis, W. E. Harper, 590; Spectroscopic Binaries now under Observation, Prof. Frost, 590; Prof. Hartmann, 590; Prof. Pickering, 590; the Relations between the Colours and Periods of Variable Stars, S. Beljajsky, 590; the Children's Book of Stars, G. E. Mitton, 605; a New Star-finder, C. Baker, 616; Systematic Motions of the Stars, Prof. Dyson, 616
- Starvation, the Scientific Study of, 610
- Statics: Elementary Statics, W. P. Borchardt, 315; a First Statics, C. S. Jackson and R. M. Milne, 555
- Statistics: Statistics of Insanity and Inheritance of Insane Diathesis, David Heron, 179; Relations between Mortality of Infants and High Temperatures, Dr. E. Van Everdingen, 206; Drapers' Company Research Memorials, ii, a First Study of the Statistics of Pulmonary Tuberculosis, Prof. Karl Pearson, F.R.S., 394
- Status of Lamarck, the International Memorial, Sir E. Ray Lankester, K.C.B., F.R.S., 149
- Steam and other Engines, J. Duncan, 20
- Stebbing (E. P.), Insects Injurious to Sal-forests of Assam, 587
- Stebbing (Rev. T. R. R.), South African Crustaceans, 613
- Stebbins (Dr. Joel), Double-star Observations, 401
- Stebbins (J.), Determination of the Moon's Light with a Selenium Photometer, 238, 302
- Steché (Dr.), Two Luminous Fishes from the Malay Archipelago, 15
- Steel: les Aciers spéciaux, L. Revillon, 317; Iron and, J. H. Stansbie, 579
- Steele (Dr. Bertram D.), Electrolysis of Salt Solutions in Liquefied Sulphur Dioxide, 47
- Steinmann (Gustav), Einführung in die Paläontologie, 558
- Stejneger (L.), Herpetology of Japan and Adjacent Territory, 91
- Stephenson (A.), New Type of Dynamical Stability, 359
- Stephenson (J. H. N.), the Elements of Geography, 484
- Stereoscopy: a New Method of Stereoscopic Photography, Prof. G. Lippmann, 452; die binokularen Instrumente, Moritz von Kohr, Supp. to March 5, iv
- Stimulus and Response, Physiological, Supp. to March 5, iii
- Stock Frost or Ground Ice, Rev. John J. Hampson, 295; James Thomson, 566; Prof. H. T. Barnes, 412
- Stokes (E. M.), the Direct Interaction of Aryl Halides and Magnesium, 239
- Stokey (Miss A. G.), Roots of *Lycopodium pithyoides*, 64
- Stolyhwo (K.), Human Skull from the Historic Period presenting Indications of Close Affinity with the Spy-Neanderthal Type, 587
- Stoney (Dr. G. Johnstone), the Habitability of Mars, 461
- Stożir (Prof. Ivan), Death of, 397
- Strachan (R.), Indications of Approaching Frost, 188
- Strachey (Lieut.-General Sir Richard, G.C.S.I., F.R.S.), Death of, 373; Obituary Notice of, Dr. W. N. Shaw, F.R.S., 395
- Strasburger (Prof. E.), Some Scientific Centres, xii., the Botanical Institute of the University of Bonn, 321
- Stratford (Prof. W.), Death and Obituary Notice of, 374
- Stream Surfaces and Equipotentials, Freehand Graphic Way of determining, L. F. Richardson, 118
- Strecker (Dr. Friedrich), das Kausalitätsprinzip der Biologie, 507
- Strengers (Th.), Explosive Rhodium, 519
- Strength of Materials, W. C. Poplewell, 412
- Strength of Materials, Problems in, Dr. William Kent Shephard, 365
- Stresses in Masonry Dams, an Experimental Study of, Karl Pearson, F.R.S., A. F. Campbell Pollard, C. W. Wheen, and L. F. Richardson, Prof. E. Brown, 209
- Stresses in Masonry Dams, the, H. M. Martin, 269, 320, 302; Sir Oliver Lodge, F.R.S., 269; Prof. Karl Pearson, F.R.S., 269, 366; Sir John W. Ottley, K.C.I.E., and Dr. A. W. Brightmore, J. S. Wilson and W. Gore, at Institution of Civil Engineers, 303
- Stromeyer (C. E.), the Isothermal Layer of the Atmosphere, 485
- Strong (W. W.), the Penetrating Radiation, 343
- Stroobant (Prof. P.), les Progrès de la Photographie astronomique, 508
- Structure of the Corona, Prof. Hansky, 590
- Strutt (Hon. R. J., F.R.S.), Association of Helium and Thorium in Minerals, 141; Radium and the Earth's Heat, 365
- Stücker (Dr. N.), the Sensitiveness of Many Persons to Small Differences of Pitch, 304
- Sturge (Dr. Mary D.), Alcohol and the Human Body, 387
- "Subjective Yellow," Method of Observing the, John H. Shaxby, 32
- Suess (Prof.), Peculiarities in the Structure of some Heavenly Bodies, 490
- Sugar-canes, Disease-resisting, Sir D. Morris, K.C.M.G., 438
- Sulphur as an Insulator, Rev. F. J. Jervis-Smith, F.R.S., 149
- Sun: Spectroscopic Determination of the Rotation of the, Prof. Adams, 158; a Useful Sun and Planet Chart, 302; the Sun and the Clock, 372; the Recent Total Solar Eclipse, 544; Structure of the Corona, Prof. Hansky, 590
- Sun-spot Observations, T. Epstein, 544
- Sun-spot Spectra, Weakened Lines in, Mr. Nagaraja, 158
- Sun-spot Spectra, Prof. W. S. Adams, 421; Charles M. Olmsted, 421

- Sun-spots, the Absorption of D₃ (Helium) in the Neighbourhood of, Father Cortie, 281
- Sunshine and Sport in Florida and the West Indies, F. G. Allain, 128
- Surgery: Death of Dr. Thomas Annandale, 178
- Surgical Anatomy of the Horse, the, John T. Share-Jones, 170
- Surveying: Road-making and Maintenance, Thomas Aitken, 244
- Surveys of Nebulae, P. Gotz, 90
- Sutton (A. W.), Brassica Crosses, 334; Wild Types and Species of the Tuber-bearing Solanums, 479
- Sutton (J. R.), the Supposed Cloud-dispersing Power of the Full Moon, 518
- Swain (R. E.), the Smoke from Metallurgical Works, 376
- Swinton (A. A. Campbell), Formation of Gas Bubbles in the Glass of Vacuum Tubes, 374; the Conversion of Diamond into Coke in High Vacuum by Kathode Rays, 549
- Sykes (Major), Find of Bronze Weapons, Implements, and Vessels at Khinaman, South-east Persia, 139
- Systematic Motions of the Stars, Prof. Dyson, 616
- Tabata (S.), Microchemical Examination of Fruits of *Rhus succedanea*, 279
- Tabernacle, the, its History and Structure, Rev. W. Shaw Caldecott, Supp. to March 5, x
- Talbot (A. N.), Tests of Reinforced Concrete Beams, 232
- Tammes (I.), Stem of the Flax Plant, 445
- Tancredi (Captain), Climate of Eritrea, 88
- Tanner (Mr.), Glacial Phenomena of Finmark, 185
- Tasmania, Nests and Eggs of Birds found breeding in Australia and, A. J. North, 76
- Tassin (Wirt), the Canyon Diablo Meteorites, 208
- Taylor (Rev. C. S.), Martinmas in May, 510
- Taylor (E. R.), the Production in the Electric Furnace of Carbon Bisulphide, 519
- Taylor (T. U.), Underground Waters of the Costal Plain of Texas, 68
- Teall (J. J. H.), the Geological Structure of the North-west Highlands of Scotland, Petrological Notes, 272
- Technical Research and the College System, W. P. Dreaper, 367
- Technology: Modern Science and American, 49; Chapters on Paper-making, Clayton Beadle, 121
- Telegraphy: Wireless Telegraphy Apparatus on board French Warships, 62; Magnetic Oscillators as Radiators in Wireless Telegraphy, Dr. J. A. Fleming, 71; the Use of Variable Mutual Inductances, A. Campbell, 71; New Transatlantic Wireless Station at Knokkroe, the Poulsen System of Wireless Telegraphy by Undamped Waves, 88; Determination of the Time, both on Land and at Sea, with the Aid of Wireless Telegraphy, Bouquet de la Grye, 551; Jahrbuch der drahtlosen Telegraphie und Telephonie, Supp. to March 5, ix
- Telephony: Propagation of Telephone Currents through Subterranean Lines, Henri Abraham and M. Devaux-Charbonnel, 767; Conditions of Maximum Yield for Telephonic Apparatus, Henri Abraham and M. Devaux-Charbonnel, 215; Telephoning without Wires, Valdemar Poulsen, 587; Jahrbuch der drahtlosen Telegraphie und Telephonie, Supp. to March 5, ix; Wireless Telephony in Theory and Practice, E. Ruhmer, Supp. to March 5, ix
- Telescopes: the Systematic Error of Latitude observed with a Zenith Telescope, Herr Battermann and K. Hirayama, 42; the Appearance of Neptune in Small Telescopes, Mr. Holmes, 258; Mr. Maw, 258
- Tellurian, the "Day by Day," Messrs. G. Philip and Son, 127
- Tenpány (H. A.), the Keeping Power of Fehling's Solution, 203
- Temperature Control of Silvered Mirrors, Dr. Heber D. Curtis, 157
- Terroine (E.), Influence of the Reaction of the Medium on the Size of the Colloidal Granules, 110
- Terry (Hubert L.), India-rubber and its Manufacture, with Chapters on Gutta-percha and Balata, 296
- Theobald (Fred. V.), the Story of Insect Life, W. P. Westell, 175
- Therapeutics: Therapeutics of Trypanosomes, A. Laveran and A. Thiroux, 47; New Treatment for Consumption, 254
- Thermodynamics: Experimental and Theoretical Applications of Thermodynamics to Chemistry, Dr. Walther Nernst, 52; a Convenient Formula in Thermodynamics, Harvey N. Davis, 80; Lehrbuch der theoretischen Elektrochemie auf thermodynamischer Grundlage, J. J. van Laar, 389
- Thévenot (L.), Characters of Tuberculous Infection in their Relations with the Diagnosis of Tuberculosis, 503
- Thiroux (A.), Therapeutics of Trypanosomes, 47
- Thielsen-Dyer (Sir W. T., K.C.M.G., F.R.S.), Specific Stability and Mutation, 77, 127; Mulatto, 129
- Thomälen (Dr. Adolf), a Text-book of Electrical Engineering, 124
- Thomas (F.), Analysis of Indigo, 118
- Thomas (Hugh H.), the Structure of *Sigillaria scutellata*, 549
- Thomas (H. H.), Metamorphic Minerals in Calcareous Rocks in the Bodmin and Camelford Areas, 574
- Thomas (N. W.), "Grave Stones" from New South Wales, 94
- Thomas (V.), Derivatives of Thiophene, 528
- Thompson (Dr. Ashburton), the Interdependence of the Rat and Plague, 113; Protection of India from Plague, 133
- Thompson (Prof. Silvanus P., F.R.S.), Obituary Notice of Lord Kelvin, 175
- Thomson (Elihu), Global Lightning, 178
- Thomson (James), Ground Ice, 366
- Thomson (J. D.), Experimental Treatment of Trypanosomiasis in Rats, 238
- Thomson (Prof. J. J., F.R.S.), the Nature of γ -Rays, 451; Velocity of Kathodic Secondary Radiation, 454; the Corpuscular Theory of Matter, 505
- Thornton (Mr.), the Tuberculin Test for Cattle, 213
- Thorpe (Prof. T. E., C.B., F.R.S.), the Centenary of Davy's Discovery of the Metals of the Alkalies, Lecture at Royal Institution, 305
- Thoulet (J.), Possible Presence of Microscopic Diamonds on the Sea-floor and in a Specimen of Vegetable Earth, 407
- Tiechurst (Mr.), Spread of the Little Owl in England, 564
- Tiechurst (N. F.), Bird-bones from Broch of Ayre, Orkney, 467
- Tidal Investigations in Canada, W. Bell Dawson, 202
- Tiddeman (Mr.), Pre-glacial Raised Beach traced from Mumbles Head westward, 184
- Tierkunde, Grundzüge der, für höhere Lehranstalten, Prof. Karl Smalian, 76
- Tiffeneau (Marc), Mechanism of the Transposition of the Phenyl Group in the Iodohydrins and Aromatic Glycols, 263
- Tilden (Prof. William A., F.R.S.), Obituary Notice of W. A. Shenstone, F.R.S., 348
- Till (Dr. A.), Examples found in the Neocomian, 184
- Tillyard (R. J.), Dragon-flies from Central Australia, 192; Australian Genus *Petalura* Dragon-fly, 192; the Dragon-flies of South-western Australia, 192
- Time Distribution, Public Clocks and, 253
- Tin-mining Industry, World's Production of Tin Last Year, A. Selwyn-Brown, 157
- Tischbrock (L. M. de la Motte), der Neue Leitfaden, 268
- Tissot (C.), Correction of the Astigmatism of Doubly Refracting Prisms, 95
- Todd (Sir Charles), Meteorological Observations in South Australia and the Northern Territory during 1905, 352
- Todd (R. A.), the Food of Fishes, 524
- Tonge (James), Coal, 389
- Topography of the Air, Possibilities of a, based on Balloon Observations, Capt. C. H. Ley, 188, 566
- Town Gas and its Uses for the Production of Light, Heat, and Motive Power, W. H. Y. Webber, 340
- Traction, Electric, Prof. Ernest Wilson and Francis Lydall, Gisbert Kapp, 169
- Transmissibilité de Caractères acquis, sur la, Eugenio Rignano, 103
- Transpiration and Anatomical Structure in Tropical Plants, 313

- Transplantation, Regeneration and, Prof. E. Korschelt, 99
Transvaal Biological Society, 576
Transvaal Mines Department, Report of the Geological Survey for the Year 1906, Dr. F. H. Hatch, 346
Traquair (Dr. R. H., F.R.S.), Dr. Edward Sang's Collection of M.S. Calculations in Trigonometry and Astronomy, 13
Travers (Dr. Morris W., F.R.S.), the Victoria Jubilee Technical Institute, Bombay, 31; the Condensation of Helium, 606
Trees: Étude sur les Foudroiements d'arbres constatés en Belgique pendant les Années 1884-1906, E. Vanderlinden, 197; Worms and Tree-planting, E. A. Andrews, 205; Trees and their Life-histories, Prof. F. Groom, 538
Treloar (A.), the Separation of Tin-oxide from Wolfram, 119
Trent, the Shaping of Lindsey by the, F. M. Burton, 371
Trigonometry: Dr. Edward Sang's Collection of M.S. Calculations in Trigonometry and Astronomy, Dr. R. H. Traquair, F.R.S., 13; Elementary Trigonometry, C. Hawkins, 315
Trillat (A.), Formation of Acetic Aldehyde in Alcoholic Fermentations, 528
Trituberculosis: Evolution of Mammalian Molar Teeth, to and from the Triangular Type, H. F. Osborn, 435
Trowbridge (Prof.), the Study of Meteor Trains, 328
Trypanosomiasis in Rats, Experimental Treatment of, H. G. Plimmer and J. D. Thomson, 238
Tuberculosis: New Method of Reaction of the Skin to Tuberculosis and its Utilisation in Diagnosis, J. Lignières, 23; Influence of Feeding on the Course of Experimental Tuberculosis, MM. Lannelongue, Achard, and Gaillard, 95; the Tuberculin Test for Cattle, Mr. Bruce, 213; Mr. Thornton, 213; Drapers' Company Research Memoirs, ii., a First Study of the Statistics of Pulmonary Tuberculosis, Prof. Karl Pearson, F.R.S., 394; Characters of Tuberculous Infection in their Relations to the Diagnosis of, S. Arloing and L. Thévenot, 503; Sanatoria for Consumption, Dr. R. Fielding-Ould, 546
Turnbull (V. M.), Arithmetic for Schools, 27
Turneaure (F. E.), Principles of Reinforced Concrete Construction, Supp. to March 5, vi
Turner (A. B.), Newly Discovered Spectroscopic Binaries, 158
Turner (Drsydale), Life-history of the Warble-flies *Hypoderma lineata* and *H. bovis*, 279
Turner (Emma L.), Home-life of some Marsh-birds, 393
Tutin (F.), Interaction of Methylene Chloride and the Sodium Derivative of Ethyl Malonate, 94; the Root and Leaves of *Morinda longiflora*, 94; the Melting Point of *d*-Phenylglucosazone, 94
Twiss (D. F.), a Course of Practical Organic Chemistry, 74

Uchiyama (M.), Influence of Stimulating Compounds on Crops, 376
Ultra-violet Light, Ionisation of Air by, Frederic Palmer, jun., 582
Underwood (Prof. L. M.), Death and Obituary Notice of, 62
United States, Hydrology in the, 68, 404
Universities: University and Educational Intelligence, 21, 45, 69, 92, 117, 140, 163, 187, 214, 237, 261, 286, 309, 332, 357, 381, 404, 428, 452, 475, 501, 525, 548, 572, 597, 621; the Increased Endowment of Universities, 152; Lord Kelvin and the University of Glasgow, 200; Extensions at University College, London, 525
Uranus, Occultations of, in 1908, 353
Urbain (G.), a New Element, Lutecium, 48; Compounds of Terbium and Dysprosium, 311; Lutecium and Neoytterbium, 432
 ζ Urse Majoris, the System of (Mizar), Prof. Frost, 471
 β Urse Majoris, Variation in the Radial Velocity of, Dr. H. Ludendorff, 520
Urwick (W. E.), the Child's Mind: its Growth and Training, 410
Urzeugung, die Lösung des Problems der, (Archigonia, Generatio spontanea), Martin Kuckuck, 29
Ussher (Mr.), Geology of the Country around Plymouth and Liskeard, 495

Vacuum, the Wehnelt Kathode in a High, Frederick Soddy, 53, 197; Prof. O. W. Richardson, 197
Vaillant (Charles), Possibility of establishing the Diagnosis of Death by Radiography, 96
Vaillant (P.), Velocity of Evaporation and a Method of Determining the Hygrometric State, 503
Valeur (Amand), Isopartheine, 216
Valentine (E. J.), Mining Tables, 317
Van der Waals and his Successors, 387
Van Nostrand's Chemical Annual, 1907, 267
Vanderlinden (E.), Études sur les Foudroiements d'arbres constatés en Belgique pendant les Années 1884-1906, 197
Variable Radial Velocity of η Virginis, W. E. Harper, 590
Variable Stars: Final Designations of Recently Discovered Variables, 90; Forty-one New Variable Stars, 329; a New Variable of the U Geminorum Type, Prof. Hartwig, 446; the Variable Star, 31, 1907, Aurige, Prof. Hartwig, 471; Variable Star Observations, Dr. Nordmann's, 520; the Relations between the Colours and Periods of, S. Beljawsky, 590
Variation in the Radial Velocity of β Urse Majoris, Dr. H. Ludendorff, 520
Variation: Specific Stability and Mutation, Sir W. T. Thelston-Dyer, K.C.M.G., F.R.S., 77, 127; R. H. Lock, 127
Vaughan (Dr. A.), the Carboniferous Rocks at Lough-shinny, 527
Vaughan (T. Wayland), Recent Madreporaria of the Hawaiian Islands and Laysan, 499
Vegetation der Erde, die, vii., die Pflanzenwelt von West Australien südlich des Wendekreises, Dr. L. Diels, 171
Veitch (James Herbert), Death and Obituary Notice of, 86
Velenovsky (Dr. Jos.), Vergleichende Morphologie der Pflanzen, 76
Veley (Miss L. L.), Luminous Barn-owls, 299
Veley (V. H.), Affinity Constants of Bases determined by the Agency of Methyl Orange, 166; Hydrolysis as illustrated by Heats of Neutralisation, 454
Venus, Recent Observations of, J. M. Harg, 471
Vertebrate Fauna of Patagonia, the Extinct, 68
Vertebrates, the Nervous System of, Prof. J. B. Johnston, Dr. W. Page May, 73
Verworn (Prof. Max), Physiologisches Praktikum für Mediziner, 148; die Mechanik des Geisteslebens, 556
Veterinary Physiology, a Manual of, Colonel F. Smith, C.B., C.M.G., Dr. Percy T. Herring, 219
Veterinary Surgery: the Tuberculin Test for Cattle, Mr. Bruce, 213; Mr. Thornton, 213
Victoria Jubilee Technical Institute, Bombay, the, Dr. Morris W. Travers, 31
Vignon (Léon), Carbon Monoxide in Coal Gas, 168
Viguier (M.), γ -Oxytetrolic Acid, 384
Vincart (P.), Observations of Jupiter during the Present Opposition, 471
Vincent (M. J.), the Balloon Ascent of July 25, 1907, 445
Viole (J.), Machines for Driving Away Hail, 455
 γ Virginis, the Orbit of, Dr. Doberck, 446
 η Virginis, Variable Radial Velocity of, W. E. Harper, 590
Viscosité des Liquides et des Gaz, Leçons sur la, Marcel Brillouin, 341
Vision, Problems of, 193
"Vitascope," the, Newton and Co., 233
Viticulture: Production of Grapes without Pips, Lucien Daniel, 48
Vogl (Sebastian), die Physik Roger Bacos, 268
Voice Training in Speech and Song, H. H. Hulbert, 317
Voiekkoff (A. I.), Distributions of Populations of the Earth in Dependence upon Natural Conditions and the Activity of Man, 498
Voit (F. W.), Kimberlite Dykes and Pipes, 224; the Origin of Diamonds, 224
Volcanoes: Disappearance of McCulloch Peak, Bogoslof Island, Lieut. B. H. Camden, 86; Vesuvius again Active, 230; Report on the Eruptions of the Soufrière in St. Vincent in 1902, the Changes in the Districts and the Subsequent History of the Volcanoes, Dr. Tempest Anderson, 549
Voorhes (Dr. Edward B.), Forage Crops for Soiling, Silage, Hay, and Pasture, 388

- Wade (E. B. H.), a Field Method of Determining Longitudes, 590
- Wagenen (I. F. Van), Product of the World's Gold Mines for the Year 1906, 280
- Wahl (A.), Derivatives of Phenylisoxazolone, 527
- Wales, Archaeological Remains in, and the Marches, 227
- Wales, Astronomy in, 421
- Walker (C. E.), Life-history of Leucocytes, Part ii., on the Origin of the Granules, Part iii., Phenomena occurring in Leucocytes, 71
- Walker (Charles Edward), the Essentials of Cytology, 410
- Walker (H.), Glaciers in Lahaul, 201
- Wallace (Dr.), Age and Growth-rate of Plaice in the Southern North Sea determined by the Otolith, 523
- Wallace (Dr. Alfred Russel, F.R.S.), Is Mars Habitable? a Critical Examination of Prof. Lowell's Book, "Mars and its Canals," with an Alternative Explanation, 337
- Walter (Dr. B.), Classification of Secondary X-Radiators, 462
- Walter (Dr. Heinrich), Phenomena occurring when Soda is Causticised by Means of Lime, 304
- Wanning (H.), Meteors Observed on January 2, 353
- Warburg (E.), Chemical Changes occurring when Air is submitted to the Influence of Electricity, 41
- Ward (Dr. H. A.), the Williamette Meteorite, 12; the Bath Furnace Aërolite, 12
- Ward (J. J.), Some Nature Biographies: Plant, Insect, Marine, Mineral, 147
- Ward (Prof. R. De C.), Problems of the Tropics, 542
- Warth (H.), Method of Ice-making from Pure Water in Winter, 518
- Wasp, a Miocene, Prof. T. D. A. Cockerell, 80
- Water, Clean, and How to Get It, Allen Hagen, 218
- Water Vapour in the Martian Atmosphere, William E. Rolston, 442; Mr. Slipher, 497; Prof. Lowell, 503, 506
- Waters (C. E.), Investigation on the Clark and Weston Standard Cells, 280
- Waterston (Dr. D.), Growth and Development of the Limbs of the Penguin, 407
- Watson (D. M. S.), (1) the Cone of Bothrodendron mundum (Will), (2) on the Ulodendroid Scar, 191
- Watson (H. E.), Recalculation of Atomic Weights, 7
- Watt (Sir G.), the Wild and Cultivated Cotton Plants of the World, a Revision of the Genus *Gossypium*, 241
- Watteville (C. de), Flame Spectra obtained by the Electrical Method, 215; the Flame Spectra of Metals, 446; Flame Spectra of Iron, 623
- Watts (Dr. Francis), the Keeping Power of Fehling's Solution, 263
- Watts (Dr. Marshall), Binocular Diffraction Spectroscopy, 115; the Spectrum of the Aurora Borealis, 421
- Wave-length of Röntgen Rays, the, Prof. J. Stark, 320
- Wave-lengths of Spectral Lines, the Constancy of, Prof. Kayser, 234
- Way (E. J.), Labour-saving Appliances in Transvaal Mines, 114
- Weakened Lines in Sun-spot Spectra, Mr. Nagaraja, 158
- Weathering Phenomena in Building Stones, E. Kaiser, 181
- Webb (W. M.), the Heritage of Dress, being Notes on the History and Evolution of Clothes, Supp. to March 5, vii
- Webber (W. H. Y.), Town Gas and its Uses for the Production of Light, Heat, and Motive Power, 340
- Webber (Dr. C. A.), the Production of a Moor, 87
- Weber (H. C. P.), Re-determination of the Atomic Weight of Chlorine, 543
- Wegscheider (Prof. Rudolph), Phenomena occurring when Soda is Causticised by Means of Lime, 304
- Wehnelt Kathode in a High Vacuum, the, Frederick Soddy, 53, 197; Prof. O. W. Richardson, 197
- Weights and Measures: the Metric and British Systems of Weights, Measures, and Coinage, Dr. F. Mollwo Perkin, 77; a Series of Standard Weights and Measures for Securing Uniformity in Scientific Papers, 114; Weights and Measures of International Commerce, 317; les récents Progrès du Système métrique, Ch.-Ed. Guillaume, 611
- Weiss (Prof.), Search-ephemeris for Comet 1907a (Giacobini), 138; Comet 1907 II., 520
- Weiss (Prof. F. E.), Immunity to Disease among Plants, Address at British Pharmaceutical Conference at Manchester, 20; the Morphology of *Stigmara* and of its Appendages in Comparison with Recent Lycopodiales, 477
- Wess (P.), Comparison of the Energy Losses due to Hysteresis in Iron, Steel, and Nickel, in Alternating and Rotating Magnetic Fields respectively, 327
- Welch (Dr. W. H.), the Interdependence of Medicine and other Sciences, Address at Chicago Meeting of American Association, 283
- Wells (H. G.), Mulattos, 149
- Wendt (Dr. Johannes), the Saturn Perturbations of Various Comets, 568
- Werndly (Dr. L. U. H. C.), an Optical Illusion, 31
- Wertheimer (Prof. J.), Continuation Schools in England and Elsewhere, 361
- Wesbraat (Mr.), the Quality of Surface Waters in Minnesota, 68
- West Indies, Sunshine and Sport in Florida and, F. G. Aflalo, 128
- West (Prof. C. D.), Death of, 254
- West (Lionel F.), the Climber's Pocket Book, Rock-climbing Accidents, with Hints on First Aid to the Injured, some Uses of the Rope, Methods of Rescue, and Transport, 196
- Westell (W. P.), the Story of Insect Life, 175
- Western (F. E.), a Scheme for the Detection of the More Common Classes of Carbon Compounds, 74
- Westlake (Rev. H. F.), Constructions in Practical Geometry, 148
- Weston (F. E.), Action of Aluminium Powder on Silica and Boric Anhydride, 47
- Whaling Voyage of Last Year, the Arctic, T. Southwell, 417
- When (C. W.), an Experimental Study of Stresses in Masonry Dams, 209
- Wheldon (J. A.), the Flora of West Lancashire, 194
- Whipple (F. J. W.), Graphical Interpolation, 103
- White (H. J. Osborne), the Geology of the Country around Hungerford and Newbury, 90
- White (M.), Meteorological Observations at the British Kite Stations, Session 1906-7, 188
- White (W. P.), Potentiometer Methods of Measuring Temperature, 206
- Whitehead (Dr.), the Village Deities of Southern India, 278
- Whitmill (C. T.), Reflection of Polarised Light, 103
- Whitmill (Mr.), Mutual Occultations and Eclipses of Jupiter's Satellites, 567
- Whittaker's Arithmetic of Electrical Engineering for Technical Students and Engineers, 365
- Wiedemann (Prof. E.), the First Known Mention of the Compass, 377
- Wien, das inneralpine Becken der Umgebung von, Dr. Franz X. Schaffer, 172
- Wilde Lecture of Manchester Literary and Philosophical Society, on the Physical Aspect of the Atomic Theory, Prof. J. Larmor, Sec. R.S., 450
- Wilkinson (S. B.), Geology of Islay, 184
- Wilks (W. A. R.), Influence of Light and of Copper on Fermentation, 191
- Wiley (Dr. A.), Pearl in "Window-pane Oyster," Ceylon, 326; *Rhynchobdella aculeata* in Ceylon, 345
- Williams (S. R.), the Symphyla, 39
- Willis (Mr.), Potomac River Basin, 68
- Willows (Dr. R. S.), the a Particles from Radio-active Substances, 439
- Wilsmore (N. T. M.), Keten, 47
- Wilson (A. A.), the Flora of West Lancashire, 194
- Wilson (Prof. Ernest), Electric Traction, 169
- Wilson (Prof. Gregg), Nest Eggs of Platypus, 149
- Wilson (Prof. H. A.), Gyroscopic illustrating Brennan's Mono-railway, 180
- Wilson (Prof. Harold A., F.R.S.), Radium and the Earth's Heat, 365
- Wilson (Prof. James), Mendelian Characters among Short-horns, 509, 559
- Wilson (John H.), Re-determinations of the Atomic Weight of Lead, 496
- Wilson (J. S.), Stresses in Masonry Dams, at Institution of Civil Engineers, 303

Wilson (R. E.), Measures of Double Stars, 281
 Wilson (Dr. W. E., F.R.S.), Death and Obituary Notice of, 443
 Wind-pressure, Experiments on, Dr. T. E. Stanton, 139
 Winding of Rivers in Plains, Sir Oliver Lodge, F.R.S., 7, 79; R. D. Oldham, 55; R. C. Slater, 79; J. Y. Buchanan, F.R.S., 100; J. Lomas, 102; Dr. John Aitken, F.R.S., 127
 Winds of Northern India, the, 353
 Winkelmann (Dr. A.), Handbuch der Physik, 559
 Wireless Telegraphy: Wireless Telegraphy Apparatus on board French Warships, 62; Magnetic Oscillators as Radiators in Wireless Telegraphy, Dr. J. A. Fleming, 71; the Use of Variable Mutual Inductances, A. Campbell, 71; New Transatlantic Wireless Station at Knockree, the Poulson System of Wireless Telegraphy by Undamped Waves, 88; Determination of the Time, both on Land and at Sea, with the Aid of Wireless Telegraphy, Bouquet de la Grye, 551; Jahrbuch der drahtlosen Telegraphie und Telephonie, Supp. to March 5, ix
 Wireless Telephony: Telephoning without Wires, Valdemar Poulsen, 587; Jahrbuch der drahtlosen Telegraphie und Telephonie, Supp. to March 5, ix; Wireless Telephony in Theory and Practice, E. Ruhmer, Supp. to March 5, ix
 Wires, Inductance in Parallel, Dr. J. W. Nicholson, 295
 Wirtz (Dr.), Ephemeris for Comet 1907e, 281
 Witherby (Mr.), Spread of the Little Owl in England, 564
 Wolf (Prof.), Further Observations of Comet 1907a, 158; Return of Encke's Comet (1908a), 234; Observation of Encke's Comet on December 25, 1907, 281; Photographic Observations of Encke's Comet, 302; Encke's Comet 1908a, 353
 Wolff (F. A.), Investigation on the Clark and Weston Standard Cells, 280
 Wologdine (S.), the Density of Graphite, 287
 Wood (J. M.), Flora of Natal, 565
 Wood (Prof. R. W.), How to tell the Birds from the Flowers: a Manual of Floriculture for Beginners, 7
 Woodlands, Heaths and Hedges, Our, W. S. Coleman, 554
 Workshop Practice, Engineering, Charles C. Allen, 28
 Worms and Tree-planting, E. A. Andrews, 205
 Worsdell (W. C.), Abnormal Structures in Leaves, 142
 Wray (L.), "Biak," Opium Substitute favoured by the Malays, 517
 Wrede (Franz), Manganese Chloride as Fixed Point in Thermometry, 207
 Wright (Prof. G. F.), Chronology of the Glacial Epoch in North America, 334
 Wright (Herbert), Rubber Cultivation in the British Empire, 99
 Wright (Dr. William), l'Europe préhistorique, Sophus Müller, 578
 Wright (W. B.), the Two Earth Movements of Colonsay, 454
 Wrightson (Sir Thomas, Bart.), on the Impulses of Compound Sound Waves and Mechanical Transmission through the Ear, 289
 Wye, Kent, the Journal of the South-Eastern Agricultural College, 345
 X-Radiators, Classification of Secondary, Dr. C. G. Barkla and C. A. Sadler, 343; Dr. B. Walter, 462
 Yamanouchi (S.), Sporogenesis in the Fern Genus *Nephrodium*, 418; Fertilisation in *Nephrodium molle*, 614
 Yerkes (Robert M.), the Dancing Mouse, a Study in Animal Behaviour, 533
 Yorkshire, the Birds of, T. H. Nelson, W. Eagle Clark, and F. Boyes, 511
 Young (A. P.), Stages of Soil Denudation and Forest Destruction in the Tyrol, 334
 Young (Prof. C. A.), Death of, 277; Obituary Notice of, 324
 Young (Ernest), a First Year's Course in Geometry and Physics, 482
 Young (M. S.), Development of Pollen Grain in *Dacrydium*, 114

Zacharias (Dr. Otto), das Süsserwasser-Plankton, 556
 Zambonini (Dr. F.), Strüverite and its Relation to Imenonurite, 358
 Zeeman (Prof. P.), Scientific Worthies, Sir William Crookes, 1; an Early Acoustical Analogue of Michelson's Echelon Grating, 247; Magnetic Resolutions of Spectral Lines and Magnetic Force, 615
 Zeller (Dr. Julius), Chemie der höheren Pilze, eine Monographie, 553
 Zengheli (Prof. C.), Ancient Dies for Coinage, 65
 Zencke (Dr. J.), Theory of a Receiver consisting of a Comparatively Short Vertical Wire, 327
 Ziegler Polar Expedition of 1903-5, Results obtained by the, J. A. Fleming, 207; Anthony Fiala, Dr. C. Chree, F.R.S., 544
 Zodiacal Stars, a Catalogue of, H. B. Hedrick, 353
 Zoology: the Fauna of Madagascar, Frank E. Beddard, F.R.S., 8; Zoology of Egypt, the Fishes of the Nile, G. A. Boulenger, F.R.S., 10; "False Scorpion," *Chelifer cancroides* in Great Britain, 15; Suggestion for Subdivision of Australasian Zoological Region, G. W. Kirkaldy, 16; National Antarctic Expedition, 1901-4, 33; die Fauna Südwest-Australiens, Ergebnisse der Hamburger südwest-australischen Forschungsreise, 1905, Prof. W. Michaelsen and Dr. R. Hartmeyer, 51; the Nervous System of Vertebrates, Prof. J. B. Johnston, Dr. W. Page May, 73; Grundzüge der Tierkunde für höhere Lehranstalten, Prof. Karl Smalian, 76; Young Stages of Freshwater American Crayfishes, Prof. E. A. Andrews, 87; Additions to the Zoological Society's Menagerie, 87; the Family and Genera of Bats, G. S. Miller, 91; Death and Obituary Notice of Dr. Carl Bovallius, 112; the Extinction of Animals by Man; W. L. Distant, 113; Zoological Society, 119, 189, 334, 430, 477, 526, 599; the Dorsal Sense-organs of Chitons, Dr. M. Nowikoff, 135; Nest Eggs of Platypus, Prof. Gregg Wilson, 149; Muscles of the Head in Birds and Reptiles, Prof. H. F. Edgeworth, 155; Structure of the Roof of the Mouth in Birds and Mammals, Dr. W. Sippel, 155; Luminiferous Echinoderms, 170; Ergebnisse und Fortschritte der Zoologie, 245; a Monographic Revision of the American Tortoises of the Family *Cinosternidae*, F. Siebenrock, 304; Distribution of the Pine-marten in England and Wales, H. E. Forrest, 325; Resemblances between the Sirenian and the Cetacean Tongue, J. F. Gudernatsch, 350; *L. kawaii*, New Chinese Freshwater Medusa, Dr. Asajiro Oka, 398; Relation between the Geographical Distribution and the Classification of the Onychophora, Prof. Sedgwick, 478; Evolution of the Elephant, R. S. Lull, 494; Effects of Pressure upon the Direction of Hair in Mammals, Dr. R. W. Kidd, 526; Experimental-Zoologie, Dr. Hans Przibram, 529
 Zweckmässigkeit, organische, Entwicklung und Vererbung von Standpunkte der Physiologie, Dr. Paul Jensen, 100

INDEX TO LITERARY SUPPLEMENT.

Archæology: the Tabernacle, its History and Structure, Rev. W. Shaw Caldecott, Supp. to March 5, x; Solomon's Temple, its History and Structure, Rev. W. Shaw Caldecott, Supp. to March 5, x
 Baker (Dr. H. F.), an Introduction to the Theory of Multiply-periodic Functions, Supp. to March 5, v
 Bose (Prof. J. C.), Comparative Electro-physiology, Supp. to March 5, iii
 Caldecott (Rev. W. Shaw), the Tabernacle, its History and Structure, Supp. to March 5, x; Solomon's Temple, its History and Structure, Supp. to March 5, x
 Concrete Construction, Principles of Reinforced, F. E. Turneure and E. R. Maurer, Supp. to March 5, vi
 Danneberg (Dr. F.), der naturwissenschaftliche Unterricht auf praktisch-heristischer Grundlage, Supp. to March 5, viii
 Dress, the Heritage of, being Notes on the History and Evolution of Clothes, W. M. Webb, Supp. to March 5, vii

- Education: der naturwissenschaftliche Unterricht auf praktisch-heuristischer Grundlage, Dr. F. Dannemann, Supp. to March 5, viii
- Electricity: Comparative Electro-physiology, Prof. J. C. Bose, Supp. to March 5, iii; Modern Views of Electricity, Sir Oliver Lodge, F.R.S., Supp. to March 5, viii
- Engineering: Principles of Reinforced Concrete Construction, F. E. Turneaure and E. R. Maurer, Supp. to March 5, vi
- Evolution: the Heritage of Dress, being Notes on the History and Evolution of Clothes, W. M. Webb, Supp. to March 5, vii
- Geography: Physiography, Prof. R. D. Salisbury, Supp. to March 5, v
- Lodge (Sir Oliver, F.R.S.), Modern Views of Electricity, Supp. to March 5, viii
- Mathematics: an Introduction to the Theory of Multipy-periodic Functions, Dr. H. F. Baker, Supp. to March 5, v
- Maurer (E. R.), Principles of Reinforced Concrete Construction, Supp. to March 5, vi
- Optics: die binokularen Instrumente, Moritz von Rohr, Supp. to March 5, iv
- Physiography, Prof. R. D. Salisbury, Supp. to March 5, v
- Physiology: Comparative Electro-physiology, Prof. J. C. Bose, Supp. to March 5, iii
- Reinforced Concrete Construction, Principles of, F. E. Turneaure and E. R. Maurer, Supp. to March 5, vi
- Rohr (Moritz von), die binokularen Instrumente, Supp. to March 5, iv
- Ruhmer (E.), Wireless Telephony in Theory and Practice, Supp. to March 5, ix
- Salisbury (Prof. R. D.), Physiography, Supp. to March 5, v
- Science: der naturwissenschaftliche Unterricht auf praktisch-heuristischer Grundlage, Dr. F. Dannemann, Supp. to March 5, viii
- Solomon's Temple: its History and Structure, Rev. W. Shaw Caldecott, Supp. to March 5, x
- Stereoscopy: die binokularen Instrumente, Moritz von Rohr, Supp. to March 5, iv
- Stimulus and Response, Physiological, Supp. to March 5, iii
- Tabernacle, the, its History and Structure, Rev. W. Shaw Caldecott, Supp. to March 5, x
- Telegraphy, Wireless, Jahrbuch der drahtlosen Telegraphie und Telephonie, Supp. to March 5, ix
- Telephony: Jahrbuch der drahtlosen Telegraphie und Telephonie, Supp. to March 5, ix; Wireless Telephony in Theory and Practice, E. Ruhmer, Supp. to March 5, ix
- Turneaure (F. E.), Principles of Reinforced Concrete Construction, Supp. to March 5, vi
- Webb (W. M.), the Heritage of Dress, being Notes on the History and Evolution of Clothes, Supp. to March 5, vii
- Wireless Telegraphy: Jahrbuch der drahtlosen Telegraphie und Telephonie, Supp. to March 5, ix
- Wireless Telephony: Jahrbuch der drahtlosen Telegraphie und Telephonie, Supp. to March 5, ix; Wireless Telephony in Theory and Practice, E. Ruhmer, Supp. to March 5, ix

NATURE

A WEEKLY ILLUSTRATED JOURNAL OF SCIENCE

"To the solid ground
Of Nature trusts the mind which builds for aye."—WORDSWORTH.

THURSDAY, NOVEMBER 7, 1907.

SCIENTIFIC WORTHIES.

XXXVI.—SIR WILLIAM CROOKES, F.R.S.

SIR WILLIAM CROOKES has the rare privilege of looking back upon a scientific activity extending already over more than fifty-five years. By numerous papers and by several volumes the results of his experimental researches in different departments of physics and chemistry have been spread all over the world. Though born in 1832, even his advanced age has not diminished his scientific productiveness.

All Sir William Crookes's researches, with the exception of the first, were made in his private laboratory in Kensington Park Gardens. Although the motion of the walls of this laboratory, as seen under the high magnifying power of the horizontal pendulum, gave rise, at first sight, to doubts as to the solidity of its construction (*Philosophical Transactions*, 1876, Crookes, "On Repulsion, &c.," § 134), it has stood the test of time. The perennial stability, however, of many of the stones joined by Crookes to the edifice of science never was questionable. Most of those who have risen to eminence in physics have done so by giving their exclusive attention to that science, and it is only rarely that the physicist can do pioneer work also in chemistry. Rarer still is the case of Sir William Crookes, whose series of physical papers is frequently interrupted by communications concerning his chemical discoveries.

In the *Philosophical Magazine* of April, 1861, Crookes tells us:

"In the year 1850, Prof. Hofmann placed at my disposal upwards of 10 lb. of the seleniferous deposit from the sulphuric acid manufactory at Tilkerode, in the Hartz Mountains, for the purpose of extracting from it the selenium, which was afterwards employed in an investigation of the selenocyanides."

In the examination, by the spectroscope, of the residue left in the purification of the crude selenium, Crookes's

attention was attracted by a bright green line, which he had never met with before. In following up its appearance, he succeeded in isolating a new metal, which he called thallium, after the emerald green line which has become now as familiar to chemists, even if not brought up in a spectroscopic atmosphere, as the lines of sodium and lithium; and the physicist again and again enjoys the homogeneity of thallium light when observing interference for large differences of path, either with his Rowland or his Michelson grating, or with his Fabry and Perot apparatus, or with his Lummer and Gehrcke plate.

The year 1861 brought the first great triumph to Crookes. During the next twelve years he carried out minute investigations of the many properties of the new element, culminating in his determination of its atomic weight—203.642, or when reduced with the now accepted values for the atomic weights of oxygen and nitrogen, 204.04. Extreme care was given to the necessary weighings, and the pains taken to start with pure substances were enormous. The international committee for the atomic weights and other authorities regard Crookes's determination of the atomic weight of thallium as the best we possess, though thirty-four years have elapsed since the date of its publication.

Crookes finished his determination not without tribulation, having been troubled with discouraging irregularities in his weighings. In order to improve his results, the weighings were made in a partial vacuum, but even under these conditions the balance behaved most capriciously. Sometimes the substance appeared to be heavier when cold than when in a heated condition; sometimes the action was opposite. Working further with indefatigable ardour he came to what he then called "repulsion resulting from radiation," and going on he invented in 1875 an apparatus in illustration of the thoroughly novel and striking phenomena he had observed, the radiometer. His researches in this new field, contained in 485 paragraphs, and published in the *Philosophical Transactions* of 1874, 1875, 1876, 1878, 1879, represent an immense amount

of experimental work of the greatest interest and ingenuity.

Under the influence of the dynamical theory of gases the general nature of the perplexing phenomena was recognised and referred to the intervention of the residual gas. The genius of Schuster, Osborne Reynolds, Tait, Dewar, and Maxwell was associated with this explanation, but special mention should here be made of the more personal, yet beautiful and ennobling example of scientific cooperation given by Sir William Crookes and Sir George Stokes, the documents relating to which have just been published. The new and fascinating chapter in the dynamical theory of gases, relating to the stresses in rarefied gases arising from inequalities in temperature, which thus sprang up in connection with Crookes's experimental work, is, notwithstanding the 110 references to the literature of the radiometer in a modern German text-book, still unfinished. We may be sure that quantitative experiments concerning the radiometer actions under entirely new conditions will again prove the importance of the chapter, emblazoned on its cover by Crookes's light-mill.

Crookes thus was brought into touch with the dynamical theory of gases and with experimental work in high vacua, and so came to his experiments concerning the electric discharge in gases. In this province we are indebted to him for some very striking discoveries relating to the now well-known cathode rays, then already associated with the names of Plücker (1859), Hittorf (1869), and Goldstein (1876). His brilliant experiments ("The Trajectory of Molecules," "Molecular Physics in High Vacua," "Phosphorogenic Properties of Molecular Discharge") were published in the Philosophical Transactions for 1879, but became generally known to the world—not to the scientific world alone—by his lecture on "Radiant Matter," delivered on Friday, August 22, 1879, at Sheffield, to the British Association for the Advancement of Science. Even now the reading of this lecture, though the facts in it have become familiar, brings one under its irresistible charm, and Lenard and Tesla, describing in eloquent terms the impression made by it on their young minds, certainly give utterance to a prevalent opinion. In the beautiful volumes on "Ions, Electrons, Corpuscles," for which physicists are indebted to the Société française de Physique, only one lecture has been inserted, that of Sir William.

There exists perhaps only one lecture given on a similar occasion which has become as popular and made on the hearers as deep an impression, both by its contents and its accomplished form; I mean the lecture delivered before the Association of German Naturalists at Stuttgart in 1889 by Hertz, in which his great discoveries were expounded.

All the wonderful and important properties of the constituents of the cathode rays or of radiant matter: its darting in a straight line from the negative pole, the position of the positive electrode being unimportant; its casting of a shadow when intercepted by

solid matter; the strong mechanical action radiant matter seems to exert where it strikes; the change of direction by a neighbouring magnet; the heat produced when its motion is arrested; the remarkable power which the molecular rays possess of causing phosphorescence in preparations of calcium sulphide shining with blue-violet, yellow, orange or green light, in diamonds shining with nearly all colours of the rainbow, in rubies glowing with a rich full red; all these results Crookes tried to explain by the hypothesis that the cathode rays, or streams of radiant matter, or of matter in an ultra-gaseous state are particles or molecules negatively charged and projected with great velocity from the negative electrode. The inherent truth of Sir William Crookes's hypothesis concerning the nature of the cathode rays is, after much controversy for a space of nearly twenty years, now established, and the original hypothesis, with finer contents, is now accepted by all physicists.

In Crookes's experiments for the first time the majestic simplicity of the cathode rays became clearly apparent. In the irritating complexity of the other phenomena of the vacuum tube, appearances of great purity had been isolated, so that Crookes could risk the opinion "that we are here brought face to face with Matter in a Fourth state or condition," neither solid, liquid, nor gaseous.

Crookes alone among his contemporaries recognised the essential importance of the cathode rays, and with almost prophetic insight foresaw the part radiant matter would have to play in the development of physical science. In the splendid evolution of electronic theory we are now witnessing, we see how true Crookes's foreshadowing of the rôle of radiant matter was.

"In studying this Fourth state of Matter, we seem at length to have within our grasp and obedient to our control the little indivisible particles which, with good warrant, are supposed to constitute the physical basis of the universe. We have seen that in some of its properties Radiant Matter is as material as this table, whilst in other properties it almost assumes the character of Radiant Energy. We have actually touched the border land where Matter and Force seem to merge into one another, the shadowy realm between Known and Unknown, which for me has always had peculiar temptations. I venture to think that the greatest scientific problems of the future will find their solution in this Border Land, and even beyond; here, it seems to me, lie Ultimate realities, subtle, far-reaching, wonderful.

"Yet all these were, when no Man did them know,

Yet have from wisest Ages hidden been;

And later Times things more unknowne shall show.

Why then should wittesse Man so much misweene,

That nothing is, but that which he hath seene?"

All the experiments in this lecture now have become classical, and several of them are repeated every year in every university of the world. The most familiar and representative of the group is perhaps that one with the Maltese cross in the pear-shaped Crookes's tube, in which the black shadow of the cross is projected on the hemispherical phosphorescent end

of the tube, in such a manner that a permanent impression on the memory of the student is made.

As an outcome of work recorded in Crookes's various preceding papers, "On Repulsion resulting from Radiation," &c., and, therefore, with paragraphs numbered in continuation of his "Phosphorogenic Properties of Molecular Discharge," Crookes in 1881 published a research on "The Viscosity of Gases at High Exhaustion." Maxwell's great theoretical discovery that the viscosity of a gas is independent of the density, one of the most beautiful proofs for the reality of molecular motion, had already been the starting-point of experiments by Maxwell himself, Kundt and Warburg, using the method of rotating discs.

In Crookes's experiments the method of observation consisted in noticing the subsidence of the vibrations of a delicately suspended lamina oscillating within a bulb containing the gas. By these simple yet adequate means, very careful measurements were made, and the falling off of the viscosity of different gases from atmospheric pressure to very high exhaustions downwards observed, especial attention being paid to the highest vacua and definite measurements made of the degree of exhaustion employed. At these high exhaustions Maxwell's law completely breaks down, as Maxwell himself foresaw. His observations were discussed in a splendid "note" by Sir George Stokes, another example of the cooperation between these physicists.

Crookes's apparatus afforded at the same time many other data and measurements. The apparent attraction by heat was only found in air of greater than one-thousandth part of ordinary density; while there is repulsion when the density is further increased, the repulsion increasing to a maximum, and thence fading away towards zero as the rarefaction is continued.

In 1881 Crookes's paper on radiant matter spectroscopy appeared. An entirely new method of spectrum analysis is given, based on the well-known fact that under the influence of the cathode rays a large number of substances emit phosphorescent light, some faintly and others with great intensity. Most bodies give a faint continuous spectrum, but more rarely the spectrum of the phosphorescent light is discontinuous, and to bodies manifesting it his attention has been specially directed. This characteristic spectrum is given by the group of elements known as the rare earths, especially yttria in some of its compounds; and in the study of this group the method is of very great importance, and has given, in the hands of Sir William Crookes, at an immense amount of trouble and time, very valuable results. To give, however, an adequate survey of these investigations would demand much space, and uncommon chemical knowledge of the rare earths. We mention only that not long ago Crookes isolated from yttria a new earth, characterised by an isolated strong group of lines high up in the ultra-violet, ascribed by Sir William to a new element named by him victorium.

In connection with his work on the photographed spectra of the elements, of which it seems only a small portion has been published, we record one of his smaller papers, relating to "the slit of a spectro-scope," that narrow, but extremely important, gate to a large domain. Crookes makes the very ingenious suggestion to use quartz jaws, cut in the same manner as metal ones. The prismatic edges refracting away all the light which falls on them, their transparency offers no objection, while only the light passing between the jaws comes into operation. As the quartz jaws can be worked to a finer edge, they give better definition.

"With a pair of jaws in the spectroscope at present in use, I can take excellent photographs when they are only 0.0001 inch apart. For eye observation the width can easily be less than that."

Another small paper of date 1879 is also characteristic of Crookes's experimental skill, and illustrates at the same time, if I may say so, the purity of his work. The exceedingly small rate of leak of electricity in a high vacuum is illustrated by Crookes's observation that a pair of gold leaves in a vacuum bulb retains an electrical charge for months.

Of Crookes's recent work, we mention his experimental work on radium. In 1900 Crookes first effected the separation from uranium by two distinct chemical methods of the one direct transformation product, called uranium X. He discovered in 1903 that the alpha rays from radium produce, probably by their bombardment, phosphorescence on a target of crystalline zinc sulphide. This wonderful phenomenon, perhaps the most direct proof of the discontinuous structure of matter, was popularised in his spintharoscope.

These examples must suffice to impart an idea of Crookes's work. "The best history," it has been verily said, "is but like the art of Rembrandt; it casts a vivid light on certain selected causes, on those which were best and greatest; it leaves all the rest in shadow and unseen." What is true in the science of history cannot become untrue in the history of science. It would be desirable to follow a similar precept in trying to picture before our mind the origin of the gratitude and admiration physicists feel for a philosopher, who by his experimental skill, his acute observation, and the continuity of his endeavours, combined with his daring intuition, has impressed indelible marks in different branches of physics and chemistry. This involves, however, more than we can attempt here.

Sir William Crookes is a member or corresponding member of a number of scientific societies in his own country and abroad. At one time or another he has occupied the presidential chair of many of the leading learned and scientific societies of Great Britain. The Royal Society awarded him a Royal Medal in 1875, the Davy Medal in 1888, the Copley Medal in 1904; the French Académie des Sciences, a gold medal and a prize in 1880; the Society of Arts, the Albert Medal in 1890; and he was knighted by the late Queen Victoria in 1897.

P. ZEEMAN.

THE SOILS OF IRELAND.

A Description of the Soil-Geology of Ireland, based upon Geological Survey Maps and Records, with Notes on Climate. By J. R. Kilroe. Department of Agriculture and Technical Instruction for Ireland. Pp. xii+300. (Dublin: H.M. Stationery Office, 1907.) Price 6s.

IN his preface the author states that on the completion of the one-inch geological map of Ireland "the opportunity seemed favourable for presenting to the public a succinct account of the geology of the country, prepared chiefly from the standpoint of agriculture," of which opinion the present work is the outcome.

It is certainly a matter of cardinal importance to an agricultural country like Ireland that its Geological Survey officers should have the needs of the farmers before them, and should in the progress of their mapping look at the country-side with something of the farmer's eye, and an appreciation of the kind of information that is likely to be of value to him.

It is perhaps too much as yet to ask that the Geological Survey should give rise to a second department charged with the preparation of soil maps, though in other countries the State is undertaking this service for the agriculturist; but, failing so large a measure, what information of value to the working farmer can the geologist proper put into his maps and memoirs? A good "drift" map must be the basis, a map in which, however, the drift should be differentiated further than it is on our present maps, where the common designation of "boulder clay" is often made to cover in a single district true clays, coarse stony gravels, and deposits that are little more than sand. Of course, the boundaries of such drifts can only be indicated approximately, partly because they grade into one another in some places, and in others thin out insensibly into true "sedentary" soils derived from the underlying "solid" rock. To the farmer, lithological character is the important feature in a drift, not its origin, and we believe the field geologist would find no difficulty in providing the information if he had the requirement before him from the outset. Again, some indication of the thickness of the drift might be given, with notes as to the proximity of valuable soil ameliorators, like beds of marl below peat or chalk below clay. Of course, much chemical analysis cannot be recorded, but we think the map should indicate whether a clay formation is calcareous or deficient in lime; again, some notes on drainage and water supply might be added to the memoir. A farmer, for example, finds a certain field full of springs; a geologist could generally tell him whether this is due to the outcrop of an impermeable band or to a fault (in which case a ditch can be cut to tap the springs), or to general ground water, in which case the field will want tile draining.

Mr. Kilroe, however, has no opportunity in this book of working on such a scale; his object has rather been to do for Ireland what the late Prof. E. Risler did for France in his "Geologie Agricole,"

to take the formations one by one and show how the nature of the rock is reflected in the physiography and the soil constitution, and in its turn in the agriculture of the district it occupies. To produce such a book is a noble ambition, but we fear that the materials for it hardly exist as yet in the case of Ireland, for throughout Mr. Kilroe's book we are struck by the paucity of data really bearing on the point at issue. The analyses of rocks and soils, even of waters, are rarely of Irish origin; often, indeed, they refer to Continental specimens, and they are of very various dates and values. There is hardly a reference to Irish farming in the book; for instance, barley growing is a very special and localised culture in Ireland, and one which has had considerable attention from the Department of Agriculture, but when we inquire if it is associated with any formation in particular, we find no reference to it, nor, indeed, to the distribution of any other crop, in Mr. Kilroe's book. Instead, Mr. Kilroe gives us too much of his views on agricultural chemistry, generally in the form of extracts from other writers, and these extracts only show how difficult it is for a specialist to preserve a due critical sense when "getting up" another subject. For example, we read:—

"When it is considered that silicate of alumina (clay) in itself furnishes no essential element of plant food . . . it is evident that the stony particles, pebbles, &c., contain the stock supplies of mineral nutrients."

Or again:—

"The waters flowing from the Old Red Sandstone would doubtless be poor in lime for the purpose of irrigation. They, however, probably contain such a proportion of potash as would justify some expense in distributing them over meadow-land or pasturage not being grazed."

We only wish that Mr. Kilroe could have tempered his zeal for imparting information. It is just the same with the section on climate; we have a series of paragraphs on soil and air temperatures, on cyclones and weather forecasts, on clouds and similar generalities, but little or nothing on the Irish climate or its local distribution, which counts for so much in the agriculture of the country.

"Cut the cackle and come to the 'osses" was an old and sound piece of advice, and the "osses" we hope to get from Mr. Kilroe are Irish—Irish rocks, Irish soils, Irish crops and stock. A. D. H.

SCHOLARSHIPS AND INDUSTRY.

Dyeing in Germany and America. By Sidney H. Higgins. Pp. xvi+112 (Manchester: University Press, 1907.) Price 1s. net.

THE Gartside scholarships of commerce and industry were established in 1902 for a period of ten years. They are of a special character, the main feature of the scheme under which they are administered being the close manner in which they are linked up with industrial life. The first year of the scholarship is tenable in the University of Manchester, a course of study being adopted which will directly qualify the scholar to investigate some special branch

of commerce or industry at home and abroad during the second year. The scheme is a most valuable recognition of the close union which should exist between science and industry, and the late Mr. Gartside has certainly indicated a very useful direction in which others may endow further scholarships. The book now under review represents a report to the electors of the work carried out during the period of the scholarship.

A comparison of the development of the coal-tar colour industry in Germany and this country has been so frequently made to the great disparagement of English enterprise and educational methods, that very properly this branch of the subject was not further investigated by the author, his work being concerned with the application rather than the manufacture of dyes. The fact that in the main we hold our own against all competitors in the dyeing and printing industry is brought out very clearly. In Germany the dye-houses are, with few exceptions, smaller, and the methods less scientific, than in the large centres of the industry in England, such as Manchester and Bradford; and in handicraft skill the English dyer is perhaps unapproachable. The great volume of dyeing done in the United States appears to be chiefly due to the large and rapidly increasing demand made by the home market, and the competition of America in foreign markets is comparatively insignificant in this branch of trade. Moreover, in most of the principal dye-houses in New England the managers and foremen are British. The distribution of trade is, however, a matter of very delicate balance, and the fact that Germany has almost the monopoly of the manufacture of coal-tar dyes may easily result in the transfer to her of the leading position in the dyeing industry.

The coal-tar colour industry is, in fact, one of Germany's greatest industrial assets, and apart from its directly profitable character it has also been of the greatest importance as the mother of many new industries, such as those of synthetic pharmaceutical products, liquid chlorine, anhydrosulphuric acid, &c. The requirements of the industry have also reacted largely on the standard and character of the instruction given in the German universities and colleges, and, most important of all, have been a great object-lesson to the German Government and people with regard to the supreme importance of science in industrial life. This has again reacted in the direction of the more general appreciation and utilisation of technical education in Germany, and has been an important factor in inducing the Government and local authorities to render assistance in fostering the various industries; a condition of things which, unfortunately, is largely absent in this country.

A great feature of the dyeing trade in England has been the establishment of powerful trade combinations, whereas the industry has not developed along these lines in Germany or in America. It is undoubtedly true that when efficiently managed these large associations lead to great economies in such directions as the concentration of work, improvement of equipment, and better conditions for buying and selling. Operations conducted on a large scale can

be carried on more cheaply and more profitably than is possible by a large number of smaller producers. Consequently, both workman, employer, and consumer should benefit. On the other hand, the danger of the misuse of great concentration of power is well known, and experience has yet to show whether the condition of an industry controlled in this manner is as stable and permanent as when competition and individual enterprise have freer scope.

Turning to a more definite criticism of the work under review, it undoubtedly forms very interesting reading if not examined too closely as regards technical accuracy. The material is arranged under the following headings:—cop dyeing, sulphur colours and indigo, mercerising, bleaching, the industry in the United States, conditions of life in the industry, efficiency of the industry, colour production. It could not reasonably be expected that the author would be able to show a profound knowledge of present-day practice in all branches, and it would not be fair to criticise the book from this standpoint. It must rather be considered as the statement of an organised series of observations made by a trained mind upon a subject of which the observer has some special knowledge. If read with this in view, the book will be found most interesting and valuable. The author has made excellent use of the great facilities placed at his disposal, and has done much to justify the idea of the founder of these scholarships that they would be of value, not only to the individual, but to the trade of the country. In conclusion it must be said that the literary style and even the grammar and punctuation of the subject-matter are open to much more criticism than is desirable in a book issued with the imprint of a university. The idea that a careless use of the English language is permissible in books dealing with technical subjects is one to which too strong exception cannot be taken.

WALTER M. GARDNER.

PERSONAL HYGIENE.

The Care of the Body. By Dr. Francis Cavanagh. (The New Library of Medicine, edited by Dr. C. W. Saleeby.) Pp. xvi+292. (London: Methuen and Co., n.d.) Price 7s. 6d. net.

THIS book belongs to the excellent "New Library of Medicine" series issued by Messrs. Methuen. In the series, as planned, all the great aspects of "preventive medicine" are dealt with from many standpoints. In "The Care of the Body" Dr. Cavanagh handles in a very popular yet fundamentally scientific way the leading generalities of personal bodily hygiene—sleep, baths, exercise, training, fatigue and massage, clothing, skin, hair, teeth, feet and hands, light, eye, ear, nose. Each of these has a chapter. The volume is completed by chapters on position, habit, and the functions of the physician. The style is breezy and rapid. It is well adapted to the lay reader, who more easily acquires casual than rigidly ordered knowledge. But Dr. Cavanagh indicates in every page an easy familiarity with the latest science at the moment when apparently he is most exuberant in his verbal flow.

The method has its dangers, for it may give currency to vague and inexact doctrines. But here the sparkle of the writing secures the interest without impairing the science. Health is undefined, but the problem of health is mainly how to maintain the fight against malign environment, and "fitness" is largely the capacity to master hostile germs. The discussion of sleep adapts scientific theory to practice, and has many sound hints. Of the cold bath it is said, "In general, the value of a cold bath is in inverse proportion to its length" (p. 39). Of exercise, the view is that "all mental processes are based upon a simple unit of action or process, in which some one muscle-fibre is a chief factor" (p. 55). Play is preferred.

The criticism of current superstitions as to exercise and training is pointed and conclusive. The cardinal point is the relation of exercise to diet. Dr. Cavanagh is somewhat dogmatic (p. 60) on the intellectual training of women. He assumes too readily that accepted intellectual standards are a true test of mental capacity even in men. In exercise, walking and running, not any artificial system, are fundamental. "Muscles are not meant to work or be developed individually" (p. 78).

The discussion of fatigue is highly general, but adequate for its purpose. Of clothing a good deal is said in detail, the principle being that "man is homoiothermal," and $98^{\circ}.4$ Fahrenheit is his normal temperature. Clothing is closely criticised from this standpoint. In the other chapters—teeth, eyes, &c.—many hints of experience are embodied, and, though the main facts are well known, every reader will find them set forth in a fresh and stimulating way. The chapters on position and habit are well loaded with good matter. The last chapter points the view that dominates this book and the series it belongs to, namely, that henceforward the physician's true function is to prevent, not to cure, and the profession should be organised accordingly. Altogether, the author succeeds in his effort to be simple, scientific, and vivacious. The aim of the series is to apply scientific medicine to the informing of public opinion, and this volume, within its range, certainly furthers that aim. If looked-for topics are sometimes omitted, they are likely to be found in other volumes.

OUR BOOK SHELF.

Practical Mathematics. By Prof. John Perry, F.R.S. Pp. 183. (London: Wyman and Sons, Ltd., 1907.) Price 9d.

The first edition, a slim little pamphlet price sixpence, was reviewed in these columns about the end of the last century; this new edition begins to show signs of corpulence.

The pamphlet has raised a crowd of imitators, bulky works on engineering and mathematics, workshop arithmetic, and general utilitarian and commercial theory; it would be better, for historical interest, to preserve its original size.

The author has forced the Mathematical Tripos to adopt the Slide Rule for numerical computation; and would do well to follow up by a description of the Hospitalier notation of writing derived units, as ft.² and ft.³ for square and cubic feet, lb./ft.² for pressure,

and so on; no need then for the mathematical Esperanto suggested some years ago.

The slide-rule hint—"practise with simple numbers"; "ask no one to help you"—should be followed by arithmetical exercises intended to show the learner how to discover the use for himself: such as cube 2, 3, 4, . . . and then extract the cube root; better then to discard all rules, as they can always be re-invented with greater ease than recollected. Considering that the slide rule and logarithm table work to the base 10, the definition of the logarithm in § 8 is $-n = \log N$, if $10^n = N$; not $a^n = N$, which is confusing by its useless generality.

The practical student Prof. Perry has in view is called upon to work and act, but not to write and explain. His geometry is so very easy, consisting in drawing a few lines by instruments. But if required to give an explanation he would find himself compelled to give six lines or more of tedious definition to one line of demonstration; he would become Euclidean without knowing it.

The author enjoys attacking the schoolmaster, who shows certainly many weak points of inherited prejudice. Prof. Perry looks at geometry from the point of view of everyone becoming an engineer in his turn; the schoolmaster deals with very few students of that class, and can make out a very good case for Euclid; Greek in Euclid and Euclid in Greek; and he has an answer ready for the question in the note on p. 8—"Why not say—*delogarize*?"—Because the word is a mongrel.

La Théorie de la Physique chez les Physiciens contemporains. By Abel Rey. Pp. vi+412. (Paris: Félix Alcan, 1907.) Price 7.50 francs.

RECOGNISING the serious discordance between the views of contemporary physicists upon the true meaning and value of physical theories, the author of this interesting book inquires whether this conflict of opinion justifies the contention of the anti-intellectualist philosophers that such theories are purely arbitrary constructions leading, not to completer knowledge of the world, but merely to more effective practical control of its course. M. Rey proceeds by an able cross-examination of actual scientific thinkers, classifying them by reference to their attitude towards the post-Newtonian mathematical physics—which assumed the actuality in detail of the molecular machinery that it invoked to explain phenomena.

In his first group fall Rankine, Mach, Ostwald, and Duhem, who agree in rejecting the ontological pretensions of the mechanical theory and in conceiving the various departments of physics as autonomous sciences connected with one another and with mechanics by the notion of energy. British readers will be gratified by the importance which the author attaches here to the work of our countryman—whom he regards as the father of the critical movement—and will welcome his clear account of the views of the brilliant professor of Bordeaux. Next to these M. Rey places Poincaré as a critic who corrects rather than rejects the traditional doctrine, accepting its belief that the data of observation in physics are the product of the superposition of an infinite number of elementary phenomena to which the differential equations of theory refer, but recognising that its conception of these phenomena as molecules in movement is only a description in one idiom of objective relations that could equally well be rendered in another. Last come the physicists (including most of the British school) who have lost the confidence of the post-Newtonian mechanists rather than their ideals; who still hold that physical phenomena can be explained by the conceptions of

mechanics, but no longer profess to be able to describe, detail by detail, the ultimate moving elements and motions that underlie these phenomena.

In the second part of his book the author seeks to show that the salient divergences between the schools simply mask the essential congruity of their views. All physicists admit—in whatever idiom they may describe them—the same ultimate objective data; while even if their hypotheses are only methodological instruments of organisation and discovery, it must be recognised that the science presents in the different schools a real though not obvious unity of development. T. P. N.

How to tell the Birds from the Flowers: a Manual of Florithology for Beginners. Verses and illustrations. By Prof. R. W. Wood. Pp. 28. (San Francisco and New York: Paul Elder and Company, n.d.) Price 50 cents net, or in cat-bird cambric, 75 cents net.

It will come somewhat as a surprise to those of our readers who know Prof. Wood only as a physicist to learn that the present booklet contains nothing but quaint illustrations and jest in verse. The volume is obviously a satire directed against the sentimental nature-study literature which sometimes masquerades as scientific teaching, particularly in the United States.

LETTERS TO THE EDITOR.

[The Editor does not hold himself responsible for opinions expressed by his correspondents. Neither can he undertake to return, or to correspond with the writers of, rejected manuscripts intended for this or any other part of NATURE. No notice is taken of anonymous communications.]

Winding of Rivers in Plains.

A CURIOUS obsession as to a matter of fact, to which everyone is more or less liable when obfuscated by an erroneous theory, has recently been noticed by me in some geological books, e.g. in Le Conte's "A Compend of Geology," and in Tyndall's "Glaciers of the Alps." I noticed it first in my late colleague Prof. Watts's recent little text-book of geology; but, indeed, I have not found any book of the kind quite clear and correct on the subject.

The statement is clearly made and illustrated by a figure that the flow of a bending river is most rapid on the outer side, where its banks are concave; and the well-known scouring or excavating action which a stream exerts on this bank is then attributed to this imaginary more rapid flow.

But the fact is that the flow is most rapid on the inner or sediment-depositing side of the bend, and Prof. James Thomson showed in 1876, in a well-known communication to the Glasgow meeting of the British Association—when he exhibited a model, confirming calculations previously made by himself—that the excavating action of a river is not due to the direct scouring action of the main stream at all. The explanation which he gave was virtually as follows:—

The rapid flow on the inner and strongly curved side of the bend piles up the water on the outer side by centrifugal force, so that near the concave bank it is nearly stationary, but elevated; its energy there is potential, not kinetic. Now if the rapidity of flow were uniform from top to bottom the slope would be in equilibrium; but owing to the retardation of the bed the flow near the bottom is slower, and there is not nearly so much centrifugal force exerted down below; wherefore the piled-up water is continuously returning from upper to lower level, that is, from the concave to the convex bank, as an undercurrent, almost at right angles to the main stream, bringing with it, by its undertow, silt and solid matter, which it deposits near the inner side of the bend; thus constantly increasing its own sinuosity in the well-known way.

The stream itself, combining a progressive with a lateral

circulating motion, may be said to screw itself like a corkscrew round a bend: and it is the lateral circulation which shifts the bed.

So much for streams, now for glaciers. Prof. Tyndall, as is well known, took careful measurements of the flow of glaciers, and finding that their line of quickest motion was more sinuous than the glacier bed, said that this was another analogy to the flow of a river.

There, however, he was in error. The line of most rapid flow of a river is less sinuous than the river itself. The water flows round the bend somewhat as it would flow in a vertical columnar vortex; most rapid on the inside, and almost stationary or even retrograding on the outside of some bends. If ice flows otherwise—and I have no reason whatever to doubt Tyndall's measurements—it must be because the rate of change of momentum of so slow a motion, compared with its lateral stiffness, is very small; so that we might certainly anticipate that the laws of its flow would be in many respects different from—though also in some respects singularly like—those of a liquid of but small viscosity. Probably it obeys exactly the laws of an extremely viscous liquid the viscosity of which could be specified. The flow cannot be much governed by inertia, as that of water is.

But I know that glacier motion is a thorny subject upon which I have no desire to tread. I would not be understood as making any assertion concerning it, but merely throw out a hint.

As to winding rivers, however, the matter is fairly simple; and the writers of geological and geographical text-books may easily amend some incautious though natural statements as to matters of fact, which they sometimes illustrate by erroneous diagrams.

OLIVER LODGE.

Recalculation of Atomic Weights.

DURING the last few years our knowledge of the accurate atomic weights of the elements silver, sodium, potassium, chlorine, and bromine has been greatly extended by the masterly researches of T. W. Richards and his colleagues. At present, however, there is no really trustworthy value for the ratio of silver to oxygen, and a satisfactory value for nitrogen has only just been obtained by Gray and by Guye.

While reading an account of the determination of the ratio Ag:AgNO₃, it occurred to me that this result, together with others previously obtained by Richards, afforded a means of calculating absolutely the atomic weights of the above-mentioned elements in terms of oxygen. The following values are available:—

			Error
(1)	Ag:KCl=100:69.1073	0.0004=ν
(2)	AgCl:KCl=100:52.0118	0.0004=x
(3)	Ag:AgNO ₃ =100:157.479	0.001=ω
(4)	Ag:AgCl=100:32.867	0.0005=γ
(5)	N ₂ O ₅ :K ₂ O=100:87.232	0.002=ε

We have thus five simultaneous equations, from four of which the four unknown quantities Ag, K, Cl, and N can be calculated in terms of O. Neglecting 2, and putting O=16, I worked out the atomic weight of N, and was intensely surprised to find the value 13.940.

Now it is a well-known fact that the final results of an "indirect analysis" such as the above may be greatly influenced by a small experimental error, and so I proceeded to estimate the maximum effect which could thus be produced. Putting (69.1073+ν)Ag=100KCl, where ν is the error, instead of the first equation above, and similar expressions for the last three, I obtained the formula

$$N = \frac{2422.08 + 600\epsilon - 600\gamma - 336\omega - 287\epsilon}{2779.94 - 200\nu + 200\gamma + 174\omega + 115\epsilon} \times 16.$$

From this it is evident that, if ν is made positive and the other three quantities negative, the numerator will be increased and the denominator diminished, both these facts tending to raise the value of N. Putting for the symbols their values given in the table of errors, the following result is obtained:—

$$N = \frac{2422.08 + 1.15}{2779.94 - 0.58} \times 16 = 13.951.$$

In a precisely similar way, but using equation 2 instead of 1, the value 13.037 is obtained, which can be increased to 13.948.

This being the case, the question is, How can this value arise? The experimental work upon which the figures are based seems to have been carried out with every possible precaution, and all the values agreed very closely. The only possible weakness appears to lie in equation 5; the result was deduced from only three experiments, and the agreement was not so good as usual. Assuming for the moment that this value is wrong, it is easy to calculate by how much it is so. Taking $N=14.010$, we may say

$$N = 14.010 = \frac{2422.08 + 6.62}{2779.94 - 3.57} \times 16.$$

If the values of x , w , and y are taken as before, this gives 0.028 as the minimum value of z , and it is hardly to be expected that such a large error could have escaped notice. Another possibility is that all the errors are about five times as large as the values given, but even if this were so it would be very improbable that they should all be of such a nature as to raise the atomic weight. Consequently, granted that the discrepancy is due to experimental error, it is almost certain that the analysis of potassium nitrate is at fault. This was carried out by heating with silica, and if the nitrate was not completely decomposed the number 87.232 would be too great. This is the only explanation which seems reasonable; and, moreover, if the ratio obtained in this experiment be changed to 100:87.203, all five equations become consistent, and yield frequently accepted values for the atomic weights, silver being 107.883.

Whether this be the true explanation or not, it is obvious that the method outlined above affords an excellent means of checking atomic weight determinations, and is also applicable to finding the absolute weights, since there is no great accumulation of errors.

H. E. WATSON.

University College, Gower Street, October 26.

The Fauna of Madagascar.

MADAGASCAR, with certain adjacent islands, has been regarded by some naturalists as forming a distinct "region," the Malagasy, equivalent to the other main regions of the world. On the other hand, Messrs. P. L. and W. L. Sclater ("The Geography of Mammals," London, 1899, p. 108) adhere to the earlier opinion of the first-named of the two authors, as well as of many subsequent writers, and place Madagascar in a subregion only of the Ethiopian region. They remark that "Madagascar appears to contain a sample of the ancient Ethiopian fauna, which has been almost exterminated on the mainland."

The archaic nature of the Madagascar fauna has lately (*Zool. Jahrb.*, 1902) received further confirmation at the hands of Miss A. Carlsson, who found that the peculiar Viverrid genus *Eupleres* showed likenesses to both the Viverrine and Herpestine sections of the Viverridae, and was therefore probably an ancient type of Viverrid. Having had lately the opportunity of making some anatomical observations upon another Madagascar genus, viz. *Galidictis*, I am able still further to support this view. This interesting Viverrid has the external scent glands of the Viverrine section, and a *crecum* which is comparatively long, like that of the Herpestine. The brain, like that of *Eupleres*, shows intermediate characters. Finally, the archaic nature of this animal is demonstrated by the completely double uterus, a feature new to the Carnivora, where a bicornuate uterus is at least the rule.

It has been pointed out that Madagascar also shows an unexpected likeness to the neotropical region in its fauna, especially in the group of reptiles. As to mammals, the late Dr. Dobson showed reasons for believing that the alleged close resemblance between the Cuban *Solenodon* and the Mascarene *Centesetes* had been exaggerated; but among the Reptilia there are genera which are common to the two regions, e.g. the snakes *Boa* and *Corallus*. I have been able lately to compare *Corallus madagascariensis* with a South American form, *C. cookii*. In the former the bronchus extends a long

way down the larger lung, the liver is prolonged by one lobe nearly to the gall bladder, the umbilical vein of the fetus does not persist, and the mode of distribution of the intercostal arteries is as in the pythons. In the latter species these characters are as in the Anaconda.

The anatomical differences may possibly seem slight to those not specially acquainted with the structure of serpents; but in the features mentioned there is, if anything, rather a greater difference between the two species of *Corallus* than between two admittedly distinct genera such as *Eryx* and *Python*. It is very desirable that the alleged close resemblance between other forms occurring both in Madagascar and in the neotropical region should be carefully scrutinised.

FRANK E. BEDDARD.

Zoological Society's Gardens.

The Interpretation of Mendelian Phenomena.

DR. ARCHDALL REID'S letter in *NATURE* of October 3 contains a very positive statement in reference to the relation of Mendelian phenomena to man, which I think should be immediately answered. I delayed supplying an answer because I wished to discuss his statement on a tangible basis. I desired to analyse certain data which I have been collecting, and which throw light upon the problem of segregation in man. This analysis is as yet incomplete, but it is sufficient to show that Dr. Archdall Reid is too confident when he asserts that "there is no segregation in man," and that, "with the exception of eye-colour, and possibly one or two other traits, such as the Mongolian eyelid, human hybrids appear to blend every character as perfectly as skin-colour."

The accounts which I have collected deal with various marriages between Europeans (chiefly Scotch) and the Canadian Red Indians. It is well known that many of the early European settlers in Canada married Red Indian women. The resulting half-breeds in their turn were in some cases intermarried, and in others mated to Europeans.

The Canadian Red Indians can be marked off from Europeans by six definite characters, which concern the nature of the hair, eyes, skin, cheek-bones, nose, and beard. The Indian hair is invariably black, long, glossy, and lank, and cannot be confounded with European hair; the eyes are almost invariably black or, very seldom, dark brown; the skin is tawny brown-yellow (varying from pale olive-yellow to dark brownish yellow); the cheek-bones are high (there is no obliquity to the eyes, thus differing from the Mongol); the nose is very prominent and broad at the base, and is of the *busque* type, that is, the profile is made up of two lines, which diverge widely from the bridge towards the base; and, lastly, there is either no beard or a very scant one of straight hairs on the face of the men. These characters, when well developed, are so different from the corresponding features in Europeans that they cannot easily be confused. No one, for instance, would mistake the long, lank, black hair and black eyes of the Indian for the thick red hair and blue eyes of some of the Scotch persons concerned in the histories now under review.

We may therefore use these six characters as differentiating ones, and may tentatively regard the Indian characters as being allelomorphous to the corresponding European ones. For the sake of brevity I will use symbols, which will have the following significance:—

I=Indian, E=European, H=hair, E=eyes, S=skin, C=cheek-bones, N=nose.

First, then, with regard to the matter of dominance. We must, in this case, be quite sure that the European concerned marries a full-blood Indian. In the cases which I have so far collected, I have only one marriage of such an Indian with a European, and there were only two children of the marriage. The European was a Highland Scot. His complexion was fair, and eyes blue. I have no information of the colour of his hair, since it was white with age when observed, but it was quite thick and not lank. In all the features (with the exception of the beard, of which I have no information) which mark off the Indian from the European, the son and daughter of this marriage were quite Indian.

So far, then, as this one case will take us, these five

Indian characters appear to be dominant over the corresponding allelomorphs of the European. This conclusion, however, receives corroboration from the results of marriages between Europeans and three-quarter blood Indians, when they are traced to the F_2 generation. There is thus no blending, even of colour, but dominance.

We can now deal with the important question of segregation. If segregation occurs in man, and we regard these five characters (the beard is excluded) as allelomorph pairs, then when a half-breed Indian (that is, the child of a European and Indian marriage) is mated with a European we should expect, among others, to find the following types in the offspring:—

- (1) Wholly European, EH, EE, ES, EC, EN.
- (2) Wholly Indian, IH, IE, IS, IC, IN.
- (3) European except in the cheek-bones, EH, EE, ES, IC, EN.
- (4) European except in the eyes and cheek-bones, EH, IE, ES, IC, EN.
- (5) Indian except in the nose, IH, IE, IS, IC, EN.
- (6) Indian except in the hair, EH, IE, IS, IC, IN.
- (7) Indian except in the skin and nose, IH, IE, ES, IC, EN.

And all these predicted seven types are to be found in the records of four marriages between an E and I which have been sent to me. A total of seventeen children are considered in this description.

It is perfectly clear that segregation of these five characters is taking place. There is no blending even of the colour of the hair, eyes, or skin. The blue eyes of a Scotchman who was mated to a full-blood Indian, and whose wholly Indian-type hybrid was mated in turn to a Welshman of hazel eyes, came out blue in two members of an offspring of eight children in the F_2 generation. That is clearly enough segregation.

If segregation is really occurring, and if the Indian features are dominant over the European, then it follows that once a pure European type has separated out and is mated with a European, Indian features ought not to appear among their offspring. In the records which I have there are two marriages of this kind, i.e. between E and extracted E. From one of these there have resulted five daughters, and from the other a son and a daughter. All seven are European in every trait. The recessive characters have thus far bred true.

These facts, therefore, are not only opposed to Dr. Archdall Reid's statement that there is no segregation in mankind, but they supply him with that instance of an appearance of a "latent" character in a cross between two "natural varieties" as contrasted to "artificial varieties" for which he seeks. For I suppose he will regard (if I may judge from the context of his letter) a cross between an $E \times I$, followed by a cross of $E \times$ extracted E, as crosses between natural varieties. At any rate, they are crosses between human varieties, and he denies rather too emphatically that "latent" characters have ever been revealed in such.

Dr. Archdall Reid is apparently not aware of Farabee's observation on the mating of albino negroes with pigmented negroes. The facts are important, so perhaps I may describe them. An albino negro married a normal negro. They had three children, all pigmented sons. These sons married, and two of them had only normal (pigmented) children; but the third son married twice, and by the first wife had five normal and one albino children, and by the second six normal and three albino children. If we assume that the two negroes which the third son married were themselves carrying albinism recessive (that is, in Dr. Archdall Reid's sense of the word, "latent"), the result is accurately in accordance, as Castle has shown, with Mendelian expectation. For, in the offspring of this third son, coloured individuals and albinos are expected in the proportion of 3:1. There is actually 11:4, which is the nearest possible approximation in an offspring of fifteen.

If Dr. Archdall Reid can explain these results, i.e. those of the Red Indians and the negroes, on any other theory than Mendelian segregation, or can even show that it is a case of an abnormality of sexual reproduction which occurs under conditions of "artificial selection," it will be of the most entrancing interest.

It may, of course, be objected that the negro case is one of the crossing of artificial and not of natural varieties. To me such an objection presents itself as a play with words. No one, I take it, will deny that if the conditions of the Mississippi region were favourable to albinism and unfavourable to pigmentation, a variety of albino negro would arise as permanent in its characters as any other natural variety of man. Besides, the albino case must be read with that of the Canadian Red Indian, and this is a natural variety as well as the European crossed with it. Both cases lead to the same conclusion.

Dr. Archdall Reid's doubt as to whether Mendelians "are engaged in anything more than the investigation of those abnormalities of sexual reproduction which occur under conditions of artificial selection" therefore becomes an assumption with an inadequate basis.

GEO. P. MUDGE.

Biological Laboratory, London Hospital
Medical College, October 21.

I HAVE already (NATURE, October 31) dealt with mutations, of which albinism is one. I have no first-hand acquaintance with Red Indian half-breeds. In the case of such characters as skin-colour and shape of nose and cheek-bones, even "when well developed," "the personal equation of the observer and the precision of his categories" have sometimes to be reckoned with. Having regard to the Mendelian doctrine of the independent inheritance of characters, does it not strike Mr. Mudge as singular that in the only example he possesses of marriages between E and extracted E all the offspring should be "European in every trait"? If his correspondent is correct, the Indian half-breed of the F_1 generation is "quite" indistinguishable from the full-blooded Redskin. I venture to appeal to readers of NATURE who have first-hand acquaintance with the facts. The information we need is not whether exceptional half-breeds of the F_1 generation resemble pure-blooded Indians, but whether this resemblance is the rule. Personally, I have a fairly large and close acquaintance with the half-breeds of Europeans on the one side, and negroes, Maoris, Kanakas, and several Asiatic races on the other. To my eyes, except in eye-colour, they are clearly distinguishable as half-breeds, though variations occur, and the dark race is sometimes approached rather closely. The case of eye-colour is remarkable. The black persists until one or more infusions of north European blood occur, when the light-coloured eye suddenly appears. So far as I am able to judge, though here I cannot speak with any degree of certainty, the quickness of the re-appearance of the light eye bears a relation to the degree of pigmentation of the dark race; that is, fewer infusions from the light-eyed race are required when it is crossed with the black-eyed European type than when it is crossed with the Asiatic, and more especially the negro. Whatever all this indicates—and I think I know, though lack of space forbids any attempt to entrance Mr. Mudge—very obviously it does not indicate Mendelian segregation. By latent characters I meant those long-lost ancestral traits which re-appear when domesticated races of rabbits, mice, pigeons, and the like are crossed.

G. ARCHDALL REID.

Newton's Rings in Polarised Light.

IN NATURE of October 24 (vol. lxxvi., p. 637) Mr. Edser asks whether anyone has tried the experiment of Lloyd's single mirror fringes with polarised light to see whether a change of the character of the fringes would occur on rotating the plane of polarisation of the light. Lloyd tried the experiment himself with light polarised by transmission through tourmaline, and observed no change in the appearance of the fringes (Lloyd, "Papers," p. 156). I have made the same experiment with Lloyd's fringes by internal reflection, and found no effect on rotating a Nicol prism through which the fringes were observed (*Phil. Mag.*, October, p. 507).

The change of phase for grazing incidence is π , whatever be the plane of polarisation of the incident light. The fringes, therefore, are of the same character for light of all kinds.

P. V. BEVAN.

Trinity College, Cambridge.

THE FISHES OF THE NILE.¹

THESE two handsome volumes are a tribute to the late Dr. John Anderson's zeal in the cause of Egyptian zoology, and a justification of the cordial support which he had from Lord Lister, Dr. Günther, Sir E. Ray Lankester, and Dr. Sclater in prevailing on the Egyptian Government to undertake the inquiry. The author, the collector and the artist are to be congratulated on this important contribution to African ichthyology. Moreover, the region embraced in the description, as shown in the two excellent maps of the Nile system—Upper and Lower—is one of great interest to the general zoologist, for it contains the sole survivors of an order (Polypteridae) abundantly represented from the Devonian to the Cretaceous, and includes one of the remarkable Dipnoans. It is an area in which the rare electrical fishes *Mormyrus* and *Malapterurus* (or, as the author has it, *Malopterurus*) are mingled with the subtropical and tropical *Gymnarchus*, the curious *Heterotis*, the *Characinidae*, the *Siluridae*, *Ophiocephalus*, the *Anabantidae*, and the *Cichlidae*; whilst by way of contrast these are associated with the cosmopolitan *Clupea finta* and *Mugil capito*, with the common *Anguilla vulgaris* and the ubiquitous *Morone labrax*. Yet these do not exhaust the sources of special interest, for not only were fishes, such as the Nile perch, preserved as mummies, their forms inscribed on ancient monuments or perpetuated in bronze models, but in this old-world country the number of fishes which carry and hatch their comparatively large ova and protect their young in the buccopharyngeal cavity is remarkable.

The problems connected with the origin and distribution of the fish-fauna are also replete with interest, and though many of these were dealt with by Mr. Boulenger in his valuable address to the zoological section of the British Association in South Africa, much yet remains for future workers both in substantiation and extension.

In the brief introduction the progress of the ichthyology of the Nile is described from 1757, the date of Hasselquist's "Iter Palestinum," when only thirteen species from the Delta were known. Without going into detail, they had mounted up to eighty-nine in Dr. Günther's account of the fishes of Petherick's expedition, but did not exceed a hundred when the Egyptian Government undertook the present survey. Now the total is 192, and no one has had a greater share in this increase than the author.

An important part of the introduction is the illustrated account given by Mr. Loat, the collector, of the methods of fishing in the Nile, the accumulated skill of many ages having given the native all the practical advantages of his art, so that in this respect he is not inferior to the English, American and Japanese. The throwing- or casting-nets, circle-nets, sweep-nets, modified trammel-nets, long nets like those for sand-eels with a median pocket, push-nets, conical wicker traps, elaborate weirs of stones which closely resemble those at present in use in Japan, besides baited and unbaited hooks, show how varied these methods are. It is not to be supposed, however, that

the casting-net is a novelty, for on the coast of Suffolk, for instance, an adept will throw it in a perfect circle. Mr. Loat collected no less than 11,000 specimens, and amongst these were thirty new species. Moreover, just as the Irish use the fatal spurge-root in their rivers, so the Egyptian pulverises the seeds of *Berbera* (or *Mellettia ferruginea*, or "Burberra," for poisoning fishes. In two or three hours thousands, it may be, rise to the surface.

The thorough method in which Mr. Boulenger treats his subject is apparent throughout; elaborate tables of twelve measurements, in addition to nine notes of the number of spines, rays and scales in different parts, accompany each species. He, however, evidently makes too much, at the expense of Rüppell and others, of De Johannis as a pioneer in Egyptian ichthyology, for this author's descriptions and figures have much that is incorrect in them. Moreover, there is a tendency to split species where others group them, and to group them where others split them, the latter being just the fault he himself lately criticised, and with justice, in Smitt. Further, insignificant specific variations between the Nilotic fish-fauna and that of West Africa need not be insisted on too strongly where, as pointed out long ago, the similarity is so great. In looking at the slight diversities between such species as *Marcusenius discorhynchus*,



FIG. 1.—Fishing at the mouth of the Sobat. From "The Fishes of the Nile."

chus, *M. petherici*, *M. budgetti*, and *M. tanganicus*, the thought involuntarily asserts itself that in the future a different view may be taken of their relationships. Again, there are cases in which the indefatigable author has examined 100 to 200 examples of a fish normally possessing ten to eleven dorsal rays, but he finds that three or four per cent. have seven or eight rays only. It is surely unsatisfactory to describe such a fish as possessing D. 7-10. A more correct method would have been to record it as Dr. Günther has done, viz. D. (7-8) 9-10.

One of the most interesting features in the Cross-opterygians is the frequent allusion to the labours of the lamented Mr. J. S. Budgett, who contracted a fatal illness whilst pursuing his valuable work on the development of the group in the Niger Delta. Considerable advances have been made in the Dipnoans, that of the Nile (*Protopterus aethiopicus*) differing in habit from *P. annectens* of the West Coast. Of Teleosteans there are nineteen families, and the author gives two classifications, (1) an anatomical, and (2) one based on external characters. Both are valuable. The first family of the Malacoopterygians is the generalised *Mormyridae*, remarkable for the large size of the brain and the "problematic organ" above it, as well as for their electric organ. Four families, each repre-

¹ Zoology of Egypt. The Fishes of the Nile." By G. A. Boulenger, F.R.S. Vol. I., text, pp. 11+578; vol. II., plates, pp. xviii+97 plates. (London: Published for the Egyptian Government by Hugh Kees, Ltd., 1907.) Two vols., price 5*l.* 2*s.* net.

sented only by a single species, follow, the last being *Cromeria*, distinguished from the *Galaxiidae* of the *Haplomi* by the presence of a mesocoracoid (Swinnerton). The family of the *Characinidae* (under the *Ostariophysii*) form a very generalised group confined to the fresh waters of Africa and Central and South America, from which the author thinks they may have migrated by a land connection in Upper Cretaceous times. These supposed precursors of the *Cyprinoids* number eighteen species in the Nile.

The widely distributed family of the *Cyprinidae* comprises the largest number of species within its limits, viz. fifty, and thirty-five of these belong to the genus *Barbus*, a large proportion, seeing that in Day's "Fishes of India and Neighbouring Regions" there are but seventy. Yet the genus is conspicuous by its absence from the Senegal, the Gambia, and Lake Chad. The author's wealth of material has enabled him to clear up the synonymy of certain species, such as *Lates coubie*, yet it is doubtful if, as in Europe, hybridism may not occur to a greater extent than is at present imagined. The representatives of the genus

lenger, during the last few years from twenty species to 210 in Africa, and of these eighteen belong to the Nile. The author considers that the forms inhabiting that great lake (Victoria) sprang from a small number of original (isolated) types, and were modified into a multitude of species according to lines different from those followed by other colonies. Only two or three of these are identical with or very closely related to forms in neighbouring rivers.

Though many interesting facts in regard to reproduction and development are incidentally noted in this fine work on Nile fishes, especially in connection with Mr. Budgett's investigations on *Polypterus*, *Protopterus*, and on the breeding of the *Mormyridæ*, very much yet awaits the observer in this department, and no more fascinating field exists, to judge from the fragmentary knowledge available. Some, like *Hyperopisus bebe*, attach their oval eggs to rootlets of grass, and the larvæ hang in thousands, like amphibians, to the rootlets until the yolk-sac is absorbed. Others have floating nests 2 feet long by 1 foot broad (*Gymnarchus niloticus*) for eggs 10 mm. in diameter, and for larvæ with long gill-filaments. A still larger nest (4 feet in diameter) characterises *Heterotis niloticus*, the larvæ of which also have gill-filaments. The eggs of *Cyprinodon fasciatus* have long filaments, like those of the garfish, which entangle them in masses or suspend them to various objects. The large number of fishes which carry their ova and larvæ in their bucco-pharyngeal cavity is a prominent feature, and Mr. Boulenger has found that it is almost invariably the female which does so, not the male, as in such forms as *Arius*. In some cases (*Haplochromis strigigena*) the male makes a small cavity in the sand where the eggs are fertilised, the female thereafter taking them into her mouth, and fasting for a fortnight. Yet animals much lower in the scale than fishes do almost the same thing, as in the case of *Asterias Müllerii*, the fertilised eggs and larvæ of which are borne in a mass by the parent over the mouth. The



FIG. 2.—Throwing-net as used on the Lower Nile. From "The Fishes of the Nile."

Barbus, of which there are no fewer than twenty-seven new species in the work, offer a wide field for the features just mentioned, since many are very closely allied, though separable, perhaps, by such points as the proportions of the snout. The tropical or sub-tropical *Silurids* are largely represented by fifteen genera and forty-one species, and the habits of some, such as *Clarias*, are full of interest, for they spend the dry season in burrows in dried-up marshes, which they leave at night in quest of food—both animal and vegetable—using the spines of the pectorals in progression. The name *Malapterurus* has so long been used that the author's change to *Malopterurus jara*, and for similar reasons he himself does not follow Starr Jordan in calling the species "*Torpedo*" *electricus*. It is noteworthy that whilst the fresh-water species are all generically distinct from the American, those species which enter the sea on both shores of the Atlantic agree (e.g. *Arius*). The *Cichlidae*, a family which presents great difficulties from the close resemblances of many—e.g. those of Lake Victoria—have increased, largely by the labours of Mr. Bou-

lenger, during the last few years from twenty species to 210 in Africa, and of these eighteen belong to the Nile. The author considers that the forms inhabiting that great lake (Victoria) sprang from a small number of original (isolated) types, and were modified into a multitude of species according to lines different from those followed by other colonies. Only two or three of these are identical with or very closely related to forms in neighbouring rivers. Though many interesting facts in regard to reproduction and development are incidentally noted in this fine work on Nile fishes, especially in connection with Mr. Budgett's investigations on *Polypterus*, *Protopterus*, and on the breeding of the *Mormyridæ*, very much yet awaits the observer in this department, and no more fascinating field exists, to judge from the fragmentary knowledge available. Some, like *Hyperopisus bebe*, attach their oval eggs to rootlets of grass, and the larvæ hang in thousands, like amphibians, to the rootlets until the yolk-sac is absorbed. Others have floating nests 2 feet long by 1 foot broad (*Gymnarchus niloticus*) for eggs 10 mm. in diameter, and for larvæ with long gill-filaments. A still larger nest (4 feet in diameter) characterises *Heterotis niloticus*, the larvæ of which also have gill-filaments. The eggs of *Cyprinodon fasciatus* have long filaments, like those of the garfish, which entangle them in masses or suspend them to various objects. The large number of fishes which carry their ova and larvæ in their bucco-pharyngeal cavity is a prominent feature, and Mr. Boulenger has found that it is almost invariably the female which does so, not the male, as in such forms as *Arius*. In some cases (*Haplochromis strigigena*) the male makes a small cavity in the sand where the eggs are fertilised, the female thereafter taking them into her mouth, and fasting for a fortnight. Yet animals much lower in the scale than fishes do almost the same thing, as in the case of *Asterias Müllerii*, the fertilised eggs and larvæ of which are borne in a mass by the parent over the mouth. The Egyptian fishermen, however, explain the presence of the ova in the mouth of the fishes very simply, viz. by a "reversed method of parturition." The whole subject, from the development of the nuptial tubercles in the males to the post-larval stages of these remarkable Nile fishes, bristles with features of interest. In addition, the field of fish-physiology is inviting. Why is it that *Polypterus bichir* (a fish which dies in tolerably fresh water if prevented from reaching the air) cannot live in brackish water, and that slight salinity kills it? whilst one species of fish in Lake Menzaleh thrives either in fresh or salt water, and another dwells equally in a hot spring at Makulla, in the Persian Gulf, and in salt water all round the Red Sea. The author takes in hand the explanation of the peculiar coloration of *Synodontis batensoda*, in which the ventral aspect of the body is darker than the upper, viz. as a provision in connection with the habit of swimming in a reversed position. Yet this explanation will not avail for the post-larval *Callionymus*. Again, are the habits of *Anabas* in Africa similar to those in India?

The able author has brought to the task not only his former experiences of African fishes—north and south, east and west—but the whole resources of the British Museum, and the vast storehouse of information amassed during the lifelong labours of Dr. Günther, and he has accomplished it in a manner creditable to the Egyptian Government, to science, and to himself. His work, indeed, will long form the basis of future labours in the ichthyology of the Nile. The whole of the families are as admirably illustrated as described in the beautiful volume of lifelike lithographs by Messrs. Smit and Green, their work rivaling the exquisite finish of the late G. H. Ford, long *facile princeps* in the department. Finally, if any suggestion may be made in a work so carefully performed, it is that in the index the synonyms might have been printed in italics, and that, in the text, plate xiv. should be substituted on p. 84 for plate xv.

W. C. M.

SOME RECENT PAPERS ON METEORITES.

WE have before us a number of reprints of recent papers descriptive of various meteorites. Several of these are by the late Dr. Henry A. Ward and the late Prof. E. Cohen, two of the most indefatigable workers in this subject, whose loss is much to be deplored. In 1904, two years before his death, Dr. Ward published a "Catalogue of the Ward-Coolney Collection of Meteorites," which is not only a catalogue, but contains, in addition, much useful information, including alphabetical and topographical lists of all known meteorites (about 680 in number). The Ward-Coolney collection, now exhibited in the American Museum of Natural History at New York, is one of the most complete that has ever been made, containing as it does representatives of 603 meteoritic falls; it is further remarkable in that it was brought together in the comparatively short space of time of ten years. Prof. Cohen died in 1905, and a third part of his "Meteorisenkunde" was published after his death; this, which is the only general work that has yet been attempted on meteorites, unfortunately remains incomplete.

Dr. H. A. Ward (Proc. Rochester Acad. Sci., 1904, vol. iv., pp. 137-148, with 6 plates) gives a description of the Willamette meteorite, which was found in 1902 near the town of Willamette, in Oregon. This mass of metallic nickel-iron measures $10 \times 6\frac{1}{2} \times 4\frac{1}{2}$ feet, and weighs 31,107 lb. (about $15\frac{1}{2}$ tons); it is the third largest meteorite as yet known. Like the largest on record, the Anighito, of $36\frac{1}{2}$ tons, brought by Commander R. E. Peary from Cape York, in Greenland, it is now exhibited in the American Museum of Natural History. The second largest known meteorite is that of Bacubirito, in Mexico, which has an estimated weight of $27\frac{1}{2}$ tons; this mass, though unearthed and described by Dr. Ward in 1902, has not been removed from the place where it was found. The Willamette meteorite is roughly conical in form, and it was found embedded in the ground with the base of the cone uppermost, suggesting that the apex of the cone was to the front of the falling meteor. The mass is remarkable for the deep, rounded, and cylindrical pits, of which several types are distinguished, on the sides and the base of the cone. The deep cavities on the base (Fig. 1) are accounted for by the weathering and rusting action of water standing in pools on the exposed part of the mass as it lay for unknown ages in the soil of the primeval forest of a very moist region. The pittings and groovings on the sides are attributed by the author to the erosive action of the air during the flight of the meteorite; but it seems more likely that they have been produced by weather-

ing in the ground, and that none of the original surface now remains. The nodules and rods of troilite (iron sulphide) enclosed in the metallic iron no doubt formed the centres around which the weathering has proceeded. The Widmanstätten figures on an etched section of the iron show the structure to be octahedral with broad lamellae. The specific gravity of the iron is 7.7, and it contains $9\frac{1}{2}$ per cent. of iron, 8 per cent. of nickel, and small amounts of cobalt and phosphorus.

Dr. H. A. Ward (*ibid.*, 1905, vol. iv., pp. 193-202) also gives an account of the Bath Furnace aërolite,

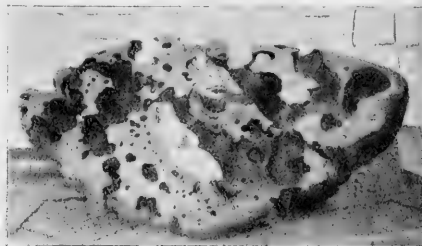

FIG. 1.—Willamette Meteorite. Full view, lower side of meteorite.

which was observed to fall on November 15, 1902, in the vicinity of Bath Furnace in Bath co., Kentucky, the fall being accompanied by a blinding light, loud detonations, and hissing noises. In all, three stones were found; one of them, weighing nearly 13 lb., struck the hard surface of a road, making an east to west furrow about a foot in length and five inches in greatest depth. Another mass of 177 $\frac{1}{2}$ lb. fell $1\frac{1}{2}$ miles further south; it scarred the trunk of one tree, cut through the roots of another, and buried itself two feet in the ground. A side view (Fig. 2) of this larger



FIG. 2.—Bath Furnace Meteorite. Side view, showing furrows radiating from apex.

stone shows very clearly a system of furrows radiating from the apex, which were produced by the intense erosive action of the air during the flight of the stone. The internal structure of the Bath Furnace meteorite is that of a spheroidal chondrodite like that of the three previously known meteorites (Werchne Tschirskaja, South Russia, 1843; Trezzano, Italy, 1856; and Saline Township, Kansas, 1898), which fell during the November Leonids. Both the Bath Furnace and the Willamette meteorites gave rise to suits at law between the finders and the land owners. In other papers, Dr. Ward describes some new Chilian

meteorites, and also gives general notes on the history of meteorites and collections of meteorites, especially as regards the aims of the latter.

Prof. E. Cohen (Ann. S. African Museum, 1906, vol. v., pp. 1-16, with 3 plates), describes the meteoric stone of 30½ lb. which was observed to fall on January 3, 1903, at the mission station of St. Mark's, in Transkei, Cape Colony. The description of the microscopical structure and chemical composition of this stone was completed by Prof. C. Klein, another well-known worker on meteorites, who also died recently (1907).

Mr. L. L. Fermor (Records Geol. Survey India, 1907, vol. xxxv., pp. 79-96, with 12 plates) collects together information respecting the circumstances of the fall of various Indian meteorites, and gives brief notes on their external characters. At greater length (*ibid.*, pp. 68-78, with 3 plates) he describes the fall of stones near Dokachi, in Bengal, on October 22, 1903; here, along a line six miles in length, twenty-four fragments, with a total weight of 3838 grams, were picked up. A list is given of seventy-one meteoritic falls recorded in India since 1798; more records exist in later years, and in the more thickly populated districts, and latterly they have averaged one each year. All, except three, of these Indian meteorites are composed of stony material.

Prof. O. C. Farrington (Field Columbian Museum, Geol. Ser., 1907, vol. iii., pp. 57-110) collects together 360 published analyses of 248 meteoric irons, tabulating them in different classes according to the structure of the iron. It is then seen that there exists a close relationship between chemical composition and structure. All irons with a hexahedral structure are very uniform in composition (0.4-12 per cent. Fe), whilst in those with an octahedral structure the amount of nickel increases with the fineness of the lamellæ. In the ataxite group, in which the structure is finely granular to compact, there is more variation in composition. The average composition of all meteoric irons is approximately Fe, 90; Ni, 9; Co, 0.9; Cu, 0.02 per cent. The same author also describes in detail in the same journal the siderite of Rodeo, Mexico (found 1852), the siderolite of South Bend, Indiana (found 1893), and the aërolite of Shelburne, Ontario (fell August 13, 1904).

The papers on meteorites noted above are but a few selected at random from the many that have been recently published: except in details, one paper is, however, more or less a repetition of another.

L. J. S.

NOTES.

The president and council of the Royal Society have recommended the following fellows for election as members of the council for the ensuing year at the anniversary meeting on November 30:—*President*, Lord Rayleigh, O.M.; *treasurer*, Mr. A. B. Kempe; *secretaries*, Prof. J. Larmor, Sir Archibald Geikie, K.C.B.; *foreign secretary*, Prof. J. R. Bradford; *other members of council*, Dr. H. F. Baker, the Right Hon. A. J. Balfour, Sir William Crookes, Mr. Francis Darwin, Sir George Darwin, K.C.B., Prof. J. C. Ewart, Prof. D. Ferrier, Mr. C. T. Heycock, Prof. S. J. Hickson, Prof. J. Joly, the Hon. C. A. Parsons, Dr. A. Scott, Prof. A. C. Seward, Prof. F. T. Trouton, Dr. A. D. Waller, Mr. W. Whitaker.

The late Dr. Edward Sang's collection of MS. calculations in trigonometry and astronomy has been gifted to the British nation by the Misses Sang, and the president and council of the Royal Society of Edinburgh have been appointed custodiers of the collection, with power to

publish such parts as may be judged useful to the scientific world. The society has also been given custody of the duplicate electrotype plates of Dr. Sang's 1871 new seven-place table of logarithms to 200,000, with power to use them for reproducing new editions, or publishing extended tables of seven-place logarithms. At the meeting of the society on November 4, the chairman, Dr. R. H. Traquair, F.R.S., read a statement regarding Dr. Sang's monumental work. The manuscript volumes number forty-seven in all, the contents of thirty-two of which are in transfer duplicate. Vols. i. to iii. contain the details of the steps of the calculations on which the results contained in the next thirty-six volumes are based. Vol. iv. contains the logarithms, calculated to twenty-eight figures, of the prime numbers up to 10,000, and a few beyond. Vols. v. and vi. contain the logarithms to twenty-eight figures of all numbers up to 20,000. From these the succeeding thirty-two volumes are constructed, giving the logarithms to fifteen places of all numbers from 100,000 to 370,000. This colossal work must ever remain of the greatest value to computers of logarithmic tables. It is a great national possession. The other tables in the collection are trigonometrical and astronomical. Of special interest are the tables of sines and tangents calculated according to the centesimal division of the quadrant. It is hoped that ere long some of these tables may be published in such a form as to make them more immediately accessible to computers. They are the foundation of Dr. Sang's unpublished book of seven-place logarithms to 200,000, undoubtedly the most perfect of its kind ever printed. The complete account of the various tables will be printed in the society's Proceedings, and other scientific bodies will have their attention directed to the importance of the collection now in the custody of the society.

THE Huxley memorial medal of the Royal Anthropological Institute was presented to Prof. E. B. Tylor, F.R.S., on Tuesday, November 5, in recognition of his distinguished services to anthropology. On October 2 Prof. Tylor celebrated his seventy-fifth birthday, and the anniversary was made the occasion of the presentation to him of a volume of essays representative of British anthropology. The current volume of the Journal of the Royal Anthropological Institute is dedicated to Prof. Tylor; and the presentation of the Huxley memorial medal is another mark of the esteem in which he is held by anthropologists.

SIR OLIVER LODGE has accepted the invitation of the council of the Faraday Society to succeed the late Sir William Perkin as president of the society.

ON October 20 the Paris newspaper *l'Éclair* liberated 10,000 pilot balloons from a boat on the Seine. One of these balloons was found at mid-day on October 21 at Undermannlaani, near Kausala, which is on the railway mid-way between Helsingfors and Wiborg, in Finland. The distance is 1950 kilometres. The balloon was found twenty hours after the start, and, assuming that it had only just fallen, the average rate was nearly 100 kilometres per hour. The lift of the balloons, including weight of postcard, &c., was supposed to be about 1 gram, but departures from this value must have been frequent, for Mr. Charles J. P. Cave, who witnessed the ascents and sends us these particulars of them, states that the rates of ascent of different balloons varied greatly. The diameter of the balloons was about 35 centimetres. The greatest distance covered by a manned balloon is 1025 kilometres, in the ascent of Count de la Vaulx from Vincennes on October 9, 1900.

The *Pioneer Mail* states that the Secretary of State for India has sanctioned the establishment of a new bacteriological department on a permanent basis.

It is reported that the town of Karatagh, in Bokhara, was destroyed by an earthquake on October 21. A message from New Bokhara states that 600 farmsteads have been destroyed, and 200 persons killed.

The FitzPatrick lectures of the London Royal College of Physicians will be delivered by Dr. Leonard Guthrie on December 3 and December 5, on "Contributions from History and Literature to the Study of Precocity in Children."

It is reported by *Science* that the observatory of the University of Michigan is being enlarged under the direction of Prof. Hussey. The old instruments are being reconstructed, and a new reflecting telescope added, having an aperture of about 37½ inches.

From the *Pioneer Mail* we learn that the Government of India has sanctioned the opening of wireless telegraphic communication between Mergui (Lower Burma) and Victoria Point, with a land line between Victoria Point and Maliwun. An annual guarantee will be given from the provincial revenues of Burma in respect of the combined system. The guarantee will be subject to reconsideration at the end of ten years.

The opening meeting of the Institution of Electrical Engineers will take place on November 14 at the Institution of Civil Engineers, Great George Street. Lord Kelvin is president for the present session, this making the third time he has occupied the presidential chair. Owing to his absence no presidential address will be given at the opening meeting, but a paper on the dielectric strength of insulating materials and the grading of cables will be read by Mr. A. Russell.

The council of the Institution of Civil Engineers has made the following awards for the year 1906-7:—the Howard quinquennial prize to Mr. T. E. Vickers, C.B., in recognition of the part he has taken during his career in developing and improving the production of steel for important engineering purposes; Telford gold medals to Mr. Dugald Clerk (London) and Mr. E. J. Way (Johannesburg); Watt gold medals to Mr. J. T. Milton (London), Dr. A. W. Brightmore (Egham), and Mr. C. W. Lloyd-Jones (Secunderabad); George Stephenson gold medals to Mr. G. A. Hobson (London) and Mr. W. C. Copperthwaite (London); Telford premiums to Messrs. C. F. Jenkin (London), W. A. P. Tait (Edinburgh), A. P. Trotter (London), M. Kellow (Penrhyn-deudraeth), H. J. S. Heather (Johannesburg), A. M. Robeson (Johannesburg), and J. W. Kitchin (Bristol); a Crampton prize to Mr. R. F. Thorp (London); Manby prizes to Mr. S. A. Frech (London) and Mr. G. D. McGlashan (Blyth); the Miller scholarship and the "James Forrest" medal to Mr. A. C. Anderson (Wolverhampton); Miller prizes to Messrs. R. A. Whitson (Basutoland), C. A. Ablett (Addiscombe), E. H. Heathcote (Henbury, near Macclesfield), G. B. G. Hull (Stockport), H. Stringer (Stoke-on-Trent), G. F. Walton (Edenfield, near Manchester), and A. T. Weston (Woolwich); Bayliss prizes, awarded on the results of the October and February examinations, 1906-7, respectively to Mr. F. C. R. H. Boyd (Luxor, Upper Egypt) and Mr. D. J. Morris (Swansea).

The inaugural address of the eighty-ninth session of the Institution of Civil Engineers was delivered on Tuesday evening, November 5, by the president, Sir William

Matthews, K.C.M.G. In the course of his remarks, the president referred to certain branches of engineering which are associated with the conduct of over-sea traffic, and therefore have an intimate and important bearing on our maritime commerce. In the ships of our mercantile marine we may with certainty look for expansion both with regard to dimensions and numbers. Again, we are fully entitled, in the light of recent events, to anticipate in the immediate future further and possibly great developments in steam propulsion with turbines, either employed alone or associated with reciprocating engines. Then there is the extended use of oil for raising steam, or directly in internal combustion engines. With regard to harbours, docks, and waterways, due and adequate provision must be made for larger and deeper draught ships, in the designs to be prepared for new works, and also where harbours and docks exist of inadequate dimensions for present requirements. As to the actual construction of sea-works, the arrangement of their design so that their execution may entail, so far as possible, repetitions of the same process, with the use of heavy masses and the generous application of suitable plant, may be usually expected to produce satisfactory and economical results, so far as the structures themselves are concerned.

The awards for the Marseilles International Oceanographic Exhibition, which was held last year, have been issued. Among the recipients we notice the following:—*Grand Prix d'Honneur* to the Admiralty, the British Museum (Natural History), Meteorological Office, Sir John Murray, K.C.B. (president of the British Committee), Fishery Board for Scotland, Department of Agriculture for Ireland. *Grand Prix* to the Scottish National Antarctic Expedition, Challenger Society, Marine Biological Association, Royal Geographical Society, Captain Scott, R.N., Dr. Herbert Fowler (honorary secretary of British Committee), and Mr. W. S. Bruce. In addition, the *Diplôme Commémoratif* has been awarded to about thirty individuals and societies.

The South Wales Institute of Engineers celebrated its jubilee on October 29. The institute was founded at Merthyr on that date of 1857 by the late Mr. Wm. Menelaus, manager of the Dowlais works. A strong and representative executive was formed, every member of which has now passed away. In 1881 a charter of incorporation was obtained, and in 1894 the institute buildings were opened at Park Place, Cardiff, at a cost of more than 10,000*l.*, whilst the new library added last week has cost another 500*l.* The present membership is 565. Sir W. T. Lewis, who was present at the first meeting of the institute, became in later years its president. The present holder of that office is Mr. T. H. Deakin, and secretary Mr. T. Jones-Price. The library was formally opened by the president on the afternoon of October 29, and a portrait of the founder of the institute (by Mr. Parker Hagarty) was unveiled. Addresses were delivered by Mr. T. Hurry Riches, Mr. Henry Martin, Mr. McMurtrie, and others. The quarterly meeting was then held, and in the evening there was a *conversazione*, at which there was a crowded attendance. Several lectures were delivered by Principal Griffiths, F.R.S., Dr. Hampson, Dr. Perman, and Mr. S. W. Allen. Among other interesting features was an installation of electrophones "laid on" to the London opera and music halls. Sir W. T. Lewis, who was unavoidably absent, sent a congratulatory letter, in which he referred to the fact that the South Wales coal output to-day was nearly seven times its figure at the time of the foundation of the institute.

THE fourth International Fishery Congress will be held at Washington on September 22-26, 1908, on the invitation of the United States Bureau of Fisheries. The first congress was held at Paris in September, 1900, the second was held at St. Petersburg in 1902, and the third at Vienna in 1905. Persons who expect to attend the congress or to submit papers are asked to communicate with the secretary-general as soon as practicable, and the secretaries of institutions and organisations interested in the work of the congress are requested to register their official designation and address so that they may receive further announcements, programmes, invitations, &c. The congress will deliberate on all important affairs concerning fishing and fish culture, and will submit propositions and memorials to Governments and to provincial and local authorities. The subjects to be brought before the congress may be grouped as follows:—(1) commercial fisheries; (2) matters affecting the fishermen and the fishing population; (3) legislation and regulation; (4) international matters affecting the fisheries; (5) aquaculture; (6) acclimatisation; (7) fish-ways and fish-ladders; (8) biological investigation of the waters and their inhabitants; (9) diseases and parasites of fishes, crustaceans, molluscs, and other water animals; (10) angling and sport fishing. In connection with the congress there have been arranged a number of competitive awards for the best or most important investigations, discoveries, inventions, &c., relative to fisheries, aquaculture, ichthyology, fish pathology, and related subjects during the years 1906, 1907, and 1908. The awards will be in the form of money, and aggregate about 440l.; and, although the individual amounts are not large, it is hoped that the conferring of the awards by so representative a body as the International Fishery Congress will induce many persons to compete, and will result in much benefit to the fisheries and fish culture. Communications regarding the congress should be addressed to the Secretary-General, International Fishery Congress, Washington, D.C., U.S.A.

A REMARKABLE hailstorm occurred in Cairo on the evening of October 21, preceded by lightning from 6 p.m. to 7.30 p.m. The hailstones measured on an average about 25 mm. in diameter, the largest stones measuring up to 35 mm. The storm was very violent, but only lasted a quarter of an hour. Had it been of longer duration considerable damage would have been inevitable. Such storms are very rare in Egypt. Coming after many hot, rainless months, the sudden downpour of hail caused great excitement amongst the natives. The hailstones fell on the flat-roofed houses with a loud crackling sound resembling that of burning wood-work. Newspapers spread out to catch the falling hail were simply riddled through by the larger stones. Most of the hailstones were spheroidal in shape with white nuclei. After striking the ground they quickly became hemispherical. The temperature in Cairo at the time was 25° C. The weather report issued by the Egyptian Survey Department does not indicate anything exceptional in the general weather conditions before or after the storm. The barometer was nearly normal, with short periodic disturbances between 5 p.m. and 8 p.m. The atmosphere was slightly clouded, and a light wind blowing. The hailstorm was very limited in extent, and apparently the path was N.W. to S.E. The temperature at various altitudes is variable, depending upon meteorological changes, but in ordinary circumstances the rate of change of temperature with altitude amounts to 1° C. for each 100 metres for the first 1500 metres. This would give about 2500 metres as the minimum height for the formation of ice. A systematic exploration of the atmo-

sphere by means of kites and captive balloons with self-recording instruments is now being undertaken by the energetic director of the Helwan Observatory which will greatly extend our knowledge of the upper air over north-east Africa.

WE have received a copy of a paper by Mr. J. F. Bovard, issued as No. 14 of the third volume of the University of California Zoological Publications, on the structure and movements of *Condylostoma patens*, one of the largest of unicellular organisms.

A WRITER in the October number of the *Zoologist* figures a specimen of the "false scorpion," *Chelifer caneroides*, taken last year in a bake-house at Manchester. Up to the year 1892 only four British examples of this creature were known, but since that time the species has been discovered in stables, stores, &c., in various parts of England and Scotland.

"A MONOGRAPH OF THE PETRELS" is the title of a quarto work, by Mr. du Cane Godman, to be published in parts by Messrs. Witherby and Co., of High Holborn. It is to include all the known species of petrels, shearwaters, and albatrosses, and will be illustrated by more than one hundred hand-coloured plates. Mr. Godman's former colleague, the late Mr. Osbert Salvin, contemplated issuing a work of this nature, for which a number of plates were prepared; these will be used in Mr. Godman's volume.

WE have received a copy of a paper, by Mr. H. B. Greene, on the influence of heredity on the diseases and deformities of poultry, issued in connection with the second National Poultry Conference held in July last. From the fact of the isolation of the germ-cells, diseases are not, in the author's opinion, transmissible through the egg, and they must accordingly be regarded as the effects of environment rather than of inheritance. This is distinctly encouraging to the poultry-breeder, as it indicates that much may be done in the way of preventing disease by careful attention to food and sanitation.

AMONG the contents of *Verhandlungen deutsch. zool. Ges.* for 1907, we may refer to a paper by Dr. Steche, of Leipzig, on two luminous fishes, *Photoblepharon palpebratus* and *Heterophthalmus catoptron*, from the Malay Archipelago. Both species are of small size, and belong to the family of horse-mackerels (Carangidae); they are remarkable among luminiferous fishes in being shallow-water forms, the first-named dwelling among stones at the bottom, while the second is a free-swimmer. Their light-organs, which are situated in the cutis, resemble generally those of deep-water luminous fishes, though they have certain structural peculiarities of their own. The whole upper surface of these fishes appears to be luminiferous.

A LARGE portion of vol. xlix. of the Smithsonian Miscellaneous Collections is occupied by an account of the crabs collected by the North Pacific exploring expedition of 1853-6. Dr. W. Stimpson, it appears, accompanied the expedition as naturalist, and after his return transferred the invertebrate collections to Chicago, where, together with notes and drawings, they were burnt in 1871. After his death in the following year an illustrated report on the crustaceans was discovered, and it is this report which has just been published by the Smithsonian Institute. The only additions to the original MS. are references to Stimpson's preliminary descriptions of species and certain emendations in nomenclature. Among the

generic names we may refer to *Ptychognathus*, which was published in 1858, and therefore antedates and invalidates Owen's use of that term for a South African anodont reptile.

In a supplemental Bulletin (No. 3) on "leaf-hoppers," recently issued by the Experimental Station of the Hawaiian Sugar Planters' Association at Honolulu, Mr. G. W. Kirkaldy suggests that the Australasian zoological region should be subdivided as follows:—(1) Austro-Malayan, or Papuan, including, in addition to the limits laid down by Wallace, the tropical forests of Queensland, and New Caledonia and the neighbouring islands as far as Fiji; (2) Euronotian, comprising Tasmania and the south-eastern third of Australia; (3) the Maorian, embracing New Zealand and adjacent islands; (4) the Westralian. The Caroline, Marshall, and Marianne groups may be provisionally included in the Austro-Malayan sub-region, while the Hawaiian Archipelago forms an unattached subregion of great antiquity. Fiji seems to be related, as regards fauna, to the Papuan Archipelago or to the tropical forest of East Australia, and Wallace's Polynesian subregion should accordingly be abolished. Celebes is perhaps best regarded as an unattached or intermediate subregion.

A LIST of sedges from Jamaica, compiled by Dr. N. L. Britton from specimens examined in herbaria in New York and London, has been published as a supplement to the fifth volume of the Bulletin of the Department of Agriculture, Jamaica. With regard to previous determinations, Dr. Britton follows in the main the monograph on West Indian Cyperaceæ by the late Mr. C. B. Clarke, published in Urban's "Symbolæ Antillanæ" in 1900, but prefers a broader acceptance of the genus *Cyperus*. Fifteen genera and about a hundred species are enumerated, of which some require confirmation from additional specimens.

IN the October number of the *Trinidad Bulletin* the editor notes, with regard to the species *Theobroma angustifolia* allied to the cacao, that while the fruit is useless for commercial purposes, the tree, being more robust and resistant, is likely to prove useful as grafting stock for cacao plants. Reference is also made to an ornamental grass, *Thysolæna agrostis*, introduced from America, that may be grown in clumps similar to pampas grass. The report by Mr. F. A. Stockdale, mycologist to the Imperial Department of Agriculture in the West Indies, on the palm diseases investigated in Trinidad is published in full. Of the three diseases recorded, the most serious is the root disease caused by a fungus assigned to *Botryodiplodia*, a genus included in the Sphaeropsidæ.

It is reported in the daily papers that Prof. Koch, who is returning home after a long sojourn in the sleeping-sickness districts of Uganda, regards sleeping sickness as an enormous danger to the whole of East Africa. He finds that the tsetse-fly, the *Glossina palpalis*, which conveys the disease, breeds not only on the lake shores, but along the whole length of the rivers. Prof. Koch considers that there is a distinct connection between crocodiles and sleeping sickness. Wherever crocodiles are found the disease may be discovered, but only in places near the water. The blood of crocodiles forms the chief nourishment of the *Glossina*, which sucks the blood between the plates of the animal's hide. The extermination of the *Glossina* is impossible, but it is suggested that the same end may be reached by destroying the crocodiles or by the removal of the bushes and undergrowth where the animals lurk.

NO 1984. VOL. 77]

No one more fully understands the danger of indiscriminately using a *questionnaire* than Dr. J. G. Frazer, who in publishing through the Cambridge University Press his "Questions on the Customs, Beliefs, and Languages of Savages" is careful to point out the true method of utilising them. They are intended, not so much to be put directly to the savage, as to indicate to the inquirer in the field those subjects upon which students at home desire information. Leading questions should be avoided, as they tempt the savage to give answers which he thinks will be acceptable. The savage should be encouraged to talk in his usual vague way on the subject under investigation until he has exhausted his information for the time, when a question judiciously asked may jog his memory. Unexpected information casually offered is the most valuable of all, "first, because not being foreseen by the civilised man it cannot have been consciously or unconsciously suggested by him to the savage; second, because it may put an entirely fresh complexion on a whole series of customs and beliefs about which we had fancied that we knew all that was worth knowing." If used with this much needed caution, this suggestive collection, which is supplementary to the manual issued by the Royal Anthropological Institute, will be of much value to travellers with a taste for investigating the manners and customs of savage or semi-savage races.

STRIKING evidence of the industrial advantage of the occupation of the Philippines by the United States is afforded by a copiously illustrated article on railway development in the Philippines, by Mr. P. H. Ashmead, in the *Engineering Review* (vol. xxxiii., No. 6). The construction of the railways under Government patronage cannot fail to be of permanent benefit. The vast sums distributed as wages will be spent in the islands. An industrial army of some 30,000 men will have been formed, and such of these as are not required in the working of the railways will be available for other industries, which will receive an impetus by the supply of cheap means of transport.

THE Royal Cornwall Polytechnic Society, of which the seventy-fourth annual report has been received, continues to carry on successfully the valuable work in promoting the commercial prosperity of Cornwall and in encouraging mining invention for which it was brought into existence. The annual exhibitions of the society do much to stimulate inventive genius, and from the report on the seventieth exhibition it is seen that in view of the increased mining activity in the county special attention was devoted to life-saving appliances in mines. The papers contributed to the society and published in the report, whilst containing nothing of striking novelty, give much useful information. They include papers on tantalum, by Mr. F. H. Michell; on uranium ores, by Mr. F. J. Stephens; on deep bore-hole surveying, by Mr. W. R. Bawden; on modern mining methods, by Mr. J. H. Collins; and on the bees, wasps, and ants of Cornwall, by Mr. James Clark. The volume concludes with a report on the work of Falmouth Observatory, by Mr. W. L. Fox and Mr. E. Kitto.

IN the *American Journal of Mathematics*, xxix., 4, Prof. G. W. Hill shows how the attraction of a homogeneous spherical segment can be evaluated in terms of elliptic integrals.

WRITING in the *Popular Science Monthly*, lxxi., 3, under the title of "A Scientific Comedy of Errors," Profs. T. D. A. Cockerell and F. R. B. Hellems present a summary of the early history of the cochineal and allied dye-

producing insects. It contains, in particular, an account of a little-known pamphlet by Dr. Friedel (Leipzig, 1701), a man who, as the authors point out, was possessed of the true scientific spirit, but who appears to have corrected the blunders of Lcewenhoek only to make lesser blunders of his own.

THE *Rendiconto* of the Bologna Academy for 1905-6 has been recently issued. It contains papers by Prof. Guido Tizzoni and Dr. A. Bongiovanni on the curative action of radium on the virus of rabies, together with a short communication on the same subject by Prof. Ivo Novi, who seems to have arrived at somewhat different conclusions regarding the efficacy of the cure. In addition, Prof. Cesare Arzella discusses in two short notes the conditions of integrability of a series of integrable functions and of partial differential equations respectively.

FROM Captain Lyons's report of the Survey Department of Egypt in 1906, it appears that the two principal features of the work during the year were the completion of the cadastral survey (large-scale plans of the cultivable land of Egypt, on which the individual holdings are indicated), and the publication of about one-quarter of the general map of the Nile valley and the delta on the scale of 1:50,000. The work of the meteorological section has greatly increased; among many improvements we may mention that since January, 1906, monthly summaries of the weather have been prepared and published, and that subsequently the area of the Daily Weather Report has been enlarged to include pressure and wind data over the eastern Mediterranean and Nile basin, thus filling up an important gap in the regions for which weather conditions are mapped daily.

THE September part of the Journal of the Institution of Electrical Engineers contains a paper by Mr. E. W. Moss in which, under the title "Electric Valves," short accounts are given of the theory and modes of action of many of the devices used at present for converting alternating into direct currents. Of these, the Norden electrolytic valve and its modifications appear to have proved themselves most capable of dealing with heavy currents, while the glow-lamp valve of Dr. Lee de Forest and Prof. Fleming seems one of the most convenient for the small currents used in wireless telegraphy.

OUR knowledge of the electrical state of the atmosphere should in the near future receive considerable additions from the observations which, according to the June number of *Terrestrial Magnetism and Atmospheric Electricity*, are about to be taken on board the United States magnetic survey yacht *Galilee* during her cruise in the Pacific and by the staff-surgeons on board two of the vessels of the German Royal Navy. The potential gradient, the conductivity of the air, and the radio-activity of air and sea-water are all to be measured regularly during calm weather.

CRYSTALLISED alumina occurs in nature in varying shades of colour, ranging from the colourless sapphire to brown and opaque corundum. The ruby, sapphire, and oriental amethyst are varieties distinguished by their transparency and colour. These colours have been attributed to the presence of traces of salts of iron, manganese, chromium, titanium, and other metals, but the experiments described by M. F. Bordas in the current number of the *Comptes rendus* (No. 18, October 28) would appear to prove that this explanation is insufficient, since by submitting a coloured stone to the action of a highly active radium bromide the colour is modified, passing from red through

violet, blue, and green to yellow. Radium bromide of an activity of 1,800,000 was used in these experiments, the time of exposure not being stated. The action could be modified by graduating the activity of the radium salt or by increasing the distance of the stone from the radio-active material. The stones thus treated are not radio-active; they do not light up in the dark under the influence of pure radium bromide, and the coloration is permanent as regards heating.

DR. W. DOBERCK has retired from the position of director of the Hong Kong Observatory, and has been succeeded by Mr. F. G. Figg. He desires it to be known that his permanent address is now "Knowloon," Elgin Road, Sutton, Surrey.

UNDER the title of "A Chronicle of Science," the *Graphic* publishes fortnightly articles which deal attractively and accurately with topics of scientific interest. The issue of October 19 contained an illustrated description of the Percy Sladen Trust Expedition to the Indian Ocean, and the current number (November 2) includes portraits of Sir John Evans and the Rev. W. H. Egerton—the "father" of the Geological Society. Sir John Evans will celebrate his eighty-fourth birthday on November 17, and Mr. Egerton his ninety-sixth on November 13. Mr. Egerton was elected a Fellow of the Geological Society in 1832, and has therefore been on its roll for seventy-five years.

AMONG new books shortly to be issued are to be noted:—"The Functional Inertia of Living Matter," by Dr. D. Fraser Harris; "A Manual of Prescribing," by Dr. C. R. Marshall; and a revision of "Waring's Bazaar Medicines of India," by Lieut.-Colonel C. P. Lukis, I.M.S. Messrs. J. and A. Churchill will publish these three books.

A NEW edition of Mr. Wm. Woods Smyth's "The Bible in the Full Light of Modern Science" has been published by Messrs. Simpkin, Marshall and Co. Much new matter has been added. The price of the book is 1s. 6d. net.

MR. CARL ZEISS, of Jena (London address, 29 Margaret Street, W.), has published in brochure form full particulars of the field glasses he is prepared to supply. It is convenient to have in this concise form details as to price, linear magnification, and so on of these widely used glasses.

Erratum.—In Prof. Rutherford's letter in NATURE of last week (October 31, p. 661, col. 2, line 23), for "picradium" read "preradium."

OUR ASTRONOMICAL COLUMN.

COMET MELLISH (1907e).—Observations of comet 1907e made at the Lyons Observatory on October 17 showed that the object had the appearance of a diffused nebulosity of about 35" diameter, was of about the tenth magnitude, and had a slight central condensation. Observing at the Marseilles Observatory on October 17 and 18, M. Borrelly found the comet to be fairly bright and extended, with a granular appearance (*Comptes rendus*, No. 17, October 21).

Other observations are recorded in No. 4210 of the *Astronomische Nachrichten* (p. 163, October 28), in which Herrn G. van Biesbroeck reports that on October 19, using the 15-inch refractor of the Uccle Observatory with a magnification of 240, he saw the comet as a circular, nebulous object of 1' diameter and of the tenth magnitude. A central condensation, but no stellar nucleus, was seen.

Prof. Becker, director of the Strassburg Observatory,

directs our attention to the fact that the Strassburg observation of this comet, mentioned in these columns last week, was made by Dr. Wirtz.

The following is an abstract from the ephemeris published in No. 4209 of the *Astronomische Nachrichten* (p. 147, October 25) by Dr. M. Ebell:—

Ephemeris 12h. (M.T. Berlin).

1907	α (true) h. m.	δ (true) m.	Bright- ness
Nov. 4 ...	6 24.3 ...	+ 8 26.4 ...	2.7
" 8 ...	5 29.7 ...	+ 15 6.5 ...	3.0
" 12 ...	4 24.4 ...	+ 24 28.1 ...	2.8
" 16 ...	3 18.3 ...	+ 25 51.0 ...	2.3

The brightness on October 15, magnitude 9.5, is taken as unity.

From the above it will be seen that the comet is apparently travelling rapidly through Taurus, and will pass some 4° to the north of Aldebaran on November 11. On November 15 it will be less than 1° north of the Pleiades.

THE TRANSIT OF MERCURY.—Astronomers who intend to observe the approaching transit of Mercury, which will take place on November 14 in accordance with the times communicated by Dr. Downing to last week's *NATURE*, will find many interesting notes and suggestions in M. Bigourdan's articles in the *Comptes rendus* (Nos. 16 and 17) for October 14 and 21 respectively. In the former article M. Bigourdan discusses the conditions which are necessary for a transit, the results of earlier observations, and a few of the phenomena which it is advisable to observe. For example, he suggests that an attempt to repeat Langley's observation of Mercury before the first contact in 1878 might be made. In the same year Janssen, using a spectroscope, was able to see the planet projected on a bright prominence before contact with the sun's limb, but this is an unlikely observation at the coming transit, because the contacts take place near the north pole of the sun, where prominences are fewer.

In the second article M. Bigourdan deals with other points of interest, such as the exact measurement of the distances between the edge of the planet and the sun's limbs in order to determine more exactly the times of the contacts, the form of Mercury's disc as seen on the sun, and the possible observation of satellites, which, if they existed, might be seen projected on the bright solar disc; the determination of the planet's diameter and the effects of different apertures in such observations are also discussed. As Mercury will be seen on the sun's disc at mid-day in Europe, its exact position on the disc may be determined with meridian instruments. M. Bigourdan then discusses the previous observations of both bright and dark rings surrounding the disc of Mercury, and suggests that a spectroscopic examination might reveal special absorption lines, the existence of which would prove the reality of the annuli, and hence the existence of an atmosphere belonging to the planet. Observations of bright points and spots on the planet's disc have been frequently reported during previous transits, but the real existence of such phenomena still requires further confirmation. M. Bigourdan's second paper concludes with a discussion of the methods of observation and the class of instruments it is advisable to employ.

CHANGES ON SATURN'S RINGS.—A telegram, dated October 28, transmitted by Prof. Pickering to the Kiel Centralstelle, announces that Prof. Campbell observed prominent bright knots, visible during the past week, in Saturn's rings. The knots were symmetrically placed, two being to the east and two to the west (Kiel Circular, No. 101, October 28).

A BRIGHT METEOR.—Mr. Arthur Mee reports that a magnificent meteor was seen by observers at Cardiff and Newport on the evening of October 31. It appeared at exactly 10 o'clock, and fell leisurely from γ Cygni to a point just west of Vega. The head "opened out like a rocket," leaving a train that remained visible for several seconds. Those who saw it are not quite agreed as to the colour of the head, but all testify to its great brilliancy, though the night was by no means a dark one.

THE NEW MUNICIPAL TECHNICAL INSTITUTE, BELFAST.

THE formal opening of the new Municipal Technical Institute, Belfast, on October 30, by the Lord Lieutenant of Ireland (the Earl of Aberdeen), may be said to close the first epoch in the history of technical education in that city, and, indeed, in the whole of Ireland. When it is remembered that the Agriculture and Technical Instruction (Ireland) Act became law so recently as 1899, the progress already made is most noteworthy. Within that brief period the annual enrolment of students has risen to 5000, and these are now housed in a building which in beauty of architecture and excellence of equipment may challenge comparison with anything of a similar nature in the United Kingdom.

In the year 1900 the Corporation of Belfast decided to put the Act in force, and appointed a strong committee to carry on the work. The committee chose as its chairman Alderman Sir James Henderson. A happier selection or one more fruitful of good results it is difficult to imagine. A former Dublin University man, a member of the Irish bar, a past Lord Mayor of the City, and the managing director of an old and influential newspaper (the *Belfast News-Letter*), Sir James was admirably fitted to take up the duties of pioneer of technical education in his native city and province. Operations on the site were commenced in February, 1902, but, owing to the peculiar nature of the subsoil, great care was requisite in the formation of a suitable foundation. The site itself is 240 feet by 205 feet in size, and into this area were driven 2750 piles, each 40 feet in length. The heads of these piles were connected to longitudinal timbers, and the whole bonded together in concrete. The formal laying of the foundation-stone was performed on November 24, 1902, by the Earl of Dudley, at that time Lord Lieutenant of Ireland.

A general idea of the external architectural design of the building will be readily grasped from the accompanying reproduction from a photograph; and it will be sufficient to state here that the height of the top of the surmounting balustrade above the pavement is 85 feet; to the top of the domed towers the height is 135 feet. Internally, the building surrounds two courtyards, these courtyards being lined with white glazed bricks and roofed in with glass over the ground floor. The corridors are carried round these areas, and are spacious and well lighted. The floors throughout are of steel and concrete, finished in the laboratories and class-rooms with solid wood blocks, and in the corridors and lavatories with marble terrazzo. Ample gas and water supplies are laid on everywhere, and the building is lighted throughout by electricity. Heating and ventilation are provided by the "Plenum" system. The air, after being washed and screened, enters the heating chamber, where it is passed over tempering coils, and is finally driven throughout the building by a large pair of "Ulster" centrifugal fans. The capacity of these fans is 140,000 cubic feet of air per minute. Arrangements are also made for driving these fans by electricity when heat is not required.

Coming to the question of departmental arrangement, the general idea has been to group together the work of each department in one suite of rooms. The subjects taught are grouped into departments as follows:—mathematics, mechanical engineering, naval architecture, physics and electrical engineering, building trades, textiles, pure and applied chemistry, miscellaneous industries, natural science, commerce, domestic economy, and art.

The department of mechanical engineering includes a total area of 13,000 square feet. On one floor are the lecture rooms, drawing rooms, a photo-printing room, and a mechanical laboratory in which fifty students can work at the same time. The engineering laboratory, workshops, and boiler house are on another floor. The mechanical laboratory is fitted with a large range of appliances of small type all of the newest description. The central idea in providing the equipment has been to keep the application of mechanics to engineering well to the front. A small hydraulics section is attached to this laboratory. The floor of the engineering laboratory is double, and in the intervening space are stored all shafts,

belts, pipes, and also the arrangements not directly required for experimental work, thus leaving the floor clear from obstruction. Beneath the lower floor a tank of ten thousand gallons capacity has been built. A wide range of machinery has been installed. The department also comprises a machine shop and a pattern shop.

In the lecture rooms and laboratories of the department of physics and electrical engineering the machinery is of the latest type. Everything has been provided for giving a complete training, theoretical and practical, to the students.

As is to be expected in a city like Belfast, particular attention has been paid to the equipment of the department of textile manufactures, and the result has been to make the new institute almost unique in this respect. Particular emphasis has naturally been laid on the various

facts and statistical data, and a historical retrospect of technical instruction in Belfast, whilst the book is finely illustrated with internal and external views of the institute. The book is to be sold at 1s., or by post 1s. 3d. Copies can be obtained on application to the institute.

LONDON DAY TRAINING COLLEGE FOR TEACHERS.

IN June, 1901, in response to urgent representations from the School Board for London and other important bodies, the late Technical Education Board of the London County Council secured the adoption of a scheme under which the Council undertook to provide and maintain a day training college for men and women



The Municipal Technical Institute, Belfast.

flax products, and in this connection a very complete range of machines has been installed.

It is unnecessary to examine in detail the equipment of the remaining departments. In every case the expenditure has been equally generous, and the results equally satisfactory. Special mention may be made of the art school, which occupies the entire top storey, and now ranks as one of the best schools in the kingdom. The chemical laboratory is the largest room in the institute, and has been furnished on a complete scale.

Belfast may well be proud of its new institute. Facilities are now provided for the carrying on of the work of technical education such as cannot fail in the immediate future to have an important and beneficial influence on its trade and industries.

In connection with the opening ceremony, a "Souvenir" book has been issued. This contains a number of portraits, views of the institute, a chronological table, salient

teachers in close connection with the newly re-constructed University of London, and a chair of education in the University to be held by the principal of the college.

Work was commenced in October, 1902, under the direction of Prof. John Adams, and has been continued in various temporary premises until the present term, when the college entered into possession of the southern half of the fine block of buildings designed by the Council's architect (Mr. W. E. Riley) to fill a site recently cleared at the Holborn end of Southampton Row. (The northern half of this block will, when finished, be occupied by the L.C.C. Central School of Arts and Crafts.) The celebration of the entrance of the college into its permanent home was the motive of an interesting ceremony conducted by the chairman of the Council (Mr. Percy Harris) on Saturday last, when Lord Rosebery, as Chancellor of the University, formally declared the building open.

The majority of the students of the college are "recog-

nised students" (formerly "King's scholars"), receiving a grant from the Board of Education, who have matriculated, and are thus qualified to enter one of the schools of the University for a three years' course, leading up to the degree in arts or science. Concurrently with their academic studies they take a course of professional instruction at the training college with a view to certification by the Board. In addition to these students, there is a smaller number of graduates who take a one year's course in preparation for the University's diploma in pedagogy, and intend to teach in secondary schools. Since, however, a rapidly increasing proportion of the recognised students enter with a higher qualification than matriculation, and obtain the degree before the conclusion of the three years' course, the work of the college will in a few years become very largely post-graduate, and may be expected to have an important influence upon the standard of teaching in the elementary schools of London.

Since every student is either a graduate or an internal student of the University in arts or science, the equipment of the college has been determined solely by the needs of the professional side of the course of training. Thus the laboratories, which together with the art studio occupy the top floor of the building, are used almost entirely for the demonstration of methods of teaching science subjects. The larger laboratory (55 feet by 30 feet) contains benches of a special design planned for elementary work in chemistry, physics, and mechanics, fume cupboards, a well-equipped demonstration table, and teak tables used chiefly in connection with the instruction in practical mathematics. Between the mathematical and physical benches accommodation is provided for students following the course of a lesson given to a class of children.

The smaller laboratory (30 feet by 20 feet) is devoted to nature-study. In addition to working benches, it is equipped with specimen cases, a dark cupboard, and other fittings. A balance room and a preparation room situated between the two laboratories serve the needs of both. There is also a small room (readily transformable into a photographic dark room) equipped with water, gas, and electric power, and intended to be used for anthropometric work and for researches in pedagogical psychology.

On the roof, within easy access from the laboratories, is a plant house containing a large tank for aquatic plants and animals. The level space around this is utilised as a meteorological observatory in connection with lessons in geography. Finally, on the floor below that already described, is a pedagogical museum, which performs the functions of a geographical laboratory.

Carefully planned and closely correlated courses in mathematics, geography, nature-study, and physical science are taught in these laboratories to the children of the demonstration schools by students under supervision. Most of these students either have already graduated or are about to sit for the B.Sc. degree, and are paying special attention during their last year to the teaching of the scientific subjects of the curriculum.

IMMUNITY TO DISEASE AMONG PLANTS.¹

THE question of immunity to disease has been so closely studied and so frequently discussed in connection with the diseases of man that it seemed to me that it might be of interest to bring together some of the facts now known to us about the incidence of disease among plants and the theories which have been advanced as to the cause of the immunity which some species and varieties exhibit to various diseases.

The late Prof. Marshall Ward has shown that *Puccinia dispersa*, the brown rust of grasses, seems to exist in several "biologic forms," each of which attacks only one group of nearly related species of Bromus, and the same condition obtains in the Erisipheæ, or mildews, according to Salmon. How is it that these fungi are incapable of infecting such nearly related host plants as are represented by the species within a single genus? The suggestion was originally made that differences in the thickness of the cell walls, fewer or smaller stomata,

longer hairs, &c., were the obstacles which repelled the fungi and rendered certain species and genera of plants immune to the attacks of particular fungi. Working with the different species of Brome, Marshall Ward was, however, able to show that there was no relationship between the stomata, hairs, and so forth, and the infectibility of the species. Immunity did not in any way depend upon the anatomical characters of the host plant, but entirely on physiological reactions of the protoplasm of the fungus and of the cells of the host. In other words, infection and resistance to infection depend on the power of the fungus protoplasm to overcome the resistance of the cells of the host by means of enzymes or toxins, and reciprocally on the protoplasm of the cells of the host to form anti-bodies which destroy such enzymes or toxins, just as is the case with resistance of animal organisms to their bacterial foes. Salmon has shown in his experiments that susceptibility in a leaf normally immune to the attacks of the biologic form of a particular mildew may be induced by various mechanical means, such as cutting the leaf or searing it with a red-hot point of a knife, or by exposing the leaf to ether or alcohol vapours, or by exposing it to heat. The resistant vitality is thereby impaired, and the fungus gains the upper hand. Plants, if not immune to a particular disease, may be rendered so to a certain extent by similar methods to those employed in the case of animals. More or less successful injection experiments have been made in the case of fruit trees suffering from chlorosis, and as a result animal parasites have been got rid of as well. Undoubtedly if the general vitality of the tree can be raised some diseases can be thrown off.

Marchal has stated, 1902, that young plants of the lettuce could be rendered immune against *Bremia laticuca* by feeding the plants with a solution of copper sulphate (1 in 30,000). This view has received support from Laurent and Massé, but Salmon has not been able to confirm these results. It will be seen that the views are still somewhat conflicting, and too much must not be expected from such methods of treatment.

The hope of the agriculturist lies in another direction. Plants, like animals, are subject, as Darwin has shown, to a considerable amount of variation, and all characters, whether anatomical or physiological, are subject to change or mutation. Immunity to disease, dependent as it is on certain physiological peculiarities, the secretion of anti-toxins, rather than on anatomical structure, is similarly a subject of variation. We see this readily illustrated when passing through a field exposed to some epidemic disease, where here and there plants are found which have been either only slightly damaged or not attacked at all. These should be selected for breeding purposes, and thus hardier varieties can be produced. Another method which has shown itself useful for producing resistant forms is by hybridising. It is a well-known fact that hybrids, while partaking of the nature of one or both of the parents in most characters, generally exceed both in vegetative vigour—a characteristic to which the sterility of some hybrids is attributed. But vegetative vigour, as we have seen above, is generally associated with immunity to disease, and hence hybrids are often found to be more resistant. This is not always the case, for in this respect hybrids vary too, but the French horticulturists MM. Bouettes and Guillon have been successful in producing hybrid vines which are more resistant to the mildew than either of the parents.

In the selection of immune varieties one is faced with the unfortunate fact that many of the most resistant forms are the least valuable, producing poorer fruits and seeds than the delicate forms. But by judicious hybridising this defect of the immune race can be largely counteracted. Mr. Lewton Brain has collected a good deal of information on this point. Both in the case of vines and in wheat many disease-resisting forms have been produced.

In connection with cotton crops, it is remarkable how great is the range of variation with regard to the resistance of the plants to the wilt disease (*Neocosmospora vasinfecta*). By selection and suitable hybridising, Rivers has been able to obtain varieties which remained untouched by the disease, while of the neighbouring crops

¹ Abridged from an address delivered at the annual meeting of the British Pharmaceutical Conference at Manchester by Prof. F. E. Weiss.

95 per cent. were destroyed. In the West Indies the Bourbon cane has been given up on account of disease, but very useful and disease-resisting hybrids have been produced by crossing the valuable but easily attacked Tjeribon cane with the resistant Indian Tschan cane.

It will thus be seen that breeders have the power by careful selection to combine disease-resisting powers with relatively great fertility, and therein lies our hope for the future success of agriculture.

THE BED OF THE WESTERN PACIFIC OCEAN.

THE results of surveys carried out by the surveying vessel *Edi* and the cable-ship *Stephan* during 1903 and 1905 in the western and south-western parts of the Pacific Ocean have been published in a paper by Drs. G. Schott and P. Perlewitz, recently issued in the *Archiv der deutschen Seewarte*. An abstract by Dr. Schott appears in the *Annalen der Hydrographie* (1907, p. 108). Taken in conjunction with the work of the American vessel *Nero* (already noticed in these columns) and of the German vessel *S.M.S. Planet* (see *Annalen der Hydrographie*, 1907, pp. 49 and 50, 193 and 194, and 196), these soundings throw a great deal of new light on the configuration of the sea bottom in those regions, disclosing certain characteristic features of great interest in their bearing on the history of the Pacific Ocean and its extension westward at the expense of the Asiatic continent, and also on the general problem of the form of the surface of the lithosphere.

The typical form may be described thus. Along a line running seaward from the coast of Asia the depth is (beyond the continental shelf) about 3000 metres; it diminishes slowly and fairly uniformly at first, then rapidly, until the surface is reached on a cross-line of islands. To seaward of the islands the bottom falls first slowly and then very steeply to a line of "deeps," in which depths of 7000 metres to 9000 metres are reached; then follows a fairly gradual rise to a "Horst" some 4000 metres below the surface. These structures, so far as appears from these observations, occur (1) in the Liu-Kiu Islands and deep; (2) in the Tular Islands and deep; and (3) in a line following the Pelew Islands, Yap, Guam, and the eastern Ladrones. The soundings of the *Planet* show that the "Tular" deep (2) is continuous with a long, narrow trough extending northward along the east coast of the Philippines, and it seems not unlikely that the "Liu-Kiu" deep (1) is part of the same depression. The "Guam" deep is identical with the "Caroline" deep discovered by Friederichsen in 1901.

The troughs forming the deeps are usually about ten miles wide (the Guam deep is as much as twenty miles across), and Drs. Schott and Perlewitz are of opinion that they are the result of subsidence occurring on an enormous scale along lines of fracture. It is probable that the disturbances which produced these structures are comparatively recent; geological relations suggest Tertiary times, at least in the case of the Liu-Kiu deep, and there is obviously nothing in the suggestion incompatible with the great antiquity of the Pacific basin as a whole.

HYDROLOGY IN EGYPT.

THE Rains of the Nile Basin and the Nile Flood of 1906" is the first of a new series of periodical reports which are being published by the Survey Department of Egypt. These departmental papers are intended to comprise results of technical or scientific interest which are obtained in the course of the work of the department.

Captain H. G. Lyons, the director, says that although the increase of rainfall stations in British Central Africa, Uganda, and the Sudan has materially reduced the difficulty of forecasting the flood, the absence of any definite information as to the meteorological conditions of Abyssinia, especially during the rainy season, June to August, is a great drawback, and to overcome this somewhat he intended early in 1907 to send a qualified meteorologist to Addis Abbaba to study the local conditions.

The chapter on the normal distribution of rainfall traces the heavy rains from Zomba and British Central Africa and German East Africa in January and February to Abyssinia and the Sudan in July and August. During these two months these countries receive 60 per cent. of their annual rainfall. In September the rain begins to moderate in Abyssinia, and to retreat southwards.

In discussing the rainfall for 1906, it is shown that most places in the districts under observation had excess rain at the period of normally heavy rains, whilst in their respective dry seasons there was deficiency. In the Nile Basin the rains were somewhat late in commencing.

At the end of October, 1905, it seemed likely that during 1906 the Nile would be low, for the summer rains in Abyssinia had been weak. In November, February, and March some exceptional and heavy rains improved matters, and gave a fairly good supply of water.

At Khartoum the flood commenced on May 27, sixteen days late, and reached its maximum on September 14, ten days late. The volume of the flood estimated from the discharge curve of the Aswan gauge during July, August, September, and October was 0.87 of the mean of thirty-eight years.

During April, 1906, Mr. J. I. Craig made an investigation to determine the amount of seepage through the banks of the river. Using the records of flow at Aswan and Sarras, and special observations of flow made at Kareima, Mr. Craig came to the conclusion that at the period of low water, and on that stretch of the river between Khartoum and Sarras, a distance of 1480 kilometres, water flowed through the banks into the river at the rate of between 140 and 200 cubic metres per second. During the flood water passes out of the river similarly, for then the level of the water-table in the surrounding country is lower than the surface of the river.

UNIVERSITY AND EDUCATIONAL INTELLIGENCE.

CAMBRIDGE.—The Sites Syndicate has had under consideration the most suitable position for the proposed buildings in connection with the school of agriculture. It is of opinion that the most suitable position would be one on the Downing site, to the south of the botany school and parallel with it. The building on this site would be near the departments of botany and geology, and would be accessible from three roads, and it would be well lighted. At the present time the department of agriculture is housed in the basement of the chemical laboratory, but in view of the greatly increasing number of students in agriculture proper provision of laboratories, lecture-room, and museums is urgently needed. Towards the cost of an agricultural school some 13,000*l.* has already been subscribed by friends of agriculture and the University. A suitable building would probably cost some 20,000*l.*, and it is further desirable that some provision should be made for maintenance.

Mr. A. E. Shipley has been nominated a manager of the Frederick James Quick fund from January 1, 1908, to December 31, 1913.

The following have been nominated examiners for the Natural Sciences Tripos in 1908:—*Physics*, Mr. J. A. McClelland and Mr. P. V. Bevan; *chemistry*, Dr. Fenton and Mr. K. J. P. Orton; *mineralogy*, Mr. A. Hutchinson and Mr. L. J. Spencer; *human anatomy*, Mr. T. Manners-Smith and Prof. R. Howden; *geology*, Mr. E. J. Garwood and Mr. W. G. Fearnside; *botany*, Mr. F. W. Oliver and Mr. F. F. Blackman; *zoology*, Dr. Harmer and Mr. R. C. Punnett; *physiology*, Mr. F. G. Hopkins and Dr. M. S. Pembrey.

OXFORD.—The preamble of a statute establishing a professorship of engineering science was passed by Congress on October 29 by a majority of 152 to 20.

The Burdett-Coutts scholarship in geology has been awarded to R. L. Robinson, Magdalen College; C. H. Dinham, Magdalen College, distinguished himself in the examination.

LORD AVEBURY has been elected without opposition Lord Rector of the University of St. Andrews.

According to the *Pioneer Mail*, one lakh of rupees has been added to the Griffith bequest to found a university library attached to the Madras University, and another sum of sixty thousand rupees for university lectureships and research scholarships.

At a recent meeting of the Senate of the University of London, the following resolution was unanimously adopted:—"That the Senate have received with sincere regret the announcement by Sir Arthur Rucker that he wishes to relinquish office on September 30, 1908, and record their appreciation of the great services he has loyally rendered to the University as principal since its re-constitution."

The graduate school of applied science at Harvard University recently received the gift of about 2000 acres of valuable timber land as a special adjunct to its instruction in forestry. According to Prof. R. T. Fisher, the forest included in this gift comprises the best body of timber now to be found on an equal area in Massachusetts. Its special advantage is in the arrangement of the age-groups or generations of timber. It so happens that stands of various ages, from the small sapling to the mature tree, are almost equally represented in separate sections of the forest.

The annual prize distribution and conversazione of the Northampton Polytechnic Institute, Clerkenwell, E.C., will be held on Friday and Saturday, November 29 and 30. The Duke of Connaught has consented to distribute the prizes on November 29, and after the prize distribution the whole of the laboratories, workshops, drawing office, and studios of the institute, both in the main building and in the British Horological Institute adjoining (the technical optics department), will be on view in working order. The conversazione of members and students will be held on the following evening.

The Board of Education, South Kensington, has issued the following list of candidates successful in this year's competition for the Whitworth scholarships and exhibitions:—(1) Scholarships, 125*l.* a year each, tenable for three years: A. A. Rowse, London; N. J. Perryman, Portsmouth; G. Hudson, Portsmouth; J. Warren, Portsmouth. (2) Exhibitions, 50*l.* a year each, tenable for one year: A. W. Judge, Portsmouth; J. H. Hyde, Leytonstone; E. A. Steed, Devonport; A. J. Begg, Plumstead; M. R. Dewhurst, London; R. D. Given, Edinburgh; F. A. Bumpus, Birmingham; R. J. Iliffe, Liverpool; S. L. Symms, London; F. Morris, Portsmouth; W. P. Johnson, Kelsall Hill, Chester; T. W. Johnson, Neyland; J. H. Neal, Devonport; H. Mawson, Hunstley, Leeds; E. W. Stedman, Sheerness; F. Morrison, Aberdeen; R. G. Milner, Plumstead; A. Hutchinson, Glasgow; H. J. Middleton, Forest Gate; A. T. Phillips, Barking, Essex; W. Macgregor, Greenock; M. J. C. McCarthy, Sheerness; H. T. Wright, London; A. McFadyen, Lasswade, Midlothian; F. G. Rendell, Portsmouth; J. H. Blythe, Devonport; F. C. D. Mann, Hayes, Kent; J. E. Collyer, South Woolwich; B. Baker, Southsea; L. C. Brown, Wolverton.

MR. ASQUITH, Chancellor of the Exchequer, visited Aberystwyth on November 1 to open the Edward Davies chemical laboratories, the gift of Mr. David Davies, M.P., and his mother and sisters, to the University College of Wales, Aberystwyth. The new buildings have been erected at a cost of 25,000*l.* In the course of a speech at a great public meeting held subsequently, Mr. Asquith said Aberystwyth has owed little, at all events, until that day to the munificence of the man of wealth, and there are very few other institutions, either in England or in Wales, of which it can be said that it was brought into being and that for many years it was kept in being by the pence of the Welsh people. There are few more interesting or encouraging chapters in the history of democracy than that which recounts what in our time the Welsh people has done for education. In the course of thirty years something very near 120,000*l.* has been subscribed for the purposes of the college, Aberystwyth, and the remarkable feature is that it has been subscribed by 100,000 separate donors. The figures no doubt are equally striking at Bangor and Cardiff. The university system in Wales has been undertaken by the people for the people. During

the same period there has been voluntarily subscribed to set on foot a system of intermediate schools something approaching the same sum—50,000*l.* to 100,000*l.* There is still much work to be done, many gaps to be filled; but the Welsh people formed their intermediate system first of all, and now, by the founding of their university colleges, any Welsh child of brains, zeal, and good character, whatever the social surroundings of its parentage, can climb without undue favour or assistance to the very highest position in the pursuits of industry or commerce.

SOCIETIES AND ACADEMIES.

LONDON.

Royal Society, June 27.—"Note on the Use of the Radiometer in observing Small Gas Pressures; Application to the Detection of the Gaseous Products produced by Radio-active Bodies." By Sir James Dewar, F.R.S.

The experiments described in this paper seem to show that the radiometer may be used as an efficient instrument of research for the detection of small gas pressures and the study of radio-active products. For quantitative measurements the torsion balance or bifilar suspension must be employed. It would be interesting to repeat light repulsion experiments in the highest attainable charcoal vacuum. The author hopes to extend the investigation later.

Entomological Society, October 16.—Mr. C. O. Waterhouse, president, in the chair.—*Exhibits.*—A. H. Jones: A series of *Pieris napi*, var. *bryoniae*, from comparatively low altitudes near Budapest, showing a wide range of variation, and a remarkable aberration of *P. napi* (*nabacae*) bearing a strong resemblance on the underside to *P. rapae*.—M. Burr: An example of *Apterygida albipennis*, discovered by him near Dover this year; and a ♂ specimen of *D. verrucosus*, an inhabitant of Scandinavia, from the same locality.—H. Campion: *Platyleis roeselii*, Hagenb., ♀, taken September 13 near Herne Bay, which there are but few well-authenticated British specimens.—E. W. Campion: An aberrant specimen of *S. sanguineum*, ♂, from Epping Forest, suggesting relationship with certain Orthoptera, and two *Calopteryx virgo* of his own from the New Forest showing failure in pigment.—W. J. Kaye: Specimens of *Callicore aurelia*, Guen., together with a photograph of its larva, showing the remarkable branch-like horns rising out of the head.—Rev. F. D. Morice: A normal ♂ specimen of the bee *Athidium manicatum*, L. (the "hoop-shaver bee" of Gilbert White's "Natural History of Selborne"), and a monstrosity or malformation of the same insect from Argentat, Corrèze, France.—C. O. Waterhouse: (1) A living ant, a species of *Camponotus*, found by Mr. Watson at Kew, in the pseudobulb of an orchis (probably a *Bulbophyllum*) from the Gold Coast. The bulb was much excavated, but it had no opening by which the ant could have entered; (2) a large wasp (a *Salix* allied to *dexias*) with a spider, a Mygalae rather larger than itself, but which it had captured and was carrying off.—Lieut.-Colonel Neville Manders: A melanic variety of *Hestia nama*, captured near Darjeeling, and a monstrosity of *Papilio krishna*, from Sikkim, in which the wings on the right side were much larger than those on the left.—H. Main: The larva of a hymenopterous parasite of *Pygaera bucephala*, of great size comparatively to its host.

Institution of Mining and Metallurgy, October 17.—Prof. William Gowland, president, in the chair.—The origin of the gold in the Rand banket: Prof. J. W. Gregory. A carefully reasoned argument in favour of the marine placer theory, as opposed to the infiltration theory. The author quoted the leading authorities both for and against his own conclusions, which are based on a personal visit to the Rand and a subsequent weighing of all available evidence. After a brief historical introduction, the paper was subdivided under the following heads:—theories of the genesis of the Rand gold; the rocks of the Rand goldfield; the arguments against the placer theory; evidence against the infiltration theory; evidence of the microscopic structure of the rocks; com-

parison with other goldfields; economic bearing of the problem; and, finally, summary of conclusions. The author stated that in his opinion the theory as to the origin of the blanket in best agreement with the facts appeared to be that which regarded the blanket as a marine placer in which gold and black sand (magnetite with some titaniferous iron) were laid down in a series of shore deposits. Owing to the late hour at which the discussion on this paper terminated, the other paper on the evening's agenda, the deviation of Rand boreholes from the vertical, by Mr. Joseph Kitchin, was held over for discussion at the meeting on November 21.

MANCHESTER.

Literary and Philosophical Society, October 1.—Prof. H. B. Dixon, F.R.S., president, in the chair.—The president delivered an inaugural address, in which he referred shortly to the work on radio-activity, with which is intimately associated the name of Prof. E. Rutherford; the work of Messrs. Barlow and Pope, by which the valency of the chemical atom has been connected in a definite manner with its volume in crystalline structures; the researches of Prof. Perkin on the formation and stability of various carbon rings, more particularly his work on the camphor and terpene series, and at somewhat greater length on the work in which he was most interested personally—the propagation of the explosion wave in gases, the direct determination of the specific heat of CO₂, the temperature of the ignition points of gases, and the re-determination of the atomic weight of chlorine.

October 15.—Prof. H. B. Dixon, F.R.S., president, in the chair.—The relation between the crystalline form and the chemical constitution of simple inorganic substances: Prof. W. J. Pope and W. Barlow. The authors have applied the methods employed in their paper of October 16, 1906, to the study of the crystalline structure and molecular condition of a number of simple inorganic substances, such as the crystalline elements, binary compounds like silver iodide, potassium chloride, &c., ammonium halogen salts and compounds of the type of rubidium tri-iodide, RbI₃.

PARIS.

Academy of Sciences, October 28.—M. H. Becquerel in the chair.—The disease of the pine in the Jura: MM. Prillieux and Maublanc. The disease of the pines in the Jura, recently pointed out by M. Bouvier and called by him *rouge*, has been studied in Germany by Hartig, who has shown that the disease is due to the attack of a parasitic fungus, *Phoma abietina*. The same fungus, for which the authors prefer the name *Fusicoccum abietinum*, attacks the pines in the Vosges and the Jura. The disease is not so grave as has been supposed by M. Bouvier, as the trees are rarely killed by it, certain of the branches only being attacked. The rational treatment is the removal of the dead branches and their destruction by incineration; in this way the fructification of the fungus and the dissemination of its spores are avoided; but this treatment may be too costly, and not justified by the actual losses threatened.—The heat of formation of the oxides of lithium: M. de Forcrand. A criticism of the data put forward by various authors for the heat of formation of Li₂O, together with experimental data for the heat of formation of LiOH and Li₂O₂.—Observations of the comet 1907e (Mellish) made at the Observatory of Besançon with the bent equatorial: P. Chofardet. Apparent positions of the comet, and position of the comparison star for the night of October 17. The comet was of the ninth magnitude, of circular form, without a distinct nucleus. Total diameter about 2'.—Observations of the comet 1907e made at the Observatory of Algiers with the 31.8 cm. bent equatorial: MM. Sy and Villatte. Similar sets of observations for October 18 and 20.—Critical transcendental points and inverse functions of integral functions: Pierre Boutroux.—Contribution to the synthesis of precious stones of the family of the aluminides: F. Bordas (see p. 17).—A new quantitative measuring instrument for the X-rays: H. Guilleminot.—Some iodomercurates: A. Duboin. The following double iodides have been isolated in a crystalline form and analysed:— $\text{Fe}_{1,2}\text{Hg}_{1,1}\text{I}_2\text{H}_2\text{O}$; $\text{Hg}_2\text{O}_2\text{AlI}_3\text{HgI}_{1,15}\text{H}_2\text{O}$; and $\text{2AlI}_3\text{5AgI}_2\text{2AgO}_2\text{13H}_2\text{O}$.

—A new method of determining the atomic weights of precision simultaneously for all the elements present in a single chemical reaction: G. D. Hinrichs. The author describes a graphical method of reduction to the experimental data for silver, chlorine, thallium, nitrogen, oxygen, and radium, with the result that all the atomic weights are reduced to multiples of 0.5.—A colloidal solution of arsenious anhydride reduced by hypophosphorous acid at a low temperature in presence of a large amount of alcohol gives a reddish-brown powder, consisting of metallic arsenic, 68.2 per cent.; phosphorus, 0.97 per cent.; alcohol, 2.5 per cent.; and water, 28.4 per cent. This form of arsenic possesses the property of dissolving immediately in a dilute solution of caustic soda, giving a brown colloidal solution, the properties of which are given in detail.—Some causes of error in the estimation of phosphorus in iron, cast iron, and steel: G. Chesneau.—The formation of liquid crystals of two new compounds of cholesterol: Paul Gaubert. The two compounds are obtained by heating cholesterol with glycollic acid or with glycerol.—The disease of the pine in the forests of the Jura: E. Henry. This disease was first observed in the summer of 1906, and up to the present has not caused the death of a single tree.—A new method of reaction of the skin to tuberculosis, and its utilisation in the diagnosis of tuberculosis: J. Lignières. A development of the Pirquet reaction in which the tuberculin may be replaced by dead tubercle bacilli. The skin need not be broken, as it is sufficient to rub the dead bacilli or pure tuberculin in until the skin is well reddened. Healthy animals give no specific reaction but with tuberculous animals there is a well-marked reaction.—The explanation of the general mechanism of the transformation of glycogen into glucose by the muscles and the animal tissues: F. Maignon. The author concludes from his experiments that the muscles possess an amylase capable of effecting the transformation of glycogen into glucose.—The transparency and colour of sea water in the English Channel: M. Letalle.

NEW SOUTH WALES.

Royal Society, August 7.—Mr. H. A. Lenchan, vice-president, in the chair.—Note on copper in andesite from near Lautoka, Fiji: H. I. Jensen. This paper describes the occurrence of lumps of copper ore weighing from 1 lb. in andesitic matrix. An analysis of a specimen showed that it contained 53½ per cent. Cu, 7½ per cent. Fe, and 21½ per cent. S, the metallic portion being therefore a mixture of bornite and chalcocite. A microscopic examination confirmed the presence of these two minerals. The same minerals were found to occur in many of the normal andesites of the district in smaller quantity. A quantitative estimation revealed 0.034 per cent. of CuO in the normal andesite. It appears from the examination of specimens obtained that either copper ore has segregated out in the consolidation of the lava, or else, in the period of consolidation, magmatic vapours have extracted the copper from portions of the lava and deposited it elsewhere in the mass. The copper distinctly belongs to the andesite magma of the district, and does not constitute a mere xenogenic included product. It is interesting to note that such a differentiation has there taken place in a true volcanic rock.—Analysis of a specimen of sea-water from Coogee, New South Wales: C. J. White. Special attention was paid to the specific gravity determinations (for the calculation of which Buchanan's hydrometer No. 6 was used), for this gives the salinity directly, and indirectly gives very valuable indications of the various constituents present (the ratio of dissolved salts to one another being practically constant for all ocean waters).—Notes on some aboriginal tribes: R. H. Mathews.—Note on the action of lime on the available soil constituents: F. B. Guthrie and L. Cohen. The authors have investigated the changes that take place in the amounts of water-soluble and citric-soluble potash and phosphoric acid in limed soils in pots. Three kinds of soil were used, sand, garden loam, and clay. They find that in all cases the amount of mineral plant-food soluble in water had diminished to a considerable extent in the unlimed pots after standing for a month. The effect of liming has been to lessen this loss, but it does not appear to prevent it entirely. There is less water-

soluble plant-food in the limed soils after a month than in the original soils, but more than in the untreated soils after a month. The action of lime is largely to increase the amount of nitrogen as nitrites; the nitrate-nitrogen is almost the same in the limed and the unlimed soils, except with the clay soil, where the nitrates are diminished. The total nitrogen as nitrite and nitrate is increased by liming, and the action of lime would appear to be to favour the development of the nitrous organism in particular.

September 4.—Mr. H. A. Lenehan, vice-president, in the chair.—The one-wheeled car: L. Hargrave. The paper points out the adaptability of the gyro-engine, a combination of the gyroscope and revolving cylinder engine, for balancing and driving all sorts of vehicles on one wheel over country that would otherwise be impracticable.—The steady deflection method of current measurement with an electrometer: Prof. J. A. Poilcock. The steady deflection method of measuring currents with an electrometer consists in arranging that the charge on the ordinarily insulated quadrants shall leak to earth at a suitable rate proportional to the potential difference between the two pairs of quadrants. In the paper two ways which have been proposed for carrying out the method are mentioned and discussed.

DIARY OF SOCIETIES.

THURSDAY, NOVEMBER 7.

ROYAL SOCIETY, at 8.30.—The Effect of Pressure upon the Arc Spectra of Metals: W. Geoffrey Duffield.—The Electric Discharge in Monatomic Gases: F. Soddy and T. D. MacKenzie.—The Diurnal Variation of Terrestrial Magnetism: Prof. A. Schuster, F.R.S.—On the Measurement of Temperatures in the Cylinder of a Gas Engine: Prof. H. L. Callendar, F.R.S., and Prof. W. E. Dally.—Note on the Association of Helium and Thorium in Minerals: Hon. R. J. Strutt, F.R.S.—Further Results of the Experimental Treatment of Trypanosomiasis in Rats (Progress Report of Sleeping Sickness Committee of the Royal Society): J. H. G. Plimmer and J. D. Thomson.

ROYAL SOCIETY, at 8.15.—The Presidential Address, The Production of High Frequency Oscillations, with Demonstrations: W. Duddell, F.R.S.

LINNEAN SOCIETY, at 8.—The Origin of the Di-trimerous Whorls among the Flowers of *Linnaea*: George Henslow.—Unrecorded Acari from New Zealand: Albert D. Michener.—On *Exochus* *sp. africanus*, a new Genus and Species of Diptera: R. Shelford.—*Exhibits*—A copy of Hudson's "Flora Angra" 1778, with numerous annotations by the Rev. William Kirby; Alexander Stevenson.—Abnormal Stem of *Eucalyptus globulus*: F. Muel, from Dr. A. C. Rendell.

CHEMICAL SOCIETY, at 8.30.—Gaseous Nitrogen Trioxide: H. B. Baker and Mrs. M. Baker.—The Atomic Weight of Tellurium: H. B. Baker and A. H. Bennett.—The Isomerism of the Double Sulphides of Sodium and Potassium: M. H. Guppy.—Studies in the Amphane Series, Part xxiv, Camphorylidicacetic Acid, and Camphorylidicacetic Acid: M. O. Forster and T. Jack-on.—The Vapour Pressures of Triethylamine, of *syn*-Triethylpyridine, and their Mixtures with Water: R. T. Lattey.—Liquid Triethylamine: R. T. Lattey.—The Action of Sulphuretted Hydrogen on Solutions of Sodium Hydrosulphite: F. S. Snam.—The Alkyl Compounds of Gold. Diethylauric Bromide.—Preliminary Note: W. J. Pope and C. S. Gibson.—Note on the Constitution of Homooidiodityl: F. B. Power and F. Tutin.—The Interaction of Methylene Chloride and the Sodium Derivative of Ethyl Malonate: F. Tutin.—Preparation of Aliphatic Nitro-compounds by the Interaction of the Alkyl Iodides and Mercurous Nitrite: J. C. Rix and P. Neogi.—Some Mercury Derivatives of Camphor: P. E. Marsh and R. de J. Struthers.—Contribution to the Chemistry of the Terpenes. The Oxidation of Limonene with Chromylchloride: G. G. Henderson.—The Synthesis of Acridines and Phenanthracidines: Tetra- and Hexa-methylacridines: Dimethylphenanthracidines: Diethylmethylendiamines: A. Smeier and A. Compton.

FRIDAY, NOVEMBER 8.

ROYAL ASTRONOMICAL SOCIETY.—The Nebulae II iv, 74 Cygni: Max Wolf.—Note on the Permanency of Some Photo-visual Lenses: W. J. S. Lockyer.—Occultation of the Hyades: Walter Heath.—Disappearance of Saturn's Ring System, 1907 October: R. T. A. Innes.—(1) The Ultraviolet Region in Solar Spectra; (2) The Spectrum of Comet d 1907 (Daniel): J. Evershed.—Tables for computing Standard Coordinates on Photographic Plates: A. R. Hinks.

MALACOLOGICAL SOCIETY, at 8.—Description of a New Species of Clathrocolla, probably from Ceylon: H. B. Preston.—On the Mollusca of Birkeat-Gurun, Egypt: J. A. Smith.—*Urobo grandis* (New Guinea); *Sistrum chrysalis*, *Purpura bougei*, *Natica bougei* (New Caledonia); *Uresalpinx walcheri*, *Lixia walgeri* (N. W. Australia); *Amalthea coxi* (Port Stephens); *Pitarica elata* (Sierra Leone); all new species: G. B. Sowerby.—Notes.—The originals of the Illustrations for E. M. da Costa's "Historia Naturalis Testaceorum Britanniae," London, 1778: Alex. Reynell.

PHYSICAL SOCIETY, at 8.—Discussion on Mr. Campbell's Paper on the use of Variable Mutual Inductances.—A Graphic Method for Stream-lines and Equipotential Surfaces: L. E. Richardson.—On the Vibrations of Bars Supported at Two Points with one end Overhanging: Dr. J. Morrow.

MONDAY, NOVEMBER 11.

ROYAL GEOGRAPHICAL SOCIETY, at 8.30.—The Great Douglas Glacier of New Zealand and its Neighbourhood: J. Mackintosh Bell.

TUESDAY, NOVEMBER 12.

INSTITUTION OF CIVIL ENGINEERS, at 8.—The Extension, Widening and Strengthening of Folkestone Pier: H. T. Kerr.—The Tramway Bay Development-Works: S. H. Ellis.

ZOOLOGICAL SOCIETY, at 8.30.—On the Scales of Fish: E. S. Goodrich, F.R.S.—The Rudd Exploration of South Africa. (VII), List of Mammals obtained by Mr. Grant at Beira: Oldfield Thomas, F.R.S., and R. C. Wroughton.—Notes on two African Mammals: R. Lydeker, F.R.S.—Notes on the Feeding of Serpents in Captivity: Dr. P. Chalmers Mitchell, F.R.S., and R. I. Pocock.—Descriptions of new Loricarid Fishes from South America: C. Tate Regan.—Notes on Mayer's Pig-on: Lt. Col. N. Manders.—On some Points in the Structure of *Callitris striata*: F. E. Beddard, F.R.S.

SOCIOLOGICAL SOCIETY, at 8.—The Genealogical Method in Anthropological Inquiry: Dr. W. H. Rivers.

MINERALOGICAL SOCIETY, at 8.—Anniversary meeting.—On Hopeite and other Zinc Phosphates and Associated Minerals from Rhodesia, Broken Hill Mines: L. J. Spencer.—Notes on Zeolites from Cornwall and Devon: A. Russell.—The Question of a Relation between Isomorphism and Pseudomorphism: A. F. Trotter.—On Binnite, Anatase, Brookite and Molybdenite from the Binnenthal: R. H. Solly.—Note on the Crystallisation of Potassium Bichromate: H. A. Miers.

THURSDAY, NOVEMBER 14.

ROYAL SOCIETY, at 4.30.—*Probable Papers*.—On the Cranial and Facial Characters of the Neanderthal Race: Prof. W. J. Sollas, F.R.S.—Some Features in the Hereditary Transmission of the Self-Black and the "Frisch" Coat Characters in Rats: G. P. Mudge.—On the Inheritance of Eye-colour in Man: C. C. Hurst.—On the Result of Crossing Round with Wrinkled Peas, with Special Reference to their Starch Grains: A. D. Darbishire.—On the Ra'e of the Elimination of Chloroform from the Blood after Anaesthesia: G. A. Buckmaster and J. A. Gardner.—Implantation of Actively Proliferating Epithelium: J. O. Walsell-Barratt.

INSTITUTION OF ELECTRICAL ENGINEERS, at 8.—The Dielectric Strength of Insulating Materials and the Grading of Cables: Alexander Russell.

MATHEMATICAL SOCIETY, at 5.30.—Annual General Meeting.—Election of Council and Officers.—On Hypercomplex Numbers: J. H. MacLagan Wedderburn.—Addendum to a Paper on the Inversion of a Repeated Infinite Integral: T. J. A. Bromwich.—Generalisation of a Theorem in the Theory of Divergent Series: G. H. Hardy.—Uniform and Non-uniform Convergence and Divergence of a Series and the Distinction between Right and Left: Dr. W. H. Young.—Application of Quaternions to the Problem of the Infinitesimal Deformation of a Surface: J. E. Campbell.—Nodal Cubics through Eight given Points: J. J. E. Wright.—The Invariants of a Binary Quintic and the Reality of its Roots: Dr. H. F. Baker.—On a Transformation of Hypergeometric Series: Rev. Dr. E. W. Barnes.—On a Transformation of Certain Hypergeometric Series: Prof. M. J. M. Hill.—A General Theorem on Integral Functions of Order less than One-half: J. E. Littlewood.

FRIDAY, NOVEMBER 15.

INSTITUTION OF MECHANICAL ENGINEERS, at 8.—Labour-saving Appliances at the Mines of the New Kleinfontein Co., Transvaal: E. J. Way.

CONTENTS.

	PAGE
Scientific Worthies. XXXVI.—Sir William Crookes, F.R.S. By Prof. P. Zeeman	1
The Soils of Ireland. By A. D. H.	1
Scholarships and Industry. By Prof. Walter M. Gardner	5
Personal Hygiene	5
Our Book Shelf:—	5
Perry: "Practical Mathematics"	6
Rey: "La Theorie de la Physique chez les Physiciens contemporains."—T. P. N.	6
Wood: "How to tell the Birds from the Flowers: a Manual of Flornithology for Beginners"	7
Letters to the Editor.—	7
Winding of Rivers in Plains.—Sir Oliver Lodge, F.R.S.	7
Recalculation of Atomic Weights.—H. E. de W.	8
The Fauna of Madagascar.—Frank E. Beddard, F.R.S.	8
The Interpretation of Mendelian Phenomena.—Geo. P. Mudge; G. Archdall Reid.	8
Newton's Rings in Polarised Light.—P. V. Bevan	9
The Fishes of the Nile. (Illustrated.) By W. C. M.	10
Some Recent Papers on Meteorites. (Illustrated.) By L. J. S.	12
Notes	13
Our Astronomical Column:—	13
Comet Mellish (1907)	17
The Transit of Mercury	18
Changes on Saturn's Rings	18
A Bright Meteor	18
The New Municipal Technical Institute, Belfast. (Illustrated.)	18
London Day Training College for Teachers	19
Immunity to Disease among Plants. By Prof. F. E. Weid.	20
The Bed of the Western Pacific Ocean	21
Hydrology in Egypt	21
University and Educational Intelligence	21
Societies and Academies	22
Diary of Societies	24

THURSDAY, NOVEMBER 14, 1907.

A NEW HANDBOOK OF INORGANIC CHEMISTRY.

Handbuch der anorganischen Chemie. Herausgegeben von Dr. R. Abegg. Band ii., Abt. ii. Pp. ix+700. Price 24 marks. Band iii., Abt. i. Pp. ix+466. Price 17 marks. Abt. iii. Pp. xiv+876. Price 24 marks. (Leipzig: R. Hirzel, 1905-7.)

A HEARTY welcome may be extended to this valuable work of reference, which does for inorganic chemistry much more than Beilstein's famous handbook has done for organic chemistry. It is no mere guide to the recognition and characterisation of the compounds with which it deals. Its aim is beyond this, and its scope is more general. In a word, the editor endeavours to make use of the vast accumulation of physico-chemical data of the past twenty years, and to incorporate them in the descriptive portion of the work, exercising a critical selection of the material employed, and giving at the same time due consideration to theoretical connections and outstanding problems. The periodic system has been adopted as the basis of classification, and the portions of the work already issued deal with the elements of the second, third, and fifth periodic groups respectively. Here it may not be out of place to protest against an aggravating instance of the Teutonic passion for subdivision. The work is to be issued in eight separately paged and indexed volumes, dealing with the eight periodic groups, together with a ninth volume of a general character. One might, therefore, reasonably expect that the numbers of the volumes would correspond to the group numbers of the elements described. Instead of this, we find the elements of the fifth group described in vol. iii., section iii., those of the fourth group presumably in vol. iii., section ii., and so on. Whether the elements of group 6 will be found in vol. iii., section iv., or in vol. iv., section i., remains for the present a subject of agreeable speculation.

Prof. Abegg, in carrying out his scheme, has secured the collaboration of many eminent workers in the domains of inorganic and physical chemistry. Amongst those who contribute to the volumes before us we may mention Marckwald (radium), R. J. Meyer (rare earths), Schenck (phosphorus subgroup), Brauner (atomic weights), and Rohland (technological subjects, e.g. mortar, ultramarine).

The account of the metals of the rare earths and their compounds deserves special mention. The subject is introduced by a general section of nearly fifty pages, in which we are presented with a historical survey, an account of the mode of occurrence and general chemical characteristics of the group, an outline of the methods of extraction and separation of the earths, and a discussion of the valency and atomic weights of the elements. Then follows in detail the subgroup of the cerite earths, with a special account of the separation and purification of lanthanum, pri-

seodymium, neodymium, and samarium. The second subgroup is that of the terbium elements, and the third deals with those of the erbium and yttrium families.

Another noteworthy feature of the work is the treatment of the atomic weights of all the elements by the same hand. Prof. Brauner has accomplished his task admirably. He takes Clarke's "Recalculation of the Atomic Weights" as the source of data up to 1896, and thereafter refers to the original papers, using the reports of the International Commission as a guide. Little is said of the older and less exact determinations, but the more modern work is given in considerable detail, and critically discussed in its relationship, not only to the atomic weight of the element directly concerned, but to that of other elements which may be involved in the actual experiments. To give an idea of the scale on which Prof. Brauner has written, it may be stated that the atomic weight of beryllium occupies five and a half pages, and that of nitrogen no less than thirty-two pages. The author freely criticises the tables of the International Commission in the course of his articles, pointing out, for example, that if $N=14.01$ is correct, which he believes to be the case, then Ag cannot be 107.93 as given in the international table, but must lie between 107.88 and 107.89.

Prof. Abegg's "Handbuch" is admirably printed and got up, and must in future form an indispensable item in every properly equipped chemical library.

ITALIAN BIRDS AND NEOGENESIS.

Avifauna Italica. By Enrico Hillyer Giglioli. Secondo resoconto. Pp. xxiv+784. (Firenze: Coi. Tipi dello Stab. Tipografico s. Giuseppe, 1907.)

ITALIAN ornithologists in particular, and students of palaeartic birds in general, will be grateful to Prof. Giglioli for this revised edition of his most valuable work. Herein he now recognises 496 species as entitled to the rank of Italian birds; but this includes species which have only once been obtained within this area, and at least two which many ornithologists will refuse to regard as species at all.

These two exceptions are of more than passing interest, inasmuch as Prof. Giglioli contends that they furnish good examples of "neogenesis": of the birth of new species *per saltum*.

The first of these two cases is that of a restart obtained by Prof. Giglioli from Sardinia. On data which can only be described as unsatisfactory, the author elects to create a new species—*Ruticilla nigra*—though most of us, on the same evidence, would agree that the examples on which this new species was based were but melanistic specimens of *Ruticilla titys*, the common black restart. This view he rejects, contending that his own hypothesis is the more reasonable.

Far more importance is to be attached to the second case, which Prof. Giglioli describes at some length, not only in the pages of this work, but also in the

Ibis, 1903. Briefly, this concerns an owl which the author then described as a new species—*Athene chiaradia*; in the volume now before us it is accorded still the rank of a species. Though it is scarcely to be expected that ornithologists will recognise this bird as entitled to specific rank, the history which Prof. Giglioli gives of its discovery will never lose its interest.

Within the space at our disposal, it would be impossible to tell the whole story of this most remarkable case. Suffice it to say that the bird upon which Prof. Giglioli founded his new species was a nestling taken from a nest at Pizzocco, in the province of Udine. Though obviously nearly related to the little owl (*Athene noctua*), it differed therefrom, among other things, in having a dark brown instead of a golden-yellow iris—a rather remarkable fact. Naturally, the author at once instituted a search for further examples from this neighbourhood, and two years later this search was rewarded by the discovery of a nest—in close proximity to that from which the original specimen was obtained—containing four nestlings. One of these, be it noted, was a typical *Athene chiaradia*, while the remaining nestlings were as typically examples of the little owl (*Athene noctua*)! Two other nests containing both dark and yellow-eyed young were later found, and finally a nest with both types of young, together with the parents, was taken. Though these parents were undoubtedly "little owls," they were both somewhat abnormal specimens, both in the matter of size and coloration.

It is to be deplored that no attempt whatever was made to induce any of these birds to breed in confinement; or that the parents were not allowed their freedom in the hope that they might at least go on perpetuating these strange aberrations. Instead, every single bird was killed to furnish specimens for the natural history museum at Florence. Thereby some extremely valuable facts were lost to science for ever! Had Prof. Giglioli endeavoured to breed these birds in confinement, he might have succeeded in establishing his hypothesis of "neogenesis." As it is, both this and the two new species which he founds thereon must be put back to await further evidence.

Though in some matters we may not agree with Prof. Giglioli, we have said enough, perhaps, to show that his book is by no means a dull catalogue of the birds of Italy. W. P. P.

PHYSIOLOGY OF ALIMENTATION.

The Physiology of Alimentation. By Prof. Martin H. Fischer. Pp. viii+348. (New York: John Wiley and Sons; London: Chapman and Hall, Ltd., 1907.) Price 8s. 6d. net.

THIS is a small but comprehensive account of modern physiological ideas concerning the important subjects of digestion and absorption. The work of physiologists on these questions has of recent years been both laborious and fruitful. Pawlow has devised new methods of examining the secretions and

the course of their action on the food-stuffs. The epoch-making work of Emil Fischer has thrown new light on their composition, especially in the case of the proteins. The doctrine that enzymes are catalytic agents has taken firm root. The importance of the chemical stimuli to secretion (secretin and other hormones) has been demonstrated by Starling and Bayliss. The sequence of events in the journey along the alimentary tube has been accurately followed by Cannon's shadow photographs. All these points, and many others, are clearly treated by Prof. Martin Fischer in the very useful little book he has published.

The introduction of new names for the enzymes so long familiar as pepsin, trypsin, rennet, and the like, will, it is to be feared, introduce confusion to the student's mind, although the new nomenclature aims at uniformity. It is interesting, no doubt, to see the actual shadow photographs which Cannon took, but they do not lend themselves well to reproduction, and more diagrammatic pictures would have been instructive.

In a few cases the information given is not up-to-date, or is open to question. For instance, Pawlow's results on the stimulation of the nerves of the pancreas require revision in the light of the discovery of secretin. These results are given in full, and a few pages later Starling's discovery of the pancreatic hormone is described, but no attempt is made to correlate the two, nor is any guidance given to the reader in estimating their relative value.

Again, Weinland's ideas on the "adaptation" of the pancreas are quoted with apparent approval, and the confirmation of his views is wrongly attributed to Vernon. No mention, however, is made of the important work of Plimmer, who has conclusively shown that Weinland's results rest on imperfect methods, and that in the cases investigated no adaptation is discoverable.

The distinction between casein and caseinogen is mentioned, but the former is stated to be produced from the latter by the addition of acid, as well as by the action of caseinase or rennet. This view is justifiable if, as some have recently asserted, the difference between the two proteins is one of state of aggregation only, and not a true chemical difference. But before adopting such a view it is necessary to dispose of all the work which tends in the opposite direction, and to explain how it is the two substances differ in elementary composition.

Prof. Fischer assigns the place of protein synthesis in the body mainly to the absorptive epithelium of the intestine, and quotes Aberhalden as holding the same view. No mention, however, is made of the work of others (e.g. Leathes, Howell, and Schryver), which appears to prove that there is no such special seat of synthesis in the wall of the alimentary tract. There are just a few points where adverse criticism appears to be necessary; there always will be differences of opinion between those who interpret the facts of life. Taken as a whole, the book is not only lucid, but correct and instructive.

W. D. H.

SCHOOL ARITHMETIC.

- (1) *Arithmetic for Schools*. By the Rev. J. B. Lock. New edition, revised and enlarged with the assistance of V. M. Turnbull. Pp. vii+480. (London: Macmillan and Co., Ltd., 1907.) Price 4s. 6d.
- (2) *Arithmetic, chiefly Examples*. By G. W. Palmer. Pp. x+339+xlii. (London: Macmillan and Co., Ltd., 1907.) Price 3s. 6d.
- (3) *A Modern Arithmetic, with Graphic and Practical Exercises*. By H. Sydney Jones. Part i. Pp. xii+361. (London: Macmillan and Co., Ltd., 1907.) Price 3s.

WE are generally accustomed to consider that the teaching of arithmetic has gained its prominent place in all modern educational systems for two reasons, viz., on account of (1) its utilitarian value, and (2) its culture value. The writer of a general text-book on arithmetic, as well as the teacher of arithmetic, should have both these ideas prominently before him, and so far as either of them fails to consider the subject from these two points of view, so far does he fail in its presentation. A little consideration shows that at different points in the study of the subject the relative importance of the two reasons for teaching it varies considerably; but generally, its utility must give way to the culture training.

Until within the last twenty years the tendency of all works on arithmetic was to build up a system which paid no attention to either reason, but treated the subject more as a series of detached methods—the more mechanical the better—of solving problems set by the author, by the teacher, or by the examiner. We had, in fact, a period which reminds us of the paid problem-solvers of the fifteenth century. Since then we have had two parallel movements of reform in arithmetical teaching. The first was chiefly confined to the public elementary schools, where the culture value was considered as the only value. Arithmetic was to be treated as a “series of problems,” and inspectors, examiners and teachers went problem-mad. The other movement was found at its height in the evening continuation schools and in the technical schools. In that case, all teaching of arithmetic was considered of importance as it bore on the daily life of the pupils. Fortunately, we now see signs of a combination of these two movements, and provided their relative importance is correctly gauged, the results from the teaching of arithmetic will show a corresponding improvement.

It is interesting to note that each of the three books under review claims to have treated the subject from both points of view, and they all show traces of the two movements referred to above. At the same time they all reveal and will help to promote a weakness in the teaching of arithmetic in the preparatory schools and in the secondary schools. In the public elementary schools of the country the arithmetical education of the pupils until about the age of seven consists of a thorough knowledge of the numbers 1 to 10. This includes the complete analysis and synthesis of each number. Succeed

ing years are taken up with the extension of these principles to 20, and to 100, and this is followed by the four rules. Such work is also taken up in certain preparatory schools. These books seem to be intended for secondary schools, i.e. for pupils from the age of 12 and upwards, and yet they take up the four simple rules. The only satisfactory reason for doing so would be a more rigid and scientific treatment of the subject, with full details as to the development of the processes used. None of the books can be considered satisfactory in this respect, though both Mr. Jones's and Messrs. Lock and Turnbull's books show an advance on previous text-books. It would seem, therefore, that the authors, while recognising that pupils of twelve ought to be ready to take up a more scientific study of arithmetic, are not prepared to look for that improvement in the earlier work which would permit of this step being taken.

All three books show signs of the former school of arithmetic. This is specially seen in the multiplication of money. There is no justification for the retention of the old method of tens which is simply a disguised form of practice. The objection to the direct method usually is that the working has to be roughly done with no definite place in the setting down. That can be easily overcome by setting down the working of each unit directly below that unit. The direct method corresponds closely to the method always used in division. Again, in multiplication and division by decimals, we find one of the many mechanical rules given in each book. These should only be necessary in the case of beginners, and a pupil who thoroughly understands “place values” should not require any of these mechanical aids.

(1) Mr. Lock's arithmetic has now reached its fifth edition, and we can congratulate the author on the improvement of that edition. The omissions from and re-arrangement of the text are all for the benefit of the teaching of elementary mathematics. There are still some traces of the older methods to be found. On p. 67 the old extended method of finding the H.C.F. is given, and alongside is a contracted method (the quotients are not necessary) with the remark, “The work is best arranged thus.” On the succeeding page, however, the authors give the working of two examples in the old style. On pp. 96 and 97 we find a series of examples of continued and complex fractions which we hope the authors will remove from the next edition. The importance given to vulgar fractions generally takes away from the value of the book as a modern text-book of arithmetic.

(2) Mr. Palmer's book is an example of a type of text-book which has become common during the last few years.

“It is chiefly made up of examples. The explanatory matter consists almost entirely of worked-out examples, except in certain parts of the book where explanation seemed necessary in consequence of some departure having been made from the ordinary method of treatment.”

There is no doubt that such a book is the best that one can put in the hands of pupils, but it requires a teacher who is an expert in his subject. We can

therefore recommend Mr. Palmer's book with confidence to those teachers who take a special interest in and make a special study of the teaching of arithmetic. They will probably find rules and methods which they do not approve of, but these can be neglected without any loss. The method of dealing with the multiplication of decimals is open to the objection that without any gain a much more difficult method than the direct one is given. The author makes use of rough approximations before and rough checks after working out an example. These are very good, and should be used in all working, but they should not be made the means of finding the decimal point in approximations. The placing of the point should give no difficulty if a logical method has been adopted throughout the study of decimals.

(3) Mr. Jones's book is a laudable attempt to remove the study of arithmetic from its commercial trammels and widen its scope. We are afraid that, in the attempt, he has overburdened his book. Practical work is introduced at all stages of the work, and the numerous explanatory diagrams will be a useful addition to the teaching of the subject. There are one or two things which strike us as being out of place in a book which is intended for a general course in arithmetic. Thus the tables of weights and measures include some units which are not in general use. The introduction of these tends to specialise the work, a thing which Mr. Jones claims, in his preface, that he desires to avoid. We are sorry to see in an arithmetic of this type the instruction to "move the point." It is always difficult for a teacher to keep before young pupils the reason for the step, and he is not aided when the text-book adopts the mechanical method. Mr. Jones has added an index, an example that ought to be followed by all writers of school text-books.

F. L. G.

OUR BOOK SHELF.

Die typischen Geometrien und das Unendliche. By B. Petronievics. Pp. viii+88. (Heidelberg: C. Winter, 1907.) Price 3 marks.

THE author of this curious work asserts (p. 86) that it is impossible to make a one-one correspondence between the points of a linear segment and the elements of the arithmetical continuum $(0, 1)$; in other words, he not only declines to accept the Dedekind-Cantor axiom, but asserts that it is illogical. His attempted proof (p. 85) involves the assumption of actual infinitesimal segments; thus he says "so entspricht dem ersten Punkte, der sich mit dem o -Punkte berührt, gar keine Zahl in der Zahlmenge $0 \dots 1$, da das entsprechende Segment unendlich klein ist, und dasselbe wird auch für den zweiten, dritten usw. Punkt gelten."

This idea of immediately adjacent yet different points pervades the whole tract, and leads to wonderful paradoxes; an attempt is made to remove the most obvious difficulties by a distinction between real and unreal points (pp. 9, 10), but this is not satisfactory. There is a continual confusion between the idea of space consisting of points and that of points forming "parts" of space. You cannot eat your cake and then look at it; if in one context "point" means something with extension, it should not be treated

elsewhere as having position only. Moreover, no intuition, logic, or metaphysic can get a geometrical thing having extension from two points devoid of it.

Unless something better than this can be said for it, the assumption of actual infinitesimals of different orders in geometry is not likely to be accepted, and the Dedekind-Cantor axiom will probably be retained as the simplest way of connecting geometry with analysis. From the metaphysical side we want something better than a puerile criticism of Cantor's transfinite number-system, vitiated by misunderstandings. Extensional quantities (lengths, volumes, &c.) can be arithmetically defined for figures in an arithmetical space; but no one with an active geometrical imagination can enjoy this way of treating the subject, although he may admire it as a logical feat. Again, take the connectivity of Riemann surfaces, or the classification of knots; here are things with characteristics easily recognised by inspection, but difficult to specify by the arithmetical method; cannot we find some means for testing our intuitions without putting them into this newly invented arithmetical machine? To give a satisfactory answer to the questions arising from the modern aspects of mathematics is a task sufficient to strain the highest philosophical powers; and although Dr. Petronievics has the temerity to declare that Hilbert's "Grundlagen der Geometrie" is logically defective (p. 24, end), he has added little, if anything, which is of value or interest to the discussion.

G. B. M.

Engineering Workshop Practice. By Charles C. Allen. Pp. vii+254. (London: Methuen and Co., n.d.) Price 3s. 6d.

A BOOK for students on engineering workshop practice is, in many ways, more difficult to write than one addressed to those who, from years of actual practice, have gained an intimate knowledge of the elaborate processes by which engines and other machines are produced. The beginner requires ample explanations of processes, which he has probably never seen carried out, but which to the workman are as familiar as his daily paper.

This book, good as it is, would have been much more useful if no attempt had been made to write for the information of both the beginner and the skilled workman; their needs are so different that the result cannot be satisfactory to either class. A typical instance of the consequences of such an attempt occurs on p. 159, with reference to the cutting of vee threads in a lathe. In a short paragraph the author points out, quite properly, that, in taking a cut over the whole form, there is a great tendency to rip the thread, and then goes on to state that the diagrams indicate the proper method, but offers no further explanation of them. To a skilled workman these diagrams are quite unnecessary; to a student they are merely perplexing. He is left to discover, if he can, that one diagram is intended to indicate that the roughing cut is to be taken on one side of the vee, while in a second diagram a tool, apparently floating in mid-air, lies between two objects, which he may or may not recognise as rake gauges. In other cases where explanations of the diagrams are given they are far from being clear; thus on p. 191, in the instructions for cutting helical gears, we are told that "The cutter used must be selected for the number of teeth there would be in a gear with outside diameter equal to the diameter of a circle determined by the curvature of the gauge in this way." But the author gives no intelligible explanation of what "this way" is.

While it is proper to direct attention to blemishes

of this kind, there is no doubt that the author has produced a book of considerable merit, the value of which would be considerably enhanced in future editions if the attempt to deal with the wants of the skilled workman were frankly abandoned.

The text covers most of the elementary operations of the fitting and machine shops, and the graduated exercises are well thought out, and in a well-equipped college workshop under the supervision of a skilled instructor a beginner would no doubt make remarkable progress in the use of tools, and be of real value in a works at the end of the course of instruction.

Steam and other Engines. By J. Duncan. Pp. ix+471. (London: Macmillan and Co., Ltd., 1907.) Price 5s.

THE development of municipal technical schools during the last few years has given a great impetus to the production of books written especially for elementary students. Mr. Duncan's book, on steam and other engines, is an admirable little work of this class, which students in the early part of a course on mechanical engineering will greatly appreciate, for it is well and clearly written, and covers a wide range of modern practice.

There is nothing more attractive to young engineering students than the purely mechanical details of engines, and the wealth of illustrations accompanying the descriptive matter will no doubt prove of great interest.

While the illustrations are a prominent feature of this book, the more important elementary principles of heat-engine theory and applied mechanics are also presented in a very skillful manner. Students working through the course of instruction prescribed, especially if they are able to carry out the experiments and take part in the engine and boiler trials, as the author recommends, will obtain quite a considerable knowledge of steam and other heat engines.

There appear to be very few errors or mistakes of any importance, but occasionally the author is not an accurate guide, as, for instance, when dealing with the flow of steam in an expanding nozzle he incidentally says that "In the case of a liquid the problem is simple as the property of expansibility is absent," a statement in direct contradiction to the actual facts, as students of hydraulics are well aware.

The Elements of Mechanics. A Text-Book for Colleges and Technical Schools. By W. S. Franklin and B. Macnutt. Pp. xi+283. (New York: The Macmillan Co.; London: Macmillan and Co., Ltd., 1907.) Price 6s. 6d. net.

A BOOK on elementary mechanics, which commences by addressing the reader as my young friend, and immediately after, in a lengthy paragraph, draws a comparison between the student and the axolotl, does not seem very promising as a scientific work. This feeling is strengthened when a little further on, in speaking of the laws of motion, one of the authors writes:—

"You, my young friend, must have in some measure my own youthful view, which, to tell the truth, I have never wholly lost, that there is something absurd in the idea of reducing the more complicated phenomena of nature to any orderly system of mechanical law. For to speak of motion is no doubt to call to your mind first of all the phenomena that are associated with the excessively complicated, incessantly changing, turbulent and tumbling motion of wind and water. These phenomena have always had the most insistent appeal to us; they have confronted us everywhere and always, and life is an unending contest with their fortuitous diversity, which rises only too often to irresistible sweeps of destruction

in fire and flood, and in calamitous crash of collision and collapse where all things commingle in one dread fluid confusion."

The book does not, happily, continue in this style after the opening chapter, but commences a systematic treatment of elementary mechanics on familiar lines, which, however, does not present any new features worthy of notice, except that inaccuracies and lack of precision in the statement of scientific principles are numerous. A new text-book on mechanics may be justifiable, if the authors can present the subject in a better way than has been presented before, or in a form more adapted to the wants of its readers, but a comparison of this work with any good elementary treatise on the subject cannot fail to show its inferior character.

E. G. C.

Die Lösung des Problems der Urzeugung (Archigonia, Generatio spontanea). By Martin Kuckuck. Pp. vii+83; with 34 figs. and one table. (Leipzig: Barth, 1907.) Price 3 marks.

DR. KUCKUCK made a mixture of gelatine, peptone, asparagin, glycerine, and sea-water, boiled it for an hour, put it in a sterilised vessel, and added a little chloride of barium, which brought about ionisation. The outcome was the formation of minute bodies like protozoa, which show "nutrition, growth, reproduction (segmentation), inheritance, movement (rotation), and form cell-groups (coenobia of Haeckel), which resemble animal morulae." Barium chloride produces similar morulae in fresh white of egg and in yolk of egg. Drops of sodium nucleineum (Merck), allowed to fall on the surface of the gelatine-peptone-asparagin-glycerine-sea-salt mixture, produce rotating corpuscles, which form loose colonies. The author gives very interesting and striking figures, some drawn, some from photographs, of his artificial cells and cell-colonies. The figures drawn from the artificial morulae would pass muster in a text-book of embryology; the cell-outlines are sharply defined, and each cell has a beautiful nucleus. It seems to us that these and similar experiments would be more interesting, if less were proved.

On this experimental basis, Dr. Kuckuck rears a theoretical superstructure. Mixtures of inorganic and organic substances pass by ionisation into protoplasm. Salts of barium, radium, and nuclei effect this ionisation. The process of organisation is a process of ionisation. It is so now, and it was so in the beginning. The first organisms arose in the sea and were non-nucleated Monera. The nucleated cell arose by the symbiosis of two aniso-electrical non-nucleated cytodes, as is proved by the fertilisation-process, for is not ontogeny a recapitulation of phylogeny? "Everything living has sex (negative and positive ions), and everything is living because it has sex (negative and positive ions): ohne Geschlecht kein Leben." A sort of genealogical tree is given showing the origin of organisms from inorganic substances, so that the Stammbaum is now quite complete, even as to its roots.

J. A. T.

The Flora of Columbia, Missouri, and Vicinity. By F. P. Daniels. The University of Missouri Studies. Science Series, vol. i., No. 2. Pp. x+319. (The University of Missouri, 1907.)

As a study of a local flora, this memoir, furnishing a list of the plants and an ecological survey, forms a suitable volume for the science series of the Missouri University publications.

The flora is characterised by a predominance of genera belonging to the orders Compositæ, Gramineæ, and Leguminosæ. The sedges are numerous, since the species of *Carex* exceed fifty. *Desmodium*, *Mes-*

pilus, and Aster are large genera, and Vernonia provides eight new species. The genus *Quercus* is important both for the number of species and also on account of their dominance in the forests of the area. *Q. alba*, the white oak, *Q. rubra* and *Q. Schneckii*, red oaks, are widely distributed; *Q. macrocarpa*, *Q. platanioides*, and *Q. palustris* occur on the coal measures; *Q. acuminata* and *Q. tinctoria* are also common.

The ecological survey is detailed, almost too detailed, as it loses conciseness owing to the multifarious subdivisions. The forests, as the prevailing features of the district, receive the most attention; the cliff and marsh associations are also important. The characters of the various formations are carefully delineated, and the text furnishes an estimable addition to the literature of plant distribution, but the area has apparently not been surveyed with the view of plotting on a map, nor are any illustrations provided.

The Evolution of Matter, Life, and Mind. By W. Stewart Duncan. Pp. 250. (Philadelphia: Index Publishing Company, 1907.)

THIS is a *vide mecum* of evolutionism, a sequel to a previous volume in which the author sought to show that feeling and energy are alternate states of matter everywhere. Feeling is given out as energy, and energy is experienced as feeling. Both are spiritual or non-substantial, sister properties or manifestations capable of inhering and co-inhering in one universal substance, the ether. The progress of investigation has enabled the author to make his monism even more definite. Matter is being refined away into a mode of motion in the ether. This ether is "the fountain of all being," "the hitherto unknown God." Prof. Larmor and others are theologians in spite of themselves. Helped by abundant quotations, Mr. Duncan gives a sketch of recent investigations as to the nature of matter, and he points out that he anticipated some of them. In 1893, for instance, he contended that an ordinary ray is a succession of such motions of the ether as beget waves with longitudinal as well as transverse elements of vibration, and it was only last year that Prof. J. H. Poynting showed that rays of light do exert energy in the direction of propagation. In the present volume he develops some original speculations, e.g. a theory of radiation and gravitation.

The author tells us that we must believe in the spirituality of matter and of the ether. Physical processes are never complete chains of sequence. Feeling and energising arise alternately in all matter. Animal matter has sprung from vegetable matter, and the latter from inorganic matter (in the Arctic regions). All that we call "matter" is at least sensitive and capable of feeling. It is so because of what it produces, and it is so because the ether is the fountain of all being, physical and mental. Every receiver of energy passes through two states, which correspond to those of every living personality, a subjective state of feeling which results from influence from without, and an ejective state of energising which results from influence from within. We trust that this is all quite clear.

Mr. Duncan gives an account of the origin of everything—including evil—except the ether, which is a scientific name for God. He traces the evolution of all living creatures and of the human mind, showing that the difficulty of thinking out the long genetic process may be in great measure overcome if we start from a broad enough basis—the psychosis of "matter." In the course of his exposition he quotes the story of a delightful orchid, discovered by Mr. E. A. Suverkrup, of Philadelphia, which sends down a tubular stem into the water when it is thirsty, fills

the tip, and coils it up again. "As the last coil is made the water trickles down upon the roots at the other end." When the discoverer touched the leaves, he was "astonished to see the centre stem convulsively coil itself into a spiral like the spring of a watch." Wonders will never cease. Nor is pathos wanting, for on dry ground "it was almost pitiable to see how the tube would work its way over the ground, in search of water that was not."

Ballistic Experiments, from 1864 to 1880. By the Rev. Francis Bashforth. Pp. 33. (Cambridge: University Press, 1907.) Price 1s.

THE pamphlet is interesting reading as an unconscious revelation of the timidity of thought of our military authority. Afraid to trust its opinion, it waited for approbation to come from abroad before expressing a judgment.

Although carried out with our muzzle-loading guns, Mr. Bashforth's experiments were so careful as to require slight modification only to serve for the newest pattern of modern artillery, and the arrangement of his tabular matter for practical use has been adopted universally, and is never likely to be displaced.

Mr. Bashforth is the creator of the science of modern artillery, but our official world considers this a very improper remark to make, at least in his lifetime.

The rapid progress in electromagnetic science has made possible a great improvement in the chronograph, and further experiment is needed urgently if we are to make the best use of manufacture in the production of improved weapons of war.

LETTERS TO THE EDITOR.

[The Editor does not hold himself responsible for opinions expressed by his correspondents. Neither can he undertake to return, or to correspond with the writers of, rejected manuscripts intended for this or any other part of NATURE. No notice is taken of anonymous communications.]

The Origin of Radium.

IN his two interesting letters published in NATURE of September 26 and October 10 respectively, Dr. Boltwood states that he has obtained undoubted proof of the existence of the parent substance of radium, and that he finds it to be allied in chemical properties with thorium. I may be permitted to describe some experiments which afford independent evidence that the parent substance of radium possesses in a chemical sense the properties of thorium, and that it occurs with the latter.

In experiments made with a new intermediate product obtained from thorium to which I have given the name "mesothorium," I was struck by the fact that old preparations of pure thorium contained relatively large quantities of radium. This appeared all the more noteworthy since the monazite sand from which the thorium is prepared contains only a very small quantity of uranium; the radium corresponding to this small amount must consequently have been separated from the thorium during the complicated processes used in extracting the latter.

A few months ago, therefore, I began a systematic investigation of the quantity of radium in samples of thorium salts of different ages. A weighed quantity of the pure nitrate, generally 10 grams, was dissolved in pure water, and the solution boiled and sealed up. After a sufficient interval the radium emanation was collected by boiling the solution, and shortly afterwards, after allowing the thorium emanation to decay, transferred to an electroscope and measured. Samples of thorium nitrate of very different but accurately known ages were placed at my disposal by the firm of Dr. O. Knöfler. It was found as a result that the older the sample the larger was the quantity of radium contained in it. The oldest sample of all, one dating from 1898, contained the greatest amount. In quite a new sample the quantity of radium was very small, 100 grams of the sample

being required for its measurement. The radium present in this case was about 1/100 that contained in the sample nine years old.

It was not to be supposed that an insufficient degree of purity was the cause of the large amount of radium in the old sample, nor is it probable that thorium itself slowly decomposes into radium. I therefore considered that in the technical preparation of thorium an active substance is separated with the latter, and in turn decomposes into radium; it is probably the direct parent substance of radium, for which search has been recently made. In order to test this view, an attempt was made to show the increase in the amount of radium in a solution of thorium; 100 grams of freshly prepared thorium nitrate was examined, the quantity of radium being ascertained. The amount of emanation collected after four days was used for calculating the equilibrium amount, which is reached after about a month. On August 17 the flask was sealed, and again tested on October 10; the amount was double as great as in the previous test at the end of

Forty grams of thorium nitrate prepared at the end of April was examined in the same way and left during the vacation. In this case also there was a marked increase in the amount of radium.

Fifty grams of thorium nitrate made in June, 1907, was precipitated from acid solution with oxalic acid. In the filtrate the quantity of radium was determined, the same being also done in October. In each case the same result was obtained. The parent substance of radium had therefore been precipitated with the thorium. By mistake, the precipitated material was mixed with other thorium preparations, and could not, therefore, be further investigated.

About 1 mg. of radio-thorium (activity about 100,000) was freed as far as possible from radium (the small amount retained being determined) and sealed up on August 15. The solution on October 14 gave the same amount of radium emanation as before. The radio-thorium was prepared from thorianite by means of barium sulphate, and should not, therefore, have contained the parent substance of radium, as, indeed, was actually found to be the case.

Knowing the proportion of uranium and thorium in monazite sand, and assuming that all the thorium and the whole of the parent substance of radium are separated during the extraction of thorium, the life of radium can be calculated by determining the quantity of radium in a given weight of thorium of known age. I have assumed the monazite to contain on the average 0.3 per cent. of uranium and about 5 per cent. of thorium oxide. From this it follows that 1 gram of thorium nitrate in equilibrium with radium contains about $2 \cdot 10^{-3}$ gram of radium bromide. From the values I have found with samples of thorium of different age, the period of decay for radium lies between 2000 and 3000 years. Alterations in the proportions of uranium and thorium would naturally cause corresponding deviations in the value of the constant. The values given, therefore, only indicate approximately the order of magnitude of the period of decay, since I am ignorant of the exact composition of the monazite used as a source of the nitrates investigated.

I hope to publish more accurate details shortly in another place. OTTO HAHN.

Chemical Institute, Berlin.

The Victoria Jubilee Technical Institute, Bombay.

I SEE IN NATURE of November 7 advertisements for a principal and professor of chemistry for the Victoria Technical College in Bombay. Though I have no connection with the institute, and may be charged with unwarrantable interference, I think that it is only fair to intending competitors that certain facts should be made known.

I wish to point out, in the first place, that the management of this institution is in the hands of a board of trustees, and that the principal is not a member of this board, nor has he the right of communicating with the board except through the medium of the honorary secretary. The title of principal does not even secure to the holder of it the exclusive right of calling meetings of the staff, and, in fact, confers nothing more than the power

to enforce discipline. On the occasion of the opening of the new laboratories in February last, I was much impressed by the fact that not only was the principal not among the speakers, but that he and his staff were barely referred to, and that their names only appeared in the descriptive pamphlet which was published for the occasion inside the cover and at the end.

Such were the conditions under which my friend Dr. Mackenzie held the appointment, and it was with no astonishment that I heard on my return from India that he had sent in his resignation. I may add that though Rs. 1000 per mensem with a residence appears to be a good salary, it must be remembered that there is no security of tenure of the appointment, and that the residence offered to Dr. Mackenzie lay between the dustiest road and the busiest railway in the heart of Bombay.

Should any chemist contemplate applying for the "chair" of chemistry with the view of carrying out research in his spare time and ultimately improving his position, I should like to remind him that he will do well to take his library with him. There are no scientific books in Bombay.

Before leaving Bombay I made it clear to some of my friends who are interested in the institute that, in the event of Dr. Mackenzie's resignation being accepted, I should make the facts public, and should warn other scientific men against accepting the appointment upon similar terms. MORRIS W. TRAVERS.

London, November 9.

November Meteors.

THOUGH the general conditions under which the Leonid meteor shower of 1907 takes place are not the most favourable, still a display of moderate intensity may be expected. The shower promises to be most conspicuous on the night of November 16, when moonlight will interfere considerably with observations, especially in the case of the smaller meteors. The following are the times of the various maxima as computed by the writer, the results of these calculations being expressed in Greenwich mean time:—

Leonid epoch, November 15, 9h. The shower, which is of the third order of magnitude, succeeds the epoch, the principal maxima occurring on November 16, 17h., 17h. 30m., and 18h. 30m. There is also a weak secondary epoch on November 17, 10h., the shower in this case preceding the epoch, and having its principal maxima on November 16, 13h. 40m., 18h., and November 17, 2h.

The intensity of the maxima of a meteoric epoch is inversely as the order of magnitude of the shower connected with it. Two showers, though of different intensities, will, as may be seen, take place on the night of November 16.

Scattered through the rest of the month are several interesting minor showers, details of the most remarkable of which will now be given:—

Epoch, November 22, 4h. Shower of tenth order of magnitude. The shower precedes the epoch, the principal maxima occurring on November 20, 8h., November 21, 14h., and November 22, 3h.

Epoch, November 25, 12h. This shower, which is of the ninth order of magnitude, has its principal maxima after the epoch as follows:—November 26, 1h. 50m., November 27, 2h. 30m. and 6h. Of these, the latter two are the heaviest maxima.

Epoch, November 29, 18h. The shower, which is of the fifteenth order of magnitude, follows the epoch, the principal maxima occurring on November 29, 23h., November 30, 18h., and December 1, 4h.

Closely associated with the last shower is another, which occurs early in December, is of the fifth order of magnitude, and has its maxima on December 2, 11h., and December 3, 8h. JOHN R. HENRY.

An Optical Illusion.

THE optical illusion described by Mr. Douglas Carnegie in NATURE of October 18, 1906, may be explained as follows:—

The thaumatrope generally reverses its apparent direction of rotation when the observer shuts one eye, or, better still, both eyes alternately, according to the physiological

law that the observation of a motion which is being stopped is in favourable circumstances followed by the perception of that motion in reversed direction.

The accompanying figure shows the card with its plane passing through the observer *O*. *L* and *R* are the intersections of the circumference of the card with an arbitrary horizontal line. Suppose that the card turns round its axis *PQ* from north to west, the observer will see *L* removing to the left and *R* to the right, and from this he can conclude the exact direction of the rotation, provided that he makes sure of *L* being behind and *R* before *PQ*, and not otherwise. For suppose *L* before *PQ* in *L'* and *R* behind *PQ* in *R'*, the observed removal of these

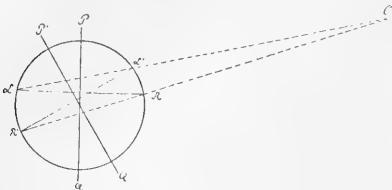

points respectively to the left and to the right would lead to an apparent opposite direction of rotation—from north to east. Moreover, the axis *PQ* perpendicular to *LR* would seem to tilt away from the vertical to *P'Q'* perpendicular to *L'R'*. Hence the illusion depends upon the following condition—if *L* and *R* are seen in the right place with respect to each other, the rotation appears in its true direction, but if, on the contrary, *L* and *R* are seen in *L'* and *R'*, so in the wrong place with respect to each other, the card will seem immediately to reverse its direction of rotation, and the axis will seem to tilt away from the vertical.

As an observer, viewing the true direction of the rotating card, will generally be unable to distinguish the right place of the two points when he shuts one of his eyes, the circumstances are favourable for the reversing of the direction of the rotating card.

Utrecht, October 5.

L. U. H. C. WERNLYD.

The Interpretation of Mendelian Phenomena.

If I have read Dr. Archdall Reid's letter in *NATURE* of October 31 aright, he draws a distinction between the study of heredity in general and the study of the problems of sexual reproduction, now defined as the problem of the function of sex (an expression with which I am perfectly contented). Among the problems of sex he includes the study of the actual transmission of characters as dealt with by Mendelians. The novelty of this classification is certainly attractive; but I find it difficult to understand what branches of knowledge remain to fall under the former head. In what does the study of heredity consist if not in the study of the transmission of characters from parents to offspring?

If by this apparent paradox it is only meant to imply that the Mendelians must confine their study to the transmission of characters by the sexual method, they may seek comfort in the reflection that this is by far the most important of all branches of heredity—it is the only one, for example, which affects the human race. Indeed, the rule that all organisms pass through a sexual cycle at some period of their existence has extremely few exceptions; but I, for one, see no reason for restricting the experimental study of heredity even to this extent. Mendel demonstrated the segregation of the germinal representatives of certain characters in the reproductive cells. What reason is there for doubting that such segregation may take place among the ova of a parthenogenetic individual? There is, in fact, evidence of the actual occurrence of such segregation. More than this, we know of segregation where reproduction is purely vegetative, as in the case of bud sports.

It is the claim of the Mendelians that they have dis-

covered in certain cases some of the fundamental characters of an organism—the units of hereditary transmission, which are represented in the reproductive cells by definite entities known as allelomorphs. Sometimes these characters are identical with those which can be defined by simple inspection previous to experimental analysis, sometimes they are not. Sometimes the apparent character depends upon the simultaneous presence of several allelomorphs, each of which may segregate from its opposite in complete independence of all the others. Mendel himself suggested that this conception, the proof of which he left to his successors, might afford the explanation of certain botanical cases which do not appear to be widely different from that of the mulatto. If Dr. Archdall Reid will produce authenticated pedigrees showing the repeated crossing of the mulatto with pure white blood and pure black blood respectively, together with a detailed account of all the offspring produced, he will make a very substantial contribution to our knowledge of heredity in the human race, and one which will be examined with very great interest by Mendelians. In the absence of such evidence the statement that there is no segregation does not seem to me to be justified, even in this particular instance.

It has been pointed out that Mendel's discovery is leading to a change in our conception of the constitution of an organism comparable with the change which the advent of the atomic theory produced in chemists' conceptions of compound substances. Whatever biological problem we may now discuss, Mendel's facts have to be reckoned with. It is true that the only method so far discovered of studying the constituent characters of organisms consists in the crossing together of individuals in which some of the characters are different. This method is so closely comparable with that by which the chemist studies his compounds that Mendelians have often found a readier appreciation of their views among students of the more precise physical sciences than among biologists. The advantage of introducing exact experiment into the study of heredity ought to be obvious to all, and I fail to see any other objection to the method except its novelty.

If Dr. Archdall Reid desires to grasp this new conception, I can only recommend him to a renewed study of the literature of the subject, beginning with Mendel's own papers. Better still, let him repeat a few of the simpler experiments. There is no royal road to this knowledge; but it is knowledge which is rapidly revolutionising our entire conception of the constitution of a living organism. Dr. Archdall Reid is so far from appreciating this at present that further discussion seems likely to be of very little profit. I will conclude my contribution to this controversy with a word of warning. If Dr. Archdall Reid discards Darwin's opinion, based as it was upon an unequalled experience, that domestic and natural varieties have arisen by essentially the same process, he may find himself landed among a crowd of unsuspected difficulties.

Cambridge, November 2.

R. H. LOCK.

Method of Observing the "Subjective Yellow."

A SIMPLE method of obtaining the sensation of yellow produced by the mixture of red and green lights is afforded by a small direct-vision spectroscop of the ordinary kind in which the slit can be rotated to adjust its line perpendicular to the plane of refraction. If the slit is turned slowly from this normal position, the bands of different colours of course take up a sloping direction across the spectrum, like books on a half-filled shelf. As the slope increases, the upper end, for example of the red, closes down on the lower end of the green, and as the two blend the clear yellow tint is produced. Other colour mixtures can be similarly noticed.

It may be added that if the slit is turned thus until its length lies in the plane of refraction, the violet end of the impure spectrum obtained is drawn out and so more easily observed than in the normal method of use, and is still pure enough for most of the purposes for which a simple spectroscop is of use.

JOHN H. SHAXBY.

University College, Cardiff.

ANTARCTIC ANIMALS.¹

THE Trustees of the British Museum have published in stately form some of the natural history results of the National Antarctic Expedition (1901-1904), and we cannot but express our satisfaction that the volumes compare so well, both in matter and "get-up," with the similar publications of other European nations, and that they can be placed without reproach on the *Challenger* shelves. As the director of the natural history departments of the British Museum says in the preface to this second volume, "neither trouble nor expense has been spared in order to render the illustration and presentation of the natural history of the expedition worthy of the generous efforts both of Captain Scott and his fellow-explorers and of those who provided funds for that

the orqual, the Australian whale (*Neobalaena marginata*), a bottle-nose, the killer (which levies toll on the seals and penguins), the dusky dolphin, and two new cetaceans. Dr. Wilson gives a very interesting account of the habits of the seals:—Weddell's seal (*Leptonychotes weddelli*), the sea-leopard (*Stenorhinus leptonyx*), the crab-eating seal (*Lobodon carcinophagus*), the Ross seal (*Ommatophoca rossi*), the sea-elephant (*Macrorhinus leoninus*), Hooker's sealion (*Arctoccephalus hookeri*). We should like to give an instance of the author's graphic style:—

"Coming back to the ship by boat from Enderby Island an hour or two after sunset, and on a particularly dark night, with neither stars nor moon, we watched the sinuous and graceful movements of about six large sea-lions that followed our boat apparently out of curiosity. Diving and twisting about beneath



FIG. 1.—Emperor Penguins' Rookery at Cape Crozier. From the "National Antarctic Expedition, 1901-1904."

enterprise." Another matter for congratulation is that the results are being published so promptly, and for this thanks are due to the energy and organising ability of Mr. Jeffrey Bell, who has secured the co-operation of specialists, and has acted as sub-editor of the natural history portions of the reports.

The second volume begins with Dr. Edward A. Wilson's report on the mammals, a well-executed piece of work, most beautifully illustrated. The *Discovery* found no traces of the southern right whale (*Balaena australis*), which Sir James Ross reported as abundant in the Ross Sea in the "forties of the last century, but

¹ "National Antarctic Expedition, 1901-1904." Natural History. Vol. ii., Zoology (Vertebrata: Mollusca; Crustacea). Vol. iii., Zoology and Botany (Invertebrata: Marine Algae, Musci), with numerous plates and illustrations. No continuous pagination. (London: Printed by order of the Trustees of the British Museum, 1907.) Vol. ii., 37; vol. iii., 27, 108.

us in the pitch-black water, each animal was ablaze with light. Every limb and every movement could be seen, though they moved so rapidly that the eye could scarcely follow them; they played with one another and chased one another and the boat, now coming up to blow, as we could hear, a yard or two astern, and now diving deep down under the boat to appear often close in under the bulwarks; every stroke of the long powerful fore flippers was accurately conveyed to our eyes in the pitchy darkness by the brilliance of the phosphorescence covering them. . . . The sight was a most beautiful one. The animals moved with feints, and twists, and turns, now in curves, now in circles, but always with the sinuous motion of the body like a fish, supplemented by powerful strokes of the long fore flippers, and always with

the most wonderful rapidity. All this we saw most clearly in the blackest darkness, far more clearly, indeed, than such objects are wont to be seen even under the most favourable conditions, in the daylight."

Of course the memoir is not exactly full of sugar-plums of this sort; there are discussions of dental formulæ and plenty of other hard facts, but Dr. Wilson is to be congratulated on bringing not a little of the picturesqueness of reality into his scientific discourse.

In Dr. Wilson's report on the birds, we find abundant details regarding the life and ways of penguins. They are drawn or photographed in every conceivable attitude and situation—walking, "tobogganing," feeding, sleeping, on the nest and "on the run," crowing, piping, dirty and clean, moulting and "cestatic." The pictures are delightful, and reflect great credit on artists and photographers, and the whole story of the life of the penguins is full of interest. Take the emperor penguin's egg-laying, for instance. The

bird chooses the darkest months of the Antarctic winter in which to incubate its egg; it lays it upon sea-ice with no pretence at nesting, but removes it at once to rest upon its feet, where it is held wedged in between the legs closely pressed to a patch of bare skin in the lower abdomen, and covered from exposure by a loose-falling lappet of abdominal skin and feathers. Of course there is no "pouch," only a fold. The incubation requires seven weeks, and one bird cannot undertake this task. A dozen or more stand patiently round waiting for a chance to assist.

"Every adult bird, both male and female, in the whole rookery has a keen desire to 'sit' on something. There is every reason to believe that when the sitting bird feels hungry it hands over its treasure to the nearest neighbour that will undertake the duty of incubation."

But we must not quote more, strong as the temptation is. Dr. Wilson deals with five species of penguin, two skuas, Wilson's petrel, the Antarctic petrel, the giant petrel, and a score of other birds.

Mr. W. P. Pyecraft has made out some very interesting points in his study of nestlings and embryos of the emperor and Adélie penguins. He shows that penguins develop two successive down plumages before assuming the normal definitive feathers. Another remarkable fact is that the feathers are moulted from large areas of the body at once. In their pterylosis the penguins are the most primitive of all Carinate. This accomplished osteologist also shows that the embryological evidence confirms what

the palæontological evidence hints at, that the penguins are descended from birds which possessed full powers of flight. He gives an interesting discussion of their relationships, and of detailed points of interest such as the sealing up of the nares, which seems to have been a common heritage of all the birds belonging to the great Steganopod branch, except the Colymbi.

The collection of fishes, reported on by Mr. Boulenger, was a very small one, consisting of representatives of ten species, four of which are new.

Dr. W. G. Ridewood deserves congratulation in respect of his fine memoir on the two species of Cephalodiscus obtained by the *Discovery*. He gives a detailed account of *C. hodgsoni*, n.sp., and *C. nigrescens*, Lankester, compares the six species now known, discusses their relations with Rhabdopleura, and clears up a number of obscure details. He proposes to divide the genus into two subgenera—*Idiothecia*, e.g. *C. nigrescens*, in which the polypides live in separate tubular cavities, and *Demiothecia*,



FIG. 2.—Hooker's Sea Lion. From the "National Antarctic Expedition, 1901-1904."

e.g. *C. hodgsoni*, in which the cavity of the tubarium is continuous. In both the new species obtained by the *Discovery* there are hermaphroditic individuals, with one ovary and one testis, as well as males and females with two ovaries and two testes respectively. Some light is thrown on the development of the bulbs and of the tubarium, as also on Harmer's "problematical body" (obliquely interlacing cross-stripped muscle fibres) and on the peculiar refractive beads in the end bulbs of the plumes of *C. hodgsoni* (material of the tubarium in process of secretion). The seven plates illustrating this valuable memoir are of great excellence.

As to brachiopods, Mr. Edgar A. Smith describes two new species of Magellania, one of which, *M. sulcata*, is remarkable on account of the concentric sulcations and the coarse perforations of the shell. Its marked lines of growth have no analogue among recent forms, but recall the surface ornamentation of *Terebratula sulcifera* from the Lower Chalk.

Turning to molluscs, we find that the *Discovery* obtained only one cephalopod—a larval Histioeuthid—

in regard to which Dr. W. E. Hoyle communicates some notes furnished by Dr. G. Pfeffer. There were also some mandibles, obtained from the stomachs of seals and penguins. Mr. Edgar A. Smith finds twenty-one new species of gastropods in a collection of twenty-six. The most striking forms are *Trophon longstaffi*, and a new genus, *Trichoconcha*, which has a flexible tough shell, like a chestnut skin, and a beautiful hairy periostracum. The collection does not show any particular resemblance to the Arctic fauna, most of the genera having a world-wide distribution. The almost total absence of colour in nearly every instance is characteristic. Mr. Smith also describes a very remarkable Chiton (*Chaetopleura miranda*, n.sp.), simultaneously reported by Dr. J. Thiele (*Notochiton mirandus*, n.g. et sp.) from Bouvet Island—an instance of wide distribution. The third and seventh valves are stained red, the rest being dirty-whitish. In the collection of fourteen species of lamelibranchs, Mr. Smith found ten that are new, e.g. a beautifully sculptured Lima (*Limatula hodgsoni*).

Sir Charles Eliot describes five species of pteropods, and points out at once the distinctness and the relatedness of the northern and southern species of *Limacina* and *Clione*. It may be that some once cosmopolitan species have undergone similar but not identical changes in North and South Polar waters. The same authority also reports on the nudibranchs, twelve in all, ten of which are new. He establishes two new genera, *Tritoniella* and *Galvinella*, near *Tritonia* and *Galvina* respectively, and comes to the conclusion that the Antarctic and Arctic nudibranchs are similar rather than identical.

As to crustaceans, Dr. W. T. Calman describes two species of decapods obtained within the Antarctic Circle, viz., *Chorionus antarcticus* (= *Hippolyte antarctica*, Pfeffer) and *Crangon antarcticus*, Pfeffer, both of which were also collected by the German Polar Commission of 1882-3 at South Georgia. With the exception of the very imperfectly known *Crangon capensis*, Stimpson, *C. antarcticus* is the only southern species of the genus, and is widely separated from all the other species, which are confined to the temperate and (if *Sclerocrangon* be included) Arctic regions of the Atlantic and Pacific.

No Cumacea have previously been obtained from within the Antarctic Circle, but the *Discovery* collected four species, which Dr. Calman describes. Three are new, and the fourth is a variety of *Campylaspis verrucosa*, known from the north Atlantic and the Mediterranean, though probably with a much wider range.

Mr. A. O. Walker reports on fifty-three species of amphipods (eighteen new) in forty-three genera (four new). As in the Arctic regions, the Lysianassidae preponderate. It was quite the usual thing to take ten to thirty thousand specimens of *Orchomenopsis rossi* in a single haul. Some of the forms have a wide distribution; thus *Ampelisca macrocephala* is an abundant Arctic species, and the ascidiicolous *Leucothoe spinicarpa* appears to be ubiquitous (the *Discovery's* winter quarters, Ceylon, Maldives, and our own seas). Among the peculiar forms we may notice *Thaumastelton herdmanni*, the only known amphipod with its telson in the vertical plane, *Epimeria macrodonta* with long curved and sharp teeth on the body segments, and *Iphimedia hodgsoni*, so densely clothed with fine spines directed backwards that it has a shaggy appearance.

Dr. Johannes Thiele finds that the only leptostracan collected was *Nebalia longicornis magellanica*; Prof. G. Stewardson Brady reports on nine species of ostracods, of which seven are new, including a new cytherid genus *Linocheles*; Dr. A. Gruvel briefly discusses four cirripedes, including two new species of *Scalpellum*.

Mr. T. V. Hodgson has had an interesting task in dealing with the large collection of pycnogonids, which evidently have their headquarters in southern seas. He describes three new genera and twenty-three new species, raising the total of Antarctic forms to sixty-three. The new genus *Austrodecus*, perhaps a close relation of *Tanystylum*, is a curious little form with a slender and elongated proboscis, like the snout of a weevil beetle, no cheliferi, six-jointed palps, and small ovigers; *Austroraptus*, another new genus, is remarkable for its spurred body and the length of its legs. These two genera, along with the genus *Leionymphon*, which is re-cast, belong to the family *Ammotheidae*, but no true member of the genus *Ammothea* was found. The most interesting form is, of course, *Pentamymphon australis*, which excited much interest at the time, since it has an extra pair of limbs. It is abundant in circumpolar waters, where also the Scottish Expedition, under Dr. W. S. Bruce, collected a still finer species with the same peculiarity, which turned out to be *Decolopoda australis*, described by Eights some seventy years ago in a forgotten paper. The "bipolarity theory" is affected only by *Colossendeis australis*, for it is, among the numerous species of this genus, nearest to *C. proboscidea*, which occurs at the opposite end of the earth. We may direct attention to the useful device Mr. Hodgson has adopted of giving a brief résumé of the most important specific characters at the beginning of each detailed description. The author also contributes an interesting essay at the beginning of the third volume on collecting in Antarctic seas. Dr. E. L. Trouessart describes an Antarctic variety of the Arctic species of halacarid—*Leptospathis alberti*. The two forms hardly differ except in size and proportions, but as the author believes that the species will turn out to be cosmopolitan or subcosmopolitan, he does not attach any importance to its bipolar distribution. As a matter of fact, however, the species is not as yet known except in the two polar seas.

As to "worms," Dr. G. Herbert Fowler reports on three species of *Chaetognatha*. He found the same three and one other in an old *Challenger* collection. He points out that *Krohnia hamata* ranges from 81° 30' N. to 77° 49' S., being cosmopolitan and fairly eurythermal; that *Sagitta hexaptera* is cosmopolitan and pantothermal; and that *S. serrato-dentata*, though found in subantarctic as well as north temperate seas, was absent at the colder stations of both *Discovery* and *Challenger*. Dr. O. von Linstow describes *Leptosomatum australe*, n.sp., which is the largest known free nematode, the female attaining a length of almost 50 mm., the male of 37.7 mm. He proposes a new group, *Adenophori*, for the free nematodes, which will not fit into the three groups *Secernentes*, *Resorbentes*, and *Pleuromyarii* into which he has disposed the parasitic forms. Mr. Arthur E. Shipley describes three species of *Dibothrioccephalus* (two new) which were found living together in the stomach of Ross's seal. It is rather remarkable that the only cestodes brought back by the naturalists of the *Discovery* were got in one rare animal, and that they belong to one genus. The pleuroceroid stages may possibly be found in some cephalopod. We may note the author's enthusiasm; he speaks of *D. wilsoni*, n.sp., as a very attractive little tapeworm of few proglottides.

Turning to *Cœlentera*, we find, first of all, an interesting memoir by Prof. S. J. Hickson on the Aleyonarians. He finds that *Ceratoisis spicata*, n.sp., is a connecting link between the groups of species formerly separated into the two genera *Ceratoisis* and *Primnoisis*. The latter name must now disappear. Another new discovery is *Primnoella divergens*, which links *Primnoella* and *Caligorgia*. The collection in-

cluded another new species of Ceratois and five other forms previously described. Prof. Hickson and Mr. F. H. Graveley deal with the hydroid zoophytes, which include some interesting forms, especially *Hydractinia dendritica*, n.sp. Though there is no definitely new generic type, there are ten certainly new species and five more probably new—a very large proportion out of a total of twenty-five. It may be noted that only two of the twenty-five were got outside the limits of McMurdo Bay and the edge of the great ice-barrier, so that we have here a fine representation of the hydroid fauna from the most southerly limit of our knowledge of marine zoology. It is also interesting to find that three of the species are common on British coasts. Dr. John Rennie makes a note on the extraordinarily long tentacles of some unknown siphonophore. They were about as stout as an ordinary boot-lace and nearly twenty feet in length. Mr. Hodgson gives a graphic account of the difficulties attending their capture.

Among the sponges, Mr. R. Kirkpatrick found four species of Tetractinellids, forty-three Monaxonellids, twenty-four Calcareo, no Keratosa, and ten species of Hexactinellids. He describes the Hexactinellids, of which three were new genera and eight new species.

The third volume ends with a report on the marine algae (Pheophyceae and Floridæ) by Mr. Gepp and Mrs. Gepp, a description of a new coralline by Dr. M. Foslie, and an account of the mosses by M. Jules Cardot. It need hardly be said that with such bulky volumes before us it has not been possible to give more than a hint of the amount of sound and interesting work which they contain.

THE CURE AND PREVENTION OF SLEEPING SICKNESS.

THE sleeping sickness is, and unfortunately continues to be, the most burning problem of European colonisation in equatorial Africa. Like any other medical problem, that of sleeping sickness has two sides, which may be distinguished broadly as prevention and cure. Investigators in all parts of the world have been experimenting actively with the object of finding a drug, or method of treatment, which shall act in sleeping sickness as quinine does in malaria; that is to say, which shall destroy the parasites in the blood, without seriously affecting the health of the patient. Up to the present, the atoxyl treatment has given the best results, but it has often failed to produce more than temporary amelioration, and it is open to doubt if it has produced a complete cure in any case, while, like other arsenical compounds, it may have serious toxic effects. On Thursday last, however, a communication was made to the Royal Society by Drs. H. G. Plimmer and J. D. Thomson, of the Lister Institute, on the effect of certain anti-mony salts; and, to judge from the preliminary experiments on rats, these compounds appear to be far more efficient in their curative action, and at the same time less toxic in their effects, than atoxyl. The experiments will be extended at once to larger animals and to man, and though it would be premature to say that the long-sought-for cure has been found, the outlook is certainly more full of hope than it has ever been before.

The question of the prevention of sleeping sickness is, of course, bound up with the etiology of the disease. It is known that the disease is caused by the presence of a minute flagellate parasite or "trypanosome," first in the blood, later in the cerebrospinal fluid of the patients; and it is known that the trypanosomes are conveyed from diseased to healthy subjects by the bite of one, possibly more than one, of the species of blood-sucking tsetse-flies. It cannot be

too emphatically stated, however, that the tsetse-fly is not, as so often stated, the "cause" of the disease; if the fly be not infected, its bite is harmless, and Koch and others have reported the existence of large areas in which the fly swarms, but in which sleeping sickness does not as yet exist, although the necessary condition for its diffusion is found.

It follows that the problem of prevention may be attacked in two ways; extirpation of the fly, or control of the infection. Considering the vast extent of the range of the species of tsetse-flies in Africa, considering, further, that these flies, being viviparous, have no free larval stages in which they can be destroyed, like mosquitoes, any notion of extirpating tsetse-flies must be considered as frankly utopian. The measures adopted by our Government are wisely directed towards controlling the spread of the infection. Since the fly haunts thick bush on the lake-shore exclusively, the jungle is to be destroyed at all ports, ferries, and landing-places on the lake, where it is unavoidable that human beings should visit the lake-shore; at other points the natives are to be removed from the shore, and persuaded or coerced to live out of the effective range of the fly. Natives known to be diseased are to be segregated, prevented from wandering into the "fly-belts," and placed under treatment. By this means it may be reasonably expected that the spread of the infection may be checked.

There remains, however, the possibility that some wild animal may play a part in spreading the infection, since other animals besides man are known to be susceptible to the trypanosome when inoculated with it in the laboratory. As yet, however, no vertebrate, other than the human species, has been proved to harbour the trypanosome of sleeping sickness in a state of nature. It is well known, however, that other species of trypanosomes, in no way connected with sleeping sickness, are found commonly in wild animals of all classes; and it may be added that the tsetse-flies are quite as willing to suck the blood of a reptile or bird as that of a mammal. Hence there is always the possibility that some species of wild animal may act as a "reservoir" from which the supply of the trypanosome of sleeping sickness may be kept up indefinitely through the agency of tsetse-flies. It is, therefore, of the utmost importance that further researches on the etiology of sleeping sickness should be carried on, with the special object, among others, of discovering any such indigenous source of the disease, for it need hardly be pointed out that it would be of little use to prevent tsetse-flies becoming infected from human beings if they could also obtain the infection from natural sources.

THE POLLUTION OF RIVERS.

ON Thursday, October 31, an influential deputation from the British Science Guild interviewed Mr. Burns, M.P., at the Local Government Board, upon the subject of legislation with respect to the prevention of the pollution of rivers, and the protection of the public against the contamination of shell-fish.

In most directions the tendency to the pollution of our water supplies increases with the demand for pure water, and the area from which such water can be obtained in the neighbourhood of our towns is diminishing. The existing local authorities have conflicting interests when dealing with river pollution, and considerations of guarding the purity of streams are often subordinated to those of refuse disposal and manufacturing requirements. What too often happens is that a sanitary authority, situated toward the head of the stream or upon one of its tributaries,

collects its own drinking water from a comparatively pure source, and then adopts the selfish policy of permitting its refuse matter to enter the stream below its own intake, with too little regard for the needs of its neighbour lower down the course of the same river. Perhaps it is hardly to be expected that, of its own initiative, a sanitary authority will face a great deal of extra trouble and expense (beyond what is necessary for its own purposes) in conserving the quality and quantity of water when the entire benefit is to be reaped by other authorities; and this is one of the reasons why a general policy should be adopted and enforced by a central authority.

Although certain river conservancy boards exist and have done good work, and several county councils have done much to reduce the contamination of streams, these bodies are unable to do all that is necessary. The Rivers Pollution Prevention Act of 1876 was not framed so as to render the assistance which such an Act could be made capable of, and most of our larger rivers course through more than one county or between the existing purely arbitrary boundary of counties. The rivers and watersheds of the country are, moreover, generally too extensive to be embraced by any existing sanitary authority.

The case in favour of putting the whole of the watershed areas under one controlling authority is therefore a very strong one. The matter, both in its magnitude and importance, is clearly a national one, and a central authority for the whole country is what is needed. The duty of such an authority would be to maintain a sufficient sanitary supervision and control over authorities whose districts form important catchment areas for our water supplies, with the view of maintaining the purity and volume of the waters at standards sufficient to meet the domestic and trade demands of the country as a whole. Such an authority would also arbitrate and advise upon points in dispute between sanitary authorities, or between sanitary authorities and local industries—in so far as these matters relate to the contamination of water; and the heavy expenditure now entailed by costly and often ill-advised litigation, frequently leading to unsatisfactory results, would more than pay for the expert handling of matters in dispute by the central authority.

There can be no difference of opinion upon the fact that the central authority in this matter should be the Local Government Board; and in the legislation which it is sought to promote certain powers in the above-mentioned direction would be given to that Board, and, in addition, measures are introduced to protect the public health against the pollution of shell-fish.

Mr. Burns received the deputation in a most sympathetic spirit, and expressed the hope of being able to introduce a Bill, dealing with matters referred to by the deputation, in the spring of next year.

SIR JAMES HECTOR, F.R.S.

DEATH has removed the last of the four distinguished geologists, F. von Hochstetter, Sir Julius von Haast, F. W. Hutton and Sir James Hector, who together laid the main foundations of the geology of the Dominion of New Zealand.

Sir James Hector was born in Edinburgh on March 16, 1834, and was the son of Alexander Hector, a Writer to the Signet. He was educated at the Edinburgh Academy and University, where he matriculated in 1852, took his degree of M.D. in 1856, and served as assistant to Edward Forbes and to Sir James Simpson. His knowledge of natural history and medicine, and the influence of Murchison, gained him the post of surgeon and naturalist to Captain

Palisser's expedition to the Rocky Mountains of British North America. The expedition was in the field from 1857 to 1860, and its best known result was the discovery of the pass by which the Canadian Pacific Railway now crosses from the Great Plains of Canada to the Pacific coast. At the close of the expedition Hector visited the gold-fields of California and northern Mexico, and he reported upon the coal mines of Vancouver Island. On his return to Scotland he wrote a series of papers on the botany, ethnography and physical geography of the Canadian Rocky Mountains, and a paper, of modest length, "On the Geology of the Country between Lake Superior and the Pacific Ocean (between 48° and 56° N. lat.). . . ."

In the year of his return from America he was appointed geologist to the Government of Otago, and there began the main work of his life. He made extensive and arduous journeys through the province of Otago, which still contains the least known and most difficult country in New Zealand. Some of his results were given in 1863 in a New Zealand Parliamentary Paper on "An Expedition to the North-west Coast of Otago," in which he described the discovery of the pass from Martin's Bay to Lake Wakatipu. His success in Otago soon gained Hector promotion from a provincial to a federal appointment. He was made one of the Commissioners for the New Zealand exhibition at Dunedin in 1865, in preparation for which he made a tour through the colony to report on its economic resources; and in the same year he was appointed director of the Geological Survey of New Zealand and of the New Zealand Colonial Museum at Wellington. There, or in his cottage on the Hutt, a few miles away, he lived for more than forty years. During the first half of this time he issued a long series of important contributions to the natural science of New Zealand; their range was wide, for he was director of the zoological museum, the botanical gardens, the meteorological observatory, and the colonial laboratory, as well as of the Geological Survey. He was also for many years Chancellor of the New Zealand University. He nevertheless found time for extensive original researches. He wrote papers on glacial geology, the origin of the rock basins and the volcanic history of New Zealand; his zoological researches were mainly on the Cetacea, seals, and fish, and he wrote on many groups of New Zealand fossils, notably the moas, and on the discovery of the oldest known penguin, *Palæudyptes*. He superintended and edited those valuable series of annual reports issued by the Colonial Museum and by the Geological Survey, beginning in 1867, which are the great storehouse of information on New Zealand geology. In 1868 he married the eldest daughter of the late Sir David Monro, who was then Speaker of the New Zealand Parliament. In 1873 he issued a sketch-map of New Zealand geology, of which the edition issued in 1886, with his "Outlines of New Zealand Geology," is still the best available. In 1870 he compiled an official "Handbook of New Zealand," a work of reference of permanent value, of which a fourth edition was issued in 1886. In that year he also wrote his well-known report on the eruption of Tarawera; he maintained that it was not a normal volcanic, but a hydrothermal eruption, due to a vast explosion of the superheated steam with which the ground around Lake Rotomahana was saturated. This view has not been confirmed for the eruption of Tarawera as a whole, but it is probably correct for the particular explosion which blew up Lake Rotomahana and its famous pink and white terraces.

Hector's work had meanwhile gained world-wide recognition. He had been elected a Fellow of the

Royal Society in 1866; he received the Order of the Golden Cross from the Emperor of Germany in 1874, the decoration of C.M.G. in 1875, and promotion to K.C.M.G. in 1887. He was awarded the Lyell medal of the Geological Society in 1875, and a founder's medal from the Royal Geographical Society in 1891. In the same year Hector was elected the third president of the Australasian Association for the Advancement of Science, and delivered his address on the history of scientific work in New Zealand. But after this period his work became less important. He continued to write short papers; the last which we remember is that on the distribution of the moa in New Zealand, in 1901. But he no longer showed his old energy or success, and the staff of the Geological Survey was transferred to the Mines Department. Hector retained his nominal position as director of the Geological Survey until 1903, but for many years he had no control over the Geological Survey work that was being done in New Zealand. He remained director of the Wellington Museum, the condition of which was often made the subject of severe reproach. Hutton publicly complained in 1899 that the plates that had been prepared years before for the monograph of the fossil Cainozoic mollusca and echinoids of New Zealand were never published, and that the valuable collections of fossils that had been made during the geological survey of the colony were "useless as they now exist in the museum of Wellington." In 1903 Hector resigned his appointments; he had for several years previously exercised little influence on scientific work in New Zealand, but the high value and wide range of his own scientific work, and the inspiring example of the energy and administrative capacity, which for so many years he devoted to the service of his adopted land, will secure him one of the foremost places in the roll of distinguished New Zealand pioneers.

J. W. G.

NOTES.

The following list of those to whom the Royal Society has this year awarded medals was received a few hours too late for insertion in last week's NATURE. The awards of the Royal medals have received the King's gracious approval:—The Copley medal to Prof. A. A. Michelson, of Chicago, For.Mem.R.S., for his investigations in optics; a Royal medal to Dr. E. W. Hobson, F.R.S., for his investigations in mathematics; a Royal medal to Dr. R. H. Traquair, F.R.S., for his discoveries relating to fossil fishes; the Davy medal to Prof. E. W. Morley, of Cleveland, Ohio, for his contributions to physics and chemistry, and especially for his determinations of the relative atomic weights of hydrogen and oxygen; the Buchanan medal to Mr. W. H. Power, C.B., F.R.S., for his services to sanitary science; the Hughes medal to Prof. Ernest H. Griffiths, F.R.S., for his contributions to exact physical measurement; the Sylvester medal to Prof. W. Wirtinger, of Vienna, for his contributions to the general theory of functions.

The honours announced on the occasion of the King's birthday on Saturday last are chiefly of political interest. Prof. T. Clifford Allbutt, F.R.S., has been appointed a Knight Commander of the Order of the Bath, but he is the only Fellow of the Royal Society we have been able to find in the list. The new knights include Dr. W. H. Allchin, Dr. W. J. Thompson, and Mr. Charles Whitehead, who is associated with scientific agriculture. Dr. A. Theiler, Government veterinary bacteriologist, Transvaal, has been appointed a Companion of the Order of St. Michael and St. George.

NO. 1985, VOL. 77]

FURTHER particulars have reached us relating to the scientific expedition that will this month visit the Auckland Islands and the Campbell Islands, primarily to extend the magnetic survey of New Zealand to their sub-Antarctic outliers, but also to make zoological, geological, and botanical observations and collections. The expedition, as announced in NATURE of October 24 (vol. lxxvi., p. 644), has been arranged by the Philosophical Institute of Canterbury. The Government S.S. *Hinewoa* will take the expedition on the occasion of her annual trip to visit the depôts placed on the islands for shipwrecked mariners. Of the two dozen members, about half will be left on the Auckland Islands and the rest on the Campbell Islands, to be picked up on the return of the steamer. Among the zoologists will be Profs. Benham and Chilton and Mr. E. Waite; botany is represented by Dr. L. Cockayne and others, geology by Dr. P. Marshall and others, while the magnetic observers will be headed by Dr. Coleridge Farr, who has been engaged for the last few years in carrying out the magnetic survey of New Zealand.

A SMALL expedition will proceed from New Zealand in December to the Kermadec Islands. Five young enthusiastic men have arranged to spend twelve months on these uninhabited islands, collecting, observing, and photographing. The results of the expedition will, it is hoped, be worked out by naturalists in New Zealand.

A CHRISTMAS course of illustrated lectures, adapted to a juvenile auditory, will be delivered at the Royal Institution by Sir David Gill, K.C.B., F.R.S., on "Astronomy Old and New." The dates of the lectures are December 28 (Saturday), 31; January 2, 4, 7, and 9, 1908.

THE administration building of the Mount Weather Meteorological Observatory of the Weather Bureau was, *Science* reports, destroyed by fire on October 23. The loss is said to be 500*l.*, including some valuable instruments.

THE *Times* of November 7 reports that Sir Alfred Jones, president of the Liverpool School of Tropical Medicine, has received a communication from Dr. Kinghorn from Serenje, Zambesi. Dr. Kinghorn records the finding of tsetse-flies, and states that the general opinion throughout the country is that they are rapidly extending. Otherwise the country is singularly free from insect pests. So far, sleeping sickness has not appeared in the district.

A PAPER on disease prevention in the Territorial Army, with a proposed scheme for placing medical officers of health in relation to it, was read on November 8 by Sir Alfred Keogh, Director-General of Army Medical Staff, before the Society of Medical Officers of Health. He explained why an organised military department of sanitation must be called into existence. If in the Territorial Force the work involved is not done in time of war by those who constantly deal with kindred problems in time of peace, it cannot be efficiently done at all. He proposed to ask the medical officers of health of the country to combine in a voluntary organisation, having for its object the preservation of the health of the men who may one day be required to defend the country; to enrol themselves in the Medical Corps of the Territorial Force; to undertake voluntarily the duty of considering the problems to be solved during active operations within their own home area; to be ready to place their knowledge at the disposal of the authorities commanding their divisions of the Territorial Forces. The sanitary department of the Medical Corps would further consist of non-commissioned officers and men detailed to join battalions for the technical duties of water sterilisation, for disinfection, &c.

SOME interesting facts on the continued falling off in the production of natural indigo were given at a recent meeting of the Society of Chemical Industry by Mr. R. J. Friswell, chairman of the society. From Government returns it appears that for the five years ended 1904-5 the total acreage in India devoted to this cultivation was 755,900 acres. In 1905-6 this had fallen to 330,400 acres, or to less than 44 per cent. of its former area. By 1906-7 it had fallen further to 329,800 acres. Meanwhile, the production of synthetic indigo is advancing by leaps and bounds. No statistics are available as to the actual quantity made by foreign factories, but the imports into our own islands may be taken as a fair index. In 1905 synthetic indigo amounting to 32,246 cwt. was imported. In 1906 this increased to 39,042 cwt., an increase of 21 per cent. During the same years the imports of natural indigo were 8201 cwt. and 7641 cwt. respectively, a decrease of 6.8 per cent. Mr. Friswell thinks that natural indigo will for some years to come occupy a place in the world's market. Planters have, therefore, a breathing time to improve their methods, both biologically and chemically—biologically by improving the content of the plant, chemically by improving the methods of winning the indigo and making its quality constant.

THE International Congress on Tuberculosis will be held in Washington, D.C., from September 21 to October 12, 1908. We have received a preliminary announcement from the National Association for the Study and Prevention of Tuberculosis, which has been entrusted with the organisation of the congress. Dr. Frank Billings is the president of the National Association, and Mr. Roosevelt, Mr. Grover Cleveland, and Prof. William Osler are honorary vice-presidents, Dr. John P. C. Foster and Dr. Mazyck P. Ravenel being the vice-presidents, and Dr. H. B. Jacobs the secretary. The association has appointed a special committee on the International Congress, of which Dr. Lawrence F. Flick, of Philadelphia, is chairman, and Dr. Joseph Walsh, of Philadelphia, secretary. The congress will be divided into seven sections, as follows:—Section i., pathology and bacteriology, president, Dr. William H. Welch, of Baltimore; section ii., clinical study and therapy of tuberculosis—sanatoria, hospitals, and dispensaries, president, Dr. Vincent Y. Bowditch, of Boston; section iii., surgery and orthopedics, president, Dr. Wm. J. Mayo, Rochester, Minn.; section iv., tuberculosis in children, etiology, prevention and treatment, president, Dr. Abraham Jacobi, of New York; section v., hygienic, social, industrial, and economic aspects of tuberculosis, president, Dr. Edward T. Devine, of New York; section vi., State and municipal control of tuberculosis, president, Surgeon-General Walter Wyman, of Washington, D.C.; section vii., tuberculosis in animals and its relations to man, president, Dr. Leonard Pearson, of Philadelphia. The section work of the congress will be carried on in the week September 28 to October 3. During that week there will be two general meetings. A tuberculosis exhibition will be open during the whole time of the congress.

MAYFIELD'S CAVE, Indiana, owing to its short distance ($\frac{1}{2}$ miles) from the University laboratory, was recently selected for systematic exploration, both physiographically and faunistically. The results of this survey form the subject of a paper by Mr. A. M. Banta published by the Carnegie Institution of Washington. In the summary it is pointed out that small caves contain, as a rule, practically the whole cavern-fauna of the district in which they occur, while reference is also made to the probable origin of cave-animals.

OWING to the fact that radical structural differences, constant through large groups, are very few, while minor group-characters, in countless unexpected directions, are extremely numerous and varied, the beetles of the family Tenebrionidæ have always been extremely troublesome to the systematic entomologist. Confronted with this difficulty, Mr. T. L. Casey, in proposing a revised classification of the American representatives of the subfamily Tentyriinæ (Proc. Washington Acad., vol. ix., pp. 276-522), states that he does so with diffidence, although expressing the hope that he is on the right track.

ACCORDING to the report for the year ending on June 30, the Manchester Museum has received a bequest of books and money from the late Mr. Mark Stirrup, many years secretary to the local Geological Society. The interest of the monetary bequest (the first the museum has received) is to be devoted to the improvement of the geological collections. During the year, Prof. Hickson completed his account of the alcyonarian zoophytes obtained during the Antarctic expedition, and likewise identified and described a number of representatives of the same group obtained during the cruise of the *Huxley* in the Bay of Biscay.

OF late years the attention of naturalists interested in the phylogeny of the Insecta has been turned to the Symphyla, a group of arthropods apparently exhibiting to a certain extent characters common to millipedes, centipedes, and thysanurous insects. In the hope of further elucidating the generalised affinities of the Symphyla, Mr. S. R. Williams has therefore investigated the life-history of an American member of the group, *Scutigereella immaculata*, especially in reference to the eggs and the young larvæ, the results of which are published in the Proceedings of the Boston Society of Natural History, vol. xxxiii., pp. 461-485. In possessing seven pair of legs and ten dorsal scales, the larval *Scutigereella* more nearly resembles the adult than is the case with any diplopod of which the early history is known to the author, and it is therefore regarded as a highly specialised type rather than a generalised ancestral form, such as the hexapod larvæ of other diplopods are generally considered.

A MONOGRAPH of the genus *Lepidium*, prepared by Dr. A. Thelling, has been published in vol. xli. of the *Neue Denkschriften der schweizerischen naturforschenden Gesellschaft*. It consists of two parts, the first dealing with synonymy and morphology, the second with the classification of the species. The author splits the genus into five sections, differing slightly from the arrangement proposed by Prantl. The sections are distinguished primarily by the character of the fruit, whether winged or plain, and by the relative length and position of the style compared with the wing. Under morphology the variations in the number and position of the stamens and honey glands are noted; among the fruits, the three-valved capsule borne by a variety of *Lepidium sativum* is peculiar. The species are arranged in three geographical groups, comprising species from Europe, Asia and Africa, from America, and from Australia.

A REPORT on the prevention of malaria in British possessions, Egypt, and parts of America, presented by Prof. Ronald Ross to section vii. of the fourteenth International Congress of Hygiene and Demography, held at Berlin in September, has been reprinted from the *Lancet* of September 28 and issued in pamphlet form. In this report Prof. Ross sums up, so far as possible with the imperfect data at his disposal, the results of anti-malaria measures in British possessions. "The ideal procedure

for towns in the tropics consists (1) in the removal of mosquito-breeding waters; (2) in the treatment of old cases of malaria with quinine; and (3) in the protection, as an additional safeguard, of hospitals, barracks, jails, and as many houses as possible with wire gauze. To these we must add, as insisted upon by Stephens and Christophers, the principle of segregation of Europeans." The campaign at Ismailia has been the most successful one on record, so that in 1906 the Suez Canal Company officially reported that "toute trace de paludisme a disparu d'Ismailia." In this campaign the result is due to mosquito reduction, and also largely to cinchonisation. This example is all the more conclusive because statistics have existed for many years back. Successful and partially successful results have been obtained from many other districts, notably Klang and Port Swettenham, Hong Kong and Khartoum, and especially at Havana and Panama. Many of these results are hard to estimate on account of the insufficient data. That malaria can be stamped out—given the money—under almost any conditions can hardly be doubted; but for those who have doubts an experiment carefully planned, with all statistics carefully controlled and subject to criticism before, during, and after the experiment, would do much to remove prejudices which still exist.

THE Department of Agriculture in the United States has for some time advocated the sowing of early varieties of cotton in districts where the boll weevil flourishes. Another measure for reducing the pest, recommended in Circular No. 95, prepared by Mr. W. D. Hunter, consists in uprooting the cotton plants in the autumn as soon as the crop is cut off by the weevils; many weevils are thereby prevented from developing, and especially those which pass the winter and attack the next season's crop. It is further recommended that the plants be ploughed up and burnt.

MR. C. A. BARBER has contributed to the *Memoirs of the Department of Agriculture in India*, vol. 1, No. 1, the second part of his investigation of the haustorium of *Santalum album*, the sandal-wood tree. The essential parts of the sucker are the cortical folds with which it grips the host root and the central core by which it penetrates. Vessels are developed around the core and in the upper part of the sucker, but there is discontinuity between them. No true bast is formed in the haustorium. The inter-relation between parasite and host is often remarkable. Sometimes the root is fiercely attacked, as in the case of *Cassia auriculata*; in other cases the parasite is unable to penetrate, as in *Zizyphus*. The haustorium may even attack another sandal root, when a fusion results, or a great struggle takes place.

THE greater part of the last issue of the *Kew Bulletin* (No. 9) is given up to an interesting account, communicated by Prof. H. H. W. Pearson, of a journey from Walfish Bay to Windhuk. The author distinguishes a botanical area of Walfish Bay where *Nicotiana glauca*, an Argentine colonist, and the native *Tamarix articulata* grow on the flats, and the cucurbitaceous plant *Acanthosicyos horrida* inhabits the sand dunes. The last-named exhibits a marvellous power of absorbing water and storing it in the stems thickly coated with cork. The dunes give place to a tableland, the "Namib," where *Zygophyllum Stapfii* is prominent. This is also the restricted habitat of *Welwitschia*. Further inland from Usakos to Winterhuk an Acacia park forest occurs. In the same volume the decade of "Diagnoses Africanae" contains two new genera, *Cordeauxia*, a leguminous plant from Somaliland, and *Pegleria*, a genus referred doubtfully to the Rhizophoraceae.

THE Bulletin of the Italian Geographical Society, vol. viii., No. 10, contains a report on the establishment of meteorological stations at the following towns: in Asia Minor:—Marash, Urfa, Diarbekir, Mesereh, Calat Scergat, and Babilonia.

FURTHER observations on the anomaly of the recession and progression of Alaskan glaciers are published by Dr. Otto Klotz in the *Geographical Journal* for October (vol. xxx., No. 4). The "Johns Hopkins" glacier has receded nearly seven miles during thirteen years, whereas the adjacent "Grand Pacific" has receded only about three and a half miles during the same period. Dr. Klotz emphasises the need for more observations of the Alaskan glaciers.

THE disputed question of the appearance of icebergs near the Orkney Islands in 1836 has been again raised by Prof. O. Krümmel in the *Zeitschrift der Gesellschaft für Erdkunde*, No. 7, 1907. Assisted by the marine superintendent of the Meteorological Office in London, Dr. Krümmel has published an extract from the log-book of *S.M.S. Cove* which seems to prove conclusively that two large icebergs were actually observed in the vicinity of the Orkney Islands in January, 1836.

AN ingenious instrument, termed a horticultural hygrometer, has been designed by Messrs. Negretti and Zambra. Buchan and Scott have shown that a knowledge of the temperature of the dew point in the late evening would enable gardeners and others to form a fair estimate of the probable minimum temperature to be expected, as it cannot easily fall below the dew point which existed at nightfall. The instrument in question makes use of this knowledge; it consists of dry- and wet-bulb thermometers, and of a cylindrical scale based upon the relation of the dew point to the difference of the readings of the thermometers. By turning the scale to correspond to this difference, it is seen at once from the position of the wet-bulb reading upon it, without the use of tables, whether the dew point is below freezing, and consequently whether frost may be expected. So far, however, as regular meteorological observers are concerned, we presume that they would probably prefer to rely on the use of simple hygrometrical tables.

THE thick fogs which have prevailed over so large a part of the country of late, and have been more than usually dense in London for so early in the season, have given prominence to the question of the dispersion of fog. A scheme invented by M. Demetrius Maggiora, by which a series of atmospheric vibrations are set up by means of explosions of acetylene or other gas in a strong steel cannon about 60 feet high and 6 feet in diameter, has been under the consideration of the Public Control Committee of the London County Council. Before committing themselves to any action on the subject, the director of the Meteorological Office, Dr. W. N. Shaw, F.R.S., has consented to examine and report upon the proposal and its suitability to the atmospheric conditions of London, and a report on the subject is anticipated at an early date.

SOME South African Tardigrada form the subject of a paper by Mr. James Murray in the *Journal of the Royal Microscopical Society* for October. The material for the paper was received from Mr. W. Milne, of Uitenhage, Cape Colony, in the form of gatherings of moss containing bdelloid rotifers. It yielded eight species of *Echiniscus*, five of *Macrobiotus*, and the one known species of *Milnesium*. Eight of the fourteen species were distinct from any species previously known.

HERBERT SPENCER'S claims as a mathematician form the subject of discussion and criticism at the hands of Dr. J. S. Mackay in the Proceedings of the Edinburgh Mathematical Society (xxv.). The author, referring to the geometrical theorems which Spencer claimed to have discovered, shows that these were well known before Spencer's time, and were not very clearly or lucidly enunciated by Spencer himself. An account of Spencer's views of antipathy towards the metric system and his advocacy of the duodecimal system are also given, but his present critic considers that "his outfit of mathematical (or indeed any other) knowledge was both slender and scrappy."

The occurrence of spinel in blast-furnace slags appears to have been first determined in 1880 by Muirhead, who found that highly aluminous slags left a proportion of very intractable residue, varying from 5 per cent. to 17½ per cent. of the whole weight. This when analysed proved to be spinel with about one-third of the magnesia replaced by iron. An interesting instance of the occurrence of spinel in a Hungarian blast-furnace slag is recorded in an abstract of a paper by Mr. J. Krenner in the October issue of the Journal of the Chemical Society. In a white, enamel-like slag obtained on smelting iron ores rich in manganese, very hard brown octahedral crystals were found. The analysis is in accord with the spinel formula; but this spinel contains more manganese than any artificial or natural member of the spinel group hitherto analysed.

MR. G. H. GULLIVER has contributed to the Proceedings of the Institution of Mechanical Engineers (1907, pp. 519-524) a paper on some phenomena of permanent deformation of metals, the object of which is to correct a hypothesis suggested in a previous paper in 1905 to explain the origin of the "contractile cross." It was then suggested that while the somewhat analogous "Lüders' lines" were due to slipping of the elementary crystals within the crystalline grains of the metal, the contractile cross was the result of the slipping of the irregular crystalline grains themselves over each other. It is now established that for aluminium, and probably for other ductile metals, the phenomena of constriction and fracture are due to excessive "slip-band" deformation, and that the contractile cross passes through the crystalline grains of the metal. It is somewhat influenced by the degree of coarseness of the crystalline structure, but is independent of the directions of the boundaries of the crystalline grains.

A COMPREHENSIVE review of the design, construction, and performance of the Cunard turbine-driven quadruple-screw Atlantic liner *Mauretania* is given in *Engineering* of November 8. The description is accompanied by 186 illustrations, many of which are two-page plates. A similar description was recently published of the *Lusitania*. The *Mauretania* and the *Lusitania* are sister-ships. They are, however, the production of different firms, and differ in numerous details, and particular attention is given in the description to these variations. The *Mauretania*, which has a length over all of 790 feet, a length between perpendiculars of 760 feet, a breadth of 88 feet, a depth, moulded, of 60 feet 6 inches, a gross tonnage of 32,000 tons, and a draught of 33 feet 6 inches, carries 563 first-class passengers, 464 second-class, and 1138 third-class. The average speed on the sea-going trial was 26.03 knots for 1200 miles.

A SIMPLE method of generating an alternating current of any desired frequency is described by Dr. Rudenberg in the *Physikalische Zeitschrift* for October 15. It consists

in placing a capacity, and if necessary an inductance, in series with a series-wound dynamo, and running the machine in the ordinary way. The frequency of the current produced is determined by the capacity and inductance of the circuit, while the power is derived from the machine, which should have its field magnets laminated. A slight modification of the arrangement converts it into a sensitive receiver for wireless telegraphy.

THE *Verhandlungen der deutschen physikalischen Gesellschaft* for September '30 contains an extensive study, by Mr. L. W. Austin, of the conditions which influence the production of rapid electrical oscillations by means of the arc. He finds it possible to generate with carbon, or better with graphite, electrode currents having frequencies of several hundred thousand per second, which, however, are not sinusoidal. The frequency with a direct-current arc increases with the current strength and with diminution of the arc length, but seems to be independent of the intensity of the oscillations. The effect is greatly increased by running the arc in hydrogen. The author recommends for telegraphic work an arc between silver or copper electrodes in air at about six atmospheres pressure, which possesses many of the properties of a rapid spark discharge, and allows a considerable resistance to be introduced into the shunt circuit.

An important contribution to the study of the chemical changes occurring when air is submitted to the influence of electricity is contained in a paper by E. Warburg, and G. Leithäuser in the *Annalen der Physik* (vol. xxiii., p. 210). It is shown that, contrary to the general opinion held hitherto, nitrogen pentoxide is always formed—as well as ozone when air is subjected to the so-called "silent" discharge. The action of ozone on nitrogen pentoxide gives a strongly coloured gas "Y" having the same absorption spectrum as the substance supposed by Hautefeuille and Chappuis to be N_2O_5 ; the amount of "Y" formed is, however, always small in comparison with the quantity of nitrogen pentoxide present, a fact which makes it doubtful whether "Y" really has the composition N_2O_5 , as first supposed, when the assumption was made that it was the only oxide of nitrogen produced by the discharge. Measurements are given of the absorption of light by the substance "Y" in the region of the visible spectrum, and also of the absorption by nitrogen pentoxide in the infra-red. The prominence of an absorption band at 5.75μ in the latter case affords a very delicate means of detecting nitrogen pentoxide when present with other oxides of nitrogen.

THE Industrial Society of Mulhouse has issued a programme of prizes to be awarded by the society during the year 1908. The subjects open for competition this year remain practically the same as those for 1906, already summarised in *NATURE* (vol. lxxiii., p. 164), but a few minor alterations have been introduced. The programme can be obtained on application to the secretary at Mulhouse.

MR. GUSTAV FISCHER, Jena, has just published the fourth revised edition of Prof. W. Kükenthal's "*Leitfaden für das zoologische Praktikum*." A short section on spiders has been added after the chapter on insects. The character of the work was described in a review of the second edition published in *NATURE* of April 24, 1902 (vol. lxxv., p. 581).

THE process of transmitting photographs by electricity devised by Prof. Korn, of Munich, and described in *NATURE* of August 29 (vol. lxxvi., p. 445), has been adopted

by the *Daily Mirror* for use between London and Paris. A demonstration of the methods and results obtained by this process was given at the offices of that journal on Thursday last, November 7.

A SECOND edition, revised and enlarged, of Prof. Prafulla Chandra Ráy's "History of Hindu Chemistry, from the Earliest Times to the Middle of the Sixteenth Century A.D., with Sanskrit Texts, Variants, Translation and Illustrations," has been published by Messrs. Williams and Norgate. The book appeared first in 1902, and was reviewed in the issue of *NATURE* for May 21, 1903 (vol. lxxiii., p. 51). Some material additions have been made to the historical portion of the introduction, throwing further light on the independent origin of the Hindu system of medicine and its priority to that of the Greeks.

THE second volume of the French translation of the third English edition of Mr. W. W. Rouse Ball's "History of Mathematics" has been published by M. A. Hermann, of Paris. The price is 8 francs. The translation is the work of M. L. Freund. The volume has been edited with additions by Dr. R. de Montessus, while M. G. Darboux's paper entitled "Etude sur le Développement des Méthodes géométriques," read at the St. Louis Congress in 1904, is appended. From the same publishers we have received a copy of the second French edition—the work of Mr. J. FitzPatrick—of part iii. of Mr. Rouse Ball's "Mathematical Recreations and Essays"; the translation follows the fourth English edition, and has been enlarged by the inclusion of numerous additions.

MESSRS. GEORGE BELL AND SONS have published a third edition of "A Laboratory Outline of General Chemistry," by Prof. Alexander Smith, professor of chemistry in the University of Chicago, which has been revised in collaboration with Mr. William J. Hale. The first edition of the book was reviewed in our issue for November 9, 1899 (vol. lxi., p. 27). In the preface to the present edition, the authors remark:—"In the effort to make misapprehensions and mistakes as nearly impossible as may be, the directions have been entirely re-written, and in many cases have been amplified, and a number of the experiments have been modified. An entirely new set of figures has also been drawn. To render the exercises more instructive, and still further to discourage mechanical work, a larger number of questions has been inserted."

OUR ASTRONOMICAL COLUMN.

OCCULTATION OF NEPTUNE BY THE MOON.—Dr. Downing directs our attention to an accidental omission from the Nautical Almanac for 1907, of which he publishes particulars in No. 389 (p. 412, November) of the *Observatory*.

The data omitted were the particulars of two occultations of Neptune by the moon, due to take place on November 23 and December 20 respectively, and visible at Greenwich; they are as follow:—

Date 1907	Disappearance				Reappearance			
	Time		Angle from		Time		Angle from	
	Sidereal	Mean	N. point	Vertex	Sidereal	Mean	N. point	Vertex
Nov. 23	h. m.	h. m.	°	°	h. m.	h. m.	°	°
Dec. 20	1 4	8 57	131	171	1 47	9 40	128	200
	11 14	17 20	180	138	11 23	17 29	195	153

NO. 1985, VOL. 77]

THE IMPROVEMENT OF CELESTIAL PHOTOGRAPHIC IMAGES.—In No. 31 (September 10) of the *Lowell Observatory Bulletin*, Prof. Lowell describes a method of combining the use of colour screens and isochromatic plates in the photography of Mars, whereby he has succeeded in obtaining much sharper images of the planet's details. In the first instance, it was seen that the colour curve for the 24-inch object-glass was much flatter in the yellow region, about λ 5000, than elsewhere, and further that the inclination of the curve was much greater on the blue than on the red side of the yellow region. To obtain maximum efficiency, then, it seemed necessary to exclude those rays more refrangible than λ 5000, and to bathe the plates so that the orange and red radiations should become more effective. Accordingly, Mr. Wallace was asked to construct screens which would absorb the rays of lower wavelength than λ 5000, and a Seed "23" plate, bathed with pinachrome and pinacyanol, was exposed in conjunction with the screen. This, however, was unsuccessful, and Prof. Lowell then tried Cramer instantaneous isochromatic plates having sharp maxima at λ 4600 and λ 5650. Using the orange screen, which cut out the λ 4600 maximum, very successful photographs were obtained, and Prof. Lowell hopes that during the opposition of Mars in 1908 this method will produce much better photographs than those already obtained. He places on record that one of his plates taken at the recent opposition showed a canal which had hitherto escaped detection, but was seen for the first time on examining the planet next night.

THE GREAT RED SPOT ON JUPITER.—The acceleration of the Great Red Spot on Jupiter is discussed by Mr. Denning in the *Observatory* for November (p. 411, No. 389), who points out that while the acceleration could be accounted for by the passage of the great S. temperate spot when this occurred, as in 1906, some other explanation must be sought for the acceleration during the past summer, when the S. temperate spot was on the opposite side of the disc to the red spot. Mr. Denning hints at the possibility of there being a minor acceleration when the two objects are in opposition, and indicates the necessity for further careful observations. The S. temperate spot has been visible since 1901, and seems likely to continue so for many years; it was in conjunction with the red spot in May, 1906, and will be so again in April-May, 1908.

RED STARS NEAR NOVA VELORUM.—On examining a plate taken with the 24-inch Bruce telescope on June 6, Mrs. Fleming found the spectrum of a new gaseous nebula, which on further examination proved to be the spectrum of Nova Velorum. This plate includes the region

R.A. 10h. 36m. to 11h. 23m., dec.—51° to —57° (1875),

and shows so many interesting spectra characteristic of red stars that Prof. Pickering publishes a list, in Circular No. 131, giving the C.P.D. designation, the position, the magnitude, and the spectral type of some thirty-four of the included objects. The spectrum of Nova Velorum includes seven bright lines at $\lambda\lambda$ 5013, 4926, 4862, 4643, 4611, 4340, and 4101 respectively, six of which appear to coincide with bright lines in the later spectrum of Nova Persei. The strong helium line at λ 4472, which was bright in Nova Persei (No. 2), is, however, absent from Nova Velorum.

THE SYSTEMATIC ERROR OF LATITUDE OBSERVED WITH A ZENITH TELESCOPE.—From his observations of latitude at Berlin, Herr Battermann found a systematic difference between the latitudes observed by the east-to-west and the west-to-east positions of the zenith telescope. In No. 4207 of the *Astronomische Nachrichten* (p. 97, October 17) Mr. K. Hirayama, of the Tokyo Observatory, discusses this error, basing his conclusions on the results obtained at various stations, and finds that the difference appears to vary with the zenith-distance. As to how the declination of the observed star can affect the reading of the micrometer requires further investigation, but Mr. Hirayama suggests that it may be a physiological effect produced by the varying speed of the star in the field.

INEQUALITIES IN THE MOTION OF THE MOON.¹

THE most interesting result of Prof. Newcomb's researches on the planetary inequalities in the moon's motion is that he has found $1^{\text{h}}.14$ as the theoretical coefficient of the Jupiter evection term. This term was discovered empirically by Prof. Newcomb in 1876, and Mr. Nevill assigned its origin to Jupiter. Dr. Hill and Radau independently computed its coefficient as $0^{\text{h}}.9$. Two or three years ago it was pointed out that the observations indicated a coefficient $1^{\text{h}}.1$, and now Prof. Newcomb has obtained the same result by theory. This term is now worked out; the subject begins and ends with Prof. Newcomb, and has lasted thirty-one years. No indication is given in the memoir before us as to why Hill and Radau concurred in an imperfect value. It was a curious incident, as we know of no other case where any result of either of these two mathematicians has required revision.

In order to illustrate the methods of the memoir, we briefly indicate the process of calculating the Jupiter evection term.

First Stage.—Using the ordinary notation supplemented by $a = \log a$, Prof. Newcomb starts from Delaunay, vol. ii., pp. 235-6 and 800, and obtains on p. 19 the equations of variation

$$\begin{aligned} \frac{d}{d(Nt)} \alpha &= \frac{\alpha}{\mu} \left(\alpha_1 \frac{\partial P_1}{\partial l} + \alpha_2 \frac{\partial P_1}{\partial m} + \alpha_3 \frac{\partial P_1}{\partial \theta} \right) \\ \frac{d}{d(Nt)} \epsilon &= \frac{\alpha}{\mu} \left(\epsilon_1 \frac{\partial P_1}{\partial l} + \epsilon_2 \frac{\partial P_1}{\partial m} + \epsilon_3 \frac{\partial P_1}{\partial \theta} \right) \\ \frac{d}{d(Nt)} \gamma &= \frac{\alpha}{\mu} \left(\gamma_1 \frac{\partial P_1}{\partial l} + \gamma_2 \frac{\partial P_1}{\partial m} + \gamma_3 \frac{\partial P_1}{\partial \theta} \right) \\ \frac{d}{d(Nt)} l_0 &= -\frac{\alpha}{\mu} \left(\alpha_1 \frac{\partial P_1}{\partial a} + \epsilon_1 \frac{\partial P_1}{\partial e} + \gamma_1 \frac{\partial P_1}{\partial \gamma} \right) \\ \frac{d}{d(Nt)} \pi_0 &= -\frac{\alpha}{\mu} \left(\alpha_2 \frac{\partial P_1}{\partial a} + \epsilon_2 \frac{\partial P_1}{\partial e} + \gamma_2 \frac{\partial P_1}{\partial \gamma} \right) \\ \frac{d}{d(Nt)} \theta_0 &= -\frac{\alpha}{\mu} \left(\alpha_3 \frac{\partial P_1}{\partial a} + \epsilon_3 \frac{\partial P_1}{\partial e} + \gamma_3 \frac{\partial P_1}{\partial \gamma} \right) \end{aligned}$$

P_1 being the potential of the disturbing forces.

He also gives (p. 18) the numerical values of α_1 , &c., as follows:—

$$\begin{aligned} \alpha_1 &= +2.0228 & \epsilon_1 &= 0.0168 & \gamma_1 &= -0.0229 \\ \alpha_2 &= -0.0301 & \epsilon_2 &= -19.1534 & \gamma_2 &= -0.0200 \\ \alpha_3 &= +0.0075 & \epsilon_3 &= +0.0026 & \gamma_3 &= -5.5750 \end{aligned}$$

Second Stage.—Neglecting certain small terms, we have for the potential of the direct action of a planet

$$\frac{\alpha}{\mu} P_1 = MK(\xi^2 - \eta^2) - \frac{1}{2}MC(\rho^2 - 3\xi^2) + MD2\xi\eta,$$

and a similar form for the potential of the indirect action

$$\frac{\alpha}{\mu} P_2 = -m^2G(\xi^2 - \eta^2) - m^2J(\rho^2 - 3\xi^2) + m^2I2\xi\eta.$$

For brevity, the sum of the two may be written

$$\frac{\alpha}{\mu} P_1 = 10^{-3}K(\xi^2 - \eta^2) - 10^{-3}C(\rho^2 - 3\xi^2) + 10^{-3}D2\xi\eta.$$

In the above formulæ, ξ , η , ζ , denote the lunar coordinates divided by the moon's mean distance, the axis of ξ being directed towards the mean sun;

$$\rho^2 = \xi^2 + \eta^2 + \zeta^2;$$

and the coefficients MK, MC, MD, m^2G , m^2J , m^2I are known functions of the positions of the earth and the disturbing planet in their orbits. Of these six coefficients, the expansion of the first three in the form

$$\sum \cos i(g_1 - g') + j\delta',$$

i , j being integers, is exceedingly troublesome, and the expansion of the other three assumes that the mutual perturbations of the earth and planet have been calculated.

We are going to illustrate the methods of the memoir by considering as an example the perturbations arising from terms in P_1 with argument

$$2\pi - 2J \text{ or } 2D - 2g + 2g' - 2J.$$

Such a term may arise in P_1 by combining a lunar argument $2D - 2g + jg'$ with a planetary argument

$$-jg' + 2g' - 2J,$$

j being given any integral value; but we will confine our attention to the case $j=0$, which gives rise to the only sensible term of the whole number.

We require, therefore, to pick out the planetary terms with argument $2J - 2g' = N_4$, and the lunar terms with argument $2D - 2g = N$.

The following extracts from the memoir cover the first part of the work:—

From p. 85, Table XXII. :—

$$\begin{aligned} 10^3MK &= +6^{\text{h}}.119 \cos N_4 + 0^{\text{h}}.006 \sin N_4 \\ \frac{1}{2}10^3MC &= -0^{\text{h}}.293 \cos N_4 + 0^{\text{h}}.001 \sin N_4 \\ 10^3MD &= -0^{\text{h}}.005 \cos N_4 + 6^{\text{h}}.114 \sin N_4 \end{aligned}$$

From p. 97, Table XXXIII. :—

$$\begin{aligned} 10^3m^2G &= -24.668 \cos N_4 - 0^{\text{h}}.358 \sin N_4 \\ 10^3m^2J &= -8.969 \cos N_4 - 0^{\text{h}}.061 \sin N_4 \\ 10^3m^2I &= +0.363 \cos N_4 - 23^{\text{h}}.488 \sin N_4 \end{aligned}$$

Hence by addition, p. 145, Table XLV.,

$$\begin{aligned} K' &= +30^{\text{h}}.81 \cos N_4 + (0^{\text{h}}.38 \sin N_4) \\ C' &= -8^{\text{h}}.39 \cos N_4 - (0^{\text{h}}.06 \sin N_4) \\ D' &= (+0^{\text{h}}.35 \cos N_4) - 17^{\text{h}}.37 \sin N_4 \end{aligned}$$

It will soon appear that the six terms of K' , C' , D' fall into two groups of three; one group of three is indicated by brackets, and will not be proceeded with, as the other and more important group suffices for illustration.

Third Stage.—With the notation (see p. 24)

$$\begin{aligned} \xi^2 - \eta^2 &= 2\rho \cos N \\ \rho^2 - 3\xi^2 &= 2\rho \cos N \\ 2\xi\eta &= k \sin N \end{aligned}$$

we extract from Table XL., p. 112, for this argument $N = -2g + 2A - 2A' = 2D - 2g = 2\pi - 2g'$, the values

$$2\rho = +0.007 \ 809 \quad \frac{2\rho}{\epsilon a} = +0.000 \ 30 \quad \frac{2\rho}{\epsilon c} = +0.284 \ 09$$

$$2\eta = +0.001 \ 807 \quad \frac{2\eta}{\epsilon a} = +0.003 \ 73 \quad \frac{2\eta}{\epsilon c} = +0.065 \ 69$$

$$k = +0.007 \ 185 \quad \frac{\partial k}{\partial a} = -0.000 \ 60 \quad \frac{\partial k}{\partial e} = +0.261 \ 69$$

and we note that the differentials with regard to γ are insensible.

These expansions are derived partly from Delaunay's lunar theory and partly from Brown's.

Fourth Stage.—In the differential equations of variation put

$$\frac{\alpha}{\mu} P_1 = 2\rho \cos N,$$

$$\frac{d}{d(Nt)} \alpha = -2\rho \sin N. \alpha_0 \text{ where } \alpha_0 = \alpha_1 + \alpha_2 + \alpha_3$$

(α_1 , α_2 , α_3 are the coefficients of I , π , θ in N , or $2\pi - 2g'$, so that $\alpha_1' = 2$, $\alpha_2' = 0$).

Similarly,

$$\frac{d}{d(Nt)} \epsilon = -2\rho \sin N. \epsilon_0 \text{ where } \epsilon_0 = \epsilon_1 + \epsilon_2 + \epsilon_3.$$

We shall drop the equation for γ , and extract from Table XLVII., p. 146, the values

$$\alpha_0 = -0.0602 \quad \epsilon_0 = -38^{\text{h}}.307,$$

as may be easily verified from the values of $2\alpha_2$ and $2\epsilon_2$ at the beginning of this article.

From Table XLVIII., p. 147, we extract values of products of β , q , $\frac{1}{2}k$ by α_1 and α_2 :—

$$\begin{aligned} \alpha_0\beta &= -0.000 \ 235 & \alpha_0q &= -0.000 \ 054 & \frac{1}{2}\alpha_0k &= -0.000 \ 216 \\ \epsilon_0\beta &= -0.149 \ 20 & \epsilon_0q &= -0.034 \ 28 & \frac{1}{2}\epsilon_0k &= -0.137 \ 90 \end{aligned}$$

Again, noting that

$$\frac{\alpha}{\mu} \frac{\partial P_1}{\partial a} = \left(2 + \frac{\partial}{\partial a} \right) \left(\frac{\alpha}{\mu} P_1 \right)$$

$$-\frac{d}{d(Nt)} l_0 = \left\{ \alpha_1 \left(4\rho + 2\frac{\partial \rho}{\partial a} \right) + \epsilon_1 2\frac{\partial \rho}{\partial e} + \gamma_1 2\frac{\partial \rho}{\partial \gamma} \right\} \cos N = 2L' \cos N$$

$$-\frac{d}{d(Nt)} \pi_0 = \left\{ \alpha_2 \left(4\rho + 2\frac{\partial \rho}{\partial a} \right) + \epsilon_2 2\frac{\partial \rho}{\partial e} + \gamma_2 2\frac{\partial \rho}{\partial \gamma} \right\} \cos N = 2P' \cos N,$$

we shall drop the equation for θ_0 , and noting that when q and k respectively replace β , then L' , P' become in Prof. Newcomb's notation L'' , P'' and L_1 , P_1 .

¹ Investigation of Inequalities in the Motion of the Moon produced by the Action of the Planets. By Simon Newcomb, assisted by Frank E. Koss. Pp. viii+160. (Washington: The Carnegie Institution, 1907).

From Table XLIX., p. 147, we extract:—

$$\begin{aligned} L' &= +0.013 \ 67 \quad 2\epsilon P'' = -0.298 \ 75 \\ L'' &= +0.006 \ 84 \quad 2\epsilon P''' = -0.069 \ 08 \\ L_4 &= +0.023 \ 51 \quad \epsilon P_4 = -0.275 \ 19 \end{aligned}$$

In Prof. Newcomb's value of L' we think a small error (about 0.0020) has been introduced.

Now putting

$$\begin{aligned} \frac{a}{\mu} P_1 &= K_c' \cos N_4 \quad 2\beta \cos N \\ &\quad - C_c' \cos N_4 \quad 2\gamma \cos N \\ &\quad + D_c' \sin N_4 \quad k \sin N \end{aligned}$$

we get

$$\begin{aligned} -\frac{d}{d(nt)} l_0 &= (2K_c' L' - 2C_c' L'' = 2\lambda_1) \cos N_4 \cos N \\ &\quad + D_c' L_4 \sin N_4 \sin N \\ -\frac{d}{d(nt)} \pi_0 &= \left(2K_c' P' - 2C_c' P'' = \frac{2\pi_1}{c} \right) \cos N_4 \cos N \\ &\quad + D_c' P_4 \sin N_4 \sin N \\ \frac{d}{d(nt)} \alpha &\approx (-2K_c' a_0 \beta + 2C_c' a_0 \gamma = 2a_2) \cos N_4 \sin N \\ &\quad + D_c' a_0 k \sin N_4 \cos N \\ \frac{d}{d(nt)} \epsilon &= (-2K_c' \epsilon_0 \beta + 2C_c' \epsilon_0 \gamma = \epsilon_2) \cos N_4 \sin N \\ &\quad + D_c' \epsilon_0 k \sin N_4 \cos N. \end{aligned}$$

At this point we shall reject the terms in $N+N_4$ and write

$$\begin{aligned} -\frac{d}{d(nt)} l_0 &= (\lambda_1 + \frac{1}{2} D_c' L_4 = h_{1c'}) \cos(N-N_4) \\ -\frac{d}{d(nt)} \pi_0 &= (\pi_1 + \frac{1}{2} D_c' P_4 = \epsilon h_{\pi c'}) \cos(N-N_4) \\ \frac{d}{d(nt)} \alpha &= (a_2 - \frac{1}{2} D_c' a_0 k = h_{a2'}) \sin(N-N_4) \\ \frac{d}{d(nt)} \epsilon &= (\frac{1}{2} \epsilon_2 - \frac{1}{2} D_c' \epsilon_0 k = h_{\epsilon c'}) \sin(N-N_4). \end{aligned}$$

Putting ν' = mean motion of moon
mean motion of $N-N_4$

we obtain on integration

$$\begin{aligned} 2\Delta\epsilon &= -2\nu' h_{a2'} \cos(N-N_4) = 2\epsilon c' \cos(N-N_4) \\ 2\Delta\pi &= -\nu' 2\epsilon h_{\pi c'} \sin(N-N_4) = 2\epsilon \pi' \sin(N-N_4), \end{aligned}$$

and by a double integration, remembering that $\Delta x = \frac{2}{3} \frac{\Delta U}{n}$,

$$\Delta l = \nu' \left(\frac{3}{2} \nu' h_{a2'} - h_{1c'} \right) \sin(N-N_4) = l'_c \sin(N-N_4).$$

From p. 153 we extract

$$\begin{aligned} \nu' &= 232.720 \quad l'_c = +0''.256 \\ 2\epsilon c' &= -1''.158 \\ 2\epsilon \pi' &= +1''.164. \end{aligned}$$

Lastly, if we substitute in

$$\delta v = \delta l + 2\delta\epsilon \sin g + 2\cos g (\delta l - \delta\pi)$$

we get

$$\delta v = -1''.15 \sin(g + 2\pi - J).$$

Turning now to the statement of final results on pp. 156-9, we note, with the single exception of the Jupiter evection term, its mainly negative character. Results previously given by Radau and Brown are only very slightly modified, generally by quantities quite insensible to observation. Moreover, no explanation has been reached of the unknown term of long period. Thirty years ago Prof. Newcomb, in what are known as Newcomb's corrections, assigned a coefficient $15''.5$ and a period of 273 years with an argument arising from the action of Venus to this unknown term. It is now known that the argument is impossible. The present writer thinks that both the coefficient and the period require some increase. At any rate, Newcomb's empirical term has now ceased to represent the observed motion of the moon. It is not, of course, to be expected that empiricism will predict with any accuracy for any length of time. In the last paragraph of his memoir, Prof. Newcomb recalls his attempt to establish an inequality in the earth's

rotation that should simultaneously account for the motion of the moon and the transits of Mercury. About forty years ago there was an impression that planetary astronomy had been worked out by Hansen and Le Verrier. The lunar tables of the one and the planetary tables of the other marked immense advances on those of their predecessors, and the extant observations were not sufficient to sound any note of warning except that it might have been noted that Hansen's tables did not account for the ancient eclipses. We now have new planetary tables and the materials for new tables of the moon, but we cannot share the satisfaction of our predecessors of forty years ago. A very considerable list of residual phenomena has accumulated. Apes and nodes and secular terms do not accord with theory. In the moon some periodic terms are unexplained. In Mars it seems as if a term with one second as coefficient and period about twenty years is required to reconcile theory and observation. In the present memoir Prof. Newcomb has presumably excluded the action of the planets as a possible explanation of the vagaries of the moon.

A word ought to be said as to the excellent form of presentation of the subject by Prof. Newcomb. It illustrates the Roman maxim, so often quoted by the late headmaster of Eton, "Divide et impera"—subdivide into sections, and you will get the grip of it.

NEW FACTS ABOUT THE ARUNTA.

THE Arunta of Central Australia have loomed large of late in ethnological controversy, but we are destined to hear further discussion in the near future. Hitherto our information has been derived first from the observations of Mr. F. J. Gillen in part-iv. of "The Report of the Horn Expedition to Central Australia," 1896, and later from the two well-known admirable books by Prof. Baldwin Spencer and Mr. Gillen. In a recent number of *Globus* (Bd. xci., No. 18, p. 285) Herr M. Freiherr v. Leonhardi has an article—"On some Religious and Totemic Conceptions of the Aranda and Loritja in Central Australia," based upon information received from Herr C. Strehlow and Herr Reuther, of the Neuen Detelsaur Mission, who have a mastery over the language of the Arunta, or Aranda. Some of the information thus obtained is so different from that recorded by Spencer and Gillen that it opens a new phase in the discussions concerning these remarkable people. Only the more salient points of Leonhardi's article can be here given; students will have to study it in detail, and they will await with eagerness the promised volume.

The Arunta certainly believe in a supreme, good, heaven-god, called Altjira; he is the god of the upper world, and has little to do with men. He has the appearance of a tall man with a red skin and long hair falling over his shoulders, but he has feet like an emu, he eats vegetable food, and the flesh of the emu, which he spears. He is surrounded by beautiful youths and maidens, who are immortal. The stars are his camp-fires, the Milky Way his hunting-ground. Only certain specially conspicuous stars, such as the evening star, the Pleiades, &c., and sun and moon are ancestors of the Arunta, who once lived on earth and had certain totems. From this Altjira, who lives in heaven, and of whom no Tjurunga (Churinga) exists, must be clearly distinguished the ancestors, honoured as gods and endowed with superhuman powers, who lived on earth sometimes as animals, sometimes as men. In three neighbouring groups the supreme God is distinguished from the totem gods in the following way:—Dieri, supreme being, *Mura*, deified ancestors or totem gods, *Mura-Mura*; Arunta, supreme being, *Altjira* (the Uncreated), totem gods, *Altjira-ngamitjina* (the everlasting Uncreated) or *Intrara* (the Undying); Loritcha, supreme being, *Tukura* (the Uncreated), totem gods, *Tukulita* (the eternal Uncreated). Originally Gillen described a great spirit (*Ulthaana*), of whom no mention was made in the subsequent works, but in these "the most important spirit individual in the Arunta tribe is Twanyirika," though we are told he is not regarded "as a supreme being who in any way whatever was supposed to inculcate moral ideas." Neither is Altjira the guardian of cults and morals.

Herr Leonhardi writes:—"Among the most noteworthy of the discoveries of Spencer and Gillen was the idea that each man is the reincarnation of a totemic ancestor, and that after death, each soul returns to its totem centre, where the spirit individuals spend the time between the two incarnations. These child-germs enter the women, conception by means of men being unknown. In the neighbourhood of whichever totem centre a woman first feels pregnant, that becomes the totem of the child. I was not a little astonished when Herr Strehlow wrote that he could not find any reincarnation theory among the blacks, and that it must be a misunderstanding; but Spencer and Gillen are so positive, 'In every tribe without exception the belief in reincarnation is universal.'" Strehlow writes:—"I have made careful inquiries concerning the points raised. I have inquired of different blacks at different times, among others of three white doctors, who are regarded as guardians of tradition, who grew up in heathendom. They all declare these ideas to be wrong. In different places there are numerous *ratapa* (origins of men, unborn men, who have body and soul, but are invisible). The male origins are in rocks, trees, or in the mistletoe growing on the latter; the female mostly in clefts in rocks. Each *ratapa* belongs to a certain totem, and the *ratapas* of the same totem are collected in one place. This was caused by the totem-ancestors 'getting tired' of their long wandering, and their bodies changed into rocks, trees, &c., and their souls collected in an underground cave. The child-germs are in these rocks and trees, and they go forth thence. If now a woman, who conceives, passes such a mistletoe branch or rock cleft, a *ratapa* enters as a grown youth or girl with body and soul, into her body, causing pain. The *ratapa* grows smaller in the woman's body until later it is born as a child. If an *apma* (snake) *ratapa* enters into a woman, the child belongs to the *apma* totem.

"When a man dies his soul (*etana*) goes, not to the totem centre, but to the island of the dead, where it remains for a time. Eventually it returns to its earlier dwelling place on the earth and says to its former friends, 'Be careful, lest you meet such a fate as mine!' If the dead man has left behind on the earth a small child, his soul enters into it and lives there until the child has grown up and has a beard, when the father's soul departs again, or it enters into his grandson in the same manner. It is finally destroyed by a flash of lightning. Thus one cannot speak of a reincarnation, but only of the temporary dwelling of the soul of the father or grandfather in his son or grandson." Strehlow assures Leonhardi that all the Arunta have the same belief.

"There are other means by which the children enter the women. The *atua ngautja* (souls of totem ancestors dwelling in underground caves) can also enter into the women, if they wish to return to this earth; though their final fate is utter annihilation. A child can enter its mother in animal or plant form. If a woman feels the first intimations of pregnancy immediately after seeing a kangaroo, which runs off and disappears, there is no doubt but that her child will be a kangaroo child.

"Each individual has relationship with two totems, he belongs to the one by birth, or rather by conception, this totem he calls *runga*. The other totem belongs to him, is bound up with him, has communion (*altja*) with him, so he calls it *altjira*. Thus the totem animal or plant of his mother which is forbidden to her to eat is his *altjira*, which belongs to him, of which he can eat as he will. A man named Ebalanga belongs to the iguana totem, so all iguanas are regarded as his friends, or even as his relations, for according to the ideas of the blacks he is himself an iguana. He may kill iguanas but sparingly, and eat only the tail and legs. The wild duck is his mother's totem, this is bound up with him, is his guardian, on whose flesh he feeds." As Leonhardi points out, "the great interest in these new facts is that we have here clearly a totem inherited through the mother. It may be that here is preserved a relic of earlier times, when the totem was inherited directly from the mother, as among so many other Australian tribes, and that the peculiar belief about the conception of children was a later development. As to the primitiveness of the Arunta and their

neighbours, there has been much discussion, and the above facts may give new aspects to the controversy."

A word of warning seems desirable. The Arunta investigated by Herr Strehlow appear to have been Christianised, and some of their statements may have been influenced by the new teaching; also there may be slightly different beliefs among various sections of the Arunta. Doubtless these points will be fully discussed in the final publication.

A. C. H.

UNIVERSITY AND EDUCATIONAL INTELLIGENCE.

CAMBRIDGE.—At the request of the special board for biology and geology, the general board is proposing to establish a demonstratorship in petrology. This demonstrator will be paid by fees, and not directly by the University.

The same board has also received a communication from the special board for biology and geology requesting that the title "Readership in Animal Morphology" (recently vacated by the election of Mr. Adam Sedgwick as professor of zoology) be changed to "Readership in Zoology." This will widen the subject of the readership so that it will include such subjects as variation and heredity, and will enable the University to provide for the teaching of these subjects, which for the last few years has been given by Mr. Bateson as deputy for the professor of zoology. The general board proposes that the annual stipend attached to the readership should be *root.*, to be paid from a common university fund, and that the readership be attached to the board for biology and geology.

The Senate has sanctioned an alteration to the Previous Examination of some moment, although it excited no comment and little interest in the University. In future it will be possible for a candidate to take a paper on elementary heat and chemistry as an alternative to the papers on Paley's "Evidences" and elementary logic. In the same part of the examination a single combined paper on arithmetic and algebra will in future be set instead of the separate papers on those subjects.

There was a discussion last week on the proposal of the medical board to institute a third first M.B. Examination (chemistry, physics, and elementary biology) by holding one at the commencement of the October term. The proposal met with little opposition, though it was pointed out that the time of year was rather inconvenient. Supporters of the scheme hope that in time the October examination will largely take the place of the one held at present in December, and that the latter will ultimately disappear.

The electors to the Isaac Newton studentship give notice that the election to a studentship will be held in the Lent term, 1908. The studentships are for the encouragement of research and study in astronomy. Persons eligible are members of the University who have been admitted to the degree of Bachelor of Arts, and who shall be under the age of twenty-five on January 21, 1908. The studentship is usually of the value of 200*l.* per annum.

PROF. W. F. M. GOSS, one of the leading American authorities on railway engineering, has been appointed Dean of the college of engineering of the University of Illinois.

The Civil Service Commissioners announce, in regard to open competitive examinations for clerkships in the Upper Division of the Civil Service, that, after next year, geography, treated scientifically, will be added to the list of subjects included under the head natural science of which four may be taken up.

A COURSE of eight lectures on the function of the mineral constituents of the soil in the nutrition of plants, by Mr. A. D. Hall, will be given, as part of the advanced lectures in botany of the University of London, in the lecture room of the Chelsea Physic Garden on Mondays and Thursdays, beginning on November 11 at 5 p.m. Dr. O. Rosenheim will give a course of three advanced lectures in physiology

on the borderland of animal and vegetable chemistry (proteins, lecithins, pigments, &c.) at King's College on Mondays, beginning on November 25, at 4.30 p.m.

The Board of Education, South Kensington, has just issued the following list of successful candidates this year for Royal exhibitions, national scholarships, and free studentships (science):—*Royal exhibitions*: W. F. Frew, Plymouth; G. E. Morgan, Portsmouth; E. Grigg, Southsea; E. A. Steed, Devonport; W. E. Curtis, London; H. Carter, Triangle, Halifax; H. W. Turner, Portsmouth. *National scholarships for mechanics (Group A)*: A. W. Judge, Portsmouth; A. Regnaud, London; F. R. Rogers, Devonport; C. Bartlett, Plymouth; F. H. G. Marks, Plymouth; J. H. Thomas, Ovenden, Halifax. *Free studentships for mechanics (Group A)*: S. L. Symms, London; F. A. Bumpus, Birmingham; R. G. M. Frost, Plymouth; E. W. Stedman, Sheerness. *National scholarships for physics (Group B)*: A. G. Tarrant, London; J. Hill, Glasgow; J. Macpherson, Manchester; A. Holmes, Gateshead; W. White, Glasgow. *Free studentship for physics (Group B)*: W. C. Simmons, Southampton. *National scholarships for chemistry (Group C)*: S. R. Illingworth, Shipley; H. Griffiths, Middlesbrough; A. T. Eggington, Ibsstock, Leicester; A. Caruth, Birkenhead; L. W. Burridge, London. *Free studentship for chemistry (Group C)*: F. A. Knott, London. *National scholarships for biology (Group D)*: E. Bateson, Bradford, Yorks; J. Sharpe, Burnley; W. Rushton, Burnley. *National scholarships for geology (Group E)*: C. H. Cunningham, London; T. Eastwood, Burnley; E. J. Wayland, London.

MACDONALD COLLEGE, Quebec, established and endowed by Sir William Macdonald, of Montreal, was opened to students on November 7. The object of the founder is the advancement of education, the carrying on of research, and the spreading of knowledge likely to benefit rural districts, and the training of teachers for rural schools. From an article in the *Times* of November 9, we learn that the college property comprises 561 acres, and has been divided into the campus of 74 acres, where the buildings are located, with demonstration plots for grasses and flowers; a farm of 100 acres for horticulture and poultry keeping; and a live-stock and grain farm of 387 acres. The buildings have been planned in accordance with the most modern scientific principles. The main building includes departments for nature-study and household science, both with appropriate laboratories. Near the main building are buildings for biology and chemistry, each furnished with laboratories and lecture rooms. The main agricultural building contains greenhouses and laboratories of the live-stock farm, dairy, and horticulture department, the farm machinery hall, and a pavilion for live-stock judging. A poultry building with an annexed brooder house are adjacent to the poultry yards, and in addition there is provision for many other agricultural activities. The cost of the buildings and equipment exceeds 300,000*l.*, and, in addition, Sir William Macdonald has provided a permanent endowment of 400,000*l.* The college is incorporated with McGill University, and Dr. James W. Robertson, C.M.G., is the principal. The college includes a school for teachers, a school of household science, and a school of agriculture. Tuition will be free to residents in the Province of Quebec. There will be a small laboratory fee not exceeding 1*l.* to cover the actual cost of the materials used, and a contingency fee to cover possible breakages, penalties, and other demands. Board, room, and washing will be furnished for 13*s.* per week each, where two students occupy one room, and, in the case of students occupying single rooms, for 14*s.*

At the Mansion House, London, a meeting was held on November 6 in furtherance of the interests of the permanent buildings fund of the University College of North Wales, Bangor. At the opening of the proceedings Lord Kenyon read a letter from the Prince of Wales, who, as Chancellor of the University of Wales, heartily wished success to the meeting, and pointed out that since the question of higher education in Wales was taken up by the Government twenty-seven years ago, it has been zealously supported by the people of the Principality. They have recognised it as an essential to their progress and prosperity, and this fresh effort should help Wales

to render the highest services to the kingdom and Empire. A striking proof of this spirit is to be found in the support received from all classes to the original scheme for the college, when 30,000*l.* was raised by 8000 subscribers, of whom only sixty-eight contributed sums of more than 100*l.* and upwards. This spirit has been equally conspicuous in the case of the present appeal, towards which 30,000*l.* has been collected. During the last twenty-three years the successful and steadily increasing work of the college has been carried on in temporary buildings; but from the outset it was the deliberate policy of the college to provide a first-rate staff, and to postpone the question of buildings until the character of the institution had been determined by their efforts. When the Prince of Wales visited Bangor five years ago, the first step towards providing buildings had just been completed by the munificent gift of a site of the value of 15,000*l.* from the corporation. The laying of the foundation-stone by the King this year has now happily inaugurated the actual work of construction. The present intention is to endeavour to complete the arts and administrative section, but it is hoped that in the near future means may be forthcoming to erect the buildings for the science departments, the work of which must for the present be carried on in the old laboratories. A further contribution of 100*l.* towards the building fund was also received from the Prince of Wales, and announced at the meeting. In addressing the meeting, Lord Kenyon referred to the exhaustion of the resources of North Wales and to the depressed state of the slate trade, in connection with which reference was made to the large amount of support the college had received from the ordinary working quarries. Sir Harry Reichel, the principal, gave some interesting statistics showing the same spirit of spontaneous effort in the interests of the Welsh university movement on the part of the middle and working classes of North Wales that was referred to in last week's *NATURE* in connection with the visit of the Chancellor of the Exchequer to Aberystwyth. It was announced that 11,800*l.* had already been subscribed in London alone. It may be interesting to mention that the progress of the college and its influence on the schools of Wales is shown quite as much in the higher standard of attainment of the students as in the increase in numbers. The unmatriculated students, who used to form a large percentage, have now dwindled down to the vanishing point.

SOCIETIES AND ACADEMIES.

LONDON.

Royal Microscopical Society, October 16.—Dr. J. W. H. Eyre, vice-president, in the chair.—Mr. **Taverner** exhibited a number of stereo-photomicrographs of water mites, taken with a stop behind the objective, as described before a previous meeting. They were taken in their natural colours by the Sanger Shepherd three-colour process.—Ghost images in the secondaries of *Coscinodiscus asteromphalus*, with some remarks on the highest useful ratio of magnifying power to aperture: A. A. C. E. **Merlin**. In an experiment suggested by some remarks of Mr. Nelson, the author was able to distinguish perfectly well-defined ghost images of the condenser stop in many of the cap perforations of *Coscinodiscus asteromphalus*. He used a selected Zeiss 3 mm. apochromat of N.A. 1.42 and a 40 ocular in conjunction with a Powell's dry apochromatic substage condenser. The exact size of the perforations was measured and found to be 1/83,300-inch.—A new prismatic ocular: A. A. C. E. **Merlin**. The author found that prolonged observations with the microscope in an upright position entailed great fatigue to the eye, and it occurred to him that by means of a properly designed prism a comfortable position might be secured. He obtained the assistance of Mr. E. M. Nelson, who computed a prism of the kind required, a diagram of which was drawn on the blackboard. It was constructed for the author by Carl Zeiss, and has proved efficient and satisfactory in use.—A new 1/6-inch semi-apochromatic objective: E. M. **Nelson**. The objective had a working distance of 1 mm.; its N.A. was 0.74, and its initial power 60.—Systematic exposure with transmitted light in photomicrography: A. **Lotherby**.

Chemical Society, October 24.—Sir William Ramsay, K.C.B., F.R.S., president, in the chair.—The constitution of phenol- and quinol-phthalein salts: a contribution to the quinonoid theory of colour: A. G. Green and P. E. King. The authors have succeeded in preparing the coloured carboxylic esters of the phthaleins and of their mono- and di-methyl esters. These esters are orange to red, are extremely unstable, being readily saponified, not only by weak acids or alkalis, but even by water. The facts observed disclose an exact parallelism between the esters and salts of these phthaleins and those of fluorescein, and place the quinonoid structure of these substances almost beyond question.—Keten: N. T. M. Wilsmore. The gaseous substance keten, produced by the action of a hot platinum wire on acetic anhydride, which was discovered by Dr. A. W. Stewart and the author (NATURE, 1907, vol. lxxv., p. 510), has been further examined. It has the formula C_2H_2O , and reacts with primary amines to form the corresponding acyl derivatives.—Derivatives of the multiple keten group: J. N. Collie. The group $-CH_2CO-$ (which the author proposes to call the "keten" group) can be made to yield by the simplest reactions a very large number of compounds of types largely obtained from plants. Illustrations of this were given from the various published papers of the author.—Production of orcinol compounds by the action of heat on the sodium salt of ethyl acetoacetate: J. N. Collie and E. R. Chrystall.—A simple gas generator for analytical operations: J. McC. Sanders. A simple constant supply apparatus for hydrogen sulphide was described which is suitable for use in schools and in commercial laboratories.—Some double ferrocyanides of calcium, potassium, and ammonium: J. C. Brown. *Inter alia*, the conditions for the use of ammonium chloride and potassium ferrocyanide as a qualitative test for calcium were given.—Determination of halogen in organic substances: J. Moir. The new method described last year by the author has been improved by adopting the Volhard method of back-titration with standard thiocyanate.—Racemisation by alkali as applied to the resolution of γ -mandelic acid into its optically active isomers: A. McKenzie and H. A. Muller. Various methods of effecting the changes (1) γ -mandelic acid \rightarrow γ -mandelic acid and *l*-mandelic acid, and (2) γ -mandelic acid \rightarrow γ -mandelic acid and *d*-mandelic acid were indicated.—The optical activity of cyclic ammonium compounds: F. Buckley and H. O. Jones. Out of fourteen compounds of this type examined, only one—allyl-kaironinium-*d*-bromocamphorsulphonate—gave conclusive evidence of the existence of optical activity.—The action of phosphorus pentachloride on hydroxytrimethylsuccinic ester. 1:2-Dimethylcyclopropane-1:2-dicarboxylic acid (1:2-dimethyltrimethylene-1:2-dicarboxylic acid): H. Henstock and Miss B. E. Woolley.—The condensation of acetaldehyde and its relation to the biochemical synthesis of fatty acids: H. S. Raper. It has been suggested that the formation of fatty acids in animals depends, firstly, on the breakdown of the carbohydrate to acetaldehyde, and, secondly, on the condensation of this with the formation of the higher fatty acids. This hypothesis is confirmed in part, since it has been found that β -hydroxybutyraldehyde, the first product of the condensation of acetaldehyde, on further condensation yields an aldehyde containing eight carbon atoms united in a straight chain.—The influence of solvents on the rotation of optically active compounds, part x., effect of the configuration and degree of saturation of the solvent: T. S. Patterson, A. Henderson, and F. W. Fairlie.—*para*Toluidine monohydrate: J. Walker and H. H. Beveridge.—Hydrates of some quaternary bases: D. C. Crichton.—Two volumetric methods for the determination of chromium: A. W. Gregory and J. McCallum. The authors describe (1) a modified form of the persulphate method for the estimation of chromium in iron and steel, and (2) a method depending on the oxidation of the chromium with sodium bismuthate.

Faraday Society, October 20.—Mr. N. T. M. Wilsmore in the chair.—The electrolysis of salt solutions in liquefied sulphur dioxide: Dr. Bertram D. Steele. Electrodes of various metals were used, and the changes at anode and cathode studied. With platinum and mercury a rapid

diminution of current took place, when solutions of sulphur dioxide were electrolysed, possibly due to the formation of sulphur films. With electrodes of silver, copper, and iron of large area, constant currents were maintained. Iodine was liberated at anode, but no metallic potassium was obtained at cathode. The author concludes that sulphur cations exist in solution.—The action of aluminium powder on silica and boric anhydride: F. E. Weston and H. Russell Ellis. The authors show that it is possible to obtain silicon and boron by reduction of the respective oxides with extremely finely divided aluminium powder, the oxide being also excessively finely powdered. Great difficulty, however, is experienced in removing the alumina from the metalloids.—The reduction of metallic oxides with calcium hydride and calcium: Dr. F. M. Perkin and L. Pratt. A mixture of copper oxide and calcium hydride reacts with great ease according to the equation $2CuO + CaH_2 = 2Cu + CaO + H_2O$, the ignition taking place by means of a match. Pyrolusite, tinstone, and hematite also react readily, but require to be heated in a furnace or the reaction started by means of a fuse. Zinc oxide appears not to be reduced. Wolframite and rutile react only with difficulty. Lead sulphide and antimony sulphide also react vigorously. Boron can also be produced from boric anhydride or borax and silicon (in small quantities) from silica. Dr. Perkin has already shown the extreme ease with which metallic oxides react with metallic calcium. The authors now show that the reaction with wolframite is particularly energetic, the tungsten being obtained as a fused regulus. Calcium will also replace strontium and barium from their chlorides and hydroxides. It likewise replaces all the alkali metals from their chlorides and hydroxides, the reactions being extremely violent.

PARIS.

Academy of Sciences, November 4.—M. H. Becquerel in the chair.—Comparative study of the phenols as parthenogenetic agents: Yves Delage and P. de Beauchamp. The successful results obtained with tannic acid, described in a previous paper, suggested the trial of other allied substances, the phenols and phenolic acids. Experiments have been made with phenol and the three dihydroxybenzenes, resorcinol being the only active substance of the three latter. Of the trihydroxybenzenes, phloroglucinol is nearly equal in activity to resorcinol, pyrogallol and the unsymmetrical isomer being much inferior. Difficulties of solubility prevented much work being done with the hydroxy-acids. Salicylic and vanillic acids gave poor results, about the same order as phenol; protocatechuic, and especially gallic, acid gave better and more constant results. The suggestion is put forward that the activity of the phenols in parthenogenesis may be proportional to their affinity for oxygen.—Contribution to the therapeutics of trypanosomes: A. Laveran and A. Thiroux. After reviewing the remedies that have been suggested, arsenious oxide, atoxyl, and mixtures of these with mercury salts, and describing their own experimental results on these substances, the authors propose the injection alternately of atoxyl and arsenic trisulphide. This treatment has given very good results in the cure of rats and guinea-pigs artificially infected with *surrea*.—The sugar in the blood plasma: R. Lepine and M. Boulud. The authors lay stress on the large errors introduced into the determination of the amount of sugar in the blood plasma by neglecting the glycolysis which goes on during the separation of the blood corpuscles. They detail the methods by which they in part surmount this difficulty, but conclude that the estimation of the sugar in the blood can only give, at the best, a rough approximation to the amount of sugar carried to the tissues.—Observations of the sun made at the Observatory of Lyons during the second quarter of 1907: J. Guillaume. Observations were possible on forty-eight days, and the results are expressed in tabular form showing the spots, their distribution in latitude, and the distribution of the faculae in latitude.—Hyperelliptic surfaces: G. Bagnera and M. de Franchis.—The adjoint functions of M. Buhl: C. Popovici.—Some properties of integral equations: E. Goursat.—The free path and number of electrons in metals: L. Bloch.—The influence of pressure on the absorption spectra of vapours: A. Dufour. An experi-

mental study of the change in the absorption spectrum of bromine vapour under pressures varying from one to twenty atmospheres.—A new element, lutecium, resulting from the splitting of Marignac's ytterbium: G. Urbain. The separation was effected by fractional crystallisation of the nitrates from nitric acid of density 1.3. The characteristic lines in the arc spectrum of the new element are given. For the purified ytterbium resulting from the separation the name of neo-ytterbium is proposed.—Bis-secondary butylene chlorhydrin: K. Krassousky. An account of this compound, recently discovered as new by M. Louis Henry, was published by the author in 1902. Further details of its preparation and properties are given.—The alkaline granite *massif* of Dahomey: Henry Hubert.—The uratisation of proxone: Louis Duparc.—Remarks on the structure of the alneurone grains in the Gramineæ: A. Guilliermond. The author modifies some conclusions drawn by him in previous publications. The alneurone grains in the Gramineæ offer analogous characters to those of the lupin. They are distinguished only by their smaller content of protein (the latter constituting only a thin layer round the globoids), by the smaller number and larger size of the globoids, and by the insolubility of the protein in potash after fixation by Ladovsky's method or by alcohol.—The experimental production of grapes without pips: Lucien Daniel. The production of ripe grapes without pips can be caused by vigorous pruning immediately after the fruit is set, and is produced by overfeeding at the time when the fertilised seed starts developing with great activity.—The evolution of Frenzelina, intestinal parasites of decapod crustacea: L. Léger and O. Duboscq.—Classification of the Zygoterops according to the characters of their leaf impression: Paul Bertrand.—Variations of density and amount of oxygen of pools of sea water: R. Legendre.—Observation of a discontinuous lightning flash: M. Luizet.

DIARY OF SOCIETIES.

THURSDAY, NOVEMBER 14.

ROYAL SOCIETY, at 4.30.—On the Cranial and Facial Characters of the Neanderthal Race: Prof. W. J. Sollas, F.R.S.—Some Features in the Evolutionary Transition of the Human Face: Prof. W. J. Sollas, F.R.S.—On the Characters in Rats: G. P. Mudge.—On the Inheritance of Eye-colour in Man: C. C. Hurst.—On the Result of Crossing Round with Wrinkled Peas, with Special Reference to their Starch Grains: A. D. Darbishire.—On the Rate of Elimination of Chloroform from the Blood after Anæsthesia: G. A. Buckmaster and J. A. Gardner.—Implantation of Actively Proliferating Epithelium: Dr. J. O. Wacklin-Barratt.

INSTITUTION OF ELECTRICAL ENGINEERS, at 8.—The Dielectric Strength of Insulating Materials and the Grading of Cables: Alexander Russell.

MATHEMATICAL SOCIETY, at 9.—Annual General Meeting.—Election of Council and Officers.—On Hypercomplex Numbers: J. H. MacLagan Wedderburn.—Addendum to a Paper on the Inversion of a Repeated Infinite Integral: T. J. I. A. Bromwich.—Generalisation of a Theorem in the Theory of Derivative Series: G. H. Hardy.—Uniform and Non-uniform Convergence and Divergence of a Series and the Distinction between Right and Left: Dr. W. H. Young.—Application of Quaternions to the Problem of the Infinitesimal Deformation of a Surface: J. E. Campbell.—Nodal Cubics through Eight given Points: J. E. Wright.—The Invariants of a Binary Quintic and the Reality of its Roots: Dr. H. F. Baker.—On a Transformation of Hypergeometric Series: Rev. Dr. E. W. Barnes.—On a Transformation of a Certain Hypergeometric Series: Prof. M. J. M. Hill.—A General Theorem on Integral Functions of Order less than One-half: E. Littlewood.

FRIDAY, NOVEMBER 15.

INSTITUTION OF MECHANICAL ENGINEERS, at 8.—Labour-saving Appliances at the Mines of the New Kleinfontein Co., Transvaal: E. J. Way.

MOVING, at 8.—On the Defects of Dr. Charles Mercier.

TUESDAY, NOVEMBER 10.

ROYAL ANTHROPOLOGICAL INSTITUTE, at 8.15.—Excavation of a Barrow on Chapel Carne Brea, Cornwall, and other Papers: H. King and B. C. Folkinghorne.—The Wild Tides of the Ula Flus: F. W. Knochner.

INSTITUTION OF CIVIL ENGINEERS, at 8.—Discussion.—The Extension, Widening and Strengthening of Folkestone Pier: H. T. Kerr.—*Probable Paper*.—The Tramway Bay Development Works: S. H. Ellis.

ROYAL TRANSMITTAL SOCIETY, at 5.—Presidential Address: The Right Hon. Sir Charles W. Dilke, Bart., M.P.

WEDNESDAY, NOVEMBER 20.

GEOLOGICAL SOCIETY, at 8.—Glacial Beds of Cambrian Age in South Australia: Rev. W. Howchin.—On a Formation known as "Glacial Beds of Cambrian Age" in South Australia: H. Basewood and J. D. Hillier.

ROYAL METEOROLOGICAL SOCIETY, at 7.30.—Discussion.—The Ballon Ascents, July 22 to 27, 1907: Reports by W. H. Dines, F.R.S., J. E. Peisvel, F.R.S., W. A. Harwood, Capt. C. H. Ley, R.E., and Prof. W. E. Thrift.—Discussion of the Meteorological Observations made at the British Kite Stations, 1906-7: Miss M. White, T. V. Pring, and J. E. Peisvel, F.R.S.

ENTOMOLOGICAL SOCIETY, at 8.

ROYAL MICROSCOPICAL SOCIETY, at 8.—(1) François Watkins' Microscope; (2) A Reply to Prof. Porter's and Mr. Everett's Criticism upon the Paper,

On the Limits of Resolving Power for the Microscope and Telescope: E. M. Nelson.—Mercury Globules as Test Objects for the Microscope: J. W. Gordon.—Light Filters for Photomicrography: E. Moffat.

SOCIETY OF ARTS, at 8.—Inaugural Address by Sir Stewart Colvin Bayley, K.C.S.I.

THURSDAY, NOVEMBER 21.

ROYAL SOCIETY, at 4.30.—*Probable Paper*.—Results of the Interaction of Mercury with Alloys of Other Metals: J. W. Mallet, F.R.S.—On the Sensibility of the Ear to the Direction of Explosive Sounds: A. Mallock, F.R.S.—On the Silver Voltmeter: Part I, A Comparison of Various Forms of Silver Voltmeters: F. E. Smith; and a Determination of the Electrochemical Equivalent of Silver: F. E. Smith and T. Mather, F.R.S.; Part II, The Chemistry of the Silver Voltmeter: F. E. Smith and Dr. T. M. Lowry.—On the Normal Wetness Cadmium Cell: F. E. Smith.—On a Method of Depositing Copper upon Glass from Aqueous Solutions in a Thin Brilliantly Reflecting Film, thus Producing a Copper Mirror: Dr. F. D. Chattaway, F.R.S.—On Living Specimens of the Mechanical Equivalent of Light: Dr. C. V. Drysdale.—The Dispersion of Double Refraction in Relation to Crystalline Structure: T. H. Havelock.

CHEMICAL SOCIETY, at 8.30.—The Interaction of Metallic Sulphates and Caustic Alkalies: S. P. U. Pickering.—The Chemistry of Bordeaux Mixture: S. P. U. Pickering.—Aromatic Azinoides. Part II, The Naphthylazoinoids and their Nitro-derivatives: M. O. Forster and H. E. Fierz.—Studies of Dynamic Isomerism. Note on the Action of Carbonyl Chloride as an Agent for Arresting Isomeric Change: T. M. Lowry and E. H. Magnus.—Emulsions: S. P. U. Pickering.—The Electrochemical Measurement of the Hydrolysis of the Salts of Anilinum, Ammonium, Aluminium, Chromium, Thallium, Zinc, Magnesium, Cerium, Thorium, Nickel and Cobalt: H. G. Denham.

INSTITUTION OF MINING AND METALLURGY, at 8.

LINNEAN SOCIETY, at 8.—Albomorphs.—Structures in Leaves, and their Value for Morphology: W. C. Worsdell.—Specimen-preservation in Australian Museums: J. G. Otto Tepper.—Revision of the Genus *Hilgera*, Blume: S. T. Dunn.—*Exchites*: Luminous Larva from British Guiana: C. W. Anderson.—Living Specimens of *Peripatus*, from South Africa: Prof. A. Derdy.—*Linearia arenaria*, and other British Plants: G. C. Druce.

FRIDAY, NOVEMBER 22.

PHYSICAL SOCIETY, at 5.—On Singing Sand from New England: S. Skinner.—Exhibition of a Micromanometer: L. Bairdston.—A Diabolo Experiment: Vernon Boys.—Exhibition of a Gyroscope illustrating Brennan's Monorailway: Prof. H. A. Wilson.

CONTENTS.

PAGE

A New Handbook of Inorganic Chemistry	25
Italian Birds and Neogenesis. By W. P. P.	25
Physiology of Alimentation. By W. D. H.	26
School Arithmetic. By F. L. G.	27
Our Book Shelf:—	
Petronievics: "Die typischen Geometrien und das Unendliche."—G. B. M.	28
Allen: "Engineering Workshop Practice"	28
Duncan: "Steam and other Engines"	29
Franklin and Macnutt: "The Elements of Mechanics. A Text-Book for Colleges and Technical Schools."—E. G. C.	29
Kuckuck: "Die Lösung des Problems der Uezeugung (Archigonia, Generatio spontanea)."—J. A. T.	29
Daniels: "The Flora of Columbia, Missouri, and Vicinity"	29
Duncan: "The Evolution of Matter, Life, and Mind"	30
Basforth: "Ballistic Experiments, from 1864 to 1880"	30
Letters to the Editor:—	
The Origin of Radium.—Dr. Otto Hahn	30
The Victoria Jubilee Technical Institute, Bombay.—Dr. Morris W. Travers, F.R.S.	31
November Meteors.—John R. Henry	31
An Optical Illusion. (<i>With Diagram</i>).—Dr. L. U. H. C. Wernly	31
The Interpretation of Mendelian Phenomena.—R. H. Lock	32
Method of Observing the "Subjective Yellow."—John H. Shaxby	32
Antarctic Animals. (<i>Illustrated</i>).	33
The Cure and Prevention of Sleeping Sickness	36
The Pollution of Rivers	36
Sir James Hector, F.R.S. By J. W. G.	37
Notes	38
Our Astronomical Column:—	
Occultation of Neptune by the Moon	42
The Improvement of Celestial Photographic Images	42
The Great Red Spot on Jupiter	42
Red Stars near Nova Velorum	42
The Systematic Error of Latitude observed with a Zenith Telescope	42
Inequalities in the Motion of the Moon	43
New Facts about the Arunta. By A. C. H.	44
University and Educational Intelligence	45
Societies and Academies	46
Diary of Societies	48

THURSDAY, NOVEMBER 21, 1907.

MODERN SCIENCE AND AMERICAN TECHNOLOGY.

The Chemistry of Commerce. A Simple Interpretation of some New Chemistry in its Relation to Modern Industry. By Robert Kennedy Duncan. Pp. x+263. (London and New York: Harper and Brothers, 1907.)

THE author of the book with this alliterative and not very apt title is a teacher of chemical technology in a university of one of the western States of North America. He appears to have spent a year's leave in Europe in making himself more or less familiar with certain manufacturing processes depending upon more or less recondite facts of modern chemistry, and he is constrained to publish what he has learnt in the hope of convincing the American manufacturer, in particular, that modern science is "absolutely applicable" to the economy and progress of his operations. He was the more encouraged to put forth the present attempt for the reason that, as he tells us, a former venture of his received "words of appreciation" from mining engineers in South Africa and school teachers in China, as well as from captains of the navy and captains of industry. From which we may infer that the professor of industrial chemistry at the University of Kansas, of whose literary productions we confess we were hitherto in complete ignorance, is in reality one of the most widely-read authors of his time.

The dozen chapters of which the book is made up are so many detached fragments, and from the fact that they have been copyrighted at different times during the last three years, they would seem to be reprints of magazine or newspaper articles. Their literary style is indeed characteristic of much of Transatlantic journalism. When the author seeks to be convincing he is merely turgid and inflated, and what he strives to gain by emphasis he loses in the effect which might have been secured by sober, accurate, and impartial statement. Perhaps, however, Mr. Duncan is the best judge of the appetite of the class for whom he caters. His own particular world of educated laymen intellectually eager to know of the advance of knowledge, who, we are parenthetically informed, "are not fools," may like to have what he calls their "pabulum" served up to them hot and strong, and with plenty of condiments. But in his attempts to whet that appetite the author at times comes perilously near to the "sensational misinformation" of which we gather "the other fellow" has been occasionally guilty. Whilst regretfully admitting that in his book "there does not inhere the romantic interest attached to radio-activity and the nature of the chemist's atom," he yet claims for it "the glorious interest that attaches to the doing of real things."

These extracts from the author's "foreword" are characteristic of the rest of the work. He has a passion for strong words, and his vocabulary is simply amazing. But unfortunately the words

occasionally prove too strong for him; they get beyond his control—carry him off his feet, as it were—and rush him into a labyrinth of phrases where he gets effectually lost.

But to a reader who is not over-fastidious as regards literary style, or whose sensitiveness has been dulled by daily perusal of the journalism of Kansas, there is much in this book to interest and amuse. To begin with, the reader will not be bored by too much theory. Theory, we perceive, is not the author's strong point, and he has little sympathy with it. To him "the doing of real things is the preferred work of the world." He never forgets that he is a professor of technology. Speculations on the why and wherefore are, of course, not wanted in the eager, pushful, strenuous life of young America—at least not in Kansas; and as for the question "Why is gold?" it is, we are told, as insoluble as the question "Why is a hen?"

"No man of science can justifiably make of himself an anchorite." Shades of Cavendish and Cayley! Our author remembers a brilliant young researcher who "told him that he had developed a wholly new chapter in mathematics. 'And the best of it is,' he said with a glow of enthusiasm, 'that it can be of no earthly use, either practical or theoretical!' Had that man passed observingly through the vicious purlieus of the Bowery or through the vast sordid stretches of East London, surely it would have struck home to him that his work was not only not right, that it was a crime."

Oh! Mathematics, Mathematics! What crimes are committed in thy name! Perhaps it is an acute consciousness of this that leads the man of Trinity or the "gentle Johnian" to prefer King's Cross as a mode of entry to London rather than gaze upon the vast sordid stretches through which Liverpool Street is reached, and which a too selfish devotion to "pure" mathematics leaves neglected and unrelieved.

The American manufacturer, we gather, is not over-sensitive. If he were, he would surely wince under what the author calls the "stings and arrows" which are hurled against him in this book. The general character of much of American technology, we are told, is summed up in the phrase, "Save at the spigot and waste at the bung." What pulls the manufacturers through, however, is "expert office management," "efficiency of exclusive control obtained through business intrigue," "huge and lying advertisements," combined with "gross adulteration of manufactured products." This is a fair sample of the author's "pretty way" of expressing himself, but as he is a professor of technology in America he ought to know what he is talking about when he deals with American technology, and we must suppose, therefore, that his strictures are merited. Certainly the evidence he affords of "the utter stupidity and ignorance displayed by glass-makers" (in America) in the chemistry of their manufacture is only less marvellous than the ingenuity they display in the complicated and efficient mechanisms—for the most part of American origin

and device—which are to be found in their glass factories. But perhaps, after all, this is only the author's method of adorning his tale and of pointing his moral—to enable him, in fact, to bring out in high relief, and by forcible contrast with this story of confusion and waste, how the science of glass-making is studied and practised at Jena.

"The romantic départment of the nitrogen atom"—due to a certain "temperamental nervousness" which sends it flying on the slightest pretext from one atomic community to another," is, he confesses, fascinatingly interesting, and this interest prompts him to follow the vagaries of this "labile element"—this "versatile restless nitrogen"—until it is caught and transformed into what he calls "Kaltstickstoff," whence it passes into carrots and potatoes. The story, as a story, loses nothing in the telling as told by Mr. Duncan, but the serious student who eagerly desires "to know the significant results of modern knowledge" will be saddened, but not made wiser, by the total lack of accurate statement of ascertained facts in connection with "the problem of the fixation of nitrogen and what man may do when he must," which constitutes the subject-matter of chapter iii.

America has recently grappled with the subject of industrial alcohol, and Mr. Duncan deals with the new departure in characteristic fashion. As regards the alcohols in general, "the one bearing the peculiarly graceful name of *Ethyl* is the flower of the sisterhood and the subject of chapter vii." In beginning to enumerate its properties, "it is embarrassingly plain" that its properties "are not in one bundle"; "it is the most perplexing substance with which man has ever had to deal"—"a perfect femininity of varying and conflicting properties" functioning "ubiquitously and contrariwise in the affairs of man." But chequered and dubious as is the reputation of "the flower of the sisterhood"—"the theme of poets, and contrariwise, the rage of publicists," this "angel-demon" is sweetness and purity when compared with "the wine of wood"—methyl alcohol—of which it appears some ten million gallons "have, yearly, been floating about America in various use."

"A not inconsiderable quantity of it is absorbed by the low negro populations of the country, who drink it under the appellation 'white horse' or 'old mule,' or by a pleasing mode of rhetorical transition, and in order, perhaps, to distinguish it from 'Ethyl,' as 'Maude.' Much of it again has appeared in 'witch hazel,' 'bay rum,' 'eau de Cologne,' 'Florida water,' essences, 'Jamaica ginger,' 'extract of lemon,' 'liniments,' patent medicine nostrums, and red ink. Poor and decadent people drink these things, and barring individual idiosyncrasies, whether it be a man in Indian Territory who drinks red ink, or a man in North Dakota who drinks 'Jamaica ginger,' there is apparently a fairly uniform result. Out of ten men who drink four ounces each of pure methyl alcohol in any form whatever, four will probably die, two of them becoming blind before death; the remaining six may recover, but of these two will probably be permanently blind. Even the absorption of its vapour through the lungs, or of the liquid through the skin, may produce permanent blindness. The 'hearings' before the Committee on Ways and

Means afford ample confirmation of this in the procession that filed before it of blind wrecks that had once been hat stiffeners, varnishers or shellackers, men who did not drink methyl alcohol, but who merely handled it as a solvent. The harm wrought by the substance has been greatly accentuated in the last few years by its manufacture and sale in a purified form, the so-called 'deodorized' methyl alcohol, whose smell gives no warning of its deadly nature."

Let the sporadic drinkers of methylated spirit in this country now take warning from this fearful recital of the risks they run. Perhaps, too, the users of industrial alcohol among us may congratulate themselves that the revenue authorities now require only half the former quantity of this pernicious substance to be used in "methylation." And perhaps, too, they may see some justification, in the interests of the community, for the maintenance of the present high duty on "potable" methyl alcohol. It was, of course, the relatively low price of this alcohol in America—70 cents as against 2 dollars and 8 cents for the taxed ethyl alcohol, that led to such a widespread substitution of the wood alcohol for the alcohol of fermentation.

What with the "whisky trust" "nobbling" the "wood naphtha trust," and the druggists forcing up the retail price of industrial alcohol to ninety cents a gallon—"a disgrace," says the author, "to commercial decency"—America is only at the beginning of her troubles in this matter, and there are already signs that the present regulations will have to be considerably modified if her manufacturers are to reap the full benefits of untaxed spirits.

The other chapters of the book deal with the industrial applications of catalysis; the use of the rare earths in illumination; the electric furnace, the manufacture of synthetic perfumes and of medicines; opsonins and inoculation, and the applications of cellulose. The last chapter gives an account of a scheme of industrial fellowships to be held in connection with a university which, like that of Kansas, enjoys the advantage of a department of applied chemistry, and the author illustrates its working by its application to the discovery of improvements in the chemistry of laundering, with the object of discovering "how the swift and progressive disintegration of the shirt" in the laundry may be arrested. Considering that the people of America pay a laundry bill of nearly twenty-five million dollars a week, Mr. Duncan thinks that a yearly subsidy of five hundred dollars, payable monthly to the holder of the fellowship for two years, in return for a comprehensive monograph on the chemistry of laundering, is the merest trifle in view of its bearing on the problem of the welfare of shirts. "What more can be desired by a young man at the threshold of his activity, even if it means that he must leave the 'nook merely monastic' of a professor in embryo for a life of industrial alarms and strenuous war?"

But this is only one of the many "exasperating, vitally important" problems which await solution at the hands of him who will combine the practical knowledge of the workshop with the special knowledge that awaits him in the class-rooms at Lawrence, Kansas, U.S.A.

THE PHILOSOPHY OF A BIOLOGIST.

Éléments de Philosophie biologique. By Félix le Dantec. Pp. iii+297. (Paris: F. Alcan, 1907.)

PROGRESS in knowledge takes place by the discovery of facts, and by drawing inferences from the facts discovered. It is commonly supposed that the facts existed before we discovered them; and this hypothesis stands the test of practical utility. But it is not supposed, except by the most careless thinkers, that the inferences which we draw from the facts—our laws and principles—are anything more than conceptual summaries of the facts and sequences of facts within our ken. (We use the word fact, not because in current usage it means that about which there can be no doubt, but because it includes a wider range of phenomena than the word "thing." The fact that 25 per cent. of the peas, produced by breeding from hybrids resulting from the union of a yellow and a green pea, are green can hardly be described as a "thing.") Our inferences may be right or they may be wrong, but they did not exist before we made them. Whether we can draw any sharp distinction between fact and inference; or, to put it in terms of space, whether we can draw a line of demarcation and say where fact ends and where inference begins, is a question which concerns the modern biologist perhaps more vitally than any other; yet it is one which very few have definitely formulated, much less attempted to answer. The cause of the almost universal failure to provide a satisfactory answer is a habit of the mind, encouraged by text-books of logic, which drives it to classify things, often dichotomously, into two mutually exclusive categories. Music affords an example. Some folk hold that the music of certain authors is good, whilst that of others is bad. Others, however, say that taste is a purely relative matter, and that no one has a right to say that the music of a given author is good, or bad, as the case may be.

The real truth is that whilst at one pole there are classes of music which are unquestionably good, that at the other there are types which are equally unquestionably bad; between the two there is a series of intermediate kinds about which it is debatable whether they are good or bad.

It is the same with fact and inference. At one pole there are undoubtedly things which can be classed as facts; at the other, things which cannot be claimed to be more than inference. But between the two there is a whole range of things which some regard as facts, whilst others regard them not only as inferences, but as unwarrantable ones. Biologists are far too much occupied with discovering facts and with drawing inferences to stop to consider the relation between these two processes. It is therefore with particular pleasure that we note the appearance of Prof. le Dantec's book, "*Éléments de Philosophie biologique*," at the present moment.

The book is divided into two main divisions, of which the first embraces the methods and the second the facts—an arrangement which, at first sight, appears natural, but which, on closer inspection, in our

opinion loses this feature. It seems, at first glance, natural that we should first describe the method of quarrying slate, and then dilate on the properties of the material brought to the surface by the machinery we have described. But in our opinion a truer picture of nature is conveyed by displaying the profusion and chaos of her phenomena first, and then tentatively enunciating the general conclusions we have ventured to draw from them afterwards. When we look closer at that part of Prof. le Dantec's book which deals with method, the temporary illusion of naturalness of arrangement completely vanishes; for an array of possibly true but extremely abstruse generalisations meets our eyes. The first chapter deals with the conceptions of "unity" and "diversity," which are surely not part of the equipment by means of which facts are brought to light, but some of the fruits which their discovery has borne.

But we do not wish to convey the impression that in our opinion the book is not a valuable one. It contains some much needed caution on the dangers of an unconscious anthropomorphism in the interpretation of nature, and on the dangers of, what is merely a result of that fallacy, a too premature attempt to analyse phenomena. But perhaps what makes the book more valuable than anything else is Prof. le Dantec's familiarity with the facts with which the science of pathology deals, a range of phenomena which more directly concerns, but is perhaps less heeded by, the student of evolution than any other.

THE HAMBURG EXPEDITION TO SOUTH-WESTERN AUSTRALIA.

Die Fauna Südwest-Australiens. Ergebnisse der Hamburger südwest-australischen Forschungsreise, 1905. Edited by Prof. W. Michaelsen and Dr. R. Hartmeyer. Vol. i., part i. Reisebericht by Prof. W. Michaelsen and Dr. R. Hartmeyer. Pp. viii+116; illustrated. (Jena: Gustav Fischer, 1907.) Price 4 marks.

THE zoological collections of the German South Polar Expedition to South Georgia in 1882-83 are preserved in the Natural History Museum at Hamburg, the staff of which therefrom acquired a special interest in the subantarctic fauna. On the renewal of Antarctic research, the Hamburg zoologists decided they could contribute most usefully to that work by continuing the investigation of the adjacent regions. The marine subantarctic fauna is most accessible on the western coasts of the three great southern continents, where its range is extended northward by cold ocean currents. The Hamburg Museum accordingly arranged zoological expeditions to each of these three areas. The first went to South America, and worked in the Straits of Magellan and along the western coasts of Chilian Patagonia; its collections have been described in a series of monographs issued from 1896 to 1907. The second expedition was led by Dr. Schultze to the coasts of south-western Africa, and the series was completed by the visit of Prof. Michaelsen and Dr. Hartmeyer to Westralia from June to October, 1905. They there made marine collections

in Shark's Bay, Champion Bay, Geographe Bay, and King George's Sound; they collected on land, especially around Perth, Geraldton, and Albany, and travelled inland as far eastward as Kalgoorlie. They describe the south-western part of Australia as zoologically "a forgotten corner," for as Westralia is younger and larger and has a smaller population than the Eastern States, it has not been able to organise such extensive studies of its fauna and flora.

The authors regard their expedition as very successful, and their scientific results are to be issued in a series of volumes, of which the part now published is only the general introduction. It describes the authors' journey, and gives a list, with a map of their collecting stations. It consists of two reports, one by Prof. Michaelsen, describing his general observations on the geography of Westralia, including its scenery, physiography, flora and fauna, and the aborigines. Dr. Hartmeyer contributes an account of the sheep-farming, the mining industry at Kalgoorlie, and of the dredging expeditions. Both essays give a pleasant account of the country in spite of sufferings from the ubiquitous Worcester sauce. They gratefully acknowledge the ready help of the officials and people. They remark the "extravagant" width of the Kalgoorlie streets, and the difficulties of railway administration on lines where, as Prof. Michaelsen expresses it, there is no fear of collisions. Their Shark's Bay boatman seems to be a typical Australian; "he speaks not much, but he understands his business, and what he does he does with hand and foot." The report contains interesting comparisons with other faunas. Thus Prof. Michaelsen, who had previously studied the zoology of Lake Baikal, contrasts the fauna of that very ancient, perhaps pre-Devonian, deep lake, with the life of the recent, shallow pools of Western Australia.

The most generally interesting zoological result given is probably Prof. Michaelsen's conclusion as to the relations of eastern and western Australia as indicated by the earthworms (pp. 49-50). He holds that since the appearance of the ancient genus *Plutellus*, south-western Australia has been united by land only to the eastern States. There are no affinities to other lands, which are not also common to eastern Australia. Comparatively few foreign earthworms entered eastern Australia, and they arrived at different dates, and crossed subsequently into south-western Australia. There they developed into distinct though closely allied species, probably at a time when the land extended farther south-westward in separate peninsulas or had been temporarily divided into islands, which gave the worms on them complete though temporary isolation.

As the authors' journey was naturally confined to the best known areas in Westralia, there was not much opportunity for obtaining new geographical information, and the value of the work of the expedition will depend on the technical and biological memoirs which are to follow. This preliminary account gives evidence of such thorough and careful work, that important results may be expected from the work of two such skilled zoological experts.

J. W. G.

NO. 1986, VOL. 77]

OUR BOOK SHELF.

Experimental and Theoretical Applications of Thermodynamics to Chemistry. By Dr. Walther Nernst. Pp. x+123. (London: A. Constable and Co., Ltd., 1907.) Price 5s. net.

Technische Anwendungen der physikalischen Chemie. By Dr. Kurt Arndt. Pp. vii+304. (Berlin: Mayer and Müller, 1907.) Price 7 marks.

THE first of the above volumes contains a series of ten lectures delivered by Prof. Nernst at the Yale University in 1906 under the Silliman Foundation. After two introductory chapters, a *résumé* is given of the experimental investigations which have been carried out by the author and his students on chemical equilibria at high temperatures. In a theoretical discussion of the results, the author develops the view that relationships exist between chemical energy and heat other than those expressed by the first and second laws of thermodynamics. From a consideration of the conditions under which the principle of Berthelot comes nearest to expressing the true relation between heat and chemical energy, the conclusion is drawn that the total and free energies are not only exactly equal at absolute zero, but that their values coincide completely in the vicinity of this temperature. In the last three chapters the practical application of the integrated equation of the reaction isochore is illustrated by calculation of the equilibrium in various dissociating systems at high temperatures, such as water vapour, nitric oxide, hydrogen chloride, carbon dioxide, and metal ammonia compounds.

Whether the reader is interested in the fundamental theoretical speculations or the practical application of the derived formulæ, Prof. Nernst's series of lectures cannot be too warmly recommended.

In his "Technische Anwendungen" Dr. Arndt presents an account of certain chapters of physical chemistry and of recent investigations which have an important bearing upon technical processes. The volume does not make any pretence to be a complete treatise on the subject, but carefully chosen examples of the application of physico-chemical principles to industrial processes are discussed in considerable detail. In the first three chapters the formation of nitric oxide from air, the equilibrium in the manufacture of generator and water gas, the manufacture of sulphuric acid by the contact process, the formation of ammonia and of ozone are dealt with, the remaining ten chapters being devoted to a less detailed consideration of catalysts, changes of state, solutions, alloys, dissociation pressures, and the measurement of high temperatures.

The book is distinctly worthy of attention, has many good features, and contains a lot of useful references, although the author—if one may judge from the very small number of references to English chemical literature—does not appear to be very familiar with work carried out in this country. This is an unfortunate circumstance, and detracts not a little from the value of the book.

H. M. D.

Die Auszeichnungsrechnung nach der Methode der kleinsten Quadrate. By F. R. Helmert. Second edition. Pp. xviii+578. (Leipzig and Berlin: B. G. Teubner, 1907.) Price 16 marks.

THE principal changes in this new edition consist in the more detailed discussion of errors of observation, instrumental corrections, interpolation problems, and the reduction of triangulations. The last chapter deals with the choice of favourable conditions in various surveying problems. In its present form the work appears to be admirably suited for those who have to make practical use of the theory of errors, especially

surveyors and astronomers. The examples are mostly taken from actual observations, and the necessary calculations are given in considerable detail. In the earlier chapters a knowledge of determinants is not assumed, and the explanations given ought to make the method intelligible to readers of quite moderate mathematical ability. For the more difficult and controversial points of the theory, reference is made to the treatise of Czuber; at the same time, a very good example of the unavoidably empirical nature of the whole subject is given by working out the same elementary problem according to each of three different laws of error. Now that the measurements of physics and chemistry are approaching, not to say surpassing, in exactness those of astronomy and geodesy, a practical work of this kind is likely to assist a larger and larger body of experimenters.

Die Purbakterien. Eine mikrobiologische Studie. By Prof. Hans Molisch. Pp. 92. (Jena: Gustav Fischer, 1907.) Price 5 marks.

This memoir deals with an interesting group of chromogenic microorganisms, viz. those producing brilliant pigments ranging in tint from pink, through rose and deep red to reddish-purple. They are probably more nearly allied to the coloured algae (Phycchromaceæ) than to the bacteria proper, and one of the earliest descriptions of a member of the group was given by Sir Ray Lankester in 1873 under the title of a "peach-coloured bacterium." The author first discusses the occurrence in nature of these organisms. Sometimes they are met with in great abundance on the sea-coast, in river estuaries, and in hot and sulphur springs. Directions are given for obtaining growths in various organic mixtures, for the preparation of suitable culture media, and for obtaining pure cultures in the latter. The biological and physiological properties are next considered; while light has an inhibitory, or a germicidal, action on most bacteria, the "purple" bacteria develop best in its presence. They are sensitive to all light rays, but in particular to the ultra-violet ones; they do not, however, evolve oxygen in the presence of light, and their need for oxygen varies much, some species being almost anaerobic.

The colouring matter produced by the "purple" bacteria is a mixture of two pigments—a green, "bacteriochlorin," and a red, "bacteriopurpurin." The chemical and other properties of these are described fully.

As regards classification, the organisms are grouped in a special order, the Rhodobacteria. This is divided into two families, distinguished by the presence or absence of sulphur granules, and several new species isolated by the author are described. Altogether the book forms a very useful summary of our knowledge of an interesting and peculiar group of microorganisms.

R. T. HEWLETT.

The Case of Existence. By Norman Alliston. Pp. xiii+262. (London: Kegan Paul, Trench, Trübner and Co., Ltd., 1907.) Price 5s. net.

"Of the enigmas of life," says Mr. Alliston in his introduction, "all speak; but nobody asks as if there were an enigma." It is his object to remove this inconsistency by exposing the confusions of thought of those who "want life speculatively to be a mystery." The book has three parts. The first contains a good account of the nature of Explanation and some not ineffective criticisms of Knowledge, Nature, &c., mingled, it must be admitted, with much rather ill-informed dogmatism. The second, in the course of a review of man's "obstinate questionings" about existence, develops the author's peculiar egotistical optimism. The third, in which he draws his ethical

corollaries, unfortunately contains some chapters which many readers will find offensive both in matter and in tone. The book contains little to engage the attention of the practised student of philosophy, but, being written with obvious conviction and enthusiasm, may here and there attract a useful recruit to the study of first principles. At a later stage the student may not unprofitably return to these pages to detect and analyse the crudities and ambiguities which abound under a surface of apparent lucidity.

Science German Course. By C. W. P. Moffatt. Pp. xii+228. (London: W. B. Clive.) Price 3s. 6d.

The portion of this book devoted to grammatical construction and word formation occupies about eighty pages, and is followed by extracts for translation from the German. These selections deal with various scientific subjects, and can be commenced after the student has made himself familiar with the first few pages of the grammar that precedes them. Short vocabularies are given of technical terms in mathematics, physics, chemistry, geology, botany, and zoology. The book thus provides a convenient means of obtaining sufficient acquaintance with the German language to read simple scientific descriptions in it with intelligence.

LETTERS TO THE EDITOR.

[The Editor does not hold himself responsible for opinions expressed by his correspondents. Neither can he undertake to return, or to correspond with the writers of, rejected manuscripts intended for this or any other part of NATURE. No notice is taken of anonymous communications.]

The Wehnelt Kathode in a High Vacuum.

THAT a good vacuum can be made into a good conductor by the use of an incandescent kathode is known since the discovery of the Edison effect, and has been investigated with great thoroughness by O. W. Richardson (Trans. Roy. Soc., 1903, 201 A, 497). Wehnelt has shown (*Ann. d. Physik*, 1904, iv., 14, 425) that if the incandescent kathode is coated with one of the alkaline earths, surprising results can be obtained. From a platinum foil kathode at 1300° C. to 1400° C. coated with lime, two to three amperes per sq. cm. of surface can be passed through a good vacuum, the kathode fall being practically negligible, and the total voltage across the vacuum tube being below 30 volts. This result is so very remarkable that I have repeated it in the following way to test whether, as is commonly supposed, the phenomenon is really independent of the perfection of the vacuum.

In a tube provided with a Wehnelt kathode of about a sq. cm. area was mounted an anode of the metal calcium. I have recently shown (Proc. Roy. Soc., 1907, 78 A, 429) that calcium at its volatilising temperature (700° C. to 800° C.) absorbs practically instantaneously and very perfectly all known gases and vapours except the chemically inert gases of the argon family, and has described a form of vacuum furnace suitable for this operation. The tube was prepared in the usual way by preliminary exhaustion and washing out with oxygen to remove argon, and then subjected to the action of calcium heated in a furnace attached to the apparatus. When a good vacuum had been obtained, current from the 250-volt supply was passed through the tube between the heated Wehnelt kathode and the calcium anode in order to heat the latter.

The gases evolved from the anode and tube under this treatment were absorbed by the calcium in the furnace. The current was regulated by a resistance to about 1.2 amperes, and was interrupted at intervals to give the evolved gases time to flow out of the apparatus. When the gases had been for the most part removed the current was passed continuously, heating the calcium anode up to its volatilising point. Quite suddenly and completely the current through the tube stopped, and at the same moment a copious mirror of calcium was volatilised from the anode. In a little while a very feeble glow started and passed

intermittently from time to time, but it was not enough to move the ammeter needle, and was most likely due to a further slow evolution of gas from the still heated surfaces. A current could be passed by a coil from the hot kathode to a third electrode as anode without causing any appreciable resumption of the flow in the 250-volt circuit.

More gas was then generated within the apparatus by heating the third electrode with the coil discharge, and the current in the main circuit resumed its original intensity, again heating up the calcium anode. The original phenomenon was repeated, a sudden cessation of current taking place when the calcium volatilised. Just before stopping, the glow of the tube changed to that characteristic of argon, so probably a trace of air had not been removed. The whole phenomenon could be repeated by admitting oxygen to the apparatus and proceeding as before.

This experiment shows that in a sufficiently high vacuum the Wehnelt electrode ceases to be effective. In the experiments so far recorded the saturation current has increased with the improvement of the vacuum, and the phenomenon has been supposed to be in the first place independent of the residual trace of gas present. Wehnelt (*loc. cit.*, p. 445) remarks:—"Für Drucke unter 0.1 mm ist die für eine bestimmte Temperatur ausgedante Zahl von negativen Ionen unabhängig vom Druck," and (p. 456) "die Grenzstromstärken um so höher sein . . . je tiefer die Druck ist." In his description of his modification of the Braun tube (*Phys. Zeit.*, 1905, vi., 732) he says the vacuum in the tube must be as perfect as possible.

Richardson, whose mathematical theory of the general phenomenon has received quantitative experimental confirmation, and has been accepted by Wehnelt in the case of his electrode, regarded the action as purely electronic. Commenting on the magnitude of the current and the smallness of the residual gas—in one experiment a ampere per sq. cm. at a measured pressure of 0.0016 mm. from a carbon lamp-filament—he says (*loc. cit.*, p. 546):—"This (the current) is twenty-five times the maximum value obtained by supposing each molecule to produce one ion; so that it is highly improbable that any considerable part of the conductivity investigated is due to ions produced in this way. . . . Both these points of view lead to the conclusion that the corpuscles are not produced by a dynamical action between the molecules of the surrounding gas and the surface of the metal. In fact, all the experimental results seem to point to the view that the corpuscles are produced from the metal by a process similar to evaporation."

These isolated quotations, of course, may not fairly express the opinions of the authors about what is a very complex phenomenon; but the general impression their results has conveyed, I think, has been that the large currents dealt with were wholly conveyed by the expelled electrons, and therefore should pass through any vacuum, however perfect. I do not think the electronic emission can account for more than a negligible fraction of the total current, which is carried almost wholly by the residual gas.

The results here given bear out the general view I have from time to time advocated since my experience with the use of calcium, that degrees of vacuum are in practice apt to be overrated, and really high degrees of vacuum are not so readily obtained as is commonly supposed.

FREDERICK SODDY.

Physical Chemistry Laboratory, The University,
Glasgow.

The Interpretation of Mendelian Phenomena.

I AM strongly inclined to agree with Dr. Archdall Reid that Mendelian investigations throw no light on many of the most important problems of biology, such as the causes of variation, the evolution of adaptations, and many others. On the other hand, it is difficult to understand what Dr. Archdall Reid means by the statement that Mendelism is the investigation of sex. In one of his letters he describes Mendelian phenomena as "abnormalities of sexual reproduction which occur under conditions of artificial selection." If this means peculiarities of

heredity in sexual reproduction observed in cultivated varieties, it may be allowed to pass; but in an appendix to the second edition of his "Principles of Heredity," Dr. Reid states that the inheritance of Mendelian characters is probably sexual. He proceeds as follows:—"Nature has evolved alternative inheritance to create and perpetuate sexual differentiation, but, just as blending of sexual characters sometimes occurs, so on the other hand the inheritance of non-sexual characters is sometimes alternative. As we have seen, whenever the latter happens, the non-sexual differences are, like the sexual differences, usually considerable. Nature makes the mistake, so to speak, of treating them as sexual. Of course, however, the alternative inheritance of large non-sexual differences is not certain, not so 'clean' as that of sexual differences, the alternative inheritance of which has been established by a long course of selection."

According to this, the alternative inheritance of non-sexual characters is of the same nature as sexual dimorphism. It seems to me that Dr. Reid has not sufficiently studied the inheritance of secondary sexual characters. It is admitted by almost all evolutionists from Darwin himself downwards that selection cannot have been the cause of the alternative inheritance of sexual differences. The female in selecting a particular male cannot prevent the transmission of his peculiarities to her daughters. The male characters must be limited to the male sex from their first origin as variations, because otherwise the selection of the individual male would merely ensure their transmission to both sexes.

The essential peculiarity of secondary sexual characters is their physiological connection with the primary, *i.e.* with the male or female gonads. It is not merely a question of alternative inheritance; both male and female characters are inherited by each individual, but normally only one set is developed. When, however, the male gonads are removed, the male characters are usually not normally developed, but suppressed. In Mendelian cases the development of alternative characters is usually entirely independent, both in theory and fact, of the sex or condition of the gonads.

The contrast of male and female corresponds to alternative dominance in a heterozygote; male characters are dominant in male, female in female, but either can and does transmit both. In Mendelian cases alternative inheritance is segregative; a recessive transmits only recessive characters, a pure dominant only the dominant. In other passages which I could quote Dr. Reid has shown that he has failed to appreciate this fundamental distinction between dominance and segregation, between the heterozygote and the homozygote, between the first generation of a Mendelian cross and the second.

Excepting parthenogenesis, the heredity of all characters is sexual in that it is connected with fertilisation, but I do not see that Mendelian characters are sexual in any other sense. The theory that the inheritance of sexual characters is Mendelian is one which has a definite meaning and can be investigated. Dr. Archdall Reid's statement that Mendelian inheritance is sexual is in one sense a truism, in another seems to me to have no real meaning at all, for to say that nature has evolved alternative inheritance to perpetuate sexual differentiation explains nothing.

J. T. CUNNINGHAM.

Hillegate, November 3.

I AM very willing, and, like most people with theories, I believe I am able to maintain the correctness of the views to which Mr. Cunningham refers; but to discuss my speculations now would be to confuse the issue. I may say, however, that the appendix to the second edition of my work, from which Mr. Cunningham quotes, is a mere sketch hastily thrown together to meet the objections of critics who had advised the lay and scientific public that a book, which I fondly hoped contained a little that was new, and which certainly contained more than a little of which Mendelians seem profoundly unaware, was antiquated and worthless, not because there were no new facts or inferences in it, nor because its facts and inferences were invalid, but simply and solely because I had not adopted "the new method" nor accepted the

"new views," nor limited myself to matters which came within the range of the "new science." The criterion of merit struck me as highly remarkable and certainly very new, and indicative of a degree of toleration which, if not altogether new, is at least unusual amongst men of science. The passage quoted by Mr. Cunningham demonstrates that I expressed myself very badly. Soon, however, I shall have an opportunity of trying to do better, and I suggest that until then Mr. Cunningham shall suspend judgment.

In previous communications to NATURE I have admitted that Mendelism may conceivably shed a light on the function of sex, but I challenged its exponents to mention a single other problem on which it has the remotest bearing. No one has as yet mentioned another problem, and Mr. Cunningham denies, apparently, that it has a bearing on that of sex. Must we assume, then, that it sheds no light on anything at all?

If, instead of dwelling on the dangers incurred by those who venture to differ from Darwin, Mr. Lock (November 14) demonstrated my errors, he would be more convincing; and, since he is probably the only human being who doubts the blending of the black and white races in Mulattoes and their descendants, it would be well if he, rather than I, undertook the collection of pedigrees. He would feel himself on the track of a great discovery which would enlighten even Mulattoes, whereas I should feel I was wasting time. I do not know what I can gain from the renewed study which he is good enough to suggest. I am well aware of the three principal Mendelian doctrines—segregation of units, independent inheritance of characters, Mendel's law is the greatest of biological discoveries—and the more I see and read the more thoroughly I am convinced that they are all demonstrably erroneous, and that nothing but the restricted area covered by Mendelian studies has prevented a recognition of that fact by Mendelians themselves.

According to selectionists blending is the function, or at least the effect of conjugation. According to Mendelians, not blending, but segregation, occurs. Taken by itself, this doctrine assigns no function to conjugation; it merely controverts the theory of blending. Taken in conjunction with the Mendelian hypothesis of the independent inheritance of characters, it assigns to conjugation the function of effecting an exchange of units between the paternal and maternal sets of allelomorphs. That much the Mendelian doctrines imply—that much and no more. Clearly, then, Mendelism is concerned solely with the function of sex. At any rate, I can conceive of nothing else, and, judging from their spoken and written communications, Mendelians have been so rapt in contemplation of the grandeur of the discovery that they have given no further thought to the matter.

"But everybody said," quoth he,
"That 'twas a famous victory."

Mr. Lock declares that, since conjugation is nearly universal, all, or nearly all, the questions of heredity are problems of the function of sex. He might as reasonably argue that, since assimilation and death are universal, all problems of heredity are problems of assimilation and death. The looseness of thought which pervades Mendelism is well illustrated by his remarks on parthenogenesis and bud-variation. Mendelian segregation implies the separation of allelomorphs which, through the union of two gametes, have previously met in a zygote. There can be no meeting, and therefore no separation when reproduction is parthenogenetic. Mr. Lock, in fact, enunciates the surprising doctrine that all variation is Mendelian segregation. I hope he will forgive the bluntness of the expression, but he trifles with established terms.

Southsea, November 17. G. ARCHDALL REID.

The Winding of Rivers in Plains.

SIR OLIVER LODGE'S letter in NATURE of November 7 is itself an illustration of his comment on the way in which misunderstanding of cause may lead to misrepresentation of fact. The statements quoted by him are, as is often the case in text-books, inaccurate in so far as they are incomplete, but, nevertheless, in closer accordance with the

facts of nature, viewed from the geological point of view, than he supposes.

We are not dependent on the calculations of mathematicians for our knowledge of the behaviour of rivers; at one time I had a goodly collection of notes of observations made and published by others, but having unfortunately lost this, I shall write only of what I have seen myself, having had many opportunities of observing the behaviour of rivers which are subject to large variations of flow. In the dry season, when the water is low and the stream flows quietly in a channel of more than sufficient size to carry the discharge, I have noticed that the current is often perceptibly more rapid over the shallow water on the inner side of the bend than in the deep channel on the outer. The line of maximum velocity of flow would, consequently, lie nearer the inner than the outer side of the bend, and be less sinuous than the general course of the river, in accordance with the investigation quoted by Sir Oliver Lodge; but at these times the geological activity of the stream is so small as to be almost negligible. When, on the other hand, the same stream is in flood, and a day's work is more than that of a decade or a century of the placid flow, another state of things prevails; then the current sweeps rapidly round the outer side of the curve, and on the inner side is comparatively slack water. The line of maximum velocity must, therefore, become more sinuous than the river itself, and not only is this result to be reached by deduction, but in some cases it has been visibly perceptible. Further, the undertow on the outer edge of the curve has not been visibly distinguishable in any case that I have seen; if existing, its effect must have been insignificant in comparison with that of the horizontal movement of the stream, and often it certainly does not exist. At times, and in certain circumstances, sand and even pebbles may be thrown up to the surface of the water near the outer bank of the stream, and where the waters have overflowed the banks pebbles may be found lying on the dry ground after the flood has passed away; these facts show that there must, in some cases at least, be an upward, not a downward, current along the bed on the outer side of the bend of a stream.

Do not let me be misunderstood. So far as Sir Oliver Lodge is pleading for accuracy in text-books we are all with him, but when he states, as a positive fact, that the line of maximum velocity of current in a river is less sinuous than the river itself, and that the current along the outer bank of a curve is more rapid than along the inner, then I must join issue with him and maintain that these statements are only sometimes true. This is no question of the accuracy of Prof. James Thomson's calculations, but they evidently cover only that part of the problem which is least important from a geological point of view.

R. D. OLDHAM.

"Magic Mirror" Effects.

I HAD occasion recently to coat with collodion a silver surface mirror on patent plate 2 millimetres thick. During the operation the mirror was held with one of the rubber pneumatic holders frequently used by photographers when coating or varnishing plates. As the film of collodion set, a series of interference colours disposed in concentric circles appeared immediately over the region of the suction disc of the holder. I could scarcely bring myself to encourage the idea which at once occurred to me, viz. that the slight suction of the pneumatic holder was actually deforming so thick a plate of glass and producing an appreciable concavity in its vicinity.

But this seems really to have been the case. For when the beam of light from a lantern (placed with its back to the screen) was reflected back on to the screen by the mirror held with the pneumatic holder, there appeared in the rectangular patch of light determined by the size and shape of the mirror a much brighter internal circular patch which changed its position conformably with any alteration of the position of the pneumatic holder.

I have never seen any reference made to deformations produced in this way; yet such deformations might be found to have a practical significance in critical coating operations where absolute uniformity in the thickness of the coating is desired.

DOUGLAS CARNEGIE.

NOTES ON ANCIENT BRITISH MONUMENTS.

I.

SINCE the publication of my book "Stonehenge" some months ago I have received so much valuable information, so many suggestions and promises of work, that I feel it will be convenient if I refer to some of the points which have been thus raised. They refer to many sides of the inquiry, and indicate how very many questions susceptible of local study are raised by the idea of the possible astronomical use of the monuments.

It is only right, however, that I should state *in limine* that the reviews of the book have been almost entirely condemnatory. I am consoled, however, by the fact that there is evidence that the volume had not been read, and that the reviewers have taken so little trouble to inform themselves that they confound the changes brought about in the places of stars by the precession of the equinoxes with those produced in the case of the sun in conse-

quence of the gradual lessening of the obliquity of the ecliptic.

The Inter-relation of Monuments.

In my "Notes on Stonehenge" (NATURE, vol. lxxi., p. 391) I referred to some remarkable relations between Stonehenge and the surrounding localities which had been communicated to me by Colonel Johnston, the late director-general of the Ordnance Survey. These are rendered manifest by the accompanying diagrams which I reproduce.

Fig. 1 shows that Stonehenge is (1) on the same straight line which contains Sidbury, Grovely Castle and Castle Ditches; (2) at the apex of an equilateral triangle of exactly six miles in the side; (3) that Salisbury, *i.e.* Salisbury Cathedral, from its name an old solar temple, was on the same straight line which contained Stonehenge and Old Sarum.

Fig. 2 shows that the oldest cross-roads on Salisbury Plain exactly occupy the centre of the triangle referred to.



FIG. 1.

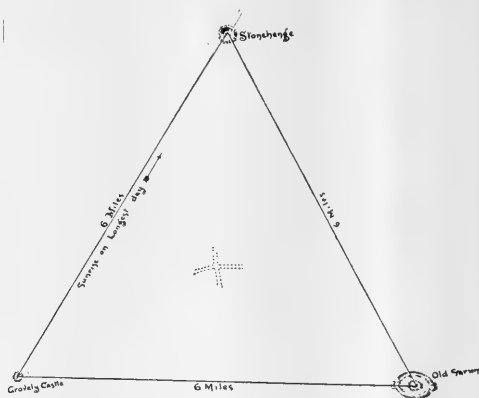

FIG. 2.

quence of the gradual lessening of the obliquity of the ecliptic.

Ignoring all the new observations the statement of which was the object of the book, they condemn what they are pleased to call my *theory*, as if a theory were anything but an attempt—even if only a feeble one—to group facts together so that they may be properly understood, and rigid tests applied to it by further work. It is a supreme satisfaction to me to know that further work is going on. Societies for the "Astronomical Study of Ancient Monuments" have been started in Cornwall and Wales, and local inquiries of great value are being made. I am glad to say that these efforts are being sympathetically aided by the existing archaeological societies, which, I think, have much to gain by the constant companionship of the spade and theodolite. I also have spent some holiday time in Cornwall, Wales, and Aberdeenshire, adding a special study of cromlechs to the inquiry. What I have previously written concerning the May-year is greatly strengthened by the fact that most of the cromlechs I have examined were constructed so

Such relations as the above, but on a smaller scale, are often to be noticed, in some cases between monuments, in others between monuments and decided natural features on the sky line as seen from them.

I give some examples from Cornwall.

At Trevehy is one of the most famous cromlechs in that county, and it has not been *restored*, so that we need not hesitate to measure it to try to determine its meaning. Close by, at St. Cleer, is a renowned holy well, and a little further away King Doniert's stone.

The accompanying photographic reduction of the Ordnance map shows the strict relation of these monuments. The entrance of the cromlech is directed towards the November sunrise, *az.* S. 63° E.; looking in the opposite direction it commands the May sunset. I shall refer to this later. As seen from the holy well the cromlech marks the azimuth of the May sunrise. The monolith, King Doniert's stone, is true west from the cromlech, and so marks the equinoctial sunsets.

In the Bodmin district are two famous circles, the Stripple stones and Trippet stones, some half-mile apart.

The following table shows the relation of the latter to the former, and also to the surrounding hill-tops, as I believe was first noticed by Mr. A. L. Lewis.

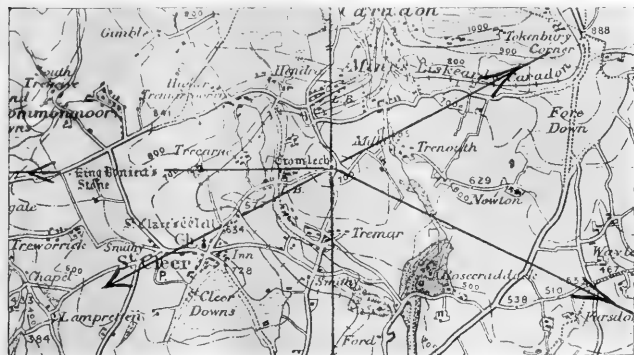

FIG. 3.—The inter-relation of the monuments near Liskeard.

We indeed learn why the circle was erected on the precise spot it occupies.

Trippet Stones, Blisland, lat. 50° 33' N.

	Az.	Hill	Dec.	Star	Date
To Stripple Stones.	N. 81° 30' E.	2'	N. 6° 42'	Pleiades	1720 B.C.
" Rough Tor ...	N. 15° E.	14'	N. 39° 1'	Arcturus	1700 B.C.
" Brown Willy ...	N. 31° E.	13'	N. 34° 5'	Capella	1420 B.C.
" Hawks Tor ...	N. 63° E.	23'	N. 18° 34'	May Sun	May 14.
" Barrow ...	S. 63° E.	assumed	S. 19° 31'	Nov. Sun	Nov. 21.

My wife and I visited the Trippet stones in April, 1907, in the company of Mr. Horton Bolitho and Mr. Collings. A hail-storm made observations difficult, and this may explain the departure of the May and November days from the normal. The coincidence of the dates of the possible observations of Arcturus and Capella suggests that we have then the true date of the erecting of the circle, Brown Willy being subsequently used with Capella when the old alignment of Arcturus on Rough Tor became useless in consequence of the precessional movement.

I shall have more to say on the inter-relation of monuments and double and multiple circles on a future occasion.

Ancient Connection between Stonehenge and Grovely.

Figs. 1 and 2 suffice to show the old association between Stonehenge and Grovely. Canon Wordsworth, in a paper on "Grovely Customs," communicated to the annual meeting of the Wiltshire Archaeological Society held in July, 1906, at Wilton, has brought together some additional particulars

touching this | have had, or should time out of mind have, yearly brought unto them against every Whit Sunday by the Ranger or his assigns, one fat Buck, the one half to

ing of wood in the valleys near Stonehenge; this, I think, may be accepted as strengthening the evidence that the plain at Stonehenge was not wooded, contrary to the opinions of many that the monument was built in a sacred grove of oaks. My argument against this view was that if the monuments had any astronomical use at Stonehenge, Dartmoor, or elsewhere, they would not have been erected among trees, which would have spoiled the observations which were always made on the horizon.

Next, in support of my view that Stonehenge was initially a May-year temple, the celebrations referred to by Canon Wordsworth occur in May. He recalled an extract from a paper written by Mr. J. N. Powell, on "South Wilts in Romano-British Times," in which the writer approached the subject from the point of view of the folklorist and student of primitive religion. Mr. Powell said:—"At Wishford an oak bush is cut annually, formerly at Whitsuntide, but since the Restoration on May 29, and hauled down into the village. It is then decked with ribbons and hung from the church tower, and the day is kept as a revel." Canon Wordsworth said that, if he rightly understood his drift, he supposed that that symbol of the villagers' right to gather wood, and in olden times also to pasture cattle in Grovely Forest, was associated with, or found its expression in, a ceremony of prehistoric cult or nature-worship. He then read a number of extracts from documents lent by the Rector of Wishford, the Rev. F. W. Macdonald, amongst which were the following:—"The aforesaid lords, freeholders and tenants of Barford St. Martin,



FIG. 4.—The Trevelty Cromlech.

Some of the new information refers to the gather-

Wishford and the other to Barford, to make merry withal amongst the neighbours. And the Ranger is to have from each of the Manors of Wishford and Barford one white loaf and one gallon of beer and a pair of gloves, or twelve pence in money for the whole, and if the Ranger do not bring nor send the fat Buck then the inhabitants of any of the said Manors or any of them, after that day may go into the said forest and kill and bring away a Buck for each of the said parishes at their pleasure, and then the Ranger is not to have anything." "The custom is and ever time out of mind hath been, that the lords and freeholders of Wishford Magna, and Barford St. Martin, and their tenants, by themselves, their servants and assigns, may take and fetch in the woods of Grovely, speeke rods (probably spicks or spars for use in thatching) and breeding rods, for their houses standing in the said manors of Wishford and Barford, and also fowl shoars (stakes for supporting hurdles) and wreeths (long rods for turning into hurdles) to be employed within the said manors at all times without controulment, and every one of the said lords and tenants that do use to fetch such ought to give the Ranger one hen yearly if he require and send for the same." "The ancient custom is that at all Courts holden for Grovely the Jury and Homage for the said forest hath ever been made, and in Right ought still to be made, of the freeholders, tenants, or inhabitants of Wishford Magna, or Barford St. Martin aforesaid and of none other."

Among the entries in the Rector's book is the following:—"Whereas the lord of the manor and parishioners of the parish of Wishford aforesaid did time immemorial use and enjoy laudable custom yearly in the month of May to cut down and carry away boughs of trees growing in the Chase of Grovely in the said county of Wilts (being part of the estate of the Earls of Pembroke) therewith to adorn the said Church of Wishford, and whereas the right honourable Philip, late Earl of Pembroke (probably seventh Earl, 1647-83), finding that the said usage and entry on the said Chase in the said month of May was a prejudice to his deer in that Chase, it being about fawning time, Did come to an agreement with the said Richard Howe, lord of the said manor of Wishford, and the parishioners of the said parish, and did grant to the said parishioners an annual rent charge in fee simple of six pounds a year issuing out of a meadow called Burdenball Meadow in the parish of Wilton in the said county of Wilts. And whereas the said rent of six pounds has been much in arrear and the right honourable Thomas, now Earl of Pembroke (Thomas Herbert, 8th Earl of Pembroke 1683-1733, Lord High Admiral 1702-1708, Lieut. of Ireland 1707), hath agreed with the said lord of the said manor and parishioners to give them the sum of 260*l.* of lawful money of Great Britain, in case they would release their right of the said rent of six pounds of the arrears."

Here we see how dates are changed, and we get a new reason for the abolition of an ancient custom. But this is not all. There is a suggestion of the old stone worship at Salisbury, the spire of which, as we have seen, is exactly in the line Stonehenge-Old Sarum prolonged.

"The lords, freeholders, tenants and inhabitants of the Manor of Great Wishford, or so many of them as would, in ancient time have used to go in a dance to the Cathedral Church of our Blessed Lady in the city of New Sarum on Whit-Tuesday in the said County of Wilts and there made their Claim to their custom in the forest of Grovely in these words, 'Grovely! Grovely!! and All Grovely!!!'" With reference to the last extract, Canon Words-

worth remarked that the dance to the Mother Church of Salisbury might have been connected with the procession to pay chimney-money, "smoke-farthings," or Pentecostal oblations. But after the Restoration of Church and King in 1660 the date was changed to May 29 in connection with the annual thanksgiving then instituted. The custom was kept up until the beginning of the nineteenth century. The last survivor who took part in it died in 1891, in her eighty-eighth year, and she described it to Mr. Hill (the rector in 1885) as a regular revel, with booths and shows erected in the Close. It was therefore suppressed, but still two women, as a deputation from the bough-bearers, went in with oak branches, which they reverently laid on the altar of the Cathedral Church. The last person who performed this ceremony died so lately as 1853. The people taking part in the procession used to dress in white, and they assembled first at Townsend's Tree, at the south end of the village street. They still in 1885 carried oak boughs in procession, but only as far as the Rectory, and performed their dance there.

Cheap and Handy Instruments.

Undoubtedly for final observations at any monument a theodolite must be employed, using the sun or Polaris in order to avoid all magnetic difficulties, and reversing the telescope to secure the correct altitude of the horizon.

But for rapid surveys there are many handy forms of instrument by means of which preliminary informa-

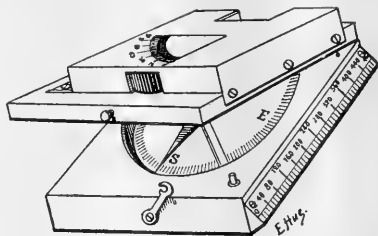

FIG. 5.—M. Hue's combined compass and clinometer.

tion can be gathered, both with regard to azimuth and, what is equally important, the angular height of the horizon. In a reconnaissance lately among the Aberdeen circles I employed a clino-compass of Barker's pattern; this weighs only a few ounces and is carried in a sling over the shoulders; even a tripod can be dispensed with, though it is much better to have one; the lightest form is that used by the Kodak Company for their cameras. In the clino-compass, as the name implies, both azimuths and altitudes are measured by the same instrument, the level being replaced by a pendulum; in this form, especially in the case of the altitudes, the mean of several observations should be taken. In my opinion, a desideratum for such work is a simple small instrument with level and reversible telescope for small altitudes only—a miniature dumpy level, fitting on to the same tripod which carries the azimuth compass.

We learn from the "Manual of Prehistoric Researches" published by the Société préhistorique de France that the French archaeologists are much more thorough and philosophical in their inquiries than their British brethren. It is not a question of the spade *versus* the theodolite, but of the spade *and* the

theodolite, and as full instructions are given about one as about the other.

It is quite refreshing to read the chapter "Indications pour faire un levé de Terrain à la Boussole," and then the instructions given relating to subsequent work with the large-scale maps published by the French Government.

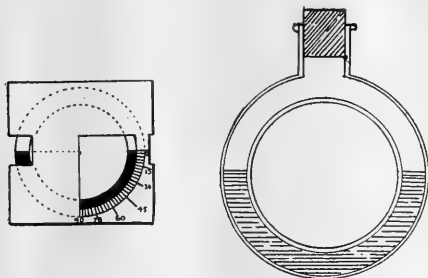

FIG. 6.—Details of the water-level clinometer.

For the angular measurement of elevation, including, therefore, the angular height of the horizon as seen from any monument, the archaeologist is recommended to use a very simple and convenient addition to the compass devised by M. Hue. The method employed can be readily gathered from the accompanying woodcuts, obligingly sent to me by the publishers of the "Manual."

It would be a good thing if some one of our many archaeological societies would prepare an edition of this excellent French manual for the use of British workers.

NORMAN LOCKYER.

PLAGUE AND FLEAS.

IT is a matter of dispute as to where in ancient literature the first definite mention of rats and plague is to be found, and where such mention does occur it is again uncertain what the author intended to convey. It can hardly be doubted, however, that Avicenna, who flourished about the year 1000, clearly refers to this relationship when he says, "Et de eis quae significant illud (the approach of plague) est ut videas mures et animalia quae habitant sub terra fugere ad superficiem terrae et 'pate sedar' id est commoveri hinc inde sicut ebria."

It is noteworthy, however, that Avicenna does not state that the rats died. Passing over many other records of more or less definiteness we come to the important statement of the Byzantine historian Nicephorus Gregoras, who wrote of the plague in Constantinople in 1347, "Nec vero homines solos morbus ille usque flagellabat; sed et si quae alia animalia cum hominibus plerumque degerent et habitarent; canes inquam et equos et cujusque modi avium genera; ipsos etiam mures, si qui forte in domorum parietibus latitabant." Orreaus also, in the plague of Moscow in 1771, mentions rats, but no special stress is laid on the fact, and other animals, as by many other authors, are included. He says, "De avibus a plurimis narrabatur quod minores cantatrices caveis detentae in domibus infectis emorerentur, immo quod mures et glires quantumvis antea copiosi disparuerint; sed de his fides apud relatores esto."

In modern times the death of rats during or before epidemics of human plague was first noticed in India, viz. in Kumaon, 1833-35, by Gowan, in the Pali

plague; 1836-8, by Forbes White; and in Kumaon, 1853, by Francis and Planck. Renny states that during the epidemic of 1851 in Kumaon, in two huts occupied by sixteen men (twelve of whom died of plague) a large number of dead rats was found, but that the cattle, thirty in number, escaped. Rocher, in 1878, in Gun-nam, Baker and Lovry in China, state that the rats were first attacked. Yersin, studying the great epidemic of 1894 in China, states that the rats found dead contained the plague bacillus in abundance, and many of them presented true buboes. Many other observations of a similar kind might be quoted. Not always, however, is the relationship manifest, for Hankin states that despite the most careful inquiries no evidence could be obtained of the existence of an outbreak among rats during or after the outbreak among human beings in Hurdwar. Nor, again, in the epidemic of Glasgow could the relationship be established, though it was proved in the outbreak in 1901-2. Further research will show whether these exceptions are real, or due to insufficient observation.

Not only rats, but other animals have in recent years been found to suffer from plague. Thus there exists in Mongolia a peculiar form of plague known as tarbagan plague. The tarbagan is a marmot-like rodent (*Arctomys bobac*).

Almost every year an epidemic disease breaks out among these marmots, and a marmot that is affected always dies. The natives of the Baikal districts avoid handling any animal that has axillary and inguinal buboes, though dogs and wolves are said to eat them with impunity. In the skinning and handling of these marmots the peasants contract the disease, and epidemics of this origin are reported throughout the whole of the east Asiatic plateau of Siberia and Mongolia to Tibet. The disease is almost undoubtedly plague, though bacteriological proof is not yet forthcoming.

It has been noted, further, that palm squirrels (*Sciurus palmarum*) die of plague in great numbers in certain parts of India. Further, among the Carnivora, dogs and cats may develop plague. In certain parts of India cats have been found in abundance with suppurating buboes in the neck, the position of the bubo, it is interesting to note, suggesting its origin in ingested food (rats). Finally, monkeys have died of plague in several places in India.

Rats and Fleas.—Ogata, in 1897, succeeded in giving a mouse plague by means of bacilli got from fleas taken from rats dead of plague. Simond, in 1898, attributed the infection of man to the fleas which had left the bodies of rats dead from plague.

"It is usually in the morning that the carcass of a rat which has died in the night is fatal to him who touches it. We were unable to discover a single case of a rat whose death had occurred twenty-four hours previously having communicated the plague. Simond also made the following experiment. He placed twenty fleas (obtained from a cat) in a bell jar, with a rat dying of plague. He then placed a healthy rat in a cage into the bell jar, but also allowed the cadaver of the first rat to remain thirty-six hours in the vessel. The second rat died on the fifth day of plague. The experiment was repeated, but not always with success" (Quoted from Nuttall, "Insects, Arachnids, and Myriapods as Carriers of Bacterial and Parasitic Diseases," pp. 9-20).

Simond believed that infection from man to man takes place, but in an insignificant number of cases as compared to those where fleas carry the infection from rat to man. He regards rats as the main cause in the spread of plague among human subjects.

Loir affirmed that the fleas of rats are the main

agents through which the disease is transmitted to man. Koller and Nuttall, however, obtained negative results in this direction. The Indian Plague Commission (1890) came to the conclusion that Simond's proposition that suctorial insects play an important part in the transmission of plague from sick to healthy animals is so weak as to be hardly deserving of consideration.

In 1902 Gauthier and Raybaud, at Marseilles, carried out further experiments, and got positive results.

"Recueillement en bloc un certain nombre de puces sur des rats capturés sains, nous avons parasité artificiellement à leur asile des animaux de laboratoire préalablement inoculés de cultures pures. Nous avons cherché ensuite à produire infestation parasitaire et l'infection consécutive d'animaux neufs. Les résultats absolument concordants de cette série d'expériences (five experiments) nous permettent de conclure que les puces des rats sont capables d'une façon constante de transmettre la peste d'animal à animal rat ou souris."

Further, they showed that rat fleas could bite man.

Ashburton Thompson, studying the plague epidemics in Sydney from the epidemiological standpoint, came to the conclusion that Simond's hypothesis of the flea best explains the phenomena of the epidemic plague as seen at Sydney. He further states that the laboratory proof has been given by Raybaud and Gauthier, and by Dr. J. S. C. Elkington at Bombay, "whose observations are affirmatory of Simond's original experiments made in India."

Elkington¹ describes his own results in the following words:—"The technical difficulties were considerable . . . and a great deal of experiment was required before a satisfactory means was obtained of insuring the captivity of such a small and active insect whilst feeding. This was finally effected by confining them in a test tube of which the mouth was covered with very fine gauze through which the insect could thrust its proboscis when the gauze was applied to the skin of the feeder-animal. Fleas were then fed on experimentally infected rats. . . . The fleas were then kept in a dark drawer still in the feeding tube for varying periods, after which they were again fed on healthy young rats selected for their vigour and health. The results were most successful, and I have records of four instances in which I was able to carry out this method of infection. Captain Liston also was successful in several cases. Attempts were then made to convey the disease from human beings to rats. Two instances were successful, the period from the first feeding being eight hours. . . . Both rats died of plague, one on the fourth, the other on the sixth day."

Much attention was now given to the question as to what species of fleas those found on rats belong.

Tidswell, in 1903, working at Sydney, found that 81 per cent. of the fleas on rats were *P. pallidus* (i.e. *P. cheopis*). Tiraboschi found that 40 per cent. of fleas on ship rats belonged to the same species. Liston, 1905, found that while other species were found on European rats in India, 99 per cent. of the fleas were *P. cheopis*. Though unable himself to get positive results in the transmission, yet he says, "To sum up, then, rat fleas (*P. cheopis*) can always be found in (plague) infected houses; these fleas will take to an animal which is not their normal host." Finally we have the experiments of the Plague Commission of 1905 working in Bombay. These elaborate and very carefully conducted experiments have

conclusively established the fact of the conveyance of plague from the infected to the healthy rat by means of the plague flea. We still require light on the exact method by which the bacilli are conveyed; why so many other investigators have failed in similar experiments, and whether rats transmit the disease in any other way, and, indeed, whether this is the most important way. In discoveries of this kind we are apt to give the credit at the time to the person who forges the last link of the chain which stretches across the gap of unknown causes. Credit is, however, also due to those who forge the intermediate links; indeed, perhaps most of all to him who forged the first link, without which the chain would not have been begun.

J. W. W. S.

Literature.

Consult especially:—

Abel: *Zeit. f. Hygiene*, Heft. xxxvi., 1901.

Tiraboschi: *Zeit. f. Hygiene*, Heft. xlviii., 1904.

Journal of Hygiene, vol. vi., No. 4, September, 1906.

Loir: "Histoire des Epidémies de Peste à Tunis." *Rev. Scientif.*, 1900, No. 13, p. 395.

Allbutt and Rolleston: "System of Medicine," vol. ii., part ii., p. 375, Art. "Plague."

Gauthier et Raybaud: *Revue d'Hygiène*, 1903.

Ashburton Thompson: Report on the Outbreak of Plague at Sydney, dated July, 1903.

J. S. C. Elkington: *Australasian Medical Gazette*, xxii., p. 348.

THE INTERNATIONAL ASSOCIATION OF SEISMOLOGY.

THE first general meeting of the International Association of Seismology was held at The Hague on September 24 and 25, and was preceded on September 21 and 23 by a meeting of the permanent committee, which is the body charged with carrying out the decisions of the general assembly.

The following countries (in alphabetical order according to their French names) now form part of the association:—Germany, Austria, Belgium, Bulgaria, Canada, Chili, Congo, Spain, United States, Great Britain, Greece, Hungary, Japan, Italy, Mexico, Norway, the Colonies of the Netherlands, Portugal, Roumania, Russia, Serbia, and Switzerland. It was understood that the French Government was prepared to join, but as the necessary money grant had not been submitted to the Chamber of Deputies, the adhesion has not yet been formally made. Nevertheless, the French delegates were requested to take part in the proceedings on the same footing as those of the other countries.

The budget for the forthcoming year was submitted to the permanent committee, and was carefully discussed. The income of the association is now about 1900. The secretary, Prof. Kövesligethy, of Budapest, on whom a great part of the labour of the association falls, receives 200.; 460l. is spent in other salaries, including those of a type-writer, mechanic, and in connection with the Central Bureau at Strassburg; office expenses amount to about 150l.

In addition to the above salaries, two scientific assistants, Mr. Rosenthal, of Pulkowa, and Mr. Oddone, of Rome, were during last year paid out of the funds of the association, and were engaged in preparing separate catalogues of microseismic and macroseismic disturbances. The question how far scientific assistants of this kind should during the next two years be maintained by the association was left to the decision of the executive committee, which

¹ Board of Public Health. Address on Fleas and Plague Conveyance by Dr. J. S. C. Elkington, delivered before the Victorian Branch of the British Medical Association, July 22, 1905.

consists of the president, vice-president, and secretary. There is no question, however, that the formation of the catalogues will always form one of the great objects of the association, and its publication will absorb a material fraction of its funds.

One of the subjects discussed at the meetings was the study and origin of small periodic disturbances, some of which have short periods of 6 to 11 seconds, or the somewhat longer period of 30 seconds. The latter seem to occur when strong winds sweep over a country, but no connection of the former with meteorological occurrences has been proved, and the only suggestion of a rational explanation is that due to Prof. Wiechert, who believes them to be due to the impact of ocean waves on the shores. A small committee was appointed to investigate the question, and a sum of 50*l.* was placed at its disposal. Prof. Omori, who had independently expressed the wish to investigate this matter, was also granted a sum of 50*l.* to carry out his investigations.

Another committee was appointed to report on the question of preparing a complete annual index of the literature of the subject. The committee was instructed to enter into communication with the International Catalogue and the "Office international de Bibliographie," in order to ascertain whether one of the existing organisations may be utilised for the purpose.

According to a resolution arrived at in Rome in October, 1906, the president of the association vacates his office on April 1 following the general meetings, which, as a rule, take place every four years. The permanent committee had therefore to elect a new president; Prof. Palazzo, who has held the office during the last year, not being re-eligible, a ballot was taken, and Prof. Arthur Schuster received the majority of votes. In thanking the meeting for the honour bestowed upon him, and accepting the office, Prof. Schuster said that he was not an expert on seismological questions, but considered it to be his duty to accept the position, as he considered that it was intended as a recognition of the services rendered by Great Britain, and notably by Prof. Milne, not only in originating the scientific study of earthquakes, but also in first organising combined observations on an international basis. Prof. Forel, of Lausanne, who is well known through his work on seiches, was elected vice-president.

The general meeting was opened on the morning of September 24 by a speech of the Minister of the Colonies, and the two succeeding days were taken up in great part by addresses on various subjects connected with seismology. Of special interest were the account given by Prince Galitzin of his seismometric studies, and a paper by Prof. Wiechert on the utilisation of seismic records towards the investigation of the physical properties of the earth.

It was the duty of the general meeting to fix the locality of the central bureau, and it was resolved to retain Strassburg for the next period of four years.

The delegates were most hospitably entertained; an evening entertainment, as well as a dinner, was given by the Minister of the Colonies on behalf of the Government of Her Majesty the Queen, and the meeting concluded with an excursion by boat through some of the characteristic canals and inland lakes of the country. Prof. van der Stok, the vice-president, and his able assistants, Dr. Hartmann, Dr. Romeijn, Mr. Levoir, and Baron van Voorst tot Voorst, must be congratulated on the perfection of the organisation, which more than anything else allowed the meeting to do its work smoothly and effectively. The permanent committee will come together in 1909

at some place in Switzerland not yet determined, and the place for the next general meeting in 1911 will then have to be fixed. It was too soon to come to any definite decision, but an informal expression that the meeting might appropriately take place in England seemed to meet with a very general approval.

SIR F. L. McCLINTOCK, K.C.B., F.R.S.

ADMIRAL SIR FRANCIS LEOPOLD McCLINTOCK, whose death on Sunday last, at eighty-eight years of age, we regret to announce, will be remembered so long as the story of polar exploration has any interest for the human race. Fifty years have passed since the *Fox*, with Sir Leopold (then Captain) McClintock in command, sailed in search of the Franklin expedition, and the fiftieth anniversary of this memorable event was appropriately marked on June 30 last by a letter of congratulation sent to him from the Royal Geographical Society.

Sir Leopold McClintock's Arctic service began in 1848, when he accompanied Sir James Clark Ross as second lieutenant on board H.M.S. *Enterprise*, in the expedition sent out by the Admiralty. Returning unsuccessful in November, 1849, McClintock joined a second expedition sent out early in 1850 as senior lieutenant of H.M.S. *Assistance*, with Sir Erasmus Ommanney. It was his fortune in August, 1850, to see, at Cape Riley, the first traces of the missing Franklin expedition. In the following spring, whilst frozen up at Griffith Island, he signalled himself by a remarkable sledge journey of 80 days and 760 geographical miles, reaching the most westerly point which had been attained from the east in the Arctic regions. Upon the return of this expedition to England in October, 1851, he was promoted to the rank of commander; and in the following spring he proceeded to the Arctic regions in command of H.M.S. *Intrepid*, one of five vessels composing the third searching expedition, under Sir Edward Belcher's command. In accordance with instructions from the Admiralty, the *Intrepid*, in company with the *Resolute*, Captain Kellett, wintered at Melville Island, in order to search for Captain McClure and his companions; and, fortunately, they were discovered and rescued, after their three years' imprisonment in the ice. McClintock again distinguished himself by his sledge journey of 105 days and 1210 geographical miles into the hitherto unexplored region northward of Melville Island. The advances which Arctic sledge-travelling has made are almost entirely due to the improvements effected by him. Abandoning four out of the five ships imbedded in the ice, and also McClure's ship, the *Investigator*, the *personnel* of this expedition, with McClure and his companions, returned to England in October, 1854, in the depot ship *North Star*, and two relief ships, freshly arrived out, under Captain Inglefield.

In 1857 McClintock accepted the command of the search expedition fitted out mostly at Lady Franklin's expense. He selected and equipped the steam-yacht *Fox*, of 177 tons, and with twenty-four companions sailed on July 1, 1857. He returned on September 20, 1859, having discovered, upon the north-west shore of King William's Island, a record announcing the death of Sir John Franklin and the abandonment of the *Erebus* and *Terror*. He brought home intelligence of their discoveries and the fate of their crews, and many relics of the expedition. The story of this voyage was fully related by McClintock himself in "The Voyage of the *Fox* in the Arctic Seas: a Narrative of the Discovery of the Fate of Sir John Franklin and his Companions," a work which ran through

many editions, and is a classic story of geographical achievement. In recognition of his services McClintock was knighted, and in 1865 was elected a Fellow of the Royal Society. He was appointed a K.C.B. in 1867.

NOTES.

In consequence of numerous reports as to the occurrence of a very serious disease among bees in the Isle of Wight, known locally as "paralysis," the Board of Agriculture and Fisheries instructed Mr. A. D. Imms to undertake an inquiry into the nature and cause of the disease; his report on the result of his investigations has now been issued by the Board in pamphlet form. Fortunately, the geographical distribution of the disease is confined apparently to the Isle of Wight, so that with due precaution there should be little or no fear of its spreading to the mainland apiaries. "The disease is eminently one of the digestive system, and might be described as being a condition of enlargement of the hind intestine." Smears made from the contents of the colon showed large numbers of bacteria, and it is possible that there may be some connection between this disease and the well-known form of "dysentery" in bees. The symptoms are complete loss of flight, crawling aimlessly over the ground or up grass stems and the supports of the hive.

THE cablegrams from America in Monday's papers announced the tragic death of Prof. L. M. Underwood, of Columbia University, New York. His mind had been unshaken by the recent financial crisis, and he committed suicide after killing his wife and attempting to kill his daughter. He was born in New York State in 1853, and became professor of botany in Columbia University in 1896. His published works included "Descriptive Catalogue of North American Hepatice," "Moulds, Mildews and Mushrooms," "Our Native Ferns and their Allies," and "Our Native Ferns and How to Study Them."

At the unanimous invitation of the executive committee of the Yorkshire Naturalists' Union, Dr. Wheelton Hind has accepted the presidency of the union for the forthcoming year. Dr. Hind is well known throughout the country for his successful work amongst Carboniferous rocks, and in Yorkshire he has been unusually successful in identifying and tracing various zones in the Carboniferous limestone. His work in Yorkshire makes the selection of him as president of the county society very appropriate, and will doubtless result in increased attention being paid to the geological problems of the Carboniferous period by the members of the union.

THE gold medal of the Institution of Mining and Metallurgy has been awarded to Sir Archibald Geikie, K.C.B., F.R.S., in recognition of his services to geological science. The Consolidated Gold Fields of South Africa gold medal and premium has been awarded to Dr. T. K. Rose for his researches on the metallurgy of gold.

THE programme of the arrangements for the new session of the Society of Arts which has just been issued includes a series of six lectures on industrial hygiene by different experts, who will deal with such subjects as dust in factories and in mines, lead and mercury poisoning in pottery and match-making, work in compressed air, and child labour. A course of lectures on the "Navigation of the Air" is to be given under the Shaw trust by Dr. Hele Shaw, F.R.S. Four courses of Cantor lectures are announced, the first on the microscope, by Mr. Conrad

Beck. There is a very full list of papers for the ordinary and sectional meetings, and at Christmas Mr. Martin Duncan will lecture to a juvenile audience on the cinematograph.

DR. KOCI, who returned to Berlin early this month after an absence of eighteen months in German East Africa, has been promoted to the rank of Wirklicher Geheimer Rath, with the title of Excellency, in recognition of his researches into the causes of the sleeping sickness.

At the meeting of the London Mathematical Society on November 14, the council and officers for the ensuing session were elected as follows:—*President*, Prof. W. Burnside; *vice-presidents*, Prof. A. R. Forsyth and Prof. H. M. Macdonald; *treasurer*, Prof. J. Larmor; *secretaries*, Prof. A. E. H. Love and Mr. J. H. Grace; *other members of the council*, Dr. H. F. Baker, Mr. A. Berry, Mr. T. J. I'A. Bromwich, Mr. A. L. Dixon, Prof. E. B. Elliott, Mr. G. H. Hardy, Dr. E. W. Hobson, Sir W. D. Niven, Mr. H. W. Richmond, and Mr. A. E. Western.

THE *Times* correspondent at Paris gives in the issue of November 14 particulars of an improvement of wireless telegraphy apparatus on board French warships which has enabled communication to be made with facility at a distance of 750 kilometres (466 miles), while the previous maximum distance was 300 kilometres (186 miles). According to a telegram from Algiers, the cruiser *République*, on leaving Toulon, proceeded to Ajaccio, a port chosen in order to increase the difficulties of transmission to the *Jules Ferry*, anchored at Toulon, Ajaccio being situated in a hollow of the mountains. Communication was maintained without interruption between the two ships while the *République* was *en route*. It is also stated that the *République* has been able to communicate with the Eiffel Tower in Paris from the Golfe de Jouan, in the Alpes Maritimes Department, a distance of 800 kilometres (500 miles), the ship not merely receiving messages from the tower, but communicating with it in reply.

A PROMISING career has been cut short by the death, on November 12, of Dr. A. M. Pirrie, at the early age of twenty-eight. Dr. Pirrie went to the Sudan in 1906 as anthropologist to the Wellcome Research Laboratories at the Gordon Memorial College, Khartoum. Under the direction of Dr. Balfour, the director of the laboratories, he made his first expedition up the Nile to the southern limits of the Sudan, and penetrated to remote parts of the Bahr-el-Ghazal. A second expedition took him to the borders of Abyssinia. On both occasions he was engaged on anthropological and physiological researches into tropical diseases; but unfortunately he contracted fever, and was compelled to return to England. Dr. Pirrie brought back a valuable collection of objects of anthropological and other scientific interest, and at intervals during his illness he was engaged on his report to the Carnegie Institution and the Wellcome Research Laboratories, Khartoum, for which institutions he acted jointly in the work he carried out in the Sudan.

THE sixth annual meeting of the South African Association for the Advancement of Science will be held at Grahamstown during the week ending July 11, 1908, under the presidency of the Hon. Sir Walter Hely-Hutchinson, G.C.M.G. The presidents of the sections are as follows:—Section A, mathematics, physics, astronomy, meteorology, geodesy, and geography, Prof. Alexander Ogg, of Rhodes University College, Grahamstown; Sections B and C chemistry, metallurgy, mineralogy and geology, engineer-

ing, mining and architecture, Prof. E. H. L. Schwarz, of Rhodes University College, Grahamstown; Section D, botany, zoology, agriculture and forestry, bacteriology, physiology, hygiene, Dr. S. Schönland; Section E, education, philology, psychology, history and archaeology, Mr. W. G. Bennie; Section F, economics and statistics, sociology, anthropology and ethnology, Mr. W. Hammond Tooke. The local honorary secretary at Grahamstown is Prof. J. E. Duerden, of the Rhodes University College.

THE Paris correspondent of the *Times* states that, according to a telegram from Montpellier, a mass of earth, having a volume of about 400,000 cubic metres, and forming one whole slope, as it were, of Mont Bringuet, near Lodève, in the Department of the Hérault, has become detached and has moved over a distance of about 1200 feet, carrying with it the tilled soil, fields, woods, and meadows, and obliterating all the ordinary landmarks, bridges, roads, &c., on its passage. A large chestnut grove has thus been moved about 500 feet without, apparently, suffering any damage, but numerous lakes have been formed in the vicinity, and the spectacle is said to resemble that of a region devastated by an earthquake.

AN appeal to the charitable public on behalf of the underfed children attending elementary schools has reached us from the London County Council. For many years past various associations have rendered valuable assistance in collecting and distributing funds. With these associations the Council is in close connection, and every effort is being made to bring the Council, the associations, and the schools into such relationship as will result in a highly efficient organisation for relieving distress. In order to meet the needs of the coming winter, the Council is anxious that at least 15,000*l.* should be raised. If, however, the response is not adequate this winter, there will probably be no alternative in the winter of 1908-9 but to resort to the rates. The Council has voted a sum for equipment and appliances, and will place every convenience at the disposal of the associations. Contributions may be sent to any of the other associations cooperating with the Council, or to Mr. H. Percy Harris, chairman of the London County Council, 98 Gloucester Terrace, Hyde Park, W.; Mr. John T. Taylor, chairman of the Education Committee, 19 Woodchurch Road, Hampstead, N.W.; or Mr. E. A. H. Joy, chairman of the Subcommittee on Underfed Children, Tower House, Woolwich.

A MEETING of representatives of sanitary committees of county and borough councils and port sanitary authorities of England and Wales was held at Caxton Hall, Westminster, on November 13. The object in view was to consider the establishment of a permanent union of such authorities to secure uniformity of action in the administration of matters relating to public health. Mr. H. W. Newton, chairman of the sanitary committee of the Newcastle Corporation, who presided, moved the following resolution, which, after considerable discussion, was adopted by a large majority. The resolution approved of the establishment of a union of the sanitary authorities of England and Wales for the purpose of promoting the public-health interests of the nation. The union is to have for its immediate objects:—(1) to secure, so far as may be practicable, harmony of interest and uniformity of action among sanitary authorities in general on matters relating to the public health; (2) to stimulate and concentrate effort for the purpose of effecting necessary sanitary reforms, whether for the public weal or the benefit of individual sanitary districts; (3) to encourage and promote the study of practical hygiene, and to educate

opinion with respect to the national as well as the local importance of public-health work in general; (4) to consider the different conditions and circumstances, general or local, whereby disease is liable to be caused to man, and, so far as may be, to obtain their removal. Other resolutions were also adopted empowering the chairman and Dr. H. E. Armstrong, of Newcastle, as a provisional committee, to draw up a constitution to be discussed afterwards, and to communicate with sanitary authorities asking their adhesion to the union under the name of "National Union of Public Health Authorities."

THE October issue of the *Museums Journal* is illustrated with a portrait of the late Mr. John MacLauchlan, president of the Museums Association, 1906-7. Mr. MacLauchlan presided at the July meeting of the association in Dundee, when he appeared to be in excellent health, but in September he was prostrated by the acute development of a mortal disease with which he had been afflicted for some time, and on October 1 the attack had a fatal termination.

IN the August number of the *Philippine Journal of Science* (ii., No. 4), Lieut. Clarence Cole records the frequent occurrence of the parasitic worm *Necator americanus* in natives of the Philippine Islands; Mr. Harry Marshall gives a good summary of the trend of recent research in immunity; and Dr. Musgrave and Mr. Richmond discuss the relation of infant feeding and infant mortality in the Philippines.

WE have received No. 8 of vol. i. of the Bulletin of the Committee for the Study of Special Diseases, Cambridge. It contains an inquiry into the value of the opsonic index by Messrs. FitzGerald, Whiteman, and Strangeways. As the result of an enormous amount of work, the conclusion is arrived at that, unless at least 1000 cells are counted, the percentage error may be so great as to render the method worthless. In view of the concordant experience of a number of different observers on the value of the method, this conclusion cannot be accepted as final, though it is difficult to detect any fallacy in the experimental details.

TO the sixth number of *British Birds* Mr. H. S. Gladstone communicates some interesting particulars with regard to the Irish nesting-colony of red-necked phalaropes, the one place in the United Kingdom where the species is known to breed. Although not reported until 1903, it appears that a few pairs of the birds had established themselves three years previously. In 1902 seventeen birds, mostly females, were seen; two years later Mr. Gladstone estimated the number at thirty pairs, while in 1905, when the nesting-area had become considerably enlarged, he considered there were nearly fifty couples. Unfortunately, the original tenant, who did all he could to protect the birds, has left the farm, and there are ugly reports of a big egg-raid having taken place during the past season.

A REMARKABLE new dipterid larva, *Acanthomera tetra-truncum*, from Paraguay, is described by Mr. Karl Fiebrig in the *Zeitschrift für wissenschaftliche Insectenbiologie*, ser. 2, vol. ii., pp. 316-323 and 344-347. The larva, it appears, is a wood-borer, and has the mouth-parts modified into a powerful boring organ. The terminal segment of the body forms an extremely hard, chitinous shield, beneath which is a "mouth-like" chamber for the reception of the posterior stigmata, these being thereby completely protected from contact with foreign bodies. There is, moreover, a finger-shaped tracheal organ in this region which may act as a kind of "gill-stigma." The adapta-

tion of the larva to its peculiar mode of existence is thus very marked. The larval stage seems to be unusually prolonged, an apparently almost full-grown larva observed at the end of July not having developed into the imago until the following January. As it was observed to be still active a short time before the final transformation the pupa-stage is inferred to be brief. An enlarged figure of the adult fly is given in the second part of the paper.

Two papers in the October number of the *Journal of Anatomy and Physiology* relating to Australian natives are of more than ordinary interest. In the first, Dr. W. L. H. Duckworth describes several brains, pointing out that these afford evidence of the low grade of the aborigines. They frequently show, for example, features very rarely met with in the white races, which are, however, normal in apes. Such simian features are, nevertheless, by no means restricted to Australians, whose brains are in other respects essentially human. In the second paper Dr. Ramsay Smith, after describing the results of an investigation into the mode of development of the teeth of Australians, discusses the bearing of this on tooth-development generally. He finds that simple cuspidate teeth, like canines and incisors, are developed from a single tube of dentine, tipped or capped with enamel, and also that this development takes place by constriction. This being so, he urges that in the case of complex teeth, such as molars, in place of any fusion or absorption of cusps, development has taken place by plication or constriction of an original primitive, single, simple tube, according to the method revealed by his observations. Hence the theory of the origin of "heterodont" teeth from fused primitive cones, as well as the theory of the aggregation of cusps, so far at least as it involves the origin of roots, must be re-considered.

ON the subject of school gardens, attention is directed in the editorial of *Irish Gardening* to the absence of these in Ireland, although it is an essentially agricultural country, while in most European countries they have been extensively provided. Mr. W. Johnston contributes a practical article on raspberry cultivation, and Mr. P. Brock writes on the propagation of chrysanthemums; special articles are also concerned with the development and classes of carnations, and the culture of Cape heaths.

MISS A. G. STOKEY has contributed to the July number of the *Botanical Gazette* a description of the roots of *Lycopodium pithyoides*, a subterranean plant in which every stem is a potential sporophyll. The stem is characterised by the large number of roots that run through the cortex, amounting to more than fifty in one instance. The roots arise within a few millimetres of the apex of apparently mature stems. The vascular strand in the root shows in transverse section a crescent-shaped mass of xylem, with phloem lying between the horns of the crescent. At the apex of the root four distinct initial regions can be distinguished.

WITH the object of disseminating the information locally and for others interested, Dr. W. L. Bray has prepared an account, published as Bulletin No. 82 of the University of Texas, of the distribution and adaptation of the vegetation in that State. The factors that control the various plant zones are discussed upon the principles laid down in Schimper's "Pflanzen-Geographie." In connection with water supply, the author distinguishes primarily a moisture-demanding vegetation in east Texas and a dry-climate vegetation in west Texas. Mesophytic types of woodland, notably long- and short-leaf pine and mixed

forests, are characteristic of the east, whereas in the west, xerophytic formations abound, such as the "chaparral" scrub, grassy plains, and the "sotol" country inhabited by succulents and dwarf shrubs. There is also a wide range of temperature, from the semi-tropical region where the culture of tropical plants is only prevented by occasional forests, to a cold zone where the Douglas spruce is dominant. Between these lie the "cotton-belt" and the "corn-belt."

IN the September number of the Cape of Good Hope *Agricultural Journal*, Mr. Robertson describes his investigations on a local cattle disease he considers to be identical with Nocard and Leclinc's "pasteurellose." He isolated from the affected tissues a bacillus which produces all the symptoms of the disease when inoculated into healthy sheep or cattle. Dr. Nobbs also gives an account of the work proposed to be done at the experiment stations at Knysna, on the wet "sour veld," and at Robertson, in the semi-arid "Karoo" district. These two widely different types of country are fairly common in Cape Colony. "Sour veld" is known by its vegetation; much of it is, or was, forest, but a good deal is covered with scrubby bushes 2 feet to 10 feet high, and reeds, sedges, bracken, and the sugar-bush family (Proteaceae) are numerous. There is abundant rainfall. The land is being brought into cultivation, but is found to be very sterile in spite of being virgin soil of excellent mechanical condition. Cropping, manuring, and tillage experiments are in progress. On the fertile "Karoo" land the conditions are altogether different; the rainfall is only 10 inches or 12 inches, and as this comes chiefly in winter, recourse must be had to irrigation and special cultivation methods during summer. The experiments at Robertson are in these directions.

THE Bulletin of the American Geographical Society, Nos. 7, 8, contains a paper by Miss E. C. Semple on geographical boundaries. After dwelling on the indefinite character of most natural boundaries, Miss Semple gives an account of the conditions generally existing in the border zone between two races or states, illustrations being afforded by the early history of the United States and the wide frontier between Russia and the East. The system of maintaining a waste boundary strip for protective purposes has been superseded in modern States by a fixed political boundary, which, however, does not prevent the existence of a frontier district, the inhabitants of which are generally a mixed race of the two contiguous elements. By means of a map showing the races of Central Europe, the migrations of Slav and Teuton over the political boundary are strikingly illustrated. Attention is also directed to the tendency of border zones to become inhabited by undesirable refugees from both sides.

IN compliance with a request made by the Solar Commission of the Meteorological Congress at Innsbruck in 1905, the Weather Bureau of the Philippines has published a useful statement of the rainfall of that archipelago, in the preparation of which all the available data at the disposal of the Manila Observatory have been revised by the Rev. M. S. Masó, S.J., under the direction of the Rev. Father Algué. The rainfall differs considerably, owing to the extension of the archipelago in the N.-S. direction; the annual average amount is about 87 inches, the extreme values being 35.5 inches and about 157 inches. Three different climates are distinguished; the first and worst has two well-defined seasons, wet and dry, in which more than 80 per cent. of the annual fall

occurs during the summer months. The second climate consists of eight or nine rainy months, the percentage being high in both summer and winter. The third and best climate has a fairly even distribution of rainfall over the whole year. Reference should be made to the paper in question for particulars as to the location of these districts; tables are given showing the monthly and annual rainfall at all stations.

THE Journal of the Franklin Institute (vol. clxiv., No. 4) contains an interesting report on the development of the American locomotive as exemplified in the Baldwin Locomotive Works of Philadelphia. Founded in 1831, the works in 1832 completed one locomotive and employed thirty men. In 1906 they built 2652 locomotives and employed 17,432 men. Illustrations are given of seventeen locomotives of different types made by the company, the most interesting being the famous "Old Ironsides," completed and tried on November 23, 1832. In these early days mechanics were few, and suitable tools could hardly be obtained. Cylinders had to be bored with a chisel, fastened in a block of wood, whilst blacksmiths who could weld bars of iron exceeding $1\frac{1}{4}$ -inch square were not to be

more rapidly than the copper, it may safely be assumed that the mean composition of the alloy was 75 per cent. of copper and 25 per cent. of tin. The strikingly large proportion of tin in the alloy is quite unusual for bronzes of that period, which usually contain 90 per cent. of copper and 10 per cent. of tin, and the oldest bronzes of all are still poorer in tin. The die affords remarkable evidence of the metallurgical skill of the ancients. The extreme hardness required for a die was secured by increasing the proportion of tin, whilst the requisite malleability was secured by carefully using in the preparation of the alloy the purest copper and tin, absolutely free from lead or zinc, which would have made it softer, and from antimony and arsenic, which would have made it brittle.

MADAME CURIE announces in the October number of *Le Radium* the result of her re-determination of the atomic weight of radium under conditions much more favourable to accuracy than those which existed in 1902, when she had only 9 centigrams of chloride of radium on which to work. The present determination has been made with 4 decigrams by the method used in the former case, and gives as the result 226.2, if the atomic weight of silver be taken as 107.8. Madame Curie estimates the possible error of the determination as less than half a unit.

THE Munich *Medizinische Wochenschrift* for October 15 contains a description of an induction coil for Röntgen-ray work, constructed by Dr. J. Rosenthal, which is capable of producing a photograph of a man's thorax in two seconds with the tube 50 centimetres away. This certainly brings us nearer to the much desired Röntgen-ray kinematograph of the action of important organs like the heart, and it is to be hoped that Dr. Rosenthal will succeed in still further reducing the time of exposure. One feature of his coil is the division of both primary and secondary into two or more parts, which can be

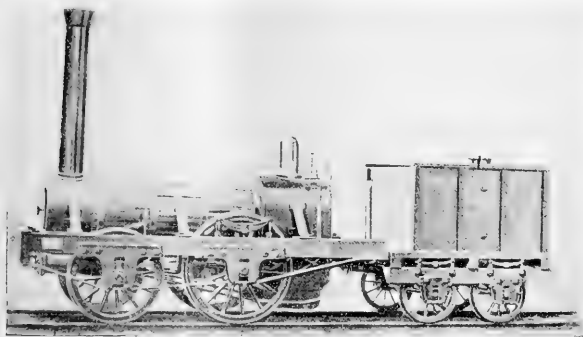

"Old Ironsides" Locomotive.

had. Mathias Baldwin, therefore, had to do most of the work himself in order to educate the men who assisted him to fashion the necessary tools for the various processes.

In view of the large number of ancient coins and medals that have been preserved, it is surprising that so little is known regarding the dies used. Some important contributions to the knowledge of the subject are made by Prof. C. Zenghelis in the *Chemiker Zeitung* of November 9. In 1904 a die used for coinage was found by a native at Tel El Athrib, Egypt, and was subsequently presented to the museum at Athens. It dates from 430 B.C. to 322 B.C., and is probably the only genuine antique die preserved. It consists of bronze, and is 6 cm. high and weighs 164.12 grams. On the base is engraved the owl exhibited by the Athenian tetradrachma pieces. The surface was covered partly with a patina of copper carbonate and partly with red cuprous oxide. On analysis it was found that the die consisted of a bronze with 22.51 per cent. of tin and 69.85 per cent. of copper. The remaining 7.64 per cent. undoubtedly consisted of oxygen, as careful tests failed to show the presence of other elements. Some cuprous oxide was mixed with the material for analysis, and as in such alloys the tin oxidises

placed in series or in parallel with each other without stopping the coil.

THE August Bulletin of the Bureau of Standards of Washington contains an article on the melting points of the elements of the iron group by Mr. G. H. Burgess. The determinations were made by placing minute quantities (0.001 milligram) of the elements on a platinum strip heated by the passage of an electric current through it. The temperature of the strip was measured by an optical pyrometer standardised by reference to the melting points of zinc, 419° C.; antimony, 630.5° C.; copper, 1084° C.; and platinum, 1753° C. The results are as follows:—iron, 1505° C.; chromium, 1489° C.; cobalt, 1404° C.; nickel, 1435° C.; manganese, 1207° C.

THE report of the director and librarian to the Warrington Museum Committee for the year ending June 30 provides evidence that good work in the direction of encouraging scientific observation is being done at Warrington with the aid of the museum and its staff. Among other arrangements made at the museum to interest students and young pupils in natural history may be mentioned the wild-flower table, which appears to be visited regularly by students and by teachers preparing

object-lessons. With the assistance of voluntary helpers, the staff provided for the table during the year more than 2500 specimens of freshly gathered wild-flowers, the greatest number on a single day being 168, on July 23.

The Proceedings of the council of the Institute of Chemistry from July to October of the present year show that the council has directed the attention of the Local Government Board to the desirability of making the condition of appointment of public analysts attractive to candidates with the highest qualifications, and has also urged that the tenure of offices held by men of such ability and experience should be made more secure. Approval is expressed of the action of the County Council of East Suffolk, which has lately set an example by empowering the county coroner to order an analysis by a properly qualified analyst in any case of suspected poison, not being one of alleged foul play. The council has deemed it desirable to advise fellows or associates of the institute who may be seeking appointments in India to make sure they are gazetted as officers, and recognised as such in the regulations of the department under which they are seeking appointment, so that they may not find themselves in a position inferior to that to which they have a right, both officially and socially.

The annual report of the Smithsonian Institution for the year ending June 30, 1906, has been received. Of its 546 pages, ninety-one refer to administrative matters, and include the reports of the executive committee of the Board of Regents and the acting secretary, Mr. Richard Rathbun, together with the Acts and Resolutions of Congress relative to the Smithsonian Institution adopted during the year. The appendix is again the most extensive and interesting part of the publication. Among other important contributions to this part of the volume we notice the translations of Madame Curie's opening lecture at the Sorbonne on November 5, 1906, on modern theories of electricity and matter; Prof. Himstedt's essay on radio-activity; M. H. Radau's account of astronomy on Mont Blanc; an abstract of M. A. Lacroix's description of Vesuvius in eruption in April, 1906; M. E. Bugnion's contribution to polyembryony and the determination of sex; Herr E. Pfizenmayer's contribution to the morphology of the mammoth; M. L. Cuñot's lecture on heredity; M. A. Yermoleff's description of the bisons of the Caucasus; Dr. Jakob Huber's account of the founding of colonies by Atta Sexdens; M. Hugues Obermaier's description of Quaternary human remains in central Europe; Prof. R. Blanchard's lecture on zoology and medicine; and M. Eugène Lemaire's account of the rôle of chemistry in paintings. Among original contributions to the appendix are those of Mr. C. G. Abbot on recent progress in astronomical research, and Mr. C. J. Blanchard on the national reclamation of arid lands. Royal Institution discourses reprinted include those of Mr. Marconi on recent advances in wireless telegraphy, and Prof. Schuster on international science. As usual, the appendix contains a profusion of beautiful illustrations.

A third impression of Dr. David Nabarro's "Laws of Health" has been published by Mr. Edward Arnold. The book provides a simply worded description of the organs of the human body, and much sensible advice as to how to ensure their health and general well-being. The author has acquainted himself with the needs of schools, and his book should be of service to teachers in the preparation of lessons on elementary hygiene.

The third volume of the "Index of Economic Material in Documents of the States of the United States" has

been received. The index is being prepared for the department of economics and sociology of the Carnegie Institution of Washington, and is being published by the institution. The present instalment is by Adelaide R. Hasse, and is concerned wholly with the documents of Vermont, and deals with the years 1789-1904. The index is confined to printed reports of administrative officers, legislative committees, and special commissions of the States, and to governors' messages. It does not refer particularly to constitutions, laws and legislative proceedings, or to court decisions.

OUR ASTRONOMICAL COLUMN.

A LARGE SOLAR PROMINENCE.—Dr. A. A. Rambaut, F.R.S., sends us particulars of a large solar prominence observed by him on Friday last, November 15, at the Radcliffe Observatory, Oxford. Using a slit tangential to the sun's limb, a prominence having the form of two smooth rounded hills was observed at 1h. 45m., and it quickly increased in height until it filled the slit. A few minutes later the whole aperture in the brass plate to which the jaws of the slit were attached on the collimator was not large enough to contain the whole of the outburst. The prominence was in position-angle 273° on the sun's disc measured in the usual way from the north point through east. A sun-spot of fair size, surrounded by masses of bright faculae, was visible in nearly the same position-angle and near the limb. In the interval between 1h. 56m. and 12h. 10m., that is, in fourteen minutes, the height of the prominence increased 140,000 miles, so the rate of increase was 10,000 miles per minute, or 167 miles per second. The height attained was 324,000 miles.

MELLISSH'S COMET, 1907e.—A new set of elements, calculated from places observed on October 15 and 19 and November 2, and a daily ephemeris for comet 1907e, are published by Herr M. Ebell in No. 4212 (p. 195, November 7) of the *Astronomische Nachrichten*. The following is an abstract from the ephemeris:—

Ephemeris 12h. (M.T. Berlin).						
1907	α (app.) h. m.	δ (app.) m.	lgr	log Δ	Bright- ness	
Nov. 20	2 14.3	+28 8.4	0.1720	9.7179	1.66	
" 24	1 32.0	+28 33.1	0.1855	9.7865	1.14	
" 28	1 19.0	+28 19.9	0.1987	9.8541	0.78	
Dec. 2	0 40.5	+27 55.1	0.2116	9.9172	0.55	
" 6	0 25.3	+27 29.7	0.2243	9.9748	0.40	

At the time of unit brightness (October 15) the comet's magnitude was about 9.5.

On November 23 the comet will pass about 40' S. of α Trianguli, and on November 28 it will be 63° S. of β Andromede, crossing the meridian at about 8.30 p.m.

MARS AS THE ABODE OF LIFE.—The *Century Magazine* for November (No. 1, vol. lxxv., p. 113) contains the first of a series of articles on the possibility of Mars being inhabitable, in which Prof. Lowell discusses, as an introduction, the possible origin and evolution of planets. He commences with a description of meteorites, and traces out the various steps of the meteoritic hypothesis, and then defines six stages through which the cooling celestial mass passes in its progress from a self-luminous sun to a cold dead body. Discussing the present aspects of the planets, he shows that these are in accord with the stages defined, and points out that the crumpling which produces landscape variations is essentially an effect of cooling. The relative roughness of the surfaces of the earth, of Mars, and of the moon is then discussed, and the comparatively abnormal mountainous character of the last-named explained by its initial temperature being the temperature of the combined earth and moon masses, and therefore sufficient to produce, in the cooling of so small a mass, the huge lunar mountains with which we are familiar; the non-mountainous character of the Martian landscape is also explained. This first paper concludes with a discussion of the formation and distribution of continental and oceanic areas.

SATURN'S RINGS.—Several recent observations of Saturn's rings are reported in No. 4213 (p. 219, November 10) of the *Astronomische Nachrichten*. Dr. Ristenpart reports that on November 5 he was able to see the ring distinctly, as a ghost-like fine line, with the 12-inch equatorial of the Urania Observatory at Berlin.

Prof. Hartwig, observing at Bamberg on November 7, was surprised to find that the ring on both sides appeared of a reddish-brown colour. The shadow of the rings on the surface of the planet was very distinct, and broader than it was four weeks previously. A telegram from Cambridge (Mass.) reports that Prof. Lowell confirms the observation of the symmetrical knots in Saturn's rings made by Prof. Campbell.

In the same journal Herr Paul Guthnick places on record the results of observations of Saturn's rings and satellites made at the Royal Observatory, Berlin, during part of the week referred to by Prof. Campbell.

ELEMENTS AND EPHEMERIS FOR THE MINOR PLANET PATROCLUS.—A set of elements and an ephemeris, covering the period October 31 to November 16, for Patroclus (1066 VY), one of the three Jovian asteroids, are given in No. 4212 (p. 193, November 7) of the *Astronomische Nachrichten* by Herr V. Heinrich. The opposition will take place on November 30, the magnitude of the minor planet being 14.5.

COMPARISONS OF THE PLACES OF MARS FOR THE OPPOSITIONS OF 1907 AND 1909.—In a paper communicated to the Royal Astronomical Society (Monthly Notices, vol. lxviii., No. 9, p. 575) Dr. Downing compares the places of Mars calculated from Newcomb's tables with the places calculated from Le Verrier's tables near the times of opposition in 1907 and 1909. The results are tabulated for every eight days from May 26 to August 14, 1907, and from August 14 to November 2, 1909. On September 23, 1909 (near the time of opposition), the correction to Le Verrier's place is -10.5 seconds of arc in R.A. and $-5.5''$ in declination, to his heliocentric longitude of Mars $-4.1'$, and to the longitude of the sun $-6.9''$; the distance of Mars from the earth will be 0.39.

SCIENCE AT THE FRANCO-BRITISH EXHIBITION OF 1908.

IT has been announced in various newspapers that there will be a Franco-British Exhibition next year. Those who have passed near Uxbridge Road will have also noticed that a large area of ground is being covered rapidly with exhibition buildings.

According to its prospectus, it is to be an exhibition of science, arts, and industries, and it is a matter of concern to all English men of science to see that in such an exhibition science is given its proper place.

Up to the present time no accounts of any attempt to represent science at this exhibition have been made public; we give, therefore, a short sketch of the efforts which are being made to have a pure science section as a part of the exhibition. Such a section is a novelty in exhibitions, and that there will be a science section is due to the action of the British Science Guild. That body approached the executive committee of the exhibition, suggesting that a section should be set apart for pure science, dealing mainly with original research as carried on both in the laboratory and in factories.

The executive committee accepted the suggestion, and a committee was formed which has been at work since June last.

It is hoped that the French side of the exhibition will deal with French science in a similar way.

The committee is constituted as follows:—Sir Norman Lockyer, K.C.B., F.R.S., chairman; Prof. John Perry, F.R.S., vice-chairman; Sir Alexander Pedler, C.I.E., F.R.S., hon. secretary. Members: Captain Sir Wm. de W. Abney, K.C.B., F.R.S., Prof. J. O. Arnold, Major B. F. S. Baden-Powell, Dr. F. A. Bather, Prof. C. V. Boys, F.R.S., Prof. Callendar, F.R.S., Major Close, R.E., Captain Ettrick W. Creak, R.N., C.B., F.R.S., Mr. Horace Darwin, F.R.S., Prof. J. A. Ewing, F.R.S., Prof. Farmer, F.R.S., Rear-Admiral Field, F.R.S., Mr. L. Fletcher,

F.R.S., Mr. G. H. Fowler, Sir Archibald Geikie, K.C.B., F.R.S., Sir David Gill, K.C.B., F.R.S., Dr. R. T. Glazebrook, F.R.S., Prof. Gotch, F.R.S., Mr. Walter Rosenhain, Colonel Hellard, R.E.; Colonel Sir Thomas Holdich, K.C.M.G., K.C.I.E., C.B., Sir E. Ray Lankester, F.R.S., Dr. W. J. Lockyer, Prof. R. Meldola, F.R.S., Prof. H. A. Miers, F.R.S., Dr. H. R. Mill, Prof. Milne, F.R.S., Prof. Poulton, F.R.S., Lieut.-Colonel D. Prain, C.I.E., F.R.S., Sir William H. Preece, K.C.B., F.R.S., Sir William Ramsay, K.C.B., F.R.S., Dr. Ridewood, Mr. Frederick Rudler, I.S.O., Prof. Rutherford, F.R.S., Dr. W. N. Shaw, F.R.S., Mr. A. E. Shipley, F.R.S., Mr. L. J. Spencer, Dr. J. J. H. Teall, F.R.S., Prof. Silvanus Thompson, F.R.S., Prof. T. E. Thorpe, C.B., F.R.S., Prof. Trouton, F.R.S., Colonel Sir Charles M. Watson, R.E., K.C.M.G., C.B., Sir H. Trueman Wood.

The exhibits are for convenience subdivided into three sections:—

- (a) Historical apparatus which has been used by eminent scientific discoverers, or has been the means of elucidating important truths.
- (b) Instruments and methods used in experiments and observations, including those used in laboratory and works research.
- (c) Instruments and methods used in and results obtained from the exploration of (1) the land; (2) the sea; (3) the air; (4) the heavens.

The various subjects are dealt with as follows:—
Division 1: arithmetic and mathematical science, geometry, measurement, molecular physics, and sound. Subcommittee, Prof. Perry, Prof. C. V. Boys, and Mr. Horace Darwin; convener, Prof. Perry.

Division 2: light and photography. Subcommittee, Captain Sir Wm. de W. Abney and Sir H. T. Wood; convener, Sir H. T. Wood.
Division 3: invisible radiations. Subcommittee, Prof. S. P. Thompson, Prof. Rutherford, and Hon. R. J. Strutt; convener, Prof. Rutherford.

Division 4: heat. Subcommittee, Prof. Callendar and Mr. Horace Darwin; convener, Prof. Callendar.

Division 5: magnetism and electricity. Subcommittee, Prof. S. P. Thompson, Prof. Trouton, and Sir Wm. H. Preece; convener, Prof. Trouton.

Division 6: chemistry. Subcommittee, Prof. Thorpe, Prof. Meldola, Sir Wm. Ramsay, and Sir Alex. Pedler; convener, —.

Division 7: mineralogy and crystallography. Subcommittee, Prof. Miers, Dr. Fletcher, and Mr. L. J. Spencer; convener, Prof. Miers.

Division 8: animal biology. Subcommittee, Sir E. Ray Lankester, Prof. Gotch, Mr. A. E. Shipley, Prof. Poulton, and Dr. Ridewood; convener, Prof. Gotch.

Division 9: vegetable biology. Subcommittee, Lieut.-Colonel D. Prain and Prof. Farmer; convener, Prof. Farmer.

(1) *Exploration of the Land.*

Division 10: geography. Subcommittee, Sir D. Gill, General Sir T. Holdich, Prof. J. Milne, Colonel Sir Charles M. Watson, Colonel Hellard, and Major Close; convener, Colonel Sir C. M. Watson.

Division 11: geology. Subcommittee, Sir Archibald Geikie, Dr. J. J. H. Teall, Mr. F. Rudler, and Dr. F. A. Bather; convener, Mr. F. Rudler.

(2) *Exploration of the Sea.*

Division 12: oceanography and hydrography. Subcommittee, Rear-Admiral Field, Captain Creak, Mr. G. H. Fowler, and Mr. D. J. Matthew; convener, Captain Creak.

(3) *Exploration of the Air.*

Division 13: meteorology. Subcommittee, Dr. Shaw, Dr. Mill, and Major Baden-Powell; convener, Dr. Shaw.

(4) *Exploration of the Heavens.*

Division 14: astronomy. Subcommittee, Sir D. Gill, Sir Norman Lockyer, and Dr. Lockyer; convener, Dr. Lockyer.

Division 15: geodesy. Subcommittee, Committees 10 and 14 sitting together; convener, Major Close.

Division 16: metallography. This additional subsection

has only lately been formed, and should have been included between subsections 6 and 7 (chemistry and mineralogy and crystallography). Subcommittee, Prof. Arnold, Prof. J. A. Ewing, Mr. Walter Rosenhain, and Mr. J. E. Stead; convener, Mr. Walter Rosenhain.

It is hoped that everyone interested in the welfare of science will materially assist the committee, the work of which is a labour of love. Such help, in the form of the loan of objects, photographs, &c., of scientific interest which they may possess, will add greatly to the value of the sections. The conveners of each section will gladly communicate with such intending exhibitors if applications be made to them through the main office (56 Victoria Street, S.W.).

THE EXTINCT VERTEBRATE FAUNA OF PATAGONIA.¹

IF eccentric originality stand for genius, and refusal to follow the beaten track, even when compass-bearings indicate that it is the right one, be deemed merit, then, unquestionably, the author of the work before us is entitled to stand in the first rank of scientific men. If, on the other hand—but perhaps it will be better to leave our readers to complete this sentence as their own judgment dictates after the perusal of the following remarks and criticisms.

Dr. Ameghino was, it seems, engaged on a monograph on Patagonian fossil fishes, when the appearance of an article by Mr. O. Wilckens on the Cretaceous and Tertiary strata of Patagonia led him to direct his attention to the task of confuting the (to him) heterodox views therein expressed. The result is the present bulky volume, which comprises within its purview a survey of the whole of the vertebrate-bearing strata of Patagonia, together with a summary of the author's views with regard to their geological ages and the relationships and phylogenies of their faunas.

So far as vertebrate palaeontology is concerned, Dr. Ameghino has long been imbued with the idea that the Argentine Republic (like Boston in another sense) is the "hub of the universe." In previous works he has demonstrated to his own satisfaction that South America was the birth-place of every mammalian group save that typified by man. He now goes one better, and claims that even *Homo sapiens* himself traces his ancestry to the great South American birthplace and nursery of creation, where he was represented by "*Homo pampeanus*" in the reputed Lower Pliocene strata of Mar del Plata.

There was, however, we are told, a yet earlier forerunner of the human race in Patagonia, to wit, the still apparently unknown *Homosimius* of the Lower Miocene or Oligocene, and it was this hypothetical creature which passed from South America by a land-bridge across the Atlantic, in company with *Cercopithecidae*, to colonise the Old World, where the more bestial man-like apes made their appearance at a later date as a lateral offshoot from the human stock. Finally, to go still further back, the whole order of the Primates (not to mention other mammalian groups) traces its descent to the Argentine Microbiotherium, which the prosaic palaeontologists of other countries persist in regarding as neither more nor less than an aberrant type of opossum. We have thus the direct descent of man from marsupials, in defiance of the accepted view that marsupials and placentals are not in the same line.

The above is merely one example from among many elaborate mammalian phylogenies to be met with in this volume; all, if we may say so, evolved from the author's fertile imagination rather than based on any tangible foundation of fact—or, at least, upon any that is apparent to ourselves.

To put the matter briefly, it may be said that whereas most palaeontologists of repute who have practical acquaintance with the country or its fossils, or with both together, see in the Patagonian sequence a series of

¹ "Les Formations sédimentaires du Crétacé Supérieur et du Tertiaire de Patagonie, avec un parallèle entre leurs Faunes mammalogiques et celles de l'Ancien Continent." By Florentino Ameghino. Pp. 568+plates. Buenos Aires An. Museo Nacional, vol. xv. (1906.)

Cretaceous strata with dinosaurian remains followed, after an interval, by others containing one or two mammalian faunas of apparently Miocene age. Dr. Ameghino recognises in the lower beds a mingled mammalian and dinosaurian Cretaceous fauna, succeeded by several distinct mammalian faunas extending from the Eocene upwards. Nor is this all, for while those who do not accept his views consider that the exclusively Patagonian extinct mammalian fauna (and more especially the Ungulate) is *sui generis* and strictly local, the author is of opinion that the various faunas recognised by himself present numerous ramifying affinities with practically all the other Tertiary faunas of 'the globe, of which, indeed, he regards the former as the *fons et origo*.

It is, however, only fair to add that at the commencement of the volume Dr. Ameghino puts these two irreconcilable views candidly before his readers, and if he elects, in opposition to, practically, the united opinion of the rest of the palaeontological world, to adhere to the second alternative, he has, of course, a perfect right to do so. To attempt to refute his views by summarising and criticising the evidence would manifestly be impossible within the limits of a single short article, and it must accordingly suffice to reiterate emphatically that they are not endorsed by even a respectable minority of expert opinion elsewhere.

It may, however, be well to refer to a couple of instances (in addition to those already cited) of what we venture to call Dr. Ameghino's idiosyncrasies in the matter of classification and phylogeny. European palaeontologists, after very careful study, have arrived at the conclusion that the remarkable Eocene Egyptian ungulate *Arsinoitherium* either represents a special group of the order by itself or that it is an aberrant hyrax. Our author scouts both these opinions, and without any apparent reason refers the genus to the Ancylopora, as typified by the European *Chalicotherium* (*Macrotherium*). Again, if there is one apparently well-established fact in palaeontology it is that the Egyptian *Mœritherium* is on the direct ancestral line of the modern Proboscidea. In this, according to our author, palaeontologists are, however, altogether wrong, and instead of Africa having been the birthplace of the elephants, we are to look for this in South America, whence, by some unexplained magic, various (shall we say imaginary?) genera with almost unpronounceable names blossomed on the one hand into *Palaomastodon* and the elephants, and on the other into the forlorn and childless *Mœritherium*.

To enter into further details would be mere waste of space, and it must suffice to add, in conclusion, that, while fully appreciating the great industry Dr. Ameghino has displayed in collecting and describing the palaeontological marvels of Patagonia, we sincerely regret our inability to accord him that encomium on the results of his labours which it would have been a real pleasure to bestow.

R. L.

HYDROLOGY IN THE UNITED STATES.

WE have been favoured by the Department of the United States Geological Survey with seven¹ more papers on the geology and water resources of various States. Most of these, although containing valuable information on such subjects as underground water supplies, rainfall and stream flow, pollution and its relation to typhoid fever, river experiments as to the measurement of running water, are principally of local interest.

Paper No. 104, on the pollution of the Illinois and Mississippi Rivers by Chicago sewage, by Marshall O.

¹ "The Geology and Water Resources of the Western Portion of the Panhandle of Texas." By C. Gould. Water Supply and Irrigation Paper, No. 101.

² "The Water Supply of Nome Region, Seward Peninsula." By I. C. Holt and F. Henshaw. Paper No. 106.

³ "Underground Waters of the Coastal Plain of Texas." By T. U. Taylor. Paper No. 120.

⁴ "Potomac River Basin." By Parker, Willis, Bolster and Marsh. Paper No. 102.

⁵ "The Quality of Surface Waters in Minnesota." By Wesbraat. Paper No. 105.

⁶ "Water Experiments, Coefficients and Formulas." By R. E. Horton. Paper No. 200. (Washington: Government Printing Office, 1907.)

Leighton, is of much wider interest, containing the particulars of a most searching investigation as to what distance it is possible for the typhoid bacillus to travel in a running stream, and so convey disease from one place to another.

It is well known that the city of Chicago, in order to preserve the purity of the water in Lake Michigan, from which it derives its water supply, diverted the sewage from the lake into a canal thirty miles long for conveying it into the Desplaines river, which connects with the Illinois River, and so with the Mississippi, on which is situated the town of St. Louis. The law authorising the construction of the canal required that the sewage was to be diluted with 20,000 cubic feet of water from the lake per minute for each 1000 inhabitants of the sanitary district.

An epidemic of typhoid fever having broken out in St. Louis, the sanitary authorities were advised that this could be traced to germs transported from Chicago, where a large number of typhoid-fever cases had prevailed. The State of Missouri, in which St. Louis is situated, therefore commenced proceedings in the Law Courts against the State of Illinois and the sanitary district of Chicago for an injunction to prevent further pollution of the Mississippi water. The evidence taken "comprises the best symposium on river pollution, its biological and chemical aspects, and general and special sanitary significance that has ever been assembled." The contentions of both parties were supported by all the most qualified chemists, biologists, and sanitary experts in the United States, no less than forty-one expert witnesses having been called. The record of the evidence occupies 8000 printed pages. The paper now under notice contains a digest of this evidence and the finding of the court.

The distance between the two cities is 322 miles, and there are on the main stream and its tributaries between these two points a population of $1\frac{1}{2}$ million inhabitants. The quantity of sewage discharged from Chicago at the time of the trial was given as 1500 tons daily, and the volume of fresh water sent down with this 300,000 cubic feet a minute. By means of float experiments, most carefully carried out, it was shown that it took nearly eleven days for the water to travel from Chicago to St. Louis.

It was also shown that typhoid fever had prevailed more or less every year for the previous ten years in the towns on the banks of the Mississippi and its tributaries, the number of cases in 1902 amounting to more than 1200, of which 800 occurred in the Chicago district.

One of the most interesting of the experiments made to determine how long a typhoid bacillus would live in a running stream was the discharge into the Mississippi River, just below the junction with the Illinois, of several millions of *Bacillus prodigiosus*, an organism of the same type as the typhoid bacillus, but which had never been found in the Mississippi water. This bacterium was subsequently found in samples collected at different places between the Illinois outfall and the intake of the St. Louis water supply. It was shown that this particular bacillus could live in running water for periods extending from thirty to fifty days, and was still alive when the experiments ceased. Dr. Ravold, who conducted these experiments, testified that it was highly probable that a typhoid bacillus can be carried in a virulent condition a distance equal to that between Chicago and St. Louis. It was admitted that sunlight was detrimental to the life of "bacteria," but the effect depends on the turbidity of the running water and the depth to which it will admit the sun's rays. In the Illinois River the effect of the sun was dissipated in a depth of less than a foot. The factors which cause the disappearance of bacteria are aeration, dilution, sunlight, sedimentation, and absence of food supply.

Cases were brought forward in which it was shown that typhoid fever germs had travelled along a river upwards of fifty-seven miles, and caused infection in water supplies; in another outbreak of typhoid which had been investigated, the distance over which the typhoid germ had been traced as having travelled was 175 miles, and in another 113 miles. It was shown that although the dilution of the Chicago sewage by the clean water

from the lake would render it less injurious, yet this would not destroy the typhoid bacillus or hinder it from travelling down the river.

On the other side it was contended that it had never yet been satisfactorily proved how long the typhoid bacillus will live in the sewage-contaminated water of a stream, but, according to laboratory experiments, the time might be stated as varying between weeks and months. It was held by some experts that typhoid bacilli disappeared when water bacteria became active. As an illustration of this was quoted the fact that the water of the river Spree, which passed through Berlin and received the city sewage, after the course of a few miles widens out into a quiescent body of water. The sewage water entering the lake became so purified that when leaving it was practically as pure as it was above Berlin before it became polluted. The same result happened to the river Limmat, which flows into Lake Zurich.

It was stated also that the river Seine, after receiving the sewage of Paris, purified itself within a distance of forty-three miles.

An elaborate series of experiments was made to determine the longevity of the typhoid bacillus under natural conditions in the water of the drainage canal and other places. The bacilli were placed in parchment sacks suspended in the water by floats, through which substances in solution could pass, but which did not permit the bacilli to pass out. These sacks were suspended in a light cage, and into them was introduced a quantity of sewage, together with a strong culture of typhoid bacilli. The results of these experiments, closely simulating those in nature, indicated that the typhoid bacillus does not survive for a period longer than four days in water similar to that discharged from Chicago.

Experiments made by the witnesses for Chicago as to the survival of the *B. prodigiosus* failed to confirm those of the complainants, and their evidence was to the effect that it was improbable that the organisms reported to have been found at the intake of the St. Louis water were the same as those placed in the drainage canal. It was also stated that, although the typhoid bacillus may remain alive in the human body for many months, and in wet soil some weeks and possibly months, yet in water it dies out quickly, the length of time depending on the character of the water, being longer in pure water than in that which is polluted, where it has to fight for its existence with other bacteria.

The judgment of the Supreme Court of the United States was given in February, 1906, to the following effect:—that the case as presented to the court fell so far below the allegations that it was not brought within the principles heretofore established, and the Bill was therefore dismissed.

UNIVERSITY AND EDUCATIONAL INTELLIGENCE.

CAMBRIDGE.—The thanks of the University are to be given to the Rev. Dr. Bonney, who has presented to the Sedgwick Museum the whole of his collection of rock slices, consisting of two thousand seven hundred specimens, of which the British examples number about thirteen hundred. The latter represent especially the rocks of Cornwall, Charnwood, the Wrekin, the Bunter pebbles, north Wales, Scotland, and the Channel Islands. The European collection contains some four hundred and fifty specimens collected from different parts of the Alps, Brittany, and the Ardennes. There is also a large collection of specimens from the Himalayas, Novaya Zemlya, Ararat, Canada (Eozoon, &c.), Rocky Mountains, Andes, Ecuador, Bolivia, Aconcagua district, Socotra, and the diamondiferous district of South Africa.

Dr. Myers has been appointed university lecturer in experimental psychology until Michaelmas, 1912, and Dr. W. H. R. Rivers university lecturer in the physiology of the senses until the same date.

Mr. A. Hutchinson has been appointed chairman of the examiners for the natural sciences tripos.

The Walsingham medal for 1907 has been awarded to E. Mellanby, formerly research student at Emmanuel College, for his essay on the metabolism of creatinin and

creatin. The Walsingham medal for 1908 will be awarded for a monograph or essay giving evidence of original research on any botanical, geological, or zoological subject, zoology being understood to include animal morphology and physiology.

GLASGOW.—Dr. Charles E. Fawsitt has been appointed to the newly instituted Graham Young lectureship in metallurgical chemistry, and Dr. T. S. Patterson to the Waltonian lectureship in organic chemistry. The endowments for the new lectureships have been provided in part by Mr. Graham Young's trustees, in part by the Carnegie trust, and in part by the old Waltonian foundation.

Mr. F. H. Downie and Mr. F. R. Stewart have been appointed demonstrators in engineering, and Dr. G. H. Clark Muirhead demonstrator in physiology.

The University Court has instituted a new lectureship in psychology, general and experimental. The lecturer will be charged with the equipment and conduct of the laboratory of experimental psychology, for which provision is made in the new buildings of the physiology department, and will also give instruction in educational psychology to teachers in training. The first appointment will be made on December 12. Applicants are referred to the secretary of the University Court for further information.

The following regulations for the final examination for the degree of B.Sc. (pure science), proposed by the faculty of science, were adopted by the Senate on November 7:—

(a) one of the subjects taken by each candidate shall be chosen by him to be the principal subject in his examination, and the remaining two or more shall be considered to be subsidiary subjects; (b) the subsidiary subjects must be, in part at least, cognate to the principal subject, and the examination in them shall also be upon an honours standard, but shall have special regard to those parts of the subjects which are cognate to the principal subject; (c) candidates shall be required to state at the time they enter for the final examination in each subject whether they desire it to be regarded as their principal subject or as a subsidiary subject, and in the event of the latter being the case they shall be required to state which subject they propose to take as their principal subject; (d) in estimating the attainments of the various candidates in any subject, the examiners may take into account the duly attested records of their practical work.

LONDON.—The question of the establishment at South Kensington of an institute for preliminary and intermediate medical studies is being vigorously discussed. For the vacancy on the Senate caused by the resignation of Dr. Lauriston Shaw, three candidates have been nominated, the constituency being the faculty of medicine, composed of teachers of medical subjects who are recognised by the University, to the number of nearly 400. Those candidates are Prof. Starling, of University College; Dr. Norman Moore, of St. Bartholomew's; and Mr. F. C. Wallis, of Charing Cross. The concentration of the teaching of preliminary medical subjects is the principal question now before the electors. It will be remembered that Dr. J. K. Fowler and Prof. Rose Bradford, who formerly represented the faculty of medicine on the Senate, lost their seats on the Senate in a recent election owing to their advocacy of concentration, their places being taken by Dr. Caley and Mr. Leonard Hill.

MANCHESTER.—During the last two years the University has collaborated in the work of the International Committee for the investigation of the meteorological conditions of the upper atmosphere. A kite station has been erected on the Derbyshire moors near Glossop, and the results, which have been supplemented by records obtained with free balloons, have proved most encouraging. Prof. Schuster has now intimated his intention of presenting 500l. to the University in order to make it possible to pursue this work actively. An observer will be permanently stationed on the moor, and, commencing on January 1, 1908, it is intended to send up meteorological instruments daily by means of kites and balloons. The work is to be continued, in the first instance, during one year.

DR. R. T. GLAZEBROOK, F.R.S., will distribute the prizes and certificates and deliver an address at the Sir

NO. 1986, VOL. 77]

John Cass Technical Institute on Tuesday, December 3. The chair will be taken by Sir Owen Roberts, chairman of the governing body. There will be an exhibition of students' work and apparatus in the laboratories, workshops, and other rooms of the institute.

The aggregate number of students at German technical colleges amounted last winter term to 12,000, of whom 2700 were foreigners—that is, about 22 per cent. At the colleges at Dresden, Darmstadt, and Karlsruhe more than one-third of the students were foreigners, and of these 80 per cent. were Russians.

We have received from Prof. V. Karapetoff, of Cornell University, a copy of an interesting paper read by him before the American Institute of Electrical Engineers on the concetric method of teaching electrical engineering. The method he advocates is based on the principle of passing from practice to theory instead of from theory to practice, as is now usual. The study of engineering should, he considers, begin in the freshman year, and be carried throughout four years. Engineering education should be taken up first with a bird's-eye view of actual practice, and not with theory. Auxiliary sciences (mathematics, mechanics, physics, and chemistry) should not be required further than is necessary for the understanding of engineering, and should be given later in the course. Each year of study should be, so far as possible, self-contained, the mental horizon of the student being gradually and concentrically widened. The same author also delivered an address before the New York Electrical Society on the human side of the engineering profession. He argues that the true purpose and value of engineering activity lie in providing better and easier ways for satisfying ordinary human needs. This provides more leisure and opens new possibilities for a higher intellectual development of humanity. The engineer's personal satisfaction consists in knowing this high purpose of his vocation, and in giving his service at maximum efficiency. The other compensation is a result, and not the purpose.

THE final report of the National Association for the Promotion of Technical and Secondary Education has now been published. In accordance with a resolution of its executive committee, adopted at a meeting on March 20 last, the association was wound up on June 30 of this year. The final report takes the form of a brief historical review of the work of the association, and incidentally serves to show the substantial progress which has been made in our national education during the last twenty years. The inaugural meeting was held on July 1, 1887, when the president, the Duke of Devonshire, who served in that capacity throughout the society's existence, took the chair. The association certainly had an excellent record of service. Largely as the results of its activities were passed the Technical Instruction Act and the Welsh Intermediate Education Act in 1889, the Local Taxation (Custom and Excise) Act in 1890, the Technical Instruction (Amendment) Act in 1891, and the Schools for Science and Art Act in 1891, and many administrative improvements were also secured. Several of the association's publications, too, did much to educate public opinion, and among these may be mentioned "Studies in Secondary Education," "A Manual to the Intermediate Education (Wales) Act, 1889, and the Technical Instruction Act, 1889," and the quarterly issues of the *Record of Technical and Secondary Education*. As was only natural, many prominent men of science were from its inauguration closely identified with the association. It will suffice to refer, among many others, to the late Prof. Huxley, to Lord Avebury, Sir William Abney, Sir William Mather, and Sir Henry Roscoe. It is greatly to be hoped that the work so successfully accomplished by the association will be carried on by existing societies of a kindred nature, for, as the Duke of Devonshire remarked at the last annual meeting, a great deal more still remains to be done. The library of the association has been purchased by Sir William Mather, and presented to the Manchester Free Library, and the balance of its funds, amounting to nearly 250l., has been voted to the late secretary, Mr. Frederick Oldman, as an acknowledgment of his services.

SOCIETIES AND ACADEMIES.

LONDON.

Royal Society, February 7.—"Observations on the Life-history of Leucocytes. Part II. On the Origin of the Granules." By C. E. Walker. Communicated by Prof. C. S. Sherrington, F.R.S.

The granules that are so frequently found in leucocytes generally seem to lie scattered quite irregularly in the cytoplasm of the cells in which they occur. In the bone marrow, however, where the leucocytes containing granules are often extremely numerous, a section of properly preserved material will show that the granules are arranged in a more or less definite manner. The granules in these cells, as a rule, oval in shape, and seem to lie in sequence close to each other, so that a line drawn through their long axes would appear as a thread or wire coiled up irregularly in the cytoplasm of the cell. There are many gradations in the regularity of this arrangement of the granules. It varies from a mere suggestion of some of them having been strung together, to a very definite order, and the joining of several end to end. There are again other cells in which a large number of granules join together, forming in places a thick, deeply staining thread, the axis of which is continuous with the axis of the strings of separate granules. From these it is possible to pass by almost insensible gradations to cells where there are no granules, but only a thick thread coiled round the nucleus. From this stage it is again possible to pass to cells where the coiled-up thread occupies a space slightly larger than, or equal to the nucleus, until we arrive at some where it seems to be about the same size in proportion to the nucleus as is the archoplasm in the case of the spermatid. Though it has not been possible as yet to trace the origin of this thread farther, it is strongly suggested that it arises in the archoplasm, which is often seen to be connected with it. During the whole of its existence the thread stains very deeply, and always with the basic in preference to the acid stain. When it has entirely broken up, the granules formed from it still stain in the same manner, but as they begin to lose their regular arrangement so they begin to lose their affinity for the basic stain. These phenomena have only been met with among the cells of the bone marrow. It has been seen that the staining reaction in some at any rate of the granular cells changes from basic to acid; the presence, therefore, of cells containing acidophile and basiphile granules in various proportions is just what one would expect, and is no argument against a common origin of both from the thread here described as occurring in the cells of the bone marrow. The opportunity is taken of pointing out the relationship between the structures which arise from the true archoplasm. Among such structures are the archoplasmic vesicles found in the cells of the testis, which develop into the cephalic cap of the spermatozoon, the similar structures (Plimmer's bodies) which appear in some of the cells in malignant growths, and the granules in leucocytes.

June 27.—"Observations on the Life-history of Leucocytes. Part III." By C. E. Walker. Communicated by Prof. J. B. Farmer, F.R.S.

The author in a previous communication described the occurrence of the meiotic phase and of a number of post-meiotic generations among the leucocytes in vertebrate animals. The number of chromosomes in such cells must, if this occurs, be reduced to one-half of that found in the somatic cells. Such leucocytes will, in fact, have passed through that change which appears to be a necessary prelude to conjugation throughout the animal and vegetable kingdoms. The present paper describes certain phenomena as occurring in leucocytes, and claims that these are most probably to be interpreted as a process of conjugation between individual leucocytes that have passed through the meiotic phase. This conjugation is said to be accomplished in a somewhat complicated manner. The nucleus of one leucocyte sends out a process which penetrates the cytoplasm belonging to itself and to that of the partner in conjugation. This process is in the form of a tube, and through it the linin and chromatin of the one nucleus are drawn into that of the other. The absorption of one cell by another is a well-known phenomenon, but is a com-

paratively simple affair. The absorbed cell is taken into the cytoplasm of the absorbing cell, and is there digested. No nuclear change takes place, and the absorption is apparently carried out in the cytoplasm without the nucleus being directly involved.

It is claimed that the appearance of a special and complex apparatus with no apparent result but the transference of the contents of one nucleus to the other without exposing the contents so transferred to the action of the cytoplasm, shows that some process other than mere absorption of one cell by another is taking place, and that fertilisation is the probable explanation. It is also suggested that this may be a form of fertilisation not hitherto observed in unicellular forms, and that its occurrence among leucocytes is a case of phylogenetic reversion.

Physical Society, October 25.—Prof. J. Perry, F.R.S., president, in the chair.—Magnetic oscillators as radiators in wireless telegraphy: Dr. J. A. Fleming. The paper describes experiments made with flat square coils of various sizes used as magnetic oscillators in the quadrangle of University College, London. In one circuit undamped oscillations were set up by means of a Poulsen arc, and the induced oscillations created in the other circuit at a distance were detected and measured by means of the author's oscillation valve or glow-lamp detector. The distance separating the two circuits was varied from about 50 feet to 250 feet. Curves were obtained showing how the secondary current varied with the distance of the circuits apart and with their relative position. It was shown that the inductive effect was greatest when the flat coils were in a horizontal position and at a certain distance above the earth. The law of variation with distance proved to be something between the inverse cube and the inverse square of the distance. It was then shown that increase in size of the coils had a very marked action in increasing the inductive effect, and also that for equal power the use of the spark method, creating intermittent oscillations in the primary, gave better effects than the use of the arc or undamped oscillations. It was also shown that for the coils used the true radiation of energy was very small, and therefore that the distance effects obtained were almost entirely due to magnetic or Faradaic induction. Suggestions were then made for increasing the efficacy of the ordinary inductive type of wireless telegraphy by the use of high-frequency oscillations in the primary circuit, and a suitable detector such as the author's oscillation valve combined with a telephone as a receiver in the secondary circuit. Such a method would have a far greater reach than the ordinary low-frequency alternating current inductive telegraphy, and not be open to the objection of disturbing commercial telephonic circuits.—The use of variable mutual inductances: A. Campbell. In connection with wireless telegraphy, the measurement of small inductances and capacities is of importance; one of the methods described has special reference to small self-inductances. Mutual inductances can be more easily dealt with than self-inductances, for the former can be (1) more accurately calculated from dimensions; (2) are less affected by change of frequency; and (3) when variable can be made to pass through zero value. A convenient form of variable mutual inductance consists of a continuously variable part and a series of steps. The first consists of two equal parallel coils with a third coil moving parallel to their planes round an axis eccentric to the fixed coils. The scale thus obtained is very open near zero (which is an advantage), and the graduation is done by experiment, a theoretical discussion being given in an appendix: The steps are obtained by means of another fixed coil of stranded wire, each strand giving an equal subdivision. The model shown had two ranges, from 0.01 up to 200 and 2000 microhenries.

Entomological Society, November 6.—Mr. E. Saunders, F.R.S., vice-president, in the chair.—*Exhibits*.—A. H. Jones: A specimen of the longicorn beetle *Acanthocinus aedilis*, L., a Rannoch species, found in Gray's Inn Road.—Dr. F. A. Duxey: ♂ and ♀ specimens of a new Pincopleteryx, discovered by Mr. S. A. Neave in northern Rhodesia. The ♀ resembled that of *P. rubrobasalis*, but the ♂ was quite distinct. Both sexes of *P. rubrobasalis* and the female sex of Mr. Neave's species were mimics

of *Mylothris agathina*.—**W. G. Sheldon**: A series of *Limentis populi* and *ab. tremulae* with intermediate forms taken this year near Laon, and a series of *Chrysophanus hippothoe* from the same region, the females displaying a wide range of variation for so restricted a locality as that in which they were captured.—**G. C. Champion**: A fully developed example of *Mesovelia furcata*, M. and R., from Slapton, south Devon, and *Thaumorrizon cinereus* from Lynmouth, north Devon.—**A. Harrison and Hugh Main**: A case of *Aplecta nebulosa*, arranged to show the great range of variation of this species in Delaware Forest, with series from Epping Forest, north Cornwall, and the New Forest for comparison.—**R. S. Mitford**: (1) Two ♂ specimens of *Cryptocephala bipunctatus*, taken by him at Niton, in the Isle of Wight, in July, these being two forms of varieties well known on the Continent, but hitherto found in Britain; (2) *Paracynus aeneus*, captured on the north Essex coast in June, 1868, thus establishing the claim of *P. aeneus* to be regarded as a British beetle; (3) an example of the very rare *Lathrobium rufipenne*, taken at Niton, Isle of Wight, in July, 1906, a specimen of the rare *Ceuthorrhynchus viduatus*, taken by him at Brading, Isle of Wight, in July, 1907, and a specimen of *Cis dentatus*, taken at Sandown, Isle of Wight, in July, 1906; this species, although well known on the Continent, had never before been recorded in Britain.—**Papers**.—A large series of Nycteribiidae (parasitic Diptera) from Ceylon; **J. E. Collin**.—(1) Some butterflies taken in Jamaica; (2) some butterflies of Tobago; **Dr. G. B. Longstaff**.

GÖTTINGEN.

Royal Society of Sciences.—The *Nachrichten* (physico-mathematical section) contains the following memoirs communicated to the society:—

March 9.—The uniformisation of real algebraic curves: **P. Koebe**.

May 11.—The uniformisation of given analytic curves: **P. Koebe**.—The radio-activity of the air over the open sea. **C. Runge**.—Researches from the Göttingen University chemical laboratory, xvii.:—(1) on oxygenated derivatives of sylvestrene; (2) on nopinone; (3) on the synthesis of higher homologues of terpin and of higher homologous terpenes: **O. Wallach**.—Contribution to the theory of undamped electric oscillations in gas discharges: **E. Riecke**.—Numerical survey of the near and remote earthquakes registered at the Samoa Observatory during 1906: **F. Linko**.

July 6.—The effect of light upon the formation of sulphuric acid: **A. Coehn**.—The class enumeration of the *Körper* of complex multiplication: **R. Fueter**.

July 7.—The boundary values in the case of the differential equation $\Delta\Delta U=0$: **A. Haar**.

DIARY OF SOCIETIES.

THURSDAY, NOVEMBER 21.

ROYAL SOCIETY, at 4.30.—The Interaction of Mercury with Alloys of Other Metals: **Dr. J. W. Mallet, F.R.S.**—Note on the Sensibility of the Ear to the Direction of Explosive Sounds: **A. Mallock, F.R.S.**—On the Silver Voltmeter: Part I. A Comparison of Various Forms of Silver Voltmeters: **F. E. Smith**, and a Determination of the Electrochemical Equivalent of Silver: **F. E. Smith and T. Mather, F.R.S.**—Part II. The Chemistry of the Silver Voltmeter: **F. E. Smith and Dr. T. M. Lowry**.—On the Normal Weston Cadmium Cell: **F. E. Smith**.—On a Method of Depositing Copper upon Glass from Aqueous Solutions in Thin Elasticity Resonance Film, and thus Producing a Copper Mirror: **Dr. F. D. Chataway, F.R.S.**—On Luminous Efficiency and the Mechanical Equivalent of Light: **Dr. C. V. Drysdale**.—The Dispersion of Double Refraction in Relation to Crystal Structure: **Dr. T. H. Havelock**.

CHEMICAL SOCIETY, at 8.30.—The Interaction of Metallic Sulphates and Caustic Alkalies: **S. P. U. Pickering**.—The Chemistry of Bordeaux Mixture: **S. P. U. Pickering**.—Aromatic Azoimides, Part III. The Naphthylazoimides and their Nitro-derivatives: **M. O. Forster and H. E. Pritz**.—Studies of Dynamic Isomerism. Note on the Action of Carbonyl Mirror: **Dr. F. D. Chataway, F.R.S.**—On Luminous Efficiency and the Mechanical Equivalent of Light: **Dr. C. V. Drysdale**.—The Dispersion of Double Refraction in Relation to Crystal Structure: **Dr. T. H. Havelock**.

INSTITUTION OF MINING AND METALLURGY, at 8.

LINNEAN SOCIETY, at 8.—Abnormal Structures in Leaves, and their Value for Morphology: **W. C. Worsdell**.—Specimen-preservation in Australian Mammals: **J. G. O. Tepper**.—Revision of the Genus *Hilgeria*, Blume: **S. T. Dunne**.—*Phyllis*—Luminous Larva from British Guiana: **C. W. Anderson**.—Living Specimens of Peripatus, from South Africa: **Prof. A. Dendy**.—*Linaria verna*, and other British Plants: **G. C. Druce**.

FRIDAY, NOVEMBER 22.

PHYSICAL SOCIETY, at 5.—On Singing Sand from New England; **S. Skinner**.—Exhibition of a Micromanometer: **L. Baird**.—A Diabolo Experiment: **Vernon Boys**.—Exhibition of a Gyroscope illustrating Brennan's Monoaxial: **Prof. H. A. Wilson**.

MONDAY, NOVEMBER 25.

ROYAL GEOGRAPHICAL SOCIETY, at 8.30.—The Exploration of the Nun-Kun Mountain Group and its Glaciers: **Dr. W. Hunter Workman**.
SOCIOLICAL SOCIETY, at 8.—The Psychological Origin of Religion: **Prof. J. H. Leuba**.
SOCIETY OF ARTS, at 8.—The Theory of the Microscope: **Conrad Beck**.
INSTITUTE OF ACTUARIES, at 8.—On the Valuation of Staff Pension Funds, Part II. Widows' and Children's Pensions (continued): **H. W. Manly**, with Tables by **W. A. Workman**.—A Pension Fund Problem; with some Remarks on the Deduction of Salary-scales: **J. Bacon**.

TUESDAY, NOVEMBER 26.

ZOOLOGICAL SOCIETY, at 8.30.—On some New and Little-known Araneida: **Rev. O. Pickard Cambridge, F.R.S.**—Descriptions of New Species of South-American Cryptocephalini: **M. Jacoby**.—A Monograph of the Chiropteran Genera *Uroderma*, *Enchisthenes*, and *Artibeus*: **Dr. K. Andersen**.—Environmental Studies on the Limpet: **E. S. Russell**.—Contributions to the Knowledge of the Anatomy of the Batrachian Family Pelobatidae: **F. E. Bedford, F.R.S.**—On the Microlepidoptera of Tenerife: **Lord Walsingham, F.R.S.**—Dates of Publication of the Separate Parts of Gmelin's Edition (thirteenth) of the "Systema Naturæ" of Linnaeus: **J. Hopkinson**.

INSTITUTE OF CIVIL ENGINEERS, at 8.—The Tramway Bay Development Works: **S. H. Ellis**.

WEDNESDAY, NOVEMBER 27.

BRITISH ASTRONOMICAL ASSOCIATION, at 5.—Address by **Sir David Gill, K.C.B., F.R.S.**
SOCIETY OF ARTS, at 8.—The Franco-British Exhibition, 1908: **Sir John A. Cockburn, K.C.M.G.**

THURSDAY, NOVEMBER 28.

INSTITUTE OF ELECTRICAL ENGINEERS, at 8.—The Development of Turbo-Generators: **Dr. Robert Kohl**.

FRIDAY, NOVEMBER 29.

SOCIETY OF ARTS, at 8.—The Hygiene of Work in Compressed Air (Diving, Caisson Work, Sub-aqueous Tunneling, &c.): **Dr. J. S. Haldane, F.R.S.**

CONTENTS.

	PAGE
Modern Science and American Technology	49
The Philosophy of a Biologist	51
The Hamburg Expedition to South-Western Australia. By J. W. G.	51
Our Book Shelf:—	
Neinst: "Experimental and Theoretical Applications of Thermodynamics to Chemistry"; Arndt : "Technische Anwendungen der physikalischen Chemie."— H. M. D.	52
Helmert: "Die Ausgleichsrechnung nach der Methode der kleinsten Quadrate"	52
Molisch: "Die Purpurbakterien. Eine mikrobiologische Studie."— Prof. R. T. Hewlett	53
Allison: "The Case of Existence"	53
Moffatt: "Science German Course"	53
Letters to the Editor:—	
The Wehnelt Kathode in a High Vacuum.— Frederick Soddy	53
The Interpretation of Mendelian Phenomena.— J. T. Cunningham ; G. Archdall Reid	54
The Winding of Rivers in Plains.— R. D. Oldham	55
"Magic Mirror" Effects.— Douglas Carnegie	55
Notes on Ancient British Monuments. I. (Illustrated.) By Sir Norman Lockyer, K.C.B., F.R.S.	56
Plague and Fleas. By J. W. W. S.	59
The International Association of Seismology	60
Sir F. L. McClintock, K.C.B., F.R.S.	61
Notes. (Illustrated.)	62
Our Astronomical Column:—	
A Large Solar Prominence	66
Mellish's Comet, 1907	66
Mars as the Abode of Life	66
Saturn's Rings	67
Elements and Ephemeris for the Minor Planet <i>Patroclus</i>	67
Comparisons of the Places of Mars for the Oppositions of 1907 and 1909	67
Science at the Franco-British Exhibition of 1908	67
The Extinct Vertebrate Fauna of Patagonia. By R. L.	68
Hydrology in the United States	68
University and Educational Intelligence	69
Societies and Academies	71
Diary of Societies	72

THURSDAY, NOVEMBER 28, 1907.

THE VERTEBRATE NERVOUS SYSTEM.

The Nervous System of Vertebrates. By Prof. J. B. Johnston. Pp. 370. (London: J. Murray, 1907.) Price 15s. net.

THE author's aim has been "to produce a text-book of comparative neurology, giving an account of the nervous system as a whole, to trace its phylogenetic history, and to show the factors which have determined the course of evolution." He states (in the preface) that the functional point of view is the chief characteristic of the present work, but that (p. 10), as an introduction to the study of the nervous system, it deals chiefly with structure.

The work starts with a brief, though clear, summary of the various methods used in the investigation of the nervous system, and then proceeds to a very useful description of the general morphology of the same, more particularly as found in the Cyclostoma, Selachians, and Amphibia. Then follows a lucid account of the main features and processes in the development of the nervous system, especially as seen in the lower vertebrates, and valuable light is thrown on the evolution of those parts of the nervous system associated more directly with the visceral arches, spiracular and branchial clefts, and of the lateral line structures. We note the author, without hesitation, ascribes taste, or gustatory, functions to structures distributed more or less widely on the outside of the head, and in extreme cases, as in some bony fishes, on the fins and over almost the entire body, yet the true and specific function of these organs remains still to be determined.

In a brief description of the nerve elements and their functions the formulation of the neurone theory is ascribed (p. 10) to Waldeyer, in 1891, whereas this distinguished savant did little more than suggest the term "neurone" for structures the conceptions of which in this connection had been gathering strength since the days of Schleiden and Schwann, some fifty years earlier.

In discussing nerve degeneration and regeneration the author *inter alia* states (p. 90) that the proximal portion of a divided peripheral nerve remains in a healthy condition. This may be true for some of the lower vertebrates, but is incorrect for many of the higher forms, as v. Gehuchten and others have proved.

In chapters v. to xii. the author discusses with much originality and lucidity the four kinds of nervous activity, viz., the somatic afferent, somatic efferent, visceral afferent, and visceral efferent, and these chapters, together with that on the evolution of the cerebral hemispheres, may be accounted some of the most valuable in the book. The description of the neuromasts is especially useful, and though on debatable and obscure ground the whole matter is suggestively and clearly treated. However, the author not infrequently falls into the common error of confusing or using indiscriminately the term "afferent" and "sensory," and throughout the work seems more at

home with the subject as it concerns the lower than with that of the higher vertebrates, especially in connection with recent work.

Perhaps, too, reference may be made to the following assertions:—On p. 110 it is stated that "sensory cutaneous fibres emit collaterals which cross directly to the opposite side of the spinal cord." These crossing fibres have never yet been shown degenerated in a mammal, and the statement is incorrect for at least the majority of the higher vertebrates. Again, on p. 115 it is stated that "a part of the secondary neurones of the V. nerve ascend on the same side of the body," whereas recent work tends to show the contrary, at least in mammals.

In the description of the cerebellum several statements call for modification. Thus it is stated, p. 240, that "all three peduncles of the cerebellum carry both incoming and outgoing fibres," whereas many recent workers on higher vertebrates have shown the inferior cerebellar peduncle to contain only afferent fibres. Again, on p. 243, it is stated that "primary somatic sensory fibres from spinal roots enter the cerebellum directly." On p. 245 that "the direct cerebellar tract from Clarke's column ends, according to most observers, in the deep grey nuclei of the cerebellum" (instead of in the cortex of the vermis); and on the same page that "the axones of the Purkinje cells pass to the spinal cord and inferior olive," and that "the fibres passing to the Nucleus Dentatus seem to include fibres from the posterior column nuclei." With all of these statements we are in disagreement, and naturally, therefore, with deductions drawn therefrom. Moreover, we regret in the account of the cerebellum the absence of reference to the views of Hughlings Jackson, or to the recent work by Sherrington, whilst the general conception that the cerebellar cortex is a large recipient surface for afferent impulses from all parts of the body; that this gives off its efferent impulses along the fibres to the cerebellar nuclei, and these gain efferent impulses to the bodily structures as advocated more particularly by Clarke and Horsley, Déjerine, Thomas, Klimoff, &c., seems insufficiently emphasised.

The last chapter offers briefly a review of the more important facts concerning the neopallium, and would have been more useful had it in the discussion of the sensori-motor areas treated of such sub-divisions as the audio-sensory, audio-psyche, visuo-sensory, and visuo-psyche, which are not mentioned; and had the motor area not been depicted as involving the post-central gyrus which Grünbaum and Sherrington disproved for Anthropoids, and many surgeons have disproved in man.

On the whole, the book gives the impression of having been written by an able zoologist interested in neurology, rather than by a pure neurologist, and therein lies a good deal of its value. No more abstruse problem has ever been presented to man than that of the vertebrate nervous system, and in the present work the author presents a very readable and succinct account of his subject, which forms a valuable and welcome addition to the literature relating to it.

W. PAGE MAY.

E

ELECTRIC POWER AND TRACTION.

Electric Power and Traction. By F. H. Davies. Pp. vi+293. (London: A. Constable and Co., Ltd., 1907.) Price 6s. net.

ELECTRIC power and traction is such an immense subject that it is rather a bold undertaking to deal with it in a small volume of 293 pages, even if the reader is supposed to know the elementary laws of electrical engineering. The book, however, does not pretend to be a regular text-book, but it is evidently intended for those whose knowledge of electrical engineering is limited, and to these as well as students it can be recommended.

Four chapters deal with the generation and distribution of power. The various systems of direct and alternating current are briefly discussed, and descriptions of typical installations are given. As the author briefly touches upon the subject of direct-current high-tension transmission, it is rather surprising that no mention is made of the Thury system, which has come into prominence during the last few years.

Two chapters are devoted to D.C. and A.C. motors, and their principles are expounded. In directing attention to the starting-up of induction motors, the author omits to mention the important method of changing from "star" to "delta" on the stator, which is used for most squirrel-cage motors up to 20 horse-power.

The chapters on the application of electric power are the best in the book, and the advantages of electric driving are clearly brought out. On p. 124 there appears a statement which shows that, in the author's opinion, the time is not far distant when the voltage for lighting ships will be raised to 200 or 240, but this prediction will not command universal assent. The modern tendency even on shore is to return to 110 volts, especially since the introduction of metallic filament lamps, and it seems more probable that 100 or 110 volts will remain the standard voltage for marine work.

The last ten chapters of the book are devoted to electric traction, and although one may find in them a few statements which are open to criticism, they contain a good deal of practical information. The conduit and surface-contact systems are dealt with, and the advantages of electric traction are briefly set out. Full details are given of the direct-current system in use on the Metropolitan, District and London tube railways. The benefits of "multiple-unit control systems" are briefly touched upon. In view of the prominence given to the Westinghouse control system, it is surprising that no mention is made of the British Thomson-Houston system, the more so as the latter is in use on nearly all the London tubes and underground railways.

In his remarks on substations the author, in dealing with motor-generators, has omitted to mention Bruce Peebles' motor-converters, which in recent years have come largely into use, notably on the Great Western Railway, where it is the standard equipment for all substations.

On p. 240 the novel statement appears that the middle rail on the Metropolitan and District railways

is not protected, "because it is practically at earth potential." Perhaps if the author would try it, by touching it, he might change his opinion.

The exposition of the *pros* and *cons.* of three-phase, single-phase, and D.C. systems is not absolutely convincing, because, to judge from the disproportionately numerous descriptions of single-phase locomotives, it would almost seem that the author has an unduly high opinion of this system. It might have been of interest if particulars had been given of the New York Central locomotives, as they represent the most recent practice in D.C. traction, and surpass anything that has been done, so far, with the single-phase system. The book is well printed, and illustrated by excellent photographs. It contains a good deal of sound practical information, and can be recommended to the class of readers for whom it is intended. L.C.

SCHOOL CHEMISTRY AND PRACTICAL ORGANIC CHEMISTRY.

The Complete School Chemistry. By F. M. Oldham. Pp. viii+416. (London: Methuen and Co., 1907.) Price 4s. 6d.

Practical Chemistry for Army and Matriculation Candidates. By Geoffrey Martin. Pp. viii+144. (London: Crosby Lockwood and Son, 1907.) Price 2s. net.

Systematic Practical Organic Chemistry. By G. M. Norman. Pp. viii+98. (London: W. B. Clive, University Tutorial Press, Ltd., 1907.) Price 1s. 6d.

A Course of Practical Organic Chemistry. By T. Slater Price and D. F. Twiss. Pp. xiii+239. (London: Longmans, Green and Co., 1907.) Price 3s. 6d.

A Scheme for the Detection of the More Common Classes of Carbon Compounds. By F. E. Weston. New edition. Pp. viii+95. (London: Longmans, Green and Co., 1907.) Price 2s. 6d.

MR. OLDHAM'S book provides a complete course of instruction for schools. He has had in view the London matriculation and the Army entrance examination, but has added important sections not included in either syllabus, which he says with a touch of irony "should be taught wherever a teacher is free from the trammels of an examination syllabus and need think only of giving sound instruction."

Judging from a general survey of the book, we are inclined to think that the syllabuses above mentioned were not altogether present in the author's mind when he wrote it, for sound instruction is certainly the keynote of his method.

Part i. especially is excellently arranged, clearly written, and admirably illustrated. If the school time admitted of it one could not devise a better course for the beginner in chemistry; but the standard eventually reached is far beyond that of any matriculation candidate, and one is doubtful if even three school years would suffice to cover the ground mapped out, unless, indeed, the experimental part were performed for, instead of by, the student, which would be a misfortune. The programme is an ambitious one; but we believe it is thoroughly sound, and if it could be

begun at school and carried to the end of part i. slowly and methodically, it would form an excellent groundwork for a subsequent college course.

There is little to criticise. Attention should be directed to one omission which is not uncommon in elementary text-books. It states on p. 40 that "you have found out that hydrogen is contained in acids." It is quite true that hydrogen is described as being obtained by the action of acids on metals, but there is no suggestion as to where the gas comes from, and, so far as any information to the contrary goes, it might just as well come from the metal. Some explanation or comment is called for, because a few pages further on the action of acids on carbonates is described, and in this case the process appears to be reversed, the gas coming from the solid and not from the acid.

We should like to see electrolysis entirely banished from elementary books. The decomposition of water by the current is a mysterious and unconvincing experiment. It is difficult to understand why the gases appear at the ends of two different platinum wires, and why the volumes which collect should represent the true composition of the liquid. The union of the two gases to form water by means of the electric spark only serves to heighten the mystery. A careful drilling in these two operations gives the schoolboy an agent which in his imagination will produce or decompose every compound gas that ever existed, and he uses this knowledge, as we all know, with a reckless facility. It is a satisfaction to find that Lavoisier did, as we are generally told, institute experiments to prove the conservation of matter, but, as the author states, did several experiments which showed it. Lavoisier simply took the principle for granted, as most chemists had done before him, from Boyle onward. Dalton, by the way, was not exactly a schoolmaster in Manchester, though he served in that capacity at Kendal.

The attractive appearance, substantial get-up, and exquisitely drawn diagrams of Dr. Martin's book command at once a careful perusal. It differs essentially from the foregoing in confining itself to the practical, or, perhaps more strictly, to the manipulative side of chemistry. Each experiment stands alone, and has no necessary connection with the one that precedes or follows it, minute directions being given for its performance. It is also for Army and matriculation candidates, and will no doubt prove very useful to both candidate and teacher as a laboratory *vide mecum*.

Mr. G. M. Norman's "Systematic Practical Organic Chemistry" is one of the organised science series, and is intended to meet the requirements of stages i. and ii. of the Board of Education examination. It contains a description of a series of simple preparations and a variety of useful tests. It is satisfactory to find that the Board of Education now requires evidence that the candidate has carried out a number of preparations before presenting himself. It is to be hoped that before long the Board of Education will take the further step of requiring the evidence without the candidate. No kind of chemistry lends itself to a two or three hours' practical examination, organic

chemistry perhaps least of all, and the evidence of knowledge elicited by the sort of experiment set at these examinations has very little value. That, however, does not impair the usefulness of the book under review, which may be safely commended both for the purpose it is intended to fulfil and also as an introduction to practical organic chemistry.

Messrs. Price and Twiss's "Practical Organic Chemistry," like the preceding volume, owes its origin to the new syllabus of the Board of Education, and is intended to meet to some extent the requirements of stage iii. (theoretical organic), as well as to prepare for stages i. and ii. (practical organic) of the Board's examination. The treatment of the subject is full and comprehensive. It contains the usual series of simple preparations, an account of the qualitative and quantitative examination of organic compounds, molecular-weight estimations, and useful schemes of analysis. Without introducing any specially novel features, it presents a fairly complete programme of practical study which if carefully carried out should form a sound basis for subsequent research in organic chemistry. The descriptions are clear and concise, and the illustrations, though not numerous, are probably sufficient for the purpose. It may be recommended as a thoroughly safe book for the laboratory.

Mr. Weston's book on the detection of organic compounds deals, as it states, with qualitative methods only. That such a book should have reached a second edition and should serve the needs of the final B.Sc. of the London University and of the honours stage of the Board of Education is a hopeful sign of the times, if we must have this kind of test. Such defects as the book possesses, and they are not numerous, are to be attributed to the fact that it is written to meet the requirements of a practical examination where time is an important factor.

The author confines his attention to the study of pure organic substances only, giving directions which, if carefully followed, should lead to their detection, and at the same time to the acquisition of much useful information and manipulative skill on the part of the student.

This is all thoroughly sound and satisfactory so long as it is recognised that it is an introduction to analysis, and that the real laboratory problems involve such things as the separation of mixtures and the purification of impure products. It appears from a general perusal of the book that some of the directions need amplifying. This refers more particularly to the means of ascertaining the presence of oxygen, upon which the grouping of the compounds is based, to the identification of aromatic hydrocarbons (p. 12), to Fenton's oxidation method for detecting ketohexoses (p. 47), and to Fischer's benzaldehyde green reaction for aldehydes (p. 40). We would also suggest the following additions or modifications in a future edition:—the use of bromo- and nitro-phenylhydrazine, methyl sulphate and semicarbazide as useful reagents and of Tollens' reagent (the name, by the way, is spelt with an "s") for pentoses, also the consistent use of the modern system of nomenclature and a good index.

J. B. C.

OUR BOOK SHELF.

Vergleichende Morphologie der Pflanzen. I. Theil, mit 200 i.d. Text gedr. Abbild. u. zwei lith. Doppeltafeln. By Dr. Jos. Velenovský. Pp. 277+plates. (Prag: Fr. Rivaňec, 1905.)

DR. VELENOVSKÝ has written the earlier portion of a work which will be found of no small interest to botanists, not only because the author has brought together a number of new observations of his own, but because he deals with the whole mass of facts from a definite point of view. Probably, as he himself hints in the preface, his views may not command general acceptance, and we confess to experiencing a certain sense of disappointment after reading the book. The point of view which the author adopts is, it seems to us, too rigid and formal. Morphology has really outgrown the stage of pure formalism. We have come to recognise that the task of trying to understand why and how development has followed on the lines one can actually trace, is overshadowing the purely formal abstractions which used to constitute morphology.

Twenty years ago it was the fashion to divorce physiological notions from morphological concepts. At the present time, probably most botanists have an inkling, if not a conviction, that morphological "laws" really do resemble those of the Medes and Persians. The "laws" in both cases last just so long as they can continue to be tolerated. With increased knowledge the bonds of the old laws are loosened, and fresh working theories become needed to comprehend the increased range of intellectual vision.

But it must not be thought that the foregoing remarks are intended to depreciate the value of the book before us, for it appears to us to be one that can be read with considerable interest and profit. Much of the author's railing against certain practices which are not uncommon at the present time is justifiable, although he is apt perhaps to overstate the case.

"In modern times hardly anything but a monograph is appreciated; each author is acquainted with his own particular genus, or it may be, family, and he cares for nothing else. . . ."

But when Dr. Velenovský leaves generalities and comes to closer quarters with his subject-matter, he is on ground where he will meet with less opposition, albeit his methods may awaken some surprise. In these days laborious description of anatomical detail too often replaces an attempt to give a comprehensive account of the plants themselves. The author, however, scarcely devotes any space at all to internal structure, and finds room thereby to give a more complete account of the range of external variation within the cryptogamic groups to which this volume is devoted; and it is not impossible that some of his readers may experience a kind of mild shock at finding many unfamiliar forms included in a group which they have hitherto only known through one or two laboratory "types."

The book contains many new illustrations, and it is not unlikely to meet with a better reception than its author seems to think it will obtain. J. B. F.

De Vormen der Aardkorst: Inleiding tot de Studie der Physiographie. By J. van Baren. Pp. viii+232. (Groningen: J. B. Wolters, 1907.)

This little book attempts, in the course of 207 pages, to cover the whole ground of physical geology, and to give an account of the most important observations and discoveries made in this branch of science up to the year 1905. It is necessarily, therefore, somewhat sketchy, but ample compensation for this will be found in the freshness of its information, whether conveyed by illustrations or letterpress. The illustrations are

particularly good, and the only one which strikes us as distinctly old-fashioned is the diagram showing the distribution of seismic areas.

In the opening pages the student is introduced to the meaning of elementary technical terms, with their equivalents given in English, French, and German. These would be more useful if they were more exact; the English for "Streichen" is not "direction," but "strike," and an "overthrust" is not identical with either an inclined or a recumbent fold. It is singular that many Continental geologists, notwithstanding their apparent familiarity with the structure of north-western Sutherland, should still seem to find a difficulty in grasping the real significance of our "overthrust."

The author does not attempt to found any system of his own, and in disputed questions generally contents himself with summarising the opinions of others; hence, in treating of the internal state of the earth, the important bearing of recent seismological observations is overlooked, for if distortional waves do really traverse the whole mass of the planet, we need no longer give serious attention to theories which involve a gaseous interior.

The origin of coral atolls is briefly discussed, and the boring in Funafuti is referred to as furnishing a proof that in certain cases Darwin's theory holds good; on the other hand, it is asserted that this theory will not apply to the atoll-like reefs of the West Indies. This latter statement would seem to show that the author cannot have read Darwin's "Coral Reefs" with sufficient care, for Darwin himself expressly excluded these reefs from his explanation. In this oversight, however, the author by no means stands alone.

To the general reader, whose interest is restricted to results, this work will provide a useful epitome, nor is it without a claim upon the advanced student; it brings together many new facts hitherto scattered and disconnected, and builds them into the edifice of his science.

Nests and Eggs of Birds found Breeding in Australia and Tasmania. By A. J. North. Vol. ii., part ii. (Australian Museum, 1907.)

THIS part of the second volume of the new edition of Mr. North's excellent work on the nests and eggs of the birds found breeding in Australia and Tasmania describes the greater portion of the large and important family Meliphagidae, commenced towards the latter end of the preceding part, and the families Nectariniidae, Zosteropidae, Dicædæ, and Pardalotidae. The figures of the eggs, which are of the natural size, were reproduced by heliotype process at the Government Printing Office from photographs of specimens. The letterpress contains descriptions of the birds, their nests and eggs, and a general account of their life-history. The excellent detailed description of the birds, the copious field notes, and the beauty of the illustrations all call for notice. This important and most interesting work is a publication of the Australian museum, beautifully produced, and at a very low price. In the present part we have 138 pages of letterpress (large 4to), three plates (one showing the nest of Lewin's honey eater *in situ*, and the other two comprising sixty-six figures of eggs), besides illustrations in the text of birds, nests, and breeding haunts, for 7s. 6d.

Grundzüge der Tierkunde für höhere Lehranstalten. By Prof. Karl Smalian. Pp. 304; illustrated. (Leipzig: G. Freytag; Vienna: E. Tempsky, 1907.) Price 4 marks.

This work, which is intended as a companion to the author's "Grundzügen der Pflanzenkunde," is more attractive than the generality of school text-books on

account of being illustrated by thirty coloured plates, which are excellent examples of the three-colour process. Not only are they for the most part good pictures of the animals they purport to represent, but they also show in most cases the natural surroundings of the respective species, so far as these can be reproduced with fidelity to nature. Unfortunately, in one instance that has come under our notice the wrong species has been depicted. We refer to the plate of giraffes and zebras facing p. 42, where the animal purporting to be the true or mountain zebra (*Equus zebra*) is the northern race of the bonte-quagga, or Burchell's zebra (*Equus burchelli granti*). Had the true zebra been depicted, the plate would then have been wrong, as showing a mountain animal on the open plains. The text includes a brief but well-compiled survey of the whole animal kingdom, from Primates to Protozoa, including sporozoans, with some mention of extinct forms, and the work as a whole appears thoroughly suited to its purpose.

R. L.

Précis des Caractères génériques des Insectes, disposés dans un Ordre naturel par le Citoyen Latreille. A Paris, chez Prévôt, Libraire, Quai des Augustins, et à Brive, chez F. Bourdeaux, Imprimeur Libraire. A Brive, de l'Imprimerie de F. Bourdeaux, au 5 de la R. [1796]. Pp. xiv+208. (Imprime à 200 Exemplaires par A. Hermann, n.d.) Price 7 francs.

This is a reprint of a very rare book, which is seldom to be found even in the best entomological libraries. It commences with a table of the fourteen classes into which the author divides insects (understanding by that term Arachnida, Crustacea, and Myriopoda, as well as Hexapoda), followed by systematic characters for 351 genera recognised by Latreille, one or two others, described by other authors, being passed over as at present unknown to him. Several very familiar genera, such as *Ypsolophus* and *Adela*, are characterised in this book for the first time, but without indication of types, for which reference must be made to Latreille's later works. It is always unsatisfactory to entomological authors to be in doubt respecting the actual contents of a book they only know at second-hand, and we are glad that this scarce book has now been rendered accessible to them in a complete (and, we hope, accurate) reprint.

The Metric and British Systems of Weights, Measures and Coinage. By Dr. F. Mollwo Perkin. Pp. 83; with 17 diagrams. (London: Whittaker and Co., 1907.) Price 1s. 6d.

DR. PERKIN here provides a simply written and clearly expressed account of metric measures of length, area, volume and weight, and, in addition, treats of specific gravities, temperature measurements, and money. As Lord Kelvin has said, "our weights and measures are time-wasting and brain-wearing," and all attempts to familiarise British boys with the simplicity and convenience of the decimal system deserve encouragement. This small volume should prove useful in both day and evening schools, and all engaged in manufacture and commerce would derive advantage from its study.

The Story of Scraggles (A Sparrow). By George W. James. Illustrated from drawings by Sears Gallagher and from photographs. Pp. 88. (London: Chatto and Windus, 1907.) Price 2s. 6d.

THE greater part of this booklet is in the form of the autobiography of an ailing song-sparrow, which could not fly, and was kept in a house for three months. The story, which purports to represent the bird's thoughts and feelings, will probably appeal to little girls, and encourage them to be kind to animals.

NO. 1987, VOL. 77]

LETTERS TO THE EDITOR.

[The Editor does not hold himself responsible for opinions expressed by his correspondents. Neither can he undertake to return, or to correspond with the writers of, rejected manuscripts intended for this or any other part of NATURE. No notice is taken of anonymous communications.]

Specific Stability and Mutation.

MR. R. H. LOCK at the close of his letter in NATURE of October 17 (vol. lxxvii., p. 616) makes a remark which, after some consideration, still perplexes me. The question involved is so interesting and, indeed, important, that I feel sure that many of your readers would be glad to know the grounds, doubtless not without weight, which led him to it. I quote the passage:—"that natural conditions lead to the obliteration of a host of mutations is as fair a deduction from the fact that such mutations appear under cultivation as the current deduction that the conditions of cultivation actually cause the occurrence of this kind of variation. We have the testimony of de Vries and others that the former process actually takes place. That the latter process does so is an assumption which still lacks the support of facts."

It contains two propositions:—(1) mutations appear under cultivation; (2) that the conditions of cultivation actually cause the occurrence of this kind of variation . . . is an assumption which still lacks the support of facts. It is the latter on which I think some discussion would probably be illuminating. At first sight the two propositions look contradictory. It is possible, however, that Mr. Lock is using "cause" in a very technical sense. But as Mill remarks, "in practice that particular condition is usually styled the cause, whose share in the matter is superficially the most conspicuous." Now, our knowledge of mutations is almost exclusively drawn from cultivated plants. In such cases cultural conditions are obviously an inseparable antecedent to mutations. What I do not understand is why it is an "assumption" to state that there is a causal nexus between the effect and the conditions.

To avoid ambiguity, I may explain that by "variation" I mean insensible and continuous organic change; by "mutation," that which is large, palpable, and discontinuous.

I believe that in nature variation never ceases, and yet "species" do not perceptibly vary. I pointed out some years ago, in a discussion at the Royal Society, the explanation of this seeming paradox. What we mean by a species is an abstraction which has no concrete existence. It is the mean or average of a host of varying individuals. It will be hardly contested nowadays that, so long as the conditions remain constant, the species remains unchanged. As has been frequently pointed out, the Egyptian flora furnishes a remarkable illustration of the fact over a long period of time. Plant remains from tombs believed to be 4000 years old differ in no respect from the species now living to which they belong, and the mere fact of their preservation shows that the physical conditions have undergone no change. To this persistence under constant surroundings I have given the name of "specific stability."

That mutations occur and exist is obvious to everyone. But that they are of frequent occurrence under purely natural conditions is, I think, unsupported by evidence, and, if they do occur, I agree with Darwin that it may be doubted if they "are ever permanently propagated in a state of nature" ("Origin," fifth edition, p. 46). The reason is that an organism is so nicely adjusted to its surroundings that it is in the highest degree improbable that a sudden and extreme structural change would fit in with them.

If species arise in nature by discontinuous variation or mutation, one would expect to see some evidence of their doing so; but in the British flora I can only call to mind a very few instances. There is a form of *Chelidonium majus* with lacinate leaves and petals. It is said to have first appeared at Heidelberg in 1590; according to Hooker it is only known in cultivation. There are two striking mutations of *Plantago major*, one with a paniculate inflorescence, the other with leafy bracts, which reappear

from time to time independently, but always, I think, in cultivated ground. There is a tendency in maples to revert to a ternary symmetry, as is shown by the occasional production of three carpels instead of two. The sycamore often produces seedlings with three cotyledons. I grew some of these, and they had for a time leaves in whorls of threes, but soon reverted to pairs. I have only heard of one case of an adult wild maple with leaves three in a whorl.

There are some singular mutations which occur in the broad-leaved trees of temperate countries, but probably always under somewhat artificial conditions. They seem to be merely correlated with habit, and are quite independent of affinity. The normal angles at which the branches are set on either become very acute or very obtuse; in the one case we get pyramidal forms like the Lombardy poplar, in the other weeping forms. Or the cell-sap is deeply coloured red, masking the green of the chlorophyll corpuscles (copper-beech). In other cases the leaves lose their normal circumscription, and are deeply divided (fern-leaved beech). Apparently all these mutations are in some degree perpetuated by seed, but they do not hold their own in nature, and owe their preservation to planting in gardens and elsewhere. It is not easy to speculate as to the cause of these singular mutations. One may infer from the fact that they are related to habit, and not to affinity, that they are not due to reversion.

While specific stability under constant conditions appears to be the rule in nature, it is widely different in cultivation. When a plant is brought under cultural conditions it maintains its type for some time unaltered, then gives way and becomes practically plastic. From my experience at Kew, where I saw the process continually going on, I hazarded the generalisation that any species, annually reproduced from seed, could be broken down in about five years. During that period specific stability, though menaced, tends to maintain itself. Darwin was well aware of this, and as for the moment his books seem to be little studied, I will quote the passage—

"We have good grounds for believing that the influence of changed conditions accumulates, so that no effect is produced on a species until it has been exposed during several generations to continual cultivation or domestication. Universal experience shows us that when new flowers are first introduced into our gardens they do not vary; but ultimately all, with the rarest exceptions, vary to a greater or less extent" ("Animals and Plants," ii., p. 261).

He quotes in support the testimony of well-known experts. Thus Salter, the great raiser of chrysanthemums, states:—"Everyone knows that the chief difficulty is in breaking through the original colour and form of the species." Vilmorin, the most distinguished French horticulturist of his time, maintained that "the first step is to get the plant to vary in any manner whatever; for the fixed character of the species being once broken, the desired variation will sooner or later appear."

Abundant illustrations of the fact which has been stated are furnished by the history of individual species. Thus Sabine says of the first dahlias plants introduced into Europe:—"At Madrid they were a long time in the Royal Garden without any indications of change." The history of the Zinnia and of the Swan River daisy is the same. A few years ago Mr. Watson, the curator of Kew, gave me notes of cases which had come under his own observation. *Primula japonica* was introduced in 1871 as "a new crimson primrose." In 1877 it produced rose-coloured as well as various shades of magenta flowers. *Antirrhinum scherzerianum*, introduced in 1862, had in 1874 produced enormously developed spathes, and in 1880 a form with two spathes to each spadix. In 1874 it was crossed with a white variety, and that called *rothschildianum*, with mottled spathes, was the result. It is interesting to note that "the seedlings are nearly all mottled like the parent." *Impatiens Sultani* was introduced at Kew from Zanzibar in 1881. For several years it did not vary. It now exhibits half-a-dozen distinct shades of red in the flowers. The fine Cape orchid, *Disa grandiflora*, has long been in cultivation in this country; varieties were unknown until it was raised from seed by Dr. Moore at Glasnevin.

I may add two cases which have more particularly come under my own notice. *Nemesia strumosa*, a rather local South African plant, was introduced about 1892. It now shows indications of breaking up into two distinct races, with the greatest variety in the coloration of the flowers.

The most remarkable, however, is that of *Primula obconica*, introduced in 1882. For many years it was perfectly stable, but within the last few has exhibited the most surprising variation both in the number, form, and colour of the flowers.

In all these cases I think we may safely infer from the persistent specific stability at the commencement of cultivation that the changes which subsequently occur would not have occurred in nature. We cannot regard the one state as in any way a continuation of the other. The changes which occur under cultural conditions are, in fact, something *sui generis*. We may say, of course, if we like, that the potentiality of such changes was latent in the species in nature; but, as a matter of fact, if so, it was suppressed, and there is no evidence of its being called into activity.

The evidence, on the other hand, that such changes follow cultural conditions as a result is simply overwhelming, and I do not suppose that Mr. Lock denies it to be the case. The only question can be as to how they operate. Now there is one point in connection with plants under cultivation the importance of which I have not seen referred to. It is this: in nature we deal with a host of individuals; in cultivation with a very limited number. In my view specific stability is maintained partly by the weeding out of unfavourable variations, partly by wide interbreeding. Now it is obvious that under cultivation the latter agency is inoperative, and cultural conditions bring other influences to bear, especially as regards nutrition; but these I have no space to discuss.

I take it that the species in nature has two weapons in reserve for self-preservation. Of these, variation is the most effective if given time, as it will act automatically. Mutation, on the other hand, though it might now and again hit the mark, is likely in most cases to overshoot it, and is therefore seldom called into play or utilised; and observation seems to confirm this.

In the development of a plant under cultivation the horticulturist takes advantage of both variation and mutation. In the case of the Cyclamen, I have shown that the fine forms now existing are almost entirely the result of accumulated variation. As with the garden Cineraria there has been mutation in floral coloration; but the small amount of variation in the foliage proves, I think conclusively, that in other respects the latter has gradually been evolved from the wild *Cineraria cruenta*, though Darwin, from second-hand information with which I supplied him, stated otherwise.

The case of the Chinese primrose is extremely interesting. When introduced in 1820 it had probably already undergone some cultural development at the hands of the Chinese. It was slowly developed in Europe for a long period without manifesting any striking structural change, until it bore little superficial resemblance to the wild stock. This was discovered in the gorge of the Yangtze, and when introduced into this country proved very intractable of cultivation; in fact, I doubt if at the moment it is to be found in our gardens. Within about the last quarter of a century the cultivated form has exhibited two very remarkable mutations, and it is interesting to observe that these appear to recur independently. The first was the so-called "fern-leaved form." I do not know if this was ever fixed, but, if so, it did not take the public taste, and was not preserved; but fern-leaved individuals appear to occur casually in batches of seedlings of quite distinct races with the ordinary foliage. The transition from the palmatifid to the pinnatifid form of leaf is theoretically interesting. Nothing can well look more different than a fan-palm and a feather-palm, but we can see an intermediate stage in an Australian Livistona. The second mutation, the "ivy-leaved form," is much rarer, and in every way more remarkable. It is apparently accompanied by more or less floral abortion, and it has not been found

possible to perpetuate it. The fern-leaved form is, it can hardly be doubted, a reversion to an ancestral type which has been perpetuated in other species, and this may also be the case with the ivy-leaved form, though this is more obscure.

The races of *Cenothera* which De Vries has raised are nothing more than what a horticulturist would expect; and it may be conceded that if such races could hold their own in nature, distinct species might originate in this way. But there is no evidence that they do; and the probability of their being able to do so is against them. *Cenotheras* are pretty prolific where they occur, and so far as my experience goes they keep true to type.

Cultural mutations seem, as a matter of fact, to have little, if any, capacity for holding their own in the struggle for existence. I cannot call to mind a single instance of one which has been successful, and even in cultivation there is some reason to think that they are short-lived; but this is a point on which we are in urgent need of carefully ascertained facts. One is told, for example, that new varieties of the potato mostly cease to give satisfactory results after a few years. This is, however, a case of purely vegetative reproduction, and similar statements are made about the sugar-cane, which it is now hoped to regenerate by seminal reproduction. I can remember when potato-fields were covered with flowers and subsequently with fruit. I suppose it was thought antagonistic to tuber-production, as it probably was, and sterile races were selected accordingly. Prof. Hildebrand came to this country to study the subject, and I was able to supply him with information which I had collected for another purpose.

There is practically nothing to add to what has been said on the subject by Asa Gray ("Darwiniana," pp. 338-347). It is notoriously difficult to get hold of old cultivated strains of garden plants, and change of fashion hardly seems sufficient to account for the difficulty. Gray points out "that with high feeding and artificial appliances comes a vastly increased liability to disease, which may practically annihilate the race." This has all but happened to the hollyhock, and, left to itself, the *Phylloxera* would have exterminated the vine in Europe. The existence of a species in nature implies a complicated adjustment to the surroundings. It is not sufficient to launch upon them a new form; in order that it may hold its own, the adjustment must be provided as well. It is by no means always an easy thing to transfer a species from one part of the earth's surface to another. The seed of the Kerguelen cabbage brought back by the *Challenger* germinated freely at Kew, but not a single plant was raised from the seedlings, which all succumbed to a ubiquitous *Peronospora*.

De Vries has done good service in directing attention to the study of mutations, the nature and origin of which deserve the most attentive study. They graduate into monstrosities which are even more mysterious. It is worth while directing the attention of those who are interested in mutations to the material which exists in Japanese horticultural books. Japanese taste in such matters is widely different from European. In the case of the garden convolvulus (*Ipomoea*), which is pretty stable with us, the Japanese have figured an extraordinary range of variations which no one else would dream of preserving.

W. T. THISELTON-DYER.

Witcombe, November 9.

The Winding of Rivers in Plains.

BEFORE writing to NATURE on the theory of winding rivers, it would have been wiser for me to have had some observations made as to the conditions of actual flow in the field in different circumstances. It is possible that the more complicated conditions which obtain in some places render the simple theory only partially applicable. My letter was immediately applicable rather to the flow in Prof. James Thomson's simplified model, where the artificial stream had a wooden bed, and the tendency to silt was indicated by short pieces of cotton pinned by one end to the bottom. It may be that the deposit of drift

on the inner side of some streams retards their flow by an unexpected amount; and probably there are other causes which prevent the James Thomson theory from being the last word on the subject. I do not pretend to be a field naturalist in any sense, and my cautionary note concerning the flow of glaciers I would ask readers to apply to the flow of rivers also, and to interpret the whole of my letter as a hint and exposition of theory rather than as an assertion and statement of fact.

OLIVER LODGE.

November 20.

SIR OLIVER LODGE's letter in NATURE of November 7 on the winding of rivers in plains has induced me to measure the velocity of flow in different parts of a bend in the river Wey near here. A short line—17 feet—was measured on the bank at the bend, and marks set up at right angles to it, and the time taken by blocks of wood to move between the marks measured with a stop-watch. The distances of the blocks from the inner bank were estimated in terms of the breadth of the river, with the following results:—

Distance from inner bank	Velocity in feet per second
0·3	0·30
0·5	0·45
0·6	0·55
0·8	0·71

This does not bear out his statement that "the flow is most rapid on the inner or sediment-depositing side of the bend," and that the water near the concave bank is nearly stationary, but upholds the common opinion of boating men and others.

The numbers refer to the surface flow only, and it is quite probable that there may be the undercurrent across the bed of the river; in fact, the sudden shelving so often noticed in rivers, and harbour channels where there is a strong tide, has led me to suspect for a long time such cross-currents.

The surface flow-lines are neither parallel nor straight. For this reason a short base line was used, and the velocities obtained are only approximate, but are certainly not far from the above values.

At the end of the experiments two blocks of wood were simultaneously floated down the stream, one near the inner, the other near the outer bank, and the latter won the race by twelve seconds.

However, I noticed that close to the outer bank (within 2 or 3 feet of it) there were back eddies forming a set of feeble whirlpools, and these may play an important part in the scouring.

R. C. SLATER.

Charterhouse, Godalming, November 17.

The Occurrence of Copper and Lithium in Radium-bearing Minerals.

It is possible that the remarkable action of radium emanation on copper, as recently announced by Sir William Ramsay (NATURE, July 18, vol. lxxvi, p. 269), may not be confined to solutions, but may also occur in the solid state. If so, it should be found that those minerals which contain both radium and copper contain lithium also.

In connection with another investigation, I had separated a sample of pitchblende, from Gilpin County, Colorado, into its principal constituents. The amount of copper in the sample was considerable. The final filtrate, remaining after the separation of the various analytical groups, contained only ammonium and alkali salts. After the evaporation of a portion of this solution, representing about 3 grams of the mineral, and the volatilisation of the ammonium salts, a small residue was left which, when examined spectroscopically, gave a very bright lithium line. This result led me to examine four other samples of uranium-radium minerals. These samples com-

prised a second specimen of pitchblende from the same locality as the first; carnotite from Montrose County, Colorado; gummite from North Carolina; and pitchblende from Bohemia. All the minerals, with the exception of the gummite, contained both copper and lithium in easily recognisable amounts. The qualitative analysis of 1 gram of the gummite showed no copper, but did show the presence of lithium in small amount.

The discovery of lithium and copper in uranium-radium minerals does not necessarily indicate the change of copper into lithium, since the presence of lithium may have been fortuitous; but assuming the accuracy of Prof. Ramsay's observation, the presence of lithium in uranium-radium-copper minerals is precisely what one should expect. The presence of lithium and absence of copper in the sample of gummite may be explained by the assumption that the change of copper into lithium has been completed. It may be added that even if further investigation should reveal the absence of lithium in any uranium-radium-copper mineral, the result would not constitute a valid argument against Prof. Ramsay's hypothesis, since the latter referred to copper in solution and not in the solid state.

HERBERT N. MCCOY.

University of Chicago, November 6.

A Convenient Formula in Thermodynamics.

It is possible that many teachers of thermodynamics may not have noticed that the characteristic equation for 1 kilogram of air takes the easily rememberable form $p = T/10$, when p is measured in standard atmospheres, v in cubic feet, and T in thermodynamic centigrade degrees, the accuracy of the even integer being fully as great as that of the gas law itself. These units are, of course, a curious mixture of the English and Continental systems, but this seldom makes much difference in actual problems, and the convenience of the formula for rough mental computations is sometimes very great.

The data upon which this computation of the gas constant is based are the statements in the third (1905) edition of Landolt and Boernstein, that 1 litre of air under standard conditions weighs 1.2928 grams, and that an English yard is 0.91438 metre, and the value $T_0 = 273^{\circ}.13$ given by Buckingham in the Bulletin of the Bureau of Standards for May. The value $R = 0.1$ is consistent with these assumptions within less than one-fiftieth of 1 per cent.

The corresponding values of C_p and C_v , reduced from the mean of the results of Regnault (1862), Wiedemann (1876), and Witkowski (1896), are $C_p = 0.3467$ and $C_v = 0.2467$ cubic-foot-atmospheres.

Cambridge, Mass.

HARVEY N. DAVIS.

A Miocene Wasp.

IN NATURE of June 13, 1901 (vol. lxiv, p. 158), I described a curious variation in a bee (*Epocelus*), the second transverso-cubital nerve of the wings having its lower half absent. This aberration was evidently an example of "discontinuous variation," and from its occurrence in several specimens captured at the same place, it seemed that it must be inherited. There is a genus of Scoliid wasps, *Paratiphia*, in which the absence of the lower part of the first transverso-cubital nerve is normal. The species, found principally in the southern and western parts of North America, are quite numerous; and the broken nerve, looking exactly like the aberration described in the bee, is a good generic character. Nothing has hitherto been recorded concerning the past history of this genus, but I have before me a well-preserved *Paratiphia* from the Miocene shales of Florissant, Colorado, collected by Mr. S. A. Rohwer at station 14 in 1907. This insect, which I shall call *Paratiphia praefracta*, is black, with the thorax large and robust (about 4 mm. long and 3 mm. broad); the head rather small (slightly more than 2 mm. diameter); the antennae thickened; the abdomen constricted between the first and second segments, and parallel sided beyond; the hind

tibiae dentate on the outer side; the wings clear hyaline, anterior wing about 7 mm. long, with the large stigma very dark, the nervures light ferruginous. The specimen is a male. The venation is perfectly normal for *Paratiphia* in every respect, including the broken transverso-cubital vein.

It is certainly an interesting fact that a character like that of an imperfect vein, which can arise suddenly as a mere aberration, should persist from Miocene times (at least) to the present, and characterise a whole genus. From observations on bees and other Hymenoptera, it is evident that this modification has occurred many thousands of times without becoming permanent; that it has become so in the case of *Paratiphia* is therefore all the more remarkable.

T. D. A. COCKERELL.

University of Colorado, Boulder, Colorado,

November 7.

The Eggs of the Platypus.

SINCE writing the notice of Mr. le Souef's book on Australian wild life in NATURE for October 24 (vol. lxxvi, p. 635), I have been making inquiries as to the existence in collections of any examples of platypus egg definitely known to have been taken from the nest after extrusion. It has been suggested to me that Mr. Caldwell and Dr. Semon might possess such specimens. The former gentleman told me, however, some years ago that he never found an extruded specimen, and I learn from Dr. Semon that he was equally unsuccessful in this respect. In his letter he writes that "I have never found extruded eggs of *Ornithorhynchus*, but only intra-uterine specimens. To obtain the former, it would be necessary to open a very large number of burrows."

In the central hall of the British Museum is shown an egg-shell of a platypus sent from Queensland by Mr. G. P. Hill in 1902, but this, like Mr. le Souef's specimens, was doubtless found in its present broken condition.

Such broken shells might, apparently, be extruded from the uterus with the fetus; and, so far as I can find, there still appears to be no definite evidence that the eggs are really laid entire.

THE REVIEWER.

November 15.

Literature relating to Australian Aborigines.

IN NATURE of May 6 (vol. lxxvi, p. 32) I observed a communication from Mr. R. H. Mathews in which he makes certain statements imputing to me, by insinuation, what amounts to literary dishonesty. Will you kindly permit me to express my views on the subject?

Mr. Mathews says that I have "ignored" certain statements made by him in communications to scientific societies, and which were published before the appearance of my "Native Tribes of South-East Australia" in 1904, in which I record the same facts.

Mr. Mathews speaks of my account of the Dora ceremony, and makes the following insinuation:—"Dr. Howitt 'ignores' that I described that rite in January, 1900. If he did not avail himself of my work, which appeared four years earlier than his, then there is a wondrous agreement in our details."

My account of the Dora ceremony was given to me by Mr. Harry E. Aldridge in 1882. It was from his own experiences at the ceremonies on more than one occasion, and he had a knowledge of the tribal language.

Mr. Mathews also says that I "ignore" a map which he published in 1900, and which is substantially the same as one at p. 44 of my work. He adds the following sentence:—"In comparing the two maps and the explanatory letterpress accompanying mine, we observe a marvellous coincidence. Many other examples could be cited."

The map showing the native tribes of South Australia at p. 44 of my work was compiled from data supplied by the Rev. Otto Siebert, who obtained them by careful and protracted inquiries from persons knowing the several localities, as well as from personal knowledge. Practically

the details as to the tribes of the Lake Eyre district and of the Flinders Range are substantially the same as those given in a sketch-map which accompanied one of my pioneer papers entitled "The Dieri and other Kindred Tribes of Central Australia," which appeared in the *Journal of the Anthropological Institute* of August, 1890. This was the result of investigations made from 1871 to that date. In this instance, if I were to follow Mr. Mathews's example, I might suggest that he has "ignored" this pioneer work, and express something similar to his "wondrous agreement in our details." There is, however, nothing to wonder at in the agreement of two investigations of the same subject. My statements are based upon independent investigations, made in some cases many years ago, when the results were recorded for future publications. If Mr. Mathews finds instances in which his information has a "wondrous" agreement with mine, he may rest assured that his conclusions are correct.

My information as to the Yantruwunta class-names *Tiniwa* and *Kulpuru* was received from my correspondent the Rev. Otto Siebert, and was based on his personal knowledge, in 1897.

I learn from Mr. Mathews's letter that he has sent "more than one hundred contributions to various scientific societies." I have only met with two of them, neither of which recommended itself to me by its accuracy. It is therefore difficult to understand how I can have "ignored" statements of which I am ignorant.

It will be evident that there is no foundation for Mr. Mathews's injurious insinuations, which, I regret to say, bear upon them evidence of a personal animus. The case is one of *Honi soit qui mal y pense*.

A. W. HOWITT.

Metung, Victoria, July 8.

In the foregoing remarks Dr. A. W. Howitt states that at the time his book appeared, in 1904, he was not aware that I had published a description of the *Toara* (*Dora*) ceremony, and also a map of South Australia, four years previously. It seems incredible that he did not make himself acquainted with the current literature bearing upon the Australian aborigines up to the time he published his book.

If Mr. Howitt obtained his account of the *Dora* from Mr. Aldridge in 1882, it is remarkable that he did not publish it until twenty-two years afterwards, especially as he was very prompt in publishing his report of the *Kuringal* ceremony in 1884 and the *Jeraeil* in 1885. He does not, however, appear to have had much confidence in Mr. Aldridge's account of the laws of marriage and descent in vogue among the same tribes who practised the *Dora* ceremony. He says that Mr. Aldridge sent him "a number of tables of marriages and descents, which differed considerably amongst themselves; so much so that the correctness of some of them seemed doubtful."¹ Mr. Howitt did not run the risk of printing more than one table out of them all, but even that one is erroneous, as I have demonstrated elsewhere.

Mr. Howitt refers to a "sketch-map" published by him in 1890.² In that map he showed the *Urapuna* (my *Arrabunna*) tribe as being located away to the north of the *Awmani* (my *Ahminnie*). Not content with this inaccuracy, he increased its magnitude by placing another tribe, which he called the *Wongkurapuna*, on the east of the *Urapuna* and *Awmani*. He was, apparently, not at that time aware that the two names, *Urapuna* and *Wongkurapuna*, represent the same people, the prefix *wongk* merely meaning "speech."

Again, the *Kuyani* (my *Kooyeunna*), which I place on the southern end of Lake Eyre, is shown on Mr. Howitt's "sketch-map" as occupying the country I have correctly allocated to the *Kutchnamootha* tribe. His map is altogether a blank as to the numerous tribes occupying the country from south Lake Eyre to Port Lincoln and Fowler's Bay. Even Mr. Howitt himself did not reproduce his own map in his book of 1904, but preferred to

utilise one which is identical with mine. Spencer and Gillen were apparently misled by the worthless map of 1890. In referring to the *Urabunna* tribe, they speak of "the Dieri, whose territory adjoins the *Urabunna* on the south."³ My map shows the *Urabunna* on the western or opposite side of Lake Eyre to that on which the *Dieri* is situated.

Mr. Howitt states that he got the phratry names *Tiniwa* and *Kulpuru* independently. Even if so, he should have made himself acquainted with and referred to my prior reports of 1899 and 1900. He shirks my statement that he "had never heard of the Blood divisions," and he also passes over my claim to priority in reporting certain important facts in the sociology of the *Wiradjuri* tribes.

It is asserted by Mr. Howitt that he has only seen two of my articles on the Australian blacks. I contributed five articles to the *Royal Society of Victoria*, of which Mr. Howitt was a member, and I was told that he took part in the discussions upon some of them. They were all printed in the *Proceedings* of that society, vols. vii., ix., and x., and these volumes were issued to Mr. Howitt in virtue of his membership.

Numerous articles of mine have been published by the anthropological societies of the following places:—London, Berlin, Washington, Paris, and Vienna, as well as by other societies. I presented forty separate copies (reprints) of various papers written by me on the aborigines to the public library in Melbourne in 1899. A bibliography of nearly all the articles published by me is printed in the *Journal of the Royal Society of New South Wales*, vol. xxxviii., pp. 376-381. The whole of my works are therefore within reach of any man who wishes to consult them.

As I am about to make a strong assertion, I will confine myself to five articles published in the *Proceedings* of the *Royal Society of Victoria* and twelve in the *Journal of the Anthropological Institute*. If Mr. Howitt still maintains that he has not seen these seventeen articles, I cannot believe him.

In regard to Mr. Howitt's remark that where I find "instances" in which my information agrees with his I may rest assured that my "conclusions are correct," I may briefly mention that on one occasion, in 1894, I did rely on Mr. Howitt's assertion that descent in the *Kaibara* tribe is in the male line. From personal inquiries among the blacks in 1898 I was able to correct my former statement, and to show that descent is in the female line.⁴ Mr. Howitt, however, repeats his former error in his book at p. 229, where he says that "descent [in the *Kaibara*] is in the male line."

Mr. Howitt accuses me of "personal animus." There cannot be any question about the "personal animus" which prompted him to ignore my prior work, which had the effect of temporarily misleading an English reviewer. Nor can there be any mistake about the animus evinced in the statement that he has "only met with two of my papers, neither of which recommended itself to him by its accuracy." His object in both cases is manifestly to make little of my work. Even now, while he tells us that he ignored my prior work in "ignorance," he does not express any regret, but attempts to justify the course he adopted.

In the present case both authors reside in the same country and are known to each other as workers among the same tribes. I cannot help repeating that it is both "marvellous" and "wondrous" if they did not make themselves acquainted with each other's publications, especially as there were intervals of four, five, and eight years in which to do so. Mr. Howitt's experiences should be a warning to others to avoid the pitfall of claiming originality for work which has already been published some years in scientific journals of undoubted repute.

R. H. MATHEWS.

Parramatta, New South Wales.

[No further correspondence can be published on this subject.—ED. NATURE.]

¹ "Native Tribes of S.-E. Australia," p. 231.

² *Journ. Anthropol. Inst.*, xx., p. 30.

³ "Native Tribes of Central Australia," p. 59.

⁴ *Proc. Amer. Philos. Soc.*, Phila., xxxvii., p. 335; with map.

NOTES ON ANCIENT BRITISH MONUMENTS.¹

II.—The Cornish Cromlechs.

FROM the point of view of orientation, the interest in barrows, tumuli, chambered cairns, dolmens and cromlechs lies in the assumption that they were built for live men to dwell in. That they all represent different stages of the same structure—stages depending upon decay due to the action of rain, or wanton destruction in the interests of agriculture—can be gathered from a complete study of the whole evidence.

Borlase, in his "Dolmens of Ireland" (p. 426), refers to some of it. Mr. John Bell, of Dundalk, a famous antiquary, disinterred no less than sixty cromlechs from cairns or barrows in Ulster. Many "cairns," indeed, on the early Ordnance maps are marked dolmens in subsequent editions, the interior stone framework being the only thing remaining after the covering of soil had been re-distributed over the fields, an ordinary "agricultural" operation.

Borlase insists upon the fact that large tumuli were not essential; "all that was necessary was that the walls of the cell or crypt should be impervious to the elements and to wild animals" (p. 427). As a corollary to this, "in distinction from the cist, it was the intention and object of the builders that access should be had to it [the cell or crypt] from within."

It was this intention which has provided us with "creeps," "fougous," "allées ouvertes," and "allées couvertes," and these, as I shall show, are of as high importance as the cell itself from the orientation point of view. They all constituted, not only entrances, but "outlooks" for the man inside; and it matters not whether the cell was as extensive, as complicated, as carefully built, and the creep as long, as at Maeshowe, or whether we deal with a cell of the simplest and rudest form, with a bare entrance and outlook, such as the crecphole in one of the stones at Treveithy.

Archæologists, as a rule, though not, I think, universally, consider the whole series of structures we are now dealing with as having originally, whatever their present stage, been constructed for tombs.

For them there is little difference between such a cell with an entrance such as the barrows and cromlechs reveal; and a cist, which is simply a rude small coffin built up of five or six stones, in which there is only room for the body, and to which there is no entrance at all. The evidence on which they rely is that certain things have been found in these cells, which they consider can only have been associated with burials.

¹ Continued from p. 59.

The argument against this view does not only depend upon the details of structure, such as revealed in Maeshowe, perhaps the most perfect cell now remaining, but upon their association with other stone monuments, especially with stone circles; so that as the Gorsedd we see to-day is but a survival of the ancient stone circle which was associated with living men, the cromlechs must, in all probability, have been also associated with living men. They are not merely tombs. I hold that they were never meant for tombs, and to argue that they were built for sepulchral purposes because people have since been buried in them is to deny that a church was built for the worship of God because we find corpses in it.

If we consider frankly and fairly the position of the first priests and leaders of the people who controlled the worship and the daily life of the early inhabitants of Britain, we can arrive at a quite plausible theory concerning these cromlechs.

The circle builders had to look after the welfare of the surrounding population, and see what they could do to help them in every way; and when we consider

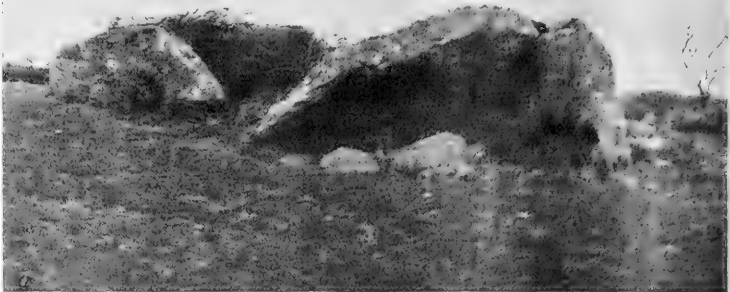

Photo. by Lady Lockyer.

Fig. 7.—Cromlech on Lesquic Farm, near Eodmin. The upright stone on the right is oriented to the May sunrise.

that, I think much of the mystery surrounding the cromlech is at once cleared away. In the first place, there is no doubt in my mind that these people, who had command of the sea, and came over here and built the circles and cromlechs along our shores, and cared very little for going inland where they could not be supported by their constantly returning ships, were Semitic in their origin, or familiar with the Semitic peoples. In any case they must have lived somewhere, and with some kind of shelter.

Now we know from Robertson Smith that Semitic worship was carried on in caves, and one reason for this might have been that the priests really lived in caves.

Now the cromlech was really an improvement upon the natural or artificial cave, and, further, if there were no caves, some shelter must have been provided. The easiest way to protect the priests and priestcraft from the elements and from animals was by erecting such a structure as stones would enable them to do,

and then covering it with earth which could not fall upon them, and I look upon the stones of the cromlech as the skeletons of the barrows which were thus built to protect the people living in them.

One of the first things that they wanted to be pro-

They must have required food as well as drink, and they must have cooked their food, or have eaten it raw; the evidence of bones and ashes shows that they cooked it. Considerations of this kind suggest that many of the things, including structure and contents,

that archaeologists have associated with death may as reasonably and probably have been associated with the life conditions possible to the early inhabitants of our islands.

The above-stated view that men really lived in the cromlechs, which we know to have been associated geographically with the circles, would be strengthened if we could show that the construction of the cromlechs was such that they were associated with circles in other ways, and in such ways as would require the presence of the same men in both.

I have recently commenced the study of the cromlechs from this point of view, using the orientation theory as my guide. The work at the circles has shown conclusively—to my mind at all events—that they were used, among other things, as calendars or almanacks, to watch the sun's course throughout the year and so locate the various festivals which are all older than Christianity; and as

night-dials to determine the lapse of time during the night and the rising of the morning star, so that the morning fire-sacrifice could be made at the moment of sunrise.

tected from was damp. It was important to keep out the rain, because they had their fires to look after, not merely for cooking purposes, but for sacred purposes, and if they did not keep their sacred fires going, as Mr. Baring-Gould believes they did, they must have been, at all events, sure of a supply of dry wood. That is one reason why they should try to keep out the damp. Britain was then much richer in wild animals than it is now, and measures had to be taken to protect the priests, both in the day and during the night, from the incursions of animals by keeping them out in some way or other. I think this is a point which archaeologists have not sufficiently considered. There were no carpenters in those days. They could not cut down a tree. They could not make a door. When we consider the matter carefully, we find that the only way to protect themselves was by constructing, however large the chamber, an entrance to it which should be very small, because it must have been closed by a small stone, capable of being handled by one or two men, the only way they had of sealing it.

Then these people had to drink, and it was only natural that they should have a water supply in these cromlechs. May that not be the real origin of all the crockery, large or small, and the horn spoons, that one finds in these places?



Photo. by Lady Lockyer.

FIG. 8.—Druid's Altar at Pawton, near Fodmin, looking to May sunrise.



Photo. by Lady Lockyer.

FIG. 9.—Druid's Altar, looking towards November sunset.

Now all this would require a staff, and both the staff and the fire would require some shelter. I have assumed the cromlech to be this shelter, and this assumption enables us to go a step further. A convenient arrangement would be that much or most of

the watching during the night—it was all night work if in the term night we include the dawn—could be done in the shelter itself, and this could be managed if the entrance to it was aligned on the part of the horizon to be chiefly watched.

Now what were those points? The circles supply the information. They were chiefly, as the May-year was then paramount, the sunrise place in May and August, when the sun's declination is $16^{\circ} 20' N.$, and that in November and February, when the sun's declination is $16^{\circ} 20' S.$, these two sunrise places marking off the quarters of the year and the chief festivals. Next came the rising place of the clock-star, and later the place of sunrise on the longest and shortest days—the solstices.

The question to be settled, then, is, Do the entrances to the cromlechs point in these directions? Could the priests have done their night work under shelter?

Some of the data used in the attempt to answer this question I have obtained myself from the monuments; in other cases I have endeavoured to get the required information from the so-called plans or surveys to be found in archaeological records. The great majority of these, however, I have found to be utterly useless for my purpose. A brilliant exception, however, is found in the carefully oriented work of Lukis on the Cornish monuments, so I will begin with Cornwall and the May-year sunrises.

The following table gives the theoretical values of the azimuths of the sunrise places. It has been previously shown in my book, "Stonehenge," that the circles conform to them.

Cornwall. Lat. 50° .

Conditions	True Azimuths	
	May and August sunrise	November and February sunrise
Sea horizon, refraction, semi-diameter	N. $62^{\circ} 58' E.$	S. $64^{\circ} 32' E.$
$\frac{1}{2}^{\circ}$ hill	N. $63^{\circ} 44' E.$	S. $64^{\circ} 22' E.$
1° "	N. $64^{\circ} 30' E.$	S. $63^{\circ} 34' E.$
$1\frac{1}{2}^{\circ}$ "	N. $65^{\circ} 16' E.$	S. $62^{\circ} 50' E.$
2° "	N. 66°	E. S. $62^{\circ} 5' E.$

Following this table I give another, showing the azimuths of most of the chief Cornish cromlechs.

Orientation of Cornish Cromlechs.

Name	Remarks	Azimuths (true)
SERIES I		
Lesquoit Farm	My own observations, April, 1907, near Bodmin. Hill, 13°	N. $64^{\circ} E.$
Druid's Altar ...	My own observations, April, 1907, at Pawton. Hill, 13°	N. $64^{\circ} E.$
Lanyon Quoit...	This was "re-erected" before Lukis's time, so I have taken Borlase ("Antiquities of Cornwall," plate xxi), assuming his N. is N. true ...	N. $66^{\circ} E.$
Mulfra Quoit ...	Lukis, plate xix ...	N. $63^{\circ} E.$
Chywoone Quoit ...	" " xx ...	N. $64^{\circ} E.$
Zennor Quoit ...	" " xxi ...	N. $64^{\circ} E.$
Three Brothers of Grugith ...	" " xxiii ...	N. $64^{\circ} E.$
SERIES 2		
Trewethy ...	My own observations, April, 1907, near St. Cleer ...	S. $62^{\circ} E.$
Caerwynen ...	Lukis, plate xxiv ...	S. $65^{\circ} E.$
Pennance ...	" " xxix ...	S. $64^{\circ} E.$

We see, then, that many of the chief Cornish cromlechs are aligned on the May and August or the November and February sunrises as carefully as are the outstanding stones connected with the associated circles.

The true azimuths have been determined from magnetic observations made by Lukis and myself by subtracting $20^{\circ} 30'$, the west variation in Lukis's time, and 18° at the present in the case of my own observations; it will be seen that they agree closely with the theoretical values given above.

The above list, however, does not exhaust all the cromlechs in Lukis's work perfect enough to allow of their orientation to be determined. We have:—

Name	Remarks	Azimuths (true)
Tregiffan ...	Lukis, plate xv ...	N. $52^{\circ} E.$
Barrow near Tregaseal circles ...	Lukis, plate xvii, reproducing Trounson ...	S. $50^{\circ} E.$

These are solstitial alignments. The variation of 1° or 2° in this and the preceding table no doubt arises from the fact that the height of the horizon varies from place to place, and no information on this head is given by Lukis.

NORMAN LOCKYER.

THE PRESERVATION OF EGGS.

FEW people not directly connected with the trade have any adequate idea of the extent to which the egg of the domestic fowl is imported into this country. Whether the volume of this trade ought to be an unmixed source of satisfaction to us is another question, for there can be little doubt that if some of the energy, enterprise, and organising power which have been turned to such excellent account in Denmark, for example, were applied to the production of eggs in this country, we should be less dependent than we are on foreign supplies. Intimately bound up with this question of egg production is that of their preservation, but although much has been written on the value of particular methods, no systematic investigation of the conditions under which eggs must be kept to maintain and ensure their quality as food has hitherto been attempted, nor has any proper comparison been made as to the relative merits of the various methods which are practised. Those who are interested in this important subject will therefore welcome the appearance of a paper by Mr. Fr. Prall in a recent number of the *Zeitschrift für Untersuchung der Nahrungs- und Genussmittel* (No. 7, vol. xiv., October 1, 1907, p. 445), in which the question is treated both observationally and experimentally with all the precision and care which should characterise a scientific inquiry.

The adequate solution of this problem demands that the eggs when preserved shall maintain their normal appearance, smell and taste; in other words, they must in nowise differ in chemical and physical characters, or in behaviour on cooking, from fresh eggs. The chemical and physical changes to which eggs are naturally subject are largely dependent on the temperature and relative humidity of the air, and on the presence in it of moulds and germs. In an absolutely sterile atmosphere at a sufficiently low temperature and of a proper degree of humidity, eggs will preserve their "freshness" for very long periods of time, if not indefinitely; and all successful methods of keeping eggs imply a practical recognition of these conditions.

Of the various methods of distinguishing old and

bad eggs from fresh eggs, one of the simplest is to make a hole of about the size and shape of an egg in a wooden or tin box, and hold the egg in the inside of this box against the light behind the hole. Good sound eggs are thus seen to be perfectly transparent without striations or spots, and the bubble of air within is not wider in diameter than a sixpence.

Eggs selected for preserving should be those of well-fed fowls—preferably from those of which corn is the chief diet. The eggs should be quite clean; if dirty they should be washed with a little dilute alcohol (50 per cent.), and carefully dried.

In what may be called "dry conservation," the main thing is to keep the surrounding air as clean as possible, and free from smell. The temperature should be low, but should not sink much below 32° F., otherwise freezing might cause the eggs to burst. The relative humidity should be from 60 to 80. The best plan is to stand the eggs on an egg-rack in a cool, light cellar, and preferably in an ice closet, or, on the large scale, in cold-air stores, with their points downwards, so that the air can circulate freely round them. Nothing is gained by turning the eggs at short intervals, say weekly, as recommended by some; or by packing them in salt, sawdust, powdered coal, or charcoal, wood ashes, sand, &c. Some of these things are found to "taint" the eggs; others are apt to become damp and set up the action of moulds.

It is occasionally recommended that the egg should be protected from the outer air by covering the shells with fat, vaseline, paraffin wax, collodion, &c., or that the shell should be treated with salicylic, boracic, or hydrofluosilicic acid, or even sulphuric acid, whereby the calcareous material is chemically altered and made less pervious. Immersing the egg in Condy's fluid or a solution of potassium permanganate has also been suggested. Eggs so treated in no case were found to keep better than by cold storage in pure air.

Eggs which cannot be kept in cold stores or in an ice-chest may be preserved by Hanika's method. This consists in first putting the clean eggs into recently-boiled water at a temperature of about 110°, and then dipping them into boiling water for 10 seconds, after which they are to be immediately put into cold water. By this treatment all organisms are killed, and a hard coating is formed between the shell and the "white." The shells are finally washed with a little strong alcohol, dried, and placed in clean, dry sawdust. Eggs so treated were found to be in perfect condition after the lapse of nine months.

Attempts are frequently made to preserve eggs by immersing them in solutions of various salts, or of substances which are known to act as antiseptics. Few of these solutions give a wholly satisfactory result; indeed, many of them, as, for example, salt, salicylic acid, borax, and glycerin, penetrate the shell, and either harden the yolk or impair the flavour. Of these liquids lime-water has been most frequently used, but by long immersion in this solution the yolk is apt to mix with the white, and the shell is rendered so fragile that it is very liable to be broken on boiling. The white of an egg which has been kept in lime-water is difficult to "whip." Much better results are obtained by the use of a 10 per cent. solution of water-glass, especially if the shells are smeared with fat or vaseline, whereby the slight taste of the alkali which the eggs are otherwise apt to acquire may be obviated.

Mr. Prall's paper, which contains the results of many hundreds of experiments and carefully made observations, arranged in tabular form and set out in detail, is a valuable contribution to the economics of an important food problem, and merits careful study by those who are interested in the subject.

NOTES.

On Thursday last, November 21, the Lord Mayor of Liverpool presided over an influential gathering of Welshmen from that city and from the Principality, and the following resolution was carried unanimously:—"That this meeting believes that the time has come for the early history of Wales to receive full and systematic investigation by all the means at the disposal of modern archaeological science." The Oxford professor of Celtic (Sir John Rhys) supported this at some length, pointing out that sporadic excavations were not enough in themselves, and that a systematic survey should also be made of all the antiquities of Wales and the Marches. This would entail, not only the digging over of barrows and graves, but the orientation of stone circles, cromlechs, and camps. The theodolite as well as the shovel should be called into requisition; in fact, no means should be neglected which might tend to increase the value of the investigation. Two other motions were passed, and a committee, which includes Dr. Arthur J. Evans and Prof. Haverfield among its members, was appointed for the carrying out of the work. The weight of the undertaking will fall on the University of Liverpool, which, however, is to receive assistance from the Welsh colleges. Our readers need not be reminded that Liverpool University lays special stress on the study of archaeology, and includes among its staff Prof. Bosanquet and Prof. John Garstang. We have every confidence that any work undertaken by Liverpool will be done well and thoroughly. The organising secretary is Mr. Owen Rhoscomyl, 38 Bedford Street, Liverpool.

The Wilde medal for 1908 of the Manchester Literary and Philosophical Society has been awarded to Prof. J. Larmor, F.R.S., and will be presented to him on March 3 next. Prof. Larmor will on that date deliver the Wilde lecture on "The Physical Aspect of the Atomic Theory," and will be entertained afterwards at a dinner in his honour.

The Physical Society announces that the third annual exhibition of electrical, optical, and other physical apparatus will be held at the Royal College of Science, South Kensington, on Friday evening, December 13, from seven to ten o'clock.

The executive committee of the National Physical Laboratory has appointed Mr. G. W. Walker, official assistant to the professor of natural philosophy in the University of Glasgow, as superintendent of the Eskdalemuir Observatory. Mr. Guy Barr, of Christ's College, Cambridge, has been appointed to an assistantship in the metallurgical and chemical department of the National Physical Laboratory.

The death is announced, at the age of sixty-nine, of Prof. T. Barker, professor of mathematics at Owens College, Manchester, from 1865 to 1885.

An international exhibition of applications of electricity will be opened at Marseilles on April 19, 1908, under the patronage of the Government of the French Republic, and with the cooperation of the local authorities, municipal council, general council, Board of Trade, and other bodies. Particulars can be obtained at the office of the Commissariat-General, Boulevard Louis Salvator, 52, Marseilles, and at the Secretariat-General, 63 Boulevard Haussmann, Paris.

The *Times* correspondent at Cape Town reports on November 23 that the Chief Justice, presiding at a meeting of the National Preservation Society, urged the need of stronger measures to preserve rare flora and fauna from

extinction. The gnu, gemsbok, mountain zebra, eland, and giraffe were all nearly extinct. He said he remembered, when a barrister on circuit, seeing great herds where there are now railway stations.

At a meeting of the Royal Society of Edinburgh, held on November 4, the following were elected honorary fellows:—(1) as *British Honorary Fellows*, Sir A. B. W. Kennedy, F.R.S., Sir E. Ray Lankester, K.C.B., F.R.S., Dr. J. A. H. Murray, Prof. C. S. Sherrington, F.R.S.; (2) as *Foreign Honorary Fellows*, Prof. Emil Fischer, Berlin; Dr. G. W. Hill, New York; Prof. F. W. G. Kohlrausch, Charlottenburg; Prof. H. F. Osborn, New York; Prof. I. P. Pavlov, St. Petersburg; Prof. G. Retzius, Stockholm; Prof. A. Righi, Bologna; Prof. L. J. Trost, Paris.

The meeting of the second International Conference on the Sleeping Sickness, which was to have assembled at the Foreign Office on November 1, has been postponed in order that the delegates may have before them the results obtained by Prof. Koch, who has lately been carrying out an exhaustive inquiry into the subject on the spot, and is now engaged in the preparation of his report. The conference will probably not meet before the middle of February. The British delegation will consist of Lord Fitzmaurice, Sir Walter Foster, M.P., Mr. A. Walrod Clarke, Mr. H. J. Read, Sir Patrick Manson, K.C.M.G., Colonel David Bruce, C.B., F.R.S., Dr. J. Rose Bradford, F.R.S., and Sir Rubert Boyce, F.R.S.

A COMMITTEE having for its object the collection of information dealing with sleeping sickness, the stimulation of research into the cause, method of transference, and cure of the disease, and the publication from time to time of communications with reference to it, has been formed at Liverpool. The committee comprises Sir Alfred Jones (chairman), the Lord Mayor of Liverpool, Prof. Moore, Prof. Salvin-Moore, Prof. Annett, Prof. Sherrington, F.R.S., Dr. Stephens, Dr. Anton Breinl, Dr. Prout, C.M.G., Dr. A. Evans, Dr. M. Nierenstein, Mr. J. W. Garrett, and Dr. J. L. Todd. Sir Rubert Boyce, F.R.S., and Mr. A. H. Milne are the corresponding secretaries.

A DESPATCH recently received at Washington from Lieut. B. H. Camden, commanding a revenue cutter in Alaska, reports the entire disappearance of McCulloch Peak, Bogoslof Island (which rose from the sea in 1796), as the result of volcanic disturbances. The explosion which destroyed this peak has been followed by remarkable changes in the profiles of Mount Makush and neighbouring mountains, which are now softened to a general symmetry by a padding of lava dust that has almost disguised them beyond recognition. A vast quantity of this material, hundreds of feet in depth, has been deposited over the entire island.

It is announced in *Science* that the Field Museum of Natural History, Chicago, has profited by a decision of the Chicago Probate Court to the extent of \$6,000. The money was paid by the late Mr. Marshall Field to the trustees of the museum prior to the date of his will, which contained a bequest of 1,600,000. to the institution. A suit was brought by the trustees against the executors of the will to determine whether the bequest was intended to be exclusive of the amount previously donated. The judge decided the suit in favour of the museum. From the same source we learn that about four acres of ground have been set apart in the block adjoining Washington Park and the Midway Plaisance to serve as a botanic garden for the University of Chicago. The garden will

be easily accessible from the Hull Botanical Laboratory, and is to be strictly a laboratory garden, which will add greatly to the facilities for experimental work. The area, it is hoped, will be largely increased later.

THE Home Secretary has appointed a departmental committee to inquire into the subject of artificial humidity in cotton-weaving factories. The members of the committee are Sir Hamilton Freer-Smith (chairman), Mr. J. Cross, Mr. H. Higson, Mr. T. Roberts, Mr. D. J. Shackleton, M.P., and Prof. J. L. Smith. The terms of reference to the committee are to inquire and report:—(1) what temperature and humidity are necessary in each case for the manufacture of different classes of cotton fabrics; (2) at what degrees of temperature and humidity combined definite bodily discomfort arises under the conditions of the work carried on by the operatives, and what, if any, danger to health is involved by continuous work at those degrees; (3) what means of cooling humid sheds (where necessary) exist, whether combined with the means of humidifying or otherwise, which are both efficient and practicable, having regard to the conditions required for the manufacture of the several classes of goods; (4) what special arrangements, if any, are necessary in order to admit of the proper ventilation of dry weaving sheds without prejudice to the process of manufacture. The secretary to the committee is Mr. D. R. Wilson, to whom correspondence may be addressed at the Factory Department, Home Office.

ONE of the most famous establishments for the distribution of new and rare plants in this country is that of James Veitch and Sons, Ltd., Chelsea, the late managing director of which company died on November 13 at Exeter at the age of thirty-nine years. Mr. James Herbert Veitch was a son of John Gould Veitch, who died in 1870. The son was admitted to the firm whilst still young, and when he was twenty-three years of age was sent on a botanical tour to Australia, New Zealand, India, Corea, and Japan, a tour which occupied a period of two years. After his return, Mr. Veitch published in "A Traveller's Notes" some impressions he had obtained in regard to the public and private gardening and botanical establishments he had visited for the purpose of studying the cultivated plants in those countries, and obtaining information as to the possibility of introducing new species to English gardens. After the lapse of several years he was appointed managing director of the Chelsea business, and continued to discharge the responsibilities of that position until last year, when failing health compelled him to retire from business. During the time he was managing director, a special representative was dispatched to the western portion of China, approaching to Tibet, for the purpose of collecting new species of plants suitable for cultivation in English gardens. The collector, Mr. E. H. Wilson, visited China twice, the two visits occupying a period of four years, and, as a result, a large number of new species of decorative trees and shrubs, conifers, perennial herbaceous flowering plants, and some biennials were secured. One species that has already become common in gardens is the Tibetan poppy (*Meconoopsis integrifolia*), and others that have been distributed include species of *Senecio*, *Vitis*, *Davidia*, *Berberis*, *Buddleia*, *Clematis*, *Corydalis*, *Cypripedium*, *Deutzia*, *Jasminum*, *Primula*, *Rubus*, and many other genera. Mr. Veitch rendered a good service to botanical and horticultural literature by publishing last year the "Hortus Veitchii," which contains short descriptions and references to publication of most of the exotic plants introduced to British

gardens by the firm of Veitch during a period of more than fifty years.

In the introduction to a paper on parasites of Bermuda fishes, published in the Proceedings of the U.S. National Museum (No. 1560), Mr. Edwin Linton observes that fishes from the inner reefs appear to be free from encysted parasites than those living on the outer reefs and in deep water outside. This he explains by the fact that, owing to the exceeding clearness of the water, sharks, which are the great dispersers of cestode ova, do not frequent the shoal-water. In contrast to the comparative immunity enjoyed by the shallow-water forms is the strong infestation of the deep-water species, the large "groupers" and rock-fish, living at a depth of about fourteen fathoms, harbouring numerous encysted cestodes on the viscera, more especially the walls of the stomach.

THE young stages of two fresh-water American crayfishes form the subject of an elaborate memoir by Prof. E. A. Andrews, of the Johns Hopkins University, published in the Smithsonian Contributions to Knowledge (vol. xxxv., No. 1718). Of the two genera, *Cambarus* is limited to North America east of the Rocky Mountains, while *Astacus* is common to the Pacific slope of the northern half of the American continent and the two great northern continents of the Old World. As the former is the more specialised form of the two—more especially as regards the adaptation of the young for a life of association with the female parent—it is a reasonable hypothesis that the group reached the New World by way of what is now Bering Strait, while the evolution of *Cambarus* from *Astacus*-like ancestors took place in the region of Mexico. In regard to the latter part of this theory, it might, we think, be stated that the evolution took place from *Astacus* itself, seeing that this genus is common to both hemispheres. The larval stages of the two genera are found to differ in a number of important particulars, and other results of the investigation furnish a basis for practical application to the problems of the artificial cultivation of crayfishes and the introduction of new species.

In the October issue of the *Emu* Mr. A. H. Mattingley gives some harrowing details of the results of the visit of a party of "osprey"-plume hunters to a colony of egrets. The writer had visited the site some months previously, when all was well, but on re-visiting the place at Christmas it soon became evident that mischief had been done. "As we drew nearer, what a spectacle met our gaze—a sight that fairly made my blood boil with indignation. There, strewn on the floating water-weed, and also on adjacent logs, were at least fifty carcasses of large white and smaller plumed egrets—nearly one-third of the colony, perhaps more—the birds having been shot off their nests containing young. . . . There were fifty birds ruthlessly destroyed, besides their young (about 200) left to die of starvation! This last fact was betokened by at least seventy carcasses of nestlings. . . . which had fallen from the nests into the water and been drowned; while in the trees above the remainder of the nestlings could be seen staggering in the nests." Some of these unfortunates fell from time to time into the water, others died of inanition as they sat, while yet others stretched out their necks in the vain attempt to attract the attention of others of their own kind as they flew by with food in their beaks.

ACCORDING to the report for October, the additions to the Zoological Society's menagerie during that month were 214 in number, of which 107 were acquired by presentation

and three by purchase, while ninety-two were received on deposit, ten by exchange, and two were born in the gardens. Special attention is directed by the secretary to the following:—two chinchillas (*Chinchilla lanigera*), presented by the Countess De Grey; five viscachas (*Lagostomus trichodactylus*), three presented by the Countess De Grey and two deposited; a spotted cuscus (*Phalanger maculatus*), a species new to the collection, purchased; and a naked-throated bell-bird (*Chasmorhynchus nudicollis*), a ground-hornbill (*Bucorvus abyssinicus*), and two Arizona poisonous lizards (*Heloderma suspectum*), deposited.

THE University of California continues its useful series of publications on the religion, sociology, and languages of the Indian population of the State. The most valuable of those recently issued is a monograph, by Mr. A. L. Kroeber, on the religion of the Indians of California. This is a form of Animism; but its distinguishing characteristic is the strong belief in Shamanism, generally in connection with disease and death. Dancing, always accompanied by singing, is a conspicuous element in all tribal ceremonials. In one tribe the dance is performed by the women, who stand up to their hips in water. The author gives full details of the mode in which the Shaman or medicine-man is initiated. The profession, though lucrative, can hardly be said to be desirable. Among some tribes, if he loses several patients in succession, he is held responsible by the relatives; in another, murder seems to be his normal end; in a third, if he fails to cure, he is obliged to return his fee. The author also gives a most interesting account of the rites of initiation for girls and boys, of the domestic and tribal celebrations, and of the mythology and popular beliefs. In a second paper he furnishes an elaborate analysis of the Washo language of east central California and Nevada. It is satisfactory to learn that the University has acquired the large MS. collections on the North American Indians made during a long service among them by the late distinguished scholar, Dr. Washington Matthews. These are now being published, the first instalment being a collection of Navaho myths, prayers, and songs, with the text and a translation.

THE importance of algal growth in the colonisation of new ground is well recognised, but there are few records of detailed examination, so that the paper contributed by Dr. F. E. Fritsch to the *Geographical Journal* (November), embodying primarily the results of observation in the tropical climate of Ceylon, furnishes valuable data for reference and for extended inquiry. The blue-green algae, by reason of their colour and sheaths, are peculiarly protected against insolation and desiccation, and therefore comprise the bulk of aerial algal colonies in Ceylon. Dr. Fritsch distinguishes four methods of growth, which he calls *adhesive*, *tangled*, *tufted*, and *stratified*. The adhesive is the earliest and simplest type; tangled and tufted colonies, being better adapted as regards respiration and water absorption, proceed from the adhesive; the stratified form is a special modification determined by light or possibly by moisture conditions.

THROUGHOUT Germany the moors form an important feature of the vegetation, and on this account have engaged the attention of botanists, who have investigated their origin and formation. With the view of providing ocular demonstration of their development, Dr. C. A. Weber has designed two attractive coloured plates indicating in section elevation the different strata that have formed successive stages in the production of a moor. The diagram of the low-moor pictures the various zones from a mineral substratum

through rush-turf to coniferous forest. The plate illustrating the high-moor decked with cotton grass shows additional layers, notably sphagnum-zones superposed. The plates, measuring 110 cm. by 150 cm., are published by Gebrüder Borntraeger at the price of twenty shillings, or mounted on linen thirty-two shillings, a pair. The same firm is also publishing a set of plates illustrating pharmaceutical products at a subscription price of twenty-five shillings for five plates. A specimen plate of *Lignum Guaiacum* bears figures of wood and cortex as seen in different sections, also of the broken elements. The plates have been drawn by Mr. J. Pohl under the direction of Dr. E. Gilg.

THE latest Bulletin (No. 26) issued by the Geological Survey of Western Australia contains a series of miscellaneous reports which in themselves are not of sufficient length to warrant issue as separate publications. The volume covers eighty-seven pages, and contains fourteen illustrations and six maps. Mr. A. Gibb Maitland contributes papers on the occurrence of artesian water in the Northampton and Geraldine district, on the geology of Princess Royal Harbour, with special reference to the occurrence of petroleum, and on recent advances in the knowledge of the geology of Western Australia. Mr. H. P. Woodward gives an account of the geology of the country between the Ashburton and Minitiya rivers. Mr. W. D. Campbell describes the phosphatic deposits near Dandaraga. The discovery is one of great value to the State. The deposit occurs in a series of beds which have been followed for twenty-two miles, one bed of fossil bone and coprolite rock, 7 feet in thickness, containing 15-32 per cent. to 39-34 per cent. of phosphoric acid. Mr. W. D. Campbell also contributes some notes on a geological map of the Greenough River district. Mr. E. S. Simpson describes a small meteorite, a siderite of the octahedrite type weighing 120.2 grams, from the Nuleri district of Western Australia. He also contributes a valuable report on the prevention of the external corrosion of goldfields' water-supply pipes. The Survey is to be congratulated upon the issue of these reports in a collective form, as they cannot fail to help to make known the varied mineral resources of Western Australia.

A THOROUGH change has occurred in the type of the weather during the past week, and more wintry conditions than at any time this season have been experienced. Night frosts have occurred in many parts of the country, and heavy snow has fallen over the northern portion of England. Cyclonic disturbances continue to arrive from the Atlantic with considerable frequency, and at times these are accompanied by winds of gale force. On Monday a whirlwind was experienced in the neighbourhood of Deal, and some farm buildings sustained considerable damage. The autumn has, on the whole, been exceptionally mild, the day and night temperatures being generally at least 5° above the average.

WE have received the fourteenth annual report of meteorology in Mysore, being the results of observations at Bangalore, Mysore, Hassan, and Chitaldrug for 1906. To the present report the daily means for the twelve years 1893-1904 have been added for each of those important stations. The director (Mr. J. Cook) states that, in accordance with the recent action of the Government of India, which has reduced the majority of its second-class observatories to third-class ones, the last two of the above-mentioned stations will hereafter be of the third class. For this reason the twelve-year means now published for

those places will be valuable as climatic standards of reference.

An important article by Captain Tancredi in the *Rivista Coloniale* on the climate of the Italian colony of Eritrea, from observations at fourteen stations, is summarised in the Quarterly Journal of the Royal Meteorological Society for October. The observations at Massaua extend over ten years, and these, so far as regards temperature, rainfall, and humidity, have also been discussed with others extending (with small interruptions) over eighteen years (1885-1902) by Drs. Eredia and Memmo in the Bulletin of the Italian Geographical Society. The lowest of the mean monthly minima, 72°·3, occurs in January, and the mean maximum, 103°·1, in July; the mean yearly temperature is 86°·0. The year may be divided into two periods; from May to October the monthly means are above, and from November to April below, the mean value. The average annual rainfall is small, being only 7·19 inches, of which 6·04 inches fall between October and March; none falls in June. Malaria depends especially upon the altitude; places above 6000 feet are practically free from it, while in the low-lying regions it is endemic, and assumes an epidemic character in some months, apparently depending upon the régime of the rainfall in the locality.

THE Smithsonian Institution has published ("Miscellaneous Collections," xlix.) a memorial of the late Prof. S. P. Langley, accompanied by a bibliography of his published writings. It contains addresses by Dr. Andrew D. White, dealing with biographical details; by Prof. E. C. Pickering, dealing with Prof. Langley's contributions to astronomy and astrophysics; and by Mr. Octave Chanute, dealing with his contributions to aerodynamics. The last-named address is of considerable interest in consequence of the conflicting statements which appeared in the Press at the time in reference to the alleged success or failure of Langley's experiments on aeroplane flight. The facts of the case as chronicled by Mr. Chanute will now become a matter of history.

IN the Proceedings of the Edinburgh Mathematical Society (xxv.), Mr. R. F. Muirhead directs attention to a simple method of calculating first and second moments of certain elementary figures. By "second moments" are meant the same as "moments of inertia," the term being preferred, as it does not imply that we are concerned with masses. The method in question, or one very similar to it, was known at Cambridge many years ago, but does not seem hitherto to have been much discussed in print. As applied to the triangle, this method consists essentially in dividing a triangle into four smaller triangles by joining the middle points of the sides, and applying Huyghens's principle of parallel axes to obtain a relation between the moments of the original triangle and the four smaller ones.

AN interesting account of the Amalgamated Radio-Telegraph Company's new Transatlantic wireless station at Knockroe appears in the *Electrician* of November 15. The station is nearly completed, and when finished an Atlantic shipping service will be started, while as soon as the Canadian station is opened a Transatlantic service will be commenced. Three masts, 350 feet high, carry the insulated ends of some 300 wires, which descend in a cone to nine shorter masts, 70 feet high, erected in a circle about the taller ones. The Poulsen system of wireless telegraphy by undamped waves is employed, and it will be interesting to compare the Marconi and the Poulsen systems in a Transatlantic service. Possibly in this station

a higher voltage than that usually employed in the Poulsen system—400 to 500 volts—may be found necessary, but otherwise the apparatus installed does not differ very considerably from that at other stations. A great many improvements have been made in the different parts of the apparatus since Mr. Poulsen gave a demonstration of his system at the Queen's Hall, a full account of which appeared in these columns at the time (*NATURE*, vol. lxxv., pp. 105, 106), and the transmitter at Knockroo station has been designed to transmit waves 3000 to 5000 metres long, and capable of giving the desired wave-length without any variation. The company has also a new thermo-electric detector with which it expects to print Transatlantic messages, and in consequence to be independent of telephonic reception. The Poulsen-Pedersen "ticker" method of reception also has been adapted to working a relay and a Morse inker. This "ticker" receiver has been greatly improved upon, and the latest form recently established a long-distance record, receiving a ship signal at a distance of 2060 miles.

THE theory of the formation of the rainbow has been worked out more completely than hitherto by Prof. T. Tanakadate in the August number of the Proceedings of the Tokyo Mathematico-Physical Society. Taking account of the loss of light on reflection and refraction, and of the effect of polarisation, the author follows Airy's treatment, and obtains an expression for the intensity of light of each of the four bows due to drops of a particular size, in a form suitable for numerical calculation.

In the *Physical Review* for October Prof. W. S. Franklin and Mr. L. A. Freudenberger describe an arrangement they have found very satisfactory for measuring the resistance of electrolytes without the use of electrodes. The electrolyte is placed in an annular glass tank which encircles the iron of a small transformer the primary of which forms one arm of a resistance bridge. In the corresponding arm of the bridge a similar transformer is placed, and the resistance of its secondary adjusted until the bridge is balanced, when an alternating current is supplied to it. The apparatus is so simple and the results are so good that electrodeless methods should replace some of those at present in use.

THE *Physikalische Zeitschrift* for October 24 contains abstracts of many of the papers read at the *Versammlung deutscher Naturforscher und Aerzte* in Dresden in September. The meeting, owing largely to the exertions of Prof. Hallwachs, was very successful. Of many papers of great interest, two may be mentioned. Drs. E. Gehrcke and O. Reichenheim have measured the change of wave-length of the light of the anode rays when they are seen end on, and have shown that when the anode is of sodium, lithium, or strontium the rays consist of molecules of these metals thrown off from the anode. Drs. Scheel and Heuse have measured the expansion of platinum between -183° C. and $+16^{\circ}$ C., and find as the mean result of three determinations by the two-microscope method and by Fizeau's method 1602×10^{-4} cm. per centimetre.

ARRANGEMENTS are being made by which the Proceedings of the London Mathematical Society may be subscribed for by the public at a uniform price per volume, the volumes to be supplied either in parts, as issued, or in volumes at the option of the subscriber. The arrangement will begin to take effect with the next volume, the first part of which will probably be published early in January, 1908.

THE *Anglo-German Courier* of November 23, published by the *African World*, is entirely devoted to an illustrated description in German and English of the recent visit of

the German Emperor and Empress to London. This is the final number of that periodical, which was started to promote friendly feelings between the people of Great Britain and Germany—a mission that may now be regarded as accomplished.

Two well-illustrated and conveniently arranged catalogues have been received from Messrs. Casella and Co. One deals with self-recording instruments for scientific, engineering, and industrial purposes, and the other provides descriptions of anemometers, air meters, and wind-direction instruments. The catalogues deserve the attention of meteorologists, teachers of geography, and other observers.

A SECOND English edition, which has been re-written, of Prof. A. F. Hollemann's "Text-book of Organic Chemistry," has been published in this country by Messrs. Chapman and Hall, Ltd., and by Messrs. John Wiley and Sons in New York. The first English edition was reviewed in *NATURE* of June 18, 1903 (vol. lxxviii., p. 149), and it will suffice to say that the present volume is, like the former, the translation of Dr. A. Jamieson Walker, and is from the third Dutch edition. The translator has had the cooperation of the author and the assistance of Dr. Owen E. Mott.

MESSRS. J. M. DENT AND CO. have published the first number of the *New Quarterly*, a review of science and literature, edited by Mr. Desmond MacCarthy. The price of each issue is 2s. 6d. net. If science is to receive the same amount of attention in subsequent numbers, the review should become popular in the scientific world. Of the nine articles included in the present issue, four deal with various departments of scientific work. Lord Rayleigh, P.R.S., discusses the question, "How do we perceive the direction of sound?" The Hon. Bertrand Russell writes on the study of mathematics; the Hon. R. J. Strutt, F.R.S., deals with the question, "Can we detect our drift through space?" and Mr. G. A. Paley contributes an article on biology and politics.

OUR ASTRONOMICAL COLUMN.

ASTRONOMICAL OCCURRENCES IN DECEMBER:—

- Dec. 1. 2h. Mercury at greatest western elongation ($20^{\circ} 20'$).
 3. 18h. 30m. Mercury 4° W. from the Moon.
 7. 11h. 42m. Minimum of Algol (β Persei).
 10-13. Epoch of the Geminid meteoric shower.
 10. 17h. Mars in conjunction with Moon. (Mars $3^{\circ} 25' S.$).
 10. 8h. 31m. Minimum of Algol (β Persei).
 11. 22h. Venus in conjunction with Uranus (Venus $5^{\circ} 59' S.$).
 12. 3h. 35m. to 4h. 28m. Moon occults 30 Piscium (mag. 4.7).
 ,, 5h. 28m. to 6h. 42m. Moon occults 33 Piscium (mag. 4.6).
 13. 5h. 20m. Minimum of Algol (β Persei).
 ,, 3h. 54m. to 4h. 44m. Moon occults 20 Ceti (mag. 4.9).
 15. 2h. 55m. to 3h. 47m. Moon occults $2^{\frac{1}{2}}$ Ceti (mag. 4.3).
 17. 12h. 53m. to 13h. 18m. Moon occults $3^{\frac{1}{2}}$ Tauri (mag. 3.9).
 ,, 14h. 9m. to 15h. 18m. Moon occults $3^{\frac{3}{4}}$ Tauri (mag. 4.2).
 20. 22h. Vesta in conjunction with the Moon. (Vesta $5^{\circ} 59' S.$).
 22. 12h. Sun enters Capricornus. Winter commences.
 23. 2h. 6m. Jupiter in conjunction with Moon (Jupiter $1^{\circ} 53' S.$).
 30. 10h. 14m. Minimum of Algol (β Persei).
 31. 3h. Mars in conjunction with Saturn. (Mars $1^{\circ} 50' N.$).

SATURN'S RINGS.—Further observations of the invisibility of Saturn's rings during the recent passage of the earth through the plane containing them are recorded in No. 4215 (p. 249, November 17) of the *Astronomische Nachrichten*. According to the calculations of Prof. B. Peter, of Leipzig, the second disappearance should have taken place on October 4. M. Schaer, of Geneva, saw the rings as a luminous line without any difficulty on October 2, using a reflector of 140 mm. aperture. On October 3 the weather was unfavourable, but the rings were still visible, with a reflector of 160 mm. aperture, at 6h. 45m. on October 4. At 7h. 30m., however, the last trace of the bright line had disappeared. Continuing the observations with a refractor of 34 cm. aperture, at 7h. 45m. the rings could be seen momentarily, but were totally invisible at 8h. Bands of a brownish tint were several times seen on each side of the trace of the rings.

Dr. Hassenstein made observations with the 13-inch refractor at Königsberg on October 1 and 3. At 8h. (G.M.T.) on the former date the rings were undoubtedly visible, but at 5h. (G.M.T.) on October 3 they were invisible; at 10h. the rings could not be seen, but dark streaks and the shadow of the rings were visible. Dr. Hassenstein concludes that the passage of the earth through the plane of the rings took place at oh. (G.M.T.) on October 3.

PHOTOGRAPHS OF JUPITER.—The November number of the *Bulletin de la Société astronomique de France* (p. 481) contains a reproduction from a photograph of Jupiter taken by M. Quéisset at the Juvisy Observatory on March 2. The instrument employed was the Viennet objective of 0.16 m. (6.3 inches) aperture and 2.9 m. (11.4 inches) focal length, and about 100 exposures were made. The resulting images show many details, and some of them are remarkably well defined, presenting nearly all the details seen with the 240 mm. equatorial at the same time. On some of the photographs the Great Red Spot is even more apparent than in the visual observation. A reproduction from a drawing made forty minutes earlier shows how well the details are registered on the photograph.

The same journal contains reproductions from Prof. Lowell's photographs of Mars taken on July 11 and 28 respectively.

FINAL DESIGNATIONS OF RECENTLY DISCOVERED VARIABLES.—No. 4212 of the *Astronomische Nachrichten* (p. 181, November 7) contains a table giving the final designations of recently discovered variable stars allotted by the commission of the A.G. catalogue for variable stars. The list gives the provisional and final designations, the position for 1900, the precession, the chart place, and the range of magnitude for each variable, and includes twenty-four variable stars of long period, eleven irregular and twenty-five short-period objects, and thirteen variables of the Algol type.

A LARGE ERUPTIVE PROMINENCE.—Four excellent photographs of a large eruptive prominence, taken by Mr. Fox on May 21 with the Rumford spectroheliograph of the Yerkes Observatory, are reproduced in No. 3, vol. xxvi., of the *Astrophysical Journal* (October, p. 155). On the first photograph the prominence was seen strongly attached to the sun's limb, but on the succeeding plates it is shown as greatly altered in form and considerably weakened in its lower parts. Thirteen plates were exposed, using the H line, between 4h. 2m. and 5h. 50m., and during that period the height of the prominence, as measured on the photographs, varied as shown in the following table:—

G. M. T.		Height		G. M. T.		Height		
h. m.	°	kms.	miles	h. m.	°	kms.	miles	
4	2	228.6	167,800	103,200	5	44	370.4	271,900
5	1	280.3	205,800	126,500	5	55	423.3	310,700
5	43	431.8	316,900	196,800	5	59	412.7	303,000

SURVEYS OF NEBULÆ.—Future workers on the possible changes in nebulae or in the stars involved in such masses will find the exhaustive surveys of the Andromeda, the ξ Persei, and the 12 Monocerotis nebulae, recently carried

out at the Astrophysical Institute, Königstuhl-Heidelberg, of invaluable assistance.

The results of these surveys are published at length in the *Publikationen* of the institute, No. 1, vol. iii., containing those obtained by Herr P. Götz from his researches on the Andromeda nebula, and No. 11, vol. ii., embodying Herr Lohmert's results concerning the star-densities of the nebulae near ξ Persei and 12 Monocerotis respectively. The former treats of 1259 stars involved in the great spiral nebulae, and gives the position and magnitude of each star for the equinox of 1900; then follows a catalogue of fifty-four recognisable points in the nebula which have been measured, and of which the positions (1900) are given. The treatise concludes with a detailed description of the nebula, a discussion of the relation of the star-density to the form and brightness of the gaseous mass in various parts, and the results of a statistical investigation of the distribution of the stars. Among other results, Herr Götz finds that all the stars concerned are fainter than the ninth, whilst sixty-four are fainter than the sixteenth, magnitude. The greatest number, taken in magnitudes, are between magnitude 14.0 and 15.0, there being 316 of this class.

Herr Lohmert's work deals similarly with the distribution of the stars in the other two nebulae named, the results being given in tables and also shown diagrammatically, as are those appertaining to the Andromeda research.

NEW GEOLOGICAL SURVEY MAPS AND MEMOIRS.¹

(1) THE Geological Survey is making rapid progress in the publication of its re-survey of Cornwall; the memoir on the geology of Falmouth and Truro (Sheet 352) has already been reviewed in NATURE, and that on the Newquay district was described in the issue for May 16. Now we have the Penzance sheet of the map (adjoining that of Falmouth), and an explanation thereof.

This area includes not only the "Land's End district," including Penzance and St. Ives, but also the neck of land which unites it to the rest of Cornwall. The district possesses several interesting physical features, for the granite areas up to a height of about 420 feet above the sea exhibit smooth and undulating contours, the ground forming a dissected plateau and rising gently to the foot of a well-marked bluff, which is an ancient sea-cliff. The age of this plateau cannot be fixed for certain, and though Mr. Reid seems inclined to refer it to early Pliocene time, he admits that it may be much older (? Eocene), and may only have been re-modelled and graded in Pliocene times. The low-lying neck of land which lies between Mounts Bay and St. Ives Bay has also an interesting history; originally it may have been part of an Eocene river-valley, but in Pliocene times it was a strait, and the Land's End district was then an island.

The most important rock-masses delineated on the colour-printed map and described in the memoir are:—(1) the three members of the Lower Palaeozoic system, which are probably of Ordovician age, but have received local names in Cornwall—the Mylor series, the Falmouth series, and the Portscatho series; (2) the masses of intrusive igneous rock—granite and greenstone—which have been thrust through these ancient strata.

The contact-alterations produced by these successive intrusions are fully explained. The greenstones (diabasic rocks) are earlier than the granite, and their effects are different from those produced by the latter. Each area of granite is surrounded by an aureole or belt of altered rock, and the border of the granite itself has been converted into schorl-rock (quartz and tourmaline). It is in these altered belts and in the adjacent parts of the granite that the principal mineral wealth of the country has been found.

There is a chapter on the clivans or dykes of quartz-
 1 (1) "The Geology of the Lands End District." By Clement Reid, F.R.S., and Dr. J. S. Flett, with contributions by Messrs. Wilkinson, Dixon, Pollard, and MacAlister. Pp. viii+158; with six plates. (London: H.M. Stationery Office, 1907). Price of memoir 3s. 6d., of map 2s. 6d.
 (2) "The Geology of the Country around Hungerford and Newbury." By H. J. Osborne White. Pp. iv+150; illustrated. (London: H.M. Stationery Office, 1907). Price of memoir 2s. 6d., of map 1s. 6d.

porphyry which traverse the district, and are of slightly later date than the granite. Fifty-seven pages are devoted to economic geology and mining, much information being given about the mineral lodes and the mines, some of which are now being re-opened.

Brief accounts are given of the Pliocene deposits of St. Erth and of the later Pleistocene accumulations.

The photographic views are clear and well reproduced, as may be seen from the example here given. The map is well printed on good thick paper, and the only fault we have to find with the colouring is that the tints indicating Pliocene and Valley Gravel are barely distinguishable from one another.

(2) The second memoir deals with an area which includes parts of Berkshire, Wiltshire, and Hampshire, the larger portion being in Berkshire and traversed by the valley of

found in two small outliers, which are due to shallow synclinal flexures.

By aid of this zonal work Mr. White is able to show the exact nature and extent of the unconformity between the Chalk and the Eocene. This proves to be a gradual overstep, the Eocene passing progressively on to older and older beds in a northerly direction. Hence it would seem that, prior to the Eocene sedimentation, the whole area had a continuous slope from north to south, and that the Kingsclere-Pewsey anticline is entirely of post-Eocene date.

Chapters are devoted to the Reading beds, the London Clay, the Lower Bagshot beds, the Clay-with-Flints, the Plateau Gravel, the valley gravels, alluvium, and economics. There are also appendices on the Mollusca of the alluvium of the Kennet by Messrs. A. S. Kennard and B. B. Woodward, and on the insoluble matter in



View of the south side of the Land's End. From "The Geology of the Land's End District."

the Kennet. Nothing older than the Selbornian (Upper Greensand) reaches the surface, and the greater part is occupied by Chalk, Eocene beds, and Clay-with-flints. The colouring of the map is clear, and the paper on which it is printed is thicker than that of sheets issued in previous years.

It is some time since this area was surveyed, and in the meantime Mr. Osborne White has made a detailed study of the Chalk and its zones in Berkshire, as well as of the superficial deposits of this and neighbouring districts, so that the preparation of the memoir could not have been put into better hands.

Of the Cretaceous rocks described, the chief interest centres in the Upper Chalk, which is dealt with zone by zone; two of these, the zone of *Marsupites testudinarius* and that of *Actinocamax quadratus*, have only been proved to exist in Berkshire within the last three years. The former has a continuous outcrop from the western border as far east as Newbury, and this outcrop is indicated on a sketch-map in the memoir; but the higher zone is only

samples of Upper Chalk by Dr. W. Pollard and Mr. H. H. Thomas. Finally, the memoir is furnished with a bibliography and a good index.

RECENT PUBLICATIONS OF THE U.S. MUSEUM.¹

THE subjoined list (which is exclusive of a large number of minor publications) affords a striking example of the energy with which scientific research is being pushed in America, a noteworthy fact being that,

¹ (1) "The Birds of North and Middle America." Part iv. By R. Ridgway. Bull. U.S. Nat. Museum, No. 50. Pp. xxii+973.

(2) "Catalogue of the Type and Figured Specimens of Fossils, Minerals, Rocks, and Ores in the Department of Geology, U.S. Mus." Part II. By J. P. Merrill. *Op. cit.*, No. 53. Pp. v+370.

(3) "The Families and Genera of Bats." By G. S. Miller. *Op. cit.* No. 57. Pp. xvii+332.

(4) "Herpetology of Japan and Adjacent Territory." By L. Stejneger. *Op. cit.*, No. 58. Pp. xx+357.

(5) "Report on the Diatoms of the *Albatross Voyages in the Pacific Ocean, 1898-1904*." By Albert Mann. Contr. U.S. Nat. Herbarium, vol. x., part v. Pp. v+221-424.

out of the five memoirs, only two are devoted solely to American biological subjects. Since all five are by well-known experts, the following brief remarks may in the main take the form of commendation rather than of criticism.

As regards No. 1, Mr. Ridgway is to be congratulated on having got through rather more than half his heavy task, the present part bringing him nearly to the conclusion of the perching birds, of which no less than 1675 species and races are recorded in the first four parts. As in the previous volumes, generic terms are employed in the modern restricted sense, and the "keys" to the various family and generic groups are all that can be desired in the way of lucidity and comprehensiveness.

The catalogue standing as No. 2 in our list is a work exclusively for the benefit of specialists, to whom it will no doubt prove invaluable. The invertebrates having been completed in the first part, the present issue is devoted to fossil vertebrates, fossil plants, and minerals, rocks, and ores, which are severally arranged in three main sections. In the vertebrate section the specimens are referred to their respective classes, in which they are catalogued according to the alphabetical order of their names. This seems, on the whole, the most satisfactory arrangement; but we venture to think that the author has carried the alphabetical plan a little too far in making it extend to the class-divisions, the sequence of birds, fishes, mammals, and reptiles being, in our opinion, decidedly unsatisfactory. The system of cross-references in cases where a specimen has been referred to more than one genus is well planned, but the addition of a species index to each section or class would have considerably added to the value of the catalogue as a work of reference.

With No. 3 we come to a work of prime importance, which cannot fail to be of the highest value to systematists. No complete revision of the families and genera of bats has, we believe, been published since the issue of Dobson's invaluable catalogue, and as great progress in our knowledge of the group has been made since that date, such a revision was urgently wanted. For this task few zoologists are better equipped than Mr. Miller, who for some years past has devoted much attention to the order, and has studied the chief collection on both sides of the Atlantic. Perhaps the most important divergences from the Dobsonian classification are the wide sundering of the Emballonuridae and Vespertilionidae, and the transference of the mastiff-bats from the former group to a separate family following the latter; the second change being a further development of one inaugurated by Winge and endorsed by Max Weber.

Dr. Stöjeger's work on the reptiles of Japan, the Liu Kiu and neighbouring islands, and a considerable proportion of the mainland of the Far East, will take rank as a valuable systematic monograph, in which special attention is devoted to geographical distribution.

In his memoir on the Pacific diatoms collected by the *Albatross*, standing last on our list, the author directs attention to the importance of collecting these organisms on account of their value in determining difficult questions connected with the extent and volume of ocean currents, and the origin of the materials deposited on the bed of the sea. Now that this has been pointed out, there is little doubt that the authorities will see their way to the collection of diatoms in a much more careful and systematic manner than has hitherto been attempted in America. R. L.

UNIVERSITY AND EDUCATIONAL INTELLIGENCE.

CAMBRIDGE.—The board of anthropological studies has put forward a proposal to establish a diploma in anthropology. The board believes that the interests of anthropology will be best served by the encouragement of research, and that the proposed diploma in anthropology should be granted for an original dissertation, and not by examination.

On the recommendation of the general board of studies the readership in animal morphology is to be transferred to the more general subject of zoology. It is proposed

NO. 1987, VOL. 77]

that the board be authorised to appoint a reader in zoology with the annual stipend of 100*l.*, to be paid from the common university fund. The board also proposes that a demonstrator in petrology be appointed.

Mr. W. Welsh has been appointed chairman of the examiners for part i. of the mathematical tripos, 1908 (new regulations).

Prof. Ridgway, the Disney professor, gives notice that he will maintain the thesis "that Sergi's theory of the Mediterranean race is untenable," on Wednesday, December 4, at 5 p.m., in the archaeological lecture-room.

LONDON.—At the meeting of the Senate on November 20 a report was received from the committee specially appointed to advise the Senate on the question of the establishment of the proposed Institute of Medical Sciences at South Kensington. The committee found that the financial support offered for the original scheme was inadequate, and that, apart from the money difficulty, the scheme had become impracticable on account of the opposition of the medical faculty. The Senate therefore decided that the donors to the fund should be informed that the money paid was at their disposal.

Prof. Starling, F.R.S., has been elected by the medical faculty a member of the Senate, in succession to Dr. Lauriston Shaw, resigned.

MANCHESTER.—A deputation from the University, supported by the members of Parliament and municipal authorities of Lancashire and the surrounding counties, waited upon the Chancellor of the Exchequer on November 20 in reference to the proposed reduction of the Government grant to the University from 12,000*l.* to 10,000*l.* per annum. Throughout this district numerous public bodies interested in higher education have passed resolutions expressing disappointment at the recommendation of the advisory committee, and requesting the Government to continue its full support. The Vice-Chancellor gave evidence to show that this reduction in the grant will seriously hamper the steps which have been taken to develop in various directions the higher branches of the work of the University. The Chancellor of the Exchequer emphasised the determination of the Government not to reduce the total grant of 100,000*l.* devoted to higher education, but, whilst admitting that there was no suggestion that the work of the University had been slackened in any of its departments, pointed out that the advisory committee was unbiased and free from pressure from any quarter. Further consideration of the case was promised. Quite apart from its local effect, the "principle of a maximum" is regarded here as one of great danger to the advance of higher education. The *Manchester Guardian* remarks:—"In our own opinion the committee has not only incidentally done serious damage to the University, but it has done violence to a principle much more important than the one it has introduced. That principle is, that while there are many valid reasons why the amount spent by the State on educational institutions should be increased, there is only one valid reason for its ever being reduced—their inefficiency. It is right to penalise a college or a school because it does not come up to standard, but it is contrary to justice and to public policy to penalise one of which nothing but praise is uttered."

OXFORD.—A grant of 300*l.* having been made from the University chest to the professor of pathology for the provision of a lecturer and a demonstrator in his department, the professor has nominated Dr. E. W. Ainley Walker as lecturer in pathology.

SHEFFIELD.—Mr. Haldane visited the University on November 20, and inspected various departments and addressed a large gathering of the students, staff, and others, presided over by Sir Charles Eliot, the Vice-Chancellor. Mr. Haldane spoke of the developments of recent times which have brought universities into contact with industrial life. The closest connection of science and industry may be made to the lasting advantage of both, and without damage to either. It is becoming truer every day that no man can hope to control a great university who has not at his disposal resources which science alone can give. The laboratory and the professor have inspired

some of the greatest industrial movements of the time, and all indications are that that will continue to be so more and more. It is sometimes said that the only source of wealth is labour. This was true in old days, when science was little applied to industry, and there were capitalists and labourers and little else, but conditions have since then been changed. There is an abundance of labour, but also a greater abundance of capital. It is becoming apparent that labour undirected, labour without knowledge and without scientific ability to direct it, is incapable of serving the purpose of those who wish to develop the resources of nature. The real source of wealth is the direction of labour and capital to the right points of application. Knowledge is the source of wealth—scientific knowledge, business knowledge—the capacity of the trained man; and the men with that capacity, the men of brain and of science, are emerging more and more as those who have the power of controlling the resources of the earth, and labour and capital are becoming more and more instruments in their hands.

GIFTS and legacies to the funds of Yale University amounted to more than 100,000l. during the fiscal year recently completed. Gifts amounting to 70,000l. were received by the New York University during the past fiscal year. The value of this University's property is more than 1,000,000l.

PROF. BEDSON last June completed his twenty-fifth year as professor of chemistry at the Armstrong College, Newcastle-upon-Tyne. The event was the occasion of many congratulations and suitable presentations. In addition to the celebration arranged last summer, we notice from the report of the principal of the college that the council has "deemed it only fitting to mark the occasion, and its profound appreciation of Prof. Bedson's exceptional services to the college, by unanimously voting him a 'jubilee' vacation of six months, to take effect in the course of the coming year, together with a sum of 200l." We congratulate Prof. Bedson, and commend the course of action adopted by the Newcastle authorities to the notice of other college councils.

The fifth annual report of the Manchester Education Committee deals with the year 1906-7, and provides much information concerning the successful attempts made in the city to coordinate educational effort and to prevent overlapping and waste. Full particulars are given as to the work during the session of the Municipal School of Technology. There was for some reason a decrease of 164 in the total number of individual day and evening students enrolled, which, however, reached 5140. The total volume of work of the evening departments, computed in student hours, that is, by multiplying the number of students enrolled by the total number of hours of instruction, was 444,827 student hours, whilst the actual volume of work, namely, the total number of hours of instruction multiplied by the actual attendances, was 290,046, or 65 per cent. of the total volume of work.

THE inaugural address delivered by Prof. Willis G. Tucker at the opening of the present session of the Albany Medical College has been reprinted from the Albany Medical Annals of the present month. The address dealt with educational democracy, and in it Prof. Tucker indicated several directions in which, unless care is taken, danger may result to American higher education from the large private benefactions of recent years. Quoting from a speech of Chancellor MacCracken at New York University, Prof. Tucker urged that, as a result of the gifts of millions of dollars from great American financiers, the universities are in danger of being reckoned the purchased servants of a narrow caste. He went on to insist that in a country like the United States "higher education should be in no way dependent upon the variable and perhaps ill-directed impulses of individuals, however generous and philanthropic they may be." He maintained that it is the duty of the State to provide technical and higher education for the people, enumerated the reasons for his belief, and indicated some of the directions in which he thought the necessary funds might be raised.

THE report of the council of University College, Bristol, presented to the governors at their annual meeting on November 20, is a record of steady progress as regards number of students and results of original investigations. For a college with limited means and indifferent local support, the amount of research carried on is particularly noteworthy. A department in economic biology has been formed with the object of rendering assistance to those engaged in agriculture and kindred pursuits. By carrying out investigations and experiments, and by suggesting preventive or remedial measures where crops and fruit trees have been threatened or attacked by insect or other pests, it is hoped that the department will meet a real need. The committee of the Bristol Museum has consented to form collections illustrative of economic biology. Though the college is a centre of intellectual life and interest in the city of Bristol and neighbourhood, it derives only a meagre income of about 500l. a year from the sustentation fund. If this may be taken as an index of public support to higher education in the west of England, the prospects of a university do not seem very promising. It is hoped, however, that the King will visit the city to open the Avonmouth Docks next year, and that the promoters of the scheme for a university will be justified by that time in asking for a charter.

THE report for the session 1906-7 of the department of technology of the City and Guilds of London Institute has now been published. During the session, 3311 classes in technological subjects were registered at 376 centres, in 286 towns. These classes were attended by 46,048 students, being 1580 more than in 1905-6; 21,728 candidates were presented in technology from 439 centres in the United Kingdom, and of these 13,054 passed. By including the candidates from India and the colonies, and those for teachers' certificates in manual training and domestic economy, the total number of examinees was 23,572. These figures show an increase on those of any previous year. Members of the institute's staff for the examination, inspection, or organisation of classes visited ninety-two centres during the year. The report points out two main causes which impede progress in the technical instruction of artisans and prevent the results of the teaching from being as satisfactory as might be desired. They are, first, the difficulty of finding competent teachers, and, secondly, the unduly large proportion of artisan students who enter technical classes without the preliminary knowledge necessary to take full advantage of the instruction they receive. It is fully recognised in the report that the teaching of technology has improved greatly during the past decade, but it is noted that the examiners have still to direct attention repeatedly to the insufficient knowledge that candidates possess of the principles of the subjects, and to point out that the fluctuating quality of answers in different groups of papers indicates faulty teaching as the source. As regards the preliminary training of the students, it is desirable, the report says, that more encouragement should be given to the further attendance of pupils at a school in which provision is made for manual training, English, and practical science teaching, before commencing the distinctly technical part of their course of training.

SOCIETIES AND ACADEMIES.

LONDON.

Chemical Society, November 7.—Sir William Ramsay, K.C.B., F.R.S., president, in the chair.—Gaseous nitrogen trioxide: H. B. Baker and Mrs. Baker. Liquid nitrogen trioxide can be converted into the gaseous state if it is dried completely. The liquid is green at the ordinary temperature, but becomes blue below -2° . In liquid air it solidifies to a mass of dark blue crystals.—The atomic weight of tellurium: H. B. Baker and A. H. Bennett. During the last thirteen years the authors have investigated tellurium, and the possibility of its containing a second element, but so far all the evidence obtained points to the homogeneity of the element.—The isomerism of the double sulphites of sodium and potassium: M. H. Godby. No evidence of the existence of the two isomeric salts KO_2Na and NaO_2K could be obtained.—Studies

in the camphane series, part xxiv., camphoryldithiocarbamic acid and camphorylthiocarbimide: M. O. Forster and T. Jackson. Descriptions of both these compounds are given.—The vapour pressures of triethylamine, of 2:4:6-trimethylpyridine, and of their mixtures with water: R. T. Lattey. The total pressure curves obtained experimentally for these mixtures conform to the type expected theoretically. The partial pressure curves can be calculated by a form of the Duham-Margules equation.—Liquid triethylamine: R. T. Lattey. Evidence is brought forward to show that the amine is a unimolecular liquid.—Note on the constitution of homoeriodictyl: F. B. Power and F. Tutin. It is shown that in so far as the observations of Mossler (*Sitz. K. Acad. Wiss. Wien*, June) with regard to this compound are accurate, they can be explained by the formula previously suggested by the authors (*Trans. Chem. Soc.*, xci., 886).—The alkyl compounds of gold. Diethylauric bromide, preliminary note: W. J. Pope and C. S. Gibson. This colourless crystalline substance, the first alkyl compound of gold described, is obtained by the action of auric bromide on magnesium ethyl bromide in ether.—The interaction of methylene chloride and the sodium derivative of ethyl malonate. A correction: F. Tutin. The yellow sodium salt previously described (*ibid.*, xci., 1141) is the sodium derivative of ethyl dicarboxylglutaconate, formed by the action of chloroform present as an impurity in the methylene chloride.—Preparation of aliphatic nitro-compounds: P. C. Rây and P. Neogi. The nature and quantities of the nitrites and nitro-compounds obtained by interaction of various alkyl iodides with mercurous nitrite are given.—Some mercury derivatives of camphor: J. E. Marsh and R. de J. F. Struthers. A description of the compounds obtained by heating camphor with alkaline mercuric iodide.—Contributions to the chemistry of the terpenes, part ii.: G. G. Henderson. The addition product of chromyl chloride and limonene is described, as well as the decomposition products obtained from this.—The synthesis of acridines and phenonaphthacridines, tetra- and hexa-methylacridines, dimethylphenonaphthacridines, dixilylmethylene diamines: A. Senior and A. Compton.—The root and leaves of *Morinda longiflora*: M. Barrowcliff and F. Tutin. These materials are reputed in Sierra Leone to possess valuable medicinal properties, but the products obtained from them, viz. (a) hydroxymethoxymethyltraquinone, (b) morindanol, $C_{15}H_{14}O_6 \cdot OH$, m.p. 278, (c) a phytosterol, (d) hentricontane, (e) a mixture of lower fatty acids and citric acid, and (f) resins and other amorphous products, possess no pronounced physiological activity. A small amount of the alizarin monomethyl ether, which occurs in "Chay" root, was also obtained.—Ethyl α -cyano- γ -phenylacetacetate: A. R. Smith and J. F. Thorpe.—Aromatic amides and imides of camphoric acid: W. O. Wootton.—The melting point of *d*-phenylglucosazone: F. Tutin. The phenylsazones of sugars occurring naturally in a number of plants have been prepared, and found to melt at temperatures varying from 205° to 210°. On re-crystallisation from pyridine they melted at 215° to 218°, which is the melting point of *d*-phenylglucosazone, similarly re-crystallised from pyridine.—The interaction of cyanodihydroacryone, amyl nitrite, and sodium ethoxide: A. Lapworth and E. Wechsler.

Royal Anthropological Institute, November 5.—Prof. D. J. Cunningham, F.R.S., president, in the chair.—A new method of ascertaining the stature and making other measurements of the living person: Prof. D. J. Cunningham. The apparatus consists of a large bed of slate placed against a wall and divided into centimetre squares. The subject is placed against the slate, and by the aid of a carpenter's square the height and other measurements can be read off.—A series of so-called "grave stones" and other objects of a similar nature from the west of New South Wales: N. W. Thomas. The objects, most of which are apparently manufactured of a mixture of gypsum and sand, are in many cases marked with parallel grooves and signs resembling broad arrows. Some of them are long, banana-shaped objects with a cup-shaped hollow in the base. These are said to be found in sand-hills associated with implements and other remains of old camps. As to the meaning of these there is absolutely

no information. Others, which are shorter, thicker, and sometimes helmet-shaped, are certainly placed upon graves, but the precise object is uncertain.

Royal Astronomical Society, November 8.—Mr. Newall, president, in the chair.—Pogson's Observations of Variable Stars, edited by C. L. Brook and H. H. Turner: Prof. Turner.—Note on the ancient solar eclipses discussed by Mr. Cowell: A. C. D. Crommelin. The author had made an independent calculation of the six most important ancient eclipses, and obtained results practically identical with those of Mr. Cowell. Further reasons were given for supposing that the eclipse of —1062 was witnessed from Babylon itself, and a brief statement was given of the point at issue between Mr. Cowell and Prof. Newcomb and Mr. Nevill.—Disappearance of Saturn's ring system, October 3: R. T. A. Innes. The ring was easily seen with the 9-inch refractor of the Johannesburg Observatory at 4.45, in twilight, but became invisible by 10.30 the same evening, so the earth must have passed through the plane of the ring soon after invisibility.—The ultra-violet region in sun-spot spectra, and spectrum of comet d1907: J. Evershed. The papers were read by Dr. Michie Smith, who showed a series of sun-spot spectra taken at Kodaikānal Observatory, and also a photograph of the comet spectrum showing several lines extending into the tail, and a pair of very bright lines confined to the nucleus, which were identified with the lines of cyanogen.—Photograph of comet d1907 taken at the Royal Observatory, Greenwich: A. S. Eddington. The tail of the comet appeared to consist of a number of fine straight rays spreading from the nucleus.—Note on the permanency of some photovisual lenses: Dr. W. J. S. Lockyer. Six of these lenses, of apertures of 3 inches to 12 inches, have been in use at the Solar Physics Observatory, and in periods of from twenty-three to eighty-three months they have all developed curious markings on one or more of their inner surfaces. The markings appeared on the inner surfaces of one or both of the outside lenses, and not on the inner lens, as had been expected. A series of photographs was shown, the markings being crystalline formations, sometimes covering the entire lens. It was concluded that the formation was due to the absorption of water vapour by the glass, setting free its alkaline components to form carbonates, which are deposited as crystals. Further particulars were given in a note by Mr. Dennis Taylor, appended to Dr. Lockyer's paper.—Spectroscopic observations of cyanogen in the solar atmosphere and in interplanetary space: H. F. Newall. The author had found by the method of Cornu that cyanogen was present in the solar atmosphere, but it also appeared to exist in space, and the suggestion was made that the presence of cyanogen in comets, as shown by their spectra, might be due to the latter circumstance rather than to its existence in comets themselves.—A series of spectroheliograph photographs of solar facule and prominences taken at the Kodaikānal Observatory, India: Dr. Michie Smith.

Mathematical Society, November 14.—Prof. W. Burnside, president, in the chair.—Hyper-complex numbers: J. H. Maclagan Wedderburn. The object of the paper is to develop a treatment of hyper-complex number-systems by aid of the calculus introduced by Frobenius, and applied by him to the theory of groups.—The invariants of a binary quintic and the reality of its roots: Dr. H. F. Baker. It is usual to express the invariants of a quintic in terms of a set of four, which are connected by a syzygy. In the paper three rational functions of the four are introduced, each of them an invariant, and two of them absolute invariants, in terms of which each of the four, and any other invariant, can be expressed rationally, and the explicit expressions of the four original invariants in terms of the three new invariants are given. When the two new absolute invariants, denoted by X, Y , are regarded as coordinates of a point in a plane, the conditions that the quintic, with real coefficients, may have one, three, or five real roots are determined by the division of the plane into four regions by means of a certain quartic curve, corresponding to the vanishing of the discriminant, and an arc of a certain cubic curve which touches this quartic. The number of

real roots is determined without any ambiguity by the situation of (X, Y), whether it is in one of these regions or on a bounding line.—The application of quaternions to the problem of the infinitesimal deformation of a surface: **J. E. Campbell**. Weingarten's characteristic function in this problem can be interpreted kinematically as the normal component of the rotation, which an element of surface undergoes in the course of the deformation. The direct application of the method of moving axes, to obtain the characteristic equation, can be simplified very much by the use of quaternions.—Addendum to a paper on the inversion of a repeated infinite integral: **T. J. P. A. Bromwich**.—Generalisation of a theorem in the theory of divergent series: **G. H. Hardy**.—Uniform and non-uniform convergence and divergence of a series, and the distinction between right and left: **Dr. W. H. Young**.—Nodal cubics through eight given points: **J. E. Wright**.—A transformation of hypergeometric series: **Dr. E. W. Barnes**.—A transformation of a certain hypergeometric series: **Prof. M. J. M. Hill**.—A general theorem on integral functions of order less than one-half: **J. E. Littlewood**.

PARIS.

Academy of Sciences, November 11.—**M. A. Chauveau** in the chair.—A new mineral species, arising from the Athenian plumbiferous scoria of Laurium: **A. Lacroix** and **A. de Schulten**. This is one of a series of minerals arising from the action of sea water upon scoria rich in metallic lead and galena. Its composition corresponds to the formula $Pb_2(AsO_4)_{2.5}PbCl_2$. The crystallographic measurements are given, and the hardness (3.5) and density (7.1) measured. The name *georgiaditesite* is proposed for the mineral.—The influence of feeding on the course of experimental tuberculosis: **MM. Lannelongue, Achard, and Gaillard**. In sixty strictly comparative experiments, in three classes of diet in which fat, carbohydrate, and nitrogenous food respectively predominated, the animals with the fatty food died in forty days; with sugar, eighty-seven days; and with gluten, 371 days. This confirms the result of the authors' early work, clearly demonstrating the superiority of a strongly nitrogenous diet in fighting tuberculosis.—Continued algebraic fractions: **Edmond Maillet**.—The periodic solutions of the equation

$$\Delta u + \lambda u(x, y, z) = 0;$$

A. Myller.—The method of x-ray photography of MM. A. and L. Lumière; **Adrien Guéhard**. A discussion of the phenomena attending the reversal of the image in this process.—The measurement of the anomalous dispersion in crystals at different temperatures, and on some theoretical consequences: **Jean Becquerel**. It is shown that the large increase of intensity observed for the majority of the absorption bands of tysonite when the crystal is plunged into liquid air is not entirely due to the contraction of the bands, but is also caused by an increase in the total energy absorbed, corresponding to the increase in the dielectric coefficient of the electrons.—A comparison of the effects of the X-rays and radium upon the plant cell. Value of the unit M in plant physiology: **H. Guilleminot**.—The action of radium bromide on precious stones of the alumina family: **F. Bordas**. A modification of the method described in a previous paper. Colourless corundum has been transformed into topaz, the depth of colour of natural topazes increased, and a similar effect produced with faintly coloured rubies. Colourless fused alumina, submitted to the action of radium bromide, became first rose-coloured and then reddish yellow. Since this action takes place equally well at -200° , the conclusion is drawn that the phenomenon of coloration is not due to oxidation.—The diastatic function of colloids: **J. Duclaux**. From a quantitative study of the catalysis of hydrogen peroxide solutions by colloidal solutions of ferric hydrate, the author concludes that the hydrolysed part of the salt does not intervene in the catalysis, and that it is the undecomposed ferric chloride which effects the change.—The action of gold on the dioxide of sodium and barium: **Fernand Meyer**. Precipitated gold reacts with fused sodium dioxide, yielding sodium aurate, and barium dioxide attacks gold similarly, although the reaction is less complete. From these substances auric acid can be prepared by the action of sulphuric acid. Auric acid, dried in a vacuum in the dark, has the composition $Au_2O_3 \cdot 3H_2O$ or

$Au(OH)_3$. The preparation of the pure aurates of sodium, potassium, barium, strontium, and calcium from this acid is described. These aurates are decomposed by heat or light, the insoluble residue being Au_2O_3 , and not gold as supposed by Fremy.—The preparation of some iodides *in vacuo*: **Marcel Guichard**. The preparation of the anhydrous iodides of iron, nickel, silicon, and aluminium is described.—The action of amorphous arsenic on the alkyl halides: **V. Auger**. Amorphous arsenic, prepared by the reduction of a hydrochloric acid solution of arsenic anhydride with stannous chloride or a hypophosphite, is very active. It reacts with methyl iodide at the ordinary temperature, and at higher temperatures in sealed tubes with CCl_4 , $CHCl_3$, C_2H_5Br , C_2H_5I , CHI_3 , and various alkyl iodides.—The iodohydrins and alkylodiodohydrins derived from styrolene: **Marc Tiffeneau**.—The action of urea, thiourea, urethane, and some amides on xanthidrol: **R. Fosse**.—The application of the Hoffmann reaction to sparteine: **Charles Moureu** and **Amand Valeur**.—The estimation of fat in skimmed milk: **R. Lozé**. Three litres of the milk are mixed with ammonia and caustic soda, and the whole passed through a centrifugal separator.—The coloration of certain precious stones under radio-active influences: **Daniel Berthelot**.—The products of the volcano Monte Ferru, Sardinia: **M. Deprat**.—The influence of high altitude on the loss of water by the organism: **H. Guillemard** and **Aug. Moog**. The effect of high altitude is not to increase the rate of loss of moisture from the body, but, on the contrary, to reduce it. The experiments leading to this conclusion were conducted at Paris, Chamonix (1050 metres), Grands-Mulets (3050 metres), and the summit of Mt. Blanc (4810 metres).—The development of the energy of the voice: **M. Marage**. A description, with diagrams, of a set of exercises to increase the volume of air expelled from the lungs.—The visibility of night signals at sea: **André Broca** and **M. Polack**. The practical conclusions drawn from this investigation are as follows. If a signal of doubtful colour is better seen by direct vision than by indirect vision, it is red. In the contrary case the light is blue or colourless.—A new method of determining the accelerating power of neutral potassium and sodium salts on the coagulation of milk by vegetable ferments: **C. Corber**.—The mitosis of cells containing *Bacillus cuneolus*: **L. Mercier**.—The experimental study of medicines stimulating the movement of the stomach by the aid of fluoroscopy: **G. Carrière**.—A new Myxomycetum, an endoparasite of insects: **Louis Léger**.

November 18.—**M. Henri Becquerel** in the chair.—The transit of Mercury across the sun of November 13 and 14, 1907. Observations made at the Observatory of Nice: **M. Eassot**.—Observations of the Daniel comet, 1907d, and a general plan of organisation for the complete physical study of comets: **H. Deslandres**.—The transit of Mercury of November 14, 1907, at the Observatory of Lyons: **Ch. André**.—Observations made at the Observatory of Toulouse of the transit of Mercury of November 13-14: **B. Baillaud**.—Similar observations made at the Observatory of Marseilles: **E. Stephan**.—Similar observations from the Observatory of Bordeaux: **L. Picart** and **E. Esclangon**.—Similar observations from the Observatory of Bourges: **Th. Moreux**.—The occultation of the satellites of Jupiter: **G. Le Cadet**.—The observation of the transit of Mercury across the sun, November 13-14, 1907: **A. de la Baume Pluvinel**.—Remarks on the relation between the solar activity and magnetic perturbations: **MM. Cirera** and **Baicelli**.—The transit of Mercury, November 13-14, at the Observatory of Besançon: **MM. Bruck, Chofardet, and Pernet**.—The correction of the astigmatism of doubly refracting prisms: **C. Tissot** and **Félix Pellin**. The astigmatism can be corrected by the use of an appropriate cylindrical lens.—The propagation of telephone currents on subterranean lines: **Henri Abraham** and **M. Devaux-Charbonnel**.—The magnetic double refraction of organic liquids: **A. Cotton**, **H. Mouton**, and **P. Weiss**.—The multiplicity of sounds emitted by tuning forks: **G. Sizès** and **G. Massol**.—The action of the Röntgen rays upon crystallised alumina: **F. Bordas**. The author has described in previous papers the alteration of colour produced in various forms of crystallised alumina by the action of the rays from radium

bromide. From the fact that the radium salt acts from the inside of a glass tube, the α rays are excluded from the action. Since similar colouring effects are now shown to be produced by the Röntgen rays, it is probable that the effects observed are due to the γ rays.—The presence of β -methoxycinnamic aldehyde in essence of estragon, and on some derivatives of estragol: Maurice **Daufre**. The aldehyde was isolated from the essence by repeated fractional distillation under reduced pressure, and by its reactions and analysis identified with β -methoxycinnamic aldehyde. Since, however, the constants did not agree with those of the same aldehyde, as described by Scholtz and Wiedemann, a synthetic sample was prepared, and found to be identical with that from the essence.—The artificial reproduction of heavy spar, celestine, and anglesite, and on isomorphous mixtures of these substances: Paul **Gaubert**. The method used is the re-crystallisation of the precipitated sulphate from sulphuric acid at, or slightly below, its boiling point.—The influence of the concentration of sugar solutions on the development of the spikes of *Ulex europaeus*: Marin **Moliard**.—Floral anomalies due to mechanical action: M. **Ducamp**.—The use of heat for the treatment of coffee plants against the attacks of the Indian borer (*Ylotrechus quadrupes*): Louis **Boutan**. To have any practical results it is necessary that all parts of the plant affected should be raised to a temperature of 50° C. This cannot be done by the direct action of a burner, and the author has designed a special stove for this purpose.—The possibility of establishing the diagnosis of death by radiography: Charles **Vaillant**. In a radiograph of a living person the stomach and intestines are not visible. Owing to their stationary condition after death, and possibly owing also to the development of gases which reinforce the action of the rays, these organs are clearly shown immediately after death in the radiograph, and the clearness increases with lapse of time after death.—The study of the epileptic sero-appendices: R. **Robinson**.—The north Pyrenees and pre-Pyrenees sheets of *charriage* to the east of the Neste: Léon **Bertrand**.—An ancient bed of the Pliocene Loire: E. **Chaput**.—The relation between the radio-activity of subterranean waters and their hydrology: F. **Dienert** and E. **Bouquet**.

DIARY OF SOCIETIES.

THURSDAY, NOVEMBER 28.

INSTITUTION OF ELECTRICAL ENGINEERS, at 8.—The Development of Turbo-Generators: Dr. Robert Pohl.

FRIDAY, NOVEMBER 29.

SOCIETY OF ARTS, at 8.—The Hygiene of Work in Compressed Air. (Diving, Caisson Work, Sub-aqueous Tunneling, &c.): Dr. J. S. Haldane, F.R.S.

SATURDAY, NOVEMBER 30.

ESSEX FIELD CLUB (Essex Museum of Natural History, Stratford), at 6 p.m.—Notes on an Ancient Human Skeleton found at Foxearth, Essex: I. M. Wood.—A History of the Mineral Waters and Mineral Springs of Essex: Miller Christy and (Miss) May May Thresh.

MONDAY, DECEMBER 2.

SOCIETY OF ARTS, at 8.—The Theory of the Microscope: Conrad Beck.

ASTROLOGICAL SOCIETY, at 8.—Purpose: Prof. Robert Latta.

SOCIETY OF CHEMICAL INDUSTRY, at 8.—The Estimation of Naphthalene in Coal Gas and Spent Oxide of Iron: C. J. Dickenson-Gair.—Note on the Influence of Formal on the Properties of *Fantunia elastica*: Dr. P. Schidrowitz and F. Kaye.—The Polarimetric Determination of Sucrose: Dr. F. Watts and H. A. Tennyson.—Niam Fat: Dr. J. M. Perkin.

TUESDAY, DECEMBER 3.

INSTITUTION OF CIVIL ENGINEERS, at 8.—Experiments on Wind Pressure: Dr. T. E. Stanton.

WEDNESDAY, DECEMBER 4.

GEOLOGICAL SOCIETY, at 8.—The Faunal Succession in the Carboniferous Limestone (Upper Avonian) of the Midland Area (North Derbyshire and North Staffordshire): T. F. Sibly.—Brachiopod Homomorphism: *Spirifer elaber*: S. S. Buckman.

ENTOMOLOGICAL SOCIETY, at 8.—Notes and Descriptions of Pterophoridae and Orneoidae: E. Meyrick, F.R.S.

SOCIETY OF PUBLIC ANALYSTS, at 8.—The Volumetric Determination of Reducing Sugars: Part I.—The Determination of Invert Sugar in Presence of Varying Amounts of Cane Sugar: A. R. Ling and T. Rendle.—The Quantitative Separation of Barium from Strontium: Miss Zella Kahan.—(1) The Action of Dimethyl Sulphate (Valenta's Reagent) upon Oils of the Aromatic and Aliphatic Series. (2) Titration with Permanganate in Presence of Hydrochloric Acid: T. W. Harrison and Dr. F. M. Perkin.—Routine Methods for the Bacteriological Examination of Water: A. R. Tankard.

THURSDAY, DECEMBER 5.

ROYAL SOCIETY, at 9.—*Proceedings*: Reciprocal Inervation of Antagonistic Muscles. Eleventh Note. Further Observations on Excessive Induction: Prof. C. S. Sherrington, F.R.S.—On the Distribution of the Different

Arteries supplying the Human Brain: Dr. C. E. Beavor.—Localisation of Function in the Lemna's Brain: Dr. F. W. Mott, F.R.S., and Prof. W. D. Halliburton, F.R.S.—On the Supposed Extracellular Photosynthesis of Carbon Dioxide with Chlorophyll: Prof. A. J. Ewart.—The Influence of Increased Barometric Pressure on Man, No. 4, The Relation of Age and Body Weight to Decompression Effects: L. Hill, F.R.S., and M. G. Greenwood, jun.—On the Present Distribution and Origin of the Calcareous Concretions in Coal Seams known as "Coal Balls": Miss Stotes and D. M. S. Watson.—On the Structure of *Stigmaria scutellata*, Bronn., and other Equisetarian Stems in Comparison with Those of other Palaeozoic Lycopsids: R. A. Newell Archer and H. H. Thomas.

CHEMICAL SOCIETY, at 8.30.—The Affinity Constants of Bases as Determined by Methyl Orange. Preliminary Communication: V. H. Veley.—The Velocity of Reduction of the Oxides of Lead, Cadmium, and Bismuth by Carbon Monoxide, and the Existence of the Suboxides of these Metals: F. J. Brisele.—The Relation between Unsaturation and Optical Activity, Part I.—The Methyl and Boryl Esters of β -Phenylpropionic, Cinnamic, and Phenylpropionic Acids: T. P. Hilditch.—The Constituents of the Essential Oil of Nutmeg: F. B. Power and A. H. Salway.—Methyl Ethers of some Hydroxy-antraquinones: A. G. Perkin.—The Colouring Matters of the Stilbene Group, Part iv., the Action of Caustic Alkalies upon Parani rotulone and its Derivatives: A. G. Green, A. H. Davies, and R. S. Horsfall.—The Replacement of Alkyl Radicals by Methyl in Substituted Ammonium Compounds: H. O. Jones and J. R. Hill.

INSTITUTION OF MECHANICAL ENGINEERS, at 8.—Automatic Cab-signalling of Locomotives: J. Figg.

CIVIL AND MECHANICAL ENGINEERS' SOCIETY, at 8.—Retaining Walls: A. T. Walmsley.

LINEAR SOCIETY, at 8.—Report on Alcyonaria of the Sudanese Red Sea: Prof. J. Arthur Thomson.—Report on the Crinoidae of the Sudanese Red Sea: H. C. Chadwick.—Notes on some Marine Algae from the Red Sea: Prof. R. J. Harvey Gibson.—Exhibitions.—Specimens of *Spartina Townsendii*, as illustrating its Distribution in Britain: Dr. Otto Stapf.—Laminar slides showing Stages of Soil-denudation consequent on the Removal of Forests: A. P. Young.

CONTENTS.

	PAGE
The Vertebrate Nervous System. By Dr. W. Page May.	73
Electric Power and Traction. By L. C.	74
School Chemistry and Practical Organic Chemistry. By J. B. C.	74
Our Book Shelf:—	
Velenovsky: "Vergleichende Morphologie der Pflanzen."—J. B. F.	76
van Earen: "De Vormen der Aardkorst: Inleiding tot de Studie der Physiographie"	76
North: "Nests and Eggs of Birds found Breeding in Australia and Tasmania"	76
Smalian: "Grundzüge der Tierkunde für höhere Lehranstalten."—R. L.	76
Perkin: "Les Précis des Caractères génériques des Insectes, disposés dans un Ordre naturel par le Citoyen Latreille"	77
Perkin: "The Metric and British Systems of Weights, Measures and Coinage"	77
James: "The Story of Scraggles (A Sparrow)"	77
Letters to the Editor:—	
Specific Stability and Mutation.—Sir W. T. Thielton Dyer, K.C.M.G., F.R.S.	77
The Winding of Rivers in Plains.—Sir Oliver Lodge, F.R.S.; R. C. Slater.	79
The Occurrence of Copper and Lithium in Radiation-bearing Minerals.—Prof. Herbert N. McCoy.	79
A Convenient Formula in Thermodynamics.—Harvey N. Davis.	80
A Miocene Wasp.—Prof. T. D. A. Cockerell.	80
The Eggs of the Platypus.—The Reviewer.	80
Literature relating to Australian Aborigines.—Dr. A. W. Howitt; K. H. Mathews.	80
Notes on Ancient British Monuments. II. (Illustrated.) By Sir Norman Lockyer, K.C.B., F.R.S.	82
The Preservation of Eggs	84
Notes	85
Our Astronomical Column:—	
Astronomical Occurrences in December	89
Saturn's Rings	90
Photographs of Jupiter	90
Final Designations of recently discovered Variables	90
A Large Eruptive Prominence	90
Surveys of Nebulae	90
New Geological Survey Maps and Memoirs. (Illustrated.)	90
Recent Publications of the U.S. Museum.—By R. L. University and Educational Intelligence Societies and Academies	93
Diary of Societies	96

THURSDAY, DECEMBER 5, 1907.

A TEXT-BOOK OF PLANT PHYSIOLOGY.

Lectures on Plant Physiology. By Prof. Ludwig Jost. Authorised English translation by Prof. Harvey Gibson. Pp. xiv + 564; illustrated. (Oxford: Clarendon Press, 1907.) Price 21s. net.

PROF. JOST'S lectures appeared in German in 1904, and were soon appreciatively reviewed in the columns of NATURE. It was twenty years since a book had appeared so admirably adapted for the use of students of the physiology of plants, and an English translation was eagerly awaited by teachers of the subject. Now that it is to hand we find that it contains several hundred mistranslations; quotation of a short series of these will show how greatly the English rendering lacks accuracy. On p. 44, and elsewhere, "succulent plants" become "oily plants." On p. 114, by mistranslation, all Brown and Morris's work on the carbohydrates of foliage leaves is transferred to another investigator.

On p. 128, the fact that in Engelmann's micro-spectral investigations by the bacterial method the assimilating cells are lighted from *below* is ignored, and the significance of a table of data is destroyed in translation by the illuminated side being styled the *upper* side. On p. 229, Pflüger's hypothesis that respiration always involves direct oxidation of the actual substance of the protoplasm itself is stated in one sentence; and yet the next says that if it could be shown that nitro-bacteria only oxidise ammonia in their respiration, this theory would be *established*. The German says the exact opposite—that the theory would thus be *disproved*. On p. 230 we find the statement that small doses of sugar and organic food *accelerate* the development of nitrifying organisms, whereas the *inhibiting* action of such "nutriments" upon these special organisms is one of the outstanding wonders of protoplasmic mutability. On p. 265 it is stated that certain "cells exhibited growth at their ends" instead of "the cell-growth came to an end."

On p. 278, dealing with the forms of the plant-body, we read:—

"There are quite a number of plants which form only one axis, on which no lateral members save leaves are produced. In a second series may be placed the numerous coniferæ which *develop lateral branches only*. The majority of higher plants, however, form both lateral buds and leaves."

Consultation of the German shows that the three contrasted series really are:—main axes bearing (1) leaves only; (2) leaves and occasional lateral branches; and (3) leaves and as many lateral buds as there are leaves. On p. 334 the process of "budding" is described under the title of "grafting," and that of "grafting" under "budding." On p. 335 "leaf-trace" is translated by "leaf-spur," while on p. 331 it appears as "leaf-base." On p. 339, discussing the range of adaptation to habitat, we read:—

"Although amphibious plants can live in water as well as on land, there is usually in the long run a certain minimum and a certain maximum degree of

dampness which may not be exceeded; in other words, amphibious plants cannot on the one hand become aquatic nor on the other xerophytes."

It is hard for the English student to divine that what the author says is that amphibious plants on land generally need a fair amount of moisture; they cannot range from an aquatic habit all the way to a xerophytic habit.

On p. 400 one sentence says that the raising of the temperature of the arum spadix above that of its environment by respiration is scarcely appreciable during *intra-molecular* respiration, while the next says that the organ is hotter in *intra-molecular* respiration than in normal respiration. On p. 407 we find that Askenasy observed certain capillary phenomena on wetting "deposits on cover-glasses"; this should be on wetting "a pile of cover-glasses": on the same page it is stated that the possibility of gelatine having, in its substance, microscopically fine capillary spaces containing air is disproved by its "impermeability to air"; the German says by its "transparency."

On p. 543 there occurs the following incomprehensibility as a rendering of the Weber-Fechner law as exemplified in human perception of differences of weight:—

"A weight of 1 mg. must be increased one-third, a weight of 10 mg. must be increased ten-thirds before we can appreciate a difference between them."

In some ten or more places the expression "presentation time," in reference to a stimulus, is rendered by "latent period" to the complete confounding of the sense.

Finally, the headings of the chapters are not always correctly rendered. Chapter xxxii. deals with movements due to "Kohäsion des Füllwassers," which means the cohesion of the water-contents filling the cells. Yet in the title and throughout the chapter *Füllwasser* is translated by "imbibition-water," which is quite a different phenomenon.

To these faults of commission are yet to be added those of omission. In the bibliographies at the ends of the chapters all the titles of English works still remain in the German language. Is the student to take no pride in his heritage in the work of Darwin, Hales, Knight, and others? Further, all the many works translated from the German by the Oxford Press are quoted in German without reference to the fact that there are English translations available for students. Even the references to Pfeffer's "Physiology" are all to the pages and volumes of the German edition.

When provided with a list of essential corrections of the text, this text-book will be a very valuable addition to the distinguished series of German handbooks prepared for English students by the Clarendon Press.

In conclusion we may express our high esteem for Prof. Jost's lectures. The exposition is extremely lucid, and just what is needed for students taking up the advanced study of physiology. The author pays well-merited tribute to Pfeffer's classical handbook.

with which the present work does not compete in fulness of treatment, the different parts of the subject being elaborated only so far as will be assimilable by students. In dealing with matters that are still unsettled, the author shows considerable judgment, but he has perhaps a tendency to over-refine the division and classification of phenomena, as, for example, in discussing symbiosis, parasitism, and fermentation.

Short passages, in square brackets, have been interpolated by the author here and there in this issue with the intention of bringing the text up-to-date. Special details may be thus indicated, but broader advances can hardly be dealt with in this way; nevertheless, the work is the most modern exposition of the physiology of plants available in any language.

F. F. B.

LIQUID AND GASEOUS FUELS.

Liquid and Gaseous Fuels, and the Part They Play in Modern Power Production. By Prof. V. B. Lewes. Pp. xiv+334. (London: A. Constable and Co., Ltd., 1907.) Price 6s. net.

WITH the multiplication of institutions where the teaching of applied science is made a leading feature, there has sprung into existence quite a number of text-books which specially appeal to students of this kind. Some of these works are both interesting and useful, but it must be confessed that they one and all seem rather to appeal to the type of mind which is disinclined to attack any really difficult problems. Text-books such as were published twenty years ago, by men such as Rankin and Cotterill, which endeavoured to get at the scientific principles underlying the applications of applied science, seem, with very few exceptions, to have gone out of date and to have become replaced with more interesting and better written books, dealing more or less with the descriptive part of the subject which they treat. Prof. Lewes very modestly states that he does not wish to produce a work that shall, to any extent, enter into detail, and his book is professedly a sketch of the subject. This is to be regretted, as we feel sure that a chemist of such eminence could have produced a work which would have been of great value, not only to the students, but to that large class of engineers who wish to get information on some of the difficult points in connection with both liquid and gaseous fuels.

The chapters on combustion deal wholly with burning at ordinary pressures, and are both clear and accurate. It is unfortunate that the scope of the work does not allow Prof. Lewes to allude to some of the phenomena of burning under pressure, a subject of enormous importance, and one of which very little is known.

The description of the various forms of solid fuels, together with the determination of their calorimetric values, is well done, but we should have expected to find something said about the discrepancy which almost always occurs when using the Junker calorimeter with gas and air, which has not been completely saturated, as this affects the quantity of condensed

water that has to be measured in order to obtain the lower value.

There is a great deal of useful information on the subject of liquid fuels; the arrangement of the hydrocarbons contained in these fuels is very well brought out, and no student can read through this chapter without acquiring a good idea of the various forms of liquid fuels derived from a common base.

The manufacture of coal-gas is, of course, of very considerable interest. There is nothing very novel, nor, should we say, of much service to the average student, unless, indeed, he is proposing to become a gas engineer.

There is an excellent description of the various methods of making water-gas, which at one time it was anticipated would play a very considerable part in the application of cheap gas for both heating and power purposes, and is very largely used for certain work. The large percentage of carbon monoxide which it contains has caused it to be looked upon with suspicion, except for the purpose of carburetted water-gas for use in coal-gas mains, and it is probable that very little water-gas is used for any other purpose, although, probably, this gas would be very much more used if it were possible to obtain a reduction in the standard now insisted upon as regards the illuminating value of gas.

The description of the producers proper is not so full as the merits of these producers would entitle them to. The suction producer is alluded to, but not described to any great length, and in considering the bituminous producers Prof. Lewes appears to consider that it is essential in bituminous plants to recover the ammonia. This is, of course, a mistake. There are a large number of bituminous plants running which do not recover the ammonia, and which are perfectly satisfactory. Indeed, it is doubtful whether in the method of using excess steam in order to prevent the destruction of ammonia the value of the bituminous plant is not brought down, as a much better gas can be made when the steam is cut down to the lowest amount which can be used to prevent clinkering.

The last chapter, which deals with the fuel of the future, is certainly the most interesting of the whole work, and it points out very clearly that when the existing supplies of fuel become limited, we shall have to fall back upon alcohol, produced from vegetation of some sort or another, which may be made almost inexhaustible. There is no doubt that this is quite correct, and it is very much to be regretted that at present no experiments on alcohol on any scale can be made, owing to the restrictions which our fiscal conditions impose, and we presume that owing to this, the work will be carried out in some other country where the Government is more sympathetic towards scientific research.

There is one point which Prof. Lewes appears to have overlooked. He considers that the alcohol will be either manufactured from potato starch or sawdust. There seems no reason to doubt that when the question becomes urgent some highly-specialised plant will have been brought into existence for the sole

purpose of absorbing the maximum amount of carbon dioxide from the air, and in this manner it may be possible enormously to increase the amount of carbon which a given area of land will pick up. This may sound fanciful, but the wonderful improvements which hybridisation has effected in the past make it quite possible that in the future still greater improvements may be looked for.

A PRACTICAL HANDBOOK ON RUBBER.

Rubber Cultivation in the British Empire. By Herbert Wright. Pp. vi+100. (London: MacLaren and Sons, 1907.) Price 2s. 6d.

THIS is one of the most interesting and useful little books yet published on rubber cultivation, and should be in the hands of every planter. It is a reprint of a lecture delivered before the Society of Arts. The book is not only of great value to those interested in plantation rubber, but also to those interested in the development of wild rubber. Mr. Herbert Wright, who was at one time controller of the Government experimental station in Ceylon, is now the editor of the *India Rubber Journal*. He is also the author of one of our best standard works on rubber, viz. "Hevea Brasiliensis," which is a scientific treatise on the botany of rubber. The present publication is more in the form of a useful and practical handbook, and deals with the great potentialities of the rubber industry, and its importance from "the producer's standpoint, especially in British possessions."

The gradually increasing demand for raw rubber, and the remunerative prices obtained, have produced enormous developments in the past few years on Eastern plantations. At the present the most important centre for rubber collection is tropical America, which supplies about 60 per cent. of the world's output. Africa comes next with 30 per cent. to 35 per cent., but tropical Asia last year only contributed 3 per cent. Borneo, New Guinea, Fiji, New Caledonia, and the Seychelles are also commencing to develop a strong interest in rubber-producing plants.

"It may be safely stated," writes Mr. Wright, "that to-day there are no less than 14,000,000. of English money represented as paid up capital in companies directly or indirectly concerned with rubber growing. Furthermore, it may be estimated that approximately 30,000,000. worth of rubber may be consumed during the present year."

The natural order which supplies the greater part of the world's rubber is the Euphorbiaceae, the most valuable species being the Hevea, which produces the well-known Para rubber which has been planted so extensively in Ceylon, Federated Malay States, Straits Settlements, and Sumatra.

Mr. Wright speaks with considerable authority and experience on plantation Para rubber, and he thinks that it will sooner or later obtain a prominent, if not the commanding, position as a source of future rubber; but this will not be for many years, for its speaking of wild rubber he says:—

"Should the supply from wild sources become scarce—an improbable occurrence—it would be impossible for the plantations to supply the balance for many

years to come, as the producing capacity of the land now alienated for rubber in the East will only be in 1912 or 1913 some 12,500 to 25,000 tons per year. The rubber manufacturers have hitherto been dependent, almost entirely, on wild rubber; and it seems illogical to suggest that the rubber forests on which so much new capital and enterprise have been recently expended, and in which prominent scientific and business men are concerned, will be unable to satisfy the increased demand expected in the next few years. It may confidently be regarded as the principal source of rubber for the next half score of years, for the simple reason that plantations in the proper sense do not exist to produce what will be required."

At the end of the lecture there is an instructive discussion, in which Lieut.-Col. Prain, Mr. Gray, Mr. Fritz Zorn, and Mr. S. Figgis took part.

L. C. B.

OUR BOOK SHELF.

School Hygiene; a Handbook for Teachers of all Grades, School Managers, &c. By Herbert Jones. Pp. x+151. Dent's Mathematical and Scientific Text-books for Schools. (London: Dent and Co., 1907.) Price 2s.

THIS is one of the many books that the great movement towards school hygiene has thrown up. The book, or rather booklet, contains practically nothing that is new, but the selection of topics is done with judgment and care; every main subject of environmental hygiene is touched on with sufficient fulness to meet the needs of immediate practice or to provoke to further reading, and the illustrations are profuse and good. The author has succeeded in treating "the subject as simply as possible." The work of Dr. Kerr at the London County Council is largely drawn upon. As in Dr. Newsholme's "School Hygiene," the book is allocated half to the school and half to the scholar. In criticism, it may be said that rather much space is given to matters, e.g. site, building construction, and sanitary appliances, &c., that the teacher cannot alter or affect, and rather little space to what he can affect. But with this qualification the booklet forms a good introduction to the subject. The writing is well adapted to the intended readers.

Regeneration and Transplantation. By Prof. E. Korschelt. Pp. 286; 144 figures. (Jena: G. Fischer, 1907.) Price 7 marks.

OF recent years there has been much experimenting and not a little theorising regarding regeneration and grafting. The results of the experiments have sometimes been very remarkable and full of theoretical suggestiveness, and they are now so numerous that a general survey of their import is very welcome. We have already a volume on regeneration by Prof. T. H. Morgan which has been of great service; we have now an analogous volume by Prof. Korschelt. He traces the phenomena of regeneration through the world of organisms, in unicellulars and multicellulars, in plants and in animals, in young forms and full-grown forms, showing the varied distribution of the regenerative capacity and its varied expressions, and always returning to the central question, How has it come about, and by what precise processes does it come about, that a lost part is re-grown and the intactness of the creature restored? Special sections of the book are devoted to a discussion of such subjects as the following:—autotomy, often-repeated regeneration, restitutions and regulations, heteromorphosis, atavism in regeneration, imperfect and superfluous regeneration, the relation of the nervous system to

regeneration, the relation of regeneration to nutrition, to reproduction, to age, and to environmental conditions. The author's exposition is lucid, and there is an illustration on every second page. In the second part of the book we find an account of grafting or transplantation in plants and in animals, with strange figures of grafted polyps and worms, pupæ and tadpoles, frogs and newts—an altogether quaint assemblage. At the end of the book there is an exhaustive bibliography, certainly amazing in its dimensions, very usefully subdivided into sections relating to different aspects of the subject. As to the general theory of regeneration, Prof. Korschelt seems to incline to a compromise between the views of Weismann and Morgan, admitting that there is a great deal to be said on both sides. He seems—for he is anything but dogmatic—to believe that the regenerative capacity is a primary quality of living matter, which, along certain lines of evolution, has been accentuated and specialised by natural selection. Thus the regenerative capacity is, in general, a primary quality, but in particular cases an adaptive character.

Organische Zweckmässigkeit, Entwicklung und Vererbung von Standpunkte der Physiologie. By Dr. Paul Jensen. Pp. xiii+251. (Jena: Gustav Fischer, 1907.) Price 5 marks.

PROF. JENSEN has produced a book which attempts to deal in a philosophical manner with some of the most difficult problems that confront the biologist. The reader will perhaps be inclined to deprecate an attitude of "cock-sureness" that rather pervades the whole, but he will at the same time recognise that in many places the author is stimulating and suggestive.

A great part of the whole volume is devoted to the examination of the various explanations that have been put forward to account for adaptation in the organic world, as well as of those which have attempted to deal with the meaning and the method of evolution.

After a somewhat lengthy discussion of these topics, the author puts forward the analogies shown by various cosmic mechanisms to assume positions of relative or absolute stability, and he regards them as useful in throwing light on the problems of evolution. The whole of the constructive part of the book strikes us as very speculative, and though of undoubted interest, it may be doubted whether the point of view as advocated by Jensen will find much sympathy amongst working biologists. The title of the work indicates that it is written from the standpoint of physiology, but we have searched its pages in vain to find any serious physiology, as ordinarily understood, discussed in it at all. There is much philosophy of a sort, and much acute destructive criticism of many ideas and notions that are widely current. But it does not appear that in grappling with the problems he has set himself to face and to solve, the author has expressed himself so clearly as did Herbert Spencer many years ago. There is much in the work before us that recalls the "Principles of Biology," though there is a great difference between the lucid expression of Herbert Spencer and that of our author. The following passage, relating to the causes of extinction of species and genera in the past, will furnish a fair sample of the method of treatment:—"According to our theory of development, a natural extinction of species is to be anticipated as the expression of a general law. Organisms that are dying out in this way fall into the same category as those systems which, after enduring through a long period in a stationary condition, pass finally, as the result of slowly advancing changes, into a relatively stable state (death); a destiny that . . . in time will overtake many existing organisms, in spite of the 'rejuvenating' effects of amphimixis" (p. 237).

J. B. F.

LETTERS TO THE EDITOR.

[The Editor does not hold himself responsible for opinions expressed by his correspondents. Neither can he undertake to return, or to correspond with the writers of, rejected manuscripts intended for this or any other part of NATURE. No notice is taken of anonymous communications.]

The Windings of Rivers.

At the meeting of the British Association at Edinburgh in 1892 I read a paper on the subject of the winding of rivers before the geographical section. It was illustrated by a large number of diagrams, but, as these could not be included in the report of the meeting, only the title of the paper appeared. It may not be out of place to give a short account of it, as the subject is now attracting some attention.

In Fig. 1 the courses of three streams are shown. These are distinguished by the letters A, B, C, without indication of their identity or of the scale on which they are drawn. If anyone were to try to select the one which represents the largest or the smallest of these streams he might do so correctly, but he would not be surprised if he were told that he had guessed wrongly, for it could only be a guess. The length of each tracing is the same. In nature it represents in A nine English miles, in B two hundred and sixteen miles, and in C one and a half miles.

Tracing B represents the part of the Mississippi between the mouth of the Arkansas River and that of the Red River. Tracing A represents the Devon Water, a tributary of the Forth, and tracing C represents a quite insignificant brook called the Catter Burn, a tributary of the Endrick, one of the principal affluents of Loch Lomond. These tracings, and indeed the maps of all countries, show clearly the great family likeness exhibited by rivers in all parts of the world. This likeness rests on the fact that in all rivers the relation between the length of an arc or bow and that of its chord is nearly the same. It is an organic rather than a family likeness, and resembles that which exists between dogs of different breeds or builds.

The following table shows, for a selection of well-known rivers, the degree in which the above relation holds good:—

River on the stretch		Length of stretch		Ratio	Number of bows	Average length of bows	
From	To	Direct	Along windings				
<i>Mississippi</i>	Columbus	Memphis	Miles 124	Miles 204	1.65	23	Miles 8.87
	Memphis	Natchez	270	490	1.83	62	8.10
	Natchez	Baton Rouge	88	133	1.51	18	7.39
	Baton Rouge	Carrollton	72	124	1.72	20	6.20
	Columbus	Carrollton	554	955	1.72	122	7.83
<i>Thames</i>	Marlow	Walton	18.7	30.0	1.61		
	Teddington	Isle of Dogs	16.8	26.5	1.58	11	2.4
	Danube	Near mouth	11.4	22.5	1.97	13	1.73
<i>Rhine</i>	Germersheim	Mannheim	kilom. 34.1	69.2	2.03	11	6.3
<i>Main</i>			114	144	1.27	44	3.27
<i>Neckar</i>	Heilbronn	Mannheim	80	112	1.40	26	4.30
<i>Lahn</i>	O. Lahnstein	Limburg	17.2	29.7	1.73		
<i>Mosel</i>	Nr. Coblenz		7.0	10.0	1.43		
<i>Ahr</i>	Altenahr	Ahrweiler	4.6	9.6	2.09		

From the table it will be seen that over a length of nearly one thousand miles of the Mississippi the average length of stream, following the windings, is 1.72 times greater than the direct distance. In the Lahn we find

almost the same factor. The Lower Danube, the Rhine, and the Ahr show a factor approximating to 2. The Main, Mosel, Neckar, and Thames have lower factors. The mean of all the factors is 1.68. For a certain number of the rivers the number of "bows" is given with their average length. The size of the bows stands in some relation to the volume of the river. What that relation exactly is I am not able to state. To arrive at it will require a careful study of the flood waters of the river in connection with the form of its bed. It is the flood waters which form the bed. When the river falls to low-water

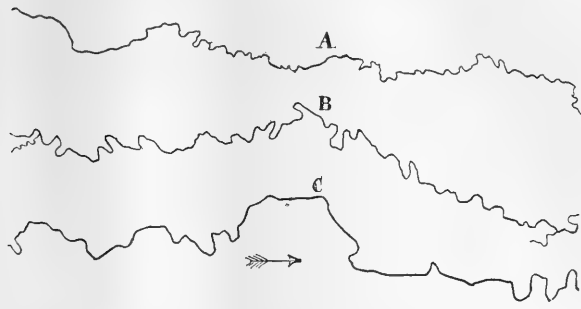

FIG. 1.

level we often see it cutting out a secondary bed on a much smaller scale, which is obliterated by the next following flood.

It may be taken that the mean track of a stream traces the line of lowest level in the valley. Consequently, the ground must rise on both sides of it. The cross-section of the valley through the river resembles that through the middle of a watch glass, rising at first very slightly on both sides of the stream, then more rapidly as the confines of the valley are approached. It is evident that water displaced to one side of the river will, in returning to it, tend to pass to the other side, and to oscillate about the lowest point.

If the bed of a stream flowing through alluvial ground were rectified so as to direct the water along a straight trough cut in the material, it might preserve a straight course for a time, but a stream following such a course

specification until some were obtained which resembled the courses of actual rivers. Fig. 2 shows one specimen out of many which were exhibited at the meeting of the British Association.

It is assumed that the rhythmic motion set up in a mass of water which is disturbed in its uniform rectilinear motion will be reducible to two reciprocating motions, one in the direction of the fall of the stream and the other at right angles to it. When the gradient of the stream is very steep and the nature of the bed homogeneous, as it is in the case of water flowing down the front of a glacier, the longitudinal oscillation is swamped by the powerful and continuous action of gravity, which does not affect the transverse component. In these circumstances we often meet with small streams which describe an almost perfect simple harmonic curve.

In the ordinary stream of the meandering type the gradient is very small, in the case of the Mississippi from 2 inches to 4 inches per mile, so that the longitudinal pulse can produce its full effect. When the two oscillations are simple pendulum motions and have the same period they produce an ellipse, which, when combined with the steady onward flow due to gravity, produces sinuosities unlike those of actual streams. When the period of the transverse oscillation is twice that of the longitudinal one, their combination produces a figure of eight (8). When a figure

of eight is combined with steady forward motion so that both are travelled over in the direction of the arrows in the figure, then it does delineate a curve which may resemble the course of an actual stream. This is illustrated in Fig. 2. In it the sinuous curve falls into three parts, each consisting of a double bow, corresponding to a complete excursion of the tracing point round one of the figures of eight. The horizontal line indicates the path of undisturbed flow of the stream running from left to right in the direction of the arrows. It is divided into seventy-two equal spaces, each of which represents the distance which would be covered by the undisturbed stream in the interval of time in which the circle which generates the transverse reciprocating motion describes one twenty-fourth of a revolution, so that the undisturbed stream passes over twenty-four spaces in the time that the tracing point passes once round the figure

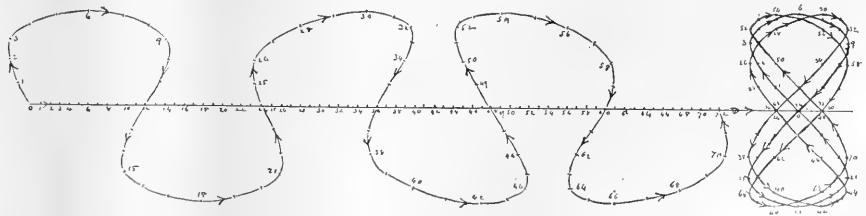

FIG. 2.

is in a state of unstable equilibrium. The smallest accident or obstruction disturbs the uniform rectilinear motion of the water, and tends to induce oscillations, both longitudinal and transverse. These begin immediately to cut into the banks, if they are yielding, and take larger and larger dimensions until they reach a limit when they have produced a course of the sinuosity which corresponds to the laws of the harmonic motion of its waters.

No attempt was made to arrive at these laws *a priori*. The method of investigation used was purely empirical. Curves were traced according to all kinds of harmonic

of eight. The resultant path of the tracing point is the sinuous curve, which cuts the horizontal line at 12 and 24 when the symmetrical 8 is used, and in 36, 48, or 60, 72 when one of the other two figures is used. It is an essential condition that the tracing point shall go round the 8 in the direction of the arrows, so that it shall be moving in the same sense as the undisturbed water when it traverses the outside parts of the figure which are approximately parallel to the path of undisturbed flow. In describing the sinuous line it is convenient to draw the figure of eight on tracing paper. Then, when the

centre of the S is placed over any mark on the horizontal line numbered, say, 9, the point on the periphery of the S numbered 9 must be superposed on the point on the sinuous curve also numbered 9.

The description of the sinuous line is a simple case of mechanical drawing, and presents no difficulty. By varying the harmonic composition of the figure of eight and the rate of undisturbed flow of the water, an infinite number of different individual curves can be produced which are all covered by the same generic specification. It is an interesting occupation, in leisure moments, to compose curves of this kind and to compare them with those traced by actual rivers on the face of the earth.

J. Y. BUCHANAN.

It is not difficult to show the character of the flow at the bottom of a small river. For several years I have taken my students along the course of the river Fender near Birkenhead, and we have conducted experiments which confirm the laws of bottom flow first pointed out by Thomson. At first we put down tubes containing coloured liquids, and the stream-line motion was very clearly shown by lines of colour. Later, I have employed lump sugar soaked in a strong alcoholic solution of magenta. On placing one of these cubes at the outer bend of a curve—the "turnpool"—it is found that the water there is almost stagnant. Gradually an aureole of coloured water forms round the sugar as it dissolves, and this slowly creeps across the stream towards the inner bend. The advantage of this method is that the coloured sugar is several minutes in dissolving, and it is very easily carried about.

For surface flow I have found mahogany sawdust to be the best, as it approaches water in density, and the fine particles are not influenced by air currents.

Although in measuring the surface flow the line of maximum velocity is usually more eccentric than the middle line of the stream, there are cases where the quickest flow is near the inner bend.

In a small experimental river in my laboratory I can produce both effects at will. A river is always tending towards a definite adjustment of its parts to correspond with the characteristics of its flow. The floor becomes graded by the filling of hollows and the removal of obstacles, and the swings become regular and rhythmic like the swings of a pendulum. This condition is seldom found except in the flood plains, and I presume this is the special case referred to by Sir Oliver Lodge.

In the ungraded part many exceptional and interfering circumstances come into play. I have noticed in experimenting with my laboratory river that when the stream has become perfectly adjusted the line of maximum flow is towards the outer curves, but if any disturbing cause is introduced, such as an increase or decrease in the quantity of water flowing in the channel, a variation in the slope of the bed giving a more rapid or gentler fall, or the introduction of an obstacle to form narrows, the normal characteristics of the flow are disturbed, and the maximum flow may be on the inner curve or more violently bent to the outer curve. This is determined by the changed conditions and the tendency of the stream to readjust itself. Prof. Thomson's model, not dealing with graded conditions, may easily have produced the abnormal effects he describes.

A comparison of the flow of a river with that of a glacier shows more points of similarity than most people suppose. In a curved glacier such as the Findelen, the surface at the outer bend is higher than at the inner bend, and the inner bend is always marked by a "toe-cap" moraine like the shallows on the inner curve of a river. It is only reasonable to suppose that this is the result of a cross current under the glacier, such as can be demonstrated in rivers. Moreover, we have in glaciers the phenomena of whirlpools and eddies where tributaries join the main stream.

The phenomena of flow are practically the same whether the medium is solid, liquid, or gaseous. The essential feature of flow is *shearing*. In a stream the surface layers shear over the lower, the mid-stream portion shears

through the lateral parts, and in a meandering course momentum impels the water towards the outer bends and shears it round the slower moving water in the inner bend. So in glaciers and even in solid rocks flowing under earth stresses the same laws apply. The only difference lies in the unit of shear. In the case of liquids and gases this is extremely small, whereas in glaciers it is usually the "Kugel" which gives rise to the corn structure in glacial ice. In rocks the unit varies from masses of gigantic size to others of very small dimensions. This, perhaps, may be regarded as a very crude conception of the meaning of flow, but I have found it useful in giving students a graphic idea of the complicated movements in rivers and glaciers.

The University, Liverpool.

J. LOMAS.

Small Flint Implements from Bungay.

The small flint implements figured in the accompanying drawing were found in a sandy hollow about 2 feet deep at Bungay, in Suffolk. The sand in this hole was littered with minute flakes; in a few minutes I picked up between fifty and sixty, of which the figured ones are typical examples. I hesitate to describe the implements as "pigmy flints," because their fine secondary chipping is not confined to the thicker edge or "back" of the flakes, but, judging from photographs I have seen, they closely resemble some pigmies found recently near Brighton by Mr. H. S. Toms. So far as the untrimmed flakes are concerned, it is impossible to distinguish them from typical

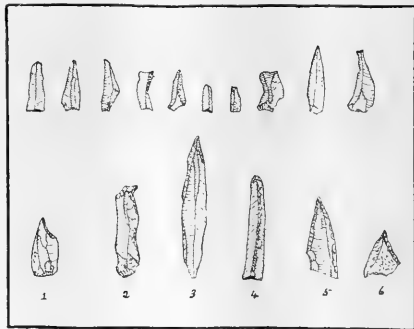

Small flint flakes and implements from Bungay. Two-thirds actual size.

pigmy flakes, while the trimming of implements 3 and 5 is identical with that of the pigmies.

In consequence of nearly all the English pigmies having been found on the surface of the ground, it has been impossible to say with any confidence whether they belong to the Neolithic, Bronze, or Early Iron period. In view of this, it is interesting to know that the small flakes and implements from Bungay were found in association with a polished axe of grey flint, a black flint lance-head of very delicate workmanship, one of the rare and finely chipped triangular "knives," and some small convex scrapers showing very delicate secondary chipping. These implements were found in the same sandy hole when the small implements were discovered, and from an examination of the sides of the hollow it was evident that they all came from what might be called a "Neolithic floor" about 18 inches from the surface of the ground. Nowhere on the surface of the surrounding ground could I find a single flake or implement, and if the ground had not been disturbed in order that a small quantity of sand might be carted away, not one of the implements would have been brought to light. As it happened, they were all found within an area of about six square yards. Some

small bones found on the same site have been identified as those of a girl or a small woman.

The makers of the small flint implements evidently had their home or their "workshop" on a sandy knoll only a few feet above the level of the marshes of the Waveney Valley. On this knoll and a neighbouring one there are some saucer-shaped depressions in the ground very suggestive of hut-circles.

W. A. DUTT.

Lowestoft.

Graphical Interpolation.

SIR GEORGE DARWIN has directed attention (*Mess. of Math.*, 1877; *Phil. Trans.*, A, 1891; "Collected Works," vol. i., p. 319) to the problem of interpolating values of

as a power series is scarcely justifiable, but it will be seen that it makes it easy to draw a smooth curve through the points Q.

F. J. W. WHIFFLE.

Merchant Tailors' School, E.C.

Reflection of Polarised Light.

SOME recent correspondence (vol. lxxvi., p. 637) having directed attention to an error in Preston's "Theory of Light," I venture to send notice of another error in the same work (see article 158). The same error will be found in Prof. Tait's article on light (see p. 611, vol. xiv., of the "Encyclopædia Britannica"), and is repeated in his text-book on light (article 271).

I sent word of the error to the late Sir George Stokes, who expressed himself astonished at it, and said he would look into the matter; but I did not hear from him again, as his letter to me (dated September 19, 1902) was written only five months before his death.

Let the planes of two thin plates of ordinary glass, A and B, be parallel, so that light, which has been completely plane-polarised by reflection from A, falls at the polarising angle upon B. Preston states that this light will be wholly reflected from B, whilst Tait states that this light will be reflected, almost without loss, from B.

As a matter of fact, if we represent by unity the intensity of the polarised beam incident upon B, then the intensity of the light reflected

from B will be represented by about $\frac{2}{3}$, and this takes into account both surfaces of B. The remainder of the beam, about $\frac{1}{3}$, is transmitted. To reflect the whole of the incident beam an infinite number of plates would be

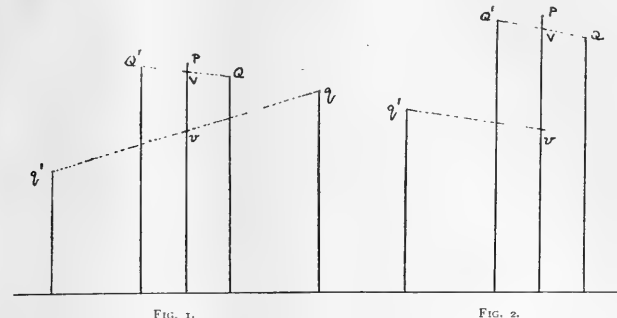

FIG. 1.

FIG. 2.

a function at points each half-way between two consecutive points of an equidistant set, e.g., for determining probable half-hourly values when the hourly ones are found from observations. Let q', Q', Q, q be four points (Fig. 1) with equidistant ordinates u', U, U, u . It is required to find P where the graph through these four points cuts the ordinate half-way between Q and Q' . By taking the origin on the half-way ordinate and writing the function as

$$y = a + bx + cx^2 + dx^3 + \dots$$

we find that if we neglect terms beyond x^3 , then

$$a = \frac{U' + U}{2} + \frac{1}{8} \left(\frac{U' + U}{2} - \frac{u' + u}{2} \right).$$

A rule for determining the point P is accordingly:—join QQ' , qq' and let them cut the central ordinate in V, v respectively, then P lies in vV produced, and $PV = \frac{1}{2}vV$. This rule, although theoretically identical, is simpler in form than that discovered by Sir George Darwin, and seems to be safer, especially near a point of inflexion. It may be worth noticing that in the special case where QQ' and qq' are parallel, the cubic reduces to a parabola, and the rule for finding P is involved in the relation $PV : vV = QV^2 : qv^2 = 1 : 9$. At the beginning and end of the series the rule breaks down, but it can be adapted by assuming the parabolic form for the first and last arcs. In the latter case q is indeterminate, and $q'v$ must be drawn parallel to $Q'Q$ (Fig. 2).

In the diagram (Fig. 3) the rule is applied to an example in which the assumption that the function can be expressed

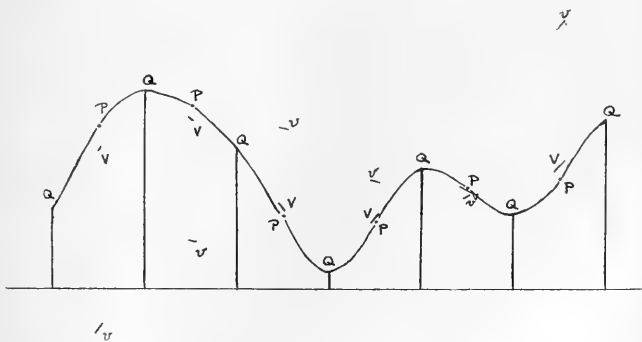

FIG. 3.

required, and the glass would have to be perfectly transparent.

Both authors state correctly that, when the plane of reflection of B is perpendicular to that of A, and the polarised light from A falls at the polarising angle on B, then practically none of this light will be reflected from B.

I therefore think that the mistake arose from accidentally supposing that the total want of reflection in the second case should be balanced, as it were, by a complete reflection in the first case.

C. T. WHITMELL.

Invermay, Hyde Park, Leeds.

THE TOTAL SOLAR ECLIPSE OF
JANUARY 3, 1908.

ON the third day of the approaching new year, according to Greenwich mean time, a total eclipse of the sun will take place, the line of totality passing from a point in the Pacific, about east longitude 155° and north latitude 12° , in a curved path through Polynesia and terminating in Mexico.

Unfortunately for astronomers and others who go far afield to make observations on these occasions, the eclipse is mostly restricted to the ocean, and the only two portions of land from which totality can be seen are two Pacific islands, namely, Hull Island, in the Phoenix group, and Flint Island, to the north of Tahiti.

The accompanying map, Fig. 1, gives a general idea of the path of the line of totality. It is taken from the "Nautical Almanac" for the year 1908, but has here been considerably reduced, and several lines which were not required for this article have been omitted, and the land areas more shaded.

The positions of the two islands to which reference above has been made are denoted by two small circles on the central line. Even these observing stations do not offer those facilities with regard to anchorage, landing, shelter, &c., which make eclipsing easy, as the following particulars, gathered from Dr. Downing's paper in the Monthly Notices of the Royal Astronomical Society, will show.

Hull Island has a lagoon and a little fresh water, and cocoa-nut trees 50 feet high grow on it. The island is surrounded by a coral reef, which makes landing very difficult except by entering the lagoon by means of the boat passages on the north-west side. There is also no anchorage.

Even Flint Island does not offer more enticing facilities. It is 13 feet high, and covered with brushwood and trees, and is $2\frac{1}{2}$ miles long and half a mile broad. Fringing it is a steep coral reef, which at low water is dry and extends seaward about half a cable. At the northern end of the island this reef extends seaward $4\frac{1}{2}$ cables, and at the southern end $2\frac{1}{2}$ cables. Two small lagoons of brackish water are situated in the interior. Landing also is described as very bad even for surf boats, and there is either bad anchorage or none at all.

So far as is known at present, no one intends going to Hull Island, but as Flint Island will be occupied the following data regarding the particulars of totality, gathered from the above-mentioned source, may be of interest. As the island is situated in longitude $151^{\circ} 48'$ W. and latitude $11^{\circ} 26'$ S., the duration of totality is 4 minutes. Such a long eclipse will be specially suitable for the study of some problems, and more especially for those connected with the corona. This station is also very favourable in another respect, because the sun at eclipse time has an altitude of 74 degrees, or only 16 degrees from the zenith.

The following table shows the times of the four contacts of the moon with the sun in both Greenwich and local mean time.

		Greenwich			Local				
		d.	h.	m.	s.	d.	h.	m.	s.
(1)	January 3	7	52	51	January 2	21	45	39	
(2)	"	3	9	22	44	"	2	23	15
(3)	"	3	9	26	44	"	2	23	19
(4)	"	3	11	2	59	"	3	0	55

While the accessibility of the station and the weather conditions are not all that could be wished for, the length of totality, the great altitude of the sun, and the importance of continuity of observation of eclipses are sufficiently tantalising to tempt astronomers to journey to this far-off land.

There is another reason which makes the observation of this eclipse of great importance.

The last eclipse from which successful results were obtained was that which occurred in 1905, the eclipse of 1907 not having been seen in consequence of unfavourable weather conditions. The next after 1908

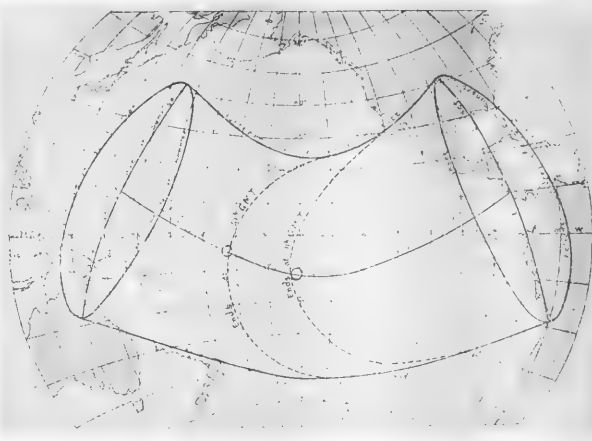

FIG. 1.—The track of the total solar eclipse of January 3, 1908. The small circles on the central line denote the positions of the two islands from which totality can be observed.

will be the eclipse of 1912, which will be visible from South America for one minute. The other eclipses which will take place in this interval are as follows:—

The Greenland and Siberian eclipse of 1909 is an annular one, and therefore not of any importance for physical astronomers.

An eclipse will occur in Tasmania in 1910, but as totality will commence at 4h. 35m. and end at 4h. 64m., and as the sun will set at 4h. 53m. Hobart mean time, the sun will probably be too low for any extensive series of observations.

In 1911 an eclipse track will begin in the south-eastern portion of Australia, pass across the Pacific Ocean, and finish by skirting the coast of Florida.

It may be that some islands lie in the track, in which case this eclipse can be utilised, but at the Australian end of the line the sun will probably have too small an altitude to warrant the sending of expeditions from great distances.

In April of 1912 there will be an eclipse visible in Spain, but until the calculations are published it

is not certain whether it will be "total" or "annular." This uncertainty is due to the fact that the apparent diameters of the sun and moon on that occasion will be so very nearly equal that it will depend on the value of the moon's diameter employed in the computations whether the sun will be totally eclipsed or not. Should it prove, however, to be total, the time of duration will probably be very short. Such an eclipse would most probably be a very valuable one from the point of view of the spectroscopic study of the chromosphere.

It will thus be seen that we shall most probably have to wait until October, 1912, for a favourable eclipse following that of 1908, so it is hoped that the approaching event in the Pacific will be satisfactorily observed.

The accompanying map of the world (Fig. 2) shows the tracks of all the eclipses to which reference above has been made, with the exception of that of April, 1912. This chart is taken from Mrs. Todd's excellent little book, entitled "Total Eclipses of the Sun" (1894), but all those tracks which were

Island and back. The ship put on this special duty is the *Annapolis*, and she will be under the personal command of His Excellency Governor Moore, U.S.N., of the Island of Tutuila, Samoa.

No doubt the officers and men of the *Annapolis* will prove most valuable assistants to Prof. Campbell, as they were found useful in the eclipse of 1905. On that occasion, it may be remembered, the United States Navy Department sent a "special eclipse squadron" of three vessels to Europe, under the command of Rear-Admiral C. M. Chester, U.S.N., the result of which was a complete series of observations only the preliminary results of which have as yet been published.

To describe briefly the scientific staff and instruments which will be conveyed by the *Annapolis*, reference has been made to the contents of an article which recently appeared in the *Journal of the Royal Astronomical Society of Canada* (vol. i., No. 4, p. 254) from the pen of Mr. C. A. Chant.

It is there stated that the party will probably consist of Prof. Campbell, with Messrs. Aitken, Perrine, and Albrecht, of the Lick Observatory; Prof. Lewis, of the University of California; Prof. Abbot and his assistant, and possibly one or two other assistants. They will all sail from San Francisco on November 22, arriving at Tahiti on December 4. The party will then join the *Annapolis* and sail for Flint Island.

With regard to the instrumental equipment, corona pictures on a large and small scale will be secured by a 40-foot focal length coronagraph pointed straight at the sun, and by a 5-inch objective of 70 inches focal length respectively. For the purpose of searching for intra-Mercurial planets, two groups of four cameras each will be pointed towards the east and west equatorial regions of the sun's surroundings.

Objective-prism spectrographs, or prismatic cameras as they are often called, will be employed for obtaining photographs of the spectrum of the chromosphere. In one of these "running" plates will be

used to record the sequences of changes in the spectrum of the sun's limb about the times of second and third contact.

This method was, so far as I am aware, first employed at Sir Norman Lockyer's suggestion in the prismatic camera in my charge at the eclipse of 1896 in Lapland. Unfortunately, clouds prevented any photographs at all being secured. Prof. Campbell successfully applied the method to the eclipses of 1898, 1900, and 1905, and therefore proposes to continue the series.

Other spectrographs included in the programme are one of low dispersion for recording the general structure of the corona, another for the determination of the wave-length of the green coronal line, and a third for studying the form of the gaseous envelope responsible for the green line. For the ultra-violet spectrum of the corona, Prof. Lewis is taking out a large quartz spectrograph. Polariscopic photographs will be undertaken, and a study of the brightness of the corona as a whole will be attempted.

From the above brief sketch it will be gathered

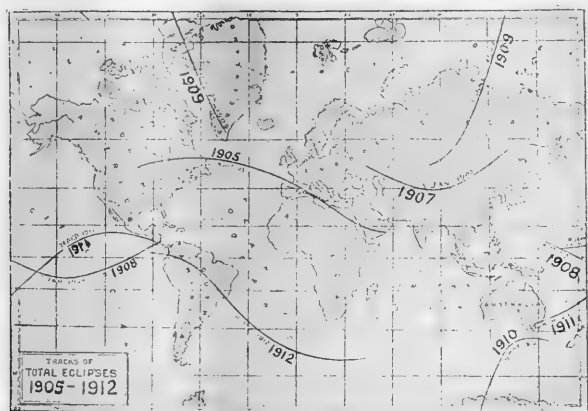

FIG. 2.—Chart showing the tracks of all the total solar eclipses from 1895 to 1912. The 1909 annular eclipse is included also, but the uncertain total eclipse of April, 1912, which might be seen from Spain, is excluded.

not required have been deleted, and the year of occurrence of each eclipse has been printed in larger type.

It is interesting further to point out that the eclipse of 1905 occurred at the time of greatest solar activity as indicated by the sun-spots, while that of 1912 will take place about the epoch of minimum sun-spots.

The eclipse of 1908, occurring in an intermediate year, will therefore be a useful connecting link between the two, and renders it important even from this point of view alone.

The only official expedition which, so far as is known, has made preparations to view this eclipse is the one from the Lick Observatory in America, under the direction of Prof. W. W. Campbell. Flint Island will be the observing station, and Mr. William H. Crocker, of San Francisco, who has defrayed the expenses of five previous expeditions, has again offered to finance this one. The Navy Department of the United States has come forward and provided a war vessel to transport the expedition from Tahiti to Flint

that Prof. Campbell's party is equipped with a fine set of instruments, and that it is prepared to cover a wide field of research.

Although the above will be the only official expedition to the island, an enthusiastic amateur in the person of Mr. F. K. McClean is already wending his way there. Mr. McClean is the son of the late Mr. Frank McClean, F.R.S., who, it will be remembered, besides completing a valuable spectroscopic survey of the brighter stars in both hemispheres, made valuable endowments both to the Cape Observatory and the Cambridge University.

At the eclipse of 1905 Mr. F. K. McClean accompanied the Solar Physics Observatory's expedition to Majorca as volunteer assistant. On that occasion he was in charge of a large coronagraph of 16 feet focal length, which he manipulated successfully, so he is not a novice at eclipse work.

For the coming eclipse he is taking out a fine 22-inch siderostat, one coronagraph, and a small grating spectrograph. The coronagraph consists of a 4½-inch De La Rue objective of 8 feet focal length, which has been used on numerous occasions during eclipses by the Solar Physics Observatory expeditions.

The optical parts of the grating spectrograph consist of a 4-inch Voigtländer of 42 inches focal length, and a Thorp's transparent replica of a Rowland diffraction grating having 14,500 lines to the inch and a ruled surface of 3×2 inches. In the eclipse of 1905 this instrument gave such satisfactory results that Mr. McClean wished to employ it again under, it is hoped, better weather conditions.

Mr. McClean has so arranged his programme that, failing any assistance at the station, he can make exposures in both the instruments. There is little doubt, however, that Prof. Campbell will be able to render him help should he require it.

It may be mentioned that if the *Annabolis* had been able to accommodate more than twelve of the eclipse party Mr. McClean would have been invited to join the Lick expedition. To reach Flint Island he has therefore gone to Auckland *via* Australia, and has chartered a special steamer to take him and his equipment to the island and back. From later information I find that, by arrangement with Prof. Campbell, he will pick up at Tahiti Mr. C. J. Mersfield, of the Royal Society of Sydney, and Mr. Moors, of the Sydney University, both of whom have volunteered to act as Prof. Campbell's assistants, and will convey them to Flint Island and back to Tahiti.

Let us hope that eclipse day will be fine, and that all will return with results which will add to our knowledge of the sun.

A cablegram, dated November 25, from Mr. McClean, at Auckland, states that Mr. Mersfield has joined him and will be attached to the Lick party. He further informs me that Mr. Raymond, of the Sydney Observatory, and Mr. Short, photographer to that observatory, together with the Rev. Mr. Walker, an amateur astronomer at Auckland, are going out with him and will form his party.

WILLIAM J. S. LOCKYER.

NEW AÉROPLANES.

AN account of the successful aéroplane flights by which Mr. Henry Farman has succeeded in breaking the record hitherto held by M. Santos Dumont (in the absence of trustworthy information concerning the experiments of the Wright brothers) has probably been seen by most readers of *NATURE* in the daily papers. We are indebted to an article by M. René Dondière in *La Nature* for the further

details regarding the machine and its performances which form the subject of the present notice.

Mr. Farman's machine has been constructed in the works of Messrs. Voisin Brothers, and is of the well-known cellular form, as shown in the accompanying illustration. The front pair of planes measure 12×2 metres, the height between them being 2 metres. This pair is connected by a framework 4½ metres long with the rear pair of planes, which only measures 6 metres transversely. The vertical rudder is situated between the latter planes, while a horizontal rudder is fixed right in front of the machine. The motors and tanks of petrol are contained in a spindle-shaped case in front, into which is let the seat for the operator.

The motive power is furnished by an eight-cylinder "Antoinette" motor of 40-50 (metric) horse-power, and operates on a propeller the two vanes of which are 2'10 metres across and 1'10 metres in pitch. The whole apparatus rests on four wheels when on the ground. The total wing surface is 52 square metres and the weight 500 kilograms; the length of the machine is 10 metres. At present—or at any rate at the time of M. Dondière's account—the machine has a tendency to take an upward direction on leaving the ground, but while this prevented Mr. Farman from making extended trips, he has nevertheless succeeded in covering 771 to 800 metres at a height of 6 metres above the ground. These records, performed on and after October 26, following after flights of 303 and 350 metres, represented the maximum course obtainable within the limits of the field on which the experiments were made.

In regard to what the average Englishman would call the "practical" aspect of these experiments with reference to the possibilities of aéroplane machines coming into general use, reference is made to the great skill needed in controlling the machine. The operator has to manipulate or observe at the same moment the vertical and the horizontal rudder, the carburettor, the sparking, the pressure gauges of the petrol and water, to listen to the throbbing of the motor, to balance the machine laterally, taking account of the effects of wind, and finally to avoid coming into collision with the crowd of spectators.

Later news states that Mr. Farman has again made several attempts to win the Deutsch Archdeacon prize, but has failed to do so owing to the wheels of his machine grazing the ground, especially in the neighbourhood of the turning points.

Another aéroplane which is also attracting considerable attention at Paris is the "monoplane" of M. Robert Esnault Pelterie. This, unlike most recent types, has only a single transverse supporting surface, which in one machine measured 9'6 metres from tip to tip with a superficial area of 18 square metres; in a more recent machine these dimensions have been reduced to 8'6 metres and 16 square metres respectively. The surface is somewhat concave in form. In addition there is a single horizontal rudder placed at the rear, while the motor and propeller are in the front of the machine. The motor consists of seven cylinders arranged round a circle, and it gives 25 to 30 horse-power with a weight of 44 kilograms. The total weight of the machine and its rider amount to 240 kilograms. For running along the ground the monoplane has two wheels, arranged bicycle-fashion, attached to the body, and two other wheels are attached to the tips of the wings. The recorded performances, which commenced on October 22, include straight flights of about 100 metres and 147 metres, and a path stated to be a semicircle of radius about 1640 feet, which, if correct, represents a flight of, roughly, 1600 metres. But at the end of the flight of 147

metres—the machine fell vertically on the ground, and was damaged.

An aeroplane constructed on the other side of the Atlantic is described in the *Scientific American* for November 16 as "a heavier than air flying machine which lacks the faults of former similar devices according to its inventor, J. W. Roshon, of Harrisburg, Pa. . . ." This machine, which has not yet been tried, is characterised by its complexity to much the same extent that the monoplane is characterised by its simplicity. It has three principal supporting planes, the bottom and middle plane measuring 24 feet transversely by 8 feet longitudinally, while the top plane has only a transverse measurement of 12 feet. Between these three planes, which are placed one above the other, giving a total height of 17 feet, there are 26 narrow flat planes placed transversely at the front and rear of the larger planes. The total wing surface is 900 square feet, say 80 square metres, and the weight with an operator is estimated at 600lb., say 270 kilograms. To launch this large machine into the air an inclined plane has been specially constructed curving up at the bottom in order to start the machine with its rider skyward, but for the first test a bag of sand is to take the place of the latter.

ANNIVERSARY MEETING OF THE ROYAL SOCIETY.

THE anniversary meeting of the Royal Society was held on Saturday, November 30, St. Andrew's Day. Lord Rayleigh, the president, was in the chair. Among the subjects referred to in the report of the council are the publication of the National Antarctic Expedition results, the International Catalogue of Scientific Literature, Royal Society's Catalogue of Scientific Papers; International Association of Academies, sleeping sickness, and Malta fever. The following statement, drawn up by the council, was presented to the Royal Commission on Vivisection in March last:—

The Royal Society, from its age and the position accorded to it among scientific institutions, feels its responsibility as a guardian of the general interests of science in this country. Founded as it was for the promotion of natural knowledge, whenever from time to time legislative changes have been proposed which might seem likely to affect the advancement of that knowledge, the society has desired to make its voice heard on behalf of scientific progress. The recent appointment of a Royal Commission on the subject of experiments on animals has been deemed by the president and council of the Royal Society to be an occasion when they may ask to be allowed

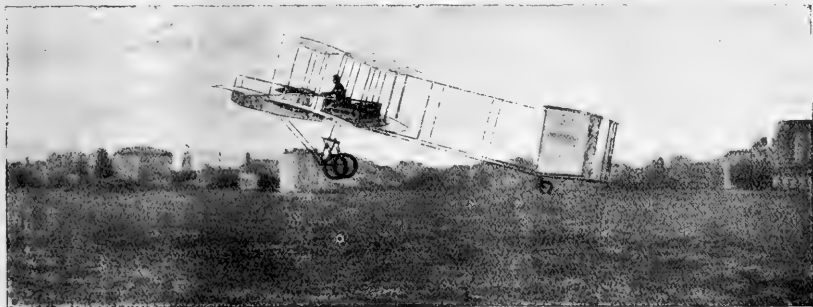

Mr. Farman's aeroplane in full flight. From *La Nature*.

A further departure from the present fashion of machine is the gyroplane of Messrs. Breguet, which revives interest in the attempt to overcome gravity by vertical screw propellers. As at present designed, it is supported by four propellers placed at the corners of a square, each propeller having four revolving vanes, and each vane carrying a pair of superposed planes. The machine, which with its operator would weigh 540 kilograms, was found to hover successfully in the air at a height of a few feet for a minute, this representing the limit of the experiment, and the machine being held down to prevent any accident. It is thus claimed that aerial navigation by vertical screws is possible.

It is interesting to record the fact that the *Scientific American* estimates Mr. Farman's longest flight on October 26 as 2529.52 feet, and his longest measured flight on November 7 as 2624.66 feet. The French records are 771 and 800 metres respectively. Thus, by the use of English units, the American correspondent would appear to claim, if the results are correct, to have estimated these long-distance flights to within an eighth of an inch. But unless the figures represent the results of actual exact measurements (and of this no evidence is given), their accuracy cannot be admitted.

to lay before that Commission a statement of their views on the broad scientific bearings of the question.

There can be no doubt that the main cause of the remarkable development of science in modern times has been the adoption of the experimental method of investigating nature. In every department of research this method has led to the most important advances, both in questions of theory and in practical applications to the useful purposes of life. From the beginning of its history the Royal Society has fostered the prosecution of experiment, not only in physical and chemical, but in biological inquiry, and its publications are full of records of the discoveries which have consequently been made.

In no branches of investigation have the theoretical and practical successes of experimental work been more conspicuous in recent years than in physiology and its practical applications in medicine and surgery. In medicine, the careful and patient testing of the effects of drugs on the lower animals has not only led to an accurate knowledge, not otherwise attainable, of these effects as produced on the human body, but has greatly increased the number of substances now available to the physician in the treatment of disease. Without this method of investigation the progress of pharmacology, in recent years so astonishing and beneficent, would be arrested, and diseases, which may in time be successfully combated, would continue their ravages unchecked. In modern surgery the application of similar experimental work has been attended

with brilliant success. Most delicate and fundamental operations on the human body have been made possible by the knowledge obtained from the treatment of animals.

The president and council of the Royal Society claim that since the continued advancement of science in every department depends so largely upon the use of the experimental method, the utmost caution should be observed in any proposals for legislation whereby the prosecution of the method might be unduly limited. So much has already been gained from the application of experiments on animals, both for the progress of physiology and for the alleviation of human suffering, and so much more may be confidently expected in the future, that the president and council trust that nothing will be done that would hamper the legitimate employment of the method.

While precautions should undoubtedly be taken against improper use of experiment on living animals, it is not the province of the society to suggest what safeguards should be adopted. It is, however, the bounden duty of the president and council to urge that those safeguards should be so framed as not unnecessarily to interfere with that advancement of knowledge to promote which the society exists.

Such restriction would not only cripple or arrest the growth in this country of an important branch of biological science, but in so doing would reduce the efficiency of both physician and surgeon to mitigate or cure disease. It might then become no longer possible to maintain the high position which this country has gained in researches necessary for the advancement of knowledge and for the guidance of medical practice, and the investigators to whose devotion and skill the progress of medical science owes so much might be compelled to seek in foreign universities and scientific organisations the opportunities for research which they could no longer find at home.

This statement is not founded on general knowledge alone. The cooperation of the Royal Society has often been sought by the Government of this country in taking measures to arrest the spread of deadly disease, and to improve the conditions of health in distant parts of the British Empire. Without the ungrudging services of physiologists and pathologists, many of whom the society is proud to count among its fellows, the services thus solicited could not have been given. The president and council gladly avail themselves of this opportunity of testifying to the laborious and unselfish devotion, often in most dangerous conditions, with which the necessary experimental researches have been carried on, and to the value of these researches, not only in enlarging our biological conceptions, but in alleviating the sufferings of mankind.

A further sum of 350*l.* has been voted by the council from the Government grant towards a fund of 2000*l.* which Sir David Gill is endeavouring to raise for the purpose of extending the work of measuring the great African geodetic arc. The grant was voted conditionally upon the 2000*l.* referred to being obtained.

The main part of Lord Rayleigh's presidential address is reprinted below.

An important feature in the work of the Royal Society consists of various inquiries, undertaken for different departments of Government, in regard to diseases which affect the tropical portions of our foreign possessions and dependencies. Among these diseases the attention of the civilised world has been for some years directed to the malady known as sleeping sickness. The first concerted action for the study and combating of this appalling scourge arose out of a representation made by the Royal Society to the Foreign Office in the spring of 1902, in consequence of which, at the request of the Treasury, the society's Malaria Committee organised and dispatched a small scientific commission to Uganda. In the course of a short time the source of the disease was traced by this Commission to the presence of a trypanosome in the blood and cerebro-spinal fluid of the victims, and the further discovery was also made by the same Commission that the trypanosomes are carried by a species of biting (tsetse-fly). These important revelations were followed up by detailed

studies of the character and distribution both of the disease and of the fly. Besides sending out a succession of observers to prosecute the investigations of its Commission at Entebbe, the Royal Society urged upon the Colonial Office the necessity of organising, and under an increased medical staff, a more comprehensive inquiry into the local conditions under which the disease is propagated. This recommendation was carried out, and some valuable information on the subject has been obtained. Meanwhile, though various drugs had been tried with at best only temporary success, no lasting remedy had been found for the malady, which has continued to be fatal and to spread steadily over Central and East Africa.

The various European Governments which have possessions in those regions have at last determined to make a united effort to cope with sleeping sickness through the instrumentality of an International Conference having a separate bureau in each country concerned and a central bureau in London. The object of this cooperation will be to collect information bearing on the disease, to devise and carry out such scientific researches as may seem to be necessary, and to concert measures for dealing with the disease and the populations affected or likely to be affected by it. The Royal Society, having led the way in this subject, has been invited to give the proposed combined international action its support. The society welcomes the proposal, and will be prepared to render every assistance in its power. In the meantime, our Tropical Diseases Committee is continuously and actively engaged in the endeavour to discover a drug that may prove effective in the treatment of the disease. Their investigations have been directed to the study of trypanosomiasis in rats, and the latest results obtained are such as to encourage the hope that at least in this direction their labours have been successful.

During the present year three parts of the reports of the society's Mediterranean Fever Commission have been published, embodying the final observations and conclusions in this important inquiry, which was undertaken at the joint request of the Admiralty, War Office, and Colonial Office. The members of the Commission have shown how the scourge of fever, which has been so long rife in Malta, and has so seriously reduced the strength of our garrison there, may be eventually banished from the island. Already their recommendations, so far as they have been followed, have reduced the amount of fever to trifling proportions. It now remains for the authorities to adopt the further precautions pointed out to them, which will probably banish the disease altogether.

Progress has been made with the National Physical Laboratory's buildings at Eskdale Muir, some of which are now ready for occupation. It was hoped that the work might have begun this summer, and the Treasury has provided a sum of 750*l.* for the expenses during three-quarters of the current financial year. Owing to the bad weather in the early summer this anticipation has not been realised, but a start will be made very shortly. The buildings are admirably adapted for their purpose, and will render possible the study of terrestrial magnetism under the undisturbed conditions which used to exist at Kew.

The completion of the work on the electrical units will be satisfactory to those who have been interested in this question. At the time of my own researches, about twenty-five years ago, the ohm and the ampere were uncertain to 2 per cent. or 3 per cent., and I then scarcely hoped to get nearer than one part in a thousand. The recent work carried on at Bushey would seem to indicate that an accuracy of one part in ten thousand may have been attained. The possibility of such a refinement depends largely upon the use in the instruments of coils composed of a single layer of wire, the position of every turn of which is open to exact determination. The importance of this feature was insisted upon by the late Prof. Jones.

Accuracy of measurement appeals less to the lay and scientific public than discoveries promising to open up new fields; but though its importance at any particular stage may be overrated, it promotes a much needed consolidation and security in the scientific edifice. A remarkable example of enhanced accuracy is afforded by modern measurements of luminous wave-lengths, for which we are

mainly indebted to our Copley metallist. Not only did he introduce the vacuum tube charged with mercury or cadmium as the best source of homogeneous light, but by a most able use of an ingenious method he determined, with the highest precision, the values of the cadmium red, green, and blue wave-lengths in terms of one another, and of the metre. His work has been skilfully followed up by Fabry and Perot, and numerous wave-lengths are now known with a relative accuracy of one millionth part. When we reflect upon the almost ultra-microscopic magnitude of a wave-length of light, the possibility of such an achievement may well excite our astonishment.

For the advancement of science the main requirement is, of course, original work of a high standard, adequately explained and published; but this is not enough. The advances so made must be secured, and this can hardly be unless they are appreciated by the scientific public.

In all the principal countries of the world we have now a body of men professionally connected with science in its various departments. No doubt the attention of many of these is so engrossed by teaching that it would be hard to expect much more from them, though we must remember that teaching itself takes on a new life when touched with the spirit of original inquiry; but in the older universities, at any rate, the advancement of science is one of the first duties of professors. Actual additions to knowledge occupy here the first place; but there must be many who, from advancing years or for other reasons, find themselves unable to do much more work of this kind. It is these I would exhort that they may fulfil their function in another way. If each man would mark out for himself a field—it need not be more than a small one—and make it his business to be thoroughly conversant with all things, new and old, that fall within it, the danger of which I have spoken would be largely obviated. A short paper, a letter to a scientific newspaper, or even conversation with friends and pupils, would rescue from oblivion writings that had been temporarily overlooked, thereby advancing knowledge generally, and sometimes saving from discouragement an unknown worker capable of further achievements. Another service such experts might render would be to furnish advice to younger men desirous of pursuing their special subject.

A movement is on foot, and has already received valuable support, to promote the publication of standard scientific works in embossed type suitable for the use of the blind. Mr. H. M. Taylor tells me that in the course of the last twelve months he has written out the whole of Mr. C. Smith's "Elementary Algebra" in Braille type, has afterwards read the copy with his fingers, and again, later, read the whole in proof. There can be no doubt that books in embossed type on such subjects as mechanics, physics, astronomy, geology, not to mention the various biological sciences, would be an immense boon to many blind readers. I commend the proposal heartily to your notice.

Another remedy for the confusion into which scientific literature is liable to fall may lie in the direction of restricting the amount of unessential detail that is sometimes prevalent in the publication of scientific results. In comparing the outputs of the present time and of, say, thirty years ago, the most striking feature that appears is doubtless the increase of bulk, in recent years coming especially from young workers stimulated by the healthy encouragement of direct research as a part of scientific education. But I think it may also be observed, and not alone in the case of such early dissertations, that there is, on the whole, less care taken for the concise presentation of results, and that the main principles are often submerged under a flood of experimental detail. When the author himself has not taken the trouble to digest his material or to prepare it properly for the press, the reader may be tempted to judge of the care taken in the work from the pains taken in its presentation. The tendency in the subjects to submit for immediate publication the undigested contents of note-books is one that we hear much of at the present time. It is a matter that is difficult for publishing bodies to deal with, except by simple refusal of imperfectly prepared material, with its danger of giving offence to authors of recognised standing, but it seems not unlikely that at present public scientific opinion would endorse such a

course of action. A related difficulty, and one that contributes to this trouble, is the tendency, noticeable in some public scientific organisations, to imagine that their activity is estimated by the number of pages of printed matter they can produce in the year. Probably no consideration is further removed than this from the minds of the educated public, whose judgment is alone worth considering.

COPLEY MEDAL.

The Copley medal is awarded to Prof. Albert Abraham Michelson, For.Mem.R.S., on the ground of his experimental investigations in optics.

In 1879 Michelson brought out a determination of the velocity of light by an improved method, based on Foucault's, which gave 299,800 kilometres per second. Three years later, by means of a modification of the method, capable of even greater precision, he found for this constant, of fundamental importance for electric as well as optical science, the value of 299,853 kilometres.

Michelson has been a pioneer in the construction of interferometers, which are now indispensable in optics and metrology. With his new instrument, at Paris, he determined the absolute wave-lengths of the red, green, and blue lines of cadmium by counting the number of fringes (twice the number of wave-lengths) corresponding to the length of the standard metre of the Bureau International des Poids et Mesures. He found the metre to be 1,553,164 times the wave-length of the red line of cadmium, a result which is almost in exact agreement with the re-determination last year by Perot and Fabry. Michelson thus proved the feasibility of an absolute standard of length, in wave-lengths, of such accuracy, that if the standard metre were lost or destroyed it could be replaced by duplicates which could not be distinguished from the original.

He had the greatest share in the elaboration of precise experiments on the relative motion of ether and matter. He repeated in an improved form Fresnel's experiment of the speed of light in moving media, using water and sulphide of carbon. He found that the fraction of the velocity of the water by which the velocity of light is increased is 0.434, with a possible error of ± 0.02 . The fact that the speed is less in water than in air shows experimentally that the corpuscular theory is erroneous; but his results, moreover, established the correctness of Fresnel's formula for the effect, the theory of which has since become well understood.

In conjunction with E. W. Morley, he devised and carried out a very remarkable method by which, on the assumption of ether at rest, an effect depending on quantities of the order $(v/V)^2$ would appear to be appreciable. No displacement of the fringes was found. Of this result the simplest explanation would be that the ether near the earth partakes fully in its orbital motion; but modern electric and optical science appears to demand a quiescent ether, and the existence of this and similar null results is fundamental for its theory.

He has shown the possible application of the interferometer method to astronomy, by himself measuring the diameters of the four satellites of Jupiter, which are only about one second of arc. He suggests the further application of the instrument to such of the fixed stars as may not subtend less than one-hundredth of a second of arc.

In 1898 Michelson constructed a spectroscope which enables us to make use of the great resolving powers of the very high orders of spectra, which are absent in the use of the ordinary grating, and with the added advantage of having most of the light in one spectrum. The echelon consists of a pile of glass plates of precisely equal thickness, which overlap by an equal amount; with it spectral lines which appear single with the most powerful gratings can be resolved into components. This instrument has been especially useful for the direct observation of the important, because definite, influence of magnetism on light, discovered by Zeeman. With thirty plates, and using the 25,000th spectrum, the echelon has a resolving power of 750,000, while the most powerful gratings do not exceed 100,000.

In connection with the analysis of radiations, he has constructed and used various machines for the analysis of periodic motions. For example, in conjunction with

Stratton, he perfected a remarkable machine which is based on the equilibrium of a rigid body under the action of springs.

Prof. Michelson has also investigated by his interferometer the important subject, both theoretically and practically, of the breadth and the structure of spectral lines, including the effect of a magnetic field, and in various other ways his genius has opened up new ground in experimental optics.

ROYAL MEDALS.

One of the Royal medals has been awarded, with the approval of His Majesty, to Dr. Ernest William Hobson, F.R.S.

During the last twenty years Dr. E. W. Hobson has been distinguished for the fundamental character of his contributions to mathematics and mathematical physics. His earlier published work, from 1888 onwards, deals largely with the so-called harmonic analysis, which embraces many topics having for their common aim the solution of the potential equation in forms suitable for application to the problems of physics. The exhaustive examination of the general types of harmonic functions contained in his paper in the *Phil. Trans.*, 1896, has been found to be of high utility for this application. He was led by these researches, and particularly by the difficulty of describing in general terms the characteristics of a function capable of being represented by Fourier's series, to take part in the revision of the logical basis of differential and integral calculus which is now in progress; his presidential address to the London Mathematical Society in 1902 on the questions here arising aroused general interest among mathematicians, and he has recently (1907) published an extensive volume dealing with the whole matter and its applications to the theory of Fourier's series, which is of great importance for the history and development of mathematics.

His Majesty has also approved the award of a Royal medal to Dr. Ramsay H. Traquair, F.R.S. Dr. Traquair is honoured on the ground of his long-continued researches on the fossil fishes of Palaeozoic strata, which have culminated, within the past ten years, in his discovery of new groups of Silurian and Devonian fishes, and in his complete exposition of the structure of *Drepanaspis*, *Phlyctenaspis*, and other remarkable forms.

For nearly forty years Dr. Traquair has been busy with the description of fossil fishes, mostly from the Palaeozoic rocks of Scotland, and he is deservedly held to be one of the most eminent palaeontologists of the day. He has been highly successful in the interpretation of the often very obscure and fragmentary remains which he has had to elucidate, and his restorations of fishes have won such credit as to appear in all modern text-books of palaeontology. It may be said that his work, notwithstanding the great difficulties of the subject, has well stood the test of time.

Dr. Traquair has done much to advance our knowledge of the osteology of fishes generally. His earliest memoirs on the asymmetrical skull of flat-fishes and on the skull of *Polypterus* remain models of exactness. His acquaintance with osteology enabled him to show how former superficial examination of the Palaeozoic fishes had led to wrong interpretations. He demonstrated that *Chirolepis* was not an Acanthodian, as previously supposed, but a true Palaeoniscid. In 1877 he satisfactorily defined the Palaeoniscidae and their genera for the first time, and conclusively proved them to be more nearly related to the sturgeons than to any of the other modern ganoids with which they had been associated. He thus made an entirely new departure in the interpretation of extinct fishes, replacing an artificial classification by one based on phylogenetic relationship. His later memoir on the *Platysomidae* was equally fundamental and of the same nature.

All subsequent discoveries, many made by Traquair himself, have confirmed these conclusions, which are now universally accepted.

In 1888 Dr. Traquair demonstrated the dipneustan nature of the Devonian *Dipterus*, and somewhat later he began the detailed study of the Devonian fishes. His latest researches on the Upper Silurian fishes of Scotland are equally important, and provide a mass of new know-

ledge for which we are indebted to his exceptional skill and judgment in unravelling the mysteries of early vertebrate life.

DAVY MEDAL.

The Davy medal is awarded to Prof. Edward Williams Morley. Prof. Edward W. Morley is well known both to chemists and to physicists for his work in the application of optical interferences and other physical phenomena to increase the accuracy of measurement. Numerous valuable papers have appeared, either in collaboration with Prof. Michelson and others, or in his own name, on such subjects. Special reference may be made to his experiments, in conjunction with Prof. Michelson, on the fundamental question of the absence of effect of translatory motion of material bodies on luminous phenomena.

His claim to the Davy medal rests on grounds closely related to these researches, for he has combined throughout mastery of accurate measurement with an intimate knowledge of modern chemistry, and has utilised them in his attempt to solve one of the most difficult and fundamental problems of chemical science. The special problem to which he has consecrated many years of his life is the determination of the relative atomic weights of hydrogen and oxygen; it has been attacked by him with rare insight and skill, and with indomitable perseverance, and he seems to have settled it for many years to come, if not permanently. All the recent work devoted to this problem, and there has been much, has tended to establish more firmly the ratio arrived at by Prof. Morley.

His determinations of the absolute weights of a litre of hydrogen and of oxygen, and his investigations of the amounts of moisture retained by gases dried by various desiccating agents, are of the very greatest importance for scientific progress.

SYLVESTER MEDAL.

Prof. Wilhelm Wirtinger, of Vienna, is the recipient of the Sylvester medal. He is distinguished for the importance and wide scope of his contributions to the general theory of functions. Our knowledge of the general properties and characteristics of functions of any number of independent variables, and our ideas for the further investigation of such functions, are, for the most part, at present bound up with the theory of multiply-periodic functions, and this theory is of as great importance for general solid geometry as the ideas of Abel have proved to be for the theory of plane curves. Prof. Wirtinger has applied himself for many years to the study of the general problems here involved. A general summary of his researches is given by him in the Abel centenary volume (xxvi., 1902) of the "*Acta Mathematica*." Two of his papers may be particularly referred to, both of 1895. One of these deals with the reduction of the theory and general multiply-periodic functions to the theory of algebraic functions, with a view to their expression by Theta functions; this was one of the life problems of Weierstrass, who did not, however, during his lifetime, publish anything more than several brief indications of a method of solution. Prof. Wirtinger's memoir obtains a solution, and is, moreover, characterised throughout by most stimulating depth and grasp of general principles. This paper was followed by two others, one continuing the matter in detail, the other making an application of its principles to the general theory of automorphic functions. Another extensive paper, which obtained the Beneke prize of the Royal Society of Göttingen, deals with the general theory of Theta functions. In it he obtained results of far-reaching importance, for geometry as well as for the theory of functions, the full development of which will require many years of work.

HUGHES MEDAL.

The Hughes medal is awarded to Principal Ernest Howard Griffiths. Principal Griffiths has conferred great benefit on physical science by his series of measurements of fundamental constants, mainly in the domain of thermal and electric energy. At a time when the equivalent of the thermal unit in mechanical energy stood urgently in need of revision, he devoted himself to the problem with all the refinements and patient manipulation that could be devised, the result being a value for Joule's equivalent which at once acquired authority in the light of the

evidence produced, and largely confirmed the corrections already advanced by Rowland and others. A main cause of discrepancy had been found to be the variation of the thermal capacity of water with the temperature; and by an investigation in which this variation was determined, Griffiths elucidated and correlated fundamentally the work of previous observers, from Joule onward. Of special importance also, in the domain of chemical physics, was an investigation of the depression of the freezing point of water by very dilute admixture of dissolved substances, wherein he verified, with all the refinement of absolute physical determinations, that the change of freezing point ran exactly parallel to the electric conductivity when the dilution of the electrolysable salt was comparable to that of gases, being twice as much per molecule as the standard value of the depression for non-electrolytes.

BUCHANAN MEDAL.

The Buchanan medal is awarded to Mr. William Henry Power, C.B., F.R.S. Mr. Power's services to hygienic science and practice have extended over a period of more than thirty years, and have been of the most distinguished kind. He has himself personally conducted successful inquiries into the causes of the spread of various diseases, and has obtained results which have proved of the greatest benefit to mankind. Moreover, in his long connection with the medical department of the Local Government Board he has planned and directed numerous general and local investigations whereby our knowledge of disease, and of the methods of coping with it, have been greatly increased. The medical reports issued by the Local Government Board, which are universally regarded as among the most important contributions of our time to this subject, have for many years past been either written by him or owe much to his editorial criticism and supervision. It is not too much to say that no living man in this country has advanced the cause of scientific hygiene more than Mr. Power, or is more worthy of the distinction of the Buchanan medal.

In the evening of the anniversary meeting, the fellows of the society and their guests dined together at the Whitehall Rooms of the *Hôtel Métropole*. Lord Rayleigh was in the chair, and responded to the toast of the Royal Society proposed by Lord Dunedin. Speeches were also made by several of the medallists, and by Lord Fitzmaurice and the Dean of Westminster.

NOTES.

IN proposing the toast of "The Royal Society" at the anniversary dinner on Saturday last, Lord Dunedin referred to the popularisation of science as one of the functions of a society which exists for the promotion of natural knowledge. This remark provides the subject of a letter by an anonymous correspondent in Tuesday's *Times*. The writer urges that the neglect of science in this country is largely due to the indifference shown by scientific men to the intellectual interests of the average reader. Few men of science make any attempt to describe their investigations in language which can be understood by men of culture without special scientific knowledge, and it is scarcely too much to say that most investigators are so closely absorbed in their particular researches that whether the world in general knows anything of the results or not is regarded as no concern of theirs. This spirit, and the obscure and diffuse manner in which scientific investigations are often described are to be deplored. Lord Rayleigh, in the presidential address which appears elsewhere in this issue, directs attention to the undigested material often presented as papers to scientific societies; and it seems as if the zeal for research is rarely accompanied by the aspiration for simplicity of expression. Prof. M. E. Sadler suggests in Wednesday's *Times* that the neglect of the teaching of the mother tongue in our schools provides a reason "why so many Englishmen of learning and high scientific attain-

ment are unable to express themselves in a lucid and stimulating way." It may be pointed out, however, that though rhetoric receives more attention in the United States than it does in this country, the style of scientific papers and other works from America is not superior to that of our own scientific literature. But whatever the explanation may be, there can be only one opinion as to the advantage of increasing interest in scientific work by making the results as widely known as possible.

THE formation of the Royal Society of Medicine has already been the subject of a congratulatory note in these columns. The inaugural dinner of the society, held on Tuesday last, December 3, was a remarkable testimony to the successful establishment of what Sir Ray Lankester described on that occasion as the National Academy of Medicine. The society consists of thirteen federated sections, representing fifteen pre-existing societies, and it is hoped that other sections will be included before long, so that no branch of medical knowledge will be unrepresented in the society. The number of fellows is upwards of 1800, and of members above 600, and there is every reason to anticipate that these numbers will be considerably increased now that the society is in full working order. The library, which has been strengthened by the inclusion of those of the Odontological and Obstetrical Societies with that of the Royal Medical and Chirurgical, now consists of upwards of 70,000 volumes, and in the reading-room of the society no fewer than eighty-nine British and 180 foreign periodicals can be consulted. Sir W. Church, president of the society, who presided at the dinner on Tuesday, bore testimony to the manner in which the various bodies now forming the Royal Society of Medicine have been willing to sacrifice somewhat of their independence and individual prestige for the common good. Never in the history of medicine has there been a time in which so wide a field has engaged the attention of medical men as the present. In every department of medicine, science has placed at the disposal of medical men new methods and fresh means, not only for the investigation, but also for the treatment of disease, and the ground to be covered in each branch of medicine must as time goes on necessarily increase. To provide every facility for diffusing the increased knowledge which is being gained and enable the profession to keep in touch with what is going on is perhaps at the present time the main object of the society; but the time will come, and that soon, when the Royal Society of Medicine will be in a position, not only to discuss the value of the researches brought to its notice, but also, through the appointment of scientific committees, to add to knowledge.

THE Lalande medal has been awarded by the Paris Academy of Sciences to Mr. Thomas Lewis, of the Greenwich Observatory, and secretary of the Royal Astronomical Society.

SIR W. H. BENNETT, K.C.V.O., has been elected president of the Incorporated Institute of Hygiene in succession to the late Sir W. H. Broadbent, F.R.S.

AN experiment in the breeding of Maine lobsters in the Pacific Ocean is about to be tried by the U.S. Commission of Sea and Shore Fisheries. A car-load of seed lobsters has already been dispatched by a fast express from the Government hatchery at Boothbay to the western coast.

By the death of Mr. M. Walton Brown, which occurred on November 22, the Institution of Mining Engineers loses an indefatigable secretary and the profession of coal mining one of its most useful representatives. Mr. Walton Brown was the author of numerous papers on mining.

engineering, and was the recognised authority in this country on the scientific principles of colliery-ventilation.

A DISCUSSION on the subject of "Rivers Pollution from the Naturalist's Point of View" will be introduced by Prof. R. Meldola, F.R.S., at a conference meeting to be held, under the auspices of the Essex Field Club, on Saturday, December 14, at 6 p.m., in the physical lecture theatre of the Municipal Technical Institution, Romford Road, Stratford, Essex.

At the meeting of the Cardiff City Observatory Committee on November 30 it was announced that arrangements are busily proceeding for the installation of a seismograph at the observatory on Penylan Hill. The seismograph is being provided by the Cardiff Naturalists' Society, its upkeep being undertaken by the city council. It is hoped that the instrument will be installed early in the new year, and that Prof. Milne will be able to attend the opening. Prof. Milne has urged the establishment of a seismograph at Cardiff, which will form a triangle with the existing stations at Birmingham and Shide.

We are pleased to learn that Mr. Haffkine has accepted an appointment to a post at Calcutta offered to him by the Secretary of State for India. It will be remembered that Mr. Haffkine was held responsible for an unfortunate accident that occurred in the Punjab in connection with plague inoculation, an accident for which a large body of scientific opinion has pronounced him to be in no way to blame. So far the Secretary of State has recognised the strength of that opinion, but we could have wished that the recognition had taken a form more complete and more in accordance with the true circumstances of the case.

The Paris correspondent of the *Times* reports that Dr. Jean Charcot, who conducted a successful expedition to the South Polar regions two years ago, is now engaged in the preparation of another expedition to the Antarctic circle. The State has made a credit grant of 24,000*l.* toward the cost, but at least 6000*l.* more will be required. Dr. Charcot intends to start next July. He will proceed by way of Buenos Ayres and Cape Horn to the Antarctic region which he discovered and named "Terre Loubet." The Marquis de Dion has offered Dr. Charcot some motor sledges, so that dogs will not be needed.

The annual conversazione and exhibition of new apparatus, heretofore held under the auspices of the late British Electro-Therapeutic Society, but now under the electro-therapeutical section of the Royal Society of Medicine, will be held in the Queen's (small) Hall on Friday, December 13. The leading makers of electro-medical and X-ray apparatus are taking part, and many new designs will be shown, so far as possible under working conditions. Communications regarding cards of admission or other matters must be addressed to Dr. Reginald Morton, hon. secretary, 22 Queen Anne Street, Cavendish Square, London, W.

The American Association for the Advancement of Science will meet at Chicago on December 28. The business meetings commence on December 30, in the morning of which the first general session will be held, and the new president, Prof. E. L. Nichols, will be introduced by Dr. W. H. Welch, the retiring president. In the afternoon addresses will be given by some of the presidents of sections. Prof. Edward Kasner will speak on "Geometry and Mechanics" to the section of mathematics and astronomy; Mr. Richardson will address the section of chemistry on "A Plea for the Broader Education of the

Engineer," and Prof. Conklin will deliver his address to the section of zoology. In the evening of the same day the retiring president will deliver his address. On December 31 Prof. W. C. Sabine will address the section of physics on the "Origin of the Musical Scale"; Mr. Conant the section of social and economic science on the "Influence of Friction in Economics"; and Dr. Flexner the section of physiology and experimental medicine on "Recent Advances and Present Tendencies in Pathology." Messrs. MacDougal, Warner, and Brown will respectively address the sections of botany, mechanical engineering, and education on subjects to be announced later. Mr. Charles L. Hutchinson is the chairman of the local committee, and Mr. J. Paul Goode is the local secretary.

The following are among the lecture arrangements at the Royal Institution before Easter:—Sir David Gill, a Christmas course of six illustrated lectures on "Astronomy, Old and New," adapted to a juvenile auditory; Dr. A. A. Gray, two lectures on the internal ear of different animals; Prof. W. Stirling, six lectures on membranes, their structure, uses, and products; Dr. E. A. Wallis Budge, three lectures on the Egyptian Sudan, its history, monuments and peoples, past and present; Prof. W. W. Watts, two lectures on (1) the building of Britain, (2) recent light on ancient physiographies; Prof. W. Somerville, two lectures on wood, its botanical and technical aspects; Sir John Rhys, two lectures on Celtic; Dr. R. T. Glazebrook, two lectures on physics; Mr. R. Lydekker, two lectures on (1) the animals of Africa, (2) the animals of South America; Prof. Gisbert Kapp, the electrification of railways; and Prof. J. J. Thomson, six lectures on electric discharges through gases. The Friday evening meetings will commence on January 17, when Prof. T. E. Thorpe will deliver a discourse on the centenary of Davy's discovery of the metals of the alkalis. Succeeding discourses will probably be given by Colonel David Bruce, Prof. E. Rutherford, Dr. C. W. Saleeby, Sir Oliver Lodge, Prof. W. A. Bone, Prof. J. Milne, Prof. A. E. H. Love, the Hon. R. J. Strutt, and Prof. J. J. Thomson.

By the death (which was announced in the *Times* of November 28) of Dr. Carl Bovallius, late professor of zoology at the University of Upsala, Sweden has lost one of her most eminent ethnologists, naturalists, and scientific explorers. A graduate of Upsala, Bovallius took the degree of Ph.D. in 1875, and from some time after that date held the chair of zoology until 1897. In zoology his main subjects were Mollusca and Crustacea, especially the amphipod group of the latter, and the Swedish representatives of both groups. "Contributions to a Monograph of the Amphipoda Hyperidea" is the title of one of his works, the first part (in two numbers) of which was published at Stockholm, 1887-9. It is only by this single part, which appears to be all that was issued, that his name is represented in the catalogue of the Zoological Society's library. Forestry was another of his specialities, and from reports furnished by him as the results of investigations undertaken between 1889 and 1895 the present forest laws of Sweden were based. As an explorer and surveyor he travelled much in Central America from 1881 to 1883, returning again to Nicaragua in 1900, while in 1898-9 he visited southern Venezuela and the Amazons. From these countries he brought extensive zoological and ethnographical collections. In the obituary notice in the *Times* of November 29 he is reported to have made important contributions to the natural history departments of the British Museum, but his name does not appear as a donor in the recently published volumes on the "History of the

Collections" in those departments; and his donations appear to be limited to a few river crustaceans. Dr. Bovallius was the recipient of several decorations from his own and foreign sovereigns, among these being the Grand Cross of the Order of Isabella Catholica and the knighthood of the Danish Order of the Dannebrog, and of the Portuguese Order of St. Iago.

THE ascidians collected on the coast of California by the U.S. Fisheries steamer *Albatross* during the summer of 1904 include a number of new species, which are described by Mr. W. E. Ritter in the Zoological Publications of California University, vol. iv., No. 1.

THE greater portion of the October issue of the *American Naturalist* is occupied by a paper by Mr. A. W. Grabau on orthogenetic variation (i.e. variation along definite lines) in the shells of gastropod molluscs. Among the points discussed are the mode of arrangement and development of ribs and spines on the shell.

To Messrs. Witherby and Co. we are indebted for a copy of an illustrated pamphlet entitled "Gilbert White of Selborne." The text formed the subject of a lecture delivered before the Hastings and St. Leonards Natural History Society in June last by Mr. W. H. Mullens. The illustrations include several views of Selborne village, and one of the interior of the church. A good summary of the chief features of White's career will be found in this well-got-up pamphlet, of which the price is half-a-crown.

IN No. 1567 (vol. xxxiii., pp. 197-228) of the Proceedings of the U.S. National Museum, Lord Walsingham describes a number of new North American moths of the tineid group, with the addition of a list of genera of the family Blastobasidae. The specimens on which the determinations are based were in part supplied by the U.S. Museum and U.S. Department of Agriculture, and in part contained in the author's own collection. Types of most of the new species are now in the U.S. Museum. Soft river-tortoises (Trionychidae) from various Tertiary horizons in the United States form the subject of a paper by Mr. O. P. Hay published in the Bulletin of the American Museum of Natural History, vol. xxxii., pp. 847-863.

To the November issue of the *Zoologist* Mr. W. L. Distant, the editor, contributes the second and concluding part of his article on the extermination of animals, dealing in this instance with the destruction dealt by man. After referring to the destruction of African antelopes and quaggas for the sake of their hides, the author quotes a statement to the effect that in the twenty years from 1856 to 1876 Africa supplied Europe with an annual average of 1,500,000 lb. of ivory, in addition to 250,000 lb. exported to India and about 150,000 lb. to America, this representing the destruction of about 51,000 elephants. Another item which bulks very large is the toll of alligators killed in Florida for their hides, this being estimated at no less than two and a half millions. In Australia, again, we find a flock-owner boasting that in the course of eighteen months he had killed, on his own estate, 64,000 of the smaller marsupials, such as wallabies and kangaroo-rats, in addition to several thousand kangaroos. As the author well remarks, no species can stand such wastage long, and kangaroos and their kin must apparently be exterminated as wild animals at no very distant date.

To vol. xvi. of the *Annales* of the National Museum of Buenos Aires Dr. F. Ameghino contributes no less than 135 pages of "preliminary notes" on an atlas vertebra and imperfect femur (which, so far as we see, may or

may not be associated) from the later Tertiary deposits of Monte Hermosa. On these two specimens, coupled with certain alleged evidence of the existence of an intelligent being at the time the Monte Hermosa strata were deposited, he considers himself justified in naming a new genus and species—*Tetraprothomo argentinus*—of the family Homonidae. Nor is this all, for in the latter part of the paper he publishes a series of phylogenies in which the Ungulata and Primates, together with the Patagonian extinct Carnivora, are derived from a single South American ancestral type, the Microbiotheriidae, a group which most palæontologists now regard as inseparable from the opossums. On a later page we are furnished with the names of a number of non-existent connecting links between "Tetraprothomo" and man and gibbons on the one hand, and earlier forms on the other. It may be added that in one of the hypothetical genera is included the Neanderthal man under the name of *Prothomo neanderthalensis*.

THE fifth annual report of the Horniman Museum and Library, Forest Hill, S.E., dealing with the work of the year 1906, has been issued. The museum is intended to be a teaching institution where the general public, students, and school children may be able to inspect properly labelled specimens exhibited in related series. Saturday morning lectures for teachers and afternoon lectures for the general public have been held with much success. The report contains illustrations of some of the models made by the museum naturalist to illustrate natural phenomena. Among these are diagrammatic models of coral reefs designed to illustrate the manner in which they are built up and the effects of currents on the growth of the reefs. Useful though these models are, their scientific value would have been increased had they been modelled to a true scale, and some indication of the scale given.

THE Bulletin of the Johns Hopkins Hospital for November (xviii., No. 200) contains an interesting paper by Dr. Arthur Meyer on the physician and surgeon in Shakespeare.

THE pages of the *Journal of Hygiene* for October (vii., No. 5) are mainly occupied with two papers on ship beri-beri and scurvy by Prof. Holst and Dr. Frölich. It is stated that ship beri-beri is closely connected with food, and shows a marked congruence with scurvy. By keeping animals on certain diets, conditions were produced simulating human scurvy very closely. The etiology of tropical beri-beri is considered to be outside the field of these investigations.

THE reports of the Board of Health, New South Wales, on the outbreaks of plague at Sydney are important contributions to the epidemiology of this disease, and show conclusively the interdependence of the 'rat and plague. The latest report, by Dr. Ashburton Thompson, deals with the sixth outbreak, which occurred in 1906. A continuous outlook is kept for infection in rats, large numbers of which are caught and examined. In the fifth outbreak, in 1905, the last case of plague in man occurred on July 12, and the last plague-infected rat was identified, on December 5. In 1906, the first plague-rat was identified on January 23, the first case in man occurred on March 12, the last on December 22, and the last plague-rat was identified on December 29. From December 6, 1905, to January 22, 1906, 3225 rats and mice were examined and found to be plague-free. During the epizootic period, January 23 to December 29, 1906, 27,731 rats and mice were examined, among which plague was identified in

174 rats and mice. It is again shown, therefore, that the plague epidemic is preceded by an epizootic among the rats and mice. Notes are given on the species of rodents affected, and on the clinical details of the cases.

THE Bulletin of the Department of Agriculture, Jamaica (August and September), contains articles on the subject of curing vanilla pods for market and on the vanilla industry, also on bastard logwood and cacao cultivation.

WE have received from Messrs. A. E. Staley, of Thavies Inn, London, a list of Bausch and Lomb's new microscope models fitted with an improved form of fine adjustment, also a brochure on the use and care of the microscope.

THE development of the pollen grain in the gymnospermous genus *Dacrydium* is interesting because, according to the account contributed by Miss M. S. Young to the *Botanical Gazette* (September), a number of cells are formed in what is technically known as the microgametophyte. The spore passes out of the single-cell stage when a small prothallial cell is cut off; by another division of the vegetative nucleus a second prothallial cell is formed, and in a similar way a third, the generative cell, is produced. The generative cell gives rise to a sterile and a so-called body cell, the progenitor of the sperm cells. As the second prothallial cell not infrequently divides, the mature pollen grain may show as many as seven nuclei.

IN the *Engineering Magazine* (vol. xxxiv., No. 2) a new mineral industry, the manufacture of radium, is described by Mr. Jacques Boyer. He gives illustrations of the works lately installed at Nogent-sur-Marne, where wagon-loads of various minerals (pitchblende, autunite, chalcotite, carnotite, and thorianite) are treated for an ultimate production consisting of a few minute particles of radium salts.

THE Institution of Engineers and Shipbuilders in Scotland has reached its jubilee year, and in his presidential address Mr. John Ward gave an able retrospect of the events connected with the work of the institution, a subject especially suitable in view of the fact that it is also the centenary of marine engineering as applied successfully to ocean navigation. To the address, which is printed in the *Transactions* (vol. li., No. 1), is appended a useful chronology of events in the evolution of the marine steam engine.

THE problem of peat utilisation, so often pronounced hopeless, may now be considered as practically solved. The Mond Power-Gas Corporation is building a large peat-generator gas-plant near Herne, in Westphalia; Messrs. Crossley Brothers are projecting plants on the basis of their long-continued experiments at Openshaw; and Martin Ziegler has made peat-coke and obtained the chemical by-products, at Oldenburg and at other places, ever since 1807. The Ziegler plant at Beuerberg, in Upper Bavaria, which was opened in 1906, is described in detail in *Engineering* of November 15. The results obtained have been eminently satisfactory, and suggest the possibility of manufacturing at a profit peat-coke and chemicals in Ireland, where from 16 feet to 40 feet of peat can be worked over large areas.

MR. GUSTAVE CANET, past-president of the French Society of Civil Engineers, has honoured the Junior Institution of Engineers by accepting the presidency, and in his inaugural address, which was delivered on November 18, he frankly and critically compared English and French practice in connection with the design and manufacture of artillery. The conditions under which gun-

makers work in the two countries are, he pointed out, essentially different. The whole tendency of French policy has been adverse to the interests of private manufacturers. In Great Britain, on the other hand, there has never been any restriction placed upon manufacturers with regard to the supply, during peace time, of war material to foreign Powers. Hence works of private manufacturers have developed and have acquired vast experience that is a valuable national asset, for they can place all their resources at the disposal of the Government in case of need.

STRIKING evidence of the reduction in working costs and in the number of unskilled coloured labourers effected by the installation of labour-saving appliances in the Transvaal mines is afforded in the paper on the equipment of the New Kleinfontein mine read by Mr. E. J. Way before the Institution of Mechanical Engineers on November 15. A branch line was constructed from the nearest railway station up to the mine, and the surface plant was equipped with a complete system of conveyors and elevators for handling all coal, ash, ore, waste rock, and residue sands, whilst the stopes underground have been provided with swinging conveyors specially designed to permit the rapid and easy dismantling and re-erection necessitated by blasting requirements and by the constant shifting of the working faces of the stopes. The actual annual reduction in the working costs due to the installation of labour-saving appliances is equivalent to a saving of nearly 3s. per ton milled.

THE Institution of Mining and Metallurgy has drawn up a series of standard weights and measures with the object of securing uniformity in scientific papers. The word "ton" shall, it is decided, represent a weight of 2000 lb. avoirdupois; the word "gallon" shall represent the Imperial gallon measure of 10 lb. of water. Temperatures shall be expressed in degrees centigrade. Returns of gold and silver shall be expressed in terms of fine gold and fine silver respectively, not as "bullion." Gold contents of ores, determined by assay, shall be expressed in money values as well as in weights; and in this connection the value shall be taken (as a convenient constant) at 85s. per troy ounce of fine gold. The adoption of these definitions in assay returns will doubtless obviate much of the existing confusion, but it is to be feared that the use of the new ton of 2000 lb. would, in the case of statistics of mineral production, not be so convenient as the statute ton of 2240 lb. or the metric ton of 2204 lb., both of which may legally be employed.

IN the *Transactions* of the Institution of Engineers and Shipbuilders in Scotland, Dr. Victor Cremieu describes his proposed apparatus for extinguishing the rolling of ships, some references to which have appeared in the daily Press. One method involves the use of a heavy sphere rolling in viscous liquid in a curved tube at the bottom of the ship; in the second form the moving weight takes the form of a pendulum swinging in a chamber in the form of a sector of a circle, again filled with viscous liquid. The paper contains no reference to what would happen in the event of the weight striking the boundaries of the chamber in a heavy sea or in a disaster.

IN the *Rendiconto* of the Naples Academy (Mathematical and Physical Section), xiii., 3 and 4, Profs. F. Bassani and C. Chistoni direct attention to a recently formed orifice in the Solfatara of Pozzuoli. This opening was first seen on February 2, and the authors consider that it affords an excellent opportunity for the study of geophysical problems connected with the changes of level of the well-known temple of Serapis. They propose that a series of observ-

ations should be undertaken at once under the control of the department of geophysics of the University of Naples pending the formation of the geophysical institution which is to be established at Pozzuoli, and that Government assistance should be asked for the necessary means of carrying on the temporary researches rendered urgent by the present eruption. Prof. Bassani, in conjunction with Dr. A. Galdieri, describes further observations on the windows broken at Ottajano during the eruption of Vesuvius of 1906, and maintains their view, which has been doubted by other writers, that the damage was done by lapilli driven against the windows by the action of wind.

"The Climate of Abbassia, near Cairo," is the title of No. 3 of the useful Survey Department papers now being issued by the Egyptian Ministry of Finance. The observatory at Abbassia was founded by the Khedive Ismail Pasha in 1868, and was removed to Helwan in 1903. Summaries of the observations have been issued from time to time, except for the five years before the removal; the present report contains a careful discussion, by Mr. B. F. E. Keeling, of the results of those five years and summaries of the mean values for the whole thirty-five years. The mean annual temperature was $70^{\circ}2$; January, $54^{\circ}1$; July, $83^{\circ}5$; the absolute extremes, $117^{\circ}1$ (August, 1881) and $28^{\circ}4$ (February, 1880). Rainfall is very small; the mean for seventeen years was only 1.18 inches; from June to September, inclusive, no rain falls. There are about 3100 hours of bright sunshine annually, not far from double the average amount in the south of England. Series of charts show the mean annual and daily curves for each of the principal elements.

We have recently had an opportunity of inspecting and testing the binocular diffraction spectroscope patented and sold by Dr. Marshall Watts, and have found it to be a remarkably efficient instrument for the spectroscopic investigation of light-sources of definite form, such as vacuum tubes. It consists of an ordinary good field-glass having attached in front of each object-glass a transparent diffraction grating mounted on optically worked plane glass. In examining a luminous vacuum tube we found that the bright lines apparently stood out in relief, whilst the illumination, even in the second and third orders, was very satisfactory. The first-order spectrum of Capella, on by no means a perfect night, was seen as quite a bright colour band. For the examination of broader light-sources, such as flames or arcs, a metal or ebonite plate with a slit in it may be usefully employed in order to obtain a purer spectrum. The price of the binocular spectroscope is 3*l.* 3*s.*, and further details of the instrument may be obtained from Dr. Watts, "Shirley," Venner Road, Sydenham.

The fortieth anniversary of the existence of the German Chemical Society was celebrated recently in Berlin. We learn from the *Times* that the meeting was devoted to retrospective addresses on important achievements of chemistry during the last forty years. Prof. Nernst delivered an address on physical chemistry; Prof. Landolt spoke on the development of inorganic chemistry; Prof. Graebe described the successes of the chemistry of the carbon compounds by the process of synthetical combinations; and Prof. Otto N. Witt, who discussed the development of technical chemistry, remarked that technical chemistry has brought about a revolution in productive industry mainly by the aid of electrotechnical science. Prof. Witt directed attention to the manufacture of cellulose from wood leading to the changed methods in the production of paper, to the employment of nitro-cellulose for the preparation of

silk-like substances for weaving, to the synthetic production of indigo and alizarin, and to the fixation of atmospheric nitrogen.

The current number of the *Oxford and Cambridge Review*, the second issue, contains two articles dealing with scientific subjects. Mr. J. Butler Burke contributes an article on "Hæckel and Hæckelism," and the headmaster of Eton College, under the title "More about Biometry," tells of the introduction of the system of anthropometric measurement of the boys at Eton, and refers to this movement as "a united act of faith in the desirability of knowledge for its own sake."

A SECOND edition, which has been revised and enlarged, of "The Practice of Soft Cheesemaking: a Guide to the Manufacture of Soft Cheese and Preparation of Cream for Market," by Messrs. C. W. Walker-Tisdale and Theodore R. Robinson, has been published by Mr. John North at the office of the *Dairy World and British Dairy Farmer*. The characteristics of the book were described in a review of the first edition which appeared in *NATURE* for June 9, 1904 (vol. lxx., p. 137). The practice of making soft cheese is increasing in this country, and this new edition of a useful book should assist small holders endeavouring to gain a livelihood from the land.

OUR ASTRONOMICAL COLUMN.

MERCURY AS A MORNING STAR.—Although the present elongation of Mercury—the planet was at greatest western elongation ($20^{\circ} 20'$) at 2h. on Sunday last—is not so favourable for the naked-eye observation of the planet as those which took place in February and August respectively, there is a possibility that during the next day or two observers may be able to pick up this elusive object near the eastern horizon just before dawn. On December 6 the planet will rise at 5h. 57m. a.m., the sun at 7h. 51m., whilst on December 8 the respective times will be 6h. 4m. and 7h. 54m.

At this season of the year an object near the horizon is not easy to find, and the would-be observer would do well to learn beforehand the exact rising point, and then

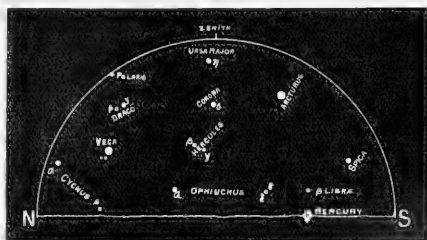

Relative positions of Mercury and bright stars at 6 a.m. December 6; observer facing due east.

to get into such a position that the horizon thereabouts is quite free. The planet rises a little less than 30° S. of E., and this direction may be noted, and in some way marked, on the previous evening, by observing the rise of Sirius, which takes place in the same azimuth at about 9 p.m. β Libræ rises about an hour before Mercury at a point some 15° nearer the east point.

The accompanying rough sketch-map may assist the observer to locate the planet. It is intended to show the approximate position of the stars, with the observer facing due east, at the time that Mercury rises, the stars being shown here as projected on to a plane parallel to the plane of the meridian.

A BRIGHT METEOR.—An exceptionally bright meteor was observed by Mr. T. F. Connolly, at South Kensington, at

11h. 30m. p.m. on November 27. The commencement of the flight was estimated to lie half-way between a Cygni and ζ Ursæ Majoris, and after pursuing a vertical path the meteor died away before reaching the horizon. The colour of the object was yellow, its shape that of a pear, a round head followed by a tapering tail. The meteor travelled slowly, and no persistent trail was observed.

SATURN'S RINGS.—A communication from Prof. Pickering to the *Astronomische Nachrichten* (No. 4216, p. 267, November 26) contains the following messages received from Prof. Lowell:—"Condensations in Saturn's rings confirmed here and measured repeatedly. They are visible symmetric and permanent. Outer situated near the outer edge, *ansa b*, inner at middle of *ansa c*. A conspicuous relative gap also detected and measured at 1.56 radius from the centre of the planet. Ring easily seen. Placed further south from shadow at west than east." This message was dated November 7, and the following was dated November 22:—"Ring shadow on Saturn bisected, black medial line, phenomenon explicable by extra-plane particles only."

THE RECENT TRANSIT OF MERCURY.—No. 21 of the *Paris Comptes rendus* (November 18) contains a number of communications regarding the observations of the transit of Mercury which took place on November 13.

At the Nice Observatory the times of the contacts were observed with several different instruments, and micrometer measurements of the polar and equatorial diameters were made. For several seconds "before" the second contact black ligaments were seen by MM. Javello and Simonin, and before third contact; the black disc of the planet was seen to be surrounded by a whitish or yellowish appearance. The measurements of the diameters are not consistent for different observers, but they all agree in making the polar diameter the shorter. M. Charlois saw very distinctly the black ligament after the second and before the third contacts, its thickness being less than the diameter of the planet. The unsteadiness of the image rendered the proposed astrophysical observations almost impossible.

At the Lyons Observatory observations of the times of contact and measurements of the diameters were also made, and none of the three observers was able to see any peculiar feature on the planet's disc.

M. Bourget, at Toulouse, found the planetary disc distinctly blacker than the nuclei of the neighbouring sun-spots, and, at intervals, suspected that it was surrounded by a slight, pale yellow border.

At Marseilles, where a number of observations of contacts and of diameters were made, M. Borrelly noted that the disc was of a dark violet colour, and appeared to be surrounded by a nebulous greyish ring of light nearly as thick as the diameter of the planet. The same observer believes he saw Mercury as a small dark disc surrounded by a violet annulus about an hour before first contact. Paying special attention to the matter, M. Esmiol was unable to discern the slightest deformation of the horns of the planet as it crossed the sun's limb at entry, but saw a sharply defined ring, of about three seconds in thickness, around the dark disc of the planet during the whole of the transit.

With the smaller magnifications at the Bourges Observatory, both the yellowish aureole and the luminous spot were seen, but Abbé Th. Moreux believes both of them to be subjective phenomena. At the beginning of the observations the bright spot was to the east of the centre, but at the end it appeared to be to the west. With a magnification of 325 it always appeared central.

Comte de la Baume Pluvinel, who had set up special spectroscopic apparatus at the Nice Observatory, was unable to find any modification of the solar spectrum near the planet's limb, although he especially examined the absorption bands of oxygen and water vapour, both visually and photographically.

Arrangements were made for observing the possible spectroscopic phenomena, visually and photographically, at the Solar Physics Observatory, South Kensington, but clouds prevented the observations being made. The planet was only seen for a few seconds some little time after the commencement of the transit, and appeared as a well-defined black disc.

SOME RECENT WORK IN PALÆONTOLOGY.

AMONG palæontological papers sent to us, the following have a faunistic bearing:—

Mr. F. R. Cowper Reed ("Memoirs of the Geological Survey of India," "Palæontologia Indica," new series, vol. ii., mem. 3, 1906) describes the lower Palæozoic fossils of the northern Shan States, Burma, and points out that we know very few fossils from pre-Devonian rocks in southern Asia. The rich finds in Burma, which have mainly become revealed through the survey by Mr. T. D. La Touche, are consequently very welcome. Dr. Bather has furnished thirty-four pages on the cystideans, and Miss Elles has assisted in the description of the graptolites, which are represented by three species of *Monograptus* (p. 90). The critical remarks on genera by Dr. Bather and Mr. Reed render the memoir of general importance. The Naungkangyi beds, which doubtless include more than one stage (p. 83), are shown to have affinities with the Lower Ordovician of northern Europe. La Touche believes the Nyaungbaung beds to be Upper Ordovician; but the fossil evidence is scanty. The Namhsin Sandstones (p. 152) are correlated with the European Wenlock. The Zebingyi beds, which contain abundant *Tentaculites elegans*, side by side with *Monograptus*, are of later age, and the fauna verges on that of the Lower Devonian of Europe; but the presence of *Monograptus* leads Mr. Reed to regard these Burmese strata as uppermost Silurian, the fauna heralding that which afterwards spread into the Mediterranean or south European province. The fine plates in the memoir are from drawings by Mr. T. A. Brock.

Dr. Carl Diener deals with the fauna of the Tropites-limestone of Byans, on the south-west flank of the Himalayas, adjoining Tibet and Nepal (*ibid.*, ser. xv., vol. v., mem. 1, 1906). The author visited the sections in 1892, and extensive collections have since been made by the Indian Geological Survey in 1899 and 1900. The cephalopod-fauna includes *Atractites*, *Orthoceras*, and a fine series of ammonites, these last furnishing 155 species out of 168 forms of all kinds known from this horizon (p. 188). This fauna is now well illustrated. We have already referred (*NATURE*, vol. lxxiv., p. 530) to the conclusion that in Byans, in one limestone band 3 feet in thickness, the dissimilar Carnic and Noric faunas of the Alps are both represented. Transitional types of ammonites are not, however, discoverable, and the apparent mingling of the faunas is held to be due to lack of sedimentation, whereby a thin stratum represents a prolonged epoch of Triassic time.

In the succeeding memoir (*ibid.*, mem. 2) Dr. Diener describes "the fauna of the Himalayan Muschelkalk." The beds are mainly of Upper Muschelkalk age, yielding numerous cephalopods. India is no longer inferior to Europe in the number of species known from this stage. Ten species of cephalopods, and three common species of brachiopods (p. 135), are identical with those of Europe.

Mr. H. Woods, working, like Mr. Cowper Reed, in Cambridge, describes the Cretaceous fauna of Pondoland for the Geological Survey of Cape Colony ("Annals of the South African Museum," vol. iv., part vii., 1906). He has also had the advantage of examining Mr. Griesbach's collection in the Hamburg Museum. The whole deposit in Pondoland is regarded by Mr. Woods as Upper Senonian. Mr. Brock must again be congratulated on the beautiful plates accompanying the memoir.

Mr. S. Tokunaga (*Journ. Coll. of Science, Univ. of Tokyo*, vol. xxi., article 2, 1906), in a paper on fossils from the environs of Tokyo, has made good use of material close to the city itself, in beds hitherto regarded as Pliocene. The fauna is almost entirely molluscan, but the author has secured from it a few remains of *Elephas antiquus*. Carefully comparing his results with those of his predecessor Brauns, who wrote in 1881, he is persuaded that the affinities with the European Crag beds have been overstated; and he brings the deposits round Tokyo forward into post-Pliocene or "Diluvial" times. The new species, and many already recorded, are figured on five large plates.

We may perhaps refer here to Mr. Schuchert's discussion of the Carboniferous and Permian beds of Russia.

India, and America (*American Journal of Science*, vol. xxii., 1906, pp. 29 and 143), since the treatment is mainly palaeontological. The conclusion arrived at is that as yet we cannot determine whether the Permian is an independent system; but hopes are expressed that the unbroken section of 9000 feet in south-western Texas, opening in Carboniferous strata, may throw important light on the true Permian sequence. The Permian faunas usually known to us are detached members of an obviously larger system, which may prove after all to be the Carboniferous.

We have received also a number of papers dealing with special divisions of fossil organic remains:—

In the Transactions of the Geological Society of South Africa, vol. ix., 1906, p. 125, Messrs. Mellor and Leslie describe the fossil forest exposed, during an unusually dry season, in the bed of the Vaal near Vereeniging. The river had etched out, as it were, the roots of trees, bedded below in coal, and a picture of a land-surface lay revealed, probably of Permian age. The authors believe that the roots and associated stems belong to *Næggerathiopsis*. Photographs are given of this interesting exposure, which may not again become visible for many years.

Fusulina, like Nummulites, has an interest for all geologists, apart from the fact that it is a handsome representative of the Foraminifera. Mr. H. Yabe (*Journ. Coll. Science, Univ. of Tokyo*, vol. xxi., article 5, 1906), in describing a Fusulina-limestone from Korea, discusses the genus in general, and adds a new subgenus, *Neoschwagerina*, to the three proposed by Schellwien, viz. *Fusulina s.s.*, *Schwagerina*, and *Dolliolina*. He corrects (p. 17) a reference to Fusulina-limestone in Borneo, originating in the *Geological Magazine* in 1875, and points out that Sumatra was the locality referred to. A useful summary of the distribution of such limestones is provided, and Brazil, Persia, Turkestan, and the Salt Range are grouped together as regions on the coast of the Carboniferous "Mediterranean Ocean" (p. 24). Our knowledge of Fusulina-limestone in Asia is still extending (see the recent discoveries in Burma, "*Records Geol. Surv. of India*," vol. xxxv., 1907, p. 52), and stratigraphers may well read Yabe's paper in connection with Schuchert's faunistic review, to which attention has been directed above. A Japanese author who writes in such good English may perhaps be excused for using "foraminifera" throughout as a singular noun.

An important criticism on the views of Prof. J. E. Duerden as to the primary hexamer character of rugose corals appears from Mr. T. C. Brown in the *American Journal of Science* for April. Brown selects *Streptelasma rectum*, one of the Devonian corals examined by Duerden, as a type, and discovers in its earliest stage a primary set of four septa, two forming a bar across the calice, the other two (alar septa) being set obliquely on the cardinal one. In the next stage a secondary septum appears in each of the comparatively large cardinal spaces, and joins the alar septum obliquely. Here, then, a pseudo-hexameral effect is temporarily produced. The author comments on Mr. R. C. Carruthers's recent paper in the *Annals and Magazine of Natural History*, which describes a similar succession of septa, but which puts forward a different view as to the mode of development of the first pair of secondary septa. We may feel sure that Prof. Duerden's work will be further stimulated by the parallel and critical investigations to which it has given rise.

Mr. Frank Springer uses the discovery of the disc of *Onychocrinus* as a basis for a complete review and a new analysis of the genera of *Crinoidea flexibilia* (*Journ. of Geology*, vol. xiv., 1906, p. 467). Drawings were made from Angelin's specimens by Mr. G. Lillievall, of Stockholm, who discovered, in the course of his work, that *Ichthyocrinus* has an extra (primitive radial) plate in the right posterior ray. Springer thereupon examined numerous specimens of this genus from other localities, and states (p. 478) that the Silurian ones agree with those drawn by Lillievall, while the Carboniferous ones have no radial. For the latter, which are regarded as showing an evolutionary elimination of a primitive character, the genus *Metichthyocrinus* is now proposed. A comparison is instituted (p. 504) between the progressive variation in position and the final removal of the radial in time,

and the similar events that affect the anal plate during the life-history of *Antedon*. The six figures illustrating the disc of *Onychocrinus* are unfortunately not numbered, and some ingenuity is required before they can be fitted in with their descriptions.

The characters of certain labyrinthodont footprints have led the Rev. Longinos Navás, S.J. (*Boletín de la Sociedad Aragonesa de Ciencias naturales*, tomo v., 1906, p. 208), to form a new species, *Chirosauros ibericus* or *Chirotherium ibericum*; but surely the reference of the beds at El Moncayo, in which the specimen occurs, to the Silurian (p. 212) rests on far too little evidence. Footprints of *Chirosauros* from Lower Triassic strata are, moreover, already known in Aragon, and are cited by our author. The fact that he is not startled by his own conclusion shows that, in his zoological studies, the successions of vertebrate forms has not as yet attracted him.

Mr. G. R. Wieland (*Science*, vol. xxiii., 1906, p. 819, and vol. xxv., 1907, p. 66) brings together good evidence on "*Dinosaurian gastroliths*." The surface of such stones, even when they are flints, shows "a higher polish than wind or water ever produces." The dinosaurs are, moreover, credited with a selective taste for brightly coloured pebbles.

In a paper on the origin of the Wasatch deposits of the Big Basin (*American Journal of Science*, vol. xxiii., 1907, p. 356), Mr. F. B. Loomis describes (p. 363) a new species of *Lambdotherium*, and one of *Glyptosaurus*, a terrestrial lizard. The fauna, which includes *Eohippus*, *Phenacodus*, *Coryphodon*, *Crocodylus*, aquatic turtles, and a few fishes, is explained as having accumulated in flood-plains, and not in a lake-basin, as has been generally asserted.

The Rev. T. Gardner, S.J., describes and illustrates several types of small stone implements formed by primitive man in Rhodesia ("*Zambesi Mission Record*," vol. iii., 1906, p. 149). The author points out that many of the specimens now found upon the surface may have been once deeply buried, and were washed out during the sudden bursts of rain. We are already familiar with the argument as to the antiquity of such implements in Africa, based on their occurrence in the river-gravels cut through by the Zambesi gorge. In Father Gardner's paper we are brought into touch with some of the first discoverers of these interesting forms, including the observant author and the scholars of St. George's School in Bulawayo.

Finally, fossil man receives a whole-hearted greeting from the Positivists, represented by Dr. Cancon, in an essay on "*Le Progrès aux Temps paléolithiques*" (*Revue positiviste internationale*, 1907). The proofs of this paper have not been very carefully corrected; but its acceptance of long ages of mental progress in man, as not incompatible with Comte's conception of human nature, will no doubt be of service in certain quarters, where science has hitherto seemed fraught with pessimism rather than with a guiding inspiration. G. A. J. C.

UNIVERSITY AND EDUCATIONAL INTELLIGENCE.

CAMBRIDGE.—Dr. Barclay-Smith has been appointed university lecturer in advanced human anatomy as from Michaelmas, 1907, until Michaelmas, 1912.

Prof. H. S. Carslaw has been approved for the degree of doctor in science.

The degree committee of the special board for mathematics is of opinion that the work submitted by J. B. Hubrecht, of Christ's College, entitled "*An Attempt at a Spectroscopic Investigation of the Solar Rotation*," is of distinction as a record of original research.

We learn from the *Revue scientifique* that the University of Lyons has accepted a gift from M. Théodore Vautier of 4000*l.*, the income from which is to be devoted to research work in experimental physics.

SIR EDWARD H. CARSON, P.C., M.P., will distribute the prizes and certificates at the Borough Polytechnic Institute on Thursday, December 12. Mr. J. Leonard Spicer,

chairman of the governing body, will take the chair at 8 p.m.

Copies of the general and departmental reports on the work of Bradford Technical College for the session 1906-7 presented to the Higher Education Subcommittee of the city have been received. The principal of the college appeals to employers of labour in the city to recognise the efforts made by those in their employ who desire to obtain instruction in evening classes, and urges masters to make arrangements to liberate students during the time the classes meet. The work of the department of textile industries is exerting a beneficial influence on the trade of Bradford. The demand for students trained in the department, and the increasing tendency of combers, spinners, and manufacturers to appeal to the college in cases of difficulty, have been very marked during the session. The reports contain other indications that the college is assisting the various industries in its neighbourhood.

At the recent annual convocation of the University of Allahabad for conferring degrees, the Vice-Chancellor, Rai Sunder Lal Bahadur, delivered an address on the need for higher technical education in the United Provinces. Referring to the conference which sat in August last at Naini Tal to consider important questions in connection with technical education, the Vice-Chancellor said, we learn from the *Pioneer Mail*, that "among the matters which engaged the attention of the conference was the suggestion for the establishment of a high-class technological institute for research and instruction, where students could receive instruction in chemical technology, mechanical engineering, and other kindred subjects. The cost of maintaining an institution like this will be large. According to Sir Norman Lockyer," continued the Vice-Chancellor, "for the up-keep of seven out of twenty-two universities, the annual sum found in Germany chiefly by the State comes up to 271,000l. When these figures are borne in mind, the cost of the proposed institute ought not to stand in the way of its establishment. Its advantages will abundantly repay the outlay. It will provide an opening for graduates in science, and will divert many of them to the useful paths of industry and research. In such an institution graduates, who have studied the general principles of science in colleges, will be able to master the various methods of the practical application of science to the needs of the present day. They will there learn with what extraordinary skill, in other and more advanced countries, men are harnessing science in the service of business and the other tasks of modern life."

The Earl of Crewe, chairman of the governing body of the Imperial College of Science and Technology, has authorised the publication of the following communication:—The governing body of the Imperial College of Science and Technology has appointed three standing committees, a finance committee (chairman, Sir Francis Mowatt), an education committee (chairman, Mr. Arthur Acland), and a general purposes committee (chairman, Lord Halsbury). In addition, two temporary committees have been appointed, namely, a transfer committee (chairman, Mr. Arthur Acland), and an organisation committee (chairman, Mr. Gerald Balfour; vice-chairman, Sir William White). Matters relating to the transfer to the Imperial College of the constituent institutions, which it has been arranged shall take effect as from January 1 next, and to the transfer of land from the Exhibition Commissioners, have been referred to the transfer committee. The organisation committee, to which have been referred matters relating to the future organisation of the Imperial College, has appointed four subcommittees to consider questions arising under this head in relation to the following sciences or groups of sciences, viz.:(1) mining and metallurgy (chairman of the subcommittee, Sir Julius Wernher); (2) other branches of engineering (chairman, Sir John Wolfe-Barry); (3) biological sciences (chairman, Sir Archibald Geikie); and (4) other pure and applied sciences (chairman, Sir Arthur Rücker). The governing body has authorised the appointment of persons not members of the governing body who are specially conversant with the sciences in question or with their in-

dustrial applications as additional members of these subcommittees, which are now engaged in considering the questions referred to them. The governing body has also approved in principle the appointment of a principal officer of the Imperial College, and has referred the question of his title and functions to the organisation committee.

SOCIETIES AND ACADEMIES.

LONDON.

Society of Chemical Industry, November 4.—Mr. R. J. Friswell in the chair.—The determination of indigotin in indigo-yielding plants: Cyril **Bergthell** and R. V. **Briggs**. The accurate determination of indigotin in the indigo plant is of considerable importance, since a correct estimate of the efficiency of the process of indigo manufacture depends thereon. A method of precipitating indigotin from an extract of the plant in boiling water by means of ammonium persulphate, proposed by Rawson in 1904 and modified by the present authors, has been shown to give correct results by comparison with those obtained by fermentation of the extract by means of the indigo enzyme (*Journ. Soc. Chem. Industry*, 1906, xxv., 729). This method has been criticised by Orchardson, Wood and Bloxam, and two alternative methods proposed, one of which, depending on the same principle, is said to give results identical with those obtained by the authors' method, whilst the other, depending on the precipitation of indirubin by the action of isatin in acid solution, indicates a considerably higher potential yield of indigotin in the plant extract used (*Journ. Soc. Chem. Industry*, xxvi., 4). The authors' original method is now verified, and some minor modifications are recommended. The conclusion that the isatin method may in certain circumstances indicate a higher indican content in a given extract than the persulphate method is not borne out by the authors' experiments.—Analysis of indigo (part iii.) and of the dried leaves of *Indigofera arrecta* and *I. Sumatrana*: R. **Gaunt**, F. **Thomas**, and W. P. **Bloxam**. A summary is first given of the results of the work on indigo carried out for the Government of India at the University of Leeds during the years 1905-7. In the present paper the exact conditions were prescribed for the preparation of pure indigotin to serve as the standard on which the tetrasulphonate process for the estimation of indigotin is based. A reply was made to certain criticisms on the tetrasulphonate process; the defects complained of were shown to be due to want of proper precaution on the part of the operators. The methods in use for the estimation of indigotin in the leaf were described. The persulphate method was found altogether faulty, as the results obtained by it were too low. The new "isatin" method was found to give much higher results, and, moreover, the method is quantitative, as proved by its action on the glucoside indican, which has recently been isolated in quantity by Messrs. A. G. Perkin and W. P. Bloxam. As a result of employing the isatin process, the indigo leaf is demonstrated to be capable of yielding more indigotin than had previously been supposed. Again, the percentage of leaf present in the green plant has been underestimated in India. It is insisted that these facts are in favour of the survival of the Indian indigo industry. Finally, it was submitted that the work on the indigo ferment or enzyme had not been properly followed out, and that the present reports on the Indian manufacture are eminently unsatisfactory, for (1) the colour-giving value of the raw materials was seriously underestimated, whilst (2) the indigotin value of the manufactured cake was overestimated, and this owing to the persistent use of unsatisfactory methods of analysis in lieu of adopting the tetrasulphonate process.

Physical Society, November 8.—Dr. C. Cree, F.R.S., vice-president, in the chair.—A freehand graphic way of determining stream surfaces and equipotentials: L. F. **Richardson**. Where an accuracy of 1 per cent. to 3 per cent. of the range is sufficient, solutions of the equation

$$\frac{\partial^2 V}{\partial x^2} + \frac{\partial^2 V}{\partial y^2} + \frac{\partial^2 V}{\partial z^2} = 0$$

may be obtained by drawing equipotentials and sections of stream surfaces, and amending them freehand until the

chequers which they form take the appropriate shape at each point of the field. The method can only be applied in certain types of symmetry, as where V is constant along each line of one or other of the following families of lines:—(1) parallel straight lines; (2) circles with their centres on a common axis and their planes normal to this axis; (3) radii from a point; (4) the normals common to the two surfaces of a thin shell of any shape; and (5) a certain family of screw-threads. It is doubtful whether there are any other possible types. Within these five types of symmetry the freehand method far surpasses analytical methods in its adaptability to boundaries and boundary conditions of almost any shape which can be drawn on paper. It can no doubt be extended to deal with conductivity which depends on position, on the potential, or on the force.—The lateral vibration of bars supported at two points with one end overhanging: **Dr. J. Morrow.** When a bar, supported at one end and at some other point in its length, vibrates under its own mass only, the expression from which the frequency can be determined is of considerable complexity. When different values are assumed for the ratio of the overhanging length to the distance between the supports, the expression reduces to a customary form with a coefficient depending on this ratio. This coefficient is given here to six figures for different ratios from zero to unity. The results show that Dunkerley's approximate values cannot be relied on to more than two figures, and that Chree's simple formula gives remarkable accuracy for cases in which the overhanging length is less than half the span.

Zoological Society, November 12.—**Dr. F. DuCane Godman, F.R.S.**, vice-president, in the chair.—Mammals collected at Beira by Mr. C. H. B. Grant, being No. 8 of the series of papers on the Rudd exploration of South Africa: **Oldfield Thomas** and **R. C. Wroughton.** Twenty-eight species were included in the collection, represented by 127 specimens, all, as before, presented to the National Museum by Mr. C. D. Rudd. The region not having been previously worked, the series was of much interest from a geographical point of view.—The feeding of serpents in captivity: **Dr. P. C. Mitchell** and **R. I. Pocock.** The different habits of python-like, non-poisonous and poisonous colubrine and viperine snakes were described, and it was stated that no evidence was found as to the existence of a specific fear of snakes in the case of any vertebrates except Primates, and that, amongst Primates, lemurs were distinguished from true monkeys by their complete indifference to snakes.—Descriptions of some new loriciarid fishes, viz. five species of Plecostomus and an Otocinclus from eastern Brazil, and two species of Arges from Colombia: **C. Tate Regan.**—Notes on Mayer's pigeon: **Lieut.-Colonel N. Manders.** The habits of this nearly extinct bird were described.—Observations on the structure of the rare Madagascar mammal, *Galidictis striata*: **F. E. Beddard.**

Institution of Mining and Metallurgy, November 21.—**Prof. W. Gowland**, president, in the chair.—The deviation of Rand bore-holes from the vertical: **J. Kitchin.** Although there are altogether 235 bore-holes sunk in the Witwatersrand area, of which forty-five have reached a depth of 3000 feet or more, the author has contented himself with a review of twenty-two only, in respect to which results sufficiently full for tabulation are available. As regards these, the general characteristics were such that he has tabulated the following ascertained effects:—(1) the bore-holes almost invariably deviate in a northerly direction; (2) they almost invariably deviate against the strata; (3) the deviation tends to be greatest when the dip is least; (4) the deviation is not confined to any particular spot or spots in the bore-holes, but seems in most cases to be more or less general throughout; and (5) there is no appreciable deviation in the case of the flat-lying surface dolomite and any amygdaloidal diabase underlying it, or in the case apparently of surface igneous rock, but in all other instances the deviation is usually marked, and its rate of increase comparatively uniform. In other words, deviation is not observed except where the rocks passed through are bedded and have a dip. The average horizontal displacement of the twenty-two bore-holes specially

submitted for analysis was 440 feet at a depth of 2000 feet, the minimum being 160 feet in a bore-hole 2000 feet deep, and the maximum 2370 feet in a bore-hole 4200 feet deep. As an appendix, the author gave particulars of a further twenty bore-holes, data of which were less detailed.—The separation of tin-oxide from wolfram: **A. Treloar** and **G. Johnson.** A record of experiments made by the authors in Cornwall upon "tinny-wolfram" with the view of saving the tin left in the product of the magnetic separator. The most successful results were obtained by taking the separated product in a dry state and boiling it in dilute sulphuric acid, which in a fairly large-scale experiment gave an extraction of 20 per cent. of tin-oxide. Hitherto, since the introduction of magnetic separation for Cornish ores, large quantities of tin-oxide have been given away in the parcels of wolfram sold, owing to a lack of means to effect this further separation from the tinny-wolfram.

PARIS.

Academy of Sciences, November 23.—**M. Henri Becquerel** in the chair.—Remarks concerning the nitrous isomerisation of isobutyl alcohol: **Louis Henry.** The conversion of the hydrochlorides of the fatty amines into alcohols by sodium nitrite results in the simple replacement of the (NH_2) group by (OH) for methylamine and ethylamine. Higher members of the series undergo a more complicated change, isomeric alcohols being produced. Isobutylamine gives isobutyl alcohol,



and trimethylcarbinol, $(CH_3)_3C.OH$, the proportion of the latter (about three-quarters) being determined by converting it into tertiary butyl chloride.—The determination of the solar elements and the masses of Mars and Jupiter by meridian observations of Vesta: **G. Loveau.** The whole of the observations made at Greenwich and Paris between the years 1807 and 1904, and numbering 5440, are utilised, and the results compared with those of **Le Verrier** and **Newcomb.**—Observation of the passage of Mercury across the sun's disc made with the Gautier equatorial (40 cm.) at the National Observatory of Athens: **D. Eginitis.** The atmospheric conditions at Athens were bad, and accurate measurements, in consequence, were impossible. The brilliant ring round the disc of Mercury observed in the transit of 1801 was not seen on this occasion.—The order of the function $D(\lambda)$ of Fredholm: **T. Laiesco.**—Some points in the theory of fundamental functions relating to certain integral equations: **Bryon Heywood.**—The irregular points of convergent series of analytical functions: **P. Montel.**—Some properties of integrals passing through a singular point of a differential equation: **H. Dulac.**—The rotatory magnetic dispersion of crystals in the neighbourhood of absorption bands: **Jean Becquerel.**—Influence of the reaction of the medium on the size of the colloidal granules: **André Mayer, G. Schaeffer, and E. Terronne.** Numerous examples are given showing that the addition of traces of acid to negative colloidal solutions, or of alkalis to positive solutions, has the effect of increasing the size of the colloidal granules.—A new compound of uranium, the tetra-iodide: **Marcel Guichard.** Metallic uranium and iodine are sealed up in a vacuum tube, the iodine being heated to $180^\circ C.$ and the uranium to $500^\circ C.$; the iodide UI_4 is thus formed. It is unstable, and readily acted upon by moisture or oxygen.—The synthesis of ammonia by catalysis, starting from its elements: **Léon Brunel** and **Paul Woog.**—A method for estimating very small quantities of zinc: **Gabriel Bertrand** and **Maurice Javillier.** The method is based upon the insolubility of calcium zincate, and allows of the separation of 0.1 mg. of zinc from three litres of solution, a dilution of 1 in 30,000,000.—Lupeol: **P. van Romburgh.** A comparison of the lupeol extracted from *breck* (the juice of *Dyera Lowii*) with that extracted from cinnamonate from the gutta-percha of *Palagium Treubii.*—Two isomeric methylspermeines: **Charles Moureu** and **Amand Valeur.** An account of two isomeric bases obtained by the decomposition of α -methylsperminium hydrate.—Experiments on the synthesis of β -campholenolactone and on the lactone of 2:4-dimethylcyclopentanol-2-acetic acid: **G. Blanc.**—The primitive form of the male fig: **Leclerc du Sablon.**—The signification of the reddening

ing ("maladie du Rouge") of the fir: L. Mangin.—A remarkable case of autonomy of the floral peduncle of the tobacco plant, caused by traumatism of the corolla: Paul Becquerel.—Contribution to the anatomical study of some textile Cyperaceae from Madagascar: P. Clavier.—Contribution to the chemical study of mistletoe, *Viscum album*: M. Leprince. An account of the method of isolating an alkaloid from this plant, 25 kilograms of the dried material giving 1.6 grams of the chlorohydrate of the base, (C₁₁H₁₁NHCl).—The physiological action of the mistletoe, *Viscum album*: René Gautier and J. Chevalier.—A new sign of true death: E. de Bourgade de la Dardye. Referring to a communication by M. Vaillant in the last number of the *Comptes rendus*, the author refers to a communication of his on the same subject published in 1868, in which the immobility of the heart, diaphragm, and intestines after death showed up clearly in radiographs.—Artificial parthenogenesis: Jacques Loeb. Criticisms of the work of M. Delage on the same subject.—The comparative morphology of *Pachydactylaria erecta* and *Suaopsis elegans*: Louis Roule.—The diagnosis of tuberculous in animals, especially in cattle, by the simultaneous use of the ophthalmic- and cutidermo-reaction: J. Lignières.—The comparison of the secretions of the two kidneys in hydradic diabetes: C. Fleig and E. Jeanbrau.—Tuberculosis cuniculi *in vivo* and antituberculous vaccination: M. Moussu.—The sterilisation of the human ovary by the X-rays: Foucaud de Courmelles.—The individualisation, graduation, and methodical localisation of the altitude cure applied to the treatment of tuberculosis: Christian Beck. The author proposes to send the patients up in groups attached to captive balloons.—The systematic position of the fossil stems known as Psaronius, Psaroniocaulon, Caulopteris: Fernand Peloude.

DIARY OF SOCIETIES.

THURSDAY, DECEMBER 5.

ROYAL SOCIETY, at 4.30.—Experiments in Optics: Prof. A. A. Michelson, For. Mem. R.S.—The Chemical Reaction of Antagonistic Muscles. Eleventh Note, Further Observations on Successive Induction: Prof. C. S. Sherrington, F.R.S.—On the Distribution of the Different Arteries supplying the Human Brain: Dr. C. E. Beevor.—Localisation of Function in the Lemnis Brain: Dr. F. W. Mott, F.R.S., and Prof. W. D. Halliburton, F.R.S.—On the Supposed Extracellular Photosynthesis of Carbon Dioxide by Chlorophyll: Prof. A. J. Ewart.—The Influence of Increased Barometric Pressure on Man, No. 4, The Relation of Age and Body Weight to Decompression Effects: L. Hill, F.R.S., and M. G. Greenwood, jun.—On the Present Distribution and Origin of the Calcareous Concretions in Coal Seams known as "Coal Balls": Miss Talbot and D. M. S. Watson.—On the Structure of *Stigillaria Scutellata*, Brongn., and other Eugillarian Stems, in Comparison with those of other Palaeozoic Lycopods: E. A. Newell Arber and H. H. Thomas.

CHEMICAL SOCIETY, at 8.30.—The Affinity Constants of Bases as Determined by Methyl Orange. Preliminary Communication: V. H. Veley.—The Velocity of Reduction of the Oxides of Lead, Cadmium, and Bismuth by Carbon Monoxide, and the Existence of the Suboxides of these Metals: F. J. Brilley.—The Relation between Unsaturation and Optical Activity, Part I., The Methyl and Boron Esters of *β*-Phenylpropionic, Cinnamic, and Phenylpropionic Acids: T. P. Hilditch.—The Constituents of the Essential Oil of Nutmeg: F. B. Power and A. H. Salway.—Methyl Ethers of some Hydroxy-antraquinones: A. G. Perkin.—The Colouring Matters of the Stilbene Group, Part IV.—The Action of Cautic Alkalies upon Paranitrolozene and its Derivatives: A. G. Green, A. H. Davies, and R. S. Horsfall.—The Replacement of Alkyl Radicals by Methyl in Substituted Ammonium Compounds: H. O. Jones and J. R. Hill.

INSTITUTION OF ELECTRICAL ENGINEERS, at 8.—Automatic Call-signalling on Locomotives: J. Figg.

CIVIL AND MECHANICAL ENGINEERS' SOCIETY, at 8.—Retaining Walls: A. T. Walmsley.

LINNEAN SOCIETY, at 8.—Report on Alcyonaria of the Sudanese Red Sea: Prof. J. Arthur Thomson.—Report on the Crinoides of the Sudanese Red Sea: H. C. Chadwick.—Notes on some Marine Algae from the Red Sea: Prof. R. J. Harvey Gibson.—Exhibitions.—Specimens of *Spartina Townsendii*, as illustrating its Distribution in Britain: Dr. Otto Stapf.—Lantern Slides showing Stages of Soil-denudation consequent on the Removal of Forests: A. P. Young.

FRIDAY, DECEMBER 6.

GEOLOGISTS' ASSOCIATION, at 8.—Notes on the Geology of the Tenby District, with Special Reference to the Carboniferous Limestone: A. L. Leach.

INSTITUTION OF CIVIL ENGINEERS, at 8.—Methods of Vaporising Liquid Fuels, used with Internal-Combustion Engines, as Applied to Road Vehicles: R. T. Deane.

MONDAY, DECEMBER 9.

ROYAL GEOGRAPHICAL SOCIETY, at 8.30.—The Jamaica Earthquake and After: Dr. Vaughan Cornish.

SOCIETY OF ARTS, at 5.—The Theory of the Microscope: Conrad Beck.

SOCIOLOGICAL SOCIETY, at 8.—The Problem of Education, a Criticism of Principles, Curricula and Methods: A. E. Crawley.

VICTORIA INSTITUTE, at 4.30.—On Primeval Man in Belgium: Rev. D. Gath Whitley.

TUESDAY, DECEMBER 10.

ZOOLOGICAL SOCIETY, at 8.30.—On the Origin of the Mammal-like Reptiles: Dr. R. Broom.—A Revision of the African Silurid Fishes of the Subfamily Clarinae: G. A. Boulenger, F.R.S.—On a Hemogregarine from the Blood of a Himalayan Lizard (*Agama tuberculata*): Prof. E. A. Minchin.

INSTITUTION OF ENGINEERS, at 8.—Arc Lighting: W. Krause.

INSTITUTION OF CIVIL ENGINEERS, at 8.—The Predetermination of Train Resistance: C. A. Carus-Wilson.

WEDNESDAY, DECEMBER 11.

SOCIETY OF ARTS, at 8.—Radio-active Phenomena: Sir William Ramsay, K.C.B., F.R.S.

THURSDAY, DECEMBER 12.

ROYAL SOCIETY, at 4.30.—*Probable Papers*: Preliminary Note on the Operational Invariants of a Binary Quantity: Major MacMahon, F.R.S.—Further Consideration of the Stability of the Pear-shaped Figure of Equilibrium of a Liquid Earth: Sir G. H. Darwin, K.C.B., F.R.S.—The Action of Ozone on Water-colour Pigments: Sir W. Abney, K.C.B., F.R.S.—On Kinetic Stability: Prof. H. Lamb, F.R.S.—The Absorption Spectra of the Vapours of Benzene and its Homologues at Different Temperatures and Pressures, and likewise of Solutions of Benzene: Prof. W. N. Hartley, F.R.S.—The Spectrum of Magnesium and of the so-called Magnesium Hydride as obtained by Spark Discharges under Reduced Pressure: E. E. Brooks.—Magnetic Declination at Kew Observatory, 1890 to 1900: Dr. C. Chree, F.R.S.—The Effects of Temperature and Pressure on the Thermal Conductivities of Solids, Part II., The Effect of Low Temperatures on the Thermal Conductivities of Pure Metals and Alloys: Prof. C. H. Lees, F.R.S.—On Exterior Ballistics, No. 2: Prof. G. Forbes, F.R.S.

SOCIETY OF ARTS, at 4.30.—Big Game in India: R. Gilbert.

FRIDAY, DECEMBER 13.

MALACOLOGICAL SOCIETY, at 8.—Additions to the Marine Molluscan Fauna of New Zealand, with Descriptions of New Species: H. Suter.—Alteration to the name of *Mitra zeyheri*, Sow. (preoccupied): G. B. Sowerby.—Descriptions of New Species of Fresh-water Shells from Central Africa: C. A. Smith.—New Land and Marine Shells from West Africa: H. B. Preston.

SOCIETY OF ARTS, at 8.—Industrial Poisons—Lead and Phosphorus—with Special Reference to the Manufacture of Lucifer Matches: Prof. T. Oliver.

PHYSICAL SOCIETY, at 7.10.—Exhibition of Electrical, Optical, and other Physical Apparatus.

ROYAL ASTRONOMICAL SOCIETY, at 5.

SATURDAY, DECEMBER 14.

ESSEX FIELD CLUB (at Essex Museum of Natural History, Stratford), at 6.—Conference on Rivers. Pollution from the Naturalist's Point of View: Opened by Prof. R. Meldola, F.R.S.

CONTENTS. PAGE

A Text-Book of Plant Physiology. By F. F. B.	97
Liquid and Gaseous Fuels	98
A Practical Handbook on Rubber. By L. C. B.	99
Our Book Shelf:—	
Jones: "School Hygiene; a Handbook for Teachers of all Grades, School Managers, &c."	99
Korschelt: "Regeneration and Transplantation"	99
Jensen: "Organische Zweckmässigkeit, Entwicklung und Vererbung von Standpunkte der Physiologie."	100
By J. B. F.	100
Letters to the Editor:—	
The Windings of Rivers. (With Diagrams).—J. Y. Buchanan, F.R.S.; J. Lomas	100
Small Flint Implements from Bungay. (Illustrated).—W. A. Dutt	102
Graphical Interpolation. (With Diagrams).—F. J. W. Whipple	103
Reflection of Polarised Light.—C. T. Whittemell	103
The Total Solar Eclipse of January 3, 1908. (Illustrated). By Dr. William J. S. Lockyer	104
New Aeroplanes. (Illustrated)	106
Anniversary Meeting of the Royal Society	107
Notes	111
Our Astronomical Column:—	
Mercury as a Morning Star. (Illustrated)	115
A Bright Meteor	115
Saturn's Rings	116
The Recent Transit of Mercury	116
Some Recent Work in Palaeontology. By G. A. J. C.	116
University and Educational Intelligence	117
Societies and Academies	118
Diary of Societies	120

THURSDAY, DECEMBER 12, 1907.

AN UPPER CRETACEOUS FLORA.

The Cretaceous Flora of Southern New York and New England. By Arthur Hollick. Pp. 219, including 40 plates. (Washington: Government Printing Office, 1906.)

THE Cretaceous flora is of extreme interest to botanists, for it was during this period that the great, and, as it appears, sudden, change took place from the ancient type of Mesozoic vegetation, with its predominant Cycadophyta and Conifers, to a flora of an essentially modern *facies*, with the Angiosperms already supreme. The recent remarkable work of Dr. Wieland (*NATURE*, vol. lxxv., p. 329; vol. lxxvi., p. 113) has intensified the interest of this transformation from the old into the new, by showing that the Cycadophyta of the earlier Mesozoic had themselves evolved a floral organisation comparable to that of an Angiosperm, indicating that the dominant groups of the two floras, different as they appear, may yet prove to have been genetically related.

Dr. Hollick's monograph relates entirely to an Upper Cretaceous flora in which Angiosperms, or at least Dicotyledons, have completely assumed the leading rôle, and little trace of their cycad-like predecessors remains. The beds yielding the fossil plants belong to the "Island Series" of Dr. Lester Ward, who thus described their distribution:—

"From Morgan (New Jersey), . . . the formation may be traced northward across Staten Island and the northern shore of Long Island, and it re-appears on Martha's Vineyard in the celebrated cliffs of Gay Head" (p. 13).

The horizon of the beds is mainly that of our Upper Chalk (Senonian), and possibly as old, in some cases, as late Cenomanian, but it is doubtful whether the intermediate Turonian is represented (p. 119). An interesting feature of the deposits is that the concretions containing the plant-remains almost always occur in glacial moraine, or in Cretaceous beds more or less disturbed by glacial action, and scarcely ever in their original positions (p. 26).

Of the 222 species to which a systematic position is assigned, six are referred to the Pteridophyta, 27 to the Gymnosperms, four to the Monocotyledons, and no less than 185 to the Dicotyledons. In spite of the many elements of doubt involved in all determinations of more or less fragmentary impressions, these figures probably give a fair though rough idea of the true proportions, and though further investigation may somewhat add to the relative importance of the Gymnosperms, there can be no doubt that the Dicotyledons had already completely gained the upper hand in the short interval, geologically speaking, since Lower Cretaceous times. The Cycadales, the characteristic plants of the earlier period, are represented by a few doubtful fragments. The fossils referred to Williamsonia by the author are, as he says, of uncertain affinity, and it has been suggested that they may rather be attributed to Magnoliaceæ, an

order which, on leaf-evidence, was largely represented in the flora.

The insignificance of the Monocotyledons is another striking point—the four fossils referred to them all seem somewhat dubious. The geological evidence, here and elsewhere, certainly weighs heavily on the side of the opinion, now widely held, that the Dicotyledons constitute the original angiospermous stock, from which the Monocotyledons have diverged.

The author's determinations are, at the present stage of investigation, necessarily based almost wholly on impressions of leaves, for such remains of flowers and fruits as have been found seldom seem to have helped materially in the identification. The botanist can rarely feel confidence in conclusions as to affinity derived from leaf-characters alone, and it is to be regretted that so many of the fossils are referred to recent genera, the evidence for such attribution being scarcely ever adequate. The author's object has apparently been to identify his specimens, generically or specifically, with those described by previous palæobotanists, rather than to determine their botanical affinities for himself. As an ample record of a rich flora the monograph has great value, especially from a stratigraphical point of view; but, as is usually the case with work on Upper Cretaceous or Tertiary plants, the data will need a far more critical treatment before any accurate botanical conclusions can be drawn.

In speaking of the coniferous remains, the author directs attention to the wide and interesting field open for future investigation in the examination of the internal structure of certain specimens. That the structure should so often be preserved is a most hopeful circumstance, and the work already done on some of this invaluable material by Prof. Jeffrey, of Harvard, partly in conjunction with the present author, shows how much may be looked for when the internal, as well as the superficial, characters of these interesting relics have been more widely investigated.

D. H. S.

PAPER MILL-WORKERS AND TECHNOLOGY.

Chapters on Paper-making. Vol. iii., Comprising a Short Practical Treatise in which Boiling, Bleaching, Loading, Colouring, and Similar Questions are discussed. Pp. viii+134; price 5s. net. Vol. iv., Containing Discussions upon Water Supplies and the Management of the Paper Machine, and its Influence upon the Qualities of Papers. Pp. vii+156; price 5s. net. By Clayton Beadle. (London: Crosby Lockwood and Son, 1907.)

THE author is one of a group of workers who aim at a progressive elevation of the standard of technological education and practice in this still very important branch of our productive industry. The paper-maker in this country has weighty reasons for preferring the "practical man" to, or before, the student of the theoretical basis of his practice. It is not the weighty reasons, however, which determine his attitude. It is the feminine quality or defect of pure prejudice; the argument is introduced *post hoc*

for its justification. The author, aware of this rule of prejudice, but encouraged by distinguished exceptions, adopts the plan of "pegging away." These volumes are the records of a scheme of higher education by correspondence. Questions directed to the elucidation of typical problems arising in the ordinary routine of the mill are set and distributed through the medium of the technical Press amongst the workers, who are invited to transmit their solutions of the problems to be criticised and corrected. A further object is to assist the workers in preparing for the more formal examination test of the City and Guilds Institute. At the same time, the questions propounded are judiciously chosen outside the formal or text-book range of the examinations syllabus of that excellent institution. We give a selection of subjects dealt with:—*Beating*, with sections on the size and speed of beater rolls, the efficiency of refining engines and edge runners; *Sizing, Colouring and Loading*, with special problems; the *Paper Machine*, with sectional treatment of dandy rolls, wire and suction boxes; the *Qualities of Papers* in relation to use, involving practical problems in "bulk," transparency, tenacity and stretch, special printing surfaces and the like.

The chapters follow one another without any attempt at a logical sequence, and each chapter comprises a selection of students' answers, also without any attempt at classification. The author's critical remarks alternate with the matter in inverted commas, and these criticisms are quite as unequal as his students' efforts. The reader is consequently confronted on each page with a species of pictorial puzzle, with the accompanying challenge to "find the policeman."

We say "policeman" taking the accepted symbol of law and order, and the student of technology is of course seeking instruction in these fundamental regulating factors of industrial processes. This defect of form, or want of form, necessarily limits the usefulness of these volumes. As a "causerie" on mill practice they will be found interesting and suggestive, but as a guide to technological instruction the matter should have been much more carefully ordered and edited. An important function of the teacher is to teach his subjects on positive, didactic lines, and the author abdicates this position in not prefacing each chapter with his own model answer to the questions propounded.

These "Chapters on Paper-making" notwithstanding constitute a most useful appeal to the latent intelligence of our mill workers.

Paper-mills are often so situated as to cut them off from tuition classes, and, further, it must not be forgotten that most workers are on night-shifts in alternate weeks, and this is a serious impediment to instruction by classes or lectures.

The author's educational work is therefore particularly deserving of encouragement, and with a little more conviction on his own part as to its solid value, he will probably see fit so to improve the form and style of subsequent "chapters" as more efficiently to supplement and complement the work of the technological institutions.

LOCAL ORNITHOLOGY.

- (1) *Bird-Life of the Borders, on Moorland and Sea, with Faunal Notes extending over Forty Years*. By Abel Chapman. Pp. xii+458; map and illustrations. (London: Gurney and Jackson, 1907.) Price 14s. net.
- (2) *The Birds of Kent*. By William J. Davis. Pp. vi+304; plate and map. (Dartford: J. and W. Davis, 1907.) Price 6s. net.
- (3) *Notes on the Birds of Rutland*. By C. Reginald Haines. Pp. xlvii+175; 8 plates and map. (London: R. H. Porter, 1907.) Price 7s. 6d. net.

(1) **I**N preparing the second edition of his pleasant and valuable account of the birds of the borders, Mr. Chapman has practically re-written on a broader basis the first section of the book, *i.e.* that relating to the Cheviots and the moorlands of the borders. The second part, which treats of the north-eastern sea-board, and, to some extent, may be considered as a treatise on the wild-fowling to be had on that coast, as well as an account of the wild-fowl to be met with there, has been merely revised.

The borderland stretching from Cheviot to the Solway comprises an area of hundreds of square miles of mountain and moor. The author defines the region covered by his observations as that mountain land which remains as it was created, unaltered by the hand of man, bounded by the line where the shepherd's crook supplants the plough; where heather and bracken, whinstone and black-faced sheep repel corn and cultivation; where grouse and blackcock yet retain their ancient domain, excluding partridge and pheasant; and where the ring-ouzel dispossesses the blackbird.

"A region largely of peat as distinguished from soil, of flowe, moss, and crag; of tumbling burns and lonely moorland, glorious in all its primeval beauty."

As on the higher fell-ranges of the borders it takes two to four acres to support each sheep; the hill country is very thinly inhabited. In this edition the author has slightly extended his purview so as to include the subjacent country, namely, the foothills which slope downwards from the higher range, "and which zone might perhaps be termed the sub-alpine region." This is the fringe of the moorland, yet it lies beyond the range of the plough, and its faunal character may be exemplified by the substitution of the blackcock, peewit, and whinchat for the red grouse, golden plover, and wheat-ear of the higher land. Here we come within the outer limit of many of the lowland woodland forms.

Beginning with the earlier months, the bird-life of the moorlands is traced in a succession of chapters throughout the year. The author having had forty years' experience of the district to which he is devotedly attached, and the book being preeminently one of personal observations, and of statements of facts, as seen by him, supplemented and expanded to some extent by theories which he felt justified in founding upon these observations, it follows that in these articles we have a very complete account of the avifauna of a district which is little known and visited.

The bird-life of the borders is constantly changing throughout the year, save, perhaps, just during the heat of the breeding season; and among all the 200 species of birds which may roughly be estimated to form its feathered population, the author finds that only fourteen are absolutely stationary.

Interspersed among the regular sequence of the chapters detailing the bird-life at different seasons, we have accounts of the game-fish, migration, grouse-shooting, and grouse-disease; and a chapter of specific bird studies dealing chiefly with some of the rarer birds met with in, or which have recently extended their range to, the district. Among the many bits of stray information there are some very pertinent remarks on the important question of heather burning and the effect upon heather of black-faced sheep, which manage, when forced by sheer necessity, to retain life in them by grubbing down into its roots.

The chapter on the process of migration advances some rather novel ideas. The author suggests, in the first place, that no one has ever seen the process of migration in actual operation, and that migratory birds seen at lightships, &c., are not in the process of migration, but at its termination, making good their landfall; and further, that the few birds one sees at sea are merely waifs and strays. He disbelieves that the journeys which small birds of little wing-power perform are accomplished in the way that is ordinarily accepted, *i.e.* by hard, straightaway flying. He says that birds can reach, high in the air, regions and conditions quite beyond human knowledge; can sustain life in rarefied atmospheres where mammals could not; and may there be able to rest without exertion, or find meteorological or atmospheric forces that mitigate or abolish the labours of ordinary flight, or possibly assist its progress. All this is very suggestive, and facts are brought forward in support of these views; but much of it must remain conjectural, of course, and extreme cold, and the stormy conditions supposed to prevail at high altitudes, would, we think, have to be considered.

In the latter part of the book the wild-fowl of the north-eastern coast, their haunts and habits, and the way to get at them with a big gun, are fully dealt with; but, unfortunately, the impracticable or inaccessible nature of their chosen haunts has left inquirers much in the dark as regards the specific distribution of the grey geese on those shores. As an account of the local habits and distribution of the border birds, this book is chiefly valuable—for the habits and the nature of the haunts of birds differ in different districts. To give one instance of this, speaking (and doubtless drawing on his observations of the bird somewhere or other) of the black-tailed godwit as a former breeding species in Britain, the author says of this country, "Nowadays there are no fens; consequently no godwits." But this is not a necessary consequence. On the Continent, this godwit is known to breed in good drained grass marshes, and its nest has been found in a dry, sandy bean-field in reclaimed lands.

The author holds strong opinions, and perhaps some of his conclusions will not be universally accepted;

possibly all the less so from his criticism of others, and a slight reluctance to accept the observations of some others as facts when they clash with his preconceived notions; and his distrust of what has not been seen by himself. But we have no more readable bird-book on our shelves, and the new edition will be welcome to those who have for years been unable to obtain the original one. Some of the author's drawings and pen-and-ink sketches are very pleasing and life-like. But with regard to the plate (not by the author) supposed to represent a coot and two Slavonian grebes in full winter dress at midsummer, we should certainly say that the heads of the grebes as drawn—the shape and size of the beak, and the white passing over and behind the eye—resemble more closely those of crested grebes in winter plumage. There is a map of the district, and a good index.

(2) Mr. Davis points out that hitherto no book dealing with the birds of the entire county of Kent has been published, although the works of Messrs. Dowker on east Kent, Prentis on the Rainham district, and the present author on Dartford and the north-west, have paved the way for a complete county avifauna. The information to be derived from these sources has now been brought together and supplemented by various records in the periodicals and notes which have been furnished by observers in various parts of the county. A short description of the eggs and nests has been given in most cases, and something about the habits of the birds which are resident in or regular visitors to the county. Unfortunately, the author's personal experience relates only to portions of the county, and the information respecting many of the birds can hardly be said to have been brought down to date.

Kent has given a name to no less than three birds on the British list, and we naturally turn to them in expectation of finding a full account of their history and present status in the county. It is therefore disappointing to find that the account of the Kentish plover consists of little more than a reprint of Mr. Farren's article in *Country Life* (most excellent in itself) on the breeding habits of this little plover; while of the Sandwich tern, discovered at the place of that name in 1784, we are merely informed that "no doubt they still breed on the Kentish coast." As to the Dartford warbler, a perusal of the four and a half pages devoted to this species, "probably more interesting to the inhabitants of the town of Dartford than any other bird," leaves us in doubt whether it is still an inhabitant of Kent or not. Half a page is filled with a quotation as to the discovery of a nest and eggs of this bird in Yorkshire; but this might well have been omitted, since the Yorkshire authorities consider the record is open to the gravest doubt, and refuse to enrol the Dartford warbler on the Yorkshire list.

We can only consider this little book as a further instalment towards the adequate avifauna of Kent which we still await. Iceland, where the chough is said to breed, must be a misprint for Ireland. The appendix includes a useful list of birds observed in east Kent during the past twenty years by Mr. H. S. D. Byron, received by the author too late for

incorporation in the text. A full index and a large map make reference to the species and localities easy.

(3) One by one the English counties are getting their bird-books, and the latest to acquire this distinction is Rutland, by far the smallest of them all. Pre-eminently an agricultural county, its natural features present nothing striking, and do not show any great diversity. Of its 100,000 acres, permanent pasture absorbs more than half; not a hundred acres are waste land or heath, and not 200 acres are water. But Mr. Haines is surely far below the mark when he states that there are scarcely 400 acres of woodland. In these circumstances he has done well in being able to give so large a list as 200 of birds which have occurred in this fruitful and profitable little bit of land. Besides the natural disabilities of Rutland as a bird resort, the historian of its ornithology has to contend with a further drawback in the almost total lack of notes bearing on the subject which date back more than a hundred years.

The one exception is to be found in the notes by Thomas Barker, of Lyndon Hall, Gilbert White's brother-in-law, and two of the earliest of these are authored by the historian of Selborne. But the notes do not amount to much, and refer chiefly to the arrival and departure, and the opening of song of less than a score of species. The most interesting of them is the wood-lark—a very rare bird now in Rutland. A slip is made in describing the gentleman who brought these notes to light as a *descendant* of Gilbert White! The later printed authorities are very few, and although a work published in 1889 is entitled "The Vertebrates of Leicestershire and Rutland," the Rutland birds are very inadequately treated therein. So that there was quite room for a new and complete work on the subject, in the preparation of which the present author has had the assistance of a large number of observers.

The general condition and character of the avifauna of the county is treated in a lucid and interesting manner in the concluding portion of the introduction, and lists are given of the species which have increased or decreased in recent years. Lists, too, are given of the resident species which are subject to some migration, and of the whole of the species actually enumerated as Rutland birds, showing their status in the county. The references made to the habits and life-histories of birds in the body of the work have been drawn from observations made in Rutland itself. The facts of most importance for British ornithologists in general to be gleaned from the pages of this handy little volume are: the eighth instance of the occurrence of Bonaparte's gull; the unique nesting of the bee-eater; the addition of Rutland to the counties where the pied flycatcher has been seen; the recent appearance of the bearded tit in the county; the acquisition of the redshank as a nesting species; the very early return of the wryneck; and the early nesting of the corncrake and partridge. The author himself seems to feel a little doubtful about the identification of the Bonaparte's gull, and ornithologists in general will be still more so; while as for the nesting of the bee-eater, we cannot help thinking that some mistake or

confusion of specimens occurred; the confusion in which the authority for the record seemed to be about the smaller grebes (p. 163) inclines us more strongly to this view.

The plates are pleasing, though they have not all of them much to do with Rutland especially. But there is one which will puzzle most people. As the jack snipe, the principal figure in it, is cut all to pieces by the shot which has apparently been fired, and is obviously dead in the air, we cannot see why the picture should be called "A Narrow Escape"; unless the title refers to the dog, which does not appear to have been hit! We have, however, seen a plate in another book which has a striking resemblance to this one, but there it has another and more appropriate title. A good index and a map complete this nicely got up little volume.

ELECTRICAL ENGINEERING.

- (1) *A Text-book of Electrical Engineering*. By Dr. Adolf Thomälen; translated from the German by G. W. O. Howe. Pp. viii+456. (London: Edward Arnold, 1907.) Price 15s. net.
- (2) *The Elements of Electrical Engineering*. By Profs. W. S. Franklin and Wm. Esty. Vol. i. Direct-Current Machines, Electric Distribution and Lighting. Pp. xiii+517. (New York: The Macmillan Company; London: Macmillan and Co., Ltd., 1906.) Price 18s. 6d. net.

(1) THIS book is an English translation of the second edition of the "Kurze Lehrbuch der Elektrotechnik," and includes some additional matter which will be introduced into the third edition. It is intended to meet the needs of electrical engineering students who have passed the most elementary stages and are taking a second- and third-year course at the technical colleges.

It is not easy to give a satisfactory definition of electrical engineering, but in default of a better it may be suggested that the subject should comprise the generation, distribution and utilisation of electric energy. This may be interpreted narrowly or broadly according to the judgment of the individual. If this be accepted as a reasonable definition, the book before us is by no means comprehensive enough to be justly called "a text-book of electrical engineering"; it should rather be called "an introduction to the theory of dynamo design." Distribution of electric energy is not considered at all, and its utilisation only in so far as the theories of motors, direct and alternating current, are concerned. The theories of direct-current feeders, of switchgear for controlling generators and motors, of electric traction apparatus, are not abstruse, and a knowledge of these matters is likely to be more useful to the average engineer than the theory of dynamo machinery.

Recognising, however, the limitations of the subject-matter, the book may be safely recommended for what it contains, although it is surprising that there should have been much difficulty in finding books already in existence covering the same range, as stated in the preface. As a brief indication of the

contents it may be stated that the first five chapters deal with fundamental principles of electricity and magnetism, the next four with the theory of direct-current dynamos and motors; these are followed by a single chapter on alternating-current theory, a chapter on transformers, four chapters on alternating-current generators and synchronous motors, and four chapters on induction motors. The book concludes with a few pages devoted to rotary converters, and an appendix on the symbolic method of treating vectors.

The matter is well arranged and clearly set forth. Considerable space is taken up by the various types of direct-current armature windings, illustrated by several good diagrams, and the important question of sparking receives proper attention.

The treatment of alternating-current generators is good, but it seems questionable whether students should be taught to look upon the magnetising current in the field windings of an alternator as a vector quantity. With this exception the section devoted to the behaviour of such machines on loads with various power factors is excellent, and the discussion of parallel running is particularly clear. Induction motors are considered in the light of the semicircle diagram with a good deal of theoretical elaboration, and single-phase commutator motors are mentioned briefly.

Taken as a whole, the book will probably strike electrical engineers as being somewhat too theoretical. It does not claim to go beyond the principles of the subject, leaving aside altogether constructional details. There are, however, many items of information which could be given without any trouble, and which would give a greater reality to the student's ideas. Thus, for instance, it seems a pity that a budding electrical engineer should arrive at the end of the book without ever having been told, that electrical apparatus must satisfy the requirements of a temperature specification. There should be no need for a man to go through a course of dynamo design to learn this elementary but important fact.

A word of praise may be given to the translator, who has done his work with marked success; it is sufficient to say that the book does not read like a translation from the German, and all who have done such work will agree that this is high praise.

(2) This is another book for the use of students, but it is intended not only for those taking a special electrical course, but also for others studying general engineering. With this object in view, the authors have endeavoured to differentiate between the two classes of readers, by giving in appendices and in several special sections in small type what they call the more elaborate developments of the subject. This seems a good plan, and it is well carried out.

The authors are professors in Lehigh University, and the book, in consequence, caters especially for the American engineer. Apart from this, the present volume may be thoroughly recommended to students in this country, on account of the practical nature of the information contained therein. For example, the authors are not content with tracing through the preliminary theory of the direct-current generator and then leaving the subject at that point, as so many

English text-books do, but they go on to discuss what limits the output of a generator in actual practice, and give a chapter on ratings and guarantees. As a whole, the book is far more in touch with practical conditions than the usual examples of this class of literature.

The present volume is confined to the study of direct currents, their generation, distribution, and utilisation for lighting. The first part is devoted to elementary theory, the theory of dynamo machines, the practical aspect of such machinery, including its rating and performance guarantees, its control by switchgear, and its operation alone and in conjunction with storage batteries. The second half contains chapters on distribution and wiring, on photometry and electric lighting, and four appendices on the magnetisation of iron, on characteristic curves, on armature windings, and on problems illustrating the contents of the whole volume.

The book will no doubt serve its particular purpose admirably, but so far as this country is concerned it is unfortunate that the slight differences between English and American practice are sufficient to deter many students from purchasing a book of considerable value in its own country.

OUR BOOK SHELF.

Modern Lithology, illustrated and defined, for the use of University, Technical, and Civil-Service Students. By E. H. Adye. Pp. 128. (Edinburgh and London: W. and A. K. Johnston, Ltd., 1907.) Price 10s. net.

THE excellent microscopic drawings of rock-sections previously issued by Mr. Adye (see NATURE, vol. lxxi., p. 341), in a work entitled "The Twentieth Century Atlas of Petrography," prepare us for the present series of sixteen smaller plates. With four coloured figures on each, some of them subdivided into two semicircles, we have a wide range of rocks accurately and artistically represented. The drawing and description of thin sections is not strictly "lithology," however "modern" it may be; but Mr. Adye deals with the illustrations clearly in the accompanying text. He also gives a glossary of petrographic terms, which contains many useful references to original papers.

The definitions of the crystallographic systems are, as often happens in elementary books, far too limited, and would exclude copper pyrites, for example, from the tetragonal system, and hemimorphite from the orthorhombic. If, moreover, rhombohedral and hexagonal are to be taken as synonymous, as stated on p. 97, there is no place under the definition given for such common minerals as quartz and calcite. A crystallographic "pyramid" (p. 111) cannot nowadays be regarded as a closed form. The glossary, as a whole, however, is a mine of information, and every geologist may read it with advantage. "Tachylite," here and on p. 18, should be "tachylite"; but this correction has been made again and again without result in geological literature. Few misprints occur; we notice "Jan- netez," "Boricky," "Radanthal," and *Galionella*.

There is no strict arrangement in the subjects on the plates, and, as we have hinted, no attempt has been made at writing on lithology in the broad sense. But the book, with its complete index, is a really good companion for those who require guidance in studying the characters presented by thin sections. No small

work has hitherto given us so effective a series of coloured petrographic illustrations. We are thus not quite sure about the description of the pyroxene-andesite from Bohemia on plate v., because the drawing so closely resembles the rock of Tichlowitz, with its brown hornblende in the groundmass, its monoclinic pyroxene, and its patches of zeolites as the only pale constituents. Again and again we could name the locality of the rock selected from the accurate details of the illustration; and when we turn to the descriptive text, we find very little room for criticism. G. A. J. C.

Inflammation. An Introduction to the Study of Pathology. Being the reprint (revised and enlarged) of an article in Prof. Allbutt's "System of Medicine." By Prof. J. George Adami. Pp. xvi+240. (London: Macmillan and Co., Ltd., 1907.) Price 5s. net.

REPRINTS in book form of articles appearing in larger volumes are not always desirable, but in the present instance so much has been added to the matter as virtually to constitute a new work. We congratulate Prof. Adami heartily on the successful issue of an arduous task; no one knows how difficult until he attempts to write on inflammation. The subject of inflammation, forming, as it does, the fundamental basis of pathology, and it might be said also of the science and practice of medicine, is beset with difficulties. The literature on it is voluminous and bewildering, and pathologists owe a debt of gratitude to Prof. Adami for having the courage to attack it. The matter is divided into sections; the first gives a general survey of the inflammatory process, the second deals with the various factors of the process—the part played by the leucocytes, the exudate, the blood-vessels, the nervous system, cells of the part, and the temperature changes; the third section deals with general considerations, and includes a chapter on the principles of treatment of the inflammatory state. Every statement made is based on published work, to which the reference is appended (and the book therefore forms a valuable bibliography on the subject of inflammation), and critical additions and summaries are liberally interspersed. The book is well and sufficiently illustrated, and no student of pathology can do without it. R. T. HEWLETT.

Notes on Maritime Meteorology. By Commander M. W. Campbell Hepworth, C.B. Pp. viii+90; 7 plates. (London: George Philip and Son, Ltd., 1907.) Price 2s. 6d. net.

THIS work consists of papers contributed to societies and institutions between 1883 and 1900, compiled while the author was on active service afloat. Two of them, occupying nearly half the book, are of a more general nature than the rest, and deal with meteorology as a factor in naval warfare and with the value of meteorological observations at sea. The author contends that, given two opposing fleets equal in all respects, "the victory in a series of engagements shall be to the fleet in the direction of whose movements meteorology shall have given the greatest aid," and some striking instances are cited of the value of weather knowledge. The other papers are of a more special character, and relate chiefly to the navigation of the Indian and Pacific oceans. Taken in connection with the useful charts dealing with the marine meteorology of those oceans published by the Admiralty and the Meteorological Office, the results of investigations by so experienced a seaman and so keen an observer as the author of the work in question will be of great interest and value to those now afloat.

LETTERS TO THE EDITOR.

[The Editor does not hold himself responsible for opinions expressed by his correspondents. Neither can he undertake to return, or to correspond with the writers of, rejected manuscripts intended for this or any other part of NATURE. No notice is taken of anonymous communications.]

Mu'attos.

MR. H. G. WELLS, in his interesting book "The Future in America" (1906), tells (pp. 269-270) a story at second-hand which apparently, however, he accepts as accurate in perfect good faith. I transcribe the facts as they were given to him:—

"A few years ago a young fellow came to Boston from New Orleans. Looked all right. Dark—but he explained that by an Italian grandmother. Touch of French in him too. Popular. Well, he made advances to a Boston girl—good family. Gave a fairly straight account of himself. Married."

The offspring of the marriage was a son:—
"Black as your hat. Absolutely negroid. Projecting jaw, thick lips, frizzy hair, flat nose—everything."

In this case Mr. Wells observes:—"The taint in the blood surges up so powerfully as to blacken the child at birth beyond even the habit of the pure-blooded negro."

This is, at any rate, ultra-Mendelian. Such a story would hardly be told and repeated unless it corresponded to popular belief. What one would like to have is precise evidence that such cases actually occur. If verifiable, it would be of great importance both on scientific and political grounds. I find, however, nothing resembling it in such authorities as I am able to consult. No such case is mentioned by either Darwin or Delage, though neither would have been likely to pass over such a striking instance of reversion had it been known to him. Sir William Lawrence, in his "Lectures on Physiology, Zoology, and the Natural History of Man" (1822), a book still worth consulting, has industriously collected (pp. 472-484) all the facts available at the time about mulattos, but has no instance of the kind.

The problem involved is thus stated by Galton ("Natural Inheritance," p. 13):—"A solitary peculiarity that blended freely with the characteristics of the parent stock, would disappear in hereditary transmission." He then discusses the case of a European mating in a black population:—"If the whiteness refused to blend with the blackness, some of the offspring of the white man would be wholly white and the rest wholly black. The same event would occur in the grandchildren, mostly, but not exclusively, in the children of the white offspring, and so on in subsequent generations. Therefore, unless the white stock became wholly extinct, some undiluted specimens of it would make their appearance during an indefinite time, giving it repeated chances of holding its own in the struggle for existence." *Mutatis mutandis*, the same law would hold for a black mating in a white population.

Lawrence quotes a single case (p. 279) in which a refusal to blend certainly existed:—"A negress had twins by an Englishman: one was perfectly black, with short, woolly curled hair; the other was light, with long hair." He also points out that in "mixed breeds" "children may be seen like their grandfathers, and unlike the father and mother," a fact observed by Lucretius.

"Fit quoque, ut interdum similes existere avorum Possint, et referant proavorum saepe figuras."

On the other hand, according to Lawrence, there was a legal process in the Spanish colonies of South America by which a mulatto could claim a declaration that he was, at any rate politically, free from any taint of black blood. Of Quinterons, who were one-sixteenth black, he says:—"It is not credible that any trace of mixed origin can remain in this case," and even of Terceerons, who were one-quarter black, "in colour and habit of body they cannot be distinguished from their European progenitors." He says (p. 274) that Jamaica Quadroons "are not to be distinguished from whites." But "there is still a contamination of dark blood, although no longer visible. It is said to betray itself sometimes in a relic of the peculiar strong smell of the great-grandmother." If these statements can be relied upon, Galton's hypothetical law does not appear

to apply to mulattos, and some doubt is thrown on the case cited by Wells. On the other hand, Lawrence quotes from the Philosophical Transactions ("v., 55") a case of two negroes who had a white child, the paternal grandfather being white. This seems purely Mendelian.

November 25. W. T. THISELTON-DYER.

Specific Stability and Mutation.

The desire to be as brief as possible has led, I fear, to some obscurity in the sentences quoted by Sir William Thiselton-Dyer (p. 77) from my letter of October 17. The meaning will perhaps be clearer if I explain the precise significance which I attached to the words "appear" and "occurrence."

By the occurrence of a mutation in one of the higher plants I meant the production of a seed capable of germination and containing an embryo with definitely different potentialities from those of its parent. The appearance of a mutation, on the other hand, implies that such a seed has germinated and given rise to a plant recognisably different from other members of the species. My contention is that the conditions of cultivation are such as to allow of the safe germination and growth of plants which would have no chance of survival under natural conditions. It is therefore possible that mutations may occur as frequently under natural conditions as under cultivation. This being so, it does not appear to me to be an abuse of language to state that the assumption that cultivation causes the occurrence of mutations is one which requires proof. In support of this assumption Sir William Thiselton-Dyer brings forward certain evidence. With much of this evidence I was already familiar, but it did not appear to me to amount to satisfactory proof of the current position. The authority of eminent breeders is quoted for the fact that, as soon as one new variety of a cultivated species has been obtained, a host of others immediately follow. But the explanation of this may be that the breeder, as soon as he has obtained a single novelty, immediately crosses it—deliberately or by accident—with the original type, thus giving rise to endless new combinations. R. H. LOCK.

Botany School, Cambridge, December 2.

THAT mutations inevitably appear sooner or later under cultural conditions is not an assumption, but a fact. That they do so only casually under natural conditions, and usually fail to perpetuate themselves, equally seems to me not an assumption, but a fact. If, as Mr. Lock seems to argue, there is an equal chance of their occurrence in either case, then their appearance should be more frequent in nature than in cultivation, because the former has a larger population to work with. But it is not so. I therefore conclude with Darwin that cultivation introduces some provocative condition which is lacking (or latent) in nature. What that condition is seems to me a very important subject for research.

December 5. W. T. THISELTON-DYER.

The Winding of Rivers.

WITH your permission I would like to make a few remarks on the winding of rivers, which is at present being discussed in your pages. My observations were made while fishing, and my remarks refer to the rivers of our own country, and may not apply to rivers of greater volume. But first I would like to point out an objection to Prof. J. Thomson's experiments. In Prof. Thomson's paper in the report of the British Association for 1876 no details of the conditions of the experiment are given, but Sir Oliver Lodge in his letter (NATURE, November 28) says Prof. Thomson's model had a wooden bed. Now it is very evident that we must be careful in drawing conclusions from experiments made under these conditions. That wooden bed, however carefully made, would not be of the shape that nature would have given it, and any deviation from nature's shape would cause unnatural currents. It, however, does seem probable that something of the nature of Prof. Thomson's diagonal under-tow will exist even in river-shaped beds.

The whole question of the flow of water in river beds is extremely complicated. This is evidenced by the contrary

results of the observations of your correspondents. But little consideration is sufficient to show that this must be so; the variables are so many. We have, for instance, variations in the curvature of the bend, in the velocity of the water, and in the formation of the bed of the river, which we must remember is dug out and shaped by flood water for flood water, and is but little altered as the river falls in volume. Take, for instance, the case supposed to be represented by Prof. Thomson's model. Here, with a certain curvature and a certain velocity of flow, we can easily imagine the formation of the diagonal under-tow. But if we were to increase the velocity of the flow this cross under-current would decrease and ultimately cease, and when a certain relation of velocity to curvature was arrived at we would get the conditions referred to in Mr. R. D. Oldham's letter in NATURE of November 21, where he says:—"Sand and even pebbles may be thrown up to the surface of the water near the outer bank of the stream, and where the waters have overflowed the banks pebbles may be found lying on the dry ground after the flood has passed away."

In most of the rivers I know which flow in gravel beds, where they are constantly cutting away their banks, the main flow is more sinuous at low level than when in flood. At low level the main stream runs into the pools at the bends on the deep or concave bank, and as the deep sides of the successive pools are on opposite banks of the river, the stream has to cross its bed between the successive pools. While in flood the swiftest flowing part, on the surface at least, is near midstream, but the formation of the bed at the place and the flow above and below may alter this in some cases. After the flood has fallen, the river bed it has shaped has an infinite variety of forms at different places, and the flow of the water at any part must be studied with reference to that particular part, and to the part above which has determined the cross-section and velocity of the water coming to it, and also to the formation of the part below which determines its escape.

There is one very common type of flow which frequently presents itself in varying forms in rivers which alter considerably in volume from time to time. After the flood has fallen the river becomes, so to speak, divided into streams and pools. Over the shallows the water runs rapidly, while in the pools it moves slowly and somewhat irregularly. The streams coming into the pools flow next the concave banks, and come into the pools with some velocity, which is soon lost in the slower movements in the pools. The streams thus lose their kinetic energy, which is converted into potential energy, raising the level of the water at the place where the stream loses its velocity. From this part of the pool, in addition to the stream flowing down the pool, a reverse current is started which flows back on the inner side of the pool, flowing to the upper end of it, where it curves round and flows downwards alongside the main stream. Part of the back current is no doubt due to the inflowing main current causing an induced current, but it seems to be mainly due to the loss of kinetic energy of the stream, causing a rise of the level of the water where its velocity is destroyed.

As to the cutting and wearing away of the banks of rivers, that is mainly the result of eddies formed by the flowing water meeting with obstructions, such as stones, tree roots and stems, inequalities in the banks, &c., or even by water impinging on water. One of the deepest pools in a river I observed was entirely dug out of its gravel bed by eddies produced by the main river meeting a large tributary stream at right angles and mingling their waters in turbulent eddies; and it seems probable that the excavation of the deep pools generally found at the foot of waterfalls have been greatly aided by the eddies formed by the falling water meeting the quieter water of the pools.

The common practice in this country of protecting the banks of rivers by means of little piers or "tooks" to throw the water off them, and into the middle of the bed of the stream, generally results in failure, because the piers cause eddies, and deep pools endangering the banks are frequently dug out by these eddies; and while these piers tend to throw the water to the other side of the channel, yet the sloping bed throws it back and causes it to strike

the bank below the pier, thus in some cases making matters worse. The only place I know of where a knowledge of the bad effects of eddies on river banks has been put in practice is in the river Adda, which drains Lake Como, Italy. There the irregularities of the banks seem to have been smoothed to some extent, and then simply paved with small cobble stones a few inches in diameter. Over this the water flows without eddies, and the banks, so far as one could see, gave little trouble, though one would imagine that if a break in this rather weak surface took place destruction might be rapid.

JOHN AITKEN.

Ardenlea, Falkirk, December 3.

May Gorsedd.

IN my communication to NATURE, May 2 (vol. lxxvi., p. 9), I stated that there was another plan of a Gorsedd among the Iolo MSS. at Llanover. The important difference between it and the plan published in that number is the omission of the solstitial stones. It is a May-November Gorsedd pure and simple, based on the equinox, and for that reason very interesting. Both plans are truer to ancient tradition than the present plan favoured by the bards. The present orientation is exclusively solstitial, against the best traditions in point. In the older plans the May-year is given the preeminence in one, and is the only year given in the other. In both the older plans the circle consists of nineteen stones, leaving open a splayed avenue on the east, the breadth of which corresponds to the sun's course from August to November and from February to May. Though the present plan of a circle of twelve stones at equal distance from each other is antiquarianly sound, one may regard the older plans as still sounder. I have elsewhere shown that the exclusively solstitial arrangement of the stones in the present plan is about the only point in connection with the bardic Gorsedd of doubtful antiquity.

The accompanying tracing (Fig. 1), for which I am indebted to Mr. T. H. Thomas, shows how the original plan was rather carelessly drawn, just the kind of diagram which an old bard would draw to accompany a written description, as in this case, for the benefit probably of an engraver.

In the formal and authentic bardic records very little is said about the significance of the various features of the Gorsedd circle. There is no dabbling in archaeology.



FIG. 1.—Iolo's May Gorsedd.

It is enough for the bard to be able to say that everything he records is sanctioned by immemorial custom.

In the second quarter of the last century a bard arose who claimed also to be a chief bard or archdruid, having the bardic name "Myvyr Morgannwg." He attempted a scientific and philosophical interpretation of the Gorsedd. He insisted upon the absolute identity of the bardic institution with the circles of the Stone Age. He made several successful hits at the truth about the Gorsedd, but wild speculations and irrelevant matter have made his various writings hardly readable.

NO. 1989, VOL. 77]

The accompanying diagram (Fig. 2) represents Myvyr's idea of the "most essential elements of the Gorsedd," and is reproduced from one of his controversial pamphlets. It describes a May-November Gorsedd, but with the solstitial signs, except that Virgo is fixed at the equinox. The diagram is true to the best type, but the interpretation is a misfit. It is a forcible illustration of the disturbing effect of a solstitial cult upon sound May-year tradition.

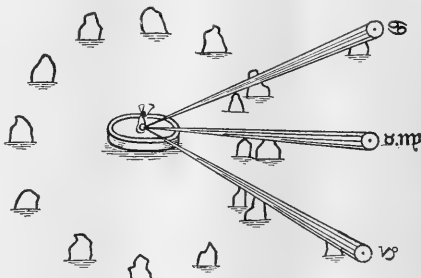

FIG. 2.—Myvyr's May Gorsedd.

Myvyr has also brought his fancy to play on the central stone. A mannikin, holding up something like a bow and arrow, occupies the place of the chief bard, and the three rays look very much like three clubs. Myvyr has nothing to say about the only valuable feature of his Gorsedd, namely, the May-November alignments.

JOHN GRIFFITH.

A FISHING TRIP TO THE GULF OF MEXICO.¹

MR. AFLALO describes a journey to Florida *via* New York, a fortnight's tarpon and other fishing in Florida, and the journey home by way of sundry Central American and West Indian ports. The account given by the author of his outward journey differs in no material respect from numerous extant accounts of similar journeys, but is somewhat marred by a style rather reminiscent of that of the traveller who has performed to provide his daily or weekly quota of copy for some periodical publication. Such sentences as "In the middle of the ship soft-voiced stewardesses gently raise thick curtains and say that dinner will be up in a minute. It usually is. Fore and aft there is neither curtain nor stewardess, but one sufferer leans across a neighbour of a different race and obeys the irresistible. Everything comes up, even the moon at last . . ." are hardly worthy of a serious volume. There are, however, interesting if slight allusions to and photographs of the Bronx Park Zoological Gardens and New York Aquarium, and a good account of a typical American health and pleasure resort in North Carolina.

Coming as it does from so well-known an authority on sea-fishing as Mr. Aflalo, the second section of the book is naturally by far the most interesting. The account given of tarpon fishing as pursued at Boca Grande is both full and lucid; a sufficiency of detail as to gear, methods of using it, and expenses is given without any needless discursiveness or undue brevity. The whole circumstances of the sport are brought clearly before the reader; the string of boats, each with its armchair fixed athwartships for the angler, towed out to the fishing grounds by a launch in the morning; the fish gaffed long ere they are played to a finish in the fisherman's eagerness to get back to the grounds and kill a larger one; the annoyance resulting

¹ "Sunshine and Sport in Florida and the West India." By F. G. Aflalo. Pp. xv + 272. (London: T. Werner Laurie, n.d.)

from hooking anything that is not a tarpon, and the homeward journey to the scales, where the fish are weighed and wasted, for, unlike its Asiatic congener, the tarpon is never used for food. Notwithstanding that we are told that luck and brute force count for far more than skill in tarpon fishing, it is curious what a fascination the sport has for its votaries; there is something beyond the surroundings and beyond the huge size and strength of the fish itself (for these latter, great as they are, become insignificant when compared with the power and bulk of the great serranids and sharks, which are but "vermin" to the tarpon fisher) that lends a glamour to the sport. It is curious to find the same author between the same covers dazzled by this glamour, and yet talking of "the semi-artificial sport of deer 'forests' (*sic*)," setting the armchair and brute force of the tarpon fisher higher than the rough hillsides, patience, and skill of the deer-stalker.

wish to visit the West Indies, and holds out some hope that Jamaica may hereafter find prosperity as a resort for British tourists.

It only remains to add that the printing and appearance of the book are good, and that an excellent index is provided. The book is well illustrated from photographs, and we are enabled by the kindness of the publisher to reproduce an illustration of the New York Aquarium, showing how an old fort has been adapted for this use; the open tanks built into the floor for the reception of large fishes are well shown in the picture, and present a feature which would seem worthy of imitation on this side of the Atlantic.

L. W. B.

GREEK ARCHAEOLOGY.

THE articles in the latest volume of the "Annual of the British School at Athens" which are of most importance are those by Mr. R. C. Bosan-

quet, the late director of the School, and his assistants, which describe their excavations in the temple and precinct of the goddess Artemis Orthia at Sparta. Thus, for the first time for some years, the main interest of the School's work is transferred from things "Mycenaean" or "Minoan" to antiquities of the "classical" period. The excavations of the School at Palaikastro, in Crete, which have produced so many interesting monuments of the older civilisation of Greece, have been brought to an end (Mr. Dawkins describes the last flicker of this work last year in the present volume), and a totally different surroundings, and productive of totally different results, has been wisely chosen. This is as it should be. Eventually the present phase of the school's work will also exhaust itself, and then, all in good time, the attention of the school will no doubt again be turned towards Mycenaean matters. Dr. Arthur Evans will by that time have published his great book on Knossos, the Italian results will also be published, and we can start afresh with renewed interest and increased knowledge, derived from the complete study of the results of the previous period of excavation. Then the school will, it is to be hoped, complete the great



Transformation of an old fort into the New York Aquarium. From "Sunshine and Sport in Florida and the West Indies."

A chapter in this otherwise interesting section of the book devoted to speculations upon the early life-history of the tarpon is marred by the author's preliminary assumption that *Megalops* is a "herring," an assumption the more surprising when it appears from other passages in the book that he is well acquainted with one, if not both, of its real allies, *Elops* and *Albula*. Perhaps, however, in the case of one who does not claim to write as a scientific ichthyologist, such an assumption may be pardoned, as may his want of knowledge of Gill's paper (Smithsonian Miscellaneous Collections, 1005) dealing with the early histories of *Megalops* and its allies, and epitomising our existing knowledge of the singular metamorphosis passed through by the young of these fishes.

The concluding section of the book contains some useful suggestions for the sea-fisherman who may

new scene of labour, amid a totally different surroundings, and productive of totally different results, has been wisely chosen. This is as it should be. Eventually the present phase of the school's work will also exhaust itself, and then, all in good time, the attention of the school will no doubt again be turned towards Mycenaean matters. Dr. Arthur Evans will by that time have published his great book on Knossos, the Italian results will also be published, and we can start afresh with renewed interest and increased knowledge, derived from the complete study of the results of the previous period of excavation. Then the school will, it is to be hoped, complete the great

"The Annual of the British School at Athens," xii. Pp. vi+523; 12 plates; and illustrations in text. (London: Macmillan and Co., Ltd., 1905-6.) Price 25s. net.

work of excavation at Phylakopi, in Melos, which remains unfinished. Meanwhile, the Mycenaologists can discuss the results of the energetic exploring work of the last decade, and books such as Prof. Burrows's recently published "Discoveries in Crete," or articles like that of Dr. Mackenzie on "Cretan Palaces and the Ægean Civilisation," which appears in this volume, will help us to understand these results better.

Dr. Mackenzie's article continues his discussion of the contingent results of the excavations at Knossos and Phaistos, which commenced in last year's "Annual." In the continuation he passes from architectural evidence to a discussion of various theories as to the origins of Ægean culture, in which



FIG. 1.—Cretan seal-impression, showing Minoan civil and military costume; waistcloth and armour. From the "Annual of the British School at Athens."

he rightly criticises and dismisses the revived Carian theory of Dr. Dörpfeld, and urges his own view and that of Dr. Evans, which is shared by many others, apparently by Prof. Burrows, and certainly by myself (see King and Hall, "Egypt and Western Asia in the Light of Recent Discovery," p. 128), that the Ægean civilisation came from Africa, and was akin in origin to that of Egypt. I mention that this view is held by me, because Dr. Mackenzie credits me in his article with believing rather that Ægean culture came from Asia. He says:—"The designations 'kleinasiatisch' and Asianic, as well as other statements in the passage cited (*Journ. Hell.*

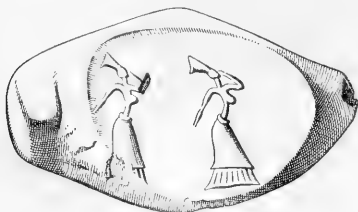

FIG. 2.—Cretan seal-impression, showing Minoan female costume; skirt developed from waistcloth. From the "Annual of the British School at Athens."

Stud., xxv., 323) would seem to indicate an underlying belief on Mr. Hall's part that the primary movement of the Ægeo-Pelasgian people was from an initial centre of departure somewhere in Asia." But, as a matter of fact, I agree entirely with Dr. Mackenzie. The words "kleinasiatisch" and Asianic have been used by me in reference to the pre-Hellenic languages of the Ægean merely because they are so used by the philologists Kretschmer and Fick; and their sole reason for using such terms is that the only later representatives of these languages which are at all well known were spoken in Asia Minor.

Prof. Fick may regard these tongues as being of Asiatic origin. Dr. Mackenzie says:—"Even Fick continues to behold one last vestige of the same oriental mirage. The initial racial movement which led to the Ægeo-Pelasgian culture would, according to Fick, have to be assigned a starting-point at some centre in Asia beyond the Hittite country." But I do not, and I think I may reasonably protest against having non-existent "underlying beliefs" assigned to me, in view of the following passage in the same article that Dr. Mackenzie quotes (*J.H.S.*, xxv., p. 337), the meaning of which seems to me perfectly clear:—"If we were to suppose that the prehistoric Greek and the Egyptian civilisations had a common origin back in the darkness of the Age of Stone, that they were twin cultures of the same Mediterranean stock, the one having developed, however, amid the diverse isles and changing seas and skies of the Ægean, the other on the monotonous banks of the Nile, we can see how

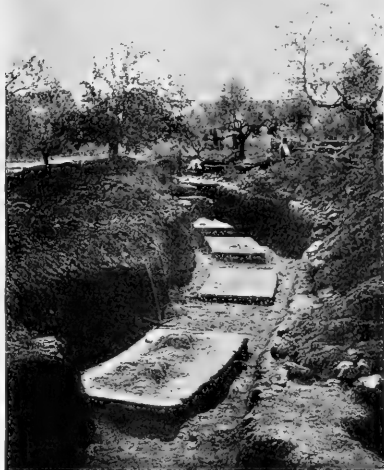

FIG. 3.—The Excavations at Sparta; piers of the Roman theatre built in the court of the sanctuary of Artemis Orthia. From the "Annual of the British School at Athens."

the northern culture would naturally show greater freedom and variety, often running off into mere bizzarerie, but as often exhibiting something of that spirit which we, knowing it in the resuscitated Aryanised civilisation of the later day, call 'Greek.'

From this I think it is clear that I do not believe in an Asiatic origin for the Ægean culture, and that I do believe in an African origin for it is shown by the passage, already referred to, in Mr. King's and my book (originally published in 1905 as the final volume of an American series), in which I say:—"... We are gradually being led to perceive the possibility that the Minoan culture of Greece was in its origin an offshoot from that of primeval Egypt, probably in early Neolithic times." One of the things that has always disposed both others and me to believe an African origin for it is the scanty costume worn by the Mycenaans, which has a decidedly southern appearance. Dr. Mackenzie is perhaps the first to direct attention to this point in print, and

rightly insists upon its importance, elaborating it at length in this article. On the other hand, we must not forget that such a south-to-north migration, from a warmer to a colder climate, is an unusual proceeding in the history of mankind.

Returning to the excavations at Sparta, we see from the articles dealing with them how important this phase of the school's work is proving to be. The identification of the site and discovery of the remains of the temple of Artemis Orthia, where the well-known Spartan flagellation of the boys took place in honour of the goddess, is a great feather in the caps of Prof. Bosanquet, Mr. Dawkins, and their assistants. The discovery of a regular stratum of early votive offerings, chiefly archaic bronzes of the Olympia type, but in some ways more interesting than those, is an important event, as it adds considerably to our knowledge of archaic Greek art, especially in that peculiarly inartistic and philistine place, Sparta; and the many inscriptions of Roman date throw light, not only on the flagellation ceremony, but generally on the course of life in Roman Sparta. In publishing these inscriptions, Mr. H. J. W. Tillyard insists in every case on adding a Latin translation, which is perfectly unnecessary, and savours of scholastic pedantry. If we are to have translations, let them be in English if the commentary is English.

We are unable to devote more space to the discussion of the Spartan discoveries, owing to the claims to notice of much other interesting matter in this volume of the "Annual." Also, it is perhaps best to postpone further comment until next year, when the work will have been further advanced.

Of these other articles, all are of interest and many of importance, with the exception of a note on "Boats on the Euphrates and Tigris," which seems hardly appropriate to the "Annual of the British School at Athens," and contains no new information; we have known all about *keleks*, *shahtirs* and *kifas*, and have compared them with Herodotus, i., 194, since the days of Rawlinson and Layard.

Of the other articles, perhaps Mr. Droop's and Mr. Dickinson's are the most "geistreich." Mr. Droop on Cretan geometric pottery is illuminating, and Mr. Dickinson's article on "Damophon of Messene" is an example of good archaeological criticism, on which the author may be congratulated. The travel articles by Messrs. Dawkins, Wace, Hasluck and others are interesting, as usual, and we welcome a contribution by a native Cretan archaeologist, Dr. Xanthoudides, who speaks our language, and, apparently, writes it as well. Finally, Mr. Traquair contributes to our knowledge of the deeply interesting period of the Frankish domination in the Morea, with an article on the mediæval fortresses of Laconia, which will interest heralds as well as archaeologists. H. R. HALL.

THE FUTURE WATER SUPPLY OF LONDON.

IN an interesting paper on "London's First Conduit System," just published in the Transactions of the London and Middlesex Archaeological Society, Dr. A. Morley Davies gives an account of the lines of pipes which were laid in the thirteenth and succeeding centuries to carry water to London from springs in the gravel at Paddington, Marylebone, and other rural districts. At a later date, to meet the growing wants of London, the great engineering effort of the New River was undertaken, and later still deep wells were driven into the chalk, and the Thames was tapped above Teddington Weir by several private companies. The unification of the London

waterworks under one comprehensive and representative Board which bought out the old companies is so recent that it is almost surprising to find how soon the organisation of the Board has been perfected and its members set free to consider the tremendous problem of the future water supply of London.

A good many years ago much was heard of the necessity for obtaining a totally new supply of water for London from a pure and distant source which should be beyond the suspicion of impurity and capable of supplying the highest parts of the metropolitan area by gravitation. The sentimental argument that the water companies pumping from the Thames and Lee had to purify a raw material which has sometimes been described as "diluted sewage" is one which cannot fail to appeal to the imagination of every water-drinker, despite the reassuring result of the supreme test—the death-rate of London. But the restrictive activity of the Thames Conservancy and the discovery of the remarkable action on raw water of storage and thorough filtration have robbed the argument of its old force, while the exhaustive bacteriological examination of the raw and filtered water by Dr. Houston and his staff in the Metropolitan Water Board's laboratory has satisfied even those who heartily dislike lowland rivers as a source of water supply that the safeguards in the case of London are adequate to ensure purity.

The sufficiency of the supply is another matter, and on this point the Water Board, after prolonged discussion at two meetings, came to a decision as to their future policy on December 6. The Works and Stores Committee prepared a careful report reviewing the situation which, after amendment, was adopted. The whole subject of London water supply had been gone into by two Royal Commissions in recent years, one under Lord Balfour of Burleigh in 1802, the other under Lord Llandaff in 1897, and the committee's report does not repeat the details elicited by those inquiries. It is noted, however, that the average daily supply to London in 1881 was 143,821,000 gallons, or 33.20 gallons per head for a population of 4,331,600, while in 1906-7 the average daily supply was 225,000,000 gallons, or 32.84 gallons per head for a population of 6,851,000. Of the present daily supply of 225,000,000 gallons, 57 per cent. comes from the Thames, and the remainder in nearly equal proportions from the Lee and from wells or springs, the actual figures being:—

	1906-7	Maximum
From the Thames	128,842,695 ...	300,000,000
" Lee	44,150,290 ...	52,500,000
" wells in Lee Valley, Kent, &c.	51,355,797 ...	67,500,000
" Hanworth gravel beds ...	564,008 ...	—
" Hampstead and Highgate ponds	87,893 ...	—
Total	225,000,683	420,000,000

The maximum column gives the figures which the Balfour Commission held to be the greatest average daily yield of the whole district.

The total amount of water which the Board can abstract from the Thames in existing conditions is 228,500,000 gallons per day, and even this amount cannot be obtained until additional storage reservoirs have been constructed. The maximum supply to be relied upon from sources other than the Thames is estimated by the chief engineer to the Water Board at 120,000,000 gallons per day, the total available being thus 348,500,000 gallons per day.

It is estimated that by 1941 the population to be supplied by the Board will be 12,000,000, and in 1960 16,286,000, and, assuming a consumption of thirty-five gallons per head, this means 420,000,000

gallons in 1941, and 570,000,000 gallons in 1960. Of the various sources of supply, that from the Thames alone is capable of considerable expansion, and in 1960 it is estimated that 450,000,000 gallons per day may be taken from that river. In order to admit of this expansion, immense storage reservoirs would require to be constructed; the amount of storage necessary in 1916 would be 6,436,000,000 gallons, in 1941 as much as 27,276,000,000 gallons, and in 1960 the prodigious amount of 54,059,000,000 gallons, the necessary storage increasing at a greater rate than the supply. The chief engineer believes that 450,000,000 gallons is the limit which could be taken economically from the Thames in any conditions.

The works at present in existence or authorised will suffice for the supply of London until 1917, and to provide the additional works required at that date it will be necessary to approach Parliament for new powers in 1910. The new scheme which has been definitely adopted as the policy of the board is to develop the supply from the Thames valley, and to trust to that as sufficient for the next fifty years, but at the same time to acquire powers for securing a supplemental source of supply to be utilised when the existing sources can no longer be developed economically. In the report as issued reference is merely made to "a distant source" being necessary fifty years hence, but in the debate the source was referred to plainly as Wales. It is remembered that before the creation of the Metropolitan Water Board the London County Council as water authority developed a scheme for supplying London with water from Wales in competition with the companies, and it was proposed in the debate on the report before the Water Board to proceed forthwith with a Welsh scheme, but a very large majority agreed to endorse the recommendations of the report in this particular. The three important resolutions as amended in another particular and adopted are as follows:—

"(a) That in the opinion of the Board it is desirable to seek Parliamentary powers enabling them to provide additional supplies from the Thames for as long a period as is economically practicable.

"(b) That as the increase in population will eventually render resort to some other source than the Thames watershed imperative, the Board view with great alarm the increasing tendency of authorities throughout the kingdom to appropriate water-supplying areas for their particular use, and in these circumstances desire to urge upon Parliament the necessity for regulating the appropriation of water-supplying areas, so that the needs of the metropolises as well as of other populous places may receive due consideration.

"That a copy of the foregoing resolution be sent to the President of the Local Government Board, and that he be asked to receive a deputation from the Board on the subject; and further, that in the event of such request being granted, the Works and Stores Committee be authorised to make all necessary arrangements with regard to the deputation.

"(c) That it be an instruction to the Works and Stores Committee to prepare and submit to the Board as early as practicable a scheme to give effect to the foregoing resolutions."

The Metropolitan Water Board is the largest and most important water authority in the United Kingdom, being responsible for the supply to one-sixth of the population of the British Isles. The distribution of rainfall, on which water supply depends immediately or ultimately, is, speaking broadly, the inverse of the distribution of population. Taking the part of England and Wales south of the Trent, it may be said that most people live in the Thames valley, while most rain falls in Wales. Much rain falls also on Dartmoor, Exmoor, and in the Lake District,

all of them distant and unpeopled places on which the eyes of nearer populations have been turned for some time. It is the custom of Governments to assume control of the distribution of natural treasure and to regulate the pegging-out of claims for hewing out gold or diamonds, and the Water Board now proposes to ask for the extension of this principle to the drawing of water for great communities. The suggestion is not new, but it will none the less meet with keen opposition, for the large towns with great and distant water supplies are usually permitted and sometimes compelled by Parliament to sell surplus water to the communities along the track of their aqueducts, and hence municipal foresight may involve taking thought also for possible interference with spheres of interest.

It is interesting to compare the proposed appeal to Government to keep a place in the struggle for water-yielding grounds for the supply of London half a century hence with the arguments employed by Mr. Urquhart A. Forbes in a paper on "The Water Supply of the United Kingdom" in the October number of the *Quarterly Review*. Mr. Forbes urges the appointment of a central water board for the country with subordinate watershed boards in order to check the depredations of the great towns on the upper reaches of rivers, and to ensure the maintenance of the lower streams in a condition fit for navigation and fishing. It must not be forgotten that rivers not only water the land, but drain it as well, and to the mind detached from all municipal or commercial schemes it appears self-evident that the same channel should not be required to act both as an aqueduct and as a sewer. On the other hand, it is an acknowledged fact that the insertion of a properly proportioned artificial lake in the upper waters of a river benefits that river by checking floods in wet weather and maintaining a good flow in dry weather, while it enables a permanent and pure supply to be drawn for the uses of a distant population. To the scientific mind the surprising thing is that steps have not been taken long ago to gauge the flow of all the rivers in the country and to establish rain gauges in remote and uninhabited places where the treasure of the heavens descends in fullest amount. Not until this has been done can the alliterative dictum of Mr. John Burns—"Rain to the rivers, sewage to the sea"—become an effective mandate.

NOTES.

THE Nobel prizes, of the value of nearly 7700*l.* each, were presented at the Academy of Sciences at Stockholm on Tuesday. In science, the prizes were awarded as follows:—physics, Prof. Michelson, University of Chicago; chemistry, Prof. Buchner, University of Berlin; medicine, Dr. Laveran, Pasteur Institute, Paris.

THE Glasgow Corporation has decided to confer the freedom of the city on Lord Lister.

A TELEGRAM from Largs states that Lord Kelvin has not been well for more than a fortnight, and has been confined to his bed. His condition on Tuesday night had improved.

MR. J. D. ROCKEFELLER has just given an additional sum of more than 520,000*l.* to the Rockefeller Institute for Medical Research in New York, to be held as an endowment the income of which is to be used at the discretion of the management.

THE death is reported, in his seventy-ninth year, of Dr. Asaph Hall, professor of astronomy at Harvard since 1895. Prof. Hall received an elementary-school education in his

boyhood, and worked for some time at farming and carpentry. In 1857 he became an assistant at Harvard Observatory, which he left in 1862 to enter the service of the Naval Observatory of the United States.

AN International Congress of Low Temperature Industries will be held at Paris for the first time in June, 1908. The general effects of low temperatures and their use in connection with food, horticulture, mines, metallurgy, commerce, and transport are to be discussed. Full particulars may be obtained from the secretary to the congress, 10 rue Poisson, Paris.

DR. J. COSSAR EWART, F.R.S., commenced a course of twelve Swiney lectures on geology in connection with the British Museum (Natural History) on Friday last, December 6. The subject of the lectures, which are being delivered on Mondays, Fridays, and Saturdays, at 5 p.m., in the lecture theatre of the Victoria and Albert Museum, South Kensington, is "Horses of the Past and Present." The lecture to-morrow (Friday) will be on the fossil horses of Central Europe compared with Prjvzvalsky's horse. Admission to the course is free.

THE Duke of Argyll, honorary president of the Franco-British Exhibition, the Earl of Derby, president, the vice-presidents, and the executive and finance committees are this afternoon giving a reception in the exhibition grounds, to be followed by an inspection of the progress of the works.

The annual conversazione of the Royal College of Science and Royal School of Mines will be held in the new buildings of the college on Wednesday next, December 18. Many interesting exhibits will be shown in the various departments, and Mr. G. S. Newth will deliver a popular lecture on "Coal-mine Explosions."

THE annual meeting of the British Science Guild will be held at the Mansion House on Wednesday, January 15, at 4.15 p.m. The Lord Mayor has consented to preside and to become one of the vice-presidents of the Guild. Mr. Haldane, the president of the Guild, and other gentlemen will address the meeting. Steps are being taken by the Guild to bring the proposals for legislation for the prevention of the pollution of rivers before many societies and local bodies.

WE are requested to make it known that a meeting will be held under the auspices of the Essex Field Club on Saturday, December 14, at the Essex Museum, Stratford, for the discussion of rivers' pollution from the naturalist's point of view. The subject will be opened by Prof. Meldola, F.R.S., and spoken to by Sir William Ramsay, K.C.B., F.R.S., Mr. E. B. Barnard, M.P., Sir Alexander Pedler, F.R.S., Mr. William Whitaker, F.R.S., Dr. Thresh, and other gentlemen well acquainted with the question of water supply. All interested in the matter are invited to attend. Mr. W. Cole, Buckhurst Hill, Essex, will be glad to send cards.

A PROPOSAL made to the Public Control Committee of the London County Council by Signor D. Maggiora to apply the process of discharging cannon of special construction, known in Austria as weather shooting, "to prevent the formation of fog or to disperse it in case it is already formed, and also to disperse and destroy all clouds, and to prevent rain, hailstorms, lightning, and thunder," has been under the consideration of the Council. It was referred to the director of the Meteorological Office for report. The proposal is even more ambitious in its scope than its predecessors of more or less similar character

in other countries of the old or new world. As might be expected, Dr. Shaw's report, based largely upon Prof. Pernster's article in the *Meteorologische Zeitschrift* of March last, and on official reports of the Vienna Meteorological Office, is entirely unfavourable, and the County Council has therefore not been asked to vote money for the proposed experiments.

THE Brent Valley Bird Sanctuary consists of a wood, nineteen acres in extent, which comes into the London postal district. About eighty species of birds have been seen in or near the enclosure, while nearly half that number are known to have bred within it; and for four years a number of members of the Selborne Society and other lovers of natural history have with their own hands maintained the fences and brought them into a state of greater efficiency, or have contributed towards the wages of temporary watchers. Much more should be done, and the committee has therefore made an appeal for annual subscriptions from people who are interested in birds, so that a permanent custodian may be appointed. Subscriptions should be sent to Mrs. Webb, Odstock, Hanwell, W., honorary secretary of the committee and of the Brent Valley branch of the Selborne Society.

At a meeting of the epidemiological section of the Royal Society of Medicine on December 2, papers were contributed by Dr. Haffkine, on the present methods of combating plague, and Dr. Ashburton Thompson, of Sydney, N.S.W., on protection of India from invasion by plague. Dr. Haffkine considers that the following propositions are now more or less generally recognised, viz. that (1) plague is what has been termed, in a general sense, a disease of locality; (2) it is contracted principally at night; and (3) the part which man plays as direct agent in its propagation is a more or less subordinate one. After discussing such measures as desertion of the locality, disinfection, and rat destruction, the conclusion was arrived at that the ultimate method of combating the bubonic plague in the areas in which it becomes endemic is that of conferring on the population immunity from the disease by means of an artificial treatment. Dr. Ashburton Thompson, in his paper, said the fundamental data acquired in the investigations at Sydney are that (1) the epidemic spread of plague occurs independently of communication of the infection from the sick, consequently the infection of plague spreads by means which are external to man; (2) the plague-rat is harmless to man, but is, nevertheless, the essential cause of epidemics; and (3) the intermediate agent between rat and man (and between rat and rat) is the flea. The infection of man is most usually contingent on his being within buildings together with plague-rats.

WE learn from the *Lancet* that Prof. Alfonso Sella, professor of experimental physics in the Royal University of Rome, died on November 25 at forty years of age. From an interesting obituary notice by the Italian correspondent of our contemporary, we extract the following particulars of Prof. Sella's scientific career. Prof. Sella inherited from his father, Quintino Sella, one of Italy's greatest statesmen, a love of science, abstract and applied, which carried him with special distinction through the mathematical and physical curriculum of the University of Turin. Like his sire he took his annual holiday in the Alps, where, in his seventeenth year, he was the first to scale the summit of the Dent-du-Midi; and he found another pastime in aeronautic adventure, a field in which he had many followers, in conjunction with whom he founded the "Società Aeronautica Italiana." For the ten years

between 1889 and 1899 he acted as assistant to the Senator Pietro Blaserna in the Roman "Istituto Fisico," after which he was made professor extraordinary of experimental physics in the University. From that post, after a year's success in the class-room and the laboratory, he was promoted ordinary professor of the same subject, giving also post-graduate instruction (the so-called "Corso di Perfezionamento") to those students who were to make pure and applied physics the business of their lives. His scientific papers, read and discussed before various scientific congresses and societies, were numerous and important, always rich in independent speculation and research. Among these may be mentioned his study on "L'Influenza dei Raggi Röntgen e della Luce Ultra-Violetta sulle Scintille" and his "Ricerche sulla Radio-attività dell'Aria." To him, in concert with Guglielmo Romiti, professor of anatomy and embryology in the University of Pisa, Italy owes her "Association for the Advancement of Science," organised on British lines and convened for the first time in September last at Parma, where it achieved a gratifying success. A committee, composed of Profs. Blaserna, Cerruti, Reina, Volterra, and Tonelli, the Rector of the University, is taking steps to place a memorial of Prof. Sella in the Istituto Fisico in the form of a bust in marble. Subscriptions should be sent to Prof. Reina at the school of applied engineering of the University.

THE second annual general meeting of the National League for Physical Education and Improvement was held on December 6 under the presidency of the Bishop of Ripon. The report of the executive council stated, in regard to the medical inspection of school children, that it will be possible, now a medical department has been established, to advise the Board of Education that under efficient supervision and control the best uniform system may prevail and be carried out under conditions sufficiently elastic to suit the requirements of different districts. The knowledge and experience gained in other countries are sure to have important results in their bearing upon the work of the league. On the question of pure milk, a joint committee of the league and the National Health Society, on which were members of the Infants' Health Society and other similar organisations, the Royal Commission on Tuberculosis, and the Royal Veterinary College, has now been formed, and has drawn up a preliminary report, in which it is recommended that the periodical veterinary inspection of all cows, the milk of which is being offered for sale for human consumption, should be made compulsory throughout the United Kingdom. The Milk Committee is now preparing recommendations with regard to milking and handling, transport and distribution.

AN account of an expedition in the Himalayas, which included the first ascent of Trisul (23,406 feet), has been given to Reuter's representative by Dr. T. H. Longstaff. The party consisted of Major C. G. Bruce, Mr. A. L. Mumm (late hon. secretary to the Alpine Club), Dr. Longstaff, and guides. Originally the object of the journey was to attempt the ascent of Mount Everest from the Tibetan side, but for political reasons this was found to be impossible. It was decided to go to the central Himalayas, to Garhwal, and from that point attempt Trisul. After two marches along the Trisul glacier the party started up the snow slopes of the mountain on June 7, and that evening reached a height of 20,000 feet. During this period Dr. Longstaff had by far the worst experience in his foreign travels. On the third day the party descended to the foot of the mountain, and again camped at 11,600 feet. On June 11 Dr. Longstaff and his guides marched rapidly round his old track, camping the same afternoon

at a height of 17,450 feet. On the following morning the party started at 5.30 a.m., and five hours later reached its highest camp of 20,000 feet. As dangerous crevasses half covered with snow and ice were ahead, the explorers roped themselves together, and at noon reached 21,000 feet. The party now followed the narrow N.N.E. ridge of Trisul, which leads straight to the summit. At 4 p.m., after ten hours' continuous climbing, the summit was reached. The cold was so bitter that it was only possible to remain for fifteen minutes. To the west the view was one of extraordinary vastness, as the horizon extended over the whole of the lower Garhwal and the snow peaks beyond. To the north lay the Tibetan frontier, obscured by rolling masses of black cloud. To the east were the frowning cliffs of Nanda Devi and its untrodden glaciers. The party now turned its attention in the direction of the Tibetan frontier, and during July explored glaciers to the east and west of Kamet (25,450 feet), reaching on one occasion an altitude of 20,000 feet on the mountain. In August and September Dr. Longstaff explored the valleys to the south and west of Trisul, while Major Bruce and Mr. Mumm made more ascents in Kashmir.

THE report of the council of the Royal Agricultural Society, presented at the annual general meeting held on Wednesday, December 11, states that the frosty weather in the spring caused injury to white clover, broad beans, and wheat, and the wet summer and autumn led to extensive injuries by parasitic fungi. Many investigations have been made into these diseases. Another unobserved enemy to the potato, *Stylanus capitatus*, has been proved by experiment to attack the living plant. A hawthorn hedge was seriously affected by *Botrytis cinerea*. Bacterial injuries to potatoes, broad beans, and oats have been investigated. Scouring in stock was found to be due to the mould developed on the feeding cake. In the zoological department nothing of special importance was reported, except the recurrence of the pygmy mangold beetle, which is probably a more frequent and serious pest to mangold than has hitherto been supposed. With the abnormally wet summer came a large number of complaints of caterpillar attack, and in many instances the caterpillars were of species not usually seriously troublesome. Later again, certain pests generally associated with particularly dry seasons began to be complained of, as the results of the continued fine weeks of the late summer and autumn. The council, at its last meeting, considered a suggestion that the Board of Agriculture should be urged to schedule tuberculosis, and, after discussion, the following recommendation of the veterinary committee was unanimously adopted:—"That in the event of the promotion of legislation dealing with the question of tuberculosis and other diseases of cattle, the council of the Royal Agricultural Society of England is of opinion that any regulations for dealing with this question should be issued by the Board of Agriculture and not to any other department." A discussion ensued as to the desirability of forming a national representative body to safeguard, so far as possible, the interests of agriculturists in connection with any measures to be adopted for dealing with the question of tuberculosis in cattle, and it was resolved:—"That a committee be formed to communicate with other societies for the purpose of watching the interests of agriculture, in view of possible legislation with regard to the tuberculosis question." The society's show will be held at Newcastle-upon-Tyne in 1908, and at Gloucester in 1909.

THE Hon. Walter Rothschild has recently received half-a-dozen specimens of the Californian elephant-seal (*Macrorhinus leoninus angustirostris*), a race which had for some

time been regarded as extinct. The specimens were obtained from Guadalupe Island, off the coast of Lower California, and before they were shot the collector was fortunate enough to obtain several photographs of them as they lay on the beach, which consists of huge boulders of volcanic rock, some black and some white, with intervening stretches of sand. Enlargements of these photographs have been presented by Mr. Rothschild to the British Museum (Natural History). The Californian elephant-seal is somewhat smaller than the typical elephant-seal of Heard Island, the Crozets, and other islands in the southern ocean, but can scarcely be regarded as more than a local race. With the exception of a specimen destroyed in the late San Francisco fire, adult male examples of this animal have hitherto been unrepresented in museums. Two of Mr. Rothschild's specimens are being mounted for the museum at Tring by Rowland Ward, Ltd.

Among the papers in vol. lxxviii., part ii., of *Zeitschrift für wissenschaftliche Zoologie* is one by Dr. M. Nowikoff, of Heidelberg, on the dorsal sense-organs of chitons, with remarks on the structure of the shell in those molluscs. Certain tropical chitons, it will be remembered, possess eyes on the dorsal surface of the shell, but all, it appears, have a canal-system within the shell itself which is likewise sensory in function. Both the eyes and the canal-system are described in detail by the author, who also directs attention to the peculiarities presented by the fibrous layer connecting the eyes with the epidermis. The dorsal eyes are of two types, one characteristic of the subfamilies Tonicinæ and Liolophurinæ, and the other restricted to certain species of chiton itself. It is remarkable that in certain species, especially *Tonica chilensis*, the dorsal eyes are attacked, and apparently destroyed, by an alga, which develops within the substance of the shell.

The Health Committee of Liverpool has issued a report (published by C. Tinling and Co., Ltd.) on investigations undertaken by Mr. R. Newstead, of the School of Tropical Medicine, Liverpool University, on the habits, life-history, and breeding-places of the house-fly, as observed in the city. The chief breeding-places were found to be in pits for the store of stable manure, fermenting heaps of hop refuse, and ash-pits containing fermenting vegetable matter, the infection being equally as great in closed as in open receptacles. Although the ordinary disinfectants appear to be of no avail in checking the development, barn-door fowls are of great value in reducing the numbers of grubs and pupæ. The period of development (which in ordinary circumstances may last from three to five weeks) is reduced by the heat of fermentation to a minimum of ten days, and this accounts for the fact that in ash-pits emptied weekly in summer no flies are produced. The emptying of these and other receptacles for refuse at intervals of seven days in summer is therefore recommended; while, in connection with other remedial measures, attention is directed to the importance of early removal of fermentable matter from streets and other public places.

The Board of Agriculture and Fisheries has issued an order, the short title of which is the "American Gooseberry Mildew (Prohibition of Importation of Bushes) Order of 1907," under which the landing in Great Britain of any gooseberry bush or currant bush brought from any place out of Great Britain is strictly prohibited. The order also provides that if, on any examination, an inspector finds any bush which is affected with American gooseberry mildew, he is forthwith to communicate the fact to the Board, and serve on the occupier of the premises on which

the bush is found a notice prohibiting, until the notice is withdrawn by a like notice, the removal of any gooseberry or currant bush from those premises.

Among the papers in the September issue of the Proceedings of the Philadelphia Academy, reference may be made to one by Dr. H. A. Pilsbry on the barnacles of the genus *Megalasma*—a genus established on the evidence of a specimen dredged during the cruise of H.M.S. *Challenger* in the Philippine archipelago. In the author's opinion the genus should, however, be taken to include one sectional group of the numerous species hitherto included in the nearly allied *Pucilasma*.

EXTERNAL parasites infesting domesticated animals in India form the subject of a special investigation by the entomological division of the Department of Agriculture. The first results of the investigation, dealing with ticks, are published in Bulletin No. 6 of the department in question. According to the author, Mr. C. Warburton, over the greater part of India the ticks infesting domesticated animals belong for the most part to four species only. Two other species may, however, occur sporadically in some numbers, but the occurrence of any other type is so rare as to be of no economic importance. Means of identifying the six species are given in the paper.

The current number of the *Annals of Tropical Medicine and Parasitology* contains articles on a variety of matters bearing directly or indirectly on the subjects named in the title. An important memoir by Mr. J. E. Salvin-Moore and Dr. A. Breinl breaks new ground, and will excite much interest, perhaps also some controversy, amongst the many investigators of this important class of parasites. Valuable contributions upon African parasitic protozoa, and upon *Sirochaeta duttoni*, the parasite of African tick fever, are furnished by the late Dr. J. L. Dutton, Dr. J. L. Todd, Dr. E. N. Tobey, and by Dr. A. Breinl respectively. It looks at first curious to see included in this journal two almost purely zoological memoirs on Cyclopidae from the Gold Coast, by Dr. W. M. Graham and Dr. G. S. Brady, but Cyclops comes into indirect relation to tropical medicine by acting as a host for the guinea-worm. Dr. C. W. Branch writes on yaws. The contents of the journal bear testimony to the broad scientific spirit in which the Liverpool School of Tropical Medicine carries on its work.

PROF. E. DE JANCZEWSKI has rendered a service to the botanical community by the publication in vol. xxxv., part iii., of the *Mémoires de la Société de Physique et d'Histoire naturelle de Genève* of a valuable monograph on the genus *Ribes*, embellished by some excellent illustrations. It is particularly interesting to find that the author has examined numerous living specimens, and has cultivated many of the species. Six subgenera are demarcated, of which two are characterised by the production of dioecious flowers. In the subgenus *Parilla* the flowers bear sterile organs, but in the species of the subgenus *Berisia* the staminate flowers have no distinct ovary, nor do the pistillate flowers produce pollen. The chief centres of the genus are found in North America and in China, except for the species of the subgenus *Parilla*, that are almost confined to South America. Eighteen hybrids are described, most of them representing crosses between species in the same subgenus.

FOUR parts, numbered 16 to 19, of the "Materials for a Flora of the Malayan Peninsula," have been published as an extra number of vol. lxxiv. of the Journal of the Asiatic Society of Bengal. Three numbers appeared in

1905; the fourth has recently been issued. Apart from the account of the genus *Psychotria*, that concludes the Rubiaceæ, these numbers contain the orders—following the sequence of Bentham and Hooker's system—Valerianaceæ to Loganiaceæ. The authors, Sir George King and Mr. J. S. Gamble, have assumed responsibility for separate orders in addition to certain others undertaken by Colonel D. Prain. For the twenty-eight orders collated, the species amount to 686, of which 190 are new to science. The additions are numerous in the Myrsinaceæ and Sapotaceæ, notably in the genera *Ardisia* and *Bassia*, also in the genus *Diospyros*. A new genus, *Pernettyopsis*, and five species of *Rhododendron*, form an increment to the Ericaceæ. Many of the genera of the Apocynaceæ are very fully represented in Malaya, e.g. *Urceola*, *Anodendron*, and *Willughbeia*. The Sapotaceæ and Apocynaceæ are rich in rubber, gutta, and other economic species.

THREE memoirs have recently been issued by Dr. Leather, of the Agricultural Research Institute, Pusa (India). One, on the composition of Indian oil seeds, gives the percentage of oil in eleven different varieties, including cotton-seed, linseed, and others less known here. Among other interesting points, it is stated that Indian linseed contains about 40 per cent. of oil, and is consequently richer than seed grown elsewhere. Further investigations of oil seeds are much needed on account of the commercial value of the oil and the agricultural value of the residue left after extraction. In another memoir a description is given of the pot culture house at Pusa; the only novel point is the method of watering. The soils under investigation cracked and caked if water was poured direct on to the top; it was therefore allowed to diffuse out from a porous pot placed in the soil. This method is commonly employed to irrigate trees in parts of India, a porous spherical vessel being sunk in the ground near the root of the tree and kept full of water. The last memoir deals with experiments on the availability of phosphates and potash. The general result is that Dyer's citric acid method for determining phosphates is likely to be useful in examining Indian soils. This, indeed, might reasonably have been expected.

In the *Journal of the Franklin Institute* (vol. clxiv., No. 3) Dr. E. Goldsmith describes a meteoric stone which was seen to fall on April 30, 1906, on the New Jersey shore. On analysis the stone yielded 44.36 per cent. of iron, 42.80 per cent. of silica, 4.18 per cent. of alumina, 2.00 per cent. of nickel oxide, 1.90 per cent. of titanic acid, and 1.84 per cent. of carbon.

We have received from the author, Mr. J. P. Johnson, a pamphlet (Johannesburg, price 1s.) containing two short papers on the auriferous conglomerate of the Witwatersrand and on the antimony deposits of the Murchison range. The former, while containing little that is new, gives a concise review of the geology of the goldfield, and the latter contains a description of some interesting antimony ore deposits which appear to be impregnations of a bed of metamorphosed limestone. The antimony occurs as sulphide, altered at the surface into a yellow oxide and the hydroxide.

In the *Journal of the Franklin Institute* (vol. clxiv., No. 5) Mr. L. E. Levy gives an appreciative obituary notice of Prof. Angelo Heilprin, the eminent American geographer and geologist, who died on July 17. In 1876 he studied in London at the Royal School of Mines, where he gained the Edward Forbes medal. He was the author

of numerous important works, the most interesting being "The Arctic Problem" (1893), which contains the story of the Peary Relief Expedition, which he organised. He lived but fifty-four years, yet within that brief period he accomplished work that would well suffice the compass of the longest lifetime.

An important report, compiled by Miss A. M. Anderson and Dr. T. M. Legge, has been issued on dangerous and injurious processes in the coating of metal with lead, or a mixture of lead and tin. The Blue-book also contains the results of an experimental investigation into the conditions of operating tinning workshops, which has been written by Mr. G. E. Duckering, one of His Majesty's inspectors of factories, who carried out the investigation. The most important of the suggested regulations set forth in the report is that no lead shall be used in the tinning of metal hollow-ware.

THE president of the International Aeronautical Committee has sent us a summary of the places that took part in the scientific balloon ascents of July 22-27, and the heights reached, so far as at present known. This series of ascents was made in compliance with a suggestion by the recent Aeronautical Conference at Milan that a special effort should be made to obtain information regarding the conditions obtaining in the upper regions of the atmosphere on consecutive days; the results will be eventually published in detail by the Aeronautical Committee. About fifty places took part in the investigation; the extra-European ascents being at or near the Azores, Spitsbergen, Iceland, China Sea, Cairo, and the United States; at Simla unfavourable weather prevented experiments from being made. Twenty-five balloons were sent up in England and Scotland alone, and (so far as yet known) some of the balloons from Manchester reached the highest altitude attained in any of the ascents, viz. 21,500 metres. From Uccle (Brussels) a height of 21,140 metres was reached, and 20,000 metres near the Azores. We learn that nearly all the English balloons drifted to the eastward, and that the temperature records proved conclusively the existence of isothermal conditions above some 12,000 metres, thus confirming the interesting theory put forward by M. Teisserenc de Bort. We understand that similar special ascents extending over a week will probably be made next year, and that, through the efforts of Prof. Schuster, arrangements have been made by the University of Manchester for the kite station on Glossop Moor to be continued.

A CLEAR and concise statement of our present knowledge of the masses of the electrons which play so important a part in electrical phenomena was presented to the Italian Physical Society in the form of a report on the subject by Prof. Levi-Civita at the recent congress at Parma, and is published in full in the October number of *Nuovo Cimento*.

AFTER careful consideration of the various methods of determining the ratio of the electromagnetic to the electrostatic unit of electricity, Messrs. E. B. Rosa and N. E. Dorsey came to the conclusion, several years ago, that the most accurate were Maxwell's bridge method, in which a condenser rapidly charged and discharged replaces one of the resistances of a resistance bridge, and the method in which the charges or the discharges of a condenser rapidly charged and discharged are sent through one coil of a differential galvanometer, while a steady current from the charging battery is sent through the other coil. The October number of the *Bulletin of the U.S. Bureau of*

Standards contains an account of a determination they have made by the latter method, according to which the ratio for vacuo is 2.9971×10^{10} , with an uncertainty not exceeding 1 part in 10,000. It is interesting to compare this result with the most probable value of the velocity of light, which, according to M. Weinberg's recent discussion of the measurements available, appears to be in vacuo 2.9986×10^{10} , with an uncertainty not exceeding 1 part in 10,000.

A METHOD of preserving eggs by dipping them in recently boiled water at a temperature of about 110° F., then into boiling water, and afterwards into cold water, was described in an article in NATURE of November 28 (p. 84). In reply to an inquiry, the writer of the article states that the time during which the eggs are immersed in the water at 110° F. in this method should be about ten seconds.

THE Silica Syndicate, Ltd., of 82 Hatton Garden, has issued a new price-list of chemical apparatus made from transparent vitreous silica by their special process. The apparatus includes evaporating basins, beakers, crucibles, flasks, retorts, and test-tubes; the prices are about 75 per cent. lower than those ruling a year ago, and it is anticipated that as the demand grows for fused silica ware further reductions will become possible. We have had an opportunity of examining the various pieces of apparatus made by the syndicate, and have been struck by their wonderfully clear and homogeneous character as compared with that of silica ware made by other processes. They are, moreover, comparatively thin and light, a fact which makes them useful for many purposes for which coarser vessels would be unsuitable; crucibles of fused silica, for instance, can often be used in place of platinum crucibles. In spite of their thinness, the quartz vessels are very strong and tough, and much less liable to break than either ordinary or Jena glass; even if broken they do not splinter, but merely crack, so that they can easily be repaired by fusing the broken parts together. Such repairs are executed by the syndicate at a trifling cost. To those unacquainted with the properties of fused silica, the following points may be of interest. It does not crack when subjected to the most violent and sudden changes of temperature. It is not attacked by acids, with the exception of hydrofluoric acid, and is harder than ordinary glass. Its melting point is approximately that of platinum, whilst it has a coefficient of expansion of 0.0000059 per degree, that is, about one-seventeenth the value for platinum. So far as is at present known, it shows no tendency to devitrification.

A NEW catalogue of lantern-slides has been received from Mr. C. Baker, 244 High Holborn, W.C. The list contains slides suitable for the illustration of lessons or lectures on natural history, and includes many from photomicrographic negatives, as well as photographs taken from nature with an ordinary camera. Sets of slides have also been arranged to illustrate some leading books on microscopic objects.

MESSRS. J. H. DALLMEYER, LTD., inform us that they have recently appointed several new wholesale agents for their lenses and apparatus abroad. They state that British lens manufacturers, like British dry-plate manufacturers, are able to hold their own in foreign markets in face of high tariffs walls and severe competition. In the United States the duty alone amounts to 45 per cent. of the value of the goods, whilst Germany is the home of the keenest competitors of manufacturing opticians.

WE have received from Messrs. Siemens Brothers and Co., Ltd., two well-produced and conveniently arranged

catalogues. One deals with thermoelectric pyrometers and temperature indicators and recorders which can be used for all processes in which the accurate determination of temperature between the limits of about -190° C. and 1600° C. is a necessary factor. The other supplies a descriptive account, with abundant illustrations, of a great variety of electro-medical apparatus. Among these attention may be directed to the patent tantalum X-ray tubes, which can be worked with the anti-cathode at red heat, and the induction coils with variable primary windings. Medical men and others should find the clear diagrams of assistance in understanding the characteristics of the apparatus described.

MESSRS. NEWTON AND CO. have sent us a copy of a descriptive lecture on the moon, illustrated by sixty lantern slides, arranged and prepared by Mr. R. Kerr. The notes upon the characteristic points of the various slides, all of which are from Messrs. Newton's collection, will enable anyone to give an interesting reading on our satellite without possessing special knowledge of astronomy. Another pamphlet containing notes on lantern-slides, intended for purposes of popular lectures, deals with general astronomy. This pamphlet is now in its fifth edition, and has been revised and enlarged. It comprises much information of an old-fashioned type, and can scarcely be considered as representing the work and results of modern astronomy; nevertheless, many instructive notes may be extracted from it. A more careful revision of the pamphlet would have prevented such errors as:—"Of the nature of this ring [of Saturn] . . . we are not acquainted"; 1006 instead of 1066 as the date of an appearance of Halley's comet; "Mr." Huggins for Sir William Huggins; and HB instead of Hg.

OUR ASTRONOMICAL COLUMN.

PHOTOGRAPHS OF JUPITER'S SATELLITES VI. AND VII.—During the opposition of 1905-6 eighty-six photographs of Jupiter's sixth satellite were secured at the Greenwich Observatory, with the 30-inch reflector, between August 23, 1905, and February 15, 1906. Nineteen photographs of the seventh satellite were taken between October 22, 1905, and January 26, 1906. The opposition of 1906-7 was somewhat marred by bad weather, but on twenty-eight nights, spread over a period of 222 days, fifty-six photographs of the sixth satellite were obtained. Only on seven nights, during a period of eighty-seven days, were photographs of the seventh satellite secured, amounting to twelve in all. From these photographs the positions of the satellites were determined, and the results are shown graphically on two diagrams published in the Monthly Notices for November (vol. lxvii., No. 9, p. 561). The orbits of the four major satellites are shown for comparison, and the difference in the size of the orbits of the four inner and two outer satellites is very striking.

TEMPERATURE CONTROL OF SILVERED MIRRORS.—No. 122 of the Lick Observatory Bulletin contains a short paper by Dr. Heber D. Curtis on the temperature control of silvered specula. The writer discusses first the previous records of changes in the focal lengths of large specula, briefly referring to the experience of Profs. Keeler, Perrine, Hale, and Wright in this matter. He then describes a method of artificial cooling which he has tried, and found to be effective, with the 37-inch Mills reflector, which is being used by the D. O. Mills expedition to the southern hemisphere, of which he now has charge.

The large mirror has a clear aperture of 36.56 inches and a focal length of 17.46 feet, and, during his work with this instrument, Prof. Wright found that a progressive lengthening of the focal length, amounting to from fifteen to twenty-five millimetres, took place during the first four or five hours of each night's work, the drop in temperature being some 5° C. or 6° C. In the first place, Dr.

Curtis increased the ventilation apertures about the mirror so that about one-sixth of the area of the back of the mirror was directly exposed. This, apparently, had little effect, so a refrigerating machine was obtained and put into operation. The machine is of the anhydrous ammonia type, and is automatic in action. To cool the mirror the telescope is placed vertical, and a movable box brought into position to enclose the cooling pipes and the mirror end; two electric fans circulate the cooled air freely around the mirror. This operation is commenced about three hours before sunset, and when the thermometer shows a fall of 5° C. or 6° C. the case is removed, about forty minutes before sunset. No moisture forms on the silvered surface, which may be 3° C. or 4° C. below the temperature of the surrounding atmosphere when observations commence. This method has proved very successful, for focal changes are, as a rule, not noticeable, and scarcely ever exceed five millimetres. Dr. Curtis's account of his experiments also appears in the current number of the *Astrophysical Journal*, and is there illustrated by two photographs, the one showing the telescope and spectrograph, the second showing the wooden cooling chamber in position.

ORBITS OF SPECTROSCOPIC BINARIES.—From plates taken with the Mills reflector, the orbits of the spectroscopic binaries α Carinae, α Pavonis, and κ Velorum have been determined by Dr. Curtis, and their elements are published in No. 122 of the Lick Observatory Bulletins. α Carinae is a star of magnitude 3.5, and its spectral type is given as B₃A in the Harvard classification. According to the elements now published, its period is 6.744 days, the velocity of the system is +23.3 km., and the length of the semi-major axis of the orbit is 1,960,000 km. For α Pavonis (mag. 2.0) the period is 11.753 days, the velocity of the system is +2.0 km., and the length of the semi-major axis is 1,170,000 km.; the orbit is nearly circular. The period of κ Velorum (mag. 2.6) is 116.65 days, the velocity of the system is +21.9 km., and the length of the semi-major axis = 73,200,000 km. All three stars are of the same type of spectrum.

MELLISSH'S COMET, 1907e.—A new set of elements and an ephemeris extending to December 31.5 are given in Lick Observatory Bulletin No. 124 for Mellish's comet. The position for December 11.5 is $\alpha = \text{oh. } 12\text{m.}$, $\delta = +27^{\circ} 2'$, about 13° south-east of α Andromedae, and the brightness is about one-third that at the time of discovery. The following positions are taken from the ephemeris:—December 23.5 (G.M.T.), $\alpha = 23\text{h. } 56\text{m.}$, $\delta = +26^{\circ} 30'$; December 31.5, $\alpha = 23\text{h. } 52\text{m.}$, $\delta = +26^{\circ} 30'$ (brightness = 0.09).

SOLAR PROMINENCES IN 1906.—Prof. Ricco's annual summary (1906) of the prominence observations made at Catania appears as an abstract from vol. xxxvi. (1907) of the *Memorie della Società degli Spettroscopisti Italiani*. The following are the mean values for the year:—daily frequency = 2.7, complete extension along the limb = $7^{\circ}.5$, height of prominences = $44^{\circ}.2$. As one would expect near the epoch of maximum, these values are nearly equal to those obtained in 1905. It is interesting to note that whereas the sun-spot frequency curve showed maxima in February and November, 1905, the prominence maximum appears to have been relatively retarded, the second greatest maximum recorded at Catania having occurred in March, 1906. Considering the heliographic latitude of the prominences in 10° zones, the principal maximum took place in $\pm 20^{\circ}$ to $\pm 30^{\circ}$, as in 1905, but the secondary maximum was elevated ten degrees from $\pm 60^{\circ}$ to $\pm 70^{\circ}$ to $\pm 76^{\circ}$ to $\pm 80^{\circ}$; this is another characteristic of the maximum epoch. Excepting the fourth trimestre, the number of prominences observed in the northern hemisphere of the sun was greater than that observed in the southern hemisphere, the numbers for the year being 284 and 185 respectively.

SEARCH EPHEMERIS FOR COMET 1907a (GIACOBINI).—Believing that comet 1907a might still be observed in large instruments or found on long-exposure photographs, Prof. Weiss publishes a search-ephemeris for this object in No. 4218 of the *Astronomische Nachrichten* (p. 300, December 2). The comet is now some 10 m. west of α Persei, and its estimated magnitude is 13.8.

PRIZES AWARDED BY THE PARIS ACADEMY OF SCIENCES.

Geometry.—The Francœur prize is awarded to Émile Lemoine, for the whole of his work in mathematics; the Bordin prize to F. Enriques and F. Severi jointly, the Vaillant prize being shared by J. Hadamard, Arthur Korn, Giuseppe Lauricella, and Tommaso Boggi.

Mechanics.—A Montyon prize is awarded to M. Cœnot, for his experimental studies on the flexure of rails; an exceptionally honourable mention to M. Petot, for his work on the theory of automobiles; the Poncelet prize to Colonel Renard, for his mathematical and experimental researches in mechanics, and for his contributions to aeronautics.

Navigation.—The extraordinary prize of six thousand francs is divided between M. Gayde (two-thirds) and J. Estève (one-third), the Plumey prize not being awarded.

Astronomy.—The Pierre Guzman prize is not awarded. T. Lewis receives the Lalande prize, M. Giacobini the Valz prize, and M. Gaillot the G. de Pontécoulant prize.

Geography.—The Gay prize is awarded to Jean Charcot, for his Antarctic explorations, the Tchihatchef prize being divided between Jacques de Morgan and Paul Crépin Bourdier de Beauregard.

Physics.—Lucien Poincaré receives the Hébert prize, for his book on modern physics; P. Langevin the Hugues prize, for his work on the mobility of gaseous ions and the properties of electrons; M. Mathias the Gaston Planté prize, for his work on terrestrial magnetism; Paul Villard the La Caze prize, for the whole of his researches in physics; and Pierre Weiss the Kastner-Boursault prize, for his experimental and theoretical work in magnetism.

Chemistry.—The Jecker prize is divided between MM. Blaise, Marcel Delépine, and Hamonet, and the Cahours prize between MM. Gain, Mailhe, and Guillemard. A Montyon prize (unhealthy trades) is awarded to M. Bonneville, for his discovery and manufacture of a cement in which metallic zinc replaces the red lead commonly used.

Mineralogy and Geology.—M. Martel is awarded the grand prize of the physical sciences, for his studies on underground waters, and J. J. H. Teall the Delesse prize, for his researches in petrography.

Botany.—The Desmazières prize is awarded to General E. G. Paris, for his "Index Bryologues"; the Montagne prize to F. Guéguen, for his work on the lower fungi; the De Coigny prize to F. Gagnepain, for his work on the classification of the Zingiberaceae; the Thore prize to M. Bainier, for his work on the lower fungi; and the de la Fons-Mélicocq prize to C. Houard, for his memoir on the parasitic deformations of plants in northern France.

Anatomy and Zoology.—Charles Alluaud receives the Savigny prize, for his work on the invertebrates of Upper Egypt and the adjacent portions of Africa.

Medicine and Surgery.—Montyon prizes are awarded to J. Henniquin, for his work on the treatment of fractures; C. Levaditi, for his researches on *Treponema pallidum*; and Maurice Villaret, for his researches in connection with urinary secretion. Mentions are accorded to A. Thiroux and M. d'Anfreville, for their memoir on malaria in Senegal; MM. Nicolle and Mesnil, for their memoir on the treatment of trypanosomiasis by the benzidine colours; and René Gaultier, for his memoir on the functional exploration of the intestine by analyses of the faeces. Gustave Martin, Georges Pécaud, Pierre Breteau and Paul Woog, A. Desmoulière, and M. Guisèz receive citations in connection with this prize. J. Guiart and L. Grimbart receive the Barbier prize for their book on chemical, microscopic, and pathological diagnosis. The Bréant prize (interest only) is divided between MM. Vaillard and Dopfer, for their researches on bacillary dysentery, and J. Ferran, for his work on the cholera bacillus. The Godard prize is given to Victor Nicaise, for his memoir on the indications and therapeutic value of total or partial nephrectomy in the treatment of hydratoid cyst of the kidney; the Baron Larrey prize to G. H. Lemoine, for his work on military hygiene; the Bellion prize to A. Chantemesse and F. Borel, for their memoir on the protection of the country from diseases introduced from abroad; the Mége prize to J. Castaigne and F. Rathery, for their work on the lesions of the convoluted tube of the kidney; and the Chausser prize to A. Lacassagne, for his work on forensic medicine.

Physiology.—The Montyon prize in experimental physiology is divided between Maurice Nicloux and Denis Broc-Rousseau, the former for his work on the physiological saponification of fatty substances, and the latter for his researches on the alterations of seeds, cereals, and forage. H. Bierry receives the Philippeaux prize, for his studies in cytochromes; Gaston Seillière the Pourat prize, for his memoir on the utilisation of the pentosans by the animal organism; M. Laulanié the La Caze prize, for the whole of his work in the field of general physiology, the Lallemand prize being divided between E. Régis and Étienne Rabaud.

Statistics.—A memoir on statistical methods and their applications, by Lucien March, is accorded the Montyon prize in statistics. J. A. Fleury receives a very honourable mention for his memoir on the statistics of the city of Rouen, and Dr. Conor an honourable mention for his memoir on hysteria in the army.

History of Science.—Prizes are awarded to Gino Loria and F. Brunet, F. de Mély being accorded a very honourable mention.

General Prizes.—Adolf von Baeyer receives the Lavoisier medal; MM. Blaise, Delphine and Hamonet, Berthelot medals; Charles Frémont, the Trémont prize; J. H. Fabre, the Gegner prize; Mmes. Beclard, Cosco and Ruck, the Lannelongue prize; Charles Nordmann and Jean Brunhes, the Wilde prize; MM. Gonessiat and de Seguier, the Saintour prize; Pierre Duhem, the Petit D'Ormy prize (mathematical sciences), J. Künckel d'Herculais, the Petit D'Ormy prize (natural sciences); A. Cotton, the Pierson-Perrin prize; Léon Daum, the prize founded by Mme. la Marquise de Laplace; and Léon Daum, Georges Jean Painvin, Charles Marie Joseph Cambournac, and Louis Eugène Galatoire Malgarie, the prize founded by Félix Rivot.

The Leconte prize is not awarded this year.

THE JOURNAL OF THE ROYAL ANTHROPOLOGICAL INSTITUTE.

THE new volume of the Journal of the Royal Anthropological Institute is dedicated, on the occasion of his seventy-fifth birthday, to Prof. E. B. Tylor, of whom a fine portrait forms the frontispiece. The dedication dwells on his classical contributions to the science of anthropology—his "Researches into the Early History of Mankind" and "Primitive Culture"—works which enjoy the almost unique distinction of never having been superseded by the studies of later writers; on his career as professor of anthropology at Oxford, where, as the result of his teaching and personal initiative, a diploma course in the science has been established; and on the generous encouragement bestowed by him on the students of a younger generation. This compliment to a scholar who stands in the foremost rank is graceful and well deserved.

The president, Prof. Gowland, in his annual address continues his studies of burial mounds in Japan which were begun by his well-known paper contributed to vol. lv. of "Archæologia." Here he deals with the remarkable structures which cover the remains of the early emperors. Some of these are of enormous extent; one when first erected must have been not less than 1000 feet long and 600 feet broad, while in spite of denudation its summit now rises to the height of 84 feet. It seems certain that several of these mounds are as early as the first or second century of our era, and their construction continued for some five or six centuries after that date. It ceased with the establishment of Buddhism, when the custom of inhumation was replaced by cremation. The examples of metal work found in these monuments—iron armour, swords, horse-trappings of iron covered with thin gilt copper foil—illustrate the national skill in metallurgy in those early times. Terra-cotta figurines mark the transition from the custom of burying attendants with the dead sovereign, a reform which the "Nihongi" Chronicle attributes to the Emperor Suinin, who reigned at the beginning of the Christian era. At many of these monuments the Japanese, ardent worshippers of ancestors, still perform annual rites, and the mounds are protected from desecration.

The most important contribution to physical anthropology, 1908. VOL. 77]

polo is the account, by Prof. Cunningham, of perhaps the most remarkable head of one of the Australian aborigines which has ever reached this country. It is that of a man who died in 1905 in a lunatic asylum, and it was most skillfully prepared by Dr. Ramsay Smith by means of injections of formalin. This head is distinguished by the great prominence of the supraorbital regions of the forehead, which is receding and sloping, by the width of the zygomatic region, and by the retreating chin and almost complete absence of a mental prominence. The type does not, as might have been expected from the reported cause of death—organic disease of the brain—seem to be abnormal.

Mr. H. Balfour contributes a good museum article on what he terms the friction drum, a curious musical instrument consisting of a drum with a single membrane, to the centre of which is attached a string, horsehair, or short stick, which on being rubbed with the moistened or rosined forefinger and thumb creates rapid vibrations communicated to the membrane. The instrument appears in Europe, North and South America, Africa, Japan, and India. It seems impossible to discover the original centre of dispersion; in fact, there appears no reason why it should not have been independently discovered in Africa or India, where it appears earlier than in other regions.

Archæology is represented by an account, by Canon Greenwell, of a remarkable find by Major Sykes of bronze weapons, implements, and vessels at Khinámán, in south-east Persia. "It is impossible," he writes, "to over-estimate the interest and value of this discovery. This arises not only from the nature of the articles themselves, but from the light it throws upon the early metallic stage of cultivation in that country, about which our information is very scanty." The axes are the most important and interesting. They could never have been used in war or for any other useful purpose, but were representative weapons made to be buried with the dead man in place of those which he used in life, or more probably were employed in processional rites, to be carried as a mark of dignity before a personage of rank. In the ornamentation, as in the case of two similar weapons previously discovered within the same Asian area, the lion appears as a prominent feature of the design.

EXPERIMENTS ON WIND-PRESSURE.

FURTHER experiments on wind-pressure were described by Dr. T. E. Stanton before the Institution of Civil Engineers on December 3. The first part of this research, of which the results were communicated to the same institution in December, 1903, was the investigation of the resultant pressure and distribution of pressure on flat plates normal to and inclined to the direction of a uniform current of air. The value of the constant K in the pressure velocity relation $P=KV^2$ was found to be 0.0027, a result somewhat smaller than those found by Dines, Frowde, and Langley. On the completion of this part of the work it was decided to make observations on flat surfaces of areas ranging up to 100 square feet when exposed to the wind, since general experience tended to show that in actual winds the velocity of which was not uniform over time or space, the mean pressure per square foot on a large surface was considerably less than that on a small one. For the purpose of the work a steel windmill tower was erected in the grounds of the National Physical Laboratory at Teddington. The experimental boards and models of structures were attached to a light framework carried by the cap of the tower, the height of the centre of the boards from the ground being 50 feet.

The results of observations on three pressure-boards, one 5 feet by 5 feet, one 5 feet by 10 feet, and one 10 feet by 10 feet, gave practically identical values of the constant in the pressure-velocity relation. In units of pounds per square foot and miles per hour, the mean value for this constant for the three boards was 0.0032. Further observations on the intensity of the pressure at the front and back of the boards appeared to show that the cause of the higher value of the constant compared with that obtained in the case of the small plates of the earlier experiments was the relatively greater intensity of the negative pressure at the

back of the boards compared to that at the back of the small plates. Experiments were also made on a model of a braced girder 29 feet long by 3 feet 7 inches deep, and on a roof model the sides of which were 8 feet by 7 feet. The ratio of the resistance per unit of area of the model girder to that of a square board in the wind was found to be precisely the same as the ratio of the resistance per unit of area of a small model of the girder made to a linear scale of 1 in 42 to a square plate in the experimental channel and uniform current used in the previous experiments. The resultant pressures on the roof were obtained, for both windward and leeward sides, at angles of 30, 45, and 60 degrees inclination to the horizontal, and indicated the considerable suction effects on the leeward side of a roof when the pressure inside the building is augmented from the windward side by open doors or windows. The results lead to the conclusion that the resistance of a complicated structure in the wind can be accurately predicted from a determination of the resistance of a small model of the structure in an experimental channel.

UNIVERSITY AND EDUCATIONAL INTELLIGENCE.

CAMBRIDGE.—Sir James Dewar has nominated Mr. H. O. Jones, of Clare College, as deputy for the Jacksonian Professor of mental philosophy during the Lent term 1908. This nomination has received the consent of the Vice-Chancellor and the Sex Viti.

The sites syndicate recommends that a site on the Downing ground 40 feet wide, situate to the south of the botanical laboratory and parallel to it, be assigned for a building in connection with the Department of Agriculture.

Mr. W. Bateson, F.R.S., has been appointed reader in zoology.

Dr. Baker has been appointed chairman of the examiners for the mathematical tripos, part ii., 1908.

Prof. Nuttall has appointed F. P. Jepson, Pembroke College, to the studentship in medical entomology in place of A. H. Lees, who has resigned the studentship.

The board of agricultural studies is of opinion that the subjects which come under its cognisance are now too wide and too complex to be entrusted to a single professor. The appointment of Mr. T. B. Wood, of Gonville and Caius College, to the Drapers' professorship of agriculture has adequately provided for the teaching of agricultural chemistry, but the board is of opinion that it is urgently necessary that a professor in agricultural botany should be appointed without delay. This proposal has been brought within the range of possibility by the munificence of the Drapers' Company, which has offered a further grant of 200*l.* a year towards the stipend of a professor of agricultural botany. The general board has now put forward a report in which it recommends the establishment of such a professorship. This report will be discussed at an early date next term. The teaching of practical agriculture is entrusted to Mr. K. J. J. Mackenzie, late of the South-Eastern Agricultural College, Wye.

LONDON.—The committee of University College will shortly proceed to appoint a Derby scholar in zoology. The value of the scholarship is 60*l.* per annum, the scholarship being tenable for two years. An examination for the award of the scholarship will be held at University College on December 18. Full particulars can be obtained on application to the secretary, University College, Gower Street, W.C.

MANCHESTER.—The University will eventually benefit under the will of the late Prof. Thomas Barker, who from 1865-1885 was professor of mathematics at Owens College. The legacy, which it is estimated will amount to about 36,000*l.*, is to found a professorship of cryptogamic botany, and to establish scholarships for the assistance of students, especially those of slender means, in the departments of botany and mathematics.

OXFORD.—A portrait of Dr. A. J. Evans, F.R.S., the keeper of the Ashmolean Museum, painted by Sir William B. Richmond, was presented to the University on Saturday, December 7, in the presence of a large and dis-

tinguished company. The presentation was made on behalf of the subscribers by the principal of Brasenose, and the Vice-Chancellor accepted the portrait for the University.

MR. HALDANE, M.P., will, on Saturday, December 14, unveil the statue of the King, to be placed over the central entrance of the new buildings of University College School, Hampstead.

THE Melbourne correspondent of the *Daily Chronicle* reports that Mr. T. W. Stanford, brother of the founder of Stanford University, San Francisco, intends to leave by his will 50,000*l.* to found eight annual scholarships at Stanford University for young Australians. All candidates must pledge themselves to return to Australia and use the knowledge gained at the University in developing their native country.

SPEAKING at the Derby Municipal Technical College on December 5, Mr. Victor Cavendish, M.P., said he wished they could send forth from that gathering a message to those engaged in educational controversies that would result in placing education out of the range of controversy. He believed that money spent in extending the operations of institutions of that character was money well spent, and money from which, at no distant date, a most adequate and healthy return would be seen. Another subject was as to what extent we could improve our industrial and commercial position in the world. Upon such a question as foreign competition he felt that, however much they might differ on certain points, at any rate on the question of education they could unite in doing something for the future of the country by seeing that the youth of the nation had the very best technical education that could be given. Any money spent on such objects ought to receive the greatest support and consideration from all parties.

DURING the course of last week the Society of Merchant Venturers concluded the final arrangements for the reconstruction of the main building of their technical college in Bristol, and the work will now proceed with all possible speed. The society has devoted a large sum for additions to and improvements in the equipment of the departments of engineering, chemistry, and applied physics. In order to benefit by the most recent experience gained elsewhere, the principal and other members of the staff have visited some of the best-equipped technical and university colleges in Germany and in the United Kingdom.

To encourage the teaching of facts regarding weather and climate in schools, the council of the Royal Meteorological Society invites elementary teachers and others to send in essays in the form of an original nature-study lesson on weather or climate (not exceeding 1500 words in length), together with a brief synopsis of five other lessons to cover the whole subject of climate and weather. If essays of sufficient merit are received, three prizes will be awarded of 5*l.*, 3*l.*, and 2*l.* respectively. The essays are to be sent in before January 31, 1908, and addressed to Mr. William Marriott, assistant secretary, Royal Meteorological Society, 70 Victoria Street, London, S.W., from whom further information can be obtained.

The fifth annual prize distribution of the Sir John Cass Technical Institute was held on Tuesday, December 3, when the prizes were distributed and an address given by Dr. R. T. Glazebrook, F.R.S. The chair was taken by Sir Owen Roberts, chairman of Sir John Cass's foundation. Dr. Glazebrook, in reviewing the work of the institute, dwelt upon the importance of the average amount of work done by each student rather than the number of students in attendance as a criterion of the value of the instruction given, and also pointed out the desirability of encouraging students in every possible way to follow grouped courses of study of a continuous character if real advantage is to follow from their labours. Further, it is necessary always to remember that learning and the assimilation of knowledge, admirable though they are in themselves, are not all there is to strive for, but that research or discovery of new laws or of more complete order rests on a higher plane. Dr. Glazebrook then contrasted the lot of the students of the institute with that of men in similar positions a hundred years ago, pointing

out in a review of the early life and struggles of Faraday how difficult it was then to obtain the least help in study compared with the accessible advantages that are so widely distributed over the country to-day. The students accordingly should fully appreciate their opportunities and use them to the best advantage, not merely as a means for the acquisition of knowledge, valuable and important as this is, and, above all, not as something which may lead to material advancement, but as a means of training the powers possessed by each so as to develop them for action beneficial both to themselves and to their fellows. A hundred years ago men like Faraday, Watt, and Arkwright worked at a time when the world was comparatively young in knowledge; they had a clean slate to write upon. But while the difficulties of their pioneer work were enormous, and they started from a position of comparative ignorance of scientific principles, and simple in character as their respective discoveries were, the applications which have followed from them have led to a high general level of scientific knowledge to-day which has become the starting point for modern conditions of study. Accordingly, if the country is to profit by the modern progress of science, the mass of the people must be educated up to this higher plane of knowledge, for it is by intelligent action and patient effort and devotion on the part of the rank and file of workers that general advances come. The work of the Sir John Cass Institute and of similar schools throughout London is exerting a most important influence in securing this higher level of knowledge for those engaged in work associated with the industries of the country.

SOCIETIES AND ACADEMIES.

LONDON.

Royal Society, June 20.—"On the presence of Sulphur in some of the Hotter Stars." By Sir Norman Lockyer, K.C.B., F.R.S.

In this paper the author gives an account of the discovery of the strongest spark lines of sulphur in the spectrum of Rigel. These lines had not previously been traced in any celestial spectrum. It is also shown that two strong sulphur lines (4253.8, 4285.1), which are of abnormal behaviour in the spark and vacuum-tube spectra, are lacking in the Rigel spectrum; they have been found to occur, however, in the Crucian (Bellatrix) and Alnitamian (ϵ Orionis) types of stellar spectra, which represent higher stages of temperature than the Rigelian type. In the two types mentioned the Rigel-sulphur lines are either lacking or very weak.

Concisely, the following represents the relative and inverse behaviour of the two sets of lines in stellar spectra:—

Group	Type Star	Sharp Lines (4253.8, 4285.1)	Diffuse lines
Alnitamian	ϵ Orionis	Well shown	Absent
Crucian	γ Orionis	Present, but weaker than in ϵ Orionis	Strongest lines present, but weaker than in β Orionis
Rigelian	β Orionis	Absent	Well shown

November 7.—"Note on the Association of Helium and Thorium in Minerals." By the Hon. R. J. Strutt, F.R.S.

The question has been often raised of whether or not helium is a product of thorium radio-activity. The author's view throughout has been that it is (Roy. Soc. Proc., vol. lxxiii., p. 191, 1904, also March 2, 1905). Mr. Boltwood has recently argued that the helium in radio-active minerals may always be attributed to the action of the uranium-radium series of transformations (*Am. Journ. Sci.*, vol. xxxiii., February, p. 77). In the present note the author directs attention to a case where that view is clearly untenable.

Prof. Julius Thomsen, of Copenhagen, described, in 1898 (*Zeit. physikalische Chemie*, vol. xxv., part iii.), a helium mineral from Ivtigut, Greenland, similar in some respects to fluor-spar, but containing rare earths. Recently he has determined the quantity of helium liberated on

heating as 27 c.c. per kilogram (*Bull. de l'Acad. Royale des Sciences*, Copenhagen, 1904, 53-57).

Prof. Thomsen kindly sent a supply of this mineral to the author, who has carefully tested it for radium, and finds that it contains no more than the traces which are ubiquitous in rocks and minerals. The quantity found was, in fact, about the same as in average rocks, and is insufficient to account for one-hundredth part of the helium present.

On the other hand, a solution of the mineral gave abundant thorium emanation. The author is inclined to think that there is some unknown complication about the thorium-emanating power of solutions which makes it unsafe, in certain cases at least, to infer from it the quantity of thorium present; but enough thorium emanation was given off by the solution to show that thorium was a substantial constituent of the mineral. He regards it as entirely certain that the helium in this mineral has not been generated *in situ* by uranium or radium, and has no hesitation in connecting it with the presence of thorium.

"On the Measurement of Temperatures in the Cylinder of a Gas Engine." by Prof. Callendar, F.R.S., and Prof. W. E. Dalby.

It is important in the experimental investigation of the internal-combustion engine to be able to measure the temperature at a suitable point in the cycle.

The difficulty of making this direct measurement arises from the fact that during the cycle of operations in the working cylinder the temperature rises above the melting point of platinum or of any thermoelectric couple which can be used for the observation. Also, since the temperature is changing so rapidly, whatever apparatus is used to measure the temperature must have small mass; moreover, its insertion in the cylinder of the engine must not alter the volume or disposition of the clearance space, otherwise there will be danger of pre-ignition.

The authors use a platinum wire 0.01 inch diameter and 1 inch long in conjunction with a compensator of the same diameter and $\frac{3}{8}$ -inch long, and the temperature is measured by measuring the change of resistance corresponding to the middle $\frac{3}{8}$ -inch of the 1-inch wire. To avoid the difficulty experienced by previous experimenters in this direction, the platinum thermometer is screened from the high temperature by placing it in a valve which allows the thermometer to be exposed during any part of the cycle for a suitable interval of time, and to be perfectly protected from the high temperature when the valve is closed. This valve is contrived in the spindle of the admission valve, and the gear for operating it is clearly shown in the figures in the paper. The advantage of this position is that as the whole charge of air and gas streams into the cylinder around the spindle of the admission valve the temperature of the valve and the thermometer inserted in it are brought continually into approximation during the whole of the suction stroke, so that at the instant when the contact is made for the measurement of the temperature, namely, just after the close of the admission valve, the thermometer and the temperature it is required to measure do not differ widely in temperature; moreover, at this point in the cycle the rate of change of the temperature is nearly a minimum. In measurements of this kind it is essential that there should be no missed explosions, and the authors therefore arranged the engine so that this condition should be exactly fulfilled during the whole of the experiments.

Experiments were made to determine the lag of the platinum thermometer behind the temperature of the fluid it purported to measure, and to determine the effect of the valve carrying the thermometer on the temperature indicated by the thermometer. The conclusion arrived at by the authors is that the method may be used to give the temperature of the charge at the beginning of compression within 1° C.

A few experiments were quoted in the paper, from which it appears that at full load the temperature rises to a point between 2000° C. and 2500° C. when the mixture is rich.

Geological Society, November 6.—Sir Archibald Geikie, K.C.B., Sec.R.S., president, in the chair.—A collection of fossil plants from South Africa; Prof. A. C. Seward. The material on which this paper is based was, for the

most part, collected by members of the Geological Survey in Cape Colony from the Molteno and Burgersdorp beds. The Molteno beds are placed at the base of the Upper Karroo, or Stormberg series; the Burgersdorp beds constitute the uppermost strata of the Middle Karroo, or Beaufort series. Mr. A. L. Du Toit, who has contributed accounts of the stratigraphy of the plant-bearing and associated rocks, describes the occurrence of a transitional zone between the Molteno and the Burgersdorp beds. A description is also given of *Schizoneura africana*, Feistmantel, a species originally figured by Hooker in an appendix to Bain's paper, published in 1845. The additional plants recorded from the Molteno beds afford further evidence in favour of assigning this member of the Stormberg series to the Rhaetic period. While possessing certain Rhaetic species, the Burgersdorp flora as a whole indicates a somewhat lower horizon.—Permo-Carboniferous plants from Vereeniging (South Africa): Prof. A. C. Seward and T. N. Leslie. The majority of the specimens described in this paper were obtained by Mr. Leslie from a sandstone quarry $1\frac{1}{2}$ miles from Vereeniging, on the banks of the Klip River; the sandstones are associated with shales, coal-seams, and glacial conglomerates. In the opinion of the authors, the plant beds should be included in the Ecra series (Lower Karroo). While recognising certain well-marked differences between the Glossopteris flora and the Upper Carboniferous and Permian floras of the northern hemisphere, they are inclined to think that there are more types common to the two botanical provinces than is generally supposed.—The structure and relations of the Laurentian system of Canada: Prof. F. D. Adams. This paper contains an outline of the results of the examination by Dr. Barlow and the author of an area of 4200 square miles, comprised within the Haliburton and Bancroft sheets of the Ontario and Quebec series of maps. The main conclusions reached by the author may be thus summarised:—(1) The Laurentian system of Sir William Logan consists of a very ancient series of sedimentary strata, largely limestones, invaded by great volumes of granite in the form of batholiths. (2) This sedimentary series is one of the most important developments of the pre-Cambrian rocks in North America, it presents the greatest body of pre-Cambrian limestones on the continent, and it is best designated as the Grenville series. (3) The invading masses of granite are of enormous extent; they possess a more or less distinct gneissose structure, due to the movements of the magma, which developed a fluidal and, in the later stages of intrusion, a proclastic structure in the rock. (4) The granite gneiss of the batholiths not only arched up the invaded strata into a series of domes, but "stopped" out portions of the sides and lower surface of the arches, the fragments torn off from walls and roof by the invading granite being found scattered throughout the mass of the invading rock; this "stopping," however, probably developed only a small part of the space which the granite now occupies. (5) The invading granite not only exerted a mechanical action upon the invaded strata, but also gave rise to a variety of metamorphic products, among others amphibolite, produced by its action in the limestone, which accounts for the fact that while the invaded strata are chiefly limestone, the fragments of the latter, where found in the granite, consist of amphibolite. (6) The invading batholiths and allied intrusions of granite occupy the greater part of the great northern protaxis of Canada, which has an area of approximately 2,000,000 square miles. It has, therefore, been considered advisable to restrict the name Laurentian to this great development of the "fundamental gneiss," which, although intrusive into the Grenville series, nevertheless underlies and supports it. (7) The relation of the Grenville series, which forms the base of the sedimentary portion of the geological column in eastern Canada, to the Huronian and Keewatin series, which are the oldest stratified rocks in the western part of the protaxis, has yet to be determined, the two not having so far been found in contact; nowhere, moreover, either east or west, has the original basement on which the first sediments were laid down been discovered; these are everywhere torn to pieces by the granite intrusions of the Laurentian.

Linnean Society, November 7.—Prof. W. A. Herdman, F.R.S., president, in the chair.—The origin of the ditrimorous floral whorls of certain dicotyledons: Rev. G. Henslow. The object of the present paper was to show that the ternary arrangements of monocotyledons are not derived from the same source as those of certain dicotyledons, every verticil of three members in the former being a single cycle of the $\frac{1}{3}$ divergence, while in the latter the usually double verticils are derived from the $\frac{2}{3}$. This divergence is unknown in the foliage of monocotyledons, $\frac{1}{2}$ or $\frac{3}{4}$ being the natural sequence from a single cotyledon, whereas $\frac{2}{3}$ necessarily follows on the two cotyledons or from opposite and decussate leaves.—Eight very remarkable new species of Acari from New Zealand, from the collection of the late E. Bostock, six Oribatida and two Gamasida: A. D. Michael. The species are to be called *Oribata bostockii*, distinguished by the pteromorphæ being attached to the anterior margin of the abdomen instead of its lateral margin; *Notaspis spinulosa*, carrying spinulated hairs of extraordinary size; *Notaspis caudata*, with a posterior projection not hitherto found in the genus; *Hermannia phyllophora*, with great leaf-like processes on the legs; *Nothrus cophinarius* and *N. unguifera*, extreme exaggerations of that section of the genus represented in Europe by *N. spiniger*; *Trachynotus sclerophyllus*, in which the great leaf-like transparent hairs found on many Acari have become opaque, hard, brown chitin; and *T. fimbriatus*, with singular flattened borders to the first pair of legs, much broader than the legs themselves.—*Enigmatistes africanus*, a new genus and species of Diptera: R. Eshford.

November 21.—Prof. W. A. Herdman, F.R.S., president, in the chair.—*Exhibits*.—C. W. Anderson: A specimen of a light-giving larva brought by him from near the boundary of British Guiana with Brazil, exhibiting when living a ruby light in its head, and a double row of phosphorescent spots along the body, two on each segment. These lights were not intermittent, but glowed continuously. This presumed coleopterous larva was called "Macadoub" by the natives, and is not uncommon in the region named.—Prof. Dendy: Two living specimens of *Peripatus* from the Cape, which he had succeeded in keeping in excellent health by supplying them with woodlice as food.—*Papers*.—Abnormal structures in leaves and their value in morphology: W. C. Worsdell. *Dichotomy*, as in crested fern leaves, is a reversion to a primitive type of frond-branching. In cotyledons it represents a tendency, which in this case is progressive and not reversionary, to increase the number of cotyledons. *Phyllotaxis*: Dichotomy of foliage leaves is, in the author's opinion, a reversion from the opposite, or distichous, arrangement to form a greater number of leaves on the axis; it is probably a step towards the original spiral arrangement. *Spiral torsion* is due to a reversion from the opposite or whorled arrangement of leaves to the spiral arrangement. *Terminal leaves*: This is regarded as a reversion to the primeval structure in which, according to the phyton theory, each leaf terminates each segment of the stem above which it is situated, every leaf being thus essentially a terminal organ and not lateral. *Evolution and ascidia*: The foliage leaves of *Saxifraga ligulata* show formation of basal pockets on upper side of leaf and transformation of entire leaf into a cup-shaped structure; also infolding of basal lobes, which infolding may extend right up midrib to apex. This infolding may also occur for a short distance from the apex downwards. A similar structure may be represented merely by slight enations on either side of the midrib. Lobing may occur at the apex; small lobes may become abstricted off as stalked structures, which may either be terminal or carried over on to the dorsal (lower surface) of the leaf in form of small, stalked ascidia. *Tirescence*: The various foliar organs of the flower may revert to the condition of foliage leaves, e.g. phyllody of the calyx in the rose, phyllody of carpels in Trifolium. *Monocotyledonous seedlings in dicotyledons*: Normal cases of this occur, as in *Ranunculus Ficaria*, L.; here the conditions are regarded as primitive. Abnormal cases occur in which the two cotyledons arise congenitally fused into a single one, as in Umbelliferae. This is a reversion to the primitive condition.—Two new species of

Amphipoda: Rev. T. R. R. Stebbing. The species were described as *Lepchinella chrysothorax*, representing a new genus in the family Paramphithoidea, and *Rhachotrochis palporum* in the family Eusiridae.—The preservation of specimens in Australian museums: J. G. Otto Topper. The author pointed out that the life-cycle of *Anthrenus muscaeorum* involved visits to flowers, and that the presence of their destructive larvae in museum collections was due to the eggs being laid in proximity to the cases, and the active and minute larvae subsequently finding their way into the containing cases by cracks or similar apertures.

Mineralogical Society, Nov. 12.—Prof. H. A. Miers, F.R.S., president, in the chair.—Hopeite and other zinc phosphates and associated minerals from Broken Hill mines, north-western Rhodesia: L. J. Spencer (see NATURE, vol. lxxvi., p. 215). Hopeite is abundant as brilliant water-clear crystals or as larger white crystals reaching 2 cm. across. The crystals are orthorhombic, with $a:b:c=0.5786:1:0.4758$. Cleavage flakes parallel to the brachypinacoid show a zonal intergrowth of two substances, distinguished as α -hopeite and β -hopeite; these differ considerably in their optical characters, and slightly in sp. gr. (3.0-3.1) and the temperature at which water is expelled. Associated with the hopeite crystals on the bone-breccia are brown botryoidal masses of vanadinite. The other zinc phosphates occur, not in the bone cave, but with cellular limonite and crystals of desclorite and pyromorphite in connection with the zinc-lead ores (which consist of an intimate mixture of cerussite and hemimorphite with interspersed limonite). The new species, *tarbutite*, occurs in great abundance, and is a basic zinc phosphate, $Zn_3P_2O_8 \cdot Zn(OH)_2$, with sp. gr. 4.15; the crystals are anorthic with $ac=55^\circ 50'$, $ab=84^\circ 34'$, $bc=76^\circ 31'$, c being a direction of perfect cleavage. Pseudomorphs of *tarbutite* after *calamine* ($ZnCO_3$), desclorite, and hemimorphite are not uncommon. Another new species, named *parahopeite*, has the same chemical composition as hopeite, $Zn_3P_2O_8 \cdot 4H_2O$, but is anorthic, with sp. gr. 3.31. The platy crystals somewhat resemble hemimorphite in appearance; they have one perfect cleavage, approximately perpendicular to the plates, through which emerges one of the optic axes.—The question of a relation between isomorphous miscibility and parallel growths: T. V. Barker. A study of the growths on each other of immiscible or slightly miscible pairs of substances has shown that, although miscibility and parallel growths are favoured by the same factor—similarity of molecular volume—yet the two properties do not always go hand in hand, for many immiscible or only slightly miscible substances form parallel growths quite readily. Mixed crystals, therefore, should not be regarded as built up of alternating parallel layers.—Notes on zeolites from Cornwall and Devon: A. Russell. The occurrence of zeolites in various localities was described, e.g. that of heulandite near Okehampton, stilbite at Botallack and St. Ives, chabazite at Luxullian, apophyllite and analcite at Lostwithiel.—Note on the crystallisation of potassium bichromate: Prof. H. A. Miers. Two stages of growth of potassium bichromate crystallising from a drop of solution were described and illustrated by lantern-slides.—Various minerals from the Lengenbach quarry and the Ofenhorn, Binnenthal: R. H. Solly. Crystals of binnite, one of them a unique twin, and examples of the regular intergrowth of sartorite and baumhauerite, were described, and the occurrence of brookite and molybdenite on the Ofenhorn was for the first time recorded.—Mr. L. J. Spencer exhibited on behalf of Dr. H. J. Johnston-Lavis some minute crystals of hematite found in association with chloromanokanokite in blocks ejected from Vesuvius during the eruption of 1906. The crystals have the form of acute scalenohedra $\beta[31\bar{3}] = \{2461\}$.—A fine series of zeolites from the neighbourhood of Belfast was shown by Mr. F. N. A. Fleischmann; a new meteoric stone from Simondium, Cape Colony, by Dr. G. T. Prior; specimens of reconstructed ruby and blue spinel, and of the new gem, benitoite, by Dr. G. F. Herbert Smith; and a specimen of artificial hematite by Mr. C. J. Woodward.

Royal Anthropological Institute, November 19.—Mr. F. W. Rudler, past-president, in the chair.—Excavation of a barrow at Chapel Carn Brea, Cornwall: H. C. King and B. C. Polkinghorne. The barrow was opened in August, and was found to contain a cist built of flat-faced irregular stones with capstone. A very fine large urn, ornamented with the characteristic pattern, was found, containing partly calcined bones. Flint flakes were found, but these were of earlier date than the urn, and were probably placed in the cist from traditional motives. The barrow may have been surrounded by standing stones, as one is still in position. Above the cist at the north end another somewhat smaller urn was discovered.—Holed stone at Kerrow, St. Just in Penwith, Cornwall: H. C. King and B. C. Polkinghorne. This consists of a circular slab of granite with a cylindrical hole in the centre, very well worked, apparently by iron tools. Wood charcoal was discovered underneath. Its purpose is unknown.—Small cist and urn at Tregiffan Veau, St. Just in Penwith: H. C. King and B. C. Polkinghorne. The cist is a small one with a broken capstone. The urn, which is also small, dates about 400 B.C. No bones or ashes were found.—The Wild tribes of the Ulu Plus, Malaya Peninsula: F. W. Knocker. The tribes dealt with occupy the upper waters of the Plus River in Perak. They are apparently of mixed Semang-Sakai characteristics. The paper dealt with their habits of life, manners, and customs.

Chemical Society, November 21.—Sir William Ramsay, K.C.B., F.R.S., president, in the chair.—Emulsions: S. Pickering. Paraffin oil, when churned with solutions of soap, glue, starch, albumen, &c., forms an emulsion, which rises, like cream, to the surface of the excess of water, and contains from 65 per cent. to 82 per cent. by volume of oil. The percentage of oil can be increased to 99 per cent., the emulsion then being practically solid. Emulsification seems to depend on the separation from the liquid of very minute solid particles, which are attracted by and surround the oil globules, thus preventing them from coalescing. Any precipitated substance which is sufficiently finely divided will act as an emulsifying agent, but, after becoming agglomerated by drying, it loses this property.—Aromatic azoimides, part iii., the naphthylazoimides and their nitro-derivatives: M. O. Forster and H. E. Fierz.—The triazo-group, part i., triazoacetic acid and triazoacetone (acetylazoimide): M. O. Forster and H. E. Fierz. The interesting properties displayed by the triazo-

group when occurring in the complex $\begin{matrix} | \\ -CH.N_3 \\ | \\ -CO \end{matrix}$ have led

the authors to prepare the simplest typical compounds of this class, triazoacetic acid and triazoacetone.—Studies of dynamic isomerism, part vii., note on the action of carbonyl chloride as an agent for arresting isomeric change: T. M. Lowry and E. H. Magson. Labile solutions of nitrocamphor, in which isomeric change has been suspended, have been prepared (1) accidentally by dissolving nitrocamphor in chloroform, and (2) deliberately by adding acid to the solvent chloroform. In the latter case the solutions acquired a powerful odour of carbonyl chloride, and there can be no doubt that this is the efficient agent in arresting isomeric change in chloroform solutions. By means of this new agent it is possible to arrest the isomeric change of nitrocamphor in other solvents.—The electrometric determination of the hydrolysis of salts: H. G. Denham.—The interaction of metallic sulphates and caustic alkalis: S. Pickering. Alkalis, added to solutions of various metallic sulphates, precipitate a definite basic sulphate, except in the case of manganese and magnesium, where the hydroxide is precipitated. The further addition of alkali converts the basic sulphate either into another, sometimes consecutively into two other, more basic products (for example, copper and nickel), or into the hydroxide.—The chemistry of Bordeaux mixture: S. Pickering. The substances formed on the addition of lime to copper sulphate, as in the preparation of Bordeaux mixture, are dependent on the proportions of lime used, and may be either

- (1) $4\text{CuO}\cdot\text{SO}_3\cdot 0\cdot 06\text{CaSO}_4$;
- (2) $5\text{CuO}\cdot\text{SO}_3\cdot 0\cdot 25\text{CaSO}_4$;
- (3) $10\text{CuO}\cdot\text{SO}_3\cdot 1\cdot 3\text{CaSO}_4$;
- (4) $10\text{CuO}\cdot\text{SO}_3\cdot 4\text{CaO}\cdot\text{SO}_3$;
- (Possibly 5) $10\text{CuO}\cdot\text{SO}_3\cdot 10\text{CaO}\cdot\text{SO}_3$; or
- (6) $\text{CuO}\cdot 3\text{CaO}$;

that present in most cases probably being (4). The fungicidal action of Bordeaux mixture seems to depend on the liberation of copper sulphate by the action of carbon dioxide on the basic sulphate.—The alcohols of the hydroaromatic and terpene series, part i., resolution of the alcohols into their optically active components and the preparation of the borneols: R. H. Pickard and W. O. Littlebury. The alcohol is combined with phthalic or succinic anhydride, and the resulting acid ester resolved by *l*-menthylamine or other strong optically active base.—The electrolytic preparation of disulphides, part i., dibenzylsulphide and diethylsulphide: T. S. Price and D. F. Twiss.—The influence of solvents on the rotation of optically active compounds, part xi., ethyl tartrate in aliphatic halogen derivatives: T. S. Patterson and D. Thomson.—The interaction in solution of ferrous sulphate and copper sulphate: H. R. Ellis and W. H. Collier. No action takes place between ferrous sulphate and copper sulphate solutions in the cold, but on boiling, the copper sulphate slowly oxidises the ferrous hydroxide produced by hydrolysis. An account is also given of the action of ammonia solution on mixtures of ferrous and cupric sulphates in water.—Mercurous hyponitrite: E. Divers.—Decomposition of mercurous and silver hyponitrites by heat: E. Divers.—Cupric nitrite: E. Divers.

DIARY OF SOCIETIES.

THURSDAY, DECEMBER 12.

ROYAL SOCIETY, at 4.30.—Further Consideration of the Stability of the Pear-Shaped Figure of Equilibrium of a Liquid Earth: Sir G. H. Darwin, K.C.B., F.R.S.—Preliminary Note on the Operational Variants of a Binary Quantic: Major P. MacMahon, F.R.S.—The Action of Ozone on Water-Carrier Comets: Sir W. Abney, K.C.B., F.R.S.—On Kinetic Stability: Prof. H. Lamb, F.R.S.—The Absorption Spectra of the Vapours of Benzene and its Homologues at Different Temperatures and Pressures, and likewise of Solutions of Benzene: Prof. W. N. Hartley, F.R.S.—The Spectrum of Magnesium and of the so-called Yellow Line: Prof. S. T. Shovelton.—Reduced Pressure: E. E. Brooks.—Magnetic Declination at Kew Observatory, 1890 to 1900: Dr. C. Chree, F.R.S.—The Effects of Temperature and Pressure on the Thermal Conductivities of Solids. Part ii., The Effect of Low Temperatures on the Thermal Conductivities of Pure Metals and Alloys: Prof. C. H. Lees, F.R.S.—On Exterior Ballistics, No. 2: Prof. G. Forbes, F.R.S.

SOCIETY OF ARTS, at 4.30.—Big Game in India: R. Gilbert. MATHEMATICAL SOCIETY, at 6.30.—A Formula in Finite Differences and its Application to Mechanical Quadrature: Mr. S. T. Shovelton.—Water-stress: Excess-function in the Calculus of Variations: Prof. A. E. H. Love.

FRIDAY, DECEMBER 13.

MALACOLOGICAL SOCIETY, at 8.—Additions to the Marine Molluscan Fauna of New Zealand, with Descriptions of New Species: H. Suter.—Alteration to the name of *Alitra recurva*, Sow. (preoccupied): G. B. Sowerby.—Descriptions of New Species of Fresh-water Shells from Central Africa: C. A. Smith.—New Land and Marine Shells from West Africa: H. H. Perceval.

SOCIETY OF ARTS, at 8.—Industrial Poisons—Lead and Phosphorus—with Special Reference to the Manufacture of Lucifer Matches: Prof. T. Oliver.

PHYSICAL SOCIETY, at 7.30.—Exhibition of Electrical, Optical, and other Physical Apparatus.

ROYAL ASTRONOMICAL SOCIETY, at 5.—Observations of the Transit of Mercury, November 14, 1907: E. T. Whitelov.—Solar Parallax Papers, No. 6, Construction of a Standard Catalogue of Photographic Star-places: A. R. Hinks.—Observation du Passage de Mercure sur le Soleil, le 14 Novembre, 1907: R. Jonckheere.—Observations of Saturn's Ring at the Time of its Disappearance in 1907, made with the 40-inch Reflector of the Yerkes Observatory: E. E. Barnard.—On the Lunar Inequalities due to Planetary Action: Ernest W. Brown.—The Transit of Mercury, 1907 November 14: R. E. A. Innes.—Occultations of Uranus by the Moon in 1908, Visible at British Observatories: A. M. W. Downing.—On Ancient Eclipses: P. H. Cowell.—On the Mean Distances of the Groombridge Stars: A. S. Eddington.—*Probable Paper*: Note on the Single Equations which comprise the Theory of the Fundamental Astronomical Constants: Sir R. S. Ball.

SATURDAY, DECEMBER 14.

ESSEX FIELD CLUB (at Essex Museum of Natural History, Stratford), at 6.—Discussion on Rivers Pollution from the Naturalists' Point of View: Opened by Prof. R. Meldola, F.R.S.

MONDAY, DECEMBER 16.

ROYAL GEOGRAPHICAL SOCIETY, at 8.30.—In Search of an Arctic Continent: A. H. Harrison.

SOCIETY OF ARTS, at 8.—The Theory of the Microscope: Conrad Beck. SOCIOLOGICAL SOCIETY, at 8.—The Tutelage of Races: J. M. Robertson, M.P.

INSTITUTE OF ACTUARIES, at 5.—On the Method of Dr. Johannes Karpup of Valuing in Groups Endowment Assurances, and Policies for the Whole of Life by Premiums Limited in Number: G. King.—Bonus Reserve Valuations: C. K. V. Couatts.

TUESDAY, DECEMBER 17.

SOCIETY OF ARTS, at 8.—How to Make the Most of a Museum: Lewis F. Day.

ROYAL ANTHROPOLOGICAL INSTITUTE, at 8.15.—A Japanese Book of Divination: W. G. Aston, C.M.G.

ROYAL STATISTICAL SOCIETY, at 5.

INSTITUTION OF CIVIL ENGINEERS, at 8.—Keyham Dockyard Extension: Sir Whately Eliot.—Keyham Dockyard Extension: Temporary Works, and Plant and Appliances used in Construction: G. H. Scott.

FARADAY SOCIETY, at 8.—A Physico-chemical Study of the Complex Copper-Glycolic Sulphates: T. Barker.—The Centenary of the Discovery of the Alkali Metals by Davy; the Industrial Developments of the Discovery: Dr. F. Mollwo Perkin.

WEDNESDAY, DECEMBER 18.

ROYAL METEOROLOGICAL SOCIETY, at 7.30.—The Possibility of a Topography of the Air based on Balloon Observations with Special Theories: Captain C. H. Ley.—Indications of Approaching Frost: R. Strachan.

GEOLOGICAL SOCIETY, at 8.—Some Recent Discoveries of Palaeolithic Implements: Sir John Evans, K.C.B., F.R.S.—On a Deep Channel of Drift at Hitchin (Hertfordshire): W. Hill.

BRITISH ASTRONOMICAL ASSOCIATION, at 5.

ROYAL MICROSCOPICAL SOCIETY, at 8.—Some African Rotifers: Jas. Murray.—Gregory and Wright's Microscope; and a Correction for a Spectroscope: E. M. Nelson.—Exhibition of Selinite Specimens showing Interesting Features due to Twinning: E. Large.

THURSDAY, DECEMBER 19.

CHEMICAL SOCIETY, at 8.30.—Derivatives of Tetramethyl Glucose: J. C. Irvine and A. M. Moodie.—The Characterisation of Mercerized Cotton:

Preliminary Note: J. Hübler.—Attempted Synthesis of β -N- β -Dinaphthacridine: Condensation of Methylene Dichloride and *o*-Substituted 2-Naphthylamines: A. Senier and P. C. Austin.

LINNEAN SOCIETY, at 8.

INSTITUTION OF MINING AND METALLURGY, at 8.

INSTITUTION OF ELECTRICAL ENGINEERS, at 8.—Electrical Power in Railway Goods Warehouses: H. Henderson.

FRIDAY, DECEMBER 20.

INSTITUTION OF CIVIL ENGINEERS, at 8.—The Mechanical and Thermal Efficiency of a Petrol Engine: L. G. E. Morse.

INSTITUTION OF MECHANICAL ENGINEERS, at 8.—Notes on the Manufacture and Upkeep of Milling Cutters: Dr. H. T. Ashton.

CONTENTS.

PAGE

An Upper Cretaceous Flora. By D. H. S.	121
Paper Mill-Workers and Technology	121
Local Ornithology	122
Electrical Engineering	124
Our Book Shelf:—	
Ade: "Modern Lithology, illustrated and defined, for the Use of University, Technical, and Civil-Service Students."—G. A. J. C.	125
Adam: "Inflammation. An Introduction to the Study of Pathology."—Prof. R. T. Hewlett	126
Hepworth: "Notes on Maritime Meteorology"	126
Letters to the Editor:—	
Mulatto:—Sir W. T. Thiselton-Dyer, K.C.M.G., F.R.S.	126
Specific Stability and Mutation.—R. H. Lock; Sir W. T. Thiselton-Dyer, K.C.M.G., F.R.S.	127
The Winding of Rivers.—Dr. John Aitken, F.R.S.	128
May Gossells. (<i>Illustrated</i>).—Rev. John Griffith	128
A Fishing Trip to the Gulf of Mexico. (<i>Illustrated</i>). By L. W. B.	128
Greek Archæology. (<i>Illustrated</i>). By H. R. Hall	129
The Future Water Supply of London	131
Notes	132
Our Astronomical Column:—	
Photographs of Jupiter's Satellites VI. and VII.	137
Temperature Control of Silvered Mirrors	137
Orbits of Spectroscopic Binaries	138
Mellish's Comet 1907	138
Solar Prominences in 1906	138
Search Ephemeris for Comet 1907a (Giacobini)	138
Prizes Awarded by the Paris Academy of Sciences	138
The Journal of the Royal Anthropological Institute	139
Experiments on Wind-Pressure	139
University and Educational Intelligence	140
Societies and Academies	141
Diary of Societies	144

THURSDAY, DECEMBER 19, 1907.

MATHEMATICS IN BOTANY.

Mathematische und mikroskopisch-anatomische Studien über Blattstellungen. By Dr. G. van Iterson, Jun. Pp. xii + 331 + plates. (Jena: G. Fischer, 1907.) Price 20 marks.

THE subject of Phyllotaxis, which formerly involved the study of the arrangement, though now more particularly the mode of origin, of the lateral members of a plant-shoot, since it was first placed on a scientific footing by Bonnet in 1754, has afforded one of the most fascinating branches of botany, and, it must be frankly admitted, one which is very inadequately treated in text-books; this being again the expression of the fact that the more that is known with regard to it, the more complex do its problems appear, and the more hopeless of final solution. The subject, again, possesses possibly a special interest in that it is strictly non-utilitarian, and remains a field of abstract scientific work dealing with some of the most fundamental questions of protoplasmic life, which attain but little emphasis in the animal kingdom, owing to the restricted output of systems of ramification and appendage-production in the more condensed type of animal-organisation. The literature of the subject is, however, very voluminous, and slowly increases, the present volume of Iterson being the only important contribution since the loss of Schumann, and the publication of some of the work of Church (1904).

In that the arrangement of lateral members in the case of shoot-construction usually involves phenomena of periodicity or rhythm, phyllotaxis becomes capable of a certain amount of mathematical treatment; and it is to this fact, perhaps, more than to any other that the subject is often viewed with a vague distrust by the majority of botanists; mathematical results can only follow from given premises, which must first be interpolated into the question; for example, Church pointed out in 1901 that the accepted usage for seventy years of mathematical expressions based on systems of regular helices rendered all discussions of the arrangement of members on growing apices purely nonsensical, and vitiated all deductions based on the apparent imperfection of such constructions. Some working hypothesis is clearly necessary to start with, and the assumption of different data may involve a completely different mathematical presentation. Iterson's volume, including 300 pages on the botanical aspect of the question, devotes 100 to mathematical speculations, the greater part of which will therefore not appeal to the average botanist at all. The mathematician necessarily starts with a severe handicap, since the data of the actual appearances presented at the apex of a vegetative shoot are so illusive. New primordia rise up as rounded pimples, wholly independent of the segmentation of the apex into constituent cells, and often without any visible connection with each other, yet falling along the paths of what is often a very elaborate pattern, most readily defined as a meshwork of intersecting radiating curves; and

it is admittedly impossible to measure any lines or angles, or even to plot the form of the actual primordium with any such degree of accuracy as a precise mathematical presentation would appear to demand; hence observers who are more familiar with the conditions obtaining at a growing-point become naturally suspicious of mathematical speculations which are incapable of verification.

In all the speculations which have been introduced into the subject, the difficulty is to find anything whatever which can be established as a reasonable proof of the working hypothesis selected; thus in Dr. Iterson's volume, models of spheres in helicoid or conical arrangements may edify the beginner, but they have no particular relation to the origin of leaf-primordia on the surface of a shoot-apex; systems of circles in tangential contact must remain unsatisfactory while there is no evidence that primordia can be treated as circles, or that the tangential contact is absolute; the mathematics of a conical surface which can be unrolled has little reference to the curved dome of a plant-shoot, the curve of which is beyond present calculation, while any unrolling of the systems destroys the only essential feature of the system of intersecting curves; again, the projection of a spherical primordium to a "folioid" curve gives suggestive imitative results, when these folioid curves are continued in a log. spiral system; but there is no evidence to connect the folioid with the shape of a leaf-primordium; and it does not, as a matter of fact, fulfil the normal demands of a phyllotaxis-system.

Writers on phyllotaxis in the past may be divided into three categories: first, those who seek merely for a method of simply enumerating and cataloguing the phenomena observed in the beautifully rhythmic patterns, usually expressed as spiral curves, in plant-shoots and buds, familiar examples of which are observed in the Pine-cone and the arrangement of the disk-florets of Composites. For these the empirical helical formulæ of Schimper and Braun (1835) still afford a sufficient basis, so long as observations are restricted to adult structures, and no very rigid accuracy is required. A second class of writers start off on the attempt to *imitate* the appearances, hoping thereby to explain them; the most unscientific line of approach conceivable, the physiological fallacy of such mimetic methods having been fully exposed by Sachs. To this line of argument botany is indebted for numerous theories of "torsion," since torsion will give a spiral effect! Such imitative conceptions culminate in the contact-pressure theory of Schwendener. Lastly, there is a more modern class of investigators who require something more fundamental, in the nature of a physical cause for the phenomena of rhythm, which clearly lies behind the first visible rise of rounded primordia, these being but the expression of more concealed growth-factors.

The treatise of Dr. Iterson, who apparently remains in the imitative line of approach, may be briefly described as an attempt to harmonise the largely accepted theories of Schwendener and older writers with a corrected mathematical presentation which in itself renders the difficulties of these writers largely illusory; as in the case of these observers, Iterson gets little

further than the expression of certain facts of general observation, which in themselves constitute no proof. Schwendener's theory of the influence of mechanical contact has long held the field, in spite of the fact that no such contact can be invariably proved to exist, or even to exert any mechanical action; so much so, in fact, that it has been regarded as possible to dilute the theory to one of vague "stimulation." Dr. Iterson, by following along the well-worn paths of previous observers, has reached very similar conclusions; and it must be admitted that continual study of the best exhibitions of the uniform construction of vegetative shoot-systems naturally impels the observer to the old and familiar view of Hofmeister, that appendages cannot help themselves, but arise in the next "widest gap" between pre-existing ones, as they are seen to do; such a statement represents no solution of the problem, but is, in fact, a confession of failure.

On the other hand, by approaching the subject from the standpoint of floral ontogeny, in which the most complex phyllotaxis-systems can be observed developing before one's eyes according to a perfectly defined architectural plan, in which the relation of the individual members may, however, be practically anything whatever, wide gaps being left in some places, spirals mixed with circular construction, and members apparently "omitted," as well as appearing "out of their turn," an investigator equally inclined with Schumann to the view that contact-relations present no contributory cause whatever to the phenomena of the initial phases, which can only be referred to autonomous growth-impulses within the substance of the shoot-apex; a region which, consisting as it does of undifferentiated cell-units, is beyond further possibility of observation. Among the general conclusions for straightforward "constant-phyllotaxis," Iterson reiterates the stock considerations of "bulk-ratio," "contact-relations," and the principle of the "widest gap" (p. 291).

The fallacy of the widest gap has been exposed over and over again; it is sufficiently obvious to the unprejudiced eye in the appearances presented at the apex of the common Fern, or shoots of Water-lilies; primordia do not invariably arise in close contact with each other, but may be widely spaced out at first. The same want of contact, or any connecting sequence between one series of members and the next, is a common phenomenon in floral ontogeny which also includes cases of such absolute irregularity that the necessity for a "mechanical law" for their production becomes an absurdity; while in examples of perfect regularity of construction, the case of extreme mathematical interest centres in those few instances in which successive whorls do not fall into the gaps of their predecessors at all, but are accurately superposed; such cases occur in certain living species of Mesembryanthemum, though the significance of this formation in the case of fossil plants may still be open to question. It is thus a matter for regret that Iterson should revive the conceptions of "close-contact" and "widest-gaps," which have seen so much service in the past; while again the conception of "bulk-ratio," or the relative size of the primordium with

regard to the axis on which it is "inserted," though extremely useful in dealing with the difficulty of distinguishing between systems which involve numerals of the same summation series, e.g. 3:5:8, &c., can yield no practical solution of the difference, for example, between a 3:5 construction and a 3:4, or, again, of the essential difference between spiral and circular arrangement. It is also sufficiently obvious that the causes which determine the relative rates of growth (which lie behind the relative size) must have existed in the actual substance of the growing-point some time before the primordia became visible to the eye as a definite outgrowth, and, admitting the absence of any necessity for close-contact, the spacing of the new centres of growth is presumably more important than their actual size; once the centres are initiated, the new growth-impulses from them are continued until they ultimately make lateral contacts as a wholly secondary phenomenon.

Dr. Iterson's volume affords an admirable introduction to the subject, and most of the branches are indicated; considerable value attaches to the *résumé* of the theories of Schwendener and Celakovsky, copiously illustrated with excellent figures (more than 100 text-illustrations, and 16 plates); these bear sufficient witness to the enthusiasm of the author in this most absorbing field of speculation, though when all is said we appear to be no nearer the solution of the problem than ever; it only gains in complexity where it seems to be most regular and simple; since an absolutely irregular construction can clearly have no explanation at all, it simply grows as one sees it grow, and can neither be accurately described nor imitated. To those who seek for the inner and ultimate cause of the phenomena, the subject still presents an indefinite field of research.

Few botanists appear to realise the extent to which a proper appreciation of the subject of phyllotaxis is involved in the morphological consideration of plant-growth, and floral construction and even phylogeny; the marvellous standpoint that a dimerous flower is simpler, and therefore more primitive, than a trimerous one, and a trimerous than a pentamerous, constitutes one of the vitiating factors of the systematic work of Eichler, and is still reflected in the modern German school of classification.

ORGANIC CHEMISTRY FOR MEDICAL STUDENTS.

Text-book of Organic Chemistry for Medical Students.

By Dr. G. v. Bunge. Translated with additions by Dr. R. H. A. Plimmer. Pp. ix+260. (London: Longmans, Green and Co., 1907.) Price 6s. net.

THE rapid advance which has marked the progress of physiological chemistry in the last twenty years, owing mainly to the remarkable researches of Prof. Emil Fischer, has emphasised the necessity of a sound knowledge of organic chemistry for all students of medicine. But organic chemistry has undergone developments in many other directions, and new compounds have multiplied at a most bewildering rate. It is clearly undesirable for the student of medicine to become acquainted with any

large proportion of the hundred thousand compounds which organic chemistry is said to include. He might, after a firm foundation had been laid, study with advantage only those special subjects which come within his sphere of interest. He cannot very well know how to select these for himself, and Prof. Bunge has therefore attempted to do it for him.

On the whole, Prof. Bunge has been very successful in the choice and arrangement of his materials, and has produced an eminently readable book. But the task cannot have been an easy one. In a small volume of 250 pages, which is assumed to start with the rudiments and finishes with such complex vital products as the purines, the proteins, and the alkaloids, there is a danger that the treatment may be diffuse and superficial. But though this is certainly not the case, it must be confessed that some preliminary knowledge of analysis, molecular-weight determinations, and especially about methods of studying structure, is desirable, if not indeed necessary, if the subject is to be understood. In support of this it may be pointed out that the structural formula of oxalic acid is given on p. 2, of glyceric aldehyde and dioxyacetone on p. 5, and of hippuric acid on p. 8, without any previous reference to Kekulé's structural laws. But this appears to be the only serious defect, and one which the student can easily remedy by a little preliminary study.

The chapters are written in a manner well calculated to stimulate the reader; indeed, no organic text-book within the writer's knowledge is so full of human interest. The following few errors have been noted:—Chlorine does not convert aldehyde into chloral, but mainly into butyl chloral (p. 50). It is not true that "no one has yet succeeded in obtaining directly by synthesis either a *d*- or a *l*-compound" (p. 79). On the contrary, *asymmetric synthesis* is an accomplished fact. A racemic compound and a mixture of enantiomorphs are not synonymous, and the difference is indicated by *r* and *dl* (p. 89). The author refers to the separation of synthetic tartaric acid into its *d*- and *l*-components by Jungfleisch as causing a great sensation, "for up to that time many chemists thought that optically active compounds could only be formed by the living cell" (p. 89). There must surely be some confusion here, for did not Pasteur resolve racemic acid? Pasteur, it is true, considered asymmetric synthesis, or the formation of one enantiomorph without the other, as a peculiar property of living matter, but that is another thing altogether. Finally, on p. 147 occurs the old story of Wöhler's discovery of artificial urea in 1828, a date which tradition and the text-books have fixed upon as that of a two-fold event—the first organic synthesis and the downfall of the vital-force theory. In reality it was neither the one nor the other, and perhaps the following observations may help to put the matter in a clear light.

The preparation of natural products in the laboratory began before Wöhler was born, for in 1776 Scheele obtained oxalic acid by oxidising sugar. Doebereiner's preparation of formic acid from tartaric acid in 1822, and Hennel's synthesis of alcohol from olefiant gas were both prior to

Wöhler's discovery. That Doebereiner's discovery received contemporary recognition is evident from Berzelius's reference to it in the *Jahresbericht* for 1823. "Doebereiner," he says, "has made the remarkable discovery that formic acid may be produced artificially." Now Liebig, in his treatise of 1840, falls into a curious error, which may lie at the bottom of the text-book myth. In reference to formic acid he writes, "Doebereiner was the first who prepared it by chemical means," whilst in another place he says, "Wöhler found a way of obtaining urea artificially, and it was the first substance formed in the animal-life process which had been successfully reproduced by chemical means." Now formic acid is as much a product of the animal-life process as urea, and no real distinction can be drawn between them.

It is clear, therefore, on Liebig's own showing, that of the two artificial products, Doebereiner's has the prior claim. How little Wöhler's discovery served to remove the belief in a vital force is very clearly indicated in Gerhardt's "*Précis de Chimie Organique*," published in 1844.

"A number of animal and vegetable substances have been reproduced by acting with oxygenating agents on more highly carbonised compounds . . . thus, the chemist has followed a path entirely opposed to that pursued by vegetable life . . . one need not therefore feel astonished that he has not yet produced cerebral matter, nor the constituents of the blood, nor equally complex substances."

Thus the vital-force theory did not suddenly collapse, as generally stated; on the contrary, it died a slow and lingering death. We may, indeed, ask, is it quite dead yet? For to quote the words of an authoritative contemporary writer, "the testimony of pure chemistry cannot as it at present stands be legitimately interpreted into a direct negation of vitalism in any form."

There only remains to add a reference to the work of the translator. Dr. Plimmer has not only rendered the German into excellent English, but has added very considerably to the text. J. B. C.

OUR BOOK SHELF.

- (1) *Some Nature Biographies: Plant, Insect, Marine, Mineral*. By J. J. Ward. Pp. xvii + 307; illustrated. (London: John Lane, 1908.) Price 5s. net.
 - (2) *The Fairyland of Living Things*. By R. Kearton. Pp. viii + 182; illustrated. (London: Cassell and Co., Ltd., 1907.) Price 3s. 6d.
- (1) MR. WARD'S little work, which consists of a series of articles originally published in the *Strand*, *Pall Mall*, *English Illustrated*, and other magazines and periodicals, may be regarded as a kind of cinematograph in book form, and may be unreservedly commended to all nature-lovers. One great feature of the several life-histories is that they are in the main based on actual personal observation, and that, too, of a kind which demands constant attention and the expenditure of no inconsiderable amount of time. In his preface the author very modestly suggests that he is entitled to the credit of being the pioneer in certain forms of insect photography, and to this credit, so far as our information goes, he is fully entitled. Nothing in nature-photography can, indeed, be more interesting than his pictures of the sequence of events which herald the complete liberation of the butterfly or the moth from its chrysalis,

or of the marvellous evolutions of the caterpillar of the swallow-tail when about to pupate. As the author very pertinently remarks, to obtain photographs of this description the artist has in most cases only a single brief opportunity; and if one single link in the chain be missed, the whole series of pictures is spoilt. Needless to say, the reader sees only the successes; the failures are labour lost.

Among such an excellent series, it is difficult to select particular figures for mention, but those of the white admiral butterfly are especially noteworthy. Equally instructive and interesting are the photographs of developing and retrograding vegetable-life; more especially those connected with the fall of the leaf—a progress of which comparatively few persons know the physiological history.

The senses of insects, illustrated with exquisite pictures of antennæ and the fly's "tongue," form another chapter. The book closes with 12 photographs representing the monthly changes in a landscape as seen from one particular spot—a fuller development of the idea of photographing particular trees in summer and again in winter. A better book of its class we have never seen.

(2) In the "Fairlyland of Living Things" Mr. R. Kearton, aided, as usual, by his brother's camera, offers an attractive Christmas book, which should delight many households of young people. In place of confining himself to birds, the author includes in his purview quadrupeds (both hot- and cold-blooded), insects, and plants, and endeavours to interest his *clientèle* by dwelling on habits, instincts, and character rather than by describing structural details. Whether the author has touched the right note must be left for the class of readers to whom he appeals to decide; but we have never yet seen a "Kearton book" that has not proved a success. R. L.

Physiologisches Praktikum für Mediziner. By Prof. Max Verworn. Pp. xii+262; illustrated. (Jena: Gustav Fischer, 1907.) Price 6 marks.

THE practical class in physiology as known in this country has never been adopted to the full in Germany. There each student works out his own salvation by independent laboratory work, and research is started at an early stage in his career, as a means to teach him methods and resource. Elaborate German handbooks have been written as guides to such workers, most of them dealing with one branch of physiology, and not with all.

The aim of Prof. Max Verworn has not been to write an ambitious work of this character, but to furnish the average medical student with a guide to certain fundamental exercises, most of which it ought to be possible for each one to perform for himself, possibly in a class, as is the English custom. The remainder are appropriate for demonstrations.

In such a book it is obvious that there should not be over-specialisation, and thus we find in the subject, say, of the blood the study of its circulation closely following on that of its chemistry. In this way the various chapters see-saw between chemical and physical matters. In a theoretical book this is an ideal plan, but for a practical guide it has its drawbacks. Prof. Verworn is so well known for his writings on cells and what he terms "general physiology" that it is not surprising to find that some of the opening pages deal with this branch of science, and simple exercises on galvanotaxis, chemotaxis, and the like are introduced.

In some cases the directions are purely practical, and the descriptions of certain simple dissections are most precise. In other cases, theoretical matter and explanations are interspersed. These necessarily deal

with the subject very briefly, and the very briefness is in some cases apt to cause bewilderment. The description of the causes of blood coagulation cannot possibly be clearly given in a single short paragraph.

On the practical side we are surprised to find a study of the pancreatic juice omitted, and on the theoretical side no allusion is made to Emil Fischer's work on the ultimate cleavage products of the proteins. Some passages read as though the action of pepsin and trypsin stopped at the albumose and peptone stage. Surely every student nowadays must know something of polypeptides and amino-acids.

The illustrations, as a rule, are clear and judiciously selected, but the diagram of the absorption spectrum of hæmoglobin is very imperfect; indeed, the whole subject of blood spectroscopy is given in the merest outline.

Every teacher has, of course, his own ideas on the relative importance of the different parts of his subject; it is even possible that another reviewer might commend what the present one feels inclined to criticise. Two actual errors are, however, present; one is that fibrin is spoken of as a calcium compound of fibrinogen; the other is found in the description of the Adamkiewicz test for proteins, the colour reaction being described as due to the carbohydrate radical, whereas it has been proved to be due to tryptophan. W. D. H.

River Discharge. By J. C. Hoyt and N. C. Grover. Pp. viii+137. (New York: John Wiley and Sons; London: Chapman and Hall, Ltd., 1907.) Price 2 dollars.

WE have from time to time directed attention to the hydrographic survey that has been in operation for several years by the Geological Department of the United States Government. This survey is for the purpose of ascertaining the water resources of the country available for domestic use, irrigation or power.

The authors of the book now under notice have both been engaged in the survey work, and give in a thoroughly practical and useful way the result of their experience, and of the methods adopted in carrying out the work.

The information both as to the methods and the instruments used should be of great value to engineers engaged in hydrographic work and to students. The text is accompanied by twenty-four illustrations showing the various forms of current meters in use, the method of rating these, the floats used, the cables and cages used for obtaining velocities across wide rivers, weir stations, &c.

The book is divided into six chapters, dealing respectively with rainfall and evaporation; instruments used for obtaining velocities and depths; cable-station equipments; wading stations; theory and practice of measuring discharges; weirs and weir formulas; discussion and use of data; together with seventeen tables for facilitating the computations in various hydraulic problems.

Constructions in Practical Geometry. By the Rev. H. F. Westlake. Pp. viii+50. (London: George Philip and Son, Ltd., 1907.) Price 1s.

A COLLECTION of simple geometrical constructions without proofs, which is said to represent the minimum knowledge of the subject required of candidates in the Oxford and Cambridge School Examinations, is here provided. All the work can be done with a ruler and pair of compasses. The diagrams are clear and the instructions simple. A boy of twelve years of age should have no difficulty in mastering the course of work.

LETTERS TO THE EDITOR.

[The Editor does not hold himself responsible for opinions expressed by his correspondents. Neither can he undertake to return, or to correspond with the writers of, rejected manuscripts intended for this or any other part of NATURE. No notice is taken of anonymous communications.]

The International Memorial Statue of Lamarck.

The subscription list for the purpose of erecting a statue of the great French naturalist Lamarck in the Jardin des Plantes, Paris, where he did much of his work, will shortly be closed.

English men of science will, it is hoped, realise that it is now time to send subscriptions in order to show their regard for the memory of the great man whose name stands by the side of that of Darwin as a philosophical naturalist.

Subscriptions of any amount may be sent at once to me at the Natural History Museum, Cromwell Road, S.W.; their receipt will be acknowledged, and the subscriptions sent to the committee of French naturalists who are collecting funds, and will issue a list of subscribers; or subscriptions may be sent direct to Prof. Edmond Perrier, director of the museum, Jardin des Plantes, Paris.

E. RAY LANKESTER.

British Museum (Natural History), Cromwell Road, London, S.W.

Mulattos.

MAY I have a line to correct Sir William Thiselton-Dyer's impression (p. 126) that the tragic story of The Pure White Mother and the Coal-black Babe was accepted by me "as accurate and in perfect good faith"? I suppose I ought to have underlined the gentle sneer at a blackness transcending the natural blackness of a negro baby. At any rate, I told the anecdote simply to illustrate the nonsense people will talk under the influence of race mania, and I hope it will not be added too hastily to the accumulation of evidence on the Mendelian side.

H. G. WELLS.

Nest Eggs of Platypus.

My attention has been directed to the review of Mr. le Souef's book on "Wild Life in Australia" (NATURE, October 24) and to the reviewer's subsequent note on the eggs of Platypus (NATURE, November 28). The reviewer states that there "appears to be no definite evidence that the eggs" of Platypus "are really laid entire." As I had the good fortune to find some in that condition a few years ago, I think it well to record the fact. I have already shown these eggs in Sydney and to the British Association (1899), the Royal Society of Edinburgh, and other scientific bodies, but, alas! I have not found time to write a full account of my material, and I have been putting off—perhaps too long—in the hope of getting sufficient leisure for the task.

In September, 1897, I visited Gayndah, in Queensland, in search of the eggs of Ceratodus and Platypus. I had at once abundant success as regards the Ceratodus material, and so was tempted to devote most of my time to it. I shot a few specimens of Platypus, however, and did a little digging for eggs, without finding any. I did, nevertheless, have success of a kind with Platypus. On the last day of my fortnight in the district (September 20) I managed to find a nest with an adult female Platypus and a young male $\frac{5}{8}$ inches in extreme length. The mode of finding was both interesting and instructive. My two men and I, after trying several burrows in vain, came on the productive one. After following it for about 10 feet we reached the "breathing hole"; after another 7 feet we came to an apparent end of the burrow, and were greatly disappointed, as we had seen clearly the wet and inwardly directed footprints of a Platypus all the way from the external opening. One of the men groped about eagerly for any sign that the Platypus was working away from us, and finally we were able to track the burrow—filled though it was—through the hard surrounding soil. It

soon appeared that the tube had only been blocked for a short distance by loose soil, which was doubtless of use in keeping out intruders. After a short distance we got beyond the plug, and came again to an open passage. Fully 21 feet from the bank we came upon the nest. It was just large enough to permit of the adult Platypus turning in it. The top was about 9 inches above the bottom, and was about a foot from the surface of the soil. The nest itself was made of bark, leaves, &c. The mother and her offspring were quite buried in the material of the nest.

In 1898 I was again able to spend a few days in Gayndah, and I secured several uterine eggs from Platypus and three entire nest eggs. On August 31 I got two nest eggs adhering together, each of them about 15 mm. in greatest diameter. The eggs were perfectly intact, and the shells firm. The embryos were far advanced, and measured about 1 cm. in length.

On September 1 I got another intact nest egg and a female adult at the end of a burrow. The embryo in this egg was even more advanced than in the others.

I secured about the same time several nest embryos, and I was inclined to think that my visit was rather late in the year for nest eggs.

I may add that, as a rule, in following a productive burrow I had to work through one or several "plugs." It would seem as if the mother Platypus, even when at home, adopts the same method of securing safety as rabbits make use of when leaving their young in a burrow.

Queen's College, Belfast.

GREGG WILSON.

Sulphur as an Insulator.

The gold-leaf electroscope, simple as it is, has proved itself to be an excellent instrument for showing the properties of static electricity; but usually it has this drawback, namely, that it does not retain an electrical charge at a constant value for a conveniently long period of time. Recently an aluminium-leaf electroscope has been tested by me for insulation; the results, which speak for themselves, may be of interest to others who employ this electrical instrument. The electroscope was designed by Prof. J. S. Townsend, F.R.S. Its excellence depends on the metal leaves being supported by means of sulphur. The appended table shows how it behaved during ten days, on many of which rain fell, and from the air in the room where the experiment was made moisture was freely formed on bottles and metal instruments. Each division indicates a potential difference of 100 volts. The charge was positive; * indicates rain:—

Date	Time	Divisions	Date	Time	Divisions		
* Nov. 26	11 a.m.	8.0	Dec. 1	Noon	4.0		
* "	27	11 a.m.	7.0	"	1	6 p.m.	4.0
* "	28	Noon	5.0	* "	2	Noon	3.5
* "	28	6 p.m.	5.0	"	2	6 p.m.	3.5
"	29	11 a.m.	4.75	"	3	10 a.m.	3.0
"	30	11 a.m.	4.5	"	4	11 a.m.	2.75
"	30	6 p.m.	4.25	"	4	3.30 p.m.	2.5
			"	5	Noon	1.0	
			"	6	6 p.m.	0.0	

I have also a quadrant electrometer having a long suspension of metal ribbon. All parts of this instrument are supported on pure sulphur; an experience lasting over many years has proved the excellence of sulphur as an insulator. Of course, an instrument so constructed requires careful handling, but when once erected in a suitable niche it will be found to give hardly any trouble and to keep its charge well. It seems somewhat strange that with some few and noteworthy exceptions, sulphur as an insulator should not be more frequently employed in the physical laboratory at the present day, as its excellent qualities were known and utilised in the early days of electrical science before 1797 by Wilcke, Gëpinus, Henley, and others. I may add, in conclusion, that in the construction of the interesting little electrical dry pile apparatus, whereby a small bell has been constantly struck for forty-two years in the Clarendon Laboratory, Oxford, sulphur was employed as the insulator.

F. J. JERVIS-SMITH.

NOTES ON ANCIENT BRITISH MONUMENTS.¹

III.—Some Measurements in South Wales.

THANKS to the kindness of the Rev. John Griffith, Col. Morgan and other friends, I was enabled last August to visit several monuments in South Wales.

I had previously inquired of persons living in North Wales about the existence of cromlechs and other memorials of the past in that region, and had been informed that they were very rare; but before my visit to Swansea the Rev. J. Griffith had told me that he personally knew of forty cromlechs in South Wales, so one would suppose that the conditions are very different in different parts of the Principality; but this does not appear to be so, for I have since found that Anglesea is richer in these monuments than Glamorgan. Perhaps the explanation is that there is little general interest taken in these matters.

The most important cromlech I visited under the

For Sir Gardner the cromlech was a great tomb, as his description will indicate:—

"The great cromlech, called Arthur's Stone, stands on that part of the hill called Cefn Bryn in Gower, which is an outlying branch projecting from the north side of the main ridge Cefn, or 'backbone'; and the great number of carns in that locality show that it was selected as the most appropriate spot for the burial of the dead in early British times. For though several carns, or tumuli, are found on other parts of the hill, they are more scattered, and evidently occupy positions not so peculiarly chosen for the purpose."

He next refers to the avenue.

"Near to the great cromlech is a line of four, or perhaps five, stones, standing at irregular distances from each other, and in a direction nearly east and west, which has every appearance of being the remains of an avenue. If so it passed a little to the north of the cromlech; and though these stones only form a

portion of one side, or of one row of that avenue, some of the corresponding stones may be traced on the other side, and give the avenue a breadth of about 49 feet. The five most conspicuous stones on the north side may be the isolated remains of a great number which once stood there, the intervals between them being respectively 165 feet, 79 feet, 149 feet, and 107 feet; and the whole length of the line, from the most easterly to the westernmost stone, nearly opposite or to the north of a drive or grass road ap-



FIG. 10.—Arthur's Stone.

auspices I have mentioned was that of Maen Ketti, or Arthur's Stone, in Gower, whither we motored from Swansea.

The antiquities in this region, which are very numerous and important, and include the remains of one or more avenues as well as the cromlech, were carefully studied by Sir Gardner Wilkinson.²

In his most interesting account of them he begins by pointing out the important place the cromlech itself occupies in Welsh tradition:—

"If the Greeks recorded the 'wonders of the world' in their time, under the mystical number seven, four of which might be claimed as their own, the Cymry have also recorded the wonders and mighty labours of the Britons in one of their Triads under their favourite, an equally mystical, number three: namely, 1, raising the Maen Cetti; 2, erecting the work of Emrys; and 3, heaping the pile or mound, of Cyfrangon. The first of these is the stone of Cetti, or 'Arthur's Stone'; the second, Stonechenge; and the third, apparently, the mound called Silbury Hill, near Abury."

Apparently made there in later times, which passes to the north of the cromlech; and as the stone opposite the cromlech (the westernmost of the five above mentioned) is distant from it about 60 feet, this alone suffices to show that the avenue did not run direct to that monument. It is difficult to determine whether a corresponding line of stones formerly stood on the opposite or south side, so as to form a real avenue; but even if this were so, the avenue would not, as we have already seen, lead to, but past, the cromlech, as the grass road does at the present day. It is also difficult to decide whether the road has taken the place of an older one, once the centre of the avenue, or is a drive of entirely recent origin made for the purpose of passing near the cromlech, and round the great carn beyond it to the west; whence it continues over the adjoining part of the hill. It certainly has the usual appearance of old paths, such as we find in the vicinity of ancient ruins, the grass being short and smooth; though this may have been caused by the removal of the fern and furze, and the constant use of the road after it was formed into a drive. It is, however, reasonable to suppose that the few stones, which stand here and there to the south of the grass road, constituted part of the corresponding side of the

¹ Continued from p. 84.

² "Avenues and Cairns about Arthur's Stone in Gower," by Gardner Wilkinson ("Arch. Cambrensis," fourth series, vol. 1, pp. 27-45).

avenue, though the intervening distance of 49 feet (6 feet more than the width of the eastern avenue at Abury) may appear an unusual breadth for one, the stones of which do not exceed 3 feet to 3½ feet in height. I may also state that other stones appear here and there, on both sides of the grass road, beyond the limits of the portion of the avenue marked by the five stones, which may be a continuation of the same double line to the east and west. They would not, however, be sufficiently conspicuous to suggest the existence of an avenue, if the five stones had not been present to prove it. Many also stand at the extreme end, to the south-east, where the first carns are met with on this part of the hill."

Next follows a statement which shows what a keen and practised observer Sir Gardner was. Had I known of it earlier it would have saved me much trouble.

"I need scarcely observe that it is by no means necessary that the avenue should lead direct to Arthur's Stone, and it is more usual to find a cromlech at one side of, and at a short distance from, it; that near Merivale Bridge, on Dartmoor, stands about 50 feet to the south of the avenue, and the Dolmens in Brittany are, in like manner, placed outside the avenue. A carn also stands about 80 feet south of the same avenue near Merivale Bridge; but about 560 feet west of the cromlech, in the centre of the avenue, is a concentric carn, of which the diameter is about three times the breadth of the avenue. The position of Arthur's Stone with respect to the avenue is, therefore, similar to that of some other cromlechs in this country and in Brittany, but while we see that the avenues of Merivale Bridge, and in some other places on Dartmoor, terminate in an upright stone, a carn, a concentric aisle, or some other sepulchral monument, we are unable to ascertain how the two ends of the Cefn Bryn avenue were closed or to what they led."

The avenue, which was perfectly obvious, lay on our way to the cromlech, so I measured it first. The azimuth (magnetic) to the south-east was S. 136° E., height of horizon 1° 30'. In the north-west direction the elevation of the horizon was 0°.

The cromlech from its state of wreckage was much more difficult to measure. The length of the quoit is roughly north-west and south-east, and the long faces are not parallel, and, indeed, a large mass has been detached, but the north-west side is pretty plane. I measured its direction as N. 82° E., and on examining the supporters as well as one was able, the opening of the cromlech appeared to lie in that direction. I have no note of the height of the horizon, but Mr. Griffith tells me that it is 'hilly, let us assume 1°.

Now what do these azimuths mean? I can answer this question best by giving the following table, which shows without any possibility of doubt that these Gower monuments, like those in Cornwall, deal with the May-year sunrises, the avenue with the rise in November, and the cromlech with the rise in May.

Gower, lat. 51° 37' N., variation 18° W. May-year values, theoretical.

Conditions	May		November	
	True	Magnetic	True	Magnetic
Sea horizon: refraction and semi-diameter ...	N. 62° E.	80°	S. 64° 40' E.	133° 20'
1° hill: refraction and semi-diameter ...	N. 63° 30' E.	81° 30'	S. 62° 33' E.	135° 27'
2° hill: refraction and semi-diameter ...	N. 65° 10' E.	83° 10'	S. 60° 58' E.	137° 2'

To compare theory with the actual magnetic observations we have:—

	Computed value	Measured
Avenue, November sunrise	136° 14'	136° 52'
Cromlech, May sunrise	51 30	

Need I say that these results of the first measurements made in Wales are very encouraging, and, more than that, *helpful*, because they show that the Cornish experience can be fully utilised, as we are dealing with no new thing.

Another cromlech we visited is one of great interest. I suppose its quoit is the largest in Britain. The north side is entirely closed by a large supporter; the south entirely open along its top; in the east and west ends there are openings. This large rectangular cromlech is situated in the parish of St. Nicholas in Duffryn Golych or Goluch (The Vale of Worship), near Cardiff. It is called by the natives Castell Corrig (Dwarf's Castle), a name which suggests belief in the presence of fairies there.

It seemed at first probable that this monument might have a high south-east alignment. Mr. Griffith noted the openings in the east and west supporters, and found the eastern azimuth of the north supporting slab to be N. 76° E. (true), with a height of horizon of 2°. This particular wall need not necessarily be parallel to the outlook of the cromlech, which for the May sunrise should be, as the previous table shows, N. 65° E. It is too early, therefore, to claim it as oriented, like Arthur's Stone, to that sunrise; we may be dealing with the Pleiades, but to settle matters some excavations and further measures are required, and I am glad to learn that the Cardiff Naturalists' Society has made arrangements with Mr. Cory, on whose estate the cromlech stands, for the necessary excavations in the spring of next year.

A few yards to the west of the large cromlech there are the remains of another not nearly in such a good state of preservation, but one side support is fairly in position, and, as I shall show later on, we are justified of taking this in the absence of more precise information.

The azimuth of this stone towards the E. is S. 51° E.

Evidently, then, we are not dealing with the May-year. Is it a solstitial cromlech? I give, as before, the theoretical azimuths.

Solstice azimuths in lat. 51° 30' for 2' of the disc showing above a sea-horizon, refraction being taken into account.

Summer solstice	N. 48° 42' E. or W.
Winter "	S. 51° 35' E. or W.

We see that the azimuth tallies exactly, so we must accept it as a cromlech directed to the winter solstice sunrise.

With regard to another cromlech, St. Lythan's, in the same neighbourhood, known locally as Gwâl y Vilast, "the lair of the greyhound bitch," the azimuth of the north stone, S. 88° E., shows it to have been oriented to the equinoctial sunrises in March and September. The cromlech opens to the east.

On a previous visit Mr. Griffith found outside the cromlech chamber a red sandstone pebble used both as a pounder and a rubber or burnisher. It may have been taken out of the chamber when the latter was uncovered or cleared out. It was right on top of the cairn shell, in which the chamber was once embedded.

I have now referred to all the sun-temples we found in our two days' inquiries. Both Mr. Griffith and

myself made measures of other monuments, but space fails me to refer to them now; still, I must make one exception.

We measured still another cromlech of very considerable interest, as in it we dealt with a presentation to the rise of a clock-star, and no longer to the sun. This is the remaining interior of a four-chambered barrow situated at Parc y Brnosse, or Parc Cwm, or the Green Combe. It was excavated by Sir John Lubbock, now Lord Avebury. The true azimuth is N. 8° E., the height of the horizon 6°. These data give us Arcturus 2600 B.C., a little earlier than the Cornish monuments with somewhat similar orientations.

It will be very instructive at some future day to compare the plans of the Castell Corrig cromlechs and that of Arthur's Stone with a view of determining the exact alignments of the supporters. I have already done this work on the plans of the Cornish cromlechs.

A study of Lukis's plans, especially of the stones still upright, brings out many interesting points, among them the fact that there were two general methods of building. One was to plant one or two stones in the exact direction of the alignment. The location of the other stones did not matter so long as the quoit was properly supported, but in many cases they were set up parallel to the directing stone, as we may call the first one erected. Another system was to support the quoit on a tripod. When this was done its greatest length was sometimes at right angles to the direction of orientation, this direction being indicated by the alignment of the single stone at one end.

It often struck me in Cornwall that the exact alignments, especially to the May-year sunrises, which really required a knowledge of the number of days which had elapsed since the last solstice, were the work, not of each local druid, but of peripatetic astronomer-priests who went from place to place establishing and orienting the circle and the priests' house (cromlech), and then leaving subordinate priest-druids—curates—in charge, who could not go far wrong when the alignment of both circle and cromlech fixed the May, August, November and February festivals; the solstices they could easily fix for themselves, because then the sun rose in the same place on three successive mornings.

The study of Lukis's plans shows that the work of the peripatetic priest might really have been limited in the first instance to the setting up of the single directing stone. Of course he would examine the finished work in his tours of inspection, probably at the critical times of the year—the quarter days.

I sent this suggestion some little time ago to the Rev. J. Griffith, who has greatly helped me by permitting me to draw upon his vast store of Welsh tradition. His reply really supplies us with a new line of evidence as to the tenancy of cromlechs by living men, in addition to those I have already put forward.

"I have spotted your travelling time-keeper, though I seem never to see anything unless you point out what to look for. He is very conspicuous in Welsh cave legends. There is the lonely watchman—your 'curate'—waiting and waiting for him. All over the country a couplet is known as having been uttered by the 'curate.'

'Long the day and long the night,
And long it is to wait for Aaron.'

Sometimes his name is Noah. It is clear why the pagan should have a Bible name; Aaron is the rationalised form of the name of a Welsh legendary hero—Aravn.

"In two cave legends the curate is heard exclaiming:—

'The hour is come, but the man is not.'

In one case it is the eve of New Year's Day.

"Who could the mysterious man be if not your peripatetic astronomer-priest? He was evidently very much wanted for the great festival. Your surmise or conclusion has lit up a round dozen tales I now remember, and doubtless I can find many more."

NORMAN LOCKYER.

THE INCREASED ENDOWMENT OF UNIVERSITIES.

WE are glad to see that the Press is again directing attention to the importance of an increased endowment of our universities, not so much, at the present moment, of the older universities as the younger ones. It is, in fact, the Government action in regard to Manchester University which has directed attention to the subject. That opinion is getting more enlightened is evidenced by the fact that it is now beginning to be recognised that the real gainer by such endowment as this is not any particular locality or university, but every student throughout the length and breadth of the land who is debarred by high fees from attending university courses, the university being compelled to charge high fees in order to go on at all in consequence of the absence of adequate income from any other source.

Here are some extracts from a recent article in the *Morning Post*, to take one instance:—

"It is necessary if the nation is to continue to be an independent Power to have a Navy able to defeat and destroy its rivals, and an Army able to do all such fighting, in case of war, as the Navy cannot do. But this necessity, of which no one is enamoured, does not absolve the Government from the duty of doing the very best it can for the training not only of the rank and file, but of the leaders of its population. Mr. Asquith will provide in his estimates some fifty million pounds for the needs of the Navy and of the Army. This of course cannot be reduced. For the modern universities and colleges that represent a great popular effort towards providing a better training for leaders than existed for the fathers of men now at work, and for many of those men themselves, Mr. Asquith cannot imagine that he ought to provide more than 100,000. But this sum might be increased without reducing the other. The fifty millions are unproductive expenditure. They are mere insurance, a disagreeable necessity. But the money spent on educating young people is the most remunerative outlay possible to a nation.

"The University of Manchester is the means, in most cases the only means, open to the inhabitants of a great area in South-east Lancashire, Cheshire, and part of Yorkshire, a population numbered by millions, of obtaining an education going beyond school work. It is admittedly among the best of modern universities, with a large staff of first-rate professors, an admirable set of buildings, and an assiduous, devoted, and capable governing body. It represents the chance of South-east Lancashire providing itself with leaders in industry, commerce, the sciences, and the humanities.

"Manchester may have to compete with some place like Berlin, the centre of a comparatively small population. Berlin does not limit its Government grant to university and other forms of higher education to such a sum as ten thousand a year, therefore, and Berlin tends to eclipse Manchester in the fields of industry, trade, science, art, and the humanities.

"Mr. Asquith knows as well as anyone else how many millions such men as Sir Robert Giffen and Sir Norman Lockyer think the British Government will have to spend on universities and colleges if England is to keep her place among the nations. They may talk, but he draws the

line at one hundred thousand pounds. But does he not see that the welfare of England and her people depends above all things on their personal character and qualities twenty years hence, on the kind of men and women that she is turning year by year into citizens and mothers?"

Mr. Asquith we suspect knows more of these matters than the writer in the *Morning Post* thinks. The Chancellor of the Exchequer, in speaking at the London Chamber of Commerce in November of last year¹ said:—

"The strain of foreign competition presses upon us in every walk of business and every market in the world, and, whatever are the contributory causes of the pressure which we all in a greater or less degree experience, there is not a man acquainted with the facts who will not agree that in the case, at any rate, of some of our most formidable competitors—for instance, Germany and the United States—one of the great sources from which they have derived exceptional strength in their commercial and industrial struggle with us has been the superior development of their technical and educational system."

But it may, after all, be that Mr. Asquith is unacquainted with the methods adopted by the German Government, to take one instance, to secure this superior development. German universities are considered by our statesmen as a *quantité négligeable*; all their attention is directed to the German ironclads. This is not so in Germany, as witness the increased endowment in fifteen years of some German universities taken at random:—

State Funds.

	1891-2	1906
	£	£
Berlin	107,057	161,539
Bonn	45,806	59,192
Breslau... ..	44,749	66,375
Göttingen	20,877	35,393
Greifswald	13,974	28,889
Halle	33,284	59,819
Kiel	28,188	53,072
Königsberg	39,930	57,344

The same growth of enthusiasm for higher education which is characteristic of German statesmanship is met with throughout the more densely populated eastern United States. When a comparison is instituted between the income of universities and colleges in the States in the year 1899-1900 and the income in 1904-5 (the latest year for which detailed official statistics have been published), that is fifteen years later, an enormous increase is found to have taken place. In the earlier year the total income of these institutions of higher instruction was 2,399,000^l, while in 1904-5 the amount had grown to 7,110,000^l. But large though these sums are, they take no account of the generous benefactions of American men of wealth referred to later. From this source the universities and colleges received in 1899-1900 2,399,000^l, while fifteen years later the amount given for the spread and development of higher learning reached the magnificent sum of 3,335,800^l. Harvard University alone received during the later year 466,000^l, Yale benefited to the extent of 279,000^l, and Columbia was enriched by 236,000^l. Figures such as these serve better than any words to exhibit the comparative insignificance of the 122,000^l, which, as we shall show, represents the total State endowments of English universities.

But British statesmen cannot be held responsible for the unpopularity of universities and colleges as the object in this country of the bequests and gifts of wealthy men and women. In the following table, therefore, benefactions are excluded, and the growth in the income of the universities of five important eastern States in America is given, as typical of the

advance made in the eastern half of the United States in the provision for higher instruction during the fifteen years under consideration.

Total Income, Excluding Benefactions.

	1899-1900	1904-1905
	£	£
Massachusetts	521,800	614,000
New York	705,700	981,300
Pennsylvania	390,100	534,400
Ohio	266,600	387,000
Illinois... ..	388,800	585,800

The decision of Mr. Asquith to reduce the grant of Manchester University from 12,000^l to 10,000^l a year, we presume, is based on the stern argument that as little money as possible should be spent on the higher education; even although it is the true source of national development; it is a question, not of national, but of party politics.

In the case of party politics, of course, economy may be thrown to the winds. Mr. Haldane, when he opened the new college at Reading,² told us:—

"The present Government proposes to spend an extra 1,000,000^l a year on elementary instruction, and the late Ministry spent more than that sum additionally for the same purpose, but these payments arose out of controversies which had LITTLE TO DO WITH EDUCATION."

Dealing with the modest contribution of the British Government to the universities and colleges of England, the estimates show us that in 1903 the endowment of universities amounted to 14,800^l, which we find increased in 1907 to 22,000^l. In 1903 the grant to English colleges stood at 26,000^l. This has now been increased to 100,000^l, we believe in consequence of the strong representation made by the British Association deputation in 1904. It is seen that at present the total State endowment of the English universities—22,000^l + 100,000^l = 122,000^l.—is some 40,000^l short of the German State endowment of one university alone, that of Berlin.

We are told that to provide the "superior development of our technical and educational system," which even Mr. Asquith acknowledges is necessary to meet "the commercial and industrial struggle," we must trust to private endowment. Cambridge has recently asked for a private endowment to provide funds which the university wants at once. At the rate at which this private endowment has been coming in during the last few years, ninety years will elapse before all these funds are in hand. This is a fair sample of what private endowment does for university education in England, while the competing universities and colleges of the United States last year received nearly 5,000,000^l from this source,² every penny of which tended to reduce fees and extend the benefits of university instruction to a greater number of students, the peace army of a nation.

In addition to this it is important to remember that American experience all goes to show that the best results are obtained when universities are chiefly dependent on the State and not upon private generosity. It has been pointed out recently in the United States (*NATURE*, vol. lxxvii., p. 93) that as a result of the gifts of millions of dollars from great American financiers, the universities are in danger of being reckoned the purchased servants of a narrow caste. It is being urged here, as we have urged here, that it is the duty of the State to provide higher education for the people; and there is every indication that American authorities may be trusted to maintain the efficiency of their universities and colleges.

The increase in the efficiency of colleges and universi-

¹ *NATURE*, December 6, 1906 (vol. lxxv., p. 141).

² *NATURE*, November 1, 1906 (vol. lxxv., p. 22).

² *Ibid.*, January 3, 1907 (vol. lxxv., p. 137).

ties in this country is too pressing a need to be dependent upon party politics. Unless our statesmen can be made to realise the supreme importance of this matter and be persuaded to deal with it in a patriotic manner, generously and expeditiously, as if there were no votes to retain or secure, we must reconcile ourselves to the idea that as a manufacturing and distributing people we shall in due course have to occupy a third or fourth place among the nations of the world. In Germany, the United States, and now in Japan rulers have learnt the lesson that efficient education and industrial success are related to each other as cause and effect; and, moreover, they appear to be supported by an enlightened public opinion.

If our statesmen refuse to lead, we must make every effort to educate the voters of the country to realise the certain results of a policy of drift from which the most important of our national questions—so far as the future welfare of the British Empire is concerned—is suffering. If, meanwhile, our present supremacy is lost, it will not be because men of science have failed to warn their countrymen of the scientific spirit and energy which are yearly increasing the industrial efficiency of our great competitors.

NOTES.

ON the day of going to press we learn of the death of Lord Kelvin, an announcement which will be received with deep sorrow throughout the civilised world. To men of science, Lord Kelvin's achievements in the realm of scientific thought and discovery have long been familiar; and thirty-one years ago, in *NATURE* of September 7, 1876 (vol. xiv.), his remarkable contributions to natural knowledge were described in our Scientific Worthies series, of which he was then the subject. His death is a loss to science which only scientific workers can adequately realise. The world has to deplore the departure of a brilliant and inspiring figure; while science mourns that a leader whose influence has stimulated progress in many directions during a remarkable period has passed into stillness. For the body of one who has brought such honour to the British nation, the only appropriate place of burial is Westminster Abbey. We trust that steps will be taken at once to secure this mark of national recognition of the greatness of one who has long been regarded as the most distinguished man of science of modern times.

A LIFE of Lord Kelvin has been in preparation for some months by Prof. Silvanus Thompson, who was entrusted with this work, and to whom Lord Kelvin himself furnished numerous biographical details and other matter for the purpose. It will be published in the course of next year by Messrs. Macmillan and Co., Ltd.

THE Prince of Wales was elected an honorary member of the Royal Irish Academy at the last meeting of the academy. In the case of the election of a member of the Royal Family the election is by resolution, which was moved by the Earl of Aberdeen, Lord Lieutenant, who is the visitor of the academy, and seconded by Mr. D. H. Madden, Vice-Chancellor of the University of Dublin.

SIR NORMAN LOCKYER, K.C.B., F.R.S., has been unanimously elected president and an honorary member of the Penzance Natural History and Antiquarian Society in recognition of his services to the study of the circles and other prehistoric remains in west Cornwall.

M. EDOUARD CYVER has been elected president of the French Anthropological Society for 1908.

NO. 1990, VOL. 77]

Two lectures suitable for a juvenile audience will be delivered for the Society of Arts on January 1 and 8, 1908, at 5 p.m., by Mr. F. Martin Duncan, on "The Scientific Applications of the Kinematograph."

A COURSE of six lectures on the geographical distribution of rainfall in the British Isles will be given by Dr. H. R. Mill in the map room of the Royal Geographical Society on Thursday evenings in January and February, 1908, beginning January 23 at 5.30 p.m.

PROF. R. W. WOOD, professor of experimental physics in the Johns Hopkins University, has been awarded, *Science* states, the John Scott legacy premium and medal of the Franklin Institute of Philadelphia for his discoveries in colour photography.

THE Russian Physico-chemical Society has arranged to hold a conference of general and applied chemistry in honour of Mendeléeff at the beginning of January, 1908, at the University of St. Petersburg. Several discourses will be delivered on the great chemist's life and works. We learn also from the *Revue scientifique* that the journal *Russj* has inaugurated a subscription for the purchase of a Mendeléeff House, which, like the Hofmann House in Berlin, would be used for the meetings of learned societies.

THE eleventh International Congress of Navigation will be held at St. Petersburg from May 31 to June 7, 1908, under the patronage of the Emperor of Russia. The previous meetings were held at Brussels, in 1885; Vienna, 1886; Frankfurt-on-the-Main, 1888; Paris, 1889; Manchester, 1890; London, 1891; Paris, 1892; the Hague, 1894; Brussels, 1898; Paris, 1900; Dusseldorf, 1902; Milan, 1905. Arrangements have been made for communications and discussions on several questions relating to inland and maritime waterways, including the industrial and agricultural utilisation of rivers, and for scientific excursions and inspections of some of the rivers, canals, and sea ports in Russia. The address of the general secretary of the congress is 7 Ismailovsky Prospect, St. Petersburg.

THE current number of the *Revue Scientifique* contains an account of "La Caisse des Recherches scientifiques." The fund was founded by law on July 14, 1901, on the proposition of M. Audiffred, with the double object of assisting medical science in its researches and of providing financial assistance to original workers in pure science. The fund receives from the French Government an annuity of 5000*l.*, and at its inauguration M. Audiffred gave 2400*l.* The idea of the fund has not proved altogether popular, for in 1906 the Caisse des Recherches received general donations to the extent only of just under 200*l.* But there has been considerable improvement this year, and it is anticipated that the amount will be much larger; the Paris Municipal Council itself gave 200*l.*, and several general councils have given small sums. Since its creation the Caisse has distributed more than 24,100*l.*, of which about 1000*l.* only was available for work in other than medical and biological science. M. Rigaut may well say that these sums are wholly inadequate so far as the needs of science are concerned.

PROF. ASAPH HALL, whose death we announced last week, will always be remembered as the discoverer of the satellites of Mars, since the sensational character of the discovery appealed powerfully to the public mind; but in many ways he accomplished much useful work in every department of astronomy, and exhibited an industry which placed him in the forefront of American astronomers.

Diligence and energy were his principal characteristics from the time when he entered Harvard Observatory, as a junior, fifty years ago, until he retired from the honoured position of professor of astronomy in 1901. The greater part of his work, however, was accomplished at Washington, and it is difficult to say what department of astronomy he did not enrich. He was one of the earliest to appreciate the value of the observations of Mars as a means for deriving the solar parallax, and he took part in solar eclipse expeditions for physical work on the sun. His observations of planets, whether for position or for surface detail, were frequent and accurate. He was an industrious observer of double stars, and his work on stellar parallax, as well as in the determination of the relative positions of stars in clusters, is well known. On the theoretical side of astronomy he contributed papers on the secular perturbations of the planets, the computation of orbits, and many similar problems. As a geodetist, the value of his work in the determination of longitudes and on the employment of the occultation method has long been recognised. His career was that of a typical practical astronomer, and the recognition of his work was shown by his election into many learned societies. He was both gold medallist and foreign associate of the Royal Astronomical Society.

THE subject of river pollution from the naturalists' point of view was introduced by Prof. R. Meldola, F.R.S., at a largely attended conference meeting, convened under the auspices of the Essex Field Club, and held in the Municipal Technical Institute, Stratford, on Saturday, December 14. The Mayor of West Ham was in the chair at the beginning, and subsequently the president of the Essex Field Club (Mr. Miller Christy). Among other speakers upon the subject were Mr. E. B. Barnard, M.P. (chairman, works committee, London Water Board), Mr. David Howard, J.P. (past-president Society of Chemical Industry), Dr. Parsons (Local Government Board), Sir Alexander Pedler, K.C.I.E., F.R.S. (hon. secretary, British Science Guild), Sir William Ramsay, K.C.B., F.R.S. (president Chemical Society, and chairman Royal Commission on Sewage Disposal), Dr. Sanders (medical officer of health, county borough of West Ham), Dr. Sommerville (lecturer on public health, King's College, London), and Dr. J. C. Thresh (medical officer of health, Essex County Council). At the close of the meeting the following resolution was moved by Sir Alexander Pedler, seconded by Mr. E. B. Barnard, carried unanimously, and ordered to be transmitted to the Local Government Board and the British Science Guild:—"That this meeting, having heard the expert testimony of many qualified speakers interested in the improvement of the state of our rivers, streams, and water-ways, it is of opinion that legislative action is urgently needed, and would regard with satisfaction the creation of a central authority under Government for dealing with the general question of water supply throughout the kingdom, as well as with the disposal of sewage and of effluents from factories; such central authority to be given power to apportion expenditure on sewage treatment or other necessary work of purification amongst the communities deriving benefit from such expenditure."

British Birds for November contains an excellent portrait of the late Mr. Howard Saunders to illustrate an obituary notice by Mr. Abel Chapman. The portrait is also published separately by Messrs. Witherby and Co., price 1s. 6d. The other contents include a paper by Dr. E. Hartert on races of birds peculiar to the British Islands,

and a note by Mr. N. F. Ticehurst on the capture in Romney Marsh of a specimen of the American sandpiper, *Ereunetes pusillus*, this being apparently the first record of the species in Europe.

To the *Times* of December 14 Sir T. Digby Pigott communicates an account of a luminous bird—believed to be an owl—recently seen at night in Norfolk. The idea that the "powder-down" patches of certain birds are luminous has been held, we believe, in America, but is generally discredited by ornithologists. The circumstantial account of the Norfolk bird may, however, lead to a re-consideration of the evidence, although we cannot admit that the name *Strix flammea* has anything to do with the alleged phenomenon, as it almost certainly refers to the colour of the feathers of the back. The story that the heron emits a phosphorescent light in order to attract fish also seems "shaky," seeing that the bird is diurnal in habits.

At the close of a paper published in the November issue of the *Quarterly Journal of Microscopical Science* on the muscles of the head in birds (as exemplified by the domesticated fowl) and reptiles, Prof. H. F. Edgeworth attempts to formulate the leading anatomical features of the common ancestor of those two groups. The list is too long and too technical to be quoted here, but it may be noticed that in certain respects the author finds that birds have more in common with chelonians than with any other group of reptiles. "These features of resemblance suggest at first sight a very distant chelonian relationship for birds, but are in reality very ancestral traits, which are also present in embryonic stages of other sauropsidan groups. The secondary fixation of the pterygo-quadrate and atrophy of the elevator of the pterygoid process, which occur in Chelonians, are strongly marked differences from birds."

IN connection with the preceding note, reference may be made to a paper by Dr. W. Sippel on the structure of the roof of the mouth in birds and mammals, published in vol. xxxvii., parts ii. and iii., of *Gegenbaur's Morphologisches Jahrbuch*. The greater portion of the paper is devoted to the soft-parts of the palate, and it is shown at the conclusion that in homologising the constituent elements of this region in birds and reptiles several mis-identifications have been made by previous workers. The long, posteriorly widened median slit in the palate of the bird does not, for instance, represent the secondary choanæ, but rather the orbito-subchoanal cleft. The paper concludes with a comparison of the bones of the palate in reptiles, birds, and mammals, as illustrated by the monitor, the duck, and the dog, and here, too, some important differences distinguishing this region in the three classes are indicated.

IN the December number of the *Popular Science Monthly* Prof. Bashford Dean gives his impressions of the chief museums of Asia, as gathered during a recent eastern tour. Among the institutions referred to is the Raffles Museum and Library at Singapore, of which the author writes in terms of high commendation, the Colombo City Museum, the Madras Museum, and the Indian Museum, Calcutta. Dr. Willey's arrangement of groups of animals to give an adequate idea of the wild life of Ceylon is regarded as one of the great features of the Colombo Museum, while, under Mr. E. Thurston's administration, the institution at Madras is described as one of the most successful of its kind in India. The Calcutta establishment must, however, stand at the head

of all the museums of Asia, its success, in the author's opinion, being very largely due to the policy of selecting as directors men eminent, not only in science, but in administrative ability. Reference may also be made to an interesting article in the same issue on the origin of slavery among ants, by Dr. W. M. Wheeler.

THE training of foresters for India and the organisation of the scientific work of the department form the subject of a leading article in the *Indian Forester* (September), in which the writer points out the necessity for a systematised programme arranging for the compilation of forestry data and research. An article on improvement fellings is concerned with the problem of increasing the growing stock of teak. Premising that many saplings are killed by creepers and faster growing trees, the author, Mr. H. C. Walker, adduces arguments and statistics in favour of taking measures for saving young teak trees by a judicious system of thinning.

AMONG the experimental work referred to by Mr. W. Fawcett, director of the Public Gardens and Plantations, Jamaica, in his annual report for the year 1906-7, the raising of selected seedling sugar canes and the cultivation of Havana and Sumatra tobacco are of primary importance. It is recorded that as a result of comparative experiments a better yield of coffee has been obtained at the Hope Gardens under shade than without shade, and preference is given to the guango, *Pithecolobium saman*. The satisfactory results attending the instruction of small landholders by travelling instructors are noteworthy; by this means, as also by the establishment of agricultural banks and prize-holding schemes, the agricultural population is developing an appreciation for improved methods of cultivation.

MUCH valuable information on insect pests attacking crops is being disseminated by the Bureau of Entomology, forming part of the United States Department of Agriculture. In Bulletin No. 68, part iii., Mr. A. L. Quaintance deals with the trumpet leaf-miner of the apple, *Tischeria malifoliella*, a Tineid moth that is destructive to species of *Crataegus* and *Pyrus*. The mines are burrowed by the larvæ in the palisade layers of the leaf. Spraying with kerosene emulsion is recommended for destroying the larvæ and pupæ. Mr. A. A. Girault describes the life-history of the lesser peach-borer in Bulletin No. 68, part iv. The species, formerly referred to *Sesia*, a genus of moths of the family Sphingidae, now receives the name of *Synanthedon pictipes*. It occurs principally on plum and peach trees, and must be distinguished from the better-known peach-borer, *Saminoidea extisiosa*.

In his annual address to the Australasian Association for the Advancement of Science, Dr. A. W. Howitt gives an account of his reminiscences of Central Australian exploration, and in particular of the search for the ill-fated members of the Burke-Wills expedition. The causes of the failure of this enterprise lay, he shows, in the extravagant amount of supplies provided, for which carriage was inadequate, in the impetuosity of the leader, and in want of cooperation on the part of certain members of his staff.

THE second number of the Journal of the revived Gypsy Lore Society, with its headquarters at 6 Hope Place, Liverpool, contains a reprint, revised by the author, Mr. C. G. Leland, of an article on the remarkable dialect known as Shelta, spoken by wandering tinkers, and apparently of Celtic origin. This a preliminary to a

further study of this dialect. Mr. J. Sampson gives an interesting account of his experiences with a gang of German Gypsies at Blackpool. Mr. D. MacRitchie has collected much curious information to prove that throughout eastern Europe the Gypsies were formerly subjects of certain great noblemen, not of Gypsy race, who were appointed to that position by the rulers of those countries. Mr. W. M. Gallichan furnishes a report on the Gypsies of Andalusia, Mr. B. Gilliat-Smith on those of the Rhine Province, and Dr. T. R. Gyorjevic on those of Bosnia. A collection of interesting miscellaneous notes completes an excellent number, which has as its frontispiece a portrait of that eminent Gypsy scholar, Dr. A. G. Paspati.

THE *Reliquary*, under the editorship of Dr. J. C. Cox, in succession to the late Mr. J. Romilly Allen, continues to be one of the most scholarly of our archaeological publications. In the last quarterly number, issued in October, one of the most interesting articles is that by Mr. G. Le Blanc Smith on some dragonesque forms on, and beneath, fonts. Numerous examples of such a form of decoration are found in Sweden, but some in this country are equally interesting. One favourite type is that of the salamander, which is always represented as a lizard with bifurcated tail, in which there is one coil or twist. It has two legs set very far back on its body, a rather humped back covered by a pair of wings, longish ears, and a dragon-like head. In many cases the body of the animal is covered with scales, and the wings are clothed with feathers. The toes or claws are invariably three in number. Its countenance bears a look of loathing or disappointment, the symbol of its defeat as representing the powers of evil by the baptismal rite. The best examples of such figures are found on fonts at Norton and Youlgreave, both in Derbyshire. The second type represents dragons or grotesque monsters, humbled and abased, grovelling under the font itself, of which they form the base. Such are the fonts at Hereford Cathedral and at Castle Froome, in Herefordshire. A curious development is that at Ashford, where the animal is carved as though it actually protruded through the shaft of the font—the head at one side, the curly tail at the other. Mr. Le Blanc Smith asks for aid in discovering similar representations of monsters in other parts of the country.

A PAPER on the predetermination of train-resistance was read by Mr. C. A. Carus-Wilson before the Institution of Civil Engineers on December 10. Among the practical conclusions arrived at are that the resistance of the air with a train of bogie-coaches, running at sixty miles per hour, amounts to about one-half the total tractive effort required to haul the train. Experiments conducted by the St. Louis Electric Railway Test Commission show that a large reduction can be made in the front and rear air-resistance by shaping the ends, and that by this means a saving can be effected of 10 per cent. of the total tractive effort with a long passenger train, and 30 per cent. with a single coach.

A COLONIAL OFFICE report (Cd. 3794) has been issued giving Major E. H. Hill's report on the Survey Department of British East Africa. The work at present in progress is the main triangulation of the country. Major Hill says that an additional section of two officers and six or eight surveyors is imperative to prepare topographic maps before the trigonometrical beacons are destroyed. He recommends that topographic maps should be issued on the scale of 1 to 125,000. He discusses a proposal for a school to train African natives for the survey work; but

he regards the natives of British East Africa as at present quite useless for this purpose, while those trained on the west coast could not be employed in the highlands of East Africa. Indian natives are being employed, but have not proved altogether satisfactory.

REVIEWING the world's tin-mining industry, Mr. A. Selwyn-Brown, in the *Engineering Magazine* (vol. xxxiv., No. 2), shows that the world's production of tin last year was 96,196 tons. The active tin-mining fields are few in number, and, as a rule, not in a very prosperous condition, notwithstanding the high value of tin and the large existing demand for it. The alluvial deposits in the Dutch East Indies and in the Malay States are approaching exhaustion, and difficulties are being caused by the scarcity of coolie labour. Bolivia is advancing its consumption, but it is upon Australia and Tasmania that consumers will have to depend for the principal part of their tin supplies, unless Africa should develop into a tin-mining country of importance.

A STRONG gale traversed Scotland and the north-east of England during Friday night and Saturday in last week. During its progress over our island the cyclonic system increased greatly in depth, the lowest reading of the barometer reported being 28.39 inches, at Spurn Head, at 8 a.m. on Saturday. The greatest strength of the wind was from the north-west, and was due to a sharp rise of the barometer in the rear of the disturbance. The heaviest part of the storm occurred over the southern portion of the kingdom, where considerable damage was occasioned, and wrecks, accompanied with loss of life, occurred in the English Channel. Heavy rain preceded the storm, and large tracts of land were flooded in the Midlands and in the southern districts. A fall of temperature was experienced after the passage of the storm area, and frost has occurred in several places.

In a lecture delivered before the meeting of German Naturalists and Physicians at Dresden in September last, Dr. E. Herrmann directed attention to his researches on the periodical variations of atmospheric pressure, and to the possibility of submitting the phenomena to numerical investigation. For this purpose he used the well-known daily synoptic weather charts of the North Atlantic Ocean and adjacent continents issued by the Deutsche Seewarte and the Danish Meteorological Institute. The diagrams which accompany his paper, a copy of which he has sent to us, seem to show that a succession of analogous phenomena occurs at regular intervals, and that areas of low and high barometric pressure follow each other at certain distances. He asserts that the periods exhibited are due to the moon's movements or to a combination of these with that of the sun. We remember that Sir J. Herschel stated that the moon's influence is "utterly insignificant as a meteorological cause." Nevertheless, Dr. Herrmann's paper may be considered as a painstaking endeavour to throw light upon the intricate processes involved in the general atmospheric circulation.

MR. GUSTAV FISCHER, of Jena, has just published the second edition of Prof. L. Jost's "Vorlesungen über Pflanzen-physiologie," the first edition of which was very favourably reviewed in *NATURE* of July 14, 1904 (vol. lxx., p. 242). The work has been translated into English, and a review of this edition appeared in *NATURE* of December 5 (p. 97).

A THIRD edition of "Practical Forestry and its Bearing on the Improvement of Estates," by Prof. Charles E. Curtis, has been published by Messrs. Crosby Lockwood

and Son. The work has been revised and also enlarged by the addition of an appendix on the planting of waste lands, a project which the author hopes may not only add to the wealth of the nation, but give employment to the rural population, and so keep them upon the land. It is pointed out in the volume that the management of our woodlands is improving, and that what was once a source of loss is becoming a source of profit.

THE twenty-third issue of "Hazzell's Annual," that for 1908, is even more complete than previous editions. It is an alphabetically arranged, cyclopædic record of men and affairs designed especially to be of use in 1908. Articles are provided, for example, on the Olympic games, the Franco-British Exhibition, and on recent work in colour photography. The most important of the Blue-books published during 1907 are summarised, and among these abridgments likely to be of special assistance to readers of *NATURE* may be mentioned those dealing with agriculture, education, and sea fisheries. The busy worker in many departments of knowledge will find the annual a trustworthy and useful work of reference.

THOUGH it has not increased in price, "Who's Who" continues to grow in size. Messrs. A. and C. Black, the publishers of this work of reference, which may justly be described as indispensable, have this year added eighty-three pages of biographies, and the new volume contains 2040 pages. The biographical notices vary much in length, and, unfortunately, the longest notices are not always those of the most important persons; but, despite such inequalities, the book may be unreservedly recommended to those readers whose necessity it is to know something about the men and women who, for one cause or another, have become prominent in work or play. "Who's Who Year-book, 1908," is also larger than its predecessors, and its clearly arranged and exhaustive tabular matter will continue to be consulted by everybody desiring a minimum of trouble in the task of reference.

THE Rev. Robert Harley, F.R.S., has written an interesting biographical sketch of Robert Rawson, who achieved some distinction in the scientific world by his work in mathematics and on the dynamical stability of floating bodies. Rawson was originally a Midland miner whose mathematical ability attracted the notice of Stephenson and Prof. Eaton Hodgkinson. He became a teacher of mathematics at Manchester, and contributed several papers to the Literary and Philosophical Society of that city. In 1847 he was appointed the first headmaster of H.M. Dockyard School, Portsmouth, upon the recommendation of Prof. Hodgkinson, and he occupied this post for twenty-eight years, among the men who passed through the school during this period being Sir Philip Watts, K.C.B., F.R.S., Sir John Durston, K.C.B., and Dr. Francis Elgar, F.R.S. Rawson died in March, 1906, and was buried in Havant cemetery. Mr. Harley's appreciative account of his career is published by Messrs. J. Clarke and Co., 13 and 14 Fleet Street, E.C., and Messrs. Griffin and Co., Portsea.

In the "Day by Day" Tellurian which Messrs. G. Philip and Son have submitted to us, a simple and novel means is used to preserve the constant direction of the terrestrial axis in the course of the revolution of the earth around the sun. The tellurian is intended to be suspended on a wall or some other convenient vertical plane. The sun and earth are represented by two globes connected by a rod upon a diagram showing the months and other divisions of the year. As the terrestrial globe is moved around the globe representing the sun, a heavy bob attached by thick wire to the axis is maintained vertical by the

attraction of gravity, and this constant direction enables the axis to be kept inclined at the same angle to the plane of the diagram throughout a revolution. The result is that the terrestrial globe only rotates on its axis once during a complete revolution. This is misleading, and it will be necessary for the teacher to explain that though the device illustrates the different aspects of the earth presented to the sun during the year on account of the constant inclination of the axis, it does not represent accurately the relation between the day and the year. With this reservation, the model may be found of service in teaching astronomical geography.

MESSRS. TAYLOR AND FRANCIS have now published the first part of the fourth volume on Rhynchota, by Mr. W. L. Distant, of "The Fauna of British India, including Ceylon and Burma." These volumes are published under the authority of the Secretary of State for India in Council, and edited by Lieut.-Colonel C. T. Bingham. The third volume on Rhynchota was reviewed in NATURE of July 5, 1906 (vol. lxxiv., p. 221). The present fasciculus gives an account of the homopterous families Membracidae and Cercopidae, and four subfamilies of the Jassidae. The second part—in the appearance of which there is likely to be some delay owing to the necessity of examining material at present contained only in certain Continental museums—will contain the remaining subfamilies of the Jassidae and an appendix to the whole work.

MESSRS. J. AND A. CHURCHILL have published a tenth edition of Valentin's widely known "Practical Chemistry." Prof. W. R. Hodgkinson has added to the present issue easy experimental work in the early chapters, on the composition of air and water, some carbon compounds, sulphur and sulphuric acid, exercises on quantitative analysis, volumetric analyses, and methods of ascertaining molecular weight. The microscopic structure of some common alloys has been illustrated by photographs, and the whole work revised and brought up to date. The volume now runs to 476 pages, and its price is 10s. net.

OUR ASTRONOMICAL COLUMN.

THE MAXIMUM OF MIRA, 1906.—Mr. Naozo Ichinohe, of the Yerkes Observatory, observed Mira, for magnitude, from October 10, 1906, to March 8, 1907, and publishes his results, with a curve, in No. 4219 of the *Astronomische Nachrichten* (p. 311, December 5). These show that the maximum brightness occurred on December 12, 1906, which was about seven days before the predicted date. This early date is confirmed by the results of other observers, which give December 13, 12, and 7 respectively.

A FURTHER OBSERVATION OF COMET 1907A.—A telegram to the Kiel Centralstelle from Prof. Wolf states that comet 1907a was re-observed at the Königstuhl Observatory on December 4. At 11h. 33m. on that date its position was $\alpha=3h. 23m. 40s.$, $\delta=+50^{\circ} 35'$, a little to the north-east of α Persei, and its magnitude was 12.5. The motion of the object was found to be in accordance with the ephemeris (*Astronomische Nachrichten*, No. 4219, p. 315, December 5).

SPECTROSCOPIC DETERMINATION OF THE ROTATION OF THE SUN.—In a paper published in No. 4, vol. xxvi., of the *Astrophysical Journal* (p. 203, November), Prof. Adams describes at some length the instruments and methods employed by him at the Solar Observatory, Mount Wilson, in a spectroscopic determination of solar rotation period, and, after discussing them, he compares his results with those obtained previously by Dunér and Halm.

In the lower latitudes of the solar disc the recent results agree very well with the values obtained by Dunér and Halm, but in higher latitudes they lie between those of the previous observers. The rate of change of the velocity with the latitude attains a maximum in latitude 30° , be-

coming less in higher latitudes, and almost disappearing beyond 70° . Twenty lines, lying between λ 4190 and λ 4300, and attributed to different elements, were employed in the research, and it was found that different lines gave different rotational velocities. The titanium line at λ 4290.38 gave a systematically low value, although it is an enhanced line, and might therefore be expected to have its origin in the higher levels of the solar atmosphere. Two lines of manganese, λ 4257.82 and λ 4266.08, gave a consistently high value. Two carbon lines and a line due to lanthanum give low values, thus agreeing with the conclusion that these two elements reside in the lower layers of the sun's atmosphere. There are no indications of a variable velocity for any one latitude during the fourteen months of observation (May, 1906, to June, 1907), and the results appear to show that the photographic method displays a considerable gain of accuracy over the visual method so far as accidental errors of measurement are concerned.

NEWLY DISCOVERED SPECTROSCOPIC BINARIES.—Bulletin No. 123 of the Lick Observatory announces the recent discovery of the variable radial velocities of ten stars. Two of these, α Carinae and γ Gruis, were found to be binaries on examining plates taken at Santiago; the other eight were discovered at Mount Hamilton. They are α , β , and δ Tauri, γ Camelopardalis, α Boötis, β Coronae, ξ Cygni, and ζ Cephei.

In the same Bulletin Mr. A. B. Turner publishes a set of elements, and a velocity curve, for the spectroscopic binary ω Draconis, showing the period to be 5.27668 days and the length of the semi-major axis of the orbit to be 2,632,300 km. The velocity of the system is -13.68 km., and the orbit appears to be nearly circular, its eccentricity being only 0.0107.

THE ASTROGRAPHIC CATALOGUE.—We have received from the Catania Observatory the first part of their contribution to the International Astrographic Catalogue. Catania undertook the region dec. $+46^{\circ}$ to dec. $+55^{\circ}$, and the present volume contains the results for the region dec. $+50^{\circ}$ to $+52^{\circ}$, R.A. oh. to 3h. In an introduction Prof. Riccò, the director of the observatory, describes the instruments employed—photographs of the astrographic equatorial and the micrometer appear as a frontispiece—and discusses the methods followed in the reduction of the plates. The positions (1900) of some 7000 stars are included in the present work.

STARS HAVING PECULIAR SPECTRA.—From the examination of Henry Draper memorial photographs, Mrs. Fleming has discovered a number of variable stars and other objects having peculiar spectra, particulars of which are given in Circular No. 132 of the Harvard College Observatory. The Harvard plates show that D.M. $+66^{\circ}.780$, given by Dunér and by Krüger as a fourth-type star, gives a spectrum at times which contains no bright lines, whilst at other times the spectrum contains H β bright; the intensity of the spectrum also varies in certain regions.

WEAKENED LINES IN SUN-SPOT SPECTRA.—In No. 3, vol. xxvi., of the *Astrophysical Journal*, Mr. Nagaraja, of the Kodaikanal Observatory, gives the wave-lengths of, and discusses, 167 lines which he has found to become weakened in passing from the spectrum of the photosphere to that of sun-spots. The photographs from which Mr. Nagaraja obtained his data were taken with a Rowland grating camera fitted up by Mr. Evershed, and include the region F-D. Considering the forty or so lines due to iron, titanium, and chromium given in this region as enhanced lines by Sir Norman Lockyer, and four more recently announced by Prof. Fowler, Mr. Nagaraja finds that the majority of them are weakened in spots.

Two enhanced lines of iron at λ 5169.07 and λ 5169.22, one enhanced titanium line (λ 5188.87), and two enhanced lines of chromium ($\lambda\lambda$ 5502.9 and 5621.7) appear to be exceptions, however. With one exception (λ 5284.281, Ti), all the titanium and chromium lines weakened in spots are of the enhanced type. A comparison of the chromospheric and spot-weakened lines shows that only a fraction of the former are weakened in spots, and that a large number of the weakened lines belong to the higher levels of the chromosphere.

EXHIBITION OF PHYSICAL APPARATUS.

THE third annual exhibition of physical apparatus, held under the auspices of the Physical Society of London at the Royal College of Science on December 13, was an unqualified success. Notwithstanding the inclemency of the weather there was a good attendance, many members of the society coming up from distant towns in order to take advantage of the opportunity of inspecting the apparatus itself in lieu of looking through the catalogues of so many makers. Printed and verbal information was available in abundance, and in connection with the former it may not be out of place to offer a word of advice to makers. Any catalogue, however carefully compiled, is in the case of a progressive maker out of date a few months after publication, and is generally supplemented by separate sheets sent out to customers. Very few makers have these sheets cut the same size as their catalogues, and fewer still provide clips at the ends of their catalogues by means of which the additional sheets, sent out punched in the left-hand margin, can be permanently incorporated in the catalogue. They lie about on desks instead until they look dusty and disreputable, and are then consigned to the waste-paper basket, and the information contained in them is forgotten.

As one would naturally expect, the exhibition was strongest on the electrical side, but other branches were not neglected. In general physics, the silica ware exhibited by Messrs. J. J. Griffin and Sons attracted a considerable amount of attention. Bowls of 6 inches diameter, boiling flasks of 3 inches, and tubes of all kinds can now be made of transparent silica, while much larger objects are made of the opaque variety.

Messrs. C. F. Casella and Co. exhibited a telemeter with an 8-foot base, arranged to measure both distances and differences of level, the telescopes rotating about the base and the base about a vertical axis through its centre to eliminate errors. They showed also a direct-reading anemometer on which the revolutions are given by an ordinary engine counter. Messrs. Elliott Bros. exhibited their new "motometer," or speed indicator, for motor-cars, which is driven from a flat rubber ring attached to the front off-side wheel of the car by means of a friction wheel and flexible shaft.

In heat, the most interesting exhibit was that of the Meteorological Office, which consisted of balloon and kite meteorographs and traces obtained by means of them. Mr. Dines's instrument for recording pressure and temperature on a square inch of thin copper weighs one ounce only, and is most ingenious. Records of ascents of 18 to 20 kilometres, made at the same time at four stations in this country, showed a fair agreement in the temperatures at the same heights over the four stations at comparatively low levels, but considerable differences at high levels.

In photometry there appeared to be a general adoption of the flicker photometer and of the inclined screen method of varying the effect of one of the sources. The movement of the screen is effected by means of a cam rotated by a milled head outside the photometer box, to which a pointer reading on a scale marked directly in candle-power is attached. The uniformity of the divisions is secured by the shape of the cam.

Messrs. A. Hilger, Ltd., exhibited a large spectroscopic telescope of which was moved by a tangent screw graduated on the head directly in wave-lengths. They also had on view a Fabry and Perot interferometer with the interference bands visible, so that the displacement produced by separating the plates could be observed.

Two new photographic lenses giving very flat fields were exhibited, the "Isostigmatic" by Messrs. R. and J. Beck, and the "Homocentric" by Messrs. Ross, Ltd.

The work on radio-activity, which is being carried on so vigorously, has raised the electroscopie to a position undreamed of a dozen years ago, and amongst the many new forms it now takes may be mentioned one constructed by Mr. C. W. Cook, of Manchester, for Prof. Rutherford, and exhibited by Messrs. J. J. Griffin. It contains a compartment below the leaves in which the radio-active material to be investigated can be placed.

Resistance bridges for the most accurate work appear to be tending towards the enclosed type, with oil circulation

to ensure uniformity of temperature. The Cambridge Scientific Instrument Co. showed a Callendar and Griffiths bridge in which plug contacts were replaced by mercury, also enclosed, to prevent the mercury getting to the brass-work.

Several makers seem to be alive to the possibilities of the flat form of resistance coil owing to its compactness and freedom from inductance and capacity. Mr. L. Miller's machine for winding the wire of induction coils in flat vertical sections, the wire passing from outside to inside and back again without a break throughout the whole length of the coil, seems to make it possible to build larger coils without insulation troubles arising. His mica-disc valve, which interposes a disc of mica in a short air gap in the secondary circuit of the coil during the make, and so cuts down the make current that the secondary current is practically unidirectional, should prove a great aid in vacuum-tube work.

Moving magnet galvanometers show a tendency to take the Broca form, in which astaticism is secured by making the poles between the coils consequent poles at the centres of two magnets placed vertically. Instruments so constructed were shown by the Cambridge Scientific Instrument Co. and by Messrs. Clark Fisher and Wadsworth. A very useful addition to the moving coil type of galvanometer was exhibited by Messrs. Gambrell Bros. It consists of a resistance within the galvanometer case, which when placed across the terminals of the instrument renders it aperiodic. One end of it is connected to one terminal of the instrument, and the other to a third terminal, so that it may also be used to diminish the sensitiveness of the galvanometer.

Messrs. Paul exhibited a Campbell vibration galvanometer, which is a moving coil instrument of very short period, the control being of the bifilar type, and the amplitude of the oscillations being observed in working with the instrument. Other instruments for small alternating currents were Duddell's thermo-ammeter, on the same principle as his thermo-galvanometer, shown by the Cambridge Scientific Instrument Co., and Cohen's barretter, shown by Mr. R. W. Paul. This instrument is of the bolometer type, the filaments the resistances of which are changed by the current to be measured being those of the 24-volt lamps used on telephone switchboards.

Of instruments intended for commercial work, the iron-clad indicating wattmeter shown by Messrs. Nalder and Thompson may be mentioned, as it illustrates the present tendency to secure larger torques by placing the moving coil in the field of a laminated series or shunt electromagnet.

Messrs. Nalder Bros. exhibited a compact testing set weighing only 14 lb., capable of measuring insulations up to 2000 megohms with 100 volts, and Messrs. Evershed and Vignoles several of their "meggers" of various ranges up to 1000 megohms.

The Physical Society is to be congratulated on the success of its exhibition, and the various exhibitors on the interest which their display evoked. C. H. L.

ON THE INCIDENCE OF DAYLIGHT AS A DETERMINING FACTOR IN BIRD-MIGRATION.¹

THE existence of the phenomenon of bird migration is only explicable, like that of all other phenomena of life in both animal and vegetable kingdoms, by the theory of natural selection. It has proved beneficial to certain families of birds in the struggle for existence to wander at certain times of the year in particular directions, and to greater or less distances, such wanderings having led them to regions which were more suitable than others for feeding or breeding. On this general question there can be no difference of opinion at the present day.

But if we leave the general problem and come to deal with specific parts of it, such as the nature of the directing force in migration, or why for certain birds northern latitudes are more suitable as breeding quarters than southern, why for others eastern longitudes than western, we at once enter upon questions regarding which there is

¹ Address to the Scottish Natural History Society, November 7, by Prof. E. A. Schäfer, F.R.S.

great divergence of opinion, and as to which scarcely any two naturalists who have studied the subject are in complete agreement.

The part of the problem that I propose here to consider can be thus stated:—Is there any physiological reason to account for the fact that for that class of birds which we may call the north-south migrants northern latitudes have determined themselves as the most suitable for summer quarters and breeding grounds, and southern latitudes for winter quarters?¹

The physiological reason for this choice of quarters which most naturally suggests itself concerns the presence or absence of food, or its relative abundance and the means of procuring it. From the Arctic circle, where during winter the whole of nature, sea and land alike, is in the grip of an intensity of cold of which we can form little conception, and which few animals can withstand, birds, at any rate, must move southward, or they would inevitably perish of cold and starvation. It thus appears easy to account for one aspect of the north-south migration problem by referring it to the necessity of avoiding destruction by starvation; but even for this aspect of the question the answer is not quite so simple as at first sight appears. For it fails to account for the distances which such migrations often take, since a passage into the north temperate region alone would suffice to obviate this difficulty; yet this region is, for the most part, passed in the migration of many Arctic birds, which may not stop until a tropical or even a southern hemisphere region is attained; and not only so, but the north-south migrants of the north temperate zone themselves share in the migration, passing away for the winter to a southerly clime. Many of these cannot be said to be driven south by the lack of food, for at the time the migration occurs food is usually still abundant, and there is plenty of food during the whole winter in many of the countries which are passed to support, not only the permanent avine inhabitants, but in some regions myriads of east-west migrants besides.

Moreover, there is evidence that during the Tertiary period the climate of the Arctic circle was entirely different from that which now exists—warm and mild, and abounding with vegetable and animal life—and there was then no necessity for north-south migration on the score of want of food materials. Yet it is impossible not to suppose that that migrations occurred then as now, since the habit of migration is so ineradicably engrained in the nature of the bird that it is difficult to believe that it was not evolved along with the development of the organs of flight.

If we now turn to the other aspect of the north-south migration problem and consider the causation of the movement from south to north, we see that the explanation *re* food supply, which seems easy to formulate for the north to south movement, at once breaks down, for the tropical and temperate regions are at any rate not less abundantly provided with food during summer than the regions of the far north to which the majority of these migrants wend their way. The difficulty is a serious one. The explanation which was used to account for the north to south movement is not available for the opposite movement; some other explanation must be found. Here the weakness of the original explanation manifests itself, for it would be natural to suppose that the reversal of an effect would be the result of the reversal of the cause which produced the effect, and this is not the case in the present instance.

What, then, are alleged to be the reasons for the south to north migration in the spring? One of these supposed reasons is both given and at the same time refuted by Gätke ("Birds of Heligoland," English translation, p. 144) in the following passage:—"From very old times, mainly in consequence of the phenomena which succeeded migration, it was conceived that in spring, with re-awakening life in Nature generally, the reproductive instinct of birds—also was roused afresh, and that it was this which urged them to wander to their nesting places; while in autumn, dearth of food and cold admonished them to make a temporary home in warmer latitudes. This view has, in part, held its ground up to recent times, for it is not so long ago that Brehm, in one of his talented discourses

on this inexhaustible theme, maintained that the two great factors in the world's action, *Hunger and Love*, also dominated the migratory movements of birds. . . . These explanations, however, do not suffice . . . it cannot be the reproductive instinct which prompts birds to set out on their spring migration, for many species do not breed in the first, second, or even third year of their life, and yet migrate to their homes just like those of their congeners who are endowed with the capacity of breeding; nor are they induced to travel by the example of their parents, for they start on their journey alone, and independently."¹ Gätke concludes as follows:—"In regard to this question as to the immediate cause of the departure of birds in their migration . . . we are confronted with a riddle which has hitherto defied every attempt at a solution, and which indeed we may hardly expect will ever be likely to receive a final explanation."²

We may take it, then, that the hypothesis that the commencing recrudescence of the generative functions in spring is the determining agent for the migration from south to north does not furnish an adequate explanation of the phenomenon, even if it were certain, as is by no means the case, that such recrudescence begins before the commencement of the movement. It seems obvious that there must be something in the higher latitudes which is favourable to breeding or to the rearing of offspring. Are we to suppose this favourable factor to be relative coldness? *Prima facie* this seems improbable. Other animals, including non-migrating tropical birds, breed freely in the hottest regions of the earth's surface, and warmth is favourable for incubation. Many of the east-west migrants have their breeding grounds in the interior of the great Asia-European continent, which is in the summer much warmer than its western shores. I have been unable to come across any fact which would lead me to suppose that mere diminution of temperature assists breeding. There are, it is true, some fishes and possibly a few other animals that produce their eggs and young in the winter, but in by far the majority it is the warmer season of the year which is occupied with the propagation of the race. We are therefore forced to conclude that the south to north migration is not brought about because of the necessity or advantage of a colder climate for breeding and nesting. Is there, then, any other means of explaining why it is advantageous for certain birds to pass the summer, and especially to breed, in high latitudes, which will equally account for the fact that lower latitudes present corresponding advantages during the winter season? It is an answer to this question that I will now attempt to give.

Let us begin by admitting that bird-migration must have been brought about by the necessity for procuring a sufficient supply of food. The importance of this at all periods is self-evident, but it becomes accentuated in the breeding season, when not only the needs of the parent birds, but also those of their voracious offspring, have to be met. It appears to have been assumed by most writers that for the north-south migrants the higher latitude or summer region of distribution, to which they resort for the breeding season, represents their original home or habitat; to which it is only natural they should desire to return when the desire for breeding comes upon them, and that the migration to lower latitudes is brought about by climatic conditions, such as frost and cold, which render the procuring of food a matter of difficulty or impossibility during winter. There are, however, as has already been pointed out, difficulties in accepting the climatic conditions and accompanying deprivation of food supply as affording the only or even the chief explanation of migration, and more especially of the acquisition by birds of the north-south migratory habit. Thus it fails, as we have seen, to explain the south to north migration in the spring, and would be an inadequate reason for much of the autumnal migration which occurs from the northern temperate zone, such as that of those migratory marine birds the food of which is abundant in the northern seas throughout the winter. It at first sight appears also to fail to account for the fact that with many species of birds autumnal migration occurs before the advent of severe weather; and at a time when the food supply in the higher latitude is as abundant as ever, and that their

¹ For convenience of description the migrants are here assumed to belong to the northern hemisphere.

return from lower latitudes often takes place when the food supply there is more abundant than in the higher latitude to which they are travelling, and may even remain abundant. But although a deficiency of food could not in such circumstances be the immediate determining cause of the movement, an approaching deficiency might, nevertheless, be the ultimate cause, for the most appropriate time for leaving a region which is to become uninhabitable would be determined for each species by natural selection, and might thus appear to have no immediate connection with deficiency of the food supply, although in reality dependent upon it.

It is known, however, that, as has already been stated, during the whole Tertiary period there was a mild or warm climate and abundant vegetation throughout what are now the Arctic and sub-Arctic regions, and it was under these conditions, which presuppose abundance of food supply during the whole winter, even in the highest latitudes, that many existing genera of birds were evolved. We may take it, therefore, that at that period the autumnal migration was not rendered necessary by the approaching severity of the winter months.

This being the case, the question has suggested itself whether the relation of daylight to darkness may not have furnished the factor of most importance in the determination of both the south to north and north to south movements, in consequence of the necessity to most birds of daylight for the procuring of food.

In no other class of vertebrate animals is the sense of sight more important than in birds, and in no other is it so highly developed. For detecting and obtaining food most birds depend entirely upon vision, with perhaps, in some, assistance from audition, and, in the case of soft-billed birds, from palpation, but with little or no aid from the olfactory sense, which is in so many animals the most important of the senses in this connection. But vision is not possible in the total absence of light, nor, without special retinal adaptation, in semi-darkness. Hence the great majority of birds—diurnal birds—are dependent upon daylight for the procuring of food; relatively few, such as most owls and nightjars (crepuscular and nocturnal birds), are able to obtain food only in semi-darkness (twilight, moonlight, or starlight); a certain number, e.g. many waders, appear to possess retinal adaptation both for ordinary light and for light of low intensity; but, so far as I am aware, no birds, except those which are provided with tactile bills, are able to seek food in total darkness.

From this consideration it is obvious that the proportion of the twenty-four-hour cycle which can be utilised by birds for obtaining food becomes greatly diminished during the winter months in high latitudes, and may be reduced to *nil* within the Arctic circle, while during the summer months the amount of daylight in high latitudes is proportionately increased. Many birds are voracious feeders, and during the hours of daylight are almost constantly engaged in the search for food. It is therefore a necessity that the time during which alone they can see to engage in the search shall not be unduly restricted, as would be the case in high latitudes during the winter, even in parts which are rarely or never frost-bound. This the north to south or autumnal migration provides against. During the breeding season, when the young birds also have to be fed, it is important that the time which can be occupied in the search for food should be prolonged, and this is provided by the south to north migration in the spring. Everyone who has lived in northern latitudes must have been struck with the time occupied by many birds during the long summer days in procuring food for themselves and their young; in fact, no more striking object-lesson of the utility of prolonged daylight for the rearing of their offspring can well be afforded.

The objection might be taken to the relative incidence of daylight and darkness at different seasons being regarded as a factor in causing north-south migration, that in the case of nocturnal birds the course of migration ought to be the other way, viz. from south to north in autumn and from north to south in spring (in the northern hemisphere); but, as has been already pointed out, the so-called nocturnal birds are not, as is popularly supposed, birds which can see in the dark, but birds the vision of which is adapted permanently for light of low intensity,

such as twilight. Migration with such birds occurs in the same sense as with diurnal birds, i.e. north to south in autumn and south to north in spring (in the northern hemisphere). This is, in fact, what might have been anticipated, seeing how greatly the summer twilights are prolonged in high latitudes.

Again, it might be objected that the circumstance of many birds leaving the higher or lower latitudes before the autumnal or vernal equinox militates against the assumption that the autumnal migration is determined by a relative deficiency of light in higher latitudes during the winter months, and that the vernal migration is determined by the longer daylight which obtains in those latitudes during the summer months. This objection is, however, obviously met in the same manner as with the analogous objection raised to the "food-supply" theory pure and simple, viz. that the most appropriate time for the actual commencement of migration will have been determined for each species by the process of natural selection.

Further, the assumption that the relation of light to darkness rather than severity of climatic conditions has been the determining factor in producing the north-south migrations would better explain the singular constancy in the times of year at which these migrations occur. For not only are the times of migration in many cases independent of the actual climatic conditions which are supposed to be the determining cause of the movement, but the climatic conditions themselves vary considerably from year to year in their inception and progress. On the other hand, the incidence of the proportion of light to darkness is a constant factor, and might even be conceived to be operative in exciting the migratory instinct into activity in the same manner as it is here assumed to have been the original determining cause of north-south migration. That there are other stimuli seems probable from the circumstance that some birds have their winter quarters in the equatorial region, where the proportion of day to night does not vary throughout the year. There are, however, very regular seasonal changes in that region, which are accompanied by marked differences in amount of daylight, and for those migrants which winter there these seasonal changes may serve as the initiating stimulus to northerly migration. That it is a result of developmental changes in the sexual organs is improbable, since sexually immature individuals are also subject to the migratory tendency; nor is there any evidence that such changes begin prior to migration. In any case, the regularity with which migration occurs indicates that the exciting cause must be regular. There is no yearly change, outside the equatorial zone, that occurs so regularly in point of time as the change in the duration of daylight. On this ground this may well be considered a possible determining factor in migration, and it has the advantage over other suggested factors that it applies to the northerly as well as to the southerly movement.

Besides the north-south migrations with which we are more immediately concerned, there are also the great east-west vernal and autumnal movements which are so prominent a feature in the eastern parts of these islands, and also migrations of a more local character, both of which merit some allusion in connection with the general question of migration.

As regards the east-west movements, which are, in fact, for many species a part of the general north-south migrations,¹ it has been supposed that these diversifications from the main north-south stream have become evolved either as the result of changes in the earth's surface, which have produced a modification of the general north-south trend,² or that they are the expression of the course of expansion of the breeding range of the species as it approaches its northern limit.³ The physiological reason for the east-west movement must ultimately be sought, as in the north-south movement, in facility for the obtaining of food, and it may fairly be assumed that in the case

¹ For the evidence of this see Gätke, "Heligoland an Ornithological Observatory," pp. 39-42. Also the British Association reports on bird migration, especially the "Digest," by W. Eagle Clarke, in report of Liverpool meeting, 1826.

² Evans, Cambridge Natural History, "Birds," p. 18.

³ Dixen, "The Migration of Birds," 1897, p. 35; also p. 40.

of species which show no north-south tendency in migration and which are confined to the temperate zones there is sufficient opportunity, even in shortened days, of obtaining such food as they require for subsistence in the region to which they have betaken themselves for winter quarters. Many of these east-west migrants are either graminivorous or live on insects and grubs which they seek in the ground or on trees. In the summer their food is most abundant in the great grain-producing or forest-clad central regions of the Asia-European continent, while in the winter they are compelled to seek their subsistence in a less severe climate.

Another kind of migration is that which may be produced by local conditions of food and pressure of bird population. If in any particular zone food of appropriate character is obtainable at all times of the year in sufficient abundance, the necessity of migration to a higher or lower latitude is no longer necessary for a specific number of individuals, and their migration, and that of their descendants, will accordingly tend to limit itself to that zone, within which such migration as does occur will be more or less local.

Newton¹ suggested that the arrival of a large batch of migrants in a particular area or zone which is already occupied by birds of the same species may compel the individuals of that species which are in possession to move on in any direction where food is readily obtainable. It is perhaps more probable that later migrants into a zone already occupied by birds of the same species or habits may, on finding others already in possession, themselves push on into other regions. In this case the later migrants of species which vary in the extent of their migration would tend also to become the more extensive migrants, and would by natural selection transmit this tendency to their descendants. This conforms to the statement that those individuals of a species which migrate to the higher latitudes in the range of distribution of the species start their spring migration later than the individuals which migrate to less high latitudes.²

The theory that bird migration in the Holarctic area was originally determined by the encroachment and subsequent retreat of the ice-sheet over the temperate zone during the Glacial epoch (or epochs) is one which appears impossible to accept. Such a theory in its bare form involves the assumption that the habit of migration which so extensively pervades the avine class of vertebrates has been acquired during comparatively recent geological times, for which there is neither evidence nor probability. When we consider how extensively diffused is the tendency to migration of some kind amongst birds, it appears reasonable to assume that the habit was acquired at a comparatively early period of their evolutionary history. It may even be that the advantage gained by a more and more extensive movement of the kind was the predetermining cause, in the hands of natural selection, of the complete evolution of the avine type of vertebrate.

I have been able to find in the literature only two references dealing directly with the subject of the influence of light on bird migration. Seebohm ("The Geographical Distribution of the Family Charadriidae," London, 1888, p. 34) writes as follows:—"The first migrations of the ancestors of the Charadriidae were probably not in search of warmth, for the climate of the Polar Basin was in those remote ages mild enough; nor in search of food, which was probably abundant all the year round; but in search of light during the two or three months when the sun never rose above the horizon. The habit of migration thus formed became deeply rooted in the species, in accordance with the law of heredity; and doubtless acquired additional force when the terrors of a glacial epoch exterminated the conservative party amongst the Charadriidae (if any of them were foolish enough to neglect to adapt themselves to the changed circumstances), and compelled the survivors to extend their migrations far

and wide, until the shores of nearly all the rest of the world were visited on passage, or included in the winter range of some species of the family."

Seebohm evidently realised that, however warm the circumpolar area and however well stocked with food, it would be impossible for birds to subsist there all the year round on account of the absence of daylight during the winter months. It is the more strange that he should have failed to perceive the obvious corollary that these birds might seek such high latitudes during the summer months in the breeding season on account of the advantage offered for the procuring of food by the prolonged daylight.

Some fourteen years prior to the publication of Seebohm's work there appeared in the *Academy* (1874, vol. vi., p. 262), under the head of "Notes and News," the following paragraph, which, however, bears no indication of the source whence the information it contains was derived:—

"The aged poet Runeberg, the greatest scald that Sweden has ever had, has been in extremely weak health for many years past. It appears that as he has lain on his sick bed, at Helsingfors in Finland, he has occupied himself by close observation of the habits of birds, and specially with regard to the causes of migration, and he has at last put forward a singularly beautiful theory on the latter point. He believes, in fact, that it is the longing after light, and that alone, that draws the birds southwards. When the days shorten in the north, the birds go south, but as soon as ever the long northern nights (sic) set in, with all their luminous and long-drawn hours, the wanderers return to their old haunts. It is generally supposed that they move southward to get more abundant food; but why, asks Runeberg, do they leave their rich hunting-grounds to return to the north? The central regions of Europe are in every way more desirable than the wastes of Scandinavia. Only one thing is richer there, and that is light. The same instinct that makes plants firmly rooted in the ground strain towards the light, spreading upwards in search of it, works in the birds, who, on their free wings, fly after and follow it. This very suggestive and poetical notion is further carried out by reference to various analogies in natural history, and the final sentence is quite epigrammatic: 'The bird of passage is of noble birth; he bears a motto, and his motto is *Lux mea dux*.'"

The idea which is given voice to in the above paragraph bears a certain resemblance to that which I have endeavoured to set forth in this paper, but on close consideration it will be seen that the resemblance is purely superficial. What I have tried to urge is, not that these north-south migrants seek light *quâ* light, but that the sense by which alone they are for the most part able to obtain food necessitates their passage to regions where at one or another time of year there will be sufficient daylight to procure it. This is a special part of the general problem of food supply, itself an all-important agency in natural selection, which last there can be no doubt has been instrumental in determining the habit of migration. The theory attributed to Runeberg, in so far as it seeks to explain north-south migration by the endeavour of the bird to follow light alone without reference to the ultimate reason for such movement, in no way explains why birds rather than other animals should require light, and may well have merited the criticism to which it was at the time subjected by Prof. Newton (*NATURE*, September 24, 1874, p. 415), who pointed out that since "the southern movement not only begins but is with many species in great part accomplished long before the autumnal equinox, when consequently the birds are journeying to increasingly shorter days; and in like manner their northward movement is set on foot before the vernal equinox," the theory (that it is light alone that is the attraction) "contains its own refutation."

The object of this paper has been to endeavour to give a reasonable explanation of the north-south tendency, which is the most prominent feature of bird-migration. No attempt is made to explain all phenomena of migration. Obviously there are some migrations which cannot be explained on the assumption that the object of move-

¹ The paragraph was copied in the *Times* for September 18, 1874.

¹ "Dictionary of Birds," art. Migration.

² This appears to be the case with the swallow (see W. Eagle Clarke, *British Association Report*, 1901, p. 10), the individuals which are 10 summer in Scandinavia passing through this country after our own swallows have arrived. Similarly, the return of the Scandinavian swallows also appears to be somewhat later than ours (middle of September, p. 12). (See also the same author's "Digest," *British Association Report*, 1896, p. 17).

ment is to obtain more extended daylight. This, however, is not to be wondered at, since the quest of daylight is itself only a part of the greater problem of food supply. Any condition, local or other, which tends to restrict food supply in a particular area must produce migration from that area into more favoured areas. This is alone sufficient to account for the winter migrations which many birds exhibit, sometimes to a large extent, and for the localised migrations which some species, not usually regarded as migrants, exhibit in spring and autumn, moving from one area into another, not necessarily in a different latitude, although often of a different altitude. Further, it must be borne in mind that some birds, and those not few in number, find both sufficient food and sufficient daylight to acquire it in the same region all the year round, and exhibit no tendency to migrate. This can in no way be employed as an objection to the view that the true north-south migrants have been driven to seek more extended daylight for the purposes of obtaining a sufficiency of food; it would equally apply to any other explanation that might be given to account for the migratory tendency, and could only be used to prove that there is no necessity for any migration at all, which, as Euclid would say, is absurd. Given a food supply adequate in nature and amount to maintain the species in any region, and sufficient light all the year round to procure it, there would be no need for migration.

But these are not, and never have been, conditions which obtain in all regions and for all species. On the contrary, a very large number of species appear to require the prolonged daylight of the northern summer to procure a sufficiency of food for themselves and their offspring, while, apart from severity of climate, the shortened hours or absence of daylight which supervene there necessitate that they should pass the winter months in southern latitudes. Thus we can comprehend how the north-south migratory instinct became evolved, and we no longer wonder at the existence of this phase of the phenomenon. That the great east-west migrations are more complex and more difficult of explanation I am free to admit, but it must not be forgotten that we know, on the whole, less about these, and especially less about the climatic and other conditions which accompany them and may be supposed to produce or influence them, than we do about the influences to which the north-south migrants are exposed. The fact that we are not in a position to solve the whole of a complicated problem need not prevent our attempting to deal with any part for which our existing knowledge enables us to devise an explanation. If I have approached the question entirely from a physiological aspect, it is because it is in the main a physiological question. Nevertheless, no physiologist has hitherto attempted to deal with the subject, and it is only with diffidence that I encroach upon a domain which the morphologist has up to the present regarded as his own.

CRETAN EXPLORATION.

AN appeal is made by Dr. Arthur J. Evans, F.R.S., for funds to complete the excavation of the "Palace of Minos," which has now been carried on for seven years. At the beginning of the present year it was thought that supplementary explorations on a comparatively small scale would be sufficient, and that by the close of the season something like finality might be attained as regards at least the palace site of Knossos. This forecast, however, was by no means borne out by the result. The season's work, which was intended to be of a more or less supplementary nature, broadened out into a somewhat extensive excavation, the result of which is to show that another great campaign must be carried through before the excavation of the palace site at Knossos approaches completion. It is estimated that at least another 3000l. is required to complete the work, and this must be met by public subscription, for, as Dr. Evans points out, in this matter it is unfortunately impossible for an English explorer to rely, like his French, German, and Italian colleagues, on Government grants or large subventions from national academies. Writing in support of the appeal in the *Times* of November 21, Prof. C. Waldstein, referring to Cretan exploration as a scien-

tific labour which has brought credit to the British nation all over the world, says:—"In any other European country the Government would have subsidised, if not paid, all the expenses of what can in no way be considered a private enterprise. . . . Does not a wider public take some interest in the higher research carried on by the scientific representatives of the nation, and can the wealthier classes in England not be brought to give material support to the efforts of those who thus stand for the nation's higher culture? Is it impossible to hope for a Government subsidy? If it be not the 'tradition,' good traditions can be inaugurated by those who lead the nation. No amount of immediate effort to raise our industries by direct technical education will prepare us to cope with the competition of the other leading nations of the world. We must raise the tone of intellectuality by arousing the national interest in the highest forms of intellectual life." Subscriptions for the Cretan Exploration Fund can be sent either to Mr. G. A. Macmillan, St. Martin's Street, W.C., or to Messrs. Roberts, Lubbock, and Co., Lombard Street.

A LUNAR "NEW JERUSALEM."

A PAMPHLET has been received containing a series of lectures by the Rev. G. B. Berry on "The New Jerusalem," with a preface by the Lord Bishop of Exeter. With the spiritual interpretation of the Apocalypse we are not concerned in these columns, but an astonishing speculation put forward in the last lecture demands a word of comment. Mr. Berry suggests that the invisible part of the moon has the same size and shape as the mighty pyramid which, according to Revelation, forms the heavenly Jerusalem. Eventually the lunar hemisphere visible to us is to bury itself in the earth, and the pyramidal portion is to project above "the rack and ruin of the elements" caused by the catastrophe, and to be the Celestial City in which the faithful will pass eternity. As a vision, this picture may appeal to imaginative minds, but from the point of view of celestial mechanics it can scarcely be taken seriously. A pyramid of the dimensions of that upon which Mr. Berry's New Jerusalem rises tier upon tier would be crushed by its own weight even if it were built of steel. As, however, the structure is visionary, we imagine that this material fact affords no valid objection to it. The changed moment of inertia of a moon with the invisible side of a pyramidal form would necessitate modification of the whole theory of the physical librations of our satellite; but perhaps Mr. Berry does not appreciate the force of this difficulty. He is certainly not familiar with the theory of tidal friction or with the fact that Laplace, who studied the physical librations, showed that one side of the moon always faces the earth because that position is one of dynamical stability. A fuller knowledge of celestial mechanics might have made Mr. Berry hesitate before erecting such a visionary structure as he describes upon so slender a foundation. His views would have pleased mediæval schoolmen, but modern science demands that even the most fascinating hypothesis should be based upon results of observation capable of being put to the test of inquiry rather than upon "revealed truth" to be accepted without criticism.

UNIVERSITY AND EDUCATIONAL INTELLIGENCE.

THE governing body of the South-Western Polytechnic has appointed Dr. Louis Lownds head of the department of physics. Dr. Lownds is the author of papers on the thermoelectric and thermomagnetic properties of bismuth crystals and on other subjects. Dr. W. H. Eccles, formerly head of the joint mathematical and physical department, has been made head of the department of mathematics.

THE annual distribution of prizes and certificates at the Borough Polytechnic Institute was held on Thursday, December 12, when Sir Edward Carson, K.C., M.P., presented the prizes and delivered an address. Mr. Spicer, the chairman of the governing body of the institute, in the course of his remarks referred to the building extension

which is now being carried out at the polytechnic, at a cost of 12,000*l.*, toward which the late chairman of the governing body, Mr. Edric Bayley, has generously contributed the sum of 5000*l.*, the remainder being made up by a grant from the London County Council. Mr. C. T. Mills, the principal, in his report, stated that there were nearly 3000 individual students in attendance during the first session, of whom 330 were day students.

We have received the calendar of the Camborne Mining School, Camborne, for 1907-8. This school, now in the twentieth year of its existence, has rapidly expanded, and has proved very successful in giving facilities to students for acquiring a thorough knowledge of metalliferous mining. The success has been largely due to the organization of a systematic course of practical mining, the South Conduarrow, now known as the King Edward mine, having been purchased for the purpose in 1897. Students there obtain an acquaintance with practical mining, ore dressing, and engine testing, as well as practice in mine surveying under the supervision of practical men under the direct

its present stage. The work at South Kensington, as is well known, is largely due to his instigation and interest, and the new Technological Institute which will begin in the coming year will be a natural outcome of that work. By means of it we hope to be brought more into line with other nations."

SOCIETIES AND ACADEMIES.

LONDON.

Royal Society, November 7.—"The Diurnal Variation of Terrestrial Magnetism." By Prof. Arthur Schuster, F.R.S.

In a previous communication (Phil. Trans., vol. clxxx., p. 467, 1889) the author proved that the diurnal variation of terrestrial magnetism had its origin outside the earth's surface, and drew the natural conclusion that it was caused by electric currents circulating in the upper regions of the atmosphere. If we endeavour to carry the investigation a step further, and consider the probable origin of these



View underground in King Edward Mine.

authority of the school. Moreover, in consequence of the situation of the school in the centre of the chief mining district of Cornwall, students have the privilege of visiting the mines. The calendar is illustrated by a number of admirable photographic views, many of which have been taken by Mr. J. C. Burrow, the leading exponent of underground photography. The photograph here reproduced represents the so-called "cathedral" at the 400-foot level of King Edward mine.

MR. HALDANE, M.P., unveiled a statue of the King at University College School, Fognal, Hampstead, on Saturday, December 14. The statue has been erected in a niche above the main entrance, and is presented to the school by the architect, Mr. Arnold Mitchell, in commemoration of the opening of the school by the King on July 25. In a subsequent address Mr. Haldane said:—"There is no subject of greater general importance than education, and if Prince Albert had lived there is no doubt that education would have been ten years in advance of

currents, we have at present no alternative to the theory, first proposed by Balfour Stewart, that the necessary electromotive forces are supplied by the permanent forces of terrestrial magnetism acting on the bodily motion of masses of conducting air which cut through its lines of force. In the language of modern electro-dynamics, the periodic magnetic disturbance is due to Foucault currents induced in an oscillating atmosphere by the vertical magnetic force. The problem to be solved in the first instance is the specification of the internal motion of a conducting shell of air, which shall, under the action of given magnetic forces, determine the electric currents producing known electromagnetic effects. Treating the diurnal and semi-diurnal variations separately, the calculation leads to the interesting results that each of them is caused by an oscillation of the atmosphere which is of the same nature as that which causes the diurnal changes of barometric pressure.

The mathematical analysis is simple so long as we take the electric conductivity of the air to be uniform and constant; but the great ionisation which the theory demands

requires some explanation, and solar radiation suggests itself as a possible cause. Hence we might expect an increased conducting power in summer and in day-time as compared with that found during winter and at night. Observation shows, indeed, that the amplitude of the magnetic variation is considerably greater in summer than in winter, and we know that the needle is at comparative rest during the night. The variable conducting power depending on the position of the sun helps us also to overcome a difficulty which at first sight would appear to exclude the possibility of any close connection between the barometric and magnetic variations; the difficulty is presented by the fact that the change in atmospheric pressure is mainly semi-diurnal, while the greater portion of the magnetic change is diurnal. This may, to some extent, be explained by the mathematical calculation, which shows that the flow of air giving a twenty-four-hourly variation of barometric pressure is more effective in causing a magnetic variation than the corresponding twelve-hourly variation, but the whole difference cannot be accounted for in this manner. If, however, the conductivity of air is greater during the day than during the night, it may be proved that the twelve-hourly variation of the barometer produces an appreciable periodicity of twenty-four hours in the magnetic change, while there is no sensible increase in the twelve-hourly magnetic change due to the twenty-four-hourly period of the barometer.

A good test of the proposed theory may be found in a closer examination of the diurnal magnetic changes in the equatorial regions, because, owing to the inclination of the magnetic to the geographical axis, the magnetic changes ought to have a term which does not depend on local time, but on the time of the meridian containing the geographical and magnetic pole. This term has its greatest importance at the equator and at the time of the equinox.

The value of the conductivity necessary to explain the diurnal variation in the manner indicated depends on the thickness of the layers which carry the currents. If e be the thickness and ρ the conductivity, and the amplitude of oscillation in the upper layers is assumed to be the same as that deduced from the barometric variation, it is found that $\rho e = 3 \times 10^{-12}$. If e is equal to 300 kilometres, the conductivity would have to be as high as 10^{-15} , while the observed conductivity of air at the surface of the earth under normal conditions is of the order 10^{-29} ; at a height at which the pressure is reduced to one degree per square centimetre, the conductivity would be 10^{-18} , assuming the rate of re-combination to be independent of temperature and the ionising power to be the same. The conclusion is that there must be a powerful ionising agent in the upper layer of the atmosphere.

November 21.—“The Silver Voltmeter.” Part I. “On a Comparison of many Forms of Silver Voltmeters.” By F. E. Smith; and “A Determination of the Electrochemical Equivalent of Silver.” By F. E. Smith and T. Mather, F.R.S.

Part II. “The Chemistry of the Silver Voltmeter.” By F. E. Smith and Dr. T. M. Lowry. Communicated by Dr. R. T. Glazebrook, F.R.S.

Part I.—Very large voltmeters were experimented with. Four of the kathode bowls had a capacity of 500 c.c. each, and in general from 300 c.c. to 400 c.c. of electrolyte were employed. The anodes were coated with electrolytic silver. With a Rayleigh form of voltmeter containing an electrolyte of pure silver nitrate, the mean of fifty-two determinations of the electrochemical equivalent of silver was 1.1827 milligrams per coulomb, the current being indirectly measured by the Ayrton-Jones balance. With a Richards's form of voltmeter, in which the pot had previously been baked in an electric furnace, the value 1.1828 was obtained, and with a syphon and other modified forms of voltmeter the value 1.1827 resulted, pointing to little or no irregularities in the large-size Rayleigh form of voltmeter. Deposits were made when the voltmeter was subject to a gaseous pressure of 2.4 cm. of mercury, and were found to be identical with those made at atmospheric pressure. The temperature coefficient is probably nil, and is not greater than 1 part in 1,000,000 per $^{\circ}$ C. The range in the current intensities was from 0.5 ampere to 8 amperes.

Part II.—Before a definite value could be assigned to the electrochemical equivalent of silver it was necessary to demonstrate that silver nitrate solutions, giving constant products, could be obtained. This was done by preparing silver nitrate from electrolytic silver, from much used silver nitrate, and from commercial samples of the salt. Attempts to confirm the observations of Novak, Rodger and Watson, Kahle, van Dijk, and others, on the effect of repeated electrolysis of a solution, show that in the form of voltmeters described in Part I. there is no increase in the deposit with continued use of a solution which is comparable with that obtained by the observers mentioned. High values for the electrochemical equivalent are obtained if the solution contains oxide, carbonate, chloride, nitrite, or hyponitrite; low values are caused by acid. Silver chloride and silver perchlorate appear to give normal deposits, but are more troublesome in use, and have no advantage over the nitrate.

“On the Normal Weston Cadmium Cell.” By F. E. Smith. Communicated by Dr. R. T. Glazebrook, F.R.S.

In the past many investigators have pointed out that the depolariser may produce variations in the E.M.F. so great as 0.002 volt. A mode of manufacture of mercurous sulphate was first sought which could be relied on to give a constant product. The salt was prepared in four ways:—(1) electrolytically; (2) by chemical precipitation; (3) by re-crystallisation from a solution in strong sulphuric acid; (4) by the action of fuming sulphuric acid on mercury. The mean E.M.F. of the cells set up with the electrolytic salt is 1.01828 volts; with No. 2 product, 1.01830 volts; (3) gives 1.01832 volts, and (4) 1.01831 volts. The effect of the size of the crystals of the depolariser, to the importance of which attention has been directed by H. v. Steinwehr, was investigated by using crystals varying in size from 5 to 30 microns, and it is concluded that no large crystals which are sufficiently soluble to act as an efficient depolariser can give an E.M.F. appreciably lower than that due to crystals from 5 to 30 microns long. The recuperative power of the cell was tested by short-circuiting for from one minute to five days. The temperature coefficient for the range 10° C. to 30° is given by

$$E_t = E_{17} - 3.45 \times 10^{-8}(t - 17) - 0.066 \times 10^{-9}(t - 17)^2.$$

Geological Society, November 20.—Sir Archibald Geikie, K.C.B., Sec.R.S., president, in the chair.—Glacial beds of Cambrian age in South Australia: Rev. Walter Howchin. The known extension of these beds is 460 miles from north to south. The greatest width across the strata is about 250 miles. The beds form part of a conformable series, with Cambrian fossils in the upper part. The rocks above the glacial beds are purple slates and limestones; below they are quartzites, clay-slates, and phyllites, passing into basal grits and conglomerates, resting on a pre-Cambrian complex. The beds consist of a ground mass of unstratified indurated mudstone, carrying boulders up to 11 feet in diameter. The thickness of the glacial series has been proved up to 1500 feet. The commonest rock-type among the boulders is a close-grained quartzite. The discovery of ice-scratched boulders has indicated the origin of the beds. The strata are often as distinct as those in a Pleistocene Boulder-clay. Eighty definitely glaciated boulders have been secured, and other erratics too large for removal noted. Under pressure and movement in their bed some boulders exhibit abrasion, but this produces features not to be confounded with glaciation. In the movement due to pressure, which induced cleavage, some stones have become distorted, and many show pseudo-striation on exposed surfaces. The lines, however, are of equal size and depth, and parallel to each other over wide surfaces, while the glacial striae are patchy in their occurrence, of varying intensity, and divergent in direction. Mr. H. P. Woodward's suggestion, that the “Boulder-clay” had its origin from “floating ice,” is considered most in accordance with facts.—A formation known as “glacial beds of Cambrian age” in South Australia: H. Basedow and J. D. Iffie. Eight miles south of Adelaide an exposure of the conglomerate is bounded to the east by alternating quartzitic and argillaceous bands of rock, comprising the central and western portions of a fan-fold, partly cut off by a fault. Further evidence of stress in this margin is given. On

the west side the conglomerate is bounded by the "Tapley's Hill Clay-slates," and there is evidence that the conglomerate is isoclinally folded. In that portion of the conglomerate adjacent to its confines, "boulders" of quartzite are apparently disrupted portions of quartzite-bands, since these are in alignment with the truncated portions of bands still existing, and are of similar composition. The presence in the conglomerate of boulders of rocks foreign to the beds that border the conglomerate is not yet accounted for.

Entomological Society, November 20.—Mr. G. H. Verrall, vice-president, in the chair.—**Exhibits.**—W. West: Examples of *Tropideres septicola*, F., taken in the New Forest near Matley Bog, July 7, 1904; *Oxytaenus variolosus*, Duf., from Darenth Wood, March 2, 1903; and *Apion annulipes*, Wenck, from Darenth Wood, August 27, 1905.—H. J. Turner: Two cases to show the complete life-histories of *Coleophora onosmella* and *C. bicolorata*.—Dr. F. A. Dixey: Several species of five African genera of Pierine butterflies for the purpose of showing the strong mimetic parallelism that existed between them.—W. Gardner: A remarkably small specimen of *Meloe proscarabaeus*, with an example of the normal size.—W. G. Sheldon: A case containing many examples of *Araschnia levana*, var. *prorsa*, and intermediates, bred from larvae found in the department of the Aisne, France, in June last.—Dr. T. A. Chapman: Specimens of *Araschnia levana*, type, bred 1907, to give a fuller view of this form in assistance to Mr. Sheldon's report.—Mr. Sheldon also showed strings of the ova *in situ* on nettle, these being base to apex, and in position resembling those of *Polygonia a-album*.—G. Arrow: A specimen of a handsome exotic cockroach (*Dorylaea rhombifolia*) found alive in the Natural History Museum, one of an apterous species inhabiting China, India, Madagascar, South Africa, &c.—Dr. G. B. Longstaff: A case containing thirty-five Ithomiine butterflies of eleven species, belonging to six genera, taken at Caracas, Venezuela, some 3000 feet above sea-level, and affording a striking exception to Darwin's principle that closely allied forms are not usually found together.—Lieut.-Colonel N. Manders: A collection of some 200 specimens of tropical butterflies belonging to the genera Melanitis, Mycalesis, Atella, Papilio, and Catopsilia, which had been subjected to abnormal degrees of temperature, mostly in the pupal stage. The object of the experiments was to ascertain the effect of climate on the colours of tropical butterflies.—W. J. Kaye: A convergent group of Heliconine butterflies, from the Potaro Road, Potaro River, British Guiana.—**Papers.**—Mimicry in North American butterflies of the genus *Limenitis* (Basilarchia): Prof. E. B. Pouton.—The life-history of *Lomocosa strumosa*, F.: H. St. J. Donisthorpe.

Chemical Society, December 5.—Sir William Ramsay, K.C.B., F.R.S., president, in the chair.—The affinity constants of bases determined by the agency of methyl orange. Preliminary note: V. H. Veley. The author has applied his titimetric method to the determination of the degree of hydrolysis of hydrochlorides of a large number of organic bases ranging in type from hydroxylamine to cinchonidine. Several results are found to be in accordance with the expression of Arrhenius, $k_1/k_2 = (1-x)/v^2x^2$, whilst in the case of bases of analogous composition the ratio of the hydrolysis values found is nearly equal to the ratio of the heats of neutralisation with hydrochloric acid.—The constituents of essential oil of nutmeg: F. B. Power and A. H. Salway. Ceylon nutmeg oil contains eugenol, isoeugenol, *d*-pinene, *d*-camphene, dipentene, *d*-linalool, *d*-borneol, *i*-terpinol, geraniol, a new alcohol yielded on oxidation a diketone, a citral-like aldehyde, safrole, myristicin, myristic acid (free and in the form of esters), formic, acetic, butyric, and octoic acids, and a new monocarboxylic acid, $C_{13}H_{14}O_2$, all in the form of esters.—The resolution of *sec*-octyl alcohol: R. H. Pickard and J. Kenyon. *d*-*sec*-Octyl hydrogen phthalate is obtained by fractional crystallisation of the brucine salt from acetone and the *l*-salt by fractional crystallisation of the cinchonidine salt from aqueous acetone.—The velocity of reduction of the oxides of lead, cadmium, and bismuth by carbon monoxide, and the existence of the suboxides of these metals: F. J. Brislee. The results of the experi-

ments confirm Tanatar's statement that the suboxides are definite chemical compounds, but do not prove their stability.—The relation between unsaturation and optical activity, part I., the menthyl and bornyl esters of β -phenylpropionic, cinnamic, and phenylpropionic acids: T. P. Hilditch. The boiling points and specific gravities increase with increase of unsaturation, but the refractive indices rise with the change to an ethylenic linking, but fall to an intermediate value for the further change to an acetylenic linking. Walden's view that increase of saturation is accompanied by increase of optical rotation is confirmed so far as the change to an ethylenic linking is concerned, but not with reference to the effect of a triple bond on the optical rotation.—Methyl ethers of some hydroxyanthraquinones: A. G. Perkin.—The colouring matters of the stilbene group, part iv., action of caustic alkalis on *p*-nitrotoluene and its derivatives: A. G. Green, A. H. Davies, and R. S. Horsfall.—The replacement of alkyl radicles by methyl in substituted ammonium compounds: H. O. Jones and J. R. Hill. The authors find that in amines or quaternary ammonium compounds the ethyl, propyl, isopropyl, butyl, isobutyl, and isoamyl groups are all replaced by methyl, sometimes in the cold, but more easily on heating with methyl iodide.—Note on the formation of abnormal platinumchlorides. A correction: A. E. Dunstan. The three platinumchlorides of the type $B_3H_7PtCl_6$, described previously, are now found to belong to a group of such substances already noted by Werner and others.—The nitrates of dimethyl- and methyl-ethyl-thetine menthyl esters: S. Smiles. These were prepared by precipitating aqueous solutions of the bromides with aqueous ammonium nitrate.—Synthesis of braziliin acid and the lactones of dihydrobraziliin and dihydrohaematoxylin acids. Preliminary note: W. H. Perkin and R. Robinson. Braziliin acid is formed when trimethylbraziliin is oxidised by permanganate, and on reduction is converted into the lactone of dihydrobraziliin acid. Braziliin acid is produced synthetically by condensing meta-hydroxyphenoxyacetic ester with meta-hemipinic anhydride, and must be represented by the following formula (I):—

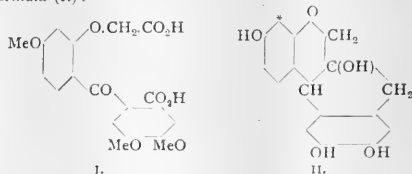

From this and other syntheses it is concluded that braziliin, the colouring matter of Brazil wood, must be represented by the constitutional formula (II.) first assigned to it by Werner and Pfeiffer, and that haematoxylin, the colouring matter of logwood, is derived from that of braziliin by the introduction of a hydroxyl group at the point indicated by the asterisk in formula (II.).—Condensations of ketones containing the group



with esters in presence of sodium ethoxide: R. W. L. Clarke, A. Lapworth, and E. Wechsler.—Acyllogens and thiocarbamides: A. E. Dixon and J. Taylor.—The alkyl compounds of gold: W. J. Pope and C. S. Gibson.—The refractive power of diphenylhexatriene and allied hydrocarbons: Miss I. Smedley. The results recorded show that in each case the refractive power of the group increases with the number of unsaturated groups present, and that the influence of the hexatriene structure is always greater than that of the benzene ring.

Royal Anthropological Institute, December 3.—Prof. W. Gowland, ex-president, in the chair.—Some Papuan children's games: Captain F. R. Barton. The games dealt with are those played by children in British New Guinea, and included fishing games, cat's cradle, hide and seek, and others. Whilst the games are being played the children sing, and the songs are of particular interest, as in many cases the words are quite archaic, and the meaning has been lost.

CAMBRIDGE.

Philosophical Society, October 28.—Dr. Hobson, president, in the chair.—The longitudinal impact of metal rods with rounded ends (second paper): J. E. Sears. In this paper the effect of the rounded ends is discussed mathematically by means of a combination of the theories of Hertz and St. Venant. Further experimental results are brought forward for purposes of comparison. In these experiments rods of unequal lengths were used, and observations made both of the durations of impact and of the velocities of rebound. The results in nearly every case agreed within 1 per cent. with those given by the theory. Interesting laws are found for the variation in the duration of the impact when the length of one of the rods is continuously increased, and also for the case when the velocity of impact is allowed to vary. The paper concludes with a suggestion as to the application of the theory to plane-ended rods, and a calculation of the stresses set up at the ends of the rods during impact.—The fatigue of secondary radiation due to radium rays: J. A. Crowther. The object of the experiments was to ascertain if the continuous impact of the radium radiations upon a metal plate over a prolonged period of time produced any alteration in the amount of secondary radiation given out by the plate. Experiments were made both with the β and γ rays, and also with the α rays. The results of the experiments showed (1) that the continuous impact of radium rays upon a metal plate does not cause any diminution in the amount of secondary radiation given out by the metal under the action of the radium rays themselves; (2) that the continuous impact of radium rays upon a metal plate does produce an alteration in the amount of secondary radiation given out by the plate under the action of Röntgen rays; (3) that the continuous action of radium rays produces a very marked diminution in the amount of secondary radiation given out by the plate under the action of ultra-violet light.—Laws of motion: P. V. Bevan.—Ionisation by ultra-violet light: Prof. Thomson.—The asymptotic approximation to functions defined by highly convergent product forms: J. E. Littlewood.

PARIS.

Academy of Sciences, December 9.—M. A. Chauveau in the chair.—An apparatus designed for stars composed partly of gas and partly of solid particles, and capable of giving separately the image of each of the two elements: H. Deslandres. A photograph of the star spectrum is made, and from the negative a screen is made with a diaphragm cutting out any desired lines, and this screen is placed in the focal plane of the spectrum. A diagram of the complete apparatus is given, which is arranged so that the spectrum photographed may include either the lines of both gas and solid particles or those of the gas or particles separately. The apparatus is easily applicable to comets, nebulae, the middle and upper chromosphere of the sun during eclipses, and even the corona.—The supposed poisonous nature of Hungarian beans: L. Guignard. Contrary to the results obtained by MM. Evesque, Verdier, and Bretin, the author has not been able to obtain the smallest trace of hydrocyanic acid from Hungarian beans (*Haricots de Hongrie*). The method of estimation of the hydrocyanic acid used by the above-mentioned chemists is subjected to a critical examination, and the author's own method described in detail.—The claims of M. Loeb in the question of experimental parthenogenesis: Yves Delage. A reply to some criticisms of M. Loeb on the author's work.—Some Lepidostrobos from the Pyrenees region: R. Zeiller. Three illustrations of the fossil are given.—The direct hydrogenation of some aromatic diones: Paul Sabatier and A. Mailhe. The direct hydrogenation by means of reduced nickel of the aromatic diones gives results corresponding to the ordinary hydrogenation of these ketones, aromatic hydrocarbons being formed. Benzil and benzoin gave symmetrical diphenylethane. Benzoylpropanone gave principally butylbenzene.—The visibility of Saturn's ring at the present time: J. Guillaume. An account of the appearance of the ring on the night of November 23. The results confirm the observations of W. C. Bond and of Secchi.—The Giacobini comet 1907a: MM. Giacobini and Javelle.

Observations of the position of the comet were taken on December 4, 6, and 7. The comet had a stellar appearance of about 15^m diameter, and showed a nucleus of the fourteenth magnitude.—Observation of the transit of Mercury of November 14 made at the Fabra Observatory at Barcelona: J. Comas Solà. The conditions of observation were good. The times of the second, third, and fourth contacts are given. The mean of five observations of the equatorial diameter was $8^{\cdot}94$, the form of the planet being sensibly circular.—Certain ruled surfaces: M. Taitzeica.—The permutation of the integrals of a system of differential equations: A. Buhl.—The function $D(\lambda)$ of Fredholm: T. Lalesco.—The systems of partial differential equations leading to (1) the study of the finite deformations of a continuous medium in space of n dimensions; (2) the determination of the systems of orthogonal curvilinear coordinates with n variables: M. Riquier.—General mechanics: Eugène and François Cosserat.—An electromagnetic compass particularly suitable for armoured blockhouses and submarines: Louis Dunoyer. The transmitting compass is placed in a part of the ship where the field gives no trouble, or may be compensated, the readings being transmitted by the arrangement described to the receiver, from which the ship is steered.—The number of free electrons of metals and the electromotive series: V. Schaffers.—The condensation of water vapour in the presence of the radium emanation: Mme. Curie. Moist air containing the radium emanation always contains a fine fog more or less opaque, and formed of very fine particles. A very much smaller amount of water vapour than that required for saturation is sufficient to produce this phenomenon, but it is not produced when the air is perfectly dry. This effect is quite separate from the known phenomenon of condensation of water vapour by gaseous ions.—The lithium contained in radio-active minerals: Mlle. Gleditsch. In view of the observation of Sir William Ramsay that radium transforms copper into lithium, it appeared of interest to see if minerals which contain both copper and radium also contain lithium. In agreement with the result of McCoy (NATURE, November 28), Joachimsthal pitchblende has been found to contain a minute amount of lithium.—Singing flames and tubes with flames of several notes: M. Athanasiadis. Experiments are described showing that a manometric flame can produce a perceptible sound, the number of vibrations of which is equal to the number of vibrations of the manometric membrane. A manometric flame can also produce simultaneously two or more notes.—The use of very low temperatures for spectrum analysis and for the study of magneto-optic phenomena in solutions: Jean Becquerel.—The propagation of telephone currents through subterranean lines: Henri Abraham and M. Devaux-Charbonnel. Underground telephone lines are only available for very moderate distances; the pitch of the notes exercises a considerable influence on the power of transmission to large distances, low voices being better transmitted than high ones, as the line absorbs the high harmonics.—The saturation intensity of magnetisation of iron and nickel: Pierre Weiss.—The application of the law of Poiseuille to the measurement of high pressures: A. Perot. The volume of water forced through a very fine capillary tube, applying Poiseuille's law, has been used as a basis of a manometer for high pressures, 300 kg. per sq. cm. The accuracy was found to be about 0.5 per cent.—The use of heavy hydrocarbons for lighting: Louis Denayrouze.—The action of an incandescent electric conductor on the gases which surround it: M. Couriot and Jean Meunier. An explanation is put forward of the cause of the non-inflammation of certain explosive mixtures of oxygen and hydrocarbons by means of a wire carried to incandescence by electricity. It is assumed that the wire repels the oxygen molecules and attracts those of the hydrocarbon, so that the actual composition of the gaseous zone immediately round the wire is not in explosive proportions.—The method of limiting densities and its application to the atomic weight of nitrogen: Ph. A. Guye. An answer to some criticisms of M. Daniel Berthelot. The author prefers to base his calculations on the idea of corresponding states rather than on that of limiting densities, and compares the two methods in detail as applied to the experimental ratios $N_2O:O$, $N_2O:N_2$, $N_2:O$, $NO:O$, $NO:N$, and $N:O$. These lead to a mean value

for the atomic weight of nitrogen of 14.010 instead of the 14.005 of M. Berthelot.—The non-existence of a common solvent for white and red phosphorus: Alb. **Colson**. The author has been unable to dissolve red phosphorus in essence of turpentine, and there seems to be no solvent known which will dissolve both varieties.—The equilibrium of the nickel-bismuth system: A. **Portevin**. The state of equilibrium is only attained for alloys of the pure metals.—An apparatus designed for the production of spark spectra of solutions: A. **de Gramont**. In the apparatus, a drawing of which is given, the spark is produced between two drops of the liquid held up in capillary tubes of fused quartz. The spectra are free from the lines of platinum and silicon.—The identity of graphite and the graphitic carbon set free from castings during tempering: Georges **Charpy**. The experiments described lead to the conclusion, contrary to the views of Forquignon and Wust and Geiger, that these two forms of carbon are the same.—The action of phosphorus trihydride on mercuric chloride and bromide: P. **Lemout**.—Carbon monoxide in coal gas: Léo **Vignon**. The larger the amount of oxygen in the coal the larger is the proportion of carbon monoxide and dioxide in the gas obtained from it. At a temperature of 900° C., rather less than one-third of the oxygen of the coal is found in the gas in the form of these two oxides.—The transformation of barbaloin into an isomeric aloin: β -barbaloin and the existence of the latter in several kinds of aloes: E. **Leger**.—The dissociation of combinations of colouring acids to basic colours by adsorbing substances: L. **Pelet-Jollivet**.—Sparteine. The isomerisation of α -methyl-sparteine: Charles **Moureu** and Amand **Valour**.—The synthesis of symmetrical phenylated anilidophenosafranine: Ph. **Barbier** and P. **Eisley**.—The deposit of evergreen copper: Etienne A. **Ritter**.—The occurrence of granite in the diamond-bearing chimney of De Beers: L. **De Launay**. Some time ago the author predicted that granite would be encountered in a boring at Kimberley at a depth of about 600 metres, and his views have been confirmed by the discovery of granite in this chimney at a depth of 641 metres.—Remarks on the affinities of the Malpighiaceae of Madagascar, concerning the new genus *Tricomariopsis*: Marcel **Dubard**.—The variations of dry weight in the higher plants under different luminous intensities: W. **Lubimenco**.—The influence of the hygrometric state of the air on the preservation of seeds: E. **Demoussy**. When the hygrometric state, at 25° C., is above 0.7, many seeds rapidly perish, the seeds of the *Cruciferae* being the most resistant.—The inosites from *Gui*: Georges **Tanret**.—A colour reaction for use with fungi: L. **Arnould** and A. **Goris**.—The fatigue of earth: I. **Pouget** and D. **Chouchak**.—Two hybrids of the peacock and Cochín China fowl: G. **Pays-Mellier** and E. **Trouessart**.—Histology of the muscles after the nuptial flight in ants: Charles **Janet**.—The periodic variations of sign of phototropism in *Cibavarius misanthropus*: Mlle. Anna **Drozwinia**.—The action of the ichthyotoxins on the nervous system of animals immunised against these substances. Contribution to the study of immunity: E. **Gley**.—The favourable influence of small doses of zinc on the vegetation of *Sterigmatocystis nigra*: Maurice **Javillier**.—The presence of phosphorus in the fatty material of microorganisms: E. **Aixlaire**.—The conditions of hydrolysis of the protoplasmids: A. **Etard** and A. **Vila**.—The effects of light on the vision: Jules **Amar**. Excluding pathological conditions, an excess of light puts the eyes into a bad condition for their normal working.—The influence of the illumination round the observer on the acuteness of vision for night signals in navigation: André **Broca** and M. **Polack**.—The presence of yeasts in the fatty bodies of several *Coccidia*: A. **Conte** and L. **Gaucheron**.—The trypanolytic property of the serum in experimental nagana: A. **Ridet** and G. **Vallet**.—The pathology of glaucoma: A. **Terson**.—The death of infants by the thymus and in chloroform anaesthesia. Anatomical, physiological, and clinical study: R. **Robinson**.—The action of chlorine on the tubercle bacillus: MM. **Moussu** and **Goupil**.—The presence of the Trias in the mountains of Gignondas (Vaucluse), and the phenomena of *charriage* which are observed in this *massif*: L. **Joleaud**.—The Neocretaceous of Argolide: Ph. **Négris** and Const. A. **Ktenas**.—The

discovery of vertebrates in the Oligocene of Fronsadais, basin of the Gironde: G. **Vasseur**.—Some new fossil plants in the Sparnacene of the Paris region: P. H. **Fritel**.—Study of a specimen taken from the sea bottom of the Channel near the coast: J. **Thoulet**.

CALCUTTA.

Asiatic Society of Bengal, November 6.—Note on the common English merlin (*Esalon regulus*) and its training: Lieut.-Colonel D. C. **Phillott**.—A case of lateral floral proliferation of the inflorescence of the pine-apple—*Ananas sativus*, Schult. l.: Captain A. T. **Gage**. Descriptions with figures of a pine-apple surrounded by many small elongated pine-apples after the manner of a hen-and-chickens daisy.

DIARY OF SOCIETIES.

THURSDAY, DECEMBER 19.

CHEMICAL SOCIETY, at 8.30.—Derivatives of Tetramethyl Glucose: J. C. Irvine and A. M. Moodie.—The Characterisation of Mercered Cotton: Preliminary Note: J. Hübner.—Attempted Synthesis of β -N— β Di-naphthacridine; Condensation of Methylene Dichloride and β -Substituted-2-Naphthylamines: A. Senior and P. C. Austin.
LINNEAN SOCIETY, at 8.—On Mendelism and Sex: Dr. Archdald Reid.
INSTITUTION OF MINING AND METALLURGY, at 8.
INSTITUTION OF ELECTRICAL ENGINEERS, at 8.—Electrical Power in Railway Goods Warehouses: H. Henderson.

FRIDAY, DECEMBER 20.

INSTITUTION OF CIVIL ENGINEERS, at 8.—The Mechanical and Thermal Efficiency of a Petrol Engine: L. G. E. Morse.
INSTITUTION OF MECHANICAL ENGINEERS, at 8.—Notes on the Manufacture and Use of Milling Cutters: Dr. H. T. Ashdon.

CONTENTS.

PAGE

Mathematics in Botany	145
Organic Chemistry for Medical Students. By J. B. C. 146	
Our Book Shelf:—	
Ward: "Some Nature Biographies"; Kearton: "The Fairyland of Living Things."—R. L.	147
Verworm: "Physiologisches Praktikum für Mediziner."—W. D. H.	148
Hoyt and Grover: "River Discharge"	148
Westlake: "Constructions in Practical Geometry"	148
Letters to the Editor:—	
The International Memorial Statue of Lamarck.—Sir E. Ray Lankester, K.C.B., F.R.S.	149
Mulattos.—H. G. Wells	149
Nest Eggs of Platypus.—Prof. Gregg Wilson	149
Sulphur as an Insulator.—Rev. F. J. Jarvis-Smith, F.R.S.	149
Notes on Ancient British Monuments. III. (Illustrated.) By Sir Norman Lockyer, K.C.B., F.R.S.	150
The Increased Endowment of Universities	152
Notes	154
Our Astronomical Column:—	
The Maximum of Mira, 1906	158
A Further Observation of Comet 1907a	158
Spectroscopic Determination of the Rotation of the Sun	158
Newly discovered Spectroscopic Binaries	158
The Astrogaphic Catalogue	158
Stars having Peculiar Spectra	158
Weakened Lines in Sun-spot Spectra	158
Exhibition of Physical Apparatus. By C. H. L.	159
On the Incidence of Daylight as a Determining Factor in Bird-Migration. By Prof. E. A. Schäfer, F.R.S.	159
Cretan Exploration	163
A Lunar "New Jerusalem"	163
University and Educational Intelligence. (Illustrated.)	163
Societies and Academies	164
Diary of Societies	168

THURSDAY, DECEMBER 26, 1907.

ELECTRIC TRACTION.

Electric Traction. By Prof. Ernest Wilson and Francis Lydall. Two vols. Vol. i., Direct Current, pp. vii + 475; vol. ii., Alternating Current, pp. vii + 328. (London: Edward Arnold, 1907.) Price 15s. net each.

THESE is no announcement on the title-page that this work is a second edition of a book which appeared in 1897. This omission, however, is fully justified, for although technically the present work may be considered a new edition, it is in reality a new work. Progress during the last ten years has been so great that to bring the work up to date it had practically to be re-written and very greatly enlarged. Even in its present form of two handsome volumes, comprising together some 760 pages, the authors have not treated the subject exhaustively. This statement is not meant as a reproach, but simply as an illustration of the fact that the application of electric traction to tramways and railways has become so many-sided that an exhaustive treatise of the subject can hardly be expected. All that can be expected is that the authors should make a judicious selection of types and systems, and this expectation is on the whole fulfilled in the present work.

There is, however, one rather important omission, namely, the use of the three-wire system on direct-current railways, as suggested by Krizik and carried out by his firm on the Tabor-Bechyně line in Bohemia. It is true that the authors give on p. 416 a sketch of the circuits and a short description of the system adopted on the City and South London line, which is a three-wire system in the sense that the trains in one direction are worked from a positive 500-volt trolley and the trains in the other direction from a negative 500-volt trolley, but this is a far less advantageous system than that devised by Krizik, where the positive and negative side of the three-wire system are utilised in the same train, and the earth or rail return is only called into requisition in the event of a breakdown on one side of the system.

Of the two volumes the first is devoted to direct-current and the second to alternating-current railways. The treatment is mainly descriptive, without much criticism on the authors' part, and on the whole there is a tendency to give prominence to American designs or to English designs of American origin. This favouring of American work goes so far that the authors, whilst referring to standardisation of tramway motors as determined by the American Institute of Electrical Engineers, completely ignore the standard rating adopted by the International Association at the Milan Congress last year. Possibly they may think the American standard better, but that is no reason why they should keep their English readers in ignorance of the fact that there is a standard in use on the Continent of Europe which will have to be complied with by those firms who secure contracts on the Continent.

A little more than half of the first volume is given

NO. 1991, VOL. 77]

up to tramway work, and deals in succession with the motor, the controller, resistances, trolleys and bows, rolling stock including brakes, the track, overhead equipment, slot and contact systems, feeders, generating stations, car sheds, storage-battery traction and regenerative control. Approximately the same order in the treatment of details is followed in the part devoted to railways, with the addition of a chapter on substations. Then follows a chapter on cost of tramway work, which, being taken from actual practice, should prove very useful when getting out preliminary estimates, also a chapter on working expenses, traffic receipts and tramway accounts in general, and finally there is an appendix giving all the Board of Trade regulations.

As already remarked, the treatment is mostly descriptive, but not always complete. Thus the suspension of tramway motors is dealt with in only four lines on p. 78, and in the description of magnetic brakes we miss the magnetic friction brake on the axle, although magnetic track brakes are not only well described but also critically compared. The tables relating to turn-out, cross-over and transition curves on pp. 112 to 116 are well arranged, and will be found very useful in laying out the track. Also the details of overhead equipment are well represented, but we miss the bridge wire round the ears which has of late years been introduced as a precaution to avoid the trolley wire coming down in the event of its breaking, which, as is well known, takes place generally close to the ear.

As regards buffer batteries, the authors seem to be under the impression that Mr. Highfield made their use possible by his automatic reversible booster. This is not so. Buffer batteries have first been suggested by Dr. Edward Hopkinson in 1893 in a paper read before the Institute of Civil Engineers on the City and South London Railway, and very shortly after, the first buffer battery was installed by the Tudor Accumulator Co. in the power house of the Zurich tramways, the economic success being so remarkable that buffer batteries had become a quite regular feature in tramway power houses on the Continent long before Mr. Highfield designed his very ingenious system of boosting.

On p. 197 the authors show a diagram (Fig. 144) and call it a negative booster wrongly connected. In this case the booster is supposed to be a series machine driven at a constant speed. There is nothing wrong about its connection; the only wrong thing in the diagram is the direction of the current as marked by arrows. A moment's consideration will show that if the machine is run at the critical speed in relation to the resistance of the return feeder, it is the very best possible negative booster, since it will relieve the rails from return current to even a greater extent than the booster with excitation from the positive feeder.

The authors' treatment of the complicated subject of controllers is excellent. They always give first a diagram showing the principle and then the actual arrangement of circuits and contacts, thus rendering the study of an intricate subject comparatively easy. The same praise may be given to their way of working out running diagrams and the determination of the

best acceleration. They show that although high acceleration means low energy per ton-mile, it does not necessarily mean low running cost, because the cost of substations and feeders increases considerably with the acceleration provided for. All these matters are treated from a thoroughly practical point of view.

The second volume begins with a chapter on the theory and design of the polyphase railway motor, with useful examples of such motors as applied to the Valtellina and other lines; then follows control, overhead equipment, rolling stock, energy consumption, and other details. In view of the increasing importance of single-phase working, the authors have done well to restrict the three-phase part of the book and to devote the space saved to the more recent single-phase system. Here they break new ground by going at some length into the question of single-phase commutator motors, both with and without commutating poles, compensating winding, and other refinements. There is, however, a certain ambiguity about the motors described, and the reader will not find it easy to know what particular type is meant, especially as diagrams of windings and vector diagrams are too sparingly used. Neither will he find mention of the designers by the names of which particular motor types have become known; there is no mention of Lamme, Fynn, Winter-Eichberg, Richter, Latour, and so on, yet each of these men have produced distinct types. To give an instance of the ambiguity: we are told that the London Bridge to Victoria line is being equipped with "compensated repulsion motors," but nothing is said of the particular type being the Winter-Eichberg.

The chapter on overhead work is distinctly good, both as a theoretical treatise and as a collection of examples from the best modern practice, whilst the chapters on feeders, inductive drop in rails, energy consumption, and capital outlay on single-phase railways will repay careful study on the part of the engineer who has work of this kind to design.

GISBERT KAPP.

VETERINARY ANATOMY.

The Surgical Anatomy of the Horse. Part ii. By John T. Share-Jones. Pp. xii+190. (London: Williams and Norgate, 1907.)

WHY do British veterinary anatomists adhere so tenaciously to a nomenclature which is absolutely indefensible? Many of the terms at present employed in the various English text-books on the anatomy of the domestic animals are admittedly unsatisfactory; yet British veterinary writers persist in their use, with the result that a Continental reader wishing to consult an English work is put to an infinity of profitless trouble. Not only are the English names incompatible with comparative anatomy; sometimes they are strikingly absurd. No more deplorable instance of misdirected ingenuity is to be found than in the names given to the three phalanges. The first phalanx rejoices in the name of "*os suffraginis*." Not only is this an unknown expression in scientific anatomy, it is also the outcome of error. Its inventor—possibly a French writer, be it said—completely mis-

took the meaning of the Latin word *suffrago* (*suffraginis*), which is generally defined as "the ham or hough of a quadruped's hind leg," and is used by Pliny and others as opposed to *armus*. If, then, an *os suffraginis* is to be recognised, it seems more reasonable to regard it as the femur. It certainly is not the first phalanx.

The second phalanx is known to the quasi-scientific veterinarian as the *os coronae*, a term which may be passed over by saying that the only defence for its use is the application by the stable-man of the name *coronet* to the region of the limb in which the bone is situated. To speak of the third phalanx as the *os pedis* is to subvert the meaning of the word *pes* as used in anatomy. The *pes* of the scientific anatomist includes the tarsal, metatarsal, and phalangeal regions of the posterior or pelvic limb; and has its parallel in the *manus* of the anterior or thoracic member.

In no part of the body are objectionable terms applied so frequently as in the limbs. This is doubtless due to the extreme degree of modification from the mammalian type which has been produced during the evolution of the modern horse, a modification so marked as to lead the original inventors of veterinary anatomical nomenclature to devise terms which to them seemed fitting, irrespective of their incompatibility with anatomical terminology in general. The time has come, however, when there is little excuse for aberrations. The BNA was devised with the intention that it should make the writings of an anatomist easily intelligible to his brother men of science. Works on anatomy, whether they be purely anatomical or partly surgical, should embody the universal nomenclature. If thought necessary, as is doubtless the case in books written largely for the practitioner, the customary English equivalents might be set down side by side with their Latin synonyms.

Mr. Share-Jones, in the volume before us, employs exclusively the undesirable names found in other English text-books, with the result that he cannot expect to appeal to a wider circle of readers than those who speak the English tongue. What exactly the aim of Mr. Share-Jones may be is difficult to determine. He certainly cannot claim to have produced a surgical anatomy, since he deals at some length with fractures and other traumatisms, diseases, symptoms, and even treatment. How far he was justified in including such subjects as "sore-shins," "breakdown," "speedy-cutting," &c., in a work entitled "*The Surgical Anatomy of the Horse*" is doubtful; but it is beyond question that microscopic structure is out of place in such a production.

Reputable books on anatomy—surgical or otherwise—are now produced with illustrations which may be termed artistic without doing violence to the English language. Indeed, the illustration of scientific works in general is now an art in itself. This being so, a work the value of which depends mainly upon its plates is apt to be judged by a fairly high standard. Most of Mr. Share-Jones's figures would not stand such a judgment. Apart from their execution, it is difficult to see why some of them are printed on so large a scale as to require quarto plates. It is, further,

not easy to decide on the value to the surgeon of large plates showing merely the bones of the shoulder and elbow joints, or figures of the various bones of the limb, or purely diagrammatic representations of the arterial arches and veins.

As the surgeon is well aware, veins are very much larger than the arteries they accompany. Figures of sections, therefore, should show this; and, in order that they may do so in a serviceable manner, should be made from formol-hardened bodies. Again, in the limbs, not infrequently two veins accompany an artery; and this is especially common in the region illustrated in plate ix. Figures of sections, furthermore, should be accompanied by some key to the precise level at which the cut has been made. In some regions, as, for example, about the carpus, a very small deviation in the level of two sections produces an appreciable difference in their appearance. The relationship of the vessels, &c., in plate xxi. may be correct, but where is the tendon of the flexor carpi radialis? Plate xxv., though semi-schematic, should show the slip passing from the tendon of the extensor communis to that of the extensor digiti minimi.

It is evident that the writer has been too ambitious, and has endeavoured to display encyclopedic knowledge in an utterly inadequate space. Consequently some subjects have had to be treated in a manner all too brief. A description of the nerve to the latissimus dorsi in three lines and two words, or of the subscapular nerve in two and a half lines, is of little value to the surgeon and none at all to the student.

The volume before us forms the second part of the complete work, and deals with the anterior limb. The printers and publishers are to be commended for their share of the work.

THE ROMANCE OF SAVAGE LIFE.

The Romance of Savage Life, describing the Life of Primitive Man, his Customs, Occupations, Language, Beliefs, Arts, Crafts, Adventures, Games, Sports, &c. By G. F. Scott Elliot. Pp. 384. (London: Seeley and Co., Ltd., 1908.) Price 5s.

A POPULAR yet accurate account of savage life would supply an obvious want; and though Mr. Scott Elliot's contribution is interesting and readable, it still leaves the field open to some more competent writer. The model for a book of the kind is the "Anthropology" of Prof. Tylor, a volume popular and at the same time truly scientific, with which Mr. Elliot does not seem to be acquainted. Like this it might dispense with a bibliography and footnotes. Mr. Elliot, however, professes to give references, but these and his list of authors are inadequate. If authorities are to be quoted full references should be given, and it is worse than useless merely to name without further detail books like Gibbon's "Decline and Fall" or the "Polynesian Researches" of Ellis.

A bibliography, again, which ignores Messrs. Spencer and Gillen and Dr. Howitt's last book on Australians; Col. Dalton, Sir J. G. Scott and Mr. Thurston on Indian forest tribes; Catlin and Schoolcraft on North American Indians; Dr. Rivers on the

Todas; Miss Kingsley and Col. Ellis on West Africa; Dr. Haddon's "Cambridge Expedition to Torres Straits"; the Journal of the Folk-lore Society; and last, but not least, the works of Dr. Frazer when totemism, death rites, and savage religion are discussed, is obviously of little value. The ethnographical chapters are naturally the best part of the book; but when the writer deals with the theory of the ghost as affecting methods of disposal of the corpse, with the belief in a future life, and with savage animism generally, he is evidently on unfamiliar ground.

It may seem hard to tax a popular writer with inaccuracies and omissions such as these. But if, as he might reasonably have done, he frankly declined to quote authorities, the case would have been different. When he professes to write in a scientific way he is bound by the laws which govern scientific work; and this is the more necessary in the case of anthropology, which claims to be an exact science. Finally, the time is past when a book like this can be illustrated by fancy drawings of prehistoric men attacking a beired mammoth, or of a young lady of the Swiss Lake-dwelling period doing up her back hair. It would have been much more instructive to supply photographs of modern savages at home, of the horses of La Madelaine Cave, or the man and bison from Laugerie Basse.

Even with all these drawbacks the book is a readable contribution to the excellent series of which it forms a part. Mr. Scott Elliot, without any pretensions to style, writes pleasantly, and though his personal experience of wild men seems to be confined to a part of Africa and Madagascar, he possesses a sufficiently vivid imagination to grasp the relation of the savage to his environment. From a comparison of their mode of life with that of Fuegians and Tasmanians, he is able to give a vivid sketch of life in the Cro-Magnon and Lake-dwelling periods, and his accounts of savage war and weapons, boats and huts, cookery and dancing, are often well done. The book will supply excellent reading to an intelligent boy, and may lead him to study the scientific literature of the subject.

OUR BOOK SHELF.

Die Vegetation der Erde. VII., Die Pflanzenwelt von West Australien südlich des Wendekreises. By Dr. L. Diels. Pp. xii+413. (Leipzig: W. Engelmann, 1906.)

THE Australian flora is of extraordinary interest, not only by reason of the complex problems connected with its origin and development, but also on account of the wonderful range of adaptation to their environment displayed by so many of its constituent species. It is with special pleasure, then, that we welcome the appearance of Dr. Diels's treatise on the flora of the south-western part of the continent. The method of treatment pursued by the author is a good one. He gives a fairly full historical account of the investigations of his predecessors, and incidentally criticises the "Flora Australensis," in common with other colonial floras, on account of the frequently insufficient data as to locality of a species. It must, however, be remembered that much of the material for these floras is collected through channels which

would render it impossible to furnish such data, and it is better to have the description of the plants, even if their habitats cannot be ascertained from the collectors.

The author, who spent many months going over the ground himself, gives a very good account of the physical and chief geological features of the country, and then discusses the general character of the flora, its chief geographical subdivisions, the latter of course depending on the amount and on the periodic distribution of the annual rainfall, and he then touches on the ecological side of the vegetation, and finally gives his views as to the relationship of the south-west Australian flora to that of the rest of the continent and thence to those of other lands.

He divides the flora into eastern, Eremæan (including the central regions), and western provinces. Of these, the eastern shows strongest affinities with the plants of other lands, e.g. with Indomalayan on the north and Antarctic in the south; whilst the Eremæan, though largely peculiar, yet betrays north-eastern relationship. The south-western region is far the smallest region, and also is the most peculiar. Dr. Diels considers, in opposition to the views advanced by some other writers, e.g. A. R. Wallace, that the flora of this region is a derived and specialised one rather than the starting point whence the typically Australian plants have arisen and spread over the rest of the continent.

It is impossible in a notice of reasonable length to deal at all fully with the contents of the book. It is one that should interest not only botanists, but all who can appreciate the bearing of plant distribution on geographical problems. The illustrations are good and the sketch-maps useful, though, perhaps, the inclusion of a general map in the volume might have rendered them more convenient for purposes of reference.

Das inneralpine Becken der Umgebung von Wien.

By Dr. Franz X. Schaffer. Pp. viii+128. (Berlin: Gebrüder Borntraeger, 1907.) Price 2.40 marks.

This little work, truly a book for the pocket, is one of the latest additions to Borntraeger's "Sammlung geologischer Führer." It guides the pedestrian to the excavations in the flat land close to Vienna, and shows how the sections in sands and marls illustrate the later phases of the struggle of central Europe against the old Mediterranean Sea. The history of successive marine invasions, penetrating the hollows of the rising mountain-chains, is well and succinctly expressed in three pages (pp. 7-9) quoted from the author's "Geologie von Wien." The Vienna basin results from the falling in of the area after the Middle Miocene uplifts and foldings. The south-eastern European sea then invaded it for the last time (p. 117), depositing in a gulf the marine Leithakalk, with a fauna partly tropical, and ultimately the Sarmatian and Pontic strata, which show increasingly brackish-water conditions. The boundary of the sunken area is still marked by hot springs and outflows of mineral waters, those of Baden occurring where the western margin of the basin is crossed by dislocations that follow the strike of the limestone Alps (p. 121).

The Vienna basin has a charm of its own, and a scientific visitor may well spend a few days in it with this little volume as his companion. He should, of course, also read the story of the larger area around the city in the monumental "Bild und Bau Oesterreichs" (see NATURE, vol. Ixx., p. 49), which is not a book that anyone could possibly carry in the field. We can soon escape from the noise of the very ill-planned suburbs, and at Schwechat are out along the quiet reaches of the Danube, making perhaps for the

purple "horst" of Hainburg, where the towers still climb up the rock, as a memory of invasion from the east. Or we go south along the main "Bruchlinie," under sombre wooded hills, until we penetrate the Alpine zone at Gloggnitz; or south-east across the Goldene Lacke, where the great Hungarian cattle plough the plain, which spreads here, as the result of subsidence, close against the mountain-spurs. The Leithagebirge that rises gently in the south actually lies in Hungary; and the line of Miocene fracture may still be perceived, when we attempt to carry the German language into the Slav and Magyar villages beyond it.

The British Journal Photographic Almanac and Photographer's Daily Companion for 1908. Edited by George E. Brown. Forty-seventh year. (London: Henry Greenwood and Co., n.d.) Price 1s. net.

This is the forty-seventh issue of an indispensable publication. Year by year the volume makes its appearance, and on each occasion it is found to contain just that collection of photographic matter which is so useful and valuable to the everyday photographer.

The arrangement of the material is on similar lines to that of its immediate predecessors, but we are glad to see that all indices to advertisers, text, &c., are placed together at the end of the volume, undoubtedly the proper place for easy reference.

Naturally, the new Lumière colour process of photography, the chief topic of the year and a wonderful advance in colour photography, is referred to at some length, and this by the editor, who includes it under the heading "Screen-plate Processes of Colour Photography."

The section entitled "Epitome of Progress" will be found as useful as ever, summarising as it does in abstracts, papers, communications, articles, &c., which have appeared in either home or foreign journals, adding—and this is a valuable feature—the full reference.

In "Recent Novelties in Apparatus" we have a very useful section. The editor only describes those articles which have come under his own personal examination, and only those introduced since the last issue of the almanac.

The approved formulæ, tables of chemical and optical data, lists of photographic societies, &c., have all been brought carefully up to date, and the mass of advertisements is, as usual, an important feature of the publication.

In addition to numerous illustrations, the frontispiece is an example of the autotype carbon tissues, 25,000 copies of which were printed by the Autotype Co., and mounted by the Adhesive Dry Mounting Co., Ltd., on paper provided by Messrs. R. T. Tanner and Co. An excellent coloured plate is reproduced by the Sanger Shepherd Colour-printing Syndicate, while another coloured plate is shown, the three-colour blocks and printing of which are the work of Messrs. Hood and Co., Ltd.

It may be stated in conclusion that the volume is a marvellously cheap shillingsworth, and will no doubt find its usual place on the shelf of every photographer's work-room.

Science of Nature-History. By Nasarvanji Jivanji Readymoney. Pp. 103. (London: Times of India Office, 1907.) Price 4s.

THE author provides what he describes as "A guide showing how or where to think on events or collect facts in nature-history order so as to describe and define events from nature-history point of view." It will serve to define the author's object if some of his technicalities are explained. Nature-history is a short, less luminous name for the practical study

of nature. To record an event according to nature-history is to fix its place in nature; and to assist the student in his record a series of skeleton classificatory schemes is provided. These tabular statements contain many terms new to orthodox science, and serve to illustrate the compiler's predilection for classification.

Nietzsche in Outline and Aphorism. By A. R. Orage. Pp. viii+188. (Edinburgh and London: T. N. Foulis, 1907.) Price 2s. 6d. net.

AFTER a short introduction dealing with Nietzsche's works, a few pages of "definitions" and a sketch of the philosophy formulated by the champion of nihilism, the compiler brings together a series of his author's aphorisms classified under such headings as "Philosophers and Philosophy," "Morality," and so on. As indicative of the searching character of the maxims, one may be quoted from each of the sections mentioned:—"The doer alone learneth"; "Education ruins the exception for the sake of the rule."

LETTERS TO THE EDITOR.

[The Editor does not hold himself responsible for opinions expressed by his correspondents. Neither can he undertake to return, or to correspond with the writers of, rejected manuscripts intended for this or any other part of NATURE. No notice is taken of anonymous communications.]

The Photoelectric Property of Selenium.

I HAVE lately constructed small seleno-aluminium bridges for the electrical measurement of starlight, and it occurred to me to put these bridges into a vacuum to see whether their sensitiveness to light is thereby increased or diminished. One of them, formed, of course, with conducting selenium, had a resistance of 61×10^9 ohms in air and great sensitiveness to light. It was placed in a glass tube connected with an air-pump. About twelve hours after the tube was exhausted to a pressure of about 0.01 mm., the resistance of the bridge had dropped to 61 ohms! From this it fell gradually, and it has now (three days after exhaustion) a resistance of 17.5 ohms.

I conclude, after repeating the result with three bridges, that conducting selenium when placed in vacuo drops in resistance about four million times, and possibly still more. Also it loses completely its sensitiveness to light.

Other things connected with this strange result are under investigation. I use the term "bridge," in preference to "cell" or "resistance," at the suggestion of Dr. A. A. Rambaut. These bridges are far more simple and easily used with a telescope than the "cells" which I used in the observatory of Dr. W. E. Wilson in Westmeath. The selenium employed was specially purified by Prof. Threlfall, who very kindly gave me a supply.

GEORGE M. MINCHIN.

The Electrical Laboratory, Oxford, December 21.

Early Chinese Description of the Leaf-Insects.

"YUEN-KIEN-LUI-HAN," a Chinese encyclopaedia compiled in 1703, tom. cxdlvi., fol. 9, b, has the following quotation from the "Tau-hwang-tshah-luh," written c. ninth century: "In Nan-hai a peculiar manner of bees (or wasps) live on the *kan-lan* tree (*Canarium pimela* or *C. album*). They look as if this tree's leaves were grown with hands and legs, wherewith to grasp branches and so deftly address themselves thereto that they are quite indistinguishable from the foliage. Therefore, to collect them the southern people used to fell the tree first and await the withering and falling of its leaves; and only then they are enabled to discern and gather the insects, which they employ as philer."

Nan-hai, literally "Southern Sea," was anciently the appellation of a province, the present Kwang-tung, but sometimes it was applied to the Indian Archipelago (Bretschneider, "Botanicon Sinicum," part iii., p. 579).

But for specifying them as bees or wasps, this Chinese account of the mimetic articulate would appear fairly to tally with that of the leaf-insects (Phyllium). Probably it is a very early, if not the earliest, description of these Orthoptera.

KUMAGASU MINAKATA.

Tanabe, Kii, Japan, November 14.

NO. 1991, VOL. 77]

THE SALMON.¹

WE have no hesitation whatever in advising all persons interested in the salmon, whether as fishermen, naturalists, or legislators, to add this book to their libraries. The blue and grey covers of the official reports of the Scotch Fishery Board and the Irish Department of Agriculture contain a great deal of most valuable information bearing upon the life and habits of the salmon, and, so far as Scotland is concerned, Mr. Calderwood has now collected into the book under review the information spread over a series of reports. In the case of Ireland the reports of salmon-marking experiments are now published separately in pamphlet form, and deserve a far wider circulation than they possess.

Mr. Calderwood, who think wisely, confines his book almost exclusively to the life-history of salmon in Scotch waters, but is careful to direct attention to points in which the habits of the same fish in some or all Irish rivers appear to differ in points of detail. He would have us, in the first place, regard the salmon as essentially a marine fish, and in this he may be right, though we see no real reason why an anadromous species need be definitely relegated to the category of either fresh-water or marine forms. We are, however, quite in agreement with his view that the Salmonidae are derived from originally marine ancestors, and would even hazard the suggestion that the presumably herring-like stock from which the Salmonids and Alepocephalids are derived may have been driven in the struggle for existence either to adopt an anadromous life or fresh-water habitat (as in *Osmerus*, *Salmo*, *Thymallus*, and *Coregonus*), or to retire into the deep sea like the Alepocephalids, *Argentina*, *Microstoma*, and *Bathylagus* found off our own coasts.

We must, in any case, look upon the salmon as a fish growing and feeding in the sea, resorting to fresh waters when feeding ceases on the approach of the spawning season, and spending the early part of its life near the place of its birth until strong enough to venture seawards; this is the standpoint from which we must regard and seek to explain the known phenomena of its life-history.

It is now more than forty years since the discovery was made that the first two years of the salmon's life are normally spent in the parr stage, while a few parr may move seawards in the first year and a certain proportion may spend three years in fresh water. Mr. Calderwood attributes this discovery to the Stormont-field investigations, but we fancy he is so far in error here that the percentages he quotes were really derived from Dunbar's Thurso experiences, communicated by him to Archibald Young when Commissioner of Scotch Salmon Fisheries.

At a length (in the Tay) of five or six inches, the parr assumes the silvery livery of the smolt, and passes seawards, in Scotland, so far as observed, always in spring. The second late summer or early autumn migration of smolts, noted annually in some Irish rivers, and intermittently in others, has not yet been observed in Scotland, and accordingly is not here dealt with.

On reaching the sea the smolt for a time eludes the ken of man, or, at all events, all fishing gear ordinarily employed by him, until it reappears as a grilse. This, hitherto little known, period of the fish's history is admirably handled by Mr. Calderwood. The few British and Irish records of young salmon between the lengths of six inches and two feet are carefully examined, and Dahl's Norwegian researches are cited

¹ "The Life of the Salmon; with Reference more especially to the Fish in Scotland." By W. L. Calderwood. Pp. xxiv+162. (London: Edward Arnold, 1907.) Price 7s. 6d. net.

to show that this period is normally spent in offshore waters, as occasional captures in mackerel nets would suggest. The marking of Tay smolts and control observations of the rings upon the scales of grilse have now shown that the first fish re-appear in the estuaries as grilse twelve to fifteen months after leaving the river as smolts, and that some fish may spend a further summer in the sea before seeking fresh water, then to re-appear as small spring fish. It would, however, be premature to assume that no fish re-ascend in the year of their descent as smolts.

This observation leads us naturally to the second essential fact of a salmon's life-history, that of the distinction between the "short migration" and the "long migration"; that is between the fish which return to fresh water in the summer or as spawners in the autumn or winter of the year of descent as kelts, and those which spend a longer period in the sea and return as clean fish early in the following spring. The difference may be well illustrated by the

admit? The unfortunate sacrifice of the Lismore Weir marking experiments to the objections of certain anglers has undoubtedly deprived us of an opportunity of reaching some conclusion upon this most important point; so far as the experiment went it certainly pointed to such fish not remaining in the Blackwater until the following spawning season, but dropping back to the estuary before ascending to the redds. Mr. Calderwood, in former papers, has adduced evidence of what he terms a "pausing habit" of winter clean fish in the lower waters of the Spey, but he now states that "in Scotland we have not evidence that clean fish are in any sense temporary visitors to fresh water or habitually drop back into the sea." He moreover notes that the spring fish entering the Ness have already reached the Garry by early in February, while the Tay fish are not found above Loch Tay until May or later. This question is closely connected with the further one, why are some rivers early rivers and some late rivers? To the latter ques-



A male salmon in full spawning livery, fresh from the sea in November. The fish has just been marked on the dorsal fin before its return to the river Tay at Almondmouth. From "The Life of the Salmon."

cases of two Irish fish of the same sex (female), weight (5 lb.) and length (2 feet 1 inch), marked as slats on the same day, January 18, 1902, and at the same place, one of which was re-captured on July 22, 1902, weighing 11 lb. and 2 feet 5 inches long, while the other was re-captured on June 16, 1903, weighing 18 lb. and 2 feet 11 inches long. It is possible that in some cases the "long migration" period may extend over two years, and it by no means follows that any individual fish is either always a short-period fish or always a long-period fish. A remarkable fact shown by results published up to date is the preponderance of short-period fish in Ireland and of long-period fish in Scotland.

Another problem is raised by the winter and spring fish of some rivers; do such fish merely ascend a short distance and then drop back again to the tide-way for further feeding before finally running to spawn, or do they ascend to the head-waters of the river they enter so soon as the physical conditions

tion Mr. Calderwood devotes considerable space, and his remarks, whether accepted as providing an answer or not, are well worthy of attention.

We can but briefly allude to many other points of interest touched upon by this book, such as the causes prompting a salmon to seek fresh water, the effects of temperature on a run of fish, and the question of fish "changing rivers."

Of the salmon's life in the sea until it comes coastward we can but assume at present that it is spent in pursuit of the shoals of herring or mackerel, while noting that the drift-net fishery for salmon off the west and north-west coasts of Ireland is conducted in late spring and early summer, sometimes as much as ten miles from the coast.

We reproduce an illustration showing a November fresh-run male salmon in full spawning livery, photographed before its return to the Tay after marking; the silver marking plate is seen on the dorsal fin. The Irish marks are similar in form and similarly

affixed, but oxidised in place of being left bright. Recently a new mark has been introduced in Ireland, consisting of a small numbered tag attached to the base of the dorsal fin by means of a ring; marks of this pattern are made of various size to suit any fish from a smolt upwards.

ENTOMOLOGY FOR THE YOUNG.

THIS book is not a scientific treatise; it is intended, as the author tells us in the preface, "to encourage the intelligent life-study of insects by our younger folk, to discourage collecting, and to stimulate the profitable employment of one's eyes and ears in town or country." This object is a very estimable one, and the author has done much to produce a book admirably adapted for this purpose.

It is divided into seven chapters, each containing many stories of insect life. The general introduction



Green-veined White Butterfly resting. From "The Story of Insect Life."

deals with all manner of subjects in a clear and very simple way, such as structure, eggs, metamorphosis, fertilisation of plants, the story of the wild drum, resemblance of plants to insects, &c. Then follows a chapter on beetles, some of our common forms being simply described. Earwigs, cockroaches, crickets, and grasshoppers form the theme of chapter iii., and dragon-flies, May-flies, &c., that of chapter iv. Now and again the author, unfortunately, pounces on scientific names. For many reasons, in a book for young people, these are best left out, particularly if wrong ones are used, as on p. 104, where the steel-blue wood wasp (*Sirex juvenicus*) is called *Sirex noctilo*!

Some of the stories form delightful reading, such as the story of the hive bee, p. 207.

Seventy-six pages are devoted to butterflies and

¹ "The Story of Insect Life." By W. P. Westell. [p. 339; illustrated. (London: Robert Culley, n.d.) Price 5s. net.

moths, and then the final chapter gives a few brief notes on bugs, frog-hoppers, gnats, and other flies that may attract the young person's attention.

The illustrations from photographs are mostly excellent, and some beautiful pictures are reproduced of localities where water insects abound. The author, unfortunately, in one has made a grievous error, for in Fig. 119 he gives the head of a male mosquito, *Theobaldia annulata*, as that of a female gnat, and refers to this in the text. For the young we should be just as careful to be accurate as for people more matured.

The eggs of the vapourer moth are not in a natural position in Fig. 17, and, again, a badly set and damaged tortoiseshell butterfly is clumsily stuck on an iris blossom (Fig. 86) in a very unnatural way. There are also many entomological errors.

The plates will be sure to attract the young mind, and they are excellently reproduced, but the artist appears to have a quaint idea of some of the insects, such as the blow-fly on plate viii., and also the water boatman. In spite of such faults, the book is one that may be recommended to all young folk, as it not only supplies a want, but fills that want in a clear and pleasant style.

FRED. V. THEOBALD.

LORD KELVIN.

IN NATURE for September 7, 1876, there was published, with the engraved portrait by Jeans, in the series of "Scientific Worthies," an account of Lord Kelvin, then Sir William Thomson, and of the scientific work, extending then over more than thirty years, by which he had rendered himself illustrious in physical science. Thirty-one years have elapsed since that appreciation was written, and now we have to mourn that this life of wonderful activity has come to its natural close. At the ripe age of eighty-three, as full of honours as of years, Lord Kelvin has passed away. To say that his eye was not dimmed, nor his natural force abated, would be scarcely strictly true, yet he retained to the last the exercise of his intellectual powers. The vigour and keenness with which he entered into the discussions at the British Association meeting at Leicester in August last were truly remarkable at his advanced age. It was in the course of making experiments in a corridor in his country house, Netherhall, Largs, that he contracted the chill which brought about the fatal end.

The article of 1876 gave in some detail those scientific achievements which had then made him famous; and a glance at its contents will show in brief what these were. While still an undergraduate at Cambridge, he had made valuable mathematical investigations in relation to Fourier's theorems, and in their applications to the motion of heat and to hydrodynamics. In these investigations will be discovered the foundation of the method of evaluating geological dates from underground temperatures upon which subsequently he built his famous conclusions as to the age of the earth. In the years which followed, during his early occupancy of the chair of natural philosophy at Glasgow, Lord Kelvin was largely occupied, in constant association with Joule, with the development of thermodynamics, to which not his least contribution was the theory of the dissipation of energy. This was followed by investigations into electrostatics and the theory of magnetism, contact electricity, thermoelectricity, the mechanical energies of the solar system, the calculation of the tides, the size of atoms, and vortex motion. That which, however, directed popular attention to his scientific attainments was not so much these deep investigations as his connection with the more practical problems of ocean telegraphy. The pos-

sibility of an Atlantic cable was in the early 'fifties a much-discussed question; and the mathematical investigation which Lord Kelvin made of the conditions governing the propagation of signals in long submarine cables proved to be the most important contribution to the practical solution of that problem. He showed that the retardation must be proportional to the square of the length of the cable; and, further, he applied the theorems of Fourier to predict the degree of attenuation of the impulses on their arrival at the distant end. This was followed by the invention of the mirror galvanometer, and later by the siphon recorder, with both of which instruments his name will ever be associated. The final success of the Atlantic cables of 1865 and 1866 was a triumph for his inventive ingenuity no less than for his mathematical skill and insight. He had likewise been brought intimately into nautical matters, leading him to devise the method of taking flying soundings, and to publish a set of tables for facilitating the use of Sumner's method at sea. To heighten his public fame he also re-modelled the mariner's compass by radical improvements which quickly established its superiority to all earlier forms.

All this was duly recounted in the article of 1876, and might well suffice to place him in the very first rank of physicists had he achieved nothing more. Von Helmholtz, summing up his intellectual attainments at that date, had remarked upon his method of treating the problems of mathematical physics how he had "striven with great consistency to purify mathematical theory from hypothetical assumptions which were not a pure experience of facts." He maintained that "the gift to translate real facts into mathematical equations, and *vice versa*, is by far more rare than that to find the solution of a given mathematical problem"; adding, "And in this direction Sir William Thomson is most eminent and original." Happily for science this gift continued to be exercised for thirty years after von Helmholtz penned this appreciation of his friend. As the years went on Lord Kelvin continued with marvellous activity of mind and body to add to his long list of scientific labours.

It has been noted above at how early a date, namely, in 1842, Lord Kelvin had published the germ of his theories about the age of the earth. This was in a paper on the linear motion of heat which appeared in the *Cambridge and Dublin Mathematical Journal*. This same subject he had made the topic of his inaugural lecture in 1846 on taking up his professorship at Glasgow. He returned to it in 1876 as the theme of his address as president of the Physical and Mathematical Section of the British Association at Glasgow. To the geologists who demanded unlimited time for the operation of these formative actions, which, on the abandonment of catastrophic notions, they had assumed to proceed with constant uniformity, Lord Kelvin announced with the utmost confidence that they must hurry up their phenomena, since the age of the earth as a habitable planet, so far from being unlimited, could not possibly exceed four hundred millions of years, and was more probably within twenty millions of years. The proposition was supported by several converging lines of argument. The surface temperature could not be what it was, considering the average conductivity of rocks and the gradient of temperatures found underground, if the cooling process had proceeded from an unlimitedly long anterior date. The heat of the sun itself must be constantly dissipated, and its temperature sinks; and with the cooling of the sun the earth also cools. Its form, in relation to centrifugal forces, was incompatible with the hypothesis of an unlimited time since it was a fluid mass. The controversy which arose, as

the biologists and geologists endeavoured to combat these arguments, lasted for a quarter of a century; and the end is indeed not yet.

Hydrodynamics is a branch of natural philosophy in which the Cambridge school under Stokes has always been strong; and Lord Kelvin, as a pupil and friend of Stokes, worked much at it. Hydrodynamics was indeed continually in Lord Kelvin's thoughts. His brilliant speculation of the vortex-atom remains—if we are to except recent electric theories of matter—the one and only hypothesis of the ultimate structure of matter that has yet been found to hold its own against destructive criticism. It has not yet been shown to be impossible or self-contradictory. Apart from this, his other investigations into hydrodynamics have been most fruitful. He discussed the conditions of stability of fluid motion in a large number of cases, some of them of practical importance. Within the past two years he contributed to the Royal Society of Edinburgh a series of papers on deep sea waves, papers which are full of characteristic applications of Fourier's theorems, and show unabated keenness in following out an intricate analysis. In elasticity and the kindred problems of dynamics, the influence of the master's hand is no less evident. The article which he contributed to the "Encyclopædia Britannica" on elasticity will remain a classic of science for many years. Those who are intimate with Lord Kelvin's work generally will know how much in this article there is that lies behind his other studies. His continual reference to the analogies which he found between the phenomena of magnetism and of electricity and those of elastic solids shows the working of his mind, and the fundamental views which he held on elasticity dominate alike his Baltimore lectures of 1884 and the papers on molecular physics of his latest years.

To the science of electricity, Lord Kelvin's contributions have been no less notable. Imbued with admiration for Faraday's experimental work, Lord Kelvin early set himself to ascertain whether the phenomena of electromagnetism can be explained on an elastic solid theory. Although it was left to Maxwell to carry to fruition this part of the subject, it was Kelvin's merit to have first applied mathematical analysis to the facts revealed by Faraday's researches. It was in 1847 that he first proposed a mechanical representation of magnetic force; and to this subject he returned in 1860, in an article first published in the third volume of his collected mathematical and physical papers. It was in the early days, too, that he investigated the conditions of the discharge of a Leyden jar in circuits possessing self-induction, predicting mathematically the fact that under certain conditions these discharges would be found to consist of electric oscillations. This discovery was published in 1853. Later, Feddersen and others observed these oscillations experimentally; and in the 'eighties this abstract research of Lord Kelvin's became the starting point of the investigations of Sir Oliver Lodge and of the lamented Heinrich Hertz, leading directly to wireless telegraphy.

In 1851 Lord Kelvin, impelled by the characteristic precision of his scientific character, and urged by the needs of exact measurement in telegraphy, had already adopted the absolute system of measurement initiated by Gauss, and extended by Weber. In Lord Kelvin's hands the absolute system of measurement, and with it the adoption of the metric system of standards, became almost an article of creed. In season and out of season he urged the superiority of the decimal measures over the ordinary British ones; and, consistently, he strove to bring all scientific measurements into terms of the fundamental metric

units of length, mass and time. Moreover, toward the end of the 'fifties, electric measurement, in the hands of the cable engineers, had become much developed, and instruments of a precision exceeding anything known then in the physical laboratory had been devised for practical use. In 1861 Lord Kelvin secured the appointment by the British Association of a committee on electrical standards, a committee of which also Wheatstone, Matthiessen, Fleeming Jenkin, and, later, Siemens, Clerk Maxwell, Joule, and Carey-Foster were members. Year after year this committee, with younger men added, has produced its reports with little intermission, and the system of units which it evolved is practically that which is internationally recognised and of legal force. Twice Lord Kelvin gave public expositions of the system in set addresses, at a South Kensington conference in 1876, and before the Civil Engineers in 1883. The latter of these discourses is in Lord Kelvin's most characteristic style, and even now, after twenty years, some of it is hard reading for any but a professed physicist. But mere hardness never daunted Lord Kelvin. In the same lecture, speaking of a particular point in the system of absolute measurement, he said:—"It may be hard to accept, but the harder it is the more it is worth thinking of." The acceptance and rapid development of the international system, based on the centimetre, the gram, and the second, is due to Lord Kelvin more than to any other man.

After the adoption of the new units by the International Congress at Paris in 1881, Lord Kelvin devoted much attention to the production of commercial instruments for the measurement of current, potential, and electric power. Relying confidently on the rightness of abstract principles, he produced a series of ampere-balances for currents of different strengths, thus putting into the hands of practical engineers a set of instruments of remarkably great accuracy and of remarkable range. When occupied with the tides, in the 'seventies, he had devised a machine for analysing the harmonic components of the periodic tidal variations, the essential part of this harmonic analyser being a mechanical integrating device of globe, disc, and cylinder, first suggested by his brother, Prof. James Thomson. It seemed a bold thing to apply such mechanism to evaluate the integrals indicated by Fourier's analysis; but Kelvin's machine justified the hardihood of the conception. When in the 'eighties he had before him the problem of constructing an electricity meter which should continuously integrate the varying product of current and voltage of an electric supply, he again had recourse to the same integrating mechanism. And, here, it may be remarked in passing that it is to Lord Kelvin's evidence before the Parliamentary Committee in 1879 that we owe the circumstance that the Board of Trade adopted as its official unit of electric energy the value of one thousand volt-ampere-hours. It was once upon a time proposed to denominate this unit—now universally employed—by the name of one "kelvin." Lord Kelvin's innate modesty caused him to reject the suggestion. Surely the time has now come for the final incorporation of his name into the international system, thus linking it with those of Volta, Ampère, Ohm, Coulomb, Watt, Faraday, Joule, Henry, and Gauss.

Lord Kelvin had a peculiar predilection for illustrating recondite notions by models. He once said that he could never understand a thing until he could make (or conceive) a model of it. His chain of gyrostats to illustrate the rigidity of the ether, his systems of crystal models made of little wooden rods and balls held in stable equilibrium by india-rubber bands, are but two examples of a mode of using the concrete to realise the abstract that he practised continually. He

was fond of introducing into abstract dynamics terms derived from other sciences, geodesy, and crystallography. Amongst the bye-products of his genius may be found enshrined in the Proceedings of the Royal Society a short paper containing the essentials of the theory of the designing of wall-paper patterns; its title, however, is "The Homologous Partition of Space."

Of Lord Kelvin's later work on molecular physics, the "tactics of a crystal," the problems of æotropic elasticity in relation to optical as well as magnetic and electric phenomena, it is less easy to speak. The lectures which he gave at Baltimore in 1884 to "his twenty-one coefficients," the members of the group of accomplished physicists who then sat at his feet day after day, while he led them through the mazes of the elastic-solid theory and the newly-invented spring-shell molecule, remain a witness to his extraordinary fertility of intellectual resource. All his life he had been endeavouring to discover a rational mechanical explanation for the most recondite phenomena—the mysteries of magnetism, the marvels of electricity, the difficulties of crystallography, the contradictory properties of ether, the anomalies of optics. And during the preceding decade he had been confronted with a great generalisation which did not fit in with this method of intellectual apprehension, which had become to him instinctive. While Kelvin had been seeking to explain electricity and magnetism and light mechanically, or as mechanical properties, if not of matter, at least of ether, Maxwell had boldly propounded the electromagnetic theory of light, and had drawn all the younger men after him in acceptance of the generalisation that the waves. Lord Kelvin had never accepted Maxwell's theory. It is true that in 1888 he gave a nominal adhesion; but later withdrew it, preferring still to think of things in his own way. Kelvin's Baltimore lectures of 1884, abounding as they do in a host of brilliant and ingenious points, and ranging from the most recondite problems of optics to speculations on crystal rigidity and molecular dynamics, leave one with a sense of being a sort of protest of a man persuaded against his own instincts, and struggling to find new expression of his thoughts so as to retain his old ways of regarding the ultimate dynamics of physical nature. During the last few years of his life Lord Kelvin himself revised these lectures, enriching them with a variety of new materials, and coordinating the old. He was intensely interested in the new problems raised by the discovery of radium; and in its astonishing property of continuously emitting heat. He combated strenuously the hypothesis of Rutherford that this was to be explained by a spontaneous decomposition of the atom; and to the very last he was seeking for other explanations.

At the present time, when so much of the new knowledge is in a state of flux, it would be entirely premature to attempt to evaluate the ultimate importance of Lord Kelvin's later writings on radium and on the "electrons." Suffice it to say that he brought to bear on these things the same illuminating genius, the same keen analytical instincts, that he had shown throughout his long career.

To two generations, if not three, of scientific men his work, his presence, his mathematical genius, his enthusiastic faith in first principles, and his unflinching gentle courtesy have been an inspiration and a perpetual stimulus. So he rests from his labours, and his works do follow him. SILVANUS P. THOMPSON.

LORD KELVIN'S FUNERAL IN WESTMINSTER ABBEY.

The decision taken by the Dean of Westminster to accord to Lord Kelvin burial in Westminster Abbey met at once with a warm and responsive echo of satisfaction on the part of men of science and the com-

munity generally. In the Abbey he has joined a noble company of departed worthies—Newton, Herschel, Lyell, Spottiswoode, Darwin—names that perpetuate some of the most glorious and imperishable achievements in natural knowledge. Especially gratifying must it be to the Royal Society to feel that the remains of their illustrious past-president find a resting-place side by side with those of Sir Isaac Newton.

The representative gathering that filled the Abbey on Monday, December 23, afforded ample testimony to the wide and varied interests, apart from pure science, that dominated the career of Lord Kelvin. Not only a brilliant moving figure in the hierarchy of science, he was also a great citizen, ever mindful of the best traditions of English public life.

The funeral service, which commenced at noon, was of the most impressive character. The King was represented by His Grace the Duke of Argyll, K.G.; the Prince of Wales by Lt.-Col. Sir Arthur Bigge, G.C.V.O.; and the Duke of Connaught by Major L. Green-Wilkinson. The Princess Louise (Duchess of Argyll) was present, attended by a lady and gentleman in waiting. Seats in the choir stalls were occupied by:—

Lady Rayleigh, the Russian and Italian Ambassadors, Mr. J. Ridgely Carter, representing the American Ambassador; Baron von Stumm, representing the German Ambassador; and Mr. Ijūin, representing the Japanese Ambassador; the Lord Mayor of London (who was robed), and the Master of the Clothworkers' Company. The First Lord of the Admiralty, Lord Tweedmouth, accompanied by his secretaries, attended to represent the Board of Admiralty. The Lord President of the Council was represented by Mr. Almeric FitzRoy.

At the Chapter House a procession was formed, which, headed by the choir and officiating clergy, slowly wended its way from the Chapel of St. Faith through the cloisters, and, while the hymn "Brief life is here our portion" was being sung, to the nave, and thence to the lantern, beneath which the coffin was temporarily deposited. The order was as follows:—

Clergy and choir; bier; pall bearers; chief mourners; Institute of France, M. G. Lippmann, For.Mem.R.S., M. Henri Becquerel, in addition to M. Darboux, For.Mem.R.S., perpetual secretary, who took part as a pall bearer; Lord Mayor of London; Master of Clothworkers' Company; the Royal Society; the Royal Society of Edinburgh and other British and foreign learned societies; Universities of Cambridge and Oxford; University of Glasgow and other Glasgow delegations; University of Edinburgh and Corporation of Edinburgh; other British universities.

A guard of honour of the Electrical Engineer Volunteers, of which Lord Kelvin was Colonel-in-Chief, lined the cloisters, Colonel R. E. B. Crompton, C.B., commanding. The guard fell in at the end of the procession, and took up a position in the nave.

The pall bearers and chief mourners were as subjoined:—

Pall Bearers.

Lord Rayleigh, O.M. (President of the Royal Society).	Sir Edward H. Seymour, O.M. (Admiral of the Fleet).
Mr. J. Morley, O.M. (Secretary of State for India).	M. Gaston Darboux, For.Mem.R.S. (Perpetual Secretary of the Paris Academy of Sciences).
Sir Archibald Geikie, K.C.B., Sec.R.S. (President of the Geological Society).	The Lord Strathcona and Mount Royal (High Commissioner for Canada).
Prof. A. Crum Brown, F.R.S. (Royal Society of Edinburgh).	Sir George Darwin, K.C.B., F.R.S. (University of Cambridge).
The Master of Peterhouse, Cambridge (Dr. A. W. Ward).	Dr. MacAlister (Principal of the University of Glasgow).
Sir J. Wolfe-Barry, K.C.B., F.R.S. (Institution of Civil Engineers).	Dr. R. T. Glazebrook, F.R.S. (Institution of Electrical Engineers).

Chief Mourners.

Dr. J. T. Bottomley, F.R.S.	Mr. James Thomson, Mr. W. Bottomley.
Mr. G. King.	Sir Alex. Brown.
Mr. W. Crum and two other nephews, Mr. D. King, Mr. J. F., Mr. W., and Mr. G. Bottomley.	four grand-nephews.

On the part of the Royal Society, in addition to pall bearers and other Fellows who also represented universities, there were present Mr. A. B. Kempe (treasurer), Prof. Larmor (secretary), Sir W. Crookes (vice-president), Sir J. Stirling, Sir John Evans, Major MacMahon, &c., and Mr. R. Harrison (assistant secretary).

It is unfortunately impossible to find space here to print the long list of representatives of British universities, scientific societies, and institutions present at the funeral, and we are only able now to state that the following foreign societies were represented in addition to the Paris Academy of Sciences already mentioned:—

Imperial Academy of Sciences of Vienna, Lord Rayleigh; Accademia dei Lincei, Rome, Sir Norman Lockyer, Prof. J. J. Thomson, Sir David Gill, and others; the Elektrotechnischer Verein of Berlin, Mr. A. Siemens; Società Italiana di Fisica, Associazione Elettrotecnica Italiana, and Phys. Verein Frankfurt a.M., Prof. Silvanus P. Thompson, &c.

NOTES.

We announce with deep regret the death of Dr. Janssen, director of the Meudon Astro-Physics Observatory, at eighty-three years of age.

A REUTER message from Copenhagen states that experiments made by the Amalgamated Radio-Telegraph Company of London and Copenhagen, owners of the Poulsen system of wireless telegraphy and telephony, show that wireless Poulsen telegrams between Newcastle and Copenhagen and Berlin and Copenhagen can be written directly from the receiver with ink as in the case of telegraphy by wire.

THE Royal Statistical Society's Guy medal in gold has been presented to Prof. F. Y. Edgeworth for his services to statistical science.

DR. THOMAS ANNANDALE, Regius professor of clinical surgery in the University of Edinburgh, died on December 20 at sixty-nine years of age.

ON Saturday next, December 28, Sir David Gill, K.C.B., F.R.S., will deliver the first of the annual course of juvenile lectures at the Royal Institution on "Astronomy, Old and New." The remaining lectures will be delivered on December 31, January 2, 4, 7, and 9.

MR. ELIHU THOMSON, writing from the General Electric Company, Lynn, Mass., U.S.A., comments upon the description of the exhibition of globe lightning in West Australia described in our issue for October 31 (vol. lxxvi., p. 671), and provides particulars of another case brought before his notice by a friend. The phenomenon referred to by Mr. Thomson is said to have appeared as a ball of yellow flame continuously in motion with a central nucleus rose-red in colour, and to have exhibited many points of similarity with the globular lightning seen in Australia on the occasion mentioned in our previous note. From Mr. Thomson's letter it is not clear whether the report made to him relates to globular lightning or to a fireball.

IN the report of the Bristol Museum and Art Gallery for 1907 the committee announces that the success of the combined institution during the period under review has been very pronounced, the total number of visitors considerably exceeding half a million. A new departure is the

installation in the museum of a section devoted to economic biology, galls and gall-flies, together with the various animal and vegetable pests infesting orchards and forests, forming the main exhibits at present before the public.

The luminiferous properties of the brittle-star, *Amphipura squamata*, and other echinoderms form the subject of an article by Irene Sterzinger in vol. lxxxviii, part iii., of *Zeitschrift für wissenschaftliche Zoologie*. The light is displayed at the summits, and not, as hitherto supposed, at the bases, of the "feet," where it emanates from slime secreted by the epithelium. There is, however, a luminiferous and a non-luminiferous slime. Similar slime-glands occur in certain other echinoderms. Both kinds of slime are soluble in hydrochloric acid.

We have received a copy of Bulletin No. 72 of the U.S. Entomological Bureau, in which Messrs. W. D. Hunter and W. A. Hooker record the results of investigations into the life-history of the North American fever-tick (*Margaropus annulatus*), and the best modes of keeping the species in check. In parts of Texas and some of the other southern States cattle-breeding is almost impossible owing to this pest, which is estimated to cause an annual loss of one hundred million dollars.

An important addition to the somewhat scanty literature of galvanising is made by Mr. Alfred Sang, who has published in the Proceedings of the Engineers' Society of Western Pennsylvania an elaborate monograph on old and new methods. The hot process of galvanising dates from Crauford's patent of 1839, and the origins of electro-galvanising, or cold galvanising, as it is often called, are also remote, but commercially it is a new process. In 1902 Mr. Sherard Cowper-Coles patented his process for galvanising metal goods by packing them in zinc dust in an air-tight retort, and heating the retort to a temperature below the melting point of zinc. This process is known as sherardising. The first attempt to coat metals by means of zinc vapour was made by Jean Pierre Chambeiron in 1864. Mr. Sang's investigations on the volatilisation of zinc from zinc dust at low temperatures have led him to important improvements in the vapour process, and there is every reason to hope that this method will soon take its place in the metal industries as a powerful antidote to corrosion. Undoubtedly the proper place to search for further improvements in protective coverings for iron and steel is in the study of the true causes of corrosion.

In the Bulletin of the Moscow Imperial Society of Naturalists for the year 1906, Prof. E. Leyst, director of the meteorological observatory of that place, contributes an important article on the estimation of the amount of cloud. The matter at first sight would appear to be one of the simplest of meteorological observations, but very few stations are so placed as to have a clear horizon, especially when situated in towns or in valleys. Prof. Leyst has submitted the Moscow observations for several years to a careful discussion, dividing the whole sky into three zones of 30° each. Taking the zenithal zone 60°-90° as the unit of comparison, he finds that in the lower zone the yearly mean of cloudiness is twice as great as in the zenithal zone, and that for the whole of the sky the yearly amount of cloud is 43 per cent. greater than in the zenithal zone, the amounts differing according to the season and to the time of observation. All things considered, the results seem to show that observations of amount of cloud in the zenithal zone are to be preferred; the author also considers that observers should be instructed how to divide the area under observation, so as to estimate cloud in tenths.

The physiology and habits—the "behaviour," as it is now the fashion to call these factors in the life-history—

of a common American starfish, *Asterias forrieri*, are discussed at considerable length by Mr. H. S. Jennings in a paper issued as one of the zoological publications of California University. The modes by which the creature manages to hold its own in the struggle for existence, the way in which it obtains its food, and kindred subjects, are in turn discussed, and the results of the investigation of all these factors will, it is hoped, afford an insight into the complex life of the sea-shore generally, and manifold inter-relations of the numerous organisms which make this zone their home.

IN VOL. xxi., art. 11, of the Journal of the College of Science of Tokyo University, Mr. S. Hatta concludes his account of the gastrulation of the ovum of the lamprey (Petromyzon). In the neighbourhood of Sapporo the species during the spring spawning season resorts in numbers to the streams, and thus affords abundant working material, which was developed by means of artificial fertilisation. The author considers that the ovum exhibits a kind of belated development, the blastulation and gastrulation stages overlapping one another, so that what should be the blastula appears to be really an old morula stage. The prime cause of this belated development is indisputably due to delay in segmentation, owing to the accumulation in the ovum of a great amount of yolk.

THE culture of marine fishes and crabs and lobsters in America, by Mr. G. M. Bowers, U.S. Commissioner of Fish and Fisheries, forms the subject of an illustrated article in the November number of the *National Geographic Magazine*. The United States, according to the author, is a long way ahead of any other nation in the matter of marine fish-culture, the only country coming anywhere near it in this respect being Norway, which was, indeed, the pioneer. This, in the author's opinion, is accounted for by the fact that in many countries it is believed to be an impossibility to make any marked increase in the numbers of sea-fishes by artificial culture, as it is seriously to diminish them by fishing. This, however, is far from being the view entertained by the Government of the United States; which carries on fish-culture, and crab and lobster propagation, to an enormous extent in species hatcheries and laboratories. The fishes regularly cultivated—by collecting and artificially fertilising the spawn—are cod, flounders, pollack, and, to a less degree, mackerel, bass, &c., while lobsters are reared at several stations, more especially the one recently established at Boothby Harbour. The general plan of operations is described very graphically by the author.

A MEMOIR by Mr. David Heron on the statistics of insanity and the inheritance of the insane diathesis has been issued by Messrs. Dulau and Co. for the Francis Galton Laboratory for National Eugenics, University of London. The material on which the memoir is based was provided by Dr. A. R. Urquhart, physician superintendent of the James Murray's Royal Asylum, Perth, and consisted of 331 family trees of asylum patients, giving very full details of the brothers and sisters, parents, and in some cases grandparents and children of the patient. The general results are very similar to those of the memoir, previously issued, by Prof. Karl Pearson on pulmonary tuberculosis. The inheritance of the insane diathesis is very marked, the correlation-coefficient between parent and offspring (as calculated by Prof. Pearson's method) lying between the values 0.52-0.62. The figures are bound to be somewhat uncertain, for they involve an estimate of the proportion of the inhabitants of Scotland who have been at any time certified as insane; the census and the Lunacy Commissioners' returns, of course, can only

give the number of patients at a given time or during a given period. Taking the figures for tainted stocks only (pedigrees of asylum patients), 21 per cent. of the offspring were insane when both parents were sane, 24 per cent. when one parent was insane, and 50 per cent. when both parents were insane, the last figure being, however, somewhat doubtful, as it is based on very few cases. There does not appear to be any lack of fertility in the tainted stocks, the mean size of family in 331 families containing at least one insane member being 5.97; eighty-seven matings in which one parent was insane gave a mean of 5.18 children, matings which were not necessarily completed.

MR. T. SHEPPARD, the curator of the Hull Museum, continues his useful work of issuing bulletins at the cost of one penny each, describing the collections under his charge. The most recent issues are devoted to "Notes on the more Important Discoveries in East Yorkshire," and to an account of a British chariot burial discovered during the present year at Hunmanby, in the same district. In the first pamphlet he has collected records of the most notable discoveries, adding useful references to the publications in which they are described. Many valuable relics have passed into other museums or into the hands of private collectors, while several have altogether disappeared. Now that a suitable building has been provided, the collections are rapidly increasing. The British chariot burial at Hunmanby presents many features of interest. The bottom of the grave was occupied by a great wooden shield, apparently of oak, ornamented with thin plates of bronze. The greater part of the woodwork was, unfortunately, destroyed in the landslide which directed attention to the interment. The bones were in a state of decay, but the recovery of two teeth of a horse indicates that the animal was buried with its master. Considerable portions of the chariot were recovered; and while in other Yorkshire burials of this class the bridle-bit is usually of iron coated with bronze, here it is of bronze throughout. The date of the interment is fixed in the first or second century B.C. In more than seven hundred early British burial mounds excavated by Canon Greenwell, Mr. Mortimer, and others, only about half-a-dozen chariot burials were discovered. The "find" at Hunmanby is thus of considerable archaeological importance.

THE first appendix to the *Kew Bulletin* for 1908, being the list of seeds of hardy herbaceous plants and of trees and shrubs available for exchange with botanic gardens and correspondents of Kew, has been received.

PROF. W. TRELEASE contributes to the annual report (No. 18) of the Missouri Botanical Garden a note on the genus *Yucca*, supplementing his monograph published in a former report (No. 13). Under the group of *Sarcococca* the author revises the species allied to *Yucca valida*, making a new species, *Yucca decipiens*, and indicates their distribution on a map. Characteristic illustrations of *Yucca periculosa*, and a new species, *Yucca Endlichiana*, are given. The latter, sent under the vernacular name of "pitilla," is said to yield good fibre; it is acaulescent, and bears very small, often dark, flowers.

AN account of the chemical examination, by Mr. E. A. Mann and Dr. W. H. Ince, of certain West Australian poison plants is published in the progress reports issued as two pamphlets by the Department of Agriculture for the colony. About fifty poisonous plants are said to occur in the State, of which several belonging to the genera *Gastrolobium* and *Oxylebium* are regarded as the most general sources of stock poisoning. One species of each of these

genera was examined, and from each a strongly toxic alkaloid was isolated. The authors also attempted to find an antidote; this, so far as experiments go, is furnished by a preparation of which permanganate of potash is the important constituent.

IN the course of investigations into the nature of Para rubber, Dr. D. Spence was led to examine the constituent, always present, that is insoluble in chloroform or similar solvents. Proceeding from the known occurrence of protein substances in the latex, he comes to the conclusion that the insoluble portion is a protein giving a strong xanthoproteic reaction, and comments on the peculiar fibrous structure shown markedly in sections stained with silver nitrate. This conclusion raises the practical question whether the presence of this insoluble constituent in the latex does not exercise an important physical function in the raw product. The paper is published by the Liverpool Institute of Commercial Research in the Tropics as journal reprint No. 13.

THE Journal of the Department of Agriculture of South Australia for October contains an account of the law relating to certain specified noxious weeds, with popular descriptions of them. Any landowner suffering these weeds to grow on his land, or on the adjoining roadsides, is liable to severe penalties. Should the District Council not enforce the law—and it appears this sometimes happens—the Commissioner of Crown Lands is authorised to have the weeds destroyed, and recover the cost from the council.

THE October numbers of the *Transvaal Agricultural Journal* and of the *Cape of Good Hope Agricultural Journal* have recently come to hand. The former contains an excellent article by Mr. F. B. Smith on agricultural education and research. Mr. Smith's department has been so successful in dealing with agricultural problems, and has appealed so strongly to the Boer farmer, that his plea for a sound and comprehensive system of agricultural education in the Transvaal is not likely to pass unheeded. There are also a number of articles dealing with practical farming matters, and some analyses of Transvaal fodder crops. The Cape of Good Hope has not the advantage of a large agricultural department, and its journal is consequently smaller. Some experiments are described by Prof. Duerden in which the rate of growth of ostrich feathers was found to be $1\frac{1}{2}$ inches per week.

WORCESTERSHIRE fruit growers suffer a great deal from the attacks of the apple sucker (*Psylla mali*), and arrangements were therefore made last year for Mr. Kenneth G. Furley, acting under the supervision of Mr. F. V. Theobald, to visit certain districts and carry out spraying experiments. The results are now issued as a report by the Worcestershire Education Committee. Very few eggs were found on the trees at the beginning of October, though the winged "Psylla" were flying about in great numbers; but about the middle of the month the eggs were thick on the trees, especially on the spurs. The dates of hatching varied; some came out on April 3, while others in the same orchard only appeared on April 10; the blossom and leaf buds were then attacked. Of the various washes tried, the most effective was the mixture of lime and salt recommended by Mr. Howard Chapman. The experiments were evidently well carried out, and the example of the Worcestershire Education Committee might well be followed by others. Considering the enormous losses caused to fruit and hop growers and gardeners generally by insect or fungoid pests, and the great amount of money spent on washes, it is surprising how little systematic work on the subject is done in England.

DR. C. M. LUXMOORE has sent us a copy of his final report on the analysis of one hundred soils from the county of Dorset, preliminary reports upon which, by Dr. Luxmoore himself and by Prof. Percival, have already been issued from the University College of Reading. The soils and their subsoils have been taken from typical localities situated upon all the formations, ranging from the Bagshot Sands to the Lower Lias, which are exposed in the county, and the report contains detailed analyses, both mechanical and chemical, together with certain determinations of their physical constants. In this latter connection one or two novel methods of examination have been proposed, designed to obtain some information as to the behaviour of the soils in the field. In addition to the analytical figures, the report contains a full discussion of the results, in which attempts are made to estimate the interdependence of some of the constituents and the extent to which they may be correlated with the properties of the soil. The report represents a very considerable piece of work, which has occupied Dr. Luxmoore for many years.

IN NATURE of December 27, 1906 (vol. lxxv, p. 197), attention was directed to the remarkable book by Dr. F. Oswald on the "Geology of Armenia." A second edition of this work is now promised; and the author has issued a large lithographed map of the country described, on which the geological features are coloured by hand. This map and an explanatory pamphlet are published by Messrs. Dulau and Co., London (25s. net), and should obviously be secured by those libraries that possess the original work of reference. The country dealt with includes, as a central feature, the great lacustrine and volcanic plain north of Lake Van, and its extent may be judged from the fact that the scale of the map is 1 inch to sixteen miles, and that the sheet measures 37½ inches by 21½ inches. In the pamphlet, which is in itself a guide to the geological structure of Armenia, the striking extent of the marine transgression in early Miocene times is emphasised, the present country being due to Middle Miocene folding, followed by fault-block movements during the Pliocene period.

The annual report of the State geologist of New Jersey for 1906 (Trenton, 1907) is a volume of 192 pages, containing, in addition to the administrative report for the year, valuable papers on building stones, on the glass-sand industry, on the Triassic copper ores, and on trap rocks for road construction. Mr. W. E. McCort has made some careful tests to determine the fire-resisting qualities of New Jersey building stones. The crystalline rocks at a temperature of 550° C. were not greatly affected. The gneisses cracked parallel to the banding, and, as a rule, it is safe to assume that a gneiss will be more damaged than a crystalline rock of the same texture and composition without the banding. Clay rocks suffered badly. The sandstones resisted fairly well, while the limestones seem to have suffered the least injury of all the stones tested. The paper by Messrs. H. B. Kümmel and R. B. Gage on the glass-sands of New Jersey shows that they contain more iron, and consequently obtain lower prices at the glass factories than do the Pennsylvania sands with which they compete. If the iron-bearing minerals could be removed by improved methods of washing, by magnetic separation, or by sieving, a grade of glass-sand superior to the best Pennsylvania sand would be obtained. Mr. J. Volney Lewis gives the results of his investigations of the petrography of the trap rocks and of the origin of the copper ores commonly found in proximity to them. The view put forward that the copper

ores are deposits from ascending magmatic waters expelled from the great intrusive mass in the vicinity appears to be well supported by facts. Lastly, a record is given of tests of the resisting qualities of the trap as determined by a series of experiments carried out in cooperation with the Department of Agriculture. As the trap rocks are extensively used for road metal, these tests of their wearing qualities should prove of value when considered with regard to the results already shown by actual use.

A COLOURED supplement to the December number of the *Quarry* conveys an admirable impression of the appearance of the green marble now being quarried on the island of Iona. The marble occurs in gneiss of pre-Cambrian age as a well-defined vein, and its beautiful green colour is due to the presence of serpentine derived from forsterite by hydration.

AN important contribution to the study of weathering phenomena in building stones is afforded by a paper by Mr. E. Kaiser on the Stuben sandstone of Württemberg in the *Neues Jahrbuch für Mineralogie* (1907, ii., pp. 42-64). This stone was largely used in 1842 to 1868 on Cologne Cathedral, and now exhibits marked disintegration, the weathered material showing an external layer of scale, and below it a layer of soluble calcium and magnesium sulphates. In the quarry, on the other hand, the weathering consists in solution of the calcium and magnesium constituents of the brown spar in the rock with deposition of the iron as hydrated ferric oxide. It is evident that the disintegration in Cologne is caused by sulphur derived from smoke gases.

A DETAILED account has been published by Mr. N. W. Lord (United States Geological Survey, Bulletin No. 323) of the experimental work conducted in the chemical laboratory of the United States fuel-testing plant, St. Louis, between January 1, 1905, and July 31, 1906. Interesting results have been obtained in the determinations of specific gravities of coal, in laboratory methods of determining the adaptability of coals to improvement by washing, and in the estimation of volatile matter in coals and lignites. It is shown that the value obtained for volatile matter in coal is affected by the method of heating the sample, by the fineness of pulverisation, and by the amount of loosely held moisture present.

THE question of the concentration of ores is one to which much attention has recently been devoted, and inventors have been busy in the new field of flotation processes in which the concentrate is removed from the top and the tailings from the bottom, apparently in contravention of the law of gravity. A new process invented by Mr. A. P. Macquisten, and successfully applied in the United States, is described in the *Engineer* of December 13. It is based on the utilisation of the surface tension of liquids, it having been found that sulphide ores possess some property that prevents them from becoming wetted, whilst gangue minerals do not possess this property, and readily sink. At the Adelaide mine, Nevada, the process has been applied to copper pyrites, iron pyrites, blende, and galena with heavy gangue minerals, the presence of which rendered ordinary methods of concentration ineffective.

We have received from Dr. Van Rijkvovorsel parts iii. and iv. of his laborious investigation entitled "Constantly Recurring Secondary Maxima and Minima in the Yearly Range of Meteorological Phenomena." For details as to the methods employed we would refer our readers to the

notice of part ii., relating to temperature (NATURE, vol. lxxiii., p. 594), where it is explained that the author claims that the observations over the whole earth, collectively, and in the northern and southern hemispheres, separately, show half-yearly and other periods the epochs of which are identical. Part iii. deals with barometric pressure, for which 2755 years of observations are used, but are necessarily very unevenly distributed, 2255 years being to the north of the tropics, and only 381 years to the south. The similarity between the curves for the north and south hemispheres is not so pronounced as in the case of the temperature curves, as the years available for the south are altogether insufficient for the purpose, but the author thinks that with sufficient materials the results would probably be nearly identical. The results with regard to rainfall are much less satisfactory; the elimination of disturbances caused by heavy downpours in thunderstorms requires a much longer period of observation than is at present available. The paper is accompanied by tables and curves showing the variations exhibited by both elements.

THE foundations of geometry form the subject of the presidential address to section iii. of the Royal Society of Canada, by Prof. Alfred Baker, published in the Transactions of the society, 1906-7. The author traces the history of the axiom of parallels from an anecdote about Lagrange, and from the early writings on the subject of Gauss, Bolyai, and Lobachevski, and he gives a detailed abstract of Hilbert's assumptions. Referring to an attempt made in 1570 by Sir Henry Savile, of Oxford, to stimulate interest in Greek geometry by explaining the first eight propositions of Euclid to a class of university students, and comparing this result with the performance of modern schoolboys, Prof. Baker thinks that a time may come when schoolboys will find no difficulty with the abstractions of Hilbert's geometry, and the truth of Prof. Halsted's claim may be felt that "geometry at last made rigorous is also thereby made more simple."

THE August Bulletin of the Bureau of Standards of Washington, contains a detailed comparison of the four most accurate methods of comparing the capacities of condensers, from the pen of Mr. F. W. Grover. He finds that the four are about equal in accuracy when the various sources of error inherent in each method are eliminated. He advocates the use of an auxiliary adjustable air condenser to enable comparisons to be made by the method of substitution, and shows that the power factor can readily be determined at the same time. This quantity gives valuable information as to the quality of the condenser, the absorption, and the change of capacity of the condenser with frequency.

M. CHARLES FÉRY has constructed a very simple calorimeter for determining the calorific power of gases and liquids, and gives a description of it in the November number of the *Journal de Physique*. The combustion is effected at the base of a glass chimney, the top of which supports a nickel plate pierced with a number of holes. The air necessary for combustion passes down a similar chimney, which is connected at its base with the former. The two junctions of a constantan-copper thermo-circuit are placed at the tops of the chimneys, and M. Féry finds that the electromotive force in the circuit is strictly proportional to the calorific power of the combustible and to the volume of it consumed in unit time.

MESSRS. BEMROSE AND SONS, LTD., have published the twelfth volume of the new series of the *Reliquary and Illustrated Archaeologist*, which contains the quarterly numbers of the review published during 1907. The separate

issues have been referred to from time to time in these columns. It will suffice to state here that the review is now edited by the Rev. Dr. J. Charles Cox, and is devoted to the study of the early Pagan and Christian antiquities of Great Britain, the development of the arts and industries of man in past ages, and the survival of ancient usages, and kindred subjects. The price of the volume is 12s. net.

OUR ASTRONOMICAL COLUMN.

NOVA PERSEI, 1901.—To test the question of possible proper motion in Nova Persei (No. 2), Prof. Barnard has recently repeated his measures of the Nova's position in regard to other stars in the neighbourhood, using the 40-inch refractor of the Yerkes Observatory. Comparing the results with those obtained in 1901-2, he finds no evidence of measurable motion. The present magnitude of the Nova is about 11.6, the star having apparently increased somewhat in brightness of late (*Astronomische Nachrichten*, No. 4220, p. 323, December 12).

PROVISIONAL ELEMENTS FOR THE SPECTROSCOPIC BINARY α ANDROMEDÆ.—In No. 4220 of the *Astronomische Nachrichten* (p. 327, December 12), Dr. H. Ludendorff publishes a provisional set of elements for the orbit of α Andromedæ, which star has been announced, by several observers, as a spectroscopic binary. This following set of elements has been calculated from the measurements of thirty-eight plates:—

$$\begin{aligned} U &= 97^{\circ} 0' & \omega &= 70^{\circ} \\ V &= -14 \text{ km.} & \epsilon &= 0^{\circ} 4' \\ A &= 34 \text{ km.} \quad B = 26 \text{ km.} & T &= 1904 \text{ Dec. 2} \\ u_1 &= 98^{\circ} & a \sin i &= 36,000,000 \text{ km.} \end{aligned}$$

PHOTOGRAPHS OF MARS.—The second of Prof. Lowell's series of articles on Mars, which is appearing in the *Century Magazine*, is published in the December number (vol. lxxv., No. 2, p. 303). In it the author gives an account of the inauguration and the work of, and of the results obtained by, the Lowell-Todd expedition to the Andes for the observation of Mars under conditions which could not be obtained in higher latitudes and less favourable climates. One of the reproductions illustrating the article shows the Amherst telescope in position at Alianza, Chile, surrounded by the members of the expedition; five other reproductions show prints from some of the plates obtained, each plate containing from sixty to ninety images of the planets, and, alongside, drawings made at the same time by Prof. Lowell, located some 6000 miles away, show how faithfully the photographs confirm the visual observations made at the Lowell Observatory. On the best series of photographs, obtained on July 25, are to be seen delicate canaliform markings which entirely refute the suggestions that such markings, previously recorded visually, are merely subjective phenomena.

Prof. Lowell states that the results greatly exceed his most sanguine expectations, and concludes his article with the following paragraph:—"That life is there is founded on no assumption, but on massed evidence that is conclusive, and the reader should realise that opposition to the idea that we now have proof of life on Mars is not based on reason, but on emotion, however speciously cloaked. All scientific objections have been met and shown untenable as to temperature, snow, &c., but human prejudice, as with the Copernican system or the origin of species, time alone can dispel."

SATURN APPARENTLY WITHOUT RINGS.—In the December Bulletin of the *Société astronomique de France* (p. 513) M. Flammarion discusses the recent observations of Saturn, paying particular attention to the phenomenon of bright knots, observed by Prof. Campbell, and confirmed by Prof. Lowell and others. In this connection he reproduces two drawings made by Bond showing "breaks and prominences" on October 28 and November 3, 1848. These interruptions in the light of the ring were then so easily seen that the observer did not hesitate to explain the phenomenon by the light reflected from the interior edges of the rings.

PRIZES PROPOSED BY THE PARIS ACADEMY OF SCIENCES FOR 1909.

Geometry.—The Francaeur prize, 1000 francs, is awarded annually for discoveries or work useful to the progress of pure and applied mathematics. For the Bordin prize, 3000 francs, the question proposed is as follows:—The absolute invariant which represents the number of distinct double integrals of the second species of an algebraic surface depends on a relative invariant ρ , which plays an important part in the theory of the integrals of total differentials of the third species and in that of algebraic curves traced on the surface. It is proposed to make a profound study of this invariant, and especially to find out how to determine its exact value, at least, for numerous kinds of surfaces.

Mechanics.—A Montyon prize, 700 francs, for inventing or improving instruments useful to the progress of agriculture, the mechanical arts, or sciences. The Poncelet prize will be awarded for a work on applied mathematics. The question for the Vaillant prize, 4000 francs, is to improve in an important point the application of the principles of the dynamics of fluids to the theory of the screw. The Boileau prize, 1300 francs, is for researches on the motion of fluids, sufficient to contribute to the progress of hydraulics.

Navigation.—The Plumey prize is for improvement of steam engines or any other invention which has most contributed to the progress of steam navigation.

Astronomy.—The Lalande prize, 540 francs, is for the most interesting observation, memoir, or work useful to the progress of astronomy, and the Valz prize, 460 francs, is awarded on similar terms. The G. de Pontécoulant prize, 700 francs, is for the encouragement of researches in celestial mechanics.

Geography.—The Tchihatchef prize, 3000 francs, for the recompense or encouragement of young naturalists distinguished in the exploration of the lesser known parts of Asia.

The Gay prize, 1500 francs, for the study of the geographical distribution of one class of cryptogams.

Physics.—The Hébert prize for the author of a treatise or discovery for the application or practical employment of electricity; the Hughes prize, 2500 francs, for a discovery or work contributing to the progress of physics; the Gaston Planté prize, 3000 francs, for the discovery of an invention or important work in the field of electricity; the L. La Caze prize, 10,000 francs, which cannot be divided, for works or memoirs contributing to the progress of physics.

Chemistry.—The Jecker prize, 10,000 francs, for works contributing to the progress of organic chemistry; the Cahours prize, 3000 francs, for the encouragement of young chemists; the Montyon prize (unhealthy trades), a prize of 2500 francs and a mention of 1500 francs, for the discovery of a means of rendering an art or trade less unhealthy; the L. La Caze prize, 10,000 francs, which may not be divided, for the best work in chemistry.

Mineralogy and Geology.—The grand prize of the physical sciences, 3000 francs. The question proposed for 1909 is the stages of evolution of the most ancient quadrupeds found in France. The Delesse prize, 1400 francs, for a work concerning geology, or, in default, mineralogy.

Botany.—The Desmazieres prize, 1600 francs, for a work on cryptogams; the Montagne prize, 1500 francs, for important work bearing on the anatomy, physiology, development, or description of the lower cryptogams; the de Coigny prize, 900 francs, for a work on phanerogams; the Thorez prize, 200 francs, for a memoir on the cellular cryptogams of Europe.

Anatomy and Zoology.—The Savigny prize, 1500 francs, for the assistance of young travelling zoologists, not receiving Government assistance, who occupy themselves especially with the invertebrates of Egypt and Syria; the Da Gama Machado prize, for the best memoir on the coloured parts of the tegumentary system of animals.

Medicine and Surgery.—The Montyon prize, a prize of 2500 francs, and mentions of 1500 francs, for works or discoveries useful in the art of healing; the Barbier prize, 2000 francs, for a discovery in surgical, medical, or pharmaceutical science, or in botany with relation to

medicine; the Bréant prize, 100,000 francs. The capital sum will be awarded under the terms of the legacy to anyone discovering a radical cure for Asiatic cholera, either by a specific medicine or by discovering the causes and indicating an undoubted method of destroying these causes. In default of this, the annual interest will be awarded for a memoir demonstrating in a rigorous manner the presence of materials in the atmosphere playing a part in the production or propagation of epidemic diseases. The Godard prize, 1000 francs, for the best memoir on the anatomy, physiology, or pathology of the genito-urinary organs; the Baron Larrey prize, 750 francs, for an army or navy doctor or surgeon for a work treating of military medicine, surgery, or hygiene; the Bellion prize, 1400 francs, for work forwarding the progress of medicine; the Mège prize, interest on 10,000 francs.

Physiology.—The Montyon prize, 750 francs, for work in experimental physiology; the Philippeaux prize, 900 francs, for similar work; the Lallemand prize, 1800 francs, for researches on the nervous system. The question proposed for the Pourat prize, 1000 francs, for 1909, is the origin of the anti-ferments.

Statistics.—A Montyon prize, prize 1000 francs and a mention of 500 francs, for work having a bearing on French statistics.

History of Science.—The Binoux prize, 2000 francs, for works on the history of science.

General Prizes.—The Arago, Lavoisier, and Berthelot medals. The Gœgner prize, 3800 francs, for researches in the positive sciences; the Lannelongue prize, 2000 francs, for the assistance of the relatives of scientific men; the Trémont prize, 1100 francs. The Wilde prize, one of 4000 francs and two of 2000 francs, for work in astronomy, physics, chemistry, mineralogy, or experimental mechanics; the Longchamp prize, 4000 francs, for a work on the diseases of man, animals, and plants, from the special point of view of the introduction of excess of mineral substances as the cause of disease; the Saintour prize, 3000 francs; the Victor Raulin prize, 1500 francs, to facilitate the publication of works relating to geology and palæontology, mineralogy and petrography, meteorology and physics of the globe, the prize for 1909 being limited to mineralogy and petrography; the prize founded by Mme. la Marquise de Laplace; the Félix Rivot prize, 2500 francs; the Jean Jacques Berger prize, 15,000 francs, for work concerning the City of Paris; the Petit d'Ormay prize, two prizes of 10,000 francs, one for pure and applied mathematics, and the other for natural science; the Pierson-Perrin prize, 5000 francs, for a physical discovery; the Parkin prize, 3400 francs, for researches on the curative effects of carbon in cholera, different forms of fever, and other diseases, or on the effects of volcanic action on the production of epidemic diseases; the Cuvier prize, 1500 francs, for a work on zoological palæontology, comparative anatomy, or zoology.

Of the above, the Lalande, Tchihatchef, La Caze, Delesse, Desmazieres, and Wilde prizes, and the Lavoisier medal, are expressly offered without distinction of nationality; the Gaston-Planté, Montagne, and Pierson-Perrin prizes are limited to persons of French nationality.

RECENT WORK OF GEOLOGICAL SURVEYS.

THE Geological Survey of Great Britain has issued its "Summary of Progress for 1906" (1907, price 1s.), from which it is clear that a large part of the work of the staff must always be devoted to the revision of geological details in areas already mapped. This is not work that can be carried out hurriedly, or in response to every change in popular geological opinion; but the real need for re-consideration in accordance with modern discovery is at once apparent from the results recorded on pp. 2 to 5 of the present summary. Geological surveys have an important educational duty in addition to their economic functions, and one can never predict where an accurate knowledge of the earth may not lead to the foundation of an industry, or where an industrial inquiry may not suddenly illumine our relation to this globe on which we have to spend our lives.

It is pleasant to observe (p. 6) that the Geological Survey of Great Britain has been in conference with the Agri-

cultural Education Association "for the purpose of testing the relationship of the geological boundaries and the soils." On p. 110 the palaeontologists report in favour of the view that the rugose corals were primarily hexamerous, a question still under discussion, as may be seen from a note in *NATURE*, vol. LXXVI., p. 117. The original papers in the appendix, corresponding to the well-known *Bulletins of the Geological Survey of the United States*, include one by Dr. Flett on the scapolite-bearing rocks of Scotland, and a valuable summary by Mr. D. A. Macalister of the quantity of tin, copper, and other minerals produced in Cornwall.

The "solid" and "drift" maps, Nos. 230 and 247, are issued simultaneously with the memoirs describing them, under the care of Dr. Aubrey Strahan, and cover parts of the great South Wales coalfield (1907, memoirs, price 2s. 6d. each; maps, 1s. 6d. each). The former memoir deals with the country round Anmanford, north of Swansea, where the Silurian strata, through the Ludlow Limestones, pass up into the Red Marls that form the base of the Old Red Sandstone. The usual unconformity of the latter on a Caledonian land-surface is revealed, however, by the fact that it oversteps every member of the Silurian system (p. 53), until it rests directly on the Arenig rocks in the extreme north-west of the map. The details shown on these modern maps necessitate a good deal of freedom in the use of colours, and blues and greens and yellows are used for lithological divisions (which are, of course, supported by palaeontology) in a way that would hardly commend itself to the soul of William Smith. Would not a variety of linings and stipplings in the same colour, which produce all the effect of separate tints, serve on such colour-printed maps for minor subdivisions of our British systems? The American and New Zealand surveys often provide us with examples.

We note (p. 37 of Memoir No. 230) that "Ordovician" now officially replaces the "Lower Silurian" of the older survey; but is it wise to restrict "Silurian," in the face of almost all the geological world, to the former "Upper Silurian" alone? Prof. De Lapparent in 1893 at any rate showed us a clear way out of the difficulty.

Memoir No. 247 includes the busy town of Swansea, and the map brings us to the southern edge of the great coalfield. Mr. E. E. L. Dixon (pp. 11-20) furnishes an interesting account of the domitisation of the limestone soon after its deposition in the Carboniferous sea, and the plates and descriptions ought to be useful to workers in many other districts. The growing difficulty in drawing a line between the Lower and Upper Carboniferous series in Britain is well seen by the remarks on pp. 28-29. Mr. Tiddeman (p. 121) has traced a pre-Glacial raised beach from Mumbles Head westward, the fauna of which shows that the whole Cainozoic Glacial epoch was an episode of our own times, if we take the mollusca as our guide. It is now urged (p. 127) that *Rhinoceros*, *Elephas*, *Bos*, and *Cervus*, found in the Gower Caves, lived here before the arrival of the ice, since raised beach deposits admittedly appear in the cavern-floors. The subsidence that was shown at the Barry Docks in Cardiff to be later than Neolithic times has carried peat in the Swansea area (p. 145) to a level of 44 feet below high water.

The memoir on the geology of Islay has also appeared (1907, price 2s. 6d.). The author, Mr. S. B. Wilkinson, is referred to in other memoirs as Mr. B. S. N. Wilkinson, a point of which bibliographers should take notice. The maps here described were issued some years ago, and cover a little visited and very attractive district. The ordinary pedestrian in Jura and Islay will find much romantic ground, and may still travel by introduction from one farm to another, in the good old highland style. The present writer well remembers how he was waylaid by an old peasant woman early one morning on the Jura pathway, and forced to accept a parcel of oatcake, lest he should weary before reaching the ferry at the north end of the island.

Mr. Wilkinson enables us, in his first chapter, to realise the main features of Islay, and he rightly directs attention to the extreme brilliance of the colouring on sunlit days along the coast. The rocks include much crushed and mylonitic Lewisian gneiss; sediments regarded as Torridonian; phyllites, limestones, and quartzites, corre-

lated with the Central Highland series; and, resting on these with a slight unconformity (p. 44), a series in which dolomite is prevalent. A considerable thrust-plane separates the quartzite and conglomerate of this series in the north of the island from the rocks referred to the Torridonian. Drs. Teall and B. N. Peach have made important contributions to this memoir. It is illustrated by photographic plates of exceptional beauty. It was unnecessary, however, to supply Plate ii. in our copy in the condition of a "proof before letters."

In the *Verhandlungen der k.k. geologischen Reichsanstalt* for 1907, Herr Vacek (p. 159) continues the controversy with Herr Heritsch on the basin of Graz, and we are led to understand that the junior author, whose youth is greatly insisted on, may now be carried off the field. He is sagely advised not to quote authorities, but to become one himself. Surely we have heard something of this kind in geological exhortations nearer home.

Herr Ampferer (p. 192), in his usual systematic style, gives a reading of the structure of the Rhätikon range on the Swiss and Austrian frontier, in which he shows that he is not fascinated by what Schardt has called "Ultranappismus." Ampferer goes so far as to suggest that certain foreign blocks amid Tithonian limestone, regarded by von Seidlitz as evidence of a "Fenster," and thus connected with overfolding, have been brought into their present position by ice which overrode the chain.

The *Jahrbuch* of the same institute for 1907 contains many descriptive papers, from von Troll's study of the Pontic fauna in the basin of Vienna (p. 33) to Schubert's work on the north Dalmatian coast (p. 1). Dr. Schubert incidentally opposes the suggestion, made from a study of old maps, that extensive geographical changes have occurred in the Adriatic isles within historic times.

Dr. Hinterlechner (pp. 115-374) contributes an important memoir on the sheet of the map round Deutschbrod (Německý Brod, the German ford), in eastern Bohemia. A broad plateau of gneiss and granite here unites Bohemia and Moravia; the traveller may find it monotonous, but for the fantastic architecture of its towns. Dr. Hinterlechner shows what problems of metamorphism lie beneath its undulating fields and little woods. He urges (p. 332) that the great mass of the cordierite and biotite gneisses result from the contact-alteration of a sedimentary series, which has been left intact in one particular zone. Rocks once regarded as Archaean are shown to be intrusive in this sedimentary envelope (p. 351), the age of which remains uncertain. Here again we note the striking change of opinion forced on observers in many lands when careful field-investigation comes to be carried on. Almost all our recent researches lead us farther away from the supposed Archaean crust of purely igneous origin.

Walery Ritter von Lozinski describes in the same journal (p. 375) the glacial deposits and löss of northern Galicia, and traces the ice-tongues of the epoch of maximum glaciation into the northern valleys of the central Carpathian range. He finds (p. 395) that the thin marginal ice of the great continental sheet moved to a considerable height up gentle slopes, but was unable to climb steeper hillsides. Unglaciated areas therefore appear, say 250 metres above the sea, side by side with others invaded by ice to a height of 300 metres.

Among palaeontological papers may be cited a long memoir by Dr. A. Till on the jaws of fossil cephalopods (*ibid.*, pp. 535-682), an outcome of his previous studies on the examples found in the Neocomian (*ibid.*, 1906, p. 89). Four new genera are proposed, and the jaws belonging to *Nautilus* are marked off clearly from all others (p. 658). The latter types diminish rapidly at the close of Lower Cretaceous time, and the author (p. 680), in consequence, suggests that they were connected with the Belemnoida. Throughout both the memoirs referred to, Dr. Till writes "Rhynchotheutis" and "Palaeotheutis" consistently; but surely this is a curious error in one who is so much a specialist.

The *Bulletins de la Commission géologique de Finlande* are always of interest. In No. 23 (June, 1907) Mr. Sederholm writes, with an English summary, on "granite and gneiss, their origin, relations, and occurrence in the pre-Cambrian complex of Fenno-Scandia." The subject is one in which the author has already made a reputation. Like Hinter-

lechner, quoted above, and many others, he has been forced here to oppose the notion of a primitive crystalline crust, revealed to us in a region of Archaean rocks, and urges that the oldest rocks in this district are of sedimentary origin, penetrated by younger granites. "The strongly contorted structure" (p. 99) "characteristic of most Finnish gneisses . . . is not a secondary phenomenon in truest sense, but originated when the rock was in a

In the "Administration Reports of Ceylon for 1906 (Mineralogical Survey)," Dr. Coomaraswamy records the discovery of thorianite *in situ* by Mr. Parsons in a vein of pegmatite, to which the mineral was traced by following up the alluvial deposits in the bed of a seasonal stream. About 6 lb. of thorianite occur in a ton of the wet decomposed pegmatite. A geological map of part of the Kandy district is added to the report.

Vol. vi. of the "Records of the Mysore Geological Department" contains several coloured maps. It is suggested that the manganiferous laterite in the Shimoga district, now being mined, may represent an old lake-deposit. The work done by the survey is of a wide character; but may we suggest that such terms as "geology student" and "topo sheets" do not fairly represent the English language?

The "Geologists' Report of Progress for September, 1903, to January, 1907, for the Federated Malay States," by Mr. J. B. Scrivenor (Kuala Lumpur, 1907, price 1 dollar), is another interesting piece of evidence as to present geological activity. A distinct foundation is laid in this pamphlet for a conception of the structure of the south end of the Malay peninsula, but the dense vegetation is here, as in Borneo, a serious obstacle to the explorer. On p. 18 there is a remarkable reference to Mr. H. N. Ridley's discovery of an alga instrumental in producing laterite. Of this we shall hope to hear much more;

possibly Mr. T. H. Holland, the originator of the organic view of laterisation, has already looked into the matter.

Bulletin No. 3 of the New Zealand Geological Survey contains Mr. J. M. Bell's report on the Parapara subdivision, Karamea, at the north-west corner of the South Island. It is well furnished with landscape illustrations, as is usual with these publications, and a series of beauti-



FIG. 1.—Miocene strata, near Rockville, west of Golden Bay, Nelson, New Zealand.

melting condition." This is supported by a series of photographs of rocks intimately penetrated by granite veinlets. The author "regards the foliation of the granites, where it is not of dynamo-metamorphic origin, as formed by the incomplete melting and re-crystallisation of schistose rocks. Also the spotting of granites, he ascribes, in most cases, to the existence of incompletely resorbed fragments of older rocks."

At the same time, he believes that the foliation of many Finnish granites was due to pressure after they had become solid (p. 100), and that in Finland "the basement complexes of the typical Archaean sedimentary formations are often preserved." But the base of the whole series in Fenno-Scandia has been melted up; mixed rocks, therefore, play a very important part in this area. Hutton's conception of the circulation of types of rock through denudation of the crystalline masses and their gradual renewal, appears to Sederholm to be fully justified (p. 102). The word "migmatite" is proposed for the rocks that have been called by others "composite gneiss."

In Bulletin No. 21 Mr. Tanner continues his studies on the glacial phenomena of Finmark, and urges that, allowing for temporary advances of the ice during a general epoch of recession, the glaciation may here be regarded as continuous, without an interglacial break.

Turning eastward, we find Dr. W. F. Hume reporting on the geology of the eastern desert of Egypt (Ministry of Finance, Survey Department, Cairo, 1907). Gold-mining was carried on here in ancient days, and has recently been revived; the gold occurs in quartz-veins. The present account of the geology is merely preliminary, but includes the record (p. 29) of a new marine fauna in the Cretaceous sandstone.



FIG. 2.—Bued River Valley, northern Luzon, Philippine Islands.

fully executed maps is inserted in a pocket at the end. The geological history of the district in Cainozoic times emphasises our growing convictions as to the almost world-wide occurrence of the same physical phenomena in certain geological epochs. In this corner of New Zealand, as in central Europe and Armenia, for example, we have a Miocene depression, with a marine invasion (see Fig. 1), occupying the valleys of the previous land, and then "a

period of secular elevation, accompanied by faulting on an extensive scale. Gradual uprise of the land was continued practically into modern times." An epoch of extensive glaciation, with the formation of an ice-sheet in the basin of Boulder Lake, then opened in Pliocene or post-Pliocene times (p. 22). Especial attention is directed in this bulletin to the immense deposits of limonite iron-ore associated in the district with an ancient series of carbonate rocks. The ore is ascribed to the decay of iron pyrites, and to the reaction of the resulting ferrous sulphate on the carbonates. The ferrous carbonate has finally been altered to limonite, probably as a surface-phenomenon; but the resulting ores occur on a vast scale, highly encouraging for their future prospects (pp. 75-88).

The Bureau of Science of the Government of the Philippine Islands is responsible for the admirably produced *Philippine Journal of Science*, an example to our Government printers in India, or perhaps an example of the disparity of the funds officially devoted in the two countries to scientific publications. In vol. ii., No. 4 (Manila, August, 1907), Mr. A. J. Eveland describes the geology and geography of the Baguio mineral district. Here again, in the island of Luzon, we find an old crystalline basis, marine Eocene (?) and Miocene beds laid down upon it, and then an epoch of elevation and denudation. The Miocene limestone is cut through by the present Bued River valley, which reaches down to the basal diorite (Fig. 2). G. A. J. C.

ARCHÆOLOGY IN AMERICA.¹

THE first part of the second volume of the Transactions of the University of Pennsylvania's Department of Archaeology, Free Museum of Science and Art (it is a pity that this cumbersome title cannot be simplified), contains the usual instalment of articles on Cretan and Mexican archaeology, with interesting contributions by Mr. G. B. Gordon on the western Eskimo of Alaska and on an engraved bone from Ohio, the decoration of which is very Mexican in character. The author of the article on Mexican archaeology, Miss Adela Breton, draws interesting analogies between the Mexican conventional representations of serpents and the dragons of Chino-Japanese art. There certainly seems to be some connection, however it may be explained. The explanation, when it arrives, will, however, be a genuine one, and not on the lines of the late Mr. Donnelly's "Atlantis," with its curious comparisons of Maya signs with "Egyptian hieroglyphics," most of which had no real existence. It is a pity that the investigation of possible connections between Mexican culture and those of the rest of the world has been so seriously discredited by the "Atlantis" idea. Miss Breton's description of the Xochicalco temple is interesting reading.

Mr. Gordon describes, among other "ploys" of the Eskimo, their elaborate cat's-cradle games. From a personal trial we cannot say that his recipes for their production are as clearly put as they might be. The photographs of these Eskimo which Mr. Gordon publishes show a Mongol rather than American type; plate v., 2, might, but for the eyes being rather too deeply set, be a Japanese.

The Cretan contribution is a good article on "The Decorative Art of Crete in the Bronze Age," by Miss Edith H. Hall, who worked at Gourniá with Miss Boyd (Mrs. Hawes). As a succinct description of the most striking characteristics of the succeeding "Minoan" periods of Cretan artistic development it is very useful, and supplements Dr. Evans's "Essai de Classification" and Dr. Mackenzie's articles on pottery in the "Journal of Hellenic Studies" and the "Annals of the British School at Athens." In tone Miss Hall is perhaps just a trifle too dogmatic, and dismisses the opinions of others (e.g. Mrs. Hogarth and Welch once or twice) too summarily. On Egyptian matters, too, she is inclined to regard as certain what those who deal with Egyptian things at first-

hand know to be thoroughly uncertain. The later system of Egyptian dates is adopted (p. 12) from Prof. Breasted's history with hardly a qualm, in spite of the fact that it is not yet accepted by Petrie, Maspero, von Bissing, or Budge (to give only the most prominent names). There are growing reasons in favour of it, true; but equally there are most serious considerations to be urged against it. To talk dogmatically of the XVIII Dynasty as ending "in 2475 B.C." (the italics are mine), or the XIII as dating "from 2000 to 1788 B.C.," is absurd, though Miss Hall is not responsible for the absurdity.

Also, Miss Hall makes the usual mistake of the Greek archaeologist, a mistake which we had occasion to correct in the case of her colleague Mr. Seager last year, in persistently regarding all Egyptian representations of plants, flowers, and so forth, as stiff and conventional. They are not invariably so, as a study of plant designs on XVIIIth Dynasty pottery from Deir el-Bahari and elsewhere shows; it is these, and not the formal *dadoes* of papyrus plants in wall paintings, that we must compare with the plant designs of the Cretan artists. Miss Hall's Fig. 29 is quoted as a Cretan "adaptation of the lotus clumps of Egyptian art. Here the method of arranging the flowers," she says, "is the same as in Egyptian art, yet every trace of Egyptian stiffness is gone." I could quote several examples of Egyptian representations of flowers that are far less stiff and formal than this Cretan one. The designs of Figs. 35, 48, and 49 could all be paralleled on Egyptian pottery.

Miss Hall's classificatory table of "Cretan Bronze Age Design" is very useful as a conspectus of the chief examples of the designs of the "Minoan" periods.

H. R. HALL.

THE PELYCOSAURIAN REPTILES.¹

ALMOST exactly thirty years ago the late Prof. Cope brought to the notice of the scientific world remains of certain remarkable carnivorous reptiles from the Permian strata of Texas, for which he proposed the group-name Pelycosauria. The group was regarded as a suborder of the Rhynchocephalia, and was provisionally taken to include the theriodont reptiles of South Africa. Among the more typical representatives of the pelycosaurs are Dimetrodon and Naosaurus, extraordinary reptiles in which the dorsal spines of the trunk vertebræ are so enormously elongated (sometimes with the addition of transverse projections) that they exceed in height the depth of the body below them. Restorations of both the skeleton and the external form have now rendered these creatures familiar even to the man in the street.

As to the systematic position of these reptiles and their kindred, considerable diversity of view has obtained. By many writers they are classed with the theriodont anomodonts, but this, according to modern ideas, is altogether unjustifiable, the structure of the temporal arches in the two groups being different. Dr. Case therefore reverts to the original view that pelycosaurs form a primitive section of the rhynchocephalians.

The group is of special interest as illustrating, perhaps better than any other, the rapid evolution from a generalised type to a complex organisation that may have been the potential cause of early extinction, the life of these reptiles being coterminous with the duration of the Permian epoch. Why these specialised structures were evolved within such a comparatively short time is a subject upon which we can only conjecture. Carnivorous in habit, and easily masters of their contemporaries, these reptiles, Mr. Case suggests, may have developed their spines from mere exuberance of growth from a utilitarian beginning, but that these structures eventually became useless cannot be doubted.

That pelycosaurs existed outside of North America is proved by the occurrence of Naosaurus in the Permian of Bohemia and of Stereorhachis in that of France, while certain reptiles from central Germany may also belong to the group. On the other hand, they are unknown in South-

¹ University of Pennsylvania: Transactions of the Department of Archaeology, Free Museum of Science and Art, vol. ii., part i., pp. 105-120 plates. (Philadelphia: Published by the Department of Archaeology, 1906.) Price 1 dollar.

¹ "Revision of the Pelycosauria of North America." By F. C. Case. Publication No. 55. Pp. 176+35 plates. (Carnegie Institution, Washington, D.C., 1907.)

Africa or India, and it is improbable that they are represented in the Russian Permian. If this be so, pelycosaurs are unknown in any country where anomodonts (in the wider sense of that term) occur, so that the two groups may apparently be regarded as belonging to totally distinct faunas.

Dr. Case appears to have done his work very thoroughly, and the memoir is profusely illustrated. Before, however, expressing an opinion as to whether his restorations of cranial, and especially palatal, osteology are trustworthy, it would be essential to compare the original specimens with the figures.

R. L.

UNIVERSITY AND EDUCATIONAL INTELLIGENCE.

By the will of Sir William G. Pearce, Bart., chairman of the Fairfield Shipbuilding and Engineering Co., Ltd., who died on November 2, Trinity College, Cambridge, will benefit to the extent of more than 400,000. upon the death of Lady Pearce, should he have left no child.

The joint matriculation board which directs and controls the matriculation examination of the universities of Leeds, Liverpool, Manchester, and Sheffield has issued its report for the year 1907. The number of candidates in July was 1,294, of whom 705 passed; and in September was 438, of whom 170 passed. The board has appointed a committee to draft a scheme for the inspection and examination of schools, and it has been assured by the universities of their general approval of the objects of the proposal.

A CONFERENCE of teachers, arranged by the London County Council, will be held at the Medical Examination Hall, Victoria Embankment, London, on January 2, 3, and 4. Two meetings will be held each day, and begin at 11 a.m. and 2 p.m. The subject for the first meeting will be nature-study, and addresses will be delivered by Dr. T. P. Nunn and Messrs. H. E. Turner and J. T. Winkworth. At the second meeting the teaching of botany will be discussed, and the speakers will include Miss Lulham, Miss Lillian Clarke, and Miss von Wyss. At the fifth meeting, manual work in the lower standards of elementary schools will be considered, and Dr. Slaughter and Messrs. J. C. Hudson and P. B. Ballard will speak. At the last meeting Mr. W. J. Hazlitt will read a paper on open-air geography. Applications for tickets of admission should be made to Dr. Kimmins, Education Department of the London County Council, Victoria Embankment, W.C.

THE annual meeting of public school science masters will be held at Westminster School on January 14, 1908. The meeting will commence at 10 a.m., when an exhibition of scientific apparatus will be opened. During the morning the president, Prof. H. A. Miers, F.R.S., will deliver an address upon the order in which science subjects should be taught (a) in public schools, (b) at the universities. In the morning also a discussion on teaching mechanics will be opened by papers on the educational value of mechanics by Mr. C. F. Mott, of Giggleswick School, and on the teaching of practical mathematics by Mr. H. Wilkinson, of Durham School. In the afternoon a discussion on teaching physics will take place, when papers will be read by Mr. C. Cumming, of Rugby School, on a scheme of laboratory work in physics; Mr. W. E. Cross, of Whitgift Grammar School, on a suitable curriculum for the first and second years; and Mr. J. M. Wadmore, of Oldenham School, on the compulsory teaching of elementary physics to junior forms.

SOCIETIES AND ACADEMIES.

LONDON.

Royal Society, December 5.—"On the Distribution of the Different Arteries supplying the Human Brain." By Dr. C. E. Beevor. Communicated by Prof. David Ferrier, F.R.S.

The area of distribution of the different arteries of the brain was ascertained, when they were injected simul-

aneously under the same pressure with gelatin containing soluble colours, a method not used before.

The number of brains injected was eighty-seven. The arteries injected were the posterior communicating, the anterior choroid, the anterior cerebral, the middle cerebral, and the posterior cerebral.

The method of investigation consisted in injecting simultaneously by means of pressure bottles, three, four, or five of these arteries with different soluble colours. The injection mass used was gelatin, coloured with soluble carmine, Nicholson's blue, naphthol green, acridine yellow, and Bismarck brown. Twelve different classes of experiments were described. The brains were hardened in formalin, and subsequently cut and examined in the sagittal, horizontal, or coronal planes.

The parts of the brain, the arterial supply of which hitherto has not been described, or which was found to be different from that described by other observers, are:—

The regio subthalamica, with the corpus subthalamicum and Forel's field; the pes pedunculi; the corpus mammillare; the anterior limb of the internal capsule; the caudate and lenticular nuclei; the different nuclei of the optic thalamus (the thalamus is not supplied by the lenticulo-optic arteries of Duret); the anterior part of the choroid membrane, which is supplied by the anterior choroid artery; the fornix and the anterior commissure. The absence of anastomoses of the three arteries supplying the posterior limb of the internal capsule and of the two arteries to the head of the caudate nucleus was also noted.

In the cortex, the anterior cerebral area extends on the outer surface along the median line posteriorly, most frequently to mid-way between the Rolandic fissure and the external parieto-occipital fissure, and inferiorly to the sulcus frontalis superior. The middle cerebral area on the outer surface reaches the middle line for the posterior half of the parietal lobe, and posteriorly the posterior pole, or half an inch in front of it, and inferiorly the middle of the third temporal gyrus. The occipital fibres of the optic radiations in the superior lip of the calcarine fissure are usually supplied by the middle cerebral artery, and in the inferior lip by the posterior cerebral, except for about the posterior inch, which is supplied entirely by the posterior cerebral.

The knowledge of the exact part of the brain which is supplied by an artery is of great importance in the diagnosis of the parts of the brain which undergo softening when this particular artery is blocked by a blood clot.

"The Influence of Increased Barometric Pressure on Man. No. 4. The Relation of Age and Body Weight to Decompression Effects." By Leonard Hill, F.R.S., and M. Greenwood, jun.

Conclusions.—(1) Small mammals are relatively immune from decompression effects.

(2) This immunity depends on rapidity of circulation, and may be destroyed by damaging the latter with chloroform.

(3) Age is probably important *per se*, but of far less importance than body weight. We have no convincing proof that two animals of the same weight but different ages would exhibit unequal resisting powers.

(4) There is no evidence that small animals are more quickly poisoned by high pressures of oxygen than large ones.

The practical outcome of this research is that young men of small body weight and possessing a vigorous circulation should be selected for compressed air works.

Royal Meteorological Society, November 20.—Dr. H. R. Mill, president, in the chair.—Reports on the results obtained by the balloon observations made in the British Isles, July 22-27. The International Aeronautical Commission has for some years set apart the first Thursday in each month for the ascent of kites and balloons, but at last year's conference it was decided to make a special effort to obtain information on a series of consecutive days, and the last week in July was finally decided upon for the purpose. Twenty-five balloons with registering instruments were sent up in England and Scotland during the week, under the direction of Mr. W. H. Dines, at Pytton

Hill, Oxon, and at Crinan, on the west coast of Scotland; Mr. J. E. Petavel, at Manchester University; Captain C. H. Ley, R.E., at Sellack, Herefordshire; and Mr. C. J. P. Cave, at Ditcham Park, Petersfield. Fourteen of the registering instruments have been found. Prof. W. E. Thrift also sent up a number of pilot balloons from Dublin. Nearly all the balloons drifted to the eastward, but several which reached a fair height fell within twenty miles of their starting point. The heights ranged up to more than 12½ miles, the average being about 7½ miles. The records show that above 7½ miles the temperature remained almost unaltered with change of height.—Discussion of the meteorological observations at the British kite stations, session 1906-7: Miss M. White, T. V. Pring, and J. E. Petavel. The authors found that the temperature gradient varies with the direction and the velocity of the wind, and also with the amount of clouds, being greatest for a north-west wind, and on clear and fine days. It appears that the direction of the wind alters at high levels, rotating in a clockwise direction; thus a south wind tends to become more westerly.

December 18.—Dr. H. R. Mill, president, in the chair.—The possibility of a topography of the air, based on balloon observations with special theodolites: Capt. C. H. Ley. The author gave the results of his own observations in Herefordshire in connection with the international balloon ascents which were carried out during the past summer. His method of observing is based on the direct estimation of the range of the balloon from its apparent diameter as measured by cross threads in a telescope; the range being thus determined, an altitude and azimuth are read, and the position if the balloon fixed and plotted on a map. The author, in conclusion, states that the varying topography of the earth's surface produces disturbances in the atmosphere with effects which are transmitted throughout the lower and middle strata; and that the general effect on a current is to increase its velocity over a hill and decrease it over a valley, and this is especially the case with the vertical velocity. The origin of the phenomena is to be sought in the mechanical effect of obstruction of the lowest stratum, but there are probably various ensuing complications which may accentuate the result. The measurement of these effects can be carried out by a topography of the air made in any locality.—Indications of approaching frost: R. Strachan. For the purpose of making forecasts, the dry and wet bulb thermometers should be noted at or after sunset, or at 9 p.m., and the amount of cloud at the time, and during the forepart of the night if convenient. The dew point can be found by reference to hygrometrical tables. When the dew point is at or below 32° frost is in evidence, but may be evanescent, due to a rise of temperature, with change of wind, rain, or overcast sky. Even when it is above 32°, if the sky is clear it is possible that the temperature on the ground will become low enough for frost to form. Thus the evening observations should lead to a good idea of what may happen during the night.

Royal Microscopical Society, November 20.—Lord Avebury, president, in the chair.—*Exhibits*.—Conrad Beck: Two specimens under microscopes of photographic plates prepared by the Lumière starch-grain process for colour photography. One specimen had been exposed and the other had not. The starch grains, which were about 1/2000-inch in diameter, were stained red, violet, and green. If the object-glass of the microscope showing the unexposed plate be racked out of focus, so that the colours be blended, a very close approximation to white light is obtained. If the objective be only partially out of focus, patches and channels of colour are visible, due to the fact that the coloured grains are not sufficiently intermingled. These patches are what were seen under the microscope exhibited; to see the individual grains a much higher power than the 1-inch used would be required.—C. L. Curties: Two inexpensive microscopes. The first, termed the "nature-study" microscope, was mounted on a heavy square foot. It was non-inclinable, and for observing large objects the stage and mirror could be removed and the specimen placed on the flat base. The other instrument, named the "meat

examiner's" microscope, is of similar design, but the stage has grooves on its upper surface, from front to back, of a pitch equal to the field of view of a 1-inch objective; a compressor having points projecting from its under side to fit into the grooves is supplied; by sliding the compressor in one groove and then in the next, until the whole length has been traversed, the entire specimen can be examined without going over the ground two or three times.—J. T. Pigg: Photomicrographic lantern-slides from nature, showing the various stages in the development of the fern spore from its germination to the mature frond with its fructification.—E. Moffat: A new form of filter for agar and other media.—*Papers*.—The François Watkins microscope: E. M. Nelson.—Mercury globules as test objects for the microscope: J. W. Gordon.—Light filters for photomicrography: E. Moffat.—Demonstration of the use of colour photography in metallurgy: E. F. Law. A number of photomicrographic lantern-slides were exhibited showing the brilliant colours produced on the polished surfaces of alloys by the varying degrees of oxidation caused by the heat-tinting process.

Physical Society, November 22.—Prof. J. Perry, F.R.S., president, in the chair.—Specimens of singing sand from New England: S. Skinner. The specimens shown were from two sea-beaches in New England, one at Manchester, Mass., and the other near Small Point, Maine. The beaches are alike in character in being surrounded by hard rock walls and in not having streams which might bring silt flowing through them. The sands are consequently very clean and free from small particles, and this especially so after each tidal washing. The sand consists chiefly of angular clear quartz fragments. Mr. Skinner has been able to verify most of the facts observed by Mr. Carus Wilson (*NATURE*, 1891), viz.:—(1) the sounds are best obtained by plunging a hard plunger into a glazed cup containing the sand; (2) after a time the production of the sounds becomes difficult; (3) the sounding may be restored by washing, which presumably removes fine powder formed by attrition between the particles; (4) it is necessary that the displacement of the sand by the plunger should occur easily. If there is resistance due to the shape of the vessel, or due to clogging by dust, the sounding is stopped. The theory put forward in "Sound" by Prof. A. Poynting and Thomson seems a reasonable explanation.—A micromanometer: L. Bairstow. The instrument exhibited was one of two which are in regular use at the National Physical Laboratory for measurements of pressures due to air currents. When the pressures on the two sides of the gauge are balanced, the whole of the liquids employed are in their zero positions, and errors due to capillarity and viscosity are avoided. The gauge exhibited has a sensitiveness of 1/10,000th of an inch of water and a range of three-fourths of an inch of water. The gauge is slightly sensitive to temperature due to the expansion of the castor-oil used, but the changes are small and easily allowed for by taking time readings of the zero. The gauge is not suitable for rapidly varying pressures, as considerable distortion of the oil surface leads to an irregularly displaced zero.—A diablo experiment: C. V. Boys. The diablo spool exhibited has the peculiar merit that no one can spin it. It is based upon the following principle. Either the ordinary spool of commerce, which has its moment of inertia about its axis of rotational symmetry a minimum, or a spool not generally made which has the corresponding moment of inertia a maximum, has stable rotation about this axis or about a transverse axis, i.e. if it is temporarily rotating about an axis inclined to one or other, it will tend to shift its momentary axis of rotation and gradually settle down so as to spin about one or other. If, however, the spool is so proportioned that the moment of inertia is identical about any axis, it has no tendency to spin stably about any particular axis, and the axis of rotation wanders about so rapidly that it cannot be spun. A heavy conical sheet projecting equally on either side of the vertex, the semi-vertical angle of which is equal to $\tan^{-1}\sqrt{2}$, has this property, but such an ideal construction is impracticable. All added matter beyond the sheet in the direction of the axis makes the momental ellipsoid more prolate, while any outside the sheet makes it more oblate. Treating,

then, the ideal cone as a skeleton, and clothing it with matter within and without, a material double hollow cone may be made of the form of a diabolo spool, but with the dynamical properties of a sphere. It is preferable, however, to make the spool with an axial hole and with a slight preponderance of moment of inertia about its rotational axis. It will then spin perfectly. It may, however, be easily adjusted by the insertion of a stick, which is cut off of such a length as to make the moments of inertia equal, as tested by suspension from a torsion wire.—A gyroscope illustrating Brennan's mono-railway: Prof. H. A. Wilson. A gyroscope is mounted in bearings so that it can spin about a horizontal axis and precess freely. The gyroscope is further mounted at the top of a rectangular framework. The axis of spin of the wheel is first placed at right angles to the plane of the framework. Attached to the vertical axis about which the precessional motion occurs is a short crank with a spiral spring attached, so that when precession occurs in any direction the precessional couple is increased and the top returns towards its initial position. The oscillations of the gyroscope about its mean position become continually larger until the stability of the arrangement disappears.

Zoological Society, November 26—Mr. G. A. Boulenger, F.R.S., vice-president, in the chair.—Some new and little-known Araneidae: Rev. O. Pickard-Cambridge. Eleven species were noted or described and figured:—one from Lagos, Portugal; three from Cape Colony, South Africa; one from Mashonaland; five from the Canaries; and one from Old Calabar. Seven species were described as new to science. Five of the spiders had been accidentally imported to England in packages of bananas.—New species of beetles of the cryptocephaline division of the family Chrysomelidae from tropical South America: M. Jacoby.—The correlation of certain modifications of the limpet-shell (*Patella vulgata*) with definite environmental conditions: E. S. Russell. The method adopted by the author had been to measure the dimensions of a large number of shells from one environment and to compare them with similar measurements of shells from a second environment. The author had found the limpet a suitable animal for such investigations, as all limpets above 15 mm. "home" accurately. Limpets from high-water localities were found to be larger, broader, and higher, but narrower in proportion than those from low-water localities. Limpets from exposed localities were lower, narrower, thicker, and more irregular in outline than those from sheltered spots. On the area from which the shells were collected two types occurred, a "rough" type with strong coarse ribs and irregular margin, associated with rough stones, and a "smooth" type on polished stones.—Anatomy of the batrachian family Pelobatidae: F. E. Beddard.—The Microlepidoptera of Tenerife: Lord Walsingham.—Dates of publication of the separate parts of Gmelin's edition (thirteenth) of the "Systema Naturæ" of Linnaeus: J. Hopkinson. The paper stated that the first volume of this edition, containing the animal kingdom, was in seven parts, with a date, 1788, in the first part only, but that there was internal evidence of a later date of issue of subsequent parts. Investigations in the library of the British Museum had revealed the years of publication with some indication also of the period of the year in which each part appeared. The dates were:—part i., 1788; parts ii. and iii., 1789; parts iv. and v., 1790; part vi., 1791; part vii., 1792. The second volume, containing the vegetable kingdom, was in two parts, and the date of issue of part ii. had been found to be 1792. Contemporary authorities were given for the dates.—A small collection of Mammalia brought from Liberia by Mr. Leonard Leighton: R. I. Pocock. The paper recorded the presence in Liberia of two mammals hitherto unknown from that locality, and contained descriptions of one species of Genet and one Linsang new to science.

December 10.—Sir Edmund G. Loder, Bt., vice-president, in the chair.—The origin of the mammal-like reptiles: Dr. K. Broom.—A revision of the African silurid fishes of the subfamily *Clariinae*: G. A. Boulenger.—A new species of hæmogregarine from the blood of a Himalayan lizard, *Agama tuberculata*, from Kasauli, India: Prof. E. A. Minchin.

NO. 1991, VOL. 77]

Society of Chemical Industry, December 2.—Mr. R. J. Friswell in the chair.—The estimation of naphthalene in coal gas and spent oxide of iron: C. J. Dickenson-Gair. The methods of estimation described are (1) the acetic acid method; (2) the re-precipitation method.—Note on the influence of formal on the properties of *Funtumia elastica*: Dr. P. Schidrowitz and F. Kaye. The authors find that the rubber obtained from the latex, treated by formal, although less elastic and resilient than that obtained by other means, was extraordinarily tough. They suggest that a rubber of this character might be particularly suitable for some purposes—e.g. for the covers of motor tyres—where toughness is of relatively greater importance than resiliency, and that it may in the future be found desirable to use different methods of coagulation for the same latex according to the purpose for which the rubber is intended.—Polarimetric determination of sucrose: F. Watts and H. A. Tempany. The authors have investigated (1) the effect of basic lead acetate on the optical activity of sugar solutions; (2) the effect of clarification with basic lead acetate on cane juice.—Niam fat: Dr. J. Lewkowitsch. Niam fat was obtained from the seeds of *Lophira alata*, Banks, a tree indigenous to Senegambia, Sierra Leone, and the Egyptian Soudan. The fat, freed from extraneous matter, forms 41 per cent. of the kernels. It is a soft, buttery mass melting at 24° C., and is used by the natives for culinary purposes and as a hair oil.

Entomological Society, December 4.—Mr. C. O. Waterhouse, president, in the chair.—*Exhibits*.—Dr. G. C. Hodgson: A number of examples of *Anthrocca trifolii*, collected on the same ground in Sussex, and showing a wide range of variation, including three fine melanic forms, and several showing six spots on the upper-wings.—W. J. Kaye: A specimen of *Papilio thoas* thoms, with the central portions of both tails removed, apparently by a narrow-billed bird. The injury appeared so symmetrical that it was thought likely that the specimen was an abnormality, but microscopic examination showed that this was not so.—The President: Two photographs of an African locust, which had apparently caught a mouse and was preying upon it. The specimen was found in the Congo State.—R. S. Bagnall: Notes on many species of Coleoptera, Thysanoptera, and Aptera from Northumberland, Durham, and Scotland, of which ten were new to Britain.—L. W. Newman: A long and varied series of *Ennomos autumnaria* (*alnaria*); a series of *Polia xanthomista* (*nigrocincta*), bred from ova and fed on carrot, the specimens unusually large (N. Cornwall); three pairs of hybrid *Notodonta sicca* ♂ × *N. dromedaria* ♀ = *N. newmani*, Tutt; three very fine *Xylina conformis* bred by Evan John, S. Wales; three cocoons (*in situ*) of *Dicranura bicuspis*, collected wild in Tilgate Forest; and a fine melanic ♂ *Oporabia dilatata*, taken wild in Bexley Woods, 1907, this being the first melanic specimen of the species reported from Kent.—Dr. F. A. Dixey: Male and female specimens of a new *Belenos* allied to *B. zochalia*, Boisdu, but quite distinct from the *zochalia* group. These were captured by Mr. Wiggins in the Tiriki Hills, north-east of the Victoria Nyanza.—*Papers*.—(1) The natural enemies of *Bombyx rubi* in Scotland; (2) note in further illustration of the convergence of *Limenitis* (*Basilarchia*) in America: Prof. E. B. Poulton.—The rest attitude of *Hyria auroraria*: J. C. Moulton.—The family tree of moths and butterflies, traced in their organs of sense: A. H. Swinton.—Notes and descriptions of Pterophoridae and Orneoidiæ: E. Meyrick.—Studies on the Blattellæ: R. Shelford.—Notes on the bionomics of British East African butterflies: Rev. K. St. A. Rogers.

Geological Society, December 4.—Sir Archibald Geikie, K.C.B., Sec.R.S., president, in the chair.—The faunal succession in the Carboniferous Limestone (Upper Avonian) of the Midland area (north Derbyshire and north Staffordshire): T. F. Sibly. The area is the periclinal mass at the south end of the Pennine anticline. The series exposed constitutes an expanded development of the Dibunophyllum zone. The most extensive section shows a thickness of 1500 feet. Three subplanal divisions are distinguished:—D₃, subzone of *Cyathoxonia rufiana*; D₂,

subzone of *Lonsdalia floriformis*; D₁, subzone of Dibunophyllum θ . An abnormal development of the Lonsdalia subzone forms a conspicuous local feature in parts of the western area. A local unconformity occurs in the eastern part of the area. A close similarity exists between the Dibunophyllum zone of the Midland area and that of North Wales. A comparison of the Dibunophyllum zone of the Midland with that of the S.W. province brings out important differences:—(a) the brachiopod fauna of the Lonsdalia subzone of the Midland province is richer than that of the equivalent part of the S.W. sequence; (b) the Cyathaxonia subzone of the Midland province is practically undeveloped in the S.W. province.—Brachiopod homomorphy: *Spirifer glaber*: S. S. **Buckman**. The smooth, catagenetic stage of shells may have been attained by the loss of distinctive features, pointing to polygenetic origins. The series of shells figured by Davidson as *Spirifera glabra* do not all agree in being smooth. There is evidence that some forms ranged under this species are Reticularia (McCoy). The use of the generic name *Martinia* for various smooth Spiriferids becomes unjustifiable. The author restricts the genus *Spirifer*, and allocates several British and foreign species among the genera *Fusella*, *Choristites*, *Trigonotreta*, *Brachythyrus*, *Martinia*, and *Reticularia*.

Linnean Society, December 5.—Prof. W. A. Herdman, F.R.S., president, in the chair.—A series of specimens of *Spartina townsendi*, representing different stages of development and tall and dwarf forms, and for comparison also typical specimens of *S. alterniflora* and *S. stricta*: Dr. O. **Stapf**. The specimens of *S. townsendi* and *S. stricta* were collected by the exhibitor in the Isle of Wight; those of *S. alterniflora* near Millbrook Station in Southampton Water.—A collection of plants from Gunung Tahan, Pahang: H. N. **Ridley**.—Report on the Alcyonaria of the Sudanese Red Sea: Prof. J. A. **Thomson** and J. M. **McQueen**. The collection was made in 1906 by Mr. Cyril Crossland, from Suakim, Khor Dongola, and nine other localities, and includes three species of Stolonifera, eighteen of Alcyonacea, one being new, and four of Pseudaxonia.—Report on the Crinoidea of the Sudanese Red Sea: H. C. **Chadwick**. The collection consisted of six species, only two of which had been previously recorded from the Red Sea.—Notes on some marine algae from the Red Sea: Prof. R. J. **Harvey-Gibson**. From material collected by Mr. Cyril Crossland in 1904 and 1905, under the direction of Prof. Herdman, F.R.S. The total number is thirty-five species; twelve belong to the Chlorophyceæ and as many to the Phæophyceæ, with eleven Rhodophyceæ. In an appendix the following phanerogams were mentioned as having been collected at the same time:—*Cymodocea nodosa*, Aschers., *Halophila stipulacea*, Aschers., *Najas major*, All., and fragments of *Salicornia frutescens*, Linn.—Report on the Hydroidea of the Sudanese Red Sea: Miss L. R. **Thornely**.

Mathematical Society, December 12.—Prof. W. Burnside, president, in the chair.—A formula in finite differences and its application to mechanical quadrature: S. T. **Shovelton**.—Weierstrass's E-function in the calculus of variations: A. E. H. **Love**.

Institution of Mining and Metallurgy, December 10.—Prof. William Gowland, president, in the chair.—The assay of telluride ores: G. T. **Holloway** and L. E. B. **Pearse**. The authors have, in view of the difficulty experienced by assayers in the determination of the precious metals in ores containing tellurium and selenium and the discrepancies observable between duplicate assays by different assayers, endeavoured to ascertain how and why, and in which portion of the assay work, the losses occur, and what means should be adopted to prevent them. The possible sources of loss appear to be as follows:—volatilisation during roasting; volatilisation and slag loss in the scorification assay; volatilisation and slag loss in the crucible assay; loss by volatilisation or in the slag in scorifying the lead button obtained in the scorification or crucible assay; or loss by volatilisation and absorption during cupellation. The paper

contains details of a number of actual assays, and gives much valuable information in regard to the methods adopted and the results obtained.—A cheap form of cyanide plant: C. **Hunter**. A description of some cyanide plants of a light and portable nature actually supplied to small mining propositions in Rhodesia, with copies of the contracts and detailed specification. The cost of running such a plant is also stated.—The deep leads of Victoria, or the Cainozoic buried auriferous river deposits: H. L. **Wilkinson**. A review of the buried auriferous gravel deposits occupying the beds of ancient rivers once forming the drainage channels of Victoria at the period when large areas were covered by Pliocene seas. These include the Loddon, Avoca, Campaspe, Smythesdale-Pitfield, Stawell, and Ararat leads and their tributaries, and cover the districts of Ballarat and Bendigo. The author points out the effects of enriching belts in aggregating the rich portions of a lead and other factors determining the quantity of alluvial gold in the wash. At the end of the paper are several pages of tabular matter relating to the working costs of alluvial mines.

CAMBRIDGE.

Philosophical Society, November 11.—Dr. Hobson, president, in the chair.—A critical description of three cases of single hypogastric artery in the human foetus: Dr. **Duckworth**.—The inheritance of white in poultry: R. C. **Punnett**.—Sexual phenomena in the free-living nematodes (preliminary note): F. A. **Potts**. The paper commenced by summarising the work of Maupas, and emphasised the interest and importance of the supplemental males found in the hermaphrodite species. These are chiefly remarkable for their withdrawal from the economy of the species, though in no sense degenerate, or unfitted for reproduction. Confirmation of Maupas's results was drawn from the study of a species of *Diplogaster*; some details of the culture methods used were given, and it was pointed out that this species shows that a race propagating exclusively by self-fertilisation does not of necessity show signs of degeneracy.

November 25.—Dr. Hobson, president, in the chair.—The orientation of 3:5-dichloropyridine: Dr. **Sell**.—The action of metallic magnesium on certain aliphatic acids, and the detection of formic acid: Dr. **Fenton** and H. A. **Sisson**. In a previous communication (Trans. Chem. Soc., 1907, 687) it was shown that both carbonic and formic acids may be reduced by means of metallic magnesium to formaldehyde. Experiments have now been undertaken with the object of ascertaining whether an analogous reduction can be effected in other acids, and the results so far obtained appear to indicate that this is only possible in the lower members of a series. Further, it is shown that this reduction by means of magnesium affords a characteristic and fairly delicate test for formic acid, the special reactions for formaldehyde being of a far more positive character than those for formic acid.—Some colour-reactions of organic acids with phenols: Dr. **Fenton** and G. **Barr**. Remarkably brilliant colour-reactions are often obtained when certain organic acids are treated with phenolic compounds in presence of strong sulphuric acid, and it appeared desirable to tabulate the results obtained with some of the less common acids in order to ascertain whether the reactions might be employed for the purpose of preliminary identification. By comparing the colours obtained in this way with two or more phenols, information of a positive character may often be obtained. The method has the advantage of being applicable, not only to the acids themselves, but also to their salts or esters, and is useful for provisional identification when only minute quantities of the substance are available.—Contributions to the knowledge of the oxaloimidochlorides: S. **Ruhemann**.—The absorption spectra of collidine and η -chlorocollidine: J. E. **Purvis** and W. H. **Foster**. The curve obtained from a study of collidine showed that it was very similar to that of pyridine and lutidine previously studied by Hartley and by Baker and Baly. The differences were that there was a slight shift of the band towards the red end of the spectrum, and also that the persistence of the band was decreased a little less than that of lutidine and pyridine.—The decomposition and nitrification of

sewage (1) in alkaline solution, (2) in distilled water: J. E. Purvis and R. M. Courtauld. The results showed that after incubations extending over eight weeks there were only small quantities of nitrates produced; also that (1) there were smaller quantities of nitrates produced in the alkaline solution than in the non-alkaline; (2) a larger comparative increase of the free ammonia in the alkaline than in the non-alkaline solution; and (3) a progressive diminution in the total ammonias.—The influence of light and of copper on fermentation: J. E. Purvis and W. A. R. Wiks. The results showed that fermentation under sterilised and non-sterilised conditions in glass vessels under the influence of various spectral colours, as well as of white light, was not very seriously influenced. The most marked effects were in differences in the acidities of the fermented wort; the fermentations under the influence of red rays were more acid than those in the white light, but the differences in the numbers obtained from the optical activities were not sufficiently marked to draw definite conclusions. The influence of copper on the fermentation was very marked. Very small quantities were sufficient to cause great differences in the numbers obtained from the optical activity, the copper oxide reducing power, the attenuation, and the acidity.—Resolution of optically active ammonium salts by means of tartaric acid: H. O. Jones.—Studies on platinumocyanides: L. A. Levy. The crystals of barium platinumocyanide may be obtained in two forms, which exhibit a great difference in physical properties—notably in their fluorescence and colour. The present communication contains an account of the author's experiments on the nature of the two varieties and the fluorescence exhibited by them.—Orientation of substituted bromoanilines: J. R. Hill.—The solutions of ordinary linear differential equations having doubly periodic coefficients: J. Mercer.

DUBLIN.

Royal Dublin Society, November 19.—Prof. Sydney Young, F.R.S., in the chair.—The synthesis of glycosides: some derivatives of xylose: H. Ryan and G. Ebrill. By the action of acetyl chloride on xylose in a sealed tube acetyl-chloroxylose was obtained. The substance, which crystallised well, melted at 101° C. From it the xylosides of α -naphthol and carvacrol, and the tetracetyl derivative of xylose were prepared. β -Naphthyl-xyloside was formed by addition of acetyl-chloroxylose to a solution of potash and α -naphthol in absolute alcohol. It crystallises in long needles, which melt at 192° C. to 193° C. The substance is soluble in alcohol, acetone, and acetic ester, and almost insoluble in ether, carbon bisulphide, chloroform, and petroleum ether. It does not reduce Fehling's solution. Emulsion has no action on it. In a similar manner acetyl-chloroxylose was converted into carvacryl-xyloside. The latter substance crystallises in needles, which are soluble in alcohol, ether, chloroform, acetic ester, and acetone, but are insoluble in carbon bisulphide. Its melting point is 105° C. Like the corresponding α -naphthyl compound, it reduces Fehling's solution only after inversion by hot dilute acids. Tetracetyl-xylose, which was obtained by the action of silver acetate on acetyl-chloroxylose, is a crystalline solid which melts at 110° C. (uncorr.).—The radio-activity of sea-water: J. Joly. Examination of five samples of sea-water from various points round the Irish coast seems to show that when care is taken not to precipitate the radium in a non-emitting form when concentrating by evaporation (and for this purpose it is necessary to add a few c.c. of pure HCl when evaporating), the quantity of radium found is much greater than has been ascribed to sea-water hitherto. The larger values found may be in part due to suspended coastal materials. Experiments on mid-ocean waters are in progress.

MANCHESTER.

Literary and Philosophical Society, October 29.—Prof. H. B. Dixon, F.R.S., president, in the chair.—The atomic weight of radium: Dr. H. Wilde.—The production and origin of radium: Prof. E. Rutherford. An account was given of the historical development of our ideas in

regard to radium. On the disintegration theory, radium is regarded as a substance undergoing slow spontaneous transformation with a period of about 2000 years. In order to account for the existence of radium in minerals of great age, it is necessary to suppose that radium is produced from another substance of long period of transformation. There is a genetic connection between uranium and radium, for investigation has shown that the amount of radium in minerals is in all cases proportional to their content of uranium. If this be the case, radium should gradually appear in a preparation of uranium, initially freed from radium. No such growth of radium has been observed over a period of several years, although a very minute growth of radium can be easily detected. This is not necessarily inconsistent with the disintegration theory, for if one or more products of slow transformation exist between uranium and radium, no appreciable growth of the latter is to be expected in a short interval. A search for this intermediate product has recently proved successful. Boltwood found that a preparation of actinium, initially freed from radium, grew radium at a constant and rapid rate. Boltwood at first considered that actinium was this intermediate product, and that actinium changed directly into radium. The growth of radium in actinium solutions was confirmed by the author, who had commenced experiments in that direction three years before. The experiments showed, however, that actinium did not, as Boltwood supposed, change directly into radium. By a special method, a preparation of actinium was obtained by the author which showed no appreciable growth of radium over a period of 240 days. The growth of radium, if it occurred at all, was certainly less than 1/500th of that ordinarily observed. In another case, a solution of actinium was obtained which produced radium faster than the normal. These results are completely explained by supposing that a new substance of slow transformation is present with actinium, and this substance is transformed directly into radium. This parent of radium has distinct chemical properties, which allow it to be separated from both actinium and radium. The absence of growth of radium observed in the actinium solution mentioned above is due to the fact that, by the special method, the parent of radium had been completely separated from the actinium. In recent letters to NATURE, Boltwood confirmed the results of the author, and described a satisfactory method of separating the radium parent from actinium. He has shown that this new body, which he proposes to call "ionium," gives out α and β rays, and has the chemical properties of thorium. The Royal Society recently loaned the author the actinium residues from about a ton of pitchblende. These residues contain the parent of radium, and experiments are in progress to isolate and concentrate both the actinium and ionium in these residues.

November 12.—Prof. H. B. Dixon, F.R.S., president, in the chair.—(1) The cone of *Bothrodendron mundum* (Will.); (2) on the ulodendroid scar: D. M. S. Watson. In the former it was pointed out that the small hermaphrodite lycopodiaceous cone described by Williamson in part x. of his series of monographs on the organisation of the fossil plants of the Coal-measures had an axis which agreed very closely with the wood of a small stem of *Bothrodendron mundum*. On the evidence of the characters of the axis and of the sporophylls, supported by constant association of the cone or its characteristic megasporangia with stems of *Bothrodendron mundum*, it was concluded that the cone in question was really that of *Bothrodendron mundum*. In the paper on the ulodendroid scar, the theory that ulodendroid scars were produced by the pressure of the bases of sessile cones was shown to present difficulties, e.g. cones large enough to have produced scars 6 inches in diameter were unknown, and it was difficult to see how the scars would have grown appreciably without becoming wider laterally than vertically, which was never the case. It was shown that all the ordinary features of a ulodendroid scar could be explained on the theory that it represented the base of a branch attached to the whole area of the scar.

NEW SOUTH WALES.

Linnean Society, September 25.—Mr. J. H. Maiden, vice-president, in the chair.—The genus *Petalura*, with description of a new species (*Neuroptera*: *Odonata*): R. J. Tillyard. This remarkable isolated genus is probably a relic of an ancient Australian odonate fauna, which is now being steadily displaced by an Asiatic invasion. *P. gigantea*, Leach, occurs round Sydney and on the Blue Mountains, and was described nearly a hundred years ago. It is about $\frac{1}{2}$ inches across the wings. The new species, *P. ingentissima*, is found in northern Queensland. It is the largest dragon-fly known to exist at present (about 6 inches across the wings), and seems to show connection with the huge Tertiary Gomphinae which have been found in a fossil state. It is exceedingly rare, and becoming obsolete; the only two specimens known are the types.—The dragon-flies of south-western Australia: R. J. Tillyard. The district worked was that lying between Perth on the north and Cape Leeuwin on the south, which has a regular and abundant rainfall. It may be divided into two portions, the Darling Ranges with their running streams, and the low coastal strip with lagoons and marshes. The *Odonata* of the two portions were found to be very distinct. Twenty-six species were noted, of which six are new and very interesting forms (referable to the genera *Synthemis* [2], *Austrogomphus*, *Austroæschna*, *Argiolestes*, and *Pseudagrion*); four or five others are very rare, and the rest are common eastern species. Many of the species are black or nearly so, and seek protection on the burnt stumps or in the foliage of the "black-boys" (*Xanthorrhoea*), which are abundant everywhere.—Note on a glaucophanne schist from the Conandale Range, Queensland: H. I. Jensen.—Chemical note on recent lava from Savaii: H. I. Jensen.—Revision of Australian *Lepidoptera*, part iv.: Dr. A. J. Turner. This paper continues the revision of the family *Geometridæ*, and is mainly concerned with the subfamily *Sterrhinae*. When Mr. Meyrick revised this group in 1887, he recognised thirty-two species, referred to five genera; the present revision treats of one hundred and two species, ascribed to twenty genera. Five species, referable to the subfamily *Hydriomeninae* (dealt with in the preceding paper), are also described as new.

October 30.—Mr. A. H. Lucas, president, in the chair.—The Tertiary limestones and foraminiferal tuffs of Malekula, New Hebrides: F. Chapman. These rocks form part of the collection made by Mr. D. Mawson in 1903. The paper deals with the Miocene and the post-Miocene rocks of Malekula, south of Santo. Trillina has been found to occur in the New Hebrides; this genus has already been proved to exist in South Australia and the Philippines, which thereby connects the south coast of Australia with the islands of east Australasia and portions of the East Indian Archipelago, along which line in Oligocene times there probably existed a shallow-water area where such forms could flourish. A new species of *Alveolina* found in the Malekula limestone had already been figured from Javan Miocene limestones. *Lepidocyclus angularis*, found at Malekula, and already known from Miocene limestone in the Loo-Choo Islands, off Japan, shows a further extension of the Miocene shore-line as far north as Japan.—A collection of dragon-flies from Central Australia, with descriptions of new species: R. J. Tillyard. The collection was made by Mr. J. F. Field, and is probably typical of the odonate fauna of Central Australia. Though well within the tropics, yet the locality exhibits no definite tropical forms. The 320 specimens examined comprise ten species; eight are common over Australia, two are new. One, *Lestes aridus*, is allied to *L. leda* and *L. analis*; the other, *Austrosticta Fieldi*, is the type of a new genus.—Memoir on a few heteropterous Hemiptera from eastern Australia: G. W. Kirkaldy. This memoir records the Heteroptera collected by Mr. A. Koebele and Dr. R. C. L. Perkins in Queensland, and by Mr. Koebele in New South Wales. Seven genera and twenty-five species are proposed as new.—The geographical significance of floods, with especial reference to glacial action: E. C. Andrews. The forms of roadside gutters and of miniature cañons admit of explanation, since the

time occupied in their formation falls within decades. Storm-formed cañons show, in the initial stages, spurless trenches U-shaped in cross-section, the trench bases possessing deep basins. At a later stage these cañons show double slopes, the upper V-shaped, the base U-shaped, in cross-section. This lower contour represents the flood contour. In river valleys, along shore-lines, and in glacial cañons, forms similar to these occur. Along miniature cañons generally the flood alone does the corrosive work. The application of such truths to glacial cañons explains drumlin forms and other apparent anomalies.—Solandrine, a new midriatic alkaloid: Dr. J. M. Petrie. The alkaloid belongs to the atropine group, and resembles hyoscyne. It differs from hyoscyne in its aurochloride in not reddening phenolphthalein, and it yields atropine instead of tropic acid when hydrolysed. Though the exact constitution of the alkaloid has not been worked out, the results afford evidence of the existence of a tropine alkaloid in *Solandra laevis*, for which the name solandrine is proposed.—Description d'une nouvelle Espèce d'Oxylemus (*Coleoptera*: *Colydiidae*): A. Grouvelle.

CONTENTS.

PAGE

Electric Traction. By Gisbert Kapp	169
Veterinary Anatomy	170
The Romance of Savage Life	171
Our Book Shelf:—	
Diels: "Die Vegetation der Erde"	171
Schaffer: "Das inneralpine Becken der Umgebung von Wien."—G. A. J. C.	172
"The British Journal Photographic Almanac and Photographer's Daily Companion for 1908"	172
Readymoney: "Science of Nature-History"	172
Orage: "Nietzsche in Outline and Aphorism"	173
Letters to the Editor:—	
The Photoelectric Property of Selenium.—Prof. George M. Minchin, F.R.S.	173
Early Chinese Description of the Leaf-Insects.—Kumagusu Minakata	173
The Salmon. (<i>Illustrated</i>),	173
Entomology for the Young. (<i>Illustrated</i>) By Fred. V. Theobald	175
Lord Kelvin. By Prof. Silvanus P. Thompson, F.R.S.	175
Lord Kelvin's Funeral in Westminster Abbey	177
Notes	179
Our Astronomical Column:—	
Nova Persei, 1901	182
Provisional Elements for the Spectroscopic Binary α Andromedæ	182
Photographs of Mars	182
Saturn apparently without Rings	182
Prizes Proposed by the Paris Academy of Sciences for 1909	183
Recent Work of Geological Surveys. (<i>Illustrated</i>) By G. A. J. C.	183
Archæology in America. By H. R. Hall	186
The Pelycosaurian Reptiles. By R. L.	186
University and Educational Intelligence	187
Societies and Academies	187

THURSDAY, JANUARY 2, 1908.

THE INHERITANCE OF "ACQUIRED" CHARACTERS.

Sur la Transmissibilité de Caractères acquis. By Eugenio Rignano. Pp. 320. (Paris: F. Alcan, 1906.) Price 5 francs.

A MAN of science to command general attention and interest must do two things; first, he must make interesting discoveries or profound generalisations; and, secondly, he must do these things at the right time. Darwin made his name because he fulfilled both these conditions. Mendel died an unknown man because he did not fulfil the second. He was forty years too soon. Supposing that Mendel's paper had been completely lost sight of, as it actually was for thirty-five years, and very nearly was altogether, his results must, sooner or later, have been obtained by somebody else, who would then have won the laurels which now belong to Mendel, not because he made a greater discovery than Mendel, but because he made it at a time when the state of biological thought was such that it could appreciate the significance of the discovery.

If it is possibly fatal to make discoveries too soon, it is certainly fatal to make them too late. It is therefore with a certain sense of weariness, mingled with surprise, that we note the appearance of a work on the transmission of acquired characters. Lamarck's theory of evolution involved a belief in the thesis that acquired characters are transmitted. Darwin believed that evolution was due to the natural selection of both innate and acquired characters, and his theory of pangenesis was more than anything else an attempt (shirked by Lamarck) to provide a hypothesis to account for the transmission of acquirements. Darwin's suggestion that innate characters played a part in evolution as well as acquired ones paved the way for the great step taken by Weismann, who in his theory of the continuity of the germ-plasm laid the foundation of the modern, and still infant, science of heredity by doing away with the transmission of acquirements once and for all.

The step taken by Weismann is far and away the most important in the history of evolution, or at any rate of genetics, because it divides that history into two periods, in the first of which the problem to be solved was: "How do the characters of an organism get into the germ-cell which it produces?" whilst in the second the problem has become: "How are the characters of an organism represented in the germ-cell which produces it?"

Weismann showed that the problem of the first period was as unreal as the question about the apple dumpling which puzzled one of the Georges, by opening our eyes to the fact that the characters of an organism do not get into its germ-cells any more than the apple gets into its crust, but that both the germ-cells and the apple were there all the time.

Darwin, although he made a great step in advance of Lamarck by elaborating a theory of evolution which did not rest solely or even largely on the transmission

of acquirements, did not go to the length of throwing that theory overboard altogether. It was left for Weismann to do this and thereby rid biology of a belief which has been the occasion of more futile discussion than any other that can be named. The full significance of Weismann's action is seldom appreciated, and cannot be done justice to here, but it is not too much to say that without it the problem of heredity would have been doomed to insolubility, and, to take a concrete example, that the Mendelian work of the last seven years would have been impossible.

Whether it is due to the general truth that a view once widely held is difficult to stamp out, or whether it is that there is something peculiarly fascinating in the belief that acquired characters are transmitted, the fact remains that there are still to be found isolated biologists and whole hosts of medical men who still hold it. However, as a belief in teleology, though rare, still exists, we perhaps ought not to be surprised at anything.

The author of the book before us, who is an engineer interested in sociology, believes in the transmission of acquirements, and has invented a theory of centro-epigenesis to account for the phenomenon. If the book is read it must be read in conjunction with the appendix dealing with this topic in Mr. Archdall Reid's "Principles of Heredity," and with Weismann's "Deszendenztheorie," which has been translated into English by Prof. J. Arthur Thomson.

A. D. D.

PROBLEMS OF VISION.

Zur vergleichenden Physiologie des Gesichtssinnes.

By Prof. E. Raehmann. Pp. iv+58. (Jena: G. Fischer.) Price 1.50 marks.

THIS short pamphlet contains a discussion of three interesting problems in vision. It has long been known that the arrangement of the retinal elements in regard to the light falling upon the eye is reversed in the vertebrata and some invertebrates as compared with the majority of the latter. The author wishes to direct attention to the problem of explaining how in these "inverted eyes" the stimulus of light affects the retina. He puts forward the view that the morphologically outer end of the rods and cones acts in these cases as a reflector, and causes the light to re-enter the inner limb where the visual stimulus commences. In that sense, therefore, the vertebrate retina is no exception to the general statement that the rods always face the effective light rays. The isolation of the rods by pigment leads the author to an interesting account of the various forms of iris and of retinal pigments.

The second problem is the function of the tapetum. The significance of this brilliant structure has received little attention. Hatschek has attempted to show that it reinforces the incident light. The author, however, proceeds to show that the incident light is not effective even partially, but that it is the rays reflected from the concave and asymmetrical tapetal mirror which illuminate the inner portion of the peripheral retina. This area, weak in perception of detail, but

strong in detection of movement, catches the images of objects moving laterally. The tapetum would thus be put out of action by "blinkers," and, on the other hand, would aid carnivores both by detecting movements of their prey and by bringing these movements to the analysis of the central vision.

The third problem discussed in this pamphlet is that of colour-vision amongst insects. Insects are chosen because there seem good *a priori* grounds for believing that they possess colour-perception. The problem is raised in this form: Is any morphological peculiarity in the structure of these presumably colour-perceptive animals associated with this faculty, and can we picture their colour-field? The author points out the well-known composite nature of the rhabdoms or rods in the higher crustacea and insects, how they are composed of denser and more refractive plates alternating with feebly refracting layers, and how white light becomes broken up, partially absorbed and partially resolved into interference colours. He concludes that diurnal insects must view objects as we should see them through a tinted glass. Those coloured with the like tint would stand out from the rest, the majority would be blurred, and the whole field would be dim in any but a strong light. Hence, the author infers, the activity of diurnal lepidoptera only in very bright weather. Some of the suggestions made in this speculative essay are of great interest. Allied species often exhibit very different choice of stations, and comparison of their eyes may throw some light on why they do so. Again, the form of the rods of diurnal insects is certainly broadly different from that of nocturnal insects; the former are clear, the latter suffused with red pigment. But, on the other hand, both kinds of insect-eye show a similar lamellar structure, and it would require a far more rigid demonstration than is given by the author of this work before we could accept the view he takes, fascinating and suggestive as it is.

A LANCASHIRE FLORA.

The Flora of West Lancashire. By J. A. Wheldon and A. A. Wilson. Pp. iii + 511. (Liverpool: J. A. Wheldon, 60 Hornby Road, Walton; Ilkley: A. Wilson, 4 Eaton Road, 1907.) Price 12s. 6d.

WHEN the ravages of the jerry-builder are fast obliterating the comparative solitudes on the outskirts of our great cities, and the equally destructive, though more localised, irruptions caused by dock and railway extensions and industrial enterprises are slowly exterminating the flora of our countryside, it is a matter for congratulation that there are to be found men like the authors of this flora, prepared to sacrifice hours of leisure and recreation in the task of cataloguing for future reference the plant inhabitants of such botanically doomed districts. As the authors point out, Lancashire is sadly deficient in such records, and the present result of their painstaking efforts is to be welcomed for that reason, if for no other.

The volume is, in the main, a catalogue of the plants of the district known in Watson's "Topographical Botany" as "Vice-County No. 60," em-

bracing the West Lancashire spurs of the Pennines, the coast district between Carnforth, Morecambe and Lancaster, and the extensive flat lands reaching from the estuary of the Lune to that of the Ribble. The catalogue is prefaced by a summary of the general topographical and botanical features of the district, by a chapter on meteorology and climate, and a brief synopsis of the relation of plant distribution to latitude and to edaphic factors. The flora follows, as the authors say in their preface, "the conventional models," yet one could have wished that they had departed from these models—at least in a few fundamental particulars.

One of the most remarkable features of recent British floras is the inclusion of gymnosperms under the head of dicotyledons. It is incomprehensible to the general botanist that a taxonomy so archaic should be repeated so persistently in successive editions of the London catalogue, in local floras like the present, and even in the latest list of British plants compiled by Britten and Rendle.

Again, the value of this flora would have been greatly enhanced had the authors deemed it advisable to add some critical notes on local forms and varieties special to the district, on the model of Townsend's excellent flora of Hampshire.

Although they do not profess to give "a botanical survey" of the West Lancashire area, the authors have devoted nearly a quarter of the volume to what is to all intents and purposes a digest of that aspect of their subject—to the general reader by far the most interesting part of the book. Moreover, this section is illustrated by fifteen most excellent photographs, of characteristic ecological features. One does not wish to depreciate the value of records of "first finds," nor the claim to recognition of the "first finders," but there remains a lingering desire for a more succinct treatment of such records—which, after all, can be only of local interest—and a fuller statement of the main general topographical features, a statement which the authors are, apparently, so well qualified to give.

It has been customary, for some unexplained reason, to include in local (and even general British) floras only dicotyledons (including—saving the mark! Coniferæ), monocotyledons, Pteridophyta and Characæ. Messrs. Wheldon and Wilson have had the courage to include mosses, Hepaticæ and lichens, on which groups, if we mistake not, one at least of the writers is an acknowledged authority. It is unfortunate that they have not been able to enlist the aid of a fungologist and algologist, and so present us with a *complete* flora of the area.

It seems almost ungracious to direct attention to the many typographical errors, especially in the first quarter of the volume (over and above the few errata mentioned), and, too, the haphazard distribution of commas and full stops, authorities for species, and so on, but these criticisms are made with no intention of depreciating the merits of the work under review, but rather of indicating what we think are deficiencies and blemishes on what is otherwise a valuable contribution to the field botany of a hitherto neglected district.

SELENOLOGY AND GENERAL ASTRONOMY.

- (1) *The Moon in Modern Astronomy.* By Ph. Fauth, translated by Joseph McCabe, with an introduction by J. E. Gore. Pp. 160; illustrated. (London: A. Owen and Co., n.d.) Price 10s. net.
- (2) *Astronomical Essays, Historical and Descriptive.* By J. Ellard Gore. Pp. viii+342; illustrated. (London: Chatto and Windus, 1907.) Price 6s.
- (3) *Evolution of Planets.* By Edwin G. Camp. Pp. 166. (Ist. net: T. Thatcher, College Green, 1907.) Price 1s. net.

THIS volume contains Mr. Fauth's summary of his twenty years' selenographic work, together with a discussion of the many problems which face the selenographer of to-day. Mr. Gore's introduction is purely descriptive of the general classification of lunar features, of which he defines the general terms, thus enabling the non-astronomical reader to study Mr. Fauth's work with some measure of understanding.

The theme of the work is the substantiation of the author's conclusion that our satellite is covered with a thick layer of ice. Both the "meteoritic-bombardment" and the "plutonic" theories of selenological evolution are critically examined, and their fallacies exposed. In the first chapter the author gives an interesting historical survey of selenology from early Grecian times to the present, paying special attention to the various maps which have from time to time been published. In this connection he rather depreciates the possibility of photographs, even of the excellence now attained, being as efficient as the eye in delineating the fainter shades of difference to be found in the lunar landscape.

The second chapter discusses appearance and reality, going into details as to what can really be seen with certainty, and as to the best means to employ for selenographical work. The essential differences between terrestrial volcanic craters and the so-called "craters" of the moon are emphasised strongly, and this leads to the discussion of the terminology generally adopted by selenologists.

Under the headings "Light and Colour," "The Ring Mountains," and "The Remaining Elevations and the Rills" respectively, the next three chapters are devoted to a critical examination of the various lunar features, showing how the results obtained by an experienced observer are incompatible with the older theories of lunar evolution. In the next, and concluding, chapter (vi) we are introduced to the theory which, in Herr Fauth's opinion, best explains the multitudinous appearances seen on the moon, viz., "the moon is covered with a thick layer of ice." This conclusion is not a novel one, but it probably has never been so ardently advocated as in the present volume. Probably our satellite obtained the thick coating of solid H₂O, around its globular nucleus, by accretion from the intensely cold depths of outer space; possibly minor meteoric bombardments occasioned the breaches through which the sub-glacial, warmer water was expressed and formed the "seas," the "walled plains," &c., which now make up the

lunar surface. On this theory the author is able to explain the large number of lunar objects which twenty years of devoted study have revealed to him, and he promises in a future work to establish it further. In conclusion, he subjects to severe criticism the records of recent changes in certain lunar formations, and expresses his conviction "that no eye has ever seen a physical change in the plastic features of the moon's surface."

(2) Nine of the twenty-four essays in this volume have previously appeared in various astronomical journals; the others are now published for the first time. The range of subjects is extensive, including such items as "Primitive Astronomy" and "Modern Theories," "The Ringed Planet," and "The Stellar Universe," "The Names of the Stars," and "The Size of Stellar Systems," &c.

As all those who are acquainted with Mr. Gore's writings would expect, all the essays are very interesting and instructive, but some will probably attract more general attention than others. For example, Mr. Gore gives a most interesting account of Michell, a divine of the eighteenth century, who, amongst other matters, discussed the probable parallax and magnitude of the fixed stars in an original and suggestive manner, extensively justified by more recent researches, and who seems to have been lost sight of in the blaze of glory which attended his immediate successor, Sir William Herschel. The theories and observations of the latter are also discussed in the light of recent knowledge, in a style that cannot fail to interest even the general reader.

The essays on the light, the secular variation, the number, and the brightness and density of the stars are more of the general style, but, as treated by Mr. Gore, are certain to attract and maintain the reader's attention.

"A Possible Celestial Catastrophe," involving an illuminating discussion of the subject of dark bodies in space, and "The New Cosmogony," in which the "planetesimal hypothesis" is expounded, are typical of the more speculative essays, and here again the problems are clearly stated and judiciously examined.

Generally speaking, Mr. Gore employs data which have accrued from the most recent investigations, and the value of the volume is enhanced by six reproductions from actual photographs taken by Profs. Barnard and Wolf, and the late Dr. Roberts.

(3) It is difficult to see what useful purpose this posthumous publication of Mr. Camp's notes will serve. The author, in respect to accepted scientific theories, was a confirmed iconoclast, and treated dogma with scant ceremony. Yet we find the following on p. 35:—

"That the earth is a cool, hollow sphere may have been inferred by many minds, but it has not yet been taught as a matter of fact. Such, however, it is, and such it can be proved to be."

Similarly, all the planets, and the sun, are hollow spheres, coal is not compressed vegetable matter, the interior heat of the earth's crust is caused by the friction between magnetic currents as they come in

contact with each other and with non-conducting material; and so the book proceeds throughout its four hundred and sixty-seven disjointed articles, which were originally written as "Ideas from Port Shepstone" for the *Natal Mercury*.

W. E. ROLSTON.

OUR BOOK SHELF.

The Climber's Pocket Book. Rock-Climbing Accidents, with Hints on First Aid to the Injured, some Uses of the Rope, Methods of Rescue and Transport. By Lionel F. West. Pp. 79; illustrated. (Manchester: The Scientific Publishing Co., n.d.) Price 2s. 6d. net.

ACCIDENTS are possible even to the most careful climbers, and they may happen in places from which a disabled man cannot readily be extricated. In such a case Mr. West's handy little book will be of the highest value, for his directions are terse, clear, and adapted to the various circumstances in which a mishap may be critical—on the face of a cliff, in a narrow gully or "chimney," when crags have to be climbed, or narrow ledges traversed before reaching a position which is easy of access. He explains and illustrates by photographs the different modes of using the rope, and how, by means of it, the disabled man may be lowered down precipitous rocks, transported across snow slopes, and carried on a stretcher, readily improvised, when the going becomes easy.

We are also told the symptoms indicating the nature of an injury, what to do and what to avoid, the articles of general equipment, and the few simple medicines and appliances which a climbing party should carry with them. That party, Mr. West rightly declares, should not number less than three; four is better, but more than that on a rope much retards progress, and the climbers in front, especially if the party be divided, may dislodge stones which imperil those in the rear.

If a man chooses to climb alone he must take the risks, for a simple fracture may then mean a lingering death; and two are not enough, for if assistance be needed the injured man must be left to pass hours, perhaps a night, in solitude. Frostbite, snow-blindness, and mountain sickness are described, with instructions for treating them, and Mr. West gives some valuable hints on the best way of avoiding mountain dangers, with a chapter of "don'ts," of which we must be content to say that, were it more generally followed, accidents would be far less frequent.

What Rome was Built With. A Description of the Stones employed in Ancient Times for its Building and Decoration. By Mary Winckles Porter. Pp. viii+108. (London and Oxford: Henry Frowde.) Price 3s. 6d. net.

EVERY intelligent visitor to Rome feels more or less curiosity about the varied stones that were used in such profusion for purposes of construction and decoration. Ordinary guides and guide-books are prone to err in the identification of the stones, and still more in any attempt to trace their origin or explain their formation. To deal adequately with the subject needs, in truth, the knowledge of both antiquary and geologist. The writer of this work, without professing any originality, has carefully collected from both sources a great deal of interesting information, and has examined critically several collections of typical specimens, with the result that she has produced a little volume that ought to be decidedly helpful to the inquirer.

The nomenclature of the ornamental stones employed by the ancients is often perplexing, leading occasionally to downright error. Even so common a term as "alabaster" is apt to be a source of some confusion, inasmuch as it is applied to both the carbonate and the sulphate of lime. Still more confusing is the use of the word "serpentine," for the antiquary often applies it to the green porphyry of Greece, a material very similar to the well-known rock of Lambay Island, near Dublin. On such points of terminology, as on other matters, the writer may be safely trusted, for her quotations show that she has not failed to consult the highest authorities.

A list of works of reference is appended, but its usefulness would have been increased if the dates of publication had been generally given. In the few cases where dates are quoted, accuracy is not always conspicuous. Thus a paper by R. Swan on Paros is here cited as having been read at the British Association in 1877, whereas on p. 83 the date is given as 1887; but, as a matter of fact, neither is correct, for the paper was read in 1889, and in Section C, not G, as here stated. A little more care might also have been well spent in the arrangement of the matter. What can be the use of explaining the meaning of the word "breccia" in a note on p. 50 when it has already been explained in words almost identical on p. 37? But these are only trifling blemishes, which detract but little from the value of an interesting compilation. It is difficult to point to any other work on the subject equally convenient and trustworthy.

Nature's Hygiene and Sanitary Chemistry. By C. T. Kingzett. Fifth edition. Pp. xvi+527. (London: Baillière, Tyndall and Cox, 1907.) Price 7s. 6d. net.

THIS is a book written with a purpose, and the purpose is to proclaim the virtues of a certain disinfectant in which the author is interested. There is no secret about the matter; he shows us the axe he is grinding, and every now and then holds it up, as it were, that we may admire the nice sharp edge he is putting on the implement.

By "Nature's Hygiene" the author means the process of oxidation, as shown more especially in the absorption of moist atmospheric oxygen by certain terpenes, with the concurrent production of hydrogen peroxide and oxidised terpenes. Enormous quantities of these substances arise in forests; the peroxide destroys decaying vegetable matter, and the terpene-products act, in the author's view, as antiseptics.

The early chapters of the book deal with elementary chemistry, and lead up to the consideration of ventilation, fermentation, putrefaction, water supply, and the treatment of sewage. Thence we pass to theories of disease, and so on to the question of disinfection. Remembering that the author is writing for people who are presumed to be ignorant even of very elementary science, we may say, without endorsing all his opinions, that he gives an interesting and readable sketch of the various matters dealt with. It is marred, however, by vain repetitions; thus the author's views upon the question of whether microorganisms or their toxins are the *causa causans* of disease crop up about as often as King Charles's head did in the writings of Mr. Dick. Moreover, much of the book is ancient history; the footnotes teem with references to obsolescent matters dating back to the '70's and '80's of last century, whereas modern results are sometimes overlooked. Thus, although there are some notes upon argon and electrons, radium and radiobi, yet when we turn to the chapter on malarial fever to learn what our author has to say about the

work of Ross, Grassi, and others during the last few years, we find him talking of *Eucalyptus globulus*, and telling us that "Laveran and others claim that the disease is produced by certain microorganisms allied to the Flagellata, but this is contested by Tommasi-Crudeli." Certainly this is a book that requires to be read with discrimination. C. S.

Étude sur les Foudroiements d'arbres constatés en Belgique pendant les Années 1884-1906. By E. Vanderlinden. Pp. 79. (Bruxelles: L'Observatoire Royal de Belgique, 1907.)

A PHENOMENON of very frequent occurrence, and one that has been much studied, is the injury occasioned to trees by lightning, and yet we have no satisfactory explanation of the many difficulties that the problem presents. It must be admitted that these inquiries have not always been pursued on scientific lines, and the facts that have been collected and the theories that have been suggested need a thorough sifting and examination: This is the task to which M. Vanderlinden has applied himself with very considerable success. If he has not satisfied curiosity in all directions, he has at least overthrown some popular errors, limiting and indicating the field of strictly useful inquiry.

It has long been held that some trees are not liable to be struck by lightning. M. Vanderlinden examines this assertion, and finds that in Europe no kind of tree is free from this damage. Some kinds, such as the oak, the poplar, and some species of fir, are more frequently injured than others, but there are not sufficient data to show how far this result is effected by situation, by size, by exposure, or by the greater number cultivated. The causes which may be expected to influence the selective power of lightning are also investigated, but with only negative results. Among these we find the character of the soil, the chemical constitution of the timber, the proximity of water surface, the formation of the leaf, the shape of the tree, and particularly the character of the bark. In this last, the author thinks that possibly we have a source of explanation that has not been sufficiently examined. Trees possessing a smooth bark, such as beeches, are less liable to be struck than those having irregular, rugged, roughened surfaces, the external portions of which, becoming dry and dead, are bad conductors of electricity.

Other questions discussed are the manner in which lightning affects the tree, the character of the so-called spiral injuries, the actual combustion of the tree material, and the manner in which men and animals suffer injury when in the neighbourhood of trees that have been struck. The whole forms an admirable examination of a very scattered literature, and accurately exhibits the present position of an unexhausted inquiry. Detailed tables accompany the paper giving information concerning the locality, the number, and variety of trees, reported as being struck by lightning in the years under review.

The Laws of Health, A Handbook on School Hygiene. By Dr. Carstairs G. Douglas. Pp. vii+240. (London: Blackie and Son, Ltd., 1907.) Price 3s. net.

THIS should prove a useful book for school teachers and others interested in the important subject of school hygiene. Anatomical and physiological details are briefly dealt with, as the author justly remarks that there are several excellent manuals dealing with these subjects. On the other hand, the really important and fundamental portions of hygiene as applied to school life, such as ventilation, warming and lighting, and the fittings of the school buildings, the nutrition, ailments and deformities of the pupils, are discussed with sufficient fullness, and these sections are copiously

illustrated with diagrams and drawings. In dealing with fatigue, we are glad to see the stress the author lays on a proper amount of sleep, and that he ascribes a good deal of the listlessness and inattention, &c., met with in public elementary schools to deficient sleep. We have nothing but praise for the chapters on the slight ailments of children, the eye and ear, and infectious diseases; even the "fourth disease" is referred to. The only omission we have noted is a reference to the cleansing and periodical disinfection of school premises. R. T. H.

LETTERS TO THE EDITOR.

[The Editor does not hold himself responsible for opinions expressed by his correspondents. Neither can he undertake to return, or to correspond with the writers of, rejected manuscripts intended for this or any other part of NATURE. No notice is taken of anonymous communications.]

The Wehnelt Kathode in a High Vacuum.

THE interesting experiments on the Wehnelt kathode in a high vacuum described by Mr. Soddy in NATURE for November 21, 1907 (p. 53), do not, I think, necessarily conflict with the experiments of either Dr. Wehnelt or myself, nor do they appear to vitiate the conclusions we drew from them.

The experiments by which Dr. Wehnelt showed that the negative leak from a lime-covered kathode was independent of the gas pressure were made with currents much smaller than those used by Mr. Soddy. When currents of the order of an ampere per square centimetre of kathode surface are obtained, the phenomenon appears to be accompanied by a glow round the kathode implying that ionisation in the gas itself is playing a part. Prof. J. J. Thomson ("Conduction of Electricity through Gases," second edition, p. 477) has shown that the potential fall required to produce ionisation by collisions with these large currents decreases rapidly as the current increases, so that even the comparatively small fall of 30 volts quoted from Wehnelt's paper would be sufficient to produce a considerable effect of this kind.

When the pressure of the gas falls below the value required to maintain this glow under the assigned conditions as to difference of potential, pressure, &c., there will be a sudden drop in the value of the discharge current. This appears to be what Mr. Soddy has observed.

I do not wish to imply that the negative emission is in all circumstances independent of the presence of gas in the tube. It is well known that the negative discharge from hot metals is particularly sensitive to hydrogen. In a recent paper (Phil. Trans., A, vol. ccvii., pp. 53 *et seq.*) I have described experiments which seem to prove conclusively that the leak from hot platinum is not due to traces of absorbed hydrogen. As the experiments in gases other than hydrogen show that the negative leak from hot platinum is independent of the pressure at low pressures, it is very unlikely that it is caused primarily by traces of any other of the common gases. These gases only appear to increase the fundamental electronic discharge from the hot kathode by a process involving the occurrence of ionisation by collisions.

The foregoing explanation of Mr. Soddy's result is only offered as a suggestion, for two reasons. In the first place, Mr. Soddy's letter is not sufficiently definite as to some of the salient facts, as, for example, the magnitude of the pressure before the current dropped. In the second place, there is a good deal about the behaviour of these Wehnelt kathodes which is imperfectly understood, and which merits further investigation.

O. W. RICHARDSON.

Princeton, N.J., December 7, 1907.

I AM glad to learn Prof. Richardson's view is much the same as that expressed in my letter to NATURE of November 21, 1907, that the currents in question are carried mainly by the residual gas, not by the electrons expelled from the kathode. Into the views that have been expressed in earlier communications it is therefore un-

necessary to enter; but certainly Prof. J. J. Thomson has recognised the important part played by the residual gas, for example, in his lecture reported in NATURE of March 22, 1906. So far as I have yet been able to see, the action of the residual gas in the passage of large currents is much the same whether a Wehnelt kathode or an ordinary electrode is used. There appears to be a definite pressure at which the conductivity is a maximum, and a steady diminution of conductivity when this pressure is either increased or diminished. I do not think, with large currents at least, there is a sudden drop in the discharge current when the pressure is gradually reduced. Of course in the experiment I quoted there was a sudden cessation of the current, but then there is a sudden absorption of the residual gas when the calcium volatilises. The practical difficulties in the way of maintaining a high vacuum in an apparatus containing incandescent bodies by ordinary methods probably led to the earlier view that it was possible to make a vacuum a good conductor by use of an incandescent kathode.

F. SODDY.

British Association Seismology.

An ancient Bogie has again appeared upon the scene. The object it has in view is to show that the seismological work done by the British Association is practically useless. It owes its existence to Prof. Bruno Weigand, of the Strassburg Kais. Hauptstation für Erdbebenforschung, and it was introduced to the notice of seismologists as a "Begrüssung" at the second International Seismological Conference. On this occasion, as a welcome to the British and other delegates, Dr. Weigand dilated at considerable length upon the defects of the instruments used by those who had kindly cooperated with the British Association. At Strassburg a Milne pendulum did not record so many earthquakes as a pendulum of the Reubeur-Ehlerst type, and the records from the first of these instruments indicated very late commencements.

This statement, which month after month and year after year Strassburg has published in the form of registers, has just been emphasised in two new works on seismology, "La Science séismologique," by Comte de Montessus de Ballore, and "Earthquakes," by Prof. W. H. Hobbs. These gentlemen, who I do not think claim to have any practical acquaintance with seismology, candidly tell us that their information came from others. What Dr. Weigand has said about his experiences at Strassburg is no doubt absolutely correct. It is not, however, sufficiently complete; he ought to have added that, although records were not being obtained at Strassburg, they were being obtained from similar instruments in Britain and at stations in other parts of the world. As to whether a seismograph gives satisfactory results or not depends upon its foundation, its adjustment, and, amongst other things, upon the light which is used for photographic purposes. If the light is too high, halation steps in, and all small vibrations are eclipsed in a broadened line.

As Dr. Weigand correctly points out, a factor of great importance connected with the working of a seismograph is the speed with which record-receiving surfaces move. In the early form of the Milne instrument, unless great care was exercised with regard to the light and adjustment of the boom, in consequence of the slowness with which the paper moved, very small earthquakes or preliminary tremors might be lost by the thickening of the line. In the modern form of record-receiving surface, now in use for some years, where the paper moves at 24 cm. per hour, nothing of this sort takes place. The seismograph remains exactly as it was first designed, and with its new recording surface yields results as useful and accurate as those obtained from any other type of instrument, and this it does at a cost of less than 3*l.* per annum. An instrument of higher sensibility than the Milne pendulum cannot be used on soft ground, whilst one which uses a very large quantity of photographic paper per year is beyond the means of small observatories. I am quite content to continue with the instrument I now possess, and, in spite of all criticism, I have no desire to change the same.

JOHN MILNE.

Shide, December 30, 1907.

NO. 1992, VOL. 77]

The Photoelectric Property of Selenium.

In the letter which appeared in NATURE of December 26, Prof. Minchin does not state what kind of air-pump he used to exhaust the tube containing the light-sensitive selenium "bridge." If he used a mercurial pump, the presence of mercury vapour would explain the great fall in resistance observed.

In a paper published many years ago (Proceedings of the Royal Society, 1876-7, vol. xxv., p. 22), I showed that mercury combines at ordinary temperatures with selenium, producing a superficial film of comparatively low resistance. This effect is produced with vitreous selenium as well as with the granular or metallic form.

Selenium converted from the vitreous to the metallic form, in a vacuum free from the vapour of mercury, behaves like selenium rendered light-sensitive in the air in the ordinary way (Draper and Moss, Transactions of the Royal Irish Academy, 1876, vol. xxvi., p. 231). A specimen prepared *in vacuo* was found to have a high resistance, attributable, no doubt, to its spongy form; it was, however, highly sensitive to light.

RICHARD J. MOSS.

The Laboratory, Royal Dublin Society, December 27, 1907.

PROF. MINCHIN'S observation (p. 173) that the resistance of his selenium cells, or "bridges," when placed *in vacuo*, becomes enormously diminished is strongly suggestive of internal contact or short circuit, possibly brought about mechanically by the expansion of a small body of confined air in some part of the arrangement. Such short circuits occur not infrequently under ordinary conditions, and may generally be burnt out, and the cell restored to its original state, by the application for a moment of an E.M.F. of 50 volts or 100 volts.

Selenium cells have often been tested in a vacuum. They are supplied commercially, enclosed in highly exhausted glass tubes, by Dr. Ruhmer, of Berlin.

SHELFORD BIDWELL.

Beechmead, Oatlands Chase, Weybridge,

December 30, 1907.

Echelon Spectroscope.

WHILST employing a thirty-three plate echelon spectro-scope, constructed by Messrs. Adam Hilger for Prof. Schuster, my attention has been directed to a feature of the instrument which needs to be considered in drawing conclusions as to the nature of the light. Using an Arons-mercury lamp as the source of light, the bright green line, for example, is resolved by the echelon into a bright and broad principal line with narrower companion lines on either side, and the principal line sometimes shows a narrow dark line not far from its centre.

Like others who seem to have observed the same effect, I supposed that the principal line showed reversal until I found that, on rotating the echelon slowly about a vertical axis, the dark line moves across the broad bright line, and disappears at the side; then another dark line appears at the opposite side, moves across, and disappears like the first; and so on.

These effects are probably produced by interference bands that have not been considered in the theory of the echelon, but have been described by Gehrcke ("Über eine Interferenzerscheinung am Stufengitter," *Annalen der Physik*, xviii., p. 1074, 1905).

If the echelon is tilted about a horizontal axis, parallel to the plates, these secondary bands become more inclined to the vertical, that is, to the direction of the slit, than the ordinary spectrum lines, and their mutual intersection gives to the spectrum lines a screw-like appearance.

A further investigation of these bands is being made, and it is hoped shortly to publish additional details of their behaviour that may help to explain their origin.

H. STANSFIELD.

The University, Manchester, December 26, 1907.

A Point in the Mathematical Theory of Electricity.

PROF. PEARSON has recently made a statement which if correct is of very great importance to engineers. He declares that the distribution of the stresses due to the water pressure on, and the weight of, a dam is entirely different in the case of a thin slab cut from the dam

than it is in the complete structure, because in the former case the slab can expand freely, whereas in the other case this lateral expansion is prevented.

If some portion of the total load was taken by the dam acting as a horizontal beam, this claim would not be challenged by me, but Prof. Pearson states that his proposition is true independent of any action of this character. On a question of pure mathematics it is no doubt very rash for a mere engineer to differ from Prof. Pearson, but as the point is of great practical importance I make the venture, since the statement appears to me to be opposed to the mathematical theory of elasticity as usually taught. The sole difference between the two cases lies in the fact that when the slab constitutes a portion of a complete dam it is subject to a certain normal stress which Prof. Pearson calls $\gamma\gamma$.

Now the characteristic of this stress is that it produces no appreciable shear in planes parallel to itself or in planes at right angles to itself. In fact, Prof. Pearson states that in both cases we may put $\widehat{yx} = \widehat{yz} = 0$, and that \widehat{xz} is identically the same in both cases.

Consider, then, the slab, taking first the case in which the sides are left free to expand, but in which stresses are produced in it due to the water pressure and its own weight. Taking \widehat{xx} as the stress parallel to the horizon and \widehat{zz} as that parallel to the weight, we have, Prof. Pearson says, the following equations which these must satisfy:—

$$\frac{\partial}{\partial x} \cdot \widehat{xx} + \frac{\partial}{\partial z} \widehat{xz} = 0$$

$$\frac{\partial}{\partial x} \widehat{xz} + \frac{\partial}{\partial z} \widehat{zz} + \rho g = 0.$$

Under these internal stresses the sides of the slab undergo a displacement $v = f(xz)$, say. This displacement, it should be noted, is everywhere finite and continuous.

Now apply, to the slab, forces $\widehat{yy} = F(xz)$, so distributed as to cancel the above displacement, and we get the conditions of the equilibrium when the slab forms part of a complete dam.

Next consider these forces $\widehat{yy} = F(xz)$ to act alone. The characteristic of the internal stress then produced is, as already pointed out, that $\widehat{yx} = \widehat{yz} = \widehat{xz} = 0$, so that the conditions of internal equilibrium reduce to

$$\frac{\partial}{\partial x} \cdot \widehat{xx} = 0$$

$$\frac{\partial}{\partial y} \cdot \widehat{yy} = 0$$

$$\frac{\partial}{\partial z} \widehat{zz} = 0.$$

These and the boundary conditions are obviously satisfied by putting $\widehat{xx} = \widehat{zz} = 0$ and $\widehat{yy} = F(xz)$ throughout. If, at the same time, the conditions of continuity are satisfied, this should be the solution. It would seem that the continuity of the material is necessarily satisfied by the fact that v , the displacement of the surface under the forces, is everywhere finite and continuous. If I am right in this, the stresses \widehat{xx} and \widehat{zz} should be the same in the complete dam as they are in the slab, but Prof. Pearson says this is not the case. H. M. MARTIN.

Croydon, December 22, 1907.

LORD KELVIN: AN APPRECIATION.

LORD KELVIN occupied for a long time a unique and cosmopolitan position as the universally venerated head of the physical science of the age. Where he did not himself create new knowledge, he constantly inspired discovery. Always accessible, always keenly attracted by the work of others and ready to learn, with universal interests, and mental activities untiring even to the end, he for more than half a century was the main practical scientific influence in this country; while for the latter portion of this period his point of view, through the generous

advocacy of Helmholtz and other fellow-workers, became naturalised throughout the world. He was representative, more than any other person, of the combination of abstract scientific advance and mechanical invention which led to the still recent electrical transformation of modern engineering; he sustained and elevated industrial progress by the fire of intellectual genius.

In his earliest scientific work he was the interpreter of Faraday, at a time when support and mathematical elucidation of the intuitions of his genius were much required. In addition to special advances of his own into new domains, such as the theoretical prediction of electric vibrators and their laws forty years before they were utilised by Hertz, and the assertion of the thermochemical principles controlling voltaic batteries, he early became the founder, or rather restorer, of a school—the modern British school of physical science—which aims at moulding the course of general physical theories, even of abstract mathematics itself, by aid of intuitions drawn from exact formulation of the observed course of nature, assisted by illustrations such as may be gleaned even from the study of artificial practical mechanisms. A typical example of this kind of activity was the vortex theory of the molecular structure of matter, which he built on Helmholtz's fundamental discovery of the absolute permanence of vortical motions in a frictionless fluid medium; to a superficial view this is now in the main only an abandoned theory; but those most conversant with the history of the coordination of physical activities, which is the ultimate aim of the science, will allow that the vortex-atom theory was the first illustration that included any adequate idea of the type of interaction of the material atoms and the universal æther in which they subsist, and as such has been the direct ancestor of all subsequent advances towards the mental representation of ultimate physical reality.

In particular Lord Kelvin was the inspirer of Clerk Maxwell, his avowed pupil in all important respects, and was thereby an essential factor in that consolidation and reconstruction of physical science, on a refined electric, or subelectric, basis, which is still in progress, and has been a main glory of recent years.

In another region of his activity he combined delicate mathematical methods of investigation with broad industrial application of the results. It was largely the determined and prolonged struggle to carry through to success the enterprise of Atlantic submarine telegraphy that led to the invention of those appliances for exact measurement which afterwards made general electrical engineering feasible. In this new branch of applied science, his active perception of the essentials for progress assumed the form of generalship; most of the details of development naturally came from others, but he was always ready to emphasise the salient problems, and to acclaim, early and enthusiastically, such nascent inventions as would be pertinent to their mastery.

An example of his firm grasp of the connection of theory and practice is afforded by his work on the prediction of the tides. The recognition that the tidal oscillation is compounded of a limited number of simple harmonic constituents, of known periods, was an outgrowth of physical astronomy, and is mainly due to Laplace; the principle that any oscillatory movement arising from permanent causes is resolvable into simple harmonic constituents, and is to be treated on that basis in all exact science, was the fundamental contribution of Fourier. It remained largely for Lord Kelvin to combine these two principles, supplying the mechanical contrivances necessary for rapid computation, and thereby to control all that is requisite to be known about the tides, while avoiding the complexi-

ties, arising from the irregular forms of the oceans, that would choke any attempt at direct dynamical calculation in detail. Other examples of the same faculty are afforded by his fundamental improvements in ships' compasses and in deep-sea sounding; while his life-long work on problems relating to the speed of ships, the waves they produce and the energy lost in their formation, has been a chief influence in the rational study of the conditions and limitations of marine propulsion.

He will be known to future ages, possibly even more widely, as a main pioneer and creator in the all-embracing science of energy, the greatest physical generalisation of the last century. He was the first to grasp and insist on the universal dynamical, even cosmical, importance of the principle of reversible cyclic processes, which sprang almost in advance of its time from the genius of Carnot. Concurrently with Clausius he soon supplied the necessary logical adjustment of its thermal application; and by his own work, and his collaboration with Joule, he largely constructed the practical essentials of the fundamental, because unifying, modern science of thermodynamics. The depth and generality of the conceptions, which pervade his fragmentary and often hurried writings on this subject, have been recognised sometimes only after the same ideas have been slowly evolved afresh, and acclaimed in their varied applications as advances of the first rank, on the part of other investigators.

In Lord Kelvin there has passed away one of the last commanding figures, perhaps in genius and the variety of his activities as great and memorable as any, in the scientific and intellectual development of the nineteenth century. J. L.

LORD KELVIN AND THE UNIVERSITY OF GLASGOW.

AT a college meeting in 1891, Sir William Thomson said:—"I have been a student of the University of Glasgow fifty-five years to-day, and I hope to continue a student of the University as long as I live." In 1899, when he retired from the professorship which he had held for fifty-three years, Lord Kelvin (as he had then become) applied to the *Senatus Academicus* to be appointed a research student. His name thus remained to the last upon the College roll, and in the list of those who have a right to pursue investigations in the laboratories of natural philosophy.

An academic connection so long, so intimate, and so fruitful is not severed without a deep sense of personal bereavement on the part of the survivors. The university, of which, since 1904, Lord Kelvin was the venerated head, was plunged into deep mourning by the news of his death. Special meetings of the court and senate, and of the executive of the general council, were held, and passed minutes of regret and sympathy. The regular classes were suspended; the courts were silent; the flag that usually waves high over the Kelvin drooped at half-mast. The new institute of natural philosophy which the Chancellor, at its opening in April last, took such pride in displaying to the Prince and Princess of Wales, was closed; and throughout the city, which regards the university's glories as its own, the signs of mourning were everywhere visible. Telegrams and messages from local public bodies, learned societies, and representative men, arrived hourly at Gilmorehill. The note of admiring affection for a great fellow-citizen was prominent in these, for Lord Kelvin was a freeman of the city, and a leader in its technical enterprises, no less than a teacher and investigator in the university. Hence came about a certain wistful acquiescence, on the part of Glasgow men, in the arrangement whereby

he was to be laid to rest beside his intellectual peers in Westminster Abbey. The national tribute was felt to be right and fitting; though not a few were hoping that his burying-place would be in the City Necropolis, where his father and others of his kindred are laid.

In order that expression might be given to the *genius loci*, a memorial service was held by the university in the Bute Hall on Sunday afternoon, December 22, simultaneously with that held at Largs before the funeral company started on their journey southward with Lord Kelvin's body. The hall, which serves as the university chapel, was draped with black, and filled with a congregation of nearly two thousand mourners. All stood, as to the strains of the Dead March the long academic procession, representing the court, senate and other teachers, general council, and students, preceded by the ancient mace swathed in crape, filed in and occupied the stalls and platform. Many of the congregation wore the graduate's robe, and students, men and women alike, wore their undergraduate gowns of scarlet. The Vice-Chancellor, Principal MacAlister, presided, and read the lessons (Job 28, and 1 Corinthians 15) from his stall. The simple service of prayer and praise was conducted by two professors of the faculty of divinity (Drs. Reid and Cooper), and was marked by devout resignation, and by thanksgiving for a great example, rather than by the gloom of unrelieved mourning. The anthem *Nunc Dimittis*, sung by the university voluntary choir, and a special prayer for the university, that in it all science and scholarship might be consecrated to the honour of God and the promotion of human welfare, gave the characteristic notes. There was no sermon or funeral discourse; this will more fittingly be given hereafter. The venerable Lord Blythwood, the Lord Provost, Sir William Bilsland, the president of the faculty of physicians and surgeons, Admiral Bearcroft, Dr. William Wallace, Dr. George Neilson, and many other men of note in the west of Scotland were present. Relatives and others connected with the Chancellor's family, and the officials of the electrical manufacturing firm of Kelvin and White, which he founded, occupied seats near the dais. The funeral march of Chopin closed the ceremony, as the university procession passed out of the hall into the darkness of the winter afternoon, and the silence of the courts that the Chancellor had loved so well.

Telegrams of condolence with the university were received during the week from Mr. Marconi, Glacé Bay; the University of London; University College, Nottingham; the Duke of Argyll, representing His Majesty the King; the Faculty of Science of the University of Rome; Prof. Egoroff, director of the Central Chamber of Weights and Measures, St. Petersburg; Principal Voinarowsky, of the St. Petersburg Electrotechnical Institute; the Chancellor of the Exchequer, Lord Rector of the University; Sir James King, Bt., Dean of Faculties; Rector Borgman, of the Imperial University of St. Petersburg; the Russian Physico-chemical Society; Rector Syniewski and professors of the Polish Technical College, Lvov; Rector Bagatcy and professors of the University of Charkow; Rector de Mbinski and Senate of the University of Lemberg; the Royal College of Surgeons of Edinburgh; the *Senatus* of the U.F. Theological College, Aberdeen; the students of physics of the University of St. Petersburg; President Dini, and the Faculty of Science of the University of Pisa; the University of Liverpool; the Ambassador of France; the *Senatus* of the University of Aberdeen; the St. Petersburg Society of Electrical Engineers; the pro-rector and professors of the University of Jurjew (Dorpat); &c.

FLUCTUATIONS IN HIMALAYAN GLACIERS.¹

NEARLY half a century ago the glaciers of the Alps began to shrink. Their retreat was most rapid in the decade following 1860; since then it has been generally slow, and of late years the ends have been mostly stationary or oscillating. Traditional and other evidence exists of earlier fluctuations, and it suggests that the cycle of change is completed in about half a century. For some time past these fluctuations have been watched in various places, and an International Commission of Glaciers is now occupied in collecting and systematising evidence bearing on the secular and annual oscillations of the ice.

The glaciers in other parts of the world—the Caucasus, parts at least of the Himalayas, and of North America, even of the southern hemisphere—show signs of a recent retreat. As this is indicative of more than local causes, extended and accurate observations have become more than ever desirable. In 1905, Mr. Douglas Freshfield, so well known as a scientific geographer and explorer, urged the authorities in India to record the secular movements of the principal Himalayan glaciers. They undertook the task, and charged the Geological Survey with the collection and distribution of the observations. Last year twelve glaciers were examined, six in the Kashmir region, surveyed by Mr. H. H. Hayden; two in the Lahaul, and four in the Kumaon.

The report before us gives a general account of each glacier and its past history, so far as this can be ascertained, and describes the marks placed to measure its future movements, with sketch-maps and reproduced photographs. In the Hunza region, the glaciers reach lower levels—from seven to eight thousand feet—than in the Lahaul and the Kumaon, where they do not descend below about eleven thousand feet. They may, as usual, be divided into two classes—those flowing in valleys transverse to the trend of the range, and those the course of which is approximately parallel to it; the former, which have the more rapid slope, being the shorter, but descending lower; the latter, such as the Hispar and the Biafo, which attain lengths of twenty-four and thirty-nine miles respectively, being arrested at about ten thousand feet.

Of the six observed, no certain evidence of gain or loss could be obtained about the Barche and Minapin. The great Hispar glacier, traversed by Sir Martin Conway in 1892, has since then slightly retreated. The Hinarche glacier, the lower part of which was explored by the same traveller, has evidently advanced. This, however, may not mean much, for the people of the country assert that it fluctuates in a cycle of six years, advancing and retreating over a distance of some three hundred yards, and was at its maximum when Mr. Hayden saw it. The Yengutsa glacier, however, has gained about two miles in length since Conway's visit, and this, according to native testimony, by a sudden advance about two years

¹ Records of the Geological Survey of India, vol. xxxv., parts iii. and iv. 1907. Containing a Preliminary Survey of Certain Glaciers in the North-west Himalaya, by Officers of the Geological Survey of India. Part iii., Notes on Certain Glaciers in North-west Kashmir, by H. H. Hayden. Pp. 15; 23 plates. Part iv., Glaciers in Lahaul, by H. Walker and E. H. Pascoe; Glaciers in Kumaon, by G. de P. Cotter and J. Caggin Brown. Pp. ix+18; 26 plates. (Published by Order of the Government of India, 1907.) Price 1 rupee each.

before Mr. Hayden's visit, since when it has been stationary. The Hassanabad glacier, a year earlier, made a yet more rapid and extensive progress, for in the course of two and a half months its length was increased, on the lowest estimate, by six miles, but it is now stationary. The chief official in Hunza also stated that many years ago it had reached, and then retreated from, its present position. The accompanying illustration, from one of the sixteen excellent reproduced photographs in the first part, shows the end of the glacier at the time of the surveyors' visit.

The two glaciers in Lahaul, surveyed by Messrs. Walker and Pascoe, are both in the Chandra valley—one of them, the Sonapani, ending at about 13,000 feet above sea level, has in advance of it a desiccated lake-bed dammed by an old terminal moraine, below which are three similar moraines. The other glacier, the Bari Shagri—the boulder covered—has been already noticed more than once by travellers, and their accounts show it to have retreated considerably during the last seventy years. Of the four glaciers in Kumaon, examined by Messrs. Cotter and Brown, the Pindari is already well known to tourists. It descends from lofty peaks, but the



Hassanabad Glacier.

ice appears to move rather slowly, and is not much crevassed. It is said to be retreating, but the surveyors could not succeed in obtaining any exact details. The Milam glacier was described early in the last century as the source of the Ganges. It is now about twelve miles long, but, as old moraines show, was once larger. The terminal ice-cave, about fifty years ago, was some 800 yards in advance of its present position. The Shankalpa glacier is much crevassed, and is probably retreating, though no old moraines are found much in advance of its present snout. Of the fourth, the Poting glacier, old terminal moraines exist lower down the valley, but no evidence was found of a recent retreat. Here also the excellent photographs and sketch-maps will make future movements of the ice easily detected.

These fluctuations, whenever they may occur, must be due either to an increased supply on the upper snowfields, or to a diminished waste of the ice on the lower parts, or to a combination of both; though sometimes, as in the case of the Glacier Blanc and Glacier Noir in the Pelvoux district of Dauphiné,¹ one ice stream may be advancing while another is in retreat. That,

¹ C. Jacob and G. Flusin, "Étude sur le Glacier Noir et le Glacier Blanc" (Commission française des Glaciers), 1905, ch. v.

however, may be a consequence either of a difference of alimention or of the rate at which the ice is moving. Thus long and careful observations are necessary of the latter, of the nature of the advance or retreat, and of other matters, before sufficient data can be obtained to allow of the results obtained in different regions being compared, and their bearing on questions of general meteorology ascertained, but the investigation now begun in the vast northern mountain barrier of Hindustan must ultimately prove to be highly valuable.

T. G. BONNEY.

TIDAL INVESTIGATIONS IN CANADA.

THERE are few countries which possess so large an extent of navigable land-locked waters as does Canada. In such situations the tidal currents are apt to assume great importance, and the prediction of the tides is a task of great difficulty. The Canadian Government has naturally paid much attention to this complex subject, and they are fortunate in having so able an officer as Mr. W. Bell Dawson to place in charge of the operations.

In a paper on "The Currents of the Belle Isle Strait" (Government Printing Office, Ottawa, 1907), Mr. Dawson gives an account of the investigations carried out in the seasons of 1894 and of 1906. The run of the tide in the strait in places is sometimes apparently capricious, but Mr. Dawson shows that in many cases the abnormalities become explicable when properly examined. The results should prove of much value to mariners.

Mr. Dawson has also contributed a paper on "Variations in the Leading Features of the Tide in Different Regions" to the Royal Astronomical Society of Canada (July-August).

It is obvious that in the vast tract of navigable Canadian waters, the cost would be prohibitive of erecting tide-gauges at all the places at which tide-tables are wanted. Hence the calculation of the tides by reference to neighbouring harbours becomes a matter of necessity. It is a subject to which Mr. Dawson has already paid much attention. The ordinary rough rule is to multiply the range of tide at the port of reference by a constant factor, and to apply a constant correction to the times of high and low water. But such a simple rule often leads to enormous errors of prediction. Now Mr. Dawson shows that this factor and correction of time should not be regarded as constant, but should be taken as variable with the position of the moon.

The three points in which the position of the moon is influential are phase, declination, and parallax. These undergo variations in months of slightly different lengths, called the synodic, the tropical, and the anomalistic months. The corrections should be dependent on all these three periods, and thus they acquire a considerable amount of complexity. The most interesting point in Mr. Dawson's investigation is that he finds that, in some cases, it is one of the three factors which is dominant, and elsewhere it is another. So much is this the case that it is often possible to omit all corrections except those which are periodic in one of the three months. The determination of the dominant factor appears to be empirical, and no physical explanation is assigned for this curious conclusion. May we not suspect that when one or two of the monthly variabilities in the corrections are evanescent as regards time and height of high and low water, they are really affecting the tidal currents?

In any case these partially empirical corrections are found to be satisfactory in providing fairly trustworthy tide-tables, by reference to ports where there are tide-gauges and directly computed tide-tables.

G. H. D.

EDUCATION AND RESEARCH IN INDIA.

THE battle between those who believe the sole duty of our professors in universities, colleges and other high educational institutions is to teach, and the best professor one who devotes the whole of his time to teaching, and those who believe that the highest and most fertile kind of teaching is that carried on by a professor who is an investigator as well as a teacher, has been fought out on many occasions and in many places.

Fortunately the latter view in late years has largely prevailed over the former, though the battle has still to be actively carried on in many places. The universities of Europe, at all events those which are the most progressive and of greatest importance, have accepted the fact that in the selection of their professors they must now take only such men as have given distinct proof of capacity for original work in one or other of the great departments of knowledge, and who may be expected to continue their original researches at every possible opportunity.

Unfortunately, in England this spirit has not always been acted on, and the condition of a good many of the institutions devoted to the highest culture is in the matter of research most unsatisfactory, and compares most unfavourably with institutions of similar grade on the Continent.

Nor, indeed, is this lack of original work in England confined to what may be called centres of the highest intellectual activity, but it largely pervades educational and technical institutions of all grades, and it is stated that in many cases where the management of such institutions is in the hands of committees, whose members are distinguished mainly by their success in trade, original research on the part of the staff is practically barred, and, if a professor or teacher is known to be an enthusiastic investigator, he is at once considered to be one who is not doing full justice to the students entrusted to his charge.

It is to be hoped that such instances will become more and more rare as the proper functions of a teacher are better understood, and it is for our universities, and for all educational institutions more or less controlled or influenced by Government, to take the lead in this matter and to insist on the inseparability of research from the highest branches of teaching.

An opportunity of taking such a stand and of doing an almost incalculable amount of good to the higher teaching of a country now appears to lie in the hands of the Indian Government. For a good many years India may be said to have been suffering from an educational unrest, for it was understood by all those who had studied the subject that Indian education had been working on unfortunate lines. Lord Curzon, during the time he was Viceroy, was the first who boldly faced a very difficult problem, and under his direction Indian education was placed upon a much more satisfactory basis. The changes brought about by Lord Curzon's action were very numerous; primary education was largely extended and made more practical, female education was fostered in every possible way, secondary education was also improved, and, lastly, university education was dealt with. Under a new Indian University Act a complete set of new regulations has been prepared, and speaking generally of these regulations it may be said that they have aimed at, first, the influencing of the characters of the students in the colleges and high schools, and, secondly, at securing a practical rather than a book knowledge of the subjects dealt with.

It may also be mentioned that, in cases where a science is being studied, the regulations require each student to have had personal practical instruction

and so far as possible to be practically examined. In the case of the higher degrees, such as D.Lit. and D.Sc., original work on the part of the student is an essential preliminary to his getting the degree, and even with lower degrees provision is made for anyone showing any practical originality to be excused a certain part of the usual theoretical book work.

It is, of course, understood that these regulations will require a stronger professorial staff to man the colleges of the universities than if merely theoretical instruction had to be given. A good many of the colleges attached to the Indian universities, indeed all the largest and most important, are directly managed by the Indian Government, and it is on the action of this body that to a large extent the effective working of the new Indian University Act will depend. The colleges must be dealt with liberally in the matter of staff, or the Act will be inoperative, for if Government colleges, with the resources of Government behind them, do not take the lead, it is useless to expect any others to work up to the desired standard.

An important article in the influential Indian newspaper, *The Pioneer*, of October 31, describes the condition of things in the Indian colleges as being rather critical at the present time. The following is an extract from the article:—

"The first commotion created by Lord Curzon's measures of University Reform has died away long ago; but it must not be overlooked that the work merely initiated by new Acts and sets of Regulations has yet to be actually done, and that rather momentous issues depend on the spirit in which it is done. We are reminded of this by certain papers of a controversial nature, written by members of the Bengal Educational Service, into which we have been allowed an insight. The controversy on the face of it would appear to be one of purely local interest, turning on the question whether the present professorial staff of the Presidency College, Calcutta, is adequate to the demands made on College teaching by the new Regulations of the University. But a perusal of the papers shows that matters of deep importance—the future of all teaching, learning and research in this country are involved in the discussion. An educational officer specially deputed by Government to report on the state and requirements of the Presidency College maintains that if the College is to satisfy the new demands on teaching the Science Professors must at once largely curtail the research work in which they have been indulging in the past, and another officer, closely connected with the College, in endorsing these remarks, tells us that research in the Presidency College has of late become 'something of a bogey,' even demonstrators and assistants being 'involved in researches.' This, he assures us, has led to neglect of pure teaching, and the first measure demanded by the new era of higher education is that the entire staff, from the senior professors downwards, should put aside their researches which, as far as the interests of the College are concerned, are not only useless but positively injurious. Against these views the Science Professors maintain that they and their subordinates have not neglected, and do not mean to neglect, 'teaching,' but that research and training in the methods of research constitutes an important, in fact essential, element in all higher stages of instruction. It is evident that what is being discussed here is no less than the entire future character of the upper sections of our large Colleges and the standing of their Professors. Is it to be a principle recognised, and eventually to be enforced, that Professors lecturing to B.A., B.Sc., M.A., and M.Sc. classes must limit themselves to mere teaching, whereby the antagonisms of research evidently understand the assiduous inculcation into the minds of students of established facts and theories with the special aim of training the recipients of knowledge rapidly to reproduce in writing at examination time as much of the matter committed to memory as they can possibly manage; or should higher teachers in our Colleges be encouraged, possibly definitely expected, to combine with such teach-

ing efforts to rouse in their students the appetite and capacity for original work and research? The latter alternative, of course, would imply that the men to whom higher teaching is entrusted should not be mere school-masters, but should themselves take some active part in the advancement of knowledge and learning."

It is greatly to be hoped that the Indian Government will seize the opportunity and properly strengthen all its colleges with professors who are investigators as well as teachers, and thus at once set a proper standard for the highest education in India. On the action taken now the future of Indian education largely depends, and on the giving of a proper education to the future leaders of the Indian community will depend the peace, progress and prosperity of our Indian Empire.

NOTES.

WE understand that Sir Norman Lockyer has been in communication with the French Minister of Public Instruction with the view of securing active support for the science section of the Franco-British Exhibition to be held in London this year. The Minister has referred the matter to the Paris Academy of Sciences, and it is hoped that the result will be a satisfactory and substantial representation of scientific work in France at the forthcoming exhibition. The various divisions of the British section of the exhibition were described in NATURE of November 21, 1907 (p. 67). This section was instituted with the assistance of the British Science Guild, and is in the course of organisation by a committee including leading representatives of all branches of pure science. The British committee has been given an area of eleven thousand square feet, gratis, for the purpose of exhibiting apparatus, appliances, and results of scientific research. This free grant of space is equivalent to a gift of about 3000*l.*, and in addition the committee has been granted a sum of money in aid of the science section. The executive committee of the British side of the exhibition has thus provided a very favourable opportunity of exhibiting some of the achievements of scientific research and enlightening the general public as to the instruments or methods employed. It is the duty of the men of science of Great Britain to show appreciation of this generous treatment by assisting the committee in every way within their power to make the science section of the exhibition instructive, illuminating, and inspiring to the many thousands who will visit it.

SIR GEORGE DARWIN, K.C.B., F.R.S., has been elected a foreign correspondant of the Paris Academy of Sciences in the section of geography and navigation. Lord Brassey has also been elected a correspondant of the academy.

PROF. RAPHAEL MELDOLA, F.R.S., past-president of the Chemical Society, has been elected president of the Society of Dyers and Colourists in succession to the late Sir W. H. Perkin.

It is announced in *Science* that Mr. Andrew Carnegie has added 400,000*l.* to the endowment of the Carnegie Institution of Washington.

SIR OTTO JAFFE, president of the Belfast Natural History and Philosophical Society, has taken preliminary steps to form a committee to honour the memory of Lord Kelvin by erecting a statue or other suitable memorial in his native city of Belfast.

WE regret to see the announcement of the death of Sir Alfred B. Garrod, F.R.S., in his eighty-ninth year. Dr. Garrod graduated as M.D. of the London University

in 1843, and became a Fellow of the Royal College of Physicians in 1856. He was elected a Fellow of the Royal Society in 1858, and received the honour of knighthood in 1887.

The Belgian Government is organising an Arctic meteorological expedition which will start next summer. The *Revue scientifique* announces that the expedition will be under the command of M. Georges Lecointe, director of the Royal Observatory at Uccle.

REUTER'S representative has received details regarding the Antarctic expedition which is being organised by Dr. Jean Charcot, who hopes to start in July, and expects to be absent for two years. Sufficient provisions to last three years will, however, be taken. The expedition is bent on scientific work. The best route to the Pole is, Dr. Charcot thinks, by way of the Ross Barrier, but this he regards as belonging to English explorers, and does not propose to travel that way. On reaching the Antarctic it is proposed to return to Graham Land, and endeavour to reach Alexander Land, where it is hoped a barrier similar to that of Ross's will be found. The expedition will then endeavour to go as far south as possible. An important part of the equipment will be motor-sledges, which are being built by the Marquis de Dion. With these sledges experiments will be made in the Alps during this winter. The ship for the expedition will be specially strong in view of the ice pressure, and will be of barquentine rig, with compound engines of 550 horse-power. She is to be 135 feet in length, with a beam of 30 feet, and will carry 230 tons of coal and 100 tons of provisions. The crew will consist of twenty-two men, ten of whom were members of Dr. Charcot's last expedition. The scientific staff, in addition to the leader, will number three naval officers, two zoologists, one geologist, and one physicist for magnetic and photographic work. The French Chambers have voted 12,000*l.*, while another sum of equal amount will also be voted by Parliament. Private subscriptions have yielded 2600*l.*, and Dr. Charcot is endeavouring to get a further 3400*l.* The Academy of Sciences has prepared the scientific programme, and the Committee of Missions of the Ministry of Public Instruction has drawn up a favourable report on the subject of the proposed journey. The Marine Department is giving the necessary coal and a valuable collection of scientific instruments, while the Oceanographical Institute of Paris, founded by the Prince of Monaco, is also helping.

In his presidential address to the Royal Society on November 30, 1907, Lord Rayleigh referred to a movement to promote the publication of standard scientific works in embossed type suitable for the use of the blind. Mr. H. M. Taylor, F.R.S., has written out the whole of Mr. C. Smith's "Elementary Algebra" in Braille type; and the embossed edition of this work, consisting of five large royal quarto volumes, containing in the whole eight hundred pages, has been published by the British and Foreign Blind Association at the price of 16*s.* 6*d.* The blind who are interested in subjects of a scientific character are heavily handicapped, because an embossed copy of any book occupies a much larger space than a printed copy of the same book, and is therefore expensive to produce. The result is that though books in embossed type are needed on such subjects as mechanics, physics, astronomy, chemistry, and geology, very few blind persons could afford to purchase these books if their prices were comparable with that at which the embossed edition of the algebra has been published. Accordingly, a fund has been formed to assist the publication, for the use of the

blind, of embossed books on scientific subjects at prices which would not be so high as to be almost prohibitive. This object would be attained by making grants from the fund to Braille printers towards the cost of embossing the plates from which the books are printed. It is thought that 600*l.* or 800*l.* would form a fund large enough to test the usefulness of the scheme, and would be ample for an experiment to last three or four years. The sum of about 300*l.* has already been subscribed or promised in support of the scheme. Donations may be paid to the secretary, Mr. H. M. Taylor, F.R.S., Trinity College, Cambridge, or direct to the "Embossed Scientific Books Fund" at the Cambridge branch of Messrs. Barclay and Co.'s Bank.

THE weather for 1907 affords several features of interest, and the results obtained for London from the observations of the Meteorological Office probably differ somewhat from the common expectation. The aggregate rainfall for the year is 19.5 inches, which is 4.9 inches less than the average for the past thirty-five years. The only months with an excess of rain were April and December. Rain fell on 162 days, and one of the special features of the year was the great frequency with which rain occurred. In October rain fell on twenty-two days, although the aggregate rainfall for the month showed a deficiency of 0.47 inch on the average. The mean temperature for the year was 50° 2, which is 0° 1 above the average. The highest mean in any month was 66° 8, in August, and the mean for each of the three summer months was considerably below the normal. The lowest monthly mean was 38° 5, in February, and with this exception all the six winter months had a temperature in excess of the average. The total range during the year was 57°, the highest temperature being 86°, in September, and the lowest 23°, in January. There were during the year only thirty-four frosty nights, and of these thirty-three occurred in January to March. The sun shone for 1234 hours, which is ninety hours in excess of the average. The Registrar General's returns show that the death-rate for the year was 15.2 per 1000 persons living; this is probably the lowest on record, so that however unpleasant the weather for the year may have proved, there has been a decided gain on the score of mortality.

THE contents of the first three numbers of the Records of the Indian Museum include a large number of papers, chiefly devoted to invertebrates, among which attention may be directed to a series, by Dr. Annandale and others, on the fauna of brackish-water pools at Port Canning.

In the course of a paper on a collection of fishes from Victoria (Australia), published in the October (1907) issue of the Proceedings of the Philadelphia Academy, Mr. H. W. Fowler describes two new species of sea-horse, which, together apparently with the New Zealand *Hippocampus abdominalis*, are referred to the new subgenus *Macleayina*, on account of the greater number of long dorsal fin-rays in comparison with the more typical representatives of the group.

THE barnacles in the collection of the U.S. National Museum form the subject of a long paper by Dr. H. A. Pilsbry constituting Bulletin No. 60 of the museum. Only the pedunculate group and the members of the sessile family Verrucidae are, however, dealt with in this communication. Hitherto the pedunculate species recorded from American waters number about a dozen, while the Verrucidae have been unknown; the author is now enabled to raise the numbers of the former group to fifty-six, and to add five species of the latter.

It has long been a matter of common knowledge that squirrels aid the forester by burying nuts, of which some sprout and ultimately develop into trees, but that he is also indebted to earthworms for aid of a similar nature is claimed by Mr. E. A. Andrews in the November (1907) number of the *American Naturalist* to be a new discovery. In America it appears that the dry, flat fruits of the silver-maple are frequently employed by worms to plug the apertures of their burrows, in the fashion long since described by Darwin. In districts too dry for them to germinate under ordinary conditions, a certain proportion of maple-seeds thus drawn into their holes by the worms were found to sprout and grow into seedlings, and although these ultimately perished under the influence of the late summer drought, the author is of opinion that under less unfavourable conditions a certain number would survive. Worms, he concludes, "probably more than amend, by planting trees, the damage with which they are credited through destroying seedlings in gardens."

EARLY in 1906 Prof. W. B. Benham communicated to *NATURE* (vol. lxxiii., p. 559) a note to the effect that the doubts expressed a short time previously with regard to the alleged carnivorous habits of the kea were not justified by the facts. Since that date he has been endeavouring to obtain more definite information on the subject, and the results of his investigation are published in the Transactions of the New Zealand Institute. A second investigator, Mr. G. R. Marriner, of Canterbury College, has likewise been pursuing inquiries, apparently independently, on the same subject, a summary of which is also published in the same volume. Both writers are in accord in regarding the accusation against the kea of worrying sheep for the sake of feeding on their flesh as now fully proved, and both likewise agree that the prime object of attack is not the kidneys and kidney-fat. Mr. Marriner, in addition, records some very interesting facts concerning the breeding-habits of this bird, notably that the eggs are laid and the young reared in mid-winter at an elevation of between three and four thousand feet above sea-level, where the winter cold is intense.

RATS, in connection with plague, form the subject of a pamphlet and two articles recently published in India. In the first number of *Memoirs of the Indian Museum*, Dr. W. C. Hossack gives an account of the species of rats found in Calcutta, illustrated with several coloured and other plates, and a key to their identification. The so-called Indian mole-rat (*Nesocia bengalensis*) appears to be the species most abundant in the Indian metropolis, where it is probably the one most concerned in the dissemination of plague, as it is extremely common in grain-stores, which are notorious as being centres whence the disease has spread. Originally a field-hunting, grain-storing species, it has in Calcutta become a parasitic inhabitant of stables, grain-stores, &c. "Aids to the Identification of Rats connected with Plague" forms the subject of a pamphlet, by the same author, published by the trustees of the Indian Museums, and printed at the Pioneer Press, Allahabad. Finally, to the third part of another new zoological journal—*Records of the Indian Museum*—Captain C. A. Gourlay contributes a note on the rats of Dacca, eastern Bengal, where the black rat (*Mus rattus*) is the most abundant species.

No. 18 of the *Bulletin biologique* (Dorpat) contains an editorial article on the need for exhibitions devoted to modern biological technique. It is pointed out that the

progress of biological science is now so dependent upon improvements in technique, while the methods in use are so varied and elaborate, and demand an acquaintance with so many branches of science, that without exhibitions of this nature it is almost impossible for workers to keep thoroughly abreast of the times, or to find out in what direction improvements are required: Histology, for example, cannot advance without the aid of chemistry, while the physiologist is largely dependent upon the aid of the mechanic. Similarly, there is a close connection between the study of the tissues and minute structure of animals and optics. It is recommended that an exhibition of this nature should be divided into the following main sections:—(1) methods of collection; (2) the care of living animals and plants; (3) preservation of specimens; (4) transport of living organisms; (5) anatomical methods; (6) methods of microscopic work; (7) methods of studying development; (8) methods of chemical investigation of animal structures; (9) physiological research; (10) the methods of bacteriological investigation; (11) methods of illustration; (12) modelling; (13) museum installation and arrangement.

To the *Times* of December 26, 1907, Sir T. Digby Pigott contributes further information concerning the luminous owl recently seen in Norfolk, from which it appears that the phenomenon was observed by several independent witnesses. A letter from a Welsh fisherman is quoted to the effect that on the night of December 12, 1907, the woollen garments of the writer and his companions were observed to be luminous, and that such phenomena have long been known as demonstrated by an extract from a work published in London in 1704. A very important piece of evidence appeared in the issue of the *Times* of the same date, with the signature of "A Country Teacher." In this the writer states that in February, 1890, he first noticed a luminous appearance in a pair of barn-owls, which then inhabited a farm-building near his school, in Somersetshire. "I saw the luminosity several times," he writes, "but it was not so bright as Sir Digby Pigott's correspondent observed, and usually lasted only for a short time, though I could see the birds flying about after the luminous gleam had ceased. I never saw both birds luminous at the same time, and I am unable to say whether the male or female, or both, possessed this power. . . . I thought the luminosity might be connected with the electrical condition of the atmosphere, but though it was usually brightest and lasted longest when the electrical-potentiality of the atmosphere was highest, it was not always so. . . . I could observe nothing to indicate that the luminosity was under the control of the owl." The writer also mentions that the phenomenon was perfectly familiar to the children in his school, who spoke of the bird as a "glim ulert."

THE importance of cacao cultivation in Grenada is evident from the report for 1906-7 of Mr. R. D. Anstead, superintendent of the botanic station. Plots have been established in five districts with the view of instructing peasant proprietors, and some of the planters have laid out large experimental areas on their estates for carrying out manurial tests. Seedling sugar-canes, of which the variety D. 95 was distributed, cacao, coffee, and bananas were the economic plants chiefly in demand, also seeds of *Castilleja* and *Hevea*. A feature of the report is the inclusion of several photographs. The collection of palms, amounting to eighty named species, contains many valuable kinds for the seeds of which there is a brisk demand.

PROF. A. C. SEWARD contributes to the Transactions of the Geological Society of South Africa, vol. x., a description of a collection of Permo-Carboniferous plants from Zululand and Natal. The material contained a large number of specimens referable to *Glossopteris*, but few of the forms were distinct. Sporangia were discovered on some of the leaves of *Glossopteris indica*, but this does not preclude the possibility of the genus being a pteridosperm; in this respect the association of small winged seeds with the leaves was noted. Other specimens referred to are the genera *Phyllotheca*, *Bothrodendron*, *Vertebraria*, and *Cordaites*. The specimens do not furnish sufficient evidence for determining the precise horizon in the Permo-Carboniferous system; of the coal-bearing strata of Zululand and Natal.

THE Memoirs of the College of Science and Engineering, Kyoto Imperial University, Japan, of which the current issue (vol. i., No. 3) has been received, contains original memoirs by members of the University. Of the thirteen papers, eleven are written in English and two in German. The subjects dealt with comprise the equilibrium between reciprocal salt pairs, reaction between carbonic acid and lead acetate in an aqueous solution, experiments on the utilisation of scrap metal, formation of amines from the halogen imido esters, the refining of copper, electrolytic dissociation of partially neutralised weak acids, short-period magnetographs, the theory of the rotary converter, Beckmann's rearrangement, determination of the solubility of a given substance by means of Pulfrich's refractometer, and dynamometer car experiments. The varied nature of this list affords an indication of the large amount of attention that is now being devoted to research work in pure science in Japan. Of the papers dealing with applied science, that by Mr. D. Saito on the refining of copper should be carefully studied by metallurgists. The author has made a systematic study of the process of dry refining, his investigations having been made upon the blister copper from the Beshi mine in Japan. The blister copper, which is comparatively pure, is refined in a reverberatory furnace using coal as fuel, and the author finds that the greater part of the impurities is oxidised in the earlier stages of refining. Thus, after the end of the first rabbling, the copper contains only 0.03 per cent. of iron and 0.003 per cent. of sulphur, whilst after the second rabbling the iron contents remain almost unchanged, and the copper is practically free from sulphur. If the copper could be re-melted more quickly and the third rabbling period dispensed with, there would be a great economy in fuel and labour. The effect of the first poling is so great that the second poling seems unnecessary, or at least could be shortened.

MR. J. W. PATTERSON, of the Technical College, West Hartlepool, has sent us two very successful colour photographs of rock sections taken between crossed Nicols. They were taken by the Lumière autochrome process, the illuminant being an electric arc light, and reproduce very satisfactorily the interference colours given by plagioclase feldspar, augite, and olivine. It is obvious that this places in the hands of teachers of petrology and geology a very useful aid for illustrating lectures. Autochrome photographs are most successful with slides which are fairly transparent, and should be inspected in a strong light. Mr. Patterson has also obtained photographs of the interference figures yielded by uniaxial and biaxial crystals in convergent polarised light. Some weeks ago we saw a series of colour photographs of this kind exhibited in Kelvingrove Museum, Glasgow. Three-colour photo-

graphic plates appeared two years ago as illustrations of an annual report of the Geological Survey of the Transvaal, and about the same time Prof. E. J. Garwood showed some colour lantern slides of rock sections at the Geological Society, which were the finest of their kind we have seen. They were taken by the Sanger Shephard process, we believe. Undoubtedly methods of colour photography will prove to be of great use in reproducing microscopic slides, not only of rocks, but also of other subjects.

IN *Symons's Meteorological Magazine* for December, 1907, Mr. W. Ellis, F.R.S., formerly superintendent of the magnetical and meteorological department of Greenwich Observatory, gives a useful summary of Greenwich air-temperature observations published for the sixty-five years 1841-1905. The lowest mean daily temperature, 37°.47, is reached on January 12; after February 12 the rise towards spring begins, receiving, however, a slight check in the last week of April. The highest mean daily temperature, 64°.01, is reached on July 15; after August 13 there is a continuous fall to the minimum of winter. The mean annual temperature is 49°.56; the warmest year is 52°, in 1868, and the coldest 46°.28, in 1879. The mean monthly temperature is 38°.6, in January, and 62°.7, in July. The absolute highest reading was 97°.1, on July 15, 1881, and the absolute lowest 4°, on January 9, 1841. The observations give no information on secular change, for which purpose a much longer period than sixty-five years is necessary; there are several interesting differences shown by dividing the series into groups, but Mr. Ellis states that these are clearly due to accidental causes. Nor is any influence traceable to sun-spot variation, which the author considers is practically insignificant in all questions of weather change.

At the meeting of the Royal Academy of Sciences of Amsterdam of October 26, 1907, an interesting paper by Dr. E. Van Everdingen was read on the relations between mortality of infants and high temperatures. It had been previously pointed out in a paper published by the Statistical Bureau of Amsterdam that a distinct maximum in the mortality of children under one year of age existed in the summer months, but an endeavour to find any connection between this maximum in various places and the monthly means of temperature only led to a negative result, although it was still thought probable that the mortality was due to fluctuations of temperature. Following up this idea, Dr. Van Everdingen tabulated the meteorological data for various places in several different ways, one of which was to extract the days on which the temperature exceeded 25° C. between the middle of one month and that of another. In this case the agreement between the deviations of mortality and the number of hot days was so satisfactory that little doubt remains that the high temperatures must be considered as the cause of the increased mortality. The author expresses the hope that, with the aid of other temperature limits and possibly with other methods of grouping the observations, those competent in medical matters will feel inclined to trace the more direct relations of the phenomenon.

IN the *Physical Review* for November, 1907, Mr. W. P. White, of the geophysics laboratory of the Carnegie Institution at Washington, makes a thorough examination of the potentiometer methods of measuring temperature by means of the resistance thermometer or the thermoelectric junction, in order to determine the best arrangement to use in melting-point measurements. He comes to the con-

clusion that the thermoelectric method is the better, that the best time of swing of the galvanometer is five seconds, and that greater use should be made of galvanometer deflections than is done at present, so as to reduce as far as possible potentiometer manipulations. Slide wire potentiometers should be avoided, switch instruments being much more satisfactory, and leakage disturbances should be prevented by surrounding the circuit with a continuous or nearly continuous metallic shield.

THE September (1907) number of *Terrestrial Magnetism and Atmospheric Electricity* contains an abstract, by Mr. J. A. Fleming, of the results obtained by the Ziegler Polar Expedition of 1903-5. Astronomical, survey, tidal, meteorological, and magnetic observations were made during one year at several stations in the Franz Josef Archipelago. Two new maps embody the results of the survey, and indicate the two channels by which the tidal wave from the Atlantic reaches the archipelago. The mean barometric pressure was 29.6 inches, and the mean temperature 8° F.; the mean declination 22° east, the dip 83° north, and the total intensity 0.57 C.G.S. unit. The morning maximum of easterly diurnal declination occurred between five and six o'clock, and the afternoon minimum between eight and nine o'clock.

THE employment of the conversion temperatures of crystallised salts as fixed points in thermometry has been shown recently to possess a real practical value, sodium sulphate having been shown to give the point 32°.383, and sodium bromide 50°.674, both on the international hydrogen scale. In a recent number of the *Zeitschrift für physikalische Chemie* (December 3, 1907) Messrs. T. W. Richards and Franz Wrede put forward manganese chloride, $MnCl_2 + 4H_2O$, as a suitable substance for another fixed point. One re-crystallisation of the commercially pure salt is sufficient to give a point within 0.06 of its final value, and after six re-crystallisations the point is fixed to within 0.001 C. A simple and effective form of thermostat is described and figured, by means of which the correction for the emergent column is reduced to one or two thousandths of a degree. The transition temperature of the tetrahydrate into the dihydrate of manganese chloride is finally given as 58°.089, with a limit of error of ± 0.005 .

THE number of the *Zeitschrift* referred to above contains a paper by Mr. A. Hantsch giving the result of experiments on the cryoscopic behaviour of sulphuric acid. It is shown that, as a criterion of purity, the cryoscopic method far surpasses the ordinary analytical method. The pure monohydrate H_2SO_4 melts at 10°.46, and the addition of either water or sulphur trioxide causes a lowering of the melting point. This result is confirmed by conductivity measurements, the maximum melting point corresponding with the minimum electrical conductivity. It was found possible to determine the molecular weight of various organic substances, methyl sulphate, trinitrobenzene, phthalic anhydride, &c., in pure sulphuric acid, and from the mean results of nine substances by the application of van 't Hoff's formula a latent heat of fusion of 22.94 calories was deduced. The latent heat of fusion, directly determined, was found to be 22.82.

WE have received from Messrs. Philip Harris and Co., Ltd., Birmingham, a copy of their latest price list of chemical apparatus and chemicals. A special feature of this list is the arrangement into sections, which is likely greatly to facilitate its use. The earlier sections deal with general apparatus, such as instruments for weighing and

measuring, apparatus of glass, porcelain, and metal; thermometers, microscopes, spectroscopes, &c.; each of the later sections deals with apparatus used in a special branch of chemistry, for example, brewing, iron and steel analysis, mining, cements, oils, fats and waxes, water and agricultural analysis. Sections are also devoted to physicochemical work, and to driving, stirring, and shaking apparatus. The list is admirably printed and illustrated, and is furnished with a very complete index.

A SERIES of striking addresses delivered on the occasion of the inauguration of Dr. W. A. Noyes as professor of chemistry at the University of Illinois has been printed in *Science* (vol. xxvi., No. 673, pp. 689-714). Prof. H. A. Webber, in discussing the relation of chemistry to agriculture, emphasised in particular the great improvement both in quantity and quality of agricultural crops owing to the utilisation of the results of modern science. Dr. McMurtrie, speaking on the relation of chemistry to the industries, dealt with the need of developing the power and judgment of the industrial chemist by research work carried out in university laboratories; the fact that scientific research is a nation's "greatest financial asset" was especially emphasised. Prof. J. Stieglitz, while deploring the lack of active investigators in the past among teachers in American universities, pointed out that recently there has been a great development in all branches of research, especially since Clark University and the University of Chicago were founded mainly with this object in view. The American teacher is, however, still as a rule overburdened with an excessive amount of routine work, consisting of lecturing, laboratory instruction, and administrative duties, and is seldom afforded aid by the provision of suitable research assistants; funds also are too often lacking. Prof. G. B. Frankforter, in discussing the teaching of chemistry in State universities, pointed to the wonderful growth of German chemical industry as a specimen of what can be done by hearty cooperation between the universities and the leaders of industry of a nation. Chemistry has too often been taught in such a way as to convey the idea that it "serves no other purpose than to be simply dabbled with in college laboratories"; it is not therefore to be wondered at that few realise that its "laws and principles are the foundation stones of our great industrial structures." In his speech on the contribution of chemistry to modern life, Prof. Noyes took as his keynote the supreme importance of purely scientific work undertaken without reference to its technical application; he illustrated his subject by referring to the history of the coal-tar colours and the development of several industries from a purely scientific nucleus. The speeches, taken collectively, constitute a powerful plea for greater support and sympathy being accorded to purely scientific work.

THE second edition, revised and enlarged, of "A Bibliography of the Works of Sir Isaac Newton, together with a List of Books illustrating his Works, and Notes," by Mr. G. J. Gray, will be published this month by Messrs. Bowes and Bowes, Cambridge.

MESSRS. GEORGE PHILIP AND SON, LTD., have sent us two specimen sheets of their "Imperial" series of maps. The price of each sheet is 2s. 6d., but the maps can also be obtained on cloth, with rollers and varnished, at 3s. 6d. each. Each sheet is about 28 inches by 19 inches, and contains several physical maps. One sheet provides a map of the world in hemispheres; showing physical features in the familiar shades of green, brown, and blue, together with three maps of the world indicating isobars, rainfall,

and regional vegetation respectively. The other sheet includes maps of the polar regions on a scale of 1:35,000,000, and three isothermal maps of the world.

We have received two volumes of the "Agricultural Statistics of India" for the years 1901-2 to 1905-6. The statistics have been compiled in the office of the Director-General of Commercial Intelligence for the Department of Revenue and Agriculture of the Government of India. The first volume deals with British India, and the second with native States. The total area of India is given as 1,133,977,169 acres (1,771,839 square miles), and the total area of the British provinces is 744,907,040 acres (1,163,605 square miles). From a prefatory note to vol. i. the actual area of British India for which statistics are prepared appears to be 557,236,906 acres (870,683 square miles). Less than two-thirds of this area is available for cultivation; 67,976,325 acres are under forests, and land absolutely barren or unculturable, or covered by buildings, water, and roads, and so on, amounts to 135,329,173 acres. The balance represents the area available for cultivation, of which 207,683,741 acres were actually cropped during the year. Detailed information is supplied in the volumes as to the kind of crops and extent of each, the live-stock, revenue, and transfers of land. Full particulars as to the production of tea and coffee are also supplied. The table dealing with the estimated number of acres on which indigo is cultivated, and the yield in hundredweights, reveals the interesting fact that there was a revival in the indigo industry during 1906-7. The number of acres under cultivation and the yield both show a decided increase over 1905-6, and the yield an increase over that of 1904-5, but both sets of numbers still show a great falling off when compared with 1903-4.

OUR ASTRONOMICAL COLUMN.

ASTRONOMICAL OCCURRENCES IN JANUARY:—

- Jan. 2-3. Epoch of January meteors (Radiant $230^{\circ} + 53^{\circ}$).
 3. 1h. 51m. to 6h. 42m. Transit of Jupiter's Satellite IV. (Callisto).
 .. Total eclipse of the Sun, invisible in England.
 4. 17h. Neptune in opposition to the Sun.
 5. 8h. 20m. Venus in conjunction with Moon. Venus $1^{\circ} 45' N$.
 15. 3h. 32m. to 7h. 14m. Transit of Jupiter's Satellite III. (Ganymede).
 17. 4h. 19m. to 4h. 34m. Moon occults δ Geminorum.
 19. 2h. 57m. Jupiter in conjunction with Moon. Jupiter $1^{\circ} 33' S$.
 .. 11h. 56m. Minimum of Algol (β Persei).
 22. 6h. 48m. to 10h. 31m. Transit of Jupiter's Satellite III. (Ganymede).
 .. 8h. 45m. Minimum of Algol (β Persei).
 25. 5h. 34m. Minimum of Algol (β Persei).
 29. 9h. Opposition of Jupiter to the Sun.
 .. 10h. 4m. to 13h. 46m. Transit of Jupiter's Satellite III. (Ganymede).

DANIEL'S COMET, 1907*d*.—In No. 4223 of the *Astronomische Nachrichten* (p. 375, December 20, 1907) Herr Kritzinger publishes a continuation of his ephemeris for comet 1907*d*, extending from January 1 to March 5. From this we see that the comet is now apparently travelling, very slowly and in a direction nearly due east, through the constellation Libra. On January 1 its position was $\alpha=14h. 47m.$, $\delta=-9^{\circ} 14'$, and its computed magnitude was 9.9. On February 1 the position will be $\alpha=15h. 8m.$, $\delta=-9^{\circ} 0'$, and its magnitude 10.2. Thus, on the latter date, the comet will be very near to the star β Libræ, and during the present month it will rise some five hours before sunrise.

EPHEMERIS FOR ENCKE'S COMET.—According to elements published in No. 4222 of the *Astronomische Nachrichten*,

as an abstract from the *Bulletin de l'Académie des Sciences de St. Petersburg*, 1907, Encke's comet should arrive at perihelion on February 22. An ephemeris, calculated by M. Kamensky and Fr. Korolikov, is given for the period January 3 to April 30. On the former date the comet's position will be α (app.)= $23h. 1m. 30s.$, δ (app.) $1^{\circ} 45' 17''$; after that it will apparently move in a north-easterly direction through the constellation Pisces in a line nearly parallel to the stars γ , ϵ , and ω Piscium, being very near to ϵ on February 4.

ABSOLUTE SCALE OF PHOTOGRAPHIC MAGNITUDES.—The November (1907) number of the *Astrophysical Journal* (No. 4, vol. xxvi., p. 244) contains a description of a method devised by Messrs. J. A. Parkhurst and F. C. Jordan for the absolute photographic magnitudes of stars. An ingeniously constructed sensitometer box is employed for illuminating certain areas of a photographic plate simultaneously by lights differing in intensity by a known ratio. Plates thus prepared were measured for the opacity of the different areas by means of a Hartmann "mikrophotometer," which was also used to measure the opacity of the extra-focal star images. A comparison of the results obtained for the Pleiades stars with those published by Schwarzschild proved satisfactory, and indicated that within narrow limits the scale obtained was correct. It also showed that the method is capable of yielding results of extreme accuracy over a range of about two magnitudes on a single plate; that it should prove useful for determining the light curves of Algol-type and short-period variables is shown by some results given in the paper.

ANNUAL ASTRONOMICAL PUBLICATIONS.—The *Annuaire* for the year 1908, published by the Bureau des Longitudes, is of the usual form, and, in addition to its numerous invaluable astronomical tables, occupying 400 pages, it contains some 360 pages of chemical and physical data. Of the six appendices, dealing with astronomical subjects, we would direct our readers' particular attention to two, the first by M. Bigourdan on "Les Distances des Astres," the second by M. E. Guyot describing "L'École d'Astronomie pratique de l'Observatoire de Montsouris."

The *Companion to the Observatory* is practically of the same form as in previous years. The increase in the number of known variable stars renders it impossible to add all the new ones to the list, year by year, so it has been decided to reduce the number of ephemerides given, subsequently adding to them if it proves desirable. Complete lists of the Algol variables are given, but only a selected few of the ephemerides. The "inferred" magnetic elements for 1908 (Greenwich) are:—dec., $15^{\circ} 55' W$; horizontal force, 0.1854 (C.G.S.); dip, $66^{\circ} 55'$.

Mr. Arthur Mee's card calendar, "The Heavens at a Glance, 1908," is of the usual form, and is an extremely useful publication for astronomical observers. It may be obtained from Mr. Mee, Llanishen, Cardiff, price 7*d*. post free.

THE CANYON DIABLO METEORITES.—Part ii., vol. iv., of the Smithsonian Miscellaneous Collections (p. 203, No. 1725) contains an interesting illustrated discussion of the Canyon Diablo meteorites, by Messrs. G. P. Merrill and Wirt Tassin. The former discusses the distribution and physical characters of the "shale balls" found in such large quantities in the vicinity of the canyon in Coconino County, Arizona. These balls are roughly globular in outline, of all weights up to 50 lb., and consist of an exterior coating of hydrated oxide of iron frequently enclosing unoxidised iron centres, or nuclei, the intermediate shell showing a green hydroxide of nickel mingled with oxides of iron. The inspection of a number of these balls and of the ground in which they are found apparently strengthens the theory of the meteoric origin of the crater.

Mr. Tassin deals with the chemical analysis of the "finds," and shows that these "shale balls" differ to some extent in their chemical composition from the ordinary Canyon Diablo iron. They contain appreciable quantities of chlorine, whereas none has been found in the ordinary "iron," and also contain more phosphorus; to the presence of these two elements the increased oxidation of the "shale balls" may be ascribed.

THE STRESSES IN MASONRY DAMS.

THE memoir¹ referred to at the foot of this column embodies the results of further work, mainly experimental, on the design of masonry dams, and is a continuation of the work of Atcherley and Pearson described in an earlier memoir of the same series.² In the latter paper the authors discussed the imperfections of the present theory of masonry dams, in which the normal stress on horizontal sections is assumed to be linear, and nowhere tensile. This leads to the well-known condition of stability, that the centre of pressure on horizontal sections must fall within the middle-third, and the linearity of normal stress involves a parabolic distribution of shearing stress. Atcherley and Pearson criticised the action of engineers in ignoring the shear stress distribution, and in merely considering frictional stability as the criterion of safety as regards horizontal sliding. They demonstrated the existence of tension on some vertical sections of existing dams using the common theory, and showed that the mid-third rule was not followed consistently throughout the design.

In the memoir now under review, the authors point out the conditions for a true beam problem, viz.:—(1) the dimensions of cross-section are small compared with the length and with the radius of curvature; (2) true cross-sections, i.e. sections perpendicular to the line of centroids, exist. As these conditions are not rigidly fulfilled in a masonry dam, the authors refuse to accept any results based on a simple beam analysis, and proceed to an endeavour to throw experimental light on the current mid-third theory, which they summarise as follows:—

- (1) The dam shall not be subjected to tensile stresses.
- (2) This involves the line of resistance lying in the middle-third of horizontal sections.
- (3) Condition (2) has meaning solely on the assumption that the normal stresses are linear.
- (4) Linearity of normal stress involves the distribution of shearing stress being parabolic.

The case of an infinitely long dam, or a dam of finite length abutting against rigid supports, is considered mathematically. It is assumed to be straight, to have a plane face at any batter, and a flank curved in any manner. Regarding it as a homogeneous isotropic material, the laws of elasticity lead to a differential expression of a stress function V , which function has to fit the boundary conditions of the dam, viz.:—(a) on face where shear=0; normal stress=water pressure; (b) on top and flank, where shear=0; normal stress=0; (c) on base, where the shear and normal stresses have their actual values. It is stated that (c) is generally ignored, and its existence prevents a mathematical solution being obtained.

The memoir proceeds:—“The engineer using the middle-third rule, and thus assuming the hypothesis of linear normal stress, has *actually* (the italics are ours) assumed the stresses over the base. Consciously or unconsciously he has asserted that the pressure is linear and the shear parabolic.” The engineer has perhaps some excuse for his assumption, as a mathematical difficulty cannot stand in the way of building a dam. In many other cases, say that of a large masonry arch, in the light of purely theoretical considerations, the action of the engineer, usually *conscious* we imagine, may savour a little of fools stepping in where angels fear to tread. In saying this,

¹ “An Experimental Study of the Stresses in Masonry Dams.” By Karl Pearson, F.R.S., and A. F. Campbell Pollard, assisted by C. W. Whelan and L. F. Richardson. Drapers' Company Research Memoirs. Technical Series v. Price 7s.

² “On Some Disregarded Points in the Stability of Masonry Dams.” By L. W. Atcherley and Karl Pearson, F.R.S. Pp. 44+plates. (London: Dulau and Co., 1907.) Price 3s. 6d.

we would in no sense wish to convey the impression that the authors hold engineers responsible for what they regard as the uncertainty in the design of dams. Indeed, they expressly disclaim any such intention, frankly recognising the difficulties of the problem. Their results are put forward as preliminary only to further investigation, which they suggest might possibly be undertaken by some such body as the Institution of Civil Engineers. Their investigation shows that the boundary conditions are best fitted by a triangular dam, but that the conditions cannot hold for rectangular or trapezoidal sections. To quote from the memoir:—“Purely mathematical researches suggest no great hope of real advance in what is notwithstanding an urgent practical problem. It does not seem probable that they would provide any but the roughest approximations to the actual conditions.” The method by which engineers escape from the horns of the mathematical dilemma is viewed with some misgivings, and the authors seek, in experimental work, a fold in which both engineers and mathematicians may dwell together in harmony.

Experimental Work.

The object of the work was to determine the actual straining actions in model dams by direct measurement,

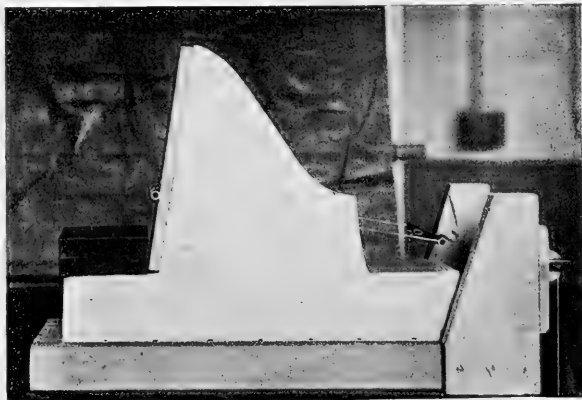

FIG. 1.—Vyrvny-type dam, moderate water pressure.

and, at the suggestion of the late Sir Benjamin Baker, jelly was adopted as the material of the dams. After much experiment suitable cream-white material made of gelatin, glycerin, and colouring matter was obtained. The size of models was as follows:—base, 45 cm.; height, 35 cm.; breadth, 9 cm. to 10 cm.; substratum, 45 cm.; by 9 cm. or 10 cm. deep. Fig. 1 shows a typical model with lines ruled on the face for the distortion measurements. After much trouble in satisfactorily fixing the models to a rigid wooden base, copper gauze was nailed to the wood and heated. The model was then placed on it, and on cooling was bonded securely to the gauze.

Noting the experimental difficulty of attempting to use a dam with rigid, parallel ends, the authors proceed to a mathematical investigation of the stresses in a sheet of elastic material with free sides, i.e. a vertical plate with fixed base, no stress on sides, and subjected to a normal stress on part of its edge only. They conclude that with certain limitations there is an identity of stress equations, and that an experimental plate dam without side supports can be used to test the distribution of horizontal shear, by measurement of the distortion of lines ruled on its sides. If the distribution is not parabolic the normal stresses are not linear. The difficulty of measuring the local values of the stretch and squeeze of the jelly prevented any direct estimate of normal stress being obtained, and only the

existence of tension in the substratum and the manner of final rupture were noted.

Experiments were made on five models:—

(a) Water gelatin model, Vyrnwy type, tested to rupture, and illustrating preliminary difficulties.

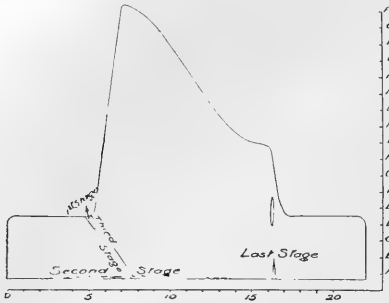

FIG. 2.—Rupture history of a large jelly-dam of the Vyrnwy type.

(b) Control dam, Vyrnwy type, very stiff jelly.

(c) Dam of Vyrnwy type, moderately stiff jelly.

(d) Dam of Assuan type, moderately stiff jelly.

(e) Dam of Assuan type, moderately stiff jelly, tested by optical methods.

The pressure was applied to the face of the models in three ways:—(1) By a board pressing against the face and loaded normally at the centre of pressure by means of a stirrup and shot bucket. A rubber tube was placed between the board and model to distribute the load so as to imitate water pressure. (2) By a board as in (1) without tubing, the jelly itself distributing the load. (3) By an elastic water bag resting on the front of substratum and against the face of the dam, the sides of the bag being rigid and independently supported. The last method gives a true distribution on the face and substratum, and obviates the necessity of piling weights on the latter to maintain equilibrium; but the pressure cannot be varied relatively to the density of the dam as in methods (1) and (2), nor can the dam be tested to rupture. The strains were, in fact, only measurable by delicate optical means.

The Vyrnwy model, tested to rupture, behaved as shown in Fig. 2. The initial cracking gradually extended across the entire front, being followed by the tearing of the jelly from the cement or of the cement itself at the base connection. Then followed the third and last stages, the dam finally toppling over the tail, which separated at the vertical cracks. This experiment indicates weakness in the

substratum, and tension across vertical sections at the tail. It may be remarked that the failure occurred at the section of discontinuity of contour, where the stresses in any actual dam become distributed through the surrounding earth in an indeterminate manner, and further that the extent to which the connection of such a model to a rigid base (though good experimentally) imitates the bedding of the substratum of an actual dam is also unknown. The existence of tension on vertical sections is emphasised by the authors.

Distribution of Shear.

This was determined by measuring the angular displacement of lines ruled on the ends of the models. It is admitted that no great exactitude is possible, and the following sources of possible error are indicated:—

(a) Inaccuracy of ruling on a jelly face; (b) ruling model while resting on its side, giving error especially near the contour; (c) distortion due to elastic effect of weight of vertical jelly; (d) set due to weight of jelly, or to shrinkage in course of time. The authors think that (a) and (b), while sensible, are not very large, but that (d) is more important, and not easy to determine. If the model is photographed in a vertical position the change of the angles from 90° may not represent the slide due to weight only, since errors (a), (b), and (d) affect the result. Similarly, the combined effect of weight and water pressure cannot be found exactly; but if the model is photographed on the same occasion, with and without water pressure, the errors are largely eliminated, and the change of angle on the two photographs gives the slide due to water pressure alone. The mid-third rule is applied to the cases of reservoir empty and reservoir full. Hence it must apply to the water pressure alone, and the change of angle as measured should give a parabolic curve if the linearity of normal stress holds.

Typical results for the Assuan dam model are shown in Fig. 3 for the sections D, E, and F between verticals 6 and 14. The dotted lines correspond to doubtful measurements near the contour, which, it may be noted, appears to be rather large at section F. There are indications of negative shear near the contours, but the liability to error and uncertainty of measurement must be remembered in any attempt to interpret the curves in this region. There is no resemblance to a parabolic distribution. The curves of shear due to weight, and to weight and pressure combined, shown in the memoir, are

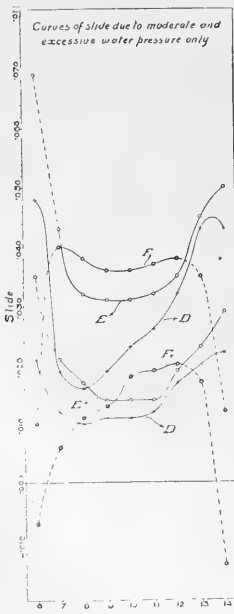

Curves of slide on the horizontal sections D, E, F, G.

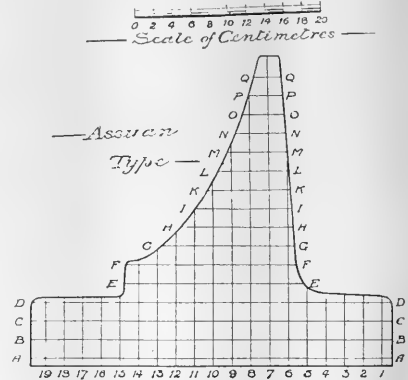

Key figure to the network on the Assuan model.

FIG. 5.

extremely wavy in outline, and nothing short of a quartic would in any way represent them between verticals 6 and 14; but bearing in mind the special liability to error in these cases, the curves are not of the same interest as

those shown in Fig. 3. Similar results are shown for the Vyrnwy type dam.

As a result of the first set of tests, the authors maintain that, allowing for all irregularity in measurement and material, there is no approach to linearity of normal stress up at least two-thirds, and probably up the whole height of dams of current form. The mid-third rule is, therefore, considered valueless as a stability test, and the success of engineers in building stable dams is attributed more to experience in choice of contours, and in the use of a large factor of safety than to any validity in the method of design. The complexity of the problem and the variations of shear distribution led the authors to make a second series of experiments, using many experimental refinements. The general results were of the same character, and an interesting set of curves is presented showing the actual stresses in the Assuan dam as calculated from the more refined measurements on the model. These curves, like the preceding set, are rather irregular, and it is difficult to believe that they can represent the variations of stress in a body having any approach to homogeneity.

Before concluding the memoir with some attempts at semi-empirical determination of stresses, the following processes are suggested for dealing practically with any proposed design:—

"(1) Form a glycerin-gelatin white pigmented jelly dam of the given contour. Determine the form and fixing of the substratum to represent as closely as may be feasible the local conditions. Rule the surface.

"(2) Apply water pressure and determine by the methods indicated above, using either a direct or optical micrometer, the shear distributions. Ascertain the forms of the horizontal and vertical section shear curves.

"(3) Thence by integration—of course mechanical—find the distribution of normal stress along one or two base sections. From these deduce the stretches and squeezes, and take as definite conditions of stability that the maximum stretch and squeeze shall be less than certain values which may be effectively fixed by experiment."

The authors then say that, with such a test, dams like the Vyrnwy and Assuan are found to be theoretically stable, whereas the mid-third rule gives only an apparent theoretical stability.

We are grateful to the authors for their presentation of the interesting results of such difficult experiments, and hope that their work may bear fruit. Their results must stimulate discussion of a highly important subject; but we imagine that the day is not yet when the civil engineer will proceed to the design of a masonry dam, as the authors suggest, by "forming a glycerin-gelatin white pigmented jelly of the given contour, and determining the form and fixing of the substratum so as to represent as closely as may be feasible the local conditions." Here, it seems to us, there are added to the uncertainties of actual conditions, a set of experimental processes liable to error at many points. He will probably prefer to base a new project on the designs of existing dams, modified as these may be from time to time in the light of new ideas, and perhaps by suggestions coming from work of the character of that under review. E. BROWN.

THE ETHNOLOGY OF AFRICA.

THE communication by Dr. F. C. Shrubbsall—"Notes on some Bushman Crania and Bones from the South African Museum, Cape Town"—issued as part v., vol. v., of "Annals of the South African Museum," in continuation of a paper by the same author in the Journal of the Royal Anthropological Institute for 1897, is an important contribution to the ethnology of that region. Incidentally, it marks a reaction against established methods in anthropometry, which, particularly in the case of mixed races, are now treated with well-merited suspicion. In place of an induction founded upon a single "index" derived from the study of the relative magnitude of one skull dimension in terms per cent. of some other dimension, the present paper is based on no less than eighteen factors, and the figures have been subjected to statistical investigation on the most modern lines.

The inquiry starts from a series, unfortunately limited in numbers, of skulls of the race known as the Strandloppers found in caves along the south-eastern seaboard. These constitute a group more pure than that of the Bushmen, and apparently quite distinct from that of the Hottentots. The up-country Bushmen are intermediate between the Strandloppers and the Hottentots. The latter, again, present dimensions between the up-country Bushmen and the Bantu, and in many characters they approach the Negroes of British Central Africa more closely than the Kafir tribes of the east coast. The Central African Pigmies are by their prognathism clearly removed from the Bushmen, and those of the forest zone seem to be largely mixed with the Negro strain. Thus the purest dwarf race is, or was recently, located on the coast at the extreme south of the continent, the furthest point to which, under pressure, they could retreat.

Eastern and part of south-western Africa are occupied by distinct races of Bantu speech, between whom, in character as well as in position, the Hottentots seem to be intermediate. Quite distinct from these races already mentioned are the Somalis and Gallas, of whose physical character little is known. The Masai further south may be allied to these, but they are quite distinct from the Bantu-speaking Negroes. The West African Bantus, between the Rio del Rey and the Congo, in some respects resemble the eastern tribes of the same stock, in others approximate to the Pigmies.

The race history of South Africa may thus be reconstructed—the first inhabitants were of the Bushman type. Round the great lakes and in the Upper Nile valley the tall Negro tribes were developed, or at least are found in occupation of this region. Pressure from the east drove a large section of these southwards, and these in their turn pressed the Bushmen partly to the extreme southern coast, partly into the forest zone, where they intermingled with their neighbours. Some of the Negroes, again, passed north of the forest tract towards the Atlantic shores, and under pressure of tribes from across the Sahara were in part driven back to the forest, and in part down to the western sea, where in an unsuitable environment their physique deteriorated. Some of these Negroes may have been forced down the Nile valley, taking with them or driving before them any survivors of the northern Bush races, who thus came into contact with Egypt; or, as an alternative, it is not impossible that the range of the Bush peoples may have previously extended much further to the north than is usually supposed.

These conclusions rest, as we have said, on a comparatively small number of skulls. It is to be hoped that a fuller supply of African crania may soon be available by which these interesting speculations may be more adequately tested.

THE PLACE OF THE LABORATORY IN THE TRAINING OF ENGINEERS.¹

IT is now generally conceded that the advancement and prosperity of an engineering establishment depend upon the number of well-trained employees it possesses, but much difference of opinion exists as to whether the education given in our engineering colleges is of the kind best fitted to produce the type of man who will be of real value to his firm.

As a rule, at the present day, a boy who intends to become an engineer, on leaving school takes up a three or four years' course at an engineering college. On leaving college he will be found to have a fair theoretical knowledge of engineering, to be capable of making a drawing, of testing specimens of materials, of taking indicator cards, and, generally, of carrying on an ordinary engine or boiler trial. As a rule, however, he is incapable of making much practical use of his scientific knowledge, and if compelled to act on his own responsibility in the case of some mechanical problem often fails badly. Many employers thus look coldly on a system of education which produces such poor results, and we have here an explanation.

¹ Based upon a paper read before the Institution of Engineers and Ship-builders in Scotland, by Prof. A. L. McLellan.

ation why the chief draughtsman and foreman so often state that they would rather have a boy straight from school than one who has undergone a college training.

To one experienced in both the practical and academic departments of engineering, it is evident that the average college training is unsatisfactory. It has grown up because it created least disturbance to the existing state of things, and the development of this system is chiefly the fault of the employers themselves. Anyone who has read the literature dealing with technical instruction must come to the conclusion that the advance in education has been almost entirely due to the students alone. They have seen the necessity for information concerning the principles of engineering, and have in the past attended college courses with no encouragement from outside sources. At the present day this is fortunately changed, and employers are, on the whole, not unwilling to support a system of education which they see is advantageous to themselves.

The author is of the opinion that our college engineering courses would be vastly improved if it were made

three years he would keep up his studies, especially devoting himself to mathematics and physics. At the end of this time he ought to return to college, and take during the winter the second year's course. The following summer would be again spent in the workshops, and the next winter would be devoted to the third course of college work. Before allowing an apprentice to take up his second year's course at college, it must be seen that he can give evidence of having made material progress in his theoretical knowledge during his three years at the works. The method by which the student would continue his scientific education in this period must of necessity depend upon the employer. Attendance at evening classes would produce least disturbance in the works, and there is no doubt that a hard-working student could get a fair amount of knowledge in this manner. The other alternative is that the apprentices be allowed to attend day classes for, say, two afternoons per week—a system already being tried by several firms.

The advantages of such a system are obvious. The

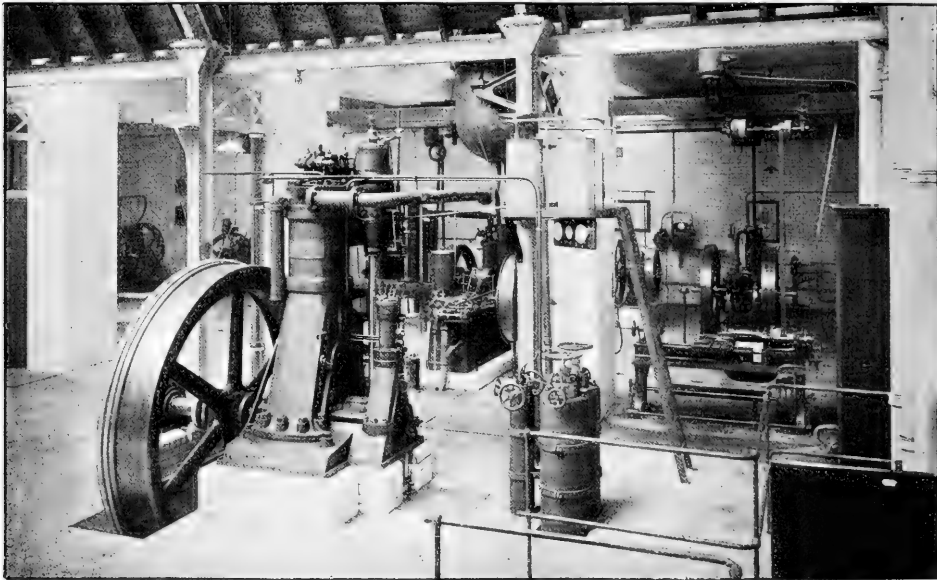

Gas and oil engines. Glasgow and West of Scotland Technical College.

the rule that a considerable amount of workshop practice should precede the final attendance at college. In support of this proposal it may be pointed out that if college training is to produce men who are capable of inventing new processes and improving existing methods of manufacture, then the training must not confine itself altogether to principles, but must direct attention to current engineering work. It therefore follows that the student who wishes to take up his technical studies with profit should not only be prepared with a sufficient knowledge of mathematics and physics, but must also have a working acquaintance with engineering practice. The following plan is suggested as one likely to be the most fruitful.

The student after leaving school should immediately proceed to college, and there take up the first-year general course, whereby he will gain a preliminary grounding in mathematics and science. At the close of the college session he ought to enter an engineering works, where he should remain for at least three years. During these

student would take up his second and third years' college work with such a preliminary practical and theoretical training that the whole character of present-day college classes could be changed. The elementary descriptive lectures, so necessary to schoolboys, could be omitted, and in their place lectures of vital importance to every-day engineering practice could be given, and the most recent developments could be described and discussed. The laboratories, instead of being places for elementary testing, might develop into schools for real research. Practical problems that had arisen during workshop experience might be settled by direct experiment, and an amount of information gathered that would in a short time lead to an immense improvement in our national engineering. It appears to be almost universally believed that inventions are the outcome of sudden inspiration to men of genius, and, like poetic effusions, are independent of environment and experience. Such an idea is far from the truth, for most great discoveries have only been evolved after the

closest research, and then by men who have had a training of such a kind that their critical faculties are strongly developed. It cannot be too strongly impressed upon employers how much more valuable an apprentice would be were he to have an opportunity of continuing his mental training in the laboratories of our well-equipped colleges after having first been impressed with the real problems of his calling by some years in engineering works.

The plan suggested above can only be carried out with the help of the employer. His works may at first suffer some disorganisation, but he must see that this is a national problem, and that plan of training can only be the best which results from cooperation with the engineering colleges, even although such a system involves some personal sacrifice.

There must be something radically wrong with a system of apprentice education which appears to be quickly bringing British engineers to the position of manufacturers, under license, of foreign inventions. It is quite evident that by allowing a student to undergo considerable workshop experience before attending his final college course the trained engineer of moderate ability would be a sounder man, while the clever man would have an opportunity of exploiting his capacity for research work. It must, however, be insisted upon that the proper education of our young engineers depends altogether upon the attitude of the employers towards it. If they do not realise the national significance of such higher scientific training as is here contemplated, it is useless for the heads of our colleges to devote attention to schemes of study capable of promoting it.

In designing the laboratories of the Glasgow and West of Scotland Technical College, provision has been made for the comparatively large number of older students attending the final courses in engineering by putting in a number of machines adapted for research work. The illustration shows one corner of the laboratory devoted to motive-power engineering.

AMERICAN INVESTIGATIONS ON ELECTROLYTIC CONDUCTIVITY.¹

THE two monographs here noticed owe their existence principally to the means placed at the disposal of American workers by the Carnegie Institution of Washington. Without such aid these extensive systematic researches could scarcely have been undertaken, and their publication, unless in abbreviated form, would have presented considerable difficulties.

The report by Prof. Noyes on the work of himself and his collaborators is of the utmost value to all those who are interested in problems connected with the conductivity of aqueous solutions, salt-hydrolysis, and the like. The main object of the research was to obtain accurate values for the electrical conductivity of solutions in a range of temperature from 0° to 300°, and the chief difficulty experienced in the construction of a conductivity vessel which should be at once capable of resisting the high vapour pressure of solutions up to the critical point of water, and of yielding only traces of conducting impurity to the aqueous solutions it contained. By three years of patient labour Prof. Noyes and Dr. Coolidge succeeded in constructing a platinum-lined bomb with insulated electrodes, which even at high temperatures and with salt-solutions as dilute as 0.005 normal gives conductivity measurements accurate within 0.2 per cent. With this apparatus the conductivities of typical substances were measured, the results obtained being given and discussed in detail in the report. The substances embraced in the investigation are the chlorides of sodium, potassium, and ammonium, the nitrates of silver and barium, the sulphates of potassium and magnesium, the acetates of sodium and ammonium, the hydroxides of barium, sodium, and ammonium, and, finally, hydrochloric, sulphuric, nitric,

¹ "The Electrical Conductivity of Aqueous Solutions." By Arthur A. Noyes. Pp. vi+352. (Washington: Carnegie Institution, 1907.)

² "Conductivity and Viscosity in Mixed Solvents." By Harry C. Jones. Pp. v+235. (Washington: Carnegie Institution, 1927.)

phosphoric, and acetic acids. In order to obtain data for calculating the ionisation constant of water, the conductivities of diketotetrahydrothiazole and its ammonium salt were also measured. The value of this constant as so determined agrees well with that obtained by Kohlrausch from the conductivity of pure water. Two special sections deal with the solubility of silver chloride, bromide, and thiocyanate at 100°, and with the transport numbers of nitric acid. From the last section it appears that the ratio of the velocity of the anions to that of the hydrogen ion is several per cent. larger at very small concentrations than at moderate concentrations, and not constant for all solutions more dilute than 0.05 normal, as is usually assumed.

Prof. Jones, of the Johns Hopkins University, has for a considerable number of years busied himself with the study of solutions, especially from the standpoint of the so-called hydrate theory, which in its present aspect differs greatly from the theory which went under that name some fifteen or twenty years ago. In this communication Prof. Jones and his co-workers give the results of their investigation of the conductivity and viscosity of certain electrolytes in water, methyl alcohol, ethyl alcohol, acetone, and in binary mixtures of these solvents. The connection between the fluidity of a conducting solution and the value of its electric conductivity has long been recognised, but comparatively little detailed experimental work has been done on the subject, so that the present research, which shows the close parallelism between the two properties, not only for aqueous, but for other solutions, is of much interest and value. The problem of the variation of conductivity with change of composition of the solvent is extremely complex, but the authors may be said to have laid a safe foundation for the theoretical treatment of the subject.

THE TUBERCULIN TEST FOR CATTLE.

THE unsatisfactory nature of the tuberculin test for cattle is emphasised in two articles published in the "Live Stock Journal Almanac" for 1908. Mr. Bruce remarks that when an animal reacts there is no indication whether the case is serious or not; that an animal which reacts freely may, when tested a month or two later, fail to do so; that change of place, of companionship, and of diet, the advent of oestrus, or, in fact, anything calculated to excite the animal or upset its digestive system, may render the test abortive.

Mr. Thornton records that testing cows in calf is apt to bring on abortion, and adds that in Germany the test is considered untrustworthy, because of the number of slaughtered animals proved to be tuberculous which have passed the test, and the number in which no tubercle could be found which have been condemned by the test. He concludes, however, with the resignation common among breeders when dealing with such matters:—"The test is naturally upheld by many veterinary surgeons, and there is not much probability of it being discontinued," as members of the profession are generally selected as advisers to the Boards of Agriculture in the colonies and foreign countries, and he might have added in this country also.

With such facts before them, with the knowledge that the disease is not necessarily hereditary, that it is by no means so infectious as has been supposed, and that it is not so largely responsible for the spread of tuberculosis among human beings as we were at one time led to believe, one can hardly blame breeders if they show unwillingness to accept the doubtful blessing of the tuberculin test.

In an article on hybrids, Mr. C. T. Davies complains that the term hybrid is often loosely applied by Mendelians and other experimentalists who have little knowledge of practical breeding, to the offspring of two varieties sprung from the same stock. He points out that "cross-breeds" is the term practical breeders use for such produce, while "hybrid" is used to designate the progeny of two distinct species. He expresses the hope that biologists will adopt the ancient form of nomenclature, and so avoid confusion in the minds of those of their readers who are practical men.

UNIVERSITY AND EDUCATIONAL INTELLIGENCE.

LONDON.—In consequence of the incorporation of University College in the University, certain professors of the college will in future be entitled professors in the University of London, and will enjoy the status of appointed teachers. These include Profs. Trouton (physics), Oliver (botany), Hill (zoology), Starling (physiology), Thane (anatomy), Cushny (pharmacology), and Cormack (mechanical engineering). Sir William Ramsay, K.C.B. (general chemistry), and Prof. Norman Collie (organic chemistry) have been appointed teachers of the University for some years.

The announcement that the governing body of the Imperial College of Science and Technology at South Kensington has decided in principle on the appointment of a principal officer of the college has been received with much interest. The post will be an important one, as the resources of the college are considerable, and great developments are expected during the next few years. It is a curious coincidence that two principal officers should be required at the same time at South Kensington, the one at the University and the other at the Imperial College.

Among the advanced lectures in science to be delivered, in connection with the University, during the first term of this year are the following:—A course of eight lectures on "Grasses: their Structure, Biology, Distribution, and Classification," by Dr. Otto Stapf, at University College, on Mondays, beginning on January 27. Eight lectures on "Intra-cellular Enzymes," by Dr. H. M. Vernon, at the University Physiological Laboratory, on Tuesdays, beginning on January 14. Eight lectures on "The Chemical Constitution of the Proteins," by Dr. R. H. Aders Plimmer, at University College, on Wednesdays, beginning on January 22. Eight lectures on "The Chemistry of the Fats and Carbohydrates and some other Constituents of the Animal Body," by Dr. S. B. Schryver, at University College, on Fridays, beginning on January 24. Four lectures on "Tissue Respiration," by Dr. T. G. Brodie, F.R.S., at King's College, on Mondays, beginning on January 20. Two lectures on "The Physiology of the Emotions," by Dr. F. W. Mott, F.R.S., at King's College, on Mondays, beginning on February 17. Two lectures on "Degeneration and Regeneration of Nerves," by Prof. W. D. Halliburton, F.R.S., at King's College, on Mondays, beginning on March 2. Eight lectures on "The Physiology of Muscular Work," by Dr. M. S. Pembrey, at Guy's Hospital Medical School, on Thursdays, beginning on January 16. Eight lectures on "Inheritance in its Physiological and Pathological Aspects," by Dr. W. Bulloch, and Messrs. G. P. Mudge, M. Greenwood, and A. Baot, at the London Hospital Medical College, on Wednesdays, beginning on January 15. Four lectures on "The Circulatory System of Reptiles," by Mr. F. E. Boddard, F.R.S., at University College, on Mondays, beginning on January 20. The reader in meteorology, Dr. W. N. Shaw, F.R.S., will resume his lectures on "Meteorological Organisation and Methods of dealing with Meteorological Observations," at the Royal College of Science, on Monday, January 13.

By the death, on December 24, of Lady Pearce, widow of Sir William G. Pearce, Trinity College, Cambridge, becomes entitled to a sum of more than 400,000.

We learn from *Science* that the National Educational Association of the United States has appointed a representative committee to investigate the entrance requirements to the technical schools of the country, and to consider the question of establishing uniform entrance requirements.

The annual meeting of the Geographical Association will be held at 3 p.m. on Wednesday, January 8, at University College, Gower Street, W.C. The president, Mr. Douglas W. Freshfield, will give an address, Major C. F. Close will deliver a lecture on map projections, and there will be a lantern exhibition of views of the Rhine Gorge by Mr. B. B. Dickinson.

The Incorporated Association of Headmasters will hold its annual general meeting on January 9 and 10 at the

Guildhall, E.C. The agenda paper is mainly occupied with administrative questions, and we observe that a committee is suggested for considering the medical inspection of pupils attending secondary schools. The University of London and the northern universities are urged to come to terms for the mutual recognition of their matriculation certificates. Mr. E. J. Simpson will move a resolution in favour of the inclusion of a paper on elementary physics amongst the optional papers of the northern matriculation.

At the winter meeting of the College of Preceptors, lectures will be given on a rational comparative method of teaching geography, by Dr. Herbertson, on January 7 and 8, and the subject of geometry will be dealt with by Mr. J. Harrison, of the Royal College of Science, on January 15. During the course of the meeting there will be several lectures on psychology, personal hygiene, and the use of the voice.

SOCIETIES AND ACADEMIES.

LONDON.

Faraday Society, December 17, 1907.—Dr. F. Mollwo Perkin, treasurer, in the chair.—A physico-chemical study of the complex copper glycocoll sulphates: J. T. Barker. The paper deals with the constitution of the blue solution formed when glycocoll is added to copper sulphate solution. It is probable that the concentration of the cuprions has been lowered by the formation of complex cupri-glycocoll kations, and experiments are described to investigate this question.—The discovery of the alkali metals by Davy: the bearing of the discovery upon industry: Dr. F. Mollwo Perkin. After a short biographical sketch, the author refers to Davy's early experiments on galvanism, which began in 1800 and culminated in 1807 in the electrolytic decomposition of the fused alkalis, caustic soda, and caustic potash. Davy's experiments are described in detail, and it is shown that the E.M.F. of his battery must have been about 220 volts, and the current he used something under 1 ampere. The subsequent experiments on the decomposition of the alkaline earths, by which calcium, strontium, barium, and magnesium in the form of amalgams were obtained, are then described. The second part of the paper deals, among other matters, with the industrial manufacture by Wöhler in 1827 of potassium, by Ste. Claire Deville in 1854 of sodium, with Watt's suggestions (1851) for electrolytically fused sodium chloride, with Castner's chemical sodium process (1886) and his electrolytic process (1890), Rathenau and Suter's sodium process, Becker's process, and the process of Darling, who electrolysed fused sodium nitrate, using porous partitions.

Geological Society, December 18, 1907.—Sir Archibald Geikie, K.C.B., Sec.R.S., president, in the chair.—Some recent discoveries of Palaeolithic implements; Sir John Evans.—The author refers to some recent discoveries of Palaeolithic implements on the southern borders of Bedfordshire and in the north-western part of Hertfordshire. In addition to the discovery of a Palaeolithic floor at Caddington brickfield, at between 550 and 500 feet above sea-level, implements have since been found on the surface of the ground at 600 and 760 feet respectively; while a good ovate implement was found in thin, water-laid material, at 651 feet O.D. In Hertfordshire, Palaeolithic implements have been found at Great Gaddesdon, at a brickfield about 1½ miles north-east of Hemel Hempstead, and at Bedmond, 2 to 2½ miles south-east of the last locality. The drifts which cap the hills in north-west Hertfordshire seem to be of very variable origin; and a great part of the material is derived from clay-deposits of Eocene age, but little *remaniés*. It seems to the author that it is safest not to invoke river-action for the formation of the high-level deposits, which extend over a wide area and are in the main argillaceous and not gravelly or sandy in character, but to adopt Mr. Worthington Smith's view that in early times lakes or marshes existed in these implementiferous spots, the borders of which were inhabited by Palaeolithic man. The evidence that he has brought forward as to the implements having, in some of the Caddington pits, been manufactured on the spot, most fully corroborates this

view.—A deep channel of Drift at Hitchin (Hertfordshire): **W. Hill**. Evidence is given, from nine borings running along a line slightly west of north from Langley through Hitchin, of the existence of a channel of considerable depth, now filled with Drift, occupying the centre of an old valley in the Chalk-escarpment, which may be called the Hitchin Valley.

PARIS.

Academy of Sciences, December 16, 1907.—**M. A. Chauveau** in the chair.—The action of nitrous acid upon allylamine: **Louis Henry**. The interaction of allylamine hydrochloride and sodium nitrite gives allyl alcohol only. Acetone was looked for, but no trace of any isomer appears to be formed in this reaction.—Report by **M. Bertin** upon a memoir entitled "The Study of the Movements of Water which can be produced in Contact and in the Neighbourhood of a Plane Vertical Wall," by **MM. Fortant and Le Besnerais**.—Observations of the phenomena of Saturn's ring made with the bent equatorial of 32 cm. aperture at the Observatory of Lyons: **J. Guillaume**.—Laplace's transformation and persistent conjugate systems: **D. Th. Egoroff**.—The theory of matrices: **M. de Séguier**.—Infinitesimal transformations and adjoint functions: **N. Saitzkow**.—Differential equations of the third order with fixed critical points: **J. Chazy**.—Flame spectra obtained by the electrical method: **G. A. Hemsalech** and **C. de Watteville**. The present paper deals with an application of a process previously described, and is especially adapted for the examination of salts of the rare earths. The salt is incorporated with either boric acid or a mixture of asbestos and sodium silicate, and the whole placed in the hollow of a carbon rod forming the positive pole of an electric arc, the arc being enclosed in a glass globe. A current of air is led into this vessel, and is then allowed to flow to the burner. Finely divided particles of the salt are thus introduced into the flame of a Bunsen burner, and 1 gram of the salt is sufficient to show the flame spectrum for five hours continuously.—The Audiffren refrigerator: **MM. Audiffren and Singrun**. A suitable gas is liquefied in the compressor, and the liquid allowed to evaporate in the refrigerator, the special advantage of the arrangement (a diagram of which is given) being that both the compressor and refrigerator are enclosed in an air-tight vessel, only a single stuffing box carrying the pulley through which the whole is driven communicating with the outside air. The pump is driven by the action of gravity on a heavy piston, and it is impossible for the pressure to rise above a figure fixed by the weight of the piston.—Phosphorescence at low temperatures: **Joseph de Kowalski**. Solutions of nitrates of the rare earths in alcohol become strongly fluorescent at the temperature of liquid air. For the erbium solution the tint is green, greenish-yellow for the samarium solution, and violet for the solution of nitrate of neodymium. Alcoholic solutions of phenanthrene, anthracene, and anthraquinone behave similarly. In all cases the substance was previously exposed to a strong ultra-violet light from a quartz mercury arc lamp.—The formation of ozone by the action of the silent discharge at low temperatures: **E. Briner** and **E. Durand**. At the temperature of liquid air the vapour pressure of liquid ozone is practically zero, and it has been found possible integrally to transform oxygen into ozone. For a given expenditure of electrical energy the maximum yield of ozone was obtained with a pressure of oxygen of 100 mm. of mercury. The authors point out that the dangers of explosion of the liquid ozone are much reduced if care is taken to remove all traces of grease from the ozoniser by washing with chromic acid mixture before use.—The hydrolysis of iron perchloride. The function of hydrochloric acid: **G. Maifitano** and **L. Michel**. The experiments described by the authors appear to be best explained by the hypothesis that the constitution of the colloid is formed at the expense of the products of hydrolysis or of complex ions.—The solubility of graphite in iron: **Georges Charpy**. The results given in this paper form an additional argument for considering that the solubility of graphite in iron decreases regularly with the temperature, and give a value of 1 per cent. as the most probable value for the solu-

bility in pure iron at 1000° C.—An attempt at proving certain relations between the atomic weights of the elements: **M. Delauney**. The values of the atomic weights may be represented in the form A^2/n , where A and n are two whole numbers.—The gases occluded in steels: **G. Belloc**. The amounts of gas given off are in close relation with the critical points of iron. The gases consist of carbon dioxide, carbon monoxide, hydrogen and nitrogen, and each gas is characterised by a particular temperature of evolution. The distribution of the gases is very irregular in the different layers of the metal.—The extraction of the gases contained in metals: **O. Boudouard**. It is an extremely difficult matter to extract the whole of the gases contained in iron and steel, a third heating to 1100° C. in a vacuum still yielding some gas. The accidental breakage of a porcelain tube in these experiments showed that iron clearly commences to volatilise in a vacuum at 900° C., this effect being quite marked at 1100° C.—The qualitative examination of ciders for tartaric acid: **G. A. Le Roy**. The method is based on a colour reaction with a solution of resorcinol and sulphuric acid.—Syntheses by means of the mixed organo-metallic derivatives of zinc. The constitution of the β -acetoxyl-ketones: **E. E. Blaise**.—The preparation of the cyanides of methyl and ethyl: **M. Auger**. An aqueous solution of potassium cyanide can be employed with advantage as regards yield in the preparation of the nitriles.—Aromatic alcohols. Some new reactions: **R. Fosse**.—Some new Euphorbiaceæ from central and western Africa collected by **M. Auguste Chevalier**: **M. Beille**.—Variations in *Papaver Rhoeas*: **L. Baringhem**.—The existence of a peroxidase in dried seeds: **Brocq-Rousseu** and **Edmond Gain**. One or more peroxidases have been found to be generally present in a large number of dried seeds examined by the authors. This peroxidase does not exist in the seed indefinitely, but depends on the age of the seed.—The action of a magnetic field of high frequency on *Penicillium*: **Pierre Lesage**. In magnetic fields of high frequency the growth of the mould is accelerated, but this effect is indirect, since it is due, at any rate to a large extent, to the heating of the wires of the solenoid.—The origin of anthocyanine deduced from the observation of some parasitic insects of leaves: **Marcel Mirande**.—The marine migrations of the common trout: **A. Cligny**. The parasitic castration of male star-fish by a new infusoria, *Orchitophrya stellarum*: **Casimir Cépède**.—The variations of the length of the intestine in the frog: **Emile Yung**.—The action on the heart of certain metallic ions introduced into the organism by electrolysis: **Jean Gautrelet**.—The presence of Schaudinn's treponemes in the appendix of a hereditary syphilitic fetus: **Ch. Fouquet**.—The possibility of establishing a true diagnosis of death by radiography: **Ch. Vaillant**.—A case of modification of a *thalweg* by the intervention of a volcanic intrusion (Sardinia): **M. Deprat**.

December 23, 1907.—**M. A. Chauveau** in the chair.—The president announced the deaths of **M. Jansen** and **Lord Kelvin**.—Observation of the transit of Mercury across the sun, November 13-14, 1907, at the Observatory of Aosta, Italy: **M. Amann**. Times of the four contacts are given, with remarks on the formation of the black ligament, luminous point, and rings.—The compensation of an electromagnet compass for armoured blockhouses and for submarines: **Louis Dunoyer**.—Liquid dielectrics: **Louis Maicé**.—The conditions of maximum yield for telephonic apparatus: **Henri Abraham** and **M. Devaux-Charbonnel**. The problem attacked in the present paper is as follows. Accepting the telephonic apparatus at present in use, are the various elements, the transformer, the resistance of the bobbin of the receiver, &c., chosen so as to furnish the maximum effect in the transmission of speech? The theoretical investigation leads to the conclusion that the receiving instruments should have a resistance of 100 to 200 ohms, and the transformation ratio should be near 6 or 7. An examination of the transformers in actual use in telephone work showed an efficiency of only 60 per cent., and with this efficiency the transformers are too small for the work.—The application of the method of limiting densities to organic vapours:

Ph. A. Guye. From an examination of the experimental work of Ramsay and Steele on the densities and compressibilities of organic vapours, the author concludes that neither the parabolic extrapolations of Daniel Berthelot nor the graphical extrapolation of measurements of compressibility allows of the rigorous verification of the principle of limited densities.—The influence of temperature on the optical properties of dissolved bodies: **C. Chêneveau.** The index of refraction of a dissolved body varies only slightly with the temperature; the variation of the optical constant or the molecular refractive power of a dissolved substance under the influence of temperature appears to arise more especially from the change of volume of the solution, and appears to be produced in the same sense as the change of temperature.—The detection and estimation of nickel in the presence of any quantities whatever of cobalt, iron, and manganese: **Enum. Pozzi-Escot.** The nickel is precipitated as a double molybdate of nickel and ammonium. No test analyses are given.—The nature of some phosphorescent elements and metal-elements of Sir W. Crookes: **G. Urbain.** Starting with definite mixtures in varying proportions of pure terbium and gadolinium, the author has been able to reproduce many of the phosphorescent spectra attributed by Sir W. Crookes to separate elements.—A new chromium sulphate: **Paul Nicolardot.** The influence of acids and bases on the fixation of acid and basic colouring matters on wool: **L. Pelet-Jolivet** and **N. Anderson.** Details of the amounts of an acid and a basic dye taken up by wool in presence of varying amounts of hydrochloric, sulphuric, and phosphoric acids are given, and it is claimed that the results are in accord with the hypothesis of contact electrification, and agree with the colloidal theory of dyeing.—Glycidic ethers and aldehydes in the naphthalene series: **Georges Darzens.**—An isomer of sparteine, isosparteine: **Charles Moureu** and **Amand Valeur.** A description of the preparation of the base, its dichlorohydrate, chloroplatinate, hydriodide, and picrate. It forms a bi-tertiary saturated base, and the methyl group is not attached to the nitrogen.—Observations on the formation of the aleurone grains during the ripening of the seed: **J. Beauverie.**—Observations on the production of chlorophyll in the higher plants at different luminous intensities: **W. Lubimenko.** An important fact which appears from this work is that the best illumination for the production of chlorophyll is lower than the maximum luminous intensity of daylight. A green plant can adapt itself to a feeble light by increasing its production of chlorophyll.—The constancy of composition of plant juices obtained by successive extractions: **G. André.**—The action of tyrosinase on some substances resembling tyrosine: **Gabriel Bertrand.** Only those substances examined which contain a phenolic hydroxyl group proved to be oxidisable by a solution of tyrosinase. The length and nature of the lateral chain appeared to have only a secondary influence, provided that the chain was not too strongly acid or basic.—The excito-secretory action of the internal branch of the spinal nerve on the stomach and pancreas: **F. X. Lesbire** and **F. Maignon.** The internal branch of the spinal nerve of the pig contains, not only motive fibres, but also secretory fibres, the centrifugal fibres of the vagus.—Does the radiography of the abdominal organs permit of the diagnosis of true death? **M. Bécère.** Although the radiography of the abdomen is capable of giving assistance in the differential diagnosis of apparent and true death, the results cannot be absolutely relied upon.—The physiological properties of tubercle bacilli which have been submitted to the action of chlorine: **MM. Moussu** and **Goupil.** These chlorinated bacillary products have distinctive toxic properties, easily appreciable in healthy subjects. The thermal reaction provoked differs from that of tuberculin.—Contribution to the study of the influence of traumatism on the localisation of tuberculosis. Results of articular traumatism in rabbits tuberculised by the digestive canal: **S. Rodet** and **M. Jeanbrun.**—The Allier in Miocene times. A deposit of Miocene vertebrates near Moulins: **Ph. Gligoaud.**—The fossils near the tile works of Soumailles, in the commune of Pardailhan: **G. Vassour.**—The Agout, a tributary of the Aude, and the valley of the Lhers mort: **J. Blayac.**—Researches on the variations of the terrestrial potential: **Albert Nodon.**

DIARY OF SOCIETIES.

- FRIDAY, JANUARY 3.**
GEOLOGISTS' ASSOCIATION, at 8.—On the Zones of the Chalk in the Thames Valley between Goring and Shiplake: **C. P. Chatwin** and **T. H. Withers.**
- MONDAY, JANUARY 6.**
ARISTOTELIAN SOCIETY, at 8.—Prof. James's "Pragmatism": **G. E. Moore.**
- VICTORIA INSTITUTE,** at 4.30.—The Influence of the Glacial Period upon the Early History of Man: **Rev. G. F. Wright.**
- SOCIETY OF CHEMICAL INDUSTRY,** at 8.—Preparation of Paratoluidine from mixed Toluidines by means of Paratoluidine Hydrate: **R. J. Friswell.**—The Determination of Small Quantities of Bismuth: **H. W. Rowell.**
- WEDNESDAY, JANUARY 8.**
JUNIOR INSTITUTION OF ENGINEERS, at 8.—Recent Improvements in Electric Conduit Traction Construction: **Fitz Roy Ross.**
- GEOLOGICAL SOCIETY,** at 8.—On the Application of Quantitative Methods to the Study of the Structure and History of Rocks: **Dr. H. C. Sorby, F.R.S.**—Chronology of the Glacial Period in North America: **Prof. G. F. Wright.**
- THURSDAY, JANUARY 9.**
INSTITUTION OF ELECTRICAL ENGINEERS, at 8.—Cost of Electrical Power for Industrial Purposes: **J. F. C. Snell.**
- FRIDAY, JANUARY 10.**
ROYAL ASTRONOMICAL SOCIETY, at 5.

CONTENTS.

	PAGE
The Inheritance of "Acquired" Characters. By A. D. D.	193
Problems of Vision	193
A Lancashire Flora	194
Seleology and General Astronomy. By W. E. Rolston	195
Our Book Shelf—	
West: "The Climber's Pocket Book. Rock Climbing Accidents, with Hints on First Aid to the Injured, some Uses of the Rope, Methods of Rescue and Transport"	196
Porter: "What Rome was Built with. A Description of the Stones employed in Ancient Times for its Building and Decoration"	196
Kingzett: "Nature's Hygiene and Sanitary Chemistry."— C. S.	196
Vanderlinden: "Etude sur les Foudroiemens d'arbres Constataés en Belgique pendant les Années 1884-1906"	197
Douglas: "The Laws of Health. A Handbook on School Hygiene."— R. T. H.	197
Letters to the Editor:—	
The Wehnelt Kathode in a High Vacuum.— Prof. O. W. Richardson; F. Soddy	197
British Association Seismology.— Prof. John Milne, F.R.S.	198
The Photoelectric Property of Selenium.— Richard J. Moss; Dr. Sheiford Bidwell, F.R.S.	198
Echelon Spectroscope.— H. Stansfield	198
A Point in the Mathematical Theory of Elasticity.— H. M. Martin	198
Lord Kelvin: an Appreciation. By J. L.	199
Lord Kelvin and the University of Glasgow	200
Fluctuations in Himalayan Glaciers. (Illustrated) By Prof. T. G. Bonney, F.R.S.	201
Tidal Investigations in Canada. By G. H. D.	202
Education and Research in India	202
Notes	203
Our Astronomical Column:—	
Astronomical Occurrences in January	208
Daniel's Comet, 1907d	208
Ephemeris for Encke's Comet	208
Absolute Scale of Photographic Magnitudes	208
Annual Astronomical Publications	208
The Canyon Diablo Meteorites	208
The Stresses in Masonry Dams. (Illustrated.) By Prof. E. Brown	209
The Ethnology of Africa	211
The Place of the Laboratory in the Training of Engineers. (Illustrated.) By Prof. A. L. Mellanby	211
American Investigator on Electrolytic Conductivity	213
The Tuberculin Test for Cattle	213
University and Educational Intelligence	214
Societies and Academies	214
Diary of Societies	216

THURSDAY, JANUARY 9, 1908.

THE HISTORY OF AERONAUTICS.

Histoire de la Navigation aérienne. By W. de Fonvielle. Pp. 271. (Paris: Libraire Hachette et Cie., 1907.)

THE subject of aerial navigation is steadily developing into one of importance. Invention in this line is progressing so rapidly that the expert who wishes to be up to date must perforce be busy with much new literature. The work before us, by so well-known an aeronaut as M. de Fonvielle, will, then, be eagerly sought for. The student who expects to receive full information on all the recent developments may, however, feel some disappointment when he has looked through the book, since, out of its 270 pages, only some forty are devoted to the 'very important' work which has been accomplished during the last ten years. The rest of the book is historical, throwing, no doubt, much new light on certain points, but, as a whole, containing nothing of importance that is not to be found in older works.

The first chapter deals with the soap bubbles of Tiberius Cavallo, a story well known to Englishmen who have read that savant's most interesting book, "The History and Practice of Aërostation," which was published in London so long ago as 1785. In June, 1782, Mr. Cavallo read a paper before the Royal Society, in which he described how he had attempted to fill a light paper bag with hydrogen, in order to make it float in the air, but found it impossible to retain the "inflammable air," and how he then managed to blow out soap bubbles with hydrogen which rose in the air. In the following year both hot-air balloons and gas balloons were invented in France, and the accounts of them are described by M. de Fonvielle in following chapters. Elongated "dirigible" balloons, worked by hand, were designed very soon after the first ascents, but, of course, proved of little practical use.

The chapters on the first scientific ascents refer to those of Robertson, Gay-Lussac, Barral, and Green, but the better-known and more complete work of Glaisher and Coxwell is not more than touched upon in a following chapter.

The chapter on "Les Ballons-sondes" contains much that may be of interest to modern meteorologists, since this means of studying the atmosphere is now so much employed.

Three chapters are devoted to ascents during the siege of Paris, and one to aeronautical photography, but perhaps the most complete and interesting accounts in the book are those of the *Lebaudy* and other dirigible airships. It was in November, 1902, that the first free ascent was made with that vessel, which has now proved itself to be the first really practical aerial machine. Many more trials are described, including one on July 24, when 98 kilometres were covered; on November 12, when the airship travelled 60 kilometres to Paris; and on July 3, 1905, when a journey of 96 kilometres was performed in 3 hours 21 minutes.

The last chapter, on the development of aerial navigation, is somewhat disappointing, for after referring to the *Patrie* and the *Ville de Paris*, the two most recent practical airships in France, it recounts shortly what has been attempted in this line in other countries, but makes no reference to the important experiments recently made with the "heavier-than-air" type of machine.

As a history the work is not very satisfactory, since it jumps to and fro from period to period, and anecdotes are frequently narrated without specifying the dates.

The book is fully illustrated, but though they include some reproductions of photographs of recent events, by far the greater number of the illustrations are from woodcuts which have already done service in "Travels in the Air" (published in 1871) and other older works. We must take strong objection to some of these old blocks being reproduced with new titles, such, for instance, as that on p. 185, entitled "Les Concours de Vincennes en 1900," and that on p. 201, "Ballon couvert de neige . . . ascension de l'Aéro Club," both of which appeared in the above-named book; and especially that on p. 139, "Descente de Hoste en Angleterre," which appears in "Travels in the Air," p. 307, as "Descent of the *Neptune* at Cape Griznez." As this picture is a landscape with cliffs and a lighthouse, it cannot faithfully represent a scene on the English coast as well as one on the other side of the Channel!

TREATMENT OF HOME-WOODS.

The Garden Beautiful: Home-woods and Home Landscape. By William Robinson. Pp. xii+170. (London: John Murray, 1907.) Price 7s. 6d. net.

THE author's expressed object in writing this book was to induce people fortunate enough to possess woodlands to make them attractive and accessible. Having already written the "English Flower Garden" and the "Wild Garden," he is careful in this case to point out that just as in the latter book his purpose was not to destroy the flower garden, so in the present instance the arguments in favour of beautifying the home-woods are intended to persuade proprietors "after thought of the needs of a true garden, to think more of their woods from æsthetic and other points of view."

We are quite in sympathy with Mr. Robinson when he states that there are hundreds of acres of beautiful woods in his district never seen by anyone but the gamekeeper. Yet how delightful the effects that may be obtained by opening up such woods, in a manner that paths are made available for foot visitors at all seasons of the year! On most estates no such thing is done, but we have in our mind several instances that afford striking testimony to the deprivations voluntarily or ignorantly suffered by those who maintain the woodlands as a closed book, so to speak, to all but sportsmen. One of these is at Keele Hall, in Staffordshire, the present residence of the Grand Duke Michael of Russia, where the woods, extending for a mile or more beyond the pleasure grounds, were

laid out with suitable paths about forty years ago by the late Ralph Sneyd, uncle to the present owner of the estate.

The idea in carrying out such work should be that of bringing the most picturesque portions of the wood into view, and the paths should be arranged accordingly. It would be contrary to the spirit of the thing to try and make the woodlands a kind of pleasure-ground, for the woods are capable of yielding effects perfectly distinct from those which may be obtained from a pleasure-ground. No great amount of planting need be done, but by this statement we do not mean that regard for a supposed principle need prevent one from planting decorative shrubs, trees, or bulbs in positions where suitable sites are available for them, and the effect can thereby be greatly improved. In many situations where close planting has caused trees to develop fine, straight stems or trunks, there is no need for any under-shrub to complete the scene, for the lover of trees will have his delight in viewing the magnificent stems, often devoid of branches for twenty, or even thirty, feet from the ground.

But it is necessary, for change of scene, that in some places there should be a dense undergrowth of an evergreen shrub, such as the rhododendron, which is capable of thriving and even flowering well in comparative shade. The author of the present work rightly insists on the necessity of obtaining rhododendrons on their own roots for woodland planting, as they are usually capable of succeeding better than grafted plants, especially if the grafts have been worked on stocks of *R. ponticum*. Many gardeners have the idea that the old and somewhat unattractive *R. ponticum* is the hardiest of all rhododendrons, but this is erroneous. Some of the North American kinds are much hardier, and their effect when in flower is brilliant. Mr. Robinson specially recommends a variety known as "Cunningham's White," a most hardy plant of vigorous constitution, and bearing flowers of a rosy-lilac colour in bud, gradually becoming paler as the flowers expand. Other suitable species for forming undergrowth of a similar nature would include *Berberis aquifolium* (the evergreen barberry), *Ligustrum ovalifolium* (common privet), *Laurus nobilis*, *Gaultheria Shallon*, species of *Hedera* (ivy), *Bambusa* species, also common briars, bracken and furze, &c.

When once the owner of a wood, however, determines to make it accessible and attractive, he will soon discover various ways in which the views from the paths may be improved without interfering with the character of the wood itself. The sides of the paths can easily be planted with attractive, low-growing shrubs, and the scope for securing spring effects from flowering bulbs will be almost infinite. The bulbs from the forcing houses need never be thrown away, for suitable situations for them will present themselves in numerous instances, and snowdrops, crocuses, bluebells, and even the cheery little cyclamens may be planted in thousands.

The author reproduces two chapters from "The English Flower Garden," and then in subsequent chapters goes on to deal with the evergreen and de-

ciduous trees of the northern forest, the best of native and European trees for the British Isles, how to produce wood and covert from seeds, and many other details connected with the subject, there being in all thirty-three chapters. We cannot agree with the suggestion on p. 76 that trees growing in isolated positions on lawns have their roots robbed by the grasses! in anything like the measure that obtains when the trees are growing together in a plantation. Mr. Robinson's plea for the use of English names in garden literature we regard as unfortunate, unless the botanical names are employed also, as the use of popular names alone usually leads to the greatest confusion.

WATER SUPPLY.

Clean Water and How to Get It. By Allen Hagen. Pp. x+178; illustrated. (New York: John Wiley and Sons; London: Chapman and Hall, Ltd., 1907.) Price 6s. 6d. net.

THIS is probably no engineering topic at the present day of more striking importance to the public welfare than that relating to the supply of pure water for domestic purposes to large centres of population. Health, physical fitness, comfort and general well-being are all bound up in the solution of a problem which becomes daily increasingly difficult, and, at the same time, increasingly urgent, with the rapid growth and development of manufacturing towns, quite apart from the consideration of its equally essential application to the smallest hamlet and to the individual. An age which no longer recognises disease and degeneration as the unalterable and inscrutable decrees of a mysterious Providence, but as evils to be resolutely combated, with every hope of a successful issue, cannot for one moment tolerate the idea of polluted sources and germ-ridden channels for its supplies of water—that element so indispensable to existence and so inseparable a constituent of nature itself.

Any publication, therefore, which tends to throw additional light on the subject, or which collates and classifies data and information already acquired for the use of those engaged in the prosecution of water-works, must be readily welcome. Mr. Hagen's book belongs to the latter class, and his object has been to set down some useful facts and principles for the guidance of those who have had no previous experience in the matter, and yet who are called upon, in connection with civic and urban duties, to participate in the control and distribution of water for their respective districts. The book is avowedly not intended for the expert, though even he may find some serviceable data among its pages. It is for the beginner and the "man in the street," in order that they may thereby be led to understand and appreciate something of the rudiments of a science of such vital concern to themselves and their fellow citizens.

Written exclusively from an American standpoint and based entirely on American practice, it is difficult on this side of the Atlantic to offer very effective criticism of its contents. Conditions here differ in so many respects as to afford little scope for useful com-

parison. Thus in this country we have no cases of towns corresponding to the Great Lake cities—Chicago, Cleveland, Buffalo, Detroit, Milwaukee and Duluth—drawing their water supplies from the same limited area into which their sewage is discharged. The risk of pollution is so abundantly evident that it is not surprising that Chicago has attempted to minimise the evil by diverting her sewage outfall, at considerable cost, into the Mississippi River. The wonder is that the example has not been copied in other cases.

Another strikingly distinctive feature is the enormous excess of supply *per caput* over that generally provided in this country. London and Liverpool are each content with less than forty gallons per head daily, whereas ten large American cities severally and individually exceed a demand of 100 gallons per head. New York takes 129 gallons; Boston, 151 gallons; Chicago, 190 gallons; and Pittsburg, 250 gallons. The discrepancy is tremendous. One feels that Mr. Hagen has hardly put it sufficiently strongly when he remarks that, "taking it right through, probably one-half the water supplied to American cities is wasted."

Mr. Hagen, in his book, first describes the various available sources of supply, viz. artificial reservoirs, small and large lakes, rivers, wells, and springs. He then discusses the chemical action of water on iron pipes and the means of effecting and maintaining the purification of stored water. There are chapters on pressure and on metering; the financial side of the subject is also considered. Altogether, the book is a most useful compendium of information relating to American methods of water supply.

VETERINARY PHYSIOLOGY.

A Manual of Veterinary Physiology. By Colonel F. Smith, C.B., C.M.G. Third edition, completely revised and in parts re-written. Pp. xvi+715. (London: Baillière, Tindall and Cox, 1907.) Price 15s. net.

AN interval of twelve years has passed between the issue of the last edition of this text-book and the present, third, edition. So many and notable have been the advances in physiology during that time that the book has had to be practically re-written; only the chapters on the senses, locomotion, and the foot stand nearly as they were. The chapter on the nervous system has been read, and some new matter added to it, by Prof. Sherrington, F.R.S., and other sections have been amplified by the cooperation of men who have special knowledge of the particular subject dealt with.

The book is not a text-book of human physiology with a little veterinary material added, but is a treatise which takes the horse as the type, and preserves that type throughout. Other animals of interest to the veterinary surgeon are not thereby excluded; the ox, sheep and pig, where differing essentially in their physiology from the horse, are fully considered. A special feature of the work is the interest it arouses in the reader; the physiology is applied to the practical requirements of the student

and practitioner, and the book is, in its way, partly a clinical manual. An appendix to many of the chapters takes up shortly the more common features of pathological interest liable to occur in the organ or organs the physiology of which has just been considered. The addition of a little pathology is, in the words of the author, meant to enforce the lesson that pathology is only physiology out of health. It certainly adds greatly to the interest of the book, and serves to emphasise the importance of a thorough understanding of the normal.

For many of the discoveries in the physiology of the horse we are indebted to the researches of Colonel Smith himself, and no one is in a better position to unfold them. This he does in the simplest and clearest language; many of his statements, indeed, throw light on processes which go on in the human body, or are at least extremely suggestive. The observations, founded on universal experience, that, in order to get a horse fit for hard work, or cattle and sheep ready for the butcher, the diets given must be strongly nitrogenous and limited only by the appetite, are quite opposed to the recent theories so strongly advocated by Chittenden. This is not the only instance where theory and practice come into opposition; the custom of watering a horse before feeding it is physiologically correct, but, according to Ellenberger, a horse, in order to derive the fullest possible nutriment from its oats, should be given hay first, then water, and finally oats. This does not accord with the English views of watering and feeding horses, which, however, as Colonel Smith says, have stood the test of prolonged practical experience.

The chapter on digestion is particularly good; the horse, ox, pig, and dog are separately considered. Occasionally one meets with statements that require further amplification; that pilocarpine is antagonistic to atropin and produces a profuse flow of saliva reads as though pilocarpine overcomes the effects of atropin, and that nicotine paralyses ganglion cells is not quite exact. The text, however, bears evidence of careful revision, and the book will prove a most valuable one to veterinary students and practitioners. Recent discoveries have been generally incorporated. Special mention may be made of the chapter on generation and development, which are particularly well treated. The work is one that can be read with interest from beginning to end, and claims the attention of all interested in veterinary work.

PERCY T. HERRING.

OUR BOOK SHELF.

The Polarity of Matter. By Alex. Clark. Pp. vii+134; illustrated. (London and Edinburgh: Gall and Inglis, n.d.) Price 3s. 6d. net.

THIS book claims to be a trustworthy text-book for the student of physics, but we cannot recommend it in this respect. Very few of the statements of fact which it contains are correctly made; and the deductions from them are supported by little consistent proof. At least, these are the conclusions to which we have come after a genuine endeavour to understand the meaning of the book. At the present time, when there has been such a rush of new facts, there is abundance of room for a book of a speculative

character. The author must not think, therefore, that we speak unfavourably of his work because of its novelty. The true explanation of physical phenomena will sound exceedingly novel, we have no doubt, when it is first put forward. It may be that in the author's mind there is a germ of an idea which deserves developing. But if he wishes this to be recognised it would be well if he were to get some friend to assist him in the process.

The main aim of the book is to reduce all "forces" to one origin; and the secret by which it is done is the recognition of the "polarity of matter." Considering the thoroughgoing attempts of Sutherland and others to explain gravitation by means of polar systems of electrons, he would be a rash man who should say that the author's idea is absolutely chimerical. Whether or not he is qualified to develop it may perhaps be learned from the following extracts:—

"When the magnet is a straight bar . . . the distance between its pole being $2a$. . . the magnetic force is $3/14$ times the gravitational force. If the magnet be bent into the form of a horse-shoe so that the distance between its poles is a , the magnetic force is $12/5$ times the gravitational force. . . . When the poles of the magnet come together the force is unity. . . ."

"The position of a fragment of iron in a magnetic field may therefore be defined as tangential to an ellipse of which the magnetic poles are the foci."

"The force of attractive interest in each of two bodies forming the poles of an electric force is a constant quantity, and when the force radiates equally in all directions its magnitude is gravity."

"In all cases of magnetisation by means of an electric current, certain waves proceed from the current by which the effect is produced. These waves are commonly called Hertzian waves."

If the seeker after novelty finds in the above extracts the particular kind of novelty for which he seeks, we cordially commend the book to him; and we wish him greater success in unravelling its meaning than we have attained.

Wild Bees, Wasps and Ants, and other Stinging Insects. By Edward Saunders, F.R.S. With numerous illustrations in the text and four coloured plates by Constance A. Saunders. Pp. xiii+144. (London: Routledge and Sons, Ltd., n.d.) Price 3s. 6d.

SINCE the death of Frederick Smith, probably no man has given more attention to the study of our British Hymenoptera Aculeata (the section of the order which contains stinging insects, such as bees, wasps, and ants, &c.) than Mr. E. Saunders. This order of insects is much less hackneyed than the Lepidoptera or Coleoptera, and Mr. Saunders's work will be very useful to beginners commencing the study of perhaps the largest order of insects of all, and also of the most interesting section, for there are only four groups of insects known which include species living in organised communities, three in Hymenoptera—bees, wasps, and ants—and only one in Neuroptera—the termites, improperly called white ants. The non-aculeate Hymenoptera, not here dealt with, are far more numerous, and are very imperfectly known or studied at present; they comprise the sawflies and gall flies, and also the ichneumons, and other parasitic insects, hundreds of which are of very small size, including among them the smallest known insects.

But it will be sufficient for most entomologists who are inclined to study Hymenoptera to follow the lines laid down by Mr. Saunders for the examination of the structure and habits of the more familiar and less difficult group of Hymenoptera Aculeata. The information given, though, of course, much condensed, is

well arranged and thoroughly trustworthy, besides being expressed in an attractive manner. The last chapter, "On Structure," with a good diagram and clear descriptions, will be particularly useful, for nothing is more troublesome to an entomologist taking up the study of an order or group of insects unfamiliar to him than the absence of a clear explanation of the terms applied to the various details of insect structure.

Das Problem der Schwingungserzeugung. By Dr. H. Barkhausen. Pp. iv+113. (Leipzig: S. Hirzel, 1907.) Price 4 marks.

THE author of this book discusses the conditions under which an instrument or piece of apparatus can produce undamped vibrations when the source of energy does not vary periodically.

The organ pipe and violin string illustrate the phenomenon in the case of vibrations produced by mechanical means. For the mathematical theory, however, electrical vibrations are the most convenient, and as the problem of creating undamped electrical vibrations is of present-day importance in wireless telegraphy, the greater part of the book is devoted to its consideration.

The first result obtained is that a necessary condition for the production of permanent vibrations is the presence of a variable alternating resistance, self-induction or capacity in the current system. The variation of the resistance may be due to external action, as in the microphone and in a new arrangement called the resonance interruptor, which is capable of giving high frequencies, or it may arise from the current flowing through the apparatus as in the electric arc.

The author makes frequent use of graphical methods, especially in the discussion of three different types of vibration which can be produced with the arc. These are investigated separately, and compared with regard to their capacities for resonance, high frequency, and performance of work. The questions of stability show that permanent vibrations can be obtained only when the interval for re-kindling after extinction increases more rapidly at first than it does afterwards. Various methods are given by which this can be ensured.

The book concludes with a chapter on mechanical vibrations, particular attention being paid to those produced by friction. On the whole, the exposition is good, and we can confidently recommend the book to those who wish to obtain a grasp of the principles of the subject. H. B.

Album de Aves Amazonicas. By Dr. E. A. Goeldi. (Para: Museu Goeldi, 1907.)

WE have been favoured with a copy of the third and final fasciculus of this superbly illustrated work, of which the first part was noticed in our issue of August 22, 1907. The present fasciculus includes plates 25-48, which are executed in the same first-class style as their predecessors, and a re-issue of the descriptions of the entire series, together with several well-arranged indices. We can add little in the way of commendation to what has been already written in our notices of the two earlier issues. Throughout the work the figures are for the most part well drawn, and coloured with such a near approximation to nature as to render the various species easily recognisable. That the work will tend to promote the study of Brazilian ornithology cannot be doubted, and the author is to be heartily congratulated on having given to the world such a splendid series of portraits of the most striking representatives of a tropical bird-fauna.

LETTERS TO THE EDITOR.

[The Editor does not hold himself responsible for opinions expressed by his correspondents. Neither can he undertake to return, or to correspond with the writers of, rejected manuscripts intended for this or any other part of NATURE. No notice is taken of anonymous communications.]

A Specific Gravity Balance for Large Rock Specimens.

The specific gravity balance represented in the accompanying illustration was devised by me some ten years ago for the determination of the specific gravity of hand specimens of rocks in the laboratory of the Geological Survey of India, Calcutta. In the ordinary form of Walker's balance the weight used on the short arm must be considerable in order to balance even a very small fragment of rock on the longer arm, and in consequence the specific gravity of an ordinary hand specimen has to be inferred from that of a small chip, which, unless the rock is of very homogeneous composition and texture, may give a very misleading result; and it is evident that if this form of balance were capable of accommodating a fairly

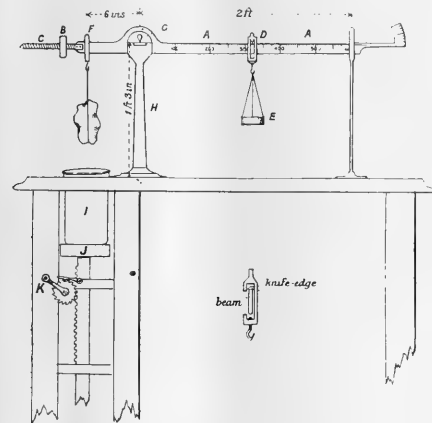

A specific gravity balance for large rock specimens. $\frac{1}{2}$ full size.

large specimen, the whole instrument would have to be immoderately large. It occurred to me that if the specimen could be substituted for the heavy weight of Walker's balance, not only would it be possible to construct a balance of moderate size by which the determination of large specimens could be made directly, but the manipulation of the specimen and of the vessel containing the water might be greatly facilitated.

This object was attained by counterbalancing the beam A (see diagram) by means of a weight B, which is made so that it runs fairly easily on the screwed rod C, attached to the shorter arm of the beam. The adjustment is made before commencing a series of determinations, after removing the sliding piece D from which the scale pan E depends (the back of this sliding piece being cut away for this purpose, as shown in the separate figure), but with the hook F for the suspension of the specimen in place. Both the frames to which the hooks are attached are supported on knife-edges, that at F being fixed to the beam, while that at D is attached to the sliding-piece, so that it can be placed at any point on the longer arm of the beam. The beam itself is balanced on a knife-edge at G, supported on grooved agate bearings let into the top of the pillar H. The beam is divided along its upper edge into millimetres, measured from the point of support at G. The dimensions

of the instrument are indicated in the diagram; it was constructed by the Mathematical Instrument Department of the Survey of India in Calcutta.

On the left-hand side of the table supporting the balance is shown an arrangement for raising and lowering the jar I, containing water. The jar is supported by a block of wood J, to which is attached a rack and pinion actuated by the handle K, a ratchet wheel and pawl enabling the jar to be fixed at any convenient height. This apparatus has been found very convenient in manipulating large specimens, and it enables one to get rid of the air-bubbles which attach themselves to the specimen when first immersed, by raising and lowering the jar two or three times before moving the scale pan.

In making a determination the knife-edge carrying the scale pan is placed at the 500 mm. division on the beam, and small shot are poured into the pan until the specimen in air is exactly balanced. The water-jar is then raised until the specimen is entirely immersed, and then the scale pan is moved to the left along the beam until equilibrium is again established, the weight in the pan remaining the same. The number of millimetres at which this occurs is noted, and the specific gravity corresponding is found at once from a table suspended near the instrument. A portion of this table is given here:—

mm.	sp. gr.	mm.	sp. gr.
300	2.500	—	—
301	2.512	—	—
302	2.525	348	3.289
303	2.538	349	3.311
304	2.551	350	3.333
—	—	351	3.355

The specific gravities corresponding to each division might, of course, be engraved on the beam, but with millimetre divisions the figures would have to be inconveniently minute. In practice the balance has been found to be very accurate, on comparison with a large balance of the ordinary description, the error only affecting the third place of decimals; and where a large number of hand specimens has to be determined, the saving in time made possible by its use is very great.

Broken specimens and small fragments of rock may be enclosed in a cage of fine copper wire, the error introduced by which can be easily calculated. In Calcutta, when the cage is in use, the error is corrected by adding 1 to the number of millimetres read when the specimen is immersed in water.

There is, of course, nothing new in the principle of this balance, but the general arrangement, especially the water-lift, is, I think, novel, and it has been found so convenient where large numbers of hand specimens have to be dealt with that I trust it may be introduced into other geological laboratories; I shall be happy to furnish more precise details of the dimensions of the instrument to any one desirous of having a similar one constructed if he will kindly communicate with me.

T. H. D. LA TOUCHE.

Kingstown, Ireland, December 7.

A Point in the Mathematical Theory of Elasticity.

I do not recollect that in Prof. Karl Pearson's recent memoirs embodying the results of tests on jelly models of dams he asserted that the distribution of stresses due to the water pressure on and the weight of a dam is entirely different in a thin slab cut from the dam from the distribution in the actual dam. In fact, Prof. Pearson used many such model slabs in an endeavour to ascertain experimentally certain stress distributions in actual dams. Prof. Pearson will doubtless be able to reply to criticisms from engineers or others regarding any statements he has made in this connection, either in his published memoirs or elsewhere: it is difficult to follow Mr. Martin's arguments (p. 198) at all points, more particularly with respect to the effects of the cancellation forces $\gamma y = F(xz)$.

It seems to me, however, that the stresses in a thin slab, due to its weight and water pressure, must be different from those in an actual dam. A dam is fixed as

rigidly as possible along its base and at its ends, and if the plan of the upper edge is originally straight there must be some horizontal displacement at the centre of the length from the line joining the abutments, quite apart from such displacement as may be due to the overturning effect of the pressure on a vertical slab. The dam resembles in some measure a built-in beam, and, recognizing this fact, some large dams have been built slightly convex on the water face.

If a balcony consisting of a plate of variable depth is rigidly supported at its ends and along one side, I imagine that the vertical displacement caused by a load at the centre and front of the free edge of the balcony could not be estimated without some regard for its end and side supports, nor could the stresses due to it be easily determined. There would be some stress along the horizontal fibres joining its ends, and the elevation of the front edge of the balcony must show contraflexure, since its ends are horizontal and the centre portion is concave upwards.

Can we deny the existence of such effects, whatever their magnitude may be, if a masonry dam is regarded as an elastic body? An engineer should be conscious of all the forces at work on a structure which he is designing, and if these forces and their effects can be correctly estimated, a design may be prepared having due regard to the physical properties of the materials employed and their liability to variation, owing to natural causes and errors of workmanship.

When the forces and their effects are in any measure uncertain, the exercise of due caution, accompanied by mature judgment based on experience, will usually lead to a successful design. It does not seem probable that a mathematical solution can be obtained for the stresses in a homogeneous isotropic dam, rigidly fixed at its ends and base, which can take account of the conditions existing in practice. The solution of the theoretical case would be of interest, but it is questionable to what extent it would be applicable to practical conditions, in which dams are not homogeneous and isotropic, and foundations and abutments are not absolutely rigid.

Engineers recognizing these facts have used a simple but approximate method of estimating the stresses in a dam, based on the flexure of beams. The solution based on the theory of elasticity, as presented by Prof. Pearson, may be nearer the truth, but it may be questioned whether this can be known to be the case in an actual dam.

E. BROWN.

Echelon Spectroscope.

FURTHER observations on the secondary bands referred to in my letter in NATURE of January 2 (p. 198) seem to indicate that they are faint spectra of a much higher order than the primary spectra.

Faint spectra of a very high order must be formed by a series of beams that have suffered two reflections at the external surfaces of the echelon. Each of these secondary beams has traversed the echelon three times, and the retardations of the beams form a series the common difference of which is seven times that for the series of beams giving the primary spectra, taking the index of refraction to be 1.5. These secondary beams would only have about one six-hundredth of the intensity of the primary beams, and I thought that the resulting spectra would be too faint to be observed until I found that the reflections that take place at the interfaces of the echelon assist in forming the same secondary spectra.

Assume that each interface reflects the same very small proportion of the light incident upon it, and neglect beams that have been reflected more than twice. Imagine the echelon being built up one plate at a time, commencing with the largest. Each plate that is put on starts a series of secondary beams and adds another term to each of the series started by the earlier plates. The retardations of each of these series have the same seven-fold common difference as the first series, and so they all help in forming the secondary spectra.

Each member of the series started by the n th plate has n times the intensity of the unit secondary beam produced from the primary beam by two interface reflections, consequently the last few steps of the echelon are much more

effective in producing the secondary spectra than the steps formed by the first few plates, and the clearness of the secondary spectra given by the echelon may be much improved by covering over, say, the first half of the whole number of steps built up.

In this way better photographs of the secondary bands have been obtained, and I hope to be able to test this explanation of their formation quantitatively.

H. STANSFIELD.

The University, Manchester, January 6.

The Photoelectric Property of Selenium.

I HAVE to thank Mr. R. J. Moss (January 2, p. 198) for the true explanation of the extraordinary increase of conductivity of a selenium bridge enclosed in an exhausted tube. The air pump employed, in the first instance, to produce the exhaustions was the mercury pump of Töpler, and it occurred to me that the mercury vapour might be objectionable. The enormous magnitude of the effect, however, induced me to ignore this vapour. The drop in resistance was finally from 61 megohms to 9.7 ohms. After seeing Mr. Moss's letter I made another bridge, enclosed it in a glass tube, and exhausted this tube with a Fleuss. The result was now an increase of resistance in the bridge from 57 megohms to 110 megohms—an increase which can be easily explained. Whether or not the exhaustion produces increased sensitiveness to light and other benefits I cannot yet say. Dr. Shelford Bidwell's conjecture that there was a short circuit in the bridge is the first explanation that naturally occurs, but from the nature of the bridge no short circuit is possible. The metallic parts are absolutely fixed, and separated by thicknesses of glass or mica sometimes amounting to 1 mm.

The result proves the undesirability of exhausting by mercury pumps in certain cases.

Oxford, January 5.

GEORGE M. MINCHIN.

Musical Sands.

IN NATURE of December 26, 1907 (p. 188), Mr. S. Skinner's recent exhibition of "singing" sand at the Physical Society is referred to. These particular sands were said to consist chiefly of angular grains. In all my investigations, which have extended over a period of many years, I have never been able to produce musical notes from any sands composed of purely angular grains; indeed, as I have frequently stated, a certain proportion of angular grains mixed with a musical sand will effectually silence it! I dealt fully with this point in my paper on musical sand published in 1888. Again, I have never yet met with purely angular grains possessing smooth and rounded surfaces—conditions which, with others, are essential in the production of music from sands. Perhaps Mr. Skinner meant subangular grains?

I do not think the explanation of the cause of the phenomenon suggested by Profs. Poynting and Thomson in "Sound" ("Text-book of Physics") meets the case. It is based on the erroneous assumption that the sand-grains are arranged as a number of equal spheres in contact. If this supposition were correct, and the condition an essential one in the production of notes, then my experiments with many sands composed of highly spherical grains (like the "millet seed," for instance) should have yielded notes of the highest quality, instead of being, as they all were, mute under the most favourable conditions.

The late Prof. Tyndall, who took a great interest in my work, and personally confirmed the results of my experiments, agreed with my conclusions, and thought hardness of grain an important consideration, believing that the loudest notes might be emitted from ruby and diamond sands—if I could get them! I am under the impression that if the theory proposed by Profs. Poynting and Thomson is tenable, it should be possible to obtain notes from comparatively soft spherical seeds (like fig, &c.), but though I have experimented with many kinds, I have not been successful in this direction. I still think my friction theory the simplest, and as many leading men of science have supported it, and no one has as yet disproved it, why may it not be retained?

Cecil Carus-Wilson.

SPORT AND NATURAL HISTORY.¹

(1) IN works of the present nature, Mr. Millais is at his best; and his best, alike with pen and with pencil, is, it is almost unnecessary to say, very good indeed. Caribou-hunting was the main object of his expedition, and in this work the author has given us an account of the local race of the reindeer which has never before been equalled, a feature of special value being a coloured plate of the animal from a sketch by himself. Some magnificent and perhaps unrivalled photographs of heads of this handsome animal are also reproduced.

Mr. Millais is never content with following in the beaten track; and during his expedition he succeeded in making his way into previously unknown tracts in the interior, where he succeeded, from a clue given by Mr. F. C. Selous, in locating a large non-migratory southern herd. It will probably come as a surprise to many of his readers that a large area of the interior of the country is still unknown, even to the Government surveyors. Here reindeer abound, these swampy tracts of the interior being, in fact, fit for nothing else than reindeer. A most satisfactory feature is that, despite an organised annual slaughter during migration, the caribou continue to increase in the island, and, in the author's opinion, are likely to do so for centuries.

Mr. Millais estimates the number of caribou in the island at 200,000. The rate of destruction is estimated as follows:—"Putting the death-rate at the highest estimate of three animals each to 4000 shooters, 12,000 would be killed out of 200,000, that is, a depreciation of 6 per cent. Now this is a much smaller rate of killing than takes place among the stags of Scotland, and they are undoubtedly on the increase."

The book is, however, by no means restricted to Newfoundland and caribou, for we have, near the middle, an interesting chapter on the author's experiences in whaling, in which the game were the blue finner and the humpback. In the course of this chapter we notice (pp. 162, 178) two different dates assigned to Svend Foyn's invention of the bomb-harpoon, the one last mentioned being correct; and at least one slip in proof-reading is observable.

The coloured plates of scenery and animals are exquisite, and ought by themselves to ensure a large sale for this charming volume; while the reproductions from photographs and pen sketches are no less admirable and interesting. As an example, we reproduce the illustration of a party of caribou swimming a lake, with Mount Cormack in the distance.

(2) In place of stirring jungle adventures and hair-

¹ (1) "Newfoundland and its Untrodden Ways." By J. G. Millais, Pp. xvi+349; illustrated. (London: Longmans, Green, and Co., 1907.) Price 21s. net.
(2) "Plagues and Pleasures of Life in Bengal." By Lieut. Colonel D. D. Cunningham. Pp. xi+385; illustrated. (London: John Murray, 1907.) Price 12s. net.

breadth escapes from tigers and wild boars, we have in this attractive and beautifully illustrated volume a series of chapters on the insect and other invertebrate (we really want a word equivalent to the Spanish *becho*, which will serve for all these creatures) life of the plains of India, followed by others on Indian trees, plants, and gardening. From preface to index the work is written in a style and with a charm which cannot fail to interest a large circle of readers; while the numerous references to details connected with the habits and environment of the various species cited serve to proclaim the author (already well known to the reading public by an earlier work on the same lines) as an accurate and painstaking observer. So graphic, indeed, are his descriptions that we can almost imagine ourselves in the veranda of a bungalow on a hot night at the beginning of the rains, surrounded by pests of many sizes and sorts, or wandering in spring through the incomparably beautiful glades of the Botanical Gardens at Calcutta.

Among the larger pests to which the author pays much attention are centipedes and scorpions; and in connection with the latter he relates how a *yogi*

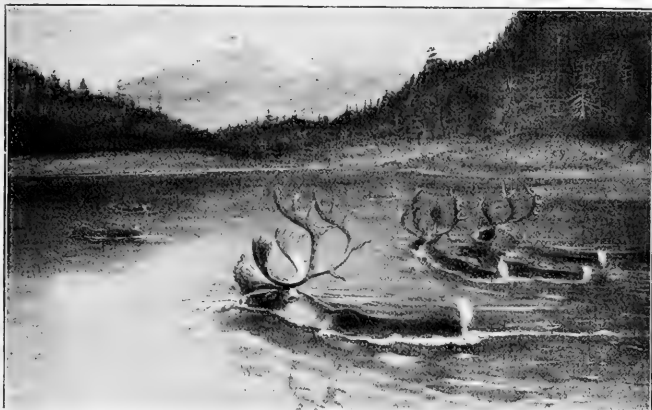

FIG. 1.—Caribou swimming a lake: Mount Cormack in the background. From "Newfoundland and its Untrodden Ways."

from Mirzapur, who had the reputation of being immune to the scorpion's sting, submitted himself to a trial in Calcutta. To make sure that there should be no "bogus" in the matter, a good supply of freshly-caught scorpions of the most venomous type was provided. After some hesitation, he allowed several of the creatures to affix themselves to his fingers, when he appeared to suffer no special inconvenience or pain, and thus demonstrated the truth of his assertions. The immunity was, in Col. Cunningham's opinion, probably due to frequent inoculation with the venom, aided possibly by an innate tendency in that direction, and the consequent development of an antitoxin, the case being, in fact, analogous to that comparative immunity to mosquito-poison which results in most persons after lengthened preliminary suffering.

Among other trials to which the resident in India is subjected, the author waxes eloquent on the difficulty of preserving books from the ravages of "silver-fish" and white ants; while he also refers to the voracity of the huge land-snails (achatins) introduced into Cal-

cutta gardens from Mauritius, and the unpleasant results which ensue if their destruction is not conducted on special lines.

Let no one, however, imagine that an Indian life has not its lighter side. What, for instance, can equal the glory of its sunsets, so graphically described by the author, or the luxuriance and beauty of its gardens, which he brings to our notice with the aid of both camera and pen? As an example of what can be done in the way of effect with foliage alone, we reproduce



FIG. 2.—Palms in an Indian Garden. From "Plagues and Pleasures of Life in Bengal."

the accompanying illustration, with which we must, reluctantly, take leave of a charming, thoughtful, and instructive work.

R. L.

"KIMBERLITE" AND THE SOURCE OF THE DIAMOND IN SOUTH AFRICA.

THE origin of the volcanic pipes of South Africa and the genesis of the diamonds contained in their "blue-ground" filling are as productive of controversy as that other geological puzzle—the source of the gold in the Witwatersrand conglomerates—the discussion of which was revived by Prof. J. W. Gregory at a recent meeting of the Institute of Mining and Metallurgy; and agreement among the disputants is as little likely to be arrived at in the one case as in the other. Quite a crop of papers on the diamond-pipes has recently appeared,¹ and a

¹ A. W. Rogers and A. L. du Toit: The Subterland Volcanic Pipes and their Relationship to other Vents in S. Africa (Trans. S. A. Phil. Soc., vol. xv., p. 61, 1904).

² H. S. Harger: The Diamond Pipes and Fissures of South Africa (Trans. Geol. Soc. S. A., vol. viii., p. 110, 1905).

³ S. Conrath: The Occurrence in Kimberlite of Garnet-pyroxene Nodules carrying Diamonds (Trans. Geol. Soc. S. A., vol. x., p. 65, 1907).

⁴ F. W. Voit: Kimberlite Dykes and Pipes (Trans. Geol. Soc. S. A., vol. x., p. 69, 1907).

⁵ F. W. Voit: The Origin of Diamonds (Trans. Geol. Soc., S. A., vol. x., p. 75, 1907).

⁶ A. L. du Toit: Geological Survey of the Eastern Portion of Griqualand West (Eleventh Ann. Rep. Geol. Com. Cape of Good Hope, p. 135, 1906).

⁷ A. Maxon: Ueber die südafrikanischen Diamantlagerstätten (Zeitsch. der deutsch.-n. geol. Gesellsch., vol. lxx., p. 70, 1907).

⁸ R. Beck: Untersuchungen über einige südafrikanische Diamantlagerstätten (Zeitsch. der deutsch. geol. Gesellsch., p. 276, 1907).

perusal of these reveals so remarkable a variation of opinion that it may perhaps serve a useful purpose to give in these columns a brief summary of the different views as to the nature of the original matrix of the diamond and the place in which it was produced, that have been put forward from time to time since the discovery of the "dry diggings" at Kimberley in 1870.

Prof. E. Cohen, who visited the diamond field in 1872, gave the first scientific explanation of the

origin of the volcanic pipes in a letter addressed to Prof. Leonhard, and published in the "Neues Jahrbuch für Mineralogie" (1872, p. 859). According to Cohen the diamond occurrences represent the centres of tuff-eruptions, whereby the greater part of the erupted material was provided by older crystalline rocks underlying the present known formations. These furnished not only the diamonds, but probably most of the accompanying minerals. Forced violently upward by volcanic explosions, the shattered rocks became pulverised, and the diamonds either survived as complete crystals

or were broken into fragments (the "splints" of the dealers). This view explains the fragmentary character of the minerals that accompany the diamond; it also accounts for the presence of so many fragments of crystalline rocks in the pipe-material ("blue-ground"), and for the strongly brecciated character of the latter. Cohen's view was subsequently somewhat modified by Chaper (Bull. Soc. Minér. de France, ii., 1879, p. 195), who found it necessary to assume a repetition of explosive eruptions in order to account for the variation in one and the same pipe of large masses of the blue ground in colour, mineral composition, richness in diamonds, &c.

On the other hand, Dunn, who wrote in 1874 (Quart. Journ. Geol. Soc., xxx., p. 54), described the blue ground as a "decomposed gabbro or euphotide"; while Maskelyne and Flight, who gave the first description of the microscopic character of the diamantiferous rock (Quart. Journ. Geol. Soc., xxx., 1874, p. 406), considered that it "was probably the original home of the diamond, possibly at the places of its contact with carbonaceous shales." These ideas were further developed by Carvill Lewis in papers read before the British Association in 1886 and 1887, and subsequently published by Prof. T. G. Bonney under the title "Papers and Notes on the Genesis and Matrix of the Diamond." After an elaborate microscopic investigation made in Prof. Rosenbusch's laboratory in Heidelberg, Lewis pronounced the rock to be a true eruptive lava—a porphyritic

volcanic peridotite of basaltic structure, or, according to Rosenbusch's nomenclature, the palæo-volcanic representative of a biotite-bronzite-dunite, being an olivine-bronzite-picrite rich in biotite." To this rock he gave the name of kimberlite, distinguishing between *kimberlite proper*, a typical porphyritic lava; *kimberlite breccia*, the same lava broken and crushed by volcanic movements within the pipe, and crowded with included fragments of foreign rock; and *kimberlite tuff*, the fragmental and tuffaceous portion of the same volcanic rock, all these varieties passing into one another and occurring together in the same neck or crater. The kimberlite breccia constitutes, according to Carvill Lewis, the greater portion of the pipe material, but it is traversed by dykes of kimberlite proper, and contains streaks and patches of a soft, "soapy" material which appears to be kimberlite tuff. As to the diamond, it is as much a constituent of kimberlite as the more commonly occurring biotite, garnet, titanite and chromic iron and perovskite, and consequently must have been produced *in situ*.

From this view Bonney was led to dissent by a microscopic examination, made in 1899, of specimens from the Newlands mines in West Griqualand ("The Parent Rock of the Diamond in South Africa," Proc. Roy. Soc., vol. lxx., 1899, p. 620). Among these specimens was a rounded boulder of a rock which was described by him as a "holocrystalline mixture of chrome-diopside and garnet, with a few small enclosures of olivine, in other words, a variety of eclogite and of igneous origin." The interest of the specimen lay in the fact that it contained diamonds, and from this Bonney drew the momentous conclusion that the birth-place of the diamond and of the garnet, pyroxenes, olivine, &c., was not the "blue ground" itself, but the eclogite which occurred in the latter as foreign boulders. He further concluded, from the smooth exterior of the specimen examined, that the boulders were water-worn, and were derived from a conglomerate bed "at the base of the sedimentary series in proximity to a crystalline floor." The blue ground then, according to Bonney, is a true breccia produced by the destruction of both crystalline and sedimentary rocks, the "result of shattering explosions followed by sulfatiferous action."

R. Beek (*Zeits. für prakt. Geol.*, 1879, p. 417), to whom similar specimens from the Newlands mines had been sent, differed from Bonney as to the origin of the so-called boulders of eclogite, which he considered to be concretions formed at great depth in the kimberlite magma—like the well-known olivine nodules in the basalt of Finkenbergr, near Bonn, described by Rosenbusch and others as early segregations from the basalt magma. The serpentine breccia which represents the present condition of the kimberlite magma contains all the constituents of the nodules. The rounding of the boulders is to be ascribed to attrition during the upward course of the pyroclastic material in the pipe. Beek agreed with Bonney that the diamonds were formed at great depth, but for a different reason, namely, that only at great depths could such coarse-grained granular segregations from the magma have been produced. In a more recent paper (*Zeits. der deutsch. geol. Gesellsch.*, 1907, p. 226), Beek gives results of a further examination of the Newlands eclogite, which, by the way, he proposes to call "Griquaite." In addition to the constituents already named, he finds biotite, perovskite, zircon, rutile, and graphite. He repeats his conclusion that the "boulders" are deep-seated (intra-telluric) segregations from the same magma from which the pipe material is derived, and ascribes the genesis of the

diamond to the presence in the original magma of metallic carbides, it being his opinion that not only the diamonds contained in the eclogite, but also the isolated individuals in the blue ground, must have been formed at great depth.

The views of the earlier writers can be grouped into two distinct theories:—(1) The pipe material is a breccia or tuff produced with its contained diamonds, by violent volcanic agencies, from pre-existing rocks (Cohen, Chaper, Bonney, Beck). (2) It is a true eruptive lava which has solidified *in situ*, the diamonds having been separated out during this consolidation (Dunn, Maskelyne, Flight, Carvill Lewis).

Among the recent writers on the subject, H. S. Harger and G. S. Corstorphine support the view that the diamonds have been derived from a deep-seated source, the former mentioning that out of a parcel of 372 stones examined by him, 119 were found to be broken fragments of original crystals. F. W. Voit, on the other hand, regards the "splints" as either imperfectly formed crystals or as having been broken during the processes of mining and washing. (He would find it difficult, however, to explain the fractured character of the Cullinan diamond¹ by either of these hypotheses.) Voit regards the pipes as embryonic volcanoes. According to him, the igneous magma which rose in the pipes, being unable to reach the surface, was forced to solidify under the pressure of the superincumbent strata in circular or elongated moulds, thus giving rise to what he terms "conical batholiths." While the extruding magma was still in the semi-plastic state, it was agitated by further gaseous eruptions, to the action of which the brecciated character of the blue ground is largely to be ascribed. He regards the eclogite "boulders" as concretions of the kimberlite magma, formed *in situ*. He admits, however, the presence in the blue ground of boulders of granite, gneiss and crystalline schists of exotic origin.

A. L. du Toit, of the Cape Geological Commission, who during 1906 was working in the Kimberley district, has formulated a theory which combines parts of both the earlier views, and is more in accord with modern ideas of petrogenesis. According to him, kimberlite is a hybrid rock derived from a deep-seated magma (having the composition of a limburgite) which incorporated the shattered fragments of the various holocrystalline basic and ultra-basic components of the floor through which it broke. During its further ascent the eruptive mass caught up and included in its body fragments of the sedimentary beds through which it passed. A portion of its brecciated character, however, is to be attributed to movements during consolidation. Of the minerals found in the blue ground, du Toit considers the tremolite, smaragdite, epidote, orthite, tourmaline, muscovite, biotite, apatite and zircon to be xenocrysts derived from deep-seated rocks of acid composition (granite, gneiss, pegmatite, &c.); while he regards the olivine, pyroxenes, garnet, ilmenite, magnetite, chromite, spinel, sphene, kyanite, and the diamond as xenocrysts derived from basic and ultra-basic holocrystalline rocks. In addition, the original eruptive magma gave rise on consolidation to authigenic crystals of olivine, diopside, brown mica, magnetite, ilmenite, chromite, apatite, perovskite, nepheline and mellite.

In support of his view, du Toit gives instances of strong contact metamorphism effected by the pipe material during its intrusion. Few cases of contact-metamorphism, however, have hitherto been observed. Corstorphine (*loc. cit.*, p. 65), for instance,

¹ Vide F. H. Hatch and G. S. Corstorphine, "A Description of the Big Diamond recently found in the Premier Mine, Transvaal (*Geol. Mag.*, p. 179, 1905).

states that the fragments of sandstone, shale, &c., that he has found enclosed in the blue ground are conspicuously unaltered.

Much of the recent controversy has centred round the relation of the kimberlite dykes to the pipes. The fact that material of practically identical character to the pipe rock, and similarly brecciated, occurs in the form of dykes has long been known; but the latter have hitherto attracted but little attention, owing to the fact that the dyke material either carries no diamonds or so few as to be unworkable at a profit.

There can be no doubt that the dykes are genetically connected with the pipes, but were they formed contemporaneously, or did the dykes precede the pipes or *vice versa*? Dr. Voit states that the pipes are younger than the dykes, which in all cases terminate, according to him, at the pipe-walls. Besides, fragments of dyke rock occur in the pipes, but pipe rock is never found in the dykes. Although chemically identical magmas, there are slight mineralogical distinctions, due, probably, to the different rate of cooling, which enable the rocks to be easily identified. Du Toit advocates the contrary view, namely, that the pipes and fissures have been formed contemporaneously. Between the extremes of occurrence in pipes or dykes he traces every gradation, and mentions "fissure-swelling," which, though dyke-like, expand at one or more points. Almost every pipe will be found to have one or more dyke-like offshoots, if not at the surface, at some greater depth. In the Newlands group, the pipes are connected below ground by a narrow dyke of kimberlite; on Secretaris, west of Kimberley, there are fissures with one or more little swellings on them, and there are numerous dykes and veins varying in width from mere stringers to belts of many feet. The strike of the fissures corresponds in some instances to that of the enclosing rocks (Newlands, Smith, and Peiser mines), indicating that the intrusion followed planes of physical weakness.

Instances might be multiplied to show the differences of opinion that obtain among South African geologists with regard to these interesting occurrences. They only emphasise the difficulties of the problems awaiting solution.

One word as to the date of intrusion. The pipes and fissures are later than the Karoo dolerites, which, in their turn, cut the Stormberg lavas. They are therefore at least of post-Rhætic age. If the melilite-basalt pipes of Sutherland are connected in origin with an intrusion of melilite-basalt in the Uitenhage beds at Spiegel River (Heidelberg, Cape Colony), then the occurrences of kimberlite are of post-Neocomian age (*vide* Rogers and du Toit, *loc. cit.*).

F. H. HATCH.

THE INDUCTION OF ANÆSTHESIA BY CHLOROFORM.

THE inquiry which was initiated seven years ago by the Council of the British Medical Association into the many-sided problem of chloroform-anæsthesia has added greatly to our knowledge, and directed particular attention to the fact that the administration of an amount of chloroform vapour above 2 per cent. in the inspired air is fraught with danger to the patient. The scope of this inquiry has been further supplemented and extended by independent researches carried out in this country and in France.

The view has been held, and to some extent verified by experiments, that during the progress of anæsthesia the drug was absorbed by the corpuscles rather than by the plasma of blood. The experiments of Benjamin Moore and H. E. Roaf first definitely proved that *in vitro*, with an adequate concentration or

solution tension of chloroform in the blood; easily dissociable compounds or aggregations were formed between the drug and the proteins, including hæmoglobin, of the blood. It was a natural inference from these experiments that the production of anæsthesia, either in isolated cells or in unicellular or multicellular organisms, was due to the formation of such compounds between cell-protoplasm and chloroform. With a very small constant quantity of chloroform, 1 per 100,000, in blood it has been found that the anæsthetic effect is in no sense a cumulative one; the degree to which a living tissue is affected depends entirely upon the concentration of the chloroform in the blood, and therefore in the living cell, for the degree of anæsthesia remains constant, and persists for only so long as a definite solution pressure is maintained. Any given grade of anæsthesia is therefore entirely independent of the total amount of chloroform which is supplied at an adequate concentration. In the induction of anæsthesia in man the various stages from slight to profound must therefore essentially depend upon the gradually rising pressure of chloroform in the blood. When the amount of chloroform in inspired air is very low, the induction of anæsthesia is impossible; while that too high a percentage is lethal, the unfortunate accidents which occur from time to time bear abundant witness.

The rate of absorption of chloroform during the induction of anæsthesia has been studied by many observers, most of whom have attempted a solution of this problem by ascertaining the degree to which the lungs are ventilated during narcosis, and the extent to which chloroform is apparently retained by the body. This is determined by estimating the difference between the chloroform-content of inspired and expired air. In the case of inspired air this can easily be done with accuracy, but, especially with a low percentage of chloroform, the corrections which are necessary for temperature, amount of carbon-dioxide and aqueous vapour are so great as to render an accurate determination of the amount of chloroform in expired air a matter of much difficulty.

The rate at which chloroform is taken up by the blood can, however, be directly measured. In three papers just published in the Proceedings of the Royal Society, Dr. G. A. Buckmaster and Mr. J. A. Gardner have described the exact procedure of their experiments, which were undertaken with the view of ascertaining the function of the red corpuscles in anæsthesia produced by chloroform. Two of the papers fully describe experimental studies on "The rate of the assumption of chloroform by the blood during anæsthesia," and "The rate of elimination of chloroform from the blood after anæsthesia."

Hitherto an exact determination of chloroform in blood has been found to be difficult. It is not possible to use Neumann's method for chlorides. French observers, Tissot, Mansion, and Nicloux, have employed a method which is based on Dumas's reaction, which, as carried out by Nicloux, is rapid, convenient, and capable of giving satisfactory results, though it does not possess such a high degree of precision as an exact chemical method as does the one which was introduced by Carius for the determination of chlorine in organic compounds. This method was first used by Buckmaster and Gardner in their experiments on the anæsthetic and lethal quantity of chloroform in blood. The maximum error of this method never exceeds five per cent., and is generally much less. The amount of chloroform in the blood at any stage of anæsthesia is calculated from the difference between the chlorine-content of the blood of each individual animal before and after the induction of anæsthesia.

Buckmaster and Gardner had shown that when a mixture of chloroform and air is inhaled, almost all the drug is held by the red corpuscles; in one case no less than 98.5 per cent. of the total chlorine in the blood was found associated with the red corpuscles after 2 per cent. of chloroform vapour had been inhaled for three-quarters of an hour. It would appear, therefore, highly probable that in chloroform narcosis the transport of chloroform from and to the lungs is a function of the red corpuscles, which are the chief vehicle for the drug. If this is the case, it is obvious that although the absolute quantity of chloroform in the blood of any individual would vary with the mass of blood, the percentage amount in a sample of blood would not vary, other conditions being constant, whether the total amount of blood in the body was augmented or diminished. A large number of experiments were therefore performed, in order to elucidate this point. The general aim of these was to vary the mass of blood either by bleeding or by introducing the greater part of the blood of one animal into another of the same species. The blood was directly transfused. In experiments where the asphyxial state was reached rapidly, the average percentage of chloroform in the blood was found to be practically identical before (0.043 gram) and after bleeding (0.045 gram). In cases where the asphyxial state occurred half an hour to an hour and a half after the commencement of chloroform-inhalation, the figures were 0.048 before and 0.051 after bleeding. The paper gives full details of fourteen experiments which have been made as to the percentage amounts of chloroform in blood before and after hæmorrhage, and these, together with other experiments in which comparisons were made with a normal, with an augmented, and with a diminished mass of blood in the same animal, show conclusively that the percentage of chloroform in the blood does not vary with differences in the mass of the circulating blood. The results of the experiments are therefore in complete accord with what would be the case if, as Buckmaster and Gardner suspected, the red corpuscles were the essential agents for the transport of chloroform.

The curves which illustrate the chloroform-content of the blood during the induction of anaesthesia with 2 per cent. or 3 per cent. of inhaled chloroform vapour are of much interest. At the present time these curves, constructed from data fully given in tabular form, possess great interest. Not only are they the only curves which exist that show clearly the rate at which the percentage of chloroform rises in the blood from the commencement of the administration of the anaesthetic, but the fact which is so well known, that deaths during anaesthesia not infrequently occur within two or three minutes after the patient commences to inhale, is easily understood, for the chloroform-content of the blood mounts up so rapidly at first as to constitute a veritable danger-point. The amount or tension of the drug in the blood rises in the initial stage of anaesthesia with great rapidity to a value which approaches a maximum. If the individual passes this stage naturally, then after a distinct fall in the chloroform-content of the blood, the amount of the drug quickly rises again towards a maximum value, and an equilibrium between the factors which determine the amount of chloroform in the blood is subsequently obtained, the processes of intake and output at the surface of the lung going on side by side. This period corresponds to the second stage of anaesthesia. It may last for one or more hours, and represents the state of surgical anaesthesia. But the condition of the individual is far from one of safety, for although

this stage can be maintained with an amount of chloroform in the inspired air which could not have induced anaesthesia, throughout the whole of this time the difference between the amount of chloroform which is present in the blood and what is found at the lethal point is very minute. The authors have laid special stress on this point, and from a careful examination of their curves it would appear that their contention is a sound one.

In their third paper Buckmaster and Gardner have studied the rate of elimination of chloroform after anaesthesia. Five typical experiments, accompanied with full data and curves, are given. During recovery from chloroform small quantities of blood were in some cases taken at intervals from an artery; in other cases the blood was taken by a long canula from the venous system close to the right auricle of the heart, and one curve is constructed from data obtained by analysis of samples, taken simultaneously, of arterial and venous blood from the carotid artery and the neighbourhood of the right auricle. The authors find that the rate at which chloroform is eliminated at the surface of the lungs is at first comparatively rapid, though subsequently this becomes much slower. But the initial rates of elimination are much less rapid than the initial rates for absorption, and therefore, on the whole, elimination of the drug is a much slower process than the assumption. From Tissot's observations it would appear that during recovery from chloroform anaesthesia the amount of the drug in venous blood constantly exceeds the amount in arterial, and he suggests that a study of the chloroform-content of arterial blood should be made during the induction of anaesthesia, and of venous blood during the disappearance of this state. Buckmaster and Gardner do not confirm all the results obtained by Tissot, though they are in entire agreement with him on the important fact that at the moment when the inhalation of chloroform is stopped, arterial blood always contains an excess of the drug when compared with the amount in venous blood.

The salient points of these researches have now been indicated. The application of an exact method, and the performance of a large number of experiments which were carried out under precisely similar conditions in the physiological laboratory of the University of London, have enabled Dr. Buckmaster and Mr. J. A. Gardner to complete this portion of their work, and their results will probably afford a sure basis on which a full knowledge of the physiology of the anaesthetic process during the inhalation of chloroform may in the future be built up.

ARCHÆOLOGICAL REMAINS IN WALES AND THE MARCHES.

IN the sphere of archaeology the University of Liverpool bids fair to surpass all other British homes of learning, ancient or modern. Backed by a number of wealthy citizens, more cultivated than the corresponding class in any other town of the Empire, it has lent generous aid to the excavator, and is able to boast, at the present time, of a vigorous archaeological school directed by men whose names are pledges of efficiency in their several departments. So far, however, it has interested itself mainly in the elucidation of classical history, in the study of Greek art, and in exploration in Asia Minor and Egypt. Now for the first time its attention is being directed to regions nearer home; at the instance of many Celtic scholars, and numbers of influential Welshmen both in the city and the Principality, it is undertaking the supervision of no less a work than the survey and

systematic excavation of historic remains in Wales and the Marches. As a result of the meeting convened by the Lord Mayor of Liverpool (Dr. R. Caton)—an event already chronicled in these columns—a fund has been started and committees appointed—general, advisory, and financial—for the furthering of the scheme. The actual operations, needless to say, will be watched by the heads of the archaeological school, Profs. Bosanquet, Garstang, Myres, and Newberry. Assistance has also been promised by Prof. Haverfield, of Oxford. The work will be carried out in cooperation with the University of Wales, with the Cambrian Archaeological Association, with the district or county societies, and with such local committees as it may be found advisable to form from time to time. All these bodies are to be represented on the general committee, which is to include the names, not only of well-known scholars, such as Prof. Haverfield, Sir John Rhys, and Dr. Arthur J. Evans, but of patriotic Welshmen representing every interest and every shade of opinion.

The magnitude of the undertaking and its importance for the study of Welsh ethnology and history can hardly be exaggerated. Owing, it is suggested, to the absence of a capital where their records could be brought together and examined, the Welsh have unduly neglected the investigation of their past, so that the questions which beset the historian are unusually numerous and difficult. It has been the fashion hitherto to search for their solution in the national literature, the memoirs, so to speak, of the people themselves, taking them, in fact, at their own valuation. It cannot be denied that this method has its advantages, the facts which it supplies, when they can be shown to be facts indeed, stamping themselves on the mind with peculiar vividness. In this case, however, they have only too often ended as they began, mere autobiography, with little or no objective value, good material for history, it may be, but still not history. It can no longer be doubted that the study of the Welsh texts, if it is not to end in mere guess-work, must be supplemented for the early period, at any rate, by the study of evidence of another kind, the evidence, that is to say, of historic sites and monuments. That such is to be obtained has been shown by the sporadic excavations of recent years, but until last November it seemed useless to hope for a systematic archaeological inquiry; now at last, under the direction of men who will not suffer a penny or the stroke of a pick to be spent in vain, the secrets of cromlech, camp and battlefield will be brought to light, and the story of the past reconstructed step by step.

There are several directions in which research seems particularly needed. It is important in the first place, through the exploring of Roman sites, to determine the relation of the mountaineers to the Roman army in possession, a subject which so far has remained shrouded in mystery. How excavation can help to increase our knowledge of the later Roman Empire may be seen from the work carried out in Germany and Austria, in North Africa and Asia Minor, where the Roman frontier defences have in each case been marked out and made available for comparison, or, looking nearer home, from the operations of the Society of Scottish Antiquaries and other learned bodies, during the past ten years, in Scotland. Though only nine or ten of the Scottish forts have been investigated, definite conclusions have already been formed. The scanty statements of civilians writing at a distance, which used to be our sole authorities for Roman Scotland, it has now been found possible to verify and amplify by means of the handiwork and personal belongings of the frontier guards themselves.

At the present time there are ten Roman sites, most of them military posts, awaiting excavation in Wales and the Marches, and there is no reason to doubt that it will be as fruitful in their case as in any of those we have mentioned. We shall be disappointed indeed if it does not enable us to judge of the length of the Roman occupation of Wales, of their frontier policy, and the character and methods of their government. We need hardly point out that light shed on these subjects will be light, not only on the Silures, but on Roman Britain as a whole.

From the Roman remains the committee may proceed with advantage to the examination of the sites and monuments of early Christianity in Wales. Here also valuable data may be had for comparison from other countries, much having been done, both in Ireland and France, to preserve and record the memorials of the primitive church. Among Welsh ecclesiastical sites Bangor is *y Coed* in Flintshire, and Whitland (*Ty Gwyn Ar Dav*) in Carmarthenshire seem to promise the richest results. Again, the monasteries of Norman times might be explored with a view to the production of a Welsh Monasticism, the place and personal names in the charters to be corrected with such accuracy as to make these a help, not, as now, a stumbling-block to the student.

Other subjects for investigation will suggest themselves without doubt to all those interested in the early history of this island. The reader will have noticed that the researches specified above are mainly in the nature of digging out or clearing of the ground. We need scarcely remind him that valuable evidence may also be obtained through the observation of things on its surface. The materials for the early history of Wales, like that of other countries, must be sought with the theodolite no less than with the pick or shovel. That it will help us to fuller knowledge of the pre-Celtic inhabitants of the country has been made clear by Sir Norman Lockyer during his expeditions to South Wales. He has indicated the lines to be followed in this kind of inquiry, and the committee cannot do better than follow in his steps. It is occupied as yet with preliminary arrangements. Among the subjects which may be expected to engage its attention in the first instance are the following:—

(a) The preparation of an archaeological map of Wales and the Marches, on which all known sites and individual finds shall be marked, together with a bibliography and index of all known information regarding them.

(b) The execution of an archaeological survey of the whole area, to supplement the recorded material, and complete the archaeological map, so far as surface evidence is required.

(c) The consideration of a scheme of successive excavations for the sites, which may be selected as of most crucial importance, for the solution of the questions of distribution and historical sequence, certain to be raised by the preliminary survey and mapping.

We will only remark, in conclusion, that great schemes cost money, and that those which we have been discussing are not likely to disprove the rule. The expense of surveying a county has been estimated at 150*l.*, that of excavating each of the Roman forts, together with the exploration of the adjacent roads and the subsequent publication of results, at not less than 100*l.* Liverpool is proverbially generous, but even so there will be ample room for the liberality of sympathisers outside, both Welshmen and others. We sincerely hope that the appeal of the committee will not be made in vain; it would be regrettable indeed if its work were retarded or hampered through lack of the necessary funds.

We are given to understand that an illustrated

report of the work will be presented every year to subscribers of *2l. 2s.* and upwards, and for five years to all donors of *10l. 10s.* Cheques should be sent to the treasurer, Mr. T. Rowland Hughes (North and South Wales Bank, Liverpool), and requests for information addressed to the organising secretary, Captain A. O. Vaughan (38 Bedford Street, North Liverpool).

DR. P. J. C. JANSSEN.

FRANCE is again called upon to mourn the loss of a veteran astronomer whose services have rendered him conspicuous among the many eminent men of science his country has given to the world. Jules Janssen, born in 1824, was first a painter, but for more than fifty years contributed to the scientific literature of his country and enriched many departments of physics by his untiring energy, his accurate observations, and his fertility of resource. He was a great traveller; his first scientific expedition was in 1857 to Peru, to study the magnetic equator. Ten years after he was studying the eruption of Santorin with Fouqué. It is not possible to do justice to his work within a small compass, but fortunately its salient features will long remain fresh in our memories.

Janssen's reputation will rest mainly upon his numerous and important researches on light spectra, and the methods he employed for pursuing his investigations. He early recognised the power of the spectroscopy as an engine for research, and in its application to many problems connected with solar activity he was without rival among his own countrymen. In 1862, he published the first results of his celebrated researches on the origin of the telluric lines in the solar spectrum, and it is only necessary to recall the history of spectroscopy in the last half-century to make us appreciate the value of his pioneering services in this direction. The perseverance and ardour with which he pursued this subject was shown, first at La Villette, where he so arranged his experiments that the light the spectrum of which was to be examined passed through a tube, 37 metres long, containing steam under a pressure of seven atmospheres, and later, at Geneva, where in another series of experiments the light traversed several miles of atmosphere immediately overlying the lake. For many years the same problem in different aspects occupied his attention.

Long after the part played by water vapour in modifying the spectrum had been settled, Dr. Janssen had recourse to experiments of the same nature in order to decide the precise character of the spectrum effects due to oxygen. The pursuit of this question and his anxiety to vary as much as possible the conditions under which his observations were made, carried him to the top of Mont Blanc, where his experiments warranted him in asserting that there was no evidence of the presence of oxygen in the exterior and cooler parts of the solar atmosphere. To speak with equal confidence of the lower, and, consequently, hotter layers, it was necessary to examine the spectrum of oxygen when submitted to high temperatures and great pressure. By ingenious devices, Dr. Janssen succeeded in raising oxygen to a temperature of 800° or 900°, and in placing the gas under a pressure of 1000 atmospheres. As before, his observations pointed to the absence of oxygen in the sun's atmosphere. His researches on the effect of planetary atmospheres in modifying the spectrum of solar light were equally thorough and satisfactory.

The observations made on Mont Blanc firmly convinced Dr. Janssen of the advantages offered by high mountains for the conduct of certain inquiries, in

which it was of importance to reduce as far as possible the thickness of the atmosphere, through which observations had to be made. In spite of increasing age and the inconvenience of lameness, he interested himself energetically in the construction of the Mont Blanc Observatory, and on more than one occasion personally made the ascent of the mountain to assure himself of the success of the enterprise. Under his auspices various physical inquiries have been successfully pursued in this elevated observatory.

As an observer of the sun at the time of total solar eclipse, Dr. Janssen was indefatigable. In 1868, he began that long series of observations which have so much enriched our knowledge of the sun's surroundings. For it was while observing this eclipse at Guntort that he was impressed with the possibility of observing the prominence lines on the limb of an un-eclipsed sun. How, without delay, he put his plan into operation and enjoyed the advantage of a prolonged eclipse is well known, as also the fact that the announcement of his discovery reached the Paris Academy of Sciences at the same time as a similar contribution from Mr. (afterwards Sir Norman) Lockyer informed that body of the successful results of his more prolonged researches. The claims of each have been fully admitted, and just as the names of Adams and Le Verrier are connected with a famous problem in gravitational astronomy, so those of Lockyer and Janssen are joined in the solution of a fundamental problem of physical astronomy. A medal containing effigies of the heads of the two astronomers side by side was struck by the French Government to commemorate this "Janssen-Lockyer Discovery." This is an oft-tale tale, and it would not be necessary to repeat it here but for one circumstance which is not so well known, and which it is desirable to emphasise. This is the generous recognition which Dr. Janssen ever expressed towards his English *confrère*, and his ready acknowledgment of the value of English work. Fortunately, the days of international jealousy in science have passed, but the loyal and hearty appreciation which Dr. Janssen exhibited stands out as a conspicuous example of unselfish and kindly interest, in which no unworthy considerations found a place. Needless to say that his warm-hearted sympathy and encouragement was highly valued and cordially reciprocated.

At Sir Norman Lockyer's suggestion, Janssen was invited to join the English Eclipse Expedition of 1870, and as he was then in besieged Paris, thanks to the exertions of the English Foreign Office the invitation reached him there by the hands of Bismarck, who accompanied it with a safe conduct. This he declined, and left the beleaguered city in a balloon. On that occasion he carried with him the essential parts of a reflector especially constructed to collect evidence about the solar corona. He repaired to Oran, and deserved better fortune than to find the sky completely obscured by clouds at the time of the eclipse. In 1871 and 1875 he was again in Asia, taking part in the observation of solar eclipses, while in 1883 he was one of that remarkable party of enthusiasts who repaired to the lonely coral reef in the Pacific known as Caroline Island. For this eclipse Dr. Janssen used telescopes of six and eight inches aperture, and on his photographs obtained an extension of the corona further than it could be traced in the field of the telescope, revealing a remarkable complexity of structure. Here, too, he confirmed his previous suspicions of the presence of reflected Fraunhofer lines in the spectrum of the corona. His passionate interest in solar phenomena never deserted him, and on the occasion of the eclipse in 1905, notwithstanding his advanced age, he was

found among the observers stationed on the line of totality as it crossed the Spanish peninsula. At a still later period, when the International Union for Cooperation in Solar Research met at Meudon, last May, Dr. Janssen, as president of the congress, exhibited an unflinching interest in all that could promote the object of the meeting.

On the occasion of the transit of Venus in 1874, Janssen not only took part in the observations—going for this purpose to Japan—but devised an apparatus to take a number of pictures of the sun in a short space of time. In many ways the late astronomer distinguished himself by his photographic researches. Not only was he one of the first to direct his attention to the possibility of photographing comets and nebulae, securing satisfactory pictures of Tebbutt's comet of 1881 and of the Orion Nebula, but his photographs of the solar surface, taken at the Meudon Observatory, have acquired a world-wide renown, both for the beauty of the results obtained, and the ingenuity of the devices employed to secure short and uniform exposures. These photographs were not left as mere pictures to please the eye by the infinite variety they revealed. They were studied and compared until the photospheric network of varied granulation was made to disclose its tale, and put us in possession of the beginning of a solar meteorology. In the course of his photographic experiments he was led to suggest the use of a camera with double slits, so as to allow only a narrow portion of the spectrum to reach the photographic plate, a method of observation which in the hands of Prof. Hale and Deslandres has proved so effective.

He served his country in many capacities, but perhaps rendered no service greater than that of establishing and organising the observatory at Meudon. By this act a permanent home for the furtherance of physical astronomy and solar research has been ensured, and here the work which he began and pursued with such eagerness will be carried on with more powerful instruments than were "at his command"; but however successful its future career may prove, it will owe its origin in no small measure to the insistence, perseverance, and reputation of Dr. Janssen.

In many ways his colleagues acknowledged the value and extent of his services. He was Commander of the Legion of Honour, Membre de l'Institut; he was the oldest member of the Academy of Sciences, having succeeded Langier in 1873. He was also a member of the Bureau des Longitudes, and had been decorated with the Lalande medal. The learned societies of many countries enrolled his name on their list of fellows. In this country he was a foreign member of the Royal Society, from which he received the Rumford medal for his researches; Edinburgh made him an LL.D. of that university, and in 1872 he was elected an Associate of the Royal Astronomical Society.

NOTES.

The annual meeting of the British Science Guild will be held at the Mansion House at 4.15 p.m. on Wednesday next, January 15, by invitation of the Lord Mayor. Mr. Haldane, president of the Guild, will address the meeting; and among other speakers will be Dr. T. H. Warren (Vice-Chancellor of the University of Oxford), Sir Archibald Geikie, K.C.B. (secretary of the Royal Society), Sir John Rhys, Sir Wm. Bousfield, Sir John Wolfe-Barry, K.C.B., F.R.S., and Mr. A. Siemens.

The death is announced of Prof. Albert Lévy, professor of mathematics at the Paris Municipal School of Industrial

Physics and Chemistry, and director of the chemical department of the Municipal Observatory of Montsouris. Prof. Lévy was well known for his analyses of the air and water supply of Paris.

A TELEGRAM from BROWNSTOWN, Jamaica, announces that a severe earthquake occurred at 8.5 a.m. on January 3. Considerable damage is reported from Kingston and other places on the south shore.—Reuter reports on January 4 that Vesuvius is again active. The volcano is emitting clouds of vapour from large fissures near the summit of the crater, and also towards Atrio Cavallo.

A REUTER message from Rome states that Signor Rava, Minister of Public Instruction, has appointed a special commission to direct and supervise the excavations at Herculaneum, composed of Commendatore Gattini, administrative director of the Museum of Naples; Signor De Petra, professor of archaeology of the University of Naples; Prof. Gabrici and Prof. Dall'Osso, both of the Naples Museum; Prof. Sogliano, director of the excavations at Pompeii; Commendatore Avena, director of the technical office of the monuments of Naples; and two civil engineers of the province of Naples.

ON Tuesday next, January 14, Dr. A. A. Gray will deliver the first of two lectures at the Royal Institution on the internal ear of different animals, and on Thursday, January 16, Prof. W. W. Watts will deliver the first of two lectures on (1) the building of Britain. On Saturday, January 18, Prof. Gisbert Kapp will commence a course of two lectures on the electrification of railways. The Friday evening discourse on January 17 will be delivered by Prof. T. E. Thorpe, on the centenary of Davy's discovery of the metals of the alkalis, and on January 24 by Colonel David Bruce, on the extinction of Malta fever.

THE discovery of a large group of dene-holes in the woods between Woolwich and Erith, close to the ruins of Lessness Abbey, was announced in the *Times* of January 3. Two of these holes have already been explored, the position having been marked in each case by a shallow cup-like depression on the surface overgrown with verdure. Excavation in the centre of the hollow exposed the shaft, which is rather more than 3 feet in diameter, and circular in transverse section. After descending for about 50 feet through loam, the shaft enters chalk, and having penetrated this for 4 feet or 5 feet expands into chambers about 18 feet in height. In the sides of the shafts are holes, evidently for supporting a rude kind of ladder for descent. A conical mound of earth, about 10 feet high, occupies the floor at the bottom of the shaft. Each cave has six chambers grouped radially around the central shaft, so as to form in plan a rough double trefoil, recalling the pattern familiar to explorers of dene-holes elsewhere.

ACCORDING to a paper by Mr. H. Beeston published in the December (1907) number of the *Zoologist*, the breeding-range of the marsh-warbler in the south of England is gradually spreading east, a nest having been observed during the past summer in Hampshire. The nest was attached to four or five reeds at an elevation of about 4 feet, like that of a reed-warbler.

To *Nature* for November and December, 1907, Prof. A. W. Brögger contributes an illustrated article on "ooliths," in which a number of types from various parts of Europe are described and figured. The author appears to be convinced that these stones were shaped by human agency for special purposes, describing some as knives, others as scrapers, &c.

AMONG the articles in *Schriften naturfor. Ges.*, Danzig, vol. xii., part i., attention may be directed to one by Dr. A. Wallenberg on the anatomy and physiology of the central nervous system of man. The paper, of which only the first portion is now published, is based on an address delivered before the society so long ago as 1888, and has been presented to the public by request. It deals specially with modern methods of brain-research and their result, and is illustrated by several diagrams, coloured or otherwise, displaying in a remarkably clear manner the complicated system of "telegraphy" by which coordinated movements of the body are brought about.

IN his presidential address to the Indiana Academy of Science, as reported in the Proceedings of that body for 1906, Dr. Robert Hessler states that both malaria and tuberculosis seem to have made their appearance in the country since its colonisation by the white man. The advent of malaria is attributed to the felling of the forests, and the consequent periodical drying-up of the smaller rivers, and the destruction of fish; accompanied by an enormous increase in the numbers of mosquitoes. This disease rapidly attained its maximum, but, under preventive measures, as speedily declined, and has now been eliminated from large cities, and to a great extent from their suburbs. Tuberculosis, on the other hand, which is essentially a disease of civilisation, has been steadily on the increase ever since its introduction, and shows no signs of having yet attained its maximum.

THE report on agriculture in the Virgin Islands for 1906-7 refers mainly to the work done at the experiment station at Tortola under Mr. C. W. Fishlock. Although formerly cotton provided a valuable crop, the cultivation had to be re-introduced by the Imperial Department of Agriculture in 1903; since that time the industry has advanced, and is now remunerative; about one-third of the quantity grown is Sea Island cotton. It has also been demonstrated that many parts of the island are suitable for cacao cultivation. A series of illustrations of the experiment station add to the interest of the report.

IN the *Geological Magazine* (June and November, 1907) Prof. A. C. Seward publishes descriptions of fossil plants from Egypt and South Africa. Of three Egyptian specimens, only one, a new species of *Clathropteris*, is sufficiently well preserved to be named; it furnishes some evidence that the beds from which it was collected were of Rhaetic or Lower Jurassic age. The material from South Africa yielded a *Phyllothea* and an *Osmundites*, both made types of new species, a *Lepidodendron* impression, and a *Bucklandia* stem. The *Osmundites* stem and the *Lepidodendron* both show interesting morphological features, while the *Bucklandia* is the first record of a Cycadean stem from plant beds of the Uitenhage series.

OWING to the character of the leaves and the intervals that elapse between the flowering periods, the classification of the genus *Agave* is a difficult matter; also the existing nomenclature is so uncertain that it becomes necessary to study the species in their native habitats. Two papers on *Agave* and the allied genus *Furcraea* are published in the eighteenth annual report of the Missouri Botanical Garden. In the former, Prof. W. Trelease discusses the three species *macroacantha*, *pugioniformis*, and *Karwinskii*, belonging to the group of *Euagaves*. The second species is merged in *macroacantha*, for which the author gives a diagnosis and illustrations showing the plant in its natural environment. Similarly the species

Karwinskii, that produces a trunk about 10 feet high closely set with leaves, is described. The article on *Furcraea*, contributed by Mr. J. R. Drummond, furnishes an epitome of the literature of the genus, with a synopsis of known species.

IN connection with the bicentenary of the birth of Euler, the great Swiss mathematician, *Engineering* of December 27, 1907, gives an account of his life, work, and character.

WITH the object of helping prospectors, the Geological Survey of Western Australia has compiled a Bulletin (No. 30) giving particulars of the distribution and occurrence of the ores of metals other than gold. The Bulletin, which covers 129 pages, has been written by Mr. E. S. Simpson and Mr. C. G. Gibson, and contains details of the occurrence in Western Australia of ores of copper, tin, lead, zinc, antimony, bismuth, iron, nickel, cobalt, manganese, aluminium, tantalum, tungsten, and molybdenum.

IN the *Engineering Magazine* (vol. xxxiv., No. 3) Dr. A. Gradenwitz gives an illustrated description of the Royal Bavarian Workmen's Museum at Munich. It is one of the most important museums devoted to industrial hygiene in Germany, where the cause of industrial betterment has been largely furthered by such institutions. The museum is intended to further any efforts made in the field of workmen's protection, while affording a comprehensive view of present achievements in the prevention of accidents, in industrial hygiene, sanitary habitation, and alimentation.

AT a meeting of the Association of Water Engineers on December 14, 1907, an interesting paper was presented by Mr. W. R. Baldwin-Wiseman on the influence of the thickness of the pipe wall on the rate of discharge of water from minute orifices piercing the pipe. The results of the experiments described show that, although the diameters of the orifice may vary considerably, yet for a similar ratio of the thickness of the wall to the diameter of the orifice, the coefficients of discharge are approximately the same at the pressures recorded of 60 lb., 40 lb., and 20 lb. per square inch, and that the coefficients of discharge are in general higher for large values of the ratio of thickness to diameter than for small values of that ratio.

AN elaborate memoir of considerable economic interest, by Mr. Mauric Alfassa, is published in the *Bulletin de la Société d'Encouragement* (vol. cix., No. 9). It deals with the reduction of the working day to eight hours, and records the experience of the French Government establishments and of works in other countries. The author considers that the eight hours' day is practically realisable in all cases. In the cases where the reduction has not been made, it is possible, as is shown by English experience, particularly at the works of Messrs. Mather and Platt, sensibly to abridge the working hours, maintaining at the same time the production and the cost of production, the increase in certain departments being compensated by savings effected in others.

TO the worker in pure science who finds difficulty in following the progress of applied science, the annual retrospects published in the technical journals are of special value. The most complete record of engineering progress is contained in the *Engineer* of January 3. The achievements in 1907 in the various branches of engineering practice are ably summarised, and illustrations are given of the most noteworthy works. A report on shipbuilding in

1907, published in *Engineering* of January 3, shows that in the United Kingdom 1499 ships, aggregating 1,795,400 tons (excluding three dockyard-built warships), and propelling machinery totalling 1,712,000 indicated horse-power, were turned out in 1907. A very complete record of progress in mining and metallurgy in 1907 is contained in the *Mining Journal* of December 28.

BULLETIN No. 14, on "Tests of Reinforced Concrete Beams," by Mr. A. N. Talbot, has just been issued by the University of Illinois Engineering Experiment Station. The tests described are a continuation of the tests discussed in Bulletin No. 4. The topics investigated include the effect of quality of concrete upon the strength of beams, the effect of repetitive loading upon the action of beams, and the resistance of beams to diagonal tension failures. The results of the investigation of diagonal tension failures throw light upon the amount of the vertical shearing stress which may be allowed in reinforced concrete beams not having metallic web reinforcement. The resistance of beams to diagonal tension may be the controlling feature of relatively short beams, and as such failures occur suddenly and without much warning, a knowledge of the resistance of the concrete is essential. Some beams gave surprisingly low values, and it seems evident that the values allowed by many city building ordinances are higher than should be recommended. The tests of concrete columns and reinforced concrete columns and of reinforced concrete T-beams for 1906 have already been published.

THE spell of frost which set in immediately after Christmas over the entire country was for the time severe, and the thermometer touched a lower reading than for several years past. The region of cold spread westwards from the continent of Europe. The Weather Report issued by the Meteorological Office for the week ending Saturday, January 4, covers nearly the whole period of the frost. It shows that the deficiency of temperature for the week amounted to more than 7° in the south and north-west of England, to nearly 8° in the south of Ireland, and to nearly 10° in the south-west of England. In many places the maximum temperature did not once reach 40° . The sheltered thermometer fell below 20° in all districts except the south of England, and in many parts of Scotland, Wales, and the north-west of England it fell below 15° , the lowest temperature reported being 10° , at Balmoral and West Linton. On the grass, the exposed thermometer fell to 2° at Balmoral. In the south-east of England, as well as at some places in the Midlands, the weather was still colder on Sunday, January 5, and the succeeding night. At Greenwich, the minimum shade temperature was 18° , and on the grass 10° . At Birr Castle, in central Ireland, the shade temperature was 12° , and at both Nottingham and Liverpool 16° . An exceptional rise of temperature occurred over the whole country on Monday, January 6, when the thermometer touched 50° in many places. There was a sharp fall of snow in London and the suburbs on the morning of yesterday.

In the *Annuaire Météorologique* for 1907, published by the Royal Observatory of Belgium, there is an interesting article by M. J. Vincent describing the upper-air investigations carried out by the Belgian observers by means of *ballons-sondes*. The instruments and methods employed are described in detail and illustrated, and the article will be found full of interest by all workers in this important branch of meteorology. Another article in the same publication deals with the humidity of the air in Belgium,

the subject being dealt with exhaustively and in a lucid manner. These special articles, and the large number of tables, &c., which the *Annuaire* contains, make the publication a very valuable reference work for meteorologists in general.

A SUMMARY of the results obtained from the meteorological observations made at the Catania Observatory during 1906 is given by Profs. Riccò and Cavasino in an extract from the *Atti dell' Accademia Gioenia di scienze naturali in Catania* (series 4a, vol. xx.). The actual readings and reduced values are given for each element, and in a series of notes they are compared with the analogous values for 1905.

PROF. RICCÒ has completed his gravitational survey of Sicily and Calabria, and published the results in the *Annale of the Central Meteorological and Geodynamical Office of Italy* (vol. xix., part 1.). The distribution of gravitational anomalies in Sicily is somewhat peculiar; in the centre there is a defect which reaches the greatest observed value of -67 at Caltanissetta, the unit being 0.001 mm. in the length of the seconds pendulum. Over the greater part of Sicily, however, the anomaly is positive, the lines of equal anomaly forming elongated ellipses with the longer axis running about N.E. and S.W., and cut off by the sea coast on the south. The anomaly reaches a positive value of 160 at Stromboli, and on the east coast off Syracuse, but there are some interruptions of the regularity of increase, the most important of which is on Mt. Etna. Round the foot of the mountain the anomaly has a positive value of about 70, which decreases on its slopes and sinks to -11 at the observatory near its summit. The magnetic survey of Sicily shows anomalies in the distribution of terrestrial magnetism, but as it is impossible to eliminate the magnetic effect of the superficial volcanic rocks, they cannot be correlated with those of gravitational attraction.

THE first part, just received, of the annual report for 1905 of the director of the Weather Bureau of the Philippines gives the results of hourly meteorological observations at the Manila Central Observatory during 1905. The hours of observations are given in insular standard time, that is, in the time of 120° E. longitude, adopted by order of the U.S. Government in 1899. The observations of atmospheric pressure, temperature, relative humidity, vapour tension, and the direction and force of the wind are hourly, read directly between 6 a.m. and 7 p.m., and from self-registering apparatus from 8 p.m. to 5 a.m. Each of the tables of hourly observations shows also the respective hourly, daily, and monthly means. The extreme daily values of the various elements, together with the times of their occurrence, are united in a separate table.

THOSE who in making measurements in which a spark gap has formed part of the apparatus have been troubled by the inconstancy of the results obtained, will welcome a simple device described by Dr. W. Eickhoff in the *Physikalische Zeitschrift* for December 15, 1907, which appears to increase the regularity of action of the gap to a very marked degree. It consists of a short piece of pointed wire, attached to the conductor carrying the negative sphere of the gap at a point close to the sphere, and bent over towards the positive sphere so that its pointed end is a little further away from the surface of that sphere than the two spheres are apart.

COMMUNICATION No. 99 from the physical laboratory of the University of Leyden contains two papers on the

variation of the electrical resistance of pure metals down to very low temperatures, by Prof. H. Kamerlingh Onnes and Mr. J. Clay. They find that the influence of very small amounts of impurities, although insignificant down to a temperature of -200° C., at lower temperatures becomes very marked. They express the effect by writing the resistance found equal to that of the pure metal plus a constant, depending on the amount and nature of the impurity. Platinum, gold, silver, lead, bismuth, and mercury have been tested between 16° C. and -260° C. and the results agree fairly well with those obtained fourteen years ago by Sir James Dewar and Prof. Fleming down to the temperature of liquid air. They differ considerably at low temperatures from the results recently published by Mr. G. Niccolai, of Pisa, and it seems probable that the differences are due to the latter not having expressed his temperatures in terms of the international constant-volume hydrogen scale.

MESSRS. N. ZANICHELLI, of Bologna, have published as No. 10 of their series of "Atualità Scientifiche" a recent address delivered by Prof. A. Righi before the Italian Society for the Advancement of Science; the lecture is entitled "New Views on the Ultimate Nature of Matter," and covers a wide field, dealing with the nature of atoms and electrons, and embracing the question of ordinary and colloidal solution.

THE Iron and Steel Institute has published in No. 3 of its journal a detailed account of the visits and excursions during the meeting of the institute held at Vienna in September last. The report contains a large number of interesting particulars of works and mines visited by the members, together with a great deal of information regarding the development of the iron and steel industry within the Austrian Empire; the account is illustrated by several photographs.

FROM Mr. A. B. Porter ("The Scientific Shop"), 324 Dearborn Street, Chicago, U.S.A., we have received a number of circulars containing descriptions and prices of a large number of pieces of physical apparatus, many of which are novel in character and for use in special experiments. The different sets cannot be mentioned here, but the catalogue is an interesting item for anyone engaged in science teaching or research; many of the sets of apparatus are well illustrated and described. Mr. Porter has also favoured us with his "Catalogue D," giving descriptions, illustrations, and prices of numerous optical parts. Telescope objectives and mirrors, prisms, echelon and diffraction gratings, photographic lenses, &c., are included in this list. As showing the enterprise of this firm, we would note that Mr. Porter quotes a price of 38,000 dollars for a paraboloidal mirror, grade A, of 84 inches diameter and 40 feet focal length; "prices of other sizes up to 10 feet in diameter will be quoted on request."

THE virtues of celluloid as a material suitable for the sharp and clean divisions of scales or slide rules, or in its transparent form as an edge for T-squares or for set-squares, are well known. Messrs. Casella and Co. have availed themselves of these properties, and of another, viz. that fine sharp lines may be ruled upon it with some opaque black dye, in the convenient area scale, White and Bean's patent, which they have put upon the market. This is nothing more than a group of parallel lines alternately full and dotted one-quarter of an inch apart. The set of parallel lines is laid over the figure the area of which is required, e.g. a steam-engine diagram, taking care that it is so placed that the extremities of the area

lie half-way between a pair of lines on each side. Then the sum of the included lengths of all the parallel lines is found by marking them off on the edge of a strip of paper. The total length in inches divided by four gives the area in square inches. In order to avoid the necessity of dividing by four, a scale is attached in which the unit distance is 4 inches, and this is divided into one hundred parts, and so by direct application of the strip of paper to this scale the area may be read directly. Alongside of the inch scale is another scale of equal parts such that the length of 4 inches read on this scale appears as 6.45. From this, therefore, square centimetres may be read. When less accuracy is required, alternate lines only need be used, and the result multiplied by two. In the example submitted the linear dimensions are all short by 1 in 150, which would make the areas come out too much by 1 in 75.

THE current issue of Mr. Charles Baker's quarterly catalogue of second-hand optical and other instruments is now available. The list contains particulars of about 1250 pieces of apparatus on sale in this particular department of Mr. Baker's establishment.

THE list of electrical novelties just published by Messrs. F. Darton and Co., of St. John Street, London, E.C., contains numerous illustrated descriptions of pieces of electrical apparatus likely to prove acceptable presents to boys with interest in science. The catalogue also includes various applications of electricity to domestic purposes, in addition to many different patterns of widely used electrical instruments.

MESSRS. JAMES WOOLLEY, SONS AND CO., LTD., publish a compact and useful "Reference Book and Diary for 1908," intended for science teachers and students. The pocket-book contains many convenient tables of constants, brief hints as to the use of instruments, "first-aid" notes, and some advertisements, in addition to the usual form of diary. The price of the book is one shilling bound in cloth and two shillings in leather covers.

THE "Science Year-book and Diary for 1908," edited by Major B. F. S. Baden-Powell, and published by Messrs. King, Sell and Olding, Ltd., contains 152 pages of useful scientific information, a full-page diary for the year—each page being provided with useful astronomical and meteorological data for the day—and numerous blank pages for notes, cash-accounts, and other memoranda. The frontispiece is a portrait of Sir Norman Lockyer, K.C.B., F.R.S. New names have been added to the biographical section, but it is difficult to understand what plan has been adopted in selecting names for inclusion in this list. The price of the volume is 5s. net.

MESSRS. NEWTON AND CO., 3 Fleet Street, E.C., have submitted to us a specimen of an instrument termed the "Vitascope," devised for the examination of small living creatures under natural conditions. The instrument is in the form of a telescope, about $1\frac{1}{2}$ inches in diameter and a foot in length when closed, and by a novel combination of lenses it enables a magnification of about twelve diameters to be obtained at a distance of 20 inches from the object under observation, and sixty diameters at a distance of about 5 inches. With these magnifications, the observation of insects in flowers or of other small living objects, at a suitable distance from them, becomes a pleasurable and instructive pastime. The instrument has a pillar, which can be screwed upon the top of an ordinary camera stand for use in the garden to observe the struc-

ture or movements of living creatures conveniently. It should be of real assistance in the study of numerous small forms of animal life under natural conditions.

MESSRS. CHARLES GRIFFIN AND CO., LTD., have published the twenty-fourth annual issue of the "Year-book of the Scientific and Learned Societies of Great Britain and Ireland." The work is, as usual, compiled from official sources, and according to the title-page provides a record of the work done in science, literature, and art during the session 1906-7 by numerous societies and Government institutions. It is surprising to find, however, that in connection with the British Association, the only information in the book is confined to the proceedings of the York meeting in 1906, and no mention is made of the Leicester meeting in August last. Under societies concerned with geography, the Geographical Association is not included, though its membership is now nearly 650, and it has branches in various parts of this country and in South Africa. But notwithstanding such defects, which can be remedied easily in the next issue, the compilation should continue to be of real assistance as an index to British scientific associations and their work.

A LIST of publications of the Carnegie Institution of Washington, already issued or in the press, has just been received; and it reminds us of the very useful work the institution is doing by the publication of monographs on many scientific subjects of wide and deep interest. About ninety of these memoirs have been published, and most of those containing contributions to natural knowledge have been described in the columns of NATURE. Among the works now in the press, we notice an atlas of the Milky Way, E. E. Barnard; dynamic meteorology and hydrography, V. Bjerknes and J. W. Sandström; the rotation period of the sun, as determined by the motion of the calcium flocculi, G. E. Hale; inheritance in canaries, C. B. Davenport; supplementary investigations of infrared spectra, W. W. Coblentz; and botanical features of North American deserts, D. T. MacDougall. The publications are sold at a nominal price, and a list can be obtained upon application to the Carnegie Institution of Washington, Washington, D.C., U.S.A.

OUR ASTRONOMICAL COLUMN.

RETURN OF ENCKE'S COMET (1908a).—A telegram from the Kiel Centralstelle announces that Encke's comet was found by Prof. Wolf on January 2.

Its position at 6h. 14.5m. on that date (Königstuhl M.T.) was R.A.=23h. 3m. 16s., dec.=1° 19' N., and its magnitude was 13.0.

The following is an abstract from the ephemeris given in No. 4222 of the *Astronomische Nachrichten*:—

Ephemeris oh. (M.T. Berlin.)					
1908	α (app.) h. m.	δ (app.)	log r	log Δ	
Jan. 11	23 8.8	+ 2 21.9	0.2829	0.3461	
" 19	23 17.4	+ 3 7.8	0.2617	0.3477	
" 27	23 27.1	+ 4 3.1	0.2385	0.3469	
Feb. 4	23 38.1	+ 5 7.5	0.2130	0.3435	

At present the comet is apparently passing through the constellation Pisces towards Aries, and sets nearly due west at about 10 p.m. The calculated time of perihelion passage is April 30, not February 22, as stated in our last issue.

SAURUS'S RINGS.—No. 4222 of the *Astronomische Nachrichten* (p. 361, December 18, 1907) contains further notes on the recent appearance of Saturn's rings.

The Rev. T. E. R. Phillips states that on many occasions since the middle of October he has seen the ring clearly, as an extremely fine line of light on each

side of the planet, with his 12-inch Calver equatorial. This line was not always uniformly luminous, but appeared continuous except on November 8, when an interruption on the following side was suspected. He believes the present visibility of the ring to be due to the sunlight passing through the Cassini division and illuminating the edge of the second ring, which is the brightest part of the system.

Dr. Lau gives the results of a number of micrometer observations of the minor axis of the rings, for position-angle, from September 3 to 28, 1907, and shows the differences between the observed and the Nautical Almanac values. The rings were seen on October 2 at 0.2h., but were invisible on October 3 at 23.1h.

THE SPECTRA OF TWO METEORS.—Using a prismatic camera made up of a Voigtlander eyroscope, of 50 mm. aperture and 300 mm. focal length, with a 45° crown-glass prism placed before it, M. Blakjo, of the Moscow Observatory, obtained the spectrum of a meteor on May 11, 1904; with another camera an ordinary trail photograph was obtained at the same time. Encouraged by this chance fortune, M. Blakjo directed his cameras towards the Perseid radiant on August 12 of the same year, and was fortunate enough to secure a second meteor spectrum.

In the first case the meteor was of about the first magnitude, and of a yellow colour, and the spectrum consists of fine lines, of which, by an ingenious method of comparison with the hydrogen lines shown in the adjacent stellar spectra, M. Blakjo determined the approximate wave-lengths to the number of thirteen.

The second meteor was equally bright and of a pure green colour; during the second half of its flight it was considerably brighter than at first, and this increase of brightness increased the number of lines shown in the spectrum; the wave-lengths of ten certain and three doubtful lines were determined, and on comparison it was found that the emission spectra of the two meteors are entirely different from each other.

In the spectrum of the first meteor, the calcium lines H and K are the brightest, and are accompanied by the line at λ 4227; magnesium and potassium are also apparently represented. Helium is apparently the outstanding feature of the spectrum of the second meteor, the lines at $\lambda\lambda$ 3810.8, 3888.8, 3964.9, 4026.3, and 4121.0 being represented. M. Blakjo accounts for the pure green colour of this object by the presence of the thallium line at λ 3775.9 in its spectrum (*Astrophysical Journal*, vol. xxvi., No. 5, p. 341, December, 1907).

THE CONSTANCY OF WAVE-LENGTHS OF SPECTRAL LINES.—The importance of the constancy of wave-length of spectral lines in astronomical, as in terrestrial, spectroscopy leads Prof. Kayser to discuss the question in No. 3, vol. xxvi., of the *Astrophysical Journal*. He points out that Exner and Haschek based some of their recent evidence for variation on differences obtained by students in his laboratory, and states that, in his opinion, these differences were probably due to errors of the standards employed rather than to any real variability of wave-length. Prof. Kayser also adduces evidence, based on the recent work of Dr. Pfund and of Prof. Fabry, in support of his view that "the question of the constancy of the wave-lengths is finally settled."

NEW CHEMICAL LABORATORIES AT ABERYSTWYTH.

THE Edward Davies chemical laboratories at the University College of Wales, Aberystwyth, which were formally opened on November 1 by Mr. Asquith (see this vol., p. 22), have been erected at a cost of 23,000l. by Mr. David Davies, M.P., his mother and sisters, to the memory of the late Mr. Edward Davies, J.P., and have been handed over to the governing body of the University College of Wales. The laboratories are under the direction of Prof. J. J. Sudborough, and have been in use since the opening of the present session on October 2.

The laboratories form a separate block of buildings about half a mile distant from the college, and are erected in local stone with Grinshill dressings. On the first floor are two large laboratories (50 feet by 40 feet), each con-

taining eight double benches (11 feet by 5 feet), so that sixty-four students can work simultaneously; adjoining are balance rooms and a combustion room. The laboratories are well provided with fume cupboards, placed in the window recesses, and ventilated by two main electric "blowers" placed in dormers at the ends of the building. On the same floor is the departmental library (26 feet by 15 feet), which contains complete sets of all the more important English and foreign chemical periodicals, in addition to important general works of reference. The main lecture theatre is situated at the back of the building on the first floor; it is provided with lift-up seats for 130 students, and adjoining it are the preparation room and museum.

On the ground floor are the following rooms:—the physical chemical laboratory, the director's private room and private laboratory, distillation room, two dark rooms, general stores, special stores, porter's room, demonstrator's private laboratory, lecture room with accommodation for fifty students, and two small research rooms. In the basement are a small metallurgical laboratory, extra stores, a fire-proof room, a small dynamo room, and a mechanic's room.

The physical chemical laboratory has a central table 12 feet by 5 feet, with no reagent shelves. Around the walls are slate slabs and wooden tables. The slate tables



The "Edward Davies" Chemical Laboratories, University College of Wales, Aberystwyth.

are provided with several thermostats regulated for different temperatures. The room also contains a fume cupboard for electrolytic work, and a main accumulator board. This board carries the terminals of twenty Tudor cells placed in the adjacent room. The cells are charged from a small motor generator in the basement, and are in groups of one, two, and four. The accumulator board also carries the terminals of eight working positions, four in the physical chemical laboratory and four in one of the large laboratories, and, in addition, three main terminals for the lecture theatre and the motor generator terminals. The terminals are so arranged that any position in the theatre, large laboratory, or physical chemical laboratory can be connected to any group or combination of groups of cells, and also, if necessary, to the motor generator terminals.

The distillation room has no gas connections, but has a long slate slab provided with water, steam, current (220 volts), and waste. It is used for the distillation of large quantities of inflammable liquids, and the source of heat is either steam or electric current. The fire-proof room is furnished with slate slabs and an iron fume cupboard. Experiments necessitating the use of gas during the night are conducted in this room. The gas connections for this room and for the chemical physical laboratory are so arranged that flames may be left burning in these rooms

when the main gas supply is shut off for the night. The general heating is by means of hot-water pipes, and the lighting by means of tantalum lamps.

The laboratories are especially arranged to give students a sound training in the various branches of chemical study, and are also admirably suited for the carrying out of original investigations. At present about eighty students are working in the laboratories, and of these five are engaged in research work, mainly on the relationship between constitution and the velocity of reaction of carboxylic acids.

SCIENTIFIC WORK OF THE LOCAL GOVERNMENT BOARD.

THE supplement to the thirty-fifth annual report of the Local Government Board, 1905-6, contains the report of the medical officer for 1905-6. The contents of this valuable volume are briefly summarised in the excellent introduction contributed by the principal medical officer, Mr. Power.

An account of the general administrative business of the medical department is given in Appendix A, which includes reports on the outbreaks of enteric fever at Basingstoke and at Lincoln.

Appendix B contains an account of the auxiliary scientific investigations carried out for the Board, of which three are contributed by Dr. Klein, and deal with plague. The first and second of these form a further contribution on the value of a new plague prophylactic prepared from the dried organs of plague-infected animals, as previously detailed by the author, who concludes that it would appear that the injection of rats with efficient material—the raw or the heated filtrate of emulsions of dried plague organs—in appropriate doses has proved protective in as short a period as seven days against subsequent cutaneous inoculation of virulent *B. pestis*, that is, against plague infection administered in the most effective manner. Further, it appears that the protection thus afforded, though inducible so speedily, may be trusted to persist many days, and even weeks. The prophylactic having been proved to protect rats was also tested on monkeys in order to ascertain whether or not there was promise of its application to the human subject proving salutary and justifiable, and 25 milligrams of dry material sufficed to protect against a supra-lethal dose of virulent plague bacilli. As regards the rat, Dr. Klein finds that various species of rat are differently susceptible to the *B. pestis*, the Norway rat apparently being less susceptible than certain other races.

Dr. Gordon reports on the micrococcus of epidemic cerebro-spinal meningitis ("spotted fever"), with special reference to its identification in the upper respiratory passages. The morphological and other characters of the meningococcus are fully described, and its differentiation from other somewhat similar cocci by means of fermentation reactions on various sugars is detailed.

Dr. Sidney Martin has continued his studies on the chemical products of micro-organisms, and reports on the products of the *Bacillus enteritidis sporogenes*. The experiments show that the poisonous products of this organism do not consist of an endo-toxin, but of a soluble chemical and non-protein substance which is formed by the bacillus by its action on proteins. Dr. Wade contributes an exhaustive experimental inquiry on sulphur dioxide as applied in the destruction of rats and in disinfection on shipboard. The conclusion is formulated that a modification of the Clayton apparatus (described in the report) to supply dilute sulphur dioxide will prove the best adapted to practical requirements.

The last paper, by Drs. Andrewes and Gordon, discusses

the biological characters of the staphylococci pathogenic for man, and tests that will be useful for their differentiation are described.

It will thus be seen that the report contains matter of considerable scientific and practical interest, and it would be a great pity if this work were to be discontinued in the future, as has been rumoured it may be.

R. T. HEWLETT.

MENDELISM AND SEX.¹

ALL science is founded on observed facts. All authenticated facts, no matter how observed, are valuable to science. Many invaluable facts cannot be observed without the aid of some special method, for example, experiment; but, of the total mass of facts garnered by science, data furnished by experiment form a very small part. Therefore to rely solely on experiment is to put on blinkers.

Since species are able to exist in their environments, they are adaptational forms. The more minute our knowledge of a species, the more certainly are we able to assign past or present utility to nearly all its structures and faculties. Adaptation extends deeper than structures and functions. Variability itself is adaptive. A greater or lesser degree of variability is a variation and material for natural selection. There is satisfactory evidence that the average degree of variability displayed by every species and structure is controlled by selection. The mass of variations are "spontaneous." Thus there are hundreds of human races and diseases, and every race is resistant to every lethal disease in proportion to its past experience of it. Therefore in this case there is adaptation. Therefore it is clear that the poisons of disease, no matter how virulent or universally experienced by the race, do not cause alteration in the germ-plasm, and consequent racial degeneration. On the contrary, since adaptation has occurred, it is plain that variations are spontaneous, and, since diseases are so many, that they occur all round the specific mean. But some races (e.g. European dogs in India) have been known to degenerate when removed to new environments, where the native races flourish. Therefore the insusceptibility of the germ-plasm to the direct action of the environment has been established by natural selection, and this, combined with the facts that (1) species tend to become more variable a few generations after removal from ancestral environments to which they have become closely adapted, and where, therefore, nature limits variability; (2) the degree of variability in functionally correlated structures (e.g. pairs of limbs) tends to be correlated; and (3) the greater the need for adaptation the less is the degree of variability when once adaptation has been attained (e.g. head and fore-foot of squirrels as compared to tail), affords plain evidence that variability is under the control of natural selection.

When cessation of selection as regards any character occurs, that character tends to retrogress. Therefore retrogressive variations tend to predominate over progressive variations, whereby, without an increase of mortality, species are rid of redundancies, both useless variations and old-established parts which have become useless. Since this tendency to retrogression is highly adaptive, the presumption is that it is an adaptation. That the retrogression which follows panmixia is not due to reversed selection is shown by the fact that, though variations favourable against all diseases occur in every human race, yet they retrogress unless preserved by selection, for races become resistant only to those diseases to which they are exposed.

The two central doctrines of Mendelism are:—(1) segregation of units, and (2) independent inheritance of characters. Taken by itself, the doctrine of segregation assigns no function to conjugation. It merely controverts the doctrine of blending. Taken with the doctrine of independent inheritance, it assigns to conjugation the function of effecting an exchange of germinal units between the two sets of parental units. That much Mendelism implies—that much and no more. Mendelians believe,

apparently, that they have found the key to all the problems of heredity; but obviously Mendelism is concerned with nothing more than the function of conjugation. No other problem of biology with which it is concerned can be thought of. However grandiose the language used by its adherents, they are quite unable, when challenged, to indicate any other.

Mendelian inheritance is common when varieties which have arisen under artificial selection are crossed. It is comparatively rare when natural varieties (e.g. human) are crossed. Blending is then the rule. Latent traits, also, are commonly revealed by the crossing of artificial varieties. In the whole range of biological literature, no instance is recorded of a latent trait being revealed by the crossing of natural varieties. Even when artificial varieties are crossed, they never revert beyond the wild variety; that is, they never reveal traits that were latent in the wild variety. Presumably, therefore, characters become latent only under artificial selection, and consequently Mendelism is concerned, not with the main problem of conjugation, but only with certain anomalies which occur under conditions of artificial selection.

It is admitted on all hands that artificial selection is founded mainly on mutations, and that the inheritance of mutations tends to be alternative. It is admitted that the inheritance of fluctuations tends to be blended, and the evidence is conclusive that natural selection builds on fluctuations. Thus varieties are most numerous when mating individuals (e.g. birds) are enabled by good powers of locomotion to interbreed over a wide area. No interpretation of these facts save that of blending can be thought of. Human varieties, for example, arise only under conditions of geographical isolation. It has been said, on the evidence of half-a-dozen generations, that mutations are stable, and having arisen can be eliminated only by selection. This implies that only progressive variations occur in nature, and therefore that no structures ever disappear or retrogress except through reversed selection; but though variations favourable against all diseases occur in all human races, only those which are selected are preserved and contribute to evolution. Therefore it is clear that the rest retrogress, though there can be no reversed selection in this case.

When species are sexually dimorphic, mating individuals differ, as a rule, little in non-sexual characters, but much in sexual characters. Offspring reproduce either the paternal or the maternal sexual characters. That is, the reproduction of sexual characters is alternative, the male and female characters being "allelomorphic" to one another. But the inheritance of them is not alternative, for each sex inherits the characters of the other in a latent state, as is proved by a mass of evidence. Therefore, though in bi-parental reproduction there is apparently no blending as regards the sexual traits, yet the fact is that the patent characters of the one sex blend with the latent characters of the other. Sometimes the male characters are latent for a long series of generations, as in aphides, or apparently permanently, as in *Cypris reptans*. A mutation, like a sexual difference, is a large difference, and when an individual mutates and mates with the parent type, the reproduction of the mutation tends to be alternative. But the evidence is massive that the inheritance is not alternative, but, on the contrary, that the mutation is latent in those lines of descent which follow the parent type, whereas the ancestral trait is latent in those lines which follow the type of the mutant. Like the sexual traits in bi-parental reproduction, the recessive is temporarily latent in the impure dominant. Like the male characters in aphides and *Cypris reptans*, it is more or less permanently latent in "pure" dominants, as is the dominant character in the recessive. This is proved by the occasional occurrence of recessives in lines of "pure" dominants, and *vice versa*. It is even more decisively proved by the reproduction of latent ancestral characters, especially when (artificial) varieties are crossed. Cuenot's theory of colour factors attempts to interpret in Mendelian terms this fact of the reproduction of latent ancestral traits, but his hypothesis totally fails to account for the reappearance of latent ancestral traits in pure lines of descent, as, for example, when an aged female bantam reproduces, not the secondary male characters of her own variety, but those of an ancestral type. Here there can

¹ Abstract of a paper read before the Linnean Society on December 19, 1907, by G. Archdall Reid.

have been no antecedent separation of factors. Therefore the evidence is that mutations tend to be inherited in the mode of sexual characters. There are, however, differences. Sexual characters tend to alternate more perfectly, to cohere together in their respective sets more closely, and to have a lesser tendency to blend with their opposite numbers than Mendelian characters; but this is only what might be expected, for the mode of inheritance for sexual characters has been established by stringent selection. Some sexual characters, however, sometimes blend or change places with their opposite numbers, as in so-called human hermaphrodites; the dominance of some Mendelian characters is very imperfect; reciprocal Mendelian crosses sometimes produce unlike results; and the inheritance of some Mendelian characters (e.g. colour-blindness) is sexual. Were their occurrence the rule, not the exception, we would speak of them as sexual characters. Properly speaking, Mendelian characters are non-sexual traits which are reproduced in the sexual mode. If, however, we examine any list of so-called Mendelian characters, we find that the majority may fairly be described as secondary sexual characters, though not necessarily as sexual differences, for example, colour and form of plumage. It seems clear, then, that there is no real segregation, no real alternative inheritance, but only alternative reproduction, alternative patency and latency. Therefore blending is universal. Unless the reappearance of ancestral traits can be explained, the bottom falls out of the Mendelian hypothesis. Nevertheless, Mendelian facts are very valuable, inasmuch as they indicate the difference between natural and artificial selection. The experimental observer is able to note only large differences between mating individuals. In practice, he has almost limited his materials for study to domesticated varieties. He has altogether ignored fluctuations. Hence the mutation and Mendelian theories.

It is possible that mutations are more common amongst artificial than amongst natural varieties, in which the range of variability is more stringently limited. But amongst the entirely natural varieties of the species we know most intimately (man) mutations are common enough, and their reproduction tends to be Mendelian. But all are so injurious in the struggle for existence or for mates that when possible they are treated surgically. Never yet has a useful human mutation been recorded. Man has a written history of thousands of years, and human varieties differentiate whenever geographical isolation is sufficiently complete and prolonged. Men are fond of noting wonders. But, notwithstanding the immense range of material, never yet has the origin of a human variety by mutation been recorded. It is easy to conceive of evolution as resulting from mutations when we limit our materials of thought to the colours and shapes of flowers and leaves of plants which are preserved under human care. It is not so easy to think of it as founded on mutations when we take into account the exquisitely co-adapted internal parts of a complex animal, amongst which a mutation would have the same effect as one occurring in one of the parts of a watch.

The extreme instability of fluctuations has been noted and has furnished a main argument to the supporters of the mutation theory. There is abundant reason for believing that in a blend the retrogressive character tends to predominate. Thus racehouses degenerate unless carefully selected. Suppose a country in which malaria is prevalent and another from which it is absent. In the former, variations favourable against malaria are selected; like mates with like; therefore blending causes little or no retrogression, and the mean of the race is raised in each generation. In the latter, though favourable variations occur, unlike individuals mate; therefore blending causes retrogression, and the race is rid of a useless redundancy. Apply this reasoning to all variations and all characters, and the function of conjugation becomes apparent. It is, in effect, a selective agent of retrogression. Selection rough-hews the type; retrogression chisels out the finer lines. Reproduction is bi-parental in all the higher and more complex forms in which nature's task of closely adjusting the numerous co-adapted parts is most difficult.

If we accept the theory of blended inheritance, we are able to assign a useful function to conjugation. But to

both the Mendelian and the mutationist, sex is a phenomenon to be explained away. According to the former, conjugation merely jumbles together elements which may be incongruous. According to the latter, conjugation is nothing other than an obstacle to the survival of mutations, which have the best chance of surviving when reproduction is parthenogenetic. It has been said by some Mendelians and mutationists that fluctuations are due merely to temporary effects of nutriment, temperature, and the like; mutations alone are permanent. How, then, is it possible to explain the fact that when reproduction is parthenogenetic "thousands of forms may be cultivated side by side in the Botanical Gardens, and exhibit slight but undoubted differentiating features, and reproduce themselves truly by seed" (de Vries)? This does not happen when reproduction is bi-parental. It can hardly be contended that mutations are a thousand-fold more numerous when reproduction is parthenogenetic than when it is bi-parental. We are driven to the conclusion that the fluctuating nature of fluctuations when reproduction is bi-parental is due to the retrogression caused by blending. The seeming permanency of mutations is due to their mode of reproduction. They take longer to retrogress than fluctuations only because they are bigger. All latent characters, since they are not selected, tend to retrogress.

UNIVERSITY AND EDUCATIONAL INTELLIGENCE.

PROF. ADOLPHE CARNOT, lately director, and for many years professor, of chemistry at the Paris School of Mines, has retired with the title of honorary director of the school.

It is announced, says *Science*, that Mr. Emile Berliner, of Washington, the inventor of the gramophone, has given £2500, as endowment of a research fellowship for women who have demonstrated their ability to carry on research work in physics, chemistry, or biology.

A RESEARCH scholarship or scholarships, founded by Mr. Andrew Carnegie, will be awarded shortly, irrespective of sex or nationality, on the recommendation of the council of the Iron and Steel Institute. Candidates, who must be under thirty-five years of age, must apply on a special form before the end of February to the secretary of the institute, 28 Victoria Street, London, S.W. The object of this scheme of scholarships is not to facilitate ordinary collegiate studies, but to enable students, who have passed through a college curriculum or have been trained in industrial establishments, to conduct researches in the metallurgy of iron and steel and allied subjects, with the view of aiding its advance or its application to industry.

The sixth annual meeting of the North of England Education Conference was opened at the University of Sheffield on January 3, under the presidency of Prof. M. E. Sadler. After the presidential address, Prof. Hicks read a paper on the function of a modern university, and Dr. R. H. Crowley (Bradford) and Dr. Clement Dukes (Rugby) dealt with medical inspection of school children. Other subjects discussed were holiday and open-air schools, compulsory attendance at evening schools, and the teaching of history. On the following day Sir William Clegg presided, and the morning sitting was devoted to consideration of the work of training colleges. The afternoon topics were:—(1) the treatment of defective children; (2) house-craft in girls' schools; (3) artistic perception in children.

The London County Council Conference of Teachers was held on January 2, 3, and 4, when more than 1200 visitors signed the attendance book, and as this was the tenth of these annual meetings, it is clear that their utility is appreciated. With a very liberality, the County Council promises to send a verbatim report of the proceedings to those who attended the conference, of which a noteworthy feature was the frank cordiality with which the Council inspectors and teachers interchanged views. The principal topics discussed were the place of nature-study in the curriculum, the study of botany by girls, the commercial education of boys, manual instruction for young children, practical suggestions for school library management, and recent pedagogic experiments in the study of literature and of open-air geography.

SOCIETIES AND ACADEMIES.

LONDON.

Royal Society, November 7, 1907.—“Further Results of the Experimental Treatment of Trypanosomiasis in Rats: being a Progress Report of a Committee of the Royal Society.” By H. G. Plimmer and J. D. Thomson. Communicated by Sir Ray Lankester, K.C.B., F.R.S.

The following results carry the work, part of which has been already described, on to October 24, 1907.

Rats treated with atoxyl and mercury are still living and well at 229, 222, 208, 178, 164, and 63 days after inoculation; and a rat treated with atoxyl and iodipin is alive at 218 days.

The principal pathological lesion in rats which have been treated with atoxyl and some compound of mercury and have lived for a very long time after inoculation, apparently cured of the disease, is a degeneration of the kidneys; and in most of these rats this was the only lesion found *post mortem*.

Considering both the experiments already recorded which have since ended fatally, and the more recent and—as regards dosage—bolder experiments, the authors are prepared to conclude that, in small animals at any rate, mercury has not given altogether satisfactory results. Perhaps it may be a question of dosage; they have, however, tried to enlarge the range of dosage as far as possible, from homeopathic to large ones, without attaining a large percentage of cures. If the dose of mercury be sufficient to aid the atoxyl, they have found, in those cases which have died, chronic kidney, and in a less degree liver, lesions, which seem to be the late result of those more acute changes which have been found in those animals that have died earlier, either from disproportionate dosage, or from some want of resistance to the drug.

Potassium antimonyl tartrate has been tried, and this was found to be fatal to rats in doses of 1 centigram. The trypanosomes were observed to be greatly diminished in numbers, but it was also noticed that soon after the injection the rats appeared to be very ill. This was attributed at the time to the potassium in the compound; probably erroneously, as a similar effect has been noticed in rats treated with the compound described below, when the number of trypanosomes in the blood was very great. The symptoms may have been due to the dissolution of so large a mass of trypanosomes. But they suggested the use of the sodium compound—sodium antimonyl tartrate—with which many experiments have been made.

This substance in 1 per cent. solution is that which, of all the various bodies tried, including atoxyl, has the most marked influence upon trypanosomes in the living body. Although the experiments with it are not many, or of long duration, the results so far seemed sufficient to induce the authors to direct the attention of other workers in this field to it.

The question of dosage is still under observation. The authors have tried many ways, and at present are inclined to think that a full dose (e.g. 0.5 c.c. of a 1 per cent. solution for a rat of 200 grams or over) should be given when the trypanosomes are fairly plentiful in the blood, and then repeated at intervals of one, two, and three days, up to about four doses, and thereafter in weekly doses for a month. But they have good results in cases in which a dose has been given on four successive days, also when given every other day, and so on up to once every five days, without any recurrence up to as many as 52 days; but of two cases dosed at five-day intervals, one has recurred and one has not.

The quickness of the action of sodium antimonyl tartrate is remarkable. In one rat, the blood of which was swarming with trypanosomes, a dose of 0.35 c.c. of a 1 per cent. solution caused their entire disappearance from the blood within half an hour; and in two other cases, in which the blood contained very large numbers of trypanosomes, after injection of 0.33 c.c., only a few could be found at the end of half an hour, and in one after an hour none could be found, and in the other only one in an ordinary blood preparation. A few trypanosomes can sometimes be found in the liver, and these are extremely active, and in no way inconvenienced by the drug; whether these are the forms which can persist,

and need to be tired out by successive doses, cannot be said at present, but their extreme activity, when all the others have disappeared, is suggestive. The authors have not detected any morphological differences in them.

A guinea-pig, moribund with sleeping-sickness, with œdema of eyelids and genitals, entirely unable to stand, and with a large number of trypanosomes in the blood, was given, on September 16, 0.5 c.c. of a 1 per cent. solution; on September 17 the trypanosomes had entirely disappeared, and 0.75 c.c. was given; on September 19 the animal to all appearances was quite well, and on this day and on September 21 and 26, 1 c.c. was given. The œdema disappeared and it continued to look well, and showed no more trypanosomes. It lived until October 14, when it died; *post mortem* the organs were congested and the kidneys were inflamed, and the urine in the bladder contained albumen. The fact that the guinea-pig was moribund when the treatment was commenced may reasonably account for the pathological conditions.

Of 36 rats treated with sodium antimonyl tartrate, 11 have died, 6 not of the disease, and there remain alive and well: 3 of 52 days, 1 of 49, 7 of 44, 8 of 43, 4 of 31, and 2 of 21; and of these 25, 23 have had no recurrence.

With the view of ascertaining what amount of immunity, if any, had been conferred on an animal which was considered to be cured, a nagana rat was taken which was inoculated on May 13, and had been afterwards successfully treated with atoxyl and succinimide of mercury, and in which no trypanosomes had been found since it had its first dose on May 16, when the trypanosomes were very plentiful in the blood. On October 7, the 147th day, the rat was re-inoculated from another nagana rat, and on October 11 trypanosomes were present in numbers in the blood; a dose of sodium antimonyl tartrate was given, and no trypanosomes have been seen since October 12. This seems to point to the fact that no immunity is conferred.

December 12, 1907.—“Magnetic Declination at Kew Observatory, 1890-1900.” By Dr. C. Chree, F.R.S.

The paper deals with the phenomena exhibited by the magnetic declination at Kew from 1890-1900. The magnetograph curves have been measured on every day of this period, whether disturbed or undisturbed, and the data from days of the different species are contrasted. Diurnal inequalities are got out for ordinary days, excluding those of large disturbance, and separately for the highly disturbed days, and the differences between these, and the points wherein they differ from the corresponding inequalities from quiet days, are investigated.

The disturbed days show a well-marked regular diurnal variation, which differs in many notable respects from that observed on ordinary days.

When the inequalities are analysed in Fourier series, it is found that the difference mainly centres in the twenty-four-hour term, the amplitude and phase of which seem both largely influenced by disturbance. The variations in the phenomena presented by disturbances throughout the year are investigated from several points of view.

The absolute range of the declination (absolute maximum less absolute minimum) was determined for every day of the eleven years, and special attention is given to the variation of this quantity throughout the year, and from year to year. With the view of throwing light on the theories of Arrhenius, Maunder and others, on the origin of magnetic storms, a minute comparison is made of the relationship between the absolute ranges and (Greenwich) sun-spot areas throughout the eleven years. Whilst the results do not preclude the possibility that Arrhenius's theory may be true of a certain number of magnetic storms, they seem to indicate that it cannot be a complete explanation of the facts.

Chemical Society, December 10, 1907.—Sir William Ramsay, K.C.B., F.R.S., president, in the chair.— β -N— β
Attempted synthesis of β -dinaphthacridine; condensation of methylene dichloride and 1-substituted-2-naphthylamines: A. Senier and P. C. Austin. By condensing methylene dichloride with derivatives of β -naphthyl-

amine in which the hydrogen of the α -position adjacent to the amino-group had been substituted by a halogen, either Reed's dinaphthacridine or a meso-derivative thereof was formed, thus completing the proof that this base has the constitution assigned to it.—**Cobaltamine compounds** (preliminary note): C. E. **Groves**. Carycino-cobaltamine carbonate is produced when freshly precipitated cobalt carbonate suspended in dilute ammonia is agitated with air and then exposed to the air for three or four days, in the form of bright crimson crystals. When the crimson carbonate is treated with excess of nitro-hydrochloric acid it is ultimately converted into "bluish-black" crystals. A bronze-green nitrate is prepared by gradually adding a solution of cobalt nitrate in dilute nitric acid to a mixture of dilute ammonia with a solution of ammonium sulphate, and, after it is thoroughly oxidised by shaking it with air, acidifying the mixture with dilute nitric acid. The bronze-green hydrochloride is easily obtained from the nitrate by heating the latter with dilute hydrochloric acid. A grass-green compound obtained from purpureo-cobaltic chloride is also described.—The direct interaction of aryl halides and magnesium: J. F. **Spencer** and Miss E. M. **Stokes**. The authors find that the Grignard reaction between cyclic halogen compounds and magnesium powder takes place without the use of ether when the two substances are heated together. In the case of aliphatic compounds, methyl iodide, methylene iodide, and isopropyl iodide were indifferent, but bromosuccinic acid gave succinic acid.—Derivatives of tetramethyl glucose: J. C. **Irvine** and Miss A. M. **Moodie**. The constitution of tetramethyl glucoseoxime, deduced from its behaviour on alkylation and the hydrolysis of the product, shows that it is produced by the reaction of the sugar in its γ -oxidic forms, and this also seems to be the case with tetramethyl glucoseanilide. It was found that the silver oxide method of alkylation can be applied to the methylation of oximes, thus furnishing a convenient method of determining the hydroxyl content of such compounds.—The characterisation of mercerised cotton. Preliminary note: J. **Hubner**. After treatment with iodine in potassium iodide, mercerised cotton becomes brownish-black, whilst cotton remains white. Similarly, non-mercerised cotton remains practically white, whilst the mercerised material becomes dark navy-blue on treatment with iodine in zinc chloride solution.—Note on the action of metallic calcium on alcohols: F. M. **Perkin** and L. **Pratt**. The statement that metallic calcium has no action on alcohol is inaccurate. With ethyl or methyl alcohol, after from thirty to sixty minutes, reaction ensues, and may become very vigorous, a calcium alkoxide being formed.—Note on the iodates and periodates of the alkalis and the ammonium radicle: T. V. **Barker**. Specific gravity and solubility determinations of the iodates of rubidium and caesium, and the periodates of sodium, potassium, rubidium, caesium, and ammonium, are given.—The colour of cupric salts in aqueous solution: N. V. **Sidgwick** and H. T. **Tizard**. From the results obtained, it seems probable that ionisation affects the intensity of the colour but not the tint.—Derivatives of S-phenylphenazothionium, part I.: S. **Smiles** and T. P. **Hiditch**.—A colorimetric method for the determination of small percentages of iron in copper alloys: A. W. **Grogory**. The method is based upon the colour reaction given by salicylic acid and ferric chloride. The interfering action of the blue copper salts is overcome by the addition of a weak solution of potassium cyanide. Zinc and antimony do not interfere with the reaction, but lead must be removed as sulphate.—The effect of heat on the alkyl iodides: Z. **Kahan**.—The influence of acids and alkalis on the velocity of formation of acetoxime: E. **Barrett** and A. **Lapworth**.—Action of metallic calcium on ketones: H. D. **Law** and F. M. **Perkin**.—The so-called "tetra bromodiphenquinone" and the constitution of cerulogline: J. **Moir**.—A note on certain pyrogenic reactions: N. T. M. **Wilmore** and A. W. **Stewart**.

DUBLIN.

Royal Dublin Society, December 17, 1907.—Prof. G. H. Carpenter in the chair.—The separation and quantitative spectra of cerium, lanthanum, and yttrium: Dr. J. H. **Pollak** and A. G. G. **Leonard**.—The quantitative spectra of molybdenum, tungsten, thorium, and zirconium:

A. G. G. **Leonard**. These two papers are in continuation of the authors' joint work on the quantitative spectra of the elements, undertaken to facilitate the use of the spectroscopy in its application to ordinary chemical analysis. A reproduction of the spectrum of each element was given, together with a table of the wave-lengths of the most persistent lines, Greek letters being added to indicate the order of disappearance of the lines as the quantity of the element present diminished. In the first paper an account was given of the method of separating the rare metals of the cerite group.

Royal Irish Academy, November 30, 1907.—Dr. F. A. Tarleton, president, in the chair.—The dynamics of a rigid electron: Prof. A. W. **Conway**. A rigid electrified system of any shape is in general motion. A direct calculation is made in a series of approximations of the resultant force and couple due to the internal electric forces. To the first approximation the motion is formally the same as that of a general body moving in a liquid, to the second the motion is found to be aided by a force proportional to the rate of change of the acceleration and independent of the shape. This leads to the ordinary expression for the radiated energy. The third approximation introduces the "transverse" masses. It is shown that the usual expressions for electromagnetic mass become correct if we neglect powers and differential coefficients of the acceleration beyond the first.

December 9, 1907.—Dr. F. A. Tarleton, president, in the chair.—Presidential address on the relation of mathematics to physical science: Dr. **Tarleton**.

PARIS.

Academy of Sciences, December 30, 1907.—M. H. Bequerel in the chair.—Grafting in plants containing hydrocyanic acid: L. **Guignard**. The question as to whether chemical substances secreted by the plant can pass into the graft, or *vice versa*, has been much contested. The author has grafted a plant producing a hydrocyanic glucoside on to another plant totally free from this compound, and inversely; in neither case was there any transport of the glucoside from the graft or the plant. In the artificial symbiosis produced by grafting, each species preserves its chemical characteristics and its autonomy.—Some examples of a collective reasoning in bees: Gaston **Bonnier**. A description of some interesting experiments proving the discipline and division of labour among bees.—The recent determinations of the volume of the kilogram of water: René **Benoit**. A résumé of the work done at the Bureau international des Poids et Mesures by the method of contact, and methods based on the phenomena of interference. The mean of the whole of the experiments is that a kilogram of pure water, at its maximum density and under a pressure of 760 mm., measures 1.00028 cubic decimetres, with an uncertainty of about two units in the last figure.—Tables of Uranus and Neptune by Le Verrier. Rectification of the analytical theory: some new tables: A. **Gaillet**. The method followed in this re-calculation was that of Le Verrier, making use of the rectified values for the masses and elements of the orbits. A comparison of the calculated and observed positions furnishes no indication of the influence of any possible planet beyond the orbit of Neptune.—The theory of the moon: H. **Andoyer**.—Vectorial differential invariants and the theory of binary forms: E. **Waelisch**.—The decomposition of a number into a sum of eighth powers of integers: Edmond **Maillet**.—The equation $\frac{\partial^2 z}{\partial x^2} = \frac{z}{cy}$: E. **Holmgren**.—The definition of the area of a portion of a curved surface: E. **Cartan**.—Inverse functions of integral functions: Pierre **Boutroux**.—The statics of the deformable line: Eugène and François **Cosserat**.—The variations of the absorption bands of didymium and erbium salts in a magnetic field: Jean **Bequerel**.—The spectrophotometry, viscosimetry, and electric signs of solutions: Charles **Henry**.—The specific heat and molecular field of ferromagnetic substances: Pierre **Weiss**. The hypothesis of the molecular field gives a quantitative explanation of the anomalies of the specific heats of ferromagnetic substances.—The electrolytic reduction of indigo: Henri **Chaumat**. The negative electrode

of an electrolytic cell divided by a diaphragm and containing sodium carbonate solution is formed of a mixture of indigo and graphite. The reduced indigo is dissolved by the caustic soda formed in the electrolysis, and 30 per cent. to 40 per cent. of the current is utilised.—Some thermochemical data relating to the chlorine compounds derived from Millon's base: H. **Gaudechon**.—A new method for the hydration of pinene: Ph. **Barbier** and V. **Grignard**. Pinene dissolved in acetic acid is treated with 50 per cent. aqueous solution of benzenesulphonic acid at the ordinary temperature. Terpinol can be isolated from the products of the reaction with a yield of about one-third of the weight of the pinene taken.—The ketone derived from β -hexahydrocarvacrol: Léon **Brunel**.—Two modes of individualisation of albite in the microgranitic *massif* of Genis: Jacques **de Lapparent**.—A general method of microchemical research and its application to the study of the distribution of the saponines in plants: R. **Combes**. The method is based on the formation of an insoluble compound of the saponine with baryta, followed by treatment with potassium bichromate. Each cell in which saponine has been present is stained with barium chromate.—Tea from French colonies: J. **Dybowski**. Teas from Indo-China, compared with Ceylon teas, have a slightly higher proportion of caffeine, and about half the quantity of tannin.—The adaptation of *Orchitophyrea stellarum*, a parasite of the testicles of the star-fish, to a marine medium: Casimir **Cépède**.—Ethyl chloride in the blood during anaesthesia: Lucien **Camus** and Maurice **Nicloux**. Ethyl chloride penetrates into the blood with great rapidity, and its proportion may, under certain conditions, be raised considerably without danger to the organism.—Discontinuous tetanisation: N. **Wedensky**.—Maps showing the distribution of oysters on the coasts of Vendée: M. **Guerin**.

DIARY OF SOCIETIES.

THURSDAY, JANUARY 9.

INSTITUTION OF ELECTRICAL ENGINEERS, at 8.—Cost of Electrical Power for Industrial Purposes: J. F. C. Snell.
MATHEMATICAL SOCIETY, at 5.30.—A Formula in Interpolation: C. S. Jackson.

FRIDAY, JANUARY 10.

ROYAL ASTRONOMICAL SOCIETY, at 5.—Photographs of Comet *d* 1977 (Daniel): Max Wolf.—(1) Note on the Comparative Eccentricities of Visual and Spectroscopic Binary Stars; (2) On the Orbits of β Bootis (2 1889); β 80; β 513—24 Cassiopeie; β 532—11 Orionis; and β 524—20 Persei: T. J. J. See.—Note on the Simple Equation which comprises the Theory of the Fundamental Instruments of the Observatory: Sir R. S. Ball.—Ephemers of Flora near the Time of Opposition in 1908: A. M. W. Downing.—(1) Occultations of Stars by the Moon, observed in the Year 1907; (2) Observations of Saturn's Ninth Satellite, Phoebe, from Photographs taken with the 20-inch Reflector in 1907: Royal Observatory, Greenwich.—On an Improved Illumination of the Field in a Transit Instrument, and its Effects on the Discordance in Reversed Positions of the Instrument: Sir W. H. M. Christie and H. A. H. Christie.—The Perturbations of Halley's Comet in the Past. Second Paper: The Apparatus of 1222: P. H. Cowell and A. C. D. Crommelin.—*Probable Papers*: Proper Motions of Faint Stars in the Pleiades: F. J. M. Stratton.

INSTITUTION OF CIVIL ENGINEERS, at 8.—The Principles of Engineering Geology: Dr. Herbert Lapworth.

MONDAY, JANUARY 13.

ROYAL GEOGRAPHICAL SOCIETY, at 8.30.—Among the Volcanoes of Guatemala and St. Vincent: Dr. Tempest Anderson.

TUESDAY, JANUARY 14.

ROYAL INSTITUTION, at 5.—The Internal Ear of Different Animals: Dr. Albert A. Gray.

ZOOLOGICAL SOCIETY, at 8.30.—Description of a Biological Expedition to Birket el Qubur: Dr. W. A. Cunningham.—The Duke of Bedford's Zoological Exploration in Eastern Asia. VI. List of Mammals from the Shantung Peninsula, N. China: O. Thomas, F.R.S.—On the Musculature and other Points in the Anatomy of the Engystomatid Frog, *Drepanocercus verrucosus*: F. E. Beddard, F.R.S.

INSTITUTION OF CIVIL ENGINEERS, at 8.—Continued discussion: Keyham Dockyard Extension: Sir Whately Elliot.—Keyham Dockyard Extension: Temporary Works, and Plant and Appliances used in Construction: G. H. Scott.

WEDNESDAY, JANUARY 15.

ROYAL METEOROLOGICAL SOCIETY, at 7.30.—Ordinary Meeting.—At 7.45. Annual General Meeting.—Presidential Address on "Map-Studies of Rainfall": Dr. H. R. Mill.

ENTOMOLOGICAL SOCIETY, at 8.—Annual General Meeting.
SOCIETY OF ARTS, at 8.—Screen-Plate Processes of Colour Photography: Dr. C. E. Kenneth Mees.

ROYAL MICROSCOPICAL SOCIETY, at 8.—On the Microscope as an Aid to the Study of the Biology of Insects with Special Reference to the Food:

W. Wesché.—Improved Type of Mercury Vapour Lamp for use with the Microscope: J. E. Barnard.

THURSDAY, JANUARY 16.

ROYAL SOCIETY, at 4.30.—*Probable Papers*: Alternate Current Measurement: Dr. W. E. Sumner.—Prominence and Coronal Structure: Dr. W. J. S. Lockyer.—The Conversion of Diamond into Coke in High Vacuum by Kathode Rays: Hon. C. A. Parsons, C.B., F.R.S., and A. A. Campbell Swinton.—And other Papers.

ROYAL INSTITUTION, at 3.—The Building of Britain: Prof. W. W. Watts, F.R.S.

INSTITUTION OF MINING AND METALLURGY, at 8.

SOCIETY OF ARTS, at 4.30.—Indian Agriculture: Henry S. Lawrence.

LINNEAN SOCIETY, at 8.—(1) Brassica Crosses, illustrated by lantern slides:

(2) Notes on Wild Types of Tuber-bearing Solanums, illustrated by lantern slides: A. W. Sutton.—Revision of the genus *Illigera*, Blume: S. T. Dunn.—New Conifer of Formosa: Bunzō Hayata.

CHEMICAL SOCIETY, at 8.30.—Colour and Constitution of Azo-compounds.

PART II. The Salts of β -Hydroxyazo-compounds with Mineral Acids:

J. J. Fox and J. T. Hewitt.—The Oxidation of Aromatic Hydrazines by Metallic Oxides, Permanganates, and Chromates: F. D. Chattaway.

—Studies in Fermentation. II. The Mechanism of Alcoholic Fermentation:

A. Slator.—Organic Derivatives of Silicon. Part IV. The Sulphonation of Benzylhydropropylsilyl Oxide and of Benzylhydropropyl-

Silicane: H. Marsden and F. S. Kipping.—The Formation and Reactions of Imino-compounds. Part VI. The Formation of Derivatives

of Hydrindene from α -Xylylenedinitrile: J. W. Moore and J. F. Thorpe.

FRIDAY, JANUARY 17.

ROYAL INSTITUTION, at 9.—The Centenary of Davy's Discovery of the

Metals of the Alkali: Prof. T. E. Thorpe, C.B., F.R.S.

INSTITUTION OF MECHANICAL ENGINEERS, at 8.—Third Report to the

Gas-Engine Research Committee: Prof. F. W. Burstell.

INSTITUTION OF CIVIL ENGINEERS, at 8.—The Principles of Engineering

Geology: Dr. Herbert Lapworth.

SATURDAY, JANUARY 18.

ROYAL INSTITUTION, at 3.—The Electrification of Railways: Prof. Gisbert

Kapp.

CONTENTS.

	PAGE
The History of Aeronautics.	217
Treatment of Home-Woods	217
Water Supply	218
Veterinary Physiology. By Dr. Percy T. Hering.	219
Our Book Shelf:—	
Clark: "The Polarity of Matter"	219
Saunders: "With Bees, Wasps and Ants, and other Stinging Insects"	220
Barkhausen: "Das Problem der Schwingungserzeugung"—H. B.	220
Gould: "Album de Aves Amazonicas"	220
Letters to the Editor:—	
A Specific Gravity Balance for Large Rock Specimens. (<i>With Diagram</i>).—T. H. D. La Touche	221
A Point in the Mathematical Theory of Elasticity.—Prof. E. Brown	221
Echelon Spectroscopy.—H. Stansfield	222
The Photoelectric Property of Selenium.—Prof. George M. Minchin, F.R.S.	222
Musical Sands.—Cecil Carius-Wilson	222
Sport and Natural History. (<i>Illustrated</i>). By R. L. "Kimberlite" and the Source of the Diamond in South Africa. By Dr. F. H. Hatch	223
The Induction of Anæsthesia by Chloroform	226
Archæological Remains in Wales and the Marches	227
Dr. P. J. C. Janssen	239
Notes	230
Our Astronomical Column:—	
Return of Encke's Comet (1908a)	234
Saturn's Rings	234
The Spectra of Two Meteors	234
The Constancy of Wave-lengths of Spectral Lines	234
New Chemical Laboratories at Aberystwyth. (<i>Illustrated</i>)	234
Scientific Work of the Local Government Board. By Prof. R. T. Hewlett	235
Mendelism and Sex. By G. Archdall Reid	236
University and Educational Intelligence	237
Societies and Academic Notes	238
Diary of Societies	240

THURSDAY, JANUARY 16, 1908

THE COTTON PLANT.

The Wild and Cultivated Cotton Plants of the World. A Revision of the Genus Gossypium. By Sir G. Watt. Pp. xiv + 406. (London: Longmans, Green and Co., 1907.) Price 30s. net.

SINCE the appearance, in 1877-8, of Todaro's classic monograph on the genus *Gossypium*, no serious attempt has been made to deal systematically with the botany of the plants that provide the world's supply of cotton. Todaro's work—at once the first and last of any practical utility—owes its value to the fact that he worked for the most part with living plants grown by him from seed received from many parts of the world; the success this method met with justifies the dictum of De Candolle in his "Prodromus" when, speaking of this genus, he says, "Hic species a Botanicis admissas reenseam, monens tamen hoc genus monographiæ accuratæ et ex vivo elaboratæ maxime egerè." (The italics are not in the original.) Todaro's work requires only to be continued and extended, not to be corrected.

Any attempt at a classification of cotton plants that is based on herbarium specimens is doomed to failure owing to the impossibility of eliminating the effects that differences of soil and rainfall have in inducing differences of appearance in the leaves and other parts of specimens of the same variety that are *not grown under identical conditions*. Many varieties of the genus, even under the most uniform conditions of growth, show a sufficiently wide range of fluctuations to necessitate great care in their determination even when living plants are being examined; when we work on dried specimens, often very fragmentary, grown in widely distant parts of the world under conditions of rainfall that are not recorded, imaginary differentiations occur to such an extent as to make it impossible to deduce a classification of the varieties that more than indicates broadly the groups into which they fall; to attempt anything more than this with herbarium material is to court failure.

The latest attempt at a monograph of the genus *Gossypium* is the volume now under review. This, unfortunately, belongs to the category for which success is an impossibility, being based entirely—except possibly in the case of a few Indian forms—on herbarium specimens.

The volume contains some most interesting photographic reproductions of a few type-specimens in the Kew, British Museum and Linnean herbaria, and also (often in colours) of early drawings of plants. These reproductions form by far the most valuable portion of the work.

It is impossible in the space at our disposal to give even a general impression of the contents of the volume, much less to point out in detail the very numerous errors into which the herbarium method has led its author. No new information is given us, though several new species and more varieties are created on imaginary differentiations, while nearly

every variety that has hitherto been described and named receives a new name.

Thus, of the forty-two varieties mentioned in the volume, Nos. 10 to 25 are cultivated Asiatic or African forms, and out of these sixteen varieties, classified as belonging to four species, all except the species themselves receive new names unnecessarily. When we state that many of the synonyms given fail under investigation, and that the descriptions of plants stated to belong to particular species often differ radically from the descriptions given by the authors of the species, it can well be imagined that the volume is rather a retrogression than an advance on the work of Todaro.

Throughout the book the reader is allowed no opportunity of judging of the correctness of the identification given, since the original definition of the variety is practically never quoted, and must be looked for in the very scattered literature on the genus. It would also have been fairer if, in the case of species here created, a photographic reproduction of the type had been given, and not merely outline drawings, which, throughout the volume, are not good and would not assist in the identification of the plants in the field.

As an example of erroneous synonymy we may take the following case:—

G. obtusifolium, Roxb., var. *Wightiana*, Watt, is stated to be synonymous with *G. Wightianum*, Tod., and to be the plant constituting the Surtee-Broach growth of India. Now, all botanical considerations apart, Todaro states that the seed that gave rise to his *G. Wightianum* was as follows:—"Cotone Hingunghatt di Bombay," "Oomrawatt di Bombay," "Howers Barree (*sic*) di Bombay," "Khandeish (*sic*) from American seed di Bombay," "Cotone Hingunghatt Barree (*sic*)," and "Old Dhollera, provenienza di Bombay." Now, in none of the places mentioned—Hingunghatt, Oomrawati, Barsee, Khandeish, Dhollera—will the Surtee-Broach plant grow except in Dhollera; and, curiously enough, Todaro mentions that another sample of Dhollera seed received *directly* from Bombay gave rise to plants belonging not to the species *Wightianum*, but to the species *herbaceum*, and giving "un prodotto di bellissima qualità."

Todaro having 'already' placed the Surtee-Broach plant in the species *herbaceum*, it would appear unnecessary that, as in the volume before us, it should be removed into the species *obtusifolium*, to which it is certainly, to say the least, not more closely related. This removal is further objectionable owing to the great uncertainty as to what plant Roxburgh intended to indicate by the latter name. On this point, again, our author is at once confused and confusing; he states (p. 140) that *G. obtusifolium*, Roxb., is "fairly common in the hedges of Gujarat," while (p. 135) *G. nanking*, var. *roji*, is also said to become sub-scandent in hedgerows in the same district. The present writer has collected and sown in Gujarat many samples of seed from these hedgerow cottons, and the resulting plants have invariably been identical with one another, and also with the crop known as "roji," which our author classifies as *G. nanking*, Meyer,

var. *roji*, Watt. It can safely be said that the last varietal name is superfluous, being synonymous with *G. obtusifolium*, Roxb., as interpreted in this book.

As examples of cases in which a plant is wrongly assigned to an old-established species, the following cases may be cited:—

(1) *G. peruvianum*, Cav., is stated (p. 217) to have fuzz-coated seeds, though Cavanilles states that the seeds are black, i.e. devoid of fuzz, and figures them so. This discrepancy would have been immaterial had not the presence or absence of fuzz on the seed been made the basis of classification (see later). This plant is stated to produce the Imbabura cotton of Peru, while the Piura cotton is stated to be produced by a somewhat similar but hairy plant, which is identified as *G. vitifolium*, Lamk. It suffices to say first that Piura cotton is produced by the plant Cavanilles called *peruvianum*, which has, as that author states, naked seeds; and secondly, that Lamarck states that his species *vitifolium* has the under sides of its leaves glabrous.

(2) Of *G. microcarpum*, Tod., its author mentions specially that the two lobes on either side of the central one were unequal, and gives a good figure of this. Our present author not only gives (plate 36) a plant with much broader lobes, but one which does not display the peculiarity of lobes mentioned, is called "red Peruvian cotton," and differs from ordinary Peruvian only in bearing brown cotton instead of white. The reviewer has grown the real *G. microcarpum*, which is an exceedingly characteristic variety, and can be distinguished with certainty at a glance. It is, indeed, the plant for which our author has created a new species, viz., *G. Schottii*, two specimens cited as types in the British Museum being exactly the plant as figured and described by Tcdaro, and as grown by the present writer. Examples of this kind might be multiplied almost indefinitely.

Turning to the system on which the varieties are classified in the volume under review, we find it is as follows:—

Section i., Species with fuzz but no floss.

Section ii., Fuzzy seeded cottons with united bracteoles.

Section iii., Fuzzy seeded cottons with free bracteoles.

Section iv., Naked seeded cottons with bracteoles free, or nearly so, and glands conspicuous.

Section v., Naked seeded cottons with bracteoles quite free and floral glands absent.

It will be noted that the presence or otherwise of a fuzzy covering to the seed below the cotton is made the primary basis of classification. Now it is hardly too much to say that every cultivated species of cotton comprises varieties some of which bear a fuzzy and others do not. The present writer has found among others completely naked seeded varieties in the species (to adopt the nomenclature of our author) *G. nanking* (Chinese and Japanese cottons), *G. nanking*, var. *roji*, *G. obtusifolium*, var. *Wightiana*, *G. herbaceum*, *G. punctatum*, *G. hirsutum*. The naked-seeded varieties show not the slightest trace of hybridisation with a member of sections iv. or v.,

and, indeed, a hybrid between any of the first four varieties named and a member of sections iv. and v. is by no means readily produced even by artificial means. Yet our author seeks to explain the occurrence of naked seeds in the "jowari hathi" (=country cotton) of Madras by the supposition of a naturally produced cross between *G. obtusifolium*, var. *Wightiana* (section ii.), and Bourbon cotton (*G. purpurascens*, section iv.). Similarly, those of American upland varieties that have naked seeds are said to be crosses with a naked-seeded variety for this reason alone.

If any further proof of the fallacy of this method is required, it is found in the fact that fuzzy-seeded American has in India been converted into a naked-seeded variety in a few generations by the present writer through the simple process of growing it under irrigation in well-manured soil. That such a change occurs is well known to cultivators in the West Indies and other parts of the world.

If we take the second point on which the classification is based, viz. whether the bracteoles are free or united, we find the same impossibility of applying the characteristic in the field, in some varieties there being found, on the same plant, flowers with the bracteoles all free, others with them all united, and still others with two united and one free.

The last chapter (thirty-one pages) is devoted to a discussion of "The Improvement of the Cotton Plant." This consists merely of a general description of the process of selection equally applicable to all crops, an attempt to trace the history of some varieties now grown, and a description of the pollen grains of some species of cotton.

Throughout the book no attempt is made to give the character of the cotton produced under given conditions of soil and climate by the several varieties described, though the author hopes in his preface that the book will be useful to "planters and seed producers throughout the world."

F. FLETCHER.

A CONCISE WORK ON EVOLUTION.

Evolution and Animal Life. An Elementary Discussion of Facts, Processes, Laws and Theories relating to the Life and Evolution of Animals. By David Starr Jordan and Vernon Lyman Kellogg. Pp. xi+489; illustrated. (New York: D. Appleton and Company, 1907.) Price 2.50 dollars net.

THERE is growing up a generation of biological students that does not read its Darwin, its Weismann, or Galton; instead, it cons manuals and text-books on the works of these masters. It is so very much less trouble, if the student's object is to satisfy an examiner, to "get up" a text-book on evolutionary problems than to extract from original sources a clear conception of the authors' theories; and yet what a world of difference is there between the *ipsisima verba* of a master and the cut-and-dried phrases of the manual-maker! The one is the advocate pleading his cause with all the eloquence in his power, the other the reporter compressing the living words and phrases into the limits of a column. The

one is inspiring, stimulating, the other can scarcely avoid exceeding dullness, and certainly no one ever yet was roused to enthusiasm by a text-book.

The book before us is no worse than most of its kind; indeed, it is a great deal better than many. It is compiled from lectures delivered at the Leland Stanford Junior University, and traces of the originality which must have characterised the lectures of two zoologists of the standing of our authors may be found in the book. Refreshing oases of excerpts from original sources frequently add variety to arid plains of didactic statement, and occasionally one may stumble on a good story; such as that of the frozen fish which, bolted whole by a ravenous dog, later emerged alive and flapping from its prison; or the comment of Yves Delage on Schaffhausen's statement that life must have originated from simple inorganic substances, and taken the form of an uncoloured protococcus which later became *Protococcus viridis*. "If the thing is so simple, why does not the author produce one of these protococci in his laboratory? *On lui ferait grace de la chlorophylle.*"

There is a wealth of process-block illustrations of varying degrees of excellence; some are new, some emerge from the obscurity of scientific journals, and some old friends do duty once again. Frequently there is no reference in the text to the figures, and the intelligent student will ask himself for what purpose they are there. As an example may be taken a very poor figure on p. 306, in the chapter on paleontology; it is entitled "Flying Dragon (Draco)." What is this meant to teach our intelligent student? For all that he may find out from the text it may be a mythical monster, the restoration of some giant fossil form, or the little flying lizard of the Oriental tropics.

The ground covered in this work is immense, as the titles of some of the chapters indicate:—Variation and Mutation, Generation, Sex and Ontogeny, Geographical Distribution, Parasitism and Degeneration, Reflexes, Instinct and Reason. The bearing of paleontology on problems of evolution is discussed in eighteen pages; man's place in nature in seventeen. It is impossible to criticise such penmanship at any length; if it is inaccurate it is worthless; if accurate it is of some value. With few exceptions the accuracy of the authors cannot be called in question; we would, however, protest against the view advanced that, whilst variations in the external organs of ametabolic insects may be due to the influence of environment, the variations of corresponding structures in holometabolic insects are congenital. To use the post-embryonic development of a structure as a criterion whereby to judge the nature of its variation is most unsound, for it is not justified by the results of experiments. So that to state (p. 145), "The variations in the colour pattern of *Diabrotica*, *Hippodamia* and *Vespa* are congenital variations" is, to put it mildly, misleading.

The authors, it is evident, are not supporters of the theory of sexual selection, and all the familiar objections to it are paraded. In this connection it is interesting to read the recently published papers by Mr. Edmund Selous on the courtship of birds; the papers are so admirable that they should be consulted by

everyone interested in the subject, but it is difficult to refrain from quoting the concluding words of the gifted author.

"I would urge that the facts here brought forward by me, in regard to four different species of birds, are, both singly and cumulatively, strongly in support of Darwin's second great hypothesis of sexual selection, and I believe that, as denial from the chair is replaced or supplemented by evidence from the field, the views of that great naturalist and reasoner will be triumphantly and often most strikingly vindicated."

The insects shown in Fig. 251 are not Membracidae or leaf-hoppers of the order Hemiptera, but Acrididae or grasshoppers of the order Orthoptera. Schaudinn is misspelt Schaudin, and Chillingham Chellenham; there are also one or two obvious misprints. The names of some of the animals quoted are strangely unfamiliar. One might ask the nature of a piddock, a cusk, a silverside, a killifish if the Latin equivalents were not also given, and once again we have occasion to bless the name of Linnæus.

R. S.

STUDIES IN EDUCATION.

The Practice of Instruction. Edited by Prof. J. W. Adamson. Pp. xxi+512. (London: The National Society's Depository, n.d.) Price 4s. 6d. net.

IT has been a favourite plan with English publishers to issue a text-book on teaching made up of separate essays on the teaching of various subjects, with an introduction on general principles of education written by the editor. Mr. P. A. Barnett's "Teaching and Organisation" was the first in the field, and now Prof. Adamson has prepared a similar volume for the National Society.

We confess that we somewhat distrust this method of putting a book together. It is difficult to secure cohesion; some of the essays are pretty certain to disappoint the editor, and such a book can very seldom be adopted for regular use by a body of students. In the volume before us one-third is contributed by the editor, and he provides a really able introduction to the psychology of the schoolroom; there are omissions which betray the author's lack of sympathy with the more practical needs of the young, but within the prescribed limits Prof. Adamson is helpful and clear, and a section devoted to experiments in curriculum and method shows that he is both alive to what is being done at home and abroad, and that he is in sympathy with cautious educational reform.

The rest, two-thirds of the volume, is distributed among ten writers, and some of the essays are of most excellent quality; but Principal Headlam on religious instruction, and Miss Howard on history, are weak performances. Dr. Herbertson's essay on geography contains the views with which the Geographical Association has made us familiar, but it is very evident that much of the work which he prescribes for children has never been taught by himself, and an air of unreality pervades his proposals. In these three sections we feel sure that the editor would have done better to have worked up

the exposition himself, for his introduction shows that he has a good acquaintance both with the capacities of children and with the way in which these studies may be utilised to serve the ends of mental development. Neither Miss Howard nor Dr. Herbertson seem to have got much beyond the primitive idea that children possess empty knowledge boxes into which geographical and historical information can be shot at will.

The other sections are on a higher level. Mr. Baker's account of mathematics is quite good, and will be helpful to teachers in any type of school; but his treatment suffers from compression, for it is impossible to cover in the space allotted the whole field of study from the infant stage to the commencement of trigonometry. Natural science fares well in the hands of Dr. Percy Nunn and Miss von Wyss, and any teacher of science, especially in secondary schools or technical institutions, will profit from studying with care their exposition of method. In their selection of sciences for the "intermediate" and "final" stages we are inclined to think the writers take too narrow a view; botany, chemistry, and physics have their place, but many would prefer, especially in view of the increasing claims of hygiene, to see more recognition given to physiology in the year or two preceding the scholar's departure from school. Languages have been placed in the hands of Dr. Rouse (aided by his colleague, Mr. W. H. S. Jones) for Latin and Greek, and Mr. Mansfield Poole for French and German. Both belong to the ranks of avowed "reformers." Many schoolmasters will rub their eyes with blank amazement on reading the specimen lessons in Greek dialogue as conducted in the Perse Grammar School, but Dr. Rouse's system is merely the application of the same general principles which Mr. Poole expounds for a modern language.

On closing the book one is encouraged to recognise the progress that English teachers are making in the serious study of professional work. Ten years have elapsed since Mr. Barnett edited the pioneer volume of this description, and the comparison is favourable to the craftsman schoolmaster of the present day.

MAINTENANCE OF ROADS.

Road-making and Maintenance. A Practical Treatise for Engineers, Surveyors, and Others. By Thomas Aitken. Second edition. Pp. xviii+527; illustrated. (London: Charles Griffin and Co., Ltd.) Price 21s. net.

THE first edition of this book was published in 1901, and the fact that a second edition of a technical book of this character should be called for within so short a period testifies to its value, and also to the greater attention that has been given to the maintenance of roads within the last few years.

After the advent of railways, and the abolition of turnpikes, road-making became a very neglected science; the advent of bicycles and the inconvenience felt by a very large section of the public caused pressure to be brought on highway authorities, and a gradual improvement set in. The subsequent intro-

duction of motor-cars brought road maintenance very much to the front, and, taken generally, the main roads of this country are now kept in very fair condition. This, however, has involved a very large expenditure. It was stated at a recent discussion on motor vehicles at the Institution of Civil Engineers by the surveyor of the county of Middlesex that the cost of main roads in his county had increased from 49,000*l.* in 1880 to 90,391*l.* in 1905. In the two years 1904-6 improvements on the roads had amounted to 86,536*l.* The cost of the main roads of England and Wales has increased from 2,120,332*l.* in 1901 to 2,478,481*l.* in 1905.

The book now under notice has been revised and brought up to date, and much new matter has been added. The question of damage done to the roads by motor-cars, and the nuisance arising from dust caused by the speed at which these vehicles are driven, has been fully treated in a new chapter. A description of the various remedies that have been tried for dealing with the dust problem is given. The conclusion at which the author has arrived is that no real solution for dealing with this nuisance has yet been found, but he has no doubt that the system of "tar macadam" or "building up the road stone coating with a matrix of tar, chips and dust as a binding medium is the best possible method of solving the dust problem in a satisfactory and permanent manner."

The advantages of tar macadam are increased durability over ordinary macadam, imperviousness to moisture, capability of being kept clean, and the surface is not liable to be disintegrated by frost. Owing to its greater durability and to the fact that the surface of the road can be renewed by a thin coating of fine tar macadam, from time to time, without disturbing the subsurface or foundations, the cost over a series of years, when everything is taken into consideration, is not more than that of a steam-rolled ordinary macadam road. The author of this book, however, expresses the opinion that its first cost prohibits its adoption on an extensive scale on rural main roads.

The book is divided into eighteen chapters, dealing in an exhaustive and practical manner with the following subjects:—Historical sketch of road-making; resistance to traction on roads; laying out new roads and the improvement of those already made; retaining walls, culverts, bridges, &c.; materials used for repairs; quarrying road stone; breaking and haulage; rolling and scarifying; prevention of dust; footways; wood pavement; asphalt; brick pavement; tar macadam; testing the surface of roads and use of the viagraph; subways.

OUR BOOK SHELF.

A History of Chemistry. By Hugo Bauer. Translated by R. V. Stanford. Pp. vii+232. (London: Edward Arnold, 1907.) Price 3s. 6d. net.

The philosophy of chemistry can only be properly studied by the historical method. Present-day chemical philosophy, like present-day religion, is a product of evolution, and to understand it thoroughly it is necessary to be able to trace the successive stages

by which past beliefs have become merged into present doctrine. Hence the increased attention which is now paid to the history of chemistry, and especially to the history of the development of chemical theory; and hence, too, the large increase in the number of works dealing with the historical aspects of chemistry which have appeared within recent years.

Dr. Bauer's little book cannot be considered as an important addition to the list. To tell the story adequately of the origin and growth of chemistry from the earliest times down to this age of ions and electrons is hardly possible within the limits of 220 small octavo pages. The book, however, may serve to whet the student's appetite for a fuller acquaintance with the subject, although in reading it he will have something to unlearn. To accuse Priestley of "personal intolerance" (p. 69) is wholly to misjudge his character, and the translator—a Priestley research scholar in the University of Birmingham—should have been more careful of what was due to his memory. To say, too, that Cavendish "contended against Lavoisier's theory of combustion until his death" is hardly consistent with accuracy. Cavendish never "contended" against anything; "contention" was absolutely foreign to his disposition, and, as a matter of fact, he ceased to take interest in chemical subjects long before his death. Nizza, as the place of his birth, may stand in the original German, but the English reader is more familiar with it as "Nice." John Dalton is said to have led (probably from his hard up-bringing) "a very modest life," and to have "died at Geneva in 1829." If this is a faithful rendering we must suppose that Dr. Bauer got his notes into confusion, since Dalton died at Manchester in 1844. The date and place evidently refer to Humphry Davy, of whom, however, no biographical account is given. To come down to later times, Kekulé is said to have become professor of chemistry at Geneva in 1858; for Geneva read Ghent. Ultramarine is not usually classed as a dye-stuff. Thallium was not discovered by Mosander in the earth from Ytterby, as stated on p. 189; nor was fluorine isolated by Moissan by the aid of the electric furnace (p. 216). The name of Lord Rayleigh is not usually associated with the discovery of helium, xenon, krypton, and neon (p. 217), nor did M. and Mme. Curie isolate radium from "natural pitchblende" as the bromide.

Boyle, we are told, "left many writings, which give us pleasure by their simple style and clearness of expression." Whatever may be the merit of Boyle's writings, their style is hardly that of Addison, and probably no man living has had the courage and tenacity to work through them. Dr. Bauer is evidently not familiar with Swift's "Pious Meditation on a Broomstick in the Style of the Honourable Mr. Boyle."

In spite of minor blemishes the book is not without merit; indeed, it is eminently readable, and interesting. But it needs careful revision, since in its present form a judicious teacher could hardly commend it to his pupils.

Neolithic Dew-ponds and Cattle-ways. By Dr. Arthur John Hubbard and George Hubbard. Second edition. Pp. xxiv+116; illustrated. (London: Longmans, Green and Co., 1907.) Price 4s. 6d. net.

This interesting work has been considerably enlarged since the appearance of the first edition (1905), which was reviewed in NATURE for April 27, 1905 (p. 611, No. 1852). The older work, with its convincing argument of Neolithic man fortifying the heights in order to escape the ravages made by the wolves of the plains on his flocks, has been retained and added to,

and we also find the astronomical significance of some ancient works discussed.

In chapter ii. the authors state that they have found the orientation of Maumbury Rings, near Dorchester, to coincide accurately with that of Stonehenge; it would be of great interest to have the exact azimuth of the axis, and also the angular height of the horizon over which the sun is supposed to have risen, in order that the solstitial evidence could be more rigorously tested. Should this prove a true case, the discussion of the data would probably give us an earlier date than the 1680 B.C. \pm 200 years (not 1800 B.C. \pm 200 years, as stated by Messrs. Hubbard) found by Sir Norman Lockyer and Mr. Penrose for the more imposing structure on Salisbury Plain. One of the added chapters (vii.) discusses the possible astronomical origin of some earthworks on the top of Firdle Down, in Sussex, and the authors tentatively suggest that they were probably constructed about 1900 B.C. for the purpose of observing the critical seasons of the May and solstitial years. But the evidence needs very careful sifting before one may fix a solstitial date, as was shown in the above-mentioned investigation of the much more permanent stone structure at Stonehenge. Denudation, subaerial, human and animal, will probably have played havoc with earthwork alignments, and the fixing of the original lines, it seems to us, must be more or less an arbitrary proceeding. We would point out that the straight line G.O.B. on the plan given on p. 99 could not possibly indicate the rising and the setting points of the May sun, as stated in the notes; probably the authors mean the rising of the November sun of the May year, for which the azimuth S. 62° E. would be approximately correct.

The book is beautifully printed and illustrated with reproductions from photographs, and should do a great deal to increase the general interest now being taken in the ancient monuments of these islands.

W. E. ROLSTON.

Übungsbeispiele aus der anorganischen Experimentalmchemie. By Heinrich Biltz und Wilhelm Biltz. Pp. xi+232. (Leipzig: Wilhelm Engelmann, 1907.) Price 7 marks.

THERE are many books devoted to the preparation of organic compounds, but one rarely comes across one written especially for the study of inorganic preparatory work. It seems to be imagined that great skill is required to prepare organic compounds, but that anyone can prepare inorganic compounds in a state of purity and with good yields without any previous study. As a matter of fact, the preparation of pure inorganic compounds is by no means simple, and it is a great pity that this branch of chemistry is very rarely taught in a systematic manner. Consequently almost all the research carried out in this country is along organic lines, because owing to the interest aroused by the preparation of organic compounds, the student naturally turns to organic chemistry.

The book before us deals in the main with inorganic preparations, and is arranged, so far as possible, upon systematic lines. Thus chapter i. deals with reductions of oxides, by means of carbon, aluminium, potassium cyanide, and other reducing agents. The sequence mercury from cinnabar and then sodium and ammonium amalgam is rather strange, as some would expect the amalgams to be treated of in connection with alloys. Chapter ii. treats of polymerisation and dissociation, for example, the allotropy of silver sulphide, the modifications of sulphur, the passive state of iron, colloidal solutions, and so on. Then follows the preparation of various

oxides and hydrides, acids, bases and salts, halogen compounds and sulphides.

The preparation of the nitrides of calcium and boron strikes us as strange. The calcium or boron are heated in the air, and so one obtains a mixture of oxide and nitride. As, however, the oxide and nitride cannot be separated, there seems very little point in the experiment, except that the student's attention is directed to ammonia from the air. Certainly, but if the air is first passed over red-hot copper, thus freed from oxygen, and subsequently passed over the heated calcium or boron, surely the experiment is much more striking, and, further, the pure nitride is prepared. This method of preparation would also lead up to a discussion of argon and similar gases.

The book will undoubtedly be of great use to teachers of inorganic chemistry and others who wish to study the subject from a preparatory point of view, but it is rather too full for the average student, who would certainly require very careful direction, or he would be inclined to wander along in a rather aimless fashion.

F. M. P.

The Bacteriological Examination of Disinfectants. By William Partridge. With a preface by Major C. E. P. Fowler. Pp. 66. (London: The Sanitary Publishing Co., Ltd., 1907.) Price 2s. 6d. net.

The subject of disinfectants has lately attracted considerable attention, and Mr. Partridge's little book forms a very useful summary of the methods employed for testing bacteriologically the germicidal value of disinfectants. The Rideal-Walker or "drop" method is rightly that most favoured, and the major part of the book is devoted to it. We doubt if the explanation given on p. 17, that a forty-eight hours' culture of *B. typhosus* is less readily killed by a disinfectant than a twenty-four hours' one, because it is more vigorous, is correct; we should ascribe the fact rather to the greater number of bacilli and to clumping in the older culture. On p. 18 it is said that while a broth having a reaction of +1.5 is suitable for the culture of the typhoid bacillus, for the diphtheria and cholera organisms a "neutral or alkaline broth must be substituted." The broth named is quite suitable for these organisms, for it is alkaline in the ordinary acceptance of the term; though acid to phenolphthalein, it is still alkaline to litmus. On p. 34 an experiment is quoted to show that an organism from different sources may have a different resisting power from a disinfectant. Doubtless this is so, but the experiment does not prove it. The experiment shows that two strains of the typhoid bacillus, with strengths of carbolic of 1 in 70 and 1 in 100 respectively, are killed in between 5 and 7½ minutes; obviously the one might have been killed in 5½ minutes, the other in 7¼ minutes, and actually there might have been little difference between them. Everyone has his own method of manipulating tubes for inoculation, but we do not like either method depicted in Figs. 3 and 4. Major Fowler, R.A.M.C., contributes a useful introduction.

R. T. HEWLETT.

Ergebnisse und Fortschritte der Zoologie. Edited by Dr. J. W. Spengel. Vol. i., part 1. (Jena: Gustav Fischer.)

UNDER the above title Mr. Gustav Fischer is issuing a new zoological journal, of which a variable number of parts are to appear each year, the whole to form an annual volume at the price of sixty marks. As no prospectus is issued with the part now before us, we are unable to indicate the ground which the publication is specially intended to cover. The present part contains 238 somewhat closely printed 8vo pages, illustrated by fifty text-figures; and from this we presume that plates do not enter into the scheme of the new

venture. The name of the editor is a sufficient guarantee that only papers of a high order will be accepted for publication, this being fully borne out by the contents of the initial number. These comprise a discussion on chromosomes by Mr. Valentin Häcker, of Stuttgart; an article by Dr. Richard Heymons on the various types of insect metamorphosis, and their relation to the metamorphoses of other arthropods; and another, by Mr. O. Maas, of Munich, on the scyphomedusæ. The new enterprise has our best wishes for success.

R. L.

LETTERS TO THE EDITOR.

[The Editor does not hold himself responsible for opinions expressed by his correspondents. Neither can he undertake to return, or to correspond with the writers of, rejected manuscripts intended for this or any other part of NATURE. No notice is taken of anonymous communications.]

Seismographs and Seismograms.

As I have had occasion to study and compare the records of nearly all the types of seismographs for recording distant earthquakes which are now in use, I may perhaps be permitted to add something to Prof. Milne's letter in NATURE of January 2. The nature of the records, and the relative merits of different types, of seismographs, are not generally apprehended in England, and appear to be misunderstood in Strassburg, from whence much of the recent seismological literature has been inspired.

The two leading problems of seismology, as it stands at present, are the determination, *firstly*, of the exact nature and amount of the movement which takes place, and, *secondly*, of the time requisite for the transmission of the different types of disturbance from the origin, to various distances, and in various directions, through the earth, or along its surface. The first of these is naturally the special object of purely seismological stations and observatories, and for it no single instrument or type of instrument will be sufficient. From the mathematical and experimental investigations of the mechanics of seismographs by Prince Galitzin, Prof. Rudzki and others, it has been conclusively established that no form of instrument, having a pendular period of vibration of its own, however perfectly the oscillations may be damped, can possibly record with exactitude an undulatory movement of the soil such as is caused by earthquakes. As every instrument giving a continuous record must necessarily be of the nature of a pendulum of some sort or other, owing to the necessity for bringing the recording point back to the zero line of the record, it is obvious that no single instrument can suffice for this purpose, and that the only way, by which an understanding of the nature of the movement of the soil can be arrived at, is by installing a number of instruments, of different types and varying response to movements in diverse directions and of unlike period.

For the second purpose a totally different set of conditions comes in. It is no longer necessary to attempt an exact, or even an approximate, representation of the actual movement of the ground, so long as the instruments give records in which the different phases of wave motion can be recognised with reasonable certainty; but, since the solution of this problem involves the collection of numerous records from many stations, it is necessary to obtain the cooperation of astronomical, physical, meteorological, and other observatories, and, consequently, certain conditions, which may be ignored in a specially seismological station, have to be taken into consideration. These are:—

- (1) The instrument must not be unduly cumbersome or bulky; it must be easy of transport, occupy only a moderate floor space, and not require special and expensive foundations.
- (2) It must run without much attention, and at as moderate a cost as possible.
- (3) It must be sufficiently sensitive and consistent in its action to give records capable of interpretation as a general

ruler—no instrument has yet been devised which will invariably do this—but should not be too sensitive, or the record of important disturbances may be lost.

(4) The records should be capable of easy and rapid reproduction.

Of the instruments which have been designed or suggested for this purpose, four types are in use to a greater or less extent.

The Wiechert so-called astatic pendulum is an inverted pendulum with a bob weighing more than a ton, kept in position by two springs, and provided with an ingenious system of air-damping of its vibrations. This instrument has been recommended for general use, because its supposed astatic nature is believed to make it record the movement of the soil in an accurate manner; as already pointed out, this condition is immaterial, and, moreover, cannot be completely fulfilled. The instrument is undoubtedly a fine one, and gives valuable records, but its proper place is in an observatory specially devoted to seismology; for general use it is too heavy, requires too much attention, and gives records which are not adapted for ready and rapid reproduction.

The Rebeur-Ehrlert instrument is a horizontal pendulum, of the form devised by v. Rebeur-Paschwitz, combined with a recording arrangement devised by Prof. Ehrlert. This instrument is an extremely sensitive one, and there seems to be none better for recording small disturbances; in the case of large earthquakes the record is apt to be lost. The record is photographic, and the seismograms are readily reproduced by photography. Its cost of maintenance and too great sensitiveness are the points in which it fails to meet the requirements of an instrument for general adoption.

The so-called Omori pendulum is a horizontal pendulum presenting no special peculiarities, and is a modification, in details only, of a type of instrument in very general use. It fulfils all the first three requirements—being moderate in size, needing little attention, and gives good records, easy of interpretation and measurement. It fails in the fourth requirement only; the record, being taken on smoked paper, is not readily reproduced by photography, and is on too small a scale to obviate the risk of introducing error when copied by tracing.

The fourth type of instrument is the Milne pendulum, a horizontal pendulum with photographic record on a principle quite different from that adopted in any other instrument. This fulfils all the first three requirements, and the fourth too; the seismograms are easily reproduced by contact printing on to the same photographic paper that is used for recording, and the copies are practically as serviceable as the originals. This alone, if the instrument had few other merits, would mean much; but in addition to this I have found its seismograms the most convenient of any for determining the exact time of any point on the record, and had it not been for the general adoption of this type of instrument, and the ease with which its records can be reproduced, a considerable part of what seismological work I have been able to do could not have been attempted. The only improvement I have ever desired to see is an increase in the rate of movement of the recording surface, and this has now been introduced. I have examined and studied hundreds of records of this instrument from different stations; from Victoria, Toronto, Cape Town, Bidston, Paisley, and many other places, its records are consistently good; at a few stations, whether from a defect in the particular instrument, a want of proper adjustment, or, more probably, something in the foundations or the subsoil, its records are less satisfactory, but from none do they seem to be so bad as at Strassburg; having never seen a seismogram of that instrument—it is not easy to get copies from Strassburg—it is impossible to hazard a suggestion of the reason for the failure of the instrument at this station.

No one would wish to see one pattern of instrument adopted to the exclusion of all others, nor has it ever been pretended that the pattern adopted by the organisation which has grown up under the auspices of the British Association is faultless; but for the purpose of securing a large number of records for comparison with each other, and thereby determining the rate of transmission of earthquakes across, through, and around the earth, it is no

more faulty than any other pattern, and has one crowning merit which they do not possess. Can it be to this, to the ease of reproduction of its records, which renders unnecessary the centralisation of seismological research, that we must attribute the continuous viliification of a valuable type of instrument?

R. D. OLDHAM.

An Early Acoustical Analogue of Michelson's Echelon Grating.

IN the "Œuvres complètes" of Christiaan Huygens (tome x., p. 571) occurs the note given below. It was destined for Ph. de la Hire, and of date November, 1693. Huygens's remarkable observation and his ingenious explanation of the musical note produced by reflection from a large flight of steps of the noise of a fountain in the park of Chantilly will be read with interest also by those who, though having no ready access to the "Œuvres complètes," are still concerned with the (reflecting) echelon grating:—

"Je veux ajouter icy au sujet de la réflexion du son une observation assez singulière, que j'ay fait autrefois estant à la belle maison de Chantilly de la Cour où est la statue Equestre on descend avec un degré large de . . . marches dans le parterre où il y a une fontaine de celles qu'on appelle gerbe d'eau, qui fait un bruit continu. Quand on est descendu en bas et qu'on se tient entre le degré et la fontaine on entend du côté du degré une résonance qui a un certain ton de musique qui dure continuellement, tant que la gerbe jette de l'eau. On ne sçavoit pas d'où venoit ce son ou en disoit des causes peu vraisemblables ce qui me donna envie d'en chercher une meilleure. Je trouvoy bientost qu'il procédoit de la réflexion du bruit de la fontaine contre les pierres du degré. Car comme tout son, ou plustost bruit, réitéré par des intervalles égaux et très petits fait un son de musique, et que la longueur d'un tuyau d'orgue détermine le ton qu'il a par sa longueur par ce que les battements de l'air arrivent également dans les petits intervalles de temps que ses ondoiemens emploient à faire deux fois la longueur du tuyau sçavoir quand il est fermé par le bout, ainsi je concevois que chaque bruit tant soit peu distingué qui venoit de la fontaine, estant réfléchi contre les marches du degré, devoit arriver à l'oreille de chacune d'autant plus tard qu'elle estoit plus éloignée, et cela par des différences de temps justement égales à celui que les ondoiemens de l'air employent à aller et venir autant qu'estoit la largeur d'une marche. Ayant mesuré cette largeur qui estoit de 17 pouces, je fis un rouleau de papier qui avoit cette longueur, et je trouvoy qu'il avoit le même ton qu'on entendoit au bas du degré.

"Je trouvoy comme j'ay dit que la gerbe n'allant point l'on cessoit d'entendre ce ton. Et aiant eu occasion d'aller à Chantilly pendant l'hiver, qu'il estoit tombé beaucoup de neige qui estoit la forme aux marches, je remarquay que on n'entendoit rien quoique la gerbe allast et fit du bruit à l'ordinaire."

A slight confusion is caused by Huygens's first referring in his note (apparently only drafted) to a closed organ-pipe and later to an open one. Taking a pouce = 2.7 cm., the depth of the steps becomes $17 \times 2.7 = 45.9$ cm. At 16° C., the corresponding sound of about 368 vibrations per second would be given by an open pipe of 46 cm.

The effect of gratings on impulsive motion of light is now well understood, thanks to the labours of Lord Rayleigh, Gouy, Schuster, and others. It remains interesting, however, to contrast the opinion concerning the supposed regularity of white light, held by some high authorities before these discussions, with Huygens's statement that the regularity in the nature of the sound which he observed has been impressed upon it by outside influence.

P. ZEEMAN.

Amsterdam, January 6.

The Inheritance of "Acquired" Characters.

MAY I ask for information upon the interpretation of two sets of facts?

(1) Prof. Henslow states that the garden parsnip "known in the trade as 'The Student' was raised from seed of the wild plant by Prof. J. Buckman in 1847 at the Agricultural College, Cirencester," and also that M.

Carrière "raised several garden forms" of radish "of various colours from the seed of the wild species (*R. raphanistrum*), and found that they produced the long form in a light soil, and the turnip-rooted form in a stiff soil. A similar result has occurred with carrots. By selecting seed from plants having the best formed roots, these "characters" have become fixed and hereditary" ("How to Study Wild Flowers," 1902).

(2) I was delighted in the early summer by the marvelous skill and intelligence exhibited by some collies in the annual sheep-dog trials, which reveal apparently much more than the results of individual training. I have lately seen a pack of hounds streaming over the same country after a fox. The hound (*triste lupus in stabulis*) would make an indifferent sheep-dog, and the master who brought a pack of collies to a meet would provide some novel sport for the field. The collie is trained individually, but he has an inherent, if not inherited, aptitude, just as the foolishly good-natured hound puppy who is "put out to nurse" in his earlier days readily learns his work when he joins the pack. Further than this, an ordinary dog-show displays group peculiarities in different types of dog. The fox-terriers snarl savagely at each other, the grey-hounds and their allies bark and yelp continuously, and appear as though on the verge of neurotic insanity, while the foxhounds lie and appear to drowse silently with a well-bred air of tolerant boredom that forms a curious contrast to the howling multitudes around them. Yet they are all dogs, and have reached their typical specialisation by characters acquired in some way.

If we are forbidden to believe that acquired characters are hereditary, what is the explanation of the seed of the "student" parsnip and the "turnip" radish coming true to type, and why does a collie drive sheep and a hound give tongue at the scent of a fox? Is it suggested that in the "germ plasma" of the wild dog all these special qualities are already involved, just as the digestive protons gathered functionally and localised in the leaves of *Dionaea* and *Drosera* are found wandering aimlessly and to no purpose in some fruit trees? If so, what is the nature of the directive impulse that localises these characteristics in hound, collie, *Drosera*, and radish immediately fertilisation takes place? And again, how does the "peppered moth" contrive to appear in the black country hatched with sooty wings that harmonise with the now smoke-stained bark whereon he must rest? The whole subject of mimicry seems to be involved, and if your reviewer is right (*NATURE*, January 2, p. 193) in noting with "a sense of weariness mingled with surprise the appearance of a book on the transmission of acquired characters," it is quite certain that the "isolated biologists, and whole hosts of medical men who still hold the belief that acquired characters are transmitted" would regard it as a great boon if he would tell those who "make him tired" what are the conclusions apparently already established by "the modern, and still infant, science of heredity" that will satisfactorily account for such facts as I have ventured to state.

It will hardly do to say that in one sense the problem is "as unreal as the question of the apple dumpling which puzzled one of the Georges, because the characters of an organism do not get into its germ-cells any more than the apple gets into its crust, for both the germ-cells and the apple were there all the time." "One of the Georges" would doubtless have been grateful for a little culinary instruction, just as "whole hosts" of somewhat puzzled people with open minds would be honestly sincerely grateful for a definite explanation from "the infant science of heredity" as to how the sheep-driving impulse really got into the sheep-dog. For "nature" is more luminous than a text-book. E. C. SPICER.

Waterstock, Oxford, January 3.

The Diamantiferous Rock of Kimberley.

My friend, Dr. Hatch, is not quite correct in stating (January 9, p. 225) that I was led to dissent from the late Prof. Carvill Lewis's view that the diamantiferous rock of Kimberley was a volcanic peridotite "by a microscopic examination made in 1869 of specimens from the Newlands Mines" (*Proc. Roy. Soc.*, lxx., 1869, p. 223).

Four years earlier I expressed the opinion that this rock was a breccia, and that the diamonds, with other conspicuous minerals, were not formed *in situ* (*Geol. Mag.*, 1865, p. 500). This belief was strengthened rather than shaken by editing Prof. Carvill Lewis's notes and examining his specimens ("The Genesis of the Diamond"), and was expressed yet more decidedly later in 1867 after examining another series of specimens from Kimberley (see *Geol. Mag.*, 1867, p. 501). To discuss the "magma" and "concretion" hypothesis would be out of place here, but elsewhere I may have something to say on those subjects.

T. G. BONNEY.

Musical Sands.

MR. CARUS-WILSON'S failure (January 9, p. 222) to obtain sounds from "millet seed" sand of highly spherical grains puts a difficulty in the way of the suggestion made in "Sound" by Poynting and Thomson, though I do not think that it finally disposes of it.

I have not been able to follow the friction explanation as given by Mr. Carus-Wilson (*NATURE*, August 6, 1891), and I write in the hope that he may give more detail as to the moving system which produces the musical note. It appears probable that the musical sounds excited in a body by friction are due to the natural vibrations of that body. Obviously the grains of sand are far too small to give the notes heard. I suppose that the fundamental period is of the order of the time taken by an elastic wave to travel half round the grain. With elastic moduli of the order 10^{11} and density 2½, the fundamental frequency would be not less than 10^6 . What system does the friction set in vibration? J. H. POYNTING.

The University, Birmingham, January 11.

IN *NATURE* of January 9 (p. 222) Mr. Carus-Wilson's letter asks for further details of the "singing sands" that I exhibited to the Physical Society. I am able to give the mineralogical description, by Mr. A. J. Maslen, of the Maine sand from Maren's beach, near Small Point, at the entrance of the Kennebec River.

A subangular sand very fine from very small grains. Clean.

Quartz. Principal constituent. As perfectly colourless-grains showing conchoidal fracture (rock-crystal) and as more or less coloured grains of quartzite.

Muscovite Mica. Small quantity. Flakes.

Glaucite. Dark green grains, many of fairly large size. Almost black.

Topaz (?) Square pieces due to cleavage. Yellow.

Opaque white substance. (Felspar?)

Magnetite. Small grains. Rare.

The other specimens of sands were very similar to that from Maine. SIDNEY SKINNER.

South-Western Polytechnic, Chelsea, S.W.,

January 13.

Intensity of Spectrum Lines.

VERY little attention has been paid in the past to the accurate measurement of the optical intensity of spectral lines in vacuum tubes under different conditions, probably on account of the considerable experimental difficulties. Hence I may, perhaps, be allowed to indicate a relation I have obtained between the optical intensity, current strength, and pressure of the glowing gas. Throughout the whole experimental range, using the so-called "electrodeless" tube—with wholly external mercury electrodes, when the current is of a slowly oscillating character—the optical intensity, with an end-on tube, is accurately proportional to the readings of a thermo-galvanometer in series, and over a more limited range of measurement, at constant current, is inversely proportional to the pressure of the gas.

In other words, the intensity is proportional to $\lambda \int c^2 dt$, where λ is the mean free path.

Measurements on the monatomic gases are now in progress, and it is intended later to investigate the influence of temperature.

A. D. COWPER.
University College, London, W.C.

NOTES ON ANCIENT BRITISH MONUMENTS.¹

IV.—Avenues.

I HAVE measured several avenues since "Stonehenge" was published, and I have studied others of which the orientation could be determined by the Ordnance maps. Many of them have been found to have had the same astronomical use which had been suggested in those measured on Dartmoor. The longest avenue I have seen is at Avebury—the Kennet Avenue—which, in Stukeley's time, was more than a mile long. Associated with it is the Beckhampston Avenue. These avenues must have been very imposing parts of the complete temple when it was in full use. Avebury is such a mass of ruins that it is difficult to reconstruct it in the mind's eye in its entirety, but some parts of it, considered by themselves, present no difficulty. Mr. R. H. Caird, of Devizes, has twice enabled my wife and myself to visit the region by driving us from Devizes in his motor-car, and these visits gave us time enough to see that the Beckhampston Avenue and the remains of the Cove were both oriented to the May sunrise, were, in fact, probably closely associated in the May ceremonies, the avenue abutting on the north circle, in the centre of which the remaining gigantic stones of the cove still stand.

The theoretical conditions for the azimuth of the May sunrise at Avebury (lat. $51^{\circ} 30'$, variation $16^{\circ} 48'$ W. in 1906), are, with $2'$ of limb showing:

N. 62° E. with sea horizon
 $63^{\circ} 40'$ " hills $1'$ high
 $65^{\circ} 12'$ " " " $2'$ "

A rough measurement on the spot gave me N. 62° E. for the outlook of the cove, the horizon being about $2'$ high, and on the 1-inch Ordnance the line joining the two large monoliths at the west end of the Beckhampston Avenue and the cove gives N. 64° E. Further, this line studied on the 25-inch map passes close to the stones indicated by Stukeley, who expressly says that he saw the remains of the avenue. I give his description.²

"The Beckhampston Avenue goes out of Abury town at the west point, and proceeds by the south side of the churchyard. Two stones lie by the parsonage gate on the right hand. Those opposite to them, on the left hand, in a pasture, were taken away in 1702, as marked in the ground-plan of Abury. Reuben Horsal remembers three standing in the pasture. One now lies in the floor of the house in the churchyard. A little farther one lies at the corner of the next house on the right hand, by the lane turning off to the right to the bridge. Another was broke in pieces, to build that house with in 1714. Two more lie on the left hand opposite. It (*i.e.* the Avenue) then passes the beck south of the bridge. Most of the stones hereabouts have been made use of about the bridge, and the causeway leading to it."

Smith's account goes on:—

"Moreover, we have some evidence of the exist-

¹ Continued from p. 152.

² Avebury described, p. 34, quoted in Smith's "British and Roman Antiquities of North Wiltshire," p. 146.

ence of the avenue in this direction, in the fragments of sarsen stones which may still be seen there, as the Rev. Bryan King has pointed out in his note on this subject, to which I have already called attention;¹ therein he says: "Beginning with the walls of the churchyard and of the church, and of the manor-house, with its enclosures, in an entire length of full half-a-mile from the earthwork on the west side of Avebury to the corner of the large field in which the two large stones near Beckhampston now stand, there are very few lineal yards which are not occupied by causeway, walls or cottages, all formed of sarsen stone, sufficient and more than sufficient, to absorb all the stones of the Beckhampston Avenue"; and then he goes on to enumerate the several stones, or portions of stones, which still exist, and which are apparently the remnants of those described by Stukeley."

On the accompanying plan of Avebury, photographed from the 25-inch Ordnance map, I have indicated the two circles as roughly determined from the

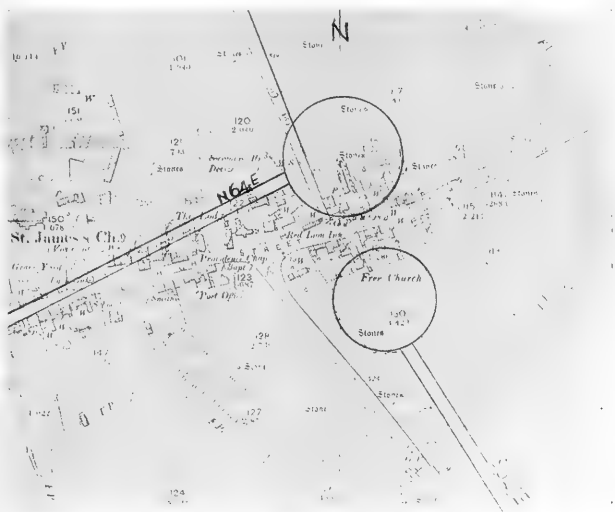

FIG. 11.—Avebury, showing the circles and avenues.

remaining stones. It will be seen that the May-year avenue line is directed nearly, but not quite, to the centre of the northern circle, the cove occupying the centre itself, and so blocking the view from the avenue or processional road to the S.W.

I next come to the south-eastern or 'Kennet Avenue.' Stukeley² says of it: "The Kennet Avenue consisted originally of one hundred stones on each side, reaching from the vallum of Abury town to the circular work on Overton Hill. Mr. Smith, living here, informed me that when he was a schoolboy the Kennet Avenue was entire from end to end. The stones composing it were of all shapes, sizes, and heights that happened, altogether rude. Some we measured six feet thick, sixteen in circumference. If the stones were of a flattish make, the broadest dimension was set in the line of the avenue, and the most slightly side of the stone inward. The founders were

¹ *Wiltshire Magazine*, vol. xviii., pp. 227-235.

² Avebury described by Stukeley, quoted in "British and Roman Antiquities of North Wiltshire," p. 145.

sensible that all the effect desired in the case was their bulk and regular station. When I abode here for some time on purpose, for several summers together,



Photo. by Lady Lockyer.

FIG. 12.—One of the Monoliths at Borobridge.

I was very careful in tracing it out, knew the distinct number of each stone remaining, and where every one stood that was wanting; which often surprised the country people, who remembered them left on the ground or standing, and told me who carried them away. Many of the farmers made deep holes and buried them in the ground; they knew where they lay. Lord Winchelsea with me counted the number of the stones left, 72, anno 1722. I laid it all down in the nature of a survey, on large imperial sheets of paper, and wrote a detail of every stone present or absent; but it would be very irksome to load the press with it." Mr. Long, after describing the war of extermination which had been waged against them, and how such stubborn blocks as refused to succumb to fire and hammer were buried in the pits dug for them, continues: "Two of them lie six feet underground in the premises of Mr. Butler of Kennet, and over another the Bath road passes. The work of destruction has been so successfully carried out that only nineteen stones or their stumps are now visible between West Kennet and Abury; four in the bank on the left-hand side of the road from Marlborough as it enters Kennet, and which can only be seen by going into the adjoining field: these stones lie about thirty paces apart, and

that these were the original, or nearly the original, distances, seems confirmed by Stukeley's twentieth plate."¹

As will be seen from the map, this avenue apparently was connected with the southern circle as the Beckhampton one was with the northern one. If this were so, certainly the enormous bank, erected apparently for spectacular purposes, which is such a striking feature of Avebury, was not made until after the Kennet Avenue had fallen out of any astronomical use.

The alignment of this avenue, as measured on the 25-inch map, is S. 32° E., the elevation of the horizon from the 1-inch map being 49'. This gives a declination of 31° 34' S. I shall return to this point later on.

This avenue seems to have struck another aligned from the circle on Overton Hill, which formerly was oriented to the May sunset or the November sunrise, to judge from the positions of the stones given in Smith's map.

At Borobridge, near Harrogate, is another avenue I have visited; only three stones remain, two have disappeared in recent times, the extreme stones being separated by about 700 feet. They are not in a line. Lukis was the first to suggest that they were the remains of an avenue, and I agree with him. According to my measurements the breadth of the avenue was about 25 feet. With a clinometer the mean of three readings gave N. 355° E. as the magnetic azimuth; taking the variation as 17° (October 4, 1907), this gives us S. 22° E. or N. 22° W.; the true northern horizon is 1½° high, the southern one 1°.

I give a copy of a photograph of the central stone; this seems to have been squared, and the east and west sides are slightly slewed from the general line of direction.

Mr. Lewis,² in an interesting account of these stones, tells us that the most northerly stone is 18 feet high by 7½ by 3½ feet, the second (the one illustrated), 19½ feet away, 22 feet high by 4½ by 4½ feet; and the southerly one, 362 feet away, 23 feet high by 4½ by 4 feet. They are called locally the Devil's Arrows.

Of another Dartmoor avenue, that at Assacombe, in



FIG. 13.—Assacombe Avenue looking west.

the Chagford district, I am enabled, by the kindness of Mr. Falcon, the author of "Dartmoor Illustrated"

¹ *Wiltshire Magazine*, vols. iv., pp. 327-9; xvii., pp. 329-31.

² *Journal Anthropological Institute*, November, 1878.

(a book which everybody interested in the monuments should possess), to give two photographic views from the east and west ends. It is a May-year avenue (Az. N. $63^{\circ} 30'$ E., from 25-inch Ordnance map) like the Beckhampton Avenue at Avebury.



FIG. 14.—Assacombe Avenue looking east.

It will be noticed that, like the avenues at Merrivale, the row of stones is furnished at the west end with monoliths larger than ordinary, and that the other end has a well-marked blocking or sighting stone ending the avenue.

I may here refer to yet another May-year avenue which I measured in South Wales. It is near "Arthur's Stone," a famous cromlech in Gower to which I refer elsewhere. The true azimuth is S. 61° E., height of horizon $1^{\circ} 30'$.

There is no doubt, I think, that the "Nine Maidens" near St. Colomb, Cornwall, of which a plan is given by Lukis (plate xxxii.), is the remains of a double or multiple avenue. With Lukis's value of the magnetic variation, I found from his plan an azimuth of N. 28° E. I visited them in April, 1907, and assuming a variation of 18° W. (with hill 2°), I got the same value, giving Dec. N. $33^{\circ} 47'$: that of Capella in 1480 B.C.

This is a locality worthy of minute study, especially with reference to the actual commencement of the

avenue, for the true azimuths of the many stones on the E. side of course depend upon this.

This avenue and the fine one at Callernish can be treated together. For the latter the conditions are as follows:—

Azimuth of Avenue.—N. 9° E.; hill, $1^{\circ} 26'$; dec. $32^{\circ} 26'$ N.; Capella, 1720 B.C.

This avenue is associated with a circle 42 feet in diameter, within which is a remarkable chambered cairn referred to elsewhere. The avenue consists of two parallel lines going off to the northward 270 feet in length, and about 27 feet in width. The total number of stones is forty-eight, and the total length of the monument, from the extremity of the double line, through the centre of the circle to the extremity of the single line beyond, is 408 feet.

It will be seen, then, that the more recent measurements give us avenues directed, on the orientation theory, both to sun and stars. The sun is the May sun, and the solar avenues are at Avebury, Assacombe, and Gower.

Of new stellar avenues parallel to others previously shown by the investigations to be aligned on northern clock-stars, we have those at Callernish and St. Colomb.,

But these are not all.

NORMAN LOCKYER.

THE CALIFORNIAN EARTHQUAKE OF 1906.

ALTHOUGH only twenty months have passed since Central California was devastated and San Francisco destroyed, partly by earthquake but largely by fire, some fifty papers have appeared from technical and other journals describing this great catastrophe. The last appears as a Bulletin (No. 324, Series R, Struc-



FIG. 15.—The Nine Maidens.

Photo, by Lady Lockyer.

tural Materials, 1) of the U.S. Geological Survey. It is a volume of 158 pp., illustrated by fifty-seven excellent process plates, in addition to which there are two maps. The introduction is by Dr. G. K. Gilbert, and it treats of the earthquake as a natural phenomenon.

The earthquake, Dr. Gilbert tells us, had its origin chiefly along the line of an old fault. This can be traced from San Juan, about ninety miles south-east of San Francisco, to Point Arena, about 120 miles north-west of that city, the total length being approxi-



FIG. 1.—Fence parted by Earthquake Fault. The fault trace or fracture accompanying the earthquake is inconspicuous although the horizontal displacement is considerable. (Photograph by G. K. Gilbert.)

mately 200 miles. There are, however, good reasons for believing that the fracture extends very much farther to the north. The total length of the line of yielding would therefore have been 300 or even 400 miles. Its general appearance is that of a huge furrow, the displacement of one side of which relatively to that of the other side has varied from 2 to 20 feet. In Fig. 1 the furrow-like appearance is not visible, but the fence, which is broken across and shifted 8½ feet, indicates the existence of a sheer, the trace of which is hidden.

The vertical displacements were comparatively small. Passing out from the main fault are branching cracks. These are particularly noticeable in soft ground. The depth to which this shattering has extended cannot be directly measured, but that it has descended to a considerable depth is indicated by alteration in the general circulation of underground waters. New springs have been created, whilst old springs have been closed or altered in their flow. The great length of the main fault suggests that it had a great depth. Further, the initial impulse was sufficient to send earth waves round the world it is reasonable to suppose

but this was occasioned by the sudden displacement of a very large earth block. We know something about its length. Its breadth may be estimated from its distance from more or less parallel faults which yielded or from the width

of the area of the molar displacement. Its thickness may be that of the earth's crust. A suboceanic mass movement of this size might disturb the Pacific Ocean for twenty-four hours, or shake the world from pole to pole. Were it very much less it is difficult to imagine

that such far-reaching commotions could be originated. This may be mere speculation, but to shake the world a heavy blow needs to be applied over a considerable area. A curious observation relating to the length of earthquake waves was made in Tomales Bay, where, before the earthquake, there was the usual smooth mud plain commonly seen on tidal flats. After the earthquake this plain was ridged, the crests of the ridges being ten to twenty metres apart. Whether these represent the solidification of gravity waves we are told is not quite clear, but whatever their history may have been, they illustrate the response of a mud flat to earthquake motion.

The major and most important part of the publication is written by three engineers, Messrs. R. L. Humphrey, J. S. Sewell, and Prof. Soule. All have had experience of fires, whilst Prof. Soule has for many years watched the growth of San Francisco and was present at its fall. We are told that the whole secret of earthquake-resisting power depends upon "proper design, first-class materials, and honest workmanship." The first condition, inasmuch as it involves radical changes in methods of ordinary construction,



FIG. 2.—Memorial Arch, Leland Stanford Junior University. Earthquake Effect:—The beams designed to stiffen the walls were not tied to them, and helped to batter them down when the shock came. (Photograph by Richard L. Humphrey.)

might have been underlined. The greatest destruction came from fire, and the modern structures which best resisted both fire and earthquake seem to have been those made of reinforced concrete. Tunnels, flumes, wrought and cast-iron pipes, particularly where

they crossed the fault line, were interrupted, but the chief reason that fire gained the upper hand was the failure of the water systems in the city. Steel skeleton buildings withstood the earthquake, but although these and their supporting columns had been encased in fire-resisting material, under the effects of heat the protecting surfaces flaked off. Internal metal-work expanded, buckled, and then collapsed. Fire-proofing had been inefficient. Although there is much of scientific interest in the bulletin, its chief value will be to the practical engineer, who has to contend against, not simply the effects of earthquakes, but chiefly against the effects of fire.

PUBLIC CLOCKS AND TIME DISTRIBUTION.

THE interesting correspondence on "Lying Clocks" inaugurated by Sir John Cockburn in the *Times* has tended to degenerate into a display of advertisements by different firms interested in various systems of clock synchronisation. But in its original form, the point raised is one of great importance, and if it is not appreciated by the public as fully as it should be, the explanation is probably to be found in the general contempt for accuracy exhibited in this country, and the non-scientific habits which have been so long cultivated or permitted. It seems impossible to get the man in the street to understand the significance of seconds. He is ready with his old adage, *De minimis non curat lex*, and thinks he has settled the question. But this is not so, and the interest taken in the *Times* discussion indicates the possible introduction of a healthier state of things. We may look forward to a time when every progressive town or city will be provided with clocks, publicly exhibited, which will declare the correct time. If such mechanism were provided, it would not only tend to economy in various directions, owing to the more complete appreciation of small intervals of time, but such clocks would furnish a wholesome lesson in accuracy, and by the introduction of scientific processes into everyday life inculcate the importance of paying greater attention to scientific methods.

The term synchronisation seems to be used very vaguely. For its successful operation, two distinct processes have to be considered—the distribution of correct time signals and the control of local clock dials. Some seem to think that the problem would be sufficiently solved if clocks were all made to show the same time. This result could be ensured by simple methods of control, and it is true that so long as we remained in one town the annoyance of a "lying timekeeper" would not have to be tolerated, but the uncertainty would reappear as soon as we entered another town, and the only way to secure uniformity is to arrange for the exhibition of correct standard time. This essential preliminary of the distribution of correct time signals is provided for by the Post Office authorities, working in cooperation with the Royal Observatory, Greenwich. The telegraphic service throughout the country is suspended for a few seconds, while the signal is sent through the trunk lines at 10 a.m. But, unfortunately, it is to be feared that the duty of forwarding this signal to the smaller towns is very carelessly and inefficiently performed, simply because the officials who are responsible for its wider distribution have not sufficiently apprehended the necessity for accuracy. From personal experience we are afraid that this signal is not sent on automatically. Here is the first necessity for reform. If it were thoroughly well known that there did exist in every town and village an office where correct time could be had, even at some personal inconvenience careful people would take the trouble to

keep their clocks fairly accurate, and by so doing gradually educate the more indifferent to a higher standard.

The control of the clock dial is a much simpler matter, and has passed into the commercial stage. The convenience of having a number of clocks in one establishment indicating the same minute is so evident that a variety of patents has been secured with the view of effecting this purpose. But most of the patentees do not concern themselves with extreme accuracy, and are content if no greater difference than half a minute can be perceived between any dial and the master clock, from which the signal is sent generally at intervals of half a minute. There are several processes which can be easily utilised, some of which are admirably adapted for outside dials, and could be supplied at small cost. Probably it would not be wise to insist on extreme accuracy, but to endeavour to establish a system that could be improved. The trouble is that London, and other large towns generally, have no system of clocks under municipal control which could be synchronised. It is necessary to make a new departure, and the discussion in the *Times* is so far valuable that it tends to create a public opinion, which may induce the authorities to take the initiative.

LORD KELVIN AND THE ROYAL SOCIETY OF EDINBURGH.

ON January 6, at the first meeting of the Royal Society of Edinburgh since the death of the president, Lord Kelvin, Prof. Crum Brown, F.R.S., vice-president, read the following appreciation, a copy of which has been communicated to us by the society:—

We meet here to-night for the first time since the death of Lord Kelvin.

This is not the time to enter into an enumeration or a criticism of what he did. Our thoughts now are of the loss which we have sustained. But it is impossible in our mind to separate the man from his work. For the transparent truthfulness, the simplicity and straightforwardness, the absence of the least trace of affectation or trick, which contributed so much to the charm of his manner, felt by everyone who came, even in the slightest and most transient way, into relation with him, are to be seen in all that he did. It was his love of truth and his sympathy with nature that led him in all his investigations directly to the root of the matter, and made him so zealous and successful in his searches for the essential principles underlying the phenomena of nature. And when a truly essential new view was obtained, by himself or by another, of the way in which nature works, he rejoiced greatly, and called on his friends to rejoice with him. Nature was to him very real, and no demonstration seemed to him quite satisfactory until it had been "realised." This and his sympathy with men and with their work gave everything to him a practical aspect. And so in almost every direction in which he worked he devised working models and instruments of precision. Some of these are known only to specialists, and by them used and valued, but everybody has heard of his compass and of his sounding apparatus, and knows something of the enormous benefits he has conferred on navigation.

It was not only in pure and applied science that he was interested; everything that affects the life of the people, education, politics, religion, occupied his thoughts, and on all subjects which he had seriously considered he had definite opinions. While he would, on occasion, defend with zeal and energy what he believed to be the truth, he was always perfectly fair to his opponents, as he was always courteous to everybody.

We have already had emphatic evidence that the world knows that a great and good man has left us; we who knew him more intimately also mourn a dear, trustworthy, and trusted friend.

NOTES.

M. BILLAUD, director of the Toulouse Observatory, has been appointed director of the Paris Observatory.

SIR GEORGE DARWIN, K.C.B., F.R.S., has been elected a corresponding member of the Imperial Academy of Sciences of St. Petersburg.

LIEUT.-COLONEL R. E. CROMPTON, C.B., has been elected to the presidency of the Institution of Electrical Engineers vacant by the death of Lord Kelvin.

PROF. BOUCHARD has been elected a vice-president of the Paris Academy in succession to M. Henri Becquerel, who has passed to the presidential chair.

THE Hayden memorial geological medal of the Academy of Natural Sciences of Philadelphia has been awarded to Mr. C. D. Walcott, secretary of the Smithsonian Institution.

WE regret to see the announcement of the death of Lieut.-Colonel R. L. J. Ellery, C.M.G., F.R.S., late Government astronomer and director of the Melbourne Observatory, at eighty years of age.

WE learn from the Paris correspondent of the *Chemist and Druggist* that the appointment of Prof. E. Jungfleisch, of the Paris Superior School of Pharmacy, as successor to Berthelot's chair of organic chemistry at the Collège de France was formally signed by M. Briand on January 6.

THE Geological Society of London will this year award its medals and funds as follows:—Wollaston medal to Prof. Paul Groth, of Munich; Murchison medal to Prof. A. C. Seward, F.R.S.; Lyell medal to Mr. R. D. Oldham; Wollaston fund to Mr. H. H. Thomas; Murchison fund to Miss Ethel G. Skeat; and Lyell fund to Mr. H. J. Osborne White and Mr. T. F. Sibly.

REPORTS have appeared in the daily Press of a new treatment for consumption in which the diseased portion of the lung is removed by operation. The only novelty seems to be the use of hot water or steam to control the hæmorrhage, for excision of a portion of the lung has occasionally been performed during the last seventy years. Such a procedure could only be of service in a very few selected cases.

WE deeply regret to announce the death of Prof. C. D. West on January 10 in Tokyo. He had then been twenty-five years in the service of the Japanese Government, and was one of those men the Japanese did not wish to lose. He never cared to write scientific papers, but his thought can be traced in those written by others. "West's formula" relating to the destructive power of earthquakes is certainly the basis of all other formulæ on this subject, and these have had a wide application. He was a pioneer in the education of engineers in Japan, and is looked up to as the father of engineering in that country. A modest man has been called across the bar.

As the result of a vigorous sanitary campaign, involving an expenditure of more than 40,000*l.*, bubonic plague has now been almost eradicated from San Francisco. One of the most notable features has been the destruction of 150,000 rats during the last four months. Of this number, 11,391 were examined by bacteriologists in the laboratory of the Health Department, and 108 were found to be infected. Up to the end of December, 1907, the total number of persons reported as plague-stricken was 136, of whom seventy-three died. The sanitary measures adopted

have been under the control of an officer of the U.S. Marine Hospital Service, with the cooperation of the local health authorities.

New awards will shortly be made from the "Elizabeth Thompson Science Fund," which was established "for the advancement and prosecution of scientific research in its broadest sense," and now amounts to 5200*l.* Applications for assistance from this fund should be sent promptly, with full information, to the secretary of the board of trustees, Dr. C. S. Minot, Harvard Medical School, Boston, Mass., U.S.A. The trustees are disinclined, for the present, to make any grant to meet ordinary expenses of living or to purchase instruments, such as are found commonly in laboratories. Decided preference will be given to applications for small amounts, and grants exceeding 60*l.* will be made only in very exceptional circumstances.

In honour of the memory of the great Russian chemist Mendeléeff, a Congress of Chemistry and Physics was held at the University of St. Petersburg on January 2-12. The congress was organised by the Russian Physico-Chemical Society, and the following telegram, signed by Prof. Borgmann, Rector of the Imperial University, who presided, was sent to Sir James Dewar—"The Russian Physico-Chemical Society, with members of the first Mendeléeff Congress, express to you—a friend of the late Prof. Mendeléeff—great esteem for your scientific labours opening new ways for investigations of Nature." Many British men of science will be glad that their Russian colleagues have thus shown their appreciation of the greatness of Mendeléeff's work and of the high regard in which his memory is held in this country. This sympathetic feeling and unanimity of aim among scientific men is of international importance, and makes the congress at St. Petersburg an event in which the whole scientific world is interested.

MR. HENRY FARMAN on Monday won the Deutsch-Archdeacon prize by flying toward a goal previously fixed and returning to the starting point, the total distance being more than one kilometre, with a machine heavier than air. The course was marked out by delegates of the Aero Club of France upon the military ground of Issy. Five hundred metres from the starting point, two posts were placed fifty metres apart, and the conditions of the contest were such that the aeroplane had to pass between these posts in the journeys both out and back. At the starting signal the machine ran along the ground for a few yards and then rose easily in the air and headed toward the turning post. This point was reached by a steady flight, and after sweeping round it, Mr. Farman returned to the starting point with perfect ease. The entire flight occupied 1m. 28s. A description, with an illustration, of Mr. Farman's aeroplane was given in *NATURE* of December 5, 1907 (p. 106).

An electrical engineer, M. Lemoine, is under arrest in Paris charged with having obtained more than 60,000*l.* from Sir Julius Vernher in connection with an alleged invention for the manufacture of diamonds. The "secret" of the process was deposited in a London bank at the time the negotiations were entered upon, and the magistrate appears to be in a legal difficulty, since the defendant refuses to allow the document to be examined. The defendant has, it is reported, given several demonstrations of his process, and some of these were in the presence of witnesses. During the progress of the case, a *Times* correspondent states:—"An Englishman, Mr. Jackson, said that he had been present at two experiments in M.

Lemoine's laboratory. Mr. Jackson himself compounded the substances, put them into a crucible, and sealed it up. M. Lemoine then ran the crucible into an electric furnace, and after about twenty-five minutes he drew the crucible out. Mr. Jackson opened it, and found in it twenty-five little diamonds. At another time they obtained thirty. He offered the diamonds to a London jeweller, who found them very fine, and an expert to whom he showed them thought they came from Jagersfontein.¹ A representative of the *Daily Chronicle* has had an interview with Lord Armstrong, who was present at one of the demonstrations, and affirms that diamonds were really produced. Lord Armstrong is reported to have said:—"M. Lemoine handed me a powder, which, in order to convince myself, I worked up with my fingers. It was nothing but a powder. I myself put this powder into an empty crucible, which I closed again, and I personally put the crucible into the furnace. When, under the instruction of M. Lemoine, who stood some distance from me, and could in no way interfere in the operation, I withdrew the crucible I found in it an agglomerated mass, which I allowed to cool before my eyes. I myself broke this shapeless mass, which presented the appearance of carbonised matter, and there I found these pure diamonds and these other diamonds less perfect." As the case has not yet been decided, it is undesirable to comment upon it at this stage. So far as we have seen the evidence, nothing is added to what has been known by chemists since Prof. Moissan found that diamonds could be produced by allowing carbon to crystallise from solution in molten iron or silver. Prof. Moissan used pure sugar charcoal to obtain his artificial diamonds. This carbon was compressed in a plugged cylinder of soft iron which was placed in a crucible containing iron rendered molten by an electric furnace. The best crystals were obtained when the crucible was afterwards cooled rapidly by immersion in molten lead. As these particulars have been matters of scientific knowledge for the past fourteen years, the Reuter telegram from Paris that the substance of the formula contained in the sealed envelope is as follows, is amusing reading:—"Take carbon of sugar, place it in a crucible, and heat to the requisite temperature. The result will be diamonds."

We have to acknowledge the receipt of a copy of No. 18 of the Bulletin of the Imperial Academy of Sciences of St. Petersburg for 1907, which contains, among other articles, an account by Dr. W. Salensky of the interesting acelous turbellarian worm *Haplodiscus ussowii*, a species named in 1896.

THE fifth number of vol. ii. of the *Philippine Journal of Science* is almost exclusively devoted to ornithology, no fewer than fourteen out of fifteen articles dealing with this subject. A number of new species (one referable to a new genus) are described, but perhaps the most generally interesting article is one on the rare monkey-eating eagle (*Pithecophaga jefferyi*) from Mindanao and Luzon. None of the specimens was perfect, and no additional information appears to have been ascertained with regard to the habits of this remarkable species.

IN *British Birds* for January, Messrs. Bentham and Mouritz record the breeding of the hen-harrier and the hobby in Surrey in 1907. A nest of the former was discovered in May, originally containing four eggs, out of which two were hatched, and in due course the young took wing. Sad to relate, both parents were shot by a gamekeeper, and there is some doubt whether the young birds survived. In the same issue Mr. J. B. Nichols records a specimen of the grey-backed warbler (*Aedon*

familiaris) shot at Hythe, Kent, in July, 1907, this being the first occurrence of the species in Britain. It breeds in Asia Minor, Turkey, Greece, and further eastwards. The allied rufous warbler (*A. galeatodes*) has occurred thrice in England and once in Ireland.

WHETHER or no they agree with all the opinions expressed, readers of the January number of the *Fortnightly Review* will unite in welcoming an article on "Evolution and Character" by the veteran evolutionist Dr. Alfred Russel Wallace. Despite the absence of any advance in human character during the whole period of which we have any definite ken, such an advance will, in the author's opinion, make itself apparent in the not distant future. It is added, however, that "our imperfect human nature . . . can only make a systematic advance through the thoroughly sympathetic and ethical training of every child from infancy upwards, combined with that perfect freedom of choice in marriage which will only be possible when all are economically equal, and no question of social rank or material advantage can have the slightest influence in determining that choice."

ACCORDING to the latest report of the Liverpool Marine Biology Committee, the Marine Biological Station at Port Erin, Isle of Man, has had a most successful year's work, this being especially the case at sea, where greater activity in submarine exploration than in any previous season was rendered possible by means of a steam-yacht. This yacht, although small, has been fitted with apparatus for dredging, tow-netting, and various other purposes in the comparatively deep water outside the bay, and it is hoped that she may be available for much further exploration in the Irish Sea. The aquarium, to which nearly sixteen thousand visitors were admitted during the summer, continues to be a great success. As regards the economic side of the work, the number of plaice larvae hatched was considerably below the average, a large percentage of the eggs being infertile. Lobster-culture, on the other hand, made steady progress, although it was found that the experiment of placing the "berried" lobsters in one of the ponds did not prove a success.

A FEW weeks ago we referred to a paper by Mr. Graham Renshaw on the Californian condor (*Gymnogyps californianus*). In the *Century Illustrated Magazine* for January appears an article by Mr. W. L. Finley based on several visits to the actual haunts of the bird, and illustrated with photographs of the egg, young, and adults taken at close quarters. The interviews took place high up in the San Bernardino Range of southern California, and one of the most remarkable events was the near approach the writer and his companion were able to make to the old birds without any manifestations of alarm or fierceness on the part of the latter. These birds, it appears, lay only a single egg in a season, and the young is of remarkably slow development, the black quill-feathers not showing until the nestling is more than two months old. It has been ascertained that there are only forty-one eggs of the species in collections (against about seventy of the great auk), and the number of adult birds in captivity is half a dozen. The photographs obtained during these trips—which include several of the young at different stages of development—are claimed to be absolutely unique.

An example of a plant which sheds its leaves in summer is afforded by *Euphorbia dendroides*. The large yellow bushes which in winter time adorn the Jurassic limestone rocks on the northern shores of the Mediterranean are represented in August by a network of bare brown ramify-

ing stems. In September the new leaves begin to sprout for the winter growth.

PROF. M. C. POTTER records in a leaflet his observations on a barley disease prevalent in the north-eastern counties last year, producing undeveloped grains known locally as "deaf ears." Examination of diseased flowers showed that development had followed a normal course until pollination had taken place, but at this stage arrest of development in the ovary was caused by the attack of the fungus *Helminthosporium gramineum*.

In the *Verhandlungen des Vereins zur Beförderung des Gewerbfleißes*, Berlin, is published the substance of a lecture delivered by Dr. F. Frank before the society on caoutchouc, dealing mainly with its exploitation from natural sources and on plantations, also with the methods of its preparation and the regeneration of old rubber. Reference is made to the development in Mexico of a trade in *guayule*, the substance obtained from the shrub *Parthenium argentatum*, that is worked up in local factories. Special information is furnished with regard to plantations and methods of treating the crude latex of different rubber trees in German colonies in Africa and New Guinea.

In connection with the problem of natural regeneration of forests in tropical and subtropical climates, an article contributed by Mr. A. W. Lushington to the *Indian Forester* (October, 1907) on sucker reproduction in certain forest reserves and jungle scrub in the Kistna district of Madras points to the importance of this mode of regeneration. The grouping of shrubs of *Bauhinia tomentosa* and *Ormocarpum* suggested that they were not produced from seedlings, and subsequent examination showed that sucker reproduction was the potent factor, not only in the spread of the shrubs, but also of the trees. A note by Mr. Daya Ram in the same number refers to the sporadic flowering of *Strobilanthus Wallichii* and *Strobilanthus alatus* in 1906 in the United Provinces. Previous flowerings were recorded in 1894 and 1882, giving twelve years as the normal life-cycle of these species.

FROM the Royal Botanic Gardens, Kew, we have received the final part (No. 10) of the *Kew Bulletin* for 1907, and appendix v. to the same volume, containing a list of literary contributions by members of the staff during the years 1866 to 1906. In the case of systematic papers, it has been thought useful to add to the title the names of new species. In the *Bulletin*, Dr. O. Stapf furnishes an account of the gums ammoniac of Morocco and the Cyrenaica. The latter, which is the gum ammoniac described by Dioscorides, is referred to *Ferula marmarica*. The Morocco product has been identified as a variety of *Ferula communis*. The gum ammoniacum of European markets to-day is yielded by the Persian plant *Dorema ammoniacum*, which has ousted the African drug. Mr. W. Dallimore contributes an article on gardens of interest near Newport, Mon., making special reference to tree cultivation. In another article attention is directed to Zapupe fibre, the product of an undetermined species of Agave that is proposed as an alternative to the sisal Agave in tropical countries such as the West Indies.

THE report of the early proceedings at the West Indian Agricultural Congress, held in Jamaica in January, 1907, together with the papers that would have been read but for the earthquake, has been published in the *West Indian Bulletin* (vol. viii., parts i. and ii.). A review of the year's work in connection with the more important agricultural industries was presented by Sir Daniel

Morris in his presidential address. On the subject of sugar canes, Mr. J. R. Bovell and Mr. F. A. Stockdale discuss new seedling varieties and the methods of obtaining hybrids. Artificial cross-fertilisation offers so many difficulties that other methods, such as planting alternate rows of two selected varieties throughout a plot, have been adopted. Cacao, pine-apples, limes, and cotton provided the subjects for several papers. With regard to varieties of rubber, it is noticeable that *Castilloa* has received more attention than Hevea. Mr. B. H. Jones, writing about the collection of rubber in the forests of British Guiana, makes special reference to three indigenous species of Sapium.

A RETURN of the frost occurred during the past week over the whole of England, and in many places the thermometer fell as low as in the severe frost in the early part of the month. At Greenwich the thermometer in the screen registered 19°.1 on the morning of Saturday, January 11, while on the grass the temperature was 11°.1, and on Sunday the shade reading was 17°.9, which is in agreement with the lowest temperature in the earlier frost, whilst the exposed thermometer fell to 8°.8, which is more than a degree lower than during the previous frost. Among the lowest temperatures reported to the Meteorological Office on Sunday, January 12, were:—18° in the screen at Bath and Oxford, 10° at Nottingham, 20° at Dover, and 22° at Dungeness.

IN the *Bulletin of the Italian Geographical Society* (1907, pp. 738-745) Prof. L. Palazzo, director of the Italian Meteorological Service, under the title "I brontidi del Bacino Bolenese," gives an interesting account of the mysterious phenomenon generally known as "mist-poeffers," or in English as barisal guns, from its occurrence in the delta of the Brahmaputra. The paper is compiled from reports supplied by persons living on the shores of the lake of Bolsena (Latium) and adjacent parts, and deals with the sonorous character of the phenomenon, its frequency, and the accompanying meteorological conditions. The sounds generally appear to come from the shores of the Tyrrhenian Sea, about twenty-four miles distant from the lake; the description of them agrees entirely with reports from other parts, and with the accounts published by Van den Broeck, Günther, and others. The paper contributes much information on the subject, but throws no additional light upon the physical cause of the phenomenon, whether the origin be aerial or subterranean (see *NATURE*, vol. lii., p. 650, and vol. liii., p. 4).

IN the *Proceedings of the American Antiquarian Society*, vol. xviii., Prof. A. L. Rotch makes a timely publication of Franklin's descriptions of the first balloon ascents. These interesting documents consist of five copy-press letters written to Sir J. Banks, P.R.S., in 1783, when Franklin was Minister to the French Court. One of them probably has never before been published; the others are little known, although printed, with some alterations, in the editions of Franklin's works by Bigelow in 1888 and Smyth in 1906. The first ascent was made from the Champ de Mars on August 27, 1783; the balloon was filled with hydrogen, and was capable of lifting a weight of 30 lb.; about 50,000 people assembled to see the experiment. The second ascent was a hot-air balloon from Versailles, apparently in September; it carried a sheep and some poultry. The first and second manned balloons ascended on November 20 and December 1, 1783, filled with hot air kept up by burning straw and by "inflammable air" respectively; both experiments were successful. Referring to the first manned ascent, Franklin

wrote:—"I am sorry this Experiment is totally neglected in England where mechanic Genius is so strong. . . . Your Philosophy seems to be too bashful. . . . This Experience is by no means a trifling one. It may be attended with important Consequences that no one can foresee."

THE most noteworthy article in the Journal of the Franklin Institute for December, 1907, is that by Prof. J. W. Richards reviewing the progress made in the electro-thermic production of iron and steel. There is also a paper by Mr. E. S. Cole describing the pitometer, an ingenious instrument for measuring the leakage of water in mains.

THE current issue of the *Central*, the organ of the Central Technical College Old Students' Association, contains as a frontispiece an excellent portrait of Prof. W. E. Dalby. There is also an article by Prof. H. E. Armstrong on the nature of chemical change, in which he reviews the excellent research work accomplished by the chemical department of the college since 1885.

At a meeting of the Association of Engineers in Charge held in London on December 11, 1907, Mr. L. Gaster read a paper on the province of the illuminating engineer, in which he directed attention to the waste which is going on in the conversion of energy into light, and to the utilisation of the illuminants so as to produce the best illumination. He suggested a method for reducing the existing waste, and indicated some of the important problems with which the illuminating engineer has to deal.

A BATCH of publications received from the Department of Mines of Queensland affords striking evidence of the excellent work that is being done by the Geological Survey in investigating the mineral resources of the colony. Mr. B. Dunstan (Publication No. 207) describes some copper, gold, and bismuth mines in the Burnett district, west of Maryborough. Mr. L. C. Ball (No. 208) gives a careful report on the Norton goldfield, where gold was discovered in 1871, the total yield since then having amounted to 16,630 ounces. The reefs have hitherto been worked for their gold and silver contents, and the returns would, but for the complex sulphides in the ore, have given a profit. If a suitable method of treating these sulphides were adopted, many reefs hitherto neglected would probably be opened up. Mr. W. E. Cameron (No. 209) describes some goldfields of the Cape York Peninsula. The same author (No. 210) gives an exhaustive account, illustrated by a map and fourteen admirable plates, of the Annan River tinfield, Cooktown district. He shows that rich alluvial tin occurs at numerous points over an area twelve miles long by eight miles broad. Recently, hydraulicing the face with water under pressure has been adopted, and an attempt has been made to deal with the deposits by machinery by dredging the alluvial flats. Mr. B. Dunstan (No. 211) describes the Stanhills tinfields near Croydon, where recent operations have revealed ore of exceptionally rich quality, and the field has become very active. The tin is found in lodes and in alluvial deposits, and the area of the field amounts to about 100 square miles. Mr. B. Dunstan also publishes a further report (No. 212) on some Croydon gold-mines, with special reference to Bennion's reef and to the Highland Mary reef. Publication No. 213 is a map, on a scale of six miles to the inch, of the copper-mining district of Cloncurry, compiled by Mr. L. C. Ball.

To the Bulletin of the American Mathematical Society, xiii., 10, Prof. Cleveland Abbe contributes a short note on the possibility of studying the movements of the atmo-

sphere by laboratory experiments with projections of a globe. It being necessary to use flat models, the conditions are necessarily different from those on our earth, and the author discusses the projections of the sphere best suited for taking account of different effects.

THE Transactions of the American Mathematical Society (viii., 4) contain a paper by Prof. A. G. Greenhill, F.R.S., on the elliptic integral in electromagnetic theory. The investigation was undertaken during the lifetime of the late Principal Viriamu Jones, F.R.S., in connection with the calculation of the mutual attraction of two coaxial helices employed in the ampere balance designed by Principal Viriamu Jones and Prof. Ayrton. The object is to exhibit the third complete elliptic integral in the form most suitable for computation.

IN the *Revue générale des Sciences* (November 30, 1907) M. Th. Reinach publishes, with an introduction by Prof. Painlevé, a translation of the manuscript of Archimedes discovered in 1899 by Papadopoulos Kerameus on a palimpsest parchment. This manuscript soon attracted the attention of Profs. H. Schoene and Heiberg, and the latter visited Constantinople in 1906 to study the precious document. It consists of four parts, some containing works already known, and the present article deals with the fourth, namely, the treatise on method (Ephodos), which is dedicated to Eratosthenes. It deals with the quadrature of a parabola, and with the volumes and centres of gravity of spheres, ellipsoids, paraboloids and hyperboloids of revolution, and the "method of exhaustion" adopted by Archimedes distinctly anticipates its modern equivalent of integration. A further interesting feature of the problem is Archimedes' use of the principle of the lever in comparing different solids of revolution by a kind of method of balancing the elements of one against the corresponding elements of the other.

IN the *Verhandlungen der deutschen physikalischen Gesellschaft* for November 30, 1907, Drs. U. Behn and H. Geiger give 1.63 as the result of their determination of the ratio of the specific heats of helium at constant pressure and at constant volume respectively. Their method is a modification of Kundt's. The tube containing the gas is sealed at both ends, and is clamped in the middle. Its frequency for longitudinal oscillations is adjusted by attaching metal discs to the ends with sealing wax, until the lycopodium within is set in motion by the resonance of the gas. One end of the helium tube projects in the usual way into a second tube containing air, and produces dust figures in the air from which the frequency of the oscillation is calculated.

PART VII. of vol. xxi. of the Journal of the College of Science of the University of Tokyo consists of an account of the work done by Messrs. K. Honda and T. Terada on the reciprocal relations of stress and magnetisation in a number of irons and steels. The specimens, in the form of wires, were magnetised under tension in a vertical magnetising coil, and the induction was measured ballistically both, with change of stress at constant field and with change of field at constant stress. The result is a verification of the theories of Prof. J. J. Thomson and others so far as the principal effects are concerned, but hysteresis effects appear to make it impossible to test experimentally the correctness of the terms of the second order, in which the theories differ from each other.

A MEMOIR by Miss E. M. Elderton, Galton research scholar in national eugenics of the University of London, assisted by Prof. Karl Pearson, on the resemblance between first cousins, has been issued by Messrs. Dulau and Co. The memoir gives the results of two series of investiga-

tions, the first dealing mainly with qualitative characters—such as health, ability, temper, temperament, and success in life—the second, not yet completed, with certain measurements on the hand, eye-colour and hair-colour, as well as health.

In the current number of *Science Progress*, published by Mr. John Murray at five shillings net, there are several articles of interest on applied science. In the first place we notice a paper by Dr. J. S. Haldane, F.R.S., on work under pressure and in great heat, giving a very good *précis* of the author's researches in this department, which have altered the Admiralty practice as regards diving, and should alter the factory-mining regulations, when these well-meant rules are inspired by knowledge as well as good intention. The article by Dr. F. H. A. Marshall, on nutrition and fertility, touches on matters of great importance to breeders of stock, and furnishes a curious (and unintentional) commentary on the work of Prof. Chittenden on the minimum of food-stuffs. Articles that also call for mention are those of Prof. Halliburton on the repair of a nerve, and Mr. A. D. Darbishire on Mendelism. A fine portrait of the late Lord Kelvin appears as frontispiece.

AMONG the subjects of lantern-slides from photographic negatives, in the supplementary list just issued by Messrs. Newton and Co., are:—steel-making, showing operations at a great steel-works; coal-mining; wild life; pathological tissues; animal life in earlier times; eruption of Vesuvius in 1906; bacteriology of tropical diseases; and colour photography. The slides should be of real service in illustrating popular lectures upon scientific subjects.

THE old students of the Finsbury Technical College are to be congratulated on the first number of the magazine produced and published by their association. The cover of the magazine carries a medallion portrait of the principal of the college, Prof. Silvanus P. Thompson, F.R.S., and a portrait of the first president, Dr. M. O. Forster, F.R.S., forms a supplement. The reading matter includes a greeting from Prof. J. Perry, F.R.S., in which he refers to reformed methods of teaching mathematics and physical science.

THE tenth issue, that for 1908, of "Wellcome's Photographic Exposure Record and Diary," will prove of assistance to photographers. Much useful guidance is provided, and the mechanical calculator attached to the cover will be found serviceable. In addition to a complete diary for 1908, the book also contains tables for interior work, telephotography, copying, enlarging and reducing, moving objects, night photography, and for printing by artificial light. Three editions, adapted respectively to the conditions of various latitudes, are published, and the price of the volume is one shilling.

WE have received a copy of the first number of a new monthly technical magazine entitled the *Illuminating Engineer*, which is to be devoted to the subject of scientific illumination. The periodical is edited by Mr. Leon Gaster, and the price of each issue will be 1s. The first number, which runs to eighty-eight pages, contains a variety of articles and notes, some of which are well illustrated. Prof. J. A. Fleming, F.R.S., describes vacuum tube electric lighting; Dr. C. V. Drysdale deals with the production and utilisation of light; Mr. A. P. Trotter discusses the distribution and measurement of illumination; and Dr. Hugo Krüss gives an account of some researches on reflected transmitted light. The new periodical should appeal to all engineers concerned with illumination.

NO. 1994, VOL. 77]

OUR ASTRONOMICAL COLUMN.

COMETS DUE TO RETURN THIS YEAR.—In No. 392 of the *Observatory* (January), Mr. W. T. Lynn publishes a number of particulars concerning the periodical comets due to return during the present year. The first named is that discovered by M. Giacobini in December, 1900, and found to have a seven-year period.

The comet discovered by Mr. Denning on October 4, 1881, has, according to the calculated elements, a period of 8.8 years. In 1890 and in 1898-9 its position was not favourable for observation, so there is a likelihood of its being re-discovered in the early part of this year.

Encke's comet has been observed at every return since it was recognised as a periodic comet in 1819, and has already been found by Prof. Max Wolf. The comet discovered by Tempel in 1869 November 27, and recognised as periodical by Swift in 1880, should reappear during the coming summer; its period was found to be a little greater than $5\frac{1}{2}$ years. It was not seen in 1903, when it was last due, or in the preceding return of 1897, but was well observed in 1891.

DETERMINATION OF THE MOON'S LIGHT WITH A SELENIUM PHOTOMETER.—Some interesting results, accruing from preliminary experiments on the determination of the amount of light received from the moon at different phases, by means of selenium cells, are published in the December (1907) number of the *Astrophysical Journal* (vol. xxvii., No. 5, p. 326) by Messrs. J. Stebbins and F. C. Brown.

The moonlight was compared with the light of a standard candle burning under known conditions, the values obtained being subsequently reduced by correcting for atmospheric absorption, &c. For the light given out by the full moon the observers derived a value of 0.209 candle-power, but other cells employed gave different values, the mean value being very near to the 0.23 candle-power adopted by Müller as the mean obtained from visual observations.

The results show that at full moon we receive about nine times as much light as at half moon, and they also indicate that the moon is brighter between first quarter and full than in the corresponding phase after full moon. Observations made during the partial lunar eclipse of July 24, 1907, gave the instant of least light as 10h. 23m., whilst according to the *American Ephemeris* it was 10h. 24m.

The differences obtained by using different cells are probably due to the fact that the cells are not equally colour-sensitive, and to this point the authors propose to pay considerable attention; presumably the question of colour would not enter into the determination of the values at various phases when the same cell was employed throughout.

THE APPEARANCE OF NEPTUNE IN SMALL TELESCOPES.—A paper recently communicated by Mr. Holmes to the British Astronomical Association gave rise to an interesting discussion at the November (1907) meeting. The question discussed was the planetary appearance of Neptune in small telescopes, and whilst some of the members averred that it was difficult to recognise the disc with a 6-inch telescope, others, including Mr. Maw, stated that they had found such an instrument sufficiently large for this observation. The general result of the discussion appears to have been the conclusion that some of the earlier descriptions of the size and brightness of the disc of Neptune are misleading, although the form should be clearly recognised with an instrument of equivalent power to a 6-inch achromatic telescope (the *Observatory*, No. 392, p. 47).

THE "ANNUAIRE ASTRONOMIQUE" FOR 1908.—The excellent year-book of astronomy and meteorology issued by M. Flammarion is one of the most useful of its type and price to the amateur astronomer who reads French. It contains practically all the data he is likely to require in his work, besides a valuable annual review of the progress of astronomy. Many of the notes and directions are illustrated, and, in addition to the diary giving the astronomical phenomena for each day of the current year, there is a map of the sky for different times and dates in each month. The price of the volume is 1.50 francs.

SIMULTANEOUS OBSERVATIONS OF JUPITER.

IN the December *Bulletin de la Société astronomique de France* for 1905 (p. 556), readers who possessed telescopes were invited to collaborate in a scheme for the simultaneous observation of Jupiter on prearranged dates, and to make drawings and notes of what they saw, which were to be forwarded to a central authority for correlation and discussion.

The valuable results likely to accrue from such a combined attack are too obvious to need recapitulation, and when M. Nicolas Poutiata suggested the idea to M. Camille Flammarion, that indefatigable organiser transmitted it immediately to the French Astronomical Society, and asked for its cooperation. A scheme was drawn up, thirty-five observers in various parts of Europe responded to the invitation in the December *Bulletin*, and Dr. Jean Mascart undertook to discuss all the drawings and notes sent in. The present brochure collects his discussions, which have been appearing month by month in the *Bulletin*, and gives some valuable hints for any similar undertaking in the future.

Briefly, the programme arranged was as follows:—(1) Observers were to draw on prepared discs all the markings they were able to see on the planet's surface, at 20h. om. (8 p.m.) precisely (G.M.T. Paris), on every clear night from January 2-20, inclusive, 1906. (2) Arrangements were made so that observers residing in other longitudes than Paris should know the exact local time at which the observations were to be made, thus preventing any ambiguity as to the precise hour of observation. (3) Drawings were to be made on previously prepared white discs identical in size and shape, the scale being such that 1 mm. on the disc corresponds to about 2000 km. on the planet. (4) Detailed instructions were also given as to the preparation of fair copies of the drawings, their orientation, &c., and also as to the noting of any written details which would assist the general discussion.

The instruments employed varied in aperture from 75 mm. to 380 mm., and eye-pieces of various powers were used. The number of observations varied from five, on January 15, to seventeen, on January 14, and, altogether, 172 individual observations were made.

To illustrate the general character and variety of the drawings, we reproduce the set made on January 2, 1906. It is interesting to note that the personality of many of the individual observers appears throughout the entire series. Thus, for example, No. 4 here reproduced was made by Herr Phil. Fauth, who for twenty years has been training his eye to see finer and finer details on the moon's surface, and it is decidedly characteristic of all the drawings made by him in this series. The similarity of the drawings of this observer and those of Dom Amann, of Aosta, Italy, is a feature of each of the series where both occur, and the apertures and powers employed were practically the same in each case. No. 5 was drawn by the latter observer.

Dr. Mascart gives the notes made each day by each observer, and reproduces the drawings with numbers so that each may be identified, the latter being arranged, so far as possible, in the order of the instrumental aperture employed. Thus No. 1 in the above series was made by an observer using a telescope of 75 mm. aperture, No. 5 with a refractor of 170 mm., and No. 7 with a reflector of 195 mm. aperture made by the observer himself, M. Paul Vincart, of Antwerp, who thus demonstrates to his co-workers that, lacking the necessary wherewithal to

¹ "Observations simultanées de la Surface de Jupiter réunies." By M. Jean Mascart. Extrait du Bulletin de la Société astronomique de France (1907.)

purchase an instrument of serious size, a very good substitute may be made "par un peu de volonté et beaucoup d'huile de . . . biceps." Following the *seriatim* display of each day's notes, the author points out briefly the similarities and differences of the various drawings, directing particular attention to any striking peculiarity of any one of them.

These notes are too numerous to give in detail here, but it is safe to predict that they will amply repay the close study of every Jovian observer. The various undulations of the great southern equatorial band, the various tints of the polar regions, the fine rifts in the several bands, and many other features of interest, and of possible variation, are all recorded and commented upon. One item of more practical interest perhaps, illustrated, for example, in the drawings of January 5, is that the smaller apertures appear to give a greater relative intensity to the tints of the polar regions. Several curious globular structures, attached to the northern edge of the south equatorial band, and some *striae* in the north polar regions were recorded by Señor J. Comas Sola, using the 380 mm.

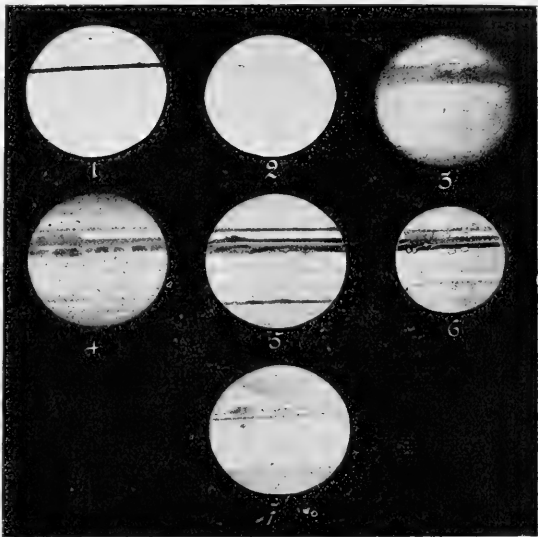

The Planet Jupiter: simultaneous drawing made by different observers, January 2, 1906.

Mailhat equatorial, on January 12. The seventeen drawings of January 14 form the most extensive and most valuable series, of which the various features provide plenty of material for a detailed study; one unique feature is the delineation of the south tropical band by M. Crouzel, who used the 380 mm. equatorial of the Toulouse Observatory, and shows this band as a chain-like series of loops.

When the January campaign was ended, several observers expressed the desire to continue, but it was found that the notice was too brief to organise the matter effectively. Nevertheless, some of the observers did continue, and valuable results, which Dr. Mascart discusses, were obtained.

An attempt was made by M. Blum, at Dr. Mascart's request, to obtain photographs showing the combined results of each day's work. The methods employed are fully described in the paper, and some reproductions of the combined photograph for January 8, obtained by different methods of exposure, &c., are shown, and seem to give excellent promise.

In conclusion, Dr. Mascart points out that perhaps the most valuable result of the recent attack is the experience gained, and he emphasises the details in the programme which need greater attention, such as the closer observation of the precise prearranged hour, the correct orientation of the final drawing, the care which should be exercised in confirming the presence of a faint marking before showing it on the drawing, and so on. Finally, he gives, with full detail, descriptions of various objectives and eye-pieces, showing in each case, by means of diagrams, their action on rays of light.

Taken as a whole, this preliminary campaign appears to have provided very valuable results, and it is to be hoped that future similar organisations will be guided by the experience now gained.

W. E. R.

THE NEW SCHOOL OF BOTANY, TRINITY COLLEGE, DUBLIN.

THE science schools committee of Trinity College, Dublin, is to be congratulated on the completion of the second item in its scheme for the scientific development of Trinity College. This project, which was in the first instance originated by Prof. John Joly, F.R.S., and has since owed much to his activity and devotion, was inaugurated in 1901 by a handsome subscription from the chancellor, the Earl of Rosse. At an early stage in the movement success was assured by a munificent gift from

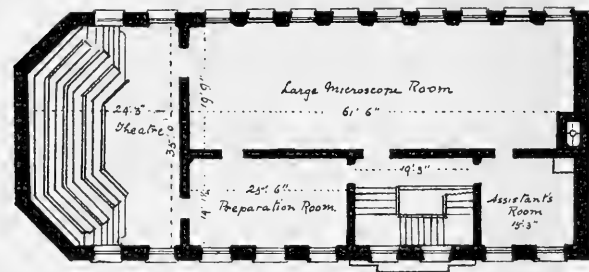

First Floor Plan.

Viscount Iveagh. According to the terms of this gift, Lord Iveagh undertook to build those departments for which the friends of Trinity College subscribed a capital sum requisite to yield the annual upkeep. Last year the School of Physics was completed, and at the beginning of the present session the School of Botany, the second department which has been benefited by this movement, was opened for work.

The School of Botany is a two-storied building of cut granite, situated in the east end of the college park, and lies east and west. This orientation gives a large number of windows facing north, with the best light for microscopic work. The western end, being octagonal, is occupied by a lecture theatre in the upper storey, on the ground floor by a very fine laboratory for general physiology. The northern side of the upper storey is occupied by a large microscope room, which can accommodate about sixty students working simultaneously. Through a large double door in the west end of this room access is obtained to the theatre. The auditorium in the latter is octagonal, so that every seat is close to the lecture table.

On the ground floor on the north side is a room for microscopic research, a library, professor's laboratory, and a laboratory for general physiology, which also forms the east end of the building. A solidly built greenhouse running out on the north side of the building is immediately connected with the physiological laboratory; on the south side of the latter opens a chemical laboratory. In addition to the usual fittings in the physiological laboratory, there

is a large dark chamber, constructed like a fume cupboard, in which plants may be grown in complete darkness, or illuminated by light transmitted through special filters. The greenhouse has a separate heating system from the rest of the building, and a centrally placed case in it may be heated by a special radiator to a higher temperature than the rest of the greenhouse. Much thought has been given to the working out of the plan and fittings of this new school, and as it stands the School of Botany in Trinity College must rank with the best in the British Isles. The architect was Mr. Wm. C. Marshall, of London, who also designed the Botanical Laboratory in Cambridge.

ON THE COLOURING MATTERS OF FLOWERS.

THIRTY or forty years ago I devoted much attention to the colouring matters in plants, studying them with my newly invented spectrum microscope. I published a few papers on particular branches of the subject, but there are other very wide questions the importance of which I did not perceive until altered circumstances led me to devote my attention to work out at sea. Amongst other things studied was the variation in the colour of flowers, which is manifestly a very extensive subject, and for which I had only limited opportunity to obtain the requisite material, having to rely to a great extent on wild plants and flowers in my garden. Though the results are incomplete, they are probably characteristic; and it may be well to publish them, since it is now impossible for me to complete them, and what I did will at all events serve to show what might be done. The whole subject is very complex in more ways than one.

The colouring matters of plants may be divided into two divisions, viz. those soluble in water but insoluble in carbon bisulphide or benzol, and those soluble in the latter reagents but not in water. Both are soluble in hydrous alcohol of the usual strength. Nearly all the blues and purples belong to the former, and most of the yellow and orange to the latter.

I found the best way of dealing with the flowers was to boil the petals or other portions in the usual hydrous alcohol, which dissolves both groups of pigments, and after evaporating to dryness, to re-dissolve the constituents in water, filter, and finally evaporate to dryness in a small saucer, in which, if kept fairly dry, the pigment will remain unchanged for a considerable time. Some pigments may be kept unchanged for a long time in a concentrated solution of lump sugar.

When re-dissolved in water many of the colouring matters soon become pale or nearly colourless, but recover their colour when evaporated to dryness. I never saw proof of this in living flowers, but it may occur when they die and fade. If there be any colour insoluble in water, it may be dissolved in carbon bisulphide, but this is seldom the case in blue, red, or purple flowers.

In those cases where the predominant colour is insoluble in water, it may be separated by agitating the alcoholic solution with carbon bisulphide, adding a little water. The bisulphide carries down the pigment in solution, which may then be evaporated to dryness in a small saucer and kept. When dissolved in alcohol or carbon bisulphide the colour fades more or less quickly, especially in the light, but if sealed up almost absolutely free from air, it will remain unchanged for many years, at all events in the dark.

Having, then, obtained the pigment in a fit state, the next thing is to examine it when in appropriate solution, either in its natural state or after the addition of a suitable reagent. To enter into full detail would make this paper far too long, but it seems desirable to give some particulars in order to show how the various pigments can be distinguished. Speaking generally, this is by their

optical properties, occasionally by the fluorescence, but usually by the absorption, as studied by a spectrum microscope, and whenever possible by the position of absorption bands under identical known conditions. This latter is very important, since their position may vary considerably with the character of the solution. I never attempted to obtain the pigments pure, in a state fit for chemical analysis, so as to determine their chemical composition.

The number of distinctly different colouring matters in flowers must be very great, and to study them completely would occupy a long time. The distribution of the different kinds is sometimes very definite, but often the reverse. In the genus *Hypericum* are sometimes small dark spots in the petals, and sometimes small dark rounded bodies are attached to the sepals. These are coloured by a pigment which gives a spectrum with narrow, well-marked absorption bands, which could not be mistaken for any other. This occurs in all the species I examined, but in no other flowers. On the contrary, there is a blue pigment, giving a sufficiently well-marked spectrum with several absorption bands, met with in many flowers separated about as much as possible botanically.

Much may be learned by the use of reagents. Vegetable pigments may be divided into three groups by the action of sodium sulphide, which I called Groups A, B, and C. Group A is at once made nearly or quite colourless by the addition of a small quantity of this salt. Group B is not at all altered when alkaline or neutral, but is at once made nearly colourless when acid. Group C is not changed even when acid. When made colourless the pigments are not permanently decomposed, but recover their colour when evaporated to dryness. I do not fully understand the cause of these effects.

Then, again, much may be learned from the action of citric acid and a weak alkali. The colour and spectra of many reds, purples, and blues are very different in acid, neutral, or alkaline solution. Some yellow pigments are made thirty times more intense by an alkali, whilst others are unchanged. As a rule, none of the above changes is due to a permanent alteration, but in some cases it is useful to employ stronger reagents, which decompose the natural pigments, such as nitrite of soda with the addition of a little citric acid. As an example I may cite the pigment of the common yellow garden crocus. This gives a strongly fluorescent yellow substance, unlike that produced in the case of any other flower I have examined. The only objection to such powerful reagents is that they may produce highly coloured substances from colourless bodies in the plant, and not merely alter the coloured constituent. As an interesting example I may name a deep red substance produced in the case of the different species of geranium examined, but not in the case of any other plant.

My remarks so far apply only to colouring matters soluble in water. Orange, orange-yellow, and lemon-yellow flowers are in most cases coloured by one or other of the four yellow pigments met with in green leaves, or by various mixtures of them, which are distinguished by the absence or presence of two absorption bands. These vary considerably in position according to the nature of the solvent, lying much nearer the red end of the spectrum when the pigment is dissolved in carbon bisulphide than when in benzol or alcohol. These absorption bands can also be seen in the spectra of the flowers themselves, and for some time I was unable to understand why in the case of *Chelidonium majus* they lay materially nearer the red end than in nearly all other yellow flowers which gave the same spectrum when the pigment was in solution, until I came to the conclusion that in *Chelidonium* it occurs in a free state, and not dissolved in oil or wax. There are other cases in plants where the spectra show that the pigments exist in a solid state, which would explain slight differences in tint.

We may now consider facts very common in cultivated plants, viz. a great variety of colours. In many cases this is easily explained, because we can see that two pigments exist, either alone or mixed in various proportions, one frequently being a yellow insoluble in water, and the other a blue or red soluble in it. As an example, I refer to the common wallflower of our gardens (*Calendula vulgaris*), which is sometimes a clear yellow, sometimes

a sort of crimson, but more commonly a crimson brown. The yellow is a xanthophyll soluble in carbon bisulphide; the crimson is a pigment soluble in water; the common colour is a mixture of these two, and gives the same spectrum as a yellow and a purple petal combined. We have a similar case in chrysanthemums and various other flowers. The common garden marigold is sometimes a pure yellow and sometimes a true orange or an intermediate tint, which is due to two different pigments alone or variously mixed. One or other of these may occur separate in different parts of the same flower in some plants.

In some flowers we find a considerable variety of tints, probably due to another cause. The common bedding geraniums of our gardens are a good example of this. At one time I thought that such varying tints might be due to varying acidity, but did not obtain satisfactory proofs, though it may be true in some cases. I, however, studied several closely allied pigments from other plants, and found that they seemed to agree in nearly every particular, except that the absorption bands in the spectra were not exactly in the same place. An excellent example of this kind is the red pigment of blood, giving two very well-defined absorption bands, which differ in position if the oxygen is replaced by carbonic oxide or nitrous oxide. Also the red pigment found in many birds' eggs, which I named oorhodeine, gives precisely the same remarkable and well-marked spectrum as the product of the action of strong sulphuric acid on the red pigment of blood, except that the position of the absorption bands differs distinctly. My suggested explanation of the difference in the colour and spectra of a number of the pigments in flowers is that some fundamental constituent is the same, but modified by some varying substance in combination.

A few flowers contain pigments which give spectra with unusually well-marked absorption bands. As remarkable examples I may mention the crimson *Cineraria* and the deep blue *Lobelia* of our gardens. The spectra are of almost exactly the same character, having two dark absorption bands, only they occur at a different part of the spectrum. I am unable to say whether this shows any relationship between the pigments, but the difference in the position of the bands is perhaps too great.

It will thus be seen that a very great number of distinct pigments are found in flowers, sometimes having a very restricted distribution, and sometimes the reverse. Then, again, the plant may be able to form two or more quite distinct colouring matters, either alone or mixed in varying proportions. In some cases the pigments seem to be easily subject to change, as though some constituent could be substituted for another. In one way or another there is thus great scope for variation, perhaps not brought into play, or only to a limited extent, in wild plants, but sometimes to a remarkable extent by cultivation.

H. C. SORBY.

UNIVERSITY AND EDUCATIONAL INTELLIGENCE.

CAMBRIDGE.—The Vice-Chancellor has received a letter from Baron von Hugel, curator of the Museum of General and Local Archaeology and of Ethnology, recording a gift from the Rev. John Roscoe, of the Church Missionary Society, of exceptional value and interest. It consists of a second instalment of selected native manufactures from Uganda. The chief value of the gift lies in a unique set of relics of deceased Baganda kings, which, enclosed in ornate cases, were preserved by the people under the name of Lubare (i.e. the Deity) in special shrines placed under the guardianship of hereditary custodians. Of these king-gods, the most sacred objects of Baganda cult, three generations are represented in the present collection.

With the first Roscoe collection, which was supplemented by a valuable gift of objects from the Katikiro of Uganda, the University acquired Kibuka, the war god of the Baganda, who with all his appurtenances was safely unearched from his ruined shrine in the Mawokota district. In this deity, as in the Lubare, personal relics form the essentials, and in Kibuka are enshrined the jaw-bone, &c.,

of the deified chief of that name, a renowned fighter who lived in the reign of Nakibinge, the eleventh king of the Baganda.

Objects such as these are not readily to be obtained; indeed, it required years of careful investigation and all the knowledge and experience gained in the field by this veteran missionary to negotiate their safe removal from the ancient shrines of Uganda to the show-cases of the University museum.

MANCHESTER.—Daily observations at the meteorological Observatory of the University at Glossop Moor are now being taken with kites or captive balloons, and preliminary records of the results are being published every day in the *Daily Telegraph* and other papers. The work, which has been instituted by Prof. A. Schuster, F.R.S., is under the immediate direction of Mr. J. E. Petavel, F.R.S., assisted by the following staff:—Messrs. T. V. Pring and W. A. Harwood, and Miss Margaret White, voluntary assistants. The generous cooperation of the meteorological observatories at Buxton, Huddersfield, Stonyhurst, Sheffield, and Manchester will facilitate the working out of comparative results, in the subsequent utilisation of the observations, and should add greatly to the value of this investigation of the meteorology of the upper atmosphere.

At a dinner of the Bristol University College Colston Society on Tuesday, the president, Mr. G. A. Wills, stated that contributions towards a university for Bristol have in the past two years amounted to 40,000*l.* He also announced that his father, Mr. H. O. Wills, has promised 100,000*l.* towards the endowment of the university for Bristol and the west of England provided a charter be granted within two years.

The national importance of brain-power provided by universities, as well as sea-power obtained by a strong navy, was insisted upon by Sir Norman Lockyer in his presidential address to the British Association in 1903; and a comparison was made of the expenditure on higher education with that on battleships. Prof. Turner, of the University of Birmingham, speaking at Stourbridge on January 6 in connection with the Stourbridge and District Higher Education Committee, used similar illustrations in referring to the cost of technical education. He pointed out that the Birmingham University and other local colleges and universities obtain a total grant per annum of about 100,000*l.* Let this be compared with our naval expenditure, and it is found that to build one battleship of the *Dreadnought* type absorbs the whole of the funds allocated to the local universities for seventeen years. Battleships are a necessity, but the Army and Navy cannot exist apart from the nation's third line of defence—its internal manufactures—and these depend largely upon the rearing of an educated and skilled people.

The annual meeting of the Geographical Association was held on January 8. Mr. Douglas Freshfield, who presided, said that last year he had found it necessary to comment on the extraordinary decision of the Civil Service Commissioners to exclude geography from the examinations for the higher branches of the Civil Service, including the Foreign Office, but now he was able to congratulate the association upon a reversal of that decision. The report read supplied evidence that the association continues energetically its work of improving geographical instruction. Major Close delivered a lecture on map projection. It may be noticed that various lectures on the teaching of geography have been arranged by the association. The first will be delivered by Mr. G. G. Chisholm on January 24, at 8 p.m., at University College, and the second, on scientific method in the teaching of geography, by Prof. R. A. Gregory, on February 14 at the same place and time. The remaining lectures will be delivered on alternate Fridays upon the following subjects:—Physical geography as an essential part of school geography, Mr. T. Alford Smith; how to teach the geography of a country, Prof. L. W. Lyde; orographical maps as the basis of the geography lesson, Dr. A. J. Herbertson; and geographical laboratories, Mr. A. T. Simmons. Particulars may be obtained from Mr. J. F. Unstead, 5 Wiverton Road, Sydenham.

The issue of *Science* for December 20, 1907, contains the annual opening address delivered last October by Prof. F. F. Wesbrook, of the University of Minnesota, before the faculty of science of the University of Manitoba at Winnipeg. Discussing the needs of the Canadian university, Prof. Wesbrook instituted an interesting comparison between what is required in the direction of higher education in Manitoba and the similar needs of the University of Minnesota, which was founded nine years earlier than the Canadian institution. Although Manitoba has had a university since 1877, it cannot be said as yet to have made provision for it which is at all adequate. Manitoba has now a population of about 380,000, and with all the demand on her for increased university facilities has only been able to expend approximately 16,000*l.* for building and permanent improvement, and for maintenance 3000*l.* per annum (which until last year was only 1200*l.*), with an addition of 5000*l.* from land grant and other sources, making a total current expenditure of 8000*l.* per annum. In the case of Minnesota University, there were in 1887 only 412 students registered out of a State population of 1,180,000, and there was available 7000*l.* from State funds and a total of practically 14,000*l.* from all sources, with a total student attendance per ten thousand population of 3.49. In 1906 the population of the State had nearly doubled, the University attendance had increased to 3956, the total funds derived from the State to 50,300*l.* per annum, the total annual current expense of the University, exclusive of buildings and permanent improvements, was 108,400*l.* per annum, and the attendance at the University for each ten thousand of State population was twenty students. The total expenditure for maintenance, exclusive of State grants for hospital maintenance, special investigations, library expenses, repairs, and so on, will this year be above 132,600*l.* Well may Prof. Wesbrook urge the people of Manitoba to emulate the American example he cites. It is to be hoped that the approaching visit of the British Association to Winnipeg will assist the Canadian authorities in developing the University.

SOCIETIES AND ACADEMIES.

LONDON.

Royal Society, November 14, 1907.—"On the Cranial and Facial Characters of the Neandertal Race." By Prof. W. J. Sollas.

As a result of a comparison of the calvarium of the Neandertal race with that of the aborigines of South Australia, it is shown that a much closer resemblance exists than some authorities have supposed, especially as regards the calottal height, Schwalbe's ("bregma") angle, and the bregma index. The chief differences are to be found in the cephalic index, the continuity of the frontal torus, and the deeply impressed character of the frontal fossa.

Comparisons based on the glabella-inion line are misleading, owing to the inconstancy in position of the inion.

The exterior foramino-basal angle owes its perplexing anomalies to the fact that its magnitude is determined by five variables, one of which is connected with the cranial height, so that in depressed forms of skull it acquires a higher value than might otherwise be expected.

The Gibraltar skull is the only example of the Neandertal race which presents the bones of the face and the basi-cranial axis in undisturbed connection with the calvarium. Its characters, apart from the cranial vault, are unique; no other known skull possesses so long a face or such a large and broad nasal aperture. In profile, the nasal curve flows into that of the glabella, without any sudden change of flexure, that is, there is no nasal notch, such as occurs in the Australians.

The orbit, as in all skulls of the Neandertal race, is distinguished by its excessive height above a line drawn from the nasion to the middle of the fronto-zygomatic suture.

The sphenoidal angle has been measured from the limbus sphenoidalis by a line drawn to the crista galli on the one hand and the basion on the other; it exceeds the corresponding angle of the lowest known South Australian skull, similarly measured, by 16° 30'.

The palate is very dolicho-uranic. The thickness of the frontal bone, measured on one side of the crista galli, is 24 mm. The prognathism of the upper jaw, in whatever way measured, is extremely small, so that the skull must be classed as orthognathous.

The cranial capacity is estimated at 1250 c.c., a close approach to that of the Neanderthal calotte. The average capacity of South Australian skulls is very similar, but ranges from 1460 c.c. to 1100 c.c. If the calotte of *Pithecanthropus* represents the mean of a similarly variable race, then the extreme forms of such a race would almost completely bridge over the hiatus between man and the higher apes.

Society of Chemical Industry, January 6.—Dr. J. Lewkowitch in the chair.—Some observations on the keeping power of Fehling's solution, together with notes on the volumetric process of determining reducing sugars with it: Dr. Francis Watts and H. A. Tempary. The authors point out that, contrary to the commonly expressed idea, Fehling's solution, or at least Violette's modification of it, is not liable to deteriorate rapidly if kept in the dark, and if access of air is prevented. The solution can thus be kept mixed ready for use for many months, and it is not necessary to keep the stock in the form of two solutions to be mixed as required.—The determinations of small quantities of bismuth: H. W. Rowell. Methods of separation suitable for ores, copper, and base bullion are given which eventually precipitate the bismuth, together with various impurities which do not affect the subsequent colorimetric estimation, but aid in the collection of the bismuth. The colour test depends upon the solubility of bismuth iodide in excess of potassium iodide producing a yellow colour. The test is very delicate, and the amount of bismuth in copper or base bullion may be determined within five hours.

Mathematical Society, January 9.—Prof. W. Burnside, president, in the chair.—The distinctive character of Lord Kelvin's mathematical investigations: Prof. A. E. H. Love.—A formula of interpolation: C. S. Jackson.—Hilbert's invariant integral in the calculus of variations: T. J. P. A. Bromwich.—An operator related to q -series: Rev. F. H. Jackson.

PARIS.

Academy of Sciences, January 6.—M. Henri Becquerel in the chair.—Report presented in the name of the section of geography and navigation concerning a subject put forward by the Geographical Society of Paris relating to meteorological telegrams from Iceland: Bouquet de la Grye.—The transformations of the comet 1907: Ernest Esclangon. The variations in the form of the comet on approaching perihelion were studied under very favourable conditions of weather and atmosphere, and are illustrated by six diagrams.—The use of flames as valves for alternating high-tension currents: André Cathiard. When two electrodes, one of which has a very small section compared to the other, are placed in a flame and in a high-tension (2000 volts to 10,000 volts) circuit, a small continuous current passes, a sort of faintly luminous arc being produced in the flame. In the experiments described, the frequency was forty per second, and a current was obtained, not exceeding 0.03 ampere, capable of producing galvanic deposits. The nature of the current has not yet been studied with the oscillograph.—Contribution to the study of the formation of certain precious stones of crystallised alumina: F. Boudas. Exposure to a temperature of 300° C. for a long time causes the yellow colour of both natural (Oriental topaz) and artificial yellow corundums to disappear. The Oriental emerald, a very rare stone, can be produced by starting with a sapphire-blue stone and subjecting it to the above temperature for a certain time. Further experiments with the cathode rays, analogous to the β -radiation rays, do not cause colourless corundums to pass to yellow, and the yellow stones are not affected.—The harmonics of a vibrating body: G. Sizes and G. Massol.—Some new homologues of diglycolic acid: E. Jungfleisch and M. Godchot.—The mechanism of the transpositions of the phenyl group in the iodohydrins and aromatic glycols: Marc Tiffeneau. Although the mechanism of the trans-

positions of iodohydrins of the type $\text{Ar}(\text{R})(\text{OH})\cdot\text{CHI}\cdot\text{R}$ is definitely established, the interpretation of the mechanism of the transpositions of the aromatic glycols by the formation of diethylene oxides can only be considered as provisional.—The structure of the fundamental substance of hyaline cartilage: Ed. Retterer. From the morphological and structural point of view, the fundamental substance of hyaline cartilage is identical with bone substance. It represents, in fact, only the second stage of evolution of the cytoplasm of the cartilaginous cell.—The development and structure of the spores of *Thelohania Giardi*: L. Mercier.—The existence of six branchial arches and six aortic arches in the embryo of the mole: A. Soulié and C. Bonne.—The fertilisation and development of the eggs in *Rhopalura ophiocoma*: Maurice Caullery and Alphonse Lavalée. The egg evolves into an embryo with perfectly individualised cells, and having none of the plasmodial structure of the ulterior parasitic stages. Ten figures of the egg in different stages of development accompany the paper.—Prolonged anaesthesia by mixtures of oxygen and ethyl chloride: Pierre Rosenthal and Albert Berthelot. The authors have been able to prolong the anaesthesia due to ethyl chloride by administering it mixed with oxygen. In experiments with animals, a true anaesthesia lasting an hour was obtained, the subject going under very rapidly, the narcosis quiet, and recovery prompt. They hope to be able to apply the method to human subjects, more especially as this anaesthetic has the great advantage of not causing the after effects of ether and chloroform.—The slow action of chlorinated products derived from bacilli: MM. Moussu and Goupil.—The value of the magnetic elements at the Observatory of Val-Joyeux on January 1, 1908: Th. Moureaux.—The study of a series of specimens of seawater collected in the English Channel: A. Chevallier. Determinations were made of the density, temperature at the time of collection, chlorine, and sulphuric acid. A curve is given showing the difference of density as ordinates, and the distance from Dieppe as abscissæ.

NEW SOUTH WALES.

Royal Society, October 2, 1907.—Mr. H. Deane, president, in the chair.—Law of meteorological phenomena: A. G. Williams.—A simple form of Sprengel vacuum pump: Prof. J. A. Pollock. A modified short-fall Sprengel vacuum pump of moderate dimensions is described, in which the raising of the mercury, necessary for continuous working, is effected by evaporating the mercury at a lower and condensing it at a higher level.—Note on the internal structure of some gold crystals: Prof. A. Liversidge. The author exhibited sections of isolated crystals and groups of gold crystals, mainly octahedra and rhombic dodecahedra, and photographs of the same before and after cutting. The simple faces on polishing and etching showed that the internal structure did not correspond with the external; e.g. in one case the rhombic planes of an externally simple dodecahedron were found to be made up of two triangular faces; on these triangles there were also faces of smaller crystals. Some showed a still more complex structure.

November 6, 1907.—Mr. H. A. Lenehan, vice-president, in the chair.—Notes on the Arranda tribe: R. H. Mathews.—A short, accurate method for the estimation of iron, alumina, and phosphoric acid when occurring together: Dr. T. Cooksey. When iron, alumina, and phosphoric acid occur together the iron is estimated by a volumetric process (as, for instance, by means of potassium iodide and thiosulphate of soda); the phosphates of the two metals are weighed, and the phosphoric acid in filtrate estimated, as previously described. These data are sufficient for the determination of all three quantities. The method is short and very accurate.—Note on the formation of formaldehyde in solutions of cane sugar, and its bearing on Hehner's test for formaldehyde in saccharine mixtures: A. A. Ramsay. The author directs attention to the production of formaldehyde when cane sugar and water are heated at a temperature below that at which caramelisation might take place. This fact explains how a reaction for formaldehyde by the Hehner test (which is one generally used, and particularly delicate) may be obtained from manufactured products

such as jams, sweetened condensed milk, or saccharine liquids, &c., and to which the manufacturer has added no formaldehyde, by the usual analytical operations of distilling a slightly acidified aqueous solution of the substance and testing the distillate, since the act of distilling a saccharine liquid results in the formation of formaldehyde.

Linnean Society, November 27, 1907.—Mr. J. H. Maiden, vice-president, in the chair.—The geology of the Nandewar Mountains, New South Wales: H. I. Jensen. The physiography and geology of the Nandewars offer points of similarity to those of the Warrumbungle Mountains. For example, the Nandewars present the features of arid erosion, and the level country to the west of them forms an arid-erosion peneplain. In late Palaeozoic times the present line of trachyte necks was practically a shore-line, with land to the west and sea to the east. By the end of the permo-Carboniferous period, the sea had given place to a fresh-water lake. In Triassic and Cretaceous times sedimentation took place west of this line, and erosion east of it. During late Mesozoic times the area of the Nandewar Mountains was reduced to a peneplain; basic localities were injected, and basic lavas flowed over parts. During early Tertiary times much faulting took place. Lavas escaped from the main fissure and from numerous cross-fractures. Tuffs, ashes, and breccias were ejected, and alkaline lavas solidified in their vents. Gradually more basic types of lava were emitted. In one respect the Nandewar Mountains differ from the Warrumbungles in that, in the Nandewars, sill-structure is represented on a grand scale.

DIARY OF SOCIETIES.

THURSDAY, JANUARY 16.

ROYAL SOCIETY, at 4.30.—Alternate Current Measurement: Dr. W. E. Sumner.—Prominence and Coronar Structure: Dr. W. J. S. Lockyer. The Conversion of Diamond into Coke in High Vacuum by Kathode Rays: Hon. C. A. Parsons, C.B., F.R.S., and A. A. Campbell Swinton. On the Perception of the Direction of Sound: Prof. C. S. Myers and Prof. H. A. Wilson, F.R.S.—Preliminary Note on Certain Phenomena of the Electric Discharge through Rarefied Nitrogen: Dr. G. J. Burch, F.R.S., J. E. Marsh, F.R.S., and R. de J. F. Strathern.

ROYAL INSTITUTION, at 3.—The Building of Britain: Prof. W. W. Watts, F.R.S.

INSTITUTION OF MINING AND METALLURGY, at 8.—The Vaal River Diamond Diggings: M. Park.—The Eruptive Diamond-bearing Breccias of the Boshof District, South Africa: J. P. Johnson.—The Auriferous Banded Ironstones and Associated Schists of South Africa: O. Letcher.

SOCIETY OF ARTS, at 4.30.—Indian Agriculture: Henry S. Lawrence.

LINNEAN SOCIETY, at 8.—(1) Brassica Crosses, illustrated by lantern slides: (2) Notes on Wild Types of Tubering Solanums, illustrated by lantern slides: A. W. Sutton.—Revision of the genus *Hylaria*, Blume: S. T. Dunn.—New Conifer of Formosa: Bunzo Hayata.

CHEMICAL SOCIETY, at 8.30.—Colour and Constitution of Azo-compounds. Part II. The Salts of β -Hydroxyazo-compounds with Mineral Acids: J. J. Fox and J. T. Hewitt.—The Oxidation of Aromatic Hydrocarbons by Metallic Oxides, Permanganates, and Chromates: F. D. Chattaway.—Studies in Fermentation. II. The Mechanism of Alcoholic Fermentation: A. Sator.—Organic Derivatives of Silicon. Part IV. The Sulphonation of Benzylhydropropylsilyl Oxide and of Benzylhydripropylsilyl Oxide: H. Marsden and F. S. Kipping.—The Formation and Reactions of Imino-compounds. Part VI. The Formation and Reactions of Hydrazine from α -Xylylenedinitrile: C. W. Moore and J. F. Thorpe.

FRIDAY, JANUARY 17.

ROYAL INSTITUTION, at 9.—The Centenary of Davy's Discovery of the Metals of the Alkalies: Prof. T. E. Thorpe, C.B., F.R.S.

INSTITUTION OF MECHANICAL ENGINEERS, at 8.—Third Report to the Gas-Engine Research Committee: Prof. W. L. Hurst.

INSTITUTION OF CIVIL ENGINEERS, at 8.—The Principles of Engineering Geology: Dr. Herbert Lapworth.

SATURDAY, JANUARY 18.

ROYAL INSTITUTION, at 3.—The Electrification of Railways: Prof. Gisbert Kapp.

MONDAY, JANUARY 20.

SOCIETY OF ARTS, at 8.—The Theory and Practice of Clock Making: H. H. Cunyngbame, C.B.

VICTORIA INSTITUTE, at 4.30.—Resemblances between Jewish Ideas and Customs and Those of India: C. T. H. Hendley.

TUESDAY, JANUARY 21.

ROYAL INSTITUTION, at 9.—The Internal Ear of Different Animals: Dr. Albert A. Gray.

ROYAL STATISTICAL SOCIETY, at 5.

MINEOLOGICAL SOCIETY, at 8.—On Zeolites from the Neighbourhood of Belfast: F. N. A. Fleischmann.—On Struvite and its Relation to Dimorphite: Dr. G. T. Prior and Dr. F. Zambonini.—Twin-structure: Dr. J. W. Evans.—On a Simple Method of Drawing Crystals of Calcite and other Rhombic Crystals, and of Deducing the Relations of their Symbols: Prof. W. J. Lewis.

INSTITUTION OF CIVIL ENGINEERS, at 8.—Experimental Investigations of the Stresses in Masonry Dams Subjected to Water Pressure: Sir J. W. Outley, K.C.I.E., and Dr. A. W. Brightmore.—Stresses in Dams: an Experimental Investigation by Means of India-Rubber Models: J. S. Wilson and W. Gore.—Stresses in Masonry Dams: E. P. Hill.

WEDNESDAY, JANUARY 22.

GEOLOGICAL SOCIETY, at 8.—The Origin of the Pillow-Lava near Port Isaac in Cornwall: Clement Reid, F.R.S., and Henry Dewey.—On Sub-division of the Chalk of Trimmingham (Norfolk): R. M. Brydone.

SOCIETY OF ARTS, at 8.—Siam and its People: H. Hillman.

THURSDAY, JANUARY 23.

ROYAL SOCIETY, at 4.30.—*Probable Papers*: Report on the Eruption of the Soufrière in St. Vincent in 1902, and on a Visit to Montagne Pelée in Martinique. Part II.: Dr. Tempest Anderson.—On the Intimate Structure of Crystals. Part VI., Titanic Oxide, its Polymorphs and Isomorphs: Prof. W. J. Sollas, F.R.S.—Dietetics in Tuberculosis. Principles and Economics: Dr. N. D. Bardwell and Dr. J. E. Chapman.—The Origin and Destiny of Cholesterol in the Animal Organism. Part I., On the so-called Hippocoprosterol: C. Dorée and Dr. J. A. Gardner.

ROYAL INSTITUTION, at 3.—Recent Light on Ancient Physiographies: Prof. W. W. Watts, F.R.S.

INSTITUTION OF ELECTRICAL ENGINEERS, at 8.—Standard Performance of Electrical Machinery: R. Goldschmidt.

FRIDAY, JANUARY 24.

ROYAL INSTITUTION, at 9.—The Extinction of Malta Fever: Col. David Bruce, C.B., F.R.S.

PHYSICAL SOCIETY, at 5.—Recalcescence Curves: W. Rosenhain.—An Experimental Examination of Gibbs' Theory of Surface Concentration Regarded as the Basis of Adsorption, and an Application to the Theory of Dyeing: W. C. M. Lewis.

INSTITUTION OF CIVIL ENGINEERS, at 8.—A Cost Theory of Reinforced-Concrete Beams: J. R. Wade.—The Neutral Axis in Reinforced-Concrete Beams: E. I. Spiers.

SATURDAY, JANUARY 25.

ROYAL INSTITUTION, at 3.—The Electrification of Railways: Prof. Gisbert Kapp.

MATHEMATICAL ASSOCIATION, at 2.30.—Address by the President, Prof. G. H. Bryan, F.R.S.—On the Teaching of Elementary Mechanics, with Special Reference to the Preparation and Use of Simple and Inexpensive Apparatus: W. J. Dobbs.—On the Teaching of the Elements of Analysis: C. O. Tuckey.—On the Geometrical Treatment of Series in Trigonometry, with Lantern Illustration: F. J. W. Whipple.—On a New Treatment of Similarity in Elementary Geometry: W. E. Bryan.—Machine for Drawing Rectangular Hyperbolas: H. L. Trautenberg.

CONTENTS.

	PAGE
The Cotton Plant. By F. Fletcher	241
A Concise Work on Evolution. By R. S	242
Studies in Education	243
Maintenance of Roads	244
Our Book Shelf:—	
Bauer: "A History of Chemistry"	244
Hubbard and Hubbard: "Neolithic Dew-ponds and Cattle-ways."	245
Biltz and Biltz: "Übungsbeispiele aus der anorganischen Experimentalchemie."	245
Partridge: "The Bacteriological Examination of Disinfectants."	246
Spengel: "Ergebnisse und Fortschritte der Zoologie."	246
Letters to the Editor:—	
Seismographs and Seismograms.—R. D. Oldham	246
An Early Acoustical Analogue of Michelson's Echelon Grating.—Prof. P. Zeeman	247
The Inheritance of "Acquired" Characters.—Rev. E. C. Spicer	247
The Diamantiferous Rock of Kimberley.—Prof. T. G. Bonney, F.R.S.	248
Musical Sand.—Prof. J. H. Poynting, F.R.S.; Sidney Skinner	248
Intensity of Spectrum Lines.—A. D. Cowper	248
Notes on Ancient British Monuments. IV. (Illustrated.) By Sir Norman Lockyer, K.C.B., F.R.S.	249
The Californian Earthquake of 1906. (Illustrated.)	251
Public Clocks and Time Distribution	253
Lord Kelvin and the Royal Society of Edinburgh	253
Notes	254
Our Astronomical Column:—	
Comets due to Return this Year	258
Determination of the Moon's Light with a Selenium Photometer	258
The Appearance of Neptune in Small Telescopes	258
The "Annuaire Astronomique" for 1908	258
Simultaneous Observations of Jupiter. (Illustrated.) By W. E. R.	259
The New School of Botany, Trinity College, Dublin. (With Diagram.)	260
On the Colouring Matters of Flowers. By Dr. H. C. Sorby, F.R.S.	260
University and Educational Intelligence	261
Societies and Academies	262
Diary of Societies	264

THURSDAY, JANUARY 23, 1908.

MANX ARCHÆOLOGY.

Manx Crosses; or the Inscribed and Sculptured Monuments of the Isle of Man from about the end of the Fifth to the beginning of the Thirteenth Century. By P. M. C. Kermodé. Pp. xxii+221. (London: Bemrose and Sons, Ltd., 1907.) Price 63s. net.

THIS handsome volume contains notes and illustrations of the inscribed and sculptured stones of the Isle of Man from the time of its conversion to the end of the Scandinavian rule, that is to say, from the close of the fifth (?) to the beginning of the thirteenth century A.D. The individual descriptions are preceded by some ninety pages on the early history of the island and the leading features of the monuments as a whole. These are of great value for the study of Celtic art in general, and many readers—all, indeed, who are unable to study the crosses on the spot—will give them more attention than the remainder of the book. In view of this fact and the somewhat recondite nature of the subject, it may not be out of place if we touch on the more important of their contents before proceeding to speak of particular instances.

The earliest monuments in the island are, without question, the rude boulders inscribed with Oghams. In language, formula, and characters these do not differ from those of the fifth century in Pagan Munster, but if we are to judge from the frequency with which the names of Irish ecclesiastics occur in the appellations of the Manx keels or chapels, and the dedications of the parish-churches, it seems reasonable to suppose that the Irish came to Man to christianise it, and that the Ogham writing was introduced by, and the stones erected to the memory of, Christians. The date of the conversion of the Celtic Manx is uncertain, but we know that it was in the sixth century that the Irish missionaries began to wander over Europe, and it would have been strange indeed if they had neglected a people so near at hand. The advance among them of the new creed, though never actually checked, was fated to be disturbed some three centuries later by the raids of the Vikings. They appeared in the Irish Sea in 798, and harried the island at intervals during a considerable period. At the end of the ninth or the beginning of the tenth century, it began to be definitely occupied by the Scandinavian invaders, and for the next hundred years it was ruled by the successors of Olaf the White, King of Dublin.

The Northmen, as we have said, did not attempt to stamp out Christianity among their Manx subjects; on the contrary, our author thinks it not unlikely that the Celtic church revived, and that the later Celtic pieces carved in relief and highly decorated were erected during this period. The conversion of the settlers themselves he shows ground for assigning to the first quarter of the eleventh century, and it is significant that after 1050 we hear of a Norwegian bishop, "Hroolwer or Hrolfr," who, according to the chronicle, was succeeded by another, William, before Godred Crovan began to reign in 1075. The year of Hroolwer's coming or death is unknown, but

this mention of him enables us to fix approximately the date of our first Scandinavian monuments, which cannot be earlier than 1025 or 1030, and as in one of his inscriptions (Kirk Michael 74) Gaut claims to have made all the crosses in Man, we must suppose enough time to have elapsed for the late Celtic pieces to have been overlooked. Yet neither from this nor from the appearance of the Norwegian ecclesiastics should we be justified in assuming a break in the continuity of the Celtic Church; that there was no such thing is shown by the fact that the later Scandinavian pieces preserve the Celtic type, and are found on ancient sites dedicated to Celtic saints. But if its ascendancy was undisputed by the Northmen it was fated to pass away before another power; the year 1170 saw the foundation of the Abbey of Rushen, and this resulted in the virtual subjection of the Manx hierarchy to the great English house of Furness. Under these new conditions the native school of art ceased to develop, the foreigners being opposed to anything savouring of paganism, such as the Runic inscriptions, or likely to interfere with the spread of Catholicism. The Gothic coffin-lid at Rushen may well have belonged to one of the last of the Scandinavian rulers. In any case it is unlikely that the specimens of Celtic art in the island are, any of them, later than the beginning of the thirteenth century.

From the circumstances of their production our author passes on to speak of their distribution and artistic features. As most of us are aware, they form part of the monumental system of the early British Church; which was an extension westward of that of Christian Rome in the period succeeding the death of Constantine. They will be found, however, to show distinct local peculiarities. Of the 116 pieces discussed in the book forty-five are classed as Scandinavian, seventy-one as of earlier date. Maughold has by far the greater number, thirty-seven; Michael comes next with ten, Braddan with nine. Both groups alike are of local rock, usually clay-slate, derived from the immediate neighbourhood. Almost all are sepulchral, and though described as crosses, they are, strictly speaking, cross-slabs, upright, rectangular blocks, varying from 2 feet 6 inches to 6 feet in height, by about fifteen to twenty-four inches wide, and from two to four inches thick. A few are wheel-headed or rounded; only in two late instances is the stone itself cruciform.

We are not surprised to find that the pre-Scandinavian monuments are more numerous in the old parishes Maughold, Braddan, Conchan, Rushen, Lonan and German. After the Ogham-stones already mentioned come a certain number with crosses incised, linear or in outline, all of them plain except for three with hexafoil and one with triquetra. A further stage is reached by those with the figure sculptured in relief. Of the stones of this group, seven show practically no decorative treatment, thirteen are plain or have decorations only of the simplest, cross-lets, pellets, bosses, &c., while the remaining eighteen have geometrical designs, zoomorphic interlacings, and figure subjects. These latter are hard to date exactly, but they clearly reached down to the period of the Scandinavian occupation if they did not overlap

it. We must not forget to mention, midway between the incised and decorated pieces, six monuments with sunk background or design.

These pre-Scandinavian crosses vary greatly in shape, particularly those of the earlier groups. Among those incised in outline we find some pure Latin, some equal-limbed, some with expanded arms, one crux ansata, &c. At first, at any rate, we are not confined to the type with recessed limbs and joined ends, which it is customary to associate with Celtic art, and which came to predominate here as in other Celtic countries. The art motives remind us, if anything, of those of the Irish school, but it would be a mistake to suppose that the Manx artists were slavish imitators of foreign models, Irish or otherwise. Some well-known designs, viz. the step, the key-fret, and the spiral, are feebly represented or altogether missing. Nor do we meet with the lacertine and bird-like figures with interlaced top-knots, tongues, tails and legs, which are regarded as Irish *par excellence*, the nearest approach being the dragon-plait on the fragment from Cardle (Maughold 60). On the other hand, these monuments boast a certain number of patterns, e.g. the double twist with diamond ring and the various developments of loop-plait, which cannot be matched elsewhere, and show originality of conception as well as technical skill.

Except at Maughold and Braddan, the Scandinavian monuments are most numerous where there are few or no Celtic, as at Andreas, Michael, and Jurby. A few pieces are unadorned—these are late, strange to say—the remainder are handsomely decorated on both fronts, sometimes even on the edges. As we have pointed out, this series is to all intents and purposes a continuation of the earlier one. The crosses are Celtic in form; the decorative treatment and the designs are of Celtic origin. For one feature, indeed, it is not indebted to any Celtic, or indeed any Christian, model; we allude, needless to say, to its inscriptions in Runes. These occur on twenty-six out of the total of forty-five stones, eighteen in the northern and eight in the southern district. All are Scandinavian, in the Norwegian tongue excepting, perhaps, that on Maughold 104, which Prof. Bugge believes to be in Swedish. The one Anglo-Saxon example occurs on a stone of the Celtic group.

A good deal of space is devoted to this subject, not only to the Runes of Man, but to runes in general, and we do not doubt that this section will prove of great value to the student. Though the designs on these monuments are based on Celtic types, it would be a mistake to imagine that the men who made them drew their inspiration from pieces already in the island. On the contrary, several of their patterns, the step, the divergent spiral, and the chevron, are entirely absent from the Celtic pieces. The tendril and the forms of link-twist introduced by Gaut, Mr. Kermodé believes to have been suggested by the carved stones of Scotland and the north of England; the other designs on these later pieces he derives from the Celtic MSS., basing his view on the frequent use of the triquetra and other local peculiarities. The origin of the figure-drawing is harder to determine. It is true that some of the stones have zoomorphic patterns of

Norse type, and scenes from Norse mythology. Yet for all that, these latter have no more in common with the drawings of Scandinavia proper, which are inferior and rare, or the Viking-pieces of the Lake-district, than with the rude efforts of the Welsh or the later Irish work. They have some affinities with the drawings on the stones of East Scotland, but what we find on them for the most part are original representations taken direct from nature. Generally speaking, these Scandinavian monuments show less regard for accuracy, a bolder treatment, and greater freedom than the earlier pieces.

It remains to say something as to individual crosses, no easy task when the space is so limited, and there is so much to detain the artist and antiquarian. We must be content to touch very briefly on a few of those most worthy of attention. Of the stones of the Celtic group a great number are interesting mainly for the light they shed on the development of the figure or the design; the most striking in itself, far more striking than the more highly decorated pieces, is the stone found in the Calf of Man (50) with a unique example of the Byzantine treatment of the Crucifixion. We have alluded more than once to the Ogham stones of the fifth century Irish type. To these must be added two monuments, not Celtic, by the way, but Scandinavian, inscribed with scholastic or Pictish Oghams. On one of these, the beautiful Mal Lumkun Cross (Michael 104), along with Runic legends we find one of the earliest instances of the Ogham alphabet. Of the Latin inscriptions, that on Maughold 48 is perhaps the most interesting, the Guriat to whom it refers being connected in all probability with Cynan, King of Gwynedd, whose daughter Ethil he may be supposed to have married. The Anglian Runes on Braddan 25 form the word "Blagkimon," a known Anglo-Saxon personal name.

Among the Scandinavian monuments the most remarkable beyond a doubt, though not always the best preserved, are those with Norse mythological scenes (Jurby 93, Malew 94, Andreas 95, Bride 97, &c.). The representations of Sigurd slaying the dragon Fafni, or Heimdal blowing his horn, of Vidar spearing the Wolf, show great vigour and originality.

We have endeavoured to give an idea, however imperfect, of the contents of this long and interesting volume. We have but little to offer by way of criticism. One thing strikes us, and that is that the author is not of those antiquarians who are for ever wrestling facts to support a theory. If anything, he is afraid of being thought dogmatic. In expressing his own opinions he is careful not to shut out possible alternatives. He agrees, for instance, with Mr. Romilly Allen in deriving the Celtic cross from the monogram of Constantine's dream; he points out, none the less, that it might well have been developed from a form similar to that of the lost cross at Braddan, with equal limbs and circles between them. So, too, in the chapter on runes already mentioned, he places at the disposal of the reader a complete *résumé* of all the views on the subject. Except for many repetitions the arrangement of the work is admirable, and the style, all things considered, unusually lucid. The erudition displayed in it is considerable, and the standard of accu-

racy a high one. Mr. Kermode may fairly claim to have bestowed on the student a lasting possession, and to have done for the Isle of Man what Dr. Anderson and the late Mr. Romilly Allen did for Scotland.

A word must be said in conclusion as to the plates, which greatly enhance the value of the work. They are taken, not from photographs, but from reduced copies, made with the greatest care, of full-sized drawings, founded on rubbings of the stones.

CHEMICAL AND PHYSICAL TABLES.

Van Nostrand's Chemical Annual, 1907. Edited by Dr. J. C. Olsen. Pp. x+496. (London: A. Constable and Co., Ltd., 1907.) Price 12s. 6d. net.

CHEMICAL and physical tables required by various kinds of chemists have been collected in this annual. Among the ninety-three tables it contains are five-figure logarithms, constants of the elements, some very complete tables of factors and their logarithms for the calculation of gas, volumetric and gravimetric analyses, constants of fats, oils and waxes, the more important constants (molecular weight, specific gravity, melting point, boiling point, solubility, crystalline form and colour) of some 4000 inorganic and 5000 organic compounds, specific gravities of solutions, vapour pressure, conversion, and heat of combustion tables. The remainder of the book is taken up with classified lists of the chemical papers and books published since the beginning of 1905, and an index.

This matter forms a volume which has been much needed, and will be most useful to all chemists. No pains have been spared to make many of the tables accurate and comprehensive, as, for example, the above-mentioned data for some 9000 compounds. The classified list of chemical papers, on account of its conciseness, should, if kept complete, be quite useful even to those who have the fuller abstracts of the Chemical and American Chemical Societies; the list of books will be even more valuable.

Unfortunately, references have been given only in a few cases to the original observers of the data used in the annual. In future editions such references should be made more complete. The following quantities are not defined:—electrical conductivities, specific heat of gases (whether C_p or C_v), and the various "constants" and "values" for oils, fats and waxes. To give Reichert-Meissl values without definition when two sets of values are current is confusing. The table of gas densities is quoted, unfortunately, from Landolt-Börnstein-Meyerhoffer Tabellen, where the densities are calculated on certain assumptions (clearly wrong in the light of the work of D. Berthelot, P. Guye, Lord Rayleigh and others) instead of being the observed densities; further, the values found by E. Morley for hydrogen and oxygen in his classic work are not given.

While laborious determinations are being made to improve the second decimal place of atomic weights, there are scarcely any other physico-chemical constants known to anything like the accuracy which atomic

weights now have. The energies of many of the workers on atomic weights might now with great advantage be turned to improving the accuracy of many other constants. Boiling points are an example of this; scarcely any are known to $0\cdot1$, and many current values for the same substance differ by whole degrees. The boiling points of organic substances in this book are from Beilstein, yet for five out of the six esters we have tried, the very careful determinations of Young and Thomas are not given.

We have detected few misprints; the logarithm of 2011 is incorrect. The value of the inch in millimetres is given to eight places, or to 10^{-9} cm.; this is less than the accepted value for the diameter of an atom, and the minimum length visible. The boiling point of helium is given as -267° ; we were not aware that it had been liquefied; Olszewski failed to do so by cooling it to a calculated temperature of -270° .

We know of no other tables of this kind in English which are so complete and so up to date as this annual. It is convenient in size, and clearly printed on good paper. The five-figure logarithms are the best arranged we have seen. T. H. L.

A NEW TEXT-BOOK OF PSYCHOLOGY.

Elements of Psychology. By Dr. S. H. Mellone and Margaret Drummond. Pp. xvi+483. (Edinburgh and London: W. Blackwood and Sons, 1907.) Price 5s. net.

THIS book is the joint work of two authors who are evidently well acquainted with the needs of the examinee, as well as those of the more genuine student of the science of psychology. It is therefore not surprising to find in the preface the statement that the book is intended as "a contribution to the teaching of psychology." Every stone of offence is carefully removed from the learner's path. Even the usual order of treatment is altered for his benefit. After a few introductory chapters on the method and subject-matter of the science, the student is brought face to face with the most essential characteristic of consciousness, viz. mental activity, and in its most pronounced form—volition. Not until the emotions and pleasure-pain have been treated with like fulness and concreteness do the authors descend to the conventional sequence of sensation, perception, &c. This order is determined by relative difficulty of introspection, the prominent complexes of mental life being taken before their more abstract elements.

It will thus be seen that the introspection standpoint is avowedly adopted as the fundamental one. Although the objective conditions of consciousness are by no means neglected, no attempt is made to develop that objective and functional view of mental life which is so popular in certain quarters at the present day, and, to the present writer's mind at least, seems so full of promise. The standard authorities—Ward, James, Stout, &c.—are closely followed, and to such good purpose that the book forms an excellent introduction to the study of these authorities them-

selves. A notable feature is the list of detailed references inserted at the end of each section.

Altogether, the book will be found admirably suited for its purpose, viz. to serve as a general text-book for pass examinations in the subject at a university, and will probably earn a well-deserved popularity. One is tempted, however, to look for something more in a text-book on such a science as psychology. The science is a comparatively new one, with an ever-broadening outlook, and a text-book such as we have before us might well be expected to extend or at least define this outlook by discussion of the most recent experimental results attained by psychologists, where they appear to involve important modification of theory. Yet we look in vain for any reference to the important experiments of Drs. Head and Rivers on cutaneous sensibility, or, again, to those of Prof. Sherrington on the relation between the two eyes in their response to intermittent light stimulations. A treatment of the latter would probably have reminded the authors likewise to discuss the general problem of psychical fusion, over which they preserve a disappointing silence. These are two instances out of several that might be quoted.

Objection might also be made to the method of treatment of the general psychophysical relation in the chapter headed "Mind and Brain." A more concrete and detailed discussion would have given greater relevance to the suspense of judgment therein advocated, or might even have opened up the prospect of a reconciliation of interactionism and parallelism on metaphysical lines. Not even a beginner is likely to be satisfied with a crude "either—or" in this case.

The book should be valuable alike to teachers and students, as being a compact, sound, and thorough statement of current views in psychology. W. B.

OUR BOOK SHELF.

Die Physik Roger Bacon's. By Sebastian Vogl. Pp. 106. (Erlangen: Junge und Sohn, 1906.)

In this dissertation, Dr. Vogl has collected a large number of interesting facts relating (i) to Roger Bacon's, or, as we commonly say, Bacon's, biography, his education and his friends and colleagues; (ii) the literature of the Greeks, Romans, and Arabs, from which he derived his physical ideas; and (iii) his physical works. As the result of this study, Dr. Vogl has given us a typical insight into the state of science in the thirteenth century. Bacon was born about the time that the Dominican and Franciscan orders were founded, and in these circumstances the position of a man who was far in advance of his times is not difficult to understand, especially in such an atmosphere as that of Oxford, where he remained until 1240.

As usually happens, Bacon's claims to fame can hardly be said to be well understood even at the present time. Dr. Vogl considers that no great importance can be attached to his predictions of steam engines, flying machines, and other modern inventions, all of which only reproduce ideas current in Arabic and other writings. On the other hand, Dr. Vogl considers Bacon has claims to be regarded as the founder of mathematical physics, and the large portion of the *opus majus* devoted to the uses of mathematics in science doubtless constitutes one of the most important advances with which Bacon was associated. His physical writings dealt mainly with optical problems, and this

is scarcely to be wondered at, for geometrical optics is the simplest and at the same time the most perfect branch of applied mathematics. When we remember the great hostility and apathy which exist at the present time against mathematicians in England (as exemplified by a remark on p. 49 of NATURE, November 21, 1907, if this is to be taken seriously), we cannot wonder that in an age of religious superstition and ignorance Bacon fared badly. Although seven hundred years have elapsed, the world has not yet realised the great extent to which ignorance of mathematics is responsible for human crime, poverty, and misery.

The Preservation of Infant Life. A Guide for Health Visitors. By Emilia Kanthack. Pp. iv+92. (London: H. K. Lewis, 136 Gower Street, W.C.) Price 1s. net.

THIS small book consists of six lectures which were delivered by Miss Kanthack to voluntary health visitors in St. Pancras. In the words of Dr. J. F. J. Sykes, the medical officer of health of that borough, who has written a short preface, it "may be strongly recommended to those who intend to undertake health visiting amongst the poor."

It would be difficult to conceive of the subject of the preservation of infant life being better presented to the class of audience to which Miss Kanthack had to address herself, and the lectures furnish evidence of a considerable study of her subject, together with a sound practical acquaintance with it. They will well serve as models for those who may have to address similarly constituted audiences, and they may be read with pleasure and profit alike, not only by every woman health visitor, but by every educated woman. The information is so happily expressed and tellingly presented that one lays down the book with the sincere wish that Miss Kanthack may give us more.

In her opinion, personal influence is the keynote of success in dealing with infantile mortality. She emphasises the fact that the baby is an entity long before it is born; therefore, to give it a good start the mother must be looked after during pregnancy. Speaking of the dangers of the artificial feeding of infants, she makes the following stricture:—"If one of the brute creation refused to suckle its young it would be thought a monstrous violation of nature, and yet a woman may evade this natural function and it arouses no comments."

Sanitation in Daily Life. By Ellen H. Richards. Pp. ix+82. (Boston: Whitcomb and Barrows, 1907.) Price 60 cents net.

It is now generally agreed that in every efficient school the pupils should receive instruction in the simple laws of personal hygiene and of public health. The short, bright chapters which this book contains on subjects like "the clean city," "the clean house," and "habits of cleanliness" should be of value to teachers, especially those in elementary schools, as indicating the possibility of explaining vitally important truths in a manner which can be understood by children. The illustrative experiments at the end of each section should be studied by teachers who give lessons on health.

Der neue Leitfaden. By L. M. de la Motte Tischbrock. Pp. x+126. (London: John Murray, 1907.) Price 2s. 6d.

A SATISFACTORY course for students—juvenile or adult—commencing the study of the German language is provided in this book. In addition to being grammatically and educationally sound, and of good literary quality, the volume contains many extracts on scientific subjects as exercises for reading and translation.

LETTERS TO THE EDITOR.

[The Editor does not hold himself responsible for opinions expressed by his correspondents. Neither can he undertake to return, or to correspond with the writers of, rejected manuscripts intended for this or any other part of NATURE. No notice is taken of anonymous communications.]

The Stresses in Masonry Dams.

IF Prof. E. Brown will refer again to my letter published in NATURE of January 2, he will see that I specifically stated that I did not question that in so far as the dam acted as a horizontal beam, the stresses \widehat{xx} and \widehat{zz} will be different in an actual dam and a slab dam. The real point is that Prof. Karl Pearson has said that, apart from any action of this kind, the stresses \widehat{xx} and \widehat{zz} in a slab dam and in an actual dam are widely different. Thus, on p. 11 of Pearson and Pollard's paper, he says Messrs. Wilson and Gore put the stress \widehat{yy} zero, and "hence the vertical and horizontal pressures they calculated have no direct application to real dams." He has since explained in *Engineering*, September 20, 1907, that he did not here refer to any action of the kind mentioned by Prof. Brown and by myself in my original letter to you, but that, apart from any action of this kind, the stresses \widehat{xx} and \widehat{zz} are entirely different in a slab dam and a long dam. Messrs. Wilson and Gore deduced the stresses for their slab by the equations

$$\widehat{xx} = \frac{E}{\left(1 - \frac{1}{m^2}\right)} \left(e_1 + \frac{e_2}{m}\right)$$

$$\widehat{zz} = \frac{E}{\left(1 - \frac{1}{m^2}\right)} \left(e_2 + \frac{e_1}{m}\right),$$

where E is Young's modulus, e_1 and e_2 the measured strains, and m Poisson's ratio. So far as I can see, these equations give correctly the stresses \widehat{xx} and \widehat{zz} for the slab, and if my reasoning in my previous letter to you is correct, these stresses will be unaltered when the slab forms part of a complete dam and is then exposed to stresses \widehat{yy} at right angles to the plane of the other two.

H. M. MARTIN.

83 St. James's Road, Croydon, January 10.

MAY I ask whether the interesting experiments on gelatin models of masonry dams, recorded in your issue for January 2, p. 209, do not ignore one factor on which the stability of actual dams is calculated largely to depend, namely, the weight of its materials?

This factor does not seem to be reproduced in the model, and I conceive that it may account for the rupture depicted on p. 210, which is hardly of a kind that one would expect to have to guard against in a real dam.

OLIVER LODGE.

MR. MARTIN in his letter to NATURE of January 2 cites the body stress-equations of elasticity

$$\left. \begin{aligned} \frac{\widehat{axx}}{dx} + \frac{\widehat{dxx}}{dz} &= 0 \\ \frac{\widehat{dxx}}{dx} + \frac{\widehat{dzz}}{dz} + p\gamma &= 0 \end{aligned} \right\} \dots \dots (i)$$

and appears entirely to overlook the fact that two equations will not suffice to determine the three stresses \widehat{xx} , \widehat{zz} , and \widehat{xz} . There is another relation between the stresses, and this relation depends on the relation between the strains, which is purely geometrical, namely,

$$\frac{\widehat{d^2\sigma_{xz}}}{dx^2} = \frac{\widehat{d^2\sigma_{xx}}}{dx^2} + \frac{\widehat{d^2\epsilon_{xz}}}{dx^2} \dots \dots (ii)$$

In substituting for these strains in terms of the stresses the resulting third equation differs for the cases of the dam and of the slab.

For the case of the dam abutting at its terminals against rigid supports:—

$$4 \frac{\widehat{d^2xz}}{dx^2} = 2\eta \left(\frac{\widehat{d^2}}{dx^2} + \frac{\widehat{d^2}}{dz^2} \right) (\widehat{xx} + \widehat{zz}) + \left(\frac{\widehat{d^2}}{dz^2} - \frac{\widehat{d^2}}{dx^2} \right) (\widehat{xx} - \widehat{zz}) \quad (iii)$$

For the slab with free faces:—

$$4 \frac{\widehat{d^2xz}}{dx^2} = \frac{1+2\eta}{3-2\eta} \left(\frac{\widehat{d^2}}{dx^2} + \frac{\widehat{d^2}}{dz^2} \right) (\widehat{xx} + \widehat{zz}) + \left(\frac{\widehat{d^2}}{dz^2} - \frac{\widehat{d^2}}{dx^2} \right) (\widehat{xx} - \widehat{zz}) \quad (iv)$$

where η is Poisson's ratio.

Messrs. Wilson and Gore have determined their \widehat{xx} , \widehat{zz} , and \widehat{xz} from measuring σ_{xx} , σ_{zz} , and σ_{xz} on an india-rubber slab with, I presume, $\eta = \frac{1}{2}$. Their values for these stresses therefore ought to satisfy (i) and (iv); it is difficult to understand how Mr. Martin can believe them to satisfy (i) and (iii) with $\eta = \frac{1}{2}$, which is needful in the case of the masonry dam.

To Sir Oliver Lodge I can only reply:—"Read our memoir and you will find that the influence of the weight of the dam is fully discussed, and experimentally determined. You will also find that the actual tearing was only reached by 'excessive water pressure.'"

With regard to Prof. Brown's views on the effect of the terminals, the following words are used to limit the actual theory applied:—"Let us suppose an indefinitely long dam, or if it be of finite length that its terminals abut against rigid supports." The words *abut against* were purposely used instead of *are built-in* to mark what conditions were being assumed. It is quite another point how far my theoretical dam may be considered an approximation to a real dam. Prof. Brown, emphasising the variability of conditions in any practical case, says that engineers "have used a simple but approximate method of estimating stresses in a dam, based on the flexure of beams." My criticism is that this is not an approximation at all, and that if it were they have neglected to apply their own conditions to the vertical sections, in which case they would have found any existing dam so lacking in stability that they would have promptly dropped a theory which, if carried to its logical conclusion, condemns all existing dams! Now, when an engineer treats a dam as a beam, he forgets two points:—(1) That the length of a beam must be large compared to the linear dimensions of the cross-section. In the case of the dam, its base, the built-in cross-section, is of the same dimension as to depth as the length of the beam, i.e. the height of the dam. The ordinary formulae of flexure are thus absolutely inapplicable, as anyone who knows de Saint-Venant's classical memoir on flexure will at once realise. (2) That the faces of the beam must be free to expand in order that the theory may apply. In applying his theory of flexure, therefore, the engineer, so far from building-in his terminals, does not even suppose them to abut! I contend that if Prof. Brown's balcony were 100 feet broad, but half a mile or a mile long, he would find little difference in the stresses except relatively close to the abutments, whether he supposed the terminals abutted or were built-in. In any case, I am convinced on both theoretical and experimental grounds that for the bulk of the dam far better results will be obtained by applying the uniplanar equations of stress than by an attempt to deal with a solid practically as broad as it is long by a theory of flexure.

That the terminal conditions produce effects goes without saying; I agree with Prof. Brown that we should, if possible, consider them, but their order of importance is that of two terminal supports to a balcony, say 1 foot broad, 1 foot deep at the built-in edge, uniformly loaded, and perhaps 50 feet long. Such effects are purely secondary, and it will be time enough to consider them when we have reached some agreement as to the main stresses; these stresses can be fairly reached by taking, as I have done, an indefinitely long straight dam abutting against rigid terminals.

With most of Prof. Brown's statements in his appreciative criticism I am in complete harmony. No theory will replace local knowledge—that of the geologist as well as that of the engineer—no theory will perhaps be of equal value with past experience, but it can be helpful and even

suggestive. Mr. Pollard and I did not smooth our observations, as has been done in some other cases, because it was desirable to show how much variability is due to local conditions, how much to observational error. Much of what Prof. Brown would attribute to want of homogeneity in our material I know to be due to the changes in external contour, and this is one of the urgent problems of dam construction. Our experimental work shows that very large changes are made by modification of the contour. Is it not possible to reach experimentally better forms for the flank of a dam than are at present in use?

The cost of experimental work on a suitable scale is prohibitive to the individual experimenter, but it appears to me that something on a really big scale ought to be done by the Institution of Civil Engineers. The problem is a very important one, and I do not believe, notwithstanding what I have read to the contrary, that the keen mathematician feels anything but intense awe in the presence of the creative engineer, who has succeeded, notwithstanding the weak-kneed theory provided by men of science, in producing such monumental works as the Assuan and Vyrrwy dams by the force of mechanical appreciation alone.

KARL PEARSON.

The Nature of γ and X-Rays.

In a letter to NATURE of October 31, 1907 (vol. lxxvi., p. 661), a copy of which arrived here recently, Mr. Barkla criticises a paper of mine which was published in the *Philosophical Magazine* for October. In that paper I tried to show how closely the properties of γ and X-rays were in agreement with the hypothesis that they consisted mainly at least of neutral pairs, and I pointed out that even the peculiar polarisation effects which Mr. Barkla had shown to exist might be explained, not unreasonably, as a consequence of the rotatory motion which such pairs would probably possess. I suggested that a pair might be more likely to become entangled with and deflected by an atom revolving in the same plane as itself.

Mr. Barkla describes an experiment in which he has measured the amount of scattering of X-rays in different directions, and compares his results with those which he expects to obtain as the result of calculations based on each of the two hypotheses in turn, that of the neutral pair and that of the ether pulse. He states the results to be against the former theory.

But for the result from his calculations in the case of the neutral pair, he makes the assumption that the probable direction of motion of a neutral pair on emergence from an atom with which it has been entangled is independent of its original direction of motion.

There is no justification for this assumption. It does not even appear to be probable. Consequently, the experiment has no value as a critical test. Yet I fully agree with Mr. Barkla that the dependence of the amount of secondary radiation upon the angle which its line of motion makes with that of the primary ray is a very proper subject of study; it might be expected to furnish much-wanted information.

For this reason I also have been investigating one aspect of this question. With the assistance of Mr. J. P. V. Madsen, of this University, I have been comparing the secondary radiations issuing from the two sides of a plate through which γ rays are passing. On the ether pulse theory there should be complete symmetry, provided that the rays have not been appreciably absorbed on their way through. Secondary radiation, whether material or not, originated in an atom by a passing pulse, is just as likely to go forwards as backwards. This is, indeed, always assumed by writers on the ether pulse theory, e.g. by Mr. Barkla himself in the letter already referred to.

On the other hand, if the γ rays are material, it is quite possible, though not necessary, that the secondary radiations on the two sides of the plate should be different.

As a matter of fact, there is the most remarkable want of symmetry, and this is fatal to the ether pulse theory of the γ rays. Moreover, all our experiments so far show that, on the whole, the kathode radiations from a given stratum of matter traversed by γ rays possess momentum in the original direction of motion of the rays, and this shows that the rays are material.

The experiments are very simple, and are not wholly new. The secondary kathode radiations due to a stream of rays impinging on a plate have been studied by many observers, who all concur in the statement that they increase with the atomic weight of the material of the radiating plate. For example, the figures for Pb, Al, and C are about as 100 to 30 to 15. In fact, they follow almost the same law as in the case of β particles. The reason for this will appear presently. The secondary kathode radiations that appear where γ rays emerge from a plate have been less studied, but Eve has shown that they consist largely of kathode particles, and Dawes (*Phys. Rev.*, xx., p. 182) that they do not appear to follow the same law as what may be called the "incidence" radiations. Further, Wigger has made its very important observation ("Jahrbuch der Radioaktivität," Bd. ii., pp. 428-430) that in certain circumstances the γ rays issuing from a plate of Al which they have traversed make more secondary rays than when they issue from Pb.

All these facts may be conveniently studied together. Let an ionisation chamber be made of cylindrical form with plane ends, and let a pencil of γ rays be directed along the axis. Let the rays first pass through a cm. or so of lead. Let them then pass through a pair of plates which can be inverted; a convenient pair may be made of a lead plate 1 mm. and a carbon plate 1 cm. thick; these are to form one end of the chamber. It will then be found that there is more current through the chamber when the C plate is next to it, and the "emergence" secondary rays are produced in the carbon, than when the Pb plate is next the chamber. But if the plate closing the other end of the chamber be at one time Pb, at another time C, the reverse effect occurs. At this plate "incidence" secondary rays are produced by the same pencil of γ rays, and these are greater when the plate which is struck is Pb than when it is C. The differences are of the order of 10 per cent., 20 per cent., up to 60 per cent., depending on the circumstances of the experiment. The materials and the form of chamber may be largely varied, but the same want of symmetry is always there.

It appears that the "emergence" radiations from the plate through which the γ rays have entered are more important than the "incidence" radiations from the other plate. The latter serves mainly as a reflector or scatterer of the rays from the former, and this is the reason why there is less current when it is formed of a material of smaller atomic weight, following the usual rule for β rays. This effect is a general one, and it serves to explain why all observers have found less kathode radiation due to γ rays from Al or C than from Pb, when actually the rays produce more from the former than the latter when they have been first sifted by a cm. or so of lead. A stream of γ rays contains β particles derived from the γ rays by the influence of the last substance traversed. It is the scattered portion of these which constitutes the main portion of the secondary radiations due to γ rays, and the reason why the incidence radiations run parallel to those of β rays is obvious. Nevertheless, there are small variations due to secondary rays formed in the material of the plate itself, the quantity of which is influenced by the nature, not only of this material, but of the screens through which the rays have previously passed. This is because the γ rays are heterogeneous, as first shown by Kleeman. It is when the rays have passed through some thickness of lead that they are acted on with greater effect by Al or C than by lead. The quantity of kathode radiation set free in the radiator itself depends on the quality of the rays as well as on the radiating material. The particles at first move mainly, perhaps entirely, in the original direction of motion of the γ rays, but are subsequently scattered, and contribute to some extent to the "incidence" secondary radiation. But the principal portion of the incidence radiation is due to β particles which were in the stream of γ rays before it struck the plate.

It would make this letter too long if I were to discuss these results with any fulness, or to show their relations to results already obtained. I hope to publish a fuller account in a short time. Meanwhile, I will point out that the experimental proof of the material nature of the γ rays carries with it, almost surely, a corresponding proof as regards the X-rays. The points of similarity are too numerous for it to be otherwise. Only, as I have said in

the paper already quoted, there should, of course, be ether pulses in the X-ray stream, and the γ stream also for that matter, and it may possibly be these which have been the subject of experiment by Marx, and which show Mr. Barkla's polarisation effects. But I think it is certain that at least the γ rays are material, and those X-rays which give rise to a secondary kathode radiation of a speed due to a few thousand volts.

W. H. BRAGG.

The University of Adelaide, South Australia,
December 12, 1907.

Drifted Ice-crystals.

THE accompanying photographs, showing the incipient freezing of the sea during severe frost on January 4 at



FIG. 1.—Bank of drifted Ice-crystals.

Littlehampton, may be of interest to readers of NATURE. They were taken about high water, at 11 a.m. A high



FIG. 2.—Layer of drifted Ice-crystals.

N.E. wind and the flowing tide had drifted ice-crystals formed on the surface of the sea into the slack water in

the angle between the east side of the small pier and the shore, until they were collected in a viscous layer covering the whole angle. The layer seemed to be more than an inch thick.

The photographs show the border of ice-crystals thrown up on the beach, with a vertical front towards the sea about 18 inches high.

The effect disappeared rapidly when the tide began to fall. The timbers of the pier were thickly coated with ice at high-water mark, and as far above as the splashing reached, but remained perfectly clear below this line.

WALTER LEAF.

The Interpretation of Mendelian Phenomena.

DR. G. ARCHDALL REID has recently suggested (1) that Mendelian phenomena occur only under artificial conditions, and (2) that they are to be explained in terms, not of segregation, but of "latency" and "patency." As regards the latter contention, it appears to me that it would be justified if, in the case of experiments conducted under stringent conditions, dominant characteristics were, even occasionally, to appear in recessive generations or *vice versa*; but if this is not the case it seems an abuse of language to describe a thing as "latent" which never gives any manifestation of its existence. Further, Dr. Reid's theory does not explain—as the Mendelian theory does—why these characteristics not only appear and disappear, but play this game of hide-and-seek in accordance with strict numerical rules.

As to the other point, that Mendelian phenomena are confined to cultivated varieties, it is extremely difficult to prove or disprove, because to ascertain the phenomena you must experiment, and to experiment is to place under artificial conditions. But the well-ascertained facts of conjugation and cell-mitosis, which Mr. R. H. Lock regards as affording considerable support to the doctrine of gametic purity, are certainly not confined to cultivated varieties. That all inheritance may be particulate was long ago suspected by Galton, who speaks of skin colour as possibly "a fine mosaic too minute for its elements to be distinguished in a general view" ("Natural Inheritance," p. 12).

May I suggest one line of inquiry that may possibly prove fruitful in competent hands? Is there any connection between the variability of a plant or animal and the number or size of its chromosomes? Man, for example, has a large number of chromosomes, and is extremely variable. The correspondence would no doubt be far from exact if we suppose with Mr. Lock that the biological units are not the chromosomes themselves, but the chromomeres or some even minuter subdivisions. But it might be assumed, at any rate as a first approximation, that the ultimate units were roughly proportional to the number and size of the chromosomes, and in that case species possessing many and large chromosomes would be likely to have a larger stock of the raw material of variation than their fellows.

H. H. O'FARRELL.

East India United Service Club,

St. James's Square, S.W.,

December 30, 1907.

Musical Sands.

IN reply to Prof. Poynting's letter (NATURE, January 16), may I say that the article which appeared in NATURE (August 6, 1901) was only intended to supplement my paper of 1888, by recording the results of further investigations up to date, and to show that I claimed, both by analytical and synthetic methods, to have proved the theory previously dealt with in detail?

In that paper (1888) I rejected the conception that the notes emitted from musical sands were due to the vibra-

tion of the individual grains as separate particles, because the contact of one grain with another would prevent such vibrations, and suggested that the only other explanation possible was that certain grains, in rubbing one against another, might produce the required vibrations through surface friction.

The music from sands is a cumulative effect, and only possible under the prevalence of numerous favourable conditions, and I found that if I eliminated one apparently insignificant factor from the conditions upon which my theory was based, the production of musical sands artificially became impossible.

Until an artificial musical sand can be produced exclusively under the conditions suggested by Profs. Poynting and Thomson in "Sound," I submit that my explanation may be retained.

Cecil Carus-Wilson.

Filtration of Rain Water.

I wish to ask the opinion of someone in regard to the filtration of rain water, and the removal of any sediment, before it finds its way into large underground cisterns holding fully 15,000 gallons.

It will not be difficult or costly to collect the water and pump it up for use in a large laundry. A pump can be worked by the engine close by.

The point is how to prevent a lot of smuts, &c., finding their way into the cisterns, which would necessitate the frequent removal of this stuff, an operation that would be both difficult and expensive.

Is there any way by which filtration can be carried out above ground?

I shall be glad to know of any way to meet the difficulty.

January 13.

ENQUIRER.

THE HIGHLAND OVERTHRUSTS.¹

THE controversy regarding the structure of the north-western Highlands was a disturbing factor in the progress of geology from 1819, when the problem was first raised by Macculloch, until it was closed in 1884 by Sir Archibald Geikie's announcement in NATURE (vol. xxxi., p. 29) that the generally accepted view could no longer be maintained. The NATURE article—perhaps the most sensational announcement in geological literature—was followed in 1888 by a report from six members of the Scottish Geological Survey (Messrs. Peach, Horne, Gunn, Clough, Hinxman, and Cadell), giving a summary of the evidence which they had collected as to the structure of the north-western Highlands; and it has taken another twenty years to complete the survey of the whole overthrust region and prepare the detailed observations for publication. The full results are now issued in an elaborate monograph, the most important and the cheapest publication ever issued by the British Geological Survey. It includes 700 crowded pages, 52 artistic and instructive plates, and a beautiful colour-printed geological map of the whole area on the scale of four miles to the inch. The price of the book is 10s. 6d. The Survey is to be congratulated on having secured for this memoir a style of production far superior to the usual standard, and on its issue at a price which should ensure for it a wide circulation.

The book no doubt suffers from the inevitable compromise between conflicting requirements. Many readers will never have the opportunity of visiting north-western Scotland, and they will seek in this volume for a clear statement of the general results; their needs are satisfied by the fine photographic plates of the scenery, which show the overthrust

¹ Memoirs of the Geological Survey of Great Britain. The Geological Structure of the North-west Highlands of Scotland. By B. N. Peach, John Horne, the late W. Gunn, C. T. Clough and L. Hinxman, with Petrological Chapters and Notes, by J. J. H. Teall. Edited by Sir A. Geikie. Pp. xviii+622. Plates 52, nsp. (Glasgow: H. M. Stationery Office, 1907). Price 10s. 6d.

structures more clearly than they are often visible through the persistent mists of the west Highland hills, and by the masterly introductory statements by Dr. Horne in chapters i., iii., xxxii., and xl. (of the last of which Dr. Teall is joint author), and the corresponding chapters by Hinxman on the Torridonian, and by Horne and Peach on the Cambrian. The memoir has also to serve as a field handbook to those who can visit the district. Accordingly it has to give precise information, which cannot be too detailed, as to localities and sections. The bulk of the book consists of detailed local descriptions, written by Messrs. Peach, Horne, Clough, Hinxman, and the late W. Gunn, with notes by Cadell, Greenly, and Harker. A third group of geologists will turn to the volume for help in the investigation of other regions of crystalline schists, for nowhere has so large and comprehensive an area of these rocks been subjected to such a searching investigation. The conclusions of this work and the most important evidence are given in a detailed account by Dr. Teall of the gneisses, and altered sedimentary rocks associated with them. The appendix includes a list of fossils and fossiliferous localities, a chemical study of the Durness Dolomites by Dr. Pollard, and a full bibliography by Mr. D. Tait.

The book therefore combines chapters which can be read with advantage by any geological student and others which have to be judged as a collection of materials for reference by specialists. The memoir is appropriately edited by Sir Archibald Geikie, who started the work in 1883, and carefully supervised its progress for eighteen years, until his retirement from the Survey in 1901. It is doubtless due to his literary skill and sense of proportion that the book enjoys a greater uniformity in style and treatment than would be expected in a work extending over so many years, and written by so many men.

The history of the north-west Highlands controversy is summarised in a chapter by Dr. Horne, who lucidly states the results of all previously published geological work on the district. The geological interest of the area dates from the announcement by Macculloch, in 1819, of his discovery of fossiliferous rocks lying above gneisses, and covered by the gneisses and schists that form the great bulk of the Scottish Highlands. Murchison, with his keen scent for a good clue, visited the area, and he re-examined it after the discovery by C. Peach, in 1854, of the better fossils (now known to be Cambrian) in the Durness limestones. Murchison was convinced that the fossiliferous rocks were covered by the eastern gneisses, and, in accordance with the law of superposition, accepted the eastern gneisses as younger than the rocks beneath them. He regarded the fossils as Lower Silurian, and therefore did not shrink from the apparently inevitable corollary that most of the crystalline rocks of the Scottish Highlands are post-Lower Silurian in age. This conclusion had a world-wide influence. Similar crystalline schists form vast regions in all the continents, and they were at first regarded as all pre-Palaeozoic; but if the Scottish schists are altered Palaeozoic sediments, then the similar rocks elsewhere may include rocks of any geological age. To this day vast regions of schists and gneisses are mapped as altered Silurian, in consequence of Murchison's work on the north-west Highlands.

Murchison's views were at once opposed. The common-sense judgment of James Nicol showed him the improbability of Murchison's conclusions, and his keen and careful field-work revealed that the superimposing of schists over sediments was not an original arrangement, but was due to subsequent earth movements. The first controversy was short. Nicol's inter-

pretation of the evidence had not the fascinating simplicity of the other theory, and it was not wholly right. The eastern and western gneisses are not simply repetitions of the same series, and Murchison was apparently right in his view that the upper gneisses and schists are an independent and younger series than the Lewisian gneisses, which underlie the Cambrian band to the west. Moreover, Nicol failed to realise that the apparent bedding planes in the eastern gneisses were not original, but secondary structures due to earth movements.

Murchison, with a theory attractive by its charming simplicity and far-reaching results, and right in his recognition of the essential differences between the eastern and western gneisses, swept his critic from the field. Nicol, disheartened by the fate of views

Nicol's researches" (p. 23), was not enough, although it was supported by the work of Callaway and Huddleston. In 1882-3 Prof. Lapworth mapped in detail the classic sections on the shores of Loch Eriboll; he proved that the apparent sequence was deceptive, and that the eastern gneisses were older than the fossiliferous rocks, and had been placed above them by earth movements; and it was his crowning glory to recognise that many of the fine-grained, shale-like rocks, which look like comparatively unaltered sediments, are the most intensely altered rocks of the area; they consist, like ordinary shales, of fragments of primary rocks, but instead of having been formed by the usual agents of denudation and deposition, they are due to crushing along planes of earth movement.



Unconformability of Cambrian quartzites on Terridon sandstone. Loch Coire Mhic Flearcha'ir, Beinn Eighe, Foss-shire. Reproduced with the authority of the Controller of H. M. Stationery Office.

which he knew to be essentially correct, practically gave up geological research, and went to his grave, his geology despised and his conclusions rejected—by all except his wife. In 1878, the year before Nicol's death, the controversy was re-opened by that geological knight-errant, Dr. Hicks, who ran a tilt against the Murchisonian theory. It survived his on-laught, but two years later it received an almost fatal blow from Prof. Bonney, who, by work near Loch Maree, demonstrated that some of the rocks of the eastern series were the old Lewisian gneiss brought up by faults. The establishment of this fact, which is described in the memoir as "the first important advance towards the solution of the problem of the succession in the north-west Highlands since the publication of

The close of the controversy was now near at hand. In 1883 Sir Archibald Geikie arranged for the detailed mapping of the Loch Eriboll district by the Geological Survey. The work was soon found to be far more complex than had been expected; it was attacked with invincible patience and thoroughness by the surveyors under Peach and Horne; the essential conclusions of Nicol and Lapworth were confirmed, and it was promptly announced in *NATURE* that the Murchisonian theory must be abandoned. In 1888 a preliminary report on the Survey's investigations was published by the Geological Society, but it has taken another nineteen years to extend the survey along the whole of the overthrust line, and to prepare the materials for publication.

The work is of the highest geological importance, and in spite of its necessary descriptive details, every page contains observations of interest. The account of the Torridonian series, for example, describes the oldest considerable land surface known, and some traces of fossils in these pre-Cambrian rocks. The part of most interest is the account of the movements by which the eastern gneisses have been overthrust on to the younger rocks. The movements have taken place along a line more than 100 miles in length, and have carried the rocks in places ten miles westward. The thrusting forward of these hard rock slices has produced a most intricate system of faults, and extreme changes in the rocks, some of the fresh structures, as in the pseudo-rhyolites, simulating those of igneous rocks. The extent of the metamorphism is one of the secondary questions of most interest. Its range appears to be very variable; in places the alteration is confined within very narrow limits; elsewhere it may extend to a mile from the plane of movement; but it never appears to be regional, and evidence is given that some of the schists had their present structures before the great disturbances. The problems connected with the eastern schists are handled with reserve, as there seem to be marked differences of opinion as to their age and origin; but on the main question, the relation of the schists to the fossiliferous rocks, the memoir, with its convincing combination of fulness of detail and clearness of exposition, leaves no room for doubt.

J. W. GREGORY.

THE TOTAL SOLAR ECLIPSE OF JANUARY 3, 1908.

THE first cablegram, containing news relating to the eclipse of January 3, observed by the parties stationed on Flint Island in the South Pacific, reached this country on Saturday last. The cable was from Mr. F. K. McClean, and was dispatched immediately on his arrival at Auckland, New Zealand. It read as follows:—"Partial success, fine morning, heavy rain several minutes until totality; first minute cloudy, remainder clear. Four corona results; none spectrum; bad plates; other observers not developed. Campbell reports success."

The above news is really very satisfactory, because it was anticipated by those at home that the weather conditions which generally prevailed at that time of the year would most probably prevent any observations at all being made. There is, however, no doubt that the parties were very fortunate, since, according to the above account, the clouds only just cleared from the neighbourhood of the sun in time.

Those who have been on like expeditions will be able to picture to themselves the anxiety which must have prevailed among the observers as totality was approaching. The heavy rain must have necessitated the covering up of all the instruments, more especially the silvered mirrors and object glasses. The clearing up, after totality had begun, must have created a condition of affairs which was probably not legislated for in the "rehearsals" which had no doubt been daily gone through.

The fact that the length of totality was of four minutes' duration gave probably sufficient time for all the instruments to be brought into use. It is hoped, therefore, that a very complete record has been obtained of the latter portion of totality, and, if this be so, then the term "partial success" may be changed to complete success.

With regard to actual results obtained little is known at present. The reason of this is that the development of the negatives secured was not com-

pleted on the island. Mr. McClean provided himself with a dark room on board the steamer he had chartered, so he may have developed his corona negatives on his way back to Auckland. According to his cable four of the plates he exposed were successful, but the words "bad plates" seem to suggest that the results he obtained were not so good as they might have been.

Reuter reports that the observations of the different parties at Flint Island and Samoa were, generally speaking, fairly successful, and mentions specially that the bolometric measurements of the heat of the corona made at Samoa were successfully made.

WILLIAM J. S. LOCKYER.

THE BRITISH SCIENCE GUILD.

THE second annual meeting of the British Science Guild was held on January 15 at the Mansion House, the Lord Mayor being in the chair. The large assembly of fellows and members, and the presence of distinguished representatives of many departments of intellectual activity and national interest, show that the Guild is strengthening and extending its influence over a wide field.

The report, which was adopted, referred to the missionary work of the Guild in educating the public in the following terms:—

The executive committee believes that in this direction the labours of the Guild are becoming more effective each year, and there is a gradually increasing volume of opinion chronicled or expressed in the daily and weekly Press in harmony with the main objects of the Guild.

For this result a large debt of gratitude is due to the president, Mr. Haldane, who has taken many opportunities of expressing and emphasising the views of the Guild before large audiences in connection with various educational institutions.

It is in the direction of primary education that the most rapid advance in public opinion has taken place, and on this the nation is to be congratulated, for it is on the proper education of the children that all future progress must ultimately depend. At the inaugural meeting of the Guild in 1905, the chairman of committees, in referring to the subject of education, pointed out that a complete education must be based upon things and thinking as well as words and memory, and that we want "one kind of education for everybody—the Best." Further, that no one should be stopped on his upward course save by his own incapacity; and that all impediments should be removed. These views are now being acted on in many places.

The Guild is not alone in pointing out that our great commercial competitors are those lands where there is the greatest number of complete and State-aided universities, and in which as a consequence "all the national activities are carried on in the full light of modern science by men who have received a complete training both in science and the humanities, in close touch with the Governments."

Some of the City livery companies have shown great interest in the work of the Guild. The Clothworkers' Company has made a donation of 100*l.* to the funds, and the Drapers' Company one of 105*l.* This evidence of the interest taken in the movement is very gratifying, and it is hoped that other City companies will similarly assist in furthering the objects of the Guild.

Numerous subjects have occupied the attention of the executive committee during the year, and several deputations to various Ministers of State have been arranged. Among questions thus dealt with may be mentioned the amendment of patent laws, the anthropometric survey of school children and adults, and the prevention of pollution of rivers. Deputations had also been planned to the Colonial Premiers and in connection with vivisection licences, but subsequent circumstances made these unnecessary.

In addition to this work of the executive committee, committees have been appointed by the Guild to deal with education, inexpensive apparatus in science teaching, agriculture, chemical industries, the Franco-British Exhibition, postal reform, and biological subjects.

The question of university endowments has received the earnest attention of the Guild; and the following considerations relating to it are stated in the report:—

The necessity for increased endowment has been, to a large extent, conceded, especially by the last Chancellor of the Exchequer, Mr. Austen Chamberlain. In 1904 the then endowment was increased, and a still greater increase was promised. But it was pointed out that, until the universities themselves had considered to what extent they were willing to come under inspection, it was difficult to deal with the question of still higher endowments.

The existence of large college endowments at Oxford and Cambridge places these universities in a different position from the rest, although the small endowments of the universities themselves are felt as strongly as in the other universities.

The Scotch universities, like Oxford and Cambridge, receive no Government assistance. The University Act of 1889 gave to the Scotch universities, not as a boon or gratuity, but as an absolute right, 42,000*l.* a year. This represented obligations which the Government had taken upon itself when it assumed possession of property which belonged to the universities, and which, had it remained to them, would have brought in a larger revenue. In 1892, 30,000*l.* a year was added; it was not a special grant from Government, but came entirely from the Scottish Local Taxation Fund, in which no other part of the kingdom had any concern. England might, had it pleased, have assigned a share of the English Local Taxation Fund to the universities, but she did not do so.

Whether or no it is desirable that a large proportion of the college funds at Oxford and Cambridge be applied to various branches of real university teaching and of post-graduate research is a matter on which members of the Guild might have much to say.

It is also hoped that in time the new universities will be provided with funds for the establishment of hostels, such as the Oxford and Cambridge colleges are to a large extent. This provision, however, may fairly be made in the case of the newer, as of the older foundations, by private munificence, and not by Government aid.

The ultimate aim should be State, municipal, and private endowment for all universities.

Universities supported entirely by municipalities are impracticable, as the influence of a university must extend over a large area, which will increase as its specialisation is proceeded with; this renders the application of local rates, and therefore local control alone, unfair and undesirable.

It is possible that the old English universities themselves would be among the first to welcome an inquiry which might consider the best way of placing matters on a more satisfactory footing.

In July the question of a Royal Commission on the older universities was brought forward in the House of Lords by the Bishop of Birmingham. Lord Crewe, in communicating to the House the decision of the Government, stated, "it is important for us, before arriving at a final conclusion, to know what the most thoughtful and the most competent opinion at both universities really demands, and we also must either inform ourselves or be informed exactly what the universities cannot do of their own motion, and for what purposes legislation would be required."

In consequence of this decision no further action has so far been taken by the executive committee.

After the meeting had been opened, Mr. Haldane, Secretary of State for War, and president of the Guild, gave an address to the members. For the subjoined report of his remarks, and of those made by Dr. T. H. Warren, vice-chancellor of the University

of Oxford, we are indebted to the *Times* of January 16:—

Mr. Haldane said that the Guild was a body of people who had come together for the purpose of organising interest in science, an interest which had not been, as they thought, sufficiently great. It also aimed at assisting those who had scientific objects to accomplish to find the means of accomplishing them. They endeavoured to stimulate successive Governments. Governments were very apt not to be quite as scientific as everybody might desire, and the most perfect embodiment of the work of the Guild was when they got the two functions combined. For instance, the War Minister in this country was apt to take an easy-going view of organisation, but if the president of the Guild was always at his elbow to remind him that what he was doing was unworthy of one who was acquainted with the principles of the Guild, then something was gained, and if the two happened to be rolled up into one person physically who could divide himself spiritually into two, then they had an ideal combination. It was encouraging to see signs of progress everywhere in this country. Only that morning he had seen the announcement that Mr. Wills had offered the University College of Bristol 100,000*l.* if it was incorporated into a University of Bristol. This enterprise would come within the range of the criticisms of those who complained of small universities, but the matter had been threshed out before the Privy Council when the question of the granting of a charter to the University of Liverpool came before it. The special committee of the Privy Council selected to give a judicial opinion on that question pronounced in favour of an increase in the number of universities in England. That policy had been carried out with the utmost success. An extraordinary development was going on just now in the direction of the application of science to industry. At Armstrong College, Newcastle, which was a part of the University of Durham, he found the other day a change which he could hardly have credited had he not witnessed it.

In certain buildings there were organised the scientific foundations of the shipbuilding industry in a fashion which was beyond praise. The professors of mathematics, of engineering, of physics, of applied mechanics, of designing were all working with one purpose, which was to provide a school of the university type, for, among other people, those who were to be engaged in the practical business of shipbuilding. On the other hand, the shipbuilders on the Tyne were sending up their young men in order that they might acquire knowledge of the principles of the construction of compound engines, and how to solve the thousand and one problems constantly coming up in the construction of a great liner. The effect of that was immense, not only in stimulating the interest in university work, but upon the great industries in the neighbourhood. He saw the same thing at Sheffield. Part of the university looked very much like a steelworks. There were places with great crucibles and all the apparatus for the purpose of casting steel. There were brawny workmen there, obviously come from the works, and students of the university were working with them and mastering that most important work of metallurgy. He did not suggest that they should bring down the university to the simple function of applying science to industry—far from it—but they would gladly see in our provincial centres, which the Universities of Oxford and Cambridge could not reach, facilities given which existed in other countries, but did not exist in our own country. He wished God-speed to the new enterprise, and he knew that his colleague in the Government, Mr. Birrell, who sat for the city of Bristol, was deeply interested, like himself, in the success of the movement. This year, moreover, the Government had in its programme the giving of teaching of a university type in an enlarged and extended degree to Ireland. Ireland had one great university, the University of Dublin, consisting of Trinity College, but they felt that, valuable as was the work and greatly to be revered which the University of Dublin had done, it could not provide for the needs of the Irish people, who suffered much from there being no outlook, no career for the talent of their young men, and particularly of the Catholic and middle classes. The Govern-

ment had to provide education, not of a sectarian kind, but in an atmosphere which would not offend sectarian prejudices. The negative was a very different thing from the affirmative in that matter, and if that was attained he did not see why education could not be given to Belfast and Dublin, to the Presbyterians and Catholics of Ireland alike, an education of a university type which would not run athwart those feelings and considerations which obtained to so high a degree among the Irish people. That was a step in the direction of solving a very difficult problem which had embarrassed Governments before now and which might embarrass this one, but they hoped to try, and it was a sign of the times that they should try. In Scotland a step forward in the spirit of that guild had been taken very recently. They had brought the teachers into close relation with the Scottish universities. The training of those teachers used to be undertaken by the churches. It was no want of reverence or respect for the churches which led him, speaking from that platform, to say that in Scotland they preferred that the universities should train their teachers rather than that they should be trained in any denominational atmosphere, however excellent. He was not touching in the least on the question of denominational colleges. The university, after all, ought to be at the head of education, and to permeate downwards, and could not do that unless it trained the teachers for the work. It was not only in the direction of university teaching that the signs of the permeation of the new spirit were to be seen, and in the departments of the Government numerous little things had happened lately to show how progress was being made. In these days science was becoming more and more of moment in the race between nations. No industrial community could retain its place unless it had got the highest science at its disposal. If he were to adopt a motto for that guild, it would be the motto of a German trade association, which ran:—"Science is the golden guiding star of practice; without science there can be only a blind groping about in the region of undefined possibilities." The change that had come over things in the last fifty or sixty years was immense. Without science no one could organise his business; without science no nation could keep its place in the van. Therefore he said that one of the great responsibilities of a nation was not only to keep her knowledge in the minds of a few individuals abreast of the age, not only to produce her Kelvins and her Darwins, but to see that her science was disseminated, and that it had entered the minds and actuated the endeavours of her captains of industry generally. That was the creed of that guild, and that was the lesson which they had come together to endeavour to teach.

In moving the adoption of the report, the Vice-Chancellor of Oxford said that in the report they would find some remarks and some criticism, implied rather than developed, upon the older universities. Speaking for Oxford, he did not deprecate that criticism. He desired measures and large measures of reform in Oxford and her colleges. He did not agree with his friend the Bishop of Birmingham in invoking as a first step the interference of the State. He would like to see Oxford reform herself. But he fully recognised that when the Government had given her, as it had, this opportunity of doing so, if she failed to use that opportunity this Government, or any other Government, would have strong justification for stepping in and reforming her from outside. He wished to see reform both in her constitution and her curriculum, both in the colleges and the university. On what lines should that reform proceed? He would say on the lines indicated by the British Science Guild. They would find in the report a suggestion that college funds might be more largely used to aid the university. He believed they might, and he believed they ought to be more largely used in this way. But they would find also a recommendation that the new universities should be provided with funds to establish hostels such as the colleges at Oxford and Cambridge very largely were. He took it that the British Science Guild did not want to abolish the colleges. He certainly thought that would be a pity. Hostels they were, but they were something more than hostels. Some would say they were only glorified hostels. He would say they were glorious hostels. Trinity College and King's College

at Cambridge and Christ Church and New College and Magdalen at Oxford—he thought all who knew them would agree that they merited that description, and that their glory was part of the educating influence and the attracting spell of the older universities, that they were an academic, aye! and a national asset which it would be folly to throw away or destroy. In the appendix to the report there were some remarks about the tardy and sluggish response on behalf of the private benefactor to the appeal of the University of Cambridge, to the unattractiveness of the universities generally to the benefactor. To bring that appendix up to date mention should be made of a new fact. The president had brought the report up to date by referring to the splendid gift that was announced in the *Times* of that morning, the gift that one of the heads of a great and generous family in the ancient city of Bristol had made to its college. Might he, as an old Bristolian, ask them to send their thanks to that generous family which had already done so much for that city, and had now come forward with this benefaction? He remembered the famous motto in which Bob Lowe suggested that money might be made out of matches—*ex luce lucellum*. He thought the Wills family had taken a better motto. Theirs seemed to be *ex fumo dare lucem*. They had all read, a few weeks ago, of the magnificent bequest left by Sir W. Pearce to the Royal and religious foundation of Trinity College, Cambridge—money made, by the way, in applied science; it was enough to make, and he believed made, mouths water, not only in the University of Cambridge, but in the other colleges of Cambridge, and in some colleges in Oxford too. For his part he welcomed that bequest. He congratulated his old friends of Trinity College. It was a great example. If Trinity used it well, and he believed the college of Newton and Clerk Maxwell, and Macaulay and Tennyson, would use it well for the public benefit of the university, not for any self-aggrandisement, it would be a greater example still, and might well prove contagious. He thought that college funds should be used much more largely for the university, and that the college should be brought into closer and more responsible relation with the university. He thought, too, that the university needed reform in its curriculum. If there was anything about which he had been persistently keen all through his academic course it had been the desire to introduce science into the regular and compulsory curriculum of Oxford, to ensure that everyone who took the ordinary degree should at least know what science and the scientific attitude of mind were like. But he did not want literature excluded. The ideal was, he thought, that all literary men should be scientific and scientific men literary. The highest ideal, to his mind, would be that Oxford scientific men should know Greek, for Greek literature was the most educating literature, and the Greek language the finest language that an Englishman could study. But he was afraid that was not practicable, and if they were not to know Greek, they should know our own splendid literature, the next in fertility and force to that of Greece. They should know, too, the lucidity of French and the philosophy of German. If they could not study Sophocles and Plato, let them at least study Bacon and Pascal, Goethe and Tennyson.

Sir A. Geikie, K.C.B., Sec.R.S., in seconding the motion, remarked that one great function of the Guild is to lose no opportunity of saying a word in season and out of season to educate the Government and the people to realise that, unless we have a scientific spirit and method, we cannot compete with nations which are working in that spirit and by that method.

After the adoption of the report, the following vice-presidents were appointed upon the proposal of Sir William Bousfield, seconded by Sir John Rhys:—Lord Curzon, the Rev. the Hon. E. Lyttelton, Lord Iveagh, and the Prime Ministers of Australia, Cape Colony, New Zealand, and Natal.

Sir E. Busk moved, and Mr. F. Verney, M.P., seconded, a resolution, which was carried, approving of the members of the executive committee. Prof. R. Meldola, F.R.S., then moved a vote of thanks to the

Lord Mayor, and in the course of his remarks referred to the attitude of science toward the public and of the public toward science; he pointed out that although there are branches of science which cannot be popularised, the practical results can be described.

The vote of thanks was heartily accorded, and the Lord Mayor having briefly acknowledged it, the meeting dispersed. The following telegram was dispatched to the Lord Mayor of Bristol:—

"Lord Mayor of London, on behalf of British Science Guild at annual meeting, sends warm congratulations to Lord Mayor and city of Bristol on generous munificence of Mr. Wills to Bristol University College, and hopes soon to welcome University of Bristol."

The following reply was subsequently received from the Lord Mayor of Bristol:—

"On behalf of my fellow-citizens and myself I beg to thank your lordship and the British Science Guild for your warm congratulations on the munificent promise towards the endowment of a Bristol University by our fellow-citizen, Mr. Harry Overton Wills."

J. MACFARLANE GRAY.

WE regret to announce the death of Mr. John Macfarlane Gray on January 14, at his residence in Edinburgh, in his seventy-sixth year. Mr. Gray had a varied experience as an engineer, and was for many years chief examiner for marine engineers at the Board of Trade. The work which first brought him into prominence was his invention in 1866 of the steam steering gear which was first applied to the *Great Eastern*. The results led eventually to the general adoption of the system. Mr. Gray contributed numerous important papers to the various institutions to which he belonged, and frequently took part in discussions at the meetings, his contributions being characterised by pawky humour and sound knowledge of the subject. His contributions to scientific knowledge were for a time curtailed by the action of the Board of Trade, who, on the ground that the individual opinion of any of their engineering officers must not be made public, refused him permission to discuss the report of a research committee of the Institution of Mechanical Engineers. Fortunately he had previously been able to publish the results of his important investigation of the Theta-Phi diagram.

The most valuable of Mr. Gray's papers were probably those on the theoretical duty of heat in the steam engine (Institution of Naval Architects, 1885); the ether pressure theory of thermodynamics applied to steam (*ibid.*, 1889); the rationalisation of Regnault's experiments on steam (Institution of Mechanical Engineers, 1889, and Royal Society, 1900); and the variable and absolute specific heats of water (Institution of Civil Engineers, 1901).

Mr. Gray was a member of the Institution of Mechanical Engineers. He was a vice-president of the Institution of Naval Architects, and vice-president of the Institution of Marine Engineers from its inception. Of humble origin, he was essentially a self-trained engineer, and his early training undoubtedly influenced his attitude towards scientific research, his independence of judgment being specially noticeable. His seventy-six years show a record of useful activity, and he may be said to have created a field of investigation for younger engineers, who have fully recognised the influence of his guidance. An excellent portrait of Mr. Gray accompanies the lengthy biography published in *Engineering* of January 17, from which source these brief particulars have been drawn.

NOTES.

WE regret to see the announcement of the death, on January 4, of Prof. C. A. Young, for many years professor of astronomy at Princeton University, at the age of seventy-three.

DR. FEODOR CERNSHIEV, St. Petersburg, has been elected a foreign correspondent of the Geological Society of London.

PROF. REGINALD W. BROCK, professor of geology in the Queen's University, Kingston, has been appointed director of the Geological Survey of Canada.

At the annual meeting of the Royal Meteorological Society on January 15, the Symons memorial gold medal was presented to M. Leon Teisserenc de Bort, of Paris, "in consideration of the distinguished work which he has done in connection with meteorological science, especially the study of the upper air."

THE freedom of the city of Glasgow was conferred upon Lord Lister on Tuesday at a large and representative meeting of citizens, over which the Lord Provost, Sir William Bilsland, presided. In making the presentation, the Lord Provost recalled Lord Lister's connection with the city while professor of surgery at the University and visiting surgeon at the Royal Infirmary, where he achieved world-wide distinction as an investigator and a surgeon by discovering and perfecting the antiseptic system of treating wounds, which marked a new epoch in modern surgery. Lord Lister was unable to be present at the meeting owing to his condition of health, but a letter was read from him in which he said:—"Having in due time been elected by the managers of the Royal Infirmary as surgeon to that institution, I experienced uniform consideration at their hands when applying to the treatment of wounds the great truth which had been recently revealed by the illustrious Pasteur regarding the nature of fermentative changes in organic substance. That truth, though it seemed to me to shine clear as daylight from Pasteur's writings, was for many years not generally recognised, and thus it was my privilege to witness in my own practice, as the application of the principle became greatly improved, the revelation of pathological truths of fundamental importance and a revolution in practical surgery, and I looked upon the years spent in your city as the happiest period in my life."

On Tuesday next, January 28, Prof. F. J. Haverfield will deliver the first of two lectures at the Royal Institution on Roman Britain. The Friday evening discourse on January 31 will be delivered by Prof. Rutherford, on recent researches on radio-activity, and on February 14 by Dr. C. W. Saleeby, on biology and history. The discourse on March 13 will be delivered by Signor G. Marconi, his subject being Transatlantic wireless telegraphy.

At the annual meeting of the Entomological Society on January 15, the following fellows were elected as officers and to serve on the council for the session 1908-9:—*President*, Mr. C. O. Waterhouse; *treasurer*, Mr. A. H. Jones; *secretaries*, Mr. H. Rowland-Brown and Commander J. J. Walker; *librarian*, Mr. G. C. Champion; *other members of the council*, Dr. T. A. Chapman, Mr. A. J. Chitty, Mr. A. Harrison, Mr. W. J. Kaye, Dr. G. B. Longstaff, Mr. H. Main, Mr. G. A. K. Marshall, Prof. R. Meldola, F.R.S., Prof. L. C. Miall, F.R.S., Prof. E. B. Poulton, F.R.S., Mr. R. Shelford, and Mr. G. H. Verrall. The president read his address, which

dealt chiefly with the present unsatisfactory state of nomenclature in entomological science. He also advocated the establishment of a central "type" museum, on the lines of an experimental collection now formed at South Kensington, for the purpose of loaning specimens to institutions, whereby it was suggested that the existing confusion might be avoided, and the general work of identification made easier.

At a meeting of friends of the late John Samuel Budgett held in Cambridge on February 8, 1904, it was decided to perpetuate his memory by the publication of a memorial volume which should contain reprints of his various zoological papers, together with descriptions of the more important material brought back by him on his various expeditions. The syndics of the Cambridge University Press undertook the responsibilities of publication, the necessary expenses of illustration being met by a fund subscribed by Budgett's friends. The volume has been edited by Prof. Graham Kerr, and Mr. A. E. Shipley, honorary treasurer of the fund, has contributed a biographical sketch. The preparation of the volume has taken a considerable time, particularly the working through of the extensive embryological material of *Gymnarchus* and *Polypterus* so as to make it possible to give a fairly complete sketch of the development of these forms.

We regret to announce the death of Dr. H. G. Knaggs in his seventy-sixth year. Though little known to the present generation of entomologists, his name deserves to be honoured as that of one of the founders of the *Entomologists' Monthly Magazine* in 1864. At that time he possessed one of the finest collections of British Lepidoptera in existence, but ten years later he found that his professional engagements required all his attention, so he sold his collection and withdrew from the staff of the magazine, to which, however, he continued to contribute occasionally up to July, 1906. He also published one or two small books and pamphlets, especially "The Lepidopterist's Guide," one of the most useful publications on the collection and preservation of these insects which we possess. It originally appeared in separate papers in the early volumes of the *Entomologists' Monthly Magazine*, and was afterwards enlarged and published in book form, and has gone through several editions. Dr. Knaggs was born on March 21, 1832, in High Street, Camden Town, and was educated at University College School, and trained for the medical profession at University College Hospital. He practised as a medical man in Kentish Town and Camden Town until about ten years ago, when he retired in consequence of ill-health, and settled at Folkestone, where he died after a long and painful illness on January 16. His remains were interred in Highgate Cemetery on January 20, in the presence of a small company of relatives and friends.

Nos. 5 and 7 of vol. II. of the Bulletin of the Museum of Comparative Zoology at Harvard College are devoted to echinoderms. In the former, Messrs. A. Alexander and H. L. Clark describe the echinuses collected during the cruise of the *Albatross* in the North Pacific. In the latter, Mr. Clark publishes a revision of the *Cydaris* group, with a full account of the intricate questions connected with nomenclature.

THE "waltzing instinct" in ostriches forms the subject of an article by Dr. J. E. Duerden in the Journal of the African Ornithologists' Union for December, 1907. Ostriches, it appears, are in the habit of running off suddenly with a peculiar whirling movement, sometimes one way, sometimes another, simultaneously spreading

their wings, which are alternately raised and depressed. These movements, the author suggests, may be connected with escape from the clutches of the large Carnivora. "Indulged in instinctively as play while young, and even when adult, the performance gives the bird expertness in the rapid jerking movements which are those first followed on alarm."

THE use of chrysanthemum powder as a means of destroying mosquitoes in houses is strongly recommended by Dr. A. L. Herrera, of Mexico City, in a paper published in the Proceedings of the nineteenth annual meeting of the Association of American Economic Entomologists (U.S. Department of Agriculture, Entomological Bulletin No. 67). Care has to be exercised in order to avoid the production of throat-inflammation in the operator, and also against ignition, but if proper precautions are taken in these respects, the powder seems to produce most satisfactory results. The consumption of the powder has largely increased during the last year, while the sale of tablets, which only paralyse the insects, and at the same time give off noxious fumes, has shown a corresponding decrease.

An interesting addition to the exhibition galleries of the British Museum (Natural History) has been made in the shape of a copy of a water-colour drawing made about 1585 by John White, containing the earliest known representation of the American king-crab, *Limulus polyphemus*. John White, who was one of the first settlers in Virginia, of which he was for some time Governor, served as Lieutenant to Sir Walter Raleigh. In three volumes of drawings by him preserved in the department of prints and drawings in the British Museum, many of the delineations of natural objects are of great beauty, and show a fidelity to nature rare at the period. The drawing in which the king-crab is depicted was engraved, with some modifications, for de Bry's "America" ("Grands Voyages," part i., pl. 13) in 1590. In the engraving the king-crab is, however, shown in somewhat greater detail, thus suggesting that the engraver had an actual specimen or another drawing from which to copy.

It is encouraging to find Dr. Whitehead, Bishop of Madras, giving an example to other missionaries of the true method of dealing with the beliefs of those non-Aryan tribes which offer the most promising field for Christian work in India. He is, we believe, a comparative stranger to the people of the south, and hence his essay lacks that intimate familiarity with these strange cults which is essential to one whose mission is to comprehend and refute them. But in his pamphlet on "The Village Deities of Southern India," recently published in Mr. Thurston's valuable series of Bulletins of the Madras Museum, he has collected much curious information hitherto inaccessible to English students. Although most of his facts appear to have been derived from Christian converts, his account of these strange beliefs seems as complete as is possible in the present state of our knowledge. He points out that these deities are usually female, are almost universally worshipped by animal sacrifice, and that their priests are not Brahmans, but drawn from the lower castes. He describes in detail the grosser modes of sacrifice, which he regards as not in the nature of gift or propitiation, but as methods of gaining communion with the deity. This study of the seamy side of Hinduism shows that this comprehensive faith is not, as is too commonly believed, a purely philosophical creed. His essay will be useful to ethnologists as a study of the lower beliefs of a pagan polytheism, which, crude and monstrous as some of its

practices are, is still on a higher level than the foul Śākta worship current in Bengal, to which it presents many obvious analogies.

In the *Times* of January 17, Dr. H. R. Mill gives an interesting statement of the rainfall of the British Isles during the past year, compiled from a preliminary examination of the large mass of material so far received from the observers of the British Rainfall Organisation. It shows that, for the United Kingdom generally, the year 1907 was not a wet one, despite the popular belief, but that, in fact, the rainfall was very close to the average of thirty years (1870-1899). Expressing the amounts in percentages, the following provisional values are obtained:—

General Rainfall in 1907. Average=100.

England (South)	Wales	England (North)	Scotland	Ireland	British Isles
99	101	97	106	102	101

The most prominent features were the very wet three months of spring and early summer, and the extremely dry September; this month scarcely yielded a quarter of its average rainfall in England and Wales, and less than a third for the British Isles as a whole. In London (Camden Square) the annual fall was 23.01 inches, 8 per cent. below, and the number of rain-days 9 per cent. above, the average of fifty years (1858-1907). Dr. Mill states that the large number of rain-days, combined with the unusually low temperature of the summer, quite account for the general impression that last year was very wet in London.

In *Mitteilungen aus den deutschen Schutzgebieten* (vol. xx., part iii.) there is an important discussion of the climate of Swakopmund by A. Gülland, based on observations for the years 1899-1905. Swakopmund lies in 22° 42' S. lat., on the west coast of the German South-West African Protectorate.

A PAPER on the fruits and seedlings of *Rhus succedanea*, contributed by Mr. S. Tabata to the *Journal of the College of Science, Tokio* (vol. xxxiii., article 3), furnishes a brief account of a microchemical examination of the substances found in the fruits. The fruits are the source of the fat or tallow that enters into commerce as Japan wax. The fat is present in all parts, but only assumes a waxy consistence in the mesocarp. Before germination of the seeds, the cotyledons contain fat, magnesia, and proteins in considerable quantity, but no starch. Starch is formed during germination at the expense of these substances.

AN article on the absorption spectrum of protochlorophyll is communicated to the *Bulletin du Jardin impérial botanique*, St. Petersburg (vol. vii., part ii.), by Mr. N. A. Monteverde. An alcoholic solution of the colouring matters prepared from the leaves of etiolated oats and wheat plants provided the protochlorophyll and accessory yellow pigments. Five bands were observed in the absorption spectrum, of which one in the blue is attributed to the yellow pigments, and the other four, in the orange, yellow, green, and blue, are referred to the protochlorophyll.

THE first of a series of papers by Dr. L. Cockayne dealing with the coastal vegetation of the South Island of New Zealand is published in the *Transactions of the New Zealand Institute*, vol. xxxix. In this part the author presents a general sketch of the coastal plant covering. Although the saline nature of the soil and the strong winds are recognised as potent factors influencing distribution, the opinion is expressed that the coastal plants as a whole occupy their peculiar station, not from choice, but from necessity, having been driven out of more favour-

able situations by better equipped competitors. The vegetation of the South Island below the parallel of 42° S. bears the impress of a subantarctic origin in some of the coastal formations, whereas in the North Island a subtropical element is more characteristic. Of ninety-four species enumerated, more than half are endemic and thirteen are subantarctic.

UNDER the title of "Heredity and Forestry," Prof. W. Somerville discusses in the *Transactions of the Royal Scottish Arboricultural Society* (vol. xxi., part i.) an interesting matter with regard to the results obtained by sowing seed of forest trees from different localities. Comparative experiments in Switzerland have shown that plants raised from the seed of the common spruce grown at a high elevation, e.g. 6000 feet, make much slower growth than plants raised from seed grown at a lower elevation, e.g. 2000 feet. Similar results have been recorded for spruce in Austria. Other characters, such as the weight of the seed, length of growing period, and possibly tendency to disease, appear to vary with the situation of the trees from which seed is taken. It becomes, therefore, important to obtain seeds for afforestation purposes from a locality similar to that in which the plantation will be made. The conclusions appertaining to the spruce do not necessarily apply to other trees, such as the Scots pine, for which data are not available.

MR. DRYSDALE TURNER contributes to the December (1907) number of the *Agricultural Students' Gazette*—the organ of the Royal Agricultural College, Cirencester—an interesting summary of the life-history of the warble-flies *Hypoderma lineata* and *H. bovis*. Considerable losses are caused by the ravages of this insect in Great Britain, and farmers and stock-keepers are fully alive to the necessity of keeping it in check. *H. lineata* resembles a bee in appearance, and can be seen from the middle of May to the beginning of September. It attaches its eggs to the hair on the various parts of the bodies of cattle, particularly the legs, just above the hoofs. The animal licks the place where the eggs are deposited, and the larvæ are carried by the tongue into the mouth and to the gullet, through the walls of which they pass, and eventually lie just under the skin on the animal's back; the developed maggots finally work their way out of the skin about June, and fall to the ground, where they pupate. *H. bovis* probably has a similar history. Various remedial measures are quoted, and in particular it is stated that the parish of Bunbury, in Cheshire, has been freed from the pest by systematically destroying the maggots. The same journal also contains a *résumé*, by Prof. Duncan, of the regulations that have been made from time to time concerning contagious diseases in animals.

THE *Journal of the Department of Agriculture of South Australia* for November, 1907, contains an account of the wheat yield during the last decade, and the estimated yield for the present season. The figures are very striking; they are as follows:—1897-8, 2.64 bushels per acre; 1898-9, 4.91 bushels; 1899-1900, 4.64 bushels; 1900-1, 5.88 bushels; 1901-2, 4.60 bushels; 1902-3, 3.64 bushels; 1903-4, 7.72 bushels; 1904-5, 6.53 bushels; 1905-6, 11.46 bushels; 1906-7, 10.19 bushels. The fact that the last two seasons gave much higher yields than usual is attributed to the use of artificial manures and to timely rains. As the rainfall during the past twelve months is below the average, a yield of only 8.75 bushels is predicted for the present season. When we remember that the average wheat yield in Great Britain is 30.9 bushels, and the average of the yields of all other countries is 17.5 bushels,

it would appear that there is considerable scope in South Australia for agricultural investigation, and that a strong scientific staff would prove a really sound investment.

In a paper on "ghost images" published in the Journal of the Royal Microscopical Society, clxxxi. (December, 1907), Mr. A. A. C. E. Merlin discusses the resolution of the images of a substage stop formed by the secondary markings of the diatom *Coccinodiscus asteromphalus*. The diameter of the secondaries was $1/83300$ th of an inch, and the images appeared well defined under a magnifying power of about 3200. In connection with this effect, the author discusses the advantage of high magnification, independently of the question of resolving power, and especially advocates the use of powerful eye-pieces in studying minute structures. While a structure may be equally well defined under a lower magnification, and may be visible when it is known to exist, the author considers that for the recognition and detection of unknown detail a powerful eye-piece is a necessary adjunct to a picked objective.

The Transactions of the Theosophical Congress for 1907 contain much matter that falls outside the range of "science" as included in the columns of NATURE. There are two papers on the dimensions of space which form in some ways an exception to the above statement, and the writer of one of these, who does not publish his full name, gives some diagrams by which it is possible to construct models of projections of the simpler four-dimensional solids. The author, however, considers that the sections of the 600-cell and the 120-cell "become so complicated as not at present to be worth calculating," and on p. 258 he shows by his own statements that he is unaware of the work that has been done in "exhausting" the regular figures in space of higher dimensions than four. Indeed, he says—"It seems to me quite possible that we might find that in a five- or six-dimensional world *no regular hypersolids at all were possible.*" But a little thought can be made to show anyone with a small mathematical knowledge that the triangle-tetrahedron series, the square-cube series, and the octahedron series are capable of extension to space of any dimensions whatever.

The December (1907) number of the periodical of popular science, *Himmel und Erde*, published by the scientific society "Urania," of Berlin, contains an article on the microscopic structure of photographic films by Dr. W. Scheffer. It is illustrated by twenty-two reproductions of photomicrographs, which show how the nuclei of silver salt are affected by various modifications of the times of exposure, the method of development, and the use of intensifiers and of restrainers.

The December (1907) Bulletin of the Bureau of Standards contains the results of a long investigation on the Clark and Weston standard cells, by Messrs. F. A. Wolf and C. E. Waters. They conclude that the agreement between cells set up with different samples of mercurous sulphate prepared by any of the recognised methods, or by treatment of commercial sulphate with sulphuric acid, is highly satisfactory, and suggest that the standard cell should serve as one of the two fundamental electrical standards. It has been shown that the cells now constructed can be carried long distances without changes of electromotive force of more than a few parts in 100,000 being produced. It will be seen from this statement that the results obtained in America are in agreement with those found at the National Physical Laboratory and communicated to the Royal Society a few weeks ago.

An article on some of the present problems of radio-activity, by Dr. G. A. Blanc, appears in the December

(1907) number of *Le Radium*. The author considers that Rutherford's disintegration theory is the explanation of radio-activity, and asks whether disintegration is not taking place in all forms of matter? After reviewing the evidence for the α particle being either half an atom of helium with a unit charge or an atom with a double charge, he comes to the conclusion that neither is satisfactorily established. Nor is the genealogical tree of the radio-active elements yet made out. Is it possible, he asks, that lead and silver, which are so intimately associated in nature, belong to this tree, and that one is the parent of the other? The amount of radium in the earth's crust is more than sufficient to maintain the temperature constant, and now he finds there is more thorium present than is necessary to supply the heat required. He is sanguine that some means will eventually be found which will allow us to stimulate radio-active disintegration, and thus obtain a source of energy the utility of which we can scarcely at present conceive.

THE product of the world's gold mines for the year 1906 could be all packed in a room 10 feet square and 9 feet high, says Mr. T. F. Van Wagenen in an article on gold in the current number of the *Popular Science Monthly*. The value of this 90 cubic feet of gold was nearly eighty-one and a half millions sterling, and its weight nearly 674 tons. Very nearly one-third of this amount was obtained in South Africa, about one-fifth from Australasia, and nearly a quarter from the United States and Alaska. Eighty-three per cent. of the total output was secured by the Anglo-Saxon world. According to calculations and estimates made in 1900 by the director of the United States mint, the gold taken from the mines of the world since the discovery of America has amounted in quantity to about 21,424 tons, and in value to more than 2,520,000,000. Nineteen per cent., or nearly one-fifth of the whole, has been mined in the last ten years, and 30 per cent. in the last twenty years.

MESSRS. SAMUEL BAGSTER AND SONS, LTD., have published a fifth edition of Mr. W. T. Lynn's "Astronomy for the Young."

A SECOND edition of Mr. George J. Gray's "A Bibliography of the Works of Sir Isaac Newton, together with a List of Books illustrating his Works," has been published by Messrs. Bowes and Bowes, of Cambridge. The work has been revised and enlarged, and many important additions have been made.

THE first volume of the sixth edition of A. Wüllner's "Lehrbuch der Experimentalphysik," dealing with general physics and sound, has just been received from Mr. B. G. Teubner, Leipzig. The volume contains more than a thousand pages, about seven hundred of which are concerned with the general properties of matter, while the remainder deal with wave motion and sound. The price of this elaborate treatise on the fundamentals of physics is sixteen marks.

THE "International Geography," edited by Dr. H. R. Mill, and written by seventy authors, with special knowledge of the subjects on which they contribute articles, has been re-published by Messrs. Macmillan and Co., Ltd. The work is now issued, not only in one complete volume, but also in parts. The sections dealing respectively with the British Isles, Europe, Asia, Australasia, North America, South America, and Africa can be obtained separately. The parts each contain a selection of original questions and exercises, and a miscellany of questions set in various public examinations, and they should prove of great service in the higher classes of schools.

OUR ASTRONOMICAL COLUMN.

OBSERVATION OF ENCKE'S COMET ON DECEMBER 25, 1907.—From No. 4226 of the *Astronomische Nachrichten* (p. 31, January 7) we learn that, having found Encke's comet on January 2, Prof. Wolf examined some earlier plates, and found an image of the comet on one taken at 7h. 20m. December 25, 1907 (Königstuhl M.T.). Its position at that time was R.A. = 22h. 57.4m., $\delta = +0^{\circ} 54'$, and its magnitude 13.0. Owing to its being near the edge of the plate, this image was overlooked at first. From this observation it appears that the recently published ephemeris (*Astronomische Nachrichten*, No. 4222) requires corrections of $+2.4m.$ and $-24'$.

A NEWLY DISCOVERED BRIGHT MINOR PLANET (1908 B.M.).—A comparatively bright planet was discovered by Dr. Kopff at Heidelberg on January 4. Its position at 12h. 27.6m. (Königstuhl M.T.) was $\alpha = 7h. 33m. 48s.$, $\delta = +14^{\circ} 57'$, and its daily motion $-1.4m.$ and $-20'$. The magnitude of this object was recorded as 9.2. Dr. Przybylko observed the planet with the 12-inch refractor of the Astronomischen Institut on January 5, and found it to be equal in magnitude to B.D. +14².1717 (magnitude, 9.4) (*Astronomische Nachrichten*, No. 4226, p. 31, January 7).

MEASURES OF DOUBLE STARS.—In No. 4227 of the *Astronomische Nachrichten* (p. 33, January 8), Messrs. C. P. Olivier and R. E. Wilson publish the results of 420 observations of 116 double stars made at the Leander McCormick Observatory, University of Virginia, during the years 1904-7. Seven of the doubles in this list were discovered by Mr. Olivier, and are now published for the first time. Notes as to the probable motions of some of these doubles are appended to the paper.

EPHEMERIS FOR COMET 1907e.—A bi-daily ephemeris for comet 1907e, covering the period January 13 to February 22, is published in No. 4226 of the *Astronomische Nachrichten* by Herr M. Ebell. An observation by Dr. Wirtz, made at Strassburg on December 4, gave the magnitude as 12.7.

THE ABSORPTION OF D₂ (HELIUM) IN THE NEIGHBOURHOOD OF SUN-SPOTS.—In an article appearing in the *Observatory* (p. 51, No. 392, January), Father Cortie discusses some photographs of sun-spot spectra obtained by Mr. Nagaraja at the Kodaikanal Observatory last year. The special point of these photographs was that, with a spot near the limb of the sun, they are supposed to show the bright line at the limb and the dark absorption line in the region of the spot at the same time. Father Cortie's discussion tends to show that the dark line in question is, possibly, not coincident with D₂, and is perhaps the water-vapour absorption line at λ 5875.963. He has many times recorded lines attributed to water-vapour in the spectra of sun-spots, and suggests the possibility of the presence of superheated steam in sun-spots.

In regard to the recent suggestions that a permanent dark D₂ line occurs in the solar spectrum, Father Cortie points out that Mr. Higgs and he thoroughly investigated the question seventeen years ago, and concluded that there was no permanent dark line coincident with the bright D₂; since then no conclusive evidence has been adduced to lead him to alter that conclusion.

THE ORBIT OF THE SPECTROSCOPIC BINARY θ AQUILÆ.—No. 6, vol. 1, of the Journal of the Royal Astronomical Society of Canada (p. 357, November-December, 1907) contains a preliminary set of elements for the orbit of the spectroscopic binary θ Aquilæ. This star has a photographic magnitude of 3.6, and its spectrum is of the type VIIa. Mr. W. E. Harper, of the Dominion Observatory, Ottawa, who publishes the elements, finds that Deslandres's conjecture of a 16.8-day period and a high eccentricity is confirmed. The present elements give 17.17 days as the period, -26.7 km. per sec. as the velocity, 0.725 as the eccentricity, and 8,455.50 km. as the length of the semi-major axis of the orbit.

ECLIPSE OBSERVATIONS, AUGUST, 1905.—No. 15 of the *Bulletin de l'Académie Impériale des Sciences de St. Pétersbourg* contains M. Donitch's report of the results obtained by the expeditions dispatched by the academy to

observe the eclipse of 1905. Two expeditions were organised, one going to Alcalá de Chisvert (Spain), the other to Assouan. The object of the former was to study the chromosphere and corona, whilst the attention of the latter was chiefly devoted to observations of terrestrial magnetism. In the present paper M. Donitch, who directed the expedition to Spain, discusses the purely astronomical results. Photographs of the chromospheric spectrum were obtained, and the wave-lengths and origins of some 110 lines are given in tabular form. In addition to those of H, He, Ca, Sc, Ti, Cr, Fe, Sr, Yt, and Ba, there are indications of the presence of lines of Co, Zr, Eu, and, possibly, Ge in the spectrum. The depths of the layers of these various elements in the chromosphere were measured, those of hydrogen and calcium giving the highest numbers, 49,300 kilometres and 44,000 kilometres respectively. The dimensions of five prominences as shown in radiations of various wave-lengths are also given.

The photographs of the corona show it to have been of the "maximum" type, as one would expect in 1905. Reproductions from several of the photographs obtained accompany the paper.

We have also received a finely illustrated volume containing a full discussion of the results obtained by the astronomical section of the Observatory of Cartuja, Granada, Spain. In this work, published under the direction of P. José Mier y Terán, S.J., most of the questions and theories arising from eclipse observations are discussed at length, so that the volume, which is printed in Spanish, forms a useful reference work for future observers.

SCIENCE AT RECENT EDUCATIONAL CONFERENCES.

THERE is no ebb in the tide of educational congresses. On the contrary, the number of teachers' organisations increases year by year, the number holding annual meetings during the last month in London alone running well into double figures. Nor is there any falling off in the vigour of the individual associations; indeed, in the case of the London County Council Conference, large numbers were unable to gain admission owing to the crowded state of the hall. This particular conference brought together more than twelve hundred workers in education, the majority of whom were teachers in L.C.C. elementary and secondary schools and technical institutes. We propose to review this meeting and that of the Public Schools Science Masters' Association, but desire to preface a few remarks on the effect of the multiplication of societies for the furtherance of various branches of education.

The time has gone by when a schoolmaster was expected to be able to teach all the subjects of the curriculum. Improved methods of teaching have in every subject called for a greater mastery on the part of the teacher, so that just at present we appear to be saved from having a specialist for every subject in the curriculum solely by considerations of financial economy. The science master teaches nothing but science, and is apt to lose interest in, and to be out of touch with, other subjects, and, *mutatis mutandis*, this is true of the modern language master and of the others. Hence we find segregation of teachers into their respective associations, each dealing with its particular branch of study. The advantages of these independent meetings are not far to seek. If the discussion refers to the teaching of physics, for example, the whole audience may be assumed to have some expert knowledge and to be intimately concerned in arriving at a right judgment. The informal and social side of the meetings, not their least valuable function, may be easier to promote, because each feels that he can exchange views with his neighbour to their mutual profit. But there are drawbacks to this segregation. Nothing was more frequently insisted on during the debates of the Public Schools' Science Masters than the need for cooperation between the teachers of mathematics and physics. One speaker urged that nominees of the Public Schools' Science Masters' Association should confer with nominees of the Mathematical Association to promote this end. In our opinion, this proposal falls very short of what is required. It would be better to hold a joint general meeting of the

two associations, which would be better calculated to lead to an appreciation on the part of individual members in each body of the aims and difficulties of their colleagues in the allied camp. It would be easy to suggest other joint meetings of associations which would be helpful just now. Sections of the British Association unite to discuss problems on their boundaries, and this with better effect than by joint committees. Moreover, the various sections of the British Association belong to one body, and the general public recognises the importance of conclusions carrying its imprimatur. Would not teachers have more public influence if the existing associations were federated? The specialising influence to which we have referred should not be allowed to become a narrowing influence, and to that end teachers should from time to time hear addresses from first-rate men on subjects outside their own branch. The influence of science is probably weakened at the present time by the confinement of all scientific subjects to a technical society or body of experts. Science was practically omitted from the agenda of all the educational conferences this winter, except of the two which we will now describe.

LONDON COUNTY COUNCIL CONFERENCE.

The subjects dealt with fall under the four heads nature-study, commercial education, manual work, and pedagogic experiments, and we will omit all further reference to the second of these.

"The Place of Nature-study in the School Curriculum" was the title of the opening paper by Dr. Percy T. Nunn, and it would be difficult to imagine a better introduction than the philosophical exposition given by the vice-principal of the London Day Training College. The basis of Dr. Nunn's arguments was the principle that it is the business of the educator to cultivate groups of interests rather than to teach useful subjects. While recognising that nature-study could well contribute to the aesthetic side of the curriculum, it had clearly to be recognised on the whole as an integral part of the instruction in science. The science curriculum should be so thought out as to secure continuity of development in conformity with the characters which distinguished the successive levels of the scientific process. Of these levels or stages, the highest and latest was the stage of system pursued for its own sake, a stage scarcely reached at school by ordinary pupils. Before this was the utilitarian stage, in which the greater part of elementary science teaching should fall. The foundation should be the nature-study stage, in which "science is born of wonder." These stages were not separable by clear lines of demarcation, and it was a mistake to allow their continuity to be interrupted, as when topics introduced in the nature-study lessons were afterwards allowed to drop. In the case of rainfall, for instance, the first simple studies should lead through the investigation of dew-point to hygrometry, the measurement of vapour-pressure, and thence to the doctrine of the continuity between liquids and gases. Dr. Nunn stated, in conclusion, that science of the higher type could not be a completely healthy growth unless it sprang out of the foundation of nature-study. The papers which followed, on school excursions, and the use of the school museum, dealt with practical points in the management of these aids to teaching. Both authors and subsequent speakers emphasised the importance of observations being made under conditions as little artificial as possible. The superiority of open-air work was generally admitted, but, in addition to difficulties with regard to time and place, some speakers found obstacles in the regulations under which they worked.

The afternoon discussion was practically confined to the subject of botany teaching in girls' schools. Miss Lulham discussing the approach to the subject through nature-study, Miss Lilian Clarke describing the botanical laboratory and school gardens at Dulwich, and Miss von Wyss tackling the difficult problem of teaching large classes in elementary schools. Space does not permit us to enter into detail, so we must content ourselves with stating that each of these papers bristled with practical suggestions based on actual experience, and suited to ordinary conditions of work, where the pupils are many and the time circumscribed. We may remind our readers that a

verbatim report of the conference will be issued by the County Council, and advise teachers working with strictly limited funds and a lack of cupboards and other fittings to study the very helpful recommendations made by Miss von Wyss. It is not surprising that, stimulated by her teaching, a natural history club could be started and be continued as an evening class after leaving school in a district which at first sight appeared unpromising. In passing, we may note that Miss Lulham pointed out the virtues of colt's-foot as a plant for all-the-year-round study by beginners, so we may bless as teachers the persistent weed which as gardeners we are disposed to ban. In the discussion the papers met with hearty approval, an inspector of secondary schools pointing out that many important girls' schools had given up botany after trying to teach the subject on wrong lines. There was general agreement that the study of botany became highly interesting and educative if the following conditions were fulfilled:—(1) the living plant must be studied; (2) the pupils must keep plants under observation for lengthened periods, making notes and diaries illustrated by their own sketches direct from nature; (3) the pupils must experiment; (4) the teacher must prepare the lessons very carefully, and then leave as much as possible to be done by the pupils themselves. The moral and aesthetic influences of the study of nature were not forgotten, and it was rightly pointed out that the teacher must not forget that plants are living and beautiful. Is it too much to hope that a love of nature may attract youngsters to healthier interests than those stimulated by the poor silly trash which is so much read?

Sir John Cockburn presided at the discussion on manual training, and pointed out its importance from the physiological standpoint. Motor instruction conformed to natural methods, and the moment these methods were departed from the work of the teacher became a distortion of what it should be. The brain could only be built up properly through the action of the muscles. Dr. Slaughter, late assistant to Dr. Stanley Hall, read a paper on the need of manual training in the lower standards, in which he insisted on the idea of training all classes for citizenship. Scientific investigation showed that the human body was no longer to be regarded as separate from the human mind, and that thought was truncated action. He based his hopes for the future of education on manual training, although present methods were open to serious criticism. Perhaps their greatest fault was that they aimed too much at the acquisition of technique, whereas such training should be in daily use for its adaptive educational value. It should mean more than hand training, should make use of drawing, and should give knowledge about geography, animals, and plants. Mr. J. C. Hudson gave an account of manual work in American elementary schools, some making it merely supplementary, whilst others use it as a means of correlating all subjects. Perhaps the underlying idea may be indicated by the substitution of the terms "expression work" and "associative activities" for the term "manual training." Mr. P. B. Ballard considered the position of manual work in Standards I. to IV. of the senior departments of English elementary schools. As the result of a recent inquiry, he obtained replies from 120 educational authorities, which showed that only sixteen authorities adopted a systematic course of hand-work. As regards London, courses in brush-work, clay-modelling, &c., were rare, except in the special schools for the mentally and physically defective, so that in the matter of motor training the lost sheep was looked after and the ninety and nine forgotten. Mr. Ballard proceeded to advocate the application of hand-work to ordinary school subjects, and gave a series of illustrations of his ideas as applied to arithmetic, geography, and history. He wished to bridge the gap at present existing between the kindergarten occupations of the infants' department and the manual and domestic work of the senior standards.

During the sitting devoted to educational experiments in elementary schools, a paper was read by Mr. H. J. Hazlitt, in which the author described in detail how he had been conducting classes in open-air geography. By making previous provision of home-made survey maps and notes, the class was able to take an enlightened interest

in an excursion to Crowhurst. Open-air work gives a genuine foundation to the study of geography, and thereby that essential factor, the map, can be properly understood.

PUBLIC SCHOOLS' SCIENCE MASTERS' ASSOCIATION.

The salient features of the annual meeting, held at Westminster School on January 14, were:—(1) the address from Prof. H. A. Miers, F.R.S.; (2) the instructive exhibition of apparatus; (3) the discussion on the position of mechanics in the physics course; (4) the repeated expression of the need for cooperation between the masters responsible for mathematics and physics respectively.

Prof. Miers took as his subject the order in which scientific ideas should be presented. He deprecated any rigid division of science into subjects, and believed that harm had resulted from attempts to keep mathematics, physics, and chemistry apart from each other, and to confine them to separate teachers. He desired to leave freedom to the individual teacher as regards method, but felt that as regards order there should be more system in our science teaching. In other subjects there was an advantage in having a recognised order based upon prolonged experience, and science should stand upon the same level as languages and mathematics in our schools, and should form an integral part of any liberal education. It was not easy to find out at the moment what the pupil understood of the instruction, and where he had succeeded in analysing the difficulty of a pupil he generally discovered that he himself was at fault in having presented ideas in the wrong order, and assumed something which was not yet familiar to the pupil. He found a useful guide to the proper order in the succession in which the ideas of a science had been developed in its past history.

Prof. Miers advocated nature-study in the wide sense; the boy should be taught to notice the ordinary objects and events of his own world, and to draw scientific nourishment therefrom, including in his intelligent observation all that was going on around, and not merely the processes of nature familiar in country life. If only the ordinary boy could get into his head the notion that science was the intelligent study of ordinary things, he would cease to regard it as a mere educational task. It was unwise, if not impossible, to teach chemistry and physics as independent subjects. In the preparatory school the boy should be trained in observational work, which would impart information useful in the experimental science that was to come next. The systematic teaching at a public school should from the outset be experimental, and the spirit of inquiry should be cultivated, and scientific dogmatism guarded against.

Coming to the university teaching of science, we had now to deal with mature minds, and the spirit of research should absolutely dominate the teaching. There was nothing better for encouraging research than natural history, which was admirably suited for advanced study at the university. Original papers were more stimulating than text-books, and there is need for an English series reproducing the original researches of highest importance, perhaps with the translation of archaic expressions into modern equivalents. Lectures should follow the historical order, laboratory work the method of research.

Prof. Armstrong felt it to be a deplorable fact that science had lost ground in public estimation. We felt the absence of Huxley and Playfair, and it rested with the public schools to carry the banner forward. The Davy-Faraday laboratory had, with one exception, failed to attract the gilded youth, fired with enthusiasm for science by their work in public schools. We must teach so as to excite more interest, so as to make that interest more continuous and permanent, and so as to cultivate, not powers of observation only, but the faculty of keen, intelligent criticism also. He held that Germany had achieved her position owing to the cultivation of originality by her universities.

The other papers read during the meeting were:—(1) the educational value of mechanics, by Mr. C. F. Mott (Giggleswick); (2) the teaching of practical mathematics, by Mr. H. Wilkinson (Durham); (3) scheme for laboratory work in physics, by Mr. Cumming (Rugby); (4) a suitable physics curriculum for the first and second years, by Mr. W. E. Cross (Whitgift); (5) the compulsory teaching of

elementary physics to junior forms, by Mr. J. M. Wadmore (Aldenharn).

In the course of the discussions, it was pointed out that there is a great leakage from schools of boys who are under the proper leaving age, and that such boys necessarily receive little scientific education. There was no lack of enthusiasm for science on the part of boys who fulfilled the course of instruction. The fact that boys were promoted in many schools without regard to their science work placed difficulties in the way, such as were met by re-arranging the schools in sets in the case of mathematics. The study of scientific mechanics might be postponed until boys had obtained some experience in general experimental physics; practical work in heat could be introduced earlier. Boys should be allowed to use modern electrical plant, such as the cheaper voltmeters and ammeters now available through being put on the market for motorists. Mr. Cross advocated the abandonment of the usual exercises in mensuration and Archimedes's principle, and the substitution of a course of experimental construction of working cranes, &c. He would devote the first two years to such work, which stimulates interest and leads to a grasp of principles, e.g. the inquiry into the transmission of power by belts leads to true notions about energy and friction. It is a pity that there was little criticism of this interesting and unorthodox paper, for there is no doubt that most boys want to know "how it works"; moreover, the course which Mr. Cross outlined can readily fulfil Prof. Miers's requirement that the application of the instruction to everyday life should be straightforward. The relative merits of working collectively or individually in the laboratory were discussed, and Mr. Cumming claimed that the former system proved successful at Rugby. In summing up the discussion, Prof. Miers remarked upon the extreme diversity of methods adopted in different schools.

The exhibition of apparatus attracted well-deserved attention. Several dealers in apparatus, and some of the leading publishers, sent extensive exhibits, but the most gratifying, and in many respects the most instructive part of the exhibition was the ingenuity of the home-made contrivances sent from a good number of schools. We must congratulate and thank those responsible, and particularly Mr. D. J. P. Berridge, to whose organisation much of the success of this feature of the meeting was due. There were so many items of interest that it is impossible to describe them all, and it seems invidious to select. On the score of daring simplicity, we may perhaps award the palm to a motor armature shown by Mr. C. J. L. Wagstaff, which consisted of a bottle-cork, a few turns of insulated wire, and a dozen pins. Dr. T. J. Baker reached the acme of simplicity in his supports for prisms, lenses, &c. These were mounted by being stuck in their appropriate positions into lumps of plasticine—*voilà tout!* We would suggest to the management the advisability of printing a large number of copies of the catalogue; they might be put on sale; in any case their wider diffusion would help to improve experimental teaching by simple apparatus of homely invention and make.

G. F. DANIELL.

THE INTERDEPENDENCE OF MEDICINE AND OTHER SCIENCES.¹

AN historical sketch, necessarily brief and inadequate, of some of the principal phases in the reciprocal relations between medicine and the physical sciences, up to the time when the latter became fully independent at the close of the seventeenth century, will show with what propriety medicine has been called the "mother of the sciences."

Physical science has derived from the Greeks no such extensive records of sound observation and experience as those which medicine has inherited from the writings of Hippocrates and his followers. Physical theories embodied in the speculations of the nature-philosophers concerning the constitution and properties of matter furnished the

¹ From an address delivered by Dr. W. H. Welch, professor of pathology, Johns Hopkins University, Baltimore, as the retiring president of the American Association for the Advancement of Science, at Chicago, December 30, 1907.

starting point for the Hippocratic doctrine of the four humours and other generalisations, but these theories sat so lightly upon Hippocrates that his name is attached to that method of medical study which rejects dogma, authority, and speculation, and confines itself to the observation and record of clinical facts. As Gomperz in his admirable work on the "Greek Thinkers" has clearly pointed out, the age of enlightenment in scientific thought was inaugurated by Hippocrates and his medical contemporaries.

The influence of physical theories upon medical thought in antiquity can be traced, not only in the humoral doctrines of Hippocrates and of Galen, but also in rival schools, and especially in the so-called methodic school founded upon the atomistic philosophy of Democritus, which is so interesting in the history of scientific theories. As this school produced such admirable physicians as Asclepiades, Soranus, and Aretreus, it is to be regretted that their solidistic pathology was so completely displaced by the authority of Galen.

The large body of medical knowledge and doctrine which had grown up during the six centuries since Hippocrates was further developed and fixed by Galen at the end of the second century after Christ into a system not less complete in its field, nor less satisfying to the minds of men for nearly fifteen centuries, nor scarcely less remarkable as a product of the human mind than the physical and philosophical systems of Aristotle. Within their respective spheres the system of doctrine of each of these great men has exerted a similar dominating influence upon human thought, and has met a similar fate through influences almost identical.

The great awakening of western Europe, marked by the revival of learning and the Reformation, stirred the long dormant spirit of inquiry and led to revolt against authority, a fresh outlook upon a wider world, the study of original sources, the questioning of nature at first hand, and the search for new knowledge in all her kingdoms. The seat of learning was transplanted from the cloisters to the universities, which multiplied and flourished in the sixteenth and seventeenth centuries as never before.

In the sixteenth century practically all the valuable contributions to botany and to zoology were made by physicians, so that natural history scarcely existed apart from medicine. Of the medical contributors to botany, it must suffice to mention the names of Brunfels, Fuchs, Dodoens, Gesner, and, above all, Cesalpino, who has been called "the founder of modern scientific botany," the most important name before John Ray in the history of systematic botany, and a distinguished figure likewise in medical history. Of names associated with the history of zoology in this century, the most important are those of the physicians, Conrad Gesner, a marvel of encyclopædic learning, and Aldrovandi, who ranks with the founders of modern zoology and comparative anatomy; of lesser lights Edward Wotton may be singled out for mention as the pioneer English zoologist. He was doctor of medicine of Padua and of Oxford, president of the Royal College of Physicians, and physician to Henry VIII.

A name of the first rank in the history of science is that of the physician, Georg Agricola, who founded before the middle of the sixteenth century the science of mineralogy, and developed it to a state where it remained for nearly two hundred years without important additions.

The student of medical history who takes up a history of physics will probably be surprised to find how many of the contributors to the latter subject in the sixteenth century were physicians, and that among these are such old friends as Fernel and Fracastorius, whom he has identified so intimately with the annals of his profession. It is to be presumed that he already knew that the most famous of all, Copernicus, was a doctor of medicine of Padua, and practised the medical art gratuitously among the poor in Frauenburg.

Far more important for the subsequent history of science than any relations between medicine and physics at this period was the union between medicine and chemistry effected by Paracelsus, and strengthened by van Helmont and Sylvius in the following century, a union so intimate that for nearly a century and a quarter chemistry existed only as a part of medicine until freed by Robert Boyle

from bonds which had become galling to both partners. The story of this iatro-chemical period, as it is called, has been told by Ernst von Meyer in his fascinating "History of Chemistry" in a way not less interesting to the student of medicine than to one of chemistry, and should be there read by both.

William Gilbert, second in importance only to Galileo among the creators of experimental science, the founder of the science of magnetism, and a significant name in the history of electricity, was fully identified with the medical profession, being the most distinguished English physician as well as man of science of his day, physician to both Queen Elizabeth and James I, and president of the Royal College of Physicians.

Galileo's younger contemporary, William Harvey, the discoverer of the circulation of the blood, occupies in the history of experimental science an independent position quite unlike that of the other experimental physiologists of the century. These other physicians, as Sanctorius, Borelli, Lower, Mayow, consciously took possession of the method of experiment as a powerful and newly discovered instrument of research, and were swayed in all their physiological work by the discoveries of the physicists. Not so Harvey, who was influenced but little by contemporary physical science, and is linked on, not to Galileo or to Gilbert, as exemplars of experimentation, but in a very direct way to the experimental physiologist, Galen, and to Aristotle, as well as to the Italian anatomists of the preceding century. Harvey's genuinely scientific mind was in greater sympathy with Aristotle than with the essentially unscientific Lord Bacon, who was his patient, and of whom he said, "He writes philosophy like a Lord Chancellor."

Descartes was an anatomist and physiologist as well as philosopher, mathematician, and physicist, and John Locke, the other great liberator of thought in this century, was educated in medicine, practised it, and, like Boyle, accompanied Sydenham on his rounds. Kepler studied the pulse, contributed to physiological optics, and calculated the orbits of the planets. Borelli was an important mathematician, physicist, and astronomer, as well as one of the greatest physiologists and physicians of the century. Bartholinus was also professor of mathematics as well as of medicine, and discovered the double refraction of Iceland spar. His even more remarkable pupil, Steno, left a name memorable in geology and palæontology, as well as in anatomy and physiology, and died a bishop of the Roman Catholic Church. Mariotte, a pure physicist, discovered the blind spot in the retina. Boyle anatomised, experimented on the circulation and respiration, started chemistry on new paths, and perpetuated his name in attachment to an important physical law. Hooke, most versatile of all, claimed priority for a host of discoveries, and did, in fact, explore nearly every branch of science with brilliant, though often inconclusive, results. Malpighi was an investigator equally great in vegetable and in animal anatomy and physiology, and what a glorious time it was for the microscopists, like Malpighi, Leeuwenhoek, Swammerdam and others, who could immortalise their names by turning the new instrument on a drop of muddy water, or blood, or other fluid, or a bit of animal and vegetable tissue!

After the seventeenth century in Europe the natural sciences, though often cultivated by those educated in medicine and practising it, were independent, and followed their own paths, which, however, communicated by many by-ways with the road of medicine and with each other.

Botany and zoology acquired their independent position probably more through the work of Ray and Willughby than by that of any other naturalist. Botany, however, remained for more than a century still mainly in the hands of physicians. An interesting chapter in its history is the story of the various apothecaries' and other botanical gardens established through the efforts of physicians, and conducted by them primarily for the study of the vegetable materia medica. From such beginnings has grown the Jardin des Plantes in Paris, started by two physicians, Herouard and la Brosse, in 1613, into the great museum of natural history made by Buffon, Cuvier and others as famous for the study of zoology as by the de Jussieu and by Brongniart and his successors for botany. Less

humane was the foundation of the British Museum and its appanage, the great Museum of Natural History in South Kensington, the gift to the nation of his valuable collections in natural history and other departments by Sir Hans Sloane, a leading London physician in the first half of the eighteenth century.

Aspects of my subject, full of interest, which I can now barely touch upon, are the influence of previous medical or biological training upon the work of a physicist or chemist, and closely connected with this the extent to which purely physical problems have been approached from the biological side. Call to mind how the central physical and chemical problem of the eighteenth century, the nature of combustion, was throughout this period intimately associated with the identical physiological problem of respiration, and how John Mayow in the seventeenth century, approaching the subject from the biological side, reached a conclusion in accord with that fully demonstrated a century later by Lavoisier, who thereby opened a new era for physiology as well as for chemistry. For the first time clear light was shed upon the function of respiration, the nature of metabolism, and the sources of animal heat, and such physical interest was attached to the study of these physiological phenomena that physicists of the rank of Laplace, in association with Lavoisier, Dulong, W. E. Weber, Magnus, A. C. Becquerel, Hirn, Regnault, and of course Helmholtz, have all made valuable contributions to the elucidation of these subjects.

The study of electricity, especially after the physiologist Galvani's epochal discovery, more correctly interpreted by Volta, engaged the attention of physicians and physiologists scarcely less than that of physicists. The latter became greatly interested in animal electricity, a subject partly cleared up by the physicists Ritter and Nobili, but mainly by the physiologist Du Bois Reymond.

There is no more striking illustration of the correlation of two apparently distinct lines of approach to the same problem than the attack from the biological and from the purely physical sides upon the thermodynamic problem, which is as fundamental for biology as for physics. The conception of the principle of conservation of energy was supplied independently and almost simultaneously, on the one hand, by students of the conditions of mechanical work done by the animal machine, and on the other by investigators of technical machines. Much of the essential preliminary study was on the biological side by Boyle, Mayow, Black, and Lavoisier. Mainly from the same side the physician and physicist, Thomas Young, first formulated the modern scientific conception of energy as the power of a material system to do work. Davy and Rumford contributed, and from the physiological side Mohr, Mayer, and Helmholtz, and from the purely physical side, after preliminary work by Poncelet and Sadi-Carnot, Joule, Thomson, and Clausius reached the same grand conception. The first to enunciate clearly and fully the doctrine of the conservation of energy and to measure the unit of mechanical work derived from heat was the physician J. R. Mayer. Joule's work completed the demonstration, but Mayer's name is deservedly attached to this principle by Poincaré and others, as Lavoisier's is to that of the conservation of mass, and Sadi-Carnot's to the principle of degradation of energy. As regards this last principle, it is almost as interesting to biologists as to physicists that in the so-called Brunonian movement, discovered by the physician and more eminent botanist Robert Brown, and the subject of interesting physical investigations in recent years, we behold an apparent exception to the principle of degradation of energy, such as Clerk Maxwell pictured as possible to the operations of his sorting demon.

I must forego further citation of examples of this kind of correlation between the work of physicists and of physiologists, and leave untouched the chemical side, which is much richer in similar illustrations. The significance to organic chemistry of the synthesis of urea by Wöhler, and to agricultural chemistry of the bacteriological studies of nitrification in the soil and fixation of nitrogen in plants, will perhaps indicate how large and fascinating a field I must pass by.

The light which has transformed the face of modern practical medicine came, in the first instance, not from a

physician, but from a physicist and chemist, Pasteur. The field of bacteriological study thus disclosed was placed on a firm foundation and thrown open to ready exploration by Robert Koch, and thereby that class of diseases most important to the human race, the infectious, became subject in ever-increasing measure to control by man. Thus hygiene and preventive medicine, through their power to check the incalculable waste of human life and health and activities, have come into relations, which have only begun to be appreciated, with educational, political, economic, and other social sciences and conditions, and with the administration of national, State, and municipal governments. It is an especial gratification to record the stimulating recognition of these relationships by the social and economic section of this association, in which was started a year and a half ago a movement for public health, particularly as related to the Federal Government, which has already assumed national significance.

To the marvellous growth of the medical and other sciences of living beings during the past century, and especially in the last fifty years, physics and chemistry and the application of physical and chemical methods of study have contributed directly and indirectly a very large and ever-increasing share. In many instances there is no telling when or where or how some discovery or new invention may prove applicable to medical science or art. Who could have dreamed in 1856 that Sir William Perkin's production of the first aniline dye should be an essential link in the development of modern bacteriology, and therefore in the crusade against tuberculosis and other infectious diseases? As Robert Koch has said, it would have been quite impossible for him to have developed his methods and made his discoveries without the possession of elective dyes for staining bacteria, and colouring agents of no other class have been discovered which can serve as substitutes for the anilines in this regard. And how much assistance these dyes have rendered to the study of the structure and even the function of cells! If we trace to their source the discovery of Röntgen's rays, which have found their chief practical application in medicine and surgery, we shall find an illustration scarcely less striking.

No important generalisation in physical science is without its influence, often most important, upon biological conceptions and knowledge. I have already referred to the great principles of conservation of mass and of energy which are at the very foundation of our understanding of vital phenomena. Although we cannot now foresee their bearings, we may be sure that the new theories, regarding the constitution of what has hitherto been called matter, will, as they are further developed, prove of the highest significance to our conceptions of the organic as well as of the inorganic world.

The ultimate problems of biology reside in the cell. Whatever the future may hold in store, at the present day only a relatively small part of these problems are approachable by physical or chemical methods and the day is far distant, if it ever comes, when cellular physiology shall be nothing but applied physics and chemistry. We cannot foresee a time when purely observational and descriptive biological studies, which to-day hold the first place, shall not continue to have their value. They represent the direction which makes the strongest appeal to the great majority of naturalists. The broadest generalisations hitherto attained in biology, the doctrine of the cell as the vital unit and the theory of organic evolution, have come from this biological, as distinguished from physical, direction of investigating living organisms, and were reached by men with the type of mind of the pure naturalist, who loves the study of forms, colours, habits, variations, adaptations, inheritances of living beings.

It is well that the sciences of nature hold out attractions to so many different types of mind, for the edifice of science is built up of material which must be drawn from many sources. A quarry opened in the interest of one enriches all of these sciences. The deeper we can lay the foundations and the farther we can penetrate into the nature of things, the closer are the workers drawn together, the clearer becomes their community of purpose, and the more significant to mankind the up-building of natural knowledge.

RAINFALL AND WATER-SUPPLY.¹

IT happens that rainfall is not only the most difficult of all the meteorological distributions to map accurately, it is also that one which is of the greatest importance, for by rain the rivers are fed, and the rivers both water and drain the land. Every year makes clearer the vast national importance of accurate knowledge of the rainfall of a county, for the problem of the rivers is becoming acute. The growing populations of the great towns are tapping the upper waters and diverting the water from its natural channels, and at the same time they are polluting the lower courses with the waste of the factories and the streets. Toll is taken all along the banks of industrial streams for raising steam and carrying on the multitudinous processes of manufacture. There is sometimes anxiety as to whether the waterways can be kept sufficiently supplied to float the water-borne traffic or to fight the silting action of the tides, and there is growing alarm as to the possibility of fish traversing the depleted and polluted streams to reach their spawning beds.

Of recent years, the value of the water-power which may be generated in the lonely and lofty places amongst the western heights of Great Britain, where the rainfall is large and unfailling, has been recognised, and chemical works for the production in electric furnaces of what a few years ago were rare substances are becoming familiar features in Wales and the Highlands. In Ireland, too, the rainfall is an unrecognised source of wealth which as yet has not been drawn upon to any appreciable extent. The increasing strenuousness of the struggle for the possession of large water supplies is producing in England, and especially in Wales, a great amount of local jealousy and strife, for the boundaries of parishes and counties coincide but rarely with water-partings, and the argument has been brought forward again and again that the rainfall of one county should not be diverted for the use of the inhabitants of another. The feeling is intensified when the boundary to be crossed is that of a historical division of national importance, like the boundary between England and Wales, but the map-study of rainfall can do something to suggest the lines on which such disputes should be settled.

Although the exceptional deluges of a thunderstorm or a great depression fall with equal and impartial heaviness on the hills of the west or the flat plains of the east, the common every-day rains are precipitated on the high lands and in the mountain valleys which cross the track of the prevailing wind in much greater abundance than on level and low stretches of country. Most of the rain is borne to our islands from the Atlantic, and when it comes torrentially it is of the air, and no boundary checks it; the largest annual falls come down on and near the watersheds, because there the land produces its maximum influence as a rain compeller.

From the high ground the rivers seek the plains, carrying off the excess of rainfall into the less liberally watered districts. The Dee, the Severn, the Wye, and the Usk restore to England part of the rains which the Welsh mountains have abstracted as the air passed over them. The high rainfall of the whole Pennine district, sometimes by circuitous routes across the comparatively dry plains of the east, swells the volume of fresh water that pours into the Humber. The Thames itself receives the comparatively high rains of the Cotswolds, the Chilterns, and the Downs, and forwards the water slowly through less and less rainy districts, until it reaches the sea in the driest part of England. Thus, I think, at least as good an argument can be drawn from this consideration of physical geography in favour of supplying the great towns of the east from the large precipitation of the west as can be drawn in the opposite sense from the artificial divisions of political geography. Care for the water supply of the country, coming as it does from the air that knows no bounds across the land, is by no means a parochial, but in the fullest sense a national matter, and should be dealt with in the interests of the nation as a whole, the units of subdivision, when such are required, being the natural units of river-basins.

UNIVERSITY AND EDUCATIONAL INTELLIGENCE.

CAMBRIDGE.—The Senate has approved the affiliation of the University of Bishop's College, Lennoxville, Quebec, under the conditions laid down in the report of the council of the Senate dated November 25, 1907.

The Senate has assigned a site on the Downing ground, situate to the south of the botanical laboratory and parallel to it, for a building in connection with the Department of Agriculture.

Dr. James, Provost of King's College, has been appointed a member of the council of the National Trust for Places of Historic Interest or Natural Beauty.

The special board for physics and chemistry reports that the prize of 50*l.* from the Gordon Wigan fund for an investigation in chemistry was awarded in the year 1907 to F. Buckley, of Sidney Sussex College, for his essay entitled "A Study of some Quinquevalent Cyclic Nitrogen Compounds."

MANCHESTER.—A communication has been received from the Treasury intimating that to remove any uncertainty which may prevail in regard to the arrangements of the University during the current session, a special grant of the same amount as that paid before the proposed reduction, viz. 12,000*l.*, will be made to the University for the current year. The question of the future distribution of the Treasury grant is left open for decision after the Chancellor of the Exchequer has consulted the Advisory Committee which deals with grants to universities and colleges.

MR. F. M. SAXELBY, head of the department of mathematics at the Technical College, Belfast, has been appointed to a similar position at the Battersea Polytechnic.

In the *Engineer* of January 17 is published the first instalment of a series of articles on the training of engineering apprentices, describing the methods followed at a number of works. The result of the inquiry has to a great extent been disappointing. No real general upward movement in the training of apprentices has been observed, and, with the exception of a few firms, the old indifferent method of training by hazard still obtains.

THE Government of Mysore has, the *Pioneer Mail* states, made public the new rules for regulating the grant of scholarships for scientific research and technical education from the Damodar Dass charities fund. The scholarships will be open to all Indians who have taken with credit a degree in arts, medicine, or engineering in an Indian or other recognised university. Each candidate selected will be given travelling allowance to England or elsewhere from Bangalore on the completion of his course of study or research. He will be allowed, during his stay in England or elsewhere, outside India, a sum of 200*l.* per annum, this allowance to be inclusive of college fees, cost of books, instruments, and boarding charges.

LORD AVEBURY was formally installed as Lord Rector of St. Andrews University on January 16, and delivered his rectorial address. Lord Avebury, during the course of his remarks, said there never was a time when St. Andrews was more adequately equipped, had a more distinguished list of teachers, and a curriculum more generous, wider, and less one-sided. The question is not, as is sometimes alleged, between a scientific and a classical education. No scientific man wishes to exclude classics. No degree should, in the opinion of scientific men, be given without demanding some classical knowledge. A man who is entirely ignorant of the classics, even if he is a profound mathematician, biologist, chemist, or geologist, is but a half-educated man. But the same is true even of the profoundest classical scholar who knows nothing of science. Science is of vital importance in human life; it is more fascinating than a fairy tale, more brilliant than a novel, and anyone who neglects to follow the triumphant march of discovery is deliberately rejecting one of the greatest gifts with which we have been endowed.

The prospects of a university for Bristol were much discussed at the annual dinner last week of the Bristol University College Colston Society. The financial posi-

¹ From the presidential address delivered before the Royal Meteorological Society on January 15 by Dr. H. R. Mill.

tion was explained by Mr. J. W. Arrowsmith. Eight or nine years ago, about 400l. was collected yearly to forward higher education in Bristol, and the amount is now nearly 600l. per annum. In all, the society had collected a sum of 4732l. Speaking as to the University itself, Mr. Arrowsmith said the promise of Mr. H. O. Wills, announced in NATURE last week, was satisfactory to all, and all welcomed it very heartily and with deep gratitude to Mr. Wills. But the 100,000l. gift is not everything. The amount aimed at before the Privy Council is asked for the charter is 250,000l. The aggregate sum of 30,000l. was promised at the dinner a year ago. The sums were:—Lord Winterstoke, 10,000l.; Mr. J. S. Fry, 10,000l.; Mr. Frederick Wills, 5000l.; and Mr. F. J. Fry, 5000l. Adding for buildings and endowments in connection with University College the sum of 55,000l., a total of 85,000l. is reached. Add to that the 100,000l., and 185,000l. is obtained. Mr. Arrowsmith said that a friend, since he had been in the building, had added another 10,000l., giving a total in hand or promised of 195,000l. It is obvious, therefore, that a sum of 55,000l. must be secured before the charter can be sought. Four sums each of 1000l. from Mr. Charles Thomas, Mr. Edward Robinson, Mr. Hiatt Baker, and an anonymous benefactor have also been offered. It should not be long, therefore, before the quarter of a million required for the university is raised by the men of wealth in Bristol who realise the value of higher education.

SOCIETIES AND ACADEMIES.

LONDON.

Royal Society, December 12, 1907.—"The Effects of Temperature and Pressure on the Thermal Conductivities of Solids. Part ii. The Effect of Low Temperatures on the Thermal Conductivities of Pure Metals and Alloys." By Prof. C. H. Loos, F.R.S.

The object of the work described in the present paper was to extend the measurements of thermal conductivities of metals and alloys made by Lorenz, Jäger, and Dieselhorst and others at temperatures between 0° C. and 100° C. down to the temperature of liquid air, and thus provide a means of comparing the thermal and electrical conductivities of these substances over a much wider range of temperature than has hitherto been possible. The method adopted was a modification of that used originally by Wiedemann and Franz.

The results obtained are tabulated, together with those given for higher temperatures by Jäger and Dieselhorst, and they justify the following statements:—

(1) The thermal conductivities of most pure metals decrease as the temperature rises within the range -160° C. to 100° C.

(2) The thermal conductivities of all alloys tested increase as the temperature rises within the range -160° C. to 100° C.

Institution of Mining and Metallurgy, January 16.—Prof. William Gowland, president, in the chair.—The Vaal River diamond diggings: Mungo Park. A brief description of the diamondiferous terrace deposits flanking the course of the Vaal River. The author stated that the diamonds obtained from the river gravels are, taken collectively, probably the finest stones obtainable, averaging about 6l. per carat as sold to buyers on the diggings. Methods of working these deposits, and a few notes on the general conditions of digging, are dealt with in this short paper.—The eruptive diamond-bearing breccias of the Boshof district, South Africa: J. P. Johnson. A paper describing the three occurrences of diamond-bearing rock in the district, principally from a geological point of view. Special attention is directed to the lherzolite and eclogite boulders, which contain in proportionate abundance all the characteristic minerals of the eruptive diamond-bearing breccia, and which the author thinks are the more resistant portions of a rock which has gone to form the bulk of the breccia, and was the real home of the diamond. This lherzolite-eclogite rock may exist either as a widespread consolidated formation occurring at great depths or as a deep-seated molten magma, the former condition being more likely. The author can see nothing

in the breccia other than a purely fragmentary formation, nor has he been able to detect traces of contact metamorphism either of the walls of the vent or of the included boulders. He concludes, therefore, that the type of volcanic phenomenon producing the peculiar features of these diamond-bearing vents would be a geyser rather than a volcano, more especially as there is not the least evidence of any molten rock or lava having passed through them.—The auriferous banded ironstones and associated schists of South Africa: Owen Letcher. Five principal mines working in the banded ironstone beds and associated schists are passed under review in turn under the following heads:—salient geological features; occurrence of gold in the formation; methods of mining and productive and economic values; and metallurgy of the series. The author points out that these banded ironstones are the oldest known auriferous sedimentary rocks in South Africa, lying between the basement schists and the conglomerate series, and he considers that on account of what is at present known as to the great width of the gold-bearing formation, the occurrence of gold in many places in payable quantities, and the amenability of the ores to a simple method of treatment, the exploitation of mines in the series is likely to assume considerable importance in future South African history.

PARIS.

Academy of Sciences, January 15.—M. Henri Becquerel in the chair.—Note on the density of graphite: H. Le Chatelier and S. Wologdine. On account of the wide range of densities which various experimenters have given for graphite, it has been assumed that graphite is not a single variety of carbon, although this is contradicted by the constancy of the heat of combustion of purified graphite. The authors have examined the following:—Acheson graphite (artificial); graphite from Ceylon, Australia, Bohemia (Mugrau and Scharzbach), Greenland, commercial graphite, and from cast iron. The method employed was flotation in a heavy liquid (mixture of acetylene bromide and ether), care being taken to eliminate all air bubbles. The figures for the unpurified material from these sources varied between 1.62 and 2.66. Purification by Moissan's method was then tried, but the results were no more concordant, the deviations being finally traced to the imperfect removal of air. This was surmounted by removing the air by a vacuum, strongly compressing, breaking up again, placing a second time in a vacuum, and re-compressing. Under these experimental conditions all the natural and artificial graphites after complete purification gave the same density of 2.253 at 15° C. compared with water at 4° C.—The utilisation of turf for the purification of sewage: A. Muntz and E. Lainé. The experiments detailed show that natural turf is a highly satisfactory medium for forming sewage filter beds. The experimental filter has been at work for more than seven months, and its activity is still unimpaired. It is capable of treating a volume of from three to four cubic metres of sewage per square metre of surface per day. Figures are given of the chemical and bacterial purification effected, and fish live without inconvenience in the effluent. If loaded above this, the effluent is fair, but not so good, and it has been noted that on reducing the load to the normal figure the filter immediately recovers to original efficiency.—Observation of the transit of Mercury at the Observatory of Rio de Janeiro: M. Morizo. The atmospheric conditions were unfavourable to good observations.—Observation of the transit of Mercury of November 13-14, 1907, at Schoi, Italy: Fr. Faccin. The atmospheric conditions were bad.—The summability of Fourier's series: A. Buhl.—The choice of the exponent of convergence for integral functions of infinite order: A. Denjoy.—The measurements of general movements of the soil by means of levellings repeated at long intervals: Ch. Lallemand. An analysis of the degree of exactitude practically possible in levelling operations shows that it is only in exceptional cases that a repetition of the measurements will permit the demonstration with certainty of gradual general movements under 1 decimetre.—The statics of a deformable surface and the dynamics of a deformable line: Eugène and François Cosserat.—The transformations of solutions of white phosphorus into red phosphorus: Albert Colson. Experi-

ments with solutions of phosphorus in carbon bisulphide and in turpentine at various temperatures between 230° C. and 200° C. showed that the presence of the solvent causes the rate of transformation of the white into the yellow modification to be reduced.—The constitution of cast irons containing manganese: **L. Guillet**. Manganese displaces the eutectic point, which is produced for lower percentages of carbon than with the iron-carbon alloys. Other changes caused by the gradual increase of the percentage of manganese are noted.—Ammoniacal cuprous sulphate: **M. Bouzat**. The salt is formed by the interaction of aqueous ammonia, cuprous oxide and ammonium sulphate, and precipitated by alcohol. It is filtered off on asbestos, and washed with alcohol and ether. Great care has to be taken to exclude all traces of air, all reagents being freshly boiled, and the whole series of operations carried out in a current of pure hydrogen. Analyses of the precipitated salt show it to possess the composition $\text{Cu}_2\text{SO}_4 \cdot 4\text{NH}_3$. The reactions are those of a cuprous salt, oxidising instantly when exposed moist to the air, and giving copper, cupric sulphate, and ammonium sulphate when treated with dilute sulphuric acid.—Syntheses in the camphor group. The complete synthesis of β -campholene lactone: **G. Blanc**. The starting point of this synthesis is α -dimethylglutamic acid, and this is converted successively into its sodium derivative, dimethyl-cyclopentanone-acetic acid, and the ethyl ester of the latter. The tertiary glycol obtained from this by Grignard's reaction forms a lactone identical with β -campholene lactone.—The constitution of the α - and β -methylstearines and of isoparaffine: **Charles Mourou** and **Amand Valeur**.—The synthesis of racemic dihydrocamphoric acid: **L. Bouveault** and **R. Lacquin**.—The innervation of the sterno-mastoid and cleidomastoid muscles: **F. X. Lesbre** and **F. Maignon**.—The action of fresh kola nut on work: **J. Chevalier** and **M. Alquier**.—The apparent double refraction of vibratory cilia: **Fred Vies**.—The action of choline on the arterial pressure: **A. Desgrez** and **J. Chevalier**. Choline furnishes the first example of a physiological substance of well-defined chemical composition, producing a marked lowering of the arterial pressure. It behaves as an antagonist to adrenaline, and it is possible to associate these two substances in such quantities that the one neutralises the effect of the other on the blood pressure.—Hexamer sennarichins: **Edouard de Ribaucourt**.—*La graisse* in wine: **E. Kayser** and **E. Manceau**. The change in wine known technically as *la graisse* is complex, and is not caused by a single organism, but by the combined growth of several organisms.—The diminution of the salinity of sea water after filtering through sand: **J. Thoulet**. It is popularly supposed that the salinity of sea water is considerably reduced by filtration through sand. Direct experiments of the author have failed to confirm this.

DIARY OF SOCIETIES.

THURSDAY, JANUARY 23.
ROYAL SOCIETY, at 4.30.—Report on the Eruptions of the Soufrière in St. Vincent in 1902, and on a Visit to Montagne Pelée in Martinique. Part II.—The Changes in the Districts and the Subsequent History of the Volcanoes: **Dr. Tempest Anderson**.—Petrographical Notes on the Products of the Eruptions of May, 1902, at the Soufrière in St. Vincent: **Dr. J. S. Fleet**.—On the Intimate Structure of Crystals, Part VI, Titanic Oxide, its Polymorphs and Isomorphs: **Prof. W. J. Sollas, F.R.S.**—Dietetics in Tuberculosis: Principles and Economics: **Dr. N. D. Barde-well** and **J. E. Chapman**.—The Origin and Destiny of Cholesterol in the Animal Organism, Part I.: On the so-called Hippocoprosterol: **C. Dorée** and **J. A. Gardner**.
ROYAL INSTITUTION, at 3.—Recent Light on Ancient Physiographies: **Prof. W. W. Watts, F.R.S.**
INSTITUTE OF ELECTRICAL ENGINEERS, at 8.—Standard Performances of Electrical Machinery: **R. Goldschmidt**.
FRIDAY, JANUARY 24.
ROYAL INSTITUTION, at 9.—The Extinction of Malta Fever: **Col. David Bruce, C.B., F.R.S.**
PHYSICAL SOCIETY, at 5.—Recalculation Curves: **W. Rosenhain**.—An Experimental Examination of Gibbs' Theory of Surface Concentration Regarded as the Basis of Adsorption, and an Application to the Theory of Dyeing: **W. C. M. Lewis**.
INSTITUTE OF CIVIL ENGINEERS, at 8.—A Cost Theory of Reinforced-Concrete Beams: **J. R. Wade**.—The Neutral Axis in Reinforced-Concrete Beams: **E. I. Spiers**.
SATURDAY, JANUARY 25.
ROYAL INSTITUTION, at 3.—The Electrification of Railways: **Prof. Gabriel Kapp**.
MATHEMATICAL ASSOCIATION, at 2.30.—Address by the President, **Prof. G. H. Bryan, F.R.S.**—On the Teaching of Elementary Mechanics, with Special Reference to the Preparation and Use of Simple and Inexpensive

Apparatus: **W. J. Dobbs**.—On the Teaching of the Elements of Analysis: **C. O. Tuckey**.—On the Geometrical Treatment of Series in Trigonometry, with Lantern Illustrations: **F. J. W. Whipple**.—On a New Treatment of Similarity in Elementary Geometry: **W. E. Bryan**.—Machine for Drawing Rectangular Hyperbolas: **H. L. Trachtenberg**.
ESSEX CLUB (at the Essex Museum, Romford Road, Stratford), at 6.—Report of Club's Delegate at British Association, Leicester, 1907: **F. W. Rüdler**.—On Plant Distribution in the Neighbourhood of Felstead, Essex: **J. French**.

MONDAY, JANUARY 27.

SOCIETY OF ARTS, at 8.—The Theory and Practice of Clock Making: **H. H. Cunyngbame, C.E.**
ROYAL GEOGRAPHICAL SOCIETY, at 8.30.—Exploration and Climbing in the Gurhwal Himalayas: **Dr. T. G. Longstaff**.
INSTITUTE OF ACTUARIES, at 5.—On the Construction of Mortality Tables from Census Returns and Records of Deaths: **G. King**.
TRUSTEES' MEETING, at 7.30.—**Roman Britain**: (a) Its Frontiers and Garrison: **Prof. F. J. Haverfield**.
ROYAL ANTHROPOLOGICAL INSTITUTE, at 8.30.—Annual General Meeting. President's Address: Anthropology in the Eighteenth Century: **Prof. D. J. Cunningham, F.R.S.**
INSTITUTE OF CIVIL ENGINEERS, at 8.—Continued discussion: Experimental Investigations of the Stresses in Masonry Dams subjected to Water Pressure: **Sir J. W. Outley, K.C.I.E.**, and **Dr. A. W. Brightmore**.—Stresses in Dams: an Experimental Investigation by Means of India-rubber Models: **J. S. Wilson** and **W. Gore**.—Stresses in Masonry Dams: **E. P. Hill**.

WEDNESDAY, JANUARY 29.

SOCIETY OF DYERS AND COLOURISTS, at 8. Colloidal Dyestuffs: **Dr. E. Feilmann**.—Notes on the Dyeing of Cellulose: **Dr. J. N. Goldsmith**.
BRITISH ASTRONOMICAL ASSOCIATION, at 5.

THURSDAY, JANUARY 30.

ROYAL SOCIETY, at 4.30.—*Probable Papers*: On the Observation of Sun and Stars made in some British Stone Circles. Third Note: The Aberdeenshire Circles: **Sir Norman Lockyer, K.C.B., F.R.S.**—On the Non-periodic or Residual Motion of Water moving in Stationary Waves: **Mrs. W. E. Ayrton**.—The Refractive Index and the Dispersion of Light in Argon and Helium: **W. Burton**.—On the Generation of a Luminous Glow in an Exhausted Receiver moving near an Electrostatic Field, and the Action of a Magnetic Field on the Glow so produced: **Rev. F. J. Jervis-Smith, F.R.S.**

FRIDAY, JANUARY 31.

ROYAL INSTITUTION, at 9.—Recent Researches on Radio-activity: **Prof. E. Rutherford, F.R.S.**

CONTENTS.

	PAGE
Manx Archaeology	265
Chemical and Physical Tables . By T. H. L.	267
A New Text-book of Psychology . By W. B.	267
Our Book Shelf :—	
Vogl: "Die Physik Roger Bacos"	268
Kanthack: "The Preservation of Infant Life. A Guide for Health Visitors"	268
Richards: "Sanitation in Daily Life"	268
Tischbrock: "Der neue Leitfaden"	268
Letters to the Editor :—	
The Stresses in Masonry Dams.— H. M. Martin ; Sir Oliver Lodge, F.R.S. ; Prof. Karl Pearson, F.R.S.	269
The Nature of γ and X-Rays.— Prof. W. H. Bragg	270
Drifted Ice-crystals. (<i>Illustrated</i>).— Dr. Walter Leaf	271
The Interpretation of Mendelian Phenomena.— H. H. O'Farrell	271
Musical Sands.— Cecil Carus-Wilson	271
Filtration of Rain Water.— Enquirer	272
The Highland Overthrusts . (<i>Illustrated</i>). By Prof. J. W. Gregory, F.R.S.	272
The Total Solar Eclipse of January 3, 1908 . By Dr. William J. S. Lockyer	274
The British Science Guild	274
J. Macfarlane Gray	277
Notes	277
Our Astronomical Column :—	
Observation of Encke's Comet on December 25, 1907	281
A newly discovered Bright Minor Planet (1908 B.M.)	281
Measures of Double Stars	281
Ephemeris for Comet 1907f	281
The Absorption of D_3 (Helium) in the Neighbourhood of Sun-spots	281
The Orbit of the Spectroscopic Binary θ Aquilæ	281
Eclipse Observations, August, 1905	281
Science at Recent Educational Conferences . By G. F. Daniell	281
The Interdependence of Medicine and other Sciences . By Prof. W. H. Welch	283
Rainfall and Water-Supply . By Dr. H. R. Mill	286
University and Educational Intelligence	286
Societies and Academies	287
Diary of Societies	288

THURSDAY, JANUARY 30, 1908.

THE FUNCTION OF THE STAPES.

On the Impulses of Compound Sound Waves and their Mechanical Transmission through the Ear. By Sir Thomas Wrightson, Bart. Pp. 40, and portfolio of diagrams. (London: Thomas Kell and Son, 1907.)

LITTLE has been added to our knowledge of the auditory ossicles since the classical researches of Helmholtz, although the subject is of much interest. Sir Thomas Wrightson shows that, owing to the peculiar arrangement of the footplate of the stapes and the formation of the annular membrane, to and fro movements of the stapes are accompanied by vigorous transverse vibrations of its frame. These movements will be represented in any compound wave form by the points at which "the compound curve cuts across the average line representing the central or normal position of the membrane."

With the help of a very ingenious model, evidence is adduced that this complex of motions affords a reasonable basis for the analysis of compound notes, which is usually attributed to the fibres of the basilar membrane. Careful examination of the numerous wave forms reproduced by the author will, we think, make it clear that the theory advocated is worthy of attention. Sir Thomas Wrightson's criticism of the theory associated with the name of Helmholtz is not, however, entirely just. The statement that "In fact there is no intelligible explanation furnished by Helmholtz's theory why we can hear each note of a combination when all the component notes are sounded together" can be made with respect to any theory whatever. The real value of the hypothesis of Helmholtz is that it describes, not explains, a large series of phenomena which cannot easily be reconciled with rival theories. It remains to be seen whether Sir Thomas Wrightson's theory will better describe the facts. For example, the peculiar condition described by Jacobson under the name *Diplacusis binauralis dysharmonica*, in which the same note heard by the two ears simultaneously produces a dissonance, is most easily described by a theory of resonators in the cochlea. Again, if it be true that ossification of the fenestra ovalis is consistent with a partial preservation of hearing, as asserted by K. Schaefer (apparently on the authority of Frutiger), the function of the stapes would seem to be relatively unimportant; but evidence on this point is conflicting. The author assumes that an impulse is always imparted to the membrana basilaris by friction of the perilymph on its under surface; this is not necessarily the case. As Schaefer remarks:—

"It is conceivable that the fluid of the labyrinth, receding before the pressure of the stapes, flows from the Scala Vestibuli through the Helicotreme into the Scala Tympani, and conversely when rarefaction

occurs in the auditory passage. But there is no time for this during the rapid sound vibrations, and it is far more probable that the membranous partition of the Cochlea bulges towards the Scala Tympani when the stapes moves inwards."

Whatever position may ultimately be assigned to the theory of stapelial analysis, Sir Thomas Wrightson and Dr. Arthur Keith, who is responsible for the anatomical part of the work, are to be congratulated on the performance of an interesting research which throws much light on the mode of action of a structure not readily accessible to the physiologist. M. G.

LIFE AND DEATH.

The Prolongation of Life. By Elie Metchnikoff. The English translation edited by P. Chalmers Mitchell. Pp. xx+343. (London: W. Heinemann, 1907.) Price 12s. 6d. net.

MOST people desire to live long, and hence Prof. Metchnikoff's book is sure to have many readers. He not only discusses the means by which life may be prolonged, but he also examines the question whether it is desirable to prolong it. About this he has no doubt; he is a confirmed optimist, and points triumphantly to celebrated men who have begun life as pessimists and have ended it as optimists. The chief of these is Goethe. Several chapters are devoted to the consideration of Faust, the sorrows of Werther, and Goethe's life. But this part of the book and that which treats of morality will probably appeal to fewer readers than the earlier part, for the subjects are so vast and so difficult that it is not easy to deal with them in the short space given to them by the author.

It is of interest to observe that Prof. Metchnikoff carries his optimism to the point of thinking that living has become easier from a moral point of view owing to the advances of science. For example, as science gets rid of or improves the treatment of plague and diphtheria, there will no longer be any need of the high moral courage of those who went freely among sufferers from these scourges in order that they might alleviate them. Life is already so difficult that this is a point of view we commend to the consideration of those who oppose scientific workers, and hinder them by vexatious restrictions.

"The Prolongation of Life" is a remarkable book in many ways. It and the "Nature of Man," of which it is an extension, treat of a subject about which little has been written. The whole range of literature is ransacked by the author, and the facts and opinions collected are discussed with an originality, a width of view, and knowledge that give the book an especial fascination and constantly arrest the attention.

Prof. Metchnikoff is of opinion that when old age approaches, the phagocytes, which have hitherto been man's friends, become his enemies, and hasten death by devouring the essential cells of the vital organs of the body, especially those of the nervous system.

These cells are rendered particularly vulnerable to phagocytes by the action of poisons manufactured by the bacteria of the large intestine, and Prof. Metchnikoff suggests that this 'might to a large extent be prevented by taking skimmed milk which has been boiled and rapidly cooled, and on which pure cultures of the Bulgarian bacillus have been sown. This produces a pleasant, sour, curdled milk containing about 10 grams of lactic acid per litre, the lactic acid of which prevents intestinal putrefaction.

The author is dependent mainly upon two kinds of evidence, experimental and numerical, and therefore his difficulties are chiefly two. Many experiments which might bear upon the prolongation of life must necessarily be observed for many years. For example, he devotes much space to the uselessness of the large intestine; so far as his facts go there is nothing to be said against them—indeed, from them and others we are probably justified in thinking poorly of the large intestine—but before we can certainly know much about this numbers of human beings who have been deprived of their large intestine will have to be observed for many years.

As the question is the prolongation of life, the numerical evidence as to how long certain animals and plants live is of the greatest importance, but the author has to depend largely upon hearsay. Very few of his statements are evidence in the technical sense of the word. We are more likely to be correct in our knowledge of very old human beings than very old animals, but even with regard to human beings the evidence of extreme old age—say over 100 years—often breaks down when carefully examined. Those in doubt on this point should read T. E. Young "On Centenarians." Sometimes the age is accepted because it is on the tombstone, but, as Johnson says, "In lapidary inscriptions a man is not upon oath." Prof. Metchnikoff is inclined to accept the commonly stated age of Parr, but there is no real evidence as to his age at death. Still, when we remember the extreme difficulty of getting suitable facts to support his views it must be admitted that the author has shown marvellous skill in the presentation of his case. No one can put down the book without feeling that it makes us think, will well repay careful critical reading, and induces gratitude to Dr. Chalmers Mitchell for his translation and excellent introduction.

PHILOSOPHICAL ESSAYS.

Proceedings of the Aristotelian Society. New Series, Vol. vii., 1906-7. Pp. iv+244. (London: Williams and Norgate, 1907.) Price 10s. 6d. net.

THIS volume contains the papers read before the society during the twenty-eighth session, 1906-7. The papers are eight in number, with titles and authors as follows:—(1) Nicholas de Ultricuria, a Mediaeval Hume, by Hastings Rashdall; (2) on the nature of truth, by the Hon. Bertrand Russell; (3) on causal explanation, by T. Percy Nunn; (4) logic and identity in difference, by Miss E. E. Constance Jones; (5) Humism and humanism, by F. C. S. Schiller; (6)

fact, idea, and emotion, by Shadworth H. Hodgson; (7) intuition, by A. T. Shearman; (8) philosophy and education, by Benjamin Dumville.

Both in the subjects chosen and in the standpoints adopted for their discussion, the series is quite representative of modern English philosophy. In the first paper, by the late president of the society, we find that element of historical appreciation, one might almost call it antiquarianism, without which English philosophy would be ref of half its distinctive charm. The second is virtually a criticism of Joachim's recent "Essay on Truth." The monistic theory championed in that book, viz. that "only the whole truth is wholly true," is shown to rest upon an assumed "axiom of internal relations," which may be formulated as follows:—"Every relation is erounded in the natures of the related terms." The arguments in its favour are shown to be fallacious, and the way is thus cleared for a return to the dualistic theory that facts are completely independent of our knowledge of them—that experiencing does *not* make a difference to the facts. Finally, two theories, each admitting the possibility of a plurality of truths, are mapped out as tenable, between which the author prefers not to decide. The third paper is a very thorough and lucid treatment of the methods of explanation adopted in the various sciences, and should be found useful by those interested in the more concrete side of epistemology. Miss Constance Jones's paper is good, but too technical in nature to receive further mention here. In his paper, Dr. Schiller devotes many pages to the orientation of the pragmatic philosophy, defending it especially against the charge of kinship with the empirical scepticism of Hume. Particularly good is his exposition of Hume's theory of "activity," a portion of Hume's system unduly slurred over by the historian of philosophy. To his own panegyric of voluntarism the best antidote is to be found in the following paper (No. 6), by Dr. Shadworth Hodgson. This paper is excellent. However untenable one may feel some of his conclusions to be, one cannot but admire the clearness of conception and the feeling for reality which Dr. Hodgson displays. The analysis is carried out under the influence of the fundamental antithesis of "real conditions" and "conditionates." It is attempted to show that consciousness is a conditionate of which the real conditioning is to be looked for in something which is not consciousness. "This 'something' is known to us as matter and motions of matter"; therefore, says Dr. Hodgson, it is not a thing-in-itself. His argument takes no account of the alternative possibility that the reality of which matter is the phenomenon is itself mental, and that the efficiency of matter is really mental efficiency.

Mr. Shearman's paper is an attempt to map out the position of intuition in philosophy, and is extremely suggestive. In the last paper of the series we meet the well-needed reminder that philosophy is still indispensable in any theory of education. Philosophy alone is fitted to preside over the ideals which all educational systems must recognise.

W. B.

PRIMITIVE INTERPRETATIONS.

- (1) *Ancient Egypt the Light of the World: a Work of Reclamation and Restitution*. In twelve books. By Gerald Massey. Two vols. Vol. i., pp. vi+544; vol. ii., pp. iv+545-944. (London: T. Fisher Unwin, 1907.)
- (2) *Primitive Traditional History: the Primitive History and Chronology of India, South-Eastern and South-Western Asia, Egypt, and Europe, and the Colonies thence sent forth*. By J. F. Hewitt. Two vols. Vol. i., pp. xxviii+448; vol. ii., pp. viii+449-1024. (London: James Parker and Co., 1907.)

(1) ONE of the recreations of an archæologist is the reading of the various remarkable works that are produced by persons of untrained mind who know a little of the subject on which they write and are possessed of violent prejudices either for or against some particular form of religion. The latter element adds spice to the recipe. The peculiar nature of the late Mr. Massey's preface to his present "work of reclamation and restitution in twelve books," as he called it, disarms the critic, however, to some extent. He does not know what he ought to say in the circumstances. Mr. Massey had in the course of a long life read much and noted much. Unluckily he had not read deeply enough. He never attempted to get his own knowledge, but depended on what others said. Hence in any case his book would be of no value except as a compilation. But, further, he had little idea of what is and what is not permissible in logical argument; very few of his syllogisms are without a flaw; he had no perception of what is possible or impossible in respect of philological comparisons, and he was dominated by a fanatical belief with regard to the origin of Christianity which at once takes his book out of the realm of science.

It is no use collecting anthropological data if all that one wishes to do with it is to prove that Christ and the evangelists and disciples were ancient Egyptian gods, whose names are twisted to suit the argument. For Mr. Massey, Jesus Christ is the deified scribe Imouthes or Iemhetep (why, we are not told), Thomas is the god Tum, Matthew is Maati ("The two Truths"), while for John he makes out an Egyptian equivalent called Aan. "The Ritual," he says (p. 905),

"preserves the sayings of the Egyptian Jesus who was Iu the Su, or Sa of Atum-Rei [? meaning] and Iusaäs [she was a goddess!] at Ou, and who was otherwise known as the Lord in different Egyptian religions. . . . This is the original *Evangelium Veritas* [sic: Mr. Massey's Latin was usually uninflected: cf. *ius prima noctis*]: the Gospel according to Mati=Matthew; to Aan=John; or Tum=Thomas," and so forth.

On p. 41 Mr. Massey says,

"In that [i.e. the Egyptian language] we find the word Ba signifies to be, Ba therefore is a form of to be. Also it is the name for the Ram and the Goat, both of whom are types of the Ba-er or Be-ing, both of whom say 'Ba.' The Cow says Moo. Mu (e.g.) means the mother, and the mythical mother was represented as a moo-cow."

Mr. Massey does not tell us the fact, which rather upsets his theory, that the Egyptians did not call a cow *mu*, but *ahu*. Apart from this, his statement that in Egyptian *ba* means "to be" is contrary to fact; in Egyptian "to be" is *un* or *iu*, and "to become" is *khēper*; there is no such word as *ba* meaning "to be." The word for mother was *m-t*: what the vowel was we do not know, probably *au* (*maut*). Mr. Massey goes on to say,

"The Ibis was one of the self-namers with its cry of 'Aah-Aah,' consequently Aah-aah is one name of the bird in the Egyptian hieroglyphics, and also of the moon which the Ibis represented."

Mr. Massey did not know that, though the word for "moon" (*not* for "ibis," which is *tekhen* or *hib*) is written conventionally *aah*, it was probably pronounced something like "ioh." Do ibises say "ioh-ioh"?

These are simple misconceptions as to matters of fact, and they give us reason to doubt whether Mr. Massey has any right to speak patronisingly of the work of an anthropologist like Mr. Frazer, as he does on p. 672:—

"Here we may say in passing, that the *Golden Bough* contains a learned, large, and serviceable collection of data, but the theories of interpretation derived from the writings of Mannhardt are futile. Besides which, mythology is not to be fathomed in or by a folk-tale, and the *Golden Bough* is but a twig of the great tree of mythology and sign language—a twig without its root. The reception of the work in England served to show how prevalent and profound is the current ignorance of the subject-matter. It was hailed as if it had plumbed the depths instead of merely extending the superficialities."

The last remark may be rather a point, but we can assure the Gallio, who may say, "How these anthropologists love one another," that Mr. Massey was no anthropologist, but a somewhat peculiar kind of mystic, and had no right whatever to criticise Mr. Frazer.

(2) Mr. Hewitt has unaccountably omitted China, Mexico, Peru, and Australia from his title. His work is comprehensive: it covers the whole world. And what it is all about it is difficult to discover. "History" it is not; there is no history known to science in it. But doubtless there is much known to Mr. Hewitt, and his Indian confidants, alone. The fact that Mr. Hewitt regards avatars of the Buddha "about 10,700 B.C.," and from "about 6700 to 4500 B.C.," as historical personages (p. 45) is enough to stamp him as a peculiar "historian."—His book is an *omnium-gatherum* of primitive traditions truly, and from them Mr. Hewitt, the believer in the historical character of avatars of Buddha, essays to disinter the early history of the human race by the help of an astronomical key. The astronomy we leave to the astronomers; of the "history" the following excerpt may suffice as a specimen:—

"The worship of the left thigh was succeeded by the worship of the right thigh of the independent sun-god, who took his own path sun-wise through the heavens, in whose ritual the right thigh of the sacrifice was given as their perquisite to the Jewish priests of the house of Kohath, the wearers of the

inspiring Ephod, and sons of the almond-tree. This age is historically most remarkable as that of the great moral upheaval which gave birth to the wide-spread movement towards individual regeneration, and the attainment of sanctity in mind and deed, which characterised the history of the Buddha, born as the divine physician Osadha-Dhāraka, the medicine-child in the age of the Yama Devaloko, the twin-stars Gemini, when the sun entered the Ashvin constellation Gemini in January-February, about 10,700 B.C., and which continued through the next succeeding periods of his Vessantara birth in the Tusita heaven of wealth. . . . This age was, as I show, contemporaneous with that characterised in Persian and Zend history as the introduction of the religion of Zarathustra . . . during this period a wide-spread régime of active trade, under the guidance of affiliated managers in touch with the Indian trade-guilds, was extended round the world from India as the centre, to the west of Europe under the Phœnicians, and to America. During this time of universal peace the world was governed by traders and was undisturbed by tribal wars. . . ." (pp. 45, 46).

This sort of "history" is worthy of a Mahatma. We have heard it from Indian and "theosophical" lips before, and we do not believe a word of it. This age of universal peace about 10,700 B.C. "under the guidance of affiliated managers in touch with the Indian trade-guilds" is as unknown to scientific historians as Mr. Ignatius Donnelly's story of "Atlantis." It will be news to them, also, to hear that Zoroaster lived about 10,700 B.C.!

OUR BOOK SHELF.

Cyclopedia of American Agriculture. Edited by L. H. Bailey. Vol. ii., Crops. Pp. xvi+690. (New York: The Macmillan Co.; London: Macmillan and Co., Ltd., 1907.) Price 21s. net.

The second volume of Dr. Bailey's "Cyclopedia" deals with the field crops of North America, and opens with some interesting chapters on the economic side of plant life in general—the control of diseases, the principles of plant breeding and introduction, seeding, and the management and preservation of the crop. Though the plants dealt with in the main section of the book include the staple farm crops of this country, one cannot but be struck with the enormous diversity of the production of the United States. Its agriculture started practically on the basis of our own, with crops characteristic of temperate and humid climates, cotton being the only early addition on a large scale; but as population spread south and west, all the products of the Mediterranean region became included, and latterly the addition of the Sandwich Islands, Cuba, and Porto Rico to its territory has brought tropical and subtropical plants into the United States list. The valuable work done by the plant introduction division of the United States Department of Agriculture finds ample recognition here; the navel orange, Egyptian strains of cotton, with the date palm, the olive, and durum wheat for the arid regions, are striking examples of successful acclimatisation, and elaborate attempts are now being made to introduce tea.

The account of any individual crop is perhaps hardly full enough to be of much value to the farmer who is already engaged in that particular industry, and American conditions of climate and labour render much of the information inapplicable to British agriculture; but this volume of the "Cyclopedia" would be of the greatest service to any settler breaking ground in

a new country, and looking round for profitable crops outside the accepted routine. As in all cyclopedias, many of the illustrations are rather trivial and pointless, but the full-page reproductions from photographs are of real value and often of beauty.

Penrose's Pictorial Annual, 1907-8. Vol. xiii. Edited by William Gamble. Pp. xvi+184. (London: A. W. Penrose and Co., Ltd., n.d.) Price 5s. net.

This annual has now reached its thirteenth volume, and although its predecessors have attained a very high order of excellence as regards text, illustration, and style, the present issue eclipses them all.

The volume before us is of perhaps more than usual interest, because a fundamental and important change has been made throughout the whole book. The editor, in his excellent and interesting summary of the year's work, tells us that on previous occasions the chief difficulty which became apparent in preparing these volumes was to present something conspicuously new in process work. The difficulty arose through the wonderful standard of excellence which had already been reached in photo-mechanical processes.

Owing to certain criticisms which indicated that the best effects from half-tones and three-colour blocks could only be obtained on highly-glazed paper, and with brilliant inks, and this did not comply with the canons of good art, an attempt has been made in the present volume to meet these views. The paper-maker has been asked to make a paper which should have a perfect surface without the gloss, and the ink-maker has been requested to prepare inks that would be suitable to the new kind of paper. To give the text illustrations a better chance, screens with 133 instead of 150 lines to the inch have been employed. The result of this combined effort, which is presented in these pages, is distinctly good, and throws great credit on all concerned in the endeavour. As in former years, the volume teems with a great number of excellent illustrations by various processes, and the text contains a wealth of information on allied topics.

The frontispiece is a fine heliotype reproduction from an old copper engraving, and the general appearance of the book leaves nothing to be desired.

The book should be found more useful than ever to anyone who wishes to seek the best process for book or catalogue reproduction, no matter whether the illustrations have to deal with the reproductions of oil paintings, photographs, black-and-white drawings, or such subjects as machinery, woodwork, or china.

The Education of To-morrow. By John Stewart Remington. Pp. 115. (London: Guilbert Pitman, 1907.) Price 2s. net.

"It is my honest belief," says Mr. Remington towards the end of his book, "that at the bottom of almost all British failure in business or in industry is the nightmareish, unpractical nature of British education." Though he does not appear to be familiar enough with the progress which has been made during the last ten years in devising and introducing practical methods into our schools, Mr. Remington has much to say that deserves the earnest attention of schoolmasters and educational authorities generally. "The education of to-morrow will be an education for practical men, every branch of which will have to justify itself by ultimate usefulness." He combats successfully the common criticism that this would be to make education merely utilitarian and to ignore the need for culture. To foster in public schoolboys the belief that "the best people" cannot go in for trade, he describes as "suicidal." Altogether the little book provides much material for

thought, and it may be commended to all who desire the welfare of their country. We hope, however, the education of the future will teach that it is unpardonable for a book of this kind to be published without an index.

Scouting for Boys. A Handbook for Instruction in Good Citizenship. By Lieut.-General R. S. S. Baden-Powell, C.B. Parts i. and ii. (London: Horace Cox, 1908.) Price of each part, 4d. net.

In an earlier volume, "Aids to Scouting," Lieut.-General Baden-Powell has shown that the characteristics of the good scout are those which distinguish the successful man of science. In his appeal to headmasters in 1901, Prof. Armstrong pointed out how full of good advice in the training of children that book is. The present book, which is to be completed in six parts, two of which have now appeared, also may be recommended as likely to result in the development of faculties of observation, regard for accuracy, conscientiousness, and other desirable characters.

Photograms of the Year 1907. Text, pp. 48; illustrations, pp. 112. (London: Dawbarn and Ward, Ltd., 1907.) Price 2s. net.

BETWEEN the covers of the book we have a collection of reproductions of about 200 different pictures, about one-fourth of which are selections from the exhibitions held recently in London, while the remainder serve as examples of the pictorial work of the year, not only by home, but by colonial and foreign workers. The pictures are excellently reproduced, on stout paper, and every care seems to have been taken to ensure their being as true as possible to the originals.

In the text Mr. H. Snowden Ward gives us an interesting critique of the "Work of the Year," and contributions are included from the pens of various well-known colonial and foreign photographers.

Those who wish to make themselves acquainted with the main features of last year's work in pictorial photography will find much to interest them in the present issue.

LETTERS TO THE EDITOR.

[The Editor does not hold himself responsible for opinions expressed by his correspondents. Neither can he undertake to return, or to correspond with the writers of, rejected manuscripts intended for this or any other part of NATURE. No notice is taken of anonymous communications.]

Stability in Flight.

Now that two or three people have succeeded, by skilful manipulation, in travelling on a more or less determinate course in the air, it would be well that inventors should turn their thoughts to securing stability in flight without the demand of constant attention on the part of the aeronaut.

In a note written some years ago on this subject, I said:—"No flying machine will be satisfactory which does not contain some automatic device for securing stability. The principles which must be embodied in such a governor are in themselves simple, and may be realised in many ways.

"The principal axes of the flying machine have to be kept related in a definite way to the direction of the force of gravity and of the accelerations.

"To do this, the action of the governor must depend on the position of the axes of the machine in relation to the direction of two pendulums (or their equivalents), one having a very long and the other a very short period. In this connection, 'long' and 'short' have reference to what may be called the rate of instability." (A twenty-second period for the long, and a tenth of a second for the short pendulum, would be the sort of thing required.)

NO. 1996, VOL. 77]

The long pendulum presents the greatest practical difficulties, but they can be met.

Until something of this kind is done, flying will remain a feat of personal skill. Probably most people could acquire this skill if they could practise when young, but, in learning to fly, any accident generally puts an end to the power of gaining further experience.

A. MALLOCK.

6 Cresswell Gardens, Kensington, S.W.

The Inheritance of "Acquired" Characters.

MAY I have space for a communication dealing, not with Mr. Spicer's letter (p. 247), but with some problems it suggests?

An individual develops from the germ-cell under the influence of various stimuli, of which the principal are nutriment, use, and injury. Nutriment supplies the material, but *not* the stimulus, for *all* growth. Up to birth, the human being, for example, develops wholly or almost wholly under this stimulus. Subsequently some of his structures continue to develop under it, for instance, his hair, teeth, external ears, and organs of generation, which grow whether or not they be used. But most of his structures now develop mainly, if not solely, under the stimulus of use, for example, his voluntary muscles, limbs, heart, and brain. Thus if the limb of an infant be paralysed it grows comparatively little, and the muscles atrophy. If the individual be injured, as by a cut, the injury supplies the stimulus for the growth (scar) which repairs the damage.

Scientific writers are accustomed to divide the characters of a living being into those which are "inborn" or "innate" and those which are "acquired," and are in the habit of declaring that the former tend to be "inherited" by offspring, but not the latter. I doubt if anything in science has been provocative of more confusion, misunderstanding, and futile controversy than this use of inaccurate terms. All our evidence indicates that the structures of the child are derived, not from the corresponding structures of the parent, but wholly from a germ-cell which dwelt as a parasite within the parent. Only in a purely metaphorical sense, then, does the child inherit from the parent. It resembles the parent merely because parent and child are derived from very similar germ-plasms which have been acted on to a very similar extent by very similar stimuli.

If we analyse the words of biologists carefully, we find that by an inborn character they imply one which has developed under the stimulus of nutriment, and by an acquired one which has developed under the stimulus of use or injury. When they speak of the "transmission" of an "inborn" character, they imply that it has developed in both parent and child under the stimulus of nutriment; when they speak, as is still sometimes done, of the transmission of an acquired, they imply that a character which developed in the parent under the stimulus of use or injury has developed in the child under the stimulus of nutriment. Apart from the immediate effects of injury (e.g. loss of tissue), I think it would puzzle anyone to indicate in what respects an "inborn" character is more innate and inherited than an acquired. Obviously these vitally useful powers of growing, of developing in certain fixed directions under the stimulus of use and injury are just as truly inborn and rooted in the germ-plasm, just as truly products of evolution, as the power of growing under the stimulus of nutriment. It follows that the so-called acquisitions are "innate" and "inherited" in precisely the same sense as the so-called inborn characters.

It is true that, since no character can be used or injured until it exists, all structures begin to develop under the stimulus of nutriment, and therefore that all acquisitions are modifications of innate characters. But early development is no evidence of innateness, and most acquisitions, like most of the growth made under the stimulus of nutriment, are nothing other than extensions of growth previously made. It is true also that innate characters arise inevitably as the child develops, whereas some acquisitions are more or less rare. But this is only because the stimulus of nutriment is inevitably received,

whereas the stimulus of a particular use or injury may not be received. If, however, the latter be received, the acquirement arises just as inevitably as the innate character. Thus if the child receives a like injury, it reproduces the scar on its parent's nose as certainly as the nose itself. If the nose is inborn and inherited, then the scar is inborn and inherited in the same sense.

Had the true nature of the distinction between innate and acquired characters been realised, had it been realised that the difference is one of stimuli, not of innateness or inheritability, and that acquirements are just as much products of evolution as innate characters, it is impossible that the controversy as to the alleged "transmission" of the former could have endured so long as it did. In effect, it was maintained by Lamarckians that a character (e.g. a scar) which the parent was able to acquire in a certain way (as a reaction to injury) because a long course of evolution had rendered such acquisition possible to the members of his race is reproduced by the child in a different category of characters, and in a way (as a reaction to nutriment) that no member of his race had ever acquired it before, and with which, therefore, evolution had nothing to do. An actual miracle was supposed to happen, the miraculous nature of which was concealed under a misuse of terms.

At the present day the majority of biologists are apt to regard "acquirements" as mere accidents, as things inferior to and less worthy consideration than "inborn" traits. Very little study has been given to the evolution of the power of making acquirements, especially use-acquirements, and hardly any attempt has been made to ascertain in what proportions the "normal" individual of any species is compounded respectively of innate and acquired traits. Lloyd Morgan, Baldwin, and Osborn have certainly dealt with this power under the name of "plasticity." But plasticity is not the same as growth, as development, and the fact that they have regarded acquirements as useful to the species mainly as affording time and opportunity for the evolution of corresponding inborn traits indicates an adherence, even if only a modified adherence, to the prevailing biological view. The evidence seems clear that animals low in the scale of life have little or no power of making use-acquirements, but that this power increases as species are more highly placed until in man the main difference between the infant and the adult is due to the use-acquirements made by the latter during development. The power of making use-acquirements is present only in structures where it is useful, and only to an extent that is useful. Great adaptability is thus conferred on the individual, for he develops only those traits which are useful to him in his particular environment, and is burdened with no others. We have a special name, memory, for the power of making mental use-acquirements. Memory is nothing other than the power or faculty of storing mental experiences, and so adding to the mental growth. It is strictly analogous to the faculty of storing physical experiences, and so adding to the physical growth. Without memory there could be feeling and (instinctive) emotion, but no thought, for the materials of thought would be lacking. Animals low in the scale of life appear to have little or no memory; they are guided more or less entirely by instinct. Man is intelligent and adaptable because he has a memory. He is the most intelligent of animals because he has the largest faculty for storing experiences. Memory, the power of learning, develops under the stimulus of nutriment, but intelligence and reason develop under the stimulus of use. They are amongst the contents of memory. We learn to think and reason just as surely as we learn the facts about which we think and reason. Reason, therefore, is an "acquirement."

Probably no problem in biology is of greater theoretical interest than that of the evolution of the power of making use-acquirements. Certainly no problem is of nearly such practical importance as that of determining the extent to which the individual develops, on the one hand, under the stimulus of nutrition, and, on the other, under the stimulus of use. From the times of Lamarck, Spencer, and Romanes, biologists have very generally assumed that use tends to cause development in all the structures of all animals, but that the amount of this modification is trivial.

As a fact, use causes development in only some structures in some animals, and the major part of the development of the human being is due to it. If, for example, biologists had ascertained and were agreed as to the amount of this development, we should know to what extent races and generations of men differ "innately" and to what extent by acquirement, and therefore what effect could be produced by this or that system of mental training. Educationists could then apply this knowledge to the training of the young. At present the basis of bed-rock fact is lacking, and biology is shorn of much of the practical importance which is its right.

I venture to write this letter in the hope of directing attention to one, at least, of the great problems of biology which are neglected under present fashions. Experiment itself, for example, loses much of its value unless the worker has clear and comprehensive notions concerning the subject with which he deals.

G. ARCHDALL REID.

The Melanic Variety of the "Peppered Moth."

MR. SPICER asks (January 16, p. 247), among other questions, "how does the 'peppered moth' contrive to appear in the black country hatched with sooty wings that harmonise with the now smoke-stained bark whereon he must rest?" His point, I conceive, is that the melanic variety is due in some unexplained way to the inheritance of acquired characters.

If Mr. Spicer found that an actor whom he had seen perform the part of Hamlet on Tuesday was cast for Macbeth on the Wednesday, he would not necessarily, I suppose, conclude that the actor had added the part of Macbeth to his repertoire during the intervening time. Now there is more than a possibility that the black coloration of the variety *Doubledayaria* may in like manner be a repertoire pattern of the "peppered moth" evolved in the remote ages of the history of the species. The dark form is not necessarily atavistic in the general acceptance of the term, as it may only have been developed by some stocks of the species in a more or less restricted portion of its range, the stocks in question having reverted when the factor that put a premium on blackness gave place to the original conditions of their habitat. The facts of mimicry prove that the germ plasm of the Lepidoptera can carry more than one distinctive pattern, and the temperate experiments of Standfuss and Merrifield suggest that such latency may extend over long periods of the insect's history.

Mr. Spicer has tacitly assumed that the variety is confined to the black country, but this is by no means the case. The dark form is, I believe, taken in the Black Forest in Germany; certainly it occurs in Denmark, and records from our own southern counties are not wanting. It is by no means uncommon in and round London, and has been taken as far out as Brentwood and Bexley, both of which are outside the smoke limit as regards soot-stained bark. In the last-named district, my friend Mr. Newman has taken melanic forms of several other *Geometrid* moths in addition to var. *Doubledayaria*.

There seems to be no doubt as to the increase of melanism among the tree-resting species of Lepidoptera in certain districts of England during the past fifty years, but this increase is apparent outside the actual smoke-stained area, though not perhaps beyond the range of darker bark owing to the destruction of the lichens—a cause that may have operated locally on more than one occasion during the life-history of the species quite irrespective of a sooty civilisation.

Apart from lichens, even a change in the species of trees composing a forest might have a marked effect on the cryptic coloration of the bark-resting species of moths in the locality. Birch would favour a pale coloration; oak, cherry, and especially the thorns, a darker one; beech, with its dense shade and wide range of bark coloration, a darker or lighter pattern, according to the dampness of the situation and whether the particular species emerged before or after its full leafage was attained.

The time during which the dark form could have been evolved from the normal coloration of the species by the action, direct or otherwise, of smoke is less than a

century, say from fifty to seventy-five generations—presumably a quite inadequate period for the evolution and fixing of the form by the selection of small chance variations. Certainly, if the analogy of language in the human race is permissible, the number of generations is far short of what would be required to impress any character on the heredity of a species by the inheritance of acquired characters, even if we could find any reasonable connection between soot-stained bark and darkened wings for the purposes of the theory.

But gradual adaptation during the present epoch does not fit the facts for another reason. The darkening, if gradual, would have been noticed by entomologists, as is the case with *Alecta nebulosa* in Delamere Forest and *Hybernia leucophaearia* in Epping Forest. The species would be a beautiful example of a mutation if it were not for the fact that intermediates, though rare, have a puzzling habit of turning up; and, what is more serious, a careful examination of the melanic forms reveals the fact that on the upper margin of the hind wings, where they are covered by the fore wings when the moth assumes its normal resting position, there is an area of the original pale coloration. As in the reverse case of the exposed tip of the underside of the fore wings of many butterflies being coloured quite differently from the rest of the wing area, in order that it may match the cryptic pattern on the underside of the hind wings, the retention of the pale area in var. *Doubledayaria* can only be accounted for by the supposition that the variability is the work of natural selection.

If the above reasoning be correct, the black variety must either be regarded as the recurrence of a pattern slowly evolved in some previous epoch, or we must consider it as an example of the working of Weismann's germinal selection. The needs of cryptic adjustment to environment having put a premium upon darker, but not necessarily black forms, the determinants of selection within the characters tend by the operation of selection within the germ to increase progressively to a point where they are cut off by the operation of natural selection upon the individual. As a consequence, a few rare examples will always be thrown having such a progressive character in excess, and should any rare and sudden chance such as is afforded to melanism by our smoky civilisation occur, an enormous premium is placed upon the survival of their offspring.

154 Lower Clapton Road, London, N.E. A. BACOT.

Inductance in Parallel Wires.

A PROBLEM of some considerable importance to the practical engineer or physicist is that of calculating the effective self-induction of a circuit consisting of two parallel wires, the one being the return of the other. When the wires are not very close together, and their current is either steady or only very slowly alternating, satisfactory results are known to be given by the formula

$$L = 2 \log \frac{c}{ab} + \frac{1}{2}(\mu_1 + \mu_2),$$

where L is the self-induction of a length l, c the distance between the wires, which have radii a, b, and μ_1, μ_2 the permeabilities of their materials. But if the current oscillates rapidly, this formula fails to give even approximately correct results. Now in many practical problems, such, for example, as the measurement of small inductances not greater than 1000 microhenries, it is necessary to employ long leads to keep them at some considerable distance from bridge and other circuits. A knowledge of the self-induction of such leads is very desirable. Some results which I have recently obtained are capable of finding this quantity in most useful cases, and it may prove of use to give a short statement of them, pending more detailed publication.

The self-induction has a simple expression only if the two wires be equal in radius. In this case it takes the form

$$\frac{L}{l} = 4 \log \frac{c}{a} + \frac{4\mu}{x} \cdot \frac{\text{ber } x \text{ her}' x - \text{bei } x \text{ hei}' x}{(\text{her}' x)^2 + (\text{bei } x)^2},$$

NO. 1996, VOL. 77]

where $\text{ber } x, \text{bei } x$ are the functions introduced by Lord Kelvin, and subsequently tabulated (*vide* Presidential Address to the Institution of Electrical Engineers, 1889).

If $\frac{M}{2\pi}$ be the frequency of alternation per second, σ the specific resistance of a wire, μ its permeability, then

$$x = 2a \sqrt{\frac{\pi \mu l}{\sigma}}$$

This formula, passing naturally into the former when the frequency is small, becomes less accurate as c decreases and as the frequency or radius of a wire increases. So far as the first cause is concerned, it is subject to an error of not more than 1 per cent. when $c=10a$, and 4 per cent. if $c=5a$. If $c=3a$, which is the limiting closeness for most practical purposes, the error is about 10 per cent., which is not usually too great. The other causes of error may be considered together.

The per cent. error they produce is of order $100 \cdot \frac{a^2}{V^2}$, where $V=3 \cdot 10^{11}$. Practically, a is never more than about 2 millimetres, and thus, with a frequency of a hundred million per second, the error is not more than one-tenth per cent. The range of application of the formula is therefore extremely wide. A formula equally accurate may be given when the wires are unequal, but it is somewhat cumbersome.

J. W. NICHOLSON.

Trinity College, Cambridge, January 21.

Stock Frost or Ground Ice.

DURING the recent frosty weather the subject of what is locally called "stock frost" has been much to the front in this neighbourhood. This phenomenon is known to the scientific world, I believe, as "ground ice," and the circumstances in which it appears and disappears present to the ordinary observer a very great many puzzling features.

I should be exceedingly glad if some of your readers would kindly give me, through the columns of NATURE, their opinion on several points which puzzle and interest me and others in connection with "stock" or ground ice.

(1) I wish to know, first of all, what are the essential conditions for the formation of ground ice on the bed of a river?

(2) Is it essential, or does it favour the formation of "ground" ice, that there should be no surface ice? We notice that when a very cold and very strong north-east wind is blowing, violently agitating the surface water, there is no surface ice, but a formation of ground ice at the bottom of the river.

(3) What are the circumstances to which is due the presence of ice-cold water at the bottom of a river, cold enough to be precipitated into ice?

This ice-cold water cannot reach the bottom of the river by gravitation, because its density is inferior to that of water at a higher level. To what, then, is due this cold temperature on the river bed?

(4) Can the bulk of water in the river bed be a conductor of cold from the surface to the bottom of the river in any other way than that of the mechanical action of running water? I assume that when ground ice appears in a river the whole of the water above it is of an ice-cold temperature, but it has not formed into ice because of the lack of the ice-precipitating conditions which exist on the bed of the river.

(5) Do the conditions necessary for the formation of ground ice operate more favourably in ice-cold still water or in that which is agitated, say, by passing through a mill? My own observation is that ground ice appears nearer to a mill on its upper side than on its lower side, and I want to know the reason of this.

There is quite a long list of questions which might be asked in connection with the formation of ground ice, but I fear that I have already trespassed too much upon your space.

JOHN J. HAMPSON.

Cotessey Vicarage, near Norwich, January 20.

THE PRODUCTION AND MANIPULATION OF INDIA-RUBBER.¹

IN this work the author gives a description of the various stages through which india-rubber passes from the time when it oozes out of the tree until it leaves the factory, a finished article, fashioned and fit for the service of man. The book is expressly designed for the general reader. It does not, except incidentally, deal with the chemistry of india-rubber, nor with the minute details of manufacture; the volume is neither a laboratory guide nor a factory handbook. There are, however, many people interested in india-rubber who are neither chemists nor manufacturers, and the author thinks that a volume conceived on broad general lines to expound the natural and commercial history of rubber cannot be deemed a superfluity. Similarly it may, perhaps, not be amiss to give here a short outline of the matter for the benefit of those readers of NATURE who, likewise, are neither chemists nor manufacturers.

Many species of plants are now known to yield marketable rubber. They range from the lofty *Hevea brasiliensis* of the Amazon swamps to the *Landolphia*

are also present resinous bodies, relatively small in amount, but important in their effect upon the quality of the rubber, that are not eliminated by washing. The cleaned rubber is "compounded" where necessary (*i.e.* having regard to the purpose it is destined to serve) by kneading it with various mineral ingredients, such as antimony sulphide, iron oxide, litharge, and barium sulphate, and is eventually vulcanised by treatment with sulphur before it emerges in its final form as motor-tyre, cable, or other article.

Mr. Terry writes on these subjects with the authority of personal knowledge, though perhaps without the lightness of touch desirable in a work of this character. Probably the second and fifth chapters of the book will be found of the most general interest. They treat respectively of "the production of raw rubber" and of "india-rubber plantations," giving as fully as the scope of the work allows a sketch of the present aspect of these matters.

Among points mentioned as calling for special attention, it is urged that more care should be given to the "tapping" operations, so that other juices in the trees shall not be allowed to mix with the rubber latex. Further, the exudations of other trees are sometimes mixed with the rubber latex for the purpose of increasing the bulk. The author mildly stigmatises this as an "injudicious" practice; it is surely a fraud. Another important point to which the attention of producers is directed is the desirability of removing or sterilising the fermentable albuminous substances present in the latex. They give rise to evil odours and become a nuisance, even if they do not injuriously affect the quality of the rubber itself—a point which is perhaps debatable.

As regards plantation rubber, an estimate of the area under cultivation about two years ago gave a total of some 150,000 acres, and this, no doubt, has now considerably increased. The chief regions concerned are Ceylon (40,000 acres), the Malay Peninsula (38,000), Africa (33,000), Mexico (10,000), and India (8000). Young plantations in a more or less experimental stage, covering in the aggregate some 20,000 acres, are also found in Borneo, Java, Brazil, Venezuela, Ecuador, Central America, and the West Indies. As to the quality of the plantation rubber, recent experiments seem to indicate that, judged by vulcanisation tests on a small scale, some plantation rubber at least is not inferior to the best "hard cure" Para. The author, however, remarks that up to the present there is a unanimous opinion amongst experts that plantation rubber is deficient in "strength" compared with the Brazilian forest product. Nevertheless, it commands a higher price, owing to its greater freedom from waste.

"Never before," say some recent writers, "have brokers or manufacturers had presented to them a raw rubber of the purity of the best plantation rubbers."

For this very reason, they urge, it may well be that the present rough practical tests applied to the raw rubber are insufficient for proper valuation. At present the question of the relative merits is an open one; we shall probably know much more about it during the next year or two, when larger quantities of the plantation product are expected to come into the market.



Smoking Para rubber with palm nuts by the method which has recently superseded the paddle to a great extent. From "India-Rubber and its Manufacture."

creepers of West Africa and the *Clitandra* shrubs, a foot or two high, the rhizomes of which yield the "root-rubber" of the Congo. The chief genera are *Hevea*, *Manihot*, and *Micrandra* (*Euphorbiaceae*); *Castilloa* and *Ficus* (*Artocarpacae*); *Hancornia*, *Funtumia*, and *Landolphia* (*Apocynaceae*); and *Callotropis* (*Asclepiadaceae*). The bark of the trees yields a milky latex, which is obtained generally by "tapping," though sometimes by the wasteful process of felling the tree. In various ways the latex can be caused to coagulate, much as ordinary milk is made to "curdle"; and the separated coagulum, after undergoing a process of "curing," is the "raw" rubber of commerce. This raw rubber, which comes here in various forms—leaves, biscuits, balls, cups, sheets, lumps, and slabs—contains water, sand, woody fibre, and other impurities, ranging in quantity from 15 to 50 per cent., which are removed by washing and rolling; and there

¹ "India-Rubber and its Manufacture," with Chapters on Gutta-Percha and Balata. By Hubert L. Terry. Pp. ix + 291. (London: A. Constable and Co., Ltd., 10 7.) Price 6s. net.

SCENERY AND NATURAL HISTORY OF NEW ZEALAND.¹

FEW countries enjoy so many natural advantages of scenery and climate as New Zealand, and none of similar extent can compete with this favoured land in the variety and interest of its indigenous fauna and flora. The scenery of the Southern Alps, with their snow-fields and glaciers, rivals that of Switzerland, and it may be doubted if the fjords of Norway can be compared in romantic beauty with the west coast sounds. The weird volcanic district of the North Island, with its hot lakes and geysers and the still smouldering fires of Tongariro and Ruapehu, stands in startling contrast to the peaceful forest-girt lakes of the south, with the snow-clad mountain peaks reflected in their clear waters. The luxuriance of the subtropical vegetation in the far north, with its kauri forest, tree ferns, and nikau palms, is only eclipsed by the still more luxuriant mixed forest of the wet west coast, with its gigantic evergreen beeches, conifers, and crimson-flowered ratas. The peculiar alpine and subalpine floras, again, with their beautiful *Celmisias*, their magnificent species of *Ranunculus*, their *Ourisias*, and, most interesting of all, the so-called "vegetable sheep" of the genera *Raoulia* and *Haastia*, are probably unsurpassed in botanical interest in any part of the world.

By far the greater number, at any rate of the flowering plants, are endemic, and even the outlying islands have many species absolutely peculiar to them. Some of the more striking plants, such as the cabbage tree (*Cordyline*, known to English horticulturists as *Dracæna*), the flax bush (*Phormium*, shown in the foreground of our illustration), *Olearia haastii* (one of the many beautiful species of this genus found in New Zealand), and some of the shrubby *Veronicas*, have already found their way into English gardens; but no one who has not been in the country can form any idea of the wealth and beauty of its native flora.

Associated with this striking vegetation is a no less unique and interesting indigenous fauna, in which the ancient tuatara and the numerous flightless birds of divers families—kiwis, kakapos, wekas, and Notornis—form the most conspicuous features, to say nothing of hosts of remarkable invertebrates, such as *Peripatus*, land planarians and nemertines.

It was inevitable that the process of settlement of the country by Europeans, with the consequent clearing of the forests and the introduction of carnivorous animals—dogs, cats, rats, weasels, and so on—should have a disastrous effect both upon the scenery and upon the plants and animals. Already much of the forest has been destroyed, and many of the unique native birds are almost extinct, especially those which have lost the power of flight, while the tuatara is no longer found on the mainland, having, it is said, been exterminated there by the pigs introduced by Captain

Cook, though still surviving on some of the small islands.

In these circumstances any attempt to arrest the progress of destruction must be heartily welcomed, and the New Zealand Government is to be congratulated upon the vigorous efforts which it is making in this direction. The report on scenery preservation recently issued by the Department of Lands is a most interesting document, with a wealth of beautiful photographic illustrations, one of the most striking of which we reproduce. We learn from this publication that already nearly three million acres have been set aside as national parks, and since the Land Act of 1892 came into force "the protection and preservation of the beautiful natural scenery with which New Zealand is so richly endowed has been steadily kept in view, and when any portion of Crown lands has been opened for settlement, areas of specially attractive forest, or land surrounding waterfalls, caves, or thermal springs, have been excluded from sale and set apart for all time by permanent reservation." In 1903 a special Scenery Preservation Act was passed, dealing with the acquisition and reservation of all

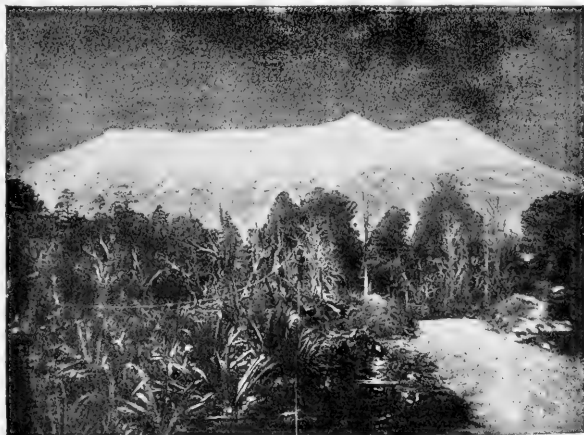

Along the Route of the North Island Main Trunk Railway: Ruapehu Mountains, from Raurimu. (Photo. C. Spencer.)

suitable lands, whether Crown, freehold, or native. A further Act provided for the formation of "The Scenery Preservation Board," which now acts as an advisory board to the Government, and reports on all cases of suggested reservations. That this board is no mere shadow but a really efficient instrument for the purpose in view is proved by the amounts which have been paid by way of compensation for land acquired during the three years of its existence. In 1904-5 the amount was only 216l. 4s. 10d., but in 1906-7 it had already risen to 7855l. 19s. 10d.!

No less important is the work which the Government has long had in hand in protecting the native animals and providing sanctuaries where they may remain unmolested, either by man or by the noxious animals which man has introduced. For this admirable purpose some of the small islands off the coast have been selected, such as Little Barrier Island in the north, Resolution Island in the south-west, and Kapiti Island in Cook Straits. These islands have been well chosen so as to give as great a range as

¹ (1) "Report on Scenery Preservation for the Year 1906-7." (Published by the New Zealand Government, 1907.)
(2) "Report on a Botanical Survey of Kapiti Island." By L. Cockayne. (Published by the New Zealand Government, 1907.)

possible in climatic conditions, nor has the purely scientific aspect of the question been neglected, for simultaneously with the document to which we have already referred, the New Zealand Government has just issued a detailed "Report on a Botanical Survey of Kapiti Island," by Dr. L. Cockayne, a botanist who is already widely known for his researches on the New Zealand flora. This exhaustive and painstaking piece of work deals with the physical geography and climate of the island, and with the introduced plants and animals, as well as with the indigenous flora. The latter is treated under the headings of the various plant-formations—classified as forest, shrub, coastal, meadow, and rock-formations—and much attention is devoted to ecological problems. The suitability of the island as a plant and animal sanctuary is discussed, and lists are given of the native and introduced plants. This report, again, is illustrated by numerous excellent photographs taken by the author.

The interesting monograph which we have thus briefly summarised is a good example of the activity and enthusiasm with which the representatives of natural science in New Zealand are carrying on the good work initiated by such pioneers as von Haast, Hutton, Hector, Kirk, Buller, and Parker, to mention only some among those who have already passed away from the scene of their labours.

ARTHUR DENDY.

LIEUT.-COL. R. L. J. ELLERY, C.M.G., F.R.S.

LIEUT.-COL. R. L. J. ELLERY, whose death we announced on January 16, was for many years the director of the Williamstown and Melbourne Observatories. To review his career is to recall the history of astronomy in Australia, so intimately was he connected with its progress. When he took up work as Government Astronomer in a rising colony, the instruments at his disposal were small, and the funds available for promoting astronomical research necessarily limited. The extension witnessed in the last forty years is due in no small measure to his initiative, and not the least of his services was to induce the colony to recognise the claims of science and to make more liberal provision for its needs. By his efforts arose the new observatory at Melbourne, and by his activity it became the centre for the prosecution of much useful work. There, too, at his instigation was mounted the four-foot reflector, at the time of its erection the most powerful instrument in the southern hemisphere. This instrument was much used for the examination of Herschel's nebulae, but in a new society, intent upon material progress, such a telescope was perhaps of even greater use by the interest it aroused in science generally. It served as a permanent reminder of the progress of science, and of the necessity of meeting its demands. For as the colonies enlarged, the claims of science required increasing support. In climatology, Col. Ellery's powers of organisation were invaluable. Not only did he collect the necessary information which indicated the more valuable localities for settlement, but gradually issued isobaric charts and storm warnings, at first applicable to the coast, but afterwards, as other colonies joined in an uniform scheme, published daily weather charts extending over the whole continent. Terrestrial magnetism was another subject he pursued with great eagerness, and geodesy, including pendulum experiments and longitude determinations, also claimed the attention of the staff. In a word, the observatory was the centre of enterprise and activity, encouraging the scientific spirit in many directions.

NO. 1996, VOL 77]

Forty years ago, the condition of meridian astronomy in the southern hemisphere was in a backward condition, and naturally much attention had to be paid to the determination of star places. Two standard star catalogues were issued from the Melbourne Observatory under Col. Ellery's direction, and, in addition to this special work, zone observations on a large scale were carried out. Taking part in the work of the International Star Chart has increased the meridian measures very considerably, since the observatory has loyally assisted others in providing the positions of guiding stars, where required, and for the final reduction of the measures on the photographic plates. Both in 1874 and 1882, Australia furnished a number of stations for the observation of the transit of Venus, and particularly on the former occasion the late director was instrumental in providing suitable equipment, and assisted the general programme very materially.

Col. Ellery retired from the office of director in 1895. Some portion of his leisure he devoted to the preparation of a history of the beginnings and growth of astronomy in Australia, and in various ways he was prominent in promoting scientific interests. He was elected a Fellow of the Royal Society in 1873, was a Fellow of the Royal Astronomical Society, and of many colonial societies for the promotion of scientific aims.

NOTES.

IN the Henry Sidgwick memorial lecture at Newnham College, Cambridge, on January 25, Mr. Balfour spoke on decadence, and remarked that progress is with the West and with the communities of the European type. "If our energy of development," he is reported to have said, "were some day exhausted, who can believe that there remains any external source from which it can be renewed? Where are the untried races competent to construct out of the ruined fragments of our civilisation a new and better habitation for the spirit of man?" He answered his own questions with the assertion that such nations do not exist. But Japan has been steadily assimilating what is most important in European civilisation for some years now, and her system of education is every year approaching in efficiency anything the West has to show. In the contingency of which Mr. Balfour spoke, it is easily conceivable that a people with a genius for development, such as Japan has shown, may take naturally the place of superiority and develop a system which is a distinct advance on any civilisation the world has yet known. Men of science will be pleased with Mr. Balfour's tribute, in the latter part of his lecture, to the achievements effected by science and to the extent science has assisted human development, but they will at the same time remember that the Government of which Mr. Balfour was the leader assisted scientific work no more than other Governments. Statesmen are eloquent in praising scientific work and methods, but few of them have sufficient courage of their expressed convictions to make adequate provision for the extension of natural knowledge which is the life-blood of the modern State.

WE regret to see the announcement of the death of Sir Thomas McCall Anderson, regius professor of medicine in the University of Glasgow since 1900.

MR. MORRIS K. JESUP, who died last week, bequeathed 200,000*l.* to the American Museum of Natural History for its collections. Mr. Jesup was president of the museum for twenty-five years; his name is familiar to anthropologists, and naturalists generally, as that of one who

gave generous assistance to various expeditions and other scientific enterprises.

LORD AVEBURY has been elected president of the Royal Microscopical Society, and will deliver an address on seeds, with especial reference to British plants, at the March meeting of the society.

We learn from the *British Medical Journal* that the Secretary of State for the Colonies has appointed Dr. W. J. Simpson, professor of hygiene at King's College, London, to proceed to the Gold Coast to assist in combating the present outbreak of bubonic plague at Accra. Prof. Simpson left for the Gold Coast on January 18.

To the *Times* of January 22 Miss L. L. Veley contributes a letter on the subject of luminous barn-owls, in which it is suggested that the emanation is due to the feathers of the birds having come in contact with luminiferous decaying wood in their roosting-places. This suggestion, which has doubtless occurred to many naturalists, affords a probable and satisfactory explanation of the phenomenon.

The Philosophical Society of Washington held its 643rd meeting at the Hubbard Memorial Hall, in the City of Washington, on January 18, the entire evening being devoted to commemorative addresses of the life and work of Lord Kelvin. Prof. A. G. Webster spoke of Kelvin's life and work, Prof. R. S. Woodward confined his address to Kelvin's contributions to geophysics, and Prof. Simon Newcomb devoted his remarks to Kelvin's character and personality, to which topic the British Ambassador also contributed some reminiscences. The president of the society, Dr. L. A. Bauer, presided.

DR. G. A. DORSEY, curator of anthropology in the Field Museum of Natural History, Chicago, has recently visited Cambridge before embarking on a protracted tour through the East Indian Archipelago, Australia, and Melanesia. After visiting the Philippines, where three of his students are engaged in ethnological researches, he will return to Chicago by way of China, Japan, and the Hawaiian Islands. He expects to be away from Chicago for about one year. This is merely a tour of inspection, but it may not unreasonably be expected that it will lead to future investigations by others in certain localities.

In the Rev. Dr. Lorimer Fison, who died near Melbourne on December 29, 1907, Australian anthropology has lost one of its earliest scientific workers. He was born in England on November 9, 1832, and went up to Caius College, Cambridge, but never took a degree; after residing some time in Australia he became a Wesleyan missionary and went to Fiji, and it was from him that Lewis Morgan drew important information for his "Systems of Consanguinity." Returning to Australia, Dr. Fison met Dr. A. W. Howitt, and a joint work on Australian marriage customs, &c., "Kamibaroi and Kurnai," appeared in 1880. Whatever his views at that date, Dr. Fison subsequently dissented from Morgan's interpretation of the facts in favour of primitive promiscuity, for in an address to the Australasian Association for the Advancement of Science he took the view that the group marriage did not mean more than marital right or qualification by birth. Dr. Fison, unfortunately, found little time for writing; papers by him on Fijian customs and kinship systems appeared in the *Journal of the Anthropological Institute*; he dealt with Fijian land tenure in the *Expository Times* of 1905, and a year earlier he published in "Tales of Old Fiji" a small part of his

great store of knowledge of that island. Some years ago he received a Civil List pension, but, to the loss of anthropology, broken health forbade him to do much literary work.

In the *Engineer* and in *Engineering* of January 24 a large amount of space is devoted to the Board of Trade inquiry into the facts relating to a disastrous explosion of a thermal storage-drum in connection with a Babcock and Wilcox boiler at Greenwich. The explosion took place on December 20, 1906, and the inquiry (one of the longest on record) ended on January 22, 1908, when judgment was given by the commissioners. The finding was that the primary cause of the explosion was a crack which had been formed in the end plate, owing to the bad treatment to which the plate had been subjected while being fitted into the drum. Any fears that existed as to the peculiar liability of thermal storage-drums to fail were removed. Many points of scientific interest occurred during the inquiry, notably in the reports by Mr. W. Rosenhain and Dr. T. E. Stanton, of the National Physical Laboratory, showing from the results of chemical, microscopical, and mechanical tests that the plate in question was of good normal commercial quality, but that it had received severe treatment in the hands of the boiler-makers.

Last spring Dr. J. Elberts, the German geologist, conducted an expedition to investigate further the fossiliferous deposits of the Bengawan River, near Trinil, in Java, rendered famous by the discovery of *Pithecanthropus erectus* by Dr. Eugene Dubois in 1891-2. Although extensive collections were made and fresh forms discovered, no trace of *Pithecanthropus* was found; but, according to the correspondent of the *Pall Mall Gazette* (January 17), Dr. Elberts found roughly fashioned implements of bone, "a fireplace, and the remains of extinct animals, from which he became convinced that the ape-man must have existed at a remoter period." Unfortunately, this statement is so vague that nothing can be accepted until more information comes to hand. The implication is that some beings made fires and cooked animals, now extinct, before the gravel beds were deposited which contain *Pithecanthropus* and other extinct forms. In the province of Madium a fireplace was discovered 20 feet below the surface containing stone arrow-heads and fragments of pottery, broken and partly burned bones, and charred teeth of a fossil buffalo, together with the bones of deer, pigs, and a fossil elephant (*Stegodon*); some of these bones had been split open in order to extract the marrow. Dr. Elberts computes that these people lived 20,000 years ago, but, as the correspondent of the *Pall Mall Gazette* does not give the data upon which this estimation is based, this date must await the publication of all the facts. It is evident that we may congratulate our German colleagues on having discovered remains of early inhabitants of Java who were apparently in their "Neolithic" stage of culture. It is to be hoped that when the finds are published in full it will be possible to learn what manner of men they were. We understand that the expedition is now in south Sumatra, where fossil plants will also be collected, in the hope of determining whether Sumatra had an Ice age.

THE correspondence on the winding of rivers in plains which followed the letter from Sir Oliver Lodge published in these columns on November 7 last (vol. lxxvii., p. 24), and to which Mr. J. Lomas contributed on December 5 (vol. lxxvii., p. 102), has led Dr. D. T. Smith, of Louisville, Ky., to remind us that the subject is discussed in a book of his entitled "Philosophy of Memory," which was reviewed in *NATURE* of May 18, 1899 (vol. lx., p. 51).

In his book a chapter on the laws of river flow is included, in which he expresses the opinions supported by Mr. Lomas. Dr. Smith's views were arrived at after many years of close observation of streams, ranging from rivulets to the Mississippi, on the banks of which he resides. As was said in the review of his book, his results merit careful consideration as an important contribution to the inquiry.

MR. R. I. LYNCH writes commenting on the review of "The Garden Beautiful" which was published (p. 217) in our issue of January 9. He takes exception to the remark:—"We cannot agree with the suggestion on p. 76 that trees growing in isolated positions on lawns have their roots robbed by the grasses! in anything like the measure that obtains when the trees are growing together in a plantation." Mr. Lynch reminds us of the experiments carried out at the Woburn Experimental Fruit Farm, and of the serious results that were found to follow when grass grows over the roots of a young tree. These experiments were personally inspected by our reviewer, who wrote with full knowledge of the results obtained. Mr. Lynch appears rather to have misunderstood the meaning of the sentence in the review. It was not intended to deny the deterring influence of the sward; the statement is that a tree growing on a lawn suffers less robbery at the roots from grasses than is suffered by a tree growing in a plantation, and therefore exposed to the competition caused by the encroachment of roots from adjacent trees, which in course of time must interlace. The question raised is, in fact, one of degree, and degree only.

In the course of an article on the "Atlantic flora" of Scandinavia in *Nature* for January, Mr. E. Jørgensen gives a figure, taken from a living specimen of the Lofoten variety of the fjord-horse, which affords a much better idea of this pony than does the one from a badly mounted skin in the Bergen Museum published last year by Dr. Stejneger in Smithsonian Miscellaneous Collections.

To the January number of the *Journal of Anatomy and Physiology* Dr. D. Forsyth contributes the first part of an important paper on the anatomy of the thyroid and parathyroid glands in mammals and birds, embodying the results of the examination of these organs in a large number of species. Since the conclusions are reserved for the continuation, a fuller notice of the paper may likewise be deferred. In the same issue Dr. W. L. H. Duckworth continues his account of the brain of native Australians, while Dr. Ramsay publishes additional observations on the dentition of the same race.

BULLETIN No. 56 of the University of Arizona Experiment Station is devoted to scale-insects infesting palms and the best means of exterminating these pests. One of the most troublesome, which much resembles the jujube-scale (*Parlatoria zizyphi*) commonly infesting oranges from the Mediterranean countries, and appears to belong to the same genus, was introduced on palms from North Africa. Unfortunately, it has been described independently by three different naturalists, in Italy, America, and New Zealand, under as many distinct names, of which *Parlatoria blanchardi* is entitled to stand.

To Dr. W. L. Abbott, who has previously done such good service to America by collecting in the Malay countries, the U.S. National Museum is indebted for a series of specimens of mammals from western Borneo, a notice of which is given by Mr. M. W. Lyon in No. 1577 of the Proceedings of that institution. The collection is

noteworthy for the large number of skins of the proboscimonkey. The animal referred to under the disguise of *Pongo pygmaeus pygmaeus* appears to be the orang-utan. Other recent issues of the same publication include an account of the North American parasitic copepod crustaceans of the family Caligidae (No. 1573), by Mr. C. B. Wilson, and a list of the land-shells of the family Pyramidellidae, with descriptions of new species, from the Oregon district (No. 1574), by Messrs. Dall and Bartsch.

A NOTABLE contribution to the botany of Texas is published in the eighteenth annual report of the Missouri Botanical Garden under the title of "Plantæ Lindheimerianæ, Part iii." Mr. F. Lindheimer was one of the early German pioneers in Texas, and from 1833 to 1851 made botanical collections that were to be named by Dr. G. Engelmann, of St. Louis, and Dr. Gray, and distributed among subscribers. Four fascicles were collected and distributed, and in the first two parts of "Plantæ Lindheimerianæ" determinations were given for the orders as far as Compositæ (Bentham-Hooker's sequence). The present part, prepared by Mr. J. W. Blankinship, contains a biography, the determinations for the remainders of the early fascicles, and for another series that may be regarded as fascicle v. Also the author has compiled a revised index of names for all the collections.

FERTILISATION in the genus *Cyripedium* forms the subject of a paper by Miss L. Pace published in the *Botanical Gazette* (November, 1907). The species *spectabile* and *parviflora* were examined, and the development of the embryo sac furnished results of peculiar interest. The original mother cell divides to form two daughter cells, one micropylar, the other chalazal. The nucleus of the micropylar cell rarely divides, but the nucleus of the chalazal cells divides, giving rise to two nuclei, so that three megaspore nuclei are usually produced. The chalazal cell becomes the embryo sac, in which two megaspore nuclei are used; another nuclear division completes development in the embryo sac, that contains then one egg cell, two synergids, and a polar nucleus. Fertilisation of the ovum is normal, and so-called double fertilisation is effected by the fusion of one synergid, the polar nucleus, and a male nucleus.

BOTANISTS, more especially those who favour the view that the derivation of the angiosperms should be traced through the gymnosperms, will be much interested in the theory with regard to the embryo sac advanced by Dr. O. Porsch in a small brochure published at Jena by Mr. Gustav Fischer. The original and essential points in the argument lie in the interpretation of the antipodal cells as an archegonial complex, and in homologising the polar nuclei with ventral canal cells. This postulates an archegonium consisting of an ovum and two neck cells, and a vestigial ventral canal cell nucleus at each end of the embryo sac. Dr. Porsch bases his arguments on a sequence starting from the condition of numerous archegonia found in *Sequoia* through types of the Cupressaceæ and Ephedra, where the archegonia are reduced in number and complexity, to a hypothetical case of two archegonia, at first juxtaposed, but subsequently located at the poles of the embryo sac.

IN the latest addition (No. 15) to the series of Bulletins issued by the University of Illinois, Mr. L. P. Breckenridge discusses the burning of Illinois coal without smoke. The fundamental principles that apply to smokeless furnace construction and working are enumerated, and, by means of, units in actual operation, several ways are indicated in which these principles have been satisfactorily applied.

THE report of the Chief Inspector of Mines for the year 1904-5, issued by the Mysore Geological Department (Madras, 1907), has just been received. It contains the mineral statistics for 1904, and, as regards gold mining, is a record of steady progress. The value of the gold production in 1904 was 2,323,194. The total value of gold produced from the commencement of mining operations up to the end of 1904 was 21,011,075*l.*, and the total dividends paid amounted to 9,329,487*l.* In addition to gold, statistics are given of the production of salt, iron ore, corundum, soapstone, limestone, clays, laterite, granite, and other building stones.

In a review of engineering in the United States last year, reference is made, in the *Engineer* of January 17, to the spectacular feature of building as an engineering work in the construction of the numerous steel-frame office buildings of enormous height in New York. The highest of these is the tower of the Manhattan Building, 75 feet by 85 feet, 660 feet high to the top of the cupola. This has forty-eight stories. Next to this is the tower of the Singer Building, forty-two stories, with a height of 612 feet. The main portions of these buildings are respectively eleven and fourteen stories high. On the other hand, the City Investing Company Building has the main building, twenty-five stories high, with a tower 70 feet square, having thirty-two stories, and rising to a height of 400 feet above the street. In all these cases the towers are used as offices, &c., like the main parts of the building. This requires very elaborate lift equipment, with high speeds. The city now has one building each of forty-eight, forty-two, and thirty-two stories; twenty buildings of twenty to twenty-six stories; fifty of fifteen to twenty stories; and 465 buildings of ten to fifteen stories in height.

WE have received from Dr. Eredia, of the Italian Central Meteorological Office, an article on the rainfall of the Liguria Riviera, reprinted from the *Rivista Agraria* for October, 1907. This paper, like his other useful investigations of the meteorology of various Italian provinces, collects into convenient tables the most trustworthy data relating to the object in view, and discusses them in an interesting explanatory text, dealing with monthly and seasonal values. The latter clearly show that in all seasons of the year the rainfall along the eastern Riviera is greater than along the western, and that autumn is the wettest and summer the driest period. Next to the autumn season, winter is wettest at Genoa, Spezzia, and San Remo, i.e. near the centre and extremes of the province, but at other places the greatest fall occurs in the spring. The mean yearly values are 52.8 inches at Genoa, 57.7 inches at Spezzia, and 31.9 inches at San Remo; the period dealt with is 1880-1905.

THE Cantor lectures, delivered by Mr. Conrad Beck in November and December last, have been reprinted in recent numbers of the *Journal of the Society of Arts* (December 27, 1907, to January 17); they deal with the theory of the microscope, a subject of never-failing interest, whether it be considered from the theoretical or the practical standpoint. The first lecture deals with the problem of arranging lenses so as to obtain an enlarged view of an object; although most of the matter is well known, many points are considered in a most interesting and instructive manner, as, for instance, the interpretation of the Gauss surfaces for a thick lens or system of lenses. The second lecture is concerned with the quality of the image formed. The methods of correcting certain classes of lenses for spherical and chromatic aberration

may be found in most books on geometrical optics, but the microscope objective is so complicated in its structure, and the conditions to be complied with in its design are so far different from those which determine the design of other lenses, that but scanty notice is generally given to this most important and interesting lens combination. Mr. Beck outlines the principles which must guide the designer of such a lens combination. The third lecture is devoted to the consideration of diffraction, so far as this applies to the microscope. The theory due to the late Prof. Abbe is outlined, and Mr. J. W. Gordon's criticisms of the theory are then explained; an experiment shown by Mr. Beck in his lecture proves conclusively that the Abbe theory is at fault in certain respects. The fourth lecture, which is concerned with the practical use of the microscope, should prove of great value to those who wish to employ that instrument to its greatest advantage.

MESSRS. E. B. ROSA and L. COHEN examine critically the formulæ given by different authors for the self-inductance of a circle in the *Bulletin of the Bureau of Standards* for December, 1907. They consider Wien's formula the most accurate, Maxwell's and Rayleigh's next, Minchin's, Hicks's, and Blathy's untrustworthy, and the simple formula of Kirchhoff, i.e. $L = 4\pi a(\log 8a/r - 1.75)$, in which a is the radius of the circle and r the radius of its cross-section, as a very close approximation to the correct value.

THE *Journal de Physique* for December, 1907, contains Prof. Schuster's address to the Société française de Physique on some electrical phenomena of the atmosphere and their relations with solar activity. Prof. Schuster points out that the most important free periods of oscillation of the atmosphere of the earth are, according to the calculations of Lord Rayleigh and M. Margules, about twelve and twenty-three hours, and that in consequence the semi-diurnal motions are more pronounced than the diurnal. Assuming that the conductivity of the upper atmosphere is much greater than that of the lower, he shows that the electric currents produced in the atmosphere by its motion across the earth's magnetic field are capable of explaining the diurnal variations of terrestrial magnetism. The negative charges brought down by rain drops he considers account for the maintenance of the earth's negative charge. He points out that the evidence with regard to magnetic storms and sun-spots only establishes a general connection, and does not warrant us in attributing a particular storm to a particular spot. Finally, he urges the substitution of short organised attacks on definite problems for the present rather aimless accumulation of observations carried on for such long periods at so many places.

A COPY of the prospectus of Dr. J. W. Spengel's *Ergebnisse und Fortschritte der Zoologie* (see *NATURE*, January 16, p. 246), giving a sketch of the lines upon which that serial is to be conducted, and the names of the editors for special subjects, has been received from the publisher, Mr. Gustav Fischer, Jena.

GOOD pictures often serve to direct the attention of children to the beauties of nature and to encourage them to seek out the objects themselves in order to study them at first hand. A series of beautiful slides illustrating wild bird life, all of which have been made from photographs taken from nature, submitted to us for inspection by Messrs. Sanders and Crowhurst, should certainly succeed in attracting to the observation of birds in their natural surroundings those who are fortunate enough to see them.

MESSRS. MACMILLAN AND CO., LTD., have published a third edition of "Comparative Anatomy of Vertebrates," which has been adapted from the sixth German edition of Prof. R. Wiedersheim's work by Prof. W. N. Parker. The present edition has been almost entirely re-written, and with Prof. Wiedersheim's permission, alterations desirable in the interests of English students have been made. The general plan of the original has been retained, but some portions have been extended and others abridged. The second English edition was reviewed in the issue of NATURE of September 1, 1898 (vol. lviii., p. 409), when the characteristics of this widely known student's manual were described. The price of the new edition is 16s. net.

OUR ASTRONOMICAL COLUMN.

ASTRONOMICAL OCCURRENCES IN FEBRUARY:—

- Feb. 4. 4h. 11m. Moon in conjunction with ζ and $3^{\circ} 48' S$.
 5. 6h. 22m. to 11h. 12m. Transit of Jupiter's Satellite IV. (Callisto).
 ,, 13h. 19m. to 17h. 1m. Transit of Jupiter's Satellite III. (Ganymede).
 10. 7h. 50m. Venus and Saturn in conjunction.
 11. 10h. 28m. Minimum of Algol (β Persei).
 ,, 12h. 22m. to 13h. 19m. Moon occults ζ Tauri (Mag. 3).
 13. 2h. Mercury at greatest elongation ($18^{\circ} 9' E$).
 ,, 11h. 45m. to 13h. 0m. Moon occults δ Geminoorum (Mag. 3.6).
 14. 7h. 17m. Minimum of Algol (β Persei).
 15. 2h. 7m. Moon in conjunction with Jupiter and $1^{\circ} 12' N$.
 ,, Illuminated portion of the disc of Venus = 0.797.
 27. 12h. 48m. Moon in conjunction with Uranus and $0^{\circ} 7' N$.

PHOTOGRAPHIC OBSERVATIONS OF ENCKE'S COMET (1908a).—Encke's comet was photographed at the Heidelberg Observatory on January 13, 14, 15, 18, and 19, and in No. 4229 of the *Astronomische Nachrichten* (p. 79, January 21) Prof. Wolf records the positions and magnitudes derived from the plates. On the first three dates the recorded magnitude was 12.0, on the last two 12.5. The observed positions have been compared with those given in the ephemeris, and corrections to the latter are appended; those for R.A. are fairly constant at $+3m.$, but those for declination vary from $-24^{\circ} 0'$ (December 25, 1907) to $+1^{\circ} 4'$ (January 19).

SATURN, A NEW RING SUSPECTED.—Observing at an elevation of 1550 metres, at the Revard, Pay-de-Dôme, France, under exceptionally favourable conditions on September 5, 1907, M. G. Fournier suspected a faint, transparent, and luminous ring exterior to the principal rings of Saturn. On September 7 the same observer confirmed the presence of a very pale luminous zone sharply defined at its edges, but neither he nor M. Jarry-Desloges, who communicates the discovery to the *Bulletin de la Société astronomique de France* (p. 36, January), was able to find it on September 11. The latter observer suggests the possibility that the ring is subject to periodical fluctuations of brightness, and may, therefore, only become visible at certain intervals; he also suggests that observers situated in high altitudes, such as the Arequipa and Flagstaff stations, may, alone, be able to observe this difficult detail of the Saturnian appendage. A drawing accompanying the communication shows the nebulous ring, extending beyond the principal rings, as it appeared at 22h. 25m. on September 7.

DETERMINATION OF THE MOON'S LIGHT WITH A SELENIUM PHOTOMETER.—In a recent note in these columns (p. 258, January 16) reference was made to some results obtained by Messrs. Stebbins and Brown in a determination of the brightness of moonlight by a selenium photometer (*Astrophysical Journal*, vol. xxvi., p. 326). The result was given as 0.23 candle-power, but, as there seems to be some misconception as to the meaning of this, an explanation seems desirable. American observers state quantities

of this kind in candle-metres, and thus interpreting the above result it means that the light of the full moon illuminates a white surface to the same extent as an illuminating source of 0.23 candle-power, placed at a distance of 1 metre, would illuminate it.

Owing to the colour-sensitiveness of the selenium cells being as yet unknown, this result must be accepted as purely preliminary; different cells gave results varying from 0.07 to 0.37, the mean being 0.22 candle-power, and very near to the 0.23 adopted by Müller ("Die Photometrie der Gestirne," Leipzig, 1897, p. 344) as the mean of several visual observations by different observers.

The method of observation adopted by Messrs. Stebbins and Brown was to determine at what distance from the selenium cell the standard candle would produce the same deflection as the light from the moon, and then to reduce this distance to terms of the standard candle-metre, afterwards applying the corrections for atmospheric absorption. The determinations of the variation of moonlight with the moon's phase gave consistent results for each cell, and forms the most valuable part of the work. The standard candle employed is by Max Kohl, and burns amyl acetate; the diameter of the round wick is 8 mm., and the height of the flame was regulated to 40 mm.

A USEFUL SUN AND PLANET CHART.—From the firm of Carl Zeiss we have received a copy of their chart for showing the position of the sun, or of any of the planets, at any epoch during the present year. The chart is constructed on a principle employed by Mr. R. H. Bow, of Edinburgh, and consists of two sets of curves and a star map. On the one set of curves, which is placed to the right of the star map, the declinations of the various bodies during the twelve months are shown, whilst the second set, placed directly below the star map, shows the right ascensions. To find the position of a planet on any date, the declination of the planet on that date is found on the former set of curves, and from the point thus determined a horizontal line is drawn across the star map. A vertical line is then drawn from the corresponding point on the right-ascension curve, and where these two lines intersect on the star map is the position occupied by the planet. A calendar of oppositions, quadratures, and conjunctions is also shown on the chart.

CHICAGO MEETING OF THE AMERICAN ASSOCIATION.

THE fifty-eighth meeting of the American Association for the Advancement of Science and of its affiliated scientific societies was held at Chicago from December 30, 1907, to January 4, 1908, under the presidency of Prof. E. L. Nichols, professor of chemistry at Cornell University. The attendance was estimated at about 1400, the accurate registration of the affiliated societies having not been handed in at the time of writing. The programme was one of unusual interest, and a number of important measures were adopted.

The opening meeting of the association was held on the morning of Monday, December 30. Addresses of welcome were made by Dean G. E. Vincent, of the University of Chicago, in the enforced absence of the president, Dr. H. P. Judson, and by Mr. G. E. Adams, vice-chairman of the local committee for the meeting. The retiring president, Dr. W. H. Welch, of Johns Hopkins University, introduced the president of the meeting, Prof. Nichols, who replied to the addresses of welcome. The address of the retiring president, Dr. W. H. Welch, was given on December 30 before a large audience, and consisted of a masterly treatment of the subject of the interdependence of medicine and other sciences of nature (see NATURE, January 23). At the conclusion of the address a reception was given to the members of the association and affiliated societies.

The vice-presidential addresses, that is, addresses of presidents of sections, were distributed through the week at afternoon sessions. That before Section A (mathematics and astronomy) was delivered by the retiring vice-president, Edward Kasner, of Columbia University. Its title was "Geometry and Mechanics." The address of the retiring vice-president of Section B (physics) was given by Prof.

W. C. Sabine, of Harvard University, under the title of "The Origin of the Musical Scale." The address before Section C (chemistry) was given by Mr. Clifford Richardson, of the New York Testing Laboratories, on "A Plea for the Broader Education of the Chemical Engineer." There was no address before Section D (mechanical science and engineering). The address of the retiring vice-president of Section E (geology) was delivered by Dr. A. C. Lane, State Geologist of Michigan, at the summer meeting of the section held at Lake George. The address of the retiring vice-president of Section F, Dr. E. G. Conklin, of the University of Pennsylvania, was entitled "The Mechanism of Heredity." The retiring vice-president of Section G (botany), Dr. D. T. MacDougal, of the Carnegie Institution, Washington, D.C., discoursed on "Heredity and Environic Forces." The retiring vice-president of Section H (anthropology and psychology), Prof. A. L. Kroeber, of San Francisco, spoke on "The Anthropology of California." The address before Section K (physiology and experimental medicine) was given by retiring vice-president Simon Flexner, of the Rockefeller Institute for Medical Research, New York, on the subject "Recent Advances and Present Tendencies in Pathology." An address was given before the newly established Section L (education) by the Hon. Elmer Brown, United States Commissioner of Education, on "The Future of the Section of Education."

The character of the papers read before the different sections and the affiliated societies was of a very high order. A prominent feature of the meeting was the holding of joint sessions and symposiums on subjects of allied interest. The section on mathematics and astronomy, that on mechanical science and engineering, and the Chicago branch of the American Mathematical Society, for example, held an important joint session to consider the teaching of mathematics to engineering students, in which the present status in the United States was discussed by Prof. Edgar J. Townsend, of the University of Illinois, and in other countries by Prof. Alexander Ziwet, of the University of Michigan.

Section K held an important symposium on January 1 on the subject of immunity, in which the following papers were presented after introductory remarks by the vice-president of the section, Dr. Ludwig Hektoen, of the University of Chicago:—anaphylaxis and its relation to immunity, by Dr. M. J. Rosenau and Dr. John F. Anderson, of the United States Public Health and Marine-Hospital Service (paper read by Dr. Anderson); hyper-susceptibility and immunity, by Dr. Victor C. Vaughan, of the University of Michigan; the hemolysins of animal toxins, by Dr. Preston Kyes; artificial immunity to glucosides, by Dr. W. W. Ford; the differentiation of homologous proteins by serum reactions, by Dr. S. P. Beebe; immunity in spirochaetal infections, by Dr. F. D. Novey; immunity in Rocky Mountain spotted fever, by Dr. H. T. Ricketts and Dr. L. Gomez; virulence of pneumococci in relation to phagocytosis, by Dr. E. C. Rosenow; the mechanism of streptococcus immunity, by Dr. G. F. Ruediger; immunity in tuberculosis, by Dr. M. P. Ravenel; chemical aspects of immunity, by Dr. H. Gideon Wells.

The American Society of Naturalists, in the afternoon of January 1, held an important discussion on the topic of cooperation in biological research, in which Prof. F. P. Lillie, of the University of Chicago, Dr. W. Trelease, of the Missouri Botanical Garden, Dr. H. H. Donaldson, of the Wistar Institute, Dr. Simon Flexner, of the Rockefeller Institute, Prof. W. H. Howell, of Johns Hopkins University, and Prof. J. R. Angell, of the University of Chicago, took part.

Under the auspices of Section I an important symposium was held on the subject of federal regulation of public health. This session was held jointly with the National Legislative Conference of the American Medical Association and other interested organisations. Addresses were given by Dr. W. H. Welch, Hon. George L. Shiras, Dr. Charles A. Reed (president of the National Legislative Council of the American Medical Association), and Dr. F. F. Westbrook, of the University of Minnesota. There was also a lengthy prepared discussion by representatives of the various organisations concerned.

Section G and the Botanical Society of America held a symposium on the species question, in which the taxonomic aspect was discussed by Prof. C. E. Bessey and Dr. N. L. Britton, the physiologic aspect by Dr. J. C. Arthur and Dr. D. T. MacDougal, and the ecologic aspect by Prof. F. E. Clements and Prof. H. C. Cowles.

The American Chemical Society, as usual, held a very important meeting with a lengthy programme in joint session with section C of the American Association for the Advancement of Science.

As the result of a letter from the President of the United States, Mr. Roosevelt, to the president of the association, Dr. Nichols, concerning the necessity for active measures to conserve the natural resources of the United States, resolutions were adopted announcing the importance of such an effort, and appointing a standing committee of the association to consider plans and to forward the general movement. Resolutions were also adopted favouring an increase in the facilities given by Congress to the United States Bureau of Education. Further resolutions were passed urging the establishment of a research laboratory in tropical medicine in the Isthmian Canal zone; favouring the efforts to preserve from extinction the great sea animals of the waters adjoining the United States; and urging upon Congress the establishment of an Appalachian Forest Reserve, reiterating a recommendation urged at the last meeting of the association.

At the meeting of the general committee on the night of January 2 it was decided that the next regular meeting of the association be held in Baltimore during convocation week, 1908-9, and that a summer meeting be held in the week beginning June 29 at Dartmouth College, Hanover, N.H. A resolution was also adopted recommending that arrangements be made, if possible, for a meeting in the summer of 1910 in the Hawaiian Islands.

Officers for the present year were elected as follows:—president, Prof. T. C. Chamberlin, of the University of Chicago; vice-presidents, A, no election; B, Prof. K. E. Guthe, State University of Iowa; C, Prof. L. Kahlenburg, University of Wisconsin; D, Prof. G. F. Swain, Massachusetts Institute of Technology; E, Prof. Bailey Willis, U.S. Geological Survey; F, Prof. C. J. Herrick, University of Chicago; G, Prof. H. M. Richards, Columbia University; H, Prof. R. S. Woodworth, Columbia University; I, no election; K, Prof. W. H. Howell, Johns Hopkins University; L, Prof. G. Stanley Hall, Clark University; general secretary, Prof. F. W. McNair, president Michigan School of Mines; secretary of the council, Prof. D. C. Miller, Case School of Applied Science; treasurer, Prof. R. S. Woodward, Carnegie Institution, Washington, D.C. (as before); permanent secretary, Dr. L. O. Howard, Smithsonian Institution, Washington, D.C. (as before).

STRESSES IN MASONRY DAMS.

THE stresses in masonry dams, to which much attention has recently been devoted in our correspondence columns, formed the subject of three papers read before the Institution of Civil Engineers on January 21. In the first, Sir John W. Outley, K.C.I.E., and Dr. A. W. Brightmore described some experiments, occupying about fourteen months, made with plasticine models of a dam of typical triangular section under perfect conditions. The height of the model was 30 inches, and the length of the dam 12 inches. From the results of the experiments the following conclusions were drawn:—(1) If a masonry dam be designed on the assumption that the stresses on the base are uniformly varying, and that these stresses are parallel to the resulting force acting on the base, the actual normal and shearing stresses, on both horizontal and vertical planes, would (in the absence of stresses due to such factors as changes in temperature, unequal settlement, &c.) be less than those provided for. There can be no tension on any plane at points near the outer toe. There will be tension on planes other than the horizontal plane near the inner toe, the maximum intensity of such tension being generally equal to the average intensity of shearing stress on the base, and the inclination of its plane of action being about 45°.

In the second paper Mr. J. S. Wilson and Mr. W. Gore

gave the results of an experimental investigation by means of india-rubber models. The following are some of the conclusions given:—(1) Tensile stresses may exist at the up-stream toe of a dam, notwithstanding the fact that the line of resistance lies well within the middle third. The tension may be reduced by (a) making the up-stream face vertical, or by otherwise increasing the weight of the dam toward that face; this would have the effect of increasing the stresses in the dam when the reservoir is empty; (b) by a general increase in the dimensions of the dam; (c) by placing an earth embankment against the down-stream face. (2) The direct stresses at the down-stream toe are compressive in every direction, but reduce to zero in the direction normal to the face. (3) The maximum compressive stresses in a dam above its foundations are in a direction approximately parallel with the down-stream face, and generally some distance therefrom. In magnitude they are slightly greater than

$$\frac{P_r}{\cos^2 \phi}$$

where P_r is the maximum normal pressure on a horizontal plane as determined by the trapezium law, and ϕ is the angle between the resultant and the vertical. (4) The shearing stresses are considerable at or near the up-stream toe. They are a maximum a short distance from the down-stream face, in a plane approximately at 45° to the face. The maximum shearing stresses are in magnitude equal to

$$\frac{P_r}{2 \cos^2 \phi}$$

(5) The stresses in the foundations are of less consequence than in the dam above the base, because of the lateral support and the more extended distribution. (6) The stresses are considerable at the toes of a dam if they form sharp angles with the foundations. These stresses may be reduced by replacing the angles with curves of large radii. The curve at the up-stream toe may take the form of a rounded quin, cut in large stones, so as to avoid joints, in the masonry, normal to the direction of the greatest tensile stress.

In the third paper Mr. E. P. Hill described a method of determining stresses based on the assumption that the vertical pressure on the base varies uniformly from one side to the other.

AUSTRIAN SCIENCE.

THE monthly parts of the *Sitzungsberichte* of the Vienna Academy of Sciences which appeared last year show that there is no falling off in the research work carried out at the Austrian universities in the fields of mathematics and natural philosophy. Prof. Lecher, of Prague, has verified Ohm's law by showing that there is no difference in the resistance of a silver or platinum wire when a small or a large electric current passes through it, provided its temperature is the same in both cases. Assuming that the current is carried by one type of free electron, he deduces a velocity of propagation of electricity in ordinary cases of the order of a few centimetres per second.

Prof. F. Exner and Dr. E. Haschek have been engaged in a search for the cause of the slight variability of wavelength of many of the spectral lines with the method of excitation. They are disposed to attribute it to the lines for which it has been observed being complex, with satellites of variable intensity or number which appear to be present more frequently on the red than on the blue side of the line. In an instrument of only moderate resolving power, the apparent effect of any cause tending to increase the intensity of such satellites with respect to the original line will be a displacement of the line towards the red end of the spectrum.

Dr. N. Stücker has investigated the sensitiveness of a great number of persons to small differences of pitch in different parts of the musical scale. He finds that in general the region of maximum sensitiveness is in the octaves c^1 and c^2 , where about $1/20$ th of a tone can be detected. A few musical people were able to detect a difference of $1/20$ th of a tone in this region. The higher

limits of audibility varied from about 40,000 in general to more than 60,000 in the case of musicians.

The meteorological side of the activity of the academy is well represented by Dr. F. M. Exner's outlines of a theory of variation of atmospheric pressure. The principal result of this investigation is that the pressure variations may be represented by the motion of a relatively permanent system of isobars over the surface of the earth from west to east with a velocity varying slightly with the season.

An important series of papers by Prof. Rudolph Wegscheider and Dr. Heinrich Walter, published in the *Sitzungsberichte* (vol. cxvi., pp. 443, 455, and 533), throws a great deal of light on the phenomena occurring when soda is causticised by means of lime. On the one hand, the conditions of equilibrium for the reversible change $\text{Ca}(\text{OH})_2 + \text{Na}_2\text{CO}_3 = \text{CaCO}_3 + 2\text{NaOH}$ have been ascertained at different temperatures; that the change is a reversible one is shown by the fact that the same condition of equilibrium is established at a definite temperature whether the lime acts on sodium carbonate or caustic soda on calcium carbonate. The change in the direction from left to right seems to be more complete at 80° than at 106° – 110° , and to occur more readily in dilute than in concentrated solutions; the way in which it is influenced by concentration is considered at some length from the standpoint of the theory of mass action. The loss of sodium carbonate which may occur in the more concentrated solutions owing to the formation of the mixed carbonate, $\text{CaCO}_3 \cdot \text{Na}_2\text{CO}_3$, is also fully dealt with, the conditions under which gaylussite, $\text{CaNa}_2(\text{CO}_3)_2 \cdot 5\text{H}_2\text{O}$, and pirsonite, $\text{CaNa}_2(\text{CO}_3)_2 \cdot 2\text{H}_2\text{O}$, are capable of existence in contact with solutions of sodium carbonate and caustic soda being defined for different temperatures. It is noteworthy that the decomposition of both of the double salts by water is retarded owing to the formation of a protective sheath of insoluble calcium carbonate on the surface of the particles, so that if the mixed salt is once precipitated owing to the concentration becoming too great, loss of sodium carbonate may occur even though the insoluble material be well washed. The whole investigation has a special interest as illustrating the applicability of recently developed views in pure chemistry to the elucidation of technical problems.

During several years past the study of the general laws of esterification, especially of the influence exercised by structural peculiarities on the phenomena, has formed a special feature of the research work carried out under the direction of Prof. Wegscheider in the first chemical laboratory of Vienna University. The results obtained have, in particular, thrown considerable light on the nature of the so-called "steric hindrance." In continuation of these researches a series of papers by Anton Kailan appears in the *Sitzungsberichte* of the academy dealing with the esterification of the dinitrobenzoic acids, of mono- and di-hydroxybenzoic acids, and of pyridinemonocarboxylic acids by alcoholic hydrogen chloride. Prof. Wegscheider and E. Frankel discuss in considerable detail the reasons for abnormalities which sometimes are found to characterise the action of alkyl haloids on metallic salts of organic acids. The peculiar influence exercised by the presence of a small proportion of water on the rate of formation of ethyl chloride from alcohol and hydrogen chloride is the subject of a paper by A. Kailan, in which it is shown that the velocity constants of the action are proportional to the concentration of the hydrogen chloride only in absolute alcohol. In alcohol containing water, even in 99.9 per cent. alcohol, an increase in the concentration of the hydrogen chloride is found to be accompanied by a considerably greater increase in the velocity constant.

To vol. cxvi. of the *Sitzungsberichte* (*mathematisch-naturwissenschaftliche Klasse*) of the academy Mr. F. Siebenrock contributes a monographic revision of the American tortoises of the family Cionosternidae, in which several changes in the generally accepted classification are proposed. In the British Museum Catalogue of Chelonians the family is taken to include only the single genus Cionosternum, while Claudius and Staurotypus are included with Dermatemyx in the family Dermatemydidae. This the author regards as an unnatural arrangement, and he proposes to transfer Claudius and Staurotypus to the Cion-

sternidae, in which they form the subfamily Staurotypanæ. Mr. Siebenrock goes, however, even further than this, and suggests that the Cinosternidae should be brigaded with the Chelydridæ in one sectional group—the Chelydroidea; while the families Dermatemydidae and Platysternidae are regarded as more nearly related to the Testudinidae, with which they should form the group Testudinoida. For the structural details on which the author justifies this radical change in taxonomy, reference must be made to the paper itself.

Morphologists will find much to interest them in an article in the same volume by Mr. Max Holl, of Graz, on the anatomy of the hind portion of the cerebral lobes in man and apes. The author appears to have been led to undertake the investigation by finding one human brain which differed most remarkably in regard to the arrangement and complexity of the postero-lateral sulci from all others which had come under his observation. His studies have, however, shown that there is a great amount of variation in this respect in human brains, and he has in consequence been led to recognise two principal types. To the more primitive of these he gives the name pithecoïd and to the other that of anthropoid, type. Between the two there exists, however, an almost complete gradation. By far the greatest degree of individual variation in the form of the postero-lateral region of the brains of Primates occurs in the case of the tropical American spider-monkeys of the genus *Ateles*.

Attention may likewise be directed to a paper by Dr. Karl Blyoff in the same volume on the structure and life-history of the blood-parasites *Trypanosoma lewisi* and *T. brucei*. New methods of staining microscopic preparations have enabled the author to bring to light certain previously unknown features in connection with these organisms. The various developmental stages assumed by trypanosomes in mammalian blood are the result of division of adult forms. High magnifying power has revealed the presence of pseudopodia-like projections at the "hind extremity" of both species of trypanosomes, but which these are constant morphological features or merely temporary developments has yet to be demonstrated.

THE CENTENARY OF DAVY'S DISCOVERY OF THE METALS OF THE ALKALIS.¹

A HUNDRED years ago last October, there happened one of those events to which the term epoch-making may, without cavil or question, be fittingly applied.

As it was an occurrence with which the name and fame of the Royal Institution are inseparably bound up, the managers have thought it only proper that its centenary should not pass unnoticed here, and it is by their wish, therefore, that I appear on this the first possible opportunity after the actual date of its hundredth anniversary to give you some account of it, and to state, so far as I am able and within the limits of an hour, the fruitful consequences that have flowed from it.

Let me, in the first place, attempt to recall the circumstances which led up to that cardinal discovery of which to-night we celebrate the centenary. These are connected partly with the institution itself and partly with the state of science in the early years of the nineteenth century.

In the year 1807 this institution was entering upon the eighth year of its existence. As you doubtless know, the Royal Institution grew out of a proposal to deal with the question of the unemployed, namely, by forming in London by private subscription an establishment for feeding the poor and giving them useful employment, and also for furnishing food at a cheap rate to others who may stand in need of such assistance, connected with an institution for introducing and bringing forward into general use new inventions and improvements, particularly such as relate to the management of heat and the saving of fuel, and to various other mechanical contrivances by which domestic comfort and economy may be promoted. Such was the original prospectus, but, like many other prospectuses, it failed to equal the promise its projectors held out.

¹ A lecture delivered at the Royal Institution of Great Britain, on Friday, January 17, by Prof. F. E. Thorpe, C.B., F.R.S.

Eventually the promoters decided, on the initiation of Count Rumford, that the Associated Institution would, as they expressed it, be "too conspicuous and too interesting and important to be made an appendix to any other existing establishment," and therefore it ought to stand alone on its own proper basis.

Accordingly, the problem of the unemployed still remains with us, whilst the new institution took the form of converting Mr. Mellish's house in Albemarle Street into a place where, by regular courses of philosophical lectures and experiments, the applications of the new discoveries in science to the improvement of the arts and manufactures might be taught, so as to facilitate the means of procuring the comforts and conveniences of life.

The Royal Institution had a troubled infancy. Like the poor it was originally designed to succour, it suffered much in the outset from lack of nourishment. To add to its miseries, the little starveling was caricatured by Gillray, lampooned by Peter Pindar, and ridiculed by Lord Brougham, and it was literally in the throes of dissolution when new life was breathed into it by the opportune arrival, in 1801, of a small spare youth of twenty-two from Bristol, whom the managers had engaged at a salary of 100 guineas a year. The youth was Humphry Davy, who had acted as assistant to Dr. Beddoes, of the Pneumatic Institution, and who had already made some slight stir in scientific circles by his discovery of a characteristic property of nitrous oxide. In announcing his arrival to the managers, Count Rumford reported that he had purchased a cheap second-hand carpet for Mr. Davy's room, together with such other articles as appeared to him necessary to make the room habitable, and among the rest a new sofa-bed, which, in order that it may serve as a model for imitation, had been made complete in all its parts. Six weeks after his arrival Davy was called upon to lecture, and a descriptive paragraph of the period thus chronicles his success in the *Philosophical Magazine* for 1801:—

"It must give pleasure to our readers to learn that this new and useful institution, the object of which is the application of Science to the common purposes of life, may be now considered as settled on a firm basis.

"We have also to notice a course of lectures, just commenced at the institution, on a new branch of philosophy—we mean the Galvanic (or Bristol) Phenomena. On this interesting branch, Mr. Davy (late of Bristol) gave the first lecture on the 25th of April. He began with the history of Galvanism, detailed the successive discoveries, and described the different methods of accumulating galvanic influence. . . . He showed the effect of galvanism on the legs of frogs, and exhibited some interesting experiments on the galvanic effects on the solution of metals in acids. Sir Joseph Banks, Count Rumford, and other distinguished philosophers were present. The audience were highly gratified, and testified their satisfaction by general applause. Mr. Davy, who appears to be very young, acquitted himself admirably well; from the sparkling intelligence of his eye, his animated manner, and the *tonit ensemble*, we have no doubt of his attaining a distinguished eminence."

And what was of more immediate consequence, this confident assurance was shared also by the managers, for at a subsequent meeting they unanimously resolved "that Mr. Humphry Davy, director of the chemical laboratory, having given satisfactory proofs of his talents as a lecturer, should be appointed, and in future denominated, lecturer in chemistry at the Royal Institution, instead of continuing to occupy the place of assistant lecturer, which he has hitherto filled."

That such shrewd experienced men of the world as Sir Joseph Banks and Count Rumford, who were the moving spirits in the management of the institution and genuinely solicitous for its welfare, should thus entrust its fortunes, then at their lowest ebb, to the power and ability of a young and comparatively unknown man, barely out of his teens, seems, even in an age which was familiar with the spectacle of "a proud boy" as a Prime Minister, like the desperate throw of a gambler.

But Banks and Rumford had, doubtless, good reason for the faith that was in them. For a happy combination of circumstances had served to bring the Cornish youth within the range of many who could be of service to him in that search for the fame for which he hungered. His

connection with the Beddoes brought him the friendship of the Edgeworths, and it is amusing to trace how the good-humoured patronage of the gifted Maria quickly passed into amazement and ended in awe as her acquaintance with him ripened. Living in Bristol, he was at length brought into that remarkable literary coterie which distinguished that city at the close of the eighteenth century. Southey spoke of him as a miraculous young man, whose talents he could only wonder at. Cottle, the publisher, on one occasion said to Coleridge, "You have doubtless seen a great many of what are called the cleverest men—how do you estimate Davy in comparison with these?" Mr. Coleridge's reply was strong and expressive. "Why, Davy can eat them all! There is an energy, an elasticity, in his mind which enables him to seize on and analyse all questions, pushing them to their legitimate consequences. Every subject in Davy's mind has the principle of vitality. Living thoughts spring up like turf under his feet."

Davy's experimental work on "the pleasure-giving air" had made him known to the Watts and the Wedgwoods. Priestley, then in exile, and Hope, of Edinburgh, were greatly impressed with the philosophical acumen of the author of phosphygen, and he had a powerful friend in his own countyman Davies Gilbert, who succeeded him in the presidential chair of the Royal Society. We need be in no doubt, therefore, as to the influences which conspired to bring Davy into what he termed "the great hot-bed of human power called London."

The mention of Davy's first course of lectures in this institution brings me at once to the proper subject of this discourse.

The first year of the last century is memorable for the invention of the voltaic battery and for its immediate application by Nicholson and Carlisle in this country to the electrolytic decomposition of water.

Davy himself has said:—"The voltaic battery was an alarm bell to experimenters in every part of Europe; and it served no less for demonstrating new properties in electricity, and for establishing the laws of this science, than as an instrument of discovery in other branches of knowledge; exhibiting relations between subjects before apparently without connection, and serving as a bond of unity between chemical and physical philosophy."

We owe it to Sir Joseph Banks that Volta's great discovery was first made known to English men of science, and the study of the phenomena of galvanic electricity was at once entered upon by a score of experimenters in this country. Among them was Davy. Even before he left Bristol he was hard at work on the subject, sending the results of his observations to Nicholson's Journal in a series of short papers. He resumed his inquiries immediately on his arrival in London, and was doubtless well prepared, therefore, for his opening course of lectures.

In 1801 he sent his first communication to the Royal Society on "An Account of some Galvanic Combinations formed by the Arrangement of Single Metallic Plates and Fluids, Analogous to the New Galvanic Apparatus of Mr. Volta." Although the work was continually interrupted by requests made to him by the managers to carry out their own ideas of facilitating the means of procuring the comforts and conveniences of life, he never lost sight of the subject of voltaic electricity, and in spite of innumerable distractions due to the precarious position of the institution, he gradually accumulated the material out of which grew his first Bakerian lecture, "On some Chemical Agencies of Electricity," read before the Royal Society on November 20, 1806. I have ventured elsewhere to express my opinion of this paper. In my judgment it constitutes, in reality, Davy's greatest claim as a philosopher to our admiration and gratitude, for in it he, for the first time, succeeded in unravelling the fundamental laws of electrochemistry, and thereby imported a new order of conceptions, altogether unlooked for and undreamt of, into science.

I am only at the moment concerned with this memoir in its relation to the discovery of which to-night we celebrate the centenary. The isolation of the metals of the alkalis was unquestionably an achievement of the highest brilliancy, and as such appeals strongly to the popular imagination. But it was only the necessary and

consequential link in a chain of discovery which, had Davy neglected to make it, would have been immediately forged by another.

The publication of Davy's first Bakerian lecture produced a great sensation, both at home and abroad. Berzelius, years afterwards, spoke of it as one of the most remarkable memoirs that had ever enriched the theory of chemistry. Very significant, too, of the impression it made on the world of science was the action of the French Institute. Bonaparte, then First Consul, had announced his intention of founding a medal "for the best experiment which should be made in the course of each year on the galvanic fluid," and a committee of the institute, consisting of Laplace, Halle, Coulomb, Haüy, and Biot, was appointed to consider the best means of giving effect to the wishes of the First Consul. To the young man, with the little brown head, like a boy (as Lady Brownrigg described him), now twenty-eight years of age, was awarded the medal. All the institute got from the founder of the medal was what Maria Edgeworth termed "a rating all round in imperial Billingsgate." There was no *entente cordiale* in those days; indeed, the feeling of animosity was intense. Of course, there were persons who said that patriotism should forbid the acceptance of the award. Davy's own view was more sensible and politic:—"Some people," he said to his friend Poole, "say I ought not to accept this prize; and there have been foolish paragraphs in the papers to that effect; but if the two countries or Governments are at war, the men of science are not. That would, indeed, be a civil war of the worst description; we should rather, through the instrumentality of men of science, soften the asperities of national hostility."

Thanks to the kindness of Dr. Humphry Davy Rolleston, the grandson of Dr. John Davy, the brother of Sir Humphry, who has also been so good as to lend me this admirable bust of the great chemist by Chantrey, and this charming portrait by Jackson, I am able to show you this evening this historically interesting medal.

What Davy looked like at this period of his life may be seen from the picture I now project upon the screen. It is a reproduction of the large portrait which hangs in the vestibule, and which the institution owes to the thoughtful kindness of the late Mr. Graham Young.

As the applications of voltaic electricity seemed in 1806 to have no immediate bearing on the comforts and conveniences of life, Davy, during the greater part of the following year, was required to direct his attention to other matters. But in the late summer of 1807 he was able to resume his work with the voltaic battery, and he commenced to study its action on the alkalis.

That the alkalis—potash and soda—would turn out to be compound substances was not an unfamiliar idea at the time, and it is significant that almost immediately after Nicholson and Carlisle had resolved water into its elements by the action of voltaic electricity, Henry, of Manchester, the friend and collaborator of Dalton, should have made the attempt to apply the same agency to the separation of the presumed metallic principle of potash. The conception that what the older chemists called "earths" might be made to yield metals was at least as old as the time of Boyle, and probably dates back from the earliest days of alchemy. The relation of the earths to the metals was part of the doctrine of Becher and Stahl; it was no less a part of the antiphlogistic doctrine of Lavoisier, although the points of view were diametrically opposed. Neumann attempted to obtain a metal from lime, Bergman considered that baryta was, like lime, a metallic calx, and Baron that alumina contained a metal. From their many analogies to these substances it was not unreasonable, therefore, to surmise that potash and soda might also contain metallic principles.

I have elsewhere pointed out that there is some evidence that whilst at Bristol Davy had already attacked the problem of the resolution of the alkalis by means of voltaic electricity. What precise idea he had in again attacking it, or what expectation he had of a definite result, is difficult to determine. In one of his lectures on electrochemical science, delivered some time subsequently, he said he had a suspicion at the time that potash might turn out to be "phosphorus or sulphur united to nitrogen,"

conceiving that, as the volatile alkali was composed of the light inflammable hydrogen united to nitrogen, so the fixed and denser alkalis might be composed of the denser inflammable bodies—phosphorus and sulphur—also united to nitrogen.

Davy once said that "analogy was the fruitful parent of error," and few more striking instances of perverted analogy are to be met with in science than this. In another of his lectures he said of the alchemists that "even their failures developed some unsought-for object partaking of the marvellous"; and if such had been his reasoning, the statement is no less true of himself.

So far as can be ascertained, it was on October 19, 1807, that he obtained his first decisive result. This is thus described in Davy's own handwriting in the *Laboratory Journal*, which has been preserved for us by the pious care of Faraday, and which is one of the most precious of the historical possessions of the Royal Institution:—"When potash was introduced into a tube having a platinum wire attached to it, so [fig.], and fused into the tube so as to be a conductor—i.e. so as to contain just water enough, though solid—and inserted over mercury, when the platinum was made negative, no gas was formed and the mercury became oxidated, and a small quantity of the alkaligen was produced round the platinum wire, as was evident from its quick inflammation by the action of water. When the mercury was made the negative, gas was developed in great quantities from the positive wire, and none from the negative mercury, and this gas proved to be pure oxygen—a capital experiment, proving the decomposition of potash." On the 19th of the following month he delivered what is generally regarded as the most memorable of all his Bakerian lectures. It is entitled "On some New Phenomena of Chemical Changes produced by Electricity, Particularly the Decomposition of the Fixed Alkalies; and the Exhibition of the New Substances which Constitute their Bases; and on the General Nature of Alkaline Bodies."

Few discoveries of like magnitude have been made and perfected in so short a time, and few memoirs have been more momentous in result than that which, put together in a few hours, gave the results of that discovery to the world.

The whole work was done under conditions of great mental excitement. His cousin, Edmund Davy, who at the time acted as his assistant, relates that when he saw the minute globules of the quicksilver-like metal burst through the crust of potash and take fire, his joy knew no bounds; he actually danced about the room in ecstacy, and it was some time before he was sufficiently composed to continue his experiments.

The rapidity with which he accumulated results after this first feeling of delicious delight had passed was extraordinary, and he had obtained most of the leading facts concerning the physics and chemistry of the new substances before the middle of November.

He began his lecture with a felicitous reference to the concluding remarks of the one of the previous year, namely, "That the new methods of investigation promised to lead to a more intimate knowledge than had hitherto been obtained concerning the true elements of bodies. This conjecture, then sanctioned only by strong analogies, I am now happy to be able to support by some conclusive facts."

In the first attempts he made to decompose the fixed alkalis he acted upon concentrated aqueous solutions of potash and soda with the highest electrical power he could then command at the Royal Institution, viz. from voltaic batteries containing twenty-three plates of copper and zinc of 12 inches square, 100 plates of 6 inches, and 150 of 4 inches, charged with solutions of alum and nitric acid; but although there was high intensity of action, nothing but hydrogen and oxygen was disengaged. He next tried potash in igneous fusion, and here the results were more encouraging; there were obvious and striking signs of decomposition; combustible matter was produced, accompanied with flame and a most intense light. He had observed that although potash, when dry, is a non-conductor, it readily conducts when it becomes damp by exposure to air, and in this state "fuses and decomposes by strong electrical powers."

Let me state in his own words, for the words are classical, what followed:—

"A small piece of pure potash, which had been exposed for a few seconds to the atmosphere, so as to give conductive power to the surface, was placed upon an insulated disc of platinum, connected with the negative side of the battery of the power of 250 of 6 and 4 [that is 100 plates of 6 inches square and 150 plates of 4 inches square] in a state of intense activity; and a platinum wire communicating with the positive side was brought in contact with the upper surface of the alkali. . . . Under these circumstances a vivid action was soon observed to take place. The potash began to fuse at both its points of electrization. There was a violent effervescence at the upper surface; at the lower, or negative surface, there was no liberation of elastic fluid; but small globules, having a high metallic lustre, and being precisely similar in visible characters to quicksilver, appeared, some of which burnt with explosion and bright flame, as soon as they were formed, and others remained, and were merely tarnished, and finally covered by a white film which formed on their surfaces."

He goes on to say:—

"Soda, when acted upon in the same manner as potash, exhibited an analogous result; but the decomposition demanded greater intensity of action in the batteries, or the alkali was required to be in much thinner and smaller pieces.

"The substance produced from potash remained fluid at the temperature of the atmosphere at the time of its production; that from soda, which was fluid in the degree of heat of the alkali during its formation, became solid on cooling, and appeared having the lustre of silver."

It would seem from this description of its properties that the potassium Davy first obtained was alloyed with sodium owing to the fact that the potash contained soda. Potassium is solid up to 143° F., whereas, as Davy was the first to show, an alloy of potassium and sodium is fluid at ordinary temperatures.

On account of their alterability in contact with air, Davy had considerable difficulty in preserving and confining the new substances so as to examine their properties. As he says, like the alchemists imagined by the alchemists, they acted more or less upon almost every body to which they were exposed. Eventually, he found they might be preserved in mineral phosphorus.

The "basis" of potash was described by him as a soft malleable solid with the lustre of polished silver.

"At about the freezing point of water it becomes harder and brittle, and when broken in fragments, exhibits a crystallised texture which in the microscope seems composed of beautiful facets of a perfect whiteness and high metallic splendour. It may be converted into vapour below a red heat, and may be distilled unchanged, and is a perfect conductor of heat and electricity. Its most marked difference from the common run of metals is its extraordinary low specific gravity." At the time of its discovery it was the lightest solid known.

The "basis" of soda was found to have somewhat similar properties. It was slightly heavier than the "basis" of potash, and fused at a higher temperature.

Davy next examined the behaviour of the new substances towards a large number of reagents, but as his observations are now the common property of the textbooks, it is unnecessary here to dwell upon them.

He then enters upon some general observations on the relations of the "bases" of potash and soda to other bodies:—

"Should the bases of potash and soda be called metals? The greater number of philosophical persons," he says, "to whom this question has been put, have answered in the affirmative. They agree with metals in opacity, lustre, malleability, conducting powers as to heat and electricity; and in their qualities of chemical combination.

"Their low specific gravity does not appear a sufficient reason for making them a new class; for amongst the metals themselves there are remarkable differences in this respect. . . . In the philosophical division of the classes of bodies, the analogy between the greater number of properties must always be the foundation of arrangement."

"On this idea, in naming the bases of potash and soda, it will be proper to adopt the termination which by common consent has been applied to other newly discovered metals, and which, though originally Latin, is now naturalised in our language.

"Potassium (*sic*) and sodium are the names by which I have ventured to call the new substances; and whatever changes of theory, with regard to the composition of bodies, may hereafter take place, these terms can scarcely express an error; for they may be considered as implying simply the metals produced from potash and soda. I have consulted with many of the most eminent scientific persons in this country upon the methods of derivation, and the one I have adopted has been the one most generally approved. It is perhaps more significant than elegant. But it was not possible to found names upon specific properties not common to both; and though a name for the basis of soda might have been borrowed from the Greek, yet an analogous one could not have been applied to that of potash, for the ancients do not seem to have distinguished between the two alkalis."

Such, then, are the more significant features of one of the greatest discoveries ever made by a British chemist, as these are set forth in one of the most remarkable papers in the *Philosophical Transactions of the Royal Society*.

The publication of Davy's discovery created an extraordinary sensation throughout the civilised world, a sensation not less profound, and certainly more general from its very nature, than that which attended his lecture of the previous year. But at the very moment of his triumph it seemed that the noise of the universal acclaim with which it was received was not to reach him. I have already made reference to the condition of mental excitement under which the discovery was made and prosecuted. Almost immediately after the delivery of his lecture he collapsed, struck down by an illness which nearly proved fatal, and for weeks his life hung on a thread. He had been in a low, feverish condition for some time previously, and a great dread had fallen upon him that he should die before he had completed his discoveries. It was in this condition of body and mind that he had applied himself to the task of putting together an account of his results. Four days after this was given to the world he took to his bed, and he remained there for nine weeks. Such a blow following hard on the heels of such a triumph aroused the liveliest sympathy. The doors of the Royal Institution were beset by anxious inquirers, and written reports of his condition at various periods of the day had to be posted in the hall. The strength of the feeling may be gleaned, too, from the sentences with which the Rev. Dr. Dibdin, who had been hurriedly engaged to take his place in the theatre, began the lecture introductory to the session of 1808:—

"The managers of this institution have requested me to impart to you that intelligence, which no one who is alive to the best feelings of human nature can hear without the mixed emotion of sorrow and delight.

"Mr. Davy, whose frequent and powerful addresses from this place, supported by his ingenious experiments, have been so long and so well known to you, has, for the last five weeks, been struggling between life and death. The effects of these experiments recently made in illustration of his late splendid discovery, added to consequent bodily weakness, brought on a fever so violent as to threaten the extinction of life. Over him it might emphatically be said in the language of our immortal Milton, that

"... Death his dart
Shook, but delayed to strike."

"If it had pleased Providence to deprive the world of all further benefit from his original talents and intense application, there has certainly been sufficient already effected by him to entitle him to be classed among the brightest scientific luminaries of his country."

After having, "at the particular request of the managers," given an outline of Davy's investigations, Dr. Dibdin proceeded to say:—

"These may justly be placed among the most brilliant and valuable discoveries which have ever been made in chemistry, for a great chasm in the chemical system has

been filled up; a blaze of light has been diffused over that part which before was utterly dark; and new views have been opened, so numerous and interesting, that the more any man who is versed in chemistry reflects on them, the more he finds to admire and heighten his expectation of future important results.

"Mr. Davy's name, in consequence of these discoveries, will be always recorded in the annals of science amongst those of the most illustrious philosophers of his time. His country, with reason, will be proud of him, and it is no small honour to the Royal Institution that these great discoveries have been made within its walls—in that laboratory, and by those instruments which, from the zeal of promoting useful knowledge, have, with so much propriety, been placed at the disposal and for the use of its most excellent professor of chemistry."

And now, in the few minutes that remain to me, let me indicate what has been the outcome of this great and fundamental discovery. How far has the expectation of future important results been realised? Have sodium and potassium at all justified the hope that they would facilitate the means of procuring the comforts and conveniences of life?

I have not the time, even if I had the intention, to attempt to follow the many changes in the metallurgy of the metals of the alkalis of the past century. Let me at once proceed to show how the matter stands at the end of a hundred years.

The general properties and chemical activities of potassium and sodium are so very similar that, as a matter of commercial production, that metal which can be most economically obtained is necessarily the one most largely manufactured, and of the two that metal is sodium. To-day, sodium is made by thousands of tons, and by a process which in principle is identical with that by which it was first made by Davy, *i.e.* by the electrolysis of fused caustic soda. It is very significant that after a series of revolutions in its manufacture, sodium, having been produced from time to time on a manufacturing scale by a variety of metallurgical methods involving purely thermal processes of reduction and distillation, entirely dissociated from electricity, we should have now got back to the very principle of the process which first brought the metal to light. And that this has been industrially possible is entirely owing to another of Davy's discoveries—possibly indeed the greatest of them all—Michael Faraday. As we all gratefully acknowledge, it is to the genius and labours of Faraday—Davy's successor in this place—that the astonishing development of the application of electrical energy which characterises this age has taken its rise.

The modern method of production of sodium is based, therefore, as regards principles, upon the conjoint labours of Davy and Faraday.

These principles took their present form of application at the hands of a remarkably talented American—Mr. Hamilton Y. Castner—whose too early death, in the full vigour of his intellectual powers, was an incalculable loss to metallurgical chemistry. It is by Castner's process that all the sodium of to-day is manufactured.

In the Castner process melted caustic soda, produced by the electrolysis of a solution of common salt by a method also devised by Castner, is brought into an iron vessel shaped like a large cauldron, mounted on brickwork, and provided with an extension adapted to receive the negative electrode. Suspended directly above the kathode is an iron vessel attached to a lid; to its lower edge is secured iron wire gauze, which, when the receptacle is in position, completely surrounds the kathode. The positive electrode is connected with the lid of the vessel, which is provided with openings for the escape of the gases resulting from the electrolysis, and is suitably insulated.

As the electrolysis proceeds, the alkali metal, being much lighter than the molten caustic, rises from the negative electrode and passes into the receiver, the gases escaping around the edges of the cover. The molten metal collects on the surface of the caustic, and is removed by means of a large perforated spoon, the perforations enabling the melted caustic to flow out, while the metal remains in the spoon. As the several vessels are thus skimmed in succession, the fused sodium is collected into an iron vessel, whence it is poured into moulds, in which

it congeals, forming blocks of the size and shape of an ordinary building brick. These, after being trimmed to remove adherent oxide, are immersed in paraffin oil, and are then packed into large iron drums holding about 6 cwt. or 7 cwt., capable of being closed airtight, and protected in transit by an outer casing of wood.

The due regulation of the volume and intensity of the current is a matter of the greatest importance in order to obtain the most economical yield of the metal. No very high temperature is needed; indeed, the temperature of the fused caustic soda should not be much higher than that of its melting point. By suitably regulating the current, the soda, in fact, may be maintained at the proper temperature and in the proper degree of fluidity without extraneous heat. Fresh melted caustic soda is added to the vessel from time to time to replace the metal removed, and in this manner the process is made continuous.

The Castner process is now worked in England at Wallsend-on-Tyne, and at Weston Point, in Cheshire; at Rheinfelden, in Germany; at Clavaux, in France; also in Switzerland, and at Niagara, in America. The present yearly output amounts to about 5000 tons, but the plant already laid down is capable of producing at least twice this quantity.

The greater quantity of the sodium made in England is sent to Glasgow, where it is converted into sodium cyanide by the Cassel Cyanide Company for use in the extraction of gold. As gold is, I suppose, generally considered the principal material factor in procuring the comforts and conveniences of life, Davy's great discovery may be thus said to have secured the primary object which the projectors of the Royal Institution had in view. Other important uses of sodium are in the manufacture of peroxide for bleaching purposes, of artificial indigo, and of a number of other synthetic dye-stuffs and of drugs like antipyrin.

It need hardly be said that this extraordinary development of the manufacture has not been without its influence on the price of sodium. A quarter of a century ago it was a comparatively rare metal, and a stick of it was regarded as a chemical curiosity, to be handled with circumspection and care. Even as late as 1890 its selling price was as high as 8s. per lb. To-day it is 8d. Sodium now takes rank, therefore, with zinc, tin, copper, or aluminium as a common, ordinary metal of commerce.

I am indebted to the directors of the Castner-Kellner Company, and in particular to my friends Sir Henry Roscoe and Mr. Beilby, for affording me the opportunity, in connection with this lecture, of actually witnessing the modern process of manufacturing sodium as it is carried out at Wallsend, and I am further indebted to Mr. Beilby for the loan of the lantern-slides and specimens with which I have sought to illustrate that process.

And in concluding may I be permitted to recall here the feelings to which that visit to Wallsend gave rise? There, grouped together on the very spot where ended the old wall—the visible symbol of the power and might of a civilisation long since passed away—were some of the characteristic signs of another civilisation ampler and more beneficent. Before me, stretching down to the river, was the factory where a score of workers, clad in helmets and gauntlets, and swathed like so many Knights Templar, their visages lit up by the yellow soda flames, and their ears half-deafened with the sound of exploding hydrogen—a veritable inferno—were repeating on a Gargantuan scale the little experiment first made a century ago in the cellars of this building, turning out, day and night, tons of the plastic metal in place of the little pin-heads which then burst upon the astonished and delighted gaze of Davy. Behind me was the magnificent power-house—one of the most magnificent of its kind in the world—furnishing not only the electrical energy which transformed the soda into sodium, but diffusing this energy for a multitude of other purposes over an entire district—a noble temple to the genius and prescience of Faraday. Surely one might here say, if you desire to see the monuments of these men, look around! And to my right, and close at hand, was the huge building slip just vacated by the *Maurætania*, herself a symbol of the supremacy of an empire, far mightier, more world-wide, and more potent for good, than that which massed its legions behind the old wall.

UNIVERSITY AND EDUCATIONAL INTELLIGENCE.

CAMBRIDGE.—The electors to the Allen scholarship give notice that they are prepared to receive applications from candidates. Any graduate of the University is eligible for the scholarship provided that his age on the first day of the Lent term 1908 does not exceed twenty-eight years. This year the scholarship is open to candidates who propose to undertake research in any branch of study which comes within the department of any of the following special boards:—medicine, mathematics, physics and chemistry, biology and geology. The scholarship is tenable for one year, during which period it will be the duty of the student to devote himself to research in Cambridge or elsewhere. The emolument of the student is 250*l.*, or such smaller sum as the fund, after payment of all expenses, shall be capable of providing. Every candidate must send particulars of his qualifications, &c., to the Vice-Chancellor, Gonville and Caius College Lodge, on or before February 15.

MANCHESTER.—The following brief summary of some recently published statistics serves to illustrate the development in the work of the University during the past eight years. The table not only indicates that a considerable increase has taken place in the numbers of students and staff, but also shows that the progress has been particularly marked in the fields of advanced study and research. The growing success of the honours schools in both science and arts is particularly worthy of notice:—

	End of 1899	End of 1907
Professors	30	43
Total teaching staff... ..	98	203
Students taking full day courses... ..	900	1400
Science honours students	97	180
Arts honours students	34	106
Graduate and research students in residence	—	141
Research fellows and students pursuing original work	—	55

By the will of the late Mr. Basil McCrea, the Magee Presbyterian College, Londonderry, receives several substantial benefactions. Among these gifts occur 14,000*l.* for building and equipping a new lecture hall; a sum to endow two professorships, to be known respectively as the "Henry Wallace" and the "William Archer Butler" professorships, each professor to receive an annual stipend of 300*l.*; a sum to found and endow two lectureships in the science department of the college, each lecturer to receive an annual stipend of 150*l.*, and to be known as the "McCrea lecturers"; such annual sum as may be necessary to make up the stipends of each of the professorships in the literary and science departments to 300*l.* per annum; 500*l.* each year to found and endow a "McCrea science scholarship" and a "McCrea literary scholarship," each of the value of 100*l.*, to be competed for every third year, and any surplus to be used for "McCrea prizes" in the science and literary departments.

At a recent meeting of the governors of the Glasgow and West of Scotland Technical College it was intimated that the Glasgow City Educational Endowments Board had made a further grant of 1000*l.* to the building fund of the college, and that the trustees of the Bellahouston Bequest Fund had promised a donation of 5000*l.* on condition that the governors raised a further sum of 45,000*l.* Including these grants, the building fund now amounts to 301,000*l.* The governors of the college have just resolved to raise the standard of the preliminary examination for admission to the course for the college diploma to that of the Leaving Certificate of the Scotch Education Department. The holders of this certificate are exempted from the preliminary examination of the Scottish universities. This raising of the standard of the entrance examination by the governors of the great technical college at Glasgow represents a new departure of high significance in technical education. Now that the courses will be based upon a preparatory training equal to that demanded by any British university, it will be possible to make substantial advance in the quality of the work undertaken.

A SCHEME to prepare girls better to undertake the duties of the home was described in a letter to the *Times* of January 24. The communication was signed by Prof. William Osler, F.R.S., Sir Henry Roscoe, F.R.S., and Prof. A. Smithells, F.R.S., with others. Instruction of the kind required is impossible without teachers capable of giving it, and the first step must be, the letter points out, to provide education of an advanced type for those who will hereafter conduct the work in its more elementary stages. It is therefore proposed to provide in London a course of post-graduate instruction in household economics. The course will be given at the women's department of King's College, and will begin next October. A college board, consisting mainly of the professors of the subjects germane to the course, with Prof. Smithells acting as honorary adviser, will control the educational side of the work. It is hoped that it will be found possible to include courses of training for the management of large educational and other institutions, for the duties of factory inspection, and for social work aimed at raising the standard of home life. Donations are asked for in order to raise 3000*l.*, the sum necessary for the effective organisation of the scheme, and may be sent to Miss Soltau, King's College (Women's Department), 13 Kensington Square, W.

THE best results are obtained in those technical schools where the students are encouraged to follow a suitable course of training extending over a number of years, and where the instruction provided is suited exactly to the industrial requirements of the district. The latest report of the Board of Education states in this connection:—"Well-considered programmes of instruction within schools and careful adjustment of the relation of school to school in populous areas have become more common. In an increased number of schools we find teachers at pains to urge continuity of study and to order their teaching so as to help towards this end. Opportunities for advanced work are provided more widely than before, and accordingly we find the period of study extending and the number of students of mature years increasing." To mark still more obviously the importance of continuity of study, the Board has given prominence to an arrangement by which the Board and the school authorities join in responsibility for the issue of "technical course certificates" affording suitable records of completed curricula. These certificates are to be given only in connection with courses each approved as providing such a technical education as will have a definite value in relation to the occupation to which it has regard. Each certificate as awarded by the local education authority or the managers of a school and endorsed by the Board will record continued attendance and satisfactory attainments in the several sections of the specified course of instruction. The system thus initiated appears to be capable of considerable development. It may become a valuable feature in the organisation of technical courses—standardising their aims and encouraging the students to persistent attendance and continuity of study. The statistics in connection with the examination of students in evening schools, too, the report points out, reflect both the improvement in the provision of more advanced classes and the increased regularity of the attendance of the students.

SOCIETIES AND ACADEMIES.

LONDON.

Royal Society, November 7, 1907.—"The Electrical Discharge in Monatomic Gases." By F. SODDY and T. D. MACKENZIE. Communicated by Prof. J. Larmor, Sec.R.S.

Helium and argon purified by volatilising calcium (Soddy, Proc. Roy. Soc., 1907, lxxviii, A, 429) from traces of common gases show a disinclination to conduct the discharge, and the question arises whether the monatomic gases in a perfectly pure state will conduct at all. The well-known phenomenon of "running out" or exhaustion of spectrum tubes filled with these gases with prolonged use might be due to absorption of the impurities only by the electrodes leaving the pure monatomic gases in a non-conducting state. This question has been exhaustively investigated, and the conclusion is drawn that the mon-

atomic gases conduct in the same manner as common gases, but are relatively electrically, as well as chemically, inert. That is to say, the various stages of the discharge from the X-ray vacuum to the ribbon discharge when considerable quantities of gas are present are produced in the case of helium, for example, at pressures from five to ten times the pressure required to produce the same stage of the discharge in a gas like hydrogen or nitrogen.

The "running out" of spectrum tubes filled with monatomic gases under the discharge is due to absorption of the monatomic gas principally in the film of aluminium volatilised from the electrodes. In one series of experiments six tubes were filled with helium purified by calcium at the initial pressures 1.1 mm., 2.3 mm., 4.9 mm., 8.6 mm., 16.8 mm., and 31.2 mm. The first three became non-conducting—the discharge passing an alternative spark gap of an inch of air, and the tube fluorescing strongly—with less than an hour's running, and the fourth after sixty hours, the residual pressure of pure helium in each case being about 0.7 mm. This was determined by breaking the tube under mercury, and confirmed by the use of a specially designed form of McLeod gauge. In the first case the mercury rapidly liberated the greater part of the occluded gas by dissolving the film of volatilised aluminium. The occluded gases are also slowly evolved spontaneously in the cold, and practically completely when the tube is heated to its softening point for some time.

X-rays are given out in pure helium at pressures below 0.2 mm. in an X-ray tube 8 cm. diameter, while in hydrogen X-rays are not given out until the pressure is reduced below 0.1 mm. It is probable that the real pressure in an X-ray tube is in no case below 0.01 mm., and the general impression that the pressure is of the order of 0.001 mm. is due to a variety of misapprehensions regarding high vacua. The behaviour of argon, neon, mercury vapour, nitrogen, and carbon dioxide has also been investigated.

The behaviour of helium at low pressures, at which it conducts the discharge with abnormal difficulty, is strictly analogous to its behaviour at high pressures, when it conducts with abnormal facility (Ramsay and Collie, Proc. Roy. Soc., 1896, lix, p. 257). The curves connecting discharge potential and pressure were taken in the same tube for helium and hydrogen. Helium at 60 mm. showed the same discharge potential (7750 volts) as hydrogen at 12 mm. At a pressure of 30 mm. the potential in helium was 3400 volts, and in hydrogen 16,000 volts. Throughout the whole region, both of high and low pressure, one hydrogen molecule is electrically equivalent, so far as its effect on the character of the discharge is concerned, to several helium molecules.

The remarkable observation was made that some new spectrum tubes, as obtained from the maker, generated helium during preparation and the removal of the occluded gases. The only escape from the conclusion that helium was formed under the special conditions to which the tubes had been subjected was that the helium was derived from the aluminium electrodes. Experiments were made with old aluminium electrodes which had been exposed for months to the air after removal from old spectrum tubes in which they had been used with the rare gases. By the help of the calcium method it was proved that helium, neon, and argon can be obtained in this way in quantities sufficient to give a clear spectrum from old aluminium electrodes which have been used with these gases.

All the spectrum tubes used showed strongly Campbell Swinton's effect (Proc. Roy. Soc., 1907, A, vol. lxxix, p. 134) of developing minute bubbles when fused, usually in the areas exposed to the bombardment of particles travelling normally from the surface of the electrodes; but the argon tubes showed the effect to an extraordinary extent, the glass appearing to boil when fused. Experiments are described in which these glasses have been subjected to a temperature of 1300° C. in a vacuum furnace, and all but the inert gases absorbed by calcium. Only the minutest trace of rare gas is ever obtained in this way, and this is quite insufficient to produce the effect. In the case of the glass of a helium tube which showed Campbell Swinton's effect strongly, it was proved that after a preliminary heating in a vacuum, at a temperature below that necessary to produce bubbles, to drive off surface

gas, not the faintest trace of helium was obtained. The view is put forward that the effect is due to a secondary decomposition of the glass under local heating during the bombardment, and that it is not due to the discharge gases being driven into the glass.

Royal Microscopical Society, December 18, 1907.—Mr. Conrad Beck, vice-president, in the chair.—Specimens of luminous bacteria: J. E. **Barnard**. On the room being darkened, the light given off by the bacteria was at once apparent, and the contents of the flask when shaken became very luminous. The light produced was nearly monochromatic, lying between the lines F and G of the spectrum. The whole energy of these bacteria seemed to be utilised in producing light, no heat whatever being detected.—Specimens of natural twin-crystals of selenite: E. **Large**. Specimens were also exhibited under special reflecting polariscopes; under some of these were also shown artistic subjects made from selenite, one representing a vase of flowers, and another flowers and fruits, with animals, such as parrots, chameleons, &c., which changed colour when a film of mica below the design was rotated. Mr. Large also exhibited a small double-image prism made from a fragment of Iceland spar and mounted on the nose of an objective, by means of which two images of a suitable object placed on the stage with a selenite plate were obtained in complementary colours.—Gregory and Wright's microscope: E. M. **Nelson**. This microscope was described and illustrated in an old and rare book published by Gregory and Wright in 1786, and was called a "new universal microscope, which has all the uses of the single, compound, opaque and aquatic microscopes." The illustration shows it to be very similar to one presented to the society in 1809 by Dr. Dallinger, which was then thought to have been made by Benj. Martin, but it now seems likely that it was made by Gregory and Wright, who were probably Martin's successors.—A correction for a spectro-scope: E. M. **Nelson**. The paper described a device by which the object-glass of the telescope may be automatically rotated so as always to receive the rays from any part of the spectrum without obliquity.—Some African rotifers: J. **Murray**. The paper described about twelve species of Bdelloid rotifers from Old Calabar, Uganda, and Madagascar, among which were one new species and two new varieties.

January 15.—Mr. E. J. Spitta in the chair.—A new method of showing living bacteria by dark-ground illumination: C. **Beck**. The apparatus consisted of a modified parabolic illuminator, a Nernst lamp, and monochromatic blue light filter.—Some microscopes of new design made by Messrs. Leitz: J. W. **Ogilvy**. The instruments were fitted with Leitz's fine adjustment, the arrangement consisting of a worm wheel and heart-shaped cam, which gives an alternate rise and fall of 3 mm. to the body of the microscope. Mr. Ogilvy said an important feature in the arrangement was that, in the event of the objective being brought into contact with the cover glass when focussing, it simply rested upon the slide, no further downward motion being imparted to the body even if the observer continued to turn the milled head. The coarse adjustment was also provided with a safety arrangement.—The microscope as an aid to the study of biology in entomology, with particular reference to the food of insects: W. **Wesché**.

EDINBURGH.

Royal Society, January 6.—Prof. Crum Brown, F.R.S., vice-president, in the chair.—The chairman read a preliminary obituary notice of the late president, Lord Kelvin (see p. 253).—The fossil *Osmundaceæ*, part ii.: D. T. **Gwynne-Vaughan** and R. **Kidston**, F.R.S. The present part begins with a full account of the synonymy of scorial fern stems of *Osmundaceæ* affinity from the Permian of Russia. The internal structure of two of these, *Zalasskya gracilis* and *Z. diploxylon* (the latter a new species), is described in detail. They form a primitive genus of the *Osmundaceæ*, and are especially characterised by the possession of a broad and perfectly continuous ring of xylem, from which the leaf-tracheæ depart in protostelic manner. The xylem is non-parenchymatous, and most of the tracheæ bear multiseriate pits. The protoxylems of the leaf-tracheæ are shortly decurrent into the stele of the stem

as mesarch strands dying out rapidly below. Two distinctly different regions are to be observed in the xylem, a peripheral zone of normal tracheæ and a central mass of short and wide elements with reticulate markings. In the living plant of *Z. diploxylon* the latter tissue occupied the whole of the centre of the stele, which therefore possessed a solid central mass of xylem. It follows that the central ground-tissue of the recent *Osmundaceæ* must be regarded as a true pith derived from the modified central xylem of such a stele. The phloem consists of metaphloem only, there being no proto-phloem or porous layers.

PARIS.

Academy of Sciences, January 20.—M. Henri Becquerel, in the chair.—The principal earthquake centres in France, and on the system of seismic stations that should be established: G. **Bigourdan**. Taking into account the stations already existing or now being established, further stations are suggested at Nice, Marscilles, Rennes, and Lille.—Concerning a tooth discovered by MM. Maurice de Rothschild and H. Neuville: Albert **Gaudry**. It is concluded that this tusk, found near Addis-Abeba, belongs to a large unknown African mammal, now existing or recently extinct.—Morphological variations, obtained artificially, of the tubercle bacillus of man and mammals: S. **Arling**. An account, accompanied by reproductions of photographs, of the modifications produced in human and bovine tubercle bacilli by prolonged cultivation at either a high temperature (45°) or high pressure (2.5 atmospheres).—A differential system of the second degree: L. **Schlesinger**.—The periodic solutions of certain functional equations: Ernest **Eslangon**.—Methodical attempts at a cellular aeroplane: H. **Farman**. A detailed account of the steps by which the author constructed his aeroplane and learnt its use.—The efficiency of screws for propulsion in the air: Louis **Breguet**.—The study of radio-active lead: B. **Szilard**. Radium D, E, and F have been separated from radio-lead. The present paper is concerned with the best methods of effecting this separation.—An exceptional case of Zeeman's phenomenon: A. **Dufour**. It is shown that there exists at least one source of light, a flame in which calcium fluoride is volatilised, giving a spectrum attributed to a compound and not to an element, which, placed in a magnetic field, gives out circular vibrations the sense of which agrees with the hypothesis of the existence of positive electrons.—The calorimetric method applied to the study of slow reactions: Jacques **Duclaux**. A closed Dewar tube is used as the calorimetric vessel, the whole being placed in the water of a thermostat. As showing the accuracy obtainable, an example of the application of the method to the hydrolysis of ethyl acetate by potash is given.—The synthesis of ammonia: M. **Wolterck**.—The catalytic power of silica and alumina: J. B. **Senderens**. The catalytic effect produced by silica or alumina depends upon the state of division and also upon the temperature to which these substances have been raised. Thus precipitated silica, dried by a gentle ignition, at 280° acts upon alcohol giving 99.5 per cent. of ethylene. The same silica, calcined for one hour at a red heat, gives ethylene and 5.3 per cent. of hydrogen. After six hours' ignition, the decomposition takes place only at 300°, and the amount of hydrogen increases to 17 per cent. Alumina behaves in a similar manner.—Some compounds of terbium and dysprosium: G. **Urbain** and G. **Jantsch**. Salts of these elements having been recently isolated in a pure state by the authors, they have studied the properties of some of their compounds with the view of devising less tedious methods of separation. The present note contains an account of terbium peroxide, Tb₂O₃; nitrate, Tb(NO₃)₃·6H₂O; sulphate, Tb₂(SO₄)₃·8H₂O; and chloride, TbCl₃·6H₂O. Dysprosium does not form a peroxide, but the properties of the nitrate, Dy(NO₃)₃·8H₂O; sulphate, Dy₂(SO₄)₃·8H₂O; and chloride, DyCl₃·6H₂O, are described.—The heats of solution of the alkali metals and the heats of formation of their protoxides: E. **Rengade**. On account of the violence of the action of water upon these metals, especially cesium and rubidium, the reaction was allowed to take place in a modified Berthelot bomb. The results are very concordant, and lower than those previously obtained by other methods.—The estimation of sulphide of carbon in

benzenes: Isidore Bay. The carbon bisulphide is precipitated by phenylhydrazine, the precipitate washed with pure benzene, and dried *in vacuo*.—The transformation of the α -oxyacids into aldehydes by boiling their mercuric salts in aqueous solution; application to the preparation of *l*-arabinose by means of mercuric gluconate: Marcel Cuerbet.—Some cases of the simultaneous production of the 1:6- and 2:7-dimethylanthracenes: James Lavaux.—Syntheses by means of ethyl and methyl adipates: L. Bouvaut and R. Locquin.—The action of nascent hypiodous acid (iodine and sodium carbonate) on some acids of the general formula $R.CH_2.CH_2.CO.H$, R being C₂H₅, more or less substituted: J. Bougault.—Some mineral salts which can act as peroxides: J. Wolff.—A new type of polychaetal annelid: Ch. Gravier.—The oculo-reaction in its relation to previous treatment with tuberculin: H. Vallée.—A bacilliform piroplasmiosis observed in cattle in the neighbourhood of Algiers: H. Soulié and G. Roig.

GÖTTINGEN.

Royal Society of Sciences.—The *Nachrichten* (physico-mathematical section), part iv, for 1907, contains the following memoirs communicated to the society:—

January 12.—Seismic waves. (1) Theory of the propagation of seismic waves; (2) seismic time-curves: E. Wiechert and K. Zoeppritz.

July 6.—The uniformisation of algebraic curves: P. Koebe.

July 20.—Researches from the Göttingen University chemical laboratory, xviii. (1) The synthesis from nopinone of a hydrocarbon related to β -pinene; (2) the synthesis of homologous compounds of the dipentene series; (3) syntheses in the terpinene series; (4) the synthesis of anethol from anise-aldehyde, and of isosafrol from piperonal; (5) the occurrence of sabinene in Ceylon oil of cardamoms and majorana oil; (6) isomeric camphenes and a new camphen-camphor acid; (7) condensation products of cyclic ketones with aromatic aldehydes: O. Wallach.

August 6.—A contribution to our knowledge of the light-sense in chickens: D. Katz and G. Révész.

The official communications (part ii., 1906), just published, include a report by E. Klein on the progress of the issue of Gauss's works.

DIARY OF SOCIETIES.

THURSDAY, JANUARY 30.

ROYAL SOCIETY, at 4.30.—On the Observation of Sun and Stars made in some British Stone Circles. Third Note: The Aberdeenshire Circles: Sir Norman Lockyer, K.C.B., F.R.S.—On the Non-periodic or Residual Motion of Water moving in Stationary Waves: Mrs. Avron.—The Refractive Index and Dispersion of Light in Argon and Helium: W. Burton.—On the Generation of a Luminous Glow in an Exhausted Receiver moving near an Electrostatic Field, and the Action of a Magnetic Field on the Glow so produced: Rev. F. J. Jervis-Smith, F.R.S.

FRIDAY, JANUARY 31.

ROYAL INSTITUTION, at 9.—Recent Researches on Radio-activity: Prof. E. Rutherford, F.R.S.

MONDAY, FEBRUARY 2.

VICTORIA INSTITUTE, at 4.30.—The Southern Alps of New Zealand and their Glaciers: C. D. Fox.
ARISTOTELIAN SOCIETY, at 8.—The Religious Emotion; Some Results of Inductive Enquiry: Dr. A. Caldercut.
SOCIETY OF CHEMICAL INDUSTRY, at 8.—Nitro-glycerine and its Manufacture: Lieut.-Col. Sir Frederick Nathan and W. Rintoul.

TUESDAY, FEBRUARY 4.

ROYAL INSTITUTION, at 3.—Roman Britain: (6) Its Interior Civilisation: Prof. F. J. Hawfield.
INSTITUTION OF CIVIL ENGINEERS, at 8.—Further discussion: Experimental Investigations of the Stresses in Masonry Dams subjected to Water Pressure: Sir J. W. Outley, K.C.I.E., and Dr. A. W. Brightmore.—Stresses in Dams; an Experimental Investigation by Means of India-rubber Models: J. S. Wilson and W. Gore.—Stresses in Masonry Dams: E. P. Hill.

ZOOLOGICAL SOCIETY, at 8.30.—Cinematograph Demonstration of Results of Natural Colour Photography with Zoological Subjects: F. Martin Duncan.—The Duke of Bedford's Zoological Exploration in Eastern Asia. VII. List of Mammals from the Eschschia Islands: O. Thomas.—On the Presence of Gonadal Grooves in *Aurelia aurita*: T. Gosdev.—The Duke of Bedford's Zoological Exploration in Eastern Asia. VIII. A Collection of Freshwater Fishes from Corea: C. Tate Regan.

WEDNESDAY, FEBRUARY 5.

GEOLOGICAL SOCIETY, at 8.—On Antigone and the Val Antigorio, with Notes on other Serpentes containing that Mineral: Prof. T. G. Bonney, F.R.S.—The St. David's Head "Rock Series" (Pembrokeshire): J. V. Ellen.

ENTOMOLOGICAL SOCIETY, at 8.—On Diapomatism, with Reference to

some Limitations of the Millerian Hypothesis of Mimicry: Guy A. K. Marshall.

SOCIETY OF ARTS, at 8.—War Balloons: A. E. Gaudron.

THURSDAY, FEBRUARY 6.

ROYAL SOCIETY, at 4.30.—*Probable Papers*.—On the Weight of Precipitin obtainable in Precipitin Interactions with Small Weights of Homologous Protein: Prof. Dr. A. Welch and H. G. Chypan.—Nitrication of Acid Soils: A. D. Hall, N. H. J. Miller, and C. T. Gimmingham.—A Criticism of the Oponic Theory based upon Studies carried out by Means of Melanin: S. G. Shattuck and L. S. Dudgeon.—A Contribution to the Study of the Mechanism of Respiration, with Especial Reference to the Action of the Vertebral Column and Diaphragm: J. F. Halls Dally.

ROYAL INSTITUTION, at 3.—The Story of the Spanish Armada: Major Martin Hunt.

INSTITUTION OF ELECTRICAL ENGINEERS, at 8.—Protective Devices for High Tension Transmission Circuits: J. S. Peck.

LINNEAN SOCIETY, at 8.—Fruits and Seeds from the Pre-Glacial Beds of Britain and the Netherlands: Clement Reid, F.R.S.—On a Method of Disintegrating Peat and other Deposits containing Fossil Seeds: Mrs. Reid.—On a Botanical Expedition to Fokien: S. T. Dunn.

CIVIL AND MECHANICAL ENGINEERS' SOCIETY, at 8.—Some Devices for the Absorption of Shock on Wheeled Vehicles: F. G. Woollard.

CHEMICAL SOCIETY, at 8.30.—The Metallic Picrates: O. Silberrad and H. A. Phillips.—Organic Derivatives of Silicon. Part V. Benzylethylsilicone, Dibenzylsilicone and other Benzyl- and Benzylethyl-derivatives of Silicon: R. Robison and F. S. Kipping.—Some Physico-chemical Properties of Mixtures of Pyridine and Water: H. Hartley, N. G. Thomas, and M. P. Appleby.—The Constitution of Umbellulone, Part III: F. T.utin.—The Residual Affinity of the Coumarins and Thio-coumarins as shown by their Additive Compounds: A. Clayton.—The Influence of Foreign Substances on Certain Transition Temperatures, and the Determination of Molecular Weights: H. M. Dawson and C. G. Jackson.—The Bromination of β -Hydroxydiphenylamine: Miss A. E. Smith and K. J. P. Orton.—Colour and Constitution of α -Methine Compounds, Part I: F. G. Pope.—The Decomposition of Ammonium Bichromate by Heat. Preliminary Notice: W. M. Hooton.

FRIDAY, FEBRUARY 7.

ROYAL INSTITUTION, at 6.—Napier and the Lighthouse: Humphry Ward.

SOCIETY OF ARTS, at 8.—The Hygiene of the Pottery Trade: W. Burton.

INSTITUTION OF CIVIL ENGINEERS, at 8.—Electric Hardening and Annealing Furnaces: P. T. Steintahl.

GEOLOGICAL ASSOCIATION, at 8.—Presidential Address: The Centenary of the Geological Society: R. S. Herries.

JUNIOR INSTITUTION OF ENGINEERS, at 8.—Aerial Navigation: H. Chatley.

CONTENTS.

	PAGE
The Function of the Stapes. By M. G.	289
Life and Death	289
Philosophical Essays. By W. B.	290
Primitive Interpretations	291
Our Book Shelf:—	
Bailey: "Cyclopaedia of American Agriculture"	292
"Penrose's Pictorial Annual, 1907-8"	292
Remington: "The Education of To-morrow"	292
Biden-Powell: "Scouting for Boys. A Handbook for Instruction in Good Citizenship"	293
"Photograms of the Year 1907"	293
Letters to the Editor:—	
Stability in Flight.—A. Mallock, F.R.S.	293
The Inheritance of "Acquired" Characters.—Dr. G. Archdall Reid	293
The Melanic Variety of the "Peppered" Moth.—A. Baco	294
Inductance in Parallel Wires.—Dr. J. W. Nicholson	295
Stock Frost or Ground Ice.—Rev. John J. Hampson	295
The Production and Manipulation of India-Rubber. (Illustrated.) By C. Simmonds	296
Scenery and Natural History of New Zealand. (Illustrated.) By Prof. Arthur Dendy	297
Lieut.-Col. R. L. J. Ellery, C.M.G., F.R.S	298
Notes	298
Our Astronomical Column:—	
Astronomical Occurrences in February	302
Photographic Observations of Encke's Comet (1908a)	302
Saturn, a New Ring Suspected	302
Determination of the Moon's Light with a Selenium Photometer	302
A Useful Sun and Planet Chart	302
Chicago Meeting of the American Association	302
Stresses in Masonry Dams	303
Austrian Science	304
The Centenary of Davy's Discovery of the Metals of the Alkalis. By Prof. T. E. Thorpe, C.B., F.R.S	305
University and Educational Intelligence	309
Societies and Academies	310
Diary of Societies	312

THURSDAY, FEBRUARY 6, 1908.

TRANSPIRATION AND ANATOMICAL
STRUCTURE IN TROPICAL PLANTS.

Der Einfluss des Klimas auf den Bau der Pflanzengewebe. Anatomisch-physiologische Untersuchungen in den Tropen. By Dr. Carl Holtermann. Pp. viii+249; plates. (Leipzig: W. Engelmann, 1907.) Price 12 marks.

DR. HOLTERMANN'S investigations, mainly carried out in Ceylon, include a long series of experiments on the transpiration of different tropical plants. His tables show great variations in the amount of transpiration for the same plant during the same hours of different days, and these are in many cases not explained by the differing temperature and relative humidity, which are the only other data given. Thus, for instance, in the case of *Canna indica*, between 9.40 a.m. and 5.40 p.m. on January 11 (with a relative humidity of 61 and a temperature of 25°·4 at 10 a.m.), the transpiration was 0·37 gr. per hour per sq. dm. of leaf surface, while on January 17, between 9.45 a.m. and 5.30 p.m. (R.H. 63, temp. 26°·2, at 11.15 a.m.), the transpiration was 0·92 gr. per hour per sq. dm., and on January 18 between 9.15 a.m. and 3.30 p.m. the transpiration was 2·60 gr. per hour per sq. dm. (no humidity or temperature data are given within the period of the experiment, but judging from the late afternoon figures the day did not differ much from the others). This, though an extreme case, is only one out of several similar ones, and the effect of such figures on the reader is decidedly bewildering, though the striking variations may be explicable by changes of insolation, or the irregular occurrence of drying winds. As they stand, the author's figures only demonstrate that the transpiration of the plants studied exhibited startlingly wide fluctuations which remain quite unexplained.

The author's general conclusion from his experiments is that while the highest transpiration figures per hour in the tropics are considerably higher than any north European ones, yet active transpiration begins later and stops earlier in the day in the case of a damp tropical climate, so that the daily average is no higher than in Europe, while in the wet season transpiration may cease for weeks at a time. He thus does not disagree with the conclusions either of Haberlandt or of Giltay on this question. Dr. Holtermann holds that water-tissue is essentially an arrangement to supply water to the transpiring tissues during these short periods of excessive evaporation, not a means of lessening transpiration, and this view he supports by showing that it is especially developed in actively transpiring plants liable to be subjected to these sudden demands. It is characteristic of the leaves of tropical plants growing in a climate which is neither quite xerophytic nor constantly moist, and this harmonises with the short daily period of very active transpiration already mentioned. The mangroves, which ordinarily possess characteristic water

tissue well developed, form much less or none at all in the leaves of examples cultivated in garden soil, which transpire very much more freely than plants growing in the natural salty soil. If these plants cultivated without salt are now watered with 3 per cent. salt solution and placed in the sun, they show a wilting of the leaves, and the mesophyll becomes shrivelled. Mangroves growing in their natural habitat also show wilting on hot afternoons, but only the water-tissue is partially emptied and the leaves recover during the night. For the rest the author holds that the xerophily of mangroves and of other halophytes has been much overrated by Schimper and others. They are scarcely, if at all, more protected in this respect than many trees growing in similar situations but not in a salty soil.

Dr. Holtermann describes three other formations of strand-plants besides the mangroves, viz., first the plants of moist sand, which fall into two categories, (1) those growing on the edge of the sea, absorbing salt water, and possessing water-tissue; (2) those growing further from the sea, with fresh bottom-water, which have no special xerophilous adaptations. Secondly, the dune plants, a highly xerophilous type; and, thirdly, the plants growing on salty mud, which have internal water-tissue, and resemble succulent desert-plants in many anatomical features. These three formations have close parallels among the strand formations of temperate regions. This classification is good so far as it goes, but it ignores the beach-jungle (*Barringtonia*-formation of Schimper), which the author apparently includes with the damp lowland forest type. Yet this formation, though not well developed in Ceylon, certainly has an independent existence; it is much in need of exact study and delimitation.

The author goes on to describe the damp lowland woods, the dry plains of the north and east, and the upland vegetation, as also the epiphytes and parasites of Ceylon. Many interesting observations are contained in this part of the work. Dr. Holtermann also discusses at some length the question of leaf-fall in the tropics, and concludes that though it is a hereditary character, it is, in the endemic species, determined by the dry season, and, in general, leaves fall when their structure does not fit them to withstand the conditions prevailing during the time the trees are bare. A similar explanation is given of the occurrence of annual rings of growth in the wood, the author relating the renewed formation of wide xylem elements to the increased transpiration taking place when a crop of young leaves is produced.

The final section of the work is devoted to a discussion of "Direct Adaptation," in the course of which an account is given of many interesting experiments which add considerably to our knowledge of adaptive reactions under new conditions. The author rightly classes all these as phenomena of irritability, but draws the conclusion that such characters, acquired during the lifetime of the individual, can in process of time be fixed and inherited. This conclusion is, of course, wholly unwarranted; in fact, it is totally irrelevant. And meanwhile the mystery of

adaptive reaction, so widespread a phenomenon in the biological world, remains unsolved. Until we know a great deal more than we do at present about the physico-chemical connection of stimulus and response it is likely to remain so.

A. G. T.

CLIMATE AND MAN.

The Pulse of Asia: a Journey in Central Asia illustrating the Geographic Basis of History. By Ellsworth Huntington. Pp. xxi+416. (London: A. Constable and Co., Ltd.; Boston and New York: Houghton, Mifflin and Co., 1907.) Price 14s. net.

IN NATURE, vol. lxxvii., 1905, p. 366, some account was given of the expedition of the Carnegie Institution of Washington to Eastern Persia and Turkestan. Mr. Huntington showed his descriptive power in the joint memoir issued in that year; and he dedicates his new book to Prof. W. M. Davis, his instructor in the "rational science" of geography, and his companion in arduous travel. Mr. Huntington states that, thanks to the help of Prof. Davis, he spent three years in Central Asia, in addition to four previously spent in Asia Minor. His study of languages has again and again been of service to him; and it is interesting to note at one point (p. 153) the struggle between his natural sympathy and the need for a little self-assertion, which, to the Oriental, is an outward sign of self-respect. His relations with the Khirghiz, and even with the feebler Chantos, were pleasant in the extreme; we fancy that something more fundamental than a training in geography gave him his thoughtful perception of the conditions and limitations of their lives.

The map of Asia, and no small part of it, is required to reveal the significance of the author's routes. The high passes of the Kwen Lun and Tian Shan ranges are mere incidents in these loops of travel, which lead us from Batum across Bokhara, and as far east as the shrinking salt-lake of Lop Nor.

Nine months were spent in the Lop Basin alone, and one of the finest things in the book is the general account of the succession of physical and climatic zones (chapter iv.), as one descends from the mountains across a ring of river-gravels to the edge of the region of desiccation. Here the fine sands and muds of old flood-plains are to-day whirled up before the wind, and are deposited as loess on the mountain-pastures to the south. The life of the nomadic inhabitants of the basin is practically limited by this pastoral land, which occupies all but the highest parts of the plateau-zone; and this zone terminates in steep slopes inwards, rising "like a continental ring around a sea forever dry." Down below, patches of forest-land are already poisoned by salt, and dying tamarisk bushes mark the spread and triumph of the desert.

All through Mr. Huntington's chapters we trace the same compelling influence. The desert, with its rippled and shifting dunes, its "hateful haze" swept onward by the wind, its inexorable hostility, demanding an inexorable endurance (p. 260), is driving man steadily before it, and has him, as it were, over leagues of country, by the throat. Old irrigation-channels have been abandoned, from failure at their source;

old roads around lake-basins have given place to direct tracks across their floors. Even in mountain-gorges, streams have run dry, leaving the lower ground dependent on the sudden and dangerous torrents that follow on each melting of the snows. Springs may temporarily arise in desiccated areas, and may furnish real rivers as time goes on (p. 182); but such incidents only temporarily retard the retreat of man, who leaves lost cities behind him, still "beautiful in the clean, graceful shrouds of their interment in the sand." Archaeological research, local legends, the experience of recent generations, all show that the drying up of Central Asia is a continuous phenomenon; yet a "climatic pulsation" in an opposite direction is traceable, both in the Caspian and Lop Nor Basins, in the "Middle Ages" following on 500 A.D.

The conditions of the still older dry or "interfluvial" epoch have not even now been reproduced, since (p. 351) there are places in the Tian Shan range, now too cold and wet for agriculture, where canals were once made to provide for irrigation. Mr. Huntington throughout acknowledges the work of Brückner and his other predecessors in these fields of travel, observation, and deduction, and has, in his later pages, urged the climatic aspect of human movements to an almost hazardous extreme. He set out (p. 6) to use Central Asia as a text "to show the immense influence which changes of climate have exerted upon history." In this respect his book does not quite rise to the anticipated level, which is reached more nearly in the memoir issued by the Carnegie Institution. But, with its simple record of perilous adventures, its excellent illustrations, and its clear devotion to science first of all, it forms a noteworthy and inspiring work of travel. Throughout it we feel, as the author means us to feel, the insistent pressure of natural law against the will and work of mortals—the helplessness of millions of men against the untimed pulse of Asia.

GRENVILLE A. J. COLE.

THE MODERN MICROSCOPE.

Microscopy: the Construction, Theory, and Use of the Microscope. By E. J. Spitta. Pp. xx+472; 16 plates. (London: J. Murray, 1907.) Price 12s. 6d. net.

MICROSCOPISTS are at present divided into two factions. There are those of the old school, who are content with the principles under the guidance of which such great improvements have been made in microscope construction since the earlier days of Abbe; and there are those whom we may call the "Gordon rioters," who hold that Abbe's experiments were inconclusive and even misleading, and have found a new prophet. The new theory—the adjective has at least some justification—has been duly set forth, with a mint of strange phrases, in Sir A. E. Wright's "Principles of Microscopy," already reviewed in these pages (vol. lxxv., p. 386, February 21, 1907). Mr. Spitta is of the older school. He is for "legitimate methods of observation." He casts an oblique and somewhat mistrustful glance upon the new practices, and hurries by to surer and more familiar ground.

Not so Mr. Conrady, who contributes to the present volume a couple of chapters on the undulatory theory of light, and on Abbe's diffraction theory of the microscope image. Mr. Conrady "has no use" for the new theory, propounded long since by Dr. Altmann, and only of value in that it called forth a complete and overwhelming reply from Abbe in his well-known paper "Über die Grenzen der geometrischen Optik." He urges strongly the adequacy of the diffraction theory to explain all the observed phenomena, and is emphatic as to the inapplicability to the microscope of the theory of the Airy diffusion-disc.

This, however, is not the place to enter on this much-discussed but fascinating topic, with which, indeed, Mr. Spitta's book, from its plan and object, is but little concerned. It is the practical rather than the theoretical to which attention is directed, to the intelligent handling of one of the most finished and delicate of optical instruments.

From this point of view, let us hasten to urge every student of the microscope who wishes to gain a thorough understanding of its principles and possibilities and its defects, and every user of the instrument who desires a work of reference to which he may turn for an explanation of some unexplained optical phenomenon, or for particulars of up-to-date apparatus, to procure a copy of Mr. Spitta's book without delay. It is a leisurely book—an unfriendly critic might even call it diffuse—but there is scarcely a chapter which will not repay careful reading; and when one comes to the chapter on "Testing Objectives," one can but feel grateful to Mr. Spitta for his admirable treatment of a difficult subject.

Mr. Spitta has called his work "Microscopy"; but it is only of one branch of microscopy that he treats. His subject is the theory and use of the microscope as an optical instrument; with the preparation of objects for the microscope he does not deal. The book will be of much interest and of great value to many who are in no sense "microscopists," but who use the microscope as an accessory in other physical investigation. The non-mathematician who desires to know the meaning of the terms "numerical aperture," the "sine-law," "resolving power," or to make himself familiar with the essentials of the Abbe theory, will find Mr. Spitta a satisfactory guide; and the microscopist proper will find innumerable useful suggestions as to the manipulation of his instrument.

It will be well to indicate shortly the ground Mr. Spitta covers. After a preliminary account of the elements of geometrical optics and the theory of the simple microscope, he proceeds to deal with the compound microscope in its modern form, fine adjustments, mechanical stage, substage, objectives—achromatic, semi-apochromatic, and apochromatic; dry and immersion—with details and illustrations of the work of the best makers. In connection with objectives the chief optical properties, spherical and chromatic aberration, the sine-law, &c., are discussed. Then follow chapters on numerical aperture, eyepieces, magnification—in which may be found the main principles of the Abbe theory—the substage condenser, and methods of illumination—critical light, mono-

chromatic light, dark ground illumination, Rheinberg's multiple colour illumination, oblique light, illumination of opaque objects, polarised light. Then we come to "the use of the microscope," with which may be mentioned the valuable hints to workers with which the volume concludes. The binocular microscope and measurements with the microscope are treated, and a long chapter is devoted to the discussion and illustration of microscopes by different makers for various purposes, which is a feature of the book.

Then follows the excellent account of the testing of objectives already referred to. Mr. Spitta confines himself to the use of the Abbe test-plate, and of specified test objects, but within these limits he goes into the matter in detail and with admirable clearness, and this chapter alone is sufficient to justify the work. The section is illustrated in sixteen plates by a beautiful series of photomicrographs. Mr. Conrady's two chapters follow, with another on accessory apparatus. The usefulness of the book is completed by a satisfactory index.

We have said enough to commend Mr. Spitta's volume. It teems with "tips," and is likely to command an even wider popularity than his previous books on allied subjects.

MATHEMATICAL TEXT-BOOKS.

- (1) *Easy Exercises in Algebra for Beginners*. By W. S. Beard. Pp. x+134. (London: Methuen and Co., n.d.) Price 1s. 9d.
 - (2) *Plane Geometry for Secondary Schools*. By C. Davison and C. H. Richards. Pp. viii+411. (Cambridge: University Press, 1907.) Price 4s.
 - (3) *Cartesian Plane Geometry*. Part i. By Charlotte A. Scott. Pp. xiv+428. (London: J. M. Dent and Co., 1907.) Price 3s.
 - (4) *A Sequel to Elementary Geometry*. By J. W. Russell. Pp. viii+204. (Oxford: Clarendon Press, 1907.) Price 6s.
 - (5) *Text-book of Mechanics*. Vol. ii. By L. A. Martin, Jun. Pp. xiv+214. (New York: Wiley and Sons; London: Chapman and Hall, Ltd., 1907.) Price 6s. 6d. net.
 - (6) *Elementary Statics*. By W. P. Borchardt. Pp. viii+308+xx. (London: Rivingtons, 1907.) Price 4s. 6d.
 - (7) *Elementary Trigonometry*. With Answers. By C. Hawkins. Pp. xiii+310. (London: J. M. Dent and Co., 1907.) Price 4s. 6d.
- (1) THIS book is a collection of 3500 examples in elementary algebra up to quadratic equations. It will prove useful to those teachers who dictate the book-work instead of leaving their pupils to read it for themselves. The exercises are well arranged, and there is a good list of contents, so that the reader can at a moment's notice find a dozen or more examples of exactly the type he requires for class use. Answers and examination papers are given, and even though the book does suggest cramming, it has a practical value which will ensure it a welcome. The idea might with advantage be extended to other mathematical subjects.

(2) This book is written for schoolboys who have had a preliminary training in practical geometry, and is devoted almost entirely to theoretical work. The authors are not very fortunate in the first few pages, but when once the reader is fairly started, he will find very little to which he can take exception, provided he is in sympathy with the general arrangement of the book. The authors adopt a conservative point of view, and give a very strong Euclidean flavour to their treatise, but they show themselves capable of appreciating the chief lessons to be learnt from recent experiments in geometrical teaching. Hypothetical constructions are allowed if it can be proved that the construction is possible. The theory of parallels based on Playfair's axiom is deferred until after the principal properties of congruent triangles have been proved. The book covers the substance of Euclid i. to vi.; those of Euclid's theorems which are not included in the text are set as riders together with a large number of well-chosen examples. The treatise is very complete within the limits chosen, and contains sections on loci, geometrical dissections, the nine-point circle, inscribed and escribed circles, Ceva's theorems, &c. A teacher who has conservative views could, on the whole, hardly wish for a better text-book.

(3) The treatise on analytical conics in this series was undertaken by Mr. R. W. H. T. Hudson, and Miss Scott, while pursuing her own plan, has had at her disposal the outline he drew up before his death. The book will prove interesting to the teacher on account of the extreme novelty of the arrangement. The author claims to have shown deference to existing conventions, but it is not so easy to see where self-restraint has been exercised. Apart from the professed innovation of introducing line-coordinates concurrently with point-coordinates from the very first, we have the novelty that the circle is taken as a special case of the ellipse, change of axes is deferred until necessary for the tracing of conics, and so on.

The chief fault of the treatise is probably that the arrangement is far too confused. Properties of the circle are spread over three or four chapters in various parts of the book, interspersed with theorems on conics and straight lines, which theorems are in their turn introduced apparently incidentally, then recapitulated further on, only to be extended in a still later chapter. It seems very doubtful whether a pupil brought up on this method would be able in any way to systematise his knowledge.

Introductory remarks and definitions are apt to be a little obscure, but this is amply compensated by excellent diagrams and very intelligible examples worked at full length. It is a pity that no answers to the exercises are given.

(4) This book is somewhat on the lines of Casey's sequel to Euclid, and covers a good deal of the same ground. It is in many ways an improvement on that standard treatise, and will probably replace it with those students who are just beginning an honours course in mathematics. The chief criticism we have to make is that the contents are of too miscellaneous a character; no one subject is treated quite fully

enough, and the reader is led from one idea to another with almost bewildering rapidity. Perhaps some improvement might have been effected by omitting the chapter on "recent geometry," which contains very little that is new except the nomenclature, and treating more important subjects at greater length.

In a book of this kind the chief danger lies in the insertion of artificial geometrical proofs of theorems best established by analytical or other methods. The author is to be congratulated in having avoided this danger, on the whole, with marked success, though perhaps it would be better to solve Fermat's problem and other examples in chapter xi. by the more instructive methods of chapter xii. The reasoning adopted is of a simple character, and in many cases alternative proofs of equal elegance and simplicity are given. There is a plentiful supply of well-chosen exercises; in many cases concise but useful hints are given in the text for their solution, and a key to the remainder of the examples is promised. The book will prove very inspiring to the beginner, and give pleasure to the more advanced reader.

(5) Mr. Martin's book is intended for readers who have a fair knowledge of differential calculus and are beginning integral, and it covers the more elementary portions of uniplanar dynamics of the particle and rigid body. There is room for such a treatise, but the present one is not entirely satisfactory. Much of it is carelessly worded, e.g. a movement is called the motion of a "point" and of a "particle" in the same section, the definition of a radian is unintelligible, &c. Some of the proofs, as in the case of normal acceleration, are far too cumbersome, while others are hardly rigid—an instance of this is the absence of any mention of D'Alembert's principle or a substitute therefor. The 420 examples will be useful, though no answers are given.

(6) In this treatise an attempt is made to cover the ground very thoroughly; for instance, three distinct proofs are given of the resultant of two parallel forces and the three requisites of a good balance are discussed, while chapters on work and energy, frameworks, virtual work, elasticity, &c., are given. The object aimed at is to include all that part of statics which can be profitably discussed without the use of the calculus. The result is a book which every teacher should possess; it contains all the bookwork he is likely to want and more, while it is a most useful mine of excellent examples. It is more doubtful whether the book is equally suited to class use; it is hardly simple enough for beginners, and the practical experiments are not described in sufficient detail to be of much use for such a purpose. Readers who have Borchardt and Perrott's "Trigonometry" will have a very fair idea of the style and aim of this "Statics."

(7) Mr. Hawkins's book is rather attractive; for a boy who was learning trigonometry in order to become a surveyor it would be ideal. It may be doubted, however, whether the ordinary pupil will take much interest in so many technical details of land-measurement, even granting that practical applications have a fascination for beginners. With a

little judicious skipping, however, the book may be suited to ordinary class use. It is well written, very intelligible, pleasant reading, and mathematically sound (except in § 88). An interesting feature is that the use of the sine and cosecant in solving triangles, finding areas, &c., is explained before the definition of the cosine and secant, and similarly the applications of the cosine are given before the tangent and cotangent are introduced. The contents of chapters ix. and x., with the exception of an isolated section on inscribed and escribed circles, might well be left to a more advanced treatise. The diagrams throughout are excellent. Demoiivre's theorem and similar theoretical developments are not included.

OUR BOOK SHELF.

(1) *Mining Tables*. By Dr. F. H. Hatch and E. J. Vallentine. Pp. viii + 200. (London: Macmillan and Co., Ltd., 1907.) Price 6s. net.

(2) *The Weights and Measures of International Commerce*. Tables and Equivalents. Pp. 59. (London: Macmillan and Co., Ltd., 1907.) Price 2s. 6d. net.

In the former of these works the authors give a comparison of the units of weight, measure, currency, and mining area of different countries, together with tables, constants, and other data useful to mining engineers and surveyors. In the second work, they reprint a selection of tables that appeal to others besides mining engineers. On the whole, the authors have carried out their difficult task in an admirable manner. It is customary for engineers to get together data for use in their professional work, and the reprint of the authors' collection cannot fail to be of service to other workers in the same field. All such collections have, however, their limitations, as the requirements of no two engineers are precisely the same. We miss, for example, information relating to the strength of materials, tables for converting kilograms per square millimetre into tons per square inch, and the like, and in the table of rates of exchange for money, any reference to Spain, Portugal, or the South American republics.

While it is easy to point to omissions, we have not been able to detect any errors in the figures given, notwithstanding a careful comparison, for example, of the tables for the calculation of heights and distances from tachometer readings with the similar tables communicated by Mr. Neil Kennedy to the Institution of Civil Engineers in 1890. In the text, typographical errors are few. There is a little want of uniformity in the spelling of the names of metric weights and measures, grammes and grams, metre and meter, litre and liter being used indiscriminately. Barbados is spelt incorrectly; and Mohs, the inventor of the scale of hardness, appears as Moh. On the title-page, too, Dr. Hatch describes himself as member of the Institute, instead of Institution, of Civil Engineers, and Mr. Vallentine as member of the Federated Institute of Mining Engineers, a society which dropped the term Federated in 1897, and has since been known as the Institution of Mining Engineers.

Les Aciers spéciaux. By L. Revillon. Encyclopédie scientifique des Aides Mémoires. Pp. 188. (Paris: Gauthier-Villars, n.d.) Price 2.50 francs.

To understand even the present state of general knowledge with regard to special steels a very large and difficult field must be traversed, and the task of condensation to a reasonable limit will be a heavy one, but, for those who are unable from various causes to enter the field and would like to know the

kind of work that is being done, this book may be helpful. To compare the results given with one's own ascertained tests of materials made under known conditions would be a considerable task, but a few general matters taken at random are worth noting as examples.

On p. 99 we are told that chrome steels are chiefly made in the crucible, even when large pieces, &c. What can the author think would prevent them being made in the open hearth? They are so made in large quantities. On p. 154, the author permits himself to dream that nickel chrome steels may also be made in the open hearth (they are made extensively) as nickel steels and chrome steels are (which seems to contradict p. 99). P. 118, "Vanadium remains a scientific curiosity . . . excepting for steels of high price such as tool steels." It was a source of great pride to the late Auguste Wiener that he had obtained the recognition of vanadium as an element of practical industrial importance in the manufacture of special structural steels, and Kent-Smith's success in making vanadium chrome and vanadium nickel steels was the main reason why he was taken to America, undoubtedly to carry on similar work.

One regrets to find in a work on this subject, where names are freely used, that the only mention of Prof. Arnold, who has done so much in connection with nickel, vanadium, and chrome steels, is in chapter xv., on nickel vanadium steels:—"There exist also several tests by Prof. Arnold." Perhaps there is some kind of poetic justice in the fact that, to take one example only, the author's readers will not know that a nickel steel given by him at 61 tons per square inch, with an elongation of 3.5 per cent. on 100 mm., when properly made, gives the extraordinary test of about 90 tons per square inch and 10 per cent. elongation on 2". A. McW.

Voice Training in Speech and Song. By H. H. Hulbert. Pp. xii + 83. (London: W. B. Clive, 1907.) Price 1s. 6d.

This book is primarily designed for the use of teachers, who, as the author points out, are probably the greatest voice-users; but it will interest all who speak or sing in public. Voice production is difficult to teach even when the pupil has the advantage of performing exercises under the personal supervision of the instructor, and it may be doubted if much improvement in the use of the organs of speech can be effected by reading text-books alone; but what is possible in the direction of describing suitable exercises appears to have been accomplished with success by the author. The book provides an account of the structure and use of the vocal organs, and the means of securing distinct articulation; it should be useful to all persons who are attending practical classes for the cultivation of the voice.

Revisio Conocephalidarum. By H. Karny. Pp. 114. (Jena: Gustav Fischer, 1907.) Price 4.50 marks.

This compilation dealing with a subfamily of the Locustidae, was published in the *Abhandlungen der k.k. zoologisch-botanischen Gesellschaft* of Vienna, and provides a serviceable continuation of the monograph prepared by Redtenbacher that appeared in the *Behandlungen* of the same society in 1891. Revised analytical tables are given for several of the genera to include recent determinations by the author and other workers. Three genera are here described for the first time—*Paroxyprora*, *Rhytidogyne*, and *Peciloneris*. A considerable number of new species are made, principally additions to the tribe of *Conocephalini*; many were collected in South America, and six were obtained in New Guinea.

LETTERS TO THE EDITOR.

[The Editor does not hold himself responsible for opinions expressed by his correspondents. Neither can he undertake to return, or to correspond with the writers of, rejected manuscripts intended for this or any other part of NATURE. No notice is taken of anonymous communications.]

The Cotton Plant.

ATTENTION has been directed in NATURE of January 16 to a work in which a writer on economic subjects deals with "The Wild and Cultivated Cotton Plants of the World." The subject is as difficult as it is important, and your reviewer, whose expert opinion is held in regard, shows that some of the questions involved may have two sides.

Your reviewer remarks that this work has been doomed to failure owing to the mode of study adopted by its author. If this means that the work is not without error and does not attain finality, the judgment has been anticipated by the author. But if this also means that the work adds nothing to what is known by those who do not happen to be experts in cotton, its readers will find that the verdict cannot be sustained.

The work is compared unfavourably with another on this subject by the late Prof. Todaro. Your reviewer attributes success to Todaro's book because Todaro dealt for the most part with living plants grown by him from seed. It is possibly true that the material studied by Todaro was, for the most part, obtained from the living plants the cultivation of which is related in the introductory fifth part of his monograph. But it is not the case that Todaro's revision of the cottons of the world was based for the most part on this material. Those who have studied Todaro's work know that, of the fifty-four species of *Gossypium* there enumerated, only eleven were certainly described from living plants, although it is possible that others may have been seen by him in the living state. In dealing with the remaining thirty-eight, Todaro has had to rely on the mode of study which your reviewer tells us is doomed to failure; indeed, as regards a considerable number of the species recognised, Todaro has had to depend on the accuracy of descriptions by other writers, because he did not have access to authentic herbarium specimens.

We are, however, less concerned with the work of Todaro than with the continuation and extension of that work which your reviewer says was needed, and which Sir G. Watt has tried to supply. A study of Watt's work shows that its chief merit and value lie in the exhaustive way in which it brings together references to all conceivable sources of information. On this account it will be indispensable to anyone who may hereafter be seriously at work on cotton, who will find it a comprehensive guide to the literature of the subject and to the whereabouts of authentic material. Its readers must follow the rule that applies to the study of subjects so critical, and reserve perfect freedom of judgment as regards the acceptance of Watt's conclusions. They are not bound to agree with Watt as to the provenance or the pedigree of any particular cultivated cotton, nor are they bound to adopt the advice Watt may give as to the kinds most suitable for a particular locality. But when, in deference to other views or on intuitive grounds, we question the validity of Watt's opinion, we are not entitled to do more than reserve our assent unless and until we have critically examined, and if need be supplemented, the material on which that opinion is based.

Believing, as he explains, that the work of Todaro does not require to be corrected, your reviewer is justified in refusing to accept any opinion expressed by Watt which is at variance with that of Todaro, and is free to imagine that, because Watt at times differs from Todaro, Watt's volume is rather a retrogression than an advance on Todaro's work. He is also entitled to assert the right to criticise details as to which he considers himself a competent judge. But his decision that when Watt differs from Todaro therefore Watt must be wrong does not prove this to be the case; his belief in the infallibility of Todaro does not establish that unusual quality; we know, indeed, that at least one of Todaro's species of *Gossypium* does not belong to the genus.

In exercising his right to criticise, your reviewer occasionally raises a doubt whether sound judgment as to the value of a cotton need include full appreciation of the difficulties connected with its botanical status, while his terminology does not make it clear that his conception of botanical characters, and his interpretation of words like "species" and "variety," accord with established usage. This prevents our commenting on his estimate of Watt's system of classification, which is based on those characters that Watt believes to be least subject to variation in truly wild cottons. That among cultivated forms even these characters prove unstable is only too true; but they may still be the best available, and the reviewer does not suggest an alternative method of arrangement.

In certain specific instances your reviewer directs attention to what he terms errors. Thus the treatment by Watt of *G. obtusifolium*, Roxb., and *G. Wightianum*, Tod., is cited as a case of "erroneous synonymy." The situation is this:—Todaro has shown that he only knew of *G. obtusifolium* from Roxburgh's description, and that he did not recognise Roxburgh's species in any of the plants he grew. Todaro has further concluded that a plant which most Indian botanists have treated as a form of *G. herbaceum* does not belong to *G. herbaceum*; this plant he has named *G. Wightianum*. Dealing anew with the subject, Watt has agreed with Todaro in considering *G. Wightianum* distinct from *G. herbaceum*. But Watt also thinks that he can recognise the plant which Roxburgh named *G. obtusifolium*, and believes that *G. Wightianum* is only a variety of *G. obtusifolium*. However the case may stand as to these conclusions, the synonymy they involve is accurate. Even if, as is possible, your reviewer by "erroneous synonymy" only implies that Watt differs from Todaro, the criticism fails. We are unable to say whether, if Todaro had been able to recognise *G. obtusifolium*, any difference of view would have existed. The subordinate questions as to whether Watt's limitation of *G. obtusifolium*, var. *Wightiana*, accords with natural facts, and whether *G. obtusifolium* proper and *G. Nanking*, var. *roji*, should be kept apart or united, are only differences of opinion between Watt and your reviewer on points as to which they are equally entitled to form a judgment.

Your reviewer cites two cases in which he believes that plants have been wrongly identified by Watt. He states that the figure of *G. microcarpum* given by Watt (plate 36) represents a plant other than the one figured by Todaro as *G. microcarpum*. He points out that Todaro describes the two lobes on either side of the central lobe as unequal, and states that the figure given by Watt does not display this peculiarity. On examining the figure of *G. microcarpum* given by Watt, we find that it does show this peculiarity, and on consulting the text we see that it is *G. microcarpum* of Todaro and no other species that is intended to be represented. There may be some mistake with regard to this species; if it be the case that the *G. microcarpum* grown by the reviewer is the true *G. microcarpum* of Todaro, and is at the same time the plant figured by Watt as *G. Schottii*, then the figure which Todaro has given of *G. microcarpum* can hardly represent his own species accurately; it is unlikely that a suggestion as to the identity of *G. Schottii* as figured by Watt (plate 35) and *G. microcarpum* as shown in Todaro's plate will be generally admitted. In the other case, your reviewer's conclusion as to misidentification rests partly on a statement that the name "Piura" indicates a cotton other than the one it connotes in Watt's book, partly on an assertion that Lamarck describes his species *G. vitifolium* as having the underside of its leaves glabrous. The incidence of vernacular names is not always so exact as to justify implicit confidence, but in this instance Spruce, who collected the Piura cotton in Peru and has described it with care, assigns the name to the plant with which Watt associates it. Finally, what Lamarck says with regard to the leaves of his *G. vitifolium* is:—"Elles sont glabres en dessus, un peu velues en dessous."

What we now await is a work on the cultivated cottons from the pen of your reviewer.

D. PRAIN.

Kew, January 20.

The Inheritance of "Acquired" Characters.

I HAVE looked with much interest for some reply from your reviewer to the queries put to him in the letter of Mr. Spicer (January 10, p. 247).

But while he does not attempt to enlighten us, Mr. Archdall Reid, one of the principal exponents of "the infant science of heredity," seeks to show in your columns of January 30 (p. 293) that there is no real basis for this controversy—that Weismann and Herbert Spencer, and all others who have dealt with the question, are alike in error in supposing that there is any real difficulty to be solved.

Mr. Reid seeks to establish his position in this way. He objects to the distinction commonly drawn between "innate" and "acquired" characters; he says these are inaccurate distinctions, and that they have given rise to a long drawn but "futile controversy." He holds the peculiar view that "in man the main difference between the infant and the adult is due to the use acquirements made by the latter during development." Thus, he says:—"Nutriment supplies the material but *not* the stimulus, for *all* growth. Up to birth, the human being, for example, develops wholly, or almost wholly, under this stimulus. Subsequently some of his structures continue to develop under it, for instance, his hair, teeth, external ears, and organs of generation, which grow whether or not they be used. But most of his structures now develop mainly, if not solely, under the stimulus of use, for example, his voluntary muscles, limbs, heart, and brain." But surely the fact that use occurs during the development (and therefore, of course, has some share in promoting the growth) of some parts of the human body must not blind us to the probable fact that the post-natal growth is essentially due to the same inherent causes as pre-natal growth. That being so, is it not absurdly inaccurate to say that "in man the main difference between the infant and the adult is due to use acquirements"?

Then, again, Mr. Archdall Reid seems to assume (in the face of multitudinous difficulties) that the germs of all human beings are potentially alike. He says "innate characters arise inevitably as the child develops, whereas some acquirements are more or less rare. But this is *only* because the stimulus of nutriment is inevitably received, whereas the stimulus of a particular use or injury may not be received. If, however, the latter be received, the acquirement arises just as inevitably as the innate characters."¹

This may, and probably does, hold good for the result of injury and the production of scar tissue, but surely not in regard to the effects of use. No amount of use exercise could make a colour-blind man a good colourist, or enable many persons having, as it is commonly said, "no ear for music" to be good musicians. Thus in some persons what in the majority should be innate qualities are found to be wanting (owing to defects in organisation), while in other persons, wholly independent of any commensurate amount of use exercise, powers like those possessed by a Turner or a Watts, by a Mozart or a Beethoven, or such powers in the direction of mental arithmetic as were found in Bidder, Inaudi, and others. One person has highly developed auditory centres and cerebral regions in association therewith, another has a poor development of the same parts, and the same thing holds good for the visual centres and their associated cerebral mechanisms. Some of those having highly developed auditory centres may prove to have unusual musical abilities, while other persons, like Inaudi, may have marvellous powers in dealing with figures.

It is, in fact, notorious that the stimulus of nutriment and the stimulus of use being present, the results in the way of acquirement will vary *ad infinitum* in accordance with innate differences in individual germs. Yet it is upon the basis of such views as I have quoted that Mr. Reid strives to show that the controversy as to the alleged "transmission" of acquired characters is due to a misunderstanding. "Had the true nature of the distinction between innate and acquired characters been realised," he says, "had it been realised that the difference is one of stimuli, not of innateness or inheritability, and that acquirements are just as much products of evolution as

innate characters, it is impossible that the controversy as to the alleged 'transmission' of the former could have endured so long as it did."

I venture to think that many will not be satisfied with Mr. Archdall Reid's doctrines, and will still consider that the controversy is not closed, as he seems to suppose, but that there is a real problem open to discussion; and certainly those who believe that the effects of use and disuse may be inherited will not find anything in Mr. Reid's letter to show that they are wrong.

In your pages in 1905 (June 15, p. 152) there was a brief communication on this subject from Mr. Woods Smythe which I take to be of considerable importance. He says:—"Lately I heard a missionary at a May meeting tell of the marvellous facility with which Chinese children memorise whole books of the Bible; the four Gospels, and sometimes the Acts also, being an easy feat for children of ten or twelve years. Having carefully sought information from other authorities, I find these facts confirmed, and that the same applies to Mohammedan children. We are aware that for ages their ancestors have been compelled to memorise long portions of their sacred books, and although occasionally we meet with a child of any nation with a gigantic memory, that differs widely from the case of a people where it has become a general characteristic."

Facts of this kind are very difficult, if not impossible, to understand except upon the supposition that use and practice carried on through many generations have led to the begetting of germs having modified developmental tendencies.

How would Mr. Reid explain such facts? In his letter he says:—"Memory, the power of learning, develops under the stimulus of nutriment, but intelligence and reason develop under the stimulus of use." Memory is, therefore, for him one of the so-called "innate" characters which develops independently of the stimulus of use and exercise. For him, therefore, there ought to be no such remarkable memorial powers as those which have been referred to by Mr. Woods Smythe.

H. CHARLTON BASTIAN.

The Athenæum, London, February 3.

The Nature of Röntgen Rays.

IN NATURE of January 23 (p. 270) Prof. Bragg defends his neutral pair theory of X-rays, and his explanation of scattering and polarisation on this theory, against a criticism which I made in a recent letter (NATURE, October 31, 1907). Though he appears to have enlarged his conception of the possible function of the ether pulse in X-ray phenomena, he contends that my one assumption is unjustifiable, consequently is of no value as a critical test. Prof. Bragg had assumed that a pair revolves in a plane containing its direction of translatory motion, that when incident on light atoms it is liable to be taken up only by an atom revolving in the same plane, sometimes to be ejected again, and that if ejected again it continues to rotate in the same plane. My assumption in calculating the distribution of intensity of secondary radiation was that after being taken up by an atom its liability to be ejected again is equal in all directions in that plane. This does not appear quite so unjustifiable as, from Prof. Bragg's letter, one would judge it to have been.

It is evident, however, that this assumption is not a necessary part of the argument against the neutral pair theory, though it appeared, and still appears, to me to be the nearest approximation one can make to the probable behaviour of a pair, if we accept Prof. Bragg's previous assumptions.

But to make calculation possible in place of such a definite distribution we may assume any one of a score of others, as Prof. Bragg does not suggest one. Still, experiments supply what appears to me to be absolutely conclusive evidence in favour of the ether pulse theory. For, after measuring the intensity of secondary radiation proceeding in a direction perpendicular to that of propagation of the primary beam from a substance of low atomic weight during the transmission of "soft" X-rays (conditions producing the most complete polarisation), I have found that the intensity of radiation in a direction opposite

¹ No italics here: in original.

to that of propagation of the primary rays as experimentally determined is within 5 per cent. of that calculated on the ether pulse theory (see *Phil. Mag.*, February, 1908). If Prof. Bragg can suggest a distribution of ejected pairs that will produce such close agreement between the calculated and experimentally determined intensities, it will be time to consider the theory further.

My argument has not been concerned with γ rays, but with the type of radiation with which I am experimentally more familiar—X-rays of ordinary penetrating power.

University of Liverpool. CHARLES G. BARKLA.

The Wave-length of Röntgen Rays.

In his theory of thermodynamical radiation, Planck has found the simple law $e = h_n n = h_n \frac{c}{\lambda}$, where e is an element of energy, $h_n = 6.55 \cdot 10^{-27}$ a constant, n the frequency, λ the wave-length of an electromagnetic resonator, c the velocity of light; according to this "elementary law" the energy of an electromagnetic resonator changes during a period by a multiple of e .

Applying Planck's elementary law on the emission of Röntgen rays by stopped cathode ray particles, I have found the following (*Physik. Zeitschr.*, viii., 882, 1907). Let

$e_k = \frac{m_0 v^2}{2}$ be the kinetic energy of a cathode ray, e its electric charge, V the freely traversed potential difference, the total kinetic energy may be, by stopping, transformed into energy of radiation. The smallest wave-length of the emitted Röntgen radiation is then $\lambda_k = \frac{2h_0 c}{e_k} = \frac{2h_0 c}{eV}$; for a

working potential difference of 60,000 volts on a Röntgen bulb λ_k becomes $6 \cdot 10^{-9}$ cm. Haga and Wind (*Ann. d. Phys.*, x., 305, 1903) have found by their experiments on diffraction for the wave-length of the used Röntgen rays the value $\lambda = 5 \cdot 10^{-9}$ cm.

It is clear that the reversed phenomenon—the transformation of Röntgen rays into kinetic energy of electrons—gives the emission of secondary cathode rays by Röntgen rays, or more generally by light. I have deduced from Planck's elementary law that the maximum of the velocity of secondary cathode rays is independent of the nature and temperature of the radiating body, but inversely proportional to the square root of the absorbed wave-length. This statement is in agreement with the observations of Innes (*Proc. Roy. Soc.*, lxxix., 442, 1907); the observations cannot be explained by the hypothesis of J. J. Thomson and W. Wien that the emission of secondary cathode rays is produced by some radio-active process.

It may be added that Planck's elementary law is also confirmed by my observations on the Doppler effect on Kanalstrahlen; the simple or two-fold minimum of the intensity in this effect is explained by that law (*Physik. Zeitschr.*, viii., 913, 1907). Applying the law to a hypothesis of the origin of banded spectra, it is possible to calculate an inferior limit for the spectral position of the banded spectra of the saturated and "loosed" valencies in chemical compounds (*Physik. Zeitschr.*, ix., 85, 1908).

J. STARK.

The Orientation of the Avebury Circles.

In Sir Norman Lockyer's notes on the orientation of stone avenues printed in *NATURE*, January 10, pp. 249-257, in dealing with Avebury, he finds his argument as to the existence and direction of the Beckhampton avenue upon Stukeley's statement as to the remains of it visible when he wrote in 1724. He then passes to the Kennet avenue, and says:—

"As will be seen from the map, this avenue apparently was connected with the southern circle as the Beckhampton one was with the northern one. If this were so, certainly the enormous bank, erected apparently for spectacular purposes, which is such a striking feature of Avebury, was not made until after the Kennet avenue had fallen out of any astronomical use."

In accordance with this statement, Sir Norman Lockyer marks on the map reproduced to illustrate his notes the course of the south-eastern or Kennet avenue as a straight

line making directly for the centre of the southern circle across the existing bank and ditch well to the left of the present road leading to Kennet. In this he entirely ignores the fact that Stukeley (in the map given by Long, "The Temple at Avebury surveyed by Dr. Stukeley in 1724") marks two prostrate stones of the avenue actually in the existing gap in the earthworks by which the Kennet road enters Avebury, and furthermore notes that they were "broke 1722." Aubrey, too, in his plan taken in 1663 (reproduced in Jackson's "Aubrey," p. 319), shows seven stones of the avenue as lining the sides of the existing road immediately on its leaving the gap in the mound. Lastly, there is standing at this moment a few yards on the right-hand side of the Kennet road a large stone which is the only one now remaining of those seen by Aubrey and Stukeley at the point where the avenue struck the earthwork circle. This stone was apparently not noticed by Sir Norman Lockyer.

Surely if anything can be said to be certain at all about Avebury, it is that the Kennet avenue joined the outer circle through the existing gap in the rampart by which the Kennet road enters it to-day, and did not make straight for the centre of the southern circle over the bank and ditch as shown in Sir Norman Lockyer's plan. Theoretically, perhaps, it ought to have done so, but as a matter of fact, if any weight is to be attached to the statements and plans of Aubrey and of Stukeley, and to the position of the one existing remnant of the avenue on the spot to-day, it did not. In the interests of accuracy it seems desirable to point this out.

ED. H. GODDARD.

Stability in Flight.

MR. MALLOCK (January 30, p. 293) seems to presume, as a great many others do, that an apparatus on the aeroplane principle "demands constant attention on the part of the aeronaut" to maintain its stability in the air. We are apt to get ideas from watching the behaviour of little bits of paper floating in the gusts of wind, and to forget that the flying machine of the future may run into tons of weight. Though a frail canoe may easily capsize, the big ship seldom turns over even in the roughest of seas. Even so primitive a contrivance as we may presume that of Mr. Farman to be is some 33 feet across and weighs, complete, half a ton. Such a structure is not easily upset by mere puffs of wind. But it is also evident that a machine can be designed possessing nearly perfect automatic stability. Langley's model, away from all human control, flew steadily on over the billows of the air for a minute and a half. A well-designed and well-balanced machine is automatically stable without any pendulums or other appliances; in fact, it forms a pendulum of itself.

B. BADEN-POWELL.

32 Princes Gate, S.W., February 1.

REFERRING to the letter which appeared under the above heading in *NATURE* of January 30, I have given some little attention to this subject for the past few years, and thoroughly endorse your correspondent's views.

Any balancing apparatus must be automatic in its action if it is to respond to the changes in the relative motion of the air without delay. It would seem to me that any such apparatus must, as is suggested in the letter referred to, depend on the conservation of angular momentum in a pendulum or fly-wheel. Such a pendulum (or system of pendula) or fly-wheel may operate directly or indirectly, i.e. the torque of resistance opposing change of angular momentum may be employed to right the aeroplane, or may operate mechanism to control the position of guide planes or jockey weights, or rotate the main planes in a suitable manner. The first case is analogous to the Brennan mono-rail system, the second to the Obry torpedo balance.

HERBERT CHATLEY.

32 Britannia Road, S., Southsea, February 1.

The Stresses in Masonry Dams.

I do not think that Prof. Pearson proves his point. Is it not an axiom of practical mathematics that nearly identical functions (within certain limits) may have widely different second differentials? Between σ and π , for

example, a parabola can be found differing but little from $\sin x$. To show that the stresses $\hat{x}\hat{x}$ and $\hat{z}\hat{z}$ are widely different in a plate dam and in a complete dam, it would therefore seem essential to integrate the two equations given by Prof. Pearson in his last letter, and to compare these integrals, or else to decide the matter on other considerations. The integration is, I understand, impracticable, and this being so, the argument in my letter of January 2 would seem to apply. It was to the effect that if in the case of a plate it is permissible to write $\hat{x}\hat{y}=\hat{y}\hat{y}$ throughout, then to the same order of approximation the stresses $\hat{z}\hat{z}$ and $\hat{x}\hat{x}$ are the same in the plate dam and in the actual structure. If the stresses $\hat{x}\hat{y}$ and $\hat{y}\hat{z}$ are zero in the case of the plate, then the stresses $\hat{y}\hat{y}$ which are developed when the lamina forms part of the complete structure cannot, themselves, give rise to any such shears as $\hat{x}\hat{y}$, $\hat{y}\hat{z}$, or $\hat{z}\hat{x}$, and as the dam is not constrained at top or flanks, it is difficult to see how, in the absence of these shears, the stresses $\hat{x}\hat{x}$ and $\hat{z}\hat{z}$ can be affected. Certainly not by the 30 per cent. which Prof. Pearson gives as the order of the error.

83 St. James's Road, Croydon. H. M. MARTIN.

SOME SCIENTIFIC CENTRES.

NO. XII.—THE BOTANICAL INSTITUTE OF THE UNIVERSITY OF BONN.

THE traveller visiting the well-kept Rhenish city of Bonn, on taking a stroll down the beautiful Poppelsdorfer Allee, finds at the end of this delightful avenue a large square building within an enclosure, the Poppelsdorfer Schloss. This building, which is two stories high, enclosing a circular court, bears no external evidence of containing within its walls a great centre of biological research, for the edifice was originally a palace, having been used up to the beginning of the last century as a summer residence of the electors of Cologne. The building is now owned by the university, and is occupied by the biological laboratories and the natural history museum. The rooms of the second floor on the north-east and south-east sides are occupied by the botanical laboratories and by the residence of the professor in charge, one of the greatest botanists of all times, Geheimrath Prof. Edouard Strasburger.

The young botanist who is familiar with the writings of Prof. Strasburger, and has formed some idea of this famous botanical institute, on entering the laboratories for the first time is only surprised and perhaps disappointed, for he sees little that suggests a modern and well-equipped laboratory. The fact that the building was erected in the first half of the eighteenth century, and for another purpose, explains why the rooms are not well adapted for their present use. However, the windows are large, and since there is ample room for apparatus and materials, the investigator has little cause for complaint.

The Botanical Institute includes an elementary laboratory, one for advanced students, a large lecture room, and rooms for assistants and the professor extraordinary. The lecture room is provided with a profusion of charts and diagrams for illustrative purposes. The rooms adjoining the laboratories on the south-east side of the building are occupied by the professor as a residence. Two rooms of his residence Prof. Strasburger devotes to his own work, one serving as a laboratory and the other as a library. In these rooms, which are plainly furnished, everything is orderly arranged and kept scrupulously clean. The library contains, in addition to files of periodicals, all the important works on morphology and cytology. Perhaps the most valuable part of the library is the series of reprints on histological sub-

jects. A copy of almost every cytological paper published, whether treating of animal or plant, is to be found here.

The principal windows of the laboratories and of the residence overlook the palace garden, which has been the botanic garden since the founding of the university. The garden, though small in area, is well stocked and rich in flowering plants. The latter occupy the central part of the grounds, which are carefully laid out and arranged according to the system of Eichler. On either side of the central part is the arboretum, containing many fine specimens of European and some American trees. The arboretum is rich in conifers, one, a cedar of Lebanon, being unusually large and beautiful. A portion of the old palace moat is maintained as a pond for aquatics. The large palm house, the Victoria house, and other greenhouses contain many interesting exotics. The garden has also its special beds of poisonous, economic and medicinal plants, as well as one con-



Prof. E. Strasburger. From a photograph by K. Fujii.

taining plants, widely separated in relationship, but which have solved certain problems of adaptation in the same way. But it is neither the laboratories, the library, nor the botanic garden that has made the institute at Bonn famous; rather the enthusiasm, earnestness and profound resourcefulness of the master mind that directs it.

Prof. Strasburger began his notable series of investigations upon the conifers where Hofmeister left off. In 1872 appeared the large volume with numerous plates upon the morphology and fertilisation of conifers and the Gnetaceæ. This was followed in 1879 by another volume, dealing with the embryology of gymnosperms and angiosperms. His attention having been attracted by the nuclear figures in the endosperm during his earlier studies on gymnosperms, he soon brought to publication a series of observations upon nuclear and cell division. Just thirty-two years ago the nucleus was traced in continuous sequence from

one cell-generation to another, thus establishing for the nucleus beyond all question of doubt the rank of morphological unity. The classic and path-breaking work, "Ueber Zellbildung und Zelltheilung," reached the third edition in 1880, while its author was professor at Jena.

Since going to Bonn, Prof. Strasburger's more important contributions, dealing chiefly with the division of the nucleus and of the cell, with the growth of the cell-wall, the structure of the vascular bundle, and with the process of fecundation, have appeared in five or six volumes, each bearing the principal title "Histologische Beiträge." The bulkiest of these volumes (No. 3), and probably one of the most noteworthy, is on the structure of the vascular bundle ("Ueber Bau und die Verrichtungen der Leitungsbahnen in der Pflanzen"). Apart from several other very important monographs, Prof. Strasburger has prepared the best and one of the most elaborate laboratory manuals and handbooks of microscopic technique known to biological science. "Das botanische Practicum" is now in its fourth edition. "Das kleine botanische Practicum," an abridged edition for the use of more elementary students, was also prepared. A translation of this volume by Hillhouse is still one of the very best botanical handbooks in the English language. With the aid of his former collaborators, the late Prof. A. F. W. Schimper, Prof. Fritz Noll, now of the University of Halle, and Prof. Heinrich Schenck, of the Technical University of Darmstadt, the text-book of botany was prepared, which has gone through several editions and has been translated into several languages.

In more recent years the results of certain important investigations carried on in the institute have been published conjointly by Prof. Strasburger and his students. The most important of these is the volume known as the "Cytologische Studien," which marked the beginning of the more modern phases of cytology. The especial value of this collection of papers consists (1) in the perfection of the best cytological methods known at present for a number of widely differing plants, (2) in the proof that no such structures as centrosomes or centrospheres exist in higher plants, and (3) in the complete establishment of true sexuality in the ascomycetes. Occasionally, Prof. Strasburger carries his private work into fields somewhat removed from the general subject of his life work, though such studies have been comparatively few. In this connection may be mentioned the elaborate study with diocious plants, having for its object to determine, if possible, the effect of environmental conditions upon the control of sex. During the past few years the chief work of the institute has centred about problems relating to the physical basis of heredity, such as the individuality of the chromosomes, the transmission of characters in hybrids, &c.

A glance at the vast amount of literature issued from this most famous centre of cytological research is sufficient to convince one who is not a special student of cytology that the main object and life-work of its director is to understand the meaning of the cell by knowing in the most detailed manner its structure at every step of its activity in all kinds of plants, from the lowest to the highest, and that which has been discovered is only a fair index of what is still to be known.

Probably a summary of the day's programme at the institute will not be without interest to the reader. During the winter semester Prof. Strasburger lectures upon the morphology of the plant groups below the spermatophyta, four lectures being given per week. Once a week, on Fridays, the public lecture is given, which is open to all who wish to attend.

The subject of these public lectures varies from year to year, but it usually pertains to some topic of general interest concerning plants, and is treated from a philosophical standpoint. In the summer semester the lectures deal with the anatomy and physiology of the higher plants. Before going to the lecture room, the professor makes his daily rounds in the advanced laboratories, visiting each investigator, making inquiries concerning the progress made during the past twenty-four or forty-eight hours, and at the same time offering suggestions and criticisms. A visit is frequently made to the laboratory after the lecture or in the afternoon, depending upon the interest in the particular line of study.

Prof. Strasburger's wonderful grasp of the whole field of morphology and physiology, as brought out in frequent discussions in the laboratory, increases daily one's admiration and quickens in one the consciousness of being in the presence of a master mind. When the marvellous results of this centre of scientific research are considered, and the relatively meagre equipment and lack of convenience, the success can only be attributed to the genius of the man who is the centre of its activity and the source of its inspiration. D. M. MORTIER.

EXAMINATION v. RESEARCH.

A UNIVERSITY is as much a place for compromise as a party caucus or a church. It has to provide for different needs and to satisfy conflicting interests. It has to preserve its corporate balance against the attacks of specialists and extremists who try to drag it on to a side-track. And it has to do all these things with limited means and limited wisdom. From time to time doubts may well arise as to how far it succeeds in steering the best course. Oxford at present is in the throes of such a discussion. Always critical, she is more critical of herself than of anything less near and dear, and is now enjoying a perfect orgie of self-criticism. But such emotional delights should not lead to oblivion of the fundamental facts of academic life.

Oxford has to find a working compromise between four distinct functions which lead up to four distinct ideals (or exaggerations) of a university. She has to educate, to teach, to examine, and to research, to say nothing of governing herself, which is not, perhaps, the supreme ideal, as our officials are apt to imagine.

(1) Educationally, Oxford is a place where those who can afford it, or are selected by private or public charity as fit recipients of scholarships, may obtain an intellectual training which will fit them (more or less imperfectly) for a number of professional pursuits, and are subjected to a moral discipline which (again somewhat imperfectly) induces them to do less harm to themselves and to create less disturbance in the community than similarly situated youths are wont to do in any other country. Thus Oxford is not an ideal university. But it is as incapable of being the university of Bohemia as of Utopia. Its educational ideal conducts to the perfect gentleman, or, if it fails, to the perfect snob.

(2) As a teaching institution Oxford is expensive, but (on the whole) efficient. It is expensive because it sacrifices the teacher to the taught, and leads the former to bestow upon the latter a great deal of individual attention, more, possibly, than is good for him, more, certainly, than is necessary or than he gets elsewhere. It is efficient because the college spirit is strong, and the competition between the colleges is keen. Wherever this inducement fails, i.e. wherever the university conducts the instruction or the college takes no pride in it (e.g. in the case of

the "pass" man), the tutor has *not* rendered the "coach" superfluous. Elsewhere the teaching is good of its kind. But since good teaching aims at enabling every fool to appear a genius, it is not an end in itself. The teacher's ideal therefore has to be controlled by a higher, the *examiner's*.

(3) These two functions are quite distinct. The good examiner is not necessarily a good teacher, nor *vice versa*. The excellence of the teacher lies in his ability to instil knowledge and a desire for knowledge; that of the examiner is held to be the exposing of ignorance and pretence. Experience has shown, also, that competitive examinations are among those aids to learning which appeal most forcibly to the national character. They appeal strongly also to the critical faculties of the academic man, and to the love of power in a class which has naturally few occasions for gratifying this instinct. It has been discovered that though knowledge is power, yet the power of testing knowledge confers *superior* power. It is possible to control all knowledge by conducting examinations in it. This, therefore, is what we have set ourselves to do, and the regular genesis of a new branch of study is, first an examination, then students, and last of all the provision of teachers. This is distinctly suggestive of Looking-Glass Land, but to one who has grasped the rationale of examinations it will not be the paradox it seems.

Now it need not be wholly denied that examination has its uses. A certain amount thereof is necessary, and even beneficial to the soul of the examinee, promoting in him a willingness and capacity to absorb and reproduce teaching and to arrange his knowledge which are very conducive to mental efficiency. But the qualities which examination fosters and rewards are not the only qualities of value. Moreover, the benefits to the soul of the examinee are offset by grave dangers to that of his examiner; for the ideal examiner becomes one who is wholly devoted to the exercise of his function, and wholly critical. He can examine everything but produce nothing.

When, therefore, for these and other reasons which it would hardly be decorous to mention, a university sets up an examination system, and gives it power over the whole realm of knowledge, it runs a risk of sacrificing to this idol all its other functions. Teachers and taught alike are sacrificed to it at the annual holocausts, the results of which are contemplated with such reverence that their fame clings to their victims throughout life, and forms an important factor in their subsequent success or failure. Hence it is an ingenious refinement of cruelty when professors of eugenics argue statistically that there is a "high degree of correlation" between success in examination and in life. Does it not follow rather that when a university conceives too great an admiration for its examinational function, it will grow a mental atmosphere which affects the national mind, and is deadly to all its other ideals? The "perfect gentleman" and the devotee of culture (mental or physical) will be forced by the menace of examination into undignified and banal efforts to escape expulsion. The ideal of the perfect researcher will hardly be allowed to germinate; for such a university will have as little use and real regard for researchers as for "pass" men.

(4) Yet the Luptan ideal of an academic life of pure contemplation (or, in a more modern but lowered version, of scientific productiveness), exempt from the sordid duties of disciplining, teaching and examining, is in some ways the prettiest dream of them all. It is a sad pity that ever since the days of Dean Swift mankind has laughed at it. For there is some good in the researcher's ideal, even though

in its extreme form it is absurd. In practice *no* seat of learning can be made up of professors who do not teach, and exist only as objects of distant contemplation by students fearful of perturbing their sacred meditations. Neither the country, nor our purses, nor our sense of humour, would stand it. Besides, it is a psychological fact that a certain amount of teaching is good for research, just as a certain amount of research is good for teaching. The one helps to clarify the worker's exposition, just as the other helps to imbue the teacher with a flavour of originality. Whether a similar connection could be traced between researching and examining seems more disputable.

But there can be no doubt that at present Oxford sets too low a value on research because it sets far too high a value on examination. This sterilises research both by the excessive selection of minds possessing the excellences of the examinee without possessing those of the real student or of the scientific originator, and by the enormous absorption of time and mental energy which our vast masses of examining exact. The wonder is that with such a system we produce anything at all. It is a still greater wonder that, despite contrary assertions based on our habits of self-depreciation, our scientific output, taking it all in all, is not inferior in quality or even in quantity to that of any other academic institution in the world. The explanation lies in the excellence of our recruiting system. We make ourselves so attractive that even the ablest will welcome an opportunity of joining our ranks. And then the perversity of human idiosyncrasy will divert some of this surplus ability into researches which we tolerate without encouraging. For genius, like murder, will out. But with the high average of ability we have in Oxford we could, and should, produce much more, if only more value were put upon productiveness and less store set by criticism.

Enough has been said, perhaps, to give an idea of the root of the evil. But it is not so easy to suggest remedies; for radical measures are Utopian, and ignore the psychological hold which the examination-system has over the national character. But the following suggestions at least seem wholly practicable. (1) In some subjects, *e.g.* natural science (but not, perhaps, in classics, mathematics, and philosophy), the lead just given by the modern historians might be followed, and a research thesis be permitted to form part of the undergraduate's examination. (2) Most of the university prizes, &c., should be awarded to the best researcher rather than to the best examinee. (3) There ought to be a great development of graduate study, and our teachers ought to be enabled, and even required, to acquire a greater initial superiority in knowledge over the taught than is compatible with a system under which most of them are appointed immediately after examination. It will be a red-letter day when an Oxford college elects a research student pure and simple, a mere B.Sc. or B.Litt., to a fellowship. (4) Fellowship examinations of the sort we now have ought to be abolished; for what is the use of deciding over again whether a man possesses the qualities of a good examinee? A college should ascertain rather whether he possesses also the capacity of working at his subject. And, as we saw, he is not the less likely to make a good teacher on this account. From this point of view it is to be hoped that our new Chancellor will give us at least an object-lesson in self-reform by inducing an alteration in the All Souls fellowship examination. (5) The university and the colleges should largely increase the inducements to their members to proceed to "superior degrees" and to undertake the researches which a doctorate ought to imply. At

present only the "new" doctorates of Science and Letters connote any considerable intellectual achievement (though they all mean much spare cash), and so they are manufactured chiefly for export, and hardly half-a-dozen of the existing college tutors (of whom the present writer was unwise enough to become one) have found it desirable to take them.

There are, I know, difficulties of detail in the way even of these moderate suggestions; but even their partial and gradual adoption would abate the fascination of our examination system, and check the tendency to identify the good examinee, functioning as a good examiner, with the ideal of academic man.

F. C. S. SCHILLER.

PROF. C. A. YOUNG.

FEW astronomical books have acquired or have deserved a wider reputation than has been accorded to the "General Astronomy" of Prof. C. A. Young, and all who have profited by the accuracy and completeness of that work will regret to hear of the death of the distinguished author, who identified himself so closely with the progress of the Princeton Observatory (N.J.). Other popular works, such as "The Sun," have been well received, for Prof. Young's qualities as a writer and teacher were well known and acknowledged. But though accident may have given him distinction as a writer of elementary works, of which his long career as a teacher had shown him the necessity, he had far greater claims on our respect and gratitude. Son of a distinguished astronomer, Dr. Ira Young, of Dartmouth, he was early and severely trained in mathematics and astronomy, and for fifty years he gave of his best to forward the interests of the science he loved. Moreover, his activity synchronised with the recent development of physical astronomy; he was one of the pioneers of solar spectroscopy, and his continued and successful researches in various directions entitle him to ample recognition.

His first appointment was to the chair of mathematics in the Western Reserve College, a post from which he retired only to serve his country in a military capacity during the War of Secession. After the war, he succeeded his father as professor of astronomy at Dartmouth College, leaving that post in 1877 to accept a similar position at Princeton, where his energies found sufficient exercise during the remainder of his professional career.

Like most astronomers who have occupied themselves with solar phenomena, Prof. Young found it necessary to follow the track of many eclipses. The most famous of these is that of 1870, when he, for the first time, saw and described the now familiar appearance of the reversed Fraunhofer lines at the instant of the inner contact of the limbs of the sun and moon. Owing to the much-debated "reversing layer," which he suggested as the true cause of the flash, this eclipse has become historical. He took part in the observations of the solar eclipse of 1878 which passed over the American continent, and visited Europe in 1887 for the Russian eclipse, but without result, owing to bad weather. Onwards to 1900 he was a diligent observer of eclipses, and extended our knowledge of the sun's surroundings as well by his acute observation as by his luminous discussion of results obtained. His early explanation of the spectrum of the corona is now received practically as he gave it.

But Prof. Young's researches were not limited to exceptional opportunities. He gave constant and assiduous attention to the solar spectrum at all times, and was an indefatigable observer of the spectrum of

sun-spots, repairing to favourable situations in order to secure good observing conditions. The chromosphere, no less than sun-spots, was the subject of his care, and his catalogue of chromospheric lines, begun so far back as 1872, is a memorable piece of work. Further, he was among the first to determine the velocity of the solar rotation at various heliographic latitudes by measuring the displacement of solar lines due to motion at the source of light. The spectra of planets and comets, of stars and nebulae, were all made the subject of profound study, for his industry was as untiring as his resource was abundant. His work was recognised by the Royal Astronomical Society, which enrolled him among its associates in 1872, and many other learned societies paid him similar honours. He was the recipient of the Janssen medal of the French Academy of Sciences in 1891, but his great reward must have been the consciousness of the amount and variety of work he had accomplished for the promotion of astronomical science.

NOTES.

WE regret to announce that Prof. J. B. Pettigrew, F.R.S., Chandos professor of medicine and anatomy in the University of St. Andrews, died on January 29 in his seventy-third year.

WE observe with great regret the announcement that Mr. W. A. Shenstone, F.R.S., senior science master in Clifton College since 1880, died on Monday, February 3, at fifty-eight years of age.

A REUTER message from Brussels announces the death of M. A. Lancaster, director of the meteorological department of the Royal Observatory of Belgium at Uccle.

PROF. W. RIDGEWAY, professor of archaeology in the University of Cambridge, has been elected president of the Royal Anthropological Institute.

THE French Physical Society has undertaken the publication of a collection of physical constants. The general secretary, M. H. Abraham, has issued an appeal to members of the society to assist in the collaboration.

THE King, who is patron of the Society of Arts, has granted permission to the society to prefix to its title the term "Royal," and the society will consequently in future be known as the "Royal Society of Arts."

ON Tuesday next, February 11, Prof. Stirling will begin a course of six lectures at the Royal Institution on "Membranes: their Structure, Uses, and Products." The Friday evening discourse on February 14 will be delivered by Dr. C. W. Saleeby on "Biology and History," and on February 21 by Sir Oliver Lodge on "The Ether of Space."

SIR PHILIP WATTS, K.C.B., F.R.S., Director of Naval Construction, has been elected a member of the Athenaeum Club under the rule which empowers the annual election by the committee of three persons "of distinguished eminence in science, literature, the arts, or for public services."

THE annual general meeting of the Iron and Steel Institute will be held on Thursday and Friday, May 14 and 15. The annual dinner will be held—under the presidency of Sir Hugh Bell, Bart.—in the Grand Hall of the Hotel Cecil on Thursday, May 14. The autumn meeting will be held in Middlesbrough on September 29 and following days.

In *Engineering* of January 31 there is a sympathetic account of the career of Dr. Coleman Sellers, the eminent American engineer, who died on December 28, 1907, at his residence in Philadelphia in his eighty-first year. He was best known in connection with machine tools, but he will also be remembered for his scheme for utilising the water-power of Niagara Falls, and by his inventions in photography and microscopy.

A CORRESPONDENT asks if the use of wires stretched horizontally at a height of 15 feet or 20 feet in concert halls, churches, and other buildings where the acoustic properties are of the first importance is not based upon erroneous ideas. He expresses the opinion that though the wires are supposed to remedy some fault in the acoustics, they do not produce any useful effect. We are informed that, theoretically, the wires absorb some of the energy and radiate it again in all directions, thus diminishing the amount of regular reflection, constituting echoes, from the walls. But the fraction of the vibrations thus treated is so small that it is difficult to believe the wires have any real, beneficial effect.

MR. H. F. WITHERBY, editor of *British Birds*, informs us that an inquiry is being made into the nature and origin of the disease from which many wood-pigeons have died this winter. The subject is of considerable interest; moreover, possibly the disease, which is very infectious among wood-pigeons themselves, may also be contracted by other birds, and especially game birds. A systematic inquiry into the disease has therefore been undertaken, and schedules of questions have been posted to readers of *British Birds*, the editor of which will be glad to send schedules to anyone who may be in a position to give information on the subject. All the observations will be collated and studied by Dr. C. B. Ticehurst, of Guy's Hospital, who will draw up a full report at a later date.

THE fourth International Congress of Mathematics will be held in Rome on April 6-11. The congress will be divided into four sections. The first section will be concerned with arithmetic, algebra, and analysis, and discussions will be inaugurated by Profs. Arzelà, Capelli, Pascal, and Pincherle. The second section will deal with geometry, and the work will be introduced by Profs. Bianchi and Segre. The third section, covering mechanics, mathematical physics, geodesy, and various applications of mathematics, will be addressed by Profs. Levi-Civita, Luigi, Pizzetti, and Toja. The fourth section will take up philosophical, historical, and didactical questions, and addresses will be given by Profs. Enriques, Loria, and Vailati. Numerous lectures have been arranged, and among these may be mentioned that by Prof. Forsyth, F.R.S., on the present condition of partial differential equations of the second order, as regards formal integration. Other lectures will be delivered by Profs. Darboux, Hilbert, Klein, Lorentz, Mittag-Leffler, Newcomb, Picard, Poincaré, Veronese, and Volterra. Full particulars of the congress can be obtained from the general secretary, Prof. G. Castelnuovo, 5 Piazza S. Pietro in Vincoli, Rome.

REFERRING to the letter by the Rev. John J. Hampson in our issue for January 30 (p. 295) dealing with "stock frost" or ground ice, Mr. D. O. S. Davies, of the Norwich Technical Institute, reminds us of a volume on the subject of "Ice Formation, with Special Reference to Anchor-ice and Frazil," by Prof. H. T. Barnes, of McGill University, Montreal. Prof. Barnes provides information on the points raised by Mr. Hampson in his letter. The book, a descriptive review of which appeared in the issue

of NATURE for January 17, 1907 (vol. LXXV., p. 267), is published in this country by Messrs. Chapman and Hall, Ltd.

THE *South-Eastern Gazette* of January 28 contains an obituary notice of the late Mr. Edward Bartlett, who from 1875 until 1890 occupied the post of curator and librarian of the Maidstone Museum. The deceased naturalist was a son of the late Mr. A. D. Bartlett, the well-known superintendent of the Zoological Society's menagerie in the Regent's Park. In his earlier years Mr. Bartlett travelled as a natural history collector in Upper Amazonia, where he obtained many valuable specimens. Later on, 1863-4, he accompanied the late Canon Tristram to Syria and Palestine, and in 1891 left Maidstone for Sarawak, to act as curator of Raja Brooke's museum, a post which he occupied until 1897, when he returned home. Mr. Bartlett edited his father's well-known work "Wild Animals in Captivity," and was himself the author of several papers on natural history subjects.

No. 13 of the Bulletin of the Imperial Academy of Sciences of St. Petersburg for 1907 contains a paper, unfortunately in Russian, by Mr. D. Dejneka, on the nervous system of the nematode worms.

We have received copies of two papers published by the author at Lancaster, Pa., as Nos. 1 and 2 of a new serial, *Weber's Archives*, in which the author, Veterinary-Surgeon Weber, claims to have bred from the eggs of the ordinary gnat, *Culex pipiens*, two other species of gnats or mosquitoes, in addition to the normal progeny. "Mutation in Mosquitoes" is the title of the second and larger paper. The earlier one, which contains a preliminary account of the same alleged phenomenon, is a reprint of an article published two years ago in *Natur und Haus*, vol. xv., May, 1907.

Two papers on the reproductive organs of sharks have recently appeared within a short time of one another. The first, by Mr. Albert Krall, is published in vol. xxxvii., part iv., of the *Morphologisches Jahrbuch*, and devoted specially to the "claspers" on the pelvic fins of the male of *Hexanchus griseus*, and generally to the corresponding organs in other sharks. In the second, which appears in vol. xxxviii., part iv., of the *Zeitschrift für wissenschaftliche Zoologie*, Dr. Victor Widakowich describes the uterus of the spiny dog-fish (*Squalus acanthias*), with remarks on the developmental history of allied species. The structure of the uterus is described in great detail, and a figure given of a portion of its wall containing an embryo.

CONSIDERABLE interest attaches to an account by Mr. C. H. Danforth, published in vol. xxxiv., No. 1, of the Proceedings of the Boston Society of Natural History, of a new genus and species (*Paedocione doliiformis*) of pteropod mollusc from Casco Bay, Maine. The new form, which was taken in plankton, "does not properly fall under any established family, although perhaps it approaches most nearly the Clionidae, from which it differs in having an odd number of cephalocones and the entire posterior part of the body filled by the viscera." In life the creatures swam for some time by means of their fins, and then sank for a time below the surface, after which the swimming was resumed. With the exception of numerous vacuoles in the integument filled with yellowish or yellowish-brown fluid, the body is transparent.

THE distribution of the pine-marten in England and Wales forms the subject of an article by Mr. H. E. Forrest in the January number of the *Zoologist*. In the midland

and south-eastern counties of England the species, it appears, became rare during the first half of last century, and in most of these it was exterminated before 1860, although isolated occurrences have been recorded since that date in Hertfordshire, Surrey, and Sussex. In Lincoln, Norfolk, and Suffolk it survived until the 'eighties, and there have been recent occurrences in Leicestershire. The Lake District and the west of north and central Wales are, however, at present the sole strongholds of the species. Many of the isolated occurrences appear to be due to the remarkable degree to which the marten wanders.

IN addition to the well-known fishery of the pearl-oyster, Ceylon, it appears from an article by Dr. A. Willey in *Spolia Zeylanica* for November, 1907, possesses a source of pearl in beds of the "window-pane oyster" (*Placuna placenta*) in the backwaters of the eastern province. These beds occur in the backwaters of two neighbouring divisions of the Trincomali district, one of which includes Lake Tamblegam, the headquarters of the Placuna fishes. As the lease of this fishery recently expired, Mr. Willey was sent to the district to report on the best means of improving the product of oysters. These molluscs, it seems, are liable to be destroyed in large numbers by unusually heavy falls of rain such as took place a year ago; nevertheless, the species is in the main a hardy creature, capable of living for several hours out of water, and of surviving for long periods in earthenware vessels if the water be from time to time changed. No mention is made by the author of the annual value of the pearls yielded by the Placuna fishery. The paper includes an account of cysticeroid larvae found parasitic in these oysters.

MR. W. TALEW contributes to the *Bulletin du Jardin Impérial Botanique* (vol. vii., part iii.), St. Petersburg, a paper on the distribution of forests in the district of Starobjelsk, which furnishes evidence that the "steppes" were formerly wooded areas. Mr. A. A. Sapelin discusses the method by which water is absorbed by the sacs in such liverworts as *Frullania*.

LIEUT.-COLONEL F. BAILEY and Mr. R. C. M. Ferguson both contribute articles to the Transactions of the Scottish Arboricultural Society (vol. xx., part i.) on the Interlieven State forest. The purchase by Government of this estate in Argyllshire affords great satisfaction to British foresters but it is hoped that it is only the first step in the policy of acquisition by the State of land for afforestation purposes. The estate, consisting of 12,000 acres, carries very little timber, so that while it affords an opportunity for showing how timber crops can be scientifically grown and for recording data, it will not for many years provide a demonstration forest. It is urged that two wooded areas should be acquired for this purpose, one in the lowlands where hardwoods are cultivated, and one in the highlands stocked with conifers.

It is a debated question whether it is preferable for science students to undertake practical experiments with instruments of their own construction or to make use of apparatus manufactured by instrument makers. Prof. F. W. Ganong, formerly an advocate of the former method in botanical physiology, now declares in favour of instruments of greater precision, and with this purpose has designed several pieces of apparatus that are being manufactured by Messrs. Bausch and Lomb; a descriptive catalogue can be obtained from their agents in London, Messrs. Slatley and Co., Thavies Inn. Among the instruments are a transpiration balance, clinostat, autographic

transpirometer, leaf-area cutter and leaf clasp, but the photosynthometer and respirometer will probably be found the most useful on account of the functions they record.

A BATCH of pamphlets issued from the Royal Botanic Gardens, Ceylon, as Nos. 2 to 5 of vol. iv. of the Circulars and Agricultural Journal, has been received. Mr. E. B. Denham, writing on the use and objects of agricultural societies, attaches much importance to the visits of travelling instructors and to the distribution of leaflets printed in the vernacular; also he suggests that the local societies should make it their business to collect agricultural data. In connection with camphor production, Mr. J. K. Nock has prepared a useful circular on propagation. Practical hints are given for preparing the seed beds and raising the seedlings. If good seed is not obtainable, it is recommended to propagate by means of root cuttings. The chief object of a circular by Mr. T. Petch is to direct attention to a stem disease caused by the ascus-bearing fungus *Massaria theicola*. The hyphae of the fungus fill up the vessels of the wood and cut off the supply of water and salts. The disease can be traced by the discoloration of the wood. A catalogue of plants available for distribution from the gardens has been prepared by the curator, Mr. H. F. Macmillan. The economic list comprises certain spice, rubber, fibre, and drug plants.

WE have received the first number of the *Quarterly Journal of Experimental Physiology*, a new periodical issued under the editorship of Profs. Schafer, Gotch, Halliburton, Sherrington, Starling, and Dr. Waller. The four papers contained in it maintain a high standard; they are:—(1) on the time taken in transmission of reflex impulses in the spinal cord of the frog, by Florence Buchanan; (2) some comparisons between reflex inhibition and reflex excitation, by C. S. Sherrington; (3) the freezing of frog's nerve, with special reference to its fatigability, by John Tait; and (4) on protagon, by R. A. Wilson and W. Cramer. We could have wished that it had been possible to avoid the issue of a new journal, but with so distinguished an editorial committee we presume its appearance is necessary for the advancement of physiological science.

IN the third report to the Gas Engine Research Committee, presented to the Institution of Mechanical Engineers on January 17 by Prof. F. W. Burstall, the results were given of an interesting series of experiments carried out during the past two years on an adapted form of one of the Premier Company's existing types of gas-engine. The engine employed was capable of giving 150 horse-power at a speed of 170 revolutions per minute, the size of the cylinder being 20 inches in diameter with a 24-inch stroke. The diameter of the cylinder was reduced to 16 inches, and an entirely new breech end was constructed with the admission and exhaust valves horizontal. The tests were undertaken to determine the thermal efficiencies based on the indicated horse-power at various compressions, having regard to the richness of the mixture, and to formulate, if possible, the law connecting efficiency and compression. The results of the experiments appear to show that the most economical mean pressure is very considerably below the maximum that can be obtained, and that the highest economies are obtained with a comparatively low maximum temperature. Both these conclusions imply that the engine should not only be subjected to lower pressure, but to lower temperatures as well, and thus many of the difficulties that arise in large engines from rich charges might be avoided, and the maximum pressures kept down to quite

reasonable limits. This applies only to the indicated power; the conclusions as to the brake horse-power would be widely different. If, however, the engine is constructed to work only with these moderate pressures and temperatures, the whole of the working parts might be very much lightened, and a good mechanical efficiency obtained with the very moderate mean pressures.

At the meeting of the Institution of Engineers and Shipbuilders in Scotland on January 21, two papers of considerable interest were presented. In the first Mr. J. J. O'Neill discussed the inter-relation of the theory and practice of shipbuilding, with special reference to the speed-power aspect of the question. He considered that the lengths of the present Atlantic liners warrant the belief that greater power can be obtained, providing that the power their dimensions invite is present. The curves of power also show that the present speeds can be attained on shorter lengths, and that the variations of form involve relatively small gains. The possibilities of the future of the steam turbine, the chief function of which is its capability to obtain greater powers on a given weight than its competitors, widen considerably the vista of engineering practice. With regard to the screw-propeller, the author is inclined to think that, had the same attention been devoted to the screw-propeller problem as has been bestowed on the form of the vessels, greater advantages than the slight variation of form effected would have been secured. In the second paper Mr. I. V. Robinson gave some comparative figures of the cost of power generated by gas and by water. The results show that power generated from blast-furnace gas costs about the same as water-power when the capital cost of the generating station, with or without transmission lines as may be required, is about 18l. per horse-power delivered at the consumers' boundary.

THE new French ethnographical review, *Revue des Études ethnographiques et sociologiques*, under the editorship of M. A. van Gennep, starts its career in the number for last month with an excellent programme. Dr. J. G. Frazer contributes a chapter from the new forthcoming edition of the "Golden Bough" on "St. George and the Pallia." The Pallia is a Roman spring agricultural feast, at which the herdsman used to make a sacrifice to Pales and invoked his protection for the flocks, praying him to grant rain for the pastures and to protect the cattle from wolves. In Esthonia, about the same time of the year, a feast is held in honour of St. George, who grants fertility to women and flocks. In eastern Europe the saint seems to represent the old spring god of the Lithuanians, Pergrubius, and, further east, Tammuz or Adonis. With his wide knowledge of peasant rites and ceremonies, Dr. Frazer has no difficulty in establishing the connection between these varied cults of agricultural and pastoral life. This paper is followed by an elaborate sketch by M. M. Delafosse of the Siena or Senoufo tribe, who inhabit the French territory in West Africa in the region adjoining the British Ashanti frontier. M. C. Boreux discusses the decorated pottery of pre-dynastic Egypt. Some reviews and a bibliography complete a publication which promises to be of considerable value to ethnologists.

THE current issue of the Journal of the Scottish Meteorological Society (No. xxiv., third series) contains memorial notices of Dr. Buchan from several men of science, including Prof. Hann (Vienna), Dr. Shaw and Dr. Mill (London), testifying to the enduring value of his numerous and "epoch-making" investigations. Mr. H. Bell con-

tributes an article on thunderstorms at the Ben Nevis observatories and on the Scottish coasts, on which subject Dr. Buchan was recently engaged. Tabular statements show the cases of occurrence of thunder and lightning from 1884 to 1904, together with their seasonal and diurnal range. The atmospheric conditions which determined the displays were of a very complex character, and are not yet fully understood. The same journal contains (1) an interesting article, by Mr. R. G. K. Lempfert, on the present condition of telegraphic weather services in various countries; especial reference is made to the great importance of recent extensions of area due to the exertions of the Danish and Egyptian Governments. (2) Rain-producing east winds and their influence on the summer of 1907, by Mr. R. Richardson; the author considers that one of the principal causes of the phenomenally bad character of that summer was the frequent sudden shifting of the wind to the east.

MM. P. WEISS and V. Planer give the results of their comparison of the energy losses due to hysteresis in iron, steel, and nickel, in alternating and rotating magnetic fields respectively, in the *Journal de Physique* for January. As previous observers have found, the loss in a rotating exceeds that in an alternating field for comparatively weak fields, but the authors find that for electrolytic iron the loss in the rotating field reaches its maximum when the intensity of magnetisation is about 1200, and decreases to zero at intensity 1700. For steel, the maximum occurs at 1000 and the zero at 1600. For nickel the corresponding numbers are 300 and 500 respectively. The energy losses at the maxima are 17,000, 120,000, and 17,000 ergs per c.c. per cycle respectively.

THE small intensity of the electric waves emitted by a sender consisting of a comparatively short vertical wire, to the top of which a long horizontal wire is attached, in the direction in which the latter points, and the great intensity of the waves sent in the opposite direction, was pointed out by Mr. Marconi in 1906, and in the *Physikalische Zeitschrift* for January 15 Dr. J. Zenneck works out the theory of a receiver of the same form. Such a receiver is most sensitive to waves coming from the direction opposite to that in which the horizontal wire points, for then both the vertical and horizontal components of the electrical field are utilised. The best ratio of vertical and horizontal lengths depends on the ratio of the corresponding components of the wave, and on the conductivity of the soil, but in any case the efficiency of the receiver may be increased by attaching a wire to the base of the vertical wire and extending it on or under the surface of the soil towards the arriving waves.

IN a communication to the Royal Academy of Belgium (Bulletin, 1907, No. 6, p. 684) Prof. Walthère Spring gives an account of his further researches on the nature of the allotropic forms of sulphur. Whilst in a previous paper (see NATURE, vol. lxxv., p. 182) he was able to show that the sulphur obtained on decomposing a solution of hydrogen sulphide with sulphur dioxide is a hydrate, $S_8 \cdot H_2O$, it is now demonstrated that the material precipitated by the action of ferric chloride on a solution of hydrogen sulphide is not hydrated, but is a new allotropic form of the element. The new variety has a density which is sensibly the same as that of orthorhombic sulphur, and like the latter dissolves in carbon bisulphide, but it differs from it and from all other known forms of the element in its specific heat. Precisely the same form, giving identical values for the density and specific heat, is also obtained on decomposing an alkaline polysulphide in solution by means of an acid.

In a note published in the *Atti dei Lincei* (vol. xxvi., 2, p. 717) under the title "The Origin of Stereo-chemistry," Prof. E. Paternò points out that in 1869, five years prior to the publication by Le Bel and van 't Hoff of the doctrine of the asymmetric carbon atom, he suggested that if three isomeric forms of the compound $C_2H_2Br_2$ actually existed, the fact could be explained by assuming the four affinities of the carbon atom to be directed towards the corners of a tetrahedron. This was the first occasion on which the hypothesis of the tetrahedral configuration of the carbon atom was definitely formulated. Although the validity of Prof. Paternò's claim has already been admitted in some quarters, it is not generally known to chemists that the conception of a tetrahedral carbon atom, the basis of modern stereo-chemistry, had been proposed earlier than the year 1874, when it was brought forward simultaneously by Le Bel and van 't Hoff.

THE whole of the mathematical and physical library of the late Prof. A. S. Herschel, F.R.S., and also works from the library of the late Mr. F. Moore, author of books on the Lepidoptera of India and Ceylon, are included in a catalogue just issued by Mr. T. Thorp, Guildford, Surrey, who offers the books for sale.

AN enlargement by four diameters of a photograph of the moon taken by Mr. W. Rice with a Goerz telephoto lens, the exposure being three-fifths of a second, has been sent to us by Messrs. G. Philip and Son, Ltd. The photograph was taken twelve hours before the moon was full, and though the enlargement, which is 6 inches in diameter, is not remarkable for any details it shows of lunar features, it gives a real impression of our satellite as a ball in space, this appearance of relief being accentuated by the bright streaks radiating from the crater Tycho near the south lunar pole.

AT the anniversary dinner of the Royal Society on November 30 last, Lord Dunedin bewailed the fact that few men of science make any attempt to describe their investigations in language which can be understood by men of culture without special scientific knowledge. This speech, as was pointed out in *NATURE* (vol. lxxvii., p. 111), gave rise to a correspondence in the *Times*, in which the advantage of increasing interest in scientific work by making the results as widely known as possible was insisted upon in many quarters. A similar necessity has been recognised in America, and an attempt is being made at Columbia University to provide literature of the kind required. The Columbia University Press has arranged to publish in the form of pamphlets a series of twenty-two descriptive lectures in non-technical language of the achievements of science and modern scholarship. We have received copies of the first two pamphlets; the first, on mathematics, is by Prof. C. J. Keyser, and the second, on physics, by Prof. E. F. Nichols. A doubt may be expressed as to whether the language of these lectures will be simple enough for the public for whom they are intended. The pamphlets partake largely of the character of the Royal Institution lectures, reprints of which are often available in this country, and contain terms and ideas which, though simple enough to the reader with some training in science, present difficulty to the student whose education has been chiefly on literary lines. It will be interesting to learn later the extent of the encouragement received by the Columbia University Press. The price of the pamphlets is in every case to be 25 cents.

NO. 1907, VOL. 77]

OUR ASTRONOMICAL COLUMN.

THE DISTORTION OF PHOTOGRAPHIC FILMS IN STELLAR WORK.—In No. 1, vol. 3, of the Publications of the Allegheny Observatory (Pennsylvania), Dr. Frank Schlesinger discusses the possibilities of error introduced into photographic star-measures by reason of the distortion undergone by the film during the process of development. He further describes some experiments and measures he has made in order to determine the magnitude of this error. By developing, drying, and measuring a negative in the ordinary way, and afterwards putting it through the developing, fixing, washing, drying, and measuring processes again, he has obtained the data from which he draws his conclusions. Briefly, he finds that this error is much smaller than the error of bisection for good star images, being of the order of one one-thousandth of a millimetre for the kind of plate employed.

TWO HUNDRED NEW DOUBLE STARS.—Lick Observatory Bulletin No. 125 contains a list, and measures, of 200 double stars discovered by Prof. Aitken. This is the eleventh list of its kind, and the stars now announced bring the total of Prof. Aitken's published discoveries up to 1700. Nine fainter companions to previously known pairs are included in the present list, which also contains measures of the unusually bright and close pairs κ Ursæ Majoris and ν^2 Bootis (Aitken, 1585 and 1634) as follows:—

	Date	Angle	Distance	Mag.	Annual proper motion
κ Ursæ Majoris ...	1907'83 ...	283°'2 ...	0''·421 ...	4'·-4'2 ...	0''·079 in 211''·1
ν^2 Bootis ...	1907'55 ...	237°'0 ...	0''·003 ...	5'5'·5'3 ...	0''·04 in 246''

A NEW ASTRONOMICAL JOURNAL.—The members of the progressive astronomical society of Antwerp having expressed a desire for a publication which would give the various ephemerides, and a simple account of the astronomical phenomena to be observed from time to time, the council of the society has commenced the publication of the *Gazette astronomique*, which is to appear monthly, and is designed to fill the gap indicated; popular articles on astronomical subjects are also to appear. No. 1 (January 4) contains various ephemerides, notes on phenomena occurring during January, accounts of the recent transit of Mercury, and a series of notes dealing, respectively, with the planets, asteroids, meteors, comets, &c. The annual subscription for this useful publication is three francs, post free in all countries, and all communications should be addressed to "Gazette astronomique," Chaussée de Turnhout, 342, Borgerhout, Antwerp, Belgium.

THE STUDY OF METEOR TRAINS.—The *Monthly Weather Review* (U.S.A.), vol. xxxv., No. 9, contains a suggestive article by Prof. Trowbridge on the utility of the precise observations of meteor-train drifts for the determination of atmospheric currents at altitudes otherwise inaccessible. This altitude, of meteor trains seen at night, ranges from forty-five to sixty-five miles, and Prof. Trowbridge believes that the conditions of pressure and temperature at about fifty-five miles above the earth's surface are possibly peculiarly suitable for the production of trains; careful study may enlighten us as to these conditions. Several recorded trains are illustrated in the article and fully discussed, and the author suggests that valuable results may follow from an organised series of careful observations.

THE ACCURACY OF DOUBLE-STAR MEASURES.—A paper by Prof. Doberck, appearing in No. 429 of the *Astronomische Nachrichten* (p. 65, January 21), should appeal to double-star observers. In it the author gives the probable constant errors, and the residuals after applying these constant, or the mean, errors to the observations, in position-angle and distance for some fifty past and present observers. The probable errors are based on the comparison of the results of the various observations with the positions calculated from the orbits of thirty double stars recently determined by Prof. Doberck. The effects of difference of colour, which, as Prof. Doberck remarks, must be considerable, are not discussed in the present paper, but the same worker expects to deal with them later. The variations of the probable errors caused by increase of the distance between the components, and by

greater differences of magnitude, are well shown in some of the results, although in other cases magnitude appears to have made no difference. Thus Admiral Smyth's results show a probable error in angle of $\pm 0^{\circ}.031$ below 3° and $\pm 0^{\circ}.049$ above 3° , but it is not certain whether the magnitudes have any influence; there is no evidence of systematic error in the distances, but an average constant error of $\pm 0^{\circ}.073$ is indicated. Prof. Dobereck states that these observations are of very great value. In the case of H. Struve the magnitude coefficient is probably considerable.

FORTY-ONE NEW VARIABLE STARS.—Circulars No. 134 and No. 135 of the Harvard College Observatory announce the discovery of forty-one variable stars. Of the sixteen announced in the former, two show remarkably large variations. One of these, D.M.— $30^{\circ}.2883$, situated in Columba, decreases from magnitude 10.4 to below magnitude 15.0, whilst the other, D.M.— $46^{\circ}.14688$, situated in Phoenix, ranges from 8.5 to less than the twelfth magnitude. The variations of a number of stars announced in Circular No. 129 have been confirmed visually, and of these TT Aquilæ is especially interesting on account of its brightness and probable colour changes. The second circular gives particulars of twenty-five newly discovered variables found in regions Nos. 24, 36, and 42 of the Harvard map. In this research the number of variables found to be of the Algol type has been a remarkable feature, and of the twenty-five now published, eight are probably of this, or of the β Lyrae, class. The large number of variables found in map 42 appears to be significant, and should be taken into account in any discussion of the region, which includes a large portion of the constellation Scorpio and the nebulous region in Ophiuchus.

AMERICAN ETHNOLOGY.

THE American Bureau of Ethnology, with its usual energy, has lost no time in extending its operations over the new colonial possessions, the Philippines, and some West Indian islands. The most important contribution to the twenty-fifth volume of its reports, for 1900-7, is an account of a preliminary survey of Porto Rico and the neighbouring islands, conducted by Dr. J. W. Fawkes.

Porto Rico, the smallest of the Greater Antilles, is naturally linked with Venezuela by the chain of the Lesser Antilles, which stretch southwards to the mouth of the Orinoco. It lies within a region of volcanic disturbance, and it is possible that when it was first occupied by man it may have formed part of an isthmus connected with the South American coast. A temperate climate and a productive soil naturally invited colonisation. The fauna and flora are of the South American type, and many considerations support the conclusion that Porto Rico and the adjoining islands were peopled from the valley of the Orinoco. Thus the houses of the people of both these regions are similar in type, and we find no traces of stone buildings which would naturally have been erected by emigrants from the Maya or other Yucatan tribes. The use of cassava, a South American product, and the care which the primitive inhabitants of Porto Rico, like those of the Orinoco, devoted to the preservation of the skeletons of their dead, are facts pointing in the same direction.

Except in the interior of the island, few traces of the aborigines survive. The inhabitants were massacred by the Spaniards, who re-peopled the island with slaves from the Bahamas and negroes from Africa. From the intercourse of these people with their rulers a half-caste population sprang up. Thus the island at present is occupied by a mixed race, and the absence of a collection of the skulls of the aborigines renders it difficult to decide what their race character may have been. The accounts of their physique and character given by the early Spanish writers do not, however, conflict with the theory of their South American origin.

The relics of this forgotten race are to be found in the dancing plazas, shell-mounds, and caves scattered over the island. The character of their stone carvings and pottery indicates that they had reached a high grade of culture. The plazas were stone enclosures in which ceremonial

dances were performed with the object of securing abundant rain and plentiful harvests, success in war, the cure of the sick, for commemoration rites of the dead, initiation and other ceremonies. They often contain

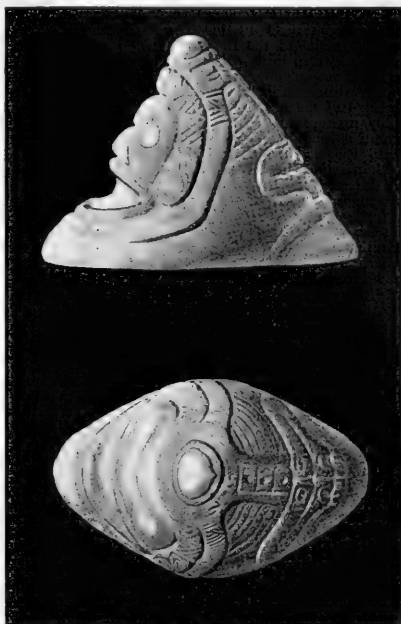

FIG. 1.—Lateral and top views of a three-pointed stone of the second type (Latimer collection); length 3 inches.

water-worn stones, which Dr. Fawkes supposes to have been emblematic of flowing water, and to have been used in some form of mimetic magic to control the rain. Their religion was of the animistic and shamanistic type, and its ritual largely consisted in the worship of *Zemis*, a term which included their gods, symbols of deities, idols, bones, skulls of the dead—in short, anything supposed to possess magical power.

The most remarkable idols were those of the "three-pointed" anthropomorphic type (Fig. 1). The interpretation of these objects is obscure, and many theories of their origin have been suggested. Dr. Fawkes regards them as clan idols or tutelary totems, the difference in their form denoting different conceptions of the *Zemi* in the various clans. Equally curious are the zoomorphic or anthropomorphic pestles (Fig. 2), which were employed with mortars in the preparation of food, and the stone collars, which, according to one theory, were used in association with the "three-pointed" images, and with them formed a snake idol. This explanation Dr. Fawkes rejects; but, except that they must have been used for some religious or ceremonial purpose, their meaning is still uncertain.



FIG. 2.—Bird-shaped pestle from Sa.to Domingo.

The rude pictographs or petroglyphs found in the island are equally remarkable. Some of the best specimens are engraved on boulders in rivers or in their vicinity, thus possibly indicating their use in some mimetic rain ceremony. Others, drawn with less care, differing from the river sculptures in size, shape, and apparently in significance, are inscribed in the caves so common in the calcareous rocks of the island. They represent in some cases a head furnished with horns, human faces, and rude representations analogous in type to the "three-pointed" images, with circles, spirals, and other symbols. Our knowledge of the aboriginal cults is at present too scanty for any attempt to explain their significance. That they represent objects of religious worship seems fairly certain.

Porto Rico is thus a most promising field for archaeological investigation. The report of Dr. Fewkes suggests many interesting problems. It is well written, and, like other publications in the same series, is admirably illustrated.

Another article by the same writer describes a tour of exploration in eastern Mexico, undertaken with the object of ascertaining the relationship between the mound builders of the lower Mississippi and the people of the Mexican coast known as Totonac and Huastec. The Totonac metropolis, Cempoalan, was for the first time examined. From this investigation it seems probable that the mound builders of the southern States were more closely connected with the races of eastern Mexico than with those of the arid region of the south-west or even with the plateau tribes of eastern Mexico.

The third part of the thirteenth volume of the Journal of the Academy of Natural Sciences, Philadelphia, is devoted to a fresh exploration of Moundville, Alabama, and sites on the Crystal, Chattahoochee, and Lower Flint Rivers, and the Ten Thousand Islands of Florida, by Mr. C. B. Moore. The appearance of the Swastika symbol and other objects discovered at Moundville seems to indicate that this was an important religious centre, specially devoted to the worship of the sun, conducted in temples by an order of priests, who kept the sacred fire continually burning as an emblem of the luminary. The discovery at the Crystal River of an ear-ornament overlaid or covered with meteoric iron is an interesting proof of the skill of this race in metallurgy, and it seems to connect the races of Florida, who buried their dead in mounds, with the people of the Ohio valley region. This report also is provided with excellent illustrations of the remarkable series of finds which were secured by Mr. Moore's expedition.

THE NITROGEN PROBLEM IN AGRICULTURE.¹

FOR many years what is known in agriculture as the nitrogen problem has received considerable attention both from men of science and from practical men. It has two aspects. Few soils contain nitrogen compounds in sufficient quantity for the needs of non-leguminous crops, and the application of nitrogenous manures is one of the commonest, as well as one of the more costly, operations of modern agriculture. On the other hand, leguminous crops not only need no nitrogenous manure for themselves, but actually increase the store of nitrogen compounds in the soil, and dispense with the necessity of adding more for the succeeding crop. The problem would obviously vanish if leguminous crops could be grown every other year, but unfortunately they are liable to "sickness," and can only be grown once in four or even six years. Even as it is, however, any method that increases the nitrogen-fixing power of a leguminous crop is a welcome addition to the resources of a farmer.

In 1886 Hellriegel and Wilfarth showed that nitrogen-fixation is the work of certain micro-organisms associated with the leguminosae. It has since been shown that they can grow apart from the plant, and can be inoculated into soils, and also that an increased crop may follow such inoculation.

On three occasions cultures of these organisms have

¹ "Seed and Soil Inoculation for Leguminous Crops." By Prof. W. B. Bottomley. (London: Country Life Office.)

been widely distributed among farmers. In 1896 Nobbe sent out "nitragin"; in 1903 Moore's cultures were issued in America; and now we have Prof. Bottomley's cultures. Each time very great and widespread interest has been aroused, the matter has been discussed at length in the daily Press, and has even on occasion formed the subject of questions in the House of Commons. The subject appeals to almost everyone. Few scientific problems are more interesting than the wholly unparalleled synthesis of complex organic compounds from free nitrogen and other simple bodies effected by these micro-organisms at the low temperatures of the soil. The practical man sees in inoculation the possibility of increased leguminous crops and of less expenditure on nitrogenous manure for his other crops. The man in the street, who has always been ready to take an interest in nitrogen since Sir William Crookes's British Association address at Bristol in 1898, sees the threatened nitrogen famine averted and his food supply rendered secure for a long time to come.

Inoculation has proved very successful on virgin soils, or in dealing with new leguminous crops, but there is little or no evidence that it is effective when the soil is already in cultivation and the crop no longer new. Nobbe's cultures failed, and Moore's cultures were not particularly successful when applied in ordinary farm practice. Certain other less boomed cultures, e.g. Hiltner's, have done better, and have sometimes given 20 per cent. or 30 per cent. increases in crop. Prof. Bottomley tested his culture by distributing more than a thousand specimens; 80 per cent. of the reports received (unfortunately we are not told the actual number) showed an increase in crop. The pamphlet before us consists largely of extracts from these reports.

Experiments of this nature are very difficult to carry out. Great care is necessary in selecting the ground, proper control plots are needed, and the experiment must be continued for several years without essential modification. Under favourable conditions, the error of a field experiment lasting many years may be as low as 5 per cent., but for shorter periods it is much higher. We cannot find any evidence that these facts have been taken into account; on the contrary, most of the trials have obviously been made by novices. Only in a few cases have any weights been taken, and the results have usually been guessed. Here is an "experiment" with peas:—

"I planted the inoculated peas on land that had not been manured for many years, and had a crop of peas quite equal to those grown by a friend on manured soil" (p. 24).

Another:—"Gradus" without inoculation, a fair crop, but they were soon over."

"Sutton's A 1" inoculated, heavy crop, with abundance of well-filled pods" (p. 21).

Again:—"First sown peas, inoculated, a fine crop.

... Second sowing, uninoculated, results very poor. . . . The ground on which first crop was sown had had no peas on it for several years, whereas the ground on which second crop was sown had had peas grown on it in the previous year" (p. 17).

It is scarcely necessary to say that statements of this kind are of no scientific value.

Fifty-two reports are quoted; fifteen must certainly be rejected, eighteen give no figures, thirteen give estimated figures, and six give weights. Confining our attention to the nineteen cases where figures are given, we find that in four the increased yield is 20 per cent. or less; this cannot be much greater than the magnitude of the experimental error. In nine cases the estimated increase is 30 per cent. to 50 per cent., and in five cases more than 50 per cent. A detailed discussion is obviously impossible; we can only point out that a few experiments properly made on sound lines would have been very much better than all these testimonials. So far as they prove anything at all, however, they go to show that the author has, like Hiltner in Germany, Moore in the United States, and Golding here, obtained cultures which may in suitable cases increase the yield of leguminous crops, and the increase seems to be estimated in the majority of cases at about 30 per cent. to 50 per cent.

Now if it turns out to be correct it will be a very useful result, but in ordinary farming it can only be

looked for once every fourth or sixth year, for it is not claimed that inoculation cures "sickness" and increases the frequency with which leguminous crops can be grown. Even a 50 per cent. increase in crop, useful though it would be, would in these circumstances hardly effect any particular revolution in agricultural practice. We are therefore unable to follow the author when he remarks—"For a few thousand pounds the 21 million acres of poor barren land in this country could be made productive and rendered capable of finding work for and supporting such a population that both the food problem and the unemployed problem would be easy of solution. . . . Waste land reclaimed and made fertile for 6d. an acre! . . ." It would have been better if the author had induced an agricultural friend to revise this estimate. We are told on pp. 8 and 10 that inoculation will be a failure when the soil is too acid and in need of lime, when it is deficient in phosphates and potash, when the physical conditions of the soil are unfavourable, or when drainage is needed. Barren land in England commonly suffers from several or all of these defects. How far would sixpence an acre go in putting them right?

At a time when the farmer needs, and is willing to accept, all the assistance the scientific investigator can give him, the fact that an enthusiastic worker like Prof. Bottomley has directed his attention to agricultural botany is a matter for congratulation, and we can only regret that in this, his first appeal to the practical man, his enthusiasm should have outrun his judgment. However, although we must regard the present production as unsatisfactory, we still look forward to sound work from the author on this subject, and we wish him success in his work on the numerous and difficult problems connected with soil inoculation. E. J. R.

MATHEMATICAL EDUCATION AND RESEARCH.

THE annual meeting of the Mathematical Association was held at King's College, London, on Saturday, January 25. The proceedings bear abundant testimony to the great changes which are taking place in the methods of teaching mathematics, and show that these changes are not confined to the subject of elementary geometry. Mr. W. J. Dobbs showed what useful work could be done by means of simple home-made apparatus in the teaching of mechanics, his apparatus consisting merely of spiral springs with cardboard scales attached for illustrating applications of the parallelogram law, and suspended sticks for illustrating the principle of the lever and the balance. He further showed how the solution of problems on accelerated motion could be greatly simplified by the application of direct methods not involving such restrictions as to units as are necessary in working with "poundals" or "slugs." Mr. C. O. Tuckey made a distinct step in advance in his suggestions as to the methods of introducing the properties of convergent series to students who require these series principally in the study of the calculus, and it is interesting to compare his views with those which prevailed twenty or thirty years ago, when the calculus was regarded as something sacred which should not be handled by students until they had passed through a lengthy period of probation in working with algebraic series. Mr. F. J. W. Whipple's lantern-slides, showing how the convergency of certain trigonometric series could be illustrated by diagrams drawn by mere beginners, were a revelation to those who had approached the subject by the study of pages of long formulae. Mr. W. E. Bryan suggested a very original way of introducing similar figures in geometry, a method which, however, may well form a basis of further discussion and criticism. An apparatus for drawing rectangular hyperbolas was shown by Mr. H. L. Trachtenberg.

In his presidential address Prof. G. H. Bryan, F.R.S., dealt with the uses of mathematics and the training of mathematical teachers. It was necessary that the public should be made aware of the important part which higher mathematical research had played, and was destined to play, in practical applications on which the prosperity of

a nation depended. As an instance, Prof. Bryan referred to the seemingly unpractical and uninteresting study of the properties of imaginary quantities, without which modern applications of electricity to purposes of commerce, including wireless telegraphy, could never have reached their present developments. In order to overcome the existing lack of public interest in mathematical matters it was important that the university training of every mathematical teacher should afford him some insight into the research aspect of some one branch of the subject, and the experiments that had already been made in this direction in the university colleges of Wales showed that this ideal was quite capable of attainment. Turning to the teaching of mathematics in elementary schools, Prof. Bryan expressed the opinion that the children of the working man should learn to measure and calculate correctly in order that they might become more efficient and improve their positions in the labour market. If their teaching was conducted in such a way as merely to stimulate in them a spirit of luxury and discontent as distinct from a desire for self-improvement, the working classes had quite as much cause for complaint as the tax-payers. But in the training of elementary teachers, antiquated and unpractical methods are still prevalent, and are often greatly encouraged by examination requirements.

RADIOGRAPHY IN PEARL FISHING.

THE products of the sea are commonly wasted to a very deplorable degree by those who gather and use them. In no instance is this waste more marked than in the search for pearls. By the old method, which is still in vogue as a general rule, an enormous number of the so-called oysters are taken from their habitat and destroyed without any thought of economy. It is said that only one pearl is found in 100 oysters, and only 1 per cent. of the pearls found are of any commercial value. Thus some 10,000 of the precious molluscs are sacrificed for every useful pearl obtained. Among these victims there must be a vast amount of immature pearls or seed, pearls *in posse*, which might grow and become valuable gems, which are deprived of that possibility by premature destruction.

In the year 1901 Prof. Raphaël Dubois took radiographs of pearls *in situ* within the shell of *Unio prolifera*, and obtained a clear view of their size and situation in spite of the thickness of the shell in which they were encased. He showed these radiographs at the Linnean Society of Lyons, and remarked that the X-rays might receive a novel application if used in the fisheries of Ceylon, and the destruction of a vast number of the prized molluscs might thus be avoided.

The difficulty of applying the X-rays to many thousands of shells *per diem* seemed sufficient to deter the ordinary person from such a laborious attempt. However, a few years later an electrical engineer of New York, Mr. John J. Solomon, who took an interest in the question of pearls, was struck by the same idea of using the X-rays to detect the existence of pearls within the shell of the living animal. He was then unaware of the earlier experiments of Prof. Dubois, but promptly set himself about the work from a commercial point of view.

He found that an exposure necessary to obtain a good picture did not in any way injure the animal, and even an exposure of ten times as long could be applied without causing its death from the effect of the rays. The dangers lay rather in the removal of the bivalve from its normal attachment and in the time required for its transit from its bed to the laboratory of the photographer: for the pearl oyster is really a kind of mussel, which holds on to some fixed object by a brush of fibrils (*bysus*) growing from its body.

Thus the fundamental principle of Prof. Dubois, to save the life of unremunerative bivalves, bids fair to be carried out by American ingenuity and capital.

For practical purposes, where many thousands of shells have to be radiographed daily, a completely novel kind of plant had to be devised. This was done, and final success was considered to be well in view, when 100 clear radiographs could be taken on an average every fifteen seconds.

Mr. Solomon often succeeded in taking as many as 500 per minute. In this process some hundred shells are exposed at a time to the rays. The oysters, spread on trays, are carried under the specially constructed cylinders by means of an electric motor. These great cylinders are cooled by means of suitable water jackets, and can thus be kept working continuously.

The oysters in which there is no sign of pearl formation are put back to their beds. Those in which good-sized pearls are detected are removed and opened, and the pearls promptly utilised. Those showing no pearls of adequate commercial value, but containing promising seed or immature pearls, are carefully placed in hospital. This hospital has rather a novel object; not the cure of the pearl disease (for the much prized gem is but a pathological growth), but, on the contrary, everything is done to keep the mollusc in *stutu quo ante* so that the disease may progress as rapidly as possible to the production of valuable pearls and to the death of the incurable patient.

The question seems to arise, can the normal, or perhaps we should say the abnormal, conditions of the pearl-producing bivalve be well enough imitated in captivity to ensure the continued growth of the pearls? May not the "change of water" (as they must be kept nearer the surface) secure for the sufferers immunity from their diseased process? One might have imagined that a greater amount of sunlight, more oxygen, altered temperature, different nutrition, lessened pressure, and other changed conditions we think not of, would so influence the life of the mollusc that it might depart from its pathological but useful habit of producing these valued round bits of shell material, and the hospital might thus prove a true *Kur-Instalt* instead of a pearl-breeding depot. But Mr. Solomon tested these points, and he has satisfied himself that, if he can be certain to transmit in all circumstances the oysters to and from his laboratory without injury to their well-being, all other difficulties have already been overcome. As to the lucrative commercial value of the undertaking, time alone can tell; sufficient has not yet elapsed to make it demonstrable by actual proof that pearls can thus be hatched *en gros*.

UNIVERSITY AND EDUCATIONAL INTELLIGENCE.

CAMBRIDGE.—Two Graces will be offered to the Senate at the Congregation on Thursday, February 13; the first gratefully accepts the generous offer of the Drapers' Company to contribute a sum of 200*l.* a year until 1910 towards the stipend of a second professorship in the department of agriculture, and the second establishes in the University a professorship of agricultural botany.

The council of the Senate has reported that it is of opinion that the University should hold a Darwin celebration in the course of the year 1909. The council points out that Charles Darwin was born on February 12, 1809, and that the "Origin of Species" was published on November 24, 1859. The hundredth anniversary of the former event, and the fiftieth anniversary of the latter, will therefore fall in the course of the year 1909. It is suggested that representatives of universities and other learned bodies, together with distinguished individuals, should receive invitations to visit the University on the occasion. Should this report be confirmed by the Senate, the council will appoint a committee to consider the details of the proposed celebration. The week beginning June 20, 1909, appears to the council to be the most suitable time for the celebration.

LONDON.—The degree of D.Sc. has been conferred on Mr. H. B. Fantham for a thesis entitled "*Spirochaeta (Trypanosoma) balbianii* (Certes) and *Spirochaeta anodontae* (Keysseleit); their Movements, Structure, and Affinities," and other researches in zoology.

Dr. Otto Stapf has commenced a university course of ten lectures on "Grasses: their Structure, Biology, Distribution, and Classification," and Dr. Beddard, F.R.S., a course of four lectures on "The Circulatory System of Reptiles." Both courses are being delivered at University College on Mondays, the botany lectures at 4 p.m. and the zoology lectures at 5 p.m., admission to these lectures being free.

A university course of four advanced lectures in zoology on "Tooth Development and Morphology" will be given by Prof. H. W. Marett Tims, at Bedford College for Women, at 5 p.m. on Tuesdays, commencing March 3. Admission will be free.

Arrangements have been made for university courses in geology by Prof. Garwood, on "The Geology and Physiography of Arctic Europe" (in March); by Prof. Seeley, F.R.S., on "The Thames and its Tributaries" (in May); by Dr. Evans, on "Recent Advances in the Determination of Minerals by Optical Methods" (in June); and by Miss Raisin, on "The Geological Structure of the Area of the Vosges" (in October).

In future, a candidate for the D.Sc. degree may be required by the examiners, as an additional test, to submit within a given period a reasoned report on a subject prescribed by them. Candidates for the B.Sc. honours degree in mathematics as internal students are to be allowed, under certain conditions, to submit research work, and such work will be taken into account in estimating their qualifications.

THE Lord Alverstone, G.C.M.G., Lord Chief Justice of England, will present prizes and certificates to students of evening classes and the day college of the South-Western Polytechnic, Chelsea, on March 13.

THE Board of Education has issued a return (325) showing the application by local authorities of funds for higher education in England and Wales during the official year 1905-6. It appears that the total expenditure on account of education other than elementary during the year was 3,355,434*l.* Of this amount, 706,140*l.* was spent on secondary schools and 234,182*l.* on pupil-teacher centres. On behalf of evening schools and institutions for higher and technical education, 1,200,780*l.* was expended, and in day schools of similar scope 258,517*l.* Exhibitions and bursaries at secondary schools, pupil-teacher centres, evening and day technical institutions, accounted for 376,762*l.* The training of teachers cost 71,910*l.*, and the salaries of officers other than teachers 120,531*l.*, and 150,660*l.* was paid on account of loans. The part of the total amount which was expended in Wales reached 214,185*l.*, more than half of which was devoted to secondary schools.

SOCIETIES AND ACADEMIES.

LONDON.

Royal Society, November 21, 1907.—"Note on the Sensibility of the Ear to the Direction of Explosive Sounds." By A. Mallock, F.R.S.

Soon after the introduction of modern rifles, which give their projectiles a velocity much higher than that of sound, the author noticed that when standing in a position in front of the gun, and not far from the line of fire, the sound seemed to come, not from the firing point, but from some point considerably in advance of the gun. The natural explanation seemed to be that the sound thus heard was not that of the explosion itself, but was caused by the wave-surface, which is generated in the air by the projectile moving at a velocity higher than that of sound. In 1868 the author made observations at the ranges at Broudown to see if the apparent directions agreed with this supposition; and in the present year he has again made similar experiments in much more favourable circumstances. It is clear (if the source of the sound is due to the wave caused by the projectile) that the apparent direction of the sound will be the normal to the wave-surface, and that if the direction of this normal is known, the velocity of the projectile, at the time that that particular portion of the wave-surface was generated which ultimately reaches the observer, can be calculated.

These observations are now recorded, not as giving a practical method of ascertaining the velocity of projectiles, but as showing that the ear can distinguish with considerable accuracy the direction of a sound which consists, not of a train of waves, but, at most, of two waves only. The figure gives the plan of the range and the stations at which the observations were made.

The arrows through these points show the direction of the sound as judged by ear. Each arrow is the mean

of eight observations, which rarely differed among themselves by more than two or three degrees.

That portion of the wave-surface which passes the observer at any station was generated at the point where the apparent direction of the sound cuts the line of fire, and since the trace of the wave on the trajectory necessarily has the velocity of the projectile at the place where it was formed, and moves along the normal with the ordinary velocity of sound, it is plain that at those points the velocity of the bullet is the velocity of sound \div the sine of the angle which the tangent to the wave-surface makes with the trajectory.

The spots, +, show the velocities thus computed, and the full curve gives the actual velocity, as determined by firing, at various ranges up to 1000 yards, into a ballistic pendulum.

The agreement of the values of the velocities thus obtained with the true velocities shows the degree of accuracy with which the direction of the sound was estimated. In this case the difference between the true and observed directions was seldom more than a few degrees, and was generally in one direction.

A sound which is caused by the detached waves, such as those which accompany a bullet, can scarcely be said to have a pitch, but the wave-length is certainly small

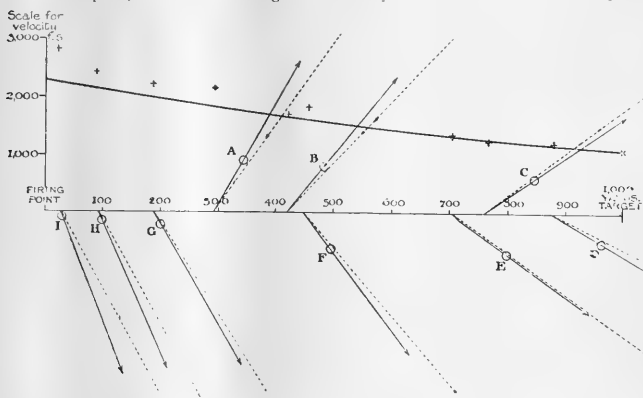

The arrows show the apparent direction of the sound at the stations A B C . . . The dotted lines are the normals to the wave-surface, calculated from the known velocity of the projectile. The full curve is the velocity of the projectile, obtained from experiments with the ballistic pendulum. The spots, +, are the velocities of the projectile, as deduced from the observed direction of the sound.

compared with the distance between the ears, and is, indeed, comparable with the dimensions of the bullet itself. It would seem, therefore, that the ears can determine the direction of a sound, not only by difference of phase, but by the actual difference in the times at which a single pulse reaches them.

"Results of the Interaction of Mercury with Alloys of other Metals." By Dr. J. W. Mallet, F.R.S.

It being well known that alloying metals with each other often modifies notably their relations to acids and other non-metallic reagents, it seemed desirable to ascertain what the behaviour would be of solid alloys to liquid metallic mercury.

In the experiments reported in this paper three alloys were used, namely, tin-platinum, silver-platinum, and copper-tin, approximately $PtSn_2$, $PtAg_1$, and $SnCu_4$. These were shaken up in a finely divided state with pure mercury in large excess. In the first case the tin was completely protected by the platinum from amalgamation, and neither of the solid metals was dissolved by the mercury. In the second case the presence of the silver brought about amalgamation of the platinum, which would not have been so affected if alone, and both metals were dissolved by the mercury, the platinum, however, in less proportion than that in which it was present in the solid

alloy. In the third case, mere traces of the copper and tin were dissolved by the mercury, although each of the constituent metals of the alloy would by itself be readily taken up. A solid amalgam was, however, formed.

These experiments, which were interrupted by illness of the author, go to show that the relations of mercury to alloys are not the same—at any rate for those tried—as to the component metals taken separately.

December 5, 1907.—"The Reciprocal Innervation of Antagonistic Muscles. Note XI. Further Observations on Successive Induction." By Prof. C. S. Sherrington, F.R.S.

This communication announces that an essential part of the flexion-reflex of the limb is a contraction of the extensor muscles which sets in immediately the external stimulus which excites the reflex is discontinued. The external stimulus, it may be recalled, while exciting the flexor muscles to contraction, produces relaxation of their antagonists, the extensors. This latter it effects by quelling (inhibiting) all nervous discharge for the time being in the extensor moto-neurons of the spinal cord. The inhibition of the moto-neurons is on cessation of the stimulus followed by a superactivity in them accompanied by the discharge of impulses from them into the muscles they innervate, namely, the extensors. This tendency to motor discharge which follows from the inhibition had been noted in previous communications by Prof. Sherrington, but the evidence of it had hitherto been only indirect. It had been found that on withdrawing the inhibitory stimulus the inhibited part of the reflex arc showed itself more easily excitable by stimuli than it had been before the inhibition occurred.

In the present communication it is shown that the inhibited centre actually discharges spontaneously on withdrawal of the external inhibitory stimulus that depresses it. It is further shown that the inhibited centre will spontaneously discharge even in face of a weak inhibitory stimulus if that stimulus follows on a strong inhibitory one. The inhibition of the arc leads to or induces a subsequent superactivity of the arc is called *successive induction*, because of its analogy to certain processes in the physiology of vision which are also called inductive. The intensity of the successive induction increases with increase of the intensity of the inhibitory stimulus and with increase—up to certain limits—of the duration of the inhibitory stimulus. In other words, the stronger and longer the inhibitory stimulus, the greater the contraction which ensues on the withdrawal of the stimulus.

The contraction of the extensors of the limb which thus follows on their relaxation by reflex inhibition is probably an important, perhaps the most important, factor in the extension phase of the reflex stepping of the limb. Its occurrence supplies an explanation for the relatively poor representation of extension as a primary movement in the motor area of the cortex cerebri. It may be fundamentally analogous to the excitation which occurs in a peripheral nerve at the site of the anode of a voltaic current when the passage of the current is broken. It is, at any rate, perhaps the most striking instance known of a depression which in Arniem v. Tschermak's terms is *alloonomic*, being followed by a reverse condition the process of which is *autonomic*. In other words, an *alloonomic depression*

(? assimilatory) of the nerve-centre induces an autonomic (? dissimilatory) excitation.

Geological Society, January 8.—Sir Archibald Geikie, K.C.B., Sec.R.S., president, in the chair.—Chronology of the Glacial epoch in North America; Prof. G. F. Wright. In the case of Plum Creek, Lorain County (Ohio), the study of the activity of the stream, and of the amount of work done since the Glacial epoch has yielded important results. This stream began erosion when the temporary lake, held up by the ice, was maintained at the level of its Fort Wayne outlet; it has never had anything more resistant than Till to act upon. From a section 5000 feet long it has excavated 34 million cubic feet of Boulder-clay, removing it from exposed banks 1600 feet long. Twelve years' erosion of a 500-foot length of a part of the trough of the stream gives a rate of 8450 cubic feet per annum. Therefore, the removal of 34 million cubic feet from the 500-foot section would give a period of 2505 years. The erosion of the Niagara Gorge began later than that of Plum Creek, and dates from midway between the disappearance of the ice from northern Ohio and from Quebec. If conditions have been uniform, the age of the gorge would be 7000 years. The author concludes, with some confidence, that the gorge is less than 10,000 years old, and that the ice of the Glacial epoch continued down to that time to such an extent over the lower St. Lawrence Valley and Central New York that it obstructed the eastern drainage of the Great Lakes.—The application of quantitative methods to the study of the structure and history of rocks; Dr. H. C. Sorby, F.R.S. The angle of rest in the case of sand-grains of varying size and quality enables the velocity of current necessary to keep sand drifting, and that needed to move it when at rest, to be ascertained approximately. The comparison of this angle with that in sedimentary rocks made of similar materials may be used to determine the vertical contraction of rocks since deposition, the average in cases studied in Tertiary and secondary rocks being from 100 to 57. The connection between the structure of "ripple-drift" and time is discussed. The connection between the structure of a deposit and depth of water is found to be difficult to study quantitatively. From the occurrence of "drift-bedding" the depth of water may be determined to within a few feet. The deposition of fine deposits, like clay, varies according to the amount of mud present and whether the grains subside separately or cohere together. When no pressure is applied, the amount of water included in the deposited clay may be 80 per cent., and when dry the empty spaces may still amount to 32 per cent. Many of the older rocks must now be only 20 per cent. of their original thickness. In the green slates of Langdale the volcanic eruptions sometimes occurred probably within a few weeks of one another, and at other times at more distant intervals. When deposited, part of the rock was probably analogous to fine, loose sand, and part to semi-liquid mud. In the Coal-measure sandstones deposition at the rate of 1 inch per minute was common, with intervals of little or no deposit. The volume of invisible cavities in rocks varies from 49 per cent. in some recent rocks to nearly 0 in the ancient slates. The packing of grains was discussed mathematically and experimentally. The methods of determining the volume of minute cavities in rocks were given. In some limestones the cavities have been reduced by pressure to close on the mathematical minimum, whereas in others the cavities are filled with carbonate of lime. Some oolites have had their cavities filled in a similar manner; in others most of the material of the original grain has been removed, and the present solidity is due to the filling-up of the cavities mainly by internal segregation. Among fine-grained rocks, the Chalk probably was originally a sort of semi-liquid with 70 per cent. of water, and in its present state is about 45 per cent. of its original thickness; the thickness of some clays must have diminished still more. By the measurement of green spots in slates it can be deduced that the rock before cleavage was more consolidated than rocks of the Coal-measures now are, and was then greatly compressed. The development of "slip-surfaces" in cleaved rocks is great, and furnishes additional proof that the cleavage is of mechanical origin. The volume of

minute cavities in clay-rocks and their analogues of various ages were discussed. There is a distinct relation between it and the probable pressure to which the rocks have been exposed.

Zoological Society, January 14.—Prof. J. Rose Bradford, F.R.S., vice-president, in the chair.—Mammals obtained in the Shantung Peninsula, N. China, by Mr. M. P. Anderson, for the Duke of Bedford's exploration of eastern Asia; O. Thomas. No mammals had come from this region since the time of Consul Swinhoe, who visited it in 1866-8. The present series contained 106 specimens belonging to six species, of which one was new.—The musculature and other points in the anatomy of the engystomatid frog *Breviceps verrucosus*: F. E. Beddard.—The hermaphroditism of the amphipod *Orchestia deshayesii*, Audouin: C. L. Boulenger.

Linnean Society, January 16.—Prof. W. A. Herdman, F.R.S., president, in the chair.—Stages of soil denudation and forest destruction in the Tyrol: A. P. Young. Slides were shown from photographs taken in two valleys, one north of the Brenner Pass, the Navistal, near Innsbruck, and one south of the pass, the Schaldertal, near Brixen, illustrating various limits, commencing near the upper limit of the vine cultivation at about 700 metres to the snow limit at about 2800 metres. Great waste of soil is caused in forest land by the simultaneous felling of trees over single plots of ground, and in the higher levels by the encroachments of grazing animals. One effect of this waste is the recession, not only of the tree line, but also of the limit of continuous forests, which is generally considered as distinct from the tree line.—Notes on Brassica crosses: A. W. Sutton. The origin of some of the cultivated forms of Brassicas has been very obscure, and this has led to much confusion in their classification. It has naturally been supposed that by careful study of those types which intercross with one another, and of those which refuse to intercross, some light might be thrown upon the origin of many Brassicas which to-day form so important a portion of the plants used in agriculture and horticulture. Consequently, experiments were undertaken to investigate the tendency or otherwise to intercross. Various accepted forms of *Brassica oleracea* (such as kale, cabbage, savoy, and Brussels sprouts) were planted side by side and allowed to flower and seed. Result:—A large collection of nondescript plants, some of which, after selection, have been practically fixed as new and useful types. Some of the generally accepted types of *Brassica oleracea* were arranged in "sets" together with types of *Brassica campestris*, *B. rapa*, and *B. napus*, that is to say, swedes with rapes, cabbages with turnips, &c., and these were allowed to bloom in juxtaposition. Result:—Many hybrid plants resulted from certain "sets" where natural cross-fertilisation took place, and in other cases the pure parental types were reproduced when no cross-fertilisation occurred. The results were quite in accordance with what experience led the author to expect. As in the preceding experiments several types had been seeded together, the experiments were repeated under carefully controlled conditions in order to find by artificial cross-fertilisation to which of the types the resulting hybrid forms were due. Artificial crosses (about eighty-six) were attempted between many of the different types of Brassicas. As was expected, many attempted crosses failed to produce hybrid forms, no seed being developed, probably showing that in these cases crossing was impossible. Other crosses gave seeds, in some cases these being well developed, but in others small and immature. These seeds when sown produced intermediate or hybrid plants quite unlike the parental forms, thus showing that cross-fertilisation was possible and had occurred, confirming experience gained in the practical work of seed-growing.—Revision of the genus *Illigeria*, Blume: S. T. Dunn.

Chemical Society, January 16.—Sir William Ramsay, K.C.B., F.R.S., president, in the chair.—Colour and constitution of azo-compounds, part II., the salts of β -hydroxy-azo-compounds with mineral acids: J. J. Fox and J. T. Hewitt. The authors accept Tuck's statement that benzeneazophenol and its ethyl ether are similar in structure, but not his hypothesis that this structure is of the

azo type. They also regard Baker's attempt to formulate these compounds as carbonium salts as unsatisfactory, since it would involve an assumption that β -bromobenzene-azophenol hydrochloride is identical with β -chlorobenzene-azophenol hydrobromide, and they suggest, instead of the formulae hitherto proposed, the constitution of oxonium salts for these substances thus, $\text{NHPH.N:C}_6\text{H}_4\text{:O(H or Et)Cl}$.—A new method of determining vapour densities, part i.: **P. Blackman**.—Studies in the camphane series, part xxv., action of diazomethane on the two modifications of isonitrosocamphor: **M. O. Forster** and **H. Holmes**. Diazomethane produces with the stable isonitrosocamphor the N-methyl ether, whilst with the unstable modification isomerisation to the stable variety only takes place.—The oxidation of aromatic hydrazines by metallic oxides, permanganates, and chromates: **F. D. Chattaway**. Experiments on the oxidation of a number of hydrazines have afforded evidence of the correctness of the view already put forward by the author that an unstable hydroxyhydrazine is first produced, which, in presence of alkalis, breaks down into the hydrocarbon, nitrogen, and water.—Studies in fermentation, part ii., the mechanism of alcoholic fermentation: **A. Slator**. A number of conclusions are drawn as to the relative velocities with which the four principal hexoses are fermented by living yeast, and it is shown that the results can be explained on the assumption that the reaction, which mainly controls the velocity of fermentation, is the decomposition of a stable compound between the enzyme and the sugar. Yeast appears to contain *glucosylase*, fermenting dextrose and levulose; *galactosylase*, fermenting galactose; and *mannosylase*, fermenting mannose.—Organic derivatives of silicon, part iv., the sulphonation of benzyloxypropylsilyl oxide and of benzyloxydipropyl silicane: **H. Marsden** and **F. S. Kipping**. The authors have prepared benzyloxypropylsilyl oxide, and find that on sulphonation it furnishes a sulphonic acid identical with that previously resolved into optical isomerides, so that there can now be no doubt as to the constitution of this substance.—The formation and reactions of imino-compounds, part vi., the formation of derivatives of hydriindine from *o*-phenylenediacetonitrile: **C. W. Moore** and **J. F. Thorpe**.—Valency: **J. A. N. Friend**.—The esterification constants of the normal fatty acids: **J. J. Sudborough** and **J. M. Gittings**. The value E_{MeOH}^{15} for formic acid is 1124, acetic 104, propionic 92, and from butyric to stearic varies from 50 to 54.—The anomalous behaviour of the hydrogen electrode in solutions of lead salts and the existence of univalent lead ions in aqueous solutions: **H. G. Denham** and **A. J. Allmand**.—Amphoteric metallic hydroxides, part i.: **J. K. Wood**.—The use of pyridine bases as hydrogen carriers: **W. E. Cross** and **J. B. Cohen**. It is shown that pyridine facilitates the chlorination of benzene and toluene, and the bromination of the same hydrocarbons and of chlorotoluene and naphthalene.—Decomposition of hyponitrous acid: **E. Divers**.

EDINBURGH.

Royal Society, January 20.—**Prof. J. C. Ewart**, F.R.S., vice-president, in the chair.—The arterial pressure in man, i., methods: **Dr. G. A. Gibson**. A brief historic sketch of the methods used and instruments devised to measure the arterial pressure was followed by a demonstration of **Dr. Gibson's** own improved form of sphygmomanometer. The records of the pulsations were obtained in the usual way by pointers moving over a smoked surface rolled round a slowly rotating vertical cylinder. To estimate the pressure, the method introduced by Riva-Rocci was adopted. It consisted in compressing the brachial artery above the elbow until the radial artery ceased to beat. The compression bag was connected by flexible tubes with a mercury manometer, the pressure value of which was indicated by a float to which one of the recording pointers was attached. The radial pulsation was recorded by a transmission sphygmograph. As the pressure on the radial artery was gradually diminished by opening the valve the oscillations of the mercury began to increase in amplitude, and at a certain point the radial pulsations began to show themselves. The pressure in the mercury manometer,

as given by the height of the record above the abscissa at the instant when the radial sphygmograph began to show distinct oscillations, was the measure of the systolic pressure. The gradual diminution in average pressure of the compressing bag as measured by the manometer was accompanied by an increase in amplitude of the oscillation until a certain average pressure was reached, followed by a decrease until the pressure was the ordinary atmospheric pressure. The lowest point of the maximum oscillation was taken to be the diastolic pressure. The two simultaneous records thus obtained gave all the data at a glance. Interesting examples of records were shown bearing upon various diseases and abnormalities.—Seismic radiations, ii.: **Dr. C. G. Knott**. On the assumption of a particular law of variation of the speed of propagation of elastic waves with distance from the earth's centre, the forms of the rays and the times of propagation along them were calculated and compared with the results of observation. The conclusion was that the observed facts of the transmission of the preliminary tremors could be co-ordinated on the assumption that throughout all but a comparatively thin crust of the earth the elastic waves of highest speed were transmitted with a speed of 12.23 km. per second, and that within this crust, of thickness equal to one-tenth the radius, the speed increased from the value 6 km. per second at the surface to the value 12.23 at the depth one-tenth of the radius. The second phase of the preliminary tremors was similarly transmitted, but with speed less than that of the first phase in the ratio of 18 to 31.3. The hypothesis that the two phases represented the compressional and distortional waves led to the conclusion that the interior of the earth satisfied the uni-constant elastic theory associated with the names of Navier and Poisson. The curving of the rays within the crust of variable speed of propagation led to a concentration of the energy towards the immediate neighbourhood of the epicentre, a result which had important bearings upon the interpretation of seismograms from distant stations.

PARIS.

Academy of Sciences, January 27.—**M. Henri Becquerel** in the chair.—The emission spectra of varieties of fluor-spar: **Henri Becquerel**. The peculiarities recently pointed out by **A. Dufour** in the spectra of fluor-spar as regards the Zeeman effect are probably due to the presence of rare earths in the spar.—Concerning a hitherto unknown fragment of the "Opus tertium" of Roger Bacon: **P. Duhem**. This manuscript, No. 10,264 in the Bibliothèque nationale, is headed "Liber tertius Alpetragii." **M. Duhem** surmises that it is really a portion of the "Opus tertium" of Roger Bacon, and points out that it indicates a clear knowledge of the composition and explosive power of gunpowder before the middle of the thirteenth century.—The geological history and phylogeny of the Anthracotheridae: **Charles Depéret**.—A class of surfaces: **M.**

Tzitzéica.—The equation $\frac{\partial^2 z}{\partial x^2} - \frac{\partial z}{\partial y} = 0$: **Eugenio Elia Levi**.—The definition of the area of a portion of a curved surface: **E. Cartan**. The author points out that his note of December 30 last on this subject has been anticipated by **M. Schwarz**.—The theory of thin bodies: **Eugène** and **François Cosserat**.—The action of the X-rays on the photographic plate: **M. Chanoz**. These experimental results show a parallelism between the successive aspects presented for increasing irradiation by radiographic and photographic negatives. It furnishes an argument in favour of the luminous nature of the X-rays.—The abnormal mobility of the ions of some rare earths: **Jules Roux**. With the exception of the samarium ion, the mobility of which is of the order of the usual monovalent ions, the mobilities of the other earths studied (lanthanum, yttrium, cerium, and gadolinium) are greater than those of monovalent and divalent ions. This difference may be of use in the separation of these metals, pointing to a possibility of effecting their separation by diffusion or by electrolysis.—The radio-activity of the waters at Plombières: **André Brochet**. These researches confirm a point already established, that, contrary to a view very commonly expressed, there is no relation between the radio-activity of a water and its temperature.—The dissociation by water

of the double chlorides of dimercuriammonium and ammonium: H. **Gaudechon**. The compounds

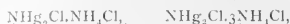

in presence of water at the ordinary temperature behave as true double salts.—The establishment of the constitutional formula of fenone: L. **Bouveault** and M. **Levallois**. The authors regard their experimental work as definitely eliminating the formula suggested by Wallach, and giving great probability to that of Semmler.—The essence of *Magnolia kobus*: Eug. **Charabot** and G. **Laoué**. This essence consists chiefly of citral (15 per cent.) and anethol.—The volcano of Siroua, Moroccan Anti-Atlas: Louis **Gentil**.—Researches on the pulp called Notté flour: A. **Goris** and L. **Crété**. The name flour applied to this substance, which is obtained from the fruit of *Parkia biglobosa*, is a misnomer, as it contains no starch. It is rich in fatty matter, phosphates, and sugar (saccharose). As regards the latter, it contains about 25 per cent. of saccharose and 20 per cent. of glucose and levulose, and surpasses either the sugar beet or sugar cane.—The erythrolytic function of the spleen in fishes: Richard **Blumenthal**. In fish the spleen appears to be normally the place where the red corpuscles of the blood are destroyed.—Modifications of the blood caused by the injection of atropine or of peptone: MM. **Doyen** and Cl. **Gautier**.—Bovine bacilliform proplasmiosis observed in the neighbourhood of Algiers: H. **Soulié** and G. **Roig**.—An attempt at grafting articular tissues: Henri **Judet**. These experiments were made on rabbits, dogs, and cats, and show that it is possible to repair a loss of articular cartilage by the transplantation of fragments arising either from the costal cartilages of the same animal or the articular cartilages of an animal of closely allied species.—The nature of the urns of the Siphuncles: J. **Kunstler**.—*Bacillus endolithus*, a new bacterial parasite of the hair: Fernand **Guéguen**.—A Laboulbeniaceæ, *Tremomyces histobolus*, an endoparasite of the lice (*Menopon pallidum* and *Goniocotes abdominalis*) of the domestic fowl: Edouard **Chalton** and François **Picard**.—The middle Lias in the Seybouse basin (Algeria): J. **Darèste de la Chavanne**.—A neotype of *Pinus (Pseudostrobus) Derancei* in the Lutetian of the Trocadero (Paris): Paul **Combes**, jun.—Characteristics of the foliar trace in genera *Glypteris* and *Tubicalaris*: Paul **Bertrand**.

DIARY OF SOCIETIES.

THURSDAY, FEBRUARY 6.

ROYAL SOCIETY, at 4.30.—On the Weight of Precipitum obtainable in Precipitation with Small Weights of Homologous Protein: Prof. D. A. Welch and H. G. Chapman.—Nitrication in Acid Soils: A. D. Hall, N. H. J. Miller, and C. T. Gimmingham.—A Criticism of the Oponic Theory based upon Studies carried out by Means of Melanin: S. G. Shattock and L. S. Dudgeon.—A Contribution to the Study of the Mechanism of Respiration, with Especial Reference to the Action of the Vertebral Column and Diaphragm: J. F. Halls-Daily.

ROYAL INSTITUTION, at 3.—The Story of the Spanish Armada: Major Martin Hume.

INSTITUTION OF ELECTRICAL ENGINEERS, at 8.—Protective Devices for Rectification of Transmission Circuits: J. S. Peck.

LINNEAN SOCIETY, at 8.—Fruits and Seeds from the Pre-Glacial Beds of Britain and the Netherlands: Clement Reid, F.R.S.—On a Method of Disintegrating Peat and other Deposits containing Fossil Seeds: Mrs. Reid.—On a Botanical Expedition to Fokien: S. T. Dunn.

CIVIL AND MECHANICAL ENGINEERS' SOCIETY, at 8.—Some Devices for the Absorption of Shock on Wheeled Vehicles: F. G. W. ollard.

CHEMICAL SOCIETY, at 8.30.—The Metallic Picrates: O. Silberrad and H. A. Phillips.—Organic Derivatives of Silicon. Part V. Benzylethylsilicone, Dibenzylsilicone and other Benzyl and Benzylethyl-derivatives of Silicane: R. Robison and F. S. Kipping.—Some Physico-chemical Properties of Mixtures of Pyridine and Water: H. Hartley, N. G. Thomas, and M. P. Appleby.—The Constitution of Umbellulone, Part III.: F. Tutin.—The Residual Activity of the Coumarins and Thio-coumarins as shown by their Additive Compounds: A. Clayton.—The Influence of Foreign Substances on Certain Transition Temperatures, and the Determination of Molecular Weights: H. M. Dawson and C. G. Jackson.—The Bromination of *p*-Hydroxydiphenylamine: Miss A. E. Smith and K. J. P. Oton.—Colour and Constitution of *ac*-Methine Compounds, Part I.: F. G. Pope.—The Decomposition of Ammonium Bichromate by Heat. Preliminary Notice: W. M. Hooton.

FRIDAY, FEBRUARY 7.

ROYAL SOCIETY OF ARTS, at 8.—The Hygiene of the Pottery Trade: W. H. Perkin.

INSTITUTION OF CIVIL ENGINEERS, at 8.—Electric Hardening and Anodizing of Furnaces: P. T. Weidner.

ROYAL GEOGRAPHICAL SOCIETY, at 8.—Presidential Address: The Centenary of the Royal Geographical Society: R. S. Herries.

JUNIOR INSTITUTION OF ENGINEERS, at 8.—Aerial Navigation: H. Chatley.

MONDAY, FEBRUARY 10.

ROYAL SOCIETY OF ARTS, at 8.—The Theory and Practice of Clock Making: H. H. Cunynghame, C.B.

ROYAL GEOGRAPHICAL SOCIETY, at 8.30.—The Story of London Maps: Laurence Gomme.

TUESDAY, FEBRUARY 11.

ROYAL INSTITUTION, at 3.—Membranes: Their Structure, Uses, and Products: Prof. W. Stirling.

ROYAL ANTHROPOLOGICAL INSTITUTE, at 8.30.—Additional Notes on New Guinea Games: Dr. A. C. Haddon, F.R.S.—Exhibition of a New Instrument for determining the Colour of the Hair, Skin, and Eyes: J. Gray.

INSTITUTION OF CIVIL ENGINEERS, at 8.—The Erection of the Puller-Lift Viaduct on the Brecon and Merthyr Extension of the Barry Railway: A. L. Dickie.—Notes on the Erection of Cantilever Bridges: Prof. T. C. Fidler.

WEDNESDAY, FEBRUARY 12.

ROYAL SOCIETY OF ARTS, at 8.—The Application of Science to Foundry Work: R. Buchanan.

ROYAL SANITARY INSTITUTE, at 8.—Rivers Pollution, with Special Reference to the Bard proposed by the Royal Commission: Sir William Ramsay, K.C.B., F.R.S.

THURSDAY, FEBRUARY 13.

ROYAL SOCIETY, at 4.30.—*Probable Papers*—The Constitution of the Electric Spark: T. Koyds.—On the Determination of Viscosity at High Temperatures: Dr. C. E. Fawcitt.—The Effect of Hydrogen on the Discharge of Negative Electricity from Hot Platinum: Prof. H. A. Wilson, F.R.S.—The Decomposition of Ozone by Heat: E. P. Herman and R. H. Graves.

ROYAL SOCIETY OF ARTS, at 4.30.—The New Imperial Gazetteer of India: R. Bird.

MATHEMATICAL SOCIETY, at 5.30.—Proof that every Algebraic Equation has a Root: Dr. H. A. de S. Pittard.—On the Uniform Approach of a Continuous Function to its Limit: Dr. W. H. Young.—Note on *q*-differentials: Rev. F. H. Jackson.

FRIDAY, FEBRUARY 14.

ROYAL INSTITUTION, at 6.—Biology and History: Dr. C. W. Saleeby.

ROYAL ASTRONOMICAL SOCIETY, at 5.—Anniversary Meeting.

PHYSICAL SOCIETY, at 8

MALACOLOGICAL SOCIETY, at 8.—Annual Meeting.—President's Address: Malacology versus Palaeoconchology: B. B. Woodward.

CONTENTS.

PAGE

Transpiration and Anatomical Structure in Tropical Plants. By A. G. T.	313
Climate and Man. By Prof. Grenville A. J. Cole	314
The Modern Microscope	314
Mathematical Text-books	315
Our Book Shelf:	
Hatch and Vallentine: "Mining Tables"; "The Weights and Measures of International Commerce"	317
Reyillon: "Les Aciers spéciaux."—A. McW.	317
Hulbert: "Voice Training in Speech and Song"	317
Karny: "Revisio Conceptualiarum"	317
Letters to the Editor —	
The Cotton Plant.—Lieut.-Col. D. Prain, C.I.E., F.R.S.	318
The Inheritance of "Acquired" Characters.—Dr. H. Charlton Bastian, F.R.S.	319
The Nature of Röntgen Rays.—Dr. Charles G. Barkla	319
The Wave-length of Röntgen Rays.—Prof. J. Stark	320
The Orientation of the Aveyru Circles.—Rev. Ed. H. Goddard	320
Stability in Flight.—Major B. Baden-Powell; Herbert Chatley	320
The Stresses in Masonry Dams.—H. M. Martin	320
Some Scientific Centres. No. XII.—The Botanical Institute of the University of Bonn. (Illustrated.)	321
By Prof. D. M. Mottier	321
Examination <i>v.</i> Research. By Dr. F. C. S. Schiller	322
Prof. C. A. Young	324
Notes	324
Our Astronomical Column—	
The Distortion of Photographic Films in Stellar Work	328
Two Hundred New Double Stars	328
A New Astronomical Journal	328
The Study of Meteor Trails	328
The Accuracy of Double-star Measures	328
Forty-one New Variable Stars	329
American Ethnology. (Illustrated.)	329
The Nitrogen Problem in Agriculture. By E. J. R.	330
Mathematical Education and Research	331
Radiography in Pearl Fishing	331
University and Educational Intelligence	332
Societies and Academies. (With Diagram.)	332
Diary of Societies	336

THURSDAY, FEBRUARY 13, 1908.

IS MARS HABITABLE?

Is Mars Habitable? A Critical Examination of Prof. Lowell's Book, "Mars and its Canals," with an Alternative Explanation. By Dr. Alfred Russel Wallace, F.R.S. Pp. xii+110. (London: Macmillan and Co., Ltd., 1907.) Price 2s. 6d.

IN the year 1903 Dr. Wallace published an interesting and fascinating volume entitled "Man's Place in the Universe," a book which created quite a large perturbation in the thinking world. In it he marshalled together a great number of lines of astronomical research, pointed out the deductions which had generally been made from them, and by weaving them together in a masterly way, drew some very definite conclusions from them.

These conclusions he "claimed to have shown to have enormous probabilities in their favour," and two of them, which need only here be mentioned, were as follows:—

(1) That no other planet in the solar system than our earth is inhabited or habitable.

(2) That the probabilities are almost as great against any other sun possessing inhabited planets.

Not only, then, was a wet blanket thrown over many of our favourite dreams relating to the probable doings of living creatures in other worlds, but quite a shock was received when our near neighbour Mars was ruled out of court and declared to be uninhabitable!

We had all become accustomed to regard the changes of hue on the planet's surface as due to the varying tints of waxing and waning vegetable growth. We pictured to ourselves the great ice caps melting away under the heat rays of the approaching summer sun. The germination of the canals and the later duplication of some of them were the means of making the best use of the water after its release from the poles, and the oases served as distributing centres. These and many other variations of absorbing interest all tended to indicate a world of change, very different from the serenity on, let us say, the moon, but more approximating to those of the earth when seen from afar.

If we are to take the view of the writer of this book, such changes must be looked on rather as signs of death than of life, since water, he says, there is none.

During the last decade or more the planet Mars has received a considerable amount of attention. By the energetic, persevering, and painstaking astronomer Prof. Lowell, every portion of the planet's surface has been under close observation, and the surface features have been chronicled on nearly every occasion when favourable opportunities presented themselves.

It is not too much to say that just as the name of Schiaparelli is now, and will always be, identified with the planet Mars, so will that of Lowell be handed down to posterity for his magnificent consecutive series of observations.

In the year 1905 Prof. Lowell published a very

valuable volume describing in great detail, and copiously illustrated with sketches and charts, the observations made by him at the oppositions of 1894, 1896, 1898, 1901, and 1903.

In 1906 he published a volume which was intentionally devoid of technicalities. This was meant to contain a summary of the main results, derived from the discussion of all the data, and his own deductions as to the probable cause or causes of the surface features and their changes. He was led finally to make the following statement with regard to the habitability of Mars:—"That Mars is inhabited by beings of some sort or other we may consider as certain as it is uncertain what those beings may be."

This very definite statement, made after the issue of Dr. Wallace's book to which reference above has been made, has called into being the present small volume by the same author. Although, as we read in the preface, it was commenced as a review article on Prof. Lowell's recent book, it became so extended that it was considered expedient to publish a more detailed examination of the various physical problems involved in order to give a complete presentation of the opposite view held by Prof. Lowell.

In directing attention to the contents of this book it is not proposed to enter into each point of the arguments dealt with, but it will be sufficient to refer briefly to some of them.

The first two chapters are devoted to a general survey of the observations of Mars made by early workers, concluding with those made by Prof. Lowell. With regard to the last-mentioned, the author pays a high tribute to the technical skill and persevering labour of Prof. Lowell, and, while accepting all his observations as valid, only parts company with him "as regards the startling theory of artificial production which he thinks alone adequate to explain them."

The two main topics dealt with in chapter iii. are the questions of the elaborate system of the canals and the water supply. The author takes the view that if the surface of the planet is so wonderfully smooth and level as Prof. Lowell states it to be, then the great network of straight canals could possibly have been constructed by intelligent beings for irrigation purposes. But he points out emphatically here that, if it were so smooth, then such a system would be quite unnecessary, as the water would naturally irrigate as much of the surface as it could reach. If it be admitted for a moment that the polar caps are frozen water, he joins with the late Miss Clerke in the view that the excessively scanty supply of water, coupled with the loss through evaporation, could not possibly serve the innumerable canals.

As the habitability of Mars depends on the presence of water, the question of the evidence for the presence or absence of water vapour is dealt with in chapter iv. Dr. Wallace first directs attention to the observation of the melting polar caps, and the deduction made by Prof. Lowell that this melting and re-forming affirm the presence of water vapour in the atmosphere. It will be remembered that Prof. Lowell observed blue borders on the edges of the polar caps as they melted,

and he stated that "water alone could do this." The author entirely disagrees with this interpretation, "the only proof," as he says, "he gives that the caps are frozen water." He points out that for water to be blue it must be deep, and this cannot be so on Mars because its surface is so level.

He finally indicates that there are two very important pieces of evidence which point to a lack of water vapour on the Martian planet—the spectroscopic evidence, which must be taken into account, entirely negatives the view of the presence of water vapour; and Dr. Johnstone Stoney's proof that aqueous vapour cannot exist permanently there, or on any planet, unless its mass is at least a quarter that of the earth. As the mass of Mars is only one-ninth that of our earth, the planet must have parted with its water vapour many, many centuries ago.

In the next chapter the important question of the probable temperature of the planet is taken in hand, and the author shows to his own satisfaction, and probably to that of the majority of his readers, that the temperature must be far too low for the possibility of any formation of a high form of organic life. He introduces also a note stating the view on this point given previously by Prof. J. H. Poynting, who showed that unless an assumption be made that there exists some quality in the atmosphere of Mars entirely different from any found in our own, the temperature of Mars cannot be as high as the value given to it by Prof. Lowell.

The author ingeniously considers the condition of the Martian atmosphere as being intermediate between that of the earth (a dense atmosphere) and that of the moon (practically no atmosphere). He then refers to many researches on lunar radiation as regards measurements made on portions of the surface exposed and unexposed to the sun's rays. He recalls the important function of a planetary atmosphere, like that, for instance, of our own earth, in retaining and cumulating solar heat and reducing radiation into space. He finally deduces that the Martian conditions of temperature must approximate more to those of the moon than to those of the earth. Further, he lays great stress on the impossibility of the seasonal change at the Martian poles being an apparent freezing and thawing of water, and he expresses his view in the following words:—

"If the moon, even at its equator, has not its temperature raised above the freezing point of water, how can the more distant Mars, with its *oblique* noon-day sun falling upon the snow-caps, receive heat enough, first to raise their temperatures to 32° F., and then to melt with marked rapidity the vast frozen plains of its polar regions?"

In the chapters referred to above the author has presented his views as to the extreme probability of a very low temperature and of the absence of water vapour on Mars, and consequently replies to the question "Is Mars Habitable?" in the negative.

In the remaining portion of the book he makes an alternative suggestion as to the cause or origin of the surface markings and changes recorded on the planet. Just as he stated he had to part company

with Prof. Lowell when he considered the latter's deductions drawn from the discussion of his facts, so we must part company with Dr. Wallace, and disagree with his views on the peculiar, and what seems unique, origin of the planet Mars.

It may be recalled that Prof. W. H. Pickering, next to Prof. Lowell, has made the most minute study of the Martian surface details during the last decade or more. Further, he had the advantage of making his observations under practically similar climatic conditions, and, in addition, he has also closely studied the lunar features under specially fine instrumental and atmospheric conditions.

Prof. Pickering's suggested origin of the Martian canals is that they, like the rifts and streaks on the moon, are caused by volcanic action due to internal stresses set up by the cooling of the planet's heated interior. Dr. Wallace refers here to Prof. Pickering's work, and, like him, looks upon the canals and oases as the results of cooling.

In order, however, to create conditions on a planet which, when cooling, should be capable of producing an enormous network of fissures of large dimensions, and thus give a representation of the chief surface markings as seen on Mars, he suggests the following very ingenious but very questionable mode of planetary formation, rather straining even the very flexible meteoritic hypothesis.

He supposes that the planet began to be formed on the principle of the meteoritic hypothesis, but that the aggregation of the meteorites involved in the process took place so slowly that the heat generated by the bombardments was lost equally quickly by radiation. So gradual, he suggests, did this state of things occur that the planet attained its present size, minus about 50 to 100 miles of the radius, having grown to this dimension "as a solid and cold mass."

He then tells us that this cold mass, in its revolution round the sun, at a later stage of its life, passed through at each revolution a large and dense mass of meteorites. So violent were the impacts that the "inpour of the fresh matter first heated and later on liquefied the greater part of it, as well perhaps as a thin layer of the planet's original surface."

In this way the author produces a thin shell of liquid or plastic material covering a solid and cold interior, which he requires for the explanation of the surface features of Mars. At the termination of this series of annual bombardments this thin shell of heated material would rapidly cool, and, as it is superimposed on a globe of cool matter, craterlets would first be formed, and subsequently large fissures due to contraction. The fissures would have no regard for the equator, but would cross from one hemisphere to the other, as the canals are recorded to do.

The superficial tensions would render the cracks eventually very broad and deep, and where they crossed each other, holes, giving the appearance of oases, would be formed. In time, both fissures and oases would gradually crumble away at their sides, in consequence of the alternate expansion and contraction of the material, due to the presence or absence respectively of the sun's heat.

Although the author accounts for many of the other surface features and changes as recorded on the Martian disc, he is unable to suggest any satisfactory explanation of the doubling of the canals.

Enough, perhaps, has been said to indicate that in these pages we have some very original ideas on a subject of all-absorbing interest. It must nevertheless be left to the reader to form his own judgment as to the probability of the views put forward when he has carefully read the book.

We can unhesitatingly recommend this book to a very large circle of our readers, and more especially to those who have followed the previous publications relating to this subject. The last word on this difficult question has not been said yet, and the present issue will very likely re-ignite the flame.

WILLIAM J. S. LOCKYER.

AGRICULTURE IN FRANCE.

(1) *Races bovinæ. France—Étranger.* Pp. 426. Price 5 francs. (2) *Races chevalines.* Pp. viii + 467. Price 5 francs. By Prof. Paul Diffloth. *Encyclopédie agricole. Zootechnie.* (Paris: J. B. Baillière et Fils, 1908.)

IN the first of these volumes of the Encyclopedia Prof. Diffloth claims that special attention has been paid to varieties, to methods of selection and to breeding, and the author is to be congratulated on the success of his efforts. The book is a very valuable contribution to our knowledge of domesticated cattle; it treats, with commendable breadth and sufficient detail, not only of the characteristics of a great number of breeds and varieties of those breeds, but of certain of the physical conditions under which they thrive and of their geographical distribution.

Part i., which occupies thirty-four pages, begins with a short description of external features, head, body, limbs, teeth, horns, coat and colour, followed by brief notes on some of the anatomical variations which are specially marked in different races.

Part ii. fills the remainder of the book. The classification adopted by the author is based partly on Sanson's scheme of skull measurement, by which all species are divided into two main groups in accordance with the angle formed by a line drawn across the forehead at the base of the horns and a line from the base of one horn to the outer edge of the eye of the same side. When the angle so formed is a right angle, the type is recognised as brachycephalic, when it is obtuse as dolicocephalic. It is pointed out, however, that such classification is by no means a sufficient guide, and that various other external features, such as the form of the crest between the horns, the curve of the horns themselves, &c., must also be taken into account for practical purposes.

Twelve main races are recognised, and these are again subdivided into eighty-five varieties, as follows:—

(1) Low countries, with fifteen varieties; (2) German, three varieties; (3) Irish, five varieties; (4) Alpine, eight varieties; (5) Aquitaine, eight varieties;

(6) Scythian, eight varieties; (7) Vendéenne, seven varieties; (8) Auvergnate, three varieties; (9) Jurassic, fourteen varieties; (10) Ibérique, six varieties; (11) Asiatic, seven varieties; (12) Scotch, represented only by the breed of that country.

Each variety is described; its origin, relation to other breeds, and the effects of crossing are discussed; its special capabilities are examined; the physical conditions of the geographical area it inhabits are generally noted, and their possible effect upon the breed is referred to.

A series of seven maps is of special interest. They are designed to show the areas over which certain races and varieties range, and in some cases their special breeding area is further distinguished. With two exceptions these maps refer to French breeds, the Dutch and Austro-Hungarian races being the only others so treated. This scheme is a most suggestive one, and if consistently carried out would be a very valuable aid both to the student and the practical breeder.

The text is full of valuable information concisely and clearly presented, especially valuable to English readers where it treats of French breeds. Besides figures in the text, many of which leave very much to be desired, there are forty plates, photogravures of selected animals.

The space at our disposal allows of only a very brief notice of the second volume. This book is equally carefully compiled, and is a valuable aid to the student, especially in relation to the natural conditions under which the various races and varieties of the horse thrive.

The author's classification scheme will not, perhaps, satisfy many authorities, but his descriptions of the characteristics of the very numerous varieties he recognises are clear and unbiased, and the figures and plates are good.

His statistics regarding the horse population of the world are no doubt open to criticism, but they cannot be questioned in relation to the conclusion he draws that the advent of the motor-car and agricultural machinery has been followed by an increase both in the numbers and value of horses. The view that Government aid is necessary for the breeding of certain classes of horses in this country receives substantial support from the author's description of the results gained by the care given and the large sums expended by his own Government for this purpose. Short chapters on the ass and the mules conclude the volume.

CHEMISTRY IN THE SEVENTEENTH CENTURY.

Medico-Physical Works of John Mayow (1674). Pp. xxiii + 331; with 6 plates. (Edinburgh: The Alembic Club, 1907.)

ALTHOUGH the name of John Mayow is well known to chemists, there are few who are acquainted with his works. Even the majority of the historians of chemistry have been content to acquire

their knowledge of him at second hand, so that his discoveries and views are generally stated with more or less inaccuracy. This becomes clear on perusing the present work, a translation from the Latin of Mayow's five treatises, for which we are indebted to the Alembic Club.

The basis of Mayow's work was his recognition of the existence in the air and in common nitre of extremely subtle particles to which he gave the name "nitro-aërial spirit." He did not, however, as is often supposed, regard air as a mixture of two gases, as we do to-day, but considered the nitro-aërial particles to be "fixed in the aërial particles themselves," and to be "torn from them by the burning of a lamp or the breathing of animals." They are, in fact, "neither air itself nor some material interspersed among its particles." Whilst the generally received opinion is correct that Mayow recognised that an increase of weight occurs when metals are burnt in air, it is also true that he made but little use of this fundamentally important observation; in the main his experiments were purely qualitative, and ingenious as they often were, they served in many cases to distract the attention from the real issue. Had it been otherwise the course of chemical history might have been different.

When it is remembered that, in Mayow's time, fire and air, mercury, sulphur, and salt were regarded as the fundamental elements, the clearness and originality of his views is very striking. He substitutes his nitro-aërial spirit (which we now call oxygen) for air and fire, and considers that out of the conflict of this spirit with "sulphur" (that is, the combustible constituent of substances) "all the changes of things arise." At each step he feels his way by new experiments, as, for example, when he shows that a mouse, in breathing, diminishes the volume of air like a burning candle, or that, when put in a glass vessel along with a lamp, it will not breathe much longer than half the time it would otherwise have lived. His views on respiration are quite correct; by way of the lungs "the aërial particles enter the mass of the blood and are there deprived of their nitro-aërial particles." The latter are indeed "the principal instruments of life and motion." He scoffs at the idea of a vital flame as a source of animal heat, accounting for the latter by "the nitro-aërial particles in the blood fermenting with its saline-sulphureous particles" (or, as we should say, by the oxidation of combustible material).

It was probably unfortunate that Mayow sought to explain by the aid of his nitro-aërial spirit the most diverse phenomena, such as the elasticity of solids, the nature of light and colours, of lightning and the transmission of nerve impulses, for in so doing the more important facts established were obscured in a haze of speculation which Mayow's early death prevented him from dispelling; thus it happened that exactly a century had to elapse before the work of Scheele, Priestley, and Lavoisier led to a re-discovery of principles already clearly enunciated as early as 1674.

W. A. D.

TOWN GAS.

Town Gas and its Uses for the Production of Light, Heat and Motive Power. By W. H. Y. Webber. Pp. vii+275. (London: A. Constable and Co., Ltd., 1907.) Price 6s. net.

THE opening lines to the preface of this book supply the keynote to all that follows—"This book is a summary of what I know, that appears to me to be likely to interest a generally well-informed but not technically instructed reader about the manufacture of town gas and its uses."

The author, who was for many years the subeditor of the chief organ of the gas industry, has brought to bear his wide knowledge and ripe experience of the subject, and has given us a book that will be welcomed by all consumers of gas who desire an insight into the mysteries of its manufacture, and the best way to consume it for either heat, light, or power. The term "town gas" is used in preference to coal gas in order to cover the admixture of carburetted water gas and coal gas now so often distributed as a town supply, and which was necessitated chiefly by the demand for high candle-power gas, whilst now that the incandescent mantle has rendered rich gas not only unnecessary but wasteful, it is to be sincerely hoped in the interests of the consumer that carburetted water gas will disappear, and that only unadulterated coal gas will again become the general supply.

Excellent as is the book as a whole, there are many points that invite criticism; it was to be expected that the author would be an ardent champion of the virtues of coal gas, but surely when (pp. 175, 176) he is comparing the relative cost of coal and gas as a fuel for domestic use, and debits the cost of coal with a servant's wages and keep at 4*l.* a month, so bringing the cost of the coal as a fuel to 5*l.* 15*s.* a ton, he is going too far, and is more likely to do his cause harm than good. Burnt in properly constructed gas stoves, so arranged that none of the products of combustion find their way into the air of the room, coal gas is an ideal fuel, and, taking into consideration the cleanliness, saving in labour, convenience, and the fact that it need only be used when wanted, it can be shown to be equal in cost at 2*s.* 6*d.* per 1000 cubic feet to coal at 24*s.* per ton, but beyond this its most ardent advocate would scarcely venture to go.

Again, in speaking of the smoke curse and its prevention, he says (p. 227), "Gas is the sole practicable cure for this crying evil"—a statement which would not be endorsed by the advocates of smokeless fuels, such as an anthracite, coke, coalite, or its imitations.

Some small inaccuracies might with advantage be corrected in a future edition; for instance, no gas manager would be inclined to accept as an average example of the normal supply to "the British Metropolitan region" a gas containing 15.52 per cent. of carbon monoxide, 1.5 per cent. of carbon dioxide, and 5.31 per cent. of nitrogen (p. 5).

On p. 69 the author speaks of blue water gas being made by the "methane-hydrogen plant"; this form of apparatus, however, should be deleted from amongst the "blue" gas plants, as its value is dependent upon

its producing a gaseous mixture in which methane plays an important part.

The chapters upon gas lighting and the arrangement of light for indoor and outdoor illumination are excellent, whilst the chapter upon the legal relations of gas suppliers, consumers, and the public should prove of the greatest value to those who desire to gain an insight into the intricacies of gas legislation.

OUR BOOK SHELF.

The Canterbury Puzzles and other Curious Problems. By H. E. Dudeney. Pp. xxiii+195. (London: W. Heinemann, 1907.) Price 3s. 6d.

The author of this little book is a well-known expert in the invention and solution of puzzles. Those which he presents to the reader are in the main entirely original; those which are not so are given in a new dress. Puzzles can be made, as the author says, out of almost any materials, and most people are familiar with specimens made out of matches, cards, coins, &c. Generally speaking, they are in essence either of an arithmetical or geometrical character, and involve, consciously or unconsciously, mathematical processes. An inferior class it is difficult to deal with except by some tentative process which involves no clear line of reasoning; such, for instance, are certain dissection problems which are of the nature of "patience," and are not good exercises for the intellect. Mr. Dudeney may be congratulated on having excluded these from his book.

It is no easy matter to invent a good puzzle; the simplest method would be to modify or generalise a known one; a really new idea is not likely to come from anyone who has not considerable knowledge and power of observation. The author gives shortly the solutions of the puzzles without, in the large majority of cases, explaining them. He recognises that the non-scientific solver is generally satisfied with knowing the solution, and is not curious about reasons; at the same time, he has known how to whet the appetite of more intelligent and curious persons for a knowledge of the principles which underlie the solutions. As an example may be noted the puzzle called "Lady Isabel's Casket." The square top of a box was inlaid with a rectangular strip of gold 10 inches by $\frac{1}{2}$ inch, and for the rest with square pieces of wood, no two of which were of the same size. The puzzle is to find out the size of the top of the box from these data. In his solution of this difficult question, Mr. Dudeney gives you the pattern, and states that the number, size, and order of the squares can be calculated direct from the given dimensions of the strip of gold, and that there is only one possible solution. He then leaves the mathematical reader with an interesting if difficult nut to crack.

The book is written in a popular manner, and is copiously illustrated so as to impart as much human interest as possible into the various questions. The puzzles are of great variety, and will be found interesting and alluring to persons of all kinds.

Matter and Intellect: A Reconciliation of Science and the Bible. By Andrew Allan. Pp. vi+224. (London: A. Owen and Co., n.d.) Price 5s.

This book has value from one point of view only; it is a series of unscientific statements of the very first water. "Now if we suppose that the oceans of the earth are represented by the bright sides of the discs of the radiometer, and the continents by the dark sides, we can understand how the sun attracts the water and repels the land, thus causing the earth

to rotate upon its axis." Even Mr. Allan's more specific attempts to "reconcile Science and the Bible" will provide the average reader with amusement more often than they will scandalise him. "The serpent which tempted Eve was probably a dinosaurian, and may possibly have been the *Iguanodon*, a reptile which 'must have walked temporarily or permanently upon its hind legs,' thus presenting a human appearance, to which its magnificent skin or robe of feathers would add considerable beauty. Eve, therefore, seeing this human-like animal eating of the tree, and suffering no harm, would readily forget the prohibition, and be tempted to try the fruit for herself without any actual speech passing between the two."

Only one serious comment suggests itself when one's capacity for laughter is exhausted. This extraordinary work comes from a writer who has ability enough often to express himself clearly and forcibly, and quotes constantly from the pages of our more august popularisers of science. The schoolmaster admits at least a partial responsibility for the examination blunder. Is the blame here to be thrown entirely upon the pupil?

Leçons sur la Viscosité des Liquides et des Gaz. By Marcel Brillouin. Part i., Généralités. Viscosité des Liquides. Pp. vii+228. Part ii., Viscosité des Gaz. Caractères généraux des Théories moléculaires. Pp. 141. (Paris: Gauthier-Villars, 1907.) Price 9 francs and 5 francs.

BOTH the mathematical and experimental study of viscosity are admittedly of a high order of difficulty, and the author is to be congratulated on the clear and concise manner in which he has developed his subject. After summarising in the first chapter the early work on viscosity, the mathematical treatment of the subject is fully developed in the following four chapters. The second part of the first volume is devoted to a description of experimental work. Each of the principal memoirs is described and subjected to a careful criticism; this part of the book is very complete, and is absolutely free from the tendency to ignore work done outside France occasionally met with in French standard works.

In the second part the theoretical and experimental study are taken together, the relations between the viscosity and the dynamical theory of gases being fully discussed. The concluding chapters contain a general discussion of the molecular theories of liquids and gases.

The work as a whole is characterised by clear exposition, acuteness and fairness of criticism, and completeness. It will doubtless take its place as the standard work on viscosity.

Aphorisms and Reflections. From the works of T. H. Huxley; selected by Henrietta A. Huxley. Pp. vii+200. (London: Macmillan and Co., Ltd., 1907.) Price 2s. 6d. net.

To quote one of these aphorisms, "Time, whose tooth gnaws away everything else, is powerless against truth." There is garnered in Huxley's works so much truth worth wide dissemination that we echo heartily Mrs. Huxley's wish that this book will attract the attention of many persons who are yet unacquainted with her husband's writings. We trust also that this attractive volume, which can be carried in the pocket, will serve to make men of science and students turn oftener to the complete works of this master of lucid expression, who proved conclusively by his essays that it is possible to describe scientific achievements in a manner which will appeal to earnest readers of all classes.

LETTERS TO THE EDITOR.

[The Editor does not hold himself responsible for opinions expressed by his correspondents. Neither can he undertake to return, or to correspond with the writers of, rejected manuscripts intended for this or any other part of NATURE. No notice is taken of anonymous communications.]

The Inheritance of "Acquired" Characters.

DR. BASTIAN is unaccountably mistaken. Nothing in my letter indicates that I "assume (in the face of multitudinous difficulties) that the germ cells of all human beings are potentially alike." I have no doubt that germ cells differ, and therefore that the individuals which arise from them would vary even were they reared under absolutely identical conditions. These germinal differences between individuals and species are rightly termed innate. Individuals differ also because they are exposed to unlike influences during development. These differences, due to the unequal play of stimuli, are rightly termed acquired. But in my letter I did not allude to differences between individuals, nor even to acquired differences between one side of the body and the other. I merely discussed the question whether the terms "innate" and "acquired" correctly distinguished between certain classes of characters. I gave reasons for believing that a nose is no more innate and inheritable than a scar on it. If Dr. Bastian thinks I am in error, will he indicate in what sense the scar is less inborn and more acquired than the nose?

Often we are able to express our meanings very well by inaccurate terms the use of which has been sanctioned by convention. If, then, by "innate" and "inheritable" we merely imply characters which arise under the stimulus of nutriment no great harm is done. But, unfortunately, the words are usually given their literal meanings. The nose is supposed to be more rooted in the germ-plasm, more a product of evolution, more truly inborn than the scar; use acquisitions are treated as trivial accidents unworthy the attention of the student of evolution; as a result, a very important phase of evolution is obscured and the study of it neglected. Dr. Bastian treats as absurd the belief that the bulk of human development after birth is an "acquisition." But, suppose we supplied an infant with sufficient nutriment but denied its body the stimulus of use and its mind the stimulus of experience, what sort of physical and mental maturity would the individual achieve? Would he develop nearly as well as the fetus in the uterus or the butterfly in the chrysalis? How many of his physical and mental parts would attain even the stage of development reached in a little child? Apart, however, from the precise degree in which the human being develops under the influence of use and experience, the points I wish to urge are:—(1) that a principal phase of the evolution of the higher animals is the evolution of a power of responding by growth to these stimuli; (2) that the characters which thus arise are in some species (e.g. man) of great magnitude; and (3) that they are just as much a part of "normal" development as the inborn traits. Variation renders a species adaptable. But the power of developing under the stimulus of experience confers adaptability on the individual as well. In his very interesting letter, Mr. A. Bacot refers to the "repertoire" patterns of "the peppered moth" (NATURE, January 30). Consider how many repertoire patterns are possessed by the human being, whom the environment may train to play the part of an acrobat or a clerk, a beggar or a king.

Dr. Bastian insists that "post-natal growth is essentially due to the same causes as pre-natal growth." His words sound well, but what do they imply in this connection—that use plays nearly as important a part in pre-natal as in post-natal development?

He declares that the memories of Chinese and Mohammedan children are exceptionally good, and accounts for this circumstance by the hypothesis that the memory (the faculty of learning as distinguished from the things that are learnt which are only the contents of the memory) grows in the individual with use, and that this acquisition is transmitted. Animals which are not protected and trained by their parents have little or no memory. It

would be of small use to them, for they must begin life fully equipped for the struggle by instinct. But in proportion as they are protected and trained, they are mentally immature on entrance into the world. The function of parental protection is to afford time and opportunity to make the acquisitions without which they cannot attain maturity, and which in them in some measure take the place of instincts. The helplessness of the human being at birth, and the prolonged training necessary before he is able to maintain independent existence, is connected with the magnitude of his memory and the acquisitions he makes by means of it. Now what is the evidence that memory (the faculty, not the contents) grows with use? So far as I am able to judge, memory, like the homologous power of growing physically, is greatest just when it is most useful—in the little child who has to equip himself with absolutely essential acquisitions, and who, starting from a position of blank ignorance and incapacity, in a few months reduces the chaos of his world to order, and within two years even learns to walk and speak a language, as well as a vast deal more. Has Dr. Bastian any evidence that Chinese and Mohammedan adults are able to learn chapters of the Bible and the Koran more readily than their children? If, then, as seems probable, memory does not grow with use, how can the transmission of acquisitions cause an increase of this faculty in a race?

Southsea, February 9. G. ARCHDALL REID.

MR. BACOT'S interesting letter (p. 204) on melanism in moths suggests that the moth I had seen in Yorkshire (though I knew it appeared elsewhere) has a "repertoire" of colours as an actor has a repertoire of plays, and each moth in his time plays many parts. But the actor learnt them all, and the moth apparently inherits them all, the result being the same, since each possesses them all, and according to environment each appears occasionally "in yellow stockings and cross-gartered," or "in customary suits of solemn black," so that while the actor's knowledge of Hamlet dies with him, the moth's repertoire is perpetuated by an ineradicable involution. The question that lies behind all this does not seem to be answered by reference to the operation of evolution in a "previous epoch," for evolution begs the question. If we say that evolution in the past packed the "germ plasm" with possibilities, and evolution in the present only unpacks here and there one as it is required, we seem to be illogical in the use of any argument founded upon such an uncertain term, for the evolution of an actor and the evolution of a moth are two totally and impossibly different things, yet the stimulus of environment produces the same results.

If we believe that the racial moth has plastic possibilities he may start with whatever form or colour you like, and he will, when it is good for him, become "peppered," and will continue peppered until it is bad for him, when he will become black or otherwise. But if he has to carry a whole load of inherent characters all the time, where, when, and how did his germ plasm "acquire" them? Is what was possible in the past impossible now? And, further, does not the geological statute of limitations forbid the possibility of "cramming" every plant and animal with all these inherent characters during the short time that most species exist?

Dr. Archdall Reid in his most thoughtful letter sends a breath of delightfully fresh air into the subject, for he suggests that, after all, the arguments on both sides of this fascinating subject are not about facts, but words, and suggests (p. 203) that "confusion, misunderstanding, and futile controversy" are due in this matter to the "use of inaccurate terms." The idea of his letter suggests the possibility of a complete explanation of this puzzling question.

If natural selection operated in the past by the slow development of racial possibilities until a fixed type was reached, and if "recapitulation" is established, the "adult" form at any stage short of the last must have had, like the imperfect individual, the power of somehow acquiring characters that it then passed on to its descendants; and if this be so it is difficult to believe that acquired characters are no longer transmitted, for in that

case no new type can possibly arise, and every plant and animal in the world is an "end group," which is utterly inconceivable from the evolutionary hypothesis.

Sunlight is pure and colourless. Under the stimulus of a prism it becomes red, yellow, and blue. If animal form and colour are no more than the prismatic separation of inherent characters preexisting in the germ plasma, it seems to me that the theory of "Darwinian" evolution falls to the ground, and that it is not logical to use arguments founded on that hypothesis to establish conclusions that are fatal to its existence; but I write with a certain trepidation, remembering the fate of the earthenware pipkin that ventured into the stream amongst the iron pots. E. C. SPICER.

Waterstock, Oxford, February 1.

THE slightly dogmatic tone of my original article (January 2, p. 193) under the above heading has called forth quite a number of confessions of failure to understand the modern attitude towards this question. But, though we admire the generous spirit of those who have come forward and made a public exhibition of this failure, we consider that we have contributed our fair share by enticing them out into the open, and that they are asking too much when they try to relieve their very natural embarrassment by appealing to us to tell them what the modern attitude really is.

Ideally, of course, those who by inclination or accident are in touch with recent thought on these subjects ought to be only too glad to impart what they know to others less fortunate—to the aged and to the remote. But practically it cannot be done. The Editor of NATURE would say, perfectly rightly, that the correspondence column of his journal was not the place for enlightening those who fail to keep abreast of modern biological thought.

Dr. Archdall Reid's statement of the real nature of the problem is not a final one of course (as he probably thinks it is), but it is undoubtedly an improvement on the chestnut-old one which asserts that acquired characters are inherited as well as innate ones—a statement which is meaningless, because all characters are both acquired and innate.

If Dr. Bastian and Mr. Spicer have read that part of Dr. Reid's book, "The Principles of Heredity," which deals with this subject, their letters show that they have been unable to understand it. If they have not, it does not seem to us to be profitable to discuss the matter until they have. A. D. D.

Atmospheric Electricity and Fog.

IN view of the interest recently shown in the subject of the dispersion or prevention of fog, it may be opportune to direct attention to a recent remarkable example of an atmospheric electricity phenomenon which usually accompanies London fogs. I should first explain that the method adopted at Kew for determining the absolute value of the potential gradient—i.e. the increase in the voltage per metre of height above the ground—certainly does not err in the direction of overestimating it. Taking eight years, 1898 to 1904, I found in a recent paper¹ that the mean value of the potential gradient at Kew was 159, the mean value for January being 201. The phenomenon referred to above is the occurrence during fog of specially high positive potentials, values double or treble that appropriate to the season being not unusual. At such times, however, there are usually large and frequent oscillations in the value of the gradient, so that the maintenance of an exceptionally high value for a number of consecutive hours is comparatively rare. On the morning, however, of January 21, during an intensely thick fog, the potential gradient at Kew exceeded 730 continuously from 1 to 9.30 a.m. How much it may have exceeded this value it is impossible to say, as the trace was beyond the limits of registration during the whole of this time. Both before the trace left the sheet and after its return the oscillations in the potential gradient were large, so that the maximum value was probably at least 1000.

A question of practical interest is whether the steepness of the potential gradient near the ground during fogs

¹ Phil. Trans., A, vol. ccvi., p. 299.

serves, or may be made to serve, a useful purpose in helping to clear the atmosphere of dust and smoke. It would also be interesting to know whether these high potentials are wholly without physiological effects on the human body. CHARLES CHREE.

National Physical Laboratory, February 5.

The Penetrating Radiation.

MANY writers apparently assume that the penetrating radiation is due to γ -like rays coming from radio-active products in the ground, and is practically constant in amount. It seems probable, however, that the penetrating radiation comes largely from radio-active products in the air, and that it fluctuates greatly in value.

Taking the mean value found by Strutt and Evs for the radium content of sedimentary rocks as 0.9(10)⁻¹² grams of radium per gram of rock, one finds that it is the source of γ radiation which would produce an ionisation on the surface of the ground in air of less than 0.8 ion per c.c. per sec. Now the above value for the radium content is perhaps large for surface soils subject to constant erosion. The actual value found by Cooke for the ionisation in air as due to the penetrating radiation was 4.5 ions per c.c. per sec. McClelland takes the value as 9, and the writer has found a much larger value in the open country during the warm hours of the day. Assuming that the emanation of the radium differs from a depth of 50 cm. or 60 cm. of the ground, one gets a penetrating radiation that will produce a much greater ionisation.

If the penetrating radiation is due to radio-active products in the air, one would expect that it would vary very greatly in amount. The experiments of Jaffe, Campbell, Wood, Borgmann, the writer, and others would indicate this. On the other hand, if the penetrating radiation comes from radio-active products in the ground, its amount should be quite constant. Dike has found that the active deposit which gathers on a charged wire exposed to the air varies greatly with the time of day. Eve, by his charcoal method, has found widely different amounts of the radium emanation in the air at different times. The writer (*Science*, July 12, 1907) has found that during a heavy rain or snow the penetrating radiation decreases very greatly in amount. Rain and snow have been shown to carry down radio-active products, and if the penetrating radiation is due to radio-active products in the air, then its value should be less during a heavy rain or snow.

If the penetrating radiation is due largely to radio-active products in the air, its value in underground cavities should be less than on the surface of the ground. This is what Elster and Geitel found. The writer has found the ionisation in a closed electroscopie to be approximately the same (a) in a cave; (b) in a cistern where there was 4 feet of water on all sides of the electroscopie; and (c) inside a screen of lead and cast-iron blocks. In the open country during August and September (1907) this same electroscopie showed an ionisation during the day some three or four times greater than during the night. In the cave and cistern the ionisation during the day and night was the same. It is natural to suppose that the penetrating radiation was greater during the day, and was due to radio-active products which had diffused out from the ground. During the night the ionisation was not much greater than for the electroscopie in the cave or cistern.

Johns Hopkins University.

W. W. STRONG.

Classification of Secondary X-Radiators.

THE relation between the character of secondary X-radiation emitted by elements when subject to the same beam of X-rays and the atomic weight of the radiating substance has been considered in various papers, but only brief reference has been made to the dependence of the character of the secondary on that of the primary radiation. We have recently made a more systematic study of the relation between the secondary and primary rays.

Although the behaviour of no two substances is exactly the same under the same conditions, yet substances may conveniently be divided into several groups, each consisting of elements which emit a radiation possessing many properties characteristic of that group.

H-S Group.—The elements of this group when subject to a very soft X-radiation emit an almost perfectly scattered radiation of intensity proportional to the mass of radiating substance traversed by a beam of definite intensity.

This conclusion has been based on observations of absorptibility, ionising power, polarisation, and distribution of intensity of the secondary rays.

With a moderately penetrating primary the scattering becomes less perfect—as shown by the above tests—and with a very penetrating primary beam there is considerable difference in character between the secondary and primary rays. This is not due to a superposition of a second radiation on the purely scattered; the purely scattered disappears, and in its place is a radiation more absorbable than the primary producing it, one which is less completely polarised, possesses greater ionising power, and is distributed in a way which exhibits less perfect control of the primary pulses over the radiating electrons.

Cr-Zn Group.—A striking characteristic of this group is the enormous ionisation produced by the secondary beams—of the order of 100 times that produced by an equal mass of one of the (H-S) group. This radiation, though produced by a heterogeneous primary, consists almost entirely of homogeneous rays of a very absorbable type. For certain primary beams there appears to be a more or less perfectly scattered radiation (producing 1 per cent. or 2 per cent. of the total ionisation) mixed with this.

Some remarkable properties of these homogeneous radiations have been referred to in a paper published by us. Their intensity is for large ranges in the penetrating power of the primary proportional to the ionisation produced by the primary beam in a thin film of air, so that it is highly probable that the radiation is produced during the process of ionisation in the radiating substance.

This radiation has not been found to disappear with any changes we have made in the primary beam.

Ag-I Group.—This group is characterised by its sensitiveness to changes in the character of the primary rays when they are of ordinary penetrating power. Though for moderately penetrating primary beams the secondary rays are heterogeneous and do not differ in penetrating power very considerably from the primary, they do not exhibit the polarisation effect and are not distributed in the manner showing scattering as exhibited by rays from the H-S group. These rays are not superposed on a radiation which could be classified with that from the H-S group. We have recently found, however, that some of the group (if not all) may be reduced to order by using a very easily absorbed primary. In this case there appears by every test made to be almost perfect scattering. The intensity, however, appears to be several times as great as that from an equal mass of a substance in the H-S group.

W-Bi Group.—These substances much more closely resemble the Cr-Zn group in the intensity and constancy in character of the rays they emit. They have, however, not yet been examined carefully.

Substances with atomic weights between those in the above-mentioned groups possess some of the characteristics of the two groups between which they lie. It appears possible that similarity in behaviour of all the different groups will be discovered by great variation in the penetrating power of the primary beams—one group when subject to a certain kind of primary beam behaving as another group when subject to a primary of different penetrating power.

The above grouping has, however, been based on the behaviour when subject to beams of ordinary penetrating powers, and the generalisations hold with very few exceptions.

C. G. BARKLA.
C. A. SADLER.

University of Liverpool, January 31.

Auroral Characteristics of Clouds.

This question has often been raised as to a possible connection between the aurora and the formation of clouds in the upper atmosphere. Observers in high latitudes have described cases in which, after a bright aurora, clouds have retained in some measure the forms of the previous

light display. In other cases high clouds have been observed to arrange themselves in a formation very similar to the arch and streamers which are so characteristic of the aurora.

It may be of interest to those who have studied this question to record an exhibition of the latter kind which was observed here yesterday evening. During the greater part of the day the sky had been overcast with altostratus clouds, which, as usual, began to dissipate soon after sunset. Between ten and eleven o'clock (local time) the greater part of the sky was clear, but there remained in the south a mass of light cloud which formed an arch, from which bands spread out in all directions as if radiating from a point on the horizon under the middle of the arch. The effect was remarkably like an aurora except that there was no rapid motion of the bands or streamers. So far as I could judge from the Pole Star, the centre of the arch was due south, and its top about 5° above the horizon, but being on the river at the time in a native boat I had no means of making accurate measurements. Small masses of cloud in other parts of the sky exhibited wave lines, but they did not appear to be parallel to the main streamers, nor did the latter look like a wave formation. In about half an hour the outlines had lost their sharpness, and the whole effect became that of a light, diffuse mass of cloud.

The interest in this observation is two-fold. Those who hold that the clouds which take upon themselves the form of the aurora are due to the same causes as the aurora will be interested to know that this formation can be seen within 16° of the equator, and also that the centre of the arch appeared to be due south. Those, on the other hand, who hold that there is no connection between the two phenomena will feel their position strengthened in that an almost exact imitation of the aurora has been seen in the clouds in a region which is supposed to be almost entirely free from the aurora, thus lending support to the idea that such a formation is only one of the infinite number of possible cloud formations.

GEORGE C. SIMPSON.

Moulmein, Burma, January 13.

Reissner's Fibre in the Frog.

IS October last, at the suggestion of Prof. Dendy, I undertook an investigation into the structure known as Reissner's fibre, which, Sargent's work notwithstanding, is still regarded by many as an artifact or as a coagulum of cerebro-spinal fluid, Johnston even, in his recent work on the "Nervous System of Vertebrates," dismissing the subject with the briefest of notices.

As a more than ordinary interest attaches to the description of any hitherto unrecorded feature in such a well-known type as the frog (*R. temporaria*), I venture to direct the attention of anatomists and physiologists to the fact that this animal possesses a well-developed and easily demonstrable Reissner's fibre, although no reference to this structure can be found in Gaupp's exhaustive treatise, nor does Sargent include any Anuran form in the long list given by him of animals in which he has seen the fibre.

The whole or parts of the central nervous system of about a dozen frogs have been sectionised, the sections having been cut in the usual three planes, and the fibre has been found in all the series examined, showing very definite and constant relations to the various brain structures. In every case it may be made out, beginning anteriorly at the dorsal end of the deep and narrow epynidal groove on the anterior face of the posterior commissure, and emerging from this groove ventral to the commissure, lying freely in the iter spanning the cavity between posterior commissure and cerebellum. It is somewhat closely applied to the ventral surface of the cerebellum, but posteriorly it slopes steeply towards the floor of the fourth ventricle and continues backward, with a wavy course throughout its length, to the hind end of the spinal cord near the floor of the canal.

Beneath the posterior commissure, in one specimen at least, it may be observed dividing into two or more finer fibres, while in the posterior half of its length numerous fine fibre-like structures may be made out, apparently given off to enter the substance of the spinal cord (much as Sargent has described for other forms), but that these

are truly given off by the fibre, and are not merely coagula, I have not yet been able to determine.

In transverse sections a definite sheath to the fibre can be seen, although the fibre itself is not readily made out in these sections until a certain familiarity with its course has first been obtained from an examination of sagittal sections. In the one fibre measured, the diameter was a little more than 6μ .

I did not find in any of my preparations that the fibre curled up into the "tangle" or "snarl" as described by Sanders in Myxine, by Dendy in Geotria, and mentioned by Sargent as commonly occurring, but this may probably be attributed to the precaution that was taken in every case thoroughly to fix and harden the central nervous system before severing the spinal cord. (The brain and spinal cord of several of the smaller specimens were cut entire in sagittal sections.) In all cases the central nervous system was dissected out entire from the freshly killed animal, and, where practicable, under the actual preserving fluid. Zenker's fluid, which did not admit of this, gave less satisfactory results than Flemming's stronger fluid. The stain employed was a modification of Weigert's suggested by C. Judson Herrick.

I have compared the fibre seen in sections so prepared with that shown in sections of *Petromyzon fluviatilis* in the laboratory collection at King's College, and also with that shown in Prof. Dendy's Geotria sections, which were prepared by altogether different methods, and the comparison leaves no doubt in my mind that we have here to do with a perfectly normal structure, and one cannot but express wonder that an object so clearly defined should have for so long escaped notice in the frog.

GEORGE E. NICHOLLS.

King's College, London, February 6.

Rhynchobdella aculeata in Ceylon.

It seems worth while to make a special note of the occurrence of the above-named food-fish in the inland waters of Ceylon. Its near ally, *Mastacembelus armatus*, has long been known to occur here. The general Ceylonese term for fishes belonging to the family Rhynchobdellidae, commonly known as "spined" or "thorny-backed eels," though not nearly related to the true eels, is "teliya," but the natives distinguish between the "Gang-teliya" (river-teliya), which is *Mastacembelus armatus*, and the "Batakola-teliya" (alluding to the lanceolate form of the body), which is *Rhynchobdella aculeata*. The latter is reputed to grow to a length of 15 inches, and I recently examined one of 12 inches. In the former, commoner species, the vertical fins are confluent and the dorsal spines are numerous (about thirty-eight); in the second species, which has not previously been recorded from Ceylon, the dorsal and anal fins are separated from the caudal by a notch above and below; the dorsal spines are less numerous (sixteen), and the long, fleshy snout, which gives these fishes such a remarkable, antiquated appearance, is transversely ribbed below. The identification is therefore not open to doubt.

The Rhynchobdellidae, as a family, are "excellent as food," to quote the words of the late Dr. Francis Day, and the hitherto unsuspected presence of an important member of the family in Ceylon affords an illustration of the incompleteness of knowledge concerning the biological conditions of the local inland fisheries. The batakola-teliya is stated to be absent from Malabar, a peculiarity of distribution which ranges it roughly in the same category with *Channa orientalis*, *Polyacanthus signatus*, and perhaps a few other fresh-water fishes.

ARTHUR WILLEY.

Colombo Museum, January 20.

Poseidonius on the Originator of the Theory of Atoms.

IN Strabo's "Geography," book xvi., chapter xi., § 24, in the description of Sidon, we find the following remark:—

"If we are to believe Poseidonius, the ancient opinion about atoms originated with Mochus, a native of Sidon, who lived before the Trojan times."

This tracing of the theory of atoms to an authority

much more ancient than Democritus does not seem to be mentioned in any of the works on physics, but as it is from the usually accurate Strabo, and rests on the high authority of Poseidonius, it seems worthy of notice.

T. J. J. SEE.

Naval Observatory, Mare Island, California,
January 27.

AGRICULTURAL AND HORTICULTURAL RESEARCH.¹

NO better evidence can be adduced of the growing interest in agricultural education and research in this country than the support which has been given to them by the county councils of Surrey and Kent during the last few years. They have materially promoted the science of agriculture and horticulture by furnishing the necessary means for the annual publication of such valuable reports as the one which



FIG. 1.—Gooseberry shoot attacked by the American Gooseberry-mildew. Numerous dark scurfy patches of the spore of the mildew can be seen on the stem.

has recently been issued from the South-eastern Agricultural College at Wye, Kent.

The report gives the results of an immense amount of painstaking investigation, and the exhaustive way in which the subjects are treated will be appreciated when it is realised that a bulky volume of 438 pages has been produced by the combined labours of the various members of the staff. The work is well written, and the different subjects are presented with pleasing freshness. Altogether we feel that it will prove a veritable mine of immensely valuable information, enhanced in no small degree by some of the most beautiful half-tone illustrations which we have yet seen in a work of this kind.

¹ University of London. "The Journal of the South-eastern Agricultural College, Wye, Kent." No. 16. Pp. ix+428. (London and Ashford, Kent: Headley Brothers, 1907.) Price 6s.; for Residents in Kent and Surrey, 3s.

Apart from the research work connected with the college, we gather that an increasing use is made of this institute "as an advisory centre on matters relating to agriculture and horticulture, so much so that in future years each department of the work of the college will have its special journal." In the section devoted to the report of the economic zoologist, Mr. F. V. Theobald, no less than 119 pests are dealt with, chiefly under the following heads:—those injurious to man's domestic animals, to fruit trees, to pulse, hops, and vegetables, flowers, forest trees, food-stuffs, and those causing annoyance to man; and beside these are some replies to Extra-British inquiries. One of the more interesting portions, issued from this department, is that dealing with the habits of the woolly aphis (*Schizoneura lanigera*). The author has conclusively proved that the damage done by the root form of this pest is much more severe in this country than has been generally supposed. In view of this, Mr. Theobald attributes the failures in treatment because we have hitherto ignored the presence of the migrating ground form. An in-

energy in turning his extensive knowledge of fungi to practical account for the benefit of fruit growers in this country. The detection of the outbreaks of American gooseberry mildew (*Sphaerotheca mors-uvae*) (Figs. 1 and 2) by him was followed by an energetic and tactful campaign to bring about the stamping out of the disease, and his efforts have been rewarded by the introduction of the Bill dealing with fungus attacks into the House of Lords. The Board of Agriculture and Fisheries has now made an order which may be cited as the Gloucestershire and Worcestershire (Gooseberry Mildew) Order of 1907. It came into operation on July 22. This constitutes the first legislative measure against fungus diseases put into force in this country. The fungoid disease of the gooseberry was discovered in the winter of 1906 in some commercial plantations in Worcestershire and Gloucestershire, but it had previously been introduced into Ireland on diseased stock imported from America. It is during the so-called "summer stage" that this mildew spreads most rapidly, as at this period the chains of Conidia are produced in continuous succession day and night.

We gather that the cherry orchards in certain portions of Kent are still seriously affected by the fungus *Gnomonia erythrostoma*, which depends "absolutely for the continuance of its existence on fresh infection taking place in spring by means of the spores scattered from the fruit-conceptacles of the fungus on the dead leaves hanging on the tree." R. N.



FIG. 2.—Six nearly ripe gooseberries which have been attacked by the American Gooseberry-mildew; one healthy berry is shown. (From Ireland.)

jection of carbon bisulphide is recommended for the terrestrial, and a caustic alkali wash for the arboreal form. In a short note on the habits of the house fly (*Musca domestica*), this insect is said to "have bred largely in rotting cow-dung mixed with vegetable matter." We may add, however, that in one of our largest cities, stable middens and ash-pits form the chief breeding places for this fly; anything in the form of decayed vegetable matter, such as the dung of pet animals, vegetables, or even paper, provides food for the larvae, and more especially so where heat is engendered.

Messrs. H. E. Annett, F. V. Darbishire, and E. Russell furnish the report from the analytical laboratory, in which it is stated that 250 samples of various substances were sent in for analysis during the past year. A detailed account is given of some of these; others are dealt with briefly. They are rented under the following heads:—Manures, feeding-stuffs, poisons, milks, waters and soils.

The reports from the botanical department are contributed by the four members of the staff. Mr. E. S. Salmon, the mycologist, has given evidence of his

THE GEOLOGY OF THE TRANSVAAL.¹

THE most interesting features of the report of the Transvaal Geological Survey for the year 1906 are the excellent pieces of detailed mapping of the rocks of the Transvaal System, in the Lydenburg district, between Lydenburg and Belvedere, by Mr. A. L. Hall, and in the area immediately east of the Crocodile River and south of the Rooiberg by Mr. W. A. Humphrey. These two districts form parts of the same great synclinal trough; but while the Lydenburg district is at the eastern end of the trough, and is as remarkable for the simplicity of its geological structure as it is famous for the grandeur of its scenery, the area mapped by Mr. Humphrey lies 200 miles to the west and nearer the centre of the trough, and is characterised by an exceptionally complicated structure. Surrounded by the much later Red Granite formation, the isolated inliers of the Transvaal System in the latter area owe their position to faulting and folding on a large scale, an adequate explanation of which can only be forthcoming when the area to the west is mapped in detail.

In both districts the three members of the Transvaal System are developed—namely, the Pretoria Series, the Dolomite, and the Black Reef Series. The quartzites of the Black Reef Series, which form the lowest division, attain to an unusual development in the northern part of the Lydenburg district, where they form the main portion of the great escarpment of the Drakensberg, and play a considerable rôle in determining the wild character of the scenery.

¹ Transvaal Mines Department. Report of the Geological Survey for the Year 1906. (Pretoria, 1907.) Price 7s. 6d.

"No mere description," says the author, "can convey an adequate idea of the grandeur of the country between Belvedere and Blyde River Poort, where this stream enters the granitic Low Veld area." The escarpment of the Drakensberg "here forms a fine semi-circular curve, cut into by a number of spruits which give rise to precipitous and densely wooded kloofs. Immediately below the edge of this escarpment runs a massive kranz of quartzite nearly 500 feet in thickness." About a thousand feet below lies the great plain of the Low Country, beyond which, on a clear day, the distant chain of the Lebombo Hills can be discerned. The dip of the Black Reef Series being to the west, the escarpment rises eastward until it culminates in two magnificent bluffs, 7500 feet higher than the Belvedere (see Fig.). North of Belvedere the greater thickness of the quartzites produces, under the profound erosive action of the



Portion of the Great Eastern Escarpment of the Drakensberg, S. of Belvedere, formed by the Black Reef Series.

larger rivers, even more striking scenic effects. Thus the Blyde River is mentioned as having carved out a cañon in the quartzites to a depth of more than 2000 feet.

The Dolomite, owing to its more homogeneous composition and consequent absence of marked horizontal features, is characterised by a different type of scenery. Its vertical jointing, however, gives rise to peculiarly pointed kopjes, recalling portions of the dolomite area in the Tyrol. Northward, from Pilgrim's Rest to Hermansburg, the Blyde River flows in a gorge formed by precipitous walls of dolomite. It then travels in a more open valley; but on leaving the Dolomite it cuts its bed down into the Black Reef quartzites by a succession of cataracts and waterfalls until, joining forces with the Treuer River and the Belvedere Creek, it forms the deep cañon mentioned above.

The Pretoria Series presents in the Lydenburg district no feature, either topographical or geological, of especial interest; the same succession of shales, quartzites, and intrusive sheets is met with as in the country further south. The only noteworthy point is the marked thinning out of the series which is observable to the north of Lydenburg. The middle member of the system—the Dolomite—undergoes no great change in thickness, although a thick bed of quartzite (the "Blyde Quartzites") makes its appearance for the first time in the middle of the series; but while the upper member—the Pretoria Series—becomes much attenuated, the lower member—the Black Reef Series—rapidly assumes greater and greater proportions as it is traced northwards. In the extreme eastern portions of the Rand basin, near Springs, the boreholes put down through the Karroo Coal-measures and the Dolomite, to cut the underlying Witwatersrand Beds, showed that the Black Reef Series was represented at the base of the Dolomite by a bed of hard quartzite only 20 feet in thickness (see Hauch, Trans. of the Geol. Soc. of S. Africa, vol. vii., 1904, p. 63). At the Devil's Kantoor, in the Barberton district, it is 110 feet thick; at Mac-Mac, 700 feet; at Belvedere, 1260 feet; while near the northern termination of the Drakensberg, at Mariëps Kop, the series reaches 2550 feet. The horizontal distance across the syncline formed by the beds of the Transvaal System, under the Waterberg and Red Granite formations, from Springs to the Drakensberg escarpment, is only about 160 miles, so that the conditions of sedimentation must have changed rather rapidly, the cause of which is not explained.

It will be seen by the free use made of Boer topographical words in the sentence quoted above that the committee appointed by the British Association at its last meeting "to determine the precise significance of topographical and geological terms used locally in South Africa" should serve a useful purpose. The precise meaning of such words as *kranz*, *butt*, *vlei*, and *kloof* will not be known to the generally of English readers, although *kopje*, *veld*, and *spruit* may have been made familiar by the late war. The report is accompanied by excellent colour-printed maps, and illustrated by beautiful photographic reproductions; but, unfortunately, it lacks an index, and has not even a paged table of contents.

F. H. HATCH.

THE HISTORY OF ARITHMETICAL NOTATION.

THE invention of the decimal notation, which involves the use of zero and the assignment of local value to digits, made such an immense alteration in the character of arithmetical calculations that it would be extremely interesting to know its origin. It became familiar in Europe mainly through Mohammedan sources; hence the term Arabic, as opposed to Roman notation. But the discovery of Sanskrit literature and of Indian works on mathematics led to the theory that the real inventors of the system were the Hindus. The object of Mr. Kaye, in the paper referred to below,¹ is to show that this conclusion has been based on insufficient evidence, and that the whole question requires further and more careful consideration, including a critical study of Indian texts, to avoid being misled by spurious documents. Mr. Kaye gives in the first place a series of arguments which go far to prove that there is no trustworthy evidence for the use of the new notation in India

¹ "Notes on Indian Mathematics.—Arithmetical Notation." By R. Kaye. (Journ. and Proc. As. Soc. of Bengal, new series, vol. iii., No. 7, 1907.)

before the ninth century A.D., and that, if a single inscription prove untrustworthy, we shall have to fix the tenth century as the earliest date attested. Another point on which there can be no doubt that he is right is that the Arabic epithet *hindashi*, applied to the decimal notation, certainly does not mean Indian, the word for which is *hindī*, and cannot be connected with *hindashi* by any regular Arabic method of word-formation; not to mention that *hindashi* usually means "geometrical," and was derived from a Persian word by the Arabic lexicographers themselves. There is no probability in favour of Colebrooke's conjecture that the Indian work translated by Alfarazi was entitled "*Siddh'anta*"; and it is clear enough that after Brahmagupta there was a decline in the study of mathematics in India.

As to Brahmagupta himself, Mr. Kaye points out that in his treatise, side by side with Hero's exact formula for the area of a triangle in terms of the sides, he gives the absurd rule that the product of half the base and half the sum of the other sides is the gross area of a triangle—a survival of a rough approximation similar to those used in Egypt more than two thousand years previously—and this without a word of warning as to when this method would give no approximation at all (though, of course, it should be remembered that in applying this rule, the side most unequal to the others would probably be taken as the "base"). Altogether Mr. Kaye's paper is well worth reading, although he refrains from advancing any definite conclusions of a positive character.

G. B. M.

PROF. J. B. PETTIGREW, F.R.S.

BY the death of Prof. Pettigrew another gap has occurred in the able band who, in the last three or four years of the "fifties" of last century, studied at Edinburgh University. Born in 1834 at Boxhill, in Lanarkshire, young Pettigrew attended first Airdrie Academy and then arts' and a few divinity classes in Glasgow University. Proceeding to the University of Edinburgh as a medical student in 1856, he was first brought into notice in the senior anatomy class of Prof. Goodsir, for by devoting himself to a research on the arrangement of the muscular fibres of the heart he, with 125 marvellous dissections and 120 ingenious drawings, carried off the gold medal. By and by he became president of the Royal Medical Society in Edinburgh, and gave the "Croonian" lecture on the arrangement of the muscular fibres of the heart (after rehearsing it to his fellows in Edinburgh) to the Royal Society of London. He also won the gold medal in the class of medical jurisprudence for an essay on the presumption of survivorship. Next he carried on a research on the cardiac nerves and their connections with the cerebro-spinal and sympathetic system, for which a gold medal was awarded on graduation day, 1861.

After a brief period of office as house-surgeon in Prof. Syme's wards in Edinburgh Infirmary, Pettigrew was appointed assistant curator (under Prof. Flower) in the museum of the Royal College of Surgeons, London. There his remarkable skill in dissection, his stimulating enthusiasm, and his fine preparations of the muscular coats of the stomach, bladder, and other viscera—which he rendered so visible by distending them with coloured plaster of Paris—made his period of office memorable. He also published at this time his memoirs on the arrangement of the muscular fibres of the heart and on the muscular fibres of the stomach and bladder in the *Philosophical Transactions*; and another memoir on the relations, structure, and functions of the valves

of the vascular system in vertebrates (*Trans. Roy. Soc. Edin.*). He further entered into another field, viz. the mechanism of flight, first prominently brought out in his lecture on the subject at the Royal Institution. This was followed by his elaborate and finely illustrated memoir in the *Linnean Transactions*, and, in 1879, by his volume on animal locomotion in the *International Series*.

His health, however, broke down in 1868, and as total blindness was feared he had to relinquish his post at the museum of the Royal College of Surgeons in London and take rest. Improving in health, he, in 1869, accepted the post of curator of the museum of the Royal College of Surgeons in Edinburgh. He held also the offices of pathologist to the Royal Infirmary, lecturer on physiology to the Royal College of Surgeons in Edinburgh, &c. He published in 1874 a volume on the physiology of the circulation in plants, in the lower animals, and in man. Unsuccessfully competing for the chairs of anatomy and physiology in Edinburgh University, his niche was found in the professorship of medicine and anatomy (Chandos chair) at the University of St. Andrews in 1875. His period of office in this chair soon became eventful, as he was appointed the university's representative on the General Medical Council, and in connection with the union of the university with Dundee College. To his labours, and those of one or two others, the university owes the Berry fund of 100,000*l.*, the principal's residence of Scores Park, and the fine Bute Medical Buildings.

In recent years he published various general papers, gave the "Harveian" oration in Edinburgh in 1880, and continued his researches on the mechanism of flight in his private laboratory, where his remarkable machine with its gigantic wings exhibited all his recent experiences. Failing health lately much curtailed his labours, yet, under great weakness, he bravely elaborated a large illustrated work embodying the various researches formerly alluded to and evidences of design in animals. Besides other honours, he received the Godard prize of the French Academy of Sciences, and was made a laureate of the Institute of France.

W. C. M.

W. A. SHENSTONE, F.R.S.

"DISTINGUISHED for his skill as an experimenter, for his ability as a teacher, and for his zeal in the introduction of improved methods of teaching physical science as a branch of general education." Such was the statement of his qualifications for admission to the Royal Society, of which Shenstone became a Fellow in 1898. By his friends he will be remembered for his enthusiastic eagerness in the pursuit of science, by unselfish devotion to what he thought his duty, by his loyalty and good-fellowship, and by the indomitable cheerfulness with which he bore physical suffering.

I made his acquaintance in October, 1871, when, as one of the Bell scholars, Shenstone entered the laboratory of the Pharmaceutical Society in Bloomsbury Square, where I was then demonstrator. After my removal to Clifton College, and feeling the need of an assistant, I was led to think of the young student I had left behind. He accepted the proposal to live under my roof, and thus was laid the foundation of a friendship which persisted without a check to the end. In 1875 Shenstone left me on his appointment as science master at Taunton College, and after about two years removed to Exeter School to take up a similar appointment. Here he built and fitted up a school laboratory, which he described in *NATURE* (July 25, 1878), and which proved that, con-

trary to general belief, a place for teaching physical science practically was not necessarily a very costly affair. Shenstone while with me assisted in various lines of experimental research, and after leaving was good enough to return and devote a whole month of the summer holidays to work in the laboratory. In those days no science master who had ambition to be more than a teaching machine could refresh his own mind or take part in the advancement of his subject save at the sacrifice of recreation, health, and pocket; and the pity of it is that times are not greatly altered in this respect.

In 1880 Shenstone was appointed chief science master at Clifton, and, spite of heavy routine, he managed to carry out admirable and difficult work on ozone, and on the properties of certain highly purified substances, from which he drew the important conclusion that in certain cases two elements can unite together without the presence of that minute quantity of a third substance which had been supposed by some chemists to be invariably necessary.

Shenstone was a skillful glass-blower and an excellent popular lecturer. He was instrumental in introducing vitrified silica as a material for making tubes, flasks and other vessels for laboratory use which are now manufactured in a clear form by Messrs. Johnson and Matthey. The production of this material was described by Shenstone in a lecture at the Royal Institution in 1901.

He died on February 3, after a long illness, at Mullion, South Cornwall, aged fifty-eight; and there he lies in the old churchyard within sight of the Cornish sea, which he so much loved.

Shenstone married in 1883 Mildred, daughter of the late Rev. R. N. Durrant, of Wootton, Canterbury, who survives him, together with a son and daughter.

WILLIAM A. TILDEN.

NOTES.

At the annual general meeting of the Royal Astronomical Society to be held to-morrow (Friday) the president will deliver an address on presenting the gold medal of the society to Sir David Gill, K.C.B., F.R.S., to whom it has been awarded for his contributions to the astronomy of the southern hemisphere and his other astronomical work.

THE Dublin meeting of the British Association will be held on September 2-9 under the presidency of Mr. Francis Darwin, F.R.S. The sectional presidents are as follows:—A, Dr. W. N. Shaw, F.R.S.; B, Prof. F. S. Kipping, F.R.S.; C, Prof. J. Joly, F.R.S.; D, Dr. S. F. Harmer, F.R.S.; E, Major E. H. Hills, C.M.G.; F, Lord Brassey, K.C.B.; G, Mr. Dugald Clerk; H, Prof. W. Ridgeway; I, Dr. J. S. Haldane; K, Dr. F. Blackman, F.R.S.; L, Prof. L. C. Miall, F.R.S. There will also be a sub-section of Section F, to be concerned with agriculture, and the chairman will be Sir Horace Plunkett, K.C.V.O., F.R.S. The first evening discourse will be delivered by Prof. H. H. Turner, F.R.S., on "Halley's Comet," and the second by Prof. W. M. Davis, of Harvard University, on "The Lessons of the Colorado Cañon."

THE death is announced, at the age of eighty-seven, of the Rev. F. Howlett, whose drawings and observations of sun-spots have appeared in various publications, and will be remembered by many students of solar physics.

THE thirty-fifth annual dinner of old students of the Royal School of Mines will be held on Wednesday, March 18, at the Hotel Cecil. The chair will be taken by Dr. R. Pearce.

NO 1998, VOL. 77]

THE Mary Kingsley medal, which was struck by the Liverpool School of Tropical Medicine for presentation to distinguished investigators and others who have aided the cause of combating disease in the tropics, has been presented to Lord Lister, who formally opened the school on April 21, 1899. The medal was forwarded to Lord Lister with a letter signed by Princess Christian (hon. president), Sir Alfred Jones (chairman), Sir Robert Boyce (dean), and Mr. Alan Milne (secretary), in which it was stated:—"No words of ours are required to amplify the esteem in which your magnificent achievements are held throughout the world. The Mary Kingsley memorial medal has been founded for the purpose of recognising the work of those who have accomplished much in the cause of tropical medicine. No one has accomplished more for this cause, or, indeed, for the whole cause of medicine, than yourself. The school feel honoured that your lordship has consented to receive the medal."

WE regret to learn from the *City Press* that Mr. R. J. Friswell, whose name is well known among analytical chemists, died on February 6 after a brief illness. Mr. Friswell studied at the Royal College of Chemistry under Sir Edward Frankland, and later acted as assistant at St. Mary's Hospital to Dr. W. J. Russell. Subsequently he engaged in research work at the Royal College, being appointed in that connection on the staff of the Indian Eclipse Expedition, and later, on his return to London, continuing to assist Sir Norman Lockyer in his spectroscopic researches. Afterwards, for many years, he was the chief chemist to the firm of Brooke, Simpson, and Spiller, leaving them to become the scientific adviser of the British Uralite Company, Ltd. For the last few years he had been in practice for himself as an analytical chemist in Great Tower Street. Mr. Friswell was elected a Fellow of the Chemical Society in 1871, and served on the council for several years; he was one of the founders of the Institute of Chemistry, and last year was chairman of the London section of the Society of Chemical Industry.

WE notice with regret the announcement that Sir J. D. Macdonald, K.C.B., F.R.S., retired Inspector-General of Hospitals and Fleets, died at Southall on February 7 in his eighty-first year. Sir J. D. Macdonald entered the Royal Navy as an assistant surgeon in 1849, and was placed in charge of the Plymouth Hospital Museum. In 1852 he joined *H.M.S. Herald*, and from that date until July, 1859, when promoted to surgeon, he was employed on surveying and exploring service in the south-west Pacific. After many years of almost unremitting microscopic work on the products of the sounding-lead, dredge, and towing-net, he was elected a Fellow of the Royal Society. His next promotion came in 1866, and for nine years he held the post of professor of naval hygiene at the Netley Medical School. In the meantime he was awarded the Macdougall-Brisbane medal of the Royal Society of Edinburgh in 1862, and the Gilbert Blane medal in 1871. He was the author of numerous papers read before the Royal Societies of London and Edinburgh and other societies. His published works also included "A Guide to the Microscopical Examination of Drinking Water," "Analogy of Sound and Colour," and "Outlines of Naval Hygiene." He was made a Deputy-Inspector-General of Hospitals and Fleets in February, 1875, and five years later was again promoted, holding from 1883 to 1886, when he retired from active service, the charge of the Naval Hospital at Stonehouse. In 1902 he was made a K.C.B.

THE February number of the *Strand Magazine* contains two articles of interest to readers of NATURE. In the one,

entitled "The Physiognomist at the Zoo," Mr. A. E. Johnson discourses pleasantly on the expression of animals as an indication of character, his points being brought out by four striking—if somewhat accentuated—portraits of the lynx, the chimpanzee, the mantled guereza monkey, and the lorix. The second article, by Mr. D. M. Beddoe, is devoted to the recently discovered mummy believed to be that of Menephtah, the Pharaoh of the Exodus, and the son of the great Rameses. Photographs of the mummy illustrate the article, so that the reader may look on features familiar to Moses some three thousand or more years ago.

In the January number of the *Quarterly Journal of Microscopical Science* Mr. C. C. Dobell describes the life-history and development of a newly discovered genus and species of flagellate monad (*Copromonas subtilis*) inhabiting the faces of frogs and toads. Starting with the adult monad, it appears that the organism undergoes two distinct phases or cycles of development, one asexual and the other sexual. In the former multiplication takes place by means of longitudinal division, with the eventual development of two flagellas and two nucleuses. In the sexual stage the monads conjugate in pairs, and thus eventually give rise to a dormant cyst, from which, when a suitable nidus is reached, a small hyaline monad is liberated, this in due course developing into an adult monad, when the whole cycle recommences. The cysts are swallowed by frogs or toads, and reach the rectum by the usual course.

THE anatomy and histology of the alimentary tract of the dugong are described in detail by Mr. J. F. Guder-natsch in the fourth part of vol. xxxvii. of Gegenbaur's *Morphologisches Jahrbuch*. At the conclusion of the paper the author refers to some curious resemblances between the sirenian and the cetacean tongue. In that organ in the dolphin there have, for instance, been found certain peculiar pits occupying the position of the circumvallate papillae in other mammals, while the author has discovered very similar pits in the dugong which occupy the position of the foliate papillae. Whether these pits are connected with the sense of taste is, however, uncertain, although the occurrence in both cases of ganglionic cells in the pits is in favour of such a function. An important difference between the sirenian and cetacean mouth is the presence in the former of large salivary glands, which are totally wanting in the latter.

A SERIES of "studies in adaptation" commences in the fifth volume of the *Baltimore Journal of Experimental Zoology* with an article by Dr. Alexander Petrunkevitch on the sense of sight in spiders, a subject discussed with great elaboration and in minute detail. This sense is of the greatest importance to certain species, those which obtain their prey by hunting depending entirely on sight during the chase. Nevertheless, the acuteness of vision even in the sharpest-eyed spiders is far inferior to that of man. An insect of about a square centimetre in size would, for example, be perfectly visible—even perhaps to the extent of specific recognition—to the human eye at the distance of a yard, whereas to a spider of the genus *Phidippus* it would appear as a tiny, ill-defined moving object, while to members of the genus *Lycosa* it would be invisible. The poor visual power of spiders is largely due to the peculiar form of the retina, while the inferiority in this respect of *Lycosa* to *Phidippus* depends on the fact that, while in the latter the retinal image covers the terminations of nearly seven nerve-rods, in the former it scarcely exceeds the diameter of a single rod.

THE best mode of determining the age and rate of growth of eels forms the subject of a long article by Mr. K. J. Gensøe in the report of the Danish Biological Station for 1906, (Copenhagen, 1908). By means of measurements, it has been ascertained that when eels attain a length of about 18 cm. and begin to develop scales, they have lived for two years in fresh water, that is to say, from the time of their arrival as larvae or glass-eels. After this the age may be determined by the number of concentric zones or rings in the scales, which indicate annual periods of growth. The age of any individual eel is therefore the age of the scale + 2. Judged by this test, it appears that in the case of males some assume the silvery breeding-dress (preparatory to descending to the ocean) in about 4½ years after their arrival in fresh water, although the majority do not do so until from 5½ years to 7½ years. The females, on the other hand, assume the silver livery somewhat later, scarcely ever before 6½ years, and in most cases not until 7½ years, while many do not do so until they are 8½ years old or even more, whereas only one male of that age was detected in the course of the experiments. It is during their fourth and fifth years that eels increase most rapidly in girth.

IN an article on the evolution of life, published in the *Century Illustrated Magazine* for February, Dr. Percival Lowell asserts that life is an inevitable phase of planetary evolution, and consequently that every planet must be inhabited by living creatures of some kind during a certain stage of its existence. Mars is at present passing through this stage. The author also considers it demonstrated that in the case of our own planet life originated in the ocean. Very picturesquely does he describe the life of the deep sea. That a blind fauna, he writes, should inhabit the abyssal depths is of itself a sufficiently wonderful phenomenon; but that nature should undertake to light the region, and that by means of its inhabitants, is still more wonderful. And yet "this is precisely what she does, and with something akin to electricity, each animal carrying with it its own machine. Whole tracts are brilliantly lighted up, till they must resemble London or Paris by night, only that in these thoroughfares of the abysses of the sea the passers-by provide the illumination."

PROF. DUNBAR, as the result of a series of experiments conducted over a long period and with every care, has come to the conclusion that the bacteria are not an independent group of organisms, but, together with some of the yeasts and moulds, are stages in the life-history of green algae ("Die Entstehung von Bakterien, Hefen und Schimmelpilzen aus Algenzellen," published by R. Oldenbourg, Munich and Berlin). A pure culture of a single-celled alga belonging to the Palmellacia was obtained, but by modifying the culture medium by the addition of acid, alkali, or traces of copper salts, other organisms, generally bacteria, occasionally moulds and yeasts, and even spirochaetes, made their appearance in the pure cultures. Granting there was no flaw in the experimental methods, and every care seems to have been taken to exclude contamination, the results are susceptible of another explanation, viz. that the secondary growths were derived by transformation of the algal cells, in fact, by the phenomenon of "heterogenesis," which has been claimed by Bastian to occur with certain organisms.

AN editorial in the *Indian Forester* (November, 1907) on "Forestry and Agriculture," advocating the afforestation of some of the large areas of uncultivated or unculturable land in India, touches on a matter of great importance, seeing that so much timber is required as fuel.

It is suggested that the planting of such areas might be undertaken by district boards working in consultation with forest officers.

A PAMPHLET on the fibrous plants of the west coast of Africa, forming the subject of a paper read before the Liverpool Chamber of Commerce by Dr. E. Drabble, has been received from the Liverpool Institute of Commercial Research in the Tropics. The author treats his subject under the groups of leaf fibres, bast fibres, piassavas, and raffias. The first named include species of Agave, Sanseveria, and the oil palm *Elæis*; most of the bast fibres are derived from malvaceous plants; the greater quantity of both piassavas and raffias is obtained from the palm *Raphia vinifera*.

An account of culture experiments undertaken with the object of studying the effect of organic matter on nitrification in impure cultures is contributed to the *Bulletin International de l'Académie des Sciences de Cracovie* (June, 1907) by Messrs. A. Karpinski and B. Niklewski. The authors come to the conclusion that weak solutions of various organic substances, especially humates, and to a less degree acetates, peptone, and sugar, do distinctly promote nitrification processes. Messrs. T. Koźniewski and L. Marchlewski communicate a paper on chlorophyll derivatives, in which they indicate the spectra obtained with solutions of phylloatainin and allophylloatainin.

The first number of the *New Bulletin* for the current year contains diagnoses of new flowering plants, "Decades Kewenses: XLV., XLVI.," by workers in the herbarium, and identifications by Mr. G. Masees of a set of fungi collected in Singapore by Mr. H. N. Ridley. The majority of the fungi are agarics, of which several are new species; a Calodon (Hydnaceæ) and a Geoglossum also furnish new species. An article on the fruit fly, *Ceratitis capitata*, refers to a pest that has caused serious damage to orange bushes and fruit trees in South Australia and other colonies. It has also been reported from the neighbourhood of Paris on apricots and peaches. Kerosene placed in shallow vessels is said to provide an attractive lure that has proved efficacious. Mr. T. A. Sprague contributes a synopsis of the prickly fruited species of *Euoynmus*, of which three are new Chinese plants, and an article by Mr. F. Turner on Australian grasses is reprinted.

THE first of a series of contributions by Mr. T. F. Cheeseman to a fuller knowledge of the flora of New Zealand, constituting an addendum to the author's "Manual," is published in the Transactions of the New Zealand Institute (vol. xxxix.). As a guide for future work, the author indicates the regions that have been insufficiently explored. The notes refer chiefly to new varieties and specimens. The indigenous localities of the handsome shrub *Clianthus puniceus* and the myrtaceous tree *Metrosideros tomentosa* are collated. Illustrations are given of two unique specimens of branched "nikau" palms, *Rhopalostylis sapida*, one showing seventeen irregular branches. Separate papers are devoted to the description of a plant previously named *Trithuria inconspicua*, now transferred to Hydatella, another genus of the same order, Centrolepidaceæ, and to the discussion of the discontinuous distribution of *Pittosporum obcordatum*.

LAND erosion by storm water appears to be going on at a remarkably rapid rate in parts of Cape Colony, and to cause considerable loss to farmers and others. For the past three years the Irrigation Department has been collecting information on its bad effects and on possible remedies, and this is now summarised in the November (1907) number

of the *Agricultural Journal of the Cape of Good Hope*. It is considered that two main causes operate—the burning of forest, of bush, and of grass has destroyed vegetation that used to hold back storm water, and the movement of cattle and waggons, &c., along definite paths tends to wear down tracks in which the water can start its course. Once erosion begins its progress is very rapid. Among the instances quoted we may mention the Ongers or Brak River. Sixty years ago there was no river, but for some cause erosion began, and it has since gone on so rapidly that the river channel is now generally 300 feet wide and 15 feet deep. In order to check the process it is suggested that small channels or "sluits" should be so obstructed by stones, bushes, &c., that the water must distribute itself over a wider area, and do correspondingly less damage. The subject is a very important one, and we trust that the Irrigation Department will not stop at collecting information, but will proceed to a sound and complete investigation of the whole matter.

THE Bulletin of the American Geographical Society, vol. xxxix., No. 11, contains an account of physiographical experiments on the aggrading and degrading stream, carried out at the Ohio State University during the past year. An initial valley of cement was constructed in a water-tight tank, the slope of which could be varied. Fire-clay of unequal fineness was placed above the upper end of the valley, and a fine spray of water turned on. During the aggradation process, the construction of systematic asymmetrical fans over previous flood plain deposits, and the formation and preservation of pits or depressions on the flood plain, were noticed. The latter is the probable origin of the so-called "kettles" of the Susquehanna. Conclusions were also arrived at concerning the relative importance of slope, water supply, and load as causes of the aggradation or degradation of streams, the influence of load being specially emphasised. Finally, Prof. Davis's explanation of alluvial terraces standing above existing flood plains was strikingly confirmed by the action of the experimental river as it carved out its series of terraces.

An account of the astronomical and geodetical observations made in 1902-5 by the German Commission for fixing the boundaries of German East Africa appears in *Die Mitteilungen aus den deutschen Schutzgebieten*, vol. xx., part iv. The report is published in three divisions, the first containing particulars of the Lake Kivu Expedition under Captain Herrmann, with Prof. Lamp as astronomer, and the second and third giving the results of the Deutsche Uganda Grenz Expedition under Captain Schlobach. On the Kivu Expedition, Prof. Lamp established an astronomical station at Usambara, and determined a value for its latitude. Valuable geodetical results, of which full tables are given, were also obtained in this neighbourhood, and with the figures of Captain Schlobach furnish the data for triangulation of a map of the district west and north of Lake Victoria. East of the lake, triangulation was continued from a base at Port Florence, the work being carried as far as Kilimanjaro, and from thence connected with Zanzibar. A map is published showing the boundary line between British Uganda and German East Africa from Lake Victoria to Kilimanjaro. Captain Herrmann also gives an account of altitude measurements made by the Kivu Expedition, and Captain Schlobach a table of those made during the Uganda Grenz Expedition.

THERE are few regions in the world so rich in minerals as the State of Nevada. In addition to gold, silver, copper, and lead, deposits of sulphur, zinc, bismuth, antimony, tungsten, nickel, iron, mercury, arsenic, salt,

and gem-stones are being developed at the present time. The discovery of the great Tonopah gold mine in one of the barren mountains in the desert area of the State caused Nevada to awake from the economic lethargy into which she was plunged after the flooding of the Comstock mines in the early 'eighties, and the closing down of nearly every mine of importance on the other mining fields through the fall in the price of silver. In an interesting review of the recent mining developments in Nevada, Mr. A. Selwyn-Brown, in the *Engineering Magazine* (vol. xxxiv., No. 4), shows that since the Comstock rush in 1850 to the end of 1907 the gold and silver mines of the State yielded the enormous value of 206,670,000. In the *Journal of the Franklin Institute* (vol. clxv., No. 1) Prof. O. C. S. Carter also deals with the mineral resources of Nevada, and describes the irrigation started by the Government Reclamation Service. The irrigation canal, thirty-one miles in length, to divert water from the Truckee River to the Carson River, together with 270 miles of lateral ditches, is completed, and is the first irrigation project carried out under the authority of the United States law of June 17, 1902.

In the December (1907) number of the *National Geographic Magazine*, the organ of the National Geographic Society of Washington, U.S.A., Mr. R. M. Brown describes an experiment intended to give practical proof of the curvature of the earth, carried out by him on Lake Quinsigamond, on the model of the well-known investigations of Mr. H. Yule Oldham on the Bedford Level in this country. The most interesting contribution is that of Hon. J. Wilson, Secretary of Agriculture, entitled "The Modern Alchemist," in which he surveys the multifarious activity of his department in the introduction of new varieties of cereals and other useful plants, arboriculture, forestry, fisheries, and many other subjects.

Mr. F. Soddy is giving a course of six free public lectures at Glasgow University on "The Nature of Matter." He regards them as some slight return to the people of Glasgow for the help given to the University by prominent citizens, especially in the equipment of the department of physical chemistry with apparatus for research, and he believes it to be the duty of men of science who receive such help to place before the public from time to time, and in a manner to be readily comprehended, the principal results achieved. The first lecture, delivered on January 30, dealt with radium and atomic disintegration.

SIR CHARLES TODD has issued the meteorological observations made at the Adelaide Observatory and other places in South Australia and the Northern Territory during the year 1905. The section relating to rainfall gives the monthly and yearly totals at 517 stations, and compares the figures with the average for previous years wherever there are at least seven years' records. The year was a moderately wet one over the older established agricultural districts, but dry over the pastoral country, the interior, and the Northern Territory. From August to the middle of December the weather was very cold in the southern areas; the special meteorological feature of the year was the exceptionally cold spring; February was also the coldest month on record. The useful experiments on the exposure of thermometers have been continued; Sir Charles Todd observes that, as might be expected, the thermometers in the "Stevenson" screens as a rule read higher than those on the "Greenwich" stand during the night and lower during the day; the difference depends very much on the wind-force and the state of the sky. An interesting table shows the approximate mean rainfall

for each month and year from 1861 to 1905, and the average yield of wheat per acre; wheat-growing can be successfully prosecuted only where the percentage of winter rains is largely in excess of that for the summer months.

M. L. NATANSON has an article on the electromagnetic theory of dispersion in gases in the April (1907) number of the *Bulletin de l'Académie des Sciences* of Cracow. After working out the general theory of propagation of electrical disturbances in a medium composed of molecules which contain electrons or "corpuscles" having their own periods of oscillation, he limits his consideration to gases, and assumes, the molecules to contain electrons of one kind only. He finds that in the cases of hydrogen, oxygen, air, and carbon monoxide, the values of the refractive indices calculated on this assumption agree fairly with the values found by experiment. In the case of carbon dioxide the agreement is poor, owing probably to the influence of the absorption bands in the infra-red. In the case of sodium vapour the assumption of two kinds of electrons fails to produce a satisfactory agreement between theory and experiment.

PROF. COHEN has made valuable additions to our knowledge of the allotropic states of the elements, notably in the cases of tin and antimony, and the current number of the *Zeitschrift für physikalische Chemie* (January 31) contains two papers by him (in collaboration with Mr. J. Olie) on the so-called amorphous antimony and bismuth. These were described by Mr. F. Hérard in 1888 as resulting from the action of nitrogen upon these metals at a dull red heat. The experiments now described prove conclusively that neither pure antimony nor bismuth undergoes any change when heated in nitrogen which has been carefully purified from oxygen and oxides of nitrogen. If the nitrogen is not specially purified, however, Hérard's results are reproduced, the "amorphous" antimony (or bismuth) thus obtained consisting of a mixture of the metal and its oxide. These allotropic modifications of the two elements are therefore non-existent.

UNDER the title "A propos de l'État civil de Jean Baptiste van Helmont" the question of the correct dates of the birth and death of van Helmont is discussed by the Chevalier Edmond Marchal in a recent number of the *Bulletin of the Royal Academy of Belgium* (1907, No. 7, p. 732). The researches of M. G. Des Marez among the registers of the cathedral church of Ste. Gudule, Brussels, show that van Helmont was born, not in 1577, as has been generally supposed hitherto, but on January 21, 1570 (N.S.). The date of his death is somewhat less certain, being either November 16, 1635, or December 30, 1644; it appears to be clear, however, that he died in Brussels and not at Vilvorde, where he spent seven years of his life. It is an interesting fact that the bust of van Helmont at the Royal Belgian Academy of Medicine does not represent Jean Baptiste van Helmont at all, but his son François, whose likeness, appearing side by side with that of his father in the first edition of the "Ortus Medicinæ," was confused with it when the bust was carved in 1863.

MESSRS. LONGMANS, GREEN AND CO. have published a fifth edition of "The Old Riddle and the Newest Answer," by Father John Gerard, S.J. The price of the book is 6d.

THE publishing firm of B. G. Teubner, Leipzig and Berlin, has just issued an authorised translation into German, by Dr. J. Friedel, of Prof. Horace Lamb's standard work on "Hydrodynamics." The second English edition was reviewed in NATURE of November 21, 1895 (vol. liii., p. 49), and the third edition, carefully revised and largely

supplemented, was published early in 1906. This is the edition of which a translation has now appeared in Teubner's collection of text-books of mathematical science.

THE fifth volume of the second series of the Proceedings of the London Mathematical Society has now been published by Mr. Francis Hodgson. The volume includes an account of the meetings held during the session November, 1906, to June, 1907, and many of the papers read before the society during the session. Obituary notices are included of the late Colonel Mannheim and Dr. E. J. Routh. As the meetings of the society are recorded from time to time among our reports of societies and academics, it is unnecessary to do more now than mention the publication of the volume containing records of papers presented.

OUR ASTRONOMICAL COLUMN.

OCCULTATIONS OF URANUS IN 1908.—From Dr. Downing we have received, as an excerpt from No. 2, vol. lxxviii., of the Monthly Notices, a table showing the times and angles of immersion and emersion for the occultations of Uranus by the moon observable at British observatories during the present year. The places specifically named are Adelaide, Melbourne, Sydney, Wellington, Natal, Perth (W.A.), and the Cape, and the dates of the occultations are April 22, May 10, July 13, August 9, and October 3. Dr. Downing hopes that the publication of these data will enable astronomers favourably situated to observe some peculiarities in the appearance of the planet at the time of occultation.

OBSERVATIONS OF COMETS 1907d AND 1907e.—The results of the observations of comets 1907d and 1907e, made at the Vienna Observatory with the 6-inch refractor, are recorded by Dr. J. Holetschek in No. 4231 (p. 99, February 3) of the *Astronomische Nachrichten*. Some of them for 1907d are particularly interesting, as, in addition to the brightness of the nucleus and of the comet as a whole, the observer gives the length of tail and the times before sunrise up to which the comet was observable. Thus on July 18, when the brightness of the whole comet was of the fourth magnitude, the brightness of the nucleus being 7.5 mag., the object was followed until 15h. 33m. (Vienna M.T.), that is, until 46m. before sunrise. On August 26, mag. 2.0, it was seen until 20m. before sunrise. The greatest length of tail measured was about 8°, on August 18.

Signor Abetti also records, in the same journal, a number of observations, made at the Arcetri Observatory, of these two objects during November and December, 1907.

PLANETS NOW VISIBLE.—With Mercury at its greatest eastern elongation on February 13, it may be possible, during the next night or two, to observe, with the naked eye, five of the major planets at the same time. On February 13 Mercury will set about 1½ hours after the sun, i.e. at about 6.30 p.m., some 10° south of west. Venus is still quite a bright object in the western sky, while Saturn sets, nearly due west, some three hours after sunset. Mars does not set until about 10.30 p.m., and is to be found in the constellation Pisces to the south-east of the Great Square of Pegasus.

At 6 p.m. Jupiter is now a striking object in the eastern sky, having risen some three hours earlier.

Mercury will, of course, be the most difficult object to locate, but, following the directions given in these columns on December 5, 1907 (p. 115, vol. lxxvii.), Mr. W. E. Rolston found the planet at 6.35 a.m. on December 6, and was able to follow it easily until 7.10 a.m. The observation was made at Wimbledon Park, the sky being clear and the sun rising at 7.51 a.m.

At present Uranus is in conjunction, and therefore invisible, but Neptune may be found, with a telescope, situated between the stars ϵ and ζ and near to η Geminoium.

ENCKE'S COMET, 1908a.—The following is a further extract from the ephemeris for Encke's comet given in

No. 4222 (p. 363, December 18, 1907) of the *Astronomische Nachrichten* by M. Kamensky and Mdlle. Korolkov:—

Ephemeris oh. (M.T. Berlin).					
1908	a (app.) h. m.	δ (app.)	1908,	a (app.) h. m.	δ (app.)
Feb. 12 ...	23 50' 3"	+ 6 21' 0"	Mar. 3 ...	0 27' 0"	+ 10 4' 5"
" 20 ...	0 3' 9"	+ 7 43' 7"	" 7 ...	0 35' 6"	+ 10 56' 1"
" 28 ...	0 18' 9"	+ 9 15' 3"	" 11 ...	0 44' 7"	+ 11 49' 6"

From this we see that the comet is apparently travelling in a north-easterly direction, through the constellation Pisces, and should be sought, in the earlier part of the evening, some few degrees to the south of the Great Square of Pegasus. Its photographic magnitude on January 10 was 12.5, and its distance from both the sun and the earth is decreasing rapidly. According to Prof. Wolf's observations, the above ephemeris required corrections of +2.4m. and -24' on December 25.

Some interesting notes on the successive reappearances of Encke's comet appear in No. 2 (February 1, p. 13) of the *Gazette astronomique*.

A CATALOGUE OF ZODIACAL STARS.—A catalogue of zodiacal stars, principally prepared for use in occultations of stars by the moon, appears as part iii., vol. viii., of the *Astronomical Papers* prepared for the use of the American Ephemeris and Nautical Almanac. This catalogue was prepared by Mr. H. B. Hedrick, and all the catalogues employed in the investigation were reduced to the same absolute system as Prof. Newcomb's Catalogue of Fundamental Stars, which appears as part ii. of the same volume. The catalogue includes 1607 stars, and gives the definitive positions for the epochs 1900.0 and 1920.0. Centennial and secular variations and proper motions are also given.

METEORS OBSERVED ON JANUARY 2.—Observing at Hjørring, North Jutland, Herren P. Muusmann and H. Wanning saw a number of meteors in the region between Cygnus and Pegasus on January 2. The observations were made between 8.10 and 8.20 p.m., and during the last five minutes more than thirty meteors were counted. The position of the radiant is given as $300^{\circ} + 61^{\circ}$ (*Astronomische Nachrichten*, No. 4230, p. 95, February 1).

THE WINDS OF NORTHERN INDIA.¹

THE phenomena of atmospheric motion may be considered and discussed from three main points of view. They may be (1) regarded in their relation to the general system of winds prevailing over a rotating earth unequally heated, and having an annual period of temperature variation; (2) considered in their dynamic relation to the synchronous distribution of the various other meteorological elements, more particularly the pressure and temperature, in their vicinity; (3) arranged in order to facilitate comparison with one another at different times and seasons, and to exhibit the connection between wind and climatic conditions in such a way as to enable account to be taken of this connection in a general survey of meteorological conditions and in relation to forecasts. In the memoir before us, the main feature is the development and discussion, from the third standpoint, of the results of anemographic records at Allahabad and Lucknow during the years 1890-1904 and 1878-1892 respectively. Sir John Eliot prefixes the discussion by a respectively short account of the synchronous distribution of pressure and temperature at Lahore and Allahabad, which is very suggestive of the method to be adopted and the results to be used in a discussion from the second standpoint. The modifying influences of the orographic distribution are too considerable to admit of close connection between the results recorded and the general atmospheric circulation, and no attempt has been made to develop such connection.

¹ *Memoirs of the Indian Meteorological Department, being Occasional Discussions and Compilations of Meteorological Data relating to India and the Neighbouring Countries.* Published under the direction of Dr. G. T. Walker, F.R.S., Vol. xviii., part iii. V. A Discussion of the Anemographic Observations recorded at Allahabad from September, 1890, to August, 1904. VI. A Discussion of the Anemographic Observations recorded at Lucknow from June, 1878, to October, 1892. By Sir John Eliot, K.C.I.E., F.R.S. (London: Harrison and Sons, 1907.) Price 2 rupees.

Allahabad is situated about 300 feet above sea-level at the junction of the Ganges and Jumna, where their general direction is changing from E.S.E. to E. The plain of these rivers forms part of a great plain 1300 miles long and about 200 miles broad, in no part of which does the height above sea-level exceed 1000 feet. On the north it is bounded by the Himalayas, which change their direction from N.W. to W. in passing from the Punjab to Assam. Near Allahabad the direction is approximately W.N.W.

To the south the ground rises gradually to the plateau of Central India, across which runs a low range of hills from Bombay in an E.N.E. direction, passing about 150 miles south of Allahabad.

Allahabad is therefore near to the south edge of the flat bottom of a trough with sides converging towards the east, the south side being very slightly inclined and of small elevation compared with the north. Lucknow is 110 miles N.W. of Allahabad, and lies at the centre of the flat bottom. The motion of the air in such a trough is complicated, but the general result is that air flowing in or out transversely is deflected towards the right in its course, the effect being in both cases to produce motion parallel to the trough. On these motions will be superposed the effect of the general circulation of the atmosphere, which is both actually and theoretically westerly in the upper regions so long as the trough is definitely north of the thermal equator, becoming easterly when the thermal equatorial region includes the trough.

The exposure of the anemometer at Allahabad was excellent, but at Lucknow was not so good, and at the latter place the instrument, during the later years, was not kept in proper working order. It is probably partly due to these causes that the records from Lucknow show winds considerably weaker than those from Allahabad.

The results of the records have been arranged in tables giving for each month for each hourly interval of the day (1) the mean movement of the air, irrespective of direction; (2) the number of winds recorded under each octant of the compass; (3) the number of miles recorded under each octant of the compass; (4) the mean coordinates of the resultant wind movement.

For exhibiting the leading features of the air movement these results have been charted, and a series of carefully drawn plates is given at the end of the discussion. In addition to wind roses, showing the amount of wind in each direction and the proportion of calms, there is an excellent set of diagrams showing for each month of the year the diurnal variation of the air movement and the mean monthly resultant velocity. The diurnal variation bears no direct relation to the ordinary diurnal pressure variation.

For the purposes of discussion, Sir John Eliot divides the year into two periods, the dry season extending from the middle of October to the middle of June, and the wet season during the remaining four months. The dry season is further subdivided into the dry cool season, November to February, and the dry hot season, March, April, May.

During the cool season, pressure gradients are small, and the main feature of the distribution is the persistent continental high pressure. Locally, the isobar through Allahabad at 8 a.m. in January runs nearly through Lucknow in a N.W. direction, becoming more northerly as the day advances, while the wind changes its direction from W.N.W. to N.N.W. Thus there appears to be a correspondence between the wind direction and the local pressure gradients similar to that noted every day on the synchronous weather charts for temperate latitudes. The variations are, however, too rapid for the development of the full effect of the earth's rotation in producing an approach to parallelism between the isobars and the wind direction.

It is important in considering this rotation effect to remember that it acts as a modifying influence in conjunction with the pressure distribution, and although the latter is in the end the outcome of the air motion and temperature variation, there is nothing to warrant the assumption that the combined effect on air motion is to produce always a veering in the wind. Air starting from rest and moving across a permanent system of isobars will veer as it progresses, but a change in the direction

of the gradient may more than counteract this action of the earth's rotation.

Briefly, if the pressure fall in unit distance along two perpendicular straight lines, Ox , Oy , by amounts α , β , and if the resultant velocity due to the effects of the pressure gradient, friction, and the earth's rotation be proportional to the gradient and make a constant angle θ with the isobars, the components of velocity in the two directions Ox , Oy , will be $k(\alpha \cos \theta - \beta \sin \theta)$, $-k(\alpha \sin \theta + \beta \cos \theta)$.

If, now, α , β are the mean values of α , β deduced from mean pressure distribution, and if u , v are the mean values of the components of wind velocity, we find

$$\bar{u} = k(\alpha \cos \theta - \beta \sin \theta), \quad \bar{v} = -k(\alpha \sin \theta + \beta \cos \theta)$$

and the same relation, therefore, holds for mean values as for synchronous distributions. The angle θ depends on friction and on the time the motion has been in progress; u and v will therefore vary between limits depending on these factors. The general relation is, however, simple, and it appears desirable to test its applicability to motion in the large unbroken plain, ample and suitable data for which are furnished by the present series of memoirs.

An examination of the diagrams shows that at both Allahabad and Lucknow the cold season has the greatest percentage of calms and the smallest air movements. The latter are, however, steadier than at any other season. Calms are 2½ times more frequent at Lucknow than at Allahabad, the average number at the former place being 30 per cent. of the total number of observations. The mean direction of the air movement is slightly W. of N.W. at both places. The diurnal variations of magnitude are similar at both places, the maximum being reached about 3 p.m., when the average velocity is more than double that of the evening. The changes in direction at the two places are very different. The wind usually veers throughout the day at Allahabad, and backs during the night; at Lucknow the main feature is considerable backing from 11 a.m. to 3 p.m., and slow veering for the remainder of the day, with slight and very irregular movements at night, the changes being much less than those at Allahabad.

In the dry season the winds are of maximum intensity at Lucknow and of mean intensity at Allahabad. At both places the actual resultant air movement is a maximum for the year. The winds are relatively very steady in March and April, and very unsteady in May. The mean direction changes from N.W. to N. at Allahabad, and from W.N.W. to N.W. at Lucknow during the course of the season. The diurnal changes are similar to those of the cold season, but are more marked, and in May the changes in direction are greater at Lucknow than at Allahabad, but still take place in the reverse direction.

The winds during the wet season are remarkable for their increased variability in direction. The actual amplitude of the diurnal variation of magnitude is considerably less than for the dry season, the winds being less feeble during the night and of average intensity in the day. At Allahabad the mean direction of air movement in July is from W.S.W., but during the early morning hours it is nearly S., and at 4 p.m. it is N.W. by N. At Lucknow the mean direction is N.E., and the variations are less marked, but there is a very remarkable change from E. by N. to N.E. by N. between 10 a.m. and 11 a.m. The motion is the same as if the places were in a trough of ascending motion the axis of which moved towards Allahabad in the course of the day.

Diagrams are also drawn to show the variations of air movement along, and perpendicular to, the axis of the trough, appropriately called the axial and transverse variations. The axial variation shows similar features throughout the dry season. There is a fairly rapid increase in the daytime until 4 p.m., after which there is a rapid decrease. During the night there is practically no change. In the wet season the increase is much smaller at both places. At Allahabad the maximum is reached at 11 a.m., and the decrease takes place slowly during the remainder of the day. There is a feeble secondary maximum at 2 a.m. At Lucknow the increase takes place slowly and irregularly from midnight to midday, while there is a similar decrease until 10 p.m. The transverse variation is throughout markedly different at the two

stations. At Allahabad the northerly component *diminishes* during the dry season until midday, after which it increases until about 5 p.m., the epochs advancing two hours from November to April. At Lucknow the northerly component *increases* rapidly to a maximum at 11 a.m., and diminishes again to a minimum at 3 p.m., after which the changes are slow and irregular.

In the wet season there is an average increase in the northerly component at Allahabad from midnight until 4 p.m., and a corresponding decrease for the rest of the day. At Lucknow the main feature is a sudden increase in the northerly component between 10 a.m. and 11 a.m., after which there is a decrease with oscillations to the minimum at 10 a.m. on the following day, the rapid afternoon fall being absent.

These features of the transverse oscillation, together with the greater steadiness of the winds at Lucknow, appear to be partly due to its more central situation; but the backing of the wind during the day indicates that a longer period is necessary to produce the larger motion in the direction of the trough than is requisite for the smaller transverse variation. It is probable that for Allahabad the earlier transverse motion is modified by the effect of the Central Plateau; this effect diminishes in the afternoon, and is replaced by the influence of the Himalayas, which is, of course, weaker than at Lucknow. The nature of the transverse variation appears also to imply that the effect of the Himalaya range in constraining the air motion in the plain is actually produced dynamically through the medium of rotary motion transverse to itself rather than through a forcing of the stream lines to conform to parallelism with a rigid boundary.

The solution of the problems presented, and their connection with convective motion not shown directly by the winds, would be considerably advanced by a knowledge of the vertical temperature gradient in the free atmosphere over the plain.

A noteworthy feature is brought out in the auxiliary tables, representing the steadiness of the wind by the ratio of the resultant air movement to the total movement. The winds of the wet season are most steady near midnight, while in the dry season the epoch of maximum steadiness is about 4 p.m.

The accompanying tables exhibit the main features of the annual variation and the distribution of the wind.

so that either the suggestion of periodicity or the table needs readjustment.

The arrangement of the memoir is excellent, and it is full of suggestiveness to the student of meteorology. It forms a valuable contribution to our knowledge of Indian meteorology.

E. G.

MEDICAL INSPECTION IN LONDON.

DR. JAMES KERR, medical officer (education) to the London County Council, here adds another to the series of his admirable reports. These always contain much that cannot be neglected by the students of educational conditions, and this report is no exception. It consists of sixty-six pages crowded with new materials of the highest scientific and practical value. Administratively, probably the most important statement in the report is that "a point has now been reached, as to whether the greater part of the medical inspection shall remain fruitless, or whether the Council shall take steps which will justify its later interference to see that its younger dependents have a fair chance of benefiting properly by the education offered. Treatment as a public concern will have to be considered in respect to certain educational matters, such as visual troubles, discharging ears, ring-worm, and the care of the teeth, in which neither the private practitioner nor the hospitals can give hope of either providing sufficient or satisfactory relief for most of the cases requiring it" (p. 3). A composite committee has been appointed to inquire into this serious problem, on which the circular recently issued by the Board of Education has a definite bearing. The report of this committee will be looked for with interest alike by the hospitals and the practitioners.

The general results of the medical inspection confirm the work of previous years. The medical officers are now coming to closer quarters with the children, and this report contains many careful pieces of special research. These it is here possible only to indicate. Emphasis is laid on the urgency of the inspection of infants, especially of infants of three to five years of age. Tubercular bone and joint disease can then be most readily prevented. In inspection of the secondary schools and training colleges there was noticed a "general ignorance of how to expand

LUCKNOW

ALLAHABAD

Season	Month	Percentage amount of wind to total amount in each month from									Monthly percentage of wind	Percentage amount of wind to total amount in each month from									Monthly Percentage of wind
		N.	N.E.	E.	S.E.	S.	S.W.	W.	N.W.	N.		N.E.	E.	S.E.	S.	S.W.	W.	N.W.			
Dry	October	26.0	9.2	6.5	1.9	1.2	6.2	18.1	30.9	5.3	13.9	14.7	13.0	6.5	3.5	7.8	21.6	19.0	5.7		
	Nov. ...	30.3	8.2	1.9	1.7	0.9	5.5	21.3	30.2	3.9	15.2	11.0	10.6	6.4	2.7	5.1	25.7	23.4	4.3		
	Dec. ...	22.5	7.7	3.3	2.1	1.8	13.2	27.6	21.8	4.8	10.4	8.9	7.5	4.2	3.4	7.4	34.0	24.2	5.6		
	Jan. ...	19.0	7.3	6.9	3.6	2.8	10.6	25.5	24.3	6.3	8.8	11.8	15.0	3.9	2.2	8.2	32.2	17.9	6.9		
	February	22.4	7.3	4.1	2.6	1.9	8.4	25.7	27.6	8.4	7.2	10.4	16.8	6.4	2.8	8.0	33.0	20.4	7.2		
	March ...	16.3	5.9	3.3	4.1	3.5	11.6	30.8	24.5	11.6	10.4	13.6	6.7	3.3	2.3	6.4	34.6	22.8	9.4		
	April ...	16.8	9.1	4.2	2.0	3.9	10.8	26.0	27.2	12.1	12.7	14.4	6.9	4.6	5.0	7.9	28.0	20.2	9.1		
	May ...	12.6	10.2	15.7	6.0	4.1	9.0	22.2	20.2	11.1	15.0	16.2	16.5	9.1	5.0	4.6	16.4	18.2	10.8		
	June ...	13.9	14.0	20.3	7.2	5.5	9.4	14.6	15.1	11.2	9.1	18.2	21.5	9.1	7.1	9.3	14.6	11.1	11.8		
Wet	July ...	16.5	14.4	22.0	9.7	7.3	11.2	9.7	9.2	9.9	7.6	12.8	16.5	7.5	11.7	14.2	18.5	11.2	10.8		
	August	18.3	13.0	19.5	7.8	7.5	11.1	10.6	12.2	7.5	8.4	16.3	18.3	7.8	5.8	12.0	20.7	10.7	10.1		
	Sept. ...	17.4	15.8	16.6	6.3	3.0	7.3	15.6	18.0	7.9	10.9	17.5	17.5	8.9	4.6	11.4	18.7	10.5	8.3		
Year ...	18.0	10.4	11.2	4.9	4.0	9.8	20.7	21.0	10.0	10.6	14.3	14.2	6.6	5.2	8.8	23.8	16.5	10.0			

We note that the winds were taken from the records of Beckley's anemograph, but there appears to be no statement regarding the factor used in the reduction to miles per hour. In any case, the winds are comparatively feeble, the maximum recorded in any single hour being thirty-five miles at Lucknow and forty-five miles at Allahabad. There appears to be an inconsistency between the statement on p. 320 of the years of maximum and minimum movement and the table on the preceding page,

the thorax by deep inspiration" (p. 8). Among girls, "headaches were complained of by 20.5 per cent. . . . Exaggerated movements, corrugated foreheads, insomnia, and somnambulism were met with. Several cases of over-strain were specially reported" (p. 9). "The average standard of physique is low." There is a careful mathe-

1 London County Council. Report of the Education Committee of the London County Council submitting the Report of the Medical Officer (Education) for the year ended March 31, 1907.

mathematical study (pp. 10-16) by Dr. Shrubsole of the statistics of growth. The general results might with advantage have been further elaborated on the practical side. As to teeth, there is a strong plea for school dental clinics on the model of Strassburg.

A special investigation as to tuberculosis of the lungs in school children was undertaken by Dr. Squire and Dr. A. G. Gowdoy. Of actual phthisis, only 335 cases (i.e. 0.55 per cent.) were found among 58,934 children. The sections on hearing and acuity of vision contain much fresh material. One of the most important sections deals with the "development of articulatory capacity for consonantal sounds" (p. 27). Considerable detail is given of the methods of testing, and 105,000 tests were made on some 3000 children. The results are given in an exact quantitative way, capable of analytical study. This department is of immense importance to the teacher, as the work already done in phonetics has abundantly shown. As to fatigue, some new curves from rifle-shooting are given. It is found that the curve improves with a little practice, co-ordination improving very rapidly. Cigarette-smoking was found to impair the capacity to shoot straight.

There are the usual sections dealing with the inspection of defective children and cripples, country homes, infectious diseases, adenoids, &c.; but two sections must be specially named, one on the artificial lighting of school-rooms and the other on the mental and physical effects of bad ventilation. In both researches the practical results are very definite, and ought to be driven home among teachers and architects alike. Of the ventilation research, some provisional conclusions are:—"Temperatures above 65° F. give rise to definite subjective symptoms, slackness and inattention in some, headaches in others. Although it is not easy to assert definite mental alteration till about 70° F." "Symptoms do not appear at 65° if the air is kept in gentle movement by a fan in the room. With temperatures 70° F. and above, other factors being normal, there are marked symptoms and very evident deterioration in mental alertness and accuracy." At low temperatures, relative humidity does not affect the mental capacity of children, but increase of humidity increases the effects of high temperatures. Carbonic acid gas in considerable excess increases markedly the fatigue of the children. Exact details are given of the methods used.

The London County Council is to be congratulated on the issue of this mass of original and important observations in so many departments of medical inspection. Dr. Kerr's reports show the great educational possibilities of the system, which, under his guidance, has revealed many new regions for clinical and scientific research.

THEORY OF THE MIRAGE.

THE theory of the mirage forms the subject of several recent papers by Prof. Antonio Garbasso. In notes contributed to the *Atti dei Lincei*, xvi. (2), 1, 8, the author discusses the propagation of light in a heterogeneous medium, making use of the principle of least time, and considering the case of space of any number of dimensions defined by curvilinear coordinates. The space in question is supposed to be subject to the usual assumption that the square of the line-element is a homogeneous quadratic function of the differentials of the coordinates. As might be expected from the principle of least action (an analogy the applications of which to the problem are probably already known), the equations of the path can be reduced to the form of the ordinary equations of dynamics by a suitable choice of the characteristic function. The applications to the mirage itself are discussed in a paper in the *Memorie of the Turin Academy*, 1907. Prof. Garbasso aims that while the phenomenon has been studied both experimentally and theoretically, his present work fills a gap in the literature by establishing agreement of a qualitative character between the results of calculation and those of experiment.

Two kinds of mirage are distinguished, one due to the variations of density caused by diffusion between two fluids of different refrangibility initially having a plane of separation; this is called the mirage of Vince. The second kind, called the mirage of Monge, depends on

diffusion outwards from a plane boundary maintained indefinitely at the same conditions. The former condition gives three images, two direct and one inverted; the latter gives only the reflected image. Prof. Garbasso calculates the law of density from the equations of diffusion, and thus determines the equations of the trajectories of the rays of light and the form of the wave-front.

The final comparison with experiment is discussed in a paper by Luigi Rolla, also in the *Memorie of the Turin Academy*. In it the last-named author describes experiments showing how, not only has Wollaston's original artificial mirage of the Vince type been reproduced with its three images, but also the Monge mirage has been imitated, and in both cases the trajectories of the rays have been determined by observation and compared with results of theory. Moreover, a mirage with five images, observed by Parnell at Folkestone in 1860, was realised by placing over a layer of carbon bisulphide a mixture of equal parts by volume of alcohol and chloroform. Owing to the unequal rates of diffusion, the conditions give rise to five images, and this and other experiments are shown to be suitable for lecture-room demonstration.

By taking a block of gelatin containing a cavity filled with liquid which gradually diffuses into the gelatin, the corresponding images for a cylindrical or spherical distribution of density have been also produced and compared with the results of mathematical calculation.

The first and second figures show the mirages of a diaphragm somewhat in the shape of a ship produced by the medium formed by diffusion between alcohol and

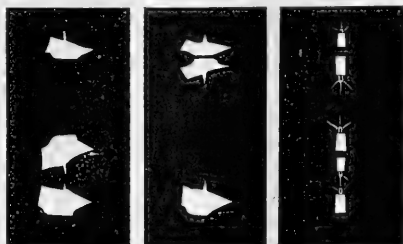

FIG. 1.

FIG. 2.

FIG. 3.

bisulphide of carbon. Fig. 1 represents the appearance after a few hours, Fig. 2 after several days. Fig. 3 shows the five images obtained by diffusion between bisulphide of carbon and a mixture of alcohol and chloroform.

G. H. B.

1 CONTRIBUTION TO THE HISTORY OF IRONCLADS.

LORD ROSSE has made an interesting contribution to the history of ironclads by placing at the service of the Institution of Naval Architects copies of letters written by his father to various distinguished men in the years 1854-5. From these letters it appears that the late Lord Rosse not merely appreciated the importance of armour protection against horizontal shell fire, but satisfied himself that it was possible by means of suitable proportions to secure ample stability in ironclad ships. Naval officers were then disposed to think that the "top-weight" inevitable with heavy loads of armour would make vessels unstable. Lord Rosse proposed the construction of ironclad floating batteries of moderate size; they were intended to fight in smooth water, and consequently were to carry their guns at a small height above water. The exposed sides were to be armoured with 5 inches of iron, and the upper decks to be covered with 2-inch plating.

In a letter to Sir John Burgoyne dated June 26, 1854, Lord Rosse proposed an armament of sixteen heavy guns; the draught of water was not to exceed 12 feet to 13 feet, and the vessel was estimated to be about 1500 tons. He

added:—"All this is the roughest possible, but I think if worked out in detail the result would not be widely different. The greatest care would, of course, be necessary to guard against submarine explosives." To this letter Sir John Burgoyne replied that he doubted whether 5 inches of iron would answer its intended purpose and make a vessel practically impregnable. In this connection he remarked:—"Iron is very treacherous, and breaks, bends, and tears under very irregular effort. The Navy have a thorough dislike to it for the sides of ships, but then they have never contemplated, I believe, such thick-

ness." These remarks from so high an authority on ordnance as Sir John Burgoyne throw an interesting light upon opinions prevailing little more than fifty years ago in regard to naval construction. Lord Rosse was not discouraged, but proceeded to press his scheme upon the attention of the Duke of Newcastle and on Sir Baldwin Walker, who was then Controller of the Navy. In his letter to the Duke of Newcastle, Lord Rosse stated that he "had been considering, no doubt in common with many others, in what way the great mechanical resources of England could be brought to bear against the mechanical resources of St. Petersburg." In this writing, Lord Rosse no doubt had in view the fact that ironclad floating batteries had been decided upon. Five such vessels were commenced in France in September, 1854, and later on similar vessels were built here, but not from Lord Rosse's outline design.

In the publication of those letters a filial duty has been fulfilled. The late Lord Rosse is shown to have been one of the first to make a definite proposal for the construction of ironclad floating batteries, and his treatment of the subject is worthy of his scientific reputation. On the other hand, it cannot be doubted that the action taken in France was independent of the suggestions of the late Lord Rosse. The correspondence with Sir John Burgoyne, the Duke of Newcastle and others could not have been known to the Emperor Napoleon when he took action; the construction of the French floating batteries was commenced about the same time as these letters were written, but was preceded by experimental trials made to determine the thickness of the armour to be adopted. It may be added that General Paixhans, to whom the introduction of horizontal shell-fire was due, had proposed the use of armour protection for ships about 1820, and Mr. Stevens began the construction of a floating battery near New York many years before the Crimean War took place. Lord Rosse obviously had no knowledge of these facts when he made the proposals above described, and acted quite independently.

THE SMITHSONIAN INSTITUTION.

THE report of the secretary of the Smithsonian Institution for the year ending June 30, 1907, has been received. It serves admirably to show the great part taken by the institution in American scientific life. Full particulars are provided, not only of the explorations and researches inaugurated by the institution, but also of the work of the U.S. National Museum, the Bureau of American Ethnology, the International Exchanges, the National Zoological Park, the Astrophysical Observatory, the Regional Bureau of the International Catalogue of Scientific Literature, and the excavations on the Casa Grande Reservation—all placed by Congress under the direction of the institution.

Reference has already been made from time to time in these pages to the researches prosecuted in connection with the institution, but it will be of interest to refer to a few which are summarised in the report. In connection with the study of the older sedimentary rocks of North America, on which Dr. Charles D. Walcott, the secretary of the institution, has been engaged during the past twenty years, upwards of 20,000 feet of strata have been carefully examined and measured. The Cambrian section has been found to include more than 12,000 feet of sandstones, shales, and limestones, and the Lower, Middle, and Upper Cambrian have been found represented in the section of Bow River series and the Castle Mountain group. Characteristic fossils have been found in each division.

NO. 1098, VOL. 77]

An expedition in April, 1907, to Alaska to collect the remains of large extinct vertebrates, particularly mammals, has already done good work. Dr. G. P. Merrill has examined the crater-form depression near Canyon Diablo, Arizona, to determine whether it was caused by explosive volcanic action or is due to the impact of a mass of meteoric iron; his observations are being collated and arranged.

In connection with the seismological investigations undertaken to compare the disturbance in Chile with that in California, it seems to have been determined that there has been some elevation of the coast of Chile, but no traces of a rift such as caused the earthquake at San Francisco. Numerous other researches were assisted during the year; these included the absolute measure of sound, the properties of matter at very low temperatures, the study of the upper air, the organs of flight, and others.

UNIVERSITY AND EDUCATIONAL INTELLIGENCE.

CAMBRIDGE.—The Council of the Senate recommends that the necessary steps be taken for altering Statute B, chapter vi., by the insertion of a paragraph giving the University power, upon the retirement of a professor, either at the date of his retirement or subsequently, to appoint him as a professor emeritus in the subject of the professorship previously held by him. A professor emeritus shall not as such receive any stipend, and shall be subject to no conditions as to duties or residence.

Dr. W. N. Shaw, of Emmanuel College, has been appointed to represent the University at the meeting of Imperial and colonial meteorologists, convened by the Royal Society of Canada, to be held at Ottawa in May.

Mr. J. S. Gardiner has been re-appointed demonstrator in animal morphology for five years as from October 1, 1907, and the appointment has been approved by the special board for biology and geology.

The special board for biology and geology reports that the Gordon Wigan income for biology and geology has been applied during 1907 as follows:—(a) a grant of 50*l.* a year to Dr. D. Sharp for a period of three years (1907-9), or such part of it during which he holds the curatorship in zoology; (b) a grant of 50*l.* a year for one year (1907) to Prof. Seward to enable the Botanic Gardens Syndicate to offer greater facilities for plant-breeding experiments; (c) a grant of 50*l.* out of the income for 1907 to Prof. Hughes, to enable Mr. E. A. N. Arber, of Trinity College, to continue his researches into the stratigraphical and geographical distribution of fossil plants.

LORD STANLEY OF ALDERLEY will distribute the prizes and certificates to evening students of the Battersea Polytechnic on Wednesday evening, February 19, and will deliver an address.

We learn from the *Pioneer Mail* that the Maharaja of Darbhanga has made a gift of nearly 17,000*l.* to the Lieutenant-Governor for the purpose of constructing a library building in connection with the Calcutta University.

The annual general meeting of the Association of Technical Institutions will be held on February 21 and 22 at the Drapers' Hall, Throgmorton Street, London. On the first day the association will be entertained at luncheon by the Drapers' Company, after which the new president, Sir Norman Lockyer, K.C.B., F.R.S., will deliver his presidential address. On the second day papers will be read on the best early training for a boy about to enter a technical institution or to take up a trade.

In a recent report, the Director of Education for the United Provinces has, in accordance with the orders of the Government of India, described the progress of education in his district during the last five years. An abridgment of the report in the *Pioneer Mail* states that the attendance at the Thomason Civil Engineering College at Roorkee has increased from 336 to 495, and various improvements in and extensions of the curriculum have been effected. An agricultural college has been opened at Cawnpore. It is hoped that the medical college at Lucknow will be in working order soon. The Thomason College will, it is

expected, shortly develop into a technological institute for engineering purposes, and a technological institute for chemical matters will be established at Cawnpore. Another matter of high importance referred to in the report is the change recently made with the object of introducing more practical work into the course for the degree of Bachelor of Science—a necessary step to meet the growing demand for good teaching in science, which is evidenced by the doubling, in five years, of the number of affiliated colleges preparing for science degrees, and a large increase in the number of undergraduates studying science.

SOCIETIES AND ACADEMIES.

LONDON.

Royal Society, December 12, 1907.—"On the Scattering of the β Rays from Uranium by Matter." By J. A. Crowther. Communicated by Prof. J. J. Thomson, F.R.S. The results of the experiments described are summarised as follows:—

(1) A parallel pencil of β rays is scattered in its passage through matter, the scattering being practically complete after the rays have traversed a thickness of material which varies from 0.015 cm. for aluminium to 0.0002 cm. for gold.

(2) The scattering, after correction for the loss of energy, due to the absorption of the rays may be represented by an equation of the form $I/I_0 = e^{-\sigma d}$, where d is the thickness of the material traversed by the rays, and σ is the coefficient of scattering for the rays, I_0 being the initial intensity of a narrow parallel pencil of β radiation, crossing a small fixed cross-section of the pencil, and I the intensity crossing the same cross-section when a thickness d of material is placed in the path of the beam at a considerable distance from the fixed cross-section.

(3) The ratio of the coefficient of scattering σ to the coefficient of absorption λ is approximately constant for all the substances measured, its average value being about 13. The values of the ratio σ/ρ , where ρ is the density, show similar variations to those for λ/ρ .

December 12, 1907.—"Preliminary Note on the Operational Invariants of a Binary Quantic." By Major P. A. MacMahon, F.R.S.

Mineralogical Society, January 21.—Prof. H. A. Miers, F.R.S., president, in the chair.—Zeolites from the neighbourhood of Belfast: F. N. A. Fleischmann. The author gave an account of a number of hitherto unrecorded zeolite localities near Belfast which he visited in November last. The localities described are quarries in the lower basalt of the neighbouring hills, the most important being two, the first situated on the north side of the hill, which is locally known as Cat Carne, the second on the north-east slopes of Collinward. The first quarry is the most prolific in zeolites in the neighbourhood, yielding fine specimens of apophyllite, analcite, chabazite, leynite, faerelite, &c. In the second quarry cavities are rare, but when they occur are, as a rule, large, and are usually lined with colourless tabular apophyllite crystals which reach sometimes an inch and a half across, and are associated with large hemispherical aggregates of natrolite.—Strüverite and its relation to ilmenorutile: Dr. G. T. Prior and Dr. F. Zambonini. The mineral was found in the pegmatite of Craveggia, N. Piedmont. In its crystallographic characters it is almost precisely similar to rutile, tapiolite, and ilmenorutile (F. Z.). Chemically (G. T. P.) it is closely related to ilmenorutile, and contains titanate, niobate, and tantalate acids with oxide of iron, in proportions corresponding approximately with the formula $Fe(TaNb)_2O_4 \cdot 4TiO_2$. At first it was thought to contain zirconia as an essential constituent; the supposed zirconia, however, was shown on further examination to consist of niobate and tantalate acids, which, after the fusion of the mineral with $KHSO_4$ and treatment with water, had passed into solution with the titanate acid. In the presence of as much titanate acid as occurs in strüverite (40 per cent.) it was found that the greater part of the niobate and tantalate acids could thus pass into solution, and when a dilute solution of sulphuric acid (5 per cent. H_2SO_4) was used instead of water in treating the melt obtained

with $KHSO_4$, the whole passed into solution. New analyses of ilmenorutile from the Ilmen Mountains and from Norway showed that the titanate acid has been previously much over-estimated, and is present, in the first case, only up to 53 per cent., and in the other to about 54.4 per cent. The mineral from the Ilmen Mountains was also found to contain tantalate acid up to about 15 per cent. The most reasonable view of the composition of these minerals appears to be that they are solid solutions of tetragonal rutile (TiO_2) with the crystallographically similar tetragonal niobate or tapiolite, $Fe(TaNb)_2O_4$. Twin structure: Dr. John W. Evans. The author adopts as a definition of a twin crystal that it is a crystal consisting of two component parts such that (a) parallel lines in general have not the same physical characters in the same direction in the two components; (b) one or more "twin-planes" exist such that all lines parallel to (1) any line in a twin-plane, or (2) the "twin-axis" normal to a twin-plane, have the same physical characters in the same or opposite directions in the two components. He shows that this definition includes all twins by reflection, rotation, or inversion (=reflection+rotation) and divides twin-axes into eleven classes according to the odd or even cyclic characters of the twin-axis, the relations between the terminations of the twin-axis, and the relations between the disposition in space of the structure of the two components. He describes twins as amphitetic, homothetic, or antithetic according as lines parallel to the twin-plane have in both components the same physical characters (1) in both directions; (2) in the same directions; or (3) in the opposite directions.—A simple method of drawing crystals of calcite and other rhombohedral crystals, and of deducing the relations of their symbols: Prof. W. J. Lewis. The author described a simple method of drawing crystals of calcite and other rhombohedral crystals, in which the principal axis and the twin-axis lie in the plane of the paper. The method is not well adapted for showing simple forms, but with combinations and twinned crystals the drawings closely resemble ordinary clinographic drawings, and are much more easily and rapidly constructed. The geometrical relations between the faces and the relations between the Millerian and Naumannian symbols are readily followed from these drawings. Some unusual twinned crystals of calcite were shown and described; one shows the form {917} twinned on {011}, and another {13.0.17} twinned on the same law.—The structure of perowskite from the Burgumer Alp, Pfitschthal, Tyrol: H. L. Bowman. The examination of the optical properties and etching figures of transparent cubic crystals from this locality confirms the interpretation of the structure of perowskite proposed by Baumhauer from the study of crystals from the Ural Mountains and from Zermatt. The crystals are mimetic, and belong to the orthorhombic system, the "cubes" being formed by a combination of basal pinacoid {001} and a prism {110} with an angle of 90°, and having a lamellated structure due to twinning about faces of {110} and {111}.

Geological Society, January 22.—Sir Archibald Geikie, K.C.B., Sec.R.S., president, in the chair.—The origin of the pillow-lava near Port Isaac in Cornwall: Clement Reid and Henry Dewey. The Upper Devonian strata around Port Isaac consist of marine slates, in which occurs a sheet of pillow-lava. The pillows measure usually from 2 feet to 5 feet in diameter, but range up to 8 feet. The individual pillows are disconnected. Their mutual relations seem to prove that they were soft when deposited. Each pillow shows internally a central vacant space or open sponge, succeeded by a thick shell of vesicular lava, followed by a shell of banded rock. The whole mass is so vesicular that it must have been very light. The association with fine-grained marine strata shows that this lava was probably submarine. The specific gravity of the whole mass must have been low, not greatly exceeding that of sea-water. The lava seems to have been blown out into thick-walled bubbles. The mass was for a time in the spheroidal state, and the sheet could flow like a liquid. This eruption seems to have been analogous to that of Mont Pelée, described by Dr. Tempest Anderson and Dr. Flett, except that it was submarine instead of subaerial.—The subdivision of the Chalk at Trimmingham (Norfolk): R. M. Brydson.

Royal Anthropological Institute, January 28—Annual meeting.—Prof. D. J. Cunningham, F.R.S., in the chair.—Anniversary address, anthropology, in the eighteenth century: Prof. Cunningham. The work of the period centres round five men, Camper, White, Blumenbach, Prichard, and Lawrence, of each of whom an interesting account was given.

MANCHESTER.

Literary and Philosophical Society, November 26, 1907.

—Prof. H. B. Dixon, F.R.S., president, in the chair.—Demonstration illustrating the formation of acetylene from elementary substances: Prof. E. Knecht. On heating a small piece of calcium on charcoal before the blow-pipe, the metal readily took fire, and, after burning with a brilliant orange flame for about two seconds, sank into the mass of the charcoal. After the latter had been allowed to cool, it was broken up, when a hard lump was found which yielded acetylene on treatment with water.—New reactions for the characterisation of mercerised cotton: J. Hübner. The author has found that, on immersing mercerised and ordinary cotton in a solution of iodine in saturated potassium iodide solution for a few seconds, and afterwards washing with water, the colour of the mercerised cotton quickly changes to a bluish-black, whilst the ordinary cotton becomes lighter in colour and changes to a brownish-chocolate shade. After further washing the ordinary cotton becomes white, whilst the mercerised material remains a bluish-black colour, which fades very slowly on prolonged washing.—The direct combination of carbon and hydrogen: H. F. Coward. In experiments made with small quantities of highly purified carbon, the author has obtained from 0.1 gram of carbon, containing a maximum of 0.9 c.c. of hydrogen, 100 c.c. to 120 c.c. of methane by direct union with hydrogen.

December 10, 1907.—Prof. H. B. Dixon, F.R.S., president, in the chair.—Some notes on the mammals of Lundy Island: T. A. Coward. The notes were the outcome of a few days spent in trapping on the island; some of the specimens obtained were exhibited.—Notes on some destructive mites: C. G. Hewitt. The author described a new mite, *Lohmannia insignis*, Berl., var. *dissimilis*, n. var., which was found feeding on the scale-leaves of tulip bulbs. Two other mites which have occurred in the Manchester district were described, viz. *Rhizoglyphus echinopus* and *Glycyphagus spinipes*.

January 14.—Prof. H. B. Dixon, F.R.S., president, in the chair.—The atomic weight of chlorine: Dr. E. C. Edgar. The method used to re-determine this constant was to burn pure dry chlorine, at the tip of a quartz jet, in an atmosphere of pure dry hydrogen in a quartz "combustion vessel"; the hydrogen chloride formed was condensed in a limb of it by liquid air. As the mean of eight experiments, the atomic weight of chlorine calculated from the ratio weight of chlorine burnt/weight of hydrogen burnt is 35.194; from the ratio weight of hydrogen chloride caught—weight of hydrogen burnt/weight of hydrogen burnt it is 35.193 (atomic weight of hydrogen=1). If the atomic weight of oxygen is taken as 16, that of chlorine becomes 35.462 and 35.461 respectively.—The production of photographs in the colours of nature: A. Brothers.

January 28.—Prof. H. Lamb, F.R.S., in the chair.—A new type of dynamical stability: A. Stephenson. A system in a position of equilibrium and capable of oscillation about that position may be acted on by periodic force in such a way that no oscillation is generated; thus the equilibrium of a pendulum is not disturbed by the action of vertical force. The object of the communication was to establish the remarkable property of this non-generating type of disturbance in maintaining an equilibrium which would otherwise be unstable.

PARIS.

Academy of Sciences, February 3.—M. A. Chauveau in the chair.—The existence of crystallised sodium fluoride as an element of the nepheline syenites of the Los Islands: A. Lacroix. These rock specimens were collected by M. Villiaume from Ruma. In order that unweathered material only should be obtained, the specimens were removed by blasting, with dynamite, and about half a ton of rock was brought to Paris. One syenite was found

to contain a new mineral, the mineralogical and physical characters of which are described in the present paper. It has a smaller refractive index ($n_D = 1.328$) than any other known mineral, and appears to consist of sodium fluoride, with traces of manganese, calcium, potassium, and possibly zirconia. The mineral is named villiaumite, and its mode of origin is discussed.—The heat of formation of the anhydrous oxides of strontium and barium: M. de Forcrand. Strontia and baryta cannot be purchased pure, but if the hydroxides are placed in a platinum boat and heated to 850° in a current of dry hydrogen, absolutely pure, white SrO and BaO can be obtained, the platinum boat not being attacked. The heats of solution found are higher than those of Thomsen, possibly on account of the greater purity of the material.—Observations of the sun made at the Observatory of Lyons during the third quarter of 1907: J. Guillaume. The results are summarised in three tables, giving the number of spots, their distribution in latitude, and the distribution of the faculae in latitude respectively.—The development of an arbitrary function according to the functions of Laplace: Léopold Fejér.—A new electric arc furnace applicable to laboratory researches: Louis Clerc and Adolphe Minot. For an E.M.F. of 50 or 60 volts, by suitably proportioning the area of cross-section of the furnace to the current, an arc of any length can be obtained. In the furnace figured, using from 1 to 2 kilowatts, any desired temperature from a dull red heat upwards can be obtained, and capable of dealing with from 2 to 40 grams of material.—The use of flames as valves for high-tension alternating currents: André Cathiard.—Some anomalous modifications of the band spectra of various compounds in the magnetic field: A. Dufour. M. Henri Becquerel has attributed the peculiar behaviour of the bands of calcium fluoride, previously described by the author, to the presence of impurities. This view would appear to be improbable, since similar phenomena are now shown to be exhibited by the chlorides and fluorides of all the alkaline earths.—The reduction of indigo by the electrolytic method: H. Chaumat. The method recently described by the author was anticipated by Goppelsröder in 1882.—Some complex salts of iron in which the iron is masked: P. Pascal. Recently precipitated ferric pyrophosphate is soluble in sodium pyrophosphate, the solubility being independent of the temperature and concentration of the sodium salt. When the solution is saturated, the constituents are in the proportion $Fe_2(P_2O_7)_3 : 3Na_2P_2O_7$, which may be written $Na_4Fe_2(P_2O_7)_3$, or sodium ferropyrophosphate comparable with the ferricyanide, and the behaviour of the salts, together with the isolation of the acid itself, confirm the view that such a complex acid exists.—Some new derivatives of camphenylene: its constitution: L. Bouveault and G. Blanc.—The order of addition of ammonia to organic α -oxides of asymmetrical structure: K. Krassousky. The reactions between ammonia and trimethylethylene oxide and isobutylene oxide have been studied, and the conclusion is drawn that in the combination of ammonia with asymmetrical α -oxides, the hydroxyl group is found attached to the carbon atom containing the least hydrogen.—The genesis of certain minerals of alumina and iron. Lateritic decomposition: Jean Chautard and Paul Lemoine.—The presence of scapolite gneiss and cipolin in Dahomey: Henry Hubert.—The origin of the fertile soils of western Morocco: Louis Gentil.—The solution of saccharose isotonic with the eggs of *Strongylocentrotus*: Jacques Loeb. The author contests that his experimental results are in strict agreement with those of M. Delage.—The morphology and evolution of the Sabellarians of Saint Joseph: Ch. Gravier.—Contribution to the study of the calorific solar radiation: C. Féry and G. Millochau. An account of work done in the observatory at the summit of Mont Blanc in 1907. The apparatus was standardised by pointing at an electric furnace, and gave an effective absolute temperature for the centre of the solar disc of 5555° C. The value found for this temperature in 1906 was 5620° C.

CALCUTTA.

Asiatic Society of Bengal, January 8.—Notes on Indian mathematics, ii., Aryabhata: G. R. Kaye. The most important part of this paper consists of a translation

of Aryabhata's "Ganita," and a comment thereon. These are prefaced by brief notes which explain the position occupied by Aryabhata in the history of mathematics. The point of view of the writer differs from that of those who have previously treated the subject in that he holds that it is beyond all doubt that Aryabhata's work owes its origin to the Alexandrian school of mathematicians. Aryabhata does not claim to be the discoverer of the rules he gives, and it is thought that the "Ganita" was intended by him to be supplementary to the mathematical knowledge of the Hindus of his time. The "Ganita" is examined in close detail, and abundantly confirms this hypothesis. The claims that have been made for Aryabhata—that he was the inventor of our modern system of arithmetical notation; that he discovered a more accurate value for π than any of his predecessors; that he was the first to give a systematic solution for indeterminate equations of the first degree—are shown to be unsound (see also p. 347).—Studies in experimental breeding of the Indian cottons: an introductory note: H. Martin Leake. Breeding experiments have been undertaken at Cawnpur, and the third generation has now been reached. As a result of numerous measurements of the leaf it has been found that if narrow-lobed and broad-lobed leaved plants be crossed, the proportions of the leaves in the first generation (F₁) approximate remarkably to the arithmetic mean of those of the two parents, and this appears to be true for all crosses, whether they be made between the extreme forms of *Gossypium neglectum* or between such divergent types as *G. arboreum* and *G. herbaceum*. In the F₂ generation of crosses, plants with typical broad and with typical narrow-lobed leaves appear, just as ascertained laws of heredity teach us to expect. From the way in which intermediates such as have been artificially raised occur naturally in the fields of the United Provinces of Agra and Oudh, it is apparent that cross-fertilisation is common. Further, in illustration it is cited that a packet of seed of *G. arboreum* taken without precautions yielded two out of fourteen plants the parentage of which was obviously impure, and which therefore stand as evidences of natural cross-fertilisation of *G. arboreum* by some other species of *Gossypium*.

DIARY OF SOCIETIES.

THURSDAY, FEBRUARY 13.

ROYAL SOCIETY, at 4.30.—The Constitution of the Electric Spark: T. Royds.—On the Determination of Viscosity at High Temperatures: Dr. C. E. Fawcitt.—The Effect of Hydrogen on the Discharge of Negative Electricity from Hot Platinum: Prof. H. A. Wilson, F.R.S.—The Decomposition of Ozone by Heat: Dr. E. P. Perman and R. H. Graves, ROYAL SOCIETY OF ARTS, at 4.30.—The New Imperial Gazetteer of India: R. Burn.

MATHEMATICAL SOCIETY, at 5.30.—Proof that every Algebraic Equation has a Root: Dr. H. A. de S. Pittard.—On the Uniform Approach of a Continuous Function to its Limit: Dr. W. H. Young.—Note on q -differences: Rev. F. H. Jackson.—An Extension of Eisenstein's Law of Reciprocity (Second Paper): A. E. Western.—Conformal Representation and the Transformation of the Plane: The Equator: E. Cunningham.

FRIDAY, FEBRUARY 14.

ROYAL INSTITUTION, at 9.—Biology and History: Dr. C. W. Saleeby. ROYAL ASTRONOMICAL SOCIETY, at 5.—Anniversary Meeting. PHYSICAL SOCIETY, at 8. MALACOLOGICAL SOCIETY, at 8.—Annual Meeting.—President's Address: Malacology versus Palaeoconchology: B. B. Woodward.

MONDAY, FEBRUARY 17.

ROYAL SOCIETY OF ARTS, at 8.—The Theory and Practice of Clock Making: H. H. Cubyngthame, C.B. VICTORIA INSTITUTE, at 4.30.—Philosophy and Evolution: Prof. H. L. Orchard.

TUESDAY, FEBRUARY 18.

ROYAL INSTITUTION, at 8.—Membranes: Their Structure, Uses and Products: Prof. William Stirling. ZOOLOGICAL SOCIETY, at 8.30. ROYAL STATISTICAL SOCIETY, at 5. INSTITUTION OF CIVIL ENGINEERS, at 8.—Shaft-sinking at the Horden Colliery, South-west Durham: J. J. Prest.—The New York Rapid-transit Subway: W. B. Parsons.

WEDNESDAY, FEBRUARY 19.

ZOOLOGICAL SOCIETY, at 8.—Notes on the River Wey: H. Bury. ROYAL MICROSCOPICAL SOCIETY, at 8.—Eyes pieces for the Microscope: J. M. Nelson.—The Life-history of a New Protozoite: Rev. Eustace C. Burt.—On Dimorphism in the Recent Foraminifer *Alveolina laevis*: T. C. Linn.—*Exhibits*: Slides illustrating the Life-history of some *Diplo-*, C. L. Curties.—An Improved Mercury-Vapour Lamp: J. E. ROYAL METEOROLOGICAL SOCIETY, at 7.30.—Formation of Snow Rollers: C. Brown.—Comparison of Ship's Barometer Readings with Those Deduced from Land Observations: E. Gold.

THURSDAY, FEBRUARY 20.

ROYAL SOCIETY, at 4.30.—*Probable Papers* 1.—Notes on the Application of Low Temperatures to some Chemical Problems: (1) Use of Charcoal in Vapour Density Determination. (2) Rotatory Power of Organic Substances: Sir James Dewar, F.R.S., and Dr. H. G. Jones.—On the Osmotic Pressure of Compressible Solutions of any Degree of Concentration. Part II. Cases in which both Solvent and Solute are Volatile: A. W. Porter.—Effects of Self-induction in an Iron Cylinder when traversed by Alternating Currents: Prof. Ernest Wilson.

ROYAL INSTITUTION, at 3.—Wood: Its Botanical and Technical Aspects: Prof. W. Somerville.

INSTITUTION OF MINING AND METALLURGY, at 8. LINNEAN SOCIETY, at 8.—Experiments with Wild Species of Tuber-bearing Solanums: A. W. Sutton.—The Life-history and Larval Habits of Tiger Beetles (Cicadele): Dr. V. E. Shelford.—On a Possible Case of Mimicry in the Common Sole: Dr. A. T. Masterman.—*Exhibit*: Stereoscopic Photographs of Alpine Plants in Natural Colours: T. Ernest Waltham.

INSTITUTION OF ELECTRICAL ENGINEERS, at 8.—Electrical Power in Railway Goods Warehouses: H. Henderson.—Electric Power in Docks: C. E. Taylor.

CHEMICAL SOCIETY, at 8.30.—The Action of Thionyl Chloride and of Phosphorus Pentachloride on the Methylene Ethers of Pyrocatechol Derivatives: G. Berger.—The Preparation of Conductivity Water: H. Hartley, N. P. Campbell and K. H. Poole.—Derivatives of *para*-Diaminobenzene: G. T. Morgan and Miss F. M. G. Micklethwait.—A Study of the Diaz-reaction in the Diphenyl Series: G. T. Morgan and Miss F. M. G. Micklethwait.—Organic Derivatives of Silicon. Part VI. The Optically Active Sulphobenzylthiopyrosilyl Oxides: F. S. Kipping.—A Simple Manometer for Vacuum Distillation: N. L. Gebhard.

FRIDAY, FEBRUARY 21.

ROYAL INSTITUTION, at 9.—The Ether of Space: Sir Oliver Lodge, F.R.S. INSTITUTION OF MECHANICAL ENGINEERS, at 8.—Annual Meeting. (1) A Low Steam Feed-water Heater: Prof. J. Goodman and D. B. MacLachlan.

CONTENTS.

	PAGE.
Is Mars Habitable? By Dr. William J. S. Lockyer	337
Agriculture in France	339
Chemistry in the Seventeenth Century. By W. A. D	339
Town Gas	340
Our Book Shelf:—	
Dudeney: "The Canterbury Puzzles and other Curious Problems"	341
Allan: "Matter and Intellect: A Reconciliation of Science and the Bible"	341
Brillouin: "Leçons sur la Viscosité des Liquides et des Gaz"	341
Huxley: "Aphorisms and Reflections"	341
Letters to the Editor:—	
The Inheritance of "Acquired" Characters.—Dr. G. Archdall Reid; Rev. E. C. Spicer; A. D. D	342
Atmospheric Electricity and Fog.—Dr. Charles Chree, F.R.S.	343
The Penetrating Radiation.—W. W. Strong	343
Classification of Secondary X-Radiators.—Dr. C. G. Barkia and C. A. Sadler	343
Auroral Characteristics of Clouds.—George C. Simpson	344
Reissner's Fibre in the Frog.—George E. Nicholls	344
<i>Rhynchobdella aculeata</i> in Ceylon.—Dr. Arthur Willey, F.R.S.	345
Poseidonius on the Originator of the Theory of Atoms.—Dr. T. J. J. See	345
Agricultural and Horticultural Research. (<i>Illustrated</i>) By R. N.	345
The Geology of the Transvaal. (<i>Illustrated</i>) By Dr. F. H. Hatch	346
The History of Arithmetical Notation. By G. B. M. Prof. J. B. Pettigrew, F.R.S. By W. C. M	348
W. A. Shenstone, F.R.S. By Prof. William. A Tilden, F.R.S.	348
Notes	349
Our Astronomical Column:—	
Occultations of Uranus in 1908	353
Observations of Comets 1907d and 1907e	353
Planets now Visible	353
Encke's Comet, 1908a	353
A Catalogue of Zodiacal Stars	353
Meteors observed on January 2	353
The Winds of Northern India. By E. G	353
Medical Inspection in London	355
Theory of the Mirage. (<i>Illustrated</i>) By G. H. B	356
A Contribution to the History of Ironclads	356
The Smithsonian Institution	357
University and Educational Intelligence	357
Societies and Academies	358
Diary of Societies	360

THURSDAY, FEBRUARY 20, 1908.

CONTINUATION SCHOOLS.

Continuation Schools in England and Elsewhere.

Edited by Prof. M. E. Sadler. Pp. xxvi+779. (Manchester: University Press, 1907.) Price 8s. 6d. net.

PROF. SADLER and his fellow-workers are to be congratulated on the production of a volume which is full of useful information and contains many valuable suggestions and expressions of opinion; moreover, it appears at a time when precise information of the kind given is urgently needed by educational authorities, merchants, manufacturers, workpeople, and teachers. For at the present moment two problems stand in urgent need of solution, and with both of them this volume is largely concerned. The first is how to meet the grave difficulty occasioned by the enormous development of machinery, which, though a good in itself, has brought in its train a grave loss, viz. the almost entire disappearance of the old apprenticeship system, which involved the careful training of the craftsman by his employer; and the second is how to deal with the large number of children who are employed as unskilled labourers at comparatively high rates of pay during their early years, who are subsequently replaced by similar children, and are then thrown on the labour market as unskilled labourers for whom there is not an adequate demand, and who go to swell the ranks of the unemployed.

Prof. Sadler and his colleagues give an account of the agencies which seek to solve these problems in this country and abroad, and of the legislative and administrative measures which we and other nations have adopted in order to cope with these difficulties. They show that, in so far as Great Britain is concerned, our success has only been partial, and, while giving full credit to all the improvements we have effected, they point out in what respects other nations are in advance of us; they instance, for example, the people's high schools in Denmark, and the enormous service they have done to the Danish nation, more particularly in so far as they have educated the agricultural population, and, *inter alia*, made possible cooperation among farmers, thus bringing about numerous improvements in Danish agriculture and conditions of rural prosperity which one would like to see in this country.

It is impossible to touch on all the various questions which the authors discuss; but there are four points which seem of more importance than the rest. In the first place there is the question of the "half-timer," which is dealt with by Mr. Sandiford in chapter ix., and by Prof. Sadler in the following chapter, which gives details as to the laws in regard to the employment of children in this country, Germany, and Switzerland. The evidence on both sides of the question is given in an impartial manner, and few unprejudiced persons will read it without being convinced that the continuation of the half-time system involves grave injustice to a not inconsiderable proportion of the

child population of Lancashire and Yorkshire; for it is clearly shown that the mental, moral, and physical condition of the average half-timer is seriously injured by the large amount of overwork to which he is subjected. It is painful to read that these wretched children are awakened by the "knocker-up" between 4.45 and 5.30 a.m., that with short intervals for food they work until 12.30 p.m., and are then expected to learn something in the two and a-half hours which they spend in school in the afternoon. The result of this cruel treatment can readily be imagined; careful measurements have shown that the average half-time scholar between the ages of thirteen and fourteen is an inch less in height, and weighs more than 2 lb. less than the average full-time scholar of the same age. Moreover, the damage is not merely physical; we are told that the half-timers are undoubtedly duller than the full-time children, and that they rise less frequently to good positions in their industry.

Clear evidence is adduced to prove that the employment of half-timers is by no means necessary, as there are many successful mills in which no such persons are employed; it is to be hoped, therefore, that Parliament will soon awaken to this crying evil, and will absolutely forbid employment of this kind, which is sanctioned in scarcely any other civilised country in Europe.

The second question, concerning which this book provides valuable information, is the need for the improvement and development of our public elementary schools in directions likely to give a better preparation for industrial life in the case of boys, and domestic life in the case of girls. In the past, and to a large extent at the present time, the schemes of education set forth by the Board of Education have been devised, and their working inspected, mainly by persons trained on classical lines in the great public schools and at the older universities; the result has been that our elementary education has taken directions which are too bookish and not of a sufficiently practical character; if anyone doubts this, he need only examine, as a sample, the absurd questions in arithmetic set by the Board of Education for the so-called "Labour Certificate." As a consequence, our elementary schools have tended to encourage unduly the production of clerks, and to spread amongst the poorer classes the idea that manual labour is less honourable than clerical work. Experiments are being made to counteract this, experiments, unfortunately, in some cases, not too cordially assisted by the Board of Education.

In chapters xiii. and xiv. an account is given of certain trade schools and pre-apprenticeship schools, which shows the attempts that are being made to combine ordinary elementary instruction with the attainment of a reasonable amount of manual skill. The very few hours a week at present given to such work in our elementary schools are grossly inadequate, and a much better result would be obtained if boys between the ages of twelve and fourteen were allowed to devote a considerably larger fraction of their school time to practical training of a suitable character; and if, during the same period, girls were given a know-

ledge of domestic subjects much more substantial than the smattering which they now get in the very short periods devoted to this essential part of their education. The experiments in this direction which have been tried in Gloucestershire have shown that, while the amount of book knowledge which the children possess may be somewhat smaller, the larger amount of contact they have had with *things*, as distinguished from mere *words*, makes them, on the average, not less, but more intelligent.

In the third place, one of the collaborators, Mr. G. L. Bruce, deals in the third chapter with evening schools in London, and mentions incidentally the great drawbacks to evening work of a university character, which are unfortunately imposed by the new teaching university itself (see pp. 132 and 138). There is no doubt much truth in this complaint, and, if a consideration of the question leads us to be careful that, in the foundation and working of our newer universities, we do not hand over technical training too largely to the control of those whose experience in this kind of work is either wanting or small, we shall have learnt a good lesson. The most successful technical colleges in the world are probably the Technical High School at Charlottenburg (Berlin) and the Massachusetts Institute of Technology at Boston; neither of them is subordinate to an ordinary university, though in each case a flourishing university exists side by side in the same town. Both of them have the right to give degrees, but the basis on which these degrees shall be offered is determined by those primarily interested in technical education; this is by no means always the case in our English universities.

Lastly, the most important matter dealt with in the book is probably the problem as to whether or not the State ought to make compulsory further attendance in continuation schools after a child has left a public elementary school; and if so, whether it should require employers to offer facilities for such attendance so that the child can continue its education without undue pressure. The attitude taken by Prof. Sadler in regard to this matter is one which will commend itself to most thinking persons; he asks for no rapid or revolutionary change, but he indicates clearly that the time has come when a step should be made in the direction taken by our most successful Continental competitors; for he states:—

"I am convinced that in the end some form of compulsion to attend day or evening continuation classes between fourteen and seventeen years of age will be found desirable, not so much in the interest of the picked individuals as in that of the rank and file. Many of the present evils of unemployment may be traced to the lack of educational care and of suitable technical training during the critical years of adolescence. Compulsion, however, should be accompanied by reduction in the hours of juvenile and adolescent labour where those are now excessive."

A careful perusal of the facts and statistics given in this book ought to convince our legislators that a move forward should now be made. It is a well-known fact that many of the students attending our evening continuation classes are so tired when they arrive there that only very poor work can be obtained, or indeed

expected, from them. No such classes are held in Prussia after 8 p.m.; many of them in this country only commence at this hour. Some wise employers (unfortunately comparatively few in number) allow their young people time in which to improve themselves, and so to become more useful citizens and better servants, but this practice is hardly likely to become general unless the State intervenes; that the employer and the nation would benefit in the end few can doubt.

No Government in this country is likely to attempt to deal with a matter of this kind until compelled to do so by public opinion. The volume under review should prove a powerful agency in stimulating the rapid growth of a healthy view of the matter; we therefore cordially congratulate Prof. Sadler on having once more taken a leading part in hastening an important educational and social reform.

J. WERTHEIMER.

ICELAND PAST AND PRESENT.

Island in Vergangenheit und Gegenwart. By Paul Herrman. Erster Teil, Land und Leute. Pp. xii. + 376. Zweiter Teil, Reisebericht. Pp. vi + 316. (Leipzig: W. Engelmann, 1907.) Price, 2 vols., 15 marks.

THIS is an account of travel in Iceland in the summer of 1904 by a German schoolmaster. He made the journey in exceptionally favourable circumstances, for, in addition to four months' leave for the special purpose, and a Reise stipendium, the municipal authorities of Torgau provided a *locum tenens* at the gymnasium during his absence; while in Iceland he had the services of the guide who accompanied Thoroddsen on seventeen of his eighteen journeys.

A lover of Iceland and an ardent student of the mythology and folk-lore of northern lands, Herr Herrmann is rather inclined to dwell on the different parts of the country in their aspect as the scenes of this or that Saga. But beyond this, his observation is keen and thorough. Though the book claims to be "not a geological or geographical, but a popular work," we learn incidentally of the geology, geography, natural history, and botany of those parts of the island visited.

The work is divided into two volumes, the first dealing with "Land and People," the second being a full account of three months on the route along the south and east coasts, from Reykjavik to Akureyri. If the book is to be regarded as a "popular" work, it would be advisable to read vol. ii. first. Then, having gained from the detailed description of the journey through the most populous and typical parts of the country a clear idea of the land and its inhabitants, the reader can better follow vol. i., which deals with the land and people generally, and assumes some knowledge of them.

The voyage from Copenhagen to Reykjavik is described, mentioning, *en passant*, Edinburgh, the Orkneys and Shetlands, and the islands south of Iceland, with their myriad sea-bird life. From Reykjavik a trial expedition to Hvalfjörður, Reykholt, and Thingvellir was undertaken to prove the travellers' fitness for the longer distance along the south and

east coasts, a route, travelled now for the first time by a German, that includes the passage of many dangerous glacial rivers.

In vol. ii. is the account of the principal journey. The party, consisting of the author, his guide, and a student from Torgau, left Reykjavik, passed again Thingvellir, and the Geysir district, and made the ascent of Hekla. Then across the Ranga to Oddi Storfshvöll and the many scenes of the Gunnarr Saga, Bergthorshvöll—of the Njáll Saga—to Vestur and Austur Skaptafells Sysla—the most difficult part of the journey; it is here that the coast is so dangerous, and so many fishing smacks are wrecked. The inhabitants of this district have but little communication with centres of civilisation, and have preserved the ancient characteristics almost unchanged. The travellers then continued through the Mula Sysla (Sudur and Nordur), and Thingeyjar Sysla (Nordur and Sudur), to Akureyri.

Every part traversed is minutely described; there is a good deal of scientific matter for the lay reader; and here it may be remarked that the author has an irritating habit of interspersing his reading matter with references—in addition to the many footnotes—and of placing the Icelandic of so many words in italics and parenthesis. This is a great hindrance to easy reading, especially as the same translation is given many times as the word recurs, and items of information are often repeated.

Vol. i. deals with Iceland's geological origin and formation, its volcanoes and glaciers, its geographical exploration, and traces its history from the earliest colonisation in the ninth century, as a free State, under Norwegian and Danish government, to the present day's self-government under the Danish flag.

The study and practice of medicine, the system of education, which is praised as perhaps the best in the world's history, the language and literature, are all considered, as are the ancient and modern industries and arts—wood-carving, embroidery, sculpture, painting, music, and the drama.

Much space is devoted to agriculture, and eighteen pages treat exclusively of sheep. The varied efforts of the State to encourage the farmers to obtain practical knowledge and to provide schools for their training and assistance are noted. The fishing industry also receives State help, and many statistics of this important branch are given. Much is made of the piracy of foreign fishing boats in Icelandic waters, English trawlers being specially attacked. But the author seems to have a prejudice against everything English; the British tourist is unmercifully criticised, and his manners, clothes, and food unfavourably compared with those of the German traveller. The one of our countrymen who joined the party for a short time must have been a very bad example of his kind, or there is another side to the story, which is given—as all else in the book—in detail.

The descriptions of Reykjavik and Akureyri are very full and explicit, and during his visit Herr Herrmann made the acquaintance of many Icelanders, and so gained, at first hand, information regarding the hospitals, schools, and many public and private social institutions and customs.

He sees everything generally *couleur de rose*, and prophesies a bright future for the island, expressing, nevertheless, the fear that the people, who, more than any other nation, have through centuries of civilisation preserved their ancient manners and customs, their pure language and literature, will, with their advance, lose in primitive charm. He urges philologists, while there is yet time, to make a thorough study of Icelandic.

We can hope, with Herr Herrmann, that he may add later a third volume to his book, dealing with the other parts of the island. If, at times, the personal element is too obtrusive, still the book leaves a very clear idea of Iceland, land and people, past and present, a result due partly to the many and excellent photographs, and numerous references, with which the author fortifies or supplements his own observations.

M. G. B.

ADVANCED ORGANIC CHEMISTRY.

Organic Chemistry for Advanced Students. By Prof. J. B. Cohen. Pp. viii+632. (London: Edward Arnold, 1907.) Price 21s. net.

THERE are several very excellent text-books upon the subject of organic chemistry in the English language, but although these meet the wants of the average student, the want of a more comprehensive book has been long felt. The book before us is intended to supply this want, and to a certain extent it undoubtedly will do so. The book, according to the author, is a series of essays prepared from notes of lectures delivered to senior students. The work is perhaps best described as being a series of monographs upon different branches of chemistry; as a consequence certain subjects have been exhaustively dealt with, and other subjects have been entirely ignored. Some students will therefore find all they require within the covers of the book, and others will search in vain for the branch of chemistry with which they are familiar or desire to become familiar. Of course, a book written in this manner is bound to a certain extent to lack sequence, and one has practically to commence *de novo* with each section of the book, that is to say, every section has its own historical introduction. For example, the first chapter is a more or less general introduction, but when we come to chapter ii., dealing with isomerism and stereoisomerism, there is again a long historical introduction. We are not objecting to the author treating the subjects historically; in fact, it is probably best to deal with each branch in this manner in order that the student may get a thorough and comprehensive grasp of the subject. This method of introducing and showing the gradual development of the subject is more likely to stimulate originality than the simple setting forth of a number of cut-and-dried facts.

There is, of course, a danger in treating organic chemistry in the form of a series of monographs dealing with different branches, because of a tendency to detachment and to an unnecessary division of the subject. But in giving a series of lectures to advanced classes in organic chemistry, there is practically no other way open than thoroughly to exhaust certain

branches, although at the same time it is well to connect and coordinate the groups as far as possible, just as examples in inorganic chemistry can often be made use of to elucidate certain facts in organic chemistry and *vice versa*.

Chapter ii., upon isomerism and stereoisomerism, is written in a very interesting manner, and the subject can be made anything but interesting. The diagrams are good, and the explanations clear and not too overloaded with details. This chapter deals with isomerism of the lactic acids, van't Hoff's and Le Bel's theories, mutarotation, &c., and the different action of dissolved substances, depending upon whether they are electrolytes or non-electrolytes. Certain of the sections, indeed, were it not for the full references, might be considered rather short. The next chapter treats of the stereochemistry of unsaturated and cyclic compounds (geometrical isomerism), and chapter iv. with the stereochemistry of nitrogen. The work of Pope and collaborators upon the optical activity of sulphur, selenium, and tin compounds is also included in this chapter, and also that of Kipping upon silicon compounds. It would certainly have been advantageous if this part of the section had been a little more fully gone into.

One of the best chapters in the book is that upon condensation. Here the various methods employed for condensations are elaborated and brought together in a manner which will be found extremely useful to students of chemistry and even to those who may consider themselves beyond the student stage. Not only are the methods themselves given, but the subject is also treated theoretically, as, for example, in the acetoacetic ester condensation and in Perkin's reaction. Another chapter is devoted to fermentation and enzyme action, which includes, beside an historical introduction, references to hydrolysis, oxidases, reductases, and the mechanism of enzyme action. The alkaloids, terpenes, camphors, proteins, and carbohydrates are dealt with in detail, but not colouring matters, either natural or artificial. Of course, the author does not pretend to cover all the branches of chemistry, and presumably his reason for omitting the colouring matters is that there is a special chair of chemistry dealing with this subject at the University of Leeds, and there are also other books on this theme.

As we have already stated, the book supplies a want, and we have pleasure in recommending it to all advanced students of chemistry; certainly all chemical libraries will require it.

F. M. P.

OUR BOOK SHELF.

The Geology of the Leicestershire and South Derbyshire Coalfield. By C. Fox-Strangways. Pp. vi+373. (London: His Majesty's Stationery Office, 1907.) Price 6s.

This latest memoir contains a description of the joint coalfields of Leicestershire and South Derbyshire, commonly known as the Leicestershire coalfield. It is one of the smallest coalfields of the Midland counties, and is cut off from the Warwickshire and Derbyshire coalfields by an uplift of older strata. It includes an area of about sixty square miles in Leicestershire, and about sixteen square miles in South

Derbyshire. Its exact limit has, however, not yet been proved. A large portion of the area is covered by Triassic rocks, so that the Coal-measures only come to the surface over twenty-four square miles. Although one of the smallest coalfields, it is one of the most ancient, having been worked to some extent from time immemorial. The earliest mention of coals being worked in the district is in the reign of King John in 1204.

The author describes the Coal-measures and the surrounding strata as far as it is possible from the evidence afforded up to the present time. He gives full particulars with regard to the productive measures, remarks on their probable extent beyond present workings, and a general account of the physical history and structure of the area. Brief accounts are also given of the associated rocks, including those of Charnwood Forest, of the Carboniferous Limestone and shales, of the Millstone Grit, and of the Permian and Triassic. A chapter is also devoted to the superficial geology. The water supply, saline springs, pottery clays, whinstone, ironstone, building stone, and lime are touched upon in a chapter on the economic geology of the area.

The final chapter on the palæontology of the coalfield has been written by Mr. A. R. Horwood, of the Leicester Museum, who has made a special study of the subject.

There are three appendices—(1) a glossary of technical or local mining terms, (2) a bibliography extending from Camden's "Britannia" of 1607 down to publications in 1907, and (3) details of all the borings and pit sections accessible, covering 200 pages. Many of these sections were left in manuscript by the late Rev. W. Coleman many years ago, and it is gratifying to find the records of old workings, that would probably otherwise have been lost, thus preserved. The bibliography is very valuable and complete. In the list of authors, by an oversight, the titles of Sir William Fairbairn and Sir Arthur Rücker have been omitted. Sir C. Le Neve Foster's title, omitted in the index, is given correctly in the list of authors preceding the bibliography.

The value of the report is greatly enhanced by a small coloured map of the coalfield and six large folding plates of vertical and longitudinal sections.

Inorganic Chemistry. By E. J. Lewis. Pp. xxv+408. (Cambridge: University Press, 1907.) Price 5s. This book, primarily intended for school use, deserves the widest recommendation as a sound and interesting introduction to the subject. It consists of a series of chapters or lessons in which the systematic part of the subject is happily blended with a considerable amount of theory. The treatment is thorough and painstaking without being dry. One is a little surprised, perhaps, after reading of the intended scope and purpose of the work, at the very large number of topics introduced which by tradition have come to be regarded as part of an advanced course. Thus, in part ii., the successive topics treated theoretically are mass action, thermochemistry, basicity of acids, relative strength of acids and bases, isomorphism, osmotic pressure, ionic theory of solution, and the periodic classification. The treatment, though simple, is satisfactory.

For the small number to whom chemistry is to become a life-study, there may be two opinions as to the wisdom of this brief inclusion at an early stage of so many topics of the advanced course, since thereby the latter is apt to be robbed of some of its freshness and novelty, and to lose in consequence its stimulus for the expanding intellect. But in so far as the course of instruction is intended to apply to

those, the vast proportion, who will have no subsequent regular instruction in the subject, the method and mode of treatment of the author may be heartily commended. It is, we learn, the outcome of actual class work, modified by experience and the mutual play of the minds of teacher and taught. The author has a belief in the especial value of "outdoor chemistry" as appealing to the interests of the learner, and there is an excellent chapter towards the end on plant respiration and nutrition.

One notices a few important omissions and errors. The use of the spectroscope in chemistry is nowhere alluded to. The mention of argon and its companions in the air should be amplified or omitted. As it is, it contains one of the few mistakes, in the statement that the density of argon is forty times that of hydrogen. Helium is not even referred to by name, surely a remarkable omission for an author addicted to "outdoor chemistry." We read, "The exact specific gravity of oxygen . . . is 15.88 ($H=1$). This makes the atomic weight of oxygen 15.88. . . ." But these few blemishes in no way detract from the general accuracy of the treatment.

It is a pleasure to notice a book of this description, for it indicates the serious and important place chemistry is taking in the school curriculum. It deserves a high place, not only in the school, but generally as an excellent introductory first course, understanding by this term not a mere smattering of the kind deemed sufficient only a few years ago, but a course in keeping with the true position of the science as a serious and profitable part of a good modern education.

Altitude Tables. Computed for Intervals of Four Minutes between the Parallels of Latitude 31° and 60° and Parallels of Declination of 0° and 24° , designed for the Determination of the Position Line at all Hour Angles without Logarithmic Computation. By F. Ball. Pp. xxxii+241. (London: J. D. Potter, 1907.) Price 15s. net.

The main purpose of these tables is to facilitate the determination of the position line from an observation of any heavenly body and to eliminate, practically, the chance of errors of computation in the result. When the idea occurred to the Rev. F. Ball he consulted the Astronomer Royal, who consented to the employment of several of the Greenwich computers on the work, under the direction of Mr. Crommelin; the accuracy of the tables is therefore beyond suspicion. The tables are computed for intervals of every four minutes between latitudes 31° and 60° and parallels of declination 0° and 24° , and they enable the observer to determine the position line at all hour angles without having to solve any spherical triangle. This does away with the necessity for logarithmic computations, and so the probability of errors is eliminated. For altitudes less than 70° it is expected that the tables will give results accurate within $12''$; for greater altitudes their use is not recommended. The author hopes soon to publish a companion volume for latitudes 0° to 30° .

Problems in Strength of Materials. By Dr. William Kent Shephard. Pp. vii+70. (London: Ginn and Co., n.d.) Price 6s.

Whittaker's Arithmetic of Electrical Engineering for Technical Students and Engineers. Pp. vii+159. (London: Whittaker and Co., n.d.) Price 1s. net.

To set students of applied science to work numerical problems involving thought in their subject is a good test as to whether they understand the principles involved. It is customary in many classes to associate the laboratory and lecture work with practice in

solving such problems, and teachers will find in these volumes many examples suitable for the purpose. The first volume, in addition to 568 exercises, contains some useful tables, but little in the way of worked-out examples to guide the student is given and no answers are provided. The second book, on the other hand, contains seventy-two typical problems fully solved, and a set of answers.

An Essay upon Disease: its Cause and Prevention. By Dr. G. E. Richmond. Pp. 96. (London: H. K. Lewis, 1907.) Price 2s. net.

The main object of Dr. Richmond's little book is to point out the large number of diseases either spread by food or directly due to impurities in food or articles in common use. It is surprising to find a confession in the preface to the effect that "the essay has been written rather hurriedly," and unfortunate that no index is provided.

LETTERS TO THE EDITOR.

[The Editor does not hold himself responsible for opinions expressed by his correspondents. Neither can he undertake to return, or to correspond with the writers of, rejected manuscripts intended for this or any other part of NATURE. No notice is taken of anonymous communications.]

Radium and the Earth's Heat.

It has been shown by the Hon. R. J. Strutt and other investigators that the materials composing the surface of the earth contain on the average about 10^{-12} gram of radium per gram, while about one-twentieth of this amount is sufficient to account for the heat lost by the interior of the earth by conduction. Mr. Strutt has therefore suggested that the interior of the earth contains less radium per gram than the surface. It is interesting to calculate what would happen if the whole earth contained 10^{-12} gram of radium per gram. If the specific heat of the interior of the earth is taken to be 0.1, and 1 gram of radium is supposed to generate 100 calories per hour, then it is easy to show that the temperature of the interior of the earth would rise by 10^{-3} degree C. per year if all the heat generated by the radium were used up in raising the temperature.

If the temperature of the interior rose 100° C., it is probable that the rise near the surface would be too small to be detected, so that observations extending over at least ten million years would probably be necessary to detect the effect of the heat generated by radium even if the whole earth contained 10^{-12} gram of radium per gram and all the heat generated went to raise the temperature.

I understand that geologists are inclined to think that the temperature near the surface of the earth has not altered much for many million years, but this is not inconsistent with a rise of 10^{-3} degree C. per year in the interior. It is, of course, quite possible that the specific heat of the earth is considerably greater than 0.1. The high pressure in the interior probably makes the specific heat larger than at the surface.

HAROLD A. WILSON.

I MENTIONED the possibility which Prof. Wilson discusses in my original communication on radium in the earth's crust in the Royal Society's Proceedings; but he certainly shows that it is more worthy of attention than I then thought it.

On this theory it becomes necessary to suppose that the primary stock of radio-active material in the earth—uranium—has not been in existence for a longer time than is required for the attainment of thermal equilibrium by conduction, for we know that the uranium is wasting away, and unless the supply is replenished it is clear that the gradient of temperature must diminish, instead of increasing as Prof. Wilson supposes. We cannot at present form any notion as to how the uranium could come into existence, so that any further development of the idea

would have too little contact with ascertained fact to be of much value.

I will take this opportunity of mentioning an alternative theory, which has the advantage of being amenable to experimental test. If we suppose that the rate of transformation of uranium is much diminished by increase of temperature, the quantity of radium and of all the other products will be diminished too, and with it the general rate of heat production inside the earth.

The effect of heat on radium and its products has no direct bearing on the problem. Everything is governed by the primary slow transformation—that of uranium.

There is no experimental evidence on this question so far as I am aware. It could probably be best attacked by comparing the ratio of formation of uranium X at various temperatures. The amount of uranium X which had grown in the course of a few days could be determined by β -ray measurements, which might be made after cooling.

R. J. STRUTT.

Sunnyside, Cambridge, February 13.

Ground Ice.

I SEE in your issue of January 30, p. 295, a letter from the Rev. John J. Hampson asking some questions on the subject of ground ice. I should like to say that my father, the late Prof. James Thomson, read a paper on this subject at the Natural History and Philosophical Society of Belfast on May 7, 1862, and I think his paper answers most of the questions. Thus he writes, after reviewing and setting aside several older theories:—"My own view is that the crystals of ice are frozen from the water at any part of the depth of the stream: whether the top, the middle, or the bottom, where cold may be introduced, either by contact or radiation; and that they may also be supplied in part by snow or otherwise: and that they are whirled about in currents and eddies until they come in contact with some fixed objects to which they can adhere, and which may perhaps be rocks or stones or may be pieces of ice accidentally jammed in crevices of the rocks or stones: or may be ground ice already grown from such a beginning.

"That pieces of ice under water have the property of adhering to one another with a continually increasing firmness, and this even when the surrounding water is above the freezing temperature, has been shown in a set of very interesting experiments by Prof. Faraday. I think too that the ready adhesion to the bottom, or to ice already anchored there, may possibly be increased by the effects of radiation, but I am confident that the anchor ice is not formed by crystallisation at the place where it is found adhering."

This paper has never been printed *in extenso*, but I hope soon to bring it out in a volume of collected papers written by my father.

JAMES THOMSON.

22 Wentworth Place, Newcastle-on-Tyne,
February 11.

The Stresses in Masonry Dams.

MR. MARTIN at first asserted that my reasoning was wrong on some general principle which I failed to grasp, whereas he has now fallen back on the order of the approximation, and appeals to what he terms an axiom of practical mathematics, which he illustrates by the statement that between σ and π a parabola can be found "differing but little from $\sin x$." If by the method of least squares a parabola be fitted to $\sin x$, it will be found to differ by more than 30 per cent. from the ordinate of $\sin x$ when $x=5^\circ$; whether that difference is material or not depends entirely on what use is to be served by the correspondence.

In the memoir which has led to this controversy I showed that the equation for the stress function V , i.e. $\nabla^2 V = 0$, was the same for a thin slab and an actual dam. Since writing the paper I noticed that the third equation for the stresses was apparently not the same.

I saw that this is only in appearance, for the terms

of thin plates can be properly used in dam experiments, for thin plates buckle and require a side support which destroys accuracy of experimental result. Even Messrs. Wilson and Gore's plates were at the toe as thick as they were broad.

which have a coefficient involving different functions of Poisson's ratio for the two cases are

$$\left(\frac{d^2}{ax^2} + \frac{d^2}{ay^2} \right) (\hat{u} + \hat{v} + \hat{w})$$

and I find that this vanishes by means of the differential equation for V . Hence, as I stated in my memoir, thin plates can be used to find experimentally the stresses. Mr. Martin is therefore quite correct in his views on this point, although I cannot still agree with his demonstration of the principle.

There are, however, far more vital criticisms to be made of the memoirs recently read before the Institution of Civil Engineers than the mere question of whether the stresses in a slab and an indefinitely long dam differ by 10 per cent. or 20 per cent. A very little experimenting will suffice to show that dams when they collapse go by stretching, and partly at points where there may be no tension at all. The strains measured by Messrs. Gore and Wilson are not those in a real dam at all, and if we now accept the view that the stresses are the same, then we must ask Mr. Martin to allow that their stretches differ by 30 per cent. from those in an actual dam.

It was this point which I endeavoured to bring out in the criticism of the paper to which Mr. Martin has referred. If their strains correspond to those of a real dam, then their stresses differ widely; if their stresses are correct, then their strains, upon which ultimately rupture depends, will be very different from those of the actual dam. I must leave Mr. Martin to choose his own horn of the dilemma.

Again, there is another point which is physically very obvious. If a dam, reservoir empty, were split up by a series of vertical divisions parallel to its length, each plate would be of different height, and compressed under its own weight would be subjected to a different squeeze at the base of the dam. To bring these vertical sheets into contact at the correct points it is needful to suppose shear over the vertical planes at the base of the dam. In other words, there must be a distribution of shear over the base of the dam due solely to its own weight. Since the total shear over the base is zero, this distribution of shear, if the extremity of the toes be vertical, must take some such form as is shown in the diagram. Our experi-

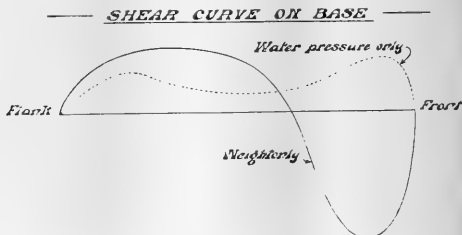

ments at University College showed that this base shear due to the weight of the dam only was as important as, and probably more important than, the distribution of shear due to the water pressure.

There is no evidence at all that I can see in Sir John W. Ottley and Dr. Brightmore's recent paper that they have paid attention to this point. They speak of the "original vertical lines on the model," and of measuring the displacement of these lines from "vertical lines on the glass." They speak of the return of the vertical lines on the model to the vertical lines on the glass on the removal of the water pressure. It would appear, therefore, that they have only measured the slide due to water pressure. But to deduce the stresses in the dam they must have the total shear, that due to the weight as well as that due to water pressure. I can find no evidence in their paper of any determination of the shear due to the weight of the dam. They say that the shear along the base is uniformly distributed. This, as Mr. Pollard and I showed in our memoir of last July, is roughly, but only roughly,

true, if we confine our attention to water pressure. It is not true, and the base shear actually changes its sign, if the weight of the dam be taken into account as it must be. That there is no tension in dams of the Assuan and Vyrny types in the outer toe we showed in our memoir, but there is stretch, and on this final rupture in part depends. The existence of this stretch is also indicated, although not referred to, in the measurements of displacement given by Sir John Ottley and Dr. Brightmore. I may have misinterpreted these authors' mode of experimenting, but I can find no evidence in their paper of the manner in which they deduced the shear due to weight only, and without this knowledge I venture to think that the whole of the superstructure they base on a uniform distribution of shear fails to find any adequate foundation.

KARL PEARSON.

University College, London, W.C.

The Inheritance of "Acquired" Characters.

I AM loth to take part in barren controversy on this subject again, but I feel it is really necessary to say a few words in reply to the letter of "A. D. D." in NATURE of February 13. When that gentleman refers to the slightly dogmatic tone of his original article he is not doing himself justice; the article was as dogmatic as it could possibly be. Now he asserts that there is no sense in the distinction between acquired characters and innate ones with regard to inheritance, that all characters are both acquired and innate. This in the accepted meaning of the words is simply untrue. If a man takes a summer holiday and becomes sunburnt, the colour of his skin is an acquired character; a negro's colour develops without exposure to the sun; he is brown (not black) when he is born; that is an innate character. The supernumerary toe in a Dorking fowl is an innate character; it is not acquired in the accepted sense of that word. Acquired characters are those changes in the individual which are due to a change of external conditions, i.e. of stimuli; innate characters are those which develop without any stimulus, except what Dr. Reid calls the stimulus of nutrition.

When Dr. Reid says that a scar on the nose due to injury is as much innate as the nose itself he is merely quibbling; he means, I suppose, that the scar could not be formed if there was not an innate power of producing a scar in healing a wound. But the only important point is that the scar is the consequence of a wound as well as of the innate qualities; the nose is the consequence of innate qualities only. "A. D. D." appeals to Dr. Reid, but Dr. Reid has most distinctly recognised the distinction which "A. D. D." denies. They may be left to neutralise each other.

J. T. CUNNINGHAM.

Technical Research and the College System.

SINCE I made the proposal, some time ago (*Chem. News*, vol. xxxix., p. 2, and vol. xl., p. 230), that research boards should be instituted in our technical colleges, with the object of supplying the college departments with subject-matter for research of a more or less technical nature, and at the same time of keeping in touch with the old students, I have had the opportunity of discussing the matter with men who occupy important posts in the technical world. They generally hold the opinion that some such scheme is urgently needed.

Many observations are made in works and works' laboratories which for several reasons cannot be properly investigated within the factory, but are yet admirably adapted to serve as subjects for scientific investigation in the laboratories of our technical colleges. Research of such a character would be not only of real educational value to the students, but serve a special purpose in giving useful preliminary training in the investigation of problems such as they are likely to encounter in real life.

The attitude of teachers in our colleges towards such questions has been recently stated by Dr. M. O. Forster. He acknowledged that, as a teacher, it became more and more clear to him that professors ought to be educated in technology. As I previously pointed out, the suggestion, which he again brings to the front, that manufacturers should supply problems for the consideration of young chemists in the college, is one which can hardly be met

in practice. The suggestion that manufacturers should supply raw materials for such trials is one that could easily be dealt with through ordinary channels if, and when, the subject-matter for research was available.

The suggestion that members of the college staff should enter the technical world for a time may be open to objection. Dr. Nichols, perhaps rightly, says that they could only return and "bring back to the students, and re-hush to them, what was daily becoming obsolete." On the other hand, they would undoubtedly benefit from contact with the outside world, especially in acquiring broader ideas and in realising the way in which constant development occurs in technical processes.

I think it may be held that there is no training in our technical colleges, taken as a whole, which can compare with that given in the medical schools. Here the students actually come in contact with the work they will ultimately be engaged on in their daily routine, viz. the study of abnormal cases. Even in the departments of our more recently built colleges, which are almost small factories in their way, these necessary conditions are in the majority of cases still absent. The course simply deals with the routine work of the factory, as represented by everyday operations. This is equivalent to supplying medical students with a set of perfectly healthy men for examination, an example which well illustrates the point under consideration, for in both cases the students go out into the world to engage in actual practice. Medical men trained on these lines would hardly be tolerated by the public, yet the manufacturer is expected to receive students so trained with open arms.

To meet the conditions obtaining in the technical world, I have proposed that in every college of standing there should be constituted a research board composed of members of the staff, with possibly a few old students as advisory members.

Past students would have the opportunity to submit to these boards subject-matter for research arising out of their actual observations, and of such a nature that it can be freely investigated in a college laboratory by picked students, working under the supervision of the board. The results, if satisfactory, would be published under the names of the old and present students from the college address.

In this way colleges would be supplied with the subject-matter now so urgently needed, and the old students would be kept in touch with their college in the best possible way.

The college staff would at the same time be relieved to a great extent from the burden of supplying subject-matter of a semi-technical nature, which, to be of real value, can only be suggested by those who are acquainted with modern technical problems.

The results of some such scheme might form the basis for grants from the Government in aid of research, and also supply a rough means of testing the comparative value of the training of the colleges.

I venture to put this matter forward for discussion. It is vitally necessary that a link between the colleges in this country, and the technical world should be found. On this point everyone is agreed. I fancy that some such link may be found in the above scheme.

Occasional lectures by old students who have specialised should be given at intervals during the session with the object of interesting students in modern technical developments.

Such points as these might be brought forward, in a more prominent way, by a federation of old students' associations, which should accomplish good work in many directions.

W. P. DREAPER.

Quilter Road, Felixstowe.

A Variation in *Amœba*.

WHILE looking at some *Amœba proteus* received from Mr. Thomas Bolton, I noticed a condition of the protoplasm of several specimens which I cannot remember to have seen before. The ectosarc was deeply striated, the lines extending some distance into the endosarc, wherever pseudopodia were not being put forth. On the formation of the latter the striae disappeared, but again became

visible if the pseudopodia were withdrawn. Perhaps some reader of NATURE who has studied these protozoa may be able to tell me whether these striæ are commonly met with (in which case lack of power of observation has caused me previously to overlook them), or whether they may be pathological, resulting from some debility in the organism. Certainly the Amœbæ in which I noticed the striated protoplasm seemed to be as lively as any without it. Like all those whose business it is to teach elementary biology, I have examined hundreds of Amœbæ, but to-day for the first time I saw the condition described. No text-book in my possession refers to or figures it. I shall be happy to send a drawing to anyone who may wish.

Eton College, February 12. M. D. HILL.

An Alleged Originator of the Theory of Atoms.

Mochus of Sidon, the alleged precursor of Demokritus, is not so unknown to historians of science as Prof. See seems to think (February 13, p. 345), nor is Strabo the only ancient writer who alludes to him; see, for instance, Josephus, "Antiquities," i., 3, 9. But nobody takes him seriously. The book of Mochus is one of the numerous literary forgeries which appeared in Alexandrian times. So far as I can find, it is not mentioned by any of the doxographic writers, so it is probably not much older than the time of Posidonius.

J. L. E. DREYER.

Armagh Observatory.

NOTES ON ANCIENT BRITISH MONUMENTS.¹

V.—Avenues (continued).

SO far I have not referred to the avenues at Shap. Mr. Lewis, in a memoir "on the past and present condition of certain rude stone monuments in Westmorland,"² gives extracts from several authorities showing that in the long past these avenues were not inferior to any in Britain.

Thus Camden (middle of the sixteenth century) writes:—"Several huge stones of a pyramidal form, some of them 9 feet high and 4 feet thick, standing in a row for near a mile, at an equal distance, which seem to have been erected in memory of some transaction there which by length of time is lost." Dr. Stukeley, writing about the middle of the last century, says:—"At the south side of the town of Shap we saw the beginning of a great Celtic avenue on a green common; this avenue is 70 feet broad, composed of very large stones set at equal intervals; it seems to be closed at this end, which is on an eminence and near a long flattish barrow with stone works upon it, hence it proceeds northward to the town, which intercepts the continuation of it and was the occasion of its ruin, for many of the stones are put under the foundations of walls and houses, being pushed by machines they call a 'betty,' or blown up with gunpowder; . . . houses and fields lie across the track of this avenue, and some of the houses lie in the enclosure; it ascends a hill, crosses the common road to Penrith, and so goes into the cornfields on the other side of the way westward, where some stones are left standing, one particularly remarkable, called the 'Guggleby' stone . . . I guess by the celebrity and number of the stones remaining there must have been 200 on a side" (he says the interval between the stones was 35 feet, which would give about 7000 feet, or nearly a mile and a third, or, allowing for the thickness of the stones themselves, a mile and a half, as the length of the avenue); "near them in several places are remains of circles to be seen of stones set on end, but there are no quantity of barrows about the place, which I wonder at." Gough, in his edition of Camden (1806), says:—"At the south end of the

¹Time I from p. 251.

²Ant. topological Institute, November, 1885.

³See chains S.W. of St. Michael's church. It is about 8 feet high of a cone-like or conical shape, placed upright with the heavy end uppermost. (⁴ Ordnance surveyor's note.)

village, on the common near the road-side [on the east side thereof] is an area upwards of half-a-mile long and between 20 and 30 yards broad, of small stones; and parallel to the road begins a double row of immense granites, 3 or 4 yards diameter, and 8, 10, or 12 yards asunder, crossed at the end by another row, all placed at some distance from each other. This alley extended within memory over a mile quite through the village, since removed to clear the ground; the space between the lines at the south-east end is 80 feet, but near Shap only 50, so that they probably met at last in a point. At the upper end is a circle of the like stones 18 feet diameter." This description is evidently taken by Gough from the "History and Antiquities of the Counties of Westmorland and Cumberland," by Joseph Nicolson, Esq., and Richard Burn, LL.D. (London, 1777), an extract from which has been obligingly communicated to me by Col. Hellard, R.E., the director of the Ordnance Survey, and from which the remark enclosed in square brackets has been taken.

Mr. Lewis informs us that "Camden also mentioned an ebbing and flowing well, which Gough said was lost, and that its peculiarity was purely fortuitous; still it might have been used for the advantage of the priesthood who probably set up the stones. . . . From the descriptions already quoted it would seem that the avenue ran northerly or slightly north-westerly."

With such assiduity were these memorials of the past removed that when the Ordnance survey was made the final examiner recorded in the parish name-book for Shap (1858):—"No one person in the parish of Shap can point out the site of the old avenue of granite stones, or can tell whether the small spot well known as 'Karl Lofts' is the S. or N. end of the Monument. It is most likely the N. end, as about $\frac{1}{2}$ a mile S. is a portion of a circle still to be seen, composed of huge granite boulders, and which probably is the southern turning of the Avenue. It would appear to have been preserved in Doctor Burn's time, but except 2 or 3 boulders, itself and all recollection of it, have faded from Shap."

In spite of this, I think it has been possible to make out the position and direction of the avenues from the few stones shown on the Ordnance 25-inch maps which Col. Hellard has been good enough to send me. Taking the stones of which at least three are in the same straight line, we get two avenues crossing to the E. of the turnpike and to the south of the village, as stated in the preceding descriptions. As measured on the 25-inch Ordnance sheet, the azimuths are S. 19° E. and S. 40° E. From measurements of the contours on the 1-inch map, the elevation of the horizon is about 1° 10' in each case.

These data give us declinations 32° 32' S. and 25° 54' S. respectively.

In bringing together the information available about avenues, I have been greatly struck by the existence of several with an orientation of S. 20°-30° E. The first of this series which I came across, on the ground, were those at Challacombe, an imposing monument once consisting of eight rows of stones with an orientation of N. 23° 27' W., or S. 23° 27' E. ("Stonehenge," p. 158). The rows might have been used in the south-east direction to observe the rising of a southern star; on the other hand, in the north-west direction, they might have been aligned on the setting of Arcturus, warning the summer solstice sunrise in 1860 B.C.

As this data was near to those suggested by the

¹ About 47 chains S. by E. of St. Michael's church.

other Cornish and Devon monuments, I thought the north-west use was more probable for these avenues and other less imposing ones on Shovel Down with nearly the same direction.

The more recent inquiries, however, suggest that in this I was wrong. In the first place, the evidence now afforded by Mr. Falcon regarding the Assacombe avenue shows that, like those at Merrivale, the look-out to the rising-place was up hill. Again, as at Merrivale, oriented to the rising of the Pleiades, the western end has two large monoliths, ending the two lines of stones, and a single sighting stone at the eastern end is placed *between* the lines.

Now these are the conditions at Challacombe if we assume a south-east use; the view is up hill, and the directing stone is at the eastern end.

I next proceed to give a list of the avenues at present known to me which are roughly parallel with those at Challacombe, and where, possibly, southern stars were in question; curiously enough, this condi-

tion applies to the Kennet avenue at Avebury, and to those at Borobridge and Shap.

tion applies to the Kennet avenue at Avebury, and to those at Borobridge and Shap.

Challacombe, Dartmoor, lat. 50° 36' N.

S. 23° 37' E., horizon 4° 48', dec. 31° 7' S.

Avebury, Wiltshire, lat. 51° 30' N.

S. 32° E., horizon 49', dec. 31° 34' N.

Borobridge, Yorkshire, lat. 54° 6' N.

S. 25° E., horizon 1°, dec. 32° 15' S.

Shovel Down, Dartmoor, lat. 50° 39' N.

S. 25° E., horizon 0° 46', dec. 34° 46' S.

(Other alignments at S. 22° E. and S. 28° E.)

Shap, Westmorland, lat. 54° 33' N.

Direction of avenue S. 19° E., horizon 1° 10', dec. 32° 32' S.

Crug yr Avan Avenue, S. Wales, lat. 51° 40' N.

S. 23° E. and S. 24° E., sea horizon.

With regard to this last avenue, the Rev. J. Griffith informs me that the "stone of honour" ("directing stone"), now recumbent, is at the southern end, and that the land rises in that direction; it would have been on the sky-line as seen from the north end of the avenue.

It is as well to point out at once that some of the monuments included in the above list are the most remarkable in Britain. Challacombe is the only multiple avenue that I have seen in these islands which approaches those in Brittany. The south-east avenue at Avebury was, I take it, the most important feature at one time of that elaborate temple; while, again, the stupendous stones which I think are the remains of an avenue at Borobridge are among the largest mono-

liths in Britain. The remains at Shap I have not seen, but an avenue nearly a mile long and 70 feet broad, according to Camden and Stukeley, is certainly out of the common.

What, then, might have been the use of these avenues? If they were erected to indicate the rising place of a southern star, the only important one they could have dealt with was α Centauri, and that between B.C. 3000 and B.C. 4000. I give approximate dates where the measures are sufficient to enable me to do so.

Challacombe	D.c.	31° 7' S.	... 3600 B.C.
Avebury	31° 34'	... 3500
Borobridge	32° 15'	... 3400
Shap	32° 32'	... 3400
Shovel Down	34° 46'	... 2900
Crug yr Avan	36° 00'	... 2700

Now if we take 3500 B.C., that is some thousand years before the time I have suggested to be indicated by the stellar alignments connected with the Cornish

circles. This raises several interesting questions. Why have we circles in Cornwall and practically no avenues? Why have we avenues practically without circles in Brittany?

Was there a swarm of avenue builders who preceded the swarm that built circles?

In this connection it is worthy of notice that in my "Dawn of Astronomy" I made out that there is a series of Egyptian temples oriented to α

Centauri, one of them being the Memnonia at Thebes; and long avenues, generally of sphinxes, were associated with all these temples, while circles were unknown.

Another point is connected with the rise of the star and its use as a warner.

The rise of α Centauri would be preceded shortly by that of β , almost in the same azimuth.

At the time in question, 3500 B.C., they would serve as warners for the November sunrise, which was long afterwards accepted as the beginning of the year by the Celts.

Further, at the dates in question there were no first-magnitude stars rising near the north point of the horizon, as Arcturus and Capella did afterwards, by which the lapse of time during the night might be measured.

The two stars in the Centaur might have been used in this way, but their usefulness would be much restricted owing to the short time they would remain above the horizon.

It is well to note that while the nearly southerly avenue is accompanied at Avebury by a May-year alignment, the second avenue at Shap seems to have been a solstitial one, the sunrise at the Winter solstice being in question. This, however, cannot be considered certain until local observations of the height of the horizon have been made.

Mr. Goddard (NATURE, February 6) has raised objections to my statements concerning the Avebury



FIG. 16.—The Avenue and Circle at Callernish.

Photo. by Prof. Thorpe.

avenues on the ground that in some of the old descriptions, given while many more stones were standing, some are indicated placed in relation to the road passing through the southern part of the bank, as it exists at present, and quite out of the line of the Kennet avenue indicated by the stones shown on the Ordnance map. If the stones once near the road were associated with those shown on the Ordnance map, there would be no avenue at all in the sense I have always used that word in these notes, but a twisty road having no possible astronomical significance, and, I may add, no resemblance to the Beckhampton avenue, of which all the recorded stones are in the same straight line, as near as I can now say; or to any of the others in the table I have given above.

It may be, indeed, that Stukeley was led into his snake theory by attempting to marry these two sets of stones, for he sees a snake even at Calernish, the perfectly straight avenue of which fortunately remains.

"I saw another at Shap, in Westmorland. . . . There is another, as I take it, at Classeness, a village in the island of Lewis between Scotland and Ireland. I took a drawing of it from Mr. Lwydd's travels; but he was a very bad designer. . . . a part of the snake remains going from it, which he calls an avenue. He did not discern the curve of it any more than that of Kennet avenue which he also has drawn in the same collection as a straight line."¹

If the conclusions I have expressed above be confirmed, namely, that Avebury was a going concern a thousand years before anything that now remains of Stonehenge was set up in its present position, or the avenues laid out, the use of the Kennet avenue to watch the rise of α Centauri as a warner of the November festival (while the sunrise in May was provided for in the Beckhampton avenue) ceased at least 4000 years ago. There has been ample time, therefore, to build the bank, to leave openings for wheeled traffic and to set up stones in many places. Indeed, the stones may have been removed from the avenue when the bank was built. That the bank came long after Avebury was first in use was, I take it, well known to Stukeley, as the following extract shows:—

¹ Stukeley, "Avebury," p. 62.

"When Lord Stowell, who owned the manor of Abury, level'd the vallum on that side of the town next the church, where the barn now stands, the workmen came to the original surface of the ground, which was easily discernible by a black stratum of mold upon the chalk. Here they found large quantities of bucks' horns . . . there were very many burnt bones among them. They were the remains of sacrifices."¹

Mr. Goddard does not seem to have read my previous notes carefully. I never imagined the Kennet avenue going "over the bank and ditch," but going to the southern circle *before the mound was built*, as the Beckhampton went to the other, as a *via sacra*, throughout the whole length of which the rising star could be seen. Of course, the existence of the bank

*Alignements orthogonaux de Leuré
(Canton de Crozon)
L = 48°16'N. - G = 6°50'5" N.
Echelle : 2 m. pour 1 m.*

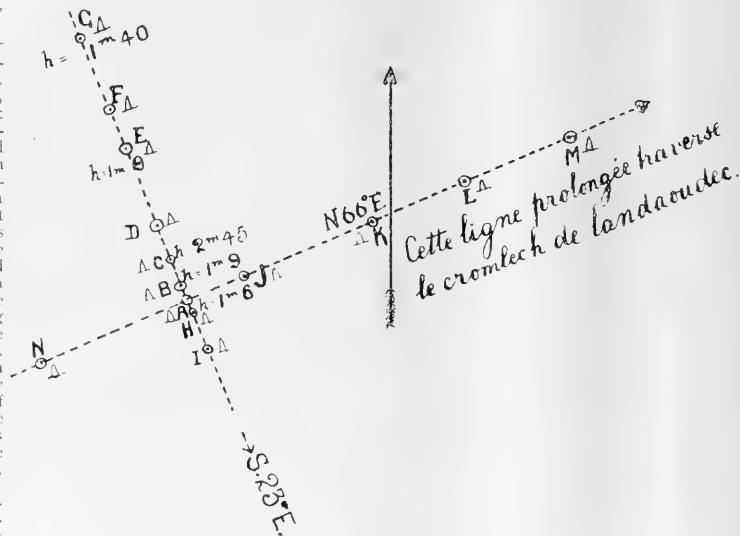

FIG. 17.—The alignments at Leuré from Captain Devo's observations.

would have prevented any star rise being seen from the circle along the southern horizon, and what often happened in Egypt suggests that the bank was built because the avenue had become useless.

That the Kennet avenue was once used as a *via sacra* to observe the rise of α Centauri as the morning star warner of the November sunrise is all the more probable since the avenue from the southern end of the Kennet avenue to the "sanctuary" was an alignment to the November sunrise itself so far as can now be made out.

Since writing the above I have received from Captain Devo, of the French Navy, some admirable surveys of several of the Brittany monuments. In one

¹ Stukeley, "Avebury," p. 27.

at Leuré we have two avenues, one S. 23° E. and another N. 66° E. (Fig. 17), avenues therefore practically parallel to the two at Aycbury, and doubtless used for the same purposes.

NORMAN LOCKYER.

A STUDY OF THE RIVER TRENT.¹

THIS little book is a clearly written popular account, in part amplified, and in part—rather unfortunately, we think—abbreviated, of the author's presidential address to the Lincolnshire Naturalists' Union. It deals with the geological structure and history of the Lindsey division of Lincolnshire, especially in relation to the vicissitudes, actual or supposed, of the river Trent.

The author is not the first, nor is he likely to be the last, to try conclusions with the intricate story of the Lincoln Gap, that sharp and sudden breach through the escarpment of the Lower Oolites by

are devoted to an exposition of Prof. Davis's work, and his very convenient terminology is explained with all necessary clearness, though the general reader for whom the book is written will no doubt be puzzled by the reference without the necessary definition to a "penplain."

The author attributes over-much of the levelling of the great plains of the Jurassic clays to the Trent, and seems to imply that while these valleys were in process of formation the escarpments by which they are bounded stood where we now see them, a confusion which he shares with many recent writers, who fail to recognise that escarpments are incessantly receding. On the other hand, it is satisfactory to find that he takes due account of the possibility that the Trent may have been captured by the Humber drainage in pre-Glacial times, have been restored to its primeval course through the Lincoln Gap in consequence of an ice-barrier across the Humber, and again in post-Glacial times re-captured by the Humber



Photo.

The Ægir, Gainsborough, October 12, 1904. Showing the after-waves, locally called "The Whelps." From "The Shaping of the Lindsey and Trent."

E. W. Carter, Gainsborough.

which the little strike-river, the Witham, abruptly doubles across into the fenlands of the Oxford, Amphill, and Kimeridge clays, and so reaches the Wash.

Since the publication in 1862 of Jukes's epoch-marking paper on the river valleys of the south of Ireland, in which the cardinal principle of river-capture was enunciated, the Trent and its anomalous course has furnished a theme and an illustration to writers on our British rivers. Ramsey used it, Mr. Jukes Browne added much additional evidence and gave greater definiteness to our conceptions of the potentialities of river-adjustment, and Prof. Davis, in his splendid contribution to evolutionary potamology, adopted and amplified Mr. Jukes Browne's views. Still later Mr. Burton further extended the study of the Trent, and furnished data inaccessible except to a Trent-side resident. The earlier chapters of his book

system, though not so decisively but that in seasons of flood it swept again across from the old elbow of capture at Newark and discharged its waters into the Wash. The Romans controlled this propensity by the creation of extensive floodbanks, but the degenerate moderns neglected to keep them in repair, so that in 1795, and twice in more recent times, the river has temporarily re-occupied its old course.

The later history and activities of the Trent are well described, and a special word of commendation must be bestowed upon the splendid half-tone illustrations, and in particular the two pictures of the bore or Ægir ("Sea-tempest is the Jötun Ægir, a very dangerous Jötun; and now to this day, on our river Trent as I learn, the Nottingham bargemen, when the river is in a certain flooded state . . . call it *Eager*; they cry out 'Have a care, there is Eager coming.'"—Carlyle). These are, we think, the finest pictures of this phenomenon that we remember to have seen. The excellence of the half-tone-illustra-

¹ "The Shaping of Lindsey by the Trent." By F. M. Burton. Pp. xii+59. (London: A. Brown and Sons, Ltd., 1907.) Price 2s. net.

tions stands in strong contrast to the very inadequate and unsatisfactory diagrams; that representing a section from the Trent valley to the coastal plain is about as misleading to the general reader as such a thing could be made; the vertical scale is nearly one hundred times the horizontal, and the dips are proportionately exaggerated, from the actual 2° or 3° to something like 65° or 70°. It is an aggravation of the offence to waste fine plate-paper on such a monstrosity.

Despite this and some minor blemishes the book is an interesting one, and should do something to stimulate an interest in the scientific study of the scenery of a region that is replete with beauty and charm.

THE SUN AND THE CLOCK.

LAST week a Bill was introduced into Parliament by Mr. R. Pearce, M.P., having for its object the better accommodation of the hours of business to the hours of daylight, to be accomplished by a device which, though simple in appearance, would in practice prove very troublesome. Custom and habit have so arranged the hours of the working day that the general tendency is to use more hours in the afternoon than in the morning. This unequal division is attended with many inconveniences, one of which is that we use artificial light for more hours than would be necessary if we would consent to divide our time more symmetrically with reference to the sun's meridian passage. It is not impossible but that greater economy and more healthy conditions for labour might follow, and so far as this is the purpose of the Bill, which owes its initiative to Mr. Willett, we can all sympathise. It would be an evident advantage to employ sunlight, which costs nothing, in the place of gas and electricity, which are expensive luxuries, and it is probable that it is this obvious benefit which has enlisted the good will of many well-known authorities to what on close examination seems to be rather a childish measure.

Mr. Pearce, who holds a brief for Mr. Willett, is anxious to begin the day earlier; he does not propose to curtail the hours of labour in any way, but simply to shift the hands of the clock so that for part of the year noon on the clock dial would not coincide with the transit of the mean sun. Since it is the clock and not the sun that regulates all affairs of business or pleasure, suitable arrangements could be made, but whether those proposed by the Bill are the most satisfactory is an open question. The Bill provides that on each of the first four Sundays in April standard time shall be advanced twenty minutes, making the clock gain on the sun eighty minutes in the course of the month. Ordinary office hours would therefore begin at 8.40 a.m. instead of ten o'clock, and, of course, end at 3.40 p.m. instead of five o'clock; as reckoned by the mean sun. In this way there would be approximately symmetrical distribution of the day on both sides of the meridian. In winter, when we use all the daylight available, nothing is gained by advancing the clock on solar time, and it is proposed to bring the clock and sun again into coincidence by putting standard time back twenty minutes on each of the first four Sundays in September.

This pushing the hands to and fro on the dial is, we are told, the whole cost of the scheme. Unfortunately, that statement is misleading. The hour chosen for this abrupt dislocation of continuity is two o'clock in the morning, an hour when very few people would care to make the necessary adjustment, and many a man on arriving at the station on Monday morning would find that his train had been gone

twenty minutes, or that he had to wait twenty minutes before it was due, according as the time of the year was spring or autumn. This continual interruption of uniformity would be intolerable. One can more easily accommodate himself to a burden, however grievous, if the pressure be constant, than to the petty irritation arising from frequent change.

But we would seriously ask the supporters of Mr. Willett's scheme where is the necessity for this aggravating policy of perpetual alteration? We suspect, if we could get at the truth, that this constant interference is a concession to inherited instinct, and a desire not to depose the sun too hurriedly from that position of preeminence which he has hitherto enjoyed. The author of the scheme manifests a cautious hesitancy lest some mischief should arise from separating the clock and the sun by too great an interval, and thinks to appease the possible objections of more conservative minds by pointing out that it is only for half a year that the clock is wrong. It looks as though he were afraid of his own measure, for what possible advantage can accrue from putting the clock back in September? If the measure be wise and acceptable, why not boldly alter the time one hour by one and a final interruption? In summer we should get nearly the same advantage as that claimed for this policy of pin-pricks, and in winter we should be no worse off.

It is quite a different question to ask, is such a measure desirable? or, further, whether the proposed remedy is the most judicious? It might be more satisfactory to effect some change in our habits and customs more in line with those that obtain on the Continent or in India. The hours of business or of social functions may in those countries be dictated by a desire to avoid heat and glare, but the point is that we should do well to follow the example of those who have considered the sun as a factor in regulating their affairs. Such ends cannot, however, be accomplished by legislative action, but by the decision of Society with a big S. To ask a man to dine at six instead of at eight would be a drastic revolution that few would feel themselves competent to inaugurate.

The Astronomer Royal has raised a point of great importance, at the same time hinting that the authors of the scheme have thought too much of the convenience of their own order and too little of that of the great majority of the public, whose daily life begins far earlier than Mr. Willett seems to imagine. Where life is strenuous, in factory or workshop, in dock or on railway, toilers quit their homes soon after five o'clock by the sun. It is easy to conceive that earlier rising would entail a hardship. Those who minister to the comfort of Mr. Willett and his class accomplish much before the more leisureed day begins. The handling of perishable articles and the distribution of food in great centres of population goes on all night. To shorten that night by an hour or more to get the same amount of work done in a shorter time would tax resources to breaking point.

There is, too, another consideration which is not without its weight. England has succeeded in securing the recognition of the Greenwich meridian as the origin of time throughout the world, and with something like uniformity time is reckoned from that meridian. Is it desirable to commence an agitation which involves a breach, though only nominal, of that uniformity? We have admitted that there are some advantages to be derived from the adoption of the scheme, but when weighed against the disadvantages arising from a fretful disorganisation, it may be "better to suffer the ills we have than fly to others we know not of."

IRISH FISHERY INVESTIGATIONS.¹

THESE two volumes form the third and fourth reports upon the scientific investigations into fishery questions, which have been conducted for the Irish department responsible for the fisheries by Mr. E. W. L. Holt, the scientific adviser. They fully maintain the high standard set by their two predecessors both in the nature of their contents and in the manner in which they are printed and illustrated.

It is a matter for congratulation that the Irish Government has adopted so comprehensive and intelligent a view of the manner in which such investigations should be planned and carried out, and it is to be hoped that any narrow and uninstructed criticism, such as Mr. Holt appears to suggest has been made upon the work, may not be allowed to interfere in any way with its progress. "In my last report," says Mr. Holt in the volume for 1904, "I endeavoured to make it clear that the papers in the appendix, even if couched in unavoidably technical language, did actually contain information essential to the possibility of success in attack on practical fishery questions. The endeavour seems to have failed to some extent, but perhaps in the course of time it may be more generally surmised that if a due understanding of the minutiae of habit and environment is of some use in agriculture, so may it also be in the direction of piscatorial enterprise, and that because an animal has an unfamiliar name it does not necessarily follow that it is of no importance."

The kind of criticism of which Mr. Holt here appears to complain would seem to be similar to that to which the work carried out by Prof. Herdman in the Irish Sea has recently been subjected. At a meeting last year of the Lancashire and Western Sea Fisheries Committee, a member of the committee, the Rev. J. E. Green, is reported by the *Liverpool Daily Post and Mercury* to have said "he thought they ought to manage to cut down the expense of the annual report. The printing came to about 70*l.* a year, and there was a quantity of verbiage in it which was not easily understood. For instance, they had a long list of Latin names which he had taken the trouble to try and translate, with the assistance of the latest work of Lewis and Short, but he had failed to do so. If the names were to be inserted, the translations should also be put by the side, for they were absolutely useless unless the Lancashire fishermen happened to be graduates of the Liverpool University."

The picture of the diligent committeeman seeking a translation of the specific names used by naturalists "in the latest work of Lewis and Short" has its humorous side. We fear his method might even be somewhat misleading in the case of such a simple specific name as *Homo sapiens*. Both Mr. Holt and Prof. Herdman must, however, take comfort from the fact that the difficulty of making the general public, or those who happen to occupy positions of authority, realise the importance of technical biological studies is one which most scientific investigators have to face, and for some unexplained reason is met with in a particularly aggravated form in the case of fishery work.

Mr. Holt's report for 1904 is followed by six, and that for 1905 by seven, appendices dealing with marine work, whilst in each case one appendix is devoted to inland fisheries. Of the former, one only deals directly with fishes, that by Holt and Byrne on the fishes of the Irish Atlantic Slope. This paper contains sixteen

¹ "Report on the Sea and Inland Fisheries of Ireland for 1904." Part II. Scientific Investigations. Department of Agriculture and Technical Instruction for Ireland. Dated for 1905. (Dublin: Published for H.M. Stationery Office by A. Thom and Co., Ltd., 1906 and 1907.) Price 4*s.* 4*d.* and 2*s.* 1*d.*

additions to the list of the fish fauna of the British-and-Irish area, which have resulted from the operations of the fishery steamer *Helga*.

The Crustacea, a group which is of such great importance from the point of view of the food of fishes, receive considerable attention. Dr. W. T. Calman records forty-eight species of Cumacea from the west coast of Ireland, of which nine are new to science. The latter are carefully described, and the details of their external characters are illustrated in eighty-six well-executed figures.

Mr. Tattersall treats in a similar way the Isopoda and pelagic Amphipoda from the same region, ten new species of Isopoda and four new species of Amphipoda being described and figured. Mr. Tattersall and Mr. Holt add a supplement to their former report on the Schizopoda, and Mr. Stanley Kemp contributes a useful review of the Decapod genus *Acanthephyra*. Miss Delap's notes on the rearing in an aquarium of *Aurelia aurita* and *Pelagia perla* are also of great interest.

The most important sections in the appendices on inland fisheries are Mr. Holt's reports on the artificial propagation of the Salmonidae and Mr. Hillas's record of salmon-marking experiments.

The two volumes make it clear that a very large amount of most useful work is being carried out, the value of which will increase at a very rapid rate as the data accumulate from year to year.

NOTES.

IN the House of Commons on Monday, Mr. Mallet asked the Secretary of State for War whether he was aware of the public service rendered by a commission of the Royal Society, at the request of the War Office and the Admiralty, in discovering the cause of Malta fever, from which many hundreds annually of our soldiers and sailors on that island until recently suffered; and whether, in view of the importance of this discovery in the annals of preventive medicine, inasmuch as at the present moment the disease had been entirely stamped out, he would consider the desirability of giving the thanks of the Government to the Royal Society for this instance of the successful application of British scientific research? In his reply to this question Mr. Haldane said:—"I am aware of the great service rendered by the commission in question. The commission's investigations and the adoption of preventive measures as the outcome of its recommendations have been followed by the practical disappearance of Malta fever from the garrison of the island. I think that the Royal Society is well aware how genuine is the appreciation of the Government. We owe much to the Royal Society's commission for the successful issue of this remarkable investigation, and for the excellent results which have followed. These results illustrate the enormous importance of bringing science into our business of government."

WE announce with great regret that Lieutenant-General Sir Richard Strachey, G.C.S.I., F.R.S., died on February 12 at ninety-one years of age.

THE following have been elected honorary and foreign members of the Chemical Society:—A. E. J. Gautier, Paris; A. Haller, Paris; J. W. Hittorf, Münster; J. A. Le Bel, Paris; H. L. Le Chatelier, Paris; T. W. Richards, Cambridge, Mass., U.S.A.; and O. Wallach, Göttingen.

THE Paris Academy of Sciences has, says the *Revue Scientifique*, in cooperation with the Minister of Public Instruction, undertaken, at the invitation of Sir Norman

Lockyer, K.C.B., F.R.S., to form a committee of French men of science to assist in securing an important place for science in the forthcoming Franco-British Exhibition.

It is stated in the *Pioneer Mail* that special subcommittees have been appointed by the Board of Scientific Advice for India to consider and report on proposals which have been submitted for the re-organisation of the Botanical Survey Department and the future organisation of the Economic Products Department.

WE learn from *Science* that Prof. W. Stratford, for forty-one years a member of the teaching staff of the New York City College, died on January 24. Prof. Stratford was a well-known member of the scientific organisations of New York, and was a recognised expert in biological microscopy. In his work in the City College he introduced laboratory methods and developed its museum, enriching it with the fruits of several palæontological excursions to the Rockies.

A ROYAL Commission has been appointed to consider, among other matters, the materials or the processes used in the manufacture or preparation of whisky and other kinds of potable spirits manufactured in or imported into the United Kingdom. The chairman of the commission is Lord James of Hereford, and the members are:—Mr. L. M. Guillemaud, C.B., Dr. W. E. Adeney, Dr. J. R. Bradford, F.R.S., Dr. H. T. Brown, F.R.S., Dr. G. S. Buchanan, Mr. J. Y. Buchanan, F.R.S., and Dr. A. R. Cushny, F.R.S. The secretary to the commission is Mr. A. V. Symonds, of the Local Government Board. The appointment of this commission arises out of the difficulties described in an article on "What is Whisky?" which appeared in *NATURE* of March 8, 1906 (vol. lxxiii, p. 441).

At a meeting of copper and brass manufacturers, engineers and others, held in Manchester on February 13 (Mr. W. H. Johnson in the chair), it was unanimously resolved to form a Copper and Brass Institute having similar objects to those of the Iron and Steel Institute. It is not the intention of the founders to limit the institute to the copper and brass trades, but to include all those connected with the commercially important non-ferrous metals and their alloys, as lead, zinc, tin, aluminium, nickel, silver, gold, platinum, &c., and their alloys. A further meeting will be held in the Midland Hotel, Manchester, on Tuesday, March 10, at 4 p.m., to which all those interested are most cordially invited. Prof. H. C. H. Carpenter, professor of metallurgy, The University, Manchester, will receive the names of any persons who propose to attend or are interested in the formation of the institute.

THE meteorological observatory on Ben Nevis was again the subject of a question in the House of Commons on Monday, when the Chancellor of the Exchequer was asked whether he could hold out any prospect of a grant towards its upkeep. In the course of his reply, Mr. Asquith said that the only scheme which has up to the present been placed before him is one under which the whole cost of the re-equipment and maintenance of the observatories would be thrown upon public funds, and to this he does not feel justified in assenting. He is, however, quite prepared to consider the question of renewing the Government grant, which was for many years given to the Ben Nevis observatories through the Meteorological Council, provided that an adequate contribution towards their re-
establishment and maintenance is forthcoming from other

be called "The Transvaal Biological Society," with the object of promoting the discussion of scientific problems by biological investigation, to arrange for regular meetings for this purpose, and to publish the proceedings of the meetings. All persons are eligible for membership who are actually engaged in biological investigations and have published at least one scientific paper, or are working on such. Every member is expected to furnish at least one paper each year. The committee for the current year consists of Dr. Theiler, C.M.G., president; Mr. Burt-Davy, vice-president; and Dr. L. H. Gough, secretary and treasurer. The new society will fill a long-felt want in Pretoria.

PROF. G. K. GILBERT, in his recent report to the United States Geological Survey, stated that the conditions of flow and erosion at Niagara Falls would soon cease to be natural, owing to the large amount of water diverted for industrial purposes. The correspondent of the *Times* at Washington, as we note in that journal for February 14, gives an abstract of the views of Dr. Spencer, of the Canadian Survey, which are far more specific and alarming. Dr. Spencer, it appears, looks forward to the practical disappearance of the American falls, through the utilisation of water-rights already conceded; and the correspondent suggests that Congress would be favourable to the incorporation of an agreement for the regulation of the waters of the Niagara River in the general treaty respecting questions pending between the United States and Great Britain.

It was suggested by Mr. R. Pohl in a paper read before the German Physical Society in June last that the formation of gas bubbles in the glass of vacuum tubes, described by Mr. A. A. Campbell Swinton in a paper before the Royal Society (see *NATURE*, April 4, 1907, p. 550), is due to a metallic film caused by disintegration of the internal aluminium electrodes, and that if the aluminium be first completely etched away, then no bubbles are formed in the glass when it is subsequently heated. Mr. Swinton writes, however, to say that these conclusions are disproved by some further experiments recently carried out by him, in which a plentiful supply of bubbles was easily obtained in the glass of tubes which had been excited over prolonged periods by electrostatic induction from outside, and in which there were no aluminium or other internal electrodes to disintegrate and cause the metallic film to which Mr. Pohl attributes the effect.

SEVERAL interesting speeches were made at a dinner of the Physical Society held on February 11 at the Hotel Cecil, when the chair was taken by the president, Prof. J. Perry, F.R.S., and a number of distinguished guests and fellows of the society were present. In the course of some remarks, Sir William Ramsay dwelt on the relations of physics and chemistry. He pointed out that one of the chief difficulties of the chemist at the present time is the solution of the mathematical problems involved in chemistry, and there is a great opening for "tame mathematicians" who will hold themselves at the disposal of the chemist. In response to the president, Prof. E. B. Rosa, of the National Bureau of Standards, Washington, stated that he had been greatly interested in visiting the National Physical Laboratory, and observing the progress that had been made since his last visit five years ago. At the National Bureau of Standards satisfactory headway is being made, and it is hoped that the laboratory will shortly be equal to any national laboratory in the world. In the United States much money is being spent on the science of agriculture, because agriculture is a national asset. Prof. Rosa suggested that England similarly would

A meeting held in the Transvaal Museum, Pretoria, on January 13, it was resolved to form an association, to

find it a profitable investment to devote the money spent in constructing one battleship per annum to the National Physical Laboratory instead of preparing for war. In responding to the toast of "The Physical Society," the president dwelt on the importance of research. At the present day there are many science teachers and many compilers of books who do no research. They are well up in the letter of science, but not in the spirit thereof, with the result that their writings lack a most essential quality which can be gained only by actual research. He appealed to the leaders of physical science to attend the meetings of the society, not for their own benefit, but from a sense of duty, for there is nothing so inspiring to the younger members as contact with men who have carried out important work.

From Mr. F. L. Dames, of Berlin, we have received a catalogue of books and papers on entomological subjects (No. 96, *Bibliotheca Entomologica*).

No. 7 of Irish Fisheries Scientific Investigations for 1906 (1907) contains a report on artificial salmon and trout breeding for the season 1906-7, from which it appears that the total for salmon comes within about 500,000 of that of the previous season, and therefore is by about that number in excess of any previous year.

Two papers on regeneration are included in vol. lxxxix., part i., of the *Zeitschrift für wissenschaftliche Zoologie*. In the first of these Mr. J. Nusbbaum describes the processes occurring in one of the polychaete worms of the genus *Nereis*, while in the second Mr. J. Grochmalicki discusses the regeneration of the lens of the eye in bony fishes. In the case of one particular fish from which this organ had been extirpated, a new lens, differing slightly in form from the original, was developed in 187 days.

In the course of an article on hermaphroditism in echinoderms, published in Nos. 6 and 7 of the *Travaux de la Société Impériale des Naturalistes de St. Pétersbourg* for 1907, the author, Mr. G. Gadd, argues that since this phenomenon is not uncommon in sea-cucumbers, more rare in star-fishes, and almost unknown in sea-urchins, we have a confirmation of the view that it is an attribute of the less highly organised members of the groups in which it occurs.

To the *Museum Journal* for January Dr. H. C. Sorby contributes a paper on the best means of preserving marine invertebrates for museum purposes in such a manner that their natural colouring will be retained. As regards his own private collection, the author finds anhydrous glycerin—covered, when necessary, with a layer of almond oil—the most satisfactory medium, some specimens which have been preserved in this manner for fully five years displaying their tints with even more than normal brilliancy. The chief difficulty in the case of museum specimens would be in the use of large rectangular vessels, owing to danger of leakage.

The *Lyttelton Times* (New Zealand) of December 3, 1907, contains a long summary of the results of the recent scientific expedition to Auckland, Campbell, and other islands lying to the southward of New Zealand. Mr. Speight, geologist to the expedition, claims to have discovered in Auckland, Campbell, Snares, and Disappointment (not apparently the island of the same name in the Low Archipelago, but one somewhere near the others) rocks indicating that these islands once formed a part of the Antarctic continent. The islands have also been ex-

tensively glaciated. Of insects, flies and tipulæ are the most numerous, but beetles and dragon-flies were also observed. A linnet-like bird from Campbell Island has not yet been identified; and successful photographs have been obtained of the skua, shag, mollymawk, gull, albatross, and penguin rookeries. On Snares Island the stench from the birds and seals is stated to have been almost intolerable, and the members of the expedition who visited the Campbell group suffered severely from the colds and wind.

A SPECIAL paragraph in the issue quoted above is devoted to Disappointment Island, which was visited by Dr. L. Cockayne, who devoted special attention to the vegetation. Although the number of species is small, the vegetation as a whole is comparatively luxuriant. Very striking is the large *Aciphylla latifolia*, a member of the rorot tribe, while the male flowers of the orange lily, *Bulbinella rossi*, are conspicuous. "The most interesting feature of all is the natural rejuvenation of the vegetation that is going on. Cast your eye over the landscape, and you will see brown meadow dotted with white birds, which slowly but surely kill out all the plant-covering, and patches of vivid green. This latter arises from the presence of the Antarctic burr, or piri-piri, in enormous quantities; and it, a quite rare plant in a virgin meadow, has spread from thence and occupied the new ground, thanks to its colonising power, its spiky fruits adhering to the feathers of the young birds and so being spread broadcast. Here there is a splendid example of a plant of little importance becoming virtually a weed in a virgin vegetation. But finally tussock will resume the sway, and a gradual destruction and rejuvenation of the vegetation must go on, thanks to the mollymawks."

In the February number of *British Birds* the editors discuss certain allegations against the black-headed gull which formed the subject of notice in the previous issue. Without entering into the controversy, we may notice that the allegations have induced two county councils in Scotland to strike gulls of all kinds out of the protected list. In another paragraph the editors refer to the subject of "luminous owls." In their opinion, the luminosity is most probably to be attributed to phosphorescent bacteria derived from decaying wood. It may, however, be due either to a phosphorescent feather-fungus (akin to one known to occur in geese) or to a diseased condition of the oil-gland, whereby the oil is more abundant than usual, and so abnormal in its nature as to become luminous on exposure to the air. Whatever be the true explanation, it is evident that the phenomenon is abnormal, and almost certainly due to the presence of 'foreign' matter on the feathers.

THE reports on the botanic and experiment stations and agricultural education in St. Kitts-Nevis for 1906-7, besides reviewing the work for the year, summarise the progress made since the institution of the Imperial Department of Agriculture for the West Indies. The sugar industry has benefited by the introduction of the seedling canes B.147 and B.208; cotton cultivation has been developed since 1901, when trial plots were started; until an area of 5000 acres is now planted in the three islands St. Kitts, Nevis, and Anguilla. The cultivation of cacao proceeds more slowly, but gives promise of success. Rubber planting, chiefly with *Castilloa elastica*, is also receiving attention. The records of the experiment plots provide useful data with regard to growing tobacco, varieties of potatoes, cassava, yams, sweet potatoes, and other minor products.

ACTING upon the advice of Prof. H. J. Hamburger, it was decided to publish in the *Recueil de l'Institut botanique de Bruxelles* (vol. vii.) the course of lectures on molecular physiology delivered by the late Prof. Errera to students taking the botanical degree in the University. It is primarily a physicochemical course dealing with the properties of fluids and solids, and the special application of the laws regulating their action to various botanical problems. Surface tension of liquids, viscosity, properties of emulsions, circulation of gases and liquids in narrow tubes, and similar phenomena are treated with regard to their bearing in plants, and especially with reference to the two important subjects of osmosis and the ascent of sap in trees. Practical examples of calculations in connection with osmotic problems are given, and the discussion of the various theories put forward to explain the ascent of sap is illustrative of Prof. Errera's lucid exposition.

THE *West Indian Bulletin* (No. 3, vol. viii.) contains summaries of several of the papers presented to the famous agricultural conference of 1907. Mr. Gossett points out how valuable Indian cattle have proved in Jamaica; they are said to surpass all others as workers, and to be so remarkably hardy in constitution that they withstand the effects of the climate, of insects, and other pests, besides being able to subsist on coarse grasses and shrubs that other cattle would refuse. Another paper deals with the suitability of Jamaica for breeding horses, mules, and polo ponies. Mr. Cox discusses the prospects of tea production, and concludes that tea is a safe crop for a settler who lives within reach of a factory. Mr. Cousins contributes two papers, one on cassava starch and the other on agricultural education in Jamaica. He finds that cassava starch of high quality and commanding a good price can be produced in Jamaica at a cost which allows a very handsome profit. Other papers deal with Jamaica ginger and with the native timbers. The standard of the papers is very good, and all the authors are very hopeful about the future. They have good reason, for few of our possessions have better agricultural departments than the West Indies.

THE second number of the *Bulletin of the Imperial Central Agricultural Experiment Station of Japan* is to hand, and is in every way an excellent production. One paper deals with the behaviour of nitrate of soda in paddy soils. Nagaoka found some years ago that this fertiliser actually depressed the yields of rice, *Sagittaria*, and *Juncus effusus* when cultivated, as is usual in Japan, on swampy soils. He considered that the effect was due to denitrification, a process which would give rise, among other things, to poisonous nitrites. It is now shown that this view is correct. Another paper, by Uchiyama, deals with the influence of stimulating compounds such as manganese and iron salts, sodium fluoride and potassium iodide on crops, a subject to which considerable attention has been devoted in Japan. The general conclusion is that manganese sulphate at the rate of 20 kilos. to 50 kilos. per hectare increases the crop, but the actual amount of the increase depends on a variety of factors. The most favourable ratio of lime to magnesia in soils forms the subject of several papers. There is also an important synoptical list of Coccidae of Japan, with descriptions of thirteen new species by Kuwana. The bulletin is profusely illustrated, and the illustrations are unusually good.

THE report of the chief of the U.S. Weather Bureau for the year ended June 30, 1906, has just reached us. In the department dealing with weather prediction,

the distinctive work of the year was the study of atmospheric movements in the United States with the additional light afforded by reports from the Azores, western Europe, Honolulu, and other places, the result of which has been sufficiently encouraging to warrant a still further extension of area. The amazing figures connected with the receipt of telegraphic reports and the distribution of meteorological information were referred to in *NATURE*, vol. lxxvi., p. 300. There has been considerable increase of observing stations of various classes; the number now amounts to more than 4500. The report contains, *inter alia*, observations or summaries for a large number of selected places, and monthly and annual rainfall values for all stations, for the year 1905, the whole occupying 405 quarto pages. At Mount Weather Research Observatory systematic work is carried on in connection with the international kite experiments; the institution possesses a very complete instrumental outfit for the purpose. Among various other useful operations of the bureau, we may mention that efforts are being made to correlate and reduce to a uniform system the teaching of meteorology in the numerous colleges and schools; circular letters on the subject have apparently been addressed to a large number of educational establishments.

AN important paper on the smoke from metallurgical works, by Mr. W. D. Harkins and Mr. R. E. Swain, is contained in the *Journal of the American Chemical Society* (vol. xxix., No. 4). The work which led to the publication of the paper was the estimation of the amount of arsenic expelled from the greatest of the world's smelting works, a plant which has a capacity of 10,000 tons of ore per day, and a production estimated at 11½ per cent. of the world's output of copper. It has been found that not only are the trees and grass in the vicinity of works injured by the sulphur dioxide and sulphuric acid of the smoke, but the grass is also rendered poisonous by arsenic. By the erection of new works with huge settling chambers in place of the long flues of the old works, the loss of animals in the valley became very much greater than before. The velocity determinations and analyses of smoke set forth in the paper were undertaken with a view to determine the real efficiency of the great flues and stack, 300 feet high, built in order to prevent damage to the forests and crops. The velocity determinations were made with a Pitot tube, modified by Captain D. W. Taylor, which was found to give much more trustworthy results than the wheel anemometer. The results of the investigation show that while the great flue may be fairly efficient in causing the copper from the smoke to settle, a considerable amount escapes, while the amount of arsenic given off is very great. The arsenic is chiefly in the form of trioxide, but a small amount exists in the form of trisulphide and in the form of complex minerals containing iron. The dust from the flue near the stack or in the stack itself contains a considerable amount of concentrated sulphuric acid, while that from near the furnaces contains much less. To this sulphuric acid, together with the arsenic with which it is associated, is probably due much of the spotting of leaves which is so common in the vicinity of the works. The action of the flue dust is of far less importance than that of the sulphur dioxide in affecting the growth of plants, but the arsenic of the dust may affect to a greater degree the value of the grasses, since it renders them poisonous.

MESSRS. C. WOOLLCROFT AND SON, LTD., Hanley, Staffs, ask for information as to an electrostatic separator for the purpose of extracting iron pyrites. An expert to whom we referred the inquiry has been good enough to

reply that the latest type of electrostatic separator is the Blake-Morscher, which was described in a paper read before the Institution of Mining and Metallurgy by E. A. Weinberg (Transactions, 1905, vol. xiv., p. 169). It is of American manufacture, and can probably be obtained from Fraser and Chalmers, of Erith. Earlier forms are exhaustively described in a paper read by H. C. McNeill before the Iron and Steel Institute (Journal, 1899, vol. lvi., p. 18). Machinery for the extraction of iron pyrites is made by the German "Humboldt Company," of Kalk, near Cologne.

THE *Verhandlungen der deutschen physikalischen Gesellschaft* for December, 1907, contains a communication from Prof. E. Wiedemann, in which he directs attention to two Arabic books of the thirteenth and fourteenth centuries, in the former of which the method of magnetising a steel needle by rubbing it on a natural lodestone is described, while in the latter instructions are given for mounting a needle so magnetised within a wooden fish, which when placed on water heads always to the north. This appears to be the first known mention of the compass, although the matter is treated as if it were common knowledge at the time.

VOL. iv. of "Contributions from the Jefferson Physical Laboratory of Harvard University" contains thirteen memoirs, five of which are from the pen of Prof. B. O. Peirce. Most of these memoirs are reprinted from vol. xlii. of the Proceedings of the American Academy of Arts and Sciences, 1906. There is one, on architectural acoustics, by Prof. W. C. Sabine, reprinted from the *American Architect* for 1900, which well deserves close attention from architects in this country. It is a thoroughly scientific attack on the problem of determining the acoustical properties of a room before it is built. The author describes his measurements of the absorbing powers of walls, screens, furniture, and audience, and shows how the constants thus determined can be used in calculating the amount of reverberation to be expected in a large number of cases. In each case direct measurement confirmed the result of the calculation.

THE report for 1908 of the International Committee on Atomic Weights is printed in No. 335 of the Proceedings of the Chemical Society. From the data here given, and from those cited in previous reports, it is concluded that the entire table of atomic weights is in need of revision. The values assigned to potassium and sodium are too high; those given to chlorine and sulphur are too low, and these constants affect the determination of many others. They depend, however, on the atomic weight of silver, which is probably, but not certainly, as low as 107.88. It is well known that work upon these fundamental constants is now nearing completion in several laboratories, and within a few months it should be possible to enter upon a satisfactory revision of the table, a task which would be unsatisfactory if undertaken now. It is true that the present table contains inconsistencies, but they are small in amount, and are due to inconsistencies in the original data from which the values are derived. Since issuing the last report Prof. Moissan has died, and has been succeeded on the committee by M. G. Urbain. The report being drawn up in November last does not deal with the striking result obtained by W. Marekwald in the case of tellurium, which has been published since; this element has long held an abnormal position in the periodic arrangement owing to its appearing to have an atomic weight greater than that of iodine. According to Marek-

wald, its correct atomic weight is 126.85, that is, 0.12 unit less than the atomic weight of iodine, so that it now falls into line with the rest of the elements.

A SECOND edition of Mr. Arthur Whiting's "Retouching" has been published by Messrs. Dawbarn and Ward, Ltd.

A SECOND edition of the useful "Handbook to the Vivaria and Fresh-water Aquaria" at the Horniman Museum, Forest Hill, S.E., has been issued by the London County Council. Copies may be obtained through a bookseller, or directly from Messrs. P. S. King and Son, of Westminster; the price of the catalogue is one penny.

MESSRS. CROSBY LOCKWOOD AND SOX have published a fifth edition of Dr. Bernard Dyer's "Fertilisers and Feeding Stuffs: their Properties and Uses," which contains also the full text of the Fertilisers and Feeding Stuffs Act, 1906, the regulations and forms of the Board of Agriculture, and notes on the Act by Mr. A. J. David. The new edition has been revised, and its price is 1s. net.

OUR ASTRONOMICAL COLUMN.

THE RECENT SPECTRUM AND MAGNITUDE OF NOVA PERSEI No. 2.—The results of Prof. Hartmann's more recent investigations of the spectrum of Nova Persei No. 2 (1901) appear in No. 4232 of the *Astronomische Nachrichten* (p. 113, February 8). Finding that when the magnitude of the star became less than 10.0 he was unable to photograph the spectrum with the large instrument used in the previous investigation, Prof. Hartmann devised a new spectroscope in which the collimator objective, of 40 mm. aperture and 60 cm. focal length, was made of U.V. glass, and the camera objective was made of quartz, having an aperture of 40 mm. and a focal length of 32 cm.; quartz prisms were employed, and the distance between H β and H δ on the plate was 4.6 mm. This spectrograph was used in conjunction with the 80-cm. refractor, and a good spectrum was obtained with $\frac{3}{4}$ hours' exposure on October 15 and 18, 1907, when the Nova's magnitude was 11.4. The main feature of this spectrum is its similarity to the spectrum of the Wolf-Rayet star B.D. 3574001. In both spectra the brightest line is at λ 4688, whilst H β , H γ , and H δ are more faintly shown. The fairly strong line in the spectrum of the W.-R. star at λ 4618 is comparatively faint in that of the Nova, whilst the trace of a line in the latter at λ 3800 is not to be found in the Wolf-Rayet spectrum. The chief nebula lines at $\lambda\lambda$ 5007 and 4959 are apparently absent from both spectra or are very faint.

Determinations of the magnitude of the Nova gave the following results:—1905, November 1, 11.2; 1906, November 24, 11.3; and 1907, October 13, 11.44.

THE HELIUM LINE, D $_3$, AS A DARK LINE IN THE SOLAR SPECTRUM.—In No. 393 of the *Observatory* (p. 94, February) Mr. A. A. Buss discusses the article by Father Cortie, which appeared in the January number, anent the presence of the dark, D $_3$, line of helium in the solar spectrum. From our previous note (No. 1905, p. 281, January 23) it will be remembered that Father Cortie discussed a photograph obtained by Mr. Nagaraja, on which both the dark and the bright line of helium, D $_3$, were supposed to be represented, and came to the conclusion that the identification was, possibly, a mistaken one. Mr. Buss now advances a number of arguments upholding the original view. In the first place, he points out that any arguments on this question suffer considerable uncertainty owing to different values being given for the principal lines under discussion. Thus Runge and Paschen give 5875.870 as the wave-length of the laboratory emission line, whilst in Young's revised list the wave-length of the chromospheric line is given as 5876; that the latter, compared with the laboratory line, suffers displacement towards the red is indicated by several different observations. Mr. Nagaraja's dark line lies almost exactly midway between the two, at λ 5875.930, therefore Mr. Buss considers that

It is, probably, the helium line. Other evidence and his own observations of the dark D₁ line in active areas outside the umbral regions of spots support this view.

A DETAILED STUDY OF THE PHOTOSPHERE.—In No. 1895 of NATURE (vol. lxxiii., p. 401, February 22, 1906) we published an article dealing with Prof. Hansky's study of the size and movements of the granules comprising the solar photospheric surface. Mr. Chevalier, of the Zô-sé Observatory, China, has for some time been engaged on a similar study, and publishes some very interesting results, with photographs, in No. 1, vol. xxvii., of the *Astro-physical Journal* (January, p. 12). The principal conclusions deduced from the results show that on comparing photographs taken at one minute or half-minute intervals the same photospheric granules may be easily recognised, although their shapes and brilliancies undergo considerable changes. A more detailed comparison shows changes in their relative positions, the magnitude of the changes differing greatly both in direction and velocity. The velocities obtained range from 0 to 30 or more kilometres per second, and, in the mean, are much lower than those obtained by Prof. Hansky.

SECTIONAL ADDRESSES AT THE CHICAGO MEETING OF THE AMERICAN ASSOCIATION.

BY the courtesy of Dr. L. O. Howard, permanent secretary of the American Association for the Advancement of Science, we have been favoured with copies of several addresses delivered by chairmen of sections of the association at the recent Chicago meeting, of which an account was given in NATURE of January 30. Subjoined are summaries of some of the points of interest in these addresses. A summary of the president's address appeared in NATURE of January 23.

Music and Melody.

In his address to Section B (physics) Prof. W. C. Sabine chose as his topic "Melody and the Origin of the Musical Scale," the discourse being a critique of views published fifty-five years ago by Helmholtz in his "Tonempfindungen." It is pointed out that in part ii. of that work Helmholtz gave a physical and physiological explanation of the harmony and discord of simultaneous sounds, and Prof. Sabine briefly quotes Helmholtz's description of the structure of the human ear, so far as it is required to explain why overlapping tones produce a sense of discord, thus leading to the necessity of a musical scale with regular intervals for the building up of harmonies. But in applying this principle to account for the origin of such a scale, Helmholtz was met by an apparent anachronism.

Up to the eleventh or twelfth century only homophonic music existed, this consisting merely in the progression of single-part melody. The existing music of the Oriental and Asiatic races belongs to this type, and Helmholtz, admitting that between sounds which reach the ear in discrete succession there could be neither harmony nor discord, nor beats, sought another explanation for the fact that musical scales were existent long before the introduction of polyphonic and harmonic music. Prof. Sabine now offers a new explanation of this particular point. When sounds are produced inside a closed space such as a building, they continue to reverberate for a certain interval after the exciting source has ceased to exist. In this connection Prof. Sabine gives (without, however, specifying the units) a list of the absorbing powers of different substances. It follows that as soon as melodies were performed inside buildings such as temples of worship, the consecutive notes became blended, and this overlapping produced all the conditions necessary for the production of the harmonies and discords discussed by Helmholtz in explanation of the chordal use of the musical scale. This proposed theory of Prof. Sabine's would (so it is claimed) account for the absence of a musical scale among the native tribes of Africa.

The Problem of Heredity.

It is a sign of the times that the addresses delivered before the American Association by Dr. D. T. Macdougall,

a botanist, and by Dr. E. G. Conklin, a zoologist, are not about botany and zoology respectively, but that both deal with heredity; and it is evidence of the vastness of the topic with which they deal that, though they both treat of the mechanism of heredity, their two addresses do not overlap. Both addresses are admirable examples of what such addresses should be. Their opening sentences exhibit a breadth of view which, if we may say so, has not been a distinguishing feature of a great deal of recent American biological literature; and both addresses contain such a wealth of references to, and accounts of, new observations and experiments which bear on the interpretation of fundamental problems that the earnest biologist will do well to read them both.

Dr. Macdougall opens his address on "Heredity and Environic Forces" with some well-needed remarks on the assumption that the changes which ensue when a plant is transported to a violently different environment—as, for example, when a mesophyte is grown as a xerophyte—are adaptive changes. According to Dr. Macdougall, these are not only assumptions, but unwarrantable ones. Certain of the changes which accompany the transportation do undoubtedly benefit the plant in its new surroundings, "but results of the opposite character are encountered. Thus in my experiments with *Roripa*, the American watercress, it was seen to bear filiform, dissected leaves when submerged, linear dissected leaves when emerged, but when acclimatised at the Desert Laboratory developed broadly ovate, almost entire laminae." Similarly etiolation, usually regarded as an adaptive change which enables the plant to lift its head above objects which keep the light from it, was found to occur in less than half the species tested, the majority "showing thickened organs and other useless alterations." Lastly, he cites the proof given by Lloyd that the movements of stomata are not adaptive or regulatory with respect to transpiration. We can heartily endorse Dr. Macdougall's conclusion on this part of his subject (as he happily phrases it in his native tongue), "that the entire matter of causal adaptations is in need of a basal re-investigation from an entirely new viewpoint."

But the most interesting part of this address is that which deals with the author's successful attempts to modify permanently the germ-plasms of plants by subjecting them to the influence of various chemicals. "It was found that the injection of various solutions into ovaries of *Raimannia* was followed by the production of seeds bearing qualities not exhibited by the parent, wholly irreversible, and fully transmissible in successive generations. One of the seeds produced by a plant of *Oenothera biennis* which had been treated with zinc sulphate differed so widely from the parental form that it could be distinguished from it by a novice. This new form "has been tested to the third generation, transmits all its characteristics fully, and does not readily hybridise with the parent even when grown so closely in contact with it that the branches interlock." Results as remarkable as this need confirmation, and it is to be hoped that similar experiments will shortly be undertaken in this country.

In his address on "The Mechanism of Heredity," Dr. E. G. Conklin suggests an answer to the question which always puzzles the philosophical biologist, "What exactly is the problem of heredity? How does it differ from that of development?" Dr. Conklin's answer is what at first sight would seem to be the natural and logical consequence of the acceptance of Weismann's doctrine of the continuity of the germ-plasm; it is, in fact, that there is little difference between the two problems. "Indeed, Heredity is not a peculiar or unique principle; for it is only similarity of growth and differentiation in successive generations. . . . In fact, the whole process of development is one of growth and differentiation, and similarity of these in parents and offspring constitutes hereditary likeness. The causes of heredity are thus reduced to the causes of the successive differentiations of development, and the mechanism of heredity is merely the mechanism of differentiation." Having reduced the problem of heredity to this, Dr. Conklin goes on to consider the evidence for the view that the chromosomes are solely concerned in the process of differentiation, and expresses himself as definitely opposed to that view. He is not

content with holding that the phenomena of differentiation may be the result of the interaction of nucleus and cytoplasm, but he goes on to assert that, as the animal pole of the egg becomes the animal or sense pole in all animals, and the cytoplasm in this region gives rise to the ectoderm of the developing animal, and as this polarity can be traced far back into the ovarian history of the egg, and in some cases is probably continuous from generation to generation, that "we have here an important character which is inherited through the cytoplasm and not through the nucleus." Dr. Conklin's final conclusion is that at the time of fertilisation the hereditary potencies of the two germ cells are not equal, because all the "early development, including the polarity, symmetry, type of cleavage, and the relative positions and proportions of future organs," are determined solely by the cytoplasm of the egg-cell.

Anthropology of California.

In his address as president of Section II (anthropology) of the American Association, Prof. A. L. Kroeber reviewed the progress of anthropology in California. Commencing with language, he pointed out that Powell's arrangement of about twenty linguistic stocks had not been disturbed by later investigations. The loose statements formerly made that the number of unrelated dialects of each stock was often very great, and that these dialects showed a gradual continuous change from one end of the territory occupied by a stock to another, have been found to be entirely erroneous. There are some loan-words common to contiguous stocks, but these are few, and the peculiarity of the linguistic problem lies in the fact that each form of speech occupies a well-defined area. So far, three great groups—north-western, south-western, and central—have been clearly traced, and the similarities between them, which up to the present have been ascertained, are not of such a nature as to be of bearing on the consideration of their genetic unity. Some progress has been made towards explaining this remarkable distribution of languages. In some cases it appears to have originated from mere divergence, continued until practically all traces of original relationship have become obliterated. At any rate, nothing has ever been discovered to support the so-called "fish-trap" theory, according to which the multiplicity of languages in California is due to the successive crowding, into this more desirable habitat, of waves or bands of unrelated immigrants from less favoured regions, to which none of them ever desired to return. This differentiation of speech, again, seems to be casually related to other factors, cultural and historical, and only indirectly physical and environmental.

Much the same is true of the relations of culture and environment, but the latter has been influenced by a long historical development. While, as compared with the rest of America, California forms a well-marked region, on a broader view its distinctive characters largely disappear, or are seen to coincide with such as are typical of the whole of the northern continent. In the north-west the culture seems to be an extension of that of the Pacific coast, while that of the centre and south is of a diverse type.

Archaeological investigation, so far as it has been pursued, does not establish the origin of this culture in Quaternary times or the geological antiquity of those finds which are unquestionably of human origin. The civilisation seems to have remained practically unaltered for some thousands of years; but, at the same time, owing to the prevalence of the practice of cremation, the record of physical anthropology is very incomplete. In the domain of culture much remains to be done, particularly in tracing the relationship of analogous rites among the local tribes. What is needed in all branches of the anthropology of this region is more knowledge, and this can be gained only by more work on the lines of linguistic and anthropological investigation, which it is the main object of this address to illustrate and define.

Progress in Experimental Medicine.

An address on "Tendencies in Pathology" was given by Dr. Simon Flexner, chairman of Section K (physiology

and experimental medicine). Dr. Flexner pointed out that the causation of disease is manifold, the reaction to abnormal influences is varied. The forces which divert the normal functions and bring disease into being are only in part external at the time of their operation. All parasitic plants and animals are essentially extrinsic agents of injury. Occupation diseases, so-called, are at present only slightly understood, and probably act, not only by increasing susceptibility to infections, but also through direct chemical and physical mal-influences. There is, however, a class of diseases which results, in part at least, from errors and disturbances of balance in the development of the animal organism or in the correlation of its functions. The peculiar control which the adrenals exercise over the tone of the vascular system, the degeneration of the aorta in rabbits produced by injection of adrenalin, and the association between sclerosis and atrophy of the kidneys and arterial hypertension and degeneration, suggest that the renal and the arterial disease are parts of one pathological complex. Other instances might be given, e.g. the association of disease of the pancreas with diabetes.

Lately an experimental method has been devised whereby portions of organs and tissues may be transferred from one animal to another, and thus the influences exerted by a new environment on certain organs, or of the transplanted organ on a new host, investigated. For example, it has been found that arteries may be successfully transplanted even after keeping aseptically in a refrigerator for twenty or thirty days after extirpation.

The phagocytic function of the leucocytes, whereby infecting microbes or worn-out somatic cells are ingested and disposed of, is well known, but this function of the living leucocyte is supplemented by its power to yield upon dissolution active proteolytic enzymes of considerable potency, which may have a considerable influence on various pathological processes, e.g. inflammation.

Until recently little progress had been made regarding tumour formation, and we are still ignorant of its cause, but the study of transplantable tumours of mice and rats has already yielded important results concerning the biological conditions underlying tumour growth. Such tumours are highly specific; they are transplantable only to individuals of the same species and race, never to animals of another species, and often not to those of another race of the same species. The existence of a form of immunity to tumour cells has been demonstrated, which may be restricted to one region or may be general to the whole body. This immunity Ehrlich terms *atopsy*, and he conceives it to be an expression of deprivation of the peculiar nutritive stuff required for tumour growth.

As regards bacteriology, one important phenomenon of recent recognition is that of the *microbe carrier*, an individual who harbours disease germs while himself apparently suffering no ill effect. This has been known for some time in the case of the diphtheria bacillus, but has recently been found to hold good for the typhoid bacillus, and for dysentery, plague, cholera, and a host of protozoan infections.

We are now learning, too, that while the forces of immunity may be in active operation, so far as tests made outside the body with the blood indicate, the very bacteria from and against which they have developed may still be surviving in the body.

The discovery of the opsonins in the normal blood, and their increase in states of induced immunity to bacterial and other infections, has added greatly to our knowledge of some of the complicated phenomena of the immune state.

The body infected with bacteria or other pathogenic micro-organisms, although it may survive the infection, may not be rendered more resistant—it may even be rendered more susceptible to the infecting agent or its products. From the diverse reactions of the body to foreign substances and parasitic organisms, phenomena have been discovered, some desirable and beneficial, others objectionable and injurious, and it becomes the quest of the future to secure for medical practice those effects that may be beneficial, and to eliminate those that may be injurious.

COPPER MIRRORS.

METALLIC mirrors have been known from very early times, and references to them are scattered through ancient literature. They were frequently elaborately decorated, and many of them possess the greatest interest as objects of art. Looking-glasses coated with an amalgam of quicksilver and tin came into use about the middle of the fifteenth century, but it is not known by whom they were originally invented. The details of their manufacture were, for long, carefully guarded as trade secrets, and were not made public until about a hundred years later. The process then described is in all essentials that still employed, wherever it has not been abandoned on account of the danger to workers from mercurial poisoning. Tin amalgam mirrors were most extensively used during the latter half of last century, but at the present time in England and Germany they are no longer made, as mirrors obtained by the actual deposition of metallic silver upon glass have displaced them.

This gradual but complete transformation of an important industry had its origin in an observation made by Liebig when investigating the properties of aldehyde, which he had recently discovered. He found that if a solution of silver nitrate to which some drops of ammonia had been added was warmed with the new compound, the silver oxide was immediately reduced, and that the reduction was accompanied by a peculiar phenomenon, the metal attaching itself to the glass in the form of a thin reflecting layer.

Liebig apparently did not at the time realise the importance of his discovery in relation to mirror making. This was first done by Thomas Drayton, of Brighton, who eight years later, in 1843, patented a process for manufacturing looking-glasses by a similar reduction of a silver solution by oil of cloves. His process did not prove a commercial success, and was soon abandoned in favour of one worked out by Liebig, in which milk-sugar was used as the reducing agent, and by various modifications of which all mirrors are now made.

Drayton's method at the time, however, excited widespread interest, and Faraday lectured upon it at the Royal Institution, silversing a number of large glass vessels during the lecture, to the great delight of his audience.

Faraday about this time made the interesting observation that a mirror-like deposit of copper upon glass could be obtained by heating plates of glass in a liquid made by dissolving a little oxide of copper in olive oil. Copper mirrors obtained thus are generally lacking in brilliancy, and if of any size are liable to be stained and discoloured in patches by decomposition products of the oil. Further, as the deposition of the metal only takes place at a temperature above that at which the oil decomposes, the process is excessively disagreeable to carry out, and as the oil is spoiled it is somewhat costly.

The writer has recently discovered¹ that copper can be deposited upon glass from aqueous solution in a film as brilliant as a similarly deposited silver one if a suitable reducing agent be employed. Such a reducing agent is found in phenyl hydrazine, which has the power of readily abstracting oxygen from copper oxide, leaving the copper in the metallic state, and being itself oxidised to benzene, nitrogen, and water.

To obtain a copper mirror by this process it is best to heat a mixture of one part of freshly distilled phenyl hydrazine and two parts of water until a clear solution is obtained, and to add about half its bulk of a warm saturated solution of cupric hydroxide in strong ammonia. Nitrogen is freely evolved during the addition, and the cupric is reduced to cuprous hydroxide, which remains dissolved in the ammoniacal liquid, and does not undergo any appreciable further reduction until heated. A hot to per cent. aqueous solution of potassium hydroxide is next to be added until a slight permanent precipitate of cuprous hydroxide is produced. If the colourless or pale liquid thus made be cautiously heated in contact with a perfectly clean glass surface, metallic copper is deposited upon it in the form of a thin, coherent, perfectly reflecting lamina.

¹ "A Method of Depositing Copper upon Glass from Aqueous Solutions in a Thin Brilliant Reflecting Film, and thus producing a Copper Mirror." Read before the Royal Society, November 21, 1907.

As nitrogen is evolved during the reduction, and as tarry bye-products are formed in small quantity and float with the benzene produced to the surface of the liquid, if flasks or tube are to be coppered, devices must be adopted to keep the inner surfaces completely covered by the liquid from which the metal is being deposited, whilst allowing the gas to escape.

To obtain a film of sufficient thickness to be permanent, it is best to allow it to remain for an hour or so in contact with the warm reducing fluid, and not to pour off the latter until it has cooled to the temperature of the air. The surface of the deposited copper should then be well washed, first with water and afterwards with alcohol and ether, and finally should be protected from the slow oxidising action of the air by one or two coats of some quick-drying varnish.

The mirrors thus formed are very beautiful, for they show the splendid red colour of copper, and are more perfect in reflecting surface than the most highly polished metal. They are, moreover, if properly protected from the air, absolutely permanent. It is interesting to note that the copper is in the monovalent or cuprous state in which it is analogous to silver when it shows a similar capability of being deposited upon glass.

The surface on which the metal is deposited undoubtedly plays an important part in the process, since both silver and copper are deposited much more easily upon surfaces which have not been exposed for any length of time to the action of air or of water, and upon blown than upon polished glass.

It seems probable that the glass surface itself acts as a catalyser, and locally accelerates the reducing action.

F. D. CHATTAWAY.

GEOLOGICAL SURVEY OF CANADA.

SEVEN reports just received from the Geological Survey of Canada afford evidence of the valuable work that is being done in investigating the mineral resources of the Dominion. In Report No. 949 Mr. D. B. Dowling describes the Cascade coal basin, Alberta. He gives an outline of the geology and topography of the coalfield, and a detailed account of the character of the coal, thickness of seams, and extent of the measures. The report is accompanied by eight folding maps. The area illustrated on the map sheets lies within and to the east of the summit of the Rocky Mountains, the formations exposed giving a continuous section from the highest remaining beds of the Cretaceous down to the bottom of the Carboniferous. The coal is of Cretaceous age. In the hills south of the Bow River ten or eleven seams, more than 4 feet thick, have been found, while north of Bankhead, on the slope of Cascade Mountain, fourteen possibly workable seams occur. At the Bankhead colliery the coal is an anthracite, admirably suited for domestic purposes. A screening plant handling 1000 tons a day has been erected. In Report No. 953 Mr. H. S. Poole describes the barytes deposits of Lake Ainslie and North Cheticamp, Nova Scotia, and gives notes on the production, manufacture, and uses of barytes in Canada. Report No. 958 is devoted to Dr. G. C. Hoffmann's review of the work done in the laboratory of the survey during the year. It covers seventy-one pages, and contains a large amount of material of chemical and mineralogical interest. In Report No. 968 Mr. D. D. Cairnes gives an account of the geology of the Moose Mountain area of the disturbed belt of southern Alberta. Coal has been found in several places within this district, and natural gas has been found to the north, south, and east of this area in the same formations as those within it. In Report No. 977 Mr. R. W. Ellis gives an account of the geology and natural resources of the area included in N.W. Quarter-sheet No. 122 of the Ontario and Quebec series, comprising portions of the counties of Pontiac, Carleton, and Renfrew. A lengthy list of fossils from the Chazy, Black River, Trenton, and Pleistocene formations comprised within the area, compiled by Dr. H. M. Ami, is appended. The minerals of economic value met with include iron ore, of which there is a workable deposit at Bristol mines, galena and zinc blende, mica, asbestos,

gold, building stone, molybdenite, brick clays, ochre, and shell-marl. Report No. 971 is devoted to Mr. E. D. Ingalls's statistical review of the mineral industries of Canada for 1905. Although, unfortunately, somewhat belated, this report, which covers 174 pages, gives complete and revised information for the year 1905, advance provisional mineral statistics of which were issued on March 2, 1906.

The grand total of the mineral production of Canada is valued at 13,905,034. The most valuable mineral product is coal, which accounts for 25.2 per cent. of the whole. Metallic minerals contributed together 54 per cent., structural materials 14 per cent., and other non-metallic minerals 5 per cent. Compared with the previous year, substantial increases are shown by all the leading industries, except in the case of gold, due to the continuous decrease of the Yukon placers. An interesting feature is the remarkable increase in the output of cobalt. The large supply of this metal rendered available as a result of the discoveries at Cobalt, Ontario, had, however, a depressing effect on the market, and caused a very marked decrease in price. Lastly, Report No. 1017 is devoted to a summary of the work done by the department of mines, Geological Survey, during the year 1907. It covers 132 pages, and its prompt publication deserves special commendation. There were in the field twenty parties, and the summary reports indicate that a large amount of valuable work was carried out, one of the chief results being the determination of enormous quantities of available bituminous coal in the Yukon region.

UNIVERSITY AND EDUCATIONAL INTELLIGENCE.

Dr. STR. ANDREWS.—After a delay of more than a quarter of a century, at last, by the munificence of Mrs. Bell Pettigrew, the widow of the late professor of medicine and anatomy, a sum of 6000*l.* has been generously offered for the new museum of natural history of the University in which her husband laboured so long. The present museum was erected by the Government in 1846, and whilst its exterior is in keeping with the other substantial buildings in the quadrangle, its mode of lighting and its cases are far behind date. Moreover, its crowded shelves not only render proper exhibition of the specimens impossible, but interfere with classification. In all probability a new lecture-room, a practical class-room, and rooms for curator and workers will be attached to the museum.

CAMBRIDGE.—The essays for which the Smith's prizes are adjudged are as follows (the names are arranged in alphabetical order):—"Problems in the Wave-motion of Viscous Liquids," W. J. Harrison, Clare College; "On the Asymptotic Behaviour of Integral Functions of Zero Order, and Allied Problems," J. E. Littlewood, Trinity College; "On the Solution of Ordinary Linear Differential Equations having Doubly Periodic Coefficients," J. Mercer, Trinity College. The adjudicators are of opinion that the following essays are deserving of honourable mention, viz.:—"On Energy Accelerations and Partition of Energy," C. W. Follett, Trinity Hall;—"On some Problems in the Theory of Metallic Reflection," H. R. Hassé, St. John's College; "The Geometry of Apolar Triads," W. P. Milne, Clare College; "Perpetual Syzygies of the *n*th Kind," H. T. H. Piaggio, St. John's College; "The Reflection of Plane Waves of Light at the Surface of a Medium of Special Periodic Character," C. J. T. Sewell, Trinity College.

J. B. Hubrecht, Christ's College, has been elected to the Isaac Newton studentship, tenable from April 15, 1908, to April 15, 1911. The student will carry on a course of research in solar physics.

H. H. Arnold-Bemrose, Clare College; W. F. Sheppard, Trinity College; J. R. Sutton, Sidney Sussex College; and A. Young, Clare College, have been approved by the general board of studies for the degree of Doctor in Science.

The Vice-Chancellor has announced to the Senate that donations of 1000*l.* each, in memory of the late Mr. Walter K. Foster, have been promised towards the building fund of the new museum of archaeology and of ethnology by

Mrs. Walter K. Foster, Mr. E. Bird Foster, Mr. C. F. Foster, and Mrs. E. Rawlings. Mr. Foster, in whose memory this munificent gift has been made, bequeathed to the University in 1891 an extensive collection of pre-historic and Anglo-Saxon antiquities.

LONDON.—Dr. H. T. Bovey, F.R.S., has been appointed Rector of the Imperial College of Science and Technology at South Kensington. Dr. Bovey was educated at Cambridge. He was twelfth wrangler in 1873, and was elected a fellow of Queen's College. Before going to Canada in 1887 as professor of civil engineering and applied mechanics in McGill University, Montreal, he practised as a civil engineer, being engaged on important works on the Mersey. Under Dr. Bovey's direction the civil engineering department at McGill University acquired a considerable reputation both for undergraduate and research work. Recently a course of study in transportation was added to the seven other engineering courses. The work in this subject is liberally supported by the great Canadian railway companies. In 1888 Dr. Bovey was appointed dean of applied science in McGill University. It is well known that McGill University is excellently equipped both for engineering and applied science. In the chemistry department, for example, there are special laboratories for organic chemistry, physical chemistry, electrolytic analysis, iron and steel analysis, fire assaying, water analysis, determinative mineralogy, petrography, and photography. Dr. Bovey's experience both in engineering and science is therefore exceptionally wide. His literary output includes works on applied mechanics, theory of structures and strength of materials, and hydraulics, in addition to a number of scientific papers. He was elected a Fellow of the Royal Society in 1902.

The London County Council proposes to make a grant of 5000*l.* for the current year to the Imperial College, without, however, pledging itself to contribute 20,000*l.* a year in the future, as was intended if the original scheme for the college, by which it was proposed to establish a well-equipped institution for higher work in applied science and technology, independent of other institutions at South Kensington, had been carried out.

By the will of the late Mrs. Rylands, the Victoria University, Manchester, will receive the sum of 50,000*l.*; Owens College, Manchester, 25,000*l.*; and Mansfield College, Oxford, 10,000*l.*

The *British Medical Journal* announces that Prof. Wilhelm Erb has given the University of Heidelberg a donation of 5000*l.*, one half to be applied for the benefit of students and assistants and their maintenance in hospital when required, the other towards the promotion of scientific research by students.

WE have received from Messrs. Swan Sonnenschein and Co., Ltd., copies of the 1908 issues of "The Public Schools Year-book and Preparatory Schools Year-book" (price 3*s.* 6*d.* net), and "The Schoolmasters Year-book and Directory" (price 7*s.* 6*d.* net). Both books have become well known to educational workers as useful volumes of reference. The annual dealing specifically with the public schools, those, that is, which are connected with the Headmasters' Conference, provides details concerning the public schools which a parent seeking a school for his boy wishes to know. But the book contains much other useful information about preparatory schools, scholarships available, and the public examinations which qualify for entrance into the professions. There is, in addition, a section dealing with the various professions themselves which should prove invaluable to fathers whose sons have completed their school careers. The second volume appeals more directly to schoolmasters and others concerned in the administration of education. The extensive organisations throughout the country for the administration of secondary education are summarised; there is a chronicle of educational events during 1907; and particulars are given about educational societies and publications, examinations and inspecting bodies, and miscellaneous matters. More than half the volume is devoted to a very complete directory providing detailed information concerning the qualifications and experience of masters teaching in secondary schools.

MANY of the numbers in the "Statistics of Public Education in England and Wales, 1905-6-7," recently published (Cd. 3880) by the Board of Education, give useful information as to the condition of our national education during the year 1905-6 and the years immediately preceding. On August 1, 1906, accommodation was provided in the public elementary schools of all grades for 7,008,641 children, of which number of places 3,543,760 were in "council" schools, or, as they were formerly called, "board" schools. In ordinary elementary schools, that is, omitting every kind of "special" school, there were 5,994,490 pupils on the registers and 5,303,229 in average attendance. These children were taught by 31,893 head teachers, 93,130 assistant teachers, and 49,056 "other" teachers. The Government grant to meet expenditure in respect of elementary education during 1906-7 reached 11,248,794*l.*, and in 1905-6 was 10,820,366*l.* In addition, 92,328*l.* was paid in 1906-7 on account of allowances and pensions for teachers, and 552,804*l.* for the training of teachers and pupil-teachers. In secondary schools in receipt of grants from the Board of Education, which in 1905-6 numbered 680, there were in that year 65,994 boys and 49,604 girls, and on 66,014 of these pupils—for grants were only paid on children between twelve and sixteen years of age taking an approved course of work—the sum paid in grants amounted to 246,220*l.* A serious falling off in the number of pupils in secondary schools between the ages of twelve and sixteen years is shown in the statistics. To take one example, the number of boys (about twelve to thirteen years of age) taking an approved course and doing the work of the first year was, in 1905-6, 12,238; doing the second year's work, 9,024; the third year's work, 4,907; and the fourth year's work, 2,397. It would seem that less than 20 per cent. of the boys who at twelve years of age begin the approved course of work remain at school until sixteen years of age, and the same proportion seems to be true in the case of the girls.

SOCIETIES AND ACADEMIES.

LONDON.

Royal Society. November 14, 1907.—"On the Result of Crossing Round with Wrinkled Peas, with Especial Reference to their Starch-grains." By A. D. **Darbishire**. Communicated by Prof. J. Bretland Farmer, F.R.S.

The facts so far brought to light are:—

(i) That, although roundness is dominant over wrinkledness in peas, the starch-grain of the F_2 generation (the round or r -grain) is a blend between the type of grain of the round pea (the potato-shaped or p -grain) and the type of grain of the wrinkled pea (the compound or c -grain) in respect of three characters:—

(a) It is intermediate in shape as measured by its length-breadth index—that of the p -grain being 66, that of the c -grain 92, and that of the r -grain 85 (neglecting decimals).

(b) It is intermediate in the distribution of compoundness, inasmuch as some of the r -grains are compound and some single.

(c) It is intermediate in the degree of compoundness, inasmuch as amongst those r -grains which are compound the most usual number of constituent pieces is three, whereas in c -grains it is six.

(2) In a subsequent generation— F_3 —the homozygote round peas contain p -grains; the heterozygote round peas contain r - or intermediate grains. But both r - and intermediate grains may be associated either with a high or with a low degree of compoundness.

(3) p -Grains occasionally occur in wrinkled peas in F_3 , and the evidence suggests that the existence of these grains in wrinkled peas tends to make them less wrinkled.

(4) A wrinkled pea takes up more water when it germinates than a round one. The hybrid between a round and a wrinkled pea is intermediate in respect of his character between its two parents.

But this intermediateness of the hybrid in absorptive capacity is not occasioned by the intermediateness of the starch-grain of the hybrid, because, in F_3 , peas containing p -grains and peas containing c -grains both have the same absorptive capacity as the F_1 pea.

(6) When, therefore, we cross a round with a wrinkled pea, we are dealing with four separately heritable characters:—

(i) The shape of the pea—whether round or wrinkled.

(ii) The absorptive capacity of the pea—whether low or high.

(iii) The shape of the starch-grain—whether long or round.

(iv) The constitution of the starch-grain—whether single or compound.

"On the Inheritance of Eye-colour in Man." By C. C. **Hurst**. Communicated by W. Bateson, F.R.S.

An examination of the eye-colours of a number of parents and their offspring in a Leicestershire village shows that there are at least two discontinuous types of iris in man:—

(i) The duplex type, with both anterior and posterior pigments, as in ordinary brown eyes.

(2) The simplex type, with posterior pigment only, the anterior pigment being absent, as in clear blue eyes.

In heredity the simplex type behaves as a Mendelian recessive to the duplex type, which is dominant. The unit characters concerned are evidently presence (duplex) and absence (simplex) of anterior pigment on a basis of posterior pigment, presence being dominant.

The duplex and simplex types can be distinguished at any age. Various pigmental and structural changes take place in the iris during childhood and youth, the extent of which is not yet known. Few families with living parents and offspring, all adult, are to be found in one village. Consequently, it has not yet been possible to determine the genetic relations between the various shades of the duplex type.

Mathematical Society, February 12.—Prof. W. Burnside, president, in the chair.—A proof that every algebraic equation has a root: Dr. H. A. de S. **Pittard**.—Note on g -differences: F. H. **Jackson**.—An extension of Eisenstein's law of reciprocity (second paper): A. E. **Western**.

—Conformal representation and the transformation of Laplace's equation: E. **Cunningham**.—The uniform approach of a continuous function to its limit: Dr. W. H. **Young**.

Physical Society, January 24.—Prof. J. Perry, F.R.S., president, in the chair.—Observations on rescalence curves: W. **Rosenhain**. Referring to the importance of the accurate study of rescalence phenomena in metals and alloys, the author describes the two principal methods employed for obtaining rescalence curves. These are known as the "inverse rate" and "differential" methods respectively.

In the former method the times occupied by successive equal decrements of temperature are observed and plotted against the temperature of the cooling body, thus giving a curve the ordinates of which are temperature (t) and dT/dt (T =time) respectively. In the differential method the difference of temperature between the body under observation and a neutral or "blank" body cooling under approximately the same conditions is observed and plotted against the temperature of the body. The physical interpretations, in terms of quantity of heat evolved and of rate of evolution of heat of these two kinds of curves, are discussed by reference to the fundamental curve representing the time-temperature relations of one or two cooling bodies. Finally, the author describes a rescalence first observed to occur somewhat mysteriously in the body of certain furnaces at a temperature of 580° C. This was ultimately traced to a transformation occurring in crystalline silica, whether free or in admixture with porcelain or fire-clay. The author points out that this rescalence in crystalline silica coincides with certain points in the iron-carbon diagram of Roberts-Austen and of Carpenter and Keeling, and suggests that the rescalences observed by those workers may have arisen from silica in their furnaces.

Society of Chemical Industry, February 3.—Dr. J. Leuckowitsch in the chair.—Nitroglycerine and its manufacture: Lieut.-Colonel Sir F. L. **Nathan** and W. **Rintoul**. The discovery and properties of nitroglycerine were described, and particulars were given of improvements which have been effected in methods of manufacture.

Chemical Society, February 6.—Sir William Ramsay, K.C.B., F.R.S., president, in the chair.—The metallic picrates: O. **Silberrad** and H. A. **Phillips**. The water of crystallisation and properties of the commoner picrates have been definitely established.—Some physicochemical properties of mixtures of pyridine and water: H. **Hartley**, N. G. **Thomas**, and M. P. **Applebey**.—The constitution of umbellulone, part iii.: F. **Tutin**. A refutation of Semmler's recent statements (*Ber.*, 1907, xl., 5017) respecting the constitution of umbellulone.—Colour and constitution of azomethine compounds, part i.: F. G. **Pope**. The nitrohydroxyazomethine compounds show an entirely different absorption spectrum from that of their alkali salts when the nitro- and hydroxyl groups are in the *para* position to the azomethine group, and from the similarity of the *N*:CH₂ grouping to the *N*:N grouping it would seem that the alkali salts of these compounds could be formulated on a di-quinonoid basis, the free hydroxyl compounds being represented thus:—



and the alkali salts as



(compare Hewitt and Mitchell, *Trans.*, 1907, xci., 1251).—The preparation of *l*-benzoin: A. **McKenzie** and H. **Wren**.—Organic derivatives of silicon, part v., benzyl-ethylsilicone, dibenzylsilicone, and other benzyl and benzylethyl derivatives of silicane: R. **Robison** and F. S. **Kipping**. Descriptions of these silicon derivatives are given.—The residual affinity of the coumarins and thiocoumarins, as shown by their additive compounds: A. **Clayton**. The coumarins and thiocoumarins combine with mercuric chloride, forming compounds of the type R.HgCl₂, where R is a coumarin or a thiocoumarin.—The influence of foreign substances on certain transition temperatures, and the determination of molecular weights: H. M. **Dawson** and C. G. **Jackson**. The changes investigated were:—

- (1) Na₂S₂O₅·5H₂O → Na₂S₂O₅·2H₂O at 48°·1;
- (2) NaBr·2H₂O → NaBr at 50°·67; and
- (3) CaCl₂·6H₂O + 2MgCl₂·6H₂O → CaCl₂·2MgCl₂·12H₂O at 22°·4.

Constants representing the depression of the transition temperature when one gram-molecule of the foreign substance is contained in 100 grams of the saturated transition solution have been calculated. From a knowledge of these constants, the corresponding invariant points may be utilised for the purpose of obtaining the molecular weights of dissolved substances.—The bromination of *p*-hydroxydiphenylamine: Miss A. E. **Smith** and K. J. P. **Orton**.—The decomposition of ammonium dichromate by heat: W. M. **Hooton**. If the salt is decomposed slowly by heat, the final product is hydrated chromium dioxide, 2Cr₂O₃·H₂O, a glistening black powder which when heated yields oxygen, water, and chromium sesquioxide. If ammonium dichromate is heated in absence of oxygen, the final product is a dull, greenish-black powder having the composition H₂Cr₂O₄.—The effect of constitution on the rotatory power of optically active nitrogen compounds, part ii.: H. O. **Jones** and J. R. **Hill**.—Malacone, a silicate of zirconium: A. C. **Cumming**. The author finds that the formula ZrO₂·SiO₂ corresponds more closely with the observed composition of malacone than does the formula 3ZrO₂·2SiO₂ assigned to it by Kitchin and Winterson (*Trans. Chem. Soc.*, 1906, lxxxix., 1568).—The reducibility of magnesium oxide by carbon: R. E. **Stade**. The isolation of magnesium by direct reduction of the oxide by carbon has been effected at temperatures above 1700°. Rapid evacuation of the vessel in which the reaction occurs, absorption of the magnesium by molten copper, and reduction of magnesia in presence of aluminium or in a swift stream of hydrogen have all proved useful in preventing the reverse reaction, which occurs between magnesium and carbon monoxide.—The crystal form of halogen derivatives of open chain hydrocarbons with reference to the Barlow-Pope theory of structure: F. M. **Jaeger**. In accordance with the theory of Barlow and Pope, it is found that tetrabromo-*ββ*-dimethyl-

propane, 1,3:5-hexatriene, di- and tetra-bromide, and tetradodecathylene exhibit a close morphotropic relationship.—The determination of the rate of change by measurement of the gases evolved: F. E. E. **Lampough**.—The temperatures of spontaneous crystallisation of mixed solutions, and their determination by means of the index of refraction. Mixtures of solutions of sodium nitrate and lead nitrate: Miss F. **Isaac**.—Contributions to the chemistry of the terpenes, part iii.; some oxidation products of pinene: G. G. **Henderson** and I. M. **Heibron**.—A *β*-lactonic acid from acetone and malonic acid: A. N. **Meldrum**. When malonic acid and acetone are mixed with acetic anhydride and a little sulphuric acid, the *β*-lactone of *β*-hydroxyisopropylmalonic acid,



is formed.

PARIS.

Academy of Sciences, February 10.—M. H. **Bequerel** in the chair.—The spectra of non-dissociated compounds: Henri **Bequerel**. A reply to a recent note of M. A. **Dufour**, and pointing out the connection between the results of M. Dufour and certain phosphorescent and absorption spectra.—The alcoholysis of linseed oil: A. **Haller**. The author has applied his method of saponification with alcoholic hydrochloric acid to the preparation of the methyl esters of the fatty acids contained in linseed oil. These methyl esters were submitted to fractional distillation under reduced pressure, and the distillates caused to crystallise at -7° C. In this way the methyl esters of stearic, palmitic, and arachic acids were separated in a pure state.—Parthenogenesis at Roscoff and at Berkeley: Yves **Deslago**. A controversial paper in reply to Loeb.—The dispersion of light in interstellar space: Charles **Nordmann**. A sketch of a new method for determining if rays of different wave-lengths all travel in interstellar space with the same velocity, based on the monochromatic photometry of a variable star. The experimental results will be given in a later paper.—Observations of the transit of Mercury of November 14, 1907, made at the Royal Observatory of Belgium: M. **Lecoqte**. Results are given for the observations of the contacts, the form of the disc, and observations of position and of physical appearance.—Theorem on Taylor's series: Michel **Petrovitch**.—The approximate integration of differential equations: Emile **Cotton**.—The diminution of the rolling of ships: V. **Crémieu**.—A new series of ammoniacal ferric salts in which the iron is masked: P. **Pascal**. A description of some complex salts formed by the addition of ammonia to solutions of sodium ferripyrophosphate.—The silicide of magnesium: Paul **Lebeau** and Robert **Bossuet**. Alloys of magnesium and silicon containing from 0.38 per cent. up to more than 50 per cent. of silicon were examined micrographically. From the results of this examination it appeared that there exists only one magnesium silicide containing less than 40 per cent. of silicon. Aqueous solutions proved to be useless for the isolation of the silicide from the ingot, and the excess of magnesium was removed by the action of ethyl iodide and ether. The compound thus isolated was SiMg₂, and gives hydrogen free from hydrogen silicide when acted upon by water. Hydrochloric acid attacks it energetically, a mixture of hydrogen and spontaneously inflammable hydrogen silicides being produced. The compound is completely dissociated in a vacuum at 1100°–1200° C., the magnesium being volatilised.—The colloidal properties of starch, and on the existence of a perfect solution of this substance: R. E. **Fouard**. The starch solution was filtered through a membrane of collodion, and its properties were totally different from ordinary starch solutions. The strength of the solution was 2.74 per cent. of starch; it was clear and perfectly transparent, and an intense light bundle after passing through the solution showed no trace of polarisation. The viscosity of a 1 per cent. solution was of the same order of magnitude as water or 1 per cent. sugar solution, and only one-twelfth that of a 1 per cent. starch solution made in the ordinary way.—The state of the camphorcarbonates of the fatty and aromatic amines in solution, as shown by the rotatory power: J. **Minguin**.—Researches on the physical

modifications of gelatin in presence of electrolytes and non-electrolytes; J. Larguier **des Bancels**. In presence of certain salts gelatin dissolves in water at the ordinary temperature. At equal concentrations, salts of divalent metals exert a more powerful solvent action than salts of monovalent metals. For the same metals nitrates exert a more energetic action than chlorides. Certain non-electrolytes, such as alcohol or acetone, also attack gelatin more easily than pure water.—The rapid estimation of potassium bichromate in milks; M. **Gouëre**.—The preparation of dithymol; the action of bromine on dithymol. II. **Cousin** and H. **Hérissey**. The oxidation of the thymol is carried out with ferric chloride in aqueous solution; the yield is from 25 per cent. to 30 per cent.—7-Oxytetrolic acid; MM. **Lespieau** and **Viguier**. This is prepared by the interaction of propargyl alcohol and ethylmagnesium bromide, the reaction product being treated with carbon dioxide. The addition products with bromine have been studied.—Researches on a method of preparing the cyclic aldehydes; M. **Savariou**. Phenylmagnesium bromide reacts with chloral hydrate to give the compound $C_6H_5.CH(OH).CCl_2$, and this is converted into benzaldehyde by boiling with a solution of an alkaline carbonate. The method appears to be general, and may be useful in preparing small quantities of rare cyclic aldehydes.—The action of alcohols upon sodium benzoate; Marcel **Guerbet**. The action of sodium benzoate upon benzyl alcohol at 225° C. gives rise to stilbene, dibenzyl, toluene, and benzoic acid.—The chemical constitution and biological properties of the protoplasm of Koch's bacillus; Jules **Auclair** and Louis **Paris**.—Tyrosinase and racemic tyrosine; Gabriel **Bertrand** and M. **Rosenblatt**.—The genus *Seuratia* and its connections with *Capnodium*; Paul **Vuillemin**.—The intramolecular respiration of the aerial vegetative organs of vascular plants; G. **Nicolas**.—The multiplication *in vitro* of *Treponema pallidum*; C. **Lebailly**.

DIARY OF SOCIETIES.

THURSDAY, FEBRUARY 20.

ROYAL SOCIETY, at 4.30.—Notes on the Application of Low Temperatures to some Chemical Problems. (1) Use of Charcoal in Vapour Density Determination. (2) Rotatory Power of Organic Substances; Sir James Dewar, F.R.S., and Dr. H. O. Jones.—On the Osmotic Pressure of Compressible Solutions of any Degree of Concentration. Part II. Cases in which both Solvent and Solute are Volatile; A. W. Porter.—Effects of Self-induction in an Iron Cylinder when traversed by Alternating Currents; Prof. Ernest Wilson.—(3) On the Refractive Indices of Gaseous Nitric Oxide, Sulphur Dioxide, and Sulphur Trioxide. (c) On the Distribution of Gaseous Mercury, Sulphur, Phosphorus, and Helium; C. Cuthbertson and E. Parr Metcalf.

ROYAL INSTITUTION, at 3.—Wood; its Botanical and Technical Aspects; Prof. W. Somerville.

INSTITUTION OF MINING AND METALLURGY, at 8.—The Alloys of Gold and Tellurium; Dr. T. K. Rose.—A Method of Settling Slimes, as applied to their Separation from Solution in Cyanide Treatment; H. G. Nichols.—Two Determinants to the Dissolution of Free Gold in the Cyanide Process; Dr. Simpson.—A Rapid Method for the Estimation of Arsenic in Ores; H. E. Hooper.—The Indian Mint Assay of Silver Bullion; F. T. C. Hughes.

LIVERNEAN SOCIETY, at 8.—Experiments with Wild Species of Tube-bearing Sponges; A. W. Sutton.—The Life-history and Larval Habits of Tiger Beetles (Cicindela); Dr. V. E. Shelford.—On a Possible Case of Mimicry in the Common Sloe; Dr. A. T. Masterman. *Exhibiti*: Stereoscopic Photographs of Alpine Plants in Natural Colours; T. Ernest Wulham.

INSTITUTION OF ELECTRICAL ENGINEERS, at 8.—Electrical Power in Railway Goods Warehouses; H. Henderson.—Electric Power in Docks; C. E. Taylor.

CHEMICAL SOCIETY, at 8.30.—The Action of Thionyl Chloride and of Phosphorus Pentachloride on the Methylene Ethers of Pyrocatechol Derivatives; G. Barber.—The Preparation of Conductivity Water; H. Hartley, N. P. Campbell and K. H. Poole.—Derivatives of *para*-Diazobenzene; G. T. Morgan and Miss F. M. G. Micklethwait.—A Study of the Diaz-reaction in the Diphenyl Series; G. T. Morgan and Miss F. M. G. Micklethwait.—Organic Derivatives of Silicon. Part VI. The Optically Active Sulphobenzylethylpropylsilyl Oxides; F. S. Kipping.—A Simple Manometer for Vacuum Distillation; N. L. Gebhard.

FRIDAY, FEBRUARY 21.

ROYAL INSTITUTION, at 9.—The Ether of Space; Sir Oliver Lodge, F.R.S.

INSTITUTION OF MECHANICAL ENGINEERS, at 8.—Annual Meeting.—Tests of a Live Steam Feed-water Heater; Prof. J. Goodman and Dr. B. MacLachlan.

INSTITUTION OF CIVIL ENGINEERS, at 8.—Currents as a Cause of Coastal Erosion; G. O. Case.

MONDAY, FEBRUARY 24.

ROYAL SOCIETY OF ARTS, at 8.—The Theory and Practice of Clock Making; H. H. Cuyveland, C.B.

ROYAL GEOGRAPHICAL SOCIETY, at 8.30.—Travels in the Old Kingdom of Coe; Rev. Thomas Lewis.

INSTITUTE OF ACTUARIES, at 5.—A Review of the Investments of Offices in Recent Years, with Notes on Stock Exchange Fluctuations and the Future Rate of Interest; P. I. Newman.

TUESDAY, FEBRUARY 25.

ROYAL INSTITUTION, at 3.—Membranes: Their Structure, Uses and Products; Prof. W. Stirling.

ROYAL SOCIETY OF ARTS, at 4.30.—Irrigation in Egypt under British Direction; Sir Hugh Browne, C.B.

ROYAL ANTHROPOLOGICAL INSTITUTE, at 8.15.—Montenegrin Manners and Customs; Miss M. Edith Durham.

INSTITUTION OF CIVIL ENGINEERS, at 8.—The New York Rapid-transit Subway; W. B. Parsons.

FARADAY SOCIETY, at 8.—Hydrolysis as Illustrated by Heats of Neutralisation; Dr. V. H. Veley, F.R.S.—A Study of the Sulphur Anion and of Complex Sulphur Anions; Dr. J. Knox.

WEDNESDAY, FEBRUARY 26.

ROYAL SOCIETY OF ARTS, at 8.—The Problem of Road Construction with a View to Present and Future Requirements; H. S. Hele-Shaw, F.R.S., and Douglas Mackenzie.

BRITISH ASTRONOMICAL ASSOCIATION, at 5.—Address by Prof. H. H. Turner, F.R.S.

THURSDAY, FEBRUARY 27.

ROYAL SOCIETY, at 4.30.—*probably* *1907*—The Influence of Temperature on Phagocytosis; J. C. G. Ledingham.—On the Maturation of the Ovum in the Guinea-pig; Prof. J. E. S. Moore and Miss F. Twort.

ROYAL INSTITUTION, at 3.—Wood; its Botanical and Technical Aspects; Prof. W. Somerville.

ROYAL SOCIETY OF DYERS AND COLORISTS, at 8.—The Deterioration of Modern Dyed Leathers; M. C. Lamb.—A Note on the Germicidal Value of Petroleum Benzene; F. J. Farrell and F. Howles.

FRIDAY, FEBRUARY 28.

ROYAL INSTITUTION, at 9.—Explosive Combustion, with Special Reference to that of Hydrocarbons; Prof. W. A. Bone, F.R.S.

ROYAL SOCIETY OF ARTS, at 8.—The Removal of Dust and Fumes in Factories; Dr. J. S. Haldane, F.R.S.

PHYSICAL SOCIETY, at 5.—Contact Potential Differences Determined by Means of Null Solutions; S. W. J. Smith and H. Moss.—An Experimental Examination of Gibbs' Theory of Surface Tension as the Basis of Adsorption with an Application to the Theory of Dyeing; Mr. Lewis.

CONTENTS.

PAGE

Continuation Schools. By Prof. J. Wertheimer . . .	361
Iceland Past and Present. By M. G. B.	362
Advanced Organic Chemistry. By F. M. P.	363
Our Book Shelf:—	
Fox-Strangways: "The Geology of the Leicestershire and South Derbyshire Coalfield"	364
Lewis: "Inorganic Chemistry"	364
Ball: "Altitude Tables"	365
Shepherd: "Problems in Strength of Materials"; "Whittaker's Arithmetic of Electrical Engineering for Technical Students and Engineers"	365
Richmond: "An Essay upon Disease: its Cause and Prevention"	365
Letters to the Editor:—	
Radium and the Earth's Heat.—Prof. Harold A. Wilson, F.R.S.; Hon. R. J. Strutt, F.R.S.	365
Ground Ice.—James Thomson	366
The Stresses in Masonry Dams. (<i>With Diagram</i>).—Prof. Karl Pearson, F.R.S.	366
The Inheritance of "Acquired" Characters.—J. T. Cunningham	367
Technical Research and the College System.—W. P. Dreaper	367
A Variation in Amoeba.—M. D. Hill	367
An Alleged Originator of the Theory of Atoms.—Dr. J. L. E. Dreyer	368
Notes on Ancient British Monuments. V.—	
Avenues (<i>continued</i>). (<i>Illustrated</i>). By Sir Norman Lockyer, K.C.B., F.R.S.	368
A Study of the River Trent. (<i>Illustrated</i>).	371
The Sun and the Clock	372
Irish Fishery Investigations	373
Notes	373
Our Astronomical Column:—	
The Recent Spectrum and Magnitude of Nova Persei No. 2	377
The Helium Line, D ₃ , as a Dark Line in the Solar Spectrum	377
A Detailed Study of the Photosphere	378
Sectional Addresses at the Chicago Meeting of the American Association	378
Copper Mirrors. By Dr. F. D. Chattaway, F.R.S.	380
Geological Survey of Canada	380
University and Educational Intelligence	381
Societies and Academies	382
Diary of Societies	384

THURSDAY, FEBRUARY 27, 1908.

MAN AND NATURE IN SOUTH-WEST AFRICA.

Aus Namaland und Kalahari. By Prof. Leonhard Schultze. Pp. xiv + 752. (Jena: Gustav Fischer, 1907.) Price 60 marks.

THE scope of this admirable work on Namakwaland and the Kalahari has not any knowledge of political boundaries. Neither is it confined to ethnology or biology. Its range extends over a portion of British Bechuanaland and northern Cape Colony, and it deals slightly with the northern parts of German South-West Africa—Damaraland and the Ovambo countries. It is such a book as can as yet only be published in Germany. The reproduction of Dr. Schultze's photographs of human types, landscapes, birds, and beasts is simply perfection, the photographs themselves being without blemish. Where it has been necessary to make and reproduce drawings in lieu of photographs, these are of great beauty and accuracy, and their reproduction is of a quality apparently unattainable in England.

To summarise the principal subjects of the book. The geological features of the south-west coast of Africa are illustrated with many photographs, diagrams, and a careful verbal description. This, though thoroughly scientific, may appeal likewise to the eyes and intelligence of the unlearned. The set of the currents, the growth or diminution of the sand-bars along the coast, the caves (once, perhaps, inhabited by the primitive tribes of Strandloopers), the barren, rocky coast, with its beaches strewn with whalebones, the rocky capes with great maned sea-lions *in situ*, the islets, thick with cormorants, gannets (literally in millions), and penguins, are graphically depicted. An interesting record of the species of whales recorded on this coast, as well as of the principal sea fish, molluscs, and other water animals, is given on pp. 30 to 41. The author supplies the Hottentot names for all creatures or features recognised by the natives.

Though vegetation is not the strong point of this desolate region, such as is found there is of great interest to the botanist owing to its special adaptation to arid conditions of life. The *Zygyophyllums* (characteristic of the northern desert from Senegal to Scinde), the soap bushes (*Salsola*), the *Mesembrianthemums*, with their cactus-like flowers and thick segmented stalks, the stumpy euphorbias, gouty, branched aloes, and that extraordinary plant the *Welwitschia mirabilis*—almost every example of this strange desert vegetation is represented by photographs of remarkable clearness and beauty. The camera also shows us the large-eared, chamois-like *Raphicerus* antelopes, perched on the jagged summits of honeycombed gneiss; vast river plains surrounded by monotonous ranges of table-top mountains, but exhibiting some relief from the universal desert in the acacias, *Boscias*, *Bauhinias*, *Baphias*, *Combretums*, gourd, lilies, rushes, and euphorbias they nourish. (One exquisite picture opposite p. 604 shows an erstwhile desolate stretch of the Kalahari Desert temporarily lovely with thick masses of the *Brusvigia* lilies.) The black-

backed jackal, the Chakma baboon, the ostrich, Cape hartebeest, porcupine (the South African species), the steenbock (*Raphicerus*), the white-tailed gnu, zebra, springbock, giraffe, lion, and all important members of the mammalian fauna, past and present, are illustrated by photographs from the living animal. From p. 268 to p. 288 a great deal of information is given about the existing mammalian fauna of the interior. The elephant is included, though it is practically extinct in this region, and only remains in the traditions of the Hottentots. The white rhinoceros is known by name, but is now extinct. The same fate has also probably reached the common black rhinoceros, and the quagga likewise only lingers in traditions. (The last quagga of South-West Africa appears to have been killed in 1880.) The strangely archaic dog form—*Otocyon*—with its four molar teeth on either side of the lower and sometimes of the upper jaw, is fairly common in Namakwaland and the Kalahari Desert. Dr. Schultze observes that it never goes in packs, but leads a solitary existence. The brown hyæna (*H. brunnea*) is apparently found in South-West Africa, as well as the spotted hyæna, but the Hottentots do not seem clearly to distinguish in nomenclature between the two forms.

The supreme interest of this work lies in the descriptions and illustrations of the Hottentot, Bushmen, and Berg-damara peoples. Portraits of the Herero and of the Barolong-Bechuana are also given to contrast the Bantu type with the very distinct Hottentot and Bushman. There are also pictures and descriptions of the Masarwa Bushmen, which would suggest that these last are due to some slight intermixture with the intruding Bantu.

Opposite p. 420 there are two photographs of the Berg-damara. This is a mountain people found in the northern part of Namakwaland. They speak a language which is obviously Hottentot, but in physical type they are entirely unlike the Hottentot, except that both are widely divergent forms of the negro species. The Berg-damaras are a tall people compared to the Hottentots, and hairy about the body, with abundant head hair, and, in the males, full beard and moustache. In shape of head and degree of prognathism they exhibit a good deal of variety. There are old photographs in the possession of the Royal Geographical Society (dating from the Palgrave expedition of 1873) which exhibit types of Berg-damara of quite a simian aspect, strongly reminiscent of the most primitive tribes of forest negroes in the Congo basin. On the other hand, the Berg-damara people seen by the writer of this review in South-West Africa in 1882, and illustrated in this book, represent a fairly good-looking type of Bantu negro, and might be matched easily among the Bantu tribes of the southern and eastern Congo basin.

Any doubt as to the ape-like faces of the pure-blood Bushmen is dispelled by a glance at the pictures opposite p. 322. On the other hand, some of the Hottentot types herein illustrated suggest what is no doubt the obvious solution of their origin—an ancient hybrid between the pure Bushman stock and some Nilotic negro race in the east of Africa, with a dash

here and there of the forest negro. There has also been an obvious intermixture of blood between the eastern Hottentots and the incoming Bantu, and some of the pictures of Hottentot boys are singularly reminiscent of the Nyanja populations of western and southern Nyasaland, regions that certainly once possessed a Hottentot or Bushman population. The extraordinary steatopygy developed by the Hottentot women, and occasionally the men, to a degree not met with in any other part of Africa (though by no means unknown among Nilotic or Sudanese negroes, and apparently characteristic of a primitive negroid population of Egypt and the Mediterranean basin) is also illustrated by photographs and verbal description.

What strikes one markedly in the Bushman types and some of the Hottentots is the superficial resemblance they bear in features to the peasant population of parts of central Europe, eastern France, and—if one may dare to say so—some parts of Ireland.¹ It is quite possible that the Bushman type of negro once ranged from central and western Europe, across the Mediterranean, and down the east side of Africa to his present habitat. It is curious that these types do not recall any reminiscences of the Congo pygmy or the West African negro. One is only able to match them in the eastern Sudan and in Europe. The author directs attention to the fact that the Bushmen and Hottentots, where they are uninfluenced by the Bantu, do not practise circumcision.

They are scarcely in an age of stone; indeed, Dr. Schultze does not seem to record the use of any stone implements. But they are living in an age of bone, wood, and skins. The arrow-heads of the Bushmen are usually made of bone. So are many other implements of Bushman and Hottentot. Wood and leather, gourds, thorns, and sticks are the materials out of which utensils, ornaments, and receptacles are made.

Among the many aspects of the life of these primitive peoples so completely illustrated in this work are the domestic animals—sheep, goats, and cattle. The dog no doubt migrated south with the Bushman and Hottentot, after a previous sojourn in the Mediterranean basin. But obviously, the goat first, then the ox and the sheep, were brought to them from the north by Bantu or Nilotic negroes. The Hottentot root word to express cattle (*goma*) is probably derived from the southern Bantu *-komo*, and *biri*-, for goat, may be the early Bantu *buri*, *budi*. Even the vocable for sheep, *gu*-, can be traced to a Bantu source.

The cattle of these regions, whether belonging to Hottentot or Bantu peoples, are apparently a mixture between breeds introduced two and three hundred years ago by the Portuguese and the Dutch and the two more or less indigenous breeds of Central Africa, that is to say, the humped ox (*Bos indicus*) and the Gala or Egyptian ox (*Bos aegyptiacus*), with its enormous horns. Nowhere amongst the herds of any of the southern Bantu or of the Hottentot does one meet with the typical African ox that formerly ranged from Egypt across the Sudan to Senegambia, and which has penetrated to the mountain regions of the

Nil and Congo basins. In this ox of pure breed the horn cores are never set horizontally and curved forward over the face; they grow out at right angles from the frontal line, and then upwards and backwards. It is evident that the cattle introduced from western and northern Europe considerably modified the stock of the South and South-West African breeds.

The Hottentot language is profoundly studied in the volume under review. There is a vast deal of information about folklore, rainfall, and temperatures, lists of plants, the musical notation of Hottentot songs, chemical analyses of Hottentot medicines, and a bibliography.

If this is the way in which Germany is going to illustrate her colonies, the world of science would gladly install her in possession of all the backward and little-known regions of the world.

H. H. JOHNSTON.

ALCOHOL AND ITS EFFECTS.

Alcohol and the Human Body. By Sir Victor Horsley, F.R.S., and Dr. Mary D. Sturge, with a Chapter by Dr. Arthur Newsholme. Pp. xvi+370. (London: Macmillan and Co., Ltd., 1907.) Price 5s. net.

THE importance of the alcohol question to the well-being of the race can scarcely be exaggerated, and in many respects this book will be very useful, but it is questionable whether the authors do not go too far in ascribing to alcohol ill effects only and no useful properties. The book, in fact, is a partisan one, and any evidence favourable to alcohol has been completely suppressed.

In the first chapter the action of alcohol as a drug is considered, and it is shown how the use of alcohol has declined in hospitals. The chemistry of alcoholic beverages is then briefly discussed. The effects of alcohol on protoplasm, on the various tissues of the body, and on mental and physical work, are subsequently described in language which can be understood by all, technical terms being avoided, and in the final chapter Dr. Newsholme discusses statistically the influence of the drinking of alcoholic beverages on the national health and wealth.

In venturing to make some criticisms on the book as a whole, we would remark that we are in complete sympathy with the object of the authors, which is, we take it, to emphasise the disastrous consequences which may result from indulgence in alcohol.

The first criticism we would offer is that no distinction is made between alcohol and alcoholic beverages. It may be true that alcohol, as alcohol, does not possess all the virtues and properties which are so often attributed to it; but surely there is a consensus of opinion that the moderate use of good, well-matured spirit or wine is frequently beneficial in some disease conditions, and many of the ills attributed to alcohol may well be due to the by-products present in cheap beverages. Alcohol has been shown to occur in small quantities in the tissues; it is a result of normal metabolism; and we therefore question whether the moderate use of alcoholic beverages does any harm. The difficulty is, of course,

¹ A point which hardly needs to be reminded that Ireland contains at least two distinct anthropological types, ranging from the language to the type of European peoples.

to define what is meant by "moderate use"; probably a quantity of a beverage equivalent to 1 to $1\frac{1}{2}$ fluid ounces of absolute alcohol is as much as can safely be consumed *per diem*. If this be admitted it must be confessed that a large proportion of so-called moderate drinkers exceed the mark; the man who takes four or five whiskies a day is probably consuming 2 to 3 ounces of absolute alcohol *per diem*, and is therefore exceeding what may be considered to be a safe limit. The experiments quoted, in which even weak solutions of alcohol are shown to be protoplasmic poisons, are hardly convincing as to the deleterious action of alcohol on the organism as a whole, for are not distilled water, 3 per cent. salt solution, and beef-tea similarly protoplasmic poisons? A good deal is made of the supposed disastrous effects of alcohol on the nervous system, and it is stated that alcohol is accountable for 20 per cent. of the cases under care in our asylums. Dr. Mott,¹ however, says—and he has made the subject one of special study—that "alcohol does not *per se* produce a permanent mental derangement, such as constitutes our definition of insanity," and he points out that in an American inquiry into the subject, total abstinence was found to be more frequently an antecedent of insanity than was intemperance. These quotations show how difficult it is to associate cause and effect.

Dr. Newsholme deduces from the statistics of the consumption of alcoholic drinks in 1904 that each adult of the working class spends 2s. $2\frac{1}{2}$ d. a week on alcoholic beverages; and, assuming that each family spends 5s. a week, this, if placed as an insurance premium, commencing at the age of 25, would mean that the husband would have saved the sum of 422l. at the age of 55, which, invested as an annuity, would yield 12s. 6d. a week. These are certainly figures of grave import, and we would commend them to the politicians, for here surely is the basis for a scheme of old age pensions!

We doubt, however, if there would actually be anything like this saving, for a majority would certainly spend the money on substitutes for alcoholic beverages—tea, coffee, cocoa, milk, and temperance drinks—on better food and clothing, and on amusements, and the actual gain would, principally be in the well-being of the people. Finally, incidence of sickness and the percentage death rate among abstainers and non-abstainers is contrasted; among the former the death rate is 3'557, among the latter 6'332. Dr. Newsholme remarks:—"We are compelled to conclude that what is commonly described as moderate drinking has a most injurious effect on health and life." We feel convinced that the whole story is not told by these figures. No doubt many drunkards were included among the moderate drinkers (as Dr. Newsholme suggests), and probably a large proportion were not moderate drinkers according to our definition; and may it not be that a considerable proportion of naturally delicate persons, persons whose stamina is poor and who suffer from various ailments and tend to die young, are moderate drinkers, while the

abstainers include a large proportion of robust individuals who do not feel the need for any alcohol?

On the other hand, a number of so-called abstainers are certainly really moderate drinkers, for many temperance drinks contain some alcohol. Thus, in the year ending March 31, 1907, of 1133 samples of beverages sold as temperance drinks examined in the Government Laboratory, 71 contained 3 per cent. of proof spirit, 37 contained 4 per cent., and 8 contained 6 per cent. or more. Herb beer and dandelion stout contained respectively 10'5 per cent. and 12'3 per cent. of proof spirit. That is to say, 10 per cent. of temperance drinks contain nearly as much alcohol as a mild ale!

The book is well got up, and contains a number of coloured and black-and-white illustrations and diagrams.

VAN DER WAALS AND HIS SUCCESSORS.

Die Zustandsgleichung der Gase und Flüssigkeiten und die Continuitätstheorie. By Prof. J. P. Kuenen. Pp. x+241. (Brunswick: F. Vieweg und Sohn, 1907.) Price 6.50 marks.

PROF. KUENEN'S monograph will be welcomed by a large circle of readers who have felt the fascination of van der Waals's equation in its simple but marvellous exposition of the critical phenomena, and who desire to become acquainted with the results of recent investigations in this important field of work.

As the author is able to show in his first four chapters, the equation of state affords a complete qualitative explanation of the behaviour of gases under varying conditions of temperature and pressure, including those which cause liquefaction. The whole description is admirably clear, but it may be permitted to direct special attention to three points which are not usually discussed; these are (1) the demonstration of the way in which the labile equilibrium (in which pressure and volume increase together) must collapse in such a way as to give rise to two layers of different density (p. 24); (2) the fact that in the metastable region the *p*v curves for low temperatures intersect and cross the axis of volume, corresponding with the experimental observations of Helmholtz and others that liquids may exist under considerable negative pressures without vaporisation (p. 28); and (3) the fact that the liquid in a capillary tube out of contact from air is under a pressure less than the normal vapour pressure, and is therefore metastable, and might even become labile if the capillary height were sufficiently great.

In spite of its wonderful qualitative accuracy, van der Waals's equation almost invariably breaks down when accurate quantitative tests are applied (chapters vi. to ix.). Thus, if the values of the critical constants are filled in, the expression RT/PV should have the value $8/3=2\cdot67$ for all gas; actually argon appears to give a normal value, and hydrogen the value 2'94, but a group of eighteen hydrocarbons and simple derivatives gave values ranging from 3'4 to 3'9 (p. 60), whilst polymerised liquids gave values between 4 and 5. Similar results are observed in reference to the

¹ *British Medical Journal*, 1907, ii., p. 797.

ratio of the temperature of inversion to the critical temperature; in a number of cases the ratio has the value $2\cdot98$, but this figure, though substantially constant, differs considerably from the theoretical value $27/8=3\cdot37$ (p. 68). In a third table (p. 83) are given the minimum volumes for a series of gases under extreme pressure and at low temperatures, as compared with the volumes at the critical point of each gas; the actual values:

O_2	Cl_2	CO_2	SO_2	C_2H_4	CCl_4	$C_4H_{10}O$	C_6H_6
0·278	0·282	0·269	0·243	0·243	0·260	0·255	0·258

are nearly constant at 0·26, but differ widely from the theoretical value $1/3=0\cdot33$. A fourth table (p. 71), in reference to the minima in the p/v curves, shows a precisely similar result—the four constants which are given for each of three gases agree closely together, but differ widely from those calculated from the equation of state.

In view of the failure of van der Waals to give an exact quantitative explanation of the behaviour of liquids and gases, it is natural that many attempts should have been made to correct and improve the original equation. These attempts are described in chapters xii. and xiii., but the fact that the author has found it necessary to discuss something like a dozen different equations is in itself sufficient evidence that the goal has not yet been reached.

A part of the difficulty which arises in applying equations such as that of van der Waals is due to the fact that in compounds such as water and the alcohols liquefaction is accompanied by the formation of molecular aggregates (chapter xi.); attention has therefore been directed in recent years mainly to the study of hydrocarbons and similar substances in which this tendency is at a minimum. In most cases the polymerisation is instantaneous, but the author is incorrect in supposing (p. 52) that this is always the case; thus the recent observations of Bamberger and Seligman have shown that in the case of nitrosobutane the association and dissociation (unlike those of nitrogen peroxide) proceed quite gradually. There can be little doubt, however, that he is right in attributing the anomalous densities observed by de Heen and others to the presence of impurities rather than to slow changes of molecular aggregation as postulated by Traube; on this point the evidence afforded by the author's own experiments, supplemented by the recent discussion of Verschaffelt, appears to be conclusive.

T. M. L.

AMERICAN FORAGE CROPS.

Forage Crops for Soiling, Silage, Hay and Pasture.

By Dr. Edward B. Voorhees. Pp. xiii+384. (New York: The Macmillan Company; London: Macmillan and Co., Ltd., 1907.) Price 6s. 6d. net.

THIS book is one of the Rural Science Series, edited by L. H. Bailey, and designed to give the American farmer simple but accurate instruction in scientific agriculture. Some of the series, e.g. King's "Soil," are of general interest, and are well known here; the others refer mainly to American conditions, and appeal less to English readers.

NO. 2000, VOL. 77]

Forage crops are those which are fed in the green state to animals instead of being left to ripen and produce seed: turnips, mangolds, and "temporary" grass are all examples. They play a highly important part in every scheme of general farming; indeed, their introduction into England in the seventeenth and eighteenth centuries not only revolutionised our agricultural practice, but had a considerable indirect effect on the social life of our ancestors.

The author deals with practically all the fodder crops grown in the United States, giving details of cultivation and manuring, and, in some cases, summaries of the results obtained with the crop at the various experiment stations. These summaries are perhaps the best part of the book, and will be appreciated both by the student and the farmer; we should like the author to have extended them by including short descriptions of the soil and climatic conditions. The cultivation and manuring details are treated mainly from the empirical standpoint, and here we cannot help feeling that the author has missed an opportunity. Details are of very great importance in agriculture, but they should hardly be given the chief place in a text-book like the present one. Neither the student nor the practical man can make much of them; there is an endless variety about them, and a scheme that works well on one farm may not prove suitable on another close by. What is wanted is a clear statement of the general requirements of the crop, followed by a few well-chosen detailed illustrations. In this way the student gets a real picture that will be of service to him, and the practical man is put in a position to see whether or not he can profitably grow the crop. Unfortunately, the author does not quite give us this, and if the schemes he suggests fail, the farmer is not in possession of the principles which would aid him to frame a modification suited to his land.

A perusal of the book brings out very clearly the differences between English and American practice in regard to fodder crops. The difference depends not only on climate, but also on labour supply, for in the latter respect the American farmer is worse off even than his English cousin. We learn, for instance, that one of our best root crops, the mangold, is not widely grown because of the labour required. Its place is taken by green maize, which is partly fed green and partly made into silage.

The author also deals with the different ways of using fodder crops—soiling, ensilage, and conversion into hay. Soiling was introduced into the States from Europe in the middle of the last century by Josiah Quincy, whose writings on the subject are so good that it is a pity the author makes no mention of him. The practice consists in cutting and carrying green crops to the animals, which are kept in stalls all the year round instead of going out to grass in summer. It has proved to be economical in places where land is dear and labour cheap, but is not likely to displace ensilage in America, notwithstanding the prominent place assigned to it in the book. Indeed, one hardly sees how silage could be improved upon for the American farmer; he has learnt how to make it, and as a

labour-saving device for the dairyman it has been ranked with the separator.

Certain statements will want correction in a future edition. We are told, for instance, that "the covering of land in summer prevents the temperature from rising so high as to destroy the organisms of the soil." E. J. R.

OUR BOOK SHELF.

Astronomischer Jahresbericht, Vol. viii. Die Literatur des Jahres 1906. By A. Berberich. Pp. xxxvi+671. (Berlin: Georg Reimer, 1907.) Price 21 marks.

ASTRONOMERS are fortunate in the matter of having their literature catalogued, for, in addition to the volume published by the Royal Society for the International Council, we have this very excellent annual, instituted by the late Dr. Walter F. Wislicenus, which has now reached its eighth volume.

The contents of the present issue deal with the literature of the year 1906, and it only requires a cursory glance to indicate how important it is that such a catalogue is in existence, considering the great mass of work that is being turned out every year and published, not only in all sorts of journals, but in various languages.

The very arduous task of collating and cataloguing is now annually being successfully accomplished by Dr. Berberich and his co-workers, and an important feature about the publication is its early issue.

In the present volume, which contains no less than 1961 separate brief abstracts of published papers, accompanied by a complete name-index, some minor changes have been made.

Thus all references to publications with regard to minor planets are brought together under one section number, and the tabular statement of their observation is here omitted, as it appears in full in the Berlin *Astronomical Year-book*.

The literature relating to comets is now divided between two sections, while one section includes the whole of meteor-astronomy.

In spite of the above and other alterations, the volume is not reduced in size, for longer abstracts are given of works of greater importance.

The value of this publication to astronomers cannot be overestimated, and it behoves everyone interested in this science to support it, so that the continuation of future issues may be assured.

Lehrbuch der theoretischen Elektrochemie auf thermodynamischer Grundlage. By J. J. van Laar. Pp. xii+307. (Leipzig: W. Engelmann; Amsterdam: S. L. van Looy, 1907.) Price 6 marks.

THE present volume differs greatly in character from those to which we are accustomed from the pen of Dr. van Laar. His "Thermodynamik in der Chemie" and his "Lehrbuch der mathematischen Chemie" are so formal in their nature, so mathematical in their dress, and so slightly connected with the facts of observation, that the majority of chemists can have derived little benefit from them, excellent though they may be of their kind. Here the author adopts a different method; the mathematical deductions have the clearness and conciseness which might be expected, but everywhere the experimental data are brought into the foreground, so that the electrochemist with a modest mathematical equipment may hope to gain a clear view of the thermodynamical theory of his science.

The book is divided into twelve chapters, of which the first deals with electrical units, chapters ii.-iv.

with conductivity, chapter v. with diffusion, chapters vi.-x. with electromotive force, chapter xi. with polarisation, and chapter xii. with capillary electric phenomena.

A good account of the work of Kohlrausch is given in chapter iii., and the recent researches of Walden and others on the conductivity of non-aqueous solutions, and of Lorenz on fused electrolytes, are well summarised in chapter iv. Chapter vii., on the partition equilibrium of electrolytes, contains much that is novel.

Altogether it may be said that the book is readable, original, and suggestive.

Coal. By James Tonge. Pp. vii+275. (London: Archibald Constable and Co., Ltd., 1907.) Price 6s. net.

THE author recently published an excellent little work on coal-mining for the use of students. It is disappointing, therefore, to find that in writing a book on coal for the general reader he has been less successful. The work appears to have been hastily compiled, and the proofs carelessly revised. For example, the Ruhr appears as "Rurh," Courrières as "Courrieries," Anzin as "Auzin," Resicza as "Keszicza," and Karwin as "Kirwin."

There is a useful chapter on the preparation of coal for the market; and the chapter on the botany of the Coal-measure plants is excellent, though somewhat technical for the general reader. Both these chapters are admirably illustrated. The chapters on the British and foreign coalfields, on the valuation and uses of coal, on the production of heat from coal, and on the waste of coal, contain, however, little that is not better set forth in the report of the Royal Commission on Coal Supplies, in the valuable digest of that report published by the *Colliery Guardian*, in Prof. Flux's revised edition of Jevons's work, or in other works dealing with coal. Of such works many have recently been published, for we cannot agree with the author that "it is now many years since a work on coal was presented to the public."

LETTERS TO THE EDITOR.

[The Editor does not hold himself responsible for opinions expressed by his correspondents. Neither can he undertake to return, or to correspond with the writers of, rejected manuscripts intended for this or any other part of NATURE. No notice is taken of anonymous communications.]

The Speed of Racing Animals.

IN NATURE, March 14, 1907, p. 463, there is an article giving the results obtained by Prof. Kennelly, of Harvard, from an examination of racing records. There is no harm in again directing the attention of your readers to these results. Prof. Kennelly's paper was sent July 6, 1906, to the American Academy of Arts and Sciences, and published in the Proceedings in December, 1906. It is entitled "An Approximate Law of Fatigue in the Speeds of Racing Animals." His general result is given in a question set by me in an examination in practical mathematics, January, 1907. Here is the question:—

If t seconds is the record time of a race of y yards; the law $t = cy^n$ seems to be wonderfully true for all record races of men and animals excepting men on bicycles; n is the same number in all cases. c has a special value in each case, men walking, running, skating, swimming, or rowing; horses trotting or galloping or pacing.

(1) For any particular kind of race it is found that when y is increased by 100 per cent., t is increased by 118 per cent.; find n .

(2) For men running, when $y=600$, t is 71; find c in the above formula. Express s , the average speed of each race, in terms of y .

(3) Assume that an animal has a certain amount of endurance E which is exhausted at a uniform rate during

the race, and that $E = E_0 + kt$, where E_0 and k are constants. Calling E/t the rate of fatigue f , express this in terms of s .

Assuming that an animal going at s_0 miles per hour feels no fatigue, or when $s = s_0$, $f = 0$; find f in terms of s .
(1) Contains the general result; the law is that t is proportional to $s^{1.8}$ or $s^{1.125}$. It may be stated in various other ways; for example, that the average speed in each race is inversely proportional to the eighth root of s , or a race 256 times as far is done at half the average speed.

In short races there is increase of speed at the beginning and almost always increase near the end; and it may be that there is continuous change of speed during all record races. We have only average speeds recorded, unfortunately, but still I must consider this wonderful general law to be worthy of the attention of biologists. (3) Contains a poor speculation of my own, good enough for such an examination; the answer to it is that f is equal to $E_0 c^2 (s^2 - s_0^2)$. There is nothing extraordinary in the fact that record bicycle races do not follow the law; they have been run on machines of varying quality.

The values of c found by Prof. Kennelly are, his distances y being in metres:—trotting horse, 0.0295; pacing horse, 0.0291; running horse, 0.0236; man running, 0.0588; man walking, 0.0861; man skating, 0.0385; man swimming, 0.381. Men rowing, four oars, 0.0628; two oars, 0.0768; single, 0.0824. JOHN PERRY.
Royal College of Science, S.W.

The Isothermal Layer of the Atmosphere.

The investigation of the upper air which has been in progress during recent years has revealed conditions for which it is very hard to find an explanation. When Mr. Roth first inaugurated observations on temperature and humidity by means of kites, it was hoped that the results obtained would solve many problems connected with meteorology, and this hope was strengthened when M. Teisserenc de Bort greatly extended the height to which observations could be made by his system of *ballons sondes*. It has not, however, been realised, and we seem to be as far as ever from knowing the cause and mechanism of the cyclonic storms that are so common in the oceanic parts of the temperate latitudes.

Since last June some forty balloons have been sent up in Great Britain, carrying with them a small instrument which draws automatically a pressure temperature diagram, and of these more than thirty have been recovered. The results confirm those previously obtained on the Continent, and no doubt can now remain about the existence of the curious isothermal layer in the atmosphere.

Briefly, the more important phenomena are these. As we ascend the temperature of the air decreases, at first often irregularly, with breaks and inversions, but after the first 10,000 feet (3 kilometres) have been passed with fair regularity, the usual decrease being about 3.3 F. per 1000 feet (6° C. per kilometre). This continues to a height that varies, as a rule, from 30,000 feet to 40,000 feet. Nearly always at somewhere about this height the decrease suddenly ceases. Above this point the air in most cases gets a little warmer; occasionally, however, it continues to get cooler, but at a totally different rate, and we may take the remaining air to be at one practically uniform temperature in so far as change of height is concerned. This isothermal layer, as it has been called, has been reached in England more than thirty times. On the average its height is about 35,000 feet (10.7 kilometres), but the extreme values found were 25,500 feet and 49,000 feet. As a rule, it is higher than the mean when the barometer is high, and conversely. Its mean temperature was found to be -53.6 F. (-47° C.), and the extremes were 22° F., at Ditcham Park, Hants, on July 24; -24° F., at Crinan, on July 26; -78° F., at Pyrron Hill, Oxfordshire, on September 12, 1907, and also on February 5, 1908; and -74° F., at Manchester, on November 7, 1907.

This mean value is considerably higher than the Continental one for previous years, but as thirty observations do not suffice to give a true mean, this may be accidental. Balloons have been sent up from five stations on the same day, and the temperatures over the stations have been found to differ widely. Thus on November 11 Mr.

Cave's balloon from Ditcham Park reached the isothermal layer at 36,000 feet, and its temperature was -42° F. Over Oxfordshire the height was 38,500 feet, and the temperature -58° F., while at the same time, which was a little after sunset, Mr. Petavel, at Manchester, found it at 37,000 feet, with a temperature of -74° F. This is not an isolated instance, and although the heights given may be uncertain to an extent of perhaps 5 per cent. or even more, it is very unlikely that the error in the temperature can exceed three or four degrees F. It may be accidental, but the temperature over Ditcham Park, which is near the sea, shows a tendency to exceed that over the Midlands. The balloons mostly drift to the eastward, the centre of their falling points being thirty-four miles E., 23° N., of the starting point. Doubtless several of the unfound balloons fell in the North Sea, as some have been returned from France and Holland.

Various suggestions have been made to account for these results. There is, of course, no difficulty about the general decrease of temperature with height, but why should the fall suddenly cease when from one-third to one-fourth of the mass of the atmosphere remains above? In general, the transition point is perfectly sharp and distinct. It is said that the vertical circulation ceases at this point, and no doubt the statement is true, but why should it cease? There is a further difficulty. The absence of vertical motion implies a condition of equilibrium, but how can there be equilibrium with such large horizontal differences of temperature? At the height of 40,000 feet the pressure is small, and therefore trifling changes of pressure produce large changes of volume and temperature; hence large changes of temperature might be expected if we could assume some horizontal force, comparable with gravity, and capable of producing changes of pressure without producing vertical motion. The horizontal acceleration due to centrifugal force in a curvilinear path and that produced on a moving body by the earth's rotation are too small; also it seems to me that these forces, being due to motion of the air, must produce some vertical circulation, which apparently does not exist.

The problem is one of the most interesting presented at the present time to physical science, and it is not unlikely that its solution might clear up many other puzzling questions. W. H. DINES.

The Inheritance of "Acquired" Characters.

MR. ARCHDAL REID in his previous letter said (p. 293) "innate characters arise inevitably as the child develops, whereas some acquisitions are more or less rare, but this is only because the stimulus of nutriment is inevitably received, whereas the stimulus of a particular use or injury may not be received. If, however, the latter be received, the acquisition arises just as inevitably as the innate characters." This latter statement seemed to me particularly incorrect for the reasons which I stated; and now Mr. Reid practically admits (p. 342) that it cannot be accepted as it stands, in face of the fact that the inherent tendencies of the germs of different human beings vary so much, and must therefore react variously to the stimulus of use.

My chief objection, however, to Mr. Reid's view was that contained in his statement that "in man the main difference between the infant and the adult is due to use, acquisitions made by the latter during development." His whole case in the discussion hinges upon this statement, by which he seeks to establish a purely arbitrary distinction between the causes leading to the development of the human being anterior to birth and subsequent to birth—the stimulus in the one case, he says, being nutriment, and in the other use. As an illustration of his position, Mr. Reid said (p. 293)—"Thus, if the limb of an infant be paralysed it grows comparatively little, and the muscles atrophy." But this is by no means to be taken as a simple illustration of the fact that the muscles will not develop except under the stimulus of use, because the illustration ignores the fact that what happens in the way of retarded growth of the paralysed limb, together with actual atrophy of muscles, is, quite apart from the lack of use, largely due to a severance of the normal relations between the limb and the great nerve centres, and the

consequent cutting off of the "trophic influence" exercised by the latter.

Again, it is a part of Mr. Reid's doctrine, as he tells us, to regard the power of walking and the power of speaking as use acquisitions, while I, on the contrary, hold that the effects of use-exercise seem to be predominant in these cases simply because the efforts made to walk or to talk take place *pari passu* with the development of the nerve centres concerned with such accomplishments.

As I have said elsewhere ("The Brain as an Organ of Mind," p. 562), "the helpless condition of the infant monkey and of the human infant at birth are similarly to be ascribed, in great part, to the immature condition of their great nerve centres." Many of the movements which they slowly learn to perform are doubtless rendered possible by, and acquired coincidentally with, the actual development of those nerve cells and fibres in the spinal cord and medulla which are instrumental in the execution of such movements. Thus, when we say that the young child "learns" to perform these movements, it should be understood that this word is here applicable only in a very qualified sense. . . . But for the existence of this organic *nisus* (in the form of an inherited tendency to develop in certain modes and directions) the human infant could never so readily as it does acquire the power of executing the excessively complex movements which are concerned in walking, or in articulate speech."

In illustration of these views I have cited cases in which walking was an untaught act in a child at the end of her second year, as there had been no previous trials and failures; and also a case (*loc. cit.*, p. 607) in which a child who had been absolutely dumb up to the end of his fifth year suddenly began to speak under an emotional stimulus. Another very similar modern case, as well as two cases recorded by ancient writers, of untaught acts of speech are also cited in my work on "Aphasia and other Speech Defects" (1898, pp. 6-8).

No explanation of such facts seems possible except on the supposition that speech has now become a truly automatic act for human beings. Such untaught acts of speech would not, however, be possible unless cerebral development had been taking place in a normal manner, and unless the auditory sense and intelligence were unaffected.

These are some of the reasons why I dissent from Mr. Reid's view that "in man the main difference between the infant and the adult is due to use acquisitions made by the latter during development," and why I say that post-natal growth and development are essentially due to the same inherent causes as pre-natal growth, notwithstanding the fact that use-exercise comes in as a powerful aid during the former period.

As to the extraordinary power of memorising shown by Chinese and Mohammedan children to which I referred Mr. Reid, in accordance with his views he would deny that any influence is to be ascribed to the practice in memorising carried on by ancestors of the children through very many previous generations; and in that case he must suppose that English children, as a class, should be capable of showing similar feats of memory, even though their ancestors had not been accustomed to any extraordinary exercise of their memorial faculty.

For the rest, that Mr. Reid's views do not suffice to close the controversy as to the inheritance of "acquired" characters may be easily seen by any of your readers who will refer to Herbert Spencer's "Principles of Biology," revised edition, 1895, App. C, pp. 692-695, and to his "Facts and Comments," 1902, pp. 92-96. I might even venture to refer your reviewer, "A. D. D.," to a consideration of the facts and arguments set forth in these works.

H. CHARLTON BASTIAN.

The Athenæum, London, February 15.

I SAID that acquisitions are just as "innate" as "inborn" characters. Dr. Bastian read this—I am sure I cannot imagine why—as implying a denial of the occurrence of variations. I repudiated his interpretation, and this he now terms an admission! The muscles of a limb atrophy equally when they are rendered useless by joint disease as when there is "severance between the limb and the great nerve centres."

The Lamarckian doctrine is founded on two unproved assumptions:—(1) that use causes development in all characters, and (2) that parental acquisitions tend to affect the germ-cells in such a way that the traits which arise in the parent under the stimulus of use are reproduced by offspring under the stimulus of nutriment—that is, when the parent acquires one thing the child is supposed to "inherit" something inherently different and much less useful. The second assumption was formerly universal, but has now been abandoned by the vast majority of biologists. Most of us know, or think we know, how great an obstacle it was to the attainment of truth and how much deeper and clearer has become our knowledge of nature since its abandonment. We suppose it was held merely because men tend to accept current beliefs without bestowing on them that critical and sceptical thought which is one of the essentials of real scientific work.

The first assumption is still very generally made, and I think for the same reason. Unsupported by an iota of evidence and obscuring the fact that a principal feature of the evolution of the higher animals has been the evolution of a power of developing under the stimulus of use, it is as great an obstacle to the recognition of truth as the other. Many human structures are plainly incapable of developing under the stimulus of use, for example, hair, teeth, external ears, and memory. These are wholly "inborn" (*i.e.* developed under the stimulus of nutriment). The evidence seems massive that many lower animals, for example, the Coleoptera and Lepidoptera, owe little or no part of their physical and mental development to use. Hence their lack of individual adaptability. But higher in the animal scale, memory (the power of profiting by mental experience, of growing mentally under the stimulus of use) becomes apparent, and increases until it bestows on man all that makes him preeminently the educable, rational, and adaptable being. *Pari passu* with this increase of the power of growing mentally under the stimulus of use has occurred an equally great evolution of the power of growing physically under the same stimulus. In my view, then, (1) while memory and the homologous power of growing physically are "inborn," all that arises from the exercise of them is "acquired"; (2) not all human characters are capable of developing under the stimulus of use, but only a majority of them; and (3) in the case of the latter all, or nearly all, that separates the infant from the adult is due to the stimulus of use.

Either Dr. Bastian is putting the cart before the horse or I am. I believe, for example, that use develops body and mind until we are able to walk, talk, and so forth. He believes, apparently, that we would develop physically and mentally into mature men, and would walk and talk and get a knowledge of Latin and so on even if we never used body and mind. The blessed words "trophic influences" and "organic *nisus*" afford him complete satisfaction. Surely his assumption is made "in the face of multitudinous difficulties." To him man's adaptability, the vastness of his memory, the great development in him of the instincts of sport, curiosity, and imitativeness, which impel him to make precisely the physical and mental acquisitions which bring him into harmony with his own individual environment, tell no tale. He is in a position as unhappy as those investigators who, before defining what they mean by "inheritable," spend years of labour in ascertaining exactly what is "inherited."

Mr. Cunningham says, "innate characters are those which develop without any stimulus except what Dr. Reid calls the stimulus of nutrition," or nutriment as I prefer to term it. But is not nutriment "external"? A scar cannot develop under this stimulus, and I imagine it would puzzle Mr. Cunningham to explain in what sense nutriment is more innate than injury or use. Obviously all characters develop under the influence of some external stimulus, and the distinctions between characters are due, not to greater or lesser innateness, but to the kinds of stimuli that cause them to appear. Acquisitions arise for precisely the same reason that all inborn characters arise—because evolution has created the power of responding in quite definite ways to quite definite external stimuli; clearly, then, they are innate in precisely the same sense as inborn characters.

February 21.

G. ARCHDALL REID.

Mr. CUNNINGHAM says (p. 367) that my article was as dogmatic as it could possibly be. It was meant to be. It was meant to stir up those who continue to use the old terms "acquired" and "innate" without really bothering much about their signification. It has achieved its object admirably.

He also says that I assert that there "is no sense in the distinction between acquired characters and innate ones with regard to inheritance" [which I did not say], "that all characters are both acquired and innate" [which I did]; he continues:—"This in the accepted meaning of the words is simply untrue." Well, of course it is. My point was that the accepted meaning of the terms was vague, that it had led to confusion, and that it ought to be dropped.

Mr. Cunningham does not follow me. I am willing to admit that that may be my fault. I fully recognise, as he does, that the characters of organisms may be divided into two big categories, which have for a long time been called "acquired" and "innate." But I hold that the difference between these two classes of characters is very inadequately expressed by the terms "acquired" and "innate," and that a much better, though, of course, provisional, classification of characters is into (a) those which owe their existence to the interaction between some innate factor and the stimulus (for want of a better term) of nutrition, and (b) those which owe their existence to the interaction between some innate factor and the stimulus of use or injury.

The view that all characters are acquired during ontogeny as the result of a definite stimulus acting on an innate factor was expressed by Weldon (*Biometrika*, vol. 1, p. 367), who has also described (*loc. cit.*) how he succeeded in preventing the appearance of the amnion in the hen's egg by withholding the necessary stimulus.

A full answer to Mr. Cunningham's letter is quite out of the question, because it would involve a discussion on all the meanings of the terms "innate" and "acquired" and a history of their use, which could not be compressed within the limits of a single number of NATURE. But reference must be made to one of the things "innate," as opposed to acquired, certainly does not mean. Whatever it means, it does not mean what it literally means. It does not mean the kind of character one is born with. Before it was known that all organisms develop from a single cell! it may have meant that, but now that we know that they do, we regard classifications of characters into those which appear before the act which separates intra-uterine from extra-uterine, and those which appear after it, as interesting from a historical point of view only. Yet in this year 1908 we actually read in a letter to NATURE (I am not quoting from memory) that a Negro "is brown (not black) when he is born; that is an innate character." The facts are true, of course, but not relevant. The fact that a negro is brown when he happens to be born does not matter. The fact we have to face is that the ovum which gave rise to Booker T. Washington was probably not browner than that which gave rise to George. The statement that the colour of the former is innate does not in the least help us to understand the causes to which the difference between the colours of the two men is due.

A. D. D.

[FURTHER space cannot be devoted to this correspondence.—ED.]

The Possibility of Life in Mars.

THE perseverance with which Prof. Lowell has prosecuted his investigation of the surface markings of Mars compels admiration; the evidence he has brought forward for the objective reality of much of the detail he has shown in his sketches serves to convince many reluctant minds; but the interpretation he has put upon these markings, in terms of phenomena associated with life as we know it on our own planet, requires stronger evidence than he has yet brought forward in view of the considerations that follow.

The blue-green coloration he attributes to vegetation; its change to chocolate-brown to the fading of verdure with the change in the season. If we grant that the conditions on Mars have been possibly such as to allow of the develop-

ment of living organisms from inorganic matter, is it likely that the course of evolution has been so exactly similar to that on the earth that a chlorophyll-bearing organism has resulted? Like conditions produce like results—granted; but when one considers the quasi-fortuitous nature of the conditions determining the characters of those organisms that survive in the process of evolution, the remoteness of the probability that the development of the power of forming chlorophyll should happen twice, in two independent evolutionary systems, seems overwhelming.

Again, Prof. Lowell attributes the markings which he considers irrigation systems to intelligent beings. It is possible that that high degree of adaptability to environment, which we call intelligence, might have evolved independently on two planets, but it seems in a very high degree improbable.

Similarly, other points in his scheme of interpretation may be conceivable, but highly improbable. But the probability of the whole is the continued product of all the independent probabilities! The evidence, then, in favour of Prof. Lowell's views will require to be of a much more overwhelming character to claim the assent of those who appreciate their extreme improbability.

Opposition to the views of Prof. Lowell has generally been based on difficulties regarding the physical condition of Mars. It is the object of this letter to emphasise the far greater improbabilities involved in the biological aspect.

Prof. Lowell attributes the reluctance of many to accept his position to the emotions of men. I venture to think that emotions are in his favour; it is the human desire for an anthropomorphic interpretation of nature—in this case perhaps one should rather say a geomorphic interpretation—that has prompted his views, and but for which they would receive small consideration.

C. O. BARTRUM.

12 Heath Mansions, N.W., February 17.

IN Dr. William Lockyer's review of Dr. Russell Wallace's book on the habitability of Mars he refers to Dr. Johnstone Stoney's contention that aqueous vapour cannot exist on a planet of that size because the velocity of the molecules would be too great for its attraction to retain them. I do not know what temperature was assumed in the calculation, but a dozen miles above the surface of the planet the temperature of its atmosphere must approach absolute zero—a condition of things in which even hydrogen would not have the necessary velocity to escape.

The question is an important one for those who are interested in the history of the earth, for, whether we choose the nebular or planetesimal view of its origin, there must have been a time when the attraction it exercised on the outer portion of its atmosphere was far less than at present, and if Dr. Johnstone Stoney were right there would be some difficulty in understanding how any water-vapour remained.

J. W. EVANS.

Imperial Institute, S.W., February 15.

The Stresses in Masonry Dams.

PROF. PEARSON'S letter in NATURE of February 20 requires little in the way of reply from me, since my essential point is now admitted, viz. that the stresses xx and zz are practically the same in a slab, whether it be free or form part of a complete dam. I should, however, like to point out to Prof. Pearson, *re* his comparison between a parabola and an equivalent sine curve, that at 5° the ordinate is only one-twelfth the maximum ordinate, so that an error of 30 per cent. in this ordinate is one of but $2\frac{1}{2}$ per cent. on the maximum, which would be, accordingly, absolutely negligible in practical engineering. As regards the remainder of his letter, engineers have the support of many eminent elasticians in their refusal to accept his and St. Venant's dictum that the maximum stretch is the proper criterion of the safety of a structure. In any case, the true criterion is a question for the engineer and the physicist, and not for the mathematician. The most recent experiments, I may add, negative Prof. Pearson's views on this head.

H. M. MARTIN.

83 St. James's Road, Croydon.

THREE ANIMAL BIOGRAPHIES.¹

MR. LONG is always interesting and original, and he is especially so in the daintily illustrated little volume standing first on our list, of which individuality in animals seems to be the keynote. Premising that no species breeds true in all its individuals, the author urges that analogous differences in temper, disposition, and mind reveal themselves to those who take the trouble to observe closely. All who make pets of cats, dogs, horses, and other domesticated animals are fully convinced of the existence in them of individual traits and idiosyncrasies; and the apparent absence of these in wild species seems due merely to the want of careful and minute observation of their habits. That such individualities do exist the author demonstrates, for example, in the case of the American lynx, which, although normally a cowardly and slinking creature, will on occasion follow the trail of a hunter with as mischievous intent as a panther. As usual, Mr. Long discusses members of widely different groups, and in the present volume we have delightful peeps into the life-histories of the black bear, the wolf, the wild goose, the trout, and other denizens of the forest and the stream. Where all is good, it is difficult to make a selection; but we have personally found special interest in the chapter on the bear. Describing the actions of a bear when ant-hunting, the author tells us that "he just knocks the top off the hill, stirs up the nest, and lies down quietly, placing his fore-paws where the ants are thickest. At first he makes no effort to pick up the hurrying insects, workers and fighters, which swarm out of their tunnels. . . . 'Moorveen' waits till they crawl over the big black object that rests over the nest, and then he begins to lick his paws more and more greedily as he tastes the acid things. . . . So he gets all he wants, cleanly from his own paws, instead of filling his mouth with dust and chaff, as he must do if he attempted to catch them in any other way." Many other passages in this attractive volume bear equally eloquent testimony to the closeness with which its author has observed the habits of the creatures he loves so well and describes so graphically.

In the volume standing second on our list, Mr. Graham Renshaw brings to a close his long series of articles on mammals, interesting either from their rarity or from peculiarities in their structure or habits. The four-and-twenty species here discussed include a very varied selection, ranging from the musk-ox and the European bison to the Pacific walrus, the Tasmanian devil, and the platypus. As in the case of the earlier essays, the author deals specially with the historical aspect of his subject, and furnishes his readers with a large amount of detail connected with specimens exhibited in menageries and museums. Several

of the illustrations are taken from specimens in the British Museum, and among these special attention may be directed to the one of the Congo buffalo, as an example of what may be accomplished in the way of photographing animals as they stand in the cases of the exhibition galleries. We may, however, venture to take exception to the photograph of a very tame-looking park bull being made to do duty for the extinct aurochs; and we should also like to know why the author, in defiance of Herberstein's evidence, states that the latter animal was mainly white. The



Bearded Titmouse and Young. From "Home-Life of some Marsh-Birds."

¹ (1) "Whose Home is the Wilderness; some Studies of Wild Animal Life." By W. J. Long. Pp. xii+230; illustrated. (Boston, U.S.A., and London: Ginn and Co., 1907.) Price 35s. net.

(2) "Final Natural History Essays." By Graham Renshaw. Pp. xii+222; illustrated. (London and Manchester: Sherratt and Hughes, 1907.) Price 6s. net.

(3) "Home-Life of some Marsh-Birds." By Emma L. Turner and P. H. Bahr. Pp. 62; 32 plates. (London: Witherby and Co., 1907.) Price 2s. 6d.

assertion that all typical sheep have a lacrymal gland (p. 114) seems also to be contrary to fact, while the statement (p. 105) that two Greenland musk-oxen exhibited in 1900 were the first examples of their race known to science is contradicted on the following page by a reference to calves received in England in 1899.

The author has evidently devoted a large amount of time to working out the history of the various species, and he has certainly succeeded in producing a very attractive volume.

One of the objections to the employment of photography as a means of illustrating natural history books is that very frequently the animals are taken in postures which do not display their leading characteristics, and thus render the pictures more or less completely useless for the purpose of specific identification. The same thing applies in the matter of characteristic attitudes and the nature of the habitat; and, in the case of birds, to the form of the nest and the appearance and growth stages of its occupants. To remedy these shortcomings in the case of the feathered denizens of British marshes has been the main object of the authors of the charming little volume standing third in our list. They have set themselves the task of portraying marsh-birds in positions and attitudes which will render the pictures of real service to the scientific ornithologist; and we venture to think that the verdict of their readers will be a pronouncement of unqualified success in this respect. As a specially good example of their work we may cite Miss Turner's photograph of a bearded titmouse, showing the black face-marks of the cock from which the species takes its name. This would not print satisfactorily in the pages of NATURE, but we are able to give another illustration showing the bird feeding its young. The book does not, however, depend entirely on its illustrations, and even in such a hackneyed subject as the life-history of British birds, the reader will find much of interest in the brightly written biographies which accompany the plates.

R. L.

STUDIES IN NATIONAL DEGENERATION.¹

THE several aspects of study which the statistics deal with in this memoir are chiefly parental and fraternal heredity, the fertility of tuberculous stocks, and the distribution of pulmonary tuberculosis in tubercular families. Prof. Pearson's observations are admittedly, from a numerical standpoint, wholly insufficient, but if his deductions are thereby rendered inconclusive, he has pointed the way and laid the foundation for further study of an all-important subject.

Prof. Pearson discusses only pulmonary tuberculosis, that is, phthisis, or, as it is popularly termed, consumption; yet even with this limitation it is uncomfortable reading that about 10 per cent. of the inhabitants of the British Isles are affected by pulmonary tuberculosis. Unfortunately, other organs besides the lungs become the seat of tuberculosis, and their disorganisation is attended by as serious results as when the lungs alone are considered. It may be that tuberculosis of the lung is, from the point of possible national deterioration, not the most deadly form of the ailment. Tubercular diseases of the bones of the joints, of the lymphatic system, and of several of the organs other than the lungs, prevail to an extent little appreciated as being of an equally deadly nature, with the more evident lesions in the lungs. They all indicate a diathesis, and give rise to types of infirmities well known to medical men. These evils of tuberculosis, therefore, are much more widely spread than pulmonary tuberculosis or consumption would give us to understand, and being less manifest to the public scrutiny are more insidious and more apt to be neglected in the reckoning of tuberculous disease generally.

That heredity plays an important part in tuberculous disease is, in Prof. Pearson's opinion, un-

doubted. Recent beliefs point rather to infection as being the major element in rendering the disease so prevalent, and it is noteworthy that Prof. Pearson inclines to the older belief of heredity. He finds that tubercular lung trouble is chiefly prevalent amongst those who inherit a predisposition, that is, a phthisical or consumptive diathesis. It is impossible, however, owing to insufficient data, to assume that the tendency to any disease is inherited in the same sense as are physical and mental characteristics, but did inheritance not explain the matter it is difficult to understand how anyone escapes the disease, seeing that, in urban districts especially, the tubercle germ is so prevalent that "few individuals who lead a moderately active life can escape an almost daily risk of infection."

Such being the case, the tubercle germ can thrive best in the suitable soil to be met with in lung tissues which are prepared by hereditary predisposition, or, in some cases, by what may be termed accidentally acquired predisposition in the lung tissues themselves, by previous local lesions. That the predisposition to the lung becoming the seat of tuberculous disease is to be statistically ranged alongside well-established inherited characteristics, such as physical and mental traits are known to be, can only be proved by obtaining complete histories of multitudes of families and family stocks. This, however, is at present a long way off being established, and until this gap is filled any deductions we make at present can only be speculative for the most part.

The period of life during which tuberculosis is most likely to show itself in the lungs is between the ages of twenty and thirty. The mean age of onset in men is set down at the twenty-ninth year, and in women at the twenty-fifth year. The actual danger zone cannot, however, he said to be passed until the fortieth year, or perhaps the forty-third year, is passed.

The observation that there is but an insignificant difference between the time of onset of the disease when some member of the household is the subject of tuberculosis and when no member is thus afflicted is rather against the infection theory pure and simple; for with the constant possibility of infection in the immediate environment, phthisis should, according to infection beliefs, appear at an earlier age than statistics seem to show.

After discussing the part played by parental and fraternal heredity, Prof. Pearson concludes that the tuberculous diathesis is inherited in the same way and with the same intensity as the physical characters are inherited in man.

Concerning the fertility of tuberculous stocks, Prof. Pearson shows that the pathological conditions do not tend to reduce fertility, but, on the other hand, that such stocks appear to be quite as fertile, and in all probability are more fertile, than normal stocks of the same class in the community at large. The fact, however, that tuberculosis is a disease of youth and early middle life distinctly lowers the marriage rate and limits the child-bearing period of such stocks, and thus reduces the total number of offspring born to tuberculous people; there can be no doubt that by the inbreeding of purely tuberculous persons the stock would become in time extinct.

The question of order of birth, that is, whether the child belongs to the early or late portion of a given tuberculous family, is of considerable interest. Are the elder or the younger members of the family the more liable to develop tuberculosis and to possess a tuberculous diathesis? The children of old people, of, say, a man over sixty and a woman of forty-seven, are popularly believed to be handicapped in the struggle for life owing to inherited physical defects. There is no

¹ Drapers' Company Research Memoirs, II. A First Study of the Statistics of Pulmonary Tuberculosis. By Prof. Karl Pearson, F.R.S. Pp. 26. (London: Dulau and Co., 1907.) Price 3s.

real evidence that this is the case, as many instances for and against the contention can be given. Whether the child of elderly parents is healthy or not depends not so much upon the age as upon the health of the parents; for a man with, say, Bright's disease—the prevalent ailment of men over sixty—will certainly not beget a healthy offspring. It would seem, however, from a general study of constitutional defects which are inherited, that the elder members of the family are more liable to suffer than the younger. In the case of tuberculous families, as well as with stocks giving no parental tuberculous history, the elder offspring, especially the first and second, appear subject to tuberculosis at a very much higher rate than the younger members.

This observation is of especial interest when the modern notion of the limitation of families is considered. There are few "younger members" to the small and limited families of to-day. The two or three children born to a couple of parents would represent the elder branches only of the "old-fashioned family" of a dozen of some fifty years ago. We have just seen that Prof. Pearson declares that the first and second child are endowed with all forms of pathological heritage, and if there are only two children in the family, the limited family of the present day is producing a community of persons highly endowed with a pathological heritage, uncorrected in its national deteriorating effect had there been later children of the marriage—that is, children less likely to have inherited in a marked manner the pathological tissues or diathesis of their parents.

If we are to believe the above statement, and there is no evidence against its being logically acceptable, we are brought face to face with the question of the benefit or otherwise of the law of primogeniture which so largely obtains all the world over. From a racial standpoint the first and second children, as we have seen above, are the worst members of the family to beget a stock free from pathological taints; yet it is to the eldest son that the preservation of the family, and its possessions, its titles, or its wealth, is entrusted. To push this point to its seemingly logical conclusion, it would come about that the eldest son of one family marrying the eldest daughter of another family would in time lead to an effete progeny and the extinction of the power of rearing children. As a prophylactic agency in this scheme of pathologic inheritance, it would appear essential, to correct the deteriorating effects of intermarriage between elder members of different families, that the eldest child of one family should marry with a younger child of another family.

The limitation of families to one or two children is therefore a highly detrimental factor in national eugenics, for not only is there no allowance for what appears to be the inevitable waste attaching to child life, but the progeny, if thus produced only during the early years of married life, is calculated to add in time more affected individuals to the community, seeing it is the first-born children especially that inherit family traits of physique and diathesis.

The predominance of race depends on the preservation of the mentally and physically fitter stocks. In the struggle for existence amongst primitive peoples this is "naturally" provided for by the exigencies of life, but amongst a highly civilised race, such as our own, the fitter stocks appear likely to be weakened "by the lessened intensity of the intraracial struggle and the differential limitation of the family."

It is scarcely necessary to state that Prof. Pearson has handled this subject, as he handles all the problems he deals with, in a manner at once logical, unbiased and rigidly scientific. We are willing to

accept Prof. Pearson's conclusions from the basis he starts from; but until the basis is widened a hundred fold it would be rash to formulate definite and incontrovertible deductions in regard to the effects of the inheritance of any pathologic diathesis for any given ailment.

SIR RICHARD STRACHEY, G.C.S.I., F.R.S.

ON Wednesday, February 12, there passed away, at the advanced age of upwards of ninety years, a distinguished son of a distinguished Anglo-Indian family, Lieutenant-General Sir Richard Strachey, R.E., G.C.S.I., LL.D., F.R.S. To give any adequate impression of a career which extended from 1836, when Richard Strachey left Addiscombe to join the corps of engineers of the East India Company, to 1907, when he retired from the chairmanship of the East Indian Railway Company, would be in any case a difficult task, and when, as in this case, a life of nearly ninety-one years is more remarkable for the versatile activity of the spirit that animated it than for its length the task becomes insuperable.

He was elected a Fellow of the Royal Society in 1854 for scientific work in botany, geology and physical geography, carried out while he was stationed at Nani Tal, in the Kumaon Himalayas, whither he was transferred from engineering work in connection with the Ganges canal on account of repeated attacks of fever. In 1867, the year in which he was appointed Knight Grand Commander of the Star of India, a Royal medal was conferred upon him for his investigations in physical and botanical geography and meteorology. "Two of the most recent of these," quoting from the award, "are recorded in his report, published in 1888, on the barometrical disturbances and sounds produced by the eruption of Krakatoa and in his paper in the *Phil. Trans.* of 1893, entitled 'Harmonic Analysis of Hourly Observations of the Temperature and Pressure at British Observatories.' These, while important in themselves, are but the last of a long series of valuable memoirs. He was the first to treat scientifically of the physical and botanical geography, geology, and meteorology of the Western Himalaya and Tibet. He also first observed the occurrence of a regular series of fossiliferous rocks, from the Silurian upwards to the north of the great snowy axis of the Himalaya. His numerous papers on these subjects, dating from the year 1847, are published in the Journals of the Royal Asiatic, Geological, and Royal Geographical Societies' Proceedings, and in the reports of the British Association."

In 1873 he had returned home and was appointed a member of the meteorological committee of the Royal Society which controlled the Meteorological Office, established in 1867; he was a member of Sir William Stirling Maxwell's committee which revised the constitution of the governing body of the office, and was a member of the council which replaced the committee in 1876. After a further period of absence in India on special duty, he resumed his place on the council; in 1883, upon the death of Prof. H. J. S. Smith, he was appointed chairman and filled the office for twenty-two years. He was president of the Royal Geographical Society from 1887 to 1889. He received the Symons medal of the Royal Meteorological Society in 1906.

His scientific activity, although closely interwoven with the rest of his work, was only a part of his life. He won distinction as an engineer in the conduct of irrigation works and as a soldier in the Sutlej campaign. His greatest claim to remembrance is based upon his achievements as head of the Indian Public

Works Department, and the various successful organisations which he initiated in that capacity. It is not too much to say that he and his younger brother John, who died about two months ago, were for many years the principal figures in the administration of the Indian Empire. "The Finances and the Public Works of India," the title of a book which they published, is not inapt as a description of the position of the two brothers under Lord Mayo. Between 1871, when Richard Strachey returned to England, and 1879, when he finally retired from India to resume his place on the Indian Council, he held various appointments in connection with the India Office or in India, including the chairmanship of the Madras Famine Commission of 1878. In 1889 he became chairman of the East Indian Railway Company, and added to his reputation for business capacity by the successful administration of that undertaking. As a financier he represented India at the Monetary Conference at Brussels in 1892, and as a geographer he was one of the delegates of Great Britain at the Prime Meridian Conference at Washington in 1884.

My personal recollection of Sir Richard Strachey goes back to 1880, when I was engaged upon some work for the Meteorological Council. He was keenly interested in questions about the distribution of water vapour in the atmosphere. The vertical distribution was the subject of a paper in the Proceedings of the Royal Society in 1862. My recollection is that he had a good deal to do with disposing of an idea that I have seen attributed to Herschel, that in reckoning the pressure of the atmosphere, water vapour did not count. I write vaguely on this point, because to reconstitute the physical conceptions upon which meteorology was based before the 'sixties is to place oneself in the age when heat was still regarded as material, and the conservation of energy was an imperfectly formulated idea.

As president of the Royal Geographical Society he endeavoured to promote the teaching of geographical science, and he came to Cambridge to give lectures on geography, a missionary effort undertaken to show that geography was not really beneath the attention of a university. The distribution of vapour pressure in the atmosphere as determined by his own observations up to 18,000 feet in the Himalaya was again discussed. At that time the university recognised his contributions to the advancement of science by conferring the LL.D. degree. He returned to the subject of aqueous vapour in the atmosphere again in the determination of the heights of clouds by photographic observations at Kew, a preliminary report on the measurements was contributed to the Proceedings of the Royal Society in 1891, and there still exists a great store of unworked material.

From 1897 onwards I was closely associated with Strachey in the management of the Meteorological Office, and I speak without hesitation for his colleagues, Galton, Wharton, Buchan, Darwin, Field, and Scott, in saying that association with him was not the least among the privileges which attached to membership of the council. His clear insight into the questions at issue, his perfect lucidity in thought and expression, the logical marshalling of facts in the official documents which he wrote as chairman, will always be memorable. He had not much patience with people who were imperfectly acquainted with the facts of a case under discussion, and he never cared to argue with them, but difference of opinion on lines of policy, even when ill expressed, never ruffled his serenity in the conduct of business. From time to time while he was chairman, the office was subject to criticism, which was not always fair, but he never

complained. He was always content to attribute the criticism to want of knowledge of the facts. He would not even let us indulge in the semi-official pastime of abusing the Treasury. Their responsibility had to take account of an aspect of the matter with which we were not cognisant, namely, where the money was to come from, and we must be content to accept a judgment that had to reckon with public opinion in its executive form as well as with scientific aspirations. Speaking for myself, as one accustomed for many years to the details of business of college meetings and university syndicates, Strachey's methods of transacting corporate business were a revelation.

As regards his later contributions to the science of meteorology, some words of explanation are necessary. He had watched, and indeed had been largely instrumental in providing the facilities for, its study both in India and in this country, on the new lines of the comparison of results for different parts of the country or of the world. He was conscious that the new science required a new method, that the method of the physical laboratory, which aims at elucidating a physical process by experiments specially directed thereto, was inapplicable to the case of the free atmosphere. Those who are critical of the vast accumulation of meteorological data which is going on are apt to be unaware of the fact that data have to be collected in advance, and that, to this day, nearly every attempt to deal with a meteorological problem of any importance is baffled by the want of data; they are equally unmindful of another noteworthy fact, namely, that in meteorology comparison is of the essence of the science. The meteorologist is absolutely dependent upon other people's observations; his own are only useful in so far as they are comparable with those of others. Thus the time, trouble, and money spent upon organisation are not the expressions of limited scientific ambition, but a primary condition for securing indispensable facilities. Strachey's scientific judgment was extraordinarily acute. He was quite prepared to carry on investigation to a speedy issue when circumstances permitted, as in the investigation of the Krakatoa eruption already alluded to, which led to the recognition of a drift from east to west in the upper air of the equatorial regions as a primary meteorological datum. In dynamical meteorology he was convinced that the most promising mode of attack was not to look for a direct dynamical explanation of the striking features, the eccentricities of the day's weather, which are the almost fortuitous result of many causes combined in various phases, but to seek for the relations between regular sequences and their causes underlying the apparently arbitrary variations. For this reason the methods of harmonic analysis specially attracted him, and he was disposed to regard anything less general than five-day means as unmanageable. He never completed the work on harmonic analysis that he had in hand. He attached particular importance to the third Fourier component of diurnal variation, because the length of the day in these latitudes oscillates between one-third and two-thirds of the twenty-four hours. A few years ago he took up again the investigation of the question, and he has left a considerable amount of unfinished material.

He was not to be driven from a position of modest optimism about such matters, and always explained that for a new science the progress made in the last fifty years is quite as great as could fairly be expected.

But he was no friend of the unnecessary compilation of data or of the unlimited extension of mean values. Almost the last contribution that he gave me was a

computation of the number of years necessary to reach a mean value for temperature within the limits of the probable error of the mean value for a single year, based upon some tables published in 1902 for the extrapolation of mean values. He was always more concerned to present meteorological data in a form amenable to computation than to increase their volume or detail. When the weekly weather report was initiated in 1884, he provided formulæ for computing the true daily mean from the maximum and minimum temperatures for the day, and for computing the amount of effective and ineffective warmth as referred to a base temperature of 42° F., which are still in use. He once astonished me by pleading for graphical representation as being easier to read than columns of figures, for he could extract the meaning of a page of figures with a facility that made the discussion of results with him an indispensable part of any piece of work that was in hand. Yet he was more than eighty years of age when we had to transact this kind of business together. He never lost his appreciation of new methods which were sound, or of new projects which were promising. Throughout his administration of the office he held to a high scientific ideal while maintaining the efficiency of such daily work as was required for public use and for international cooperation. His scientific horizon was a wide one. With Stokes and Balfour Stewart, he was largely instrumental in providing means for the organised study of the sun, which had been commenced in this country and in India by Sir Norman Lockyer, in order to trace the primary causes of those great meteorological fluctuations which exhibit themselves in alternations of drought and plenty in India, a study which, pursued for many years at the Solar Physics Observatory at South Kensington and at Kodaikanal, in India, has recently taken its place among the greater international organisations. As head of the Public Works Department in India, he transferred meteorological work in that dependency from a provincial to an Imperial basis under Blanford and Eliot, and laid the foundation for the admirable organisation of which the Government of India and its scientific staff now enjoy the advantage. At the same time, he initiated the forestry department and the application of botanical science to the service of the public in that department.

Probably no single person had clearer views of the future that lies before meteorological work as a matter of practical influence upon everyday life, or was more fully conscious of the long years of observation, organisation and study that are necessary to secure the advantages which will ultimately more than reward the long years of patient inquiry.

Above the mantelshelf of the unpretentious room over a piano shop in Victoria Street, which for more than forty years has been the chief centre of meteorological work in this country, there is a clear-cut profile of an old but by no means aged man, giving an unmistakable presentment of intellectual strength altogether undisturbed by side-issues and petty difficulties. Such indeed was Strachey. Beneath the portrait over his characteristic signature are the last words of a letter written about an office balance sheet that I thought more than usually depressing. "On the whole there is nothing to complain of." For meteorologists this is, at times, a hard saying; but to me at least it is entirely characteristic of the spirit with which he insisted upon meeting the difficulties that confronted us. "A heart that is established and will not shrink," a keen appreciation of the practical services which science can render in the present and in the future, a simple determination to regard

the whole, to make the most of the means at his disposal without grumbling—these are the abiding recollections of the ten years of our association at the close of a long life devoted, with untiring energy, to the service of his country.

W. N. SHAW.

NOTES.

DR. C. CHREE, F.R.S., has been elected president of the Physical Society of London for the ensuing year.

THE annual congress organised by the Prehistoric Society of France will be held this year at Chambéry from August 24 to August 30.

M. BOUQUET DE LA GRVE has been elected president of the Bureau des Longitudes for 1908, M. Poincaré vice-president, and M. Bigourdan secretary.

PROF. W. J. SOLLAS, F.R.S., was elected president of the Geological Society of London at the anniversary meeting on February 21.

THE director of the Royal Meteorological Observatory at Agram, Hungary, informs us that the founder and former director, Prof. Ivan Stožir, died on February 12 after a short illness.

DR. H. F. OSBORN, one of the vice-presidents of the American Museum of Natural History and curator of vertebrate palæontology, has been elected president of the museum in succession to the late Mr. Morris K. Jesup.

It is reported from Berlin that Mr. Andrew Carnegie has given half a million marks (25,000*l.*) to the Robert Koch fund for the campaign against tuberculosis. The amount collected so far for carrying out research work in connection with the disease amounts to 800,000 marks (40,000*l.*).

AN exhibition and sale of farm and garden produce, organised by the Women's Agricultural and Horticultural International Union, will be held in the gardens of the Royal Botanic Society, Regent's Park, N.W., on Wednesday, July 15. All communications should be addressed to the secretary, Miss Eileen Johnson, c/o Mrs. T. Chamberlain, 5 Priory Mansions, Drayton Gardens, S.W.

THE American Society of Naturalists has made arrangements to celebrate the one hundredth anniversary of Charles Darwin, in cooperation with the American Association for the Advancement of Science, on the occasion of their meetings in Baltimore in 1908. The Society of Naturalists, we learn from *Science*, will be represented on the committee of arrangements by the president, the secretary, and several members.

ON Thursday next, March 5, Sir John Rhys will begin a course of two lectures at the Royal Institution on "Early British History and Epigraphy," and on March 7 Prof. J. J. Thomson will commence a course of six lectures on "Electric Discharges through Gases." The Friday evening discourse on March 6 will be delivered by Prof. John Milne on "Recent Earthquakes," and on March 13 by Chevalier G. Marconi on "Transatlantic Wireless Telegraphy."

REPLYING to a question in the House of Commons on Tuesday, Mr. Churchill said:—"It is impossible to obtain accurate statistics regarding the mortality from sleeping sickness in Uganda, but, in a recent despatch, the Governor has estimated the number of deaths at 200,000 during the past seven years. Every effort is being made by the

Government to combat the disease by scientific investigation under the direction of the Royal Society, by local administrative measures, and by international cooperation with the other Powers whose possessions in Africa are similarly afflicted."

THE council of the Royal Society of Arts has awarded the gold medal offered by the society, under the Shaw trust for industrial hygiene, to Prof. W. Galloway, "in recognition of his valuable researches into the action of coal dust in colliery explosions, the outcome of which researches has been the provision of means by which the risk of such accidents is materially diminished, and a consequent great saving of human life effected."

IN connection with the International Congress on Tuberculosis, which will be held in Washington on September 21 to October 12, a prize of 300l. is offered for the best treatise that may be submitted to the congress on the relation of atmospheric air to tuberculosis. The prize is offered by the Smithsonian Institution out of the Hodgkins fund. The treatises may be written in English, French, German, Spanish, or Italian. They will be examined, and the prize awarded, by a committee appointed by the secretary of the Smithsonian Institution in conjunction with the officers of the International Congress on Tuberculosis.

WE learn from the Berlin correspondent of the *Times* that on February 20 the Reichstag passed the second reading of the Bill for the regulation of wireless telegraphy, in accordance with the decisions of the International Congress in Berlin in 1906, and conferring a monopoly of wireless telegraphy upon the Government. The German Government desires to maintain an attitude of neutrality towards all systems of wireless telegraphy, and in particular to secure intercommunication on the part of ships and land stations without regard to the system employed. Germany has accordingly declined to bind herself to any one system, upon the ground that the efficiency of the system adopted is of far greater importance than its technical character. The special committee of the Reichstag to which the Bill was referred was informed that messages by the Marconi system would be accepted by German ships and stations if the company conformed to the obligation to exchange communications with other systems.

LAST year some opposition was shown in the American Congress to the usual vote of funds to the Biological Survey, certain members of the committee on agriculture suggesting that this branch of the agricultural department was more ornamental than useful. Accordingly, a paragraph was inserted in the Appropriation Bill directing the Secretary of Agriculture to investigate the work of the survey, and particularly to inquire into the value of the work done by the Government ornithologists. A report of this investigation has now been issued, and a whole column of the New York *Evening Post* is occupied by a summary of the services which Secretary Wilson finds that the Biological Survey has rendered to American farmers and horticulturists. Not only has this bureau issued valuable bulletins and other publications, but it has prepared the way for important legislation for protecting useful birds and for preventing the importation of such as would be injurious. A typical example is the success of the bureau in preventing the importation of the loblouse, the introduction of which was advocated through misapprehension in the apple-growing districts of the Pacific Coast and the North-West, where it might have done enormous damage.

Two striking examples of the best style of modern taxidermic art are displayed in the central hall of the natural history branch of the British Museum in the shape of a male and female Californian sea-elephant from Guadalupe Island. The specimens are the gift of the Hon. Walter Rothschild, and probably represent some of the last survivors of their species. They have been mounted by Rowland Ward, of Piccadilly, in whose establishment may now be seen a walrus set up for the Edinburgh Museum, which is likewise practically a revelation in the matter of mounting as compared with the bloated mummies by which the species has hitherto been represented in our exhibition galleries.

A DISCOVERY of exceptional interest is announced in vol. vi., part iii., of *Annotations Zoologicae Japonenses* (December, 1907), namely, the occurrence of a fresh-water medusa, referred to the genus *Limnocoedium*, in the Yang-tsi-kiang about 1000 nautical miles from its mouth. *Limnocoedium*, it will be remembered, has hitherto been known solely by *L. soeverbyi*, discovered in 1880 in the Victoria water-lily tanks at the London Botanical Gardens, and subsequently observed in similar tanks at Lyons, but never yet found in its native home. According to its describer, Dr. Asajiro Oka, the new Chinese species, for which the name *L. kawaii* is proposed, differs from *L. soeverbyi* in certain points, which are, however, insufficient to admit of its generic separation, although rendering necessary some slight modifications in the definition of the genus. The home of the typical species is generally supposed to be Amazonia (not the West Indies, as Dr. Oka states), and it is hence possible that the genus may have a distribution analogous to that of tapirs, alligators, or spoonbill-sturgeons. It may, however, be found that *Limnocoedium* is widely spread in the rivers and lakes of Asia. The Yang-tsi species was discovered in April last by Captain Kawai, of the steambot service, near Ichang, in the province of Hupi, ten specimens having been obtained. The muddy condition of the waters of the river accounts for the medusa having previously escaped observation.

MR. JOHN BROGDEN, of 28 Colville Square, London, has sent us a copy of a catalogue of natural history specimens, in which is included biological material of almost all kinds other than skins of vertebrates. Among the specimens catalogued we notice a series of models of whales and dolphins, on a scale of 1 inch to the foot.

LANCELETS and lampreys form the subject of a paper by Mr. H. W. Fowler in the issue of the Proceedings of the Academy of Natural Sciences of Philadelphia for December, 1907. Of lampreys, the author describes, under the name of *Oceanomyzon wilsoni*, a new genus and species on the evidence of a specimen a foot in length from the Atlantic. It is regarded as connecting the true lampreys, *Petromyzon*, with the deep-water *Bathymyzon*; it may occur at some depth.

THE first part of *Sitzungsberichte Natur. Verein der preuss. Rheinlande und Westfalens* for 1907 contains an account of the scientific results of a journey recently undertaken by Dr. Borgett to East Africa and the Nyanza. Although the expedition was mainly undertaken for the purpose of studying the plankton (of which certain new forms are described), the author furnishes some interesting information with regard to the big-game fauna of the Athi Plains and Nairobi, where he is of opinion that the protective laws enforced by the British Government are working satisfactorily. Giraffe, kudu, and eland were seen

in numbers in several places, while hartebeest, gnu, water-buck, Thomson's and Grant's gazelles, and, above all, bonte-quagga, occurred in enormous herds, and rhinoceroses and hippopotamuses were by no means uncommon. The extinction, or decimation, of the fauna is, according to the author, not likely to occur for many a long day. Such testimony from an impartial and unprejudiced observer is as satisfactory as it is valuable.

FOR some years a difference of opinion has prevailed among palæontologists with regard to the systematic position of the group of Upper Tertiary mammals typified by the European genus *Chalicotherium*. In these mammals, it may be mentioned, the cheek-teeth are of the general type of the Perissodactyla, whereas the feet are of an ungulate character, the latter feature having long led to the belief that these mammals were members of the Edentate order. Since the date of the association of the teeth with the foot-bones (when the ungulate affinities of the group could no longer be doubted), Mr. Lydekker has persistently maintained that there is no justification for separating the chalicotherioids from the Perissodactyla, whereas American palæontologists have with equal confidence asserted that they should form a subordinal (or ordinal) group by themselves. In an article contributed to the *American Naturalist* for December, 1907, Mr. O. A. Peterson, from the evidence of specimens referable to the genus *Moropus*, concludes "that *Moropus* is, excepting its ungulate feet, essentially a perissodactyle in structure. That the laterally compressed and cleft condition of the terminal phalanges is quite distinct in some of the early Perissodactyla, and that by adaptation . . . the unguals of *Moropus* were specially modified, and should not . . . be regarded as of ordinal importance."

M. GASTON BONNIER records in the *Comptes rendus* of the Paris Academy of Sciences (vol. cxlv., No. 27) some interesting observations on what he terms the *raisonnement collectif* of bees. In one of his experiments he placed in his garden several lumps of sugar; these were visited by bees, which, however, were unable to bite off its particles on account of the weakness of their mandibles. The bees were marked by the experimenter, and were seen to fly off to their hive; in one to two hours they returned with other workers, but this time they flew, not from the hive, but from a fountain of water. On settling on the sugar they were seen to pump water from their crops on to the sugar, and then suck up the syrup so formed, finally flying back to the hive. Other observations convinced M. Bonnier that individual bees were able to communicate news of their discoveries of fresh sources of honey to the colony, and he has reason to believe that the number of workers summoned is always proportional to the supply of honey that has been found.

THE *Bio-Chemical Journal* for January (iii., Nos. 1 and 2) contains several interesting papers, notably one by Prof. Moore and Dr. Roaf on the equilibrium between the cell and its environment in regard to soluble constituents, with special reference to the osmotic equilibrium of the red-blood corpuscles, in which the conclusion is formulated that the difference in composition of the electrolytes within and without the cell, and the physiological effects of perfusion or irrigation of cells by media defective or excessive in certain electrolytes normally present in the cell receive a simple explanation, on the basis of the formation of adsorptates or chemical combinations between cell protein (or protoplasm) and other constituents.

THERE are two essential factors with others required for the success of a nature-study course, the one that the course should be seasonal, the other that the instructor should manifest a continuous and keen interest in his subject. The first point has been effectively brought out in a pamphlet by Prof. J. A. Thomson, issued from Aberdeen University, wherein he indicates suitable lines of study for various courses. The notes refer to physical, botanical, and zoological studies. A careful perusal of the pamphlet cannot fail to supply teachers with suggestions and stimulate interest.

THE January number of *Tropical Life* contains information with reference to a rubber exhibition that is already arranged to be held at the Royal Horticultural Hall in September this year, and an International Rubber Exhibition that it is proposed to hold in London a year or two hence. In the same journal useful information with regard to methods of cultivating and curing tobacco in Porto Rico is contributed by Mr. D. W. May, and the value of manures for cacao plantations forms the subject of one of a series of articles dealing with the cultivation of cacao.

A CONTRIBUTION by Mr. F. Ramaley on the silva of Colorado, dealing with the woody plants of Boulder County, is published in vol. v., No. 1, of the University of Colorado Studies. The flora provides an interesting study in altitudinal distribution, since the elevation of the county varies from about 5000 feet to 10,000 feet at the foot of the main range, while the highest peak exceeds 14,000 feet. Grass lands rise up to 6000 feet, when open forest of rock pine, *Pinus scopulorum*, and Douglas spruce, *Pseudotsuga mucronata*, is found. A zone of lodge-pole pine, *Pinus murrayana*, mixed with rock pine and limber pine, *Pinus flexilis*, reaches to 10,000 feet, above which the Engelmann spruce is dominant. Higher again in the Alpine zone, the only woody plants are dwarf willows.

A NUMBER of the *Philippine Journal of Science* (vol. ii., No. 5), devoted to the descriptions of commercial Philippine woods, has been prepared by Mr. F. W. Foxworthy. It contains a general discussion of their structure and properties, a key for their identification, and notes on the species. The key is elucidated by means of a series of fifty-five photographs representing transverse sections. Of timbers well known on the European market, only teak and ebony are found; the former is very scarce, and the ebony is chiefly derived from *Maba busifolia*, with less valuable timber from *Diospyros pilosantha* and other species. "Narra" is a first-class timber yielded by *Pterocarpus indicus* and allied species, therefore related to Indian "padouk"; also the tree known in India as "poon," *Calophyllum inophyllum*, provides a timber that is employed for construction and furniture. Other valuable species are *Homalium lusoniense*, *Illipe betis*, *Pithecolobium acle*, species of Lagerstroemia, *Intsia* and *Vitex*, and *Pahudia rhomboidea*.

A PAMPHLET on the geology of the Roberts-Victor diamond mine has been published by Mr. J. P. Johnson (Johannesburg). This mine, which is situated in the Boshof district, Orange River Colony, presents many points of geological interest, and the author's observations lead him to believe that kimberlite, the rock in which the diamonds occur, is not an igneous rock, but a purely fragmental one, simulating in parts an igneous structure owing to changes induced by hot water or steam, and that it is to these factors that the extreme alteration of the mineral constituents of both the peridotite and pyroxenite boulders and of the matrix in which they lie is due.

A DETAILED description of the geology and mineral resources of Lawlers, Sir Samuel, and Darlot (East Murchison goldfield), Mount Ida (North Coolgardie goldfield), and a portion of the Mount Margaret goldfield is given by Mr. C. G. Gibson in Bulletin No. 28 of the Geological Survey of Western Australia. The report, which covers seventy-three pages, and is accompanied by three large folding maps and five mining plans, shows that rocks of the district comprise granites and greenstones, the payable gold quartz veins occurring in the latter. The granites are seen almost everywhere to be intrusive into the greenstones. The quartz veins appear to be of later origin than the granite, and in most cases they occur at no great distance from its junction with the basic rocks. The district under review had returned, up to the end of 1906, 581,104.61 ounces of gold.

THE RECORDS of the Geological Survey of India (vol. xxxvi., part ii.) contain the report on the mineral production of India during 1906 compiled by Mr. T. H. Holland, F.R.S. Compared with the previous year, there was an increase of 10.9 per cent. in the value of the total production. The production included 581,545 ounces of gold, 9,783,250 tons of coal, 140,553,122 gallons of petroleum, 495,730 tons of manganese ore, and smaller quantities of salt, saltpetre, mica, ruby, sapphire, jadedstone, graphite, iron ore, tin ore, chromite, diamonds, magnesite, and amber. In the same issue Mr. E. W. Vredenburg describes the ammonites of the Bagh beds, and there are several interesting brief miscellaneous notes. Amongst these there is a description of the occurrence of wavellite, which has apparently not been previously recorded from India, in the Singhbhum district, Bengal.

DR. GUSTAV BRAUN, of the Geographische Institut, University of Greifswald, announces that he is anxious to collect information as to "Bodenbewegungen," which he defines as movements taking place on restricted areas of the earth's surface as the result of gravitation (*Jahresbericht der geographischen Gesell. zu Greifswald*, 1908). He does not propose to include mountain-folding, though this might attract Herr E. Reyer and Dr. Ampferer, to name no others; but he seeks cooperation from those who have the opportunity of observing slow or sudden movements of the soil, landslides and rock-falls, flows of peat, and all kindred superficial phenomena. The results of human operations are to be included. Dr. Braun issues forms to those who can assist him, on which exact details of each case studied can be entered, and he is even willing to collect extracts from newspapers. Surely he cannot be acquainted with the reckless treatment of natural phenomena by the popular American and English Press. Yet his circulars will probably bring to his notice certain carefully studied examples of rock-creep, bog-sliding, and so forth, which will afford material for comparison with those examined by himself.

IN part I. of *Aus dem Archiv der deutschen Seewarte* for 1907, Mr. A. Paulus discusses the duration of the passages of German sailing vessels in 1893-1904. This laborious investigation, which should be of practical utility as well as interesting from a general point of view, deals with the three large oceans (the outward and homeward voyages being separately discussed), and shows the average duration and the times of the longest and shortest passages in the period mentioned. The tables also give the duration of the shortest passages from about 1870, including the results obtained from a somewhat similar discussion by Dr. Schott prior to 1893, and observations from other sources. From the latter it is seen that a fair number

of the shortest voyages has occurred in the more recent period, and this result, we think, may be reasonably ascribed to the dissemination of useful information in American, English, and German charts. We note that Mr. Paulus is able to say that there are only a few German sailing vessels which do not keep a meteorological log for the Seewart.

THE hydrographical researches carried on in connection with the international fishery investigations continue to lead to the issue of a number of useful monographs and reports. Amongst those now before us are the current issues of the *Bulletin des Résultats acquis pendant les Croisières périodique*, which has recently been enlarged in scope, with great advantage, to include observations taken during three-monthly periods, as well as those taken on the regular quarterly cruises. The number of charts and sections illustrating the results arrived at has also been increased. In *Publications de Circonstance*, No. 40, issued by the International Council, Mr. Johan Gehrke discusses the mean velocity of the Atlantic currents running north of Scotland and through the English Channel. These two currents constitute the sources of supply of Atlantic water to the North Sea. Mr. Gehrke calculates that the whole water volume that yearly passes round the north of Scotland (within certain defined limits) is about 61,000 cubic kilometres, and has a mean salinity of 35.15 ‰, whilst the annual water supply to the North Sea through Dover Straits is 2036 cubic kilometres, and its mean salinity 35.07 ‰. In *Publications de Circonstance*, No. 38, Mr. Martin Knudsen points out that in certain areas the determination of the salinity of the surface water may be of very great service to the navigator in helping him to fix the position of his vessel at sea.

A NOTE on certain Maori carved burial-chests, by Mr. T. F. Cheeseman, is published in the *Transactions of the New Zealand Institute*, vol. xxxix. Although it had been recorded that maonoa trees, *Dacrydium colensoi*, were reserved by the Maoris for making coffins, there is little or no information regarding such coffins in which the bones were placed. The burial-chests recently discovered, and now stored in the Auckland Museum, are carved into the rough similitude of a human figure, except two of a different shape. So far as evidence is forthcoming, they may be two hundred years old.

TO the January number of the *Journal of the Gypsy Lore Society* Mr. A. B. Sinclair contributes an article on the Oriental Gypsies. His view that there are no Indian Gypsies, that the recent find of Oriental books at Turfan, with other evidence, shows that the civilisation and phonetics we have been wont to consider special to India flourished at one time north of the Himalaya, and that therefore there is no need to seek the origin of the Romani speech in India, is startling, and not likely to be accepted without further proof than that furnished in the present article. The revived society, which has its headquarters at 6 Hope Place, Liverpool, deserves the support of all who are interested in this remarkable race.

TWO papers, one by Mr. Edgar Buckingham in the *Bulletin of the Bureau of Standards* (U.S.A.), iii., 2, and another by Mr. J. D. Hamilton Dickson in the *Philosophical Magazine* for January, show that there is still material for discussion in the already much discussed "Joule-Kelvin" experiments on the determination of absolute temperature by the flow of gases through a porous plug. Mr. Buckingham introduces the subject with a short discussion of the fundamental equation,

which, as he points out, affords a direct comparison between the constant pressure scale of any gas and the absolute scale, but which cannot be applied directly to the constant volume temperatures without knowing the isothermal equation of the gas. He discusses the various empirical assumed formulae for the "cooling effect," and the conclusions deducible from them. The relations of actual gas scales to the thermodynamical scale are set forth, but the author considers that the time is approaching when a mere reference of temperatures to "the gas scale" will be insufficient. Mr. Dickson's paper deals with the inversion temperature of the Joule-Kelvin effect both for small and for finite differences of pressure, with special reference to Olszewski's experiments.

THE *Physikalische Zeitschrift* for February 1 contains a description, by Dr. C. W. Lutz, of the filament electrometer invented by himself and Dr. M. Edelmann, jun. The filament consists of a Wollaston platinum wire of about 0.001 mm. diameter suspended vertically between two narrow vertical plates, one of which can be put into electrical connection with the wire, while the other may be connected either to earth or to some source at constant potential. The repulsion of the filament from the former plate when both are charged is observed through a small microscope magnifying eighty times, and by suitably adjusting the tension of the filament the range of the instrument may be made to extend from 2 volts to 1000 volts. It is very compact, and its electrical capacity is less than 10 cm.

MR. C. W. BURROWS, of the United States Bureau of Standards, after extensive experiments on the various methods in use for demagnetising iron in magnetic testing, comes to the conclusion that the following is the best method of procedure:—the current should be reversed about twice a second, and diminished at such a rate that the decrease of induction is as nearly as possible the same each second, the process to last about ninety seconds. In obtaining the magnetisation curve of the specimen, the magnetisation current should be reversed about the same number of times, and near the end of the series two throws of the ballistic galvanometer about twenty-five reversals apart should be observed. If they agree, they may be taken as representing the normal induction. The next observation may be made by this method without its being necessary to again demagnetise the specimen (*Bulletin* for January).

A NEW and cheap edition (price 5s. net) of Mr. Benjamin Kidd's "Principles of Western Civilisation" has just been published by Messrs. Macmillan and Co., Ltd. The original work was reviewed at length in *NATURE* of April 24, 1902 (vol. lxx., Supp., p. vi). In a long introduction, which appears for the first time in the new edition, Mr. Kidd replies to points raised by his critics, and refers to some differences between the evolution of the individual and of a social organism. Mr. Kidd has been appointed to deliver the Herbert Spencer lecture for 1908 before the University of Oxford in May or June next. Three lectures have already been given, namely, in 1905 by Mr. Frederic Harrison, in 1906 by Mr. Auberon Herbert, and in 1907 by Mr. Francis Galton, F.R.S.

OUR ASTRONOMICAL COLUMN.

SATURN'S RINGS.—The January number of the *Astronomical Journal* (vol. xxvii., No. 1, p. 35) contains an article by Prof. Barnard in which he describes and discusses his recent observations of Saturn's rings with the 40-inch refractor of the Lick Observatory. On July 2,

1907, Prof. Barnard found that, although no direct sunlight was falling on its earthward side, the entire surface of the ring was distinctly visible. On each ansa were two prominent condensations symmetrically placed with respect to the ball. On October 4—when the earth again passed back to the shadow side of the ring—and for some days after, the ring was perfectly linear, and the condensations, which, if they were real masses on the ring system, should then have been best seen, had disappeared.

From his observations Prof. Barnard concludes that it is not merely the illuminated edge of the system which we see when the earth is on the shadow side, but the feebly luminous surface of the ring itself viewed very obliquely. The luminosity is caused by the transmittance, by repeated reflections from the particles comprising the ring, of sunlight. Adopting this interpretation, the condensations are produced by the outer brighter part of the inner ring, the higher illumination of which, as seen ordinarily by directly reflected light, or, as during these observations, by light which had by successive reflections passed through the ring, is probably due to the denser agglomeration of its particles.

THE OBJECTIVE PRISM IN SOLAR SPECTROSCOPY.—A device by which double equatorial refractors, as employed for stellar photography, may be adapted to serve as objective-prism spectroscopes in solar observations, is described by M. E. Schaer in No. 4233 of the *Astronomische Nachrichten* (p. 137, February 15). The solar rays, passing through the first objective, are, by two reflections by plane mirrors, projected along the axis of the second telescope. Before reaching the second tube the reflected image is, however, intercepted by a slit plate, so that only the narrow beam which passes through the slit traverses the tube to the object glass. On passing through the latter the light falls upon the objective prism, which is silvered on the posterior face, so that after two dispersions and one reflection it passes again through the object-glass and down the tube. The solar spectrum thus produced may be viewed with an ocular, or an arrangement for photographing it may be substituted. By the interposition of a second slit in front of the photographic plate and mechanical movements this instrument may be used as a photospectroheliograph.

UNIFORMLY DISTRIBUTED DARK SPOTS ON JUPITER.—In an article which appears in the January number of the *Bulletin de la Société astronomique de France*, Mr. Scriven Bolton describes a number of Jovian phenomena observed by him in recent years, and pays particular attention to a series of dark markings which are symmetrically distributed along the northern edge of the south equatorial and the southern edge of the north equatorial bands. As these spots occur in the same longitudes on each band and partake of a common motion, Mr. Bolton concludes that they have an objective existence. Generally, the alternate spots on the opposite bands are joined by festoons of dark material which cross the equatorial regions obliquely at angles of 45°. The spots on the southern band present the more marked uniformity, there being twenty-four of them at regular intervals throughout the whole length of this band. Drawings made on June 15, 1899, November 4, 1903, and February 23, 1907, respectively, are reproduced to illustrate Mr. Bolton's description.

DOUBLE-STAR OBSERVATIONS.—Finding that the published magnitudes of the components of double stars are generally only given approximately, Dr. Joel Stebbins, director of the Urbana Observatory, Illinois, U.S.A., decided to make a number of systematic photometric observations of them, and he now publishes the results in the *Bulletin of the University of Illinois* (vol. iv., No. 25, 1907). After describing the instruments employed and the system of observation, Dr. Stebbins gives a catalogue of the 107 double stars which he observed, and discusses the probable errors and the differences from the Harvard observations of the same objects. On comparing the results with other available observations, no evidence of variability could, with certainty, be detected, and in the case of θ^1 Orionis—the Trapezium stars—it appears certain that no change greater than 0.08 magnitude has taken place since the Harvard observations were made in 1878.

PLANETARY PHOTOGRAPHY.

THE recording on photographic plates of the canals of Mars is as significant from a technical point of view as it has proved of widespread interest in its result; for the method which alone rendered success possible had to be developed, previous celestial photographic processes being inadequate to the task. At the request of the editor of NATURE, I propose to give some account of the method pursued, and the more gladly in that it is evident from attempts to follow it that its principles are as yet as much a *terra incognita* as have for so long remained the canals themselves. The process is the outcome of four years' study by Mr. Lampland, who, to a knowledge of the end desired, acquired from visual work on the planet, added experimental research on the means to attain it. Of the difficulty of the subject the best testimony are the words Schiaparelli wrote the writer on receiving in 1905 the first prints from the plates:—"I would never have believed the thing could be done."

The fundamental distinction between planetary photography and photography of the stars is that that with the former definition, not illumination, is the primary point. To imprint upon the plate such delicate tracery as the canals of Mars requires a definition so far beyond celestial photography in general as to constitute a class of work by itself. For one is here concerned with quantities of the second order of minuteness.

Definition, therefore, had to be studied. The chief disturber of the image is the atmosphere. A knowledge of how this conditions the seeing is, then, the first requisite to success. Living as we do under a gaseous ocean in constant turmoil, no image from beyond it stays perfect for long, soon being either distorted or displaced by the shifting refraction of differently dense layers of air. The effect we notice every day in the twinkling of the stars. To educate the eye to sift the fleeting impressions it receives is thus the first step to becoming an observer of Mars. Distrust of its own revelations because of their short-livedness is one chief cause of failure to see the canals. More, not less, is a like handicap true of the camera; for the eye is some thousands¹ of times as sensitive as the films we can employ. So that at first it would seem hopeless to attempt to part the good moments of definition from the bad, and thus to prevent the superposition of a poor or shifted image upon a clear-cut one, to the resulting disheartenment of a general bur.

To catch the planet's fugitive expressions of itself, speed of exposure becomes imperative; and that as many such as possible might be seized, a special camera had to be devised, something which should realise the demon-machine of Clerk-Maxwell for images in place of molecules, to let the good ones through and stop the bad. The mechanical part of this Mr. Lampland contrived by a plate-holder fitted with a lateral ratchet motion worked by a bulb, and capable of being pushed up and down after each line of images had been secured. At the opposition of 1905 this camera was worked without guiding, as the exposure time seemed not to necessitate it, but for that of 1907 Mr. Lampland suggested the use of, and fitted on, the 6-inch as a finder. In spite of the very short exposure possible, the sifting thus introduced turned out an improvement.

The next difficulty in definition lies with the glass. The best of its name, no achromatic lens is achromatic, and the departure from perfection is practically

Flagstaff objective diaphragmed down to 12 inches, and with the aperture weakened by a screen that takes off at least three-fourths of the light. The eye sees on Mars' canals in less than the twentieth of a second which it takes the plate two seconds to register with. The full aperture of the 24-inch glass

imperceptible to the eye, such is not the case with the sensitised film; for the rays of different colours form their images in different focal planes. Of these, the eye selects what it will attend to, while the camera cannot, and so, on the plate, if an image made by one colour be in focus, it must perforce be surrounded by others that are not. A reflector, of course, avoids this blur of superposition, since all the rays are brought to one focus, but, on the other hand, it introduces more serious errors of spherical aberration; for not only does any want of figuring or of sag in the mirror, but any disturbance in the air produces three times the distortion it does in the glass. It is thus problematic whether a reflector can ever be used for such fine work, though we intend to give it a trial with a 3-feet mirror.

To secure approximate monochromatism, and thus a more clear-cut image, a screen or filter of coloured glass, or of a coloured solution between glass, had to be used to cut off certain of the rays. This device is the same that was used visually by Schiaparelli, and that has been used at Flagstaff in like research, though it has not been

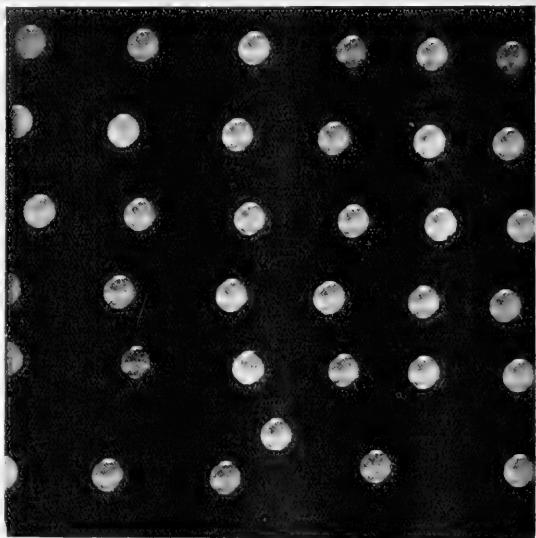

Photographs of Mars; Ganges region. Taken by Prof. Percival Lowell at Flagstaff, July 28, 1907.

found there so effective as a neutral-tinted glass, because, as mentioned above, the eye does its own sifting for the rays it elects to observe. Photographically it was first employed by Ritchey in his photographs of the moon, and here its value is inestimable. The general method of making the screens is to determine first the colour-curve of the objective, that is, the curve in which the abscissæ represent the wave-lengths of the rays of differing refrangibility and the ordinates their focal lengths. From this curve it becomes possible to select what rays shall be allowed to pass to secure a sufficient approximation to monochromatism, and the screen is then coloured to attain the result. In the construction of such screens Mr. R. J. Wallace is preeminent, and by him in this manner were made those for the Flagstaff glass.

The next crux entered with the plates. In consequence of the greater relative deviation in focal length suffered by the blue rays, which are the ones most actinic, and those to which the ordinary plates are sensitised, such plates cannot be used for interplanetary photography. To get enough light with them to approach instantaneity the

blue rays would have to be made use of, and they would irretrievably blur the image. Plates sensitised to other parts of the spectrum must be employed, and as it has not been possible to make such adapted only to the yellow and orange rays, a coloured screen must be used in connection with them. Only when more restricted emulsions shall have been produced will it become feasible to dispense with the sifter.

The plates most nearly giving us what we wanted proved to be Cramer's isochromatic instantaneous plates. They are neither instantaneous nor isochromatic, but their two negatives nevertheless combine to the best affirmative it is now possible to obtain; for beyond their mountain mass of reaction in the violet and blue, to speak figuratively of their curve of sensitiveness, they have a hillock in the yellow with sides of great abruptness. By Mr. Lampland, who carefully experimented with every kind of plate, these were found, and for the above reason, to yield the best results in the way of speed with definition. Their chief drawback consists in their not being so finely grained as one could wish.

This brings us to another difficulty that had to be encountered. In the sensitising of plates speed is inevitably associated with coarseness of grain, and *vice versa*. Finely grained emulsions are necessarily slow. To avoid the Scylla of over-exposure is to fall into the Charybdis of under-definition. As speed must be got at all hazards, the images of Mars are not so fine in texture as those securable of earthly scenes, as, for example, by lantern-slide plates. This is to be remembered in scanning the images. Anything beyond a slight magnification of the original negatives results in perceptible, though not always perceived, blurring of the details due to the showing of the grain. Photographic experts will thoroughly appreciate this, and trace the linearity of the canals clearly through its partial disguise.

After all other points have been attended to, there still remains the question of aperture; for the smaller the aperture the sharper the definition for the same sized magnification, the gain from the point of view of the air-waves vastly exceeding the loss due to a larger spurious disc. Thus with an image magnified to four hundred diameters, a 12-inch gives ninety-nine times out of a hundred more clear-cut detail than a 24-inch. This, which is so decided a gain in visual work, is partially offset in photographic work by the necessary increase in exposure time, and the consequent greater chance of mixing poor moments with the good. As the exposure time decreases inversely as the square of the radius of the glass, while the improved definition increases inversely as that radius, Mr. Lampland, in 1907, used only the full aperture of the 24-inch. In this decision I quite concur from the results at the last opposition, merely adding the gloss that with the larger aperture one is more certain of a good image; with the smaller, one will score an even greater success on exceptional occasions. This, of course, is to be taken within limits.

By the general method I have outlined Mr. Lampland secured the first photographs of the canals at the opposition of Mars in 1905. Some fifty of the canals show upon his plates. This success was entirely due to his exhaustive study and attention to all the factors I have formulated. During the time between 1905 and 1907 Mr. Lampland continued his research, and in June, 1907, took his first plates at the opposition just passed. The images showed a marked advance. In 1905 he had registered the Nilokera double (12° apart). In June, 1907, the Gihon (5° apart) stood duplicate in his photographs, while the Euphrates (4° apart) pretty certainly showed in the same manner, though from principles of conservatism I was not willing to commit myself to its announcement. At the same time plates were taken by me showing in like manner a great number of single canals, and the double Gihon and almost unquestionably the double Euphrates appear. For the same opposition an expedition was undertaken by the Lowell Observatory to the Andes under the charge of Prof. Todd, Mr. E. C. Slipper, of the Lowell Observatory, being detailed upon it armed with a duplicate of our apparatus, and thoroughly coached beforehand by Mr. Lampland in its employ. Mr. Slipper, by whom all the work of the expedition on Mars, both photographic and

definitory, was done, secured plates in July at Alianza, Chile. The place had been chosen primarily because of its lying in the solar eclipse belt, Prof. Todd being desirous of observing the annular eclipse there, but it proved, although but 4000 feet above sea-level, probably the best locality that could have been selected. By a skill and assiduity deserving of the highest praise, Mr. Slipper obtained some 10,000 images of the planet in the course of a couple of weeks. Owing to the remarkable steadiness of the air and the high altitude of the planet, his plates show a wonderful amount of detail. The doubling of the Gihon and of the Euphrates previously registered at Flagstaff were also exhibited on them, besides canals and oases in profusion. As an instance of the latter I may mention the distinct showing of the two little oases in the Trivium. His drawings were no less remarkable. As an example, the double Ganges, which for two oppositions now the writer has observed stronger on its right or western side than on its eastern, appears with this same differentiation in Mr. Slipper's picturing, although he had no previous acquaintance of the fact. Having discovered that he has an eye for planetary detail, he is to continue such study in the future.

The future promises even more than the past has fulfilled. Several improvements have been effected, or are in contemplation, which were not put into operation at the opposition of 1907. One of them is a new screen devised by the writer. Though both conceived and constructed before the opposition, it was only tested this last summer, but enough to show an improvement in definition from its use. Its basic principle was the integration of the greatest amount of illumination with the least focal difference of wave-length. To explain the idea, suppose that the light reaching the plate for each ray be weighted according to its proximity for focal length to a given focal distance by an inverse function of such departure, the function becoming negative after a certain discrepancy because the inclusion of the ray then does more harm than good. Suppose this light summed for all the rays between certain limits. The most effective screen will be that for which the integral is a maximum. The point up to which the rays should be cut off, as indicated by an examination of the colour curve of the 24-inch glass, seemed to lie at $\lambda=5000$, and for this, accordingly, I asked Mr. Wallace to construct a special screen. The result, though for some reason not so effective practically with bathed plates as was theoretically to be expected, proved successful with Cramer's isochromatic instantaneous plates, owing to the insensitiveness of the plate for the red and ultra-red rays, and to the fact that $\lambda=5000$ marked a minimum in its action followed by a rise.¹

Other devices which should improve the process are also to be practised, and these, with the increased presentation of the planet's disc, should result in another decided advance in photographic presentment; for the planet will in 1909 be more advantageously placed for Flagstaff on three counts:—

- (1) A larger disc.
- (2) A greater altitude.
- (3) A more developed condition of the canals due to the advance in the Martian season.

In spite of the interest which the taking of such photographs has caused, it must be remembered that after all the eye remains our most potent instrument of research. So thoroughly was this realised at Flagstaff that the photographs were originally undertaken simply with a view to their educational value. Inasmuch as these photographs in good air are superior to untrained eye observations in a poor one, they serve to dispel directly a modicum of doubt; though they cannot at present equal what the trained eye can see under similar conditions. But indirectly they do more; for they corroborate completely, so far as they go, visual observations which have been so extensively denied, and establish, therefore, a very strong presumption that those visual detections are true also beyond what the photographic plate has power to portray. In this connection it is interesting to note that more than one astronomer who has seen the canals from a middle ground of definition neither good nor bad has

¹ For a more detailed account of the device, see the Lowell Observatory Bulletin, No. 31.

adduced the photographs as he interprets their features as corroborating his own observations, forgetting that this implies that he sees the originals only a fraction as well as he should.

Yet even so the photographs have surpassed our hopes, for they disclose more than one could have ventured to imagine. An eye versed in photographic perception and interpretation will easily see in them the canals as lines and the little spots, the oases, at their junctions. Indeed, the camera has shown itself capable of rising beyond the confirmatory into the discovery stage; for one of the plates of the writer was instrumental in the detection of a new canal. A stranger appeared on the plate which when searched for visually in consequence proved to be there. At the next opposition, with our newly devised improvements and with the planet so much nearer the zenith for northern observers, it is confidently to be expected that we shall do still more.

PERCIVAL LOWELL.

HYDROLOGY IN THE UNITED STATES.

IN some of the more recent reports on the hydrology of the United States, the book is prefaced by a general statement as to the intention and scope of the surveys that are being carried out by the geological department of the Government relating to the water resources of the country.

Water supply is regarded as one of the principal national assets, and of more importance to the life and pursuits of the people than any other natural resource. In the arid States the limit of agricultural development is determined by the amount of water available for irrigation. In other States, where the rainfall is greater and more evenly distributed throughout the year, the lack of rain at the proper season often reduces a crop to one-half what it would have been with one additional wetting at the time most needed. Storage, providing water for use when most wanted, will in such a case be as beneficial as where irrigation has to be depended on exclusively. This is especially the case in those districts where market gardening is one of the most profitable agricultural pursuits. Here irrigation is a necessity for making the business profitable.

The increase in the population of cities and towns makes necessary additional water supplies for domestic and industrial uses, in procuring which both the quantity and quality of the water that can be obtained must be considered.

The location of manufacturing plants may depend largely on the water-power facilities and the character of the water. Electric transmission of power has led to the utilisation of water-power for the operation of manufacturing establishments and lighting plants. Water-power is also largely used in some States for log driving, lumbering, and saw-mills, and also for the manufacture of paper from wood pulp and straw.

For all or any of these purposes a knowledge of the flow of the streams and of the conditions affecting that flow, based on trustworthy data, and of the underground resources is essential. For the want of this many schemes for water supply have ended in failure, the plans being made without sufficiently trustworthy information.

The United States Geological Survey has therefore, by means of appropriations by Congress, for several years systematically been engaged in obtaining records of stream flow, the number of stations at which streams were under observation in 1906 being 700. Records are also obtained in regard to floods, precipitation, the relation of the rainfall to run-off of water, evaporation, water pollution, the flow of underground streams, the use of artesian and surface wells, and generally all matters relating to water supply.

The reports relating to the above matters, and also as to the water resources of different States and districts, are issued from time to time, upwards of 200 reports having already been issued.

Notices of these reports, directing attention especially to those papers which are of general interest, have appeared in NATURE at various times.

The most recent reports of which we have received copies,¹ eleven in number, relate to the water resources of Georgia, New England, and other districts, the information contained in them being principally of local interest, except Paper No. 201, which has an introduction dealing with the system followed in obtaining the discharge of streams.

THE TESTING OF MATERIALS.

THE official report of the proceedings of the fourth Congress of the International Association for the Testing of Materials was recently issued. The congress was held at Brussels in September, 1906, and the report contains a condensed account of the reports presented and a summary of the discussions upon the reports and papers. The congress met in three sections, one dealing with papers on metals, another with papers on cement and artificial stones, and the third dealing with miscellaneous investigations, such as protection of metals against rust, testing of timbers, rubber, &c. Before the sections began their proceedings, Prof. Schüle delivered an address dealing with the life and work of the late president and founder of the association, Ludwig von Tetmajer.

One of the most important matters discussed in the metal section was the method of testing notched bars; after a lengthy discussion the congress eventually adopted the following resolution:—"The congress recognises that the method of testing notched bars appears capable of giving extremely interesting results." The congress did not, however, adopt a resolution which was moved to the effect that the method should be experimentally introduced into certain specifications.

In regard to the subject of ball-pressure tests, the congress eventually adopted the following resolution:—"The present congress desires that in the acceptance of metallic materials tests of tenacity should be supplemented as often as possible by a determination of the Brinell hardness number, the latter test being performed for the object of collecting information."

During the meeting of the association a metal-testing laboratory was installed at Brussels in order to show in action the various modern processes employed in the testing of materials. The tests made were micrographic, determination of the critical points, impact tests on notched bars, Brinell ball tests, and shearing tests. The congress has published a small illustrated pamphlet descriptive of the various testing appliances which were at work in this metal laboratory, with a brief note on the results obtained.

T. H. B.

UNIVERSITY AND EDUCATIONAL INTELLIGENCE.

CAMBRIDGE.—The Vice-Chancellor gives notice that the election of a professor of agricultural botany will take place on Monday, March 16. Candidates for this professorship are requested to communicate with the Vice-Chancellor on or before Wednesday, March 11.

Sir Ernest M. Satow, G.C.M.G., has been appointed to the office of reader on Sir Robert Rede's foundation for the present year. The lecture will be given in the Senate house on Saturday, June 13.

LONDON.—In connection with the supplementary vote of 6000*l.* for the Imperial College of Science and Technology at South Kensington, being part of the annual Government subvention of 20,000*l.* to the college, Sir Philip Magnus inquired last Friday in the House of Commons whether the 20,000*l.* was in excess of the cost of maintenance of the Royal College of Science and the Royal School of Mines, which had been incorporated in the Imperial College. In reply, Mr. Lough explained that the grant of 20,000*l.* was arranged by the Board of Education under the late Government; in addition, the Imperial College would have the fees paid by students, including fees paid by the Board of Education for scholars nominated by the Board. In reply to a further inquiry by Sir Philip

¹ Water Supply and Irrigation Papers. (Washington: Government Printing Office.)

Magnus whether the Government intended to appoint a Royal Commission in reference to the relation of the Imperial College to the University of London, no information appears to have been forthcoming.

OXFORD.—The annual report of the delegates for instruction in forestry shows that the average number of forestry students in 1907 was fifty-seven. The forest garden and experimental plantations in Bagley Wood have been much increased during the year, and the lack of accommodation is about to be met by the generosity of St. John's College. A block of buildings for the accommodation of the professor of rural economy was erected in Parks Road during the years 1906-7. It is now proposed to add further accommodation for the forest branch, consisting of a lecture theatre, a class-room, a museum, a library, and a professor's room. The new buildings will be ready by the end of 1908.

The degree of Doctor of Science has been conferred on Mr. E. H. J. Schuster, New College, for his contributions to biometrical science.

We learn from the *Revue scientifique* that by a decree of February 10, inspectors of technical instruction are to be appointed in France. Ordinary inspectors will be chosen from among the directors and teachers of technical schools, and district inspectors will be selected from competent leaders of industrial or commercial enterprises.

The Secretary of State for India has appointed a committee to inquire into and report upon the present system of selecting, and of training after selection, candidates for the Indian Forest Service, and to make recommendations. The committee is constituted as follows:—Mr. R. C. Munro Ferguson, M.P., chairman; Sir John Edge, K.C., member of the Council of India; Sir W. T. Thielson-Dyer, K.C.M.G., F.R.S.; Mr. E. Stafford Howard, C.B.; and Mr. St. Hill Eardley-Wilmot, Inspector-General of Forests in India.

The London Inter-Collegiate Scholarships Board will hold in May a combined examination for twenty scholarships and exhibitions tenable at University College, King's College, and the East London College. Candidates must have matriculated at the University of London or have passed an equivalent examination, and be under the age of nineteen years on October 1 next. The total value of the scholarships offered exceeds 1700l. Full particulars may be obtained from the secretary to the Board, Mr. A. E. G. Attoe, University College, Gower Street, London, W.C.

We learn from the *Times* that at the meeting of the council of the University of Paris on February 24, the Vice-Rector presented to that body a loving cup, a gift made by the University of London to the University of Paris as a souvenir of the hospitality it received last summer. The cup is silver-gilt, repoussé and chased, and is nearly 3 feet high. The lid is surmounted by an allegorical figure, while the body of the cup bears on its outside the arms of the Universities of Paris and London, two escutcheons emblematic of the French Republic and Great Britain, and three figures symbolic of science, letters, and art.

The Calcutta University will celebrate its jubilee this year by conferring the following honorary degrees at the Convocation to be held on March 14:—*D.Litt.*, the Hon. Sir A. H. L. Fraser, K.C.S.I., Lieut.-Governor of Bengal and Rector of the University. *D.L.*, the Hon. Sir Subramaniya Aiyar, K.C.I.E., Vice-Chancellor of the Madras University; the Hon. Mr. Justice Chatterjee, C.I.E., Vice-Chancellor of the Punjab University. *D.Sc.*, the Hon. Dr. Justice Mukerjee, Vice-Chancellor of the Calcutta University; Prof. A. Schuster, F.R.S.; the Rev. Father E. Lafont, S.J., C.I.E., late Rector of St. Xavier's College, Calcutta; Mr. T. H. Holland, F.R.S., director of the Geological Survey of India; Dr. G. Thibaut, C.I.E. *Ph.D.*, Dr. R. G. Bhandarkar, C.I.E., late Vice-Chancellor of the Bombay University; Sir Goroob Das Banerjee, D.L., late judge in the Calcutta High Court; Sir H. H. Risley, K.C.I.E., C.I.E., secretary to the Government of India; Prof. P. C. Ray, M.D., Surgeon-General

G. Bomford, C.I.E., Director-General of the Indian Medical Service.

AMONG the gifts to colleges and other institutions of higher education announced in *Science* during the past few months, the following, of 10,000l. or more, may be mentioned. By the will of the late Mr. D. Willis James 20,000l. was bequeathed to five separate institutions, including Columbia and Yale Universities. Prof. J. H. Hammond, by an additional 1000l., has brought his gift to the Hammond Metallurgical Laboratory of Yale University to 25,400l. By the will of Mrs. Sarah E. Potter, of Boston, Harvard University received a bequest of 10,000l., to be used in connection with the Gray herbarium. Columbia University has received an anonymous gift of 20,000l. Yale University has benefited to the extent of 10,000l. by the will of the late Mr. Silliman Bladen. Mr. John D. Rockefeller has added 438,200l. to his previous gifts to the University of Chicago, making the total amount of these nearly 5,000,000l. Colorado College has completed an addition of 100,000l. to its productive funds, towards which Mr. Andrew Carnegie contributed 10,000l. According to the daily papers, Bradley Polytechnic, of Peoria, Ill., benefits to the extent of nearly 600,000l. by the will of the late Mrs. Lydia Bradley. Mr. Andrew Carnegie has also given 40,000l. to Berea College and 15,000l. to Illinois College, at Jacksonville.

ANOTHER attempt at a settlement of the controversy relating to religious instruction in public elementary schools was introduced in the House of Commons on Monday in the form of a Bill brought in by Mr. McKenna, President of the Board of Education, "to regulate the conditions on which public money may be applied in aid of elementary education in England and Wales, and for other purposes incidental thereto." The Bill proposes that in future there should be but one type of public elementary school, provided, controlled, and managed by public authority, and the teachers to be appointed without religious tests. Every public elementary school receiving rate aid would thus be of the type of Board or County Council schools, and no child would be compelled to attend any other kind of school. The religious instruction given in these schools would be the same as that given in Board and county schools for the past thirty-eight years. Voluntary or Church schools would not have the support of public money in single-school parishes, for there the State would not recognise any other school than a public elementary school. In other cases, voluntary schools, when recognised as providing efficient instruction in secular subjects, would receive State aid in the form of grants, but no rate aid, the amount of the Government grant in both county and recognised voluntary schools being 47s. per annum for each child in attendance. The Bill was read a first time, after it had been vigorously condemned by Mr. Balfour and other members of the Opposition.

At the prize distribution to students at the Battersea Polytechnic on Wednesday, February 19, Lord Stanley of Alderley remarked that when the polytechnic movement was first started it was a general idea that the work in the institutions was to be largely recreative. But though the importance of the social side and of its influence for the good of the students was recognised, in course of time the educational work asserted itself and became predominant. In the more modern institutions, the value of the day work with its regular courses is being more fully recognised. While the evening work is kept up to as high a standard as possible, the work done in the day classes is more thorough; the students obtain a greater mastery of their subjects, and therefore it is of greater importance than that of the evening side. Remarkable advances have been made in this direction in the great technical institutions, such as those at Sheffield, Bristol, and Manchester. In the management of institutions like the Battersea Polytechnic, there should be a strong local element which knows what are the requirements of the particular districts. It is necessary to separate what may be called the common work of education from that of the particular work of technical instruction as applied to arts and crafts. A comparison between the requirements for domestic economy training a few years ago and those

which are now considered necessary to have any influence on the home life and habits of people shows that a much higher standard has been reached. The work carried on at the polytechnics will bear good fruit, and it is to be hoped that the London County Council will see its way clear to provide the means so that the polytechnics of London may furnish an example to every town in the United Kingdom and in all parts of the world.

The fifteenth annual general meeting of the Association of Technical Institutions was held on Friday and Saturday last at the hall of the Drapers' Company. Sir Horace Plunkett, the retiring president, occupied the chair during the early part of the proceedings, and was succeeded by Sir Norman Lockyer, K.C.B., who was unanimously elected president for the ensuing year. Sir Norman Lockyer in his address referred to the progress that has taken place in educational methods in recent years, but pointed out that there is a lack of coordination between primary and secondary schools or technical schools. We have now a good system of elementary education, but there is a terrible wastage after the primary school. He pleaded for a fuller recognition of continuity in education and of the high standing of technical institutions in an organic system. At the second day's meeting there was a discussion on trade or craft schools, and eventually the following resolution was adopted:—"That this association, fully recognising the necessity for a comprehensive and graded scheme of technical education, embracing all sections of the community, request the council to make an inquiry with a view to ascertaining the best conditions for the development of technical education in relation to the training of workmen." In opening the discussion, Prof. W. M. Gardner, of Bradford, said that of 1000 boys passing through elementary schools, and ultimately taking positions as industrial workmen, foremen, or managers, probably not more than forty pass through a secondary school and not more than three or four attend a day technical school. The great problem is, therefore, that of the boys who leave the primary schools at thirteen and fourteen, or even earlier, and who constitute 950 out of every 1000 boys of that age. Three courses seem to be open, namely:—(1) to provide specialised technical instruction during the latter portion of the primary-school course, combining it with the general subjects in the time-table; (2) to pass the lads forward from the primary school to specially arranged trade schools for one or two years; and (3) to rely, as hitherto, on evening schools for technical instruction. How far the first plan is practicable, or even desirable, appears doubtful. It is educationally unsound to give technical instruction in a trade without first dealing with the underlying sciences in an elementary manner. The provision of special trade schools seems, the speaker said, to offer a more likely solution of the problem.

SOCIETIES AND ACADEMIES.

LONDON

Geological Society, February 5.—Sir Archibald Geikie, K.C.B., Sec.R.S., president, in the chair.—Antigorite and the Val Antigorito, with notes on other serpentines containing that mineral: Prof. T. G. Bonney. It is not certain that the first described specimen of antigorite was really found in the Val Antigorito. The rock probably does not occur there *in situ*, though it is found in pebbles, &c., from tributaries. Other specimens of antigorite-serpentine were described. The origin of the mineral is discussed. Pressure is essential; it can be formed from augite, and there is evidence of its coming from this mineral.—The St. David's Head "rock series" (Pembrokeshire): J. V. Eisdon. These intrusions are of complex composition. There is a high magnesia percentage. There is no evidence of differentiation *in situ*, but the facts suggest a common origin from a differentiated magma basin. The rocks afford facilities for the study of both rhombic and monoclinic pyroxenes. Rhombic pyroxene generally crystallised earlier than the monoclinic pyroxene. There are two varieties of augite. The relation of these types lends support to the perthitic theory. The probable age of the intrusions is not greater than that of the earth movements which folded the Arenig shales in this district.

Linnean Society, February 6.—Dr. A. B. Rendle, vice-president, in the chair.—Specimens and lantern-slides of leaf impressions from the Reading beds: H. W. Monckton and O. A. Shrubsole.—Fruits and seeds from the pre-Glacial beds of Britain and the Netherlands, especially the Pakkeid specimens from the neighbourhood of Lowestoft (Cromer forest bed), and from Tegelen, near Venloo, in the province of Limburg, Netherlands: Clement Reid.—The use of large quantities of commercial concentrated soda carbonate when boiling refractory deposits: Mrs. E. M. Reid.—A botanical expedition to Central Fokien: S. T. Dunn. In April, May, and June, 1905, a botanical expedition was undertaken, with three native collectors and one Chinese herbarium assistant, to the centre of the province of Fokien. The difficult journey from Foochow to Yenping was successfully accomplished, and enough stores deposited at that town to enable a large collection of plants to be made. The central portion of this province, which is as large as England and Wales combined, had never previously been visited by a botanist, and, as might be expected, many novelties were discovered, and are here described, amounting to at least forty new species.—Some new *Aleynaria* from the Indian and Pacific Oceans: preliminary notice: Ruth M. Harrison.

Royal Anthropological Institute, February 11.—Prof. W. Ridgway, president, in the chair.—An additional note on New Guinea games: Dr. A. C. Haddon. The games were of various descriptions, and included a series of string figures.—A new instrument for determining the colour of the hair, eyes, and skin: J. Gray. The instrument was a simplified form of Lovibond's tintometer, by means of which hair-, eye-, and skin-colours could be classified by comparison with a series of standard coloured glasses. These standard glasses can be reproduced an indefinite number of times with the greatest precision by Lovibond's method, so that any number of observers can be provided with identical colour-scales. A series of locks of hair, arranged by the naked eye, from blonde to jet black, was exhibited, and curves showing the colour-elements of this series, as obtained by Lovibond's tintometer, were shown on the screen. The curves showed that the locks contained two coloured pigments, namely, orange and a yellow, and a black pigment. The black pigment increased uniformly in amount from blonde to black, and evidently formed the basis of the arrangement of the series by the naked eye, because the amount of orange and yellow pigment was practically constant throughout the whole series. A second series, of locks of red hair was exhibited, arranged by the naked eye from light to dark red or auburn. Analysis showed that the orange pigment was predominant, and formed the basis of the classification. A diagram, exhibited to show the correlation between orange and black in the two series of locks, pointed to the conclusion that red hair was derived from dark hair by the conversion of more or less of the black pigment into an equal amount of orange pigment, while fair hair was derived from dark hair by a reduction of both the black and the orange pigments.

Institution of Mining and Metallurgy, February 20.—Prof. W. Gowland, president, in the chair.—The alloys of gold and tellurium: Dr. T. K. Rose. An examination of the mixtures of gold and tellurium by means of the Roberts-Austen recording pyrometer, and observing polished sections under the microscope. The main conclusions arrived at were:—(1) A compound, $AuTe_2$ or Au_2Te , containing 43.59 per cent. of gold, and corresponding in composition to sylvanite or calaverite, is formed when gold and tellurium are melted together in certain proportion; this compound fuses at 452° . (2) Two eutectic mixtures are formed, containing 60 per cent. and 20 per cent. of gold respectively. These alloys correspond in composition to the formulæ $AuTe$ and Au_2Te . Under the microscope they do not show the characteristic banded eutectic structure, but there are certain indications that they are true compounds. (3) All the alloys of gold and tellurium are brittle. (4) All those containing less than 60 per cent. of gold fuse at temperatures between 397° and 452° .—A method of settling slimes, as applied to their separation from solution in cyanide treatment: H. G. Nichols. The principle involved is that of removing the

solid matter as it reaches the bottom of the tank in which it is settled by means of a conveyor belt. This process was found by repeated tests to give remarkable results both in the completeness of the separation effected and in the small proportion of liquid carried off by the solid matter.—Two detergents to the dissolution of free gold in the cyanide process: Duncan **Simpson**. These detergents are oil and lime, and the author gave examples showing their influence and the method adopted for counteracting it.—A rapid method for the estimation of arsenic in ores: H. E. **Hooper**.—The Indian mint assay of silver bullion: F. T. C. **Hughes**. A description of the methods employed in the Indian mints for the assay of the varying qualities of bullion received for coinage purposes. This process has been in vogue for upwards of fifty years, and has given satisfactory results, being specially suited to the condition of labour, &c., existing in India, and to the varied nature of the bullion operated upon.

DUBLIN.

Royal Dublin Society, January 21.—Prof. A. W. Conway in the chair.—The lines of flow of water in saturated soils, especially peat-mosses: L. F. **Richardson**. The author shows by means of experiments on "Bog of Allen" peat that the general velocity with which the water passes through the peat is proportional to the pressure gradient, and by utilising this fact he deduces the differential equations for the flow of water through peat saturated with water, neglecting capillarity, and assuming the peat to be isotropic in order to facilitate the mathematical treatment of the problem. The differential equations are solved by a freehand graphic method, and the form of the saturated water surface determined, when the tubes of flow are somewhat horizontal. From the diagrams thus obtained it is possible to calculate in a simple manner—the rainfall being given—how far apart drains must be cut in a bog so as to remove just the right amount of water, and conversely what will be the effect of a given cutting. The paper concludes with the description of another method for determining the conductivity of peat for water.—A simple form of apparatus for observing the rate of absorption of oxygen by polluted waters and by other fermenting liquids: Dr. W. E. **Adeney**.

EDINBURGH

Royal Society, February 3.—Prof. Andrew Gray, F.R.S., vice-president, in the chair.—Sensitive state induced in magnetic materials by thermal treatment: J. G. **Gray** and A. D. **Ross**. When steel is cooled from a high temperature, the first measured susceptibility in a given field is much higher than later measured values after the specimen has been subjected to cyclic magnetisations. This phenomenon, first noticed by Ewing, was studied in detail for steel, cast iron, cobalt, and soft iron. In soft iron the phenomenon is absent or present only to a small degree. In certain specimens of steel the effect was induced to a slight degree when the substance was raised to as low a temperature as 100° C. and then cooled; it increased with increased temperatures to about 700° C., but further increase of temperature had little influence. Mechanical vibrations considerably reduced the effect. The phenomenon was most marked in fields which gave large values of the susceptibility, tending to zero as the saturation point was approached.—The growth and development of the limbs of the penguin: Dr. D. **Waterston** and A. C. **Geddes**. The material had been brought home by Dr. W. S. Bruce, leader of the Scottish Antarctic Expedition. A comparison of the stages of development with the corresponding stages of development of the chick of a duck showed that the limbs of the penguin began at a fairly early stage to diverge in mode of growth from those of the duck, indicating that the adaptation of the fore-limbs for swimming purposes did not imply a degeneration from a form suitable for flight.

PARIS.

Academy of Sciences, February 17.—M. H. Becquerel in the chair.—The properties of pure starch: L. **Maquenne**. Referring to a note by M. Fouard at the last meeting of the academy on the isolation of a new

soluble form of starch, the author points out that this soluble starch is in all respects identical with that described by him, in conjunction with M. Roux, in the *Comptes rendus* two years ago. The name amylose was given to this soluble form of starch, and ordinary starch solution consists of a clear solution of amylose thickened with amylopectin.—Isotonic solutions and isosmotic solutions:

Yves **Delage**. A continuation of the controversy with J. Loeb. The author concludes that it is impossible to doubt that the parthenogenesis of the eggs of the sea-urchin can be brought about in solution isotonic with seawater.—The visibility of Saturn's ring on the side not lighted by the sun, and its reappearance in January, 1908: M. **Amann**. A detailed account of the appearances presented by the ring between October 4, 1907, and January 14, 1908.—The relation between flying shadows and scintillation: Cl. **Rozet**. A definite relation has been established between the shadow bands and the phenomenon of scintillation. The effects have been observed, not only with the sun, but also with Venus, Jupiter, Mars, and some stars of the first magnitude.—A theorem in the theory of integral equations: E. **Goursat**.—The electrolysis of solutions of hydrochloric acid: E. **Doumer**. In the electrolysis of hydrochloric acid, oxygen always accompanies the chlorine, the proportion of oxygen to the hydrogen set free at the other electrode depending on the concentration, and increasing with the dilution of the acid. With an anode of silver or mercury, capable of combining with the chlorine, the proportion of oxygen for the same intensity of current is increased. The author concludes that the electrolysis of both the acid and the water takes place simultaneously. The amount of oxygen produced is not negligible, and must be taken into account in the determination of the transport factor of the ions and in the measurement of the conductivity of these solutions.—Lithium in radio-active minerals: Mlle. **Geditsch**. Determinations of the copper, lithium, and the radio-activity compared with uranium have been made for the minerals thorite, Joachimsthal pitchblende, Colorado pitchblende, carnotite, chalcocite from Cornwall, and autunite. Lithium was found in all these minerals in amounts varying from 0.0017 per cent. to 0.03 per cent., and copper in all but autunite. These results prove that there is no simple relation between the amounts of copper and lithium in radio-active minerals.—A new method of estimating sulphur in organic substances: Isidore **Bay**. The substance is mixed with sodium carbonate and magnesium, and ignited in a current of oxygen. Test analyses are given showing the accuracy obtainable.—The separation of chloride and iodide of silver: H. **Baubigny**. A solution of ammonium carbonate can be used to effect the quantitative separation of silver iodide and chloride in the absence of bromide.—A method for the complete analysis of vegetable materials: J. M. **Albahary**.—The hydrolysis of perchloride of iron. The effect of the valency of the negative ions: G. **Malfitano** and L. **Michel**.—The reciprocal displacement of hydrocarbon groups in the Friedel and Crafts reaction: H. **Duval**.—The reducing properties of organo-metallic compounds: M. **Letellier**. By the action of ethyl-magnesium bromide upon ethyl oxypivalate, besides the glycol

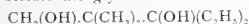

expected, the compound $\text{CH}_2(\text{OH})\cdot\text{C}(\text{CH}_3)_2\cdot\text{CH}(\text{OH})\cdot\text{C}_2\text{H}_5$ was obtained as a by-product. This is formed by the reduction of the ketone $\text{CH}_2(\text{OH})\cdot\text{C}(\text{CH}_3)_2\cdot\text{CO}\cdot\text{C}_2\text{H}_5$, ethylene being evolved. Other instances of the reducing action of alkyl-magnesium compounds are cited.—The simultaneous production of the 1:6- and 2:7-dimethyl-anthracenes in the action of CH_2Cl_2 , of CHCl_3 , or of $\text{C}_2\text{H}_5\text{Br}$, upon toluene in the presence of aluminium chloride: James **Lavoux**.—The essence of *Tetranthera polyantha*, var. *citrata*: Eug. **Charabot** and G. **Laloue**. The essences from the bark, leaves, and fruits were examined. That from the bark contained citral, citronellal, and an alcohol, possibly geraniol; the essence from the leaves contained citral, cineol, and the same alcohol as the bark; the essence from the fruits consisted of citral, an ester, and possibly geraniol.—The possible presence of microscopic diamonds on the sea floor and in a specimen of vegetable earth: J. **Thoulet**. The mechanical analysis

of a deposit obtained from the sea floor in the Bay of Biscay furnished some minute crystals many of the characters of which corresponded to those of the diamond, and similar crystals were obtained from a specimen of vegetable earth from the forest of Haye, near Liverdun. The quantities obtained were too small to admit of complete identification.—Contribution to the study of the alkaline rocks of Central Africa: L. Gentil and M. Freydenberg.—New observations on the anatomy and affinities of the Malpighiæa of Madagascar: Marcel Dubard and Paul Dopé.—The formation of the notochord in some larvae of the Tunicates: Louis Roule.—The mechanism of variations in height of the human body and some pathological variations: K. Robinson.—The statistical proof of Mendel's law: Angel Gallardo. An answer to some criticisms of Prof. K. Pearson.—The reproduction and the variations of development in *Glossina palpalis*: E. Roubaud.—The fixation of zinc by *Sterigmatocystis nigra*: M. Janvillier. A small proportion of zinc is favourable to the growth of this mould, and in solutions containing four parts per million of zinc or less the whole of the zinc present is fixed by the mould. With increasing proportions of zinc in the mycelium, increasing amounts of zinc are found in the mycelium, but the whole of the zinc present is not taken up. The *Sterigmatocystis* is capable of fixing without injury 1/100th of its weight of zinc.—The purgative action of phenolphthaleïn and its disodium derivative: C. Fleig.—The frequency of intestinal ulcerations in the course of an attack of influenza: Gabriel Arthaud.—Contribution to the study of the calorific radiation of the sun: G. Millochau and C. Féry.—The predominance of the erosion of the river Sarine on its right bank: Jean Brunhes and Cesare Calciati.

DIARY OF SOCIETIES.

THURSDAY, FEBRUARY 27.

ROYAL SOCIETY, at 4.30.—The Influence of Temperature on Phagocytosis: J. C. G. Ledingham.—The Cyto-genetic Changes in the Placenta and the Focus of the Pregnant Rabbit. A Contribution to the Chemistry of Growth: J. Leche and W. Cramer.—On the Maturation of the Ovary in the Guinea-pig: Prof. J. E. S. Moore and Miss F. Tozer.
ROYAL INSTITUTION, at 3.—Wood: its Botanical and Technical Aspects: Prof. W. Somerville.
SOCIETY OF DYERS AND COLOURISTS, at 8.—The Deterioration of Modern Dyed Leathers: M. C. Lamb.—A Note on the Germicidal Value of Petroleum Benzine: F. J. Farrell and F. Howles.

FRIDAY, FEBRUARY 28.

ROYAL INSTITUTION, at 9.—Explosive Combustion, with Special Reference to that of Hydrocarbons: Prof. W. A. Bone, F.R.S.
ROYAL SOCIETY OF ARTS, at 8.—The Removal of Dust and Fumes in Factories: Dr. J. S. Haldane, F.R.S.
PHYSICAL SOCIETY, at 5.—Contact Potential Differences Determined by Means of Null Solutions: S. W. J. Smith and H. Moss.—An Experimental Examination of Gibbs' Theory of Surface Tension as the Basis of Adsorption with an Application to the Theory of Dyeing: W. Lewis.

SATURDAY, FEBRUARY 29.

ESSEX FIELD CLUB (at the Essex Museum of Natural History, Stratford), at 6.—Artesian Wells on Fowlness Island, Essex, Ancient and Modern: W. H. Dalton.—On some Unexplored Fields of Essex Archaeology: John French.—Note on a Post-Glacial Deposit on Mersea Island, Essex: W. H. Dalton.

MONDAY, MARCH 2.

VICTORIA INSTITUTE, at 4.30.—The Atlantic Islands, and Origin of Their Fauna: Prof. E. Hull, F.R.S.
ARISTOTELIAN SOCIETY, at 8.—The Idea of Totality: Dr. S. H. Hodgson.

TUESDAY, MARCH 3.

ROYAL INSTITUTION, at 3.—Membranes: Their Structure, Uses and Products: Prof. W. Stirling.
ZOOLOGICAL SOCIETY, at 8.30.—A Comparison of the Neotropical Species of *Corallus*, *C. coneri*, with *C. macracanthus*; and on some Points in the Anatomy of *Corallus caninus*: F. E. Beaddar, F.R.S.—On a Young Female Kordofan Giraffe: Dr. P. Chalmers Mitchell, F.R.S.—Description of a New Species of Menkey of the Genus *Cercopithecus*: R. I. Pocock.
CIVIL AND MECHANICAL ENGINEERS' SOCIETY, at 8.—Notes on Engineering Works in Austria and Bosnia: A. S. E. Ackerman.
INSTITUTION OF CIVIL ENGINEERS, at 8.—Further discussion: The New York Rapid-transit Subway: W. B. Parsons.

WEDNESDAY, MARCH 4.

ROYAL SOCIETY OF ARTS, at 8.—Modern Dairy Practice: Loudon M. Dole.
GEOLOGICAL SOCIETY, at 8.—On *Metriorhynchus brachyrhynchus* (Deslog.) from the Oxford Clay near Peterborough: E. Thurlow Leeds.—The High-Level Platforms of Bodmin Moor, and their Relation to the Deposits of Stream-tin and Wolfram: G. Barrow.

ENTOMOLOGICAL SOCIETY, at 8.—Descriptions of New Species of *Lepidoptera heterocera* from South-east Brazil: E. Dukinfield-Jones.
SOCIETY OF PUBLIC ANALYSTS, at 8.—The Volumetric Determination of Reducing Sugars: Part II. The Limits of Accuracy of the Method under Standard Conditions: A. R. Ling and G. Cecil Jones. Part III. The Influence of Cane Sugar: A. R. Ling and T. Rendle.—(a) The Composition of Milk; (b) The Nitrogen Factor for Casein: H. D. Richmond.

THURSDAY, MARCH 5.

ROYAL SOCIETY, at 4.30.—*Probable Papers*—On the Atomic Weight of Radium: Dr. T. E. Thorpe, C.B., F.R.S.—On the Electrical Resistance of Moving Matter: Prof. F. T. Trouton, F.R.S., and A. O. Rankine.—On the Nature of the Streamers in the Electric Spark: Dr. S. R. Milner.—The Relation between Wind Velocity at 1000 Metres Altitude and the Surface Pressure Distribution: E. Gold.
ROYAL INSTITUTION, at 3.—Early British History and Epigraphy: Sir John Rhye.
CHEMICAL SOCIETY, at 8.30.—The Solubility of Iodine in Water: H. Hartley and N. P. Campbell.—Traces of a New Tin-group Element in Thorianite: Miss C. de Evans.
INSTITUTION OF ELECTRICAL ENGINEERS, at 8.—Fuse Phenomena: Prof. A. Schwartz and W. H. N. James.
LINNEAN SOCIETY, at 8.—On the Morphology of *Stigmara* in Comparison with Recent Lycopodiaceæ: Prof. F. E. Weiss.—On *Trichosteleites albidus* and *T. sarsi*: Alexander Patience.—*Exhibits*: Fruit Destroying Flies: W. W. Froggatt.—Mimicry in the Common Sole: Dr. A. T. Masterman.

FRIDAY, MARCH 6.

ROYAL INSTITUTION, at 9.—Recent Earthquakes: Prof. John Milne, F.R.S.
INSTITUTION OF CIVIL ENGINEERS, at 8.—Surveying on Thunder Bay Branch of the Grand Trunk Pacific Railway, Canada: R. V. Morris.—British Practice in Railway Surveying: W. Graham.—Railway Surveying in Great Britain: W. C. Crawford.

SATURDAY, MARCH 7.

ROYAL INSTITUTION, at 3.—Electric Discharges through Gases: Prof. J. J. Thomson, F.R.S.

CONTENTS.

PAGE

Man and Nature in South-West Africa. By Sir H. H. Johnston, G.C.M.G.	385
Alcohol and its Effects	386
Van der Waals and his Successors. By T. M. L.	387
American Forage Crops. By E. J. R.	388
Our Book Shelf:—	
Berberich: "Astronomischer Jahresbericht"	389
van Laar: "Lehrbuch der theoretischen Elektrochemie auf thermodynamischer Grundlage"	389
Tonge: "Coal"	389
Letters to the Editor:—	
The Speed of Racing Animals.—Prof. John Perry, F.R.S.	389
The Isothermal Layer of the Atmosphere.—W. H. Dines, F.R.S.	390
The Inheritance of "Acquired" Characters.—Dr. H. Charlton Bastian, F.R.S.; Dr. G. Archdall Reid; A. D. D.	390
The Possibility of Life in Mars.—C. O. Bartrum; Dr. J. W. Evans	392
The Stresses in Masonry Dams.—H. M. Martin	392
Three Animal Biographies. (Illustrated.) By R. L.	393
Studies in National Degeneration	394
Sir Richard Strachey, G.C.S.I., F.R.S. By Dr. W. N. Shaw, F.R.S.	395
Notes	397
Our Astronomical Column:—	
Saturn's Rings	401
The Objective Prism in Solar Spectroscopy	401
Comet 1907a	401
Uniformly Distributed Dark Spots on Jupiter	401
Double-Star Observations	401
Planetary Photography. (Illustrated.) By Prof. Percival Lowell	402
Hydrology in the United States	404
The Testing of Materials. By T. H. B.	404
University and Educational Intelligence	404
Societies and Academies	406
Diary of Societies	408

THURSDAY, MARCH 5, 1908.

THE EVOLUTION OF ASTRONOMICAL INSTRUMENTS.

Zur Geschichte der astronomischen Messwerkzeuge von Purbach bis Reichenbach 1450 bis 1830. By Joh. A. Repsold. Pp. viii+132. (Leipzig: Wilhelm Engelmann, 1908.) Price 16 marks.

IN all that relates to the mounting of telescopes or the construction of instruments intended for accurate measurements, in all that increases their convenience or adds to their efficiency, the firm of Repsold has won a world-wide reputation, and the book before us indicates in some measure the reason for this marked success. The head of the firm has been a keen and interested student of the history of past construction. For more than forty years, the author reminds us, he has been engaged in furthering the progress of instrumental construction, and in this time he has given close study to all that has effected the gradual development of this branch of engineering technique. He has assimilated all that experience can teach, has learnt the strength and the weakness of the work of past masters, and has profited by their example and their attainments. We now in our turn have the opportunity of benefiting by the results of this close study, perfected by much examination and sifting, and in addition to tracing the evolution of modern instruments we get glimpses of the history of astronomy, viewed from a new and interesting standpoint. Obviously, the connection between the progress of astronomical science and the improvement in instrumental equipment must be continuous and intimate, but how close the tie is can hardly be apprehended until we make a historical survey of the principles of instrumental construction, on a plan which reveals the part played by successive makers, and makes us understand to what extent astronomy has been forwarded by their endeavours.

Although the author limits his review from 1450, when Purbach strove to give expression to his mechanical ideas, to 1830, when Traughton in England and Gambey in France were representatives of the art of instrument making, the survey cannot be restricted to precise dates. At one end we listen again to the description of the contrivances of Ptolemy, which served for models through so many centuries, and at the other we are permitted to see the beginnings of the famous house of Repsold, destined to influence the methods of future artists.

The author passes in review the mechanical efforts of the Arabians, whose claims to consideration have been extravagantly championed by Sédillot and as stoutly disputed by Delambre. He acknowledges the skill of the devices which enabled them to solve approximately a particular class of problems by mechanical means, but cannot find much to praise in their measuring instruments. The astrolabe and the so-called "sextant" meet with adequate recognition, but a careful consideration of the facts, which are set out with the clearness bespeaking the practical expert, leaves the impression that the Arabians did very little

to advance the means for making accurate observation. They imitated, they did not invent, and none of the generic improvements which have facilitated the subdivision of small intervals of time and space—the main problem which has engaged the attention of successive generations of instrument makers—on which accurate astronomy depends, can be placed to their credit.

Frequent reproduction has made us familiar with the forms of the instruments used by Copernicus and Tycho, who with Hevel may be regarded as the last representatives of a pre-telescopic age. But here, in addition to very complete illustration, we have from the pen of a competent authority a full technical description of those contrivances, accompanied by acute and illuminating remarks on the adequacy of the design to secure the end contemplated, the faults of construction, and oftentimes the reason for the adoption of particular methods. Down the stream of time this discriminating but generous criticism is pursued, necessarily affording a clearer insight into the difficulties and successes of individual artists.

The introduction of the telescope offered a new set of problems for solution. The continual increase in focal length compelled makers to abandon the sector form of instrument, such as the quadrant, and forced upon them the necessity of devising more appropriate means for measurement, though Halley and Bradley both used 8-feet quadrants. The employment of complete circles and the designing of instruments of greater symmetry in their several parts were the consequence, and no one displayed more ingenuity or foresight than did Römer. With justice, the author carefully discusses the work of this astronomer, whose claims to recognition have been very tardily admitted, mainly owing to Delambre's jealous partisanship of Picard. But Dr. Repsold has known how to do justice to the one without injury to the other. Römer in various ways anticipated modern design. His *machina domestica* was the prototype of the present transit instrument, his *rota meridiana* of the meridian circle, while his azimuthal instrument foreshadowed the introduction of the convenient universal instrument. The use of two bearings to carry a long axis of rotation, increased symmetry of structure, the adaptation of the reading microscope, the practice of determining instrumental errors by suitable mechanical means, were all as fully appreciated by Römer as they are to-day.

Considering how indispensable a micrometer is to a telescope, and how materially it increases the scope and usefulness, its evolution proceeded slowly, but the study of its many transformations is of singular interest. The urgency of the demand for the means of measuring the diameter of a planet seems out of proportion to its importance, but the solution of the general problem, containing as it does that of the accurate and convenient subdivision of small spaces, taxed the ingenuity of instrument makers severely. Huyghens proposed a thin wedge, which could be moved in the focal plane until the planet was exactly occulted, when the measurement of the breadth of the wedge at that point gave the diameter. A net-

work of small squares in the focus of the eyepiece was another favourite device which might have answered very well if the object to be measured exactly fitted the side of the square. Picard seems to have first imagined the use of the screw to move two plates of metal, similar to the slit of a spectroscope, but to measure the distance, if we correctly understand the description, he had to detach the micrometer from the telescope and place it under an ordinary microscope. Hooke supplied the movable wires as an improvement to Gascoigne's micrometer, and Auzout introduced the divided head. Römer gave us the spring to take out the "loss" of the screw, Traughton added the position circle, and so the tale goes on, showing the variety of processes and the slowness of growth necessary to ensure the perfected form that receives general acceptance.

The processes followed in dividing the limbs of graduated instruments is another subject which the author's practical knowledge and great experience can render peculiarly interesting, but we can say no more than that in this treatise, with its admirable illustrations, will be found a valuable collection of facts from which one can trace that growth of mechanical skill and improved technique, which have ministered so materially to the progress of astronomical science.

NATURE AND NURTURE OF THE CHILD.

An Introduction to Child-study. By W. B. Drummond, M.B., C.M. Pp. iii+348. (London: Edward Arnold, 1907.) Price 6s. net.

The Child's Mind: its Growth and Training. By W. E. Urwick, M.A. Pp. xi+269. (London: Edward Arnold, 1907.) Price 4s. 6d. net.

MR. DRUMMOND, who is already well known as the author of a useful primer on the nature and nurture of the young child, has written a more ambitious book, which "aims at supplying a fairly comprehensive introduction to child-study." His work, therefore, necessarily covers a wide field, ranging from facts of growth, defects of the special senses, and school hygiene, by way of the instincts, habits and interests of children, to their forms of expression and their moral and religious characteristics. On all these he writes interesting chapters prefaced by sections dealing with methods of investigation and other introductory topics.

On p. 87 the student is wisely warned against the over-enthusiasm exhibited by "a number of workers especially in America," some of whom "start with no definite object in view and not unnaturally arrive nowhere." It would doubtless be unfair to suggest that this severe criticism applies not inaptly to the child-study movement as a whole. Nevertheless, on turning the last page of this book one is tempted to ask whether it is possible to secure "the chief end of child-study," which is, we are told, "not only to collect facts about children," but also "to formulate them in such a way as to make them available for science and for the use of those who need them for application to practical problems," so long as even

such able exponents as Mr. Drummond give us little more than a mass of materials of widely different values, not always submitted to adequate criticism, and illuminated from no general point of view. This complaint should, however, be qualified by recognition that the author can scarcely fail to encourage sympathetic observation of children—a result with which he would, apparently, be satisfied.

By contrast with Mr. Drummond's book, the systematic unity of treatment that follows from adherence to a clearly conceived point of view is the most prominent characteristic of Mr. Urwick's. The author of "The Child's Mind" sees clearly that:—

"It is not sufficient for the purpose of education merely to collect and state facts drawn from these sciences [Biology, Physiology and Psychology] which seem to be relevant. . . . The rays of light coming from the different sciences must be focussed, passed, as it were, through a common lens, in order that the light thrown may be cumulative and concentrated rather than sporadic."

It may be said at once that he has performed the task thus indicated in such a way as to make his modestly announced "study" one of the most useful pedagogical treatises of recent years. He has given what is much more helpful than the best "psychology for teachers"—a consistent interpretation of the educative process as a whole as it presents itself under the more or less conventional conditions which actually determine it.

Mr. Urwick's treatment is based upon the modern concept of connotation. Human behaviour can be analysed largely into connotative processes which set towards or away from objects of positive or negative "immediate value." In relation to these immediate values other objects of perception or thought may have "final value." Education consists in the (indirect) teaching of a certain range of immediate values and the (direct) teaching of final values with reference to these. Thus immediate and final value replace in Mr. Urwick's scheme the Herbartian notion of interest. His treatment is in a sense complementary to the older doctrine, of which he gives fragmentary but interesting criticisms. The student will find it a valuable exercise to study "The Child's Mind" together with a representative exposition of the Herbartian psychology such as that of Prof. Adams.

T. P. N.

OUR BOOK SHELF.

The Essentials of Cytology. An Introduction to the Study of Living Matter. With a Chapter on Cytological Methods. By Charles Edward Walker. Pp. viii+139. (London: Archibald Constable and Co., Ltd., 1907.) Price 7s. 6d. net.

The need for an elementary text-book on cytology has been felt for some years, and Mr. Walker has sought to meet it in the volume before us. There is much in the book that is good. The details of nuclear division in the higher forms are clearly presented, and the student is enabled to gain a clear idea of the process by means of the admirable and ingenious stereoscopic photographs which accompany the volume.

A considerable space is devoted to a consideration of the reduction phenomena which form such a striking feature in the cellular life-cycle of the great majority of animals and plants. But we cannot forbear from protesting against the introduction of what seems to us to be a totally unjustifiable confusion into current terminology. The term "meiotic phase," used to cover the processes connected with "reduction," was introduced to embrace the two mitoses which are intimately connected. In the course of the first of these the reduction in the number of the chromosomes is accomplished. Mr. Walker, however, speaks of the second meiotic division as post-meiotic, thus obscuring the close relationship that exists between the heterotype and homotype division, a relationship that is, partly at least, due to the fact that in the prophase of the first meiotic (heterotype) division, a fission in the chromosome rudiments takes place which will be consummated during the second (homotype) mitosis; this explains the common, though not invariable, absence of the spireme from the second division, and probably is connected with the rapidity with which the two mitoses usually follow on each other. The term post-meiotic should be (as it hitherto has been) reserved for those mitoses, if any, which occur after the completion of the meiotic phase.

The description given of polar bodies is made, doubtless by inadvertence, to read as though these structures only represented nuclei and not cells, whereas, of course, they are each severally homologous with the egg.

The book would be improved by the substitution of a more comprehensive account of the nuclei of the lower organisms for the matter contained in chapters x. and xi., which seems to us to be somewhat out of place in a work of this kind, as well as open to criticism on other grounds.

The addition of an introductory chapter dealing with the development of our knowledge of the cell, and the recognition of its paramount importance, would be useful when there is a demand for a second edition, and at the same time the references which appear at the foot of some of the pages might also be completed.

We have criticised the work somewhat frankly, perhaps, but this has been done not with the intention of condemning it. On the contrary, it possesses many very good qualities, and with some little modification and correction, it will easily rank as an extremely useful text-book of elementary cytology. J. B. F.

Immune Sera. By Dr. C. F. Bolduan. Second edition, re-written. Pp. viii+154. (New York: John Wiley and Sons; London: Chapman and Hall, Ltd., 1907.) Price 6s. 6d. net.

This book has its origin in a monograph by Wasserman, a translation of which was published by the author in 1904. This second edition has been re-written by the translator. The original chapters are dealt with more fully, and the scope of the book has been widened by the addition of chapters on venins and antivenins, agglutinins, opsonins, and serum-sickness.

The antitoxins are first dealt with, and brief outlines are given of the history of the subject and of the methods of preparing and testing antitoxins. Ehrlich's views on the origin of antitoxin, on the constitution of diphtheria antitoxin, and on the nature of the combination between toxin and antitoxin, are treated in a lucid manner. The views of Arrhenius and of Bordet receive less adequate treatment.

In handling the subject of the agglutinins, the bacteriolyins, the hæmolysins, and the precipitins,

much discrimination has been shown in avoiding a discussion of the more difficult theoretical considerations, and in selecting the fundamental facts and experiments for exposition.

A good account is given of the application of hæmolytic and precipitin methods to practical purposes. Among these may be mentioned methods of great importance in medico-legal work, viz., the biological tests for bloodstains by means of which it is possible to differentiate human blood from the blood of other animals.

The least satisfactory chapters in the book are those on serum sickness, snake venoms, and opsonins. In regard to the last, the author states that the results obtained by most workers in America fail to bear out Wright's claims for his method.

On the whole, this is an excellent little book, and ought to be of service both to those who wish to keep abreast of the main advances in the subject and to those who are attacking these questions for the first time.

A Guide to the Study of Australian Butterflies. By W. J. Rainbow. Pp. 272; illustrated. (Melbourne: T. C. Lothian, 1907.) Price 3s. 6d.

This is a useful little book intended for beginners taking up the study of Australian butterflies, with special reference to their life-history. Indeed, the author not only tells us in his preface that "much of the material in the way of life-histories is now published for the first time," but also, "Only those species of which something is known of their life-history are included in the present volume." Surely this last resolution is a double mistake. On the one hand it will be a great disappointment to any collector who meets with one of the purposely omitted species not to be able to discover from this book (perhaps the only one on the subject to be found within hundreds of miles) whether his find is known, or probably new; and, on the other, if attention had been directed to imperfectly known species, it would have largely conduced to efforts being made to supply the deficiencies in our knowledge. The book otherwise, however, seems to be very well executed, and is remarkable for being written almost entirely from Australian sources.

The classification followed is taken from Mr. G. A. Waterhouse's "Catalogue of the Rhopalocera of Australia." The frontispiece represents two handsome species of *Delias* and two of *Papilio*, while most of the species mentioned in the book are excellently figured, figures of the earlier stages being frequently added. The introductory chapters deal with transformations, parasites, collecting and preserving, &c., and are also freely illustrated, the figures of wing-venuration on p. 23 being particularly good. Ninety species are included in this little volume, distributed among six families as follows:—Nymphalidæ (sens. lat.), 35; Libytheidæ, 1; Lyciniidæ (*sic*), 16; Pieridæ, 12; Papilionidæ, 9; Hesperidæ, 17.

We notice a few peculiarities in the spelling of some of the names, which appear to be not misprints, but intentional, such as *Xenica kluggi*, and *Lycinidæ*.

W. F. K.

The Theory and Practice of Perspective Drawing. By S. Polak. Pp. viii+184. (London: University Tutorial Press, Ltd., 1907.) Price 5s.

This volume of the "Organised Science Series" has been specially compiled to meet the requirements of the Board of Education's syllabus in perspective, and covers the ground of both sections A and B of that syllabus with their direct and inverse problems.

The method of treatment adopted by the author is one likely to be very effective in teaching; new principles and processes, as they arise in the natural development of the subject, are illustrated and driven home by the use of models, diagrams, and repeated applications to suitable problems, so that the conscientious student is always fully conversant with the reasons for his geometrical constructions. The very excellent and suggestive questions from the examination papers of the Board of Education for the last five or six years are freely employed, both in the text and as sample test papers, affording a good criterion of progress.

In addition to the ordinary geometrical solids, many familiar objects the forms of which can be dissected into simple geometrical figures are used as examples. After the student has thoroughly mastered the fundamental principles as set forth in part i., he should experience comparatively little difficulty with the three succeeding parts, which extend the subject to lines and planes obliquely situated, to shadows by parallel and divergent rays, and to reflections in horizontal and vertical mirrors. The book will be very acceptable both to teachers and students of this interesting branch of applied geometry.

Strength of Materials. By W. C. Popplewell. Pp. x+180. (Edinburgh and London: Oliver and Boyd, 1907.)

THIS text-book, which is based on the notes of lectures given by the author to day and evening students at the Manchester Municipal School of Technology, deals with the fundamental principles which must be mastered by every student who wishes to have a sound knowledge of machine and structural design. Special attention has been devoted to the effects of unequal distribution of stress, and in chapter vii. the author gives details of his own experimental work in connection with this branch of the subject. The last three chapters give an account of the methods adopted and appliances required in making tests of the various materials used in constructional work, and the important subjects of limit of elasticity and of the influence of previous loading, &c., upon the limit are discussed. In an appendix is given a table of strengths and weights of a large number of different materials, and there is a collection of useful examination questions for each chapter.

LETTERS TO THE EDITOR.

[The Editor does not hold himself responsible for opinions expressed by his correspondents. Neither can he undertake to return, or to correspond with the writers of, rejected manuscripts intended for this or any other part of NATURE. No notice is taken of anonymous communications.]

Lithium in Radio-active Minerals.

THE recent results of Mlle. Gleditsch (*Comptes rendus*, cxlvi., p. 331) corroborating those of Prof. McCoy, viz. that lithium is generally, but not always, a constituent of radio-active minerals containing copper, and that there is no fixed proportionality between the copper and the lithium in these minerals, must not be taken to have the exclusive significance which their authors attribute to them. As explained in our original communication to the Chemical Society, we are inclined to believe that sodium, and perhaps also potassium, are products of the degradation of copper salts when in contact with radium emanation. As both these metals are constituents of ordinary glass, and as the experiments were carried out in glass vessels, the only argument which was used was that the weight of the residue from the treated was greater than that from the untreated copper salt. Lithium was mentioned because it is an unlikely constituent of dust, glass, copper, &c., which were tested specially to prove its absence; it was certainly contained in the treated residue. Inasmuch as

the emanation in contact with water yields neon, on the probable supposition that monatomic gases are produced from the emanation, it would follow that the production of any particular one is dependent on surrounding conditions. It will be remembered that the gases from the action of the emanation on a solution of copper sulphate contained no helium, but probably argon. As sodium and potassium are much more widely distributed than lithium, it is more likely that they are the chief products from copper, and that some modifying circumstance has determined the formation of a trace of lithium. Experiments now in progress in silica vessels will settle this point. Numerous chemical analogies might be adduced in favour of this view. For example, the action of bleaching powder on ammonia solution is to give nitrogen for the most part; if much ammonia be present, and if glue or some other colloid be present, hydrazine is the chief product. One can only be guided by such analogies in determining the lines of future experiments. W. RAMSAY.

Formation of Ground-ice.

IN Canada we have made an extended study of the formation of ground-ice, or anchor-ice as it is called here, and consequently I was interested to see a letter in NATURE of January 30 from Mr. Hampson asking for information as to its origin.

May I at the outset refer Mr. Hampson to four papers published many years ago which are wonderfully interesting to anyone studying the formation of ground-ice? Two of the papers appeared in the *Edinburgh New Philosophical Journal*, one by M. Arago, vol. xv., p. 123, 1833, and the other by the Rev. Mr. Eisdale, vol. xvii., p. 167, 1834. The two other papers were published in the *Phil. Trans.*, vol. cxv., p. 329, 1835, and vol. cxxi., p. 37, 1841, by the Rev. James Farquharson, of Alford.

In reply to the questions raised by Mr. Hampson, I may say that (1) the essential conditions for the formation of ground-ice on the bed of a river are clear weather conditions at night with the water at or near the freezing point, excessively low air temperatures by day, with no sunshine and no surface ice or other cover such as overhanging weeds or a bridge to check the nocturnal radiations. The answer to (2) is covered by the above. (3) A flowing river becomes stirred by eddy currents, and hence the cold surface layers find their way to the bottom. We notice many of our large rivers flow with a rolling motion. (4) The water is such a bad conductor of heat that it is only by the mechanical action that the bed of a river becomes cold enough to form ice on it when aided by radiation, or, as I have shown, by a slight supercooling in the water. (5) Ground-ice will form in water of any degree of agitation provided either or both of the causes mentioned in (4) are operating. In the case Mr. Hampson cites of the mill, I should say the heat generated by the water flowing through the mill would tend to prevent the formation of ice on the lower side.

In Canada we have anchor-ice formed in very large quantities in all the waterways flowing too swiftly for surface-ice to form. In some parts of the St. Lawrence it grows 5 feet or 6 feet in depth, forming very rapidly during the periods of intense cold and clear nights. On bright days the sun's radiant heat brings large quantities of it to the surface with much noise and disturbance. The buoyancy of large masses of the ice is often great enough to raise huge stones and boulders and carry them along in the current, depositing by this means portions of the river bed further down stream in the quieter waters. Boatmen are very careful not to cross the river when anchor-ice is rising, for fear of having a large mass come up under them and carry the boat helpless into the rapids. Under surface-ice, with its covering of opaque snow crystals, anchor-ice does not form, and hence it causes no trouble under these conditions.

Anchor-ice is known and studied in every country in the world where ice is formed, and there is much that might be written about it. In NATURE of January 17, 1907, a careful review of my book on "Ice Formation," with special reference to anchor-ice and frazil, was given, and may help to answer some of the questions in the "long list" mentioned by Mr. Hampson. My paper read

before Section G at the Leicester meeting of the British Association, and published with illustrations in *Engineering* for August, 1907, will convey some idea of the ice problem as presented to the users of "white coal" in Canada. In Russia, M. Wladimirov has published several important papers on his studies of the ice conditions on the Neva, in connection with the Waterworks Commission of St. Petersburg. One thing is well established, and that is that the formation of natural ice such as ground-ice, whether in Great Britain, Canada, Russia, France, Germany or elsewhere, conforms to the known laws of nature. Not a single known case of natural ice formation has ever come under my notice which has not its possible duplication in a laboratory experiment. The two differ only in the magnitude of their effects.

H. T. BARNES.

McGill University, Montreal, February 10.

The Possibility of Life on Mars

MR. DINES's important letter on the "Isothermal Layer of the Atmosphere" has obviously an important bearing on the question of the gases that have been retained or lost by the atmosphere of Mars. If the temperature of our atmosphere ceases to decrease when a height averaging 35,000 feet is reached, and then remains practically constant at an average temperature of -47° C. whatever height be attained, we may expect somewhat similar conditions to prevail in the atmosphere of Mars, and naturally ask what are the temperatures which will allow of the escape of the different gases.

This question can be easily answered by a brief calculation from the data furnished on pp. 113 and 325 of Jeans's "Dynamical Theory of Gases" (1904). We find that at a temperature of -175° C. hydrogen will be "certainly retained," while at -65° C. it will be "certainly lost." The corresponding temperatures for helium will be -81° C. and 136° C., and for water vapour 599° C. and 1583° C. From these figures it results that if the temperature of the isothermal layer of Mars be the same as the temperature of that of our atmosphere, hydrogen will be lost, helium probably retained, and water vapour clearly retained. I should imagine that in the case of Mars the isothermal layer will be much colder, especially as the carbonic acid that is present in the atmosphere of that planet will be concentrated in the lower levels.

Neither Prof. Lowell nor Dr. Russel Wallace appear quite to have realised the importance of the influence of carbonic acid on the atmospheric temperature at the surface of the planet.

It is now a commonplace of geology that a variation in the small percentage of carbonic acid in the earth's atmosphere will have an important effect on the temperature of the latter, though authorities differ as to the numerical amount of the variation required to produce a given change of temperature under given conditions. If the atmosphere contains a relatively large amount of carbonic acid, a correspondingly greater proportion of the heat received will be retained, and the temperature will be higher. Such conditions will be marked by luxuriant vegetation, and at the same time rapid formation of carbonates by the action of water containing carbonic acid on silicates and other minerals. This will eventuate in a period when there is less carbonic acid in the air, and colder conditions will prevail. The growth of vegetation and the decomposition of minerals will be checked and confined to the warmer portions of the earth's surface. The supplies of carbonic acid from intratelluric sources will then gradually add to the amount of carbonic acid in the atmosphere, bringing an increase in temperature with it.¹ There are features in the geological record which lend support to the view that such a cycle of changes has occurred more than once in the earth's history.

If, now, we make the very reasonable assumption that the crust of Mars is composed of the same minerals as those with which we are familiar, and its atmosphere of the same gases as ours, and that accessions of carbonic

¹ I have stated the theory in its simplest terms. There are other circumstances that affect the amount of carbonic acid in the air. Prof. Chamberlin believes that the sea plays an important part in absorbing or giving out the gas according to the conditions that prevail.

acid are received from the interior of the planet, we may expect a similar automatic adjustment of the temperature so that it is never too cold for the chemical reactions of carbonic acid in solution to take place, and for vegetation, such as that believed to exist by Prof. Lowell, to maintain itself somewhere on the surface of the planet. The amount of carbonic acid required for the purpose will, of course, be greater than that in our atmosphere, but there is no reason to believe that it would reach an amount which would be injurious to the life of plants or animals, even if such were similar in nature to those on the earth.

Whether Prof. Lowell can be considered to have established his views is a question on which I do not feel called upon to express an opinion, but I confess that the arguments advanced against them do not strike me as convincing. They remind me of those of the engineers who satisfied themselves that a locomotive could not draw a train of trucks on smooth rails, and were not persuaded to the contrary until they saw that it did so.

Imperial Institute, February 28.

J. W. EVANS.

A Fundamental Contradiction between the Electrical Theory of Dispersion and the Phenomena of Spectrum-series.

THE electrical theory of dispersion is based on the hypotheses (1) that electric waves are due to motions of electric charges, and waves of light in particular to vibrations of charges inside the atom; and (2) that these vibrations are governed by linear equations. On this basis we obtain the usual dispersion formulæ, e.g. that of Drude:—

$$n^2 - 1 = \sum \frac{N_e e^2}{\pi m_e \nu} \frac{\lambda_h^2}{1 - \lambda_h^2/\lambda^2}$$

where n is the refractive index for wave-length λ , λ_h one of the free periods of a set of electrons in the atom, e the charge, m_e the mass, and N_e the number per c.c. of the electrons of the set, while the summation is for all possible free periods of the atom. In particular, if λ be greater than every one of the free wave-lengths of the atom, we get

$$n^2 - 1 \approx \sum \frac{N_e e^2 \lambda_h^2}{\pi m_e \nu}$$

Consider the contribution of all the lines of the well-known Balmer series to the dispersion of hydrogen; for this series

$$\lambda_h = \lambda_{\infty} \frac{m^2}{m^2 - 4}, \quad m = 3, 4, \dots, \infty,$$

where

$$\lambda_{\infty} = 3646 \cdot 13 \text{ \AA.}$$

Its contribution exceeds

$$\sum_{m=3}^{m=\infty} \frac{N_e e^2 \lambda_h^2}{\pi m_e \nu} \approx \frac{m^4}{(m^2 - 4)^2}$$

If the theory is to account for the lines of the series at all, the factor $N_e e^2 \lambda_h^2 / \pi m_e \nu$ cannot vanish for any line; let A be its least value. Then the contribution exceeds

$$A \sum_{m=3}^{m=\infty} \frac{m^4}{(m^2 - 4)^2}$$

The sum is obviously infinite; but all experience shows that for long waves the refractive index of hydrogen is nearly unity, and finite even for luminous hydrogen.

The same result follows for any series formula which implies that a series has (1) a tail; (2) an infinite number of lines the wave-length of which exceeds that of the tail, that is, for all known formulæ which agree with measurements either of line or of band series.

Thus we must either reject the usual notion of a series, and with it all the formulæ which represent our experience best, or we must reject the hypothesis that series lines are due to small vibrations of electric charges governed by linear equations, and with it the usual theories of dispersion and absorption, of the Zeeman effect and of magnetic rotation for series lines.

G. A. SCIOTT.

Physical Institute, Bonn, February 17.

NOTES ON ANCIENT BRITISH MONUMENTS.¹

VI.—DOLMENS.

IN some previous notes I have given an account of some measurements of the so-called "cromlechs" of Cornwall. In referring to this subject in a more

Theoretical value of May-year azimuths.

	May		November	
	True	Magnetic	True	Magnetic
1½ hill: retraction and semi-diameter	N. 64 26 ...	S. 81 6 ...	S. 61 50 ...	134 50



FIG. 18.—Devil's Den, Avebury, looking towards November sunrise.

general manner, it will be well, I think, *pour préciser les idées*, to refer to the word itself. In English works on archaeology it is used as a variant for dolmens, chambered barrows, chambered cairns, and kistvaens, while in France it is applied to the more or less irregular circles and groups of stones associated with avenues; and there the equivalents of the Cornish "cromlechs," which exist in great numbers, are invariably called dolmens.

It is convenient, therefore, to use the word dolmen when such structures are considered separately from the circles.

With regard to the examples available for measurement in Cornwall, the important, and indeed striking, conclusion was arrived at that almost all those given by Lukis were erected so that the sunrises at the May-year or solstitial festivals could be plied to other localities, and referred to other similar structures in S. Wales which gave the same results.

I now propose to go further afield, with the view of inquiring whether this law applies to other localities, and I will begin with one I have myself measured, the Devil's

Den at Avebury. The conditions at Avebury are as follows:—Lat. N. 51° 25'. Magnetic variation, 16° 40' W., 1906.

¹ Continued from p. 371.

My wife and I visited the Devil's Den, in company with Mr. R. H. Caird, in July, 1906, and again in August, 1907. The compass bearing was N. 134° E. looking eastward through the aperture formed by the three stones, and the height of the horizon in this direction was 1° 25', thus agreeing with the value of the November sunrise given in the table.

Here then, as in Cornwall, the November and February sunrises, when the sun has a S. declination of 16° 20', are in question.

It is well known that two of the most famous long barrows in England with their included dolmens are close to Avebury; one of them, the "West Kennet Long Barrow," is described in Smith's "British and Roman Antiquities of N. Wiltshire," p. 154. I condense his reference:—

"The 'West Kennet Long Barrow,' indeed, is one of the most notorious, as well as one of the largest of the Long barrows in the kingdom; and although it is much cut about, with a waggon-track passing over the centre of it, a confusion of large sarsens tumbled together at the east end, and several big trees occupying its sides,



FIG. 19.—Devil's Den, looking towards May sunset.

Den at Ave-

bury. It is still of imposing appearance. Let us first see what our old Wiltshire antiquaries thought of it, and then what it proved to be, when opened by Dr. Thurnam. Aubrey gives but a brief and very inaccurate description: "On the brow of the hill, south

from West Kynnet, is this monument, but without any name: It is about four perches long, but at the end only rude grey-wether stones tumbled together. The barrow is about half a yard high.¹

Stukeley says of it²: "The other Long barrows are much exceeded by South Long Barrow, near Silbury Hill, south of it, and upon the bank of the Kennet. It stands east and west, pointing to the dragon's head on Overton Hill. A very oporose congeries of huge stones upon the east end and upon part of its back or ridge, pill'd one upon another, with no little labour. . . . The whole tumulus is an excessively large mound of earth 180 cubits long, ridg'd up like a house."

Sir R. Hoare's account of it³ is as follows:—"There are several stupendous Long barrows in the neighbourhood of Abury: one of the most remarkable has been recorded by Stukeley as situated south of Silbury Hill. It extended in length 344 feet; it rises, as usual, towards the east end, where several stones appear above ground: and here, if uncovered, we should probably find the interment, and perhaps a subterraneous kistvaen."

Dean Merewether states⁴:—"At the east end were lying, in a dislodged condition, at least thirty sarsen stones, in which might clearly be traced the chamber formed by the side uprights and large transom stones, and the similar but lower and smaller passage leading to it: and below, round the base of the east end, were to be seen the portion of the circle or semi-circle of stones bounding it."

I have given this somewhat long account because it shows that all information relating to orientation is omitted from it; it is generally, indeed, neglected by modern archaeologists. Even Stukeley himself, though he was thoroughly acquainted with magnetic variation and at times used a theodolite, is caught napping in the case of this barrow. Fortunately, however, the apparently useless statement that the barrow points to the dragon's head on Overton Hill helps us, as this was a circle the site of which is known, though the stones have disappeared. This bearing (true) is N. 64° E. as determined from the 6-inch Ordnance map.

Here again, then, we deal with the May year and the May and August sunrises, still another argument in favour of Avebury and its region being connected with the May year.

I may next refer to some cromlechs near Dublin (lat. 53° 20' N.), which were described by Prof. J. P. O'Reilly.⁵ I give the results of his stated amplitudes in tabular form:—

Cromlech	Value given	Azimuth	Hill	Declination
Glen Druid... E. 24 30 N. ... N. 65 30 E. ...			(assumed)	14 20 N.
Howth... .. E. 27 0 N. ... N. 63 0 E. ...			(assumed)	15 44 N.
Mount Venus E. 23 28 N. ... N. 66 32 E. ...			0	13 5 N.
Shankill " " " " " " " "			"	" "
Larch Hill " " " " " " " "			"	" "

It will be seen that here again we are in all probability dealing with the May and August sunrises, when the sun has a declination of 16° 20' N.

It is to be regretted that in Borlase's fine book on the dolmens of Ireland, the lack of all accurate statement touching the lie of the monuments renders its thousand pages and hundreds of illustrations quite useless for my purposes.

¹ From MS. in the Bodleian Library at Oxford, quoted in "Archæologia," vol. xxxviii., p. 407.

² "Abury Described," p. 46.

³ "Ancient Wilt., North," p. 96.

⁴ Proceedings of Archaeological Institute, Salisbury volume, pp. 97, 98.

⁵ Proc. R.I.A., iv., pp. 589-605 (1896-8).

After what I have suggested as to the probable use of dolmens, namely, that they were useful among other things as look-out places, it is not to be expected that only the rise of the sun would be found provided for. They should follow the precedent of the avenues, and be presented to star as well as to sun rise.

In two instances known to me the information is complete enough to enable a stellar use to be traced.

The first is at the Hurlers. Full details have been already given in my "Stonehenge."

The second is at Callernish (Turnsachan, lat. 58° 12' N.). A good description of the stone monuments there, which include a circle, avenue and cromlech, is given in Anderson's "Scotland in Pagan Times" ("The Bronze and Stone Ages," p. 119).

They were, fortunately, also carefully surveyed by Sir Henry James.

We learn from Anderson that:—

"In 1858, Sir James Matheson caused the peat which had grown on the site of this monument to be removed. The average depth of the peat from the surface to a rough causewayed basement in which the stones were imbedded was 5 feet. In the process of the removal of this accumulation, the workmen uncovered the remains of a circular cairn, occupying the space between the centre stone and the east side of the circle. In the centre of the cairn was a chamber with regularly built internal walls, and a passage leading from it to the outside of the cairn, the opening being placed between two of the stones of the circle. The chamber was divided into two compartments by slabs placed across the floor, leaving an opening between their edges a little less than 2 feet wide. Beyond these slabs the inner compartment was formed of dry-walling in the sides, and a long slab set on edge at the back. The passage was about 6 feet in length, and 2 feet wide, entering the chamber between two slabs set on end facing the two on each side of the entrance to the inner compartment. The first compartment was 6 feet 9 inches from side to side, and 4 feet 3 inches from front to back, the second, 4 feet 4 inches from side to side, and 2 feet 1 inch from front to back on the floor, widening upwards in consequence of a slight inclination of the slab at the back. With the exception of a single stone, which was supposed to have been a lintel, there was no appearance of a roof, and there is nothing on the record of the excavation to show whether the roof of the chamber had fallen in, or whether it had been removed. It is not even stated what was the height to which the side-walls were found standing. But it is obvious at a glance that here we have a very peculiar construction,—a cairn containing a chamber divided into compartments, and furnished with a passage opening to the outside of the cairn."

From Sir H. James's plan we get the data necessary for orientation purposes. They are as follows for the sight-line from the chamber:—

Az.	Horizon (true map)	Decl.	Star	Date
N. 74 30 E. ...	1 18 ...	8 54 N. ...	Pleiades ...	1330 B.C.

In 1330 B.C. and lat. 58° 15' N. the Pleiades warned the May sun by about 1½ hours; in 1901 B.C. the warning was of about 1 hour duration. Thus, taking into account the high latitude, with the consequently extended dawn, the Pleiades warning was more effective in 1300 B.C. than it would have been at the earlier epoch, at which, as I have previously shown, the stones of the long avenue were probably erected.

Prof. Morrow has recently sent me measures of the side walls of the curiously structure on the N.E.

side of the circle of Keswick. These are doubtless to be considered in relation to the direction of the chambered cairn at Callernish. The rising of the Pleiades seems to have been in question.

Still another stellar dolmen I measured in S. Wales has already been referred to.

NORMAN LOCKYER.

EXPERIMENTS ON SCREW PROPELLERS.¹

THE screw-propeller was practically applied to steamships by John Ericsson and Francis Petit Smith about seventy years ago. It speedily became a formidable rival to the paddle-wheel. Long ago it entirely superseded the latter for ocean navigation, and in more recent years it has to a large extent taken the place of the paddle, even in river steamers of the shallowest draught. Accumulated experience over this long period has proved of great advantage, and has enabled naval architects and marine engineers to meet new conditions in ships of much larger dimensions and higher speed; but notwithstanding this wealth of experience—largely based upon "progressive trials" of steamships and the analysis of the results—it is still true that we are on the threshold of exact knowledge in regard to the principles underlying the efficiency of screw-propellers.

Even in recent years, when the limits of experience have had to be surpassed, there have been many proofs of imperfect knowledge. On the whole, it is true that success has been achieved, but not infrequently as the result of numerous and sometimes costly experiments on propellers of different forms. Perhaps the most striking example of this general truth is to be found in the case of torpedo vessels and motor boats, driven at extraordinarily high speeds in proportion to their dimensions; it is also true that, in vessels of large size and of less speed in proportion to their dimensions, remarkable results have been obtained by a simple change of propellers. For instance, the *Drake* class of cruiser in the Royal Navy, which are the fastest cruisers afloat, had a guaranteed speed of twenty-three knots on an eight hours' trial. The guarantee was slightly exceeded in the first trials, but there was evidence that the propellers became relatively inefficient as the highest speeds were approached, and that the blade-area was insufficient. New propeller blades were made with greater blade area, and with these the ship was driven at a speed exceeding twenty-four knots, representing a gain of about 25 per cent. in efficiency. Obviously, incidents of this nature point to the possibility of very large economies if our knowledge of screw-propeller action and efficiency could be made more definite as well as more extensive. Trials in actual ships, especially those of large size, are necessarily costly, and are often impossible to make because the vessels are required on service. Hence, at a very early date, attempts were made to introduce a system of experiments with model screw-propellers, and from these useful information was obtained. It was left for the late Mr. William Froude to perfect the method of experiment in connection with his well-known system of "tank" experiments on models of varying ship forms; and his son, Mr. R. E. Froude, superintendent of the Admiralty experimental tank at Haslar, has carried on and developed the investigation so far as the pressure of other and more urgent experiments connected with the construction of ships for the Royal Navy has permitted.

The model propellers used by Prof. Durand were forty-nine in number, of 12 inches diameter, with

bosses of uniform diameter (2½ inches); all the models had four blades, and all the blades were elliptical in shape. Blade-areas and pitch-ratios were varied over wide limits, going beyond the range of variation occurring in actual practice. For example, the pitch-ratios tried extended up to 2.1 from 0.9 by differences of 0.2, and the blade-areas were carried down to unusually small proportions of the disc area. Great care was taken to shape the model screws truly and to measure the pitch accurately. For each propeller there was a determination of the power absorbed and the thrust developed for a given number of revolutions per minute, and a corresponding record of the speed of advance in undisturbed water. Practically uniform motion was ensured, and accurate measurements were made of time, distance and force. From these experimental data the actual and comparative efficiencies of the model-screws were ascertained, and the percentages of "slip" could be estimated. The facts are tabulated and graphically illustrated in the memoir. They require and deserve detailed study. In this brief notice it is not possible even to mention the most striking features. Prof. Durand briefly summarises his conclusions in regard to the character of the efficiency-curves of the different model screws, and supplements this section by a description of the method he recommends for applying experimental results to propeller design for actual ships.

One cannot peruse this memoir without regretting that, as yet, no British university, or public institution primarily devoted to scientific work, possesses an experimental tank such as is attached to Cornell University, the University of Michigan, and to the Technical High School at Charlottenburg. Its value for purposes of instruction is great; but its importance as a means of research can hardly be over-estimated. When tanks are closely associated with the detail-work incidental to the design of actual ships, the opportunities for research are less, and the interruptions of research-work more numerous and serious when undertaken in the intervals of ordinary employment. In other words, research has to give way to urgent demands connected with ship-designs, and the special apparatus required for research has to be removed or dismantled at short intervals. This has been the experience at the Admiralty tank, and at the two tanks attached to the shipbuilding yards at Dumbarton and Clydebank. A great need exists, therefore, in this the greatest shipbuilding and ship-owning country in the world, for an experimental tank in which research work on ship-forms and propellers can be undertaken systematically and uninterruptedly. This need has been recognised for a long time. The Institution of Naval Architects has made efforts to interest ship-owners and ship-builders in the establishment of such a tank at the National Physical Laboratory. Considerable support has been obtained from ship-builders and from a few ship-owners, but hitherto it has not been possible to secure the whole amount needed for the construction and equipment of the tank, estimated at 15,000*l.*, or for its maintenance, estimated at 1500*l.* a year. This failure is greatly to be regretted, and is not creditable to the community interested in shipping. It is certain that the investigations made at such an establishment would secure large economies and enable great advances to be made in the construction and propulsion of ships. In connection with screw-propellers alone there is a great opportunity for economies in coal-consumption, the benefits of which would be secured by ship-owners, and the amount of which in a single year's operations of our immense mercantile marine would far exceed the cost of the research-tank. Seeing that the United States and Germany already have a

¹ "Researches on the Performance of the Screw Propeller." By Prof. W. F. Durand. Pp. 61. (Washington: Carnegie Institution, 1907.)

distinct lead in this matter, it may be hoped that the scheme, which has been long delayed, will be realised before long, and the reproach wiped away that the country which equals all the rest of the world in its shipping and shipbuilding lags behind other countries in utilising the experimental methods due to that great English man of science William Froude.

Until recent years work done by the Froudes and published by permission of the Admiralty furnished the best information available for guidance in propeller design, especially when associated with progressive trials of steamships. The experimental methods introduced at Torquay and Haslar were then adopted and extended of late by other workers having command of specially equipped hydraulic laboratories or tanks. Amongst these the Washington tank, belonging to the United States Navy Department, has taken a leading position under the able superintendence of Naval Constructor Taylor, who received his training as a naval architect at the Royal Naval College, Greenwich. In addition to this establishment, the United States has the great advantage of possessing experimental tanks attached to universities; these tanks are necessarily more available for research-work than any establishment can be which is created primarily and regularly employed for experimental work bearing directly on actual ship-construction. Prof. Durand—whose investigations on screw-propellers specially claim attention in this notice—for ten years past has closely studied the screw-propeller problem. His later experiments have been made at the hydraulic laboratory of Cornell University; they are systematic and thorough within the limits of the scheme laid down. The method and results have been admirably described and summarised in a memoir of about sixty pages. The Carnegie Institution of Washington made a grant in aid of the experiments, and has published the memoir, thereby conferring great benefit on all who are concerned in the propulsion of steamships, and furnishing a fresh illustration of the encouragement given to scientific research in the United States.

NOTES.

THE following fifteen candidates have been selected by the council of the Royal Society to be recommended for election as fellows of the society:—Mr. W. Barlow, the Earl of Berkeley, Mr. Dugald Clerk, Prof. A. Dendy, Prof. H. H. Dixon, Mr. J. Stanley Gardiner, Prof. W. Gowland, Mr. J. H. Grace, Prof. D. J. Hamilton, Mr. C. I. Forsyth Major, Mr. E. N. Nevill, Mr. W. H. Rivers, the Hon. Bertrand Russell, Dr. Otto Stapf, and Dr. J. F. Thorpe.

A SPECIAL general meeting of the Geological Society will be held on April 1 to consider a resolution relating to the admission of women to full fellowship of the society.

It is reported by The Hague correspondent of the *Globe* (March 3) that Prof. Kamerlingh Onnes, professor of physics in the University of Leyden, has succeeded in liquefying helium.

SIR OLIVER LODGE will deliver his presidential address to the Faraday Society on Tuesday, March 24. The subject of the address will be "Some Aspects of the Work of Lord Kelvin."

THE Paris correspondent of the *Times* reports that Prince Roland Bonaparte has placed at the disposal of the Academy of Sciences a sum of 100,000 francs (4000*l.*) to be employed in promoting discoveries by facilitating the task of investigators who have already given proof of

their ability by original work, but who may lack the resources necessary for undertaking or pursuing their investigations.

PROF. J. R. BRADFORD, F.R.S., Sir T. H. Holdich, K.C.M.G., and the Duke of Northumberland, F.R.S., have been elected members of the Athenæum Club under the provisions of the rule which empowers the annual election by the committee of nine persons "of distinguished eminence in science, literature, the arts, or for public services."

DR. ARTHUR KEITH, lecturer on anatomy at the London Hospital Medical College, has been appointed conservator of the museum of the Royal College of Surgeons, in succession to the late Prof. C. Stewart.

PROF. MILNE'S discourse at the Royal Institution on "Recent Earthquakes," announced for Friday next, March 6, has been postponed until March 20. The discourse on Friday next will be delivered by Prof. Love on "The Figure and Constitution of the Earth."

IN a footnote to Cowper's poem (Magnēt edition, 1834), a remarkable meteor, August 18, 1783, and a fog which covered Europe and Asia during the summer of 1783 are mentioned, as well as an earthquake in Sicily of unusual severity. A correspondent asks for details of these occurrences, or a reference to records of them.

THE following officers of the Asiatic Society of Bengal have been elected for the ensuing year:—*President*, the Hon. Justice Asutosh Mukhopadhyaya; *vice-presidents*, Dr. T. H. Holland, F.R.S., Dr. G. Thibaut, Mahamahopadhyaya Haraprasad Shastri; *general secretary*, Lieut.-Colonel D. C. Phillott; *treasurer*, Mr. J. A. Chapman.

WE learn from the *Times* that the Russian Government is dispatching a research commission to investigate some recent discoveries of mammoth remains in the Yakutsk province of north-east Siberia. The commission consists of a doctor of zoology, of the Academy of Sciences, the senior curator of the zoological department of the academy, and six junior laboratory students. The expedition, which is expected to be absent for a year or more, is supplied with a grant of 16,000 roubles (1600*l.*).

THE report of the committee appointed by the Treasury to inquire generally into the work now performed at the National Physical Laboratory has been published as a Parliamentary paper (Cd. 3926), which also includes a Treasury minute recording the approval by the Treasury of the recommendations contained in the report of the majority of the committee. The opinion of the 1898 committee, that the work proper for a National Physical Laboratory to undertake should include not only physical research directly or indirectly bearing on industrial problems, and the standardisation and verification of instruments, but also—under proper restrictions—the testing of materials, is in the first place endorsed. The committee then distinguishes "commercial testing" into "contractual" and "investigatory" testing—"contractual" testing being the ordinary testing of materials to ascertain whether their quality and behaviour are in accordance with the requirements of contracts; "investigatory" testing the investigation for commercial purposes of various substances in which no question of contract arises. To place restrictions upon "investigatory" testing would, it is pointed out, hinder the advance of knowledge. The committee thinks that the laboratory should remain entirely free with regard to "investigatory testing," and, as a rule, be debarred from undertaking "contractual testing"—though electrical, thermal, optical, and other physical tests are to

be regarded as exceptional, and such as the laboratory may undertake. In the second place, no restriction should apply, the committee reports, to "reference" testing wherever, in cases of dispute, the parties concerned agree to refer their differences to the authoritative decision of the laboratory, or where the laboratory is called in by a Court of law or of arbitration. Lastly, in view of the character of the laboratory as a public institution, the laboratory is to be free to accept any work which any Government department may desire to commit to it. Subject to these observations, the committee does not consider that any alteration is required in the scope of the work of the National Physical Laboratory as defined by the committee of 1898. In a note added to the report Sir Andrew Noble and Sir J. Wolfe-Barry express the opinion that the restriction recommended in respect of "contractual testing" should come to an end after a definite time—say ten years.

In the report of the Maidstone Museum, Library, and Art Gallery for 1907, attention is directed to the unprecedentedly large number of visitors during the year. It is satisfactory to notice that special attention is being concentrated on the local collection in the Kent county room, for which a special subscription list has been opened.

We have received from Messrs. Cassell and Co., Ltd., the first part of a revised and enlarged edition of Mr. R. Kearton's "British Birds' Nests." It is to be completed in sixteen fortnightly parts at the price of one shilling each. When the beauty and number of the illustrations—inclusive of coloured plates of eggs—are taken into consideration, the new issue is a marvel of cheapness, and should command a large sale.

It is announced in the January issue of the *Emu* that active steps are being taken by the Australian Ornithologists' Union to make more effective the laws for the protection of egrets and birds-of-paradise, groups which are specially persecuted for the sake of their plumage. The union is likewise encouraging lighthouse keepers to record observations with regard to the birds that strike against the lighthouses on the Australasian coasts on migration.

ACCORDING to Mr. T. Southwell's notes in the February *Zoologist*, the Arctic whaling voyage of last year, so far as the prime object of pursuit is concerned, was a disastrous failure. The seven vessels which left Dundee captured, in fact, only three right-whales among them, one being little more than a "sucker," which yielded only half a hundredweight of whalebone. This juvenile was taken in Davis Strait, while the two larger whales were captured in Greenland waters. The two latter yielded 32 cwt. of "bone," the price of which is now about 2400l. per ton. It is noteworthy that during the last two seasons most of the few whales taken were from Greenland waters, where the species was supposed to be practically exterminated.

THE biting flies of India form the subject of Bulletin No. 7 of the Agricultural Research Institute at Pusa. The account, which is drawn up by Mr. H. M. Lefroy, the Government entomologist, is intended to pave the way for a full investigation into the natural history of these insects, and has been published to a great extent with the view of stimulating the collection of specimens all over the country. If such collection be carried out systematically, there is little doubt that a number of new species will be brought to light, especially among groups like the

sand-flies, represented by species of minute size. The Bulletin contains two coloured plates of horse-flies and cattle-flies, with, in some instances, their larvæ and eggs as an aid to the identification of species.

WE have received copies of four papers recently issued by the Entomological Bureau of the U.S. Department of Agriculture. The first of these, by Dr. W. E. Hinds, is devoted to further investigations with regard to the capability of natural agencies for holding in check the ravages of the pernicious cotton-boll weevil. On the whole, a hopeful view of the matter is entertained. The factors in question are conditions of temperature and moisture, predaceous and parasitic foes, and food-supply. While it may be impossible to increase the effectiveness of these agencies, there is reason to believe that others may be caused to lessen materially the weevil's power of mischief. A second paper treats of the ravages of the caterpillars of the catalpa hawk-moth (*Ceratomia catalpæ*) on catalpa trees, which are sometimes completely stripped of their foliage. The two remaining papers deal respectively with the lesser apple-worm and wax-moths in connection with bee-keeping. In the case of the latter it is shown that the idea that the larvæ of wax-moths are beneficial to bee-keepers is erroneous.

A REPORT on marking and transplantation experiments with plaice in Danish waters, by Mr. A. C. Johansen, has recently been issued by the Danish Commission for the Study of the Sea (*Medd. Kommis. for Havundersøgelser. Ser. Fiskeri, Bd. ii., No. 5*). The report contains an account of experiments made by the Danish Government in connection with the international fishery investigations. It is shown that the rate of growth of plaice varies in different districts, a result which confirms the conclusions which have been arrived at by English fishery investigators. Considerable light is also thrown by the experiments on the migration of plaice in Danish waters. Much importance is attached by Johansen to the facts that in the experiments in the Horns Reef area the value of the recovered specimens surpasses the value of all the liberated ones, and that in the Kattegat experiments the size at which the value of all the recovered specimens is equal to the value of all the liberated ones is higher than the present Danish size limit for Kattegat plaice (ca. 25.6 cm.) From the latter result it is suggested that a size limit for plaice in the Kattegat somewhat higher than that now enforced by Denmark might be considered by the international authorities with advantage.

MR. S. YAMANOUCHI contributes to the *Botanical Gazette* (January) an account of sporogenesis in the fern genus *Nephrodium*, dealing with nuclear changes in *Nephrodium molle*. The author comes to the conclusion that in the normal life-history of the genus there is a reduction of chromosomes in sporogenesis, and that the first nucleus which contains the reduced number of sixty-four or sixty-six chromosomes is the spore; further, that the first division of the spore is heterotypic, but the reduction is only completed in the second homotypic division.

THE economic value of the sunflower plant as a source of oil yielded by the seeds not infrequently forms the subject of inquiry. From the account of the plant that is provided by Mr. D. Hooper in the *Agricultural Ledger* (No. 1, 1907), issued by the Government of India, it is evident that as a crop it offers little inducement to planters except in southern Russia—possibly also in China—where there is a local consumption of the kernels roasted or salted, and the oil is in request for culinary or edible

papers. The pamphlet contains information with regard to experimental cultivation in India and the United States of America.

An article communicated by the chief conservator of forests in Burma, Mr. F. B. Bryant, is published in the *Indian Forester* (December, 1907), in which a strong case is made out against continued fire conservancy in certain of the moist teak forests. The policy of fire conservancy continued over a period of years has resulted in excessive development of the bamboos *Bambusa polymorpha* and *Cephalostachyum pergracile*, which smother the young teak and other light-demanding trees. It is also pointed out that, owing to the presence of the latter bamboo, extensive regeneration of teak when the *Bambusa* flowers gregariously is likely to be frustrated. The sanction of the Government of Burma to the abandonment of fire conservancy in selected areas has already been granted.

An important article on the Douglas fir as a commercial timber tree is contributed to the Transactions of the Royal Scottish Arboricultural Society (vol. xx., part 1.) by Mr. J. D. Crozier. Owing to the difference in the rate of growth, it is essential to distinguish between the "green" Oregon variety and the slower growing "glaucous" Colorado variety. The author alludes to the excellent results shown by pure plantations on the Grampians, but expresses the opinion that the Douglas fir is not adapted to mixed plantations unless with the Norway spruce. As a suitable crop for poor and exposed ground, Sir John Stirling-Maxwell recommends the mountain pine, *Pinus montana*. Three varieties are specified, the upright, the intermediate, and the dwarf forms. The first is the more valuable, and grows at high elevations, notably in the Pyrenees. The intermediate is principally useful for afforestation of heaths; the dwarf form has no sylvicultural interest.

The Director-General of Indian Observatories has issued a memorandum (dated December 6, 1907) on the meteorology of October and November, 1907, with a discussion of the conditions affecting the precipitation during the cold weather of 1907-8. These seasonal forecasts, although at present only general opinions based on past experience, are of very great importance both to the Government and to agriculturists. On the mean of the whole country, the rainfall in October was 52 per cent. and in November 31 per cent. in defect. The records of the last thirty years, including some selected from places outside India, show that conditions like those of the past season have been followed by a deficiency of precipitation in January more often than by an excess. The data then available for February throw very little light upon the probable rainfall of that month.

A TOUCH of wintry weather has spread over the whole country during the past week, and somewhat heavy falls of snow have occurred over a large part of Great Britain, whilst the temperature has been lower than for some time past. Strong winds and gales have been experienced in many places, and since March set in our weather has been under the influence of cyclonic disturbances passing down the North Sea. The Summary of the Weather issued by the Meteorological Office shows that for the winter season—December to February—the mean temperature over the United Kingdom was nowhere very different from the average. The heaviest rainfall for the three months occurred in the north of Scotland, where the aggregate measurement was 17.19 inches, whilst the least aggregate fall was 5.21 inches, in the north-east of England. The

winter rainfall was generally in excess of the average over the northern portion of the kingdom, but in defect elsewhere. The greatest excess was 1.61 inches, in the north-west of England, whilst the greatest deficiency was 2.65 inches, at the English Channel stations. The number of days with rain ranged from seventy-one in the north of Scotland to forty-seven in the south of England and the Midland counties. The greatest duration of sunshine for the winter was 203 hours, in the Midland counties, which is twenty-nine hours more than the average. The least duration was ninety-five hours, in the north of Scotland.

At the instance of Prof. Ricchieri, of the Accademia Scientifico-Letteraria, Milan, the reader of a paper on the spelling of place names at the sixth International Geographical Congress, held at London in 1895, the organising committee of the ninth International Geographical Congress, which is to meet at Geneva on July 27 to August 6, has placed on the list of agenda of the congress the following question:—What are the principal difficulties in the way of arriving at an international agreement on the transcription and orthography of geographical names, and in what manner can they be surmounted? Prof. Ricchieri, believing that if this problem is to be solved at all it can only be by slow stages and methodical procedure, proposes that all that should be aimed at in the first instance should be a preliminary understanding among a few men of different nationalities interested in this question as to the fundamental points on which it is necessary that a final agreement should, if possible, be reached, and that a statement of those points should be laid before the congress at Geneva, which should then be asked to appoint a small committee to study and procure the discussion of those points, and ultimately to draw up proposals and resolutions thereon. He further suggests that this committee should be expected to publish its proposals at least one year before the meeting of the next International Congress, which, it is hoped, might then be in a position to draw up final resolutions on the subject. This scheme of operations has received the support of Prof. Henri Cordier, of the École spéciale des langues orientales, Paris; Prof. Robert Sieger, of the University of Graz; and of Mr. G. G. Chisholm, Birkbeck College, University of London, who have agreed to cooperate with Prof. Ricchieri in drawing up the preliminary statement of fundamental points requiring solution to be laid before the Geneva congress. Mr. Chisholm will be glad to forward to Prof. Ricchieri any suggestions on this question sent to him at his private address (59 Drakefield Road, Upper Tooting, London, S.W.).

THE curious phenomenon of a soft steel disc revolving at a high speed cutting hard steel has attracted the attention of numerous observers, and Mr. F. W. Harbord has endeavoured to throw light on the subject by publishing in the *Engineer* of February 21 the results of a microscopic examination of the revolving disc and of the material subjected to its action. He finds that the material acted upon is heated at the point of contact to a temperature approaching, if not equal to, the melting point of steel, and that this high temperature is confined practically to the surface in contact with the disc.

In the *Engineering Magazine* (vol. xxxiv., No. 5) attention is directed by Mr. Clarence Hall and Mr. W. O. Snelling to the waste of life in American coal-mining. Four recent mine disasters in the United States, with the loss of nearly one thousand lives, emphasise the urgent importance of the theme. Statistics show in regard to

deaths per million tons of coal that the United States not only occupies a position worse than that of European countries, but also exhibits a general increase in the rate, whereas every other country has shown a decrease. The situation is still worse when it is considered that the natural conditions in America for raising coal with the minimum amount of danger to the workmen employed are as favourable as in any other country in the world. The natural result of the working of the thinner and less favourably mined seams will be greatly to increase the death-rate unless regulations based on careful investigations are rigidly enforced.

EGYPT furnishes a region of great scientific interest which is as yet almost unexplored in many branches of knowledge, and it often happens that observations which seem commonplace to those resident in the country are of great value to workers elsewhere. The success which attended the periodical *Survey Notes* during the fifteen months it has been in existence has suggested that its scope might be extended with advantage, and with that object it has been decided to include communications on all branches of science. The magazine, which will in future be entitled the *Cairo Scientific Journal*, makes, in its January issue, a good start. The principal contents are papers on an expedition to Addis Abbaba, by Mr. J. I. Craig; on the underground waters of Egypt, by Mr. H. W. Beckett; on the use of the slide-rule in surveying, by Dr. J. Ball; on azimuth checks on traverse work, by Mr. M. Villiers Stuart; on upper air research at Helwan, by Mr. B. F. E. Keeling; and on temperature and constructional stability, by Mr. J. I. Craig.

On February 18 Mr. J. J. Prest read before the Institution of Civil Engineers a paper describing a remarkable achievement in mining engineering, the shaft sinking at the Horden colliery, south-east Durham. The work was of exceptional difficulty owing to the large volumes of water encountered in sinking through the magnesian limestone and sands of Permian age. In view of possible legislative interference with the hours of underground labour, it was decided to sink three shafts, two 20 feet and one 17 feet in finished diameter. The north shaft was begun on November 6, 1900, and was finished at a depth of 419 yards on July 23, 1904. The south shaft was begun on February 28, 1901, and was finished at a depth of 302 yards on September 1, 1905. The east shaft, 17 feet in diameter, was begun on September 3, 1900, and was finished at a depth of 406 yards on November 6, 1905. The maximum feeders of water pumped simultaneously at any one period amounted to 9230 gallons per minute, from the east and south shafts, from September 23 to November 26, 1903. The production of coal from this colliery is now averaging a million tons per annum.

The annual report of the council of the Institution of Mechanical Engineers, presented at the annual meeting of members on February 21, summarises the progress and work of the institution during the past year. The council has accepted from Mr. Charles Hawksley an offer of rool. for the foundation of a scholarship or premium in connection with the institution, to commemorate the centenary of the birth of his father, Mr. Thomas Hawksley, past-president. In connection with the alloys research committee it is noted that sea-water corrosion tests on copper-aluminium alloys are being carried out at Portsmouth Dockyard by the National Physical Laboratory. A systematic investigation of the ternary alloys of copper and aluminium with other metals, in the first place with

manganese, zinc, and nickel, has been begun, and the preliminary investigation of the copper-aluminium manganese alloys is approaching completion. The council has made a small grant to Dr. H. C. H. Carpenter to investigate at the Manchester University the conditions which have to be observed if metal castings are to be capable of being gas-tight and steam-tight. Some further experiments on the large gas engine at the University of Birmingham are to be carried out by Prof. F. W. Burstall with a water-brake and with both optical and string indicators. The research committee on the value of the steam-jacket has met twice during the year, and designs are being prepared by Prof. T. Hudson Beare for carrying out jacket experiments with a larger apparatus than that formerly used by the committee. Information on the present state of knowledge on the following subjects is also being collected, previous to the appointment of research committees for prosecuting further inquiries:— (1) the features of refrigerating machinery in which further investigation is needed; (2) the transfer of heat across metallic surfaces in contact with water and with gases; (3) the action of steam passing through nozzles and steam turbines.

THE *Physikalische Zeitschrift* for February 15 contains an account of Dr. H. W. Schmidt's experiments on the effect of high temperatures on the disintegration of radium C. The work was undertaken to decide between the conclusion of Messrs. Makower and Russ, that high temperature diminished temporarily the activity of radium, and that of Mr. Bronson, who denied the existence of such an effect. Dr. Schmidt's experiments were made on radium C prepared by von Lerch's method. The preparation was enclosed in a quartz tube which could be heated to 1300° C. in an electric furnace. The activity was measured by the fall of the leaves of a gold-leaf electroscope placed close to the furnace. The author concludes that at 1300° C. the preparation behaves exactly as at ordinary temperatures.

THE theory of the radiation of the Auer incandescent gas mantle is discussed by M. M. Foix in the February number of the *Journal de Physique*. It is generally admitted that the mantle owes its brilliance to its selective radiation, which appears, according to the researches of Prof. Rubens, to be brought about by the addition of a little oxide of cerium to oxide of thorium. M. Foix now comes to the conclusion that the luminous efficiency of the mantle can be increased by carrying the dilution of the oxide of cerium in the oxide of thorium a further stage, the result being brought about by the diminution of the infra-red radiation of the mantle and a consequent increase of its temperature. The best proportion of the oxides appears to be 1 of cerium to 100 of thorium.

THE attention of those of our readers who practise photography is directed to the catalogue of photographic dry plates, filters, and safelight screens recently issued by Messrs. Wratten and Wainwright, Ltd., of Croydon. The particulars provided are practical in character, and the tables of sizes and prices conveniently arranged.

THE March issue of the *National Review* opens a new series, printed in larger type and provided with a different cover. Among its varied contents we notice an appreciation of the late Lord Kelvin by Sir William Ramsay, K.C.B., F.R.S., in which a delightful picture of Kelvin as a teacher is drawn, and a popular account given of some of his contributions to natural knowledge.

MESSRS. JOHN J. GRIFFIN AND SONS, LTD., have issued an illustrated and descriptive catalogue of apparatus suitable for demonstration purposes in the teaching of physiography, physiology, and hygiene. The information included respecting globes and lantern-slides should be particularly useful to teachers of geography who follow modern methods of presenting their subject.

A SECOND edition of Prof. G. S. Boulger's "Wood: a Manual of the Natural History and Industrial Applications of the Timbers of Commerce," has been published by Mr. Edward Arnold. The first edition was reviewed in NATURE of January 15, 1903 (vol. lxxvii., p. 245), and it will be sufficient here to say the work has been revised and enlarged, and that its price is now 12s. 6d. net.

THE National Home-Reading Union, with the cooperation of the Library Association, has arranged to publish a penny monthly magazine for the guidance of readers in public libraries in the choice of books and other reading. The first issue, that for February, is now available, and among its principal contents may be noticed articles by Prof. H. H. Turner, F.R.S., on books about astronomy; books about Australia, by Sir John Cockburn, K.C.M.G.; and the literature of the sea, by Mr. Frank T. Bullen. The *Reader's Review*, as the guide is called, is intended primarily for localisation in the various libraries by means of the insertion of additional pages containing local literary notes, lists of recent additions, and so on. The idea of assisting readers in their choice of books is excellent, and it is to be hoped that the efforts of the editorial board will prove successful. The paper is published by Messrs. Sherratt and Hughes.

OUR ASTRONOMICAL COLUMN.

ASTRONOMICAL OCCURRENCES IN MARCH:—

- March 5. 1h. Venus in conjunction with Moon. Venus 5° 49' N.
- 8h. 59m. Minimum of Algol (β Persei).
- 6. 3h. Mars in conjunction with Moon. Mars 5° 26' N.
- 8. 10h. 10m. to 10h. 32m. Moon occults δ² Tauri (Mag. 4.2).
- 9. 11h. 42m. to 10h. 31m. Transit of Jupiter's Satellite IV. (Callisto).
- 10. Pallas (Mag. 8.04) in opposition to the Sun.
- 12. 6h. 12m. to 9h. 54m. Transit of Jupiter's Satellite III. (Ganymede).
- 13. 4h. Jupiter in conjunction with Moon. Jupiter 1° 7' S.
- 19. 9h. 47m. to 13h. 28m. Transit of Jupiter's Satellite III. (Ganymede).
- 20. 12h. Sun enters Aries, Spring commences.
- 21. Venus. Illuminated portion of disc = 0.677.
- 26. 22h. Mercury at maximum elongation West (27° 49').
- 28. 7h. 30m. Minimum of Algol (β Persei).
- 31. Ceres (Mag. 7.36) in opposition to the Sun.

MICROMETER OBSERVATIONS OF PHEBE.—During the period July 24 to October 16, 1906, Prof. Barnard made a number of observations of Phœbe, Saturn's tenth satellite, of which he now publishes the results in No. 4234 of the *Astronomische Nachrichten* (p. 145, February 22). A variation of brightness, amounting to half a magnitude or more, is indicated by the fact that while the object was usually a difficult one, of magnitude 16.0 or 16.5, it was found to be comparatively easy during October, and was perhaps brighter than the sixteenth magnitude. On several occasions the satellite presented a hazy appearance, and Prof. Barnard suggests that, should future observations

confirm this nebulous or cometary character, the solution of the question of Phœbe's origin in the Saturnian system will be simplified.

EPHEMERIS FOR DANIEL'S COMET, 1907d.—The following is an extract from Herr Kritzinger's ephemeris for comet 1907d, published in No. 4234 (p. 159, February 22) of the *Astronomische Nachrichten*:—

Ephemeris 12h. (Berlin M.T.).

1908	a (1908 ^h) h. m.	δ (1908 ^o) ° ' "	1908	a (1908 ^o) h. m.	δ (1908 ^o) ° ' "
Mar. 5 ...	15 4' 4 ...	-6 44' 0 ...	Mar. 21 ...	14 53' 0 ...	-5 6' 9 ...
„ 13 ...	14 59' 7 ...	-5 57' 0 ...	„ 29 ...	14 46' 5 ...	-4 15' 5 ...

The computed magnitude of this object is 10.6, and the comet is now apparently travelling eastwards through the constellation Libra towards Virgo, rising a little south of east at about 10.30 p.m. On March 17 it will be about 2½° north of δ Libræ.

THE SPECTRUM OF THE AURORA BOREALIS.—An exhaustive summary and discussion of the contents hitherto obtained from spectroscopic observations of the aurora appears in No. 9, vol. xxxv. (September, 1907), of the *Monthly Weather Review* (U.S. Weather Bureau), from the pen of Dr. W. Marshall Watts. All the recorded visual and photographic observations made since the time of Ångström's observations in 1867 are analysed and compared, and the most probable values for the wave-lengths of the principal lines are tabulated; for the chief green line this value is 5571.6, and for the red line 6303.4. Various observations suggest that the spectrum varies at different times, and Dr. Watts urges that far more numerous and continuous observations should be made. With the apparatus which he describes, such observations could be made at a very small cost by any qualified observer.

SUN-SPOT SPECTRA.—No. 1, vol. xxvii., of the *Astro-physical Journal* (January) contains two papers which should prove of interest to all workers in solar physics. The first of these is by Prof. W. S. Adams, and really consists of a preliminary catalogue of lines affected in sun-spots. The photographs on which these lines were detected were taken with a Littrow spectrograph, used in conjunction with the Snow telescope of the Mount Wilson Solar Observatory, and give a linear dispersion of 1 mm.=1.5 Å. The present catalogue includes a list of the lines affected in sun-spots in the region A 4000 to A 4500, and is to be followed by other lists giving the results obtained in other parts of the spectrum. The lines, their behaviour, and their origins are not discussed now, the discussion being reserved until the catalogue is complete; the present list includes nearly 900 lines, for each of which the probable origin, the intensities in Rowland's table and in the spot, together with remarks on its behaviour in the spot, are given.

In the second paper Mr. Charles M. Olmsted, of the Mount Wilson Observatory, announces that he has succeeded in identifying certain bands in the sun-spot spectrum with similar bands in the spectrum of the calcium arc burning in an atmosphere of hydrogen. There are two main groups of these bands, the stronger one at A 6385, the weaker running through the B group, and the comparison with the spot spectrum leaves no doubt as to their identity.

ASTRONOMY IN WALES.—The *Cambrian Natural Observer* (January) contains several papers on astronomical subjects read before the Astronomical Society of Wales last year. Among others may be mentioned a paper by Mr. T. E. Heath on star clouds and nebulae, another dealing with transits past and present, and an abstract of a paper by the Rev. John Griffith on the astronomy of the stones, delivered in November last before a crowded meeting of the Cardiff Archaeological Society and the Astronomical Society in Wales. Sir Norman Lockyer's method of investigation of stone monuments was explained, and the audience was urged to aid in the accumulation of the orientation data which is apparently so abundant in Wales.

The periodical is again to be issued as a quarterly.

RECENT ADVANCES IN RADIO-ACTIVITY.¹

IN 1904 I had the honour of giving an address at the Royal Institution on the subject of radio-activity. In the interval steady and rapid progress has been made in unravelling the tangled skein of radio-active phenomena. In the present lecture I shall endeavour to review very shortly some of the more important advances made in the last few years, but as I cannot hope to mention, even briefly, the whole additions to our knowledge in the various branches of the subject, I shall confine my attention to a few of the more salient facts in the development of which I have taken some small share.

In my previous lecture I based the explanation of radio-active phenomena on the disintegration theory put forward in 1903 by Rutherford and Soddy, which supposes that the atoms of the radio-active bodies are unstable systems which break up with explosive violence. This theory has stood the test of time, and has been invaluable in guiding the experimenter through the maze of radio-active complications. In its simplest form, the theory supposes that every second a certain fraction (usually very small) of the atoms present become unstable and explode with great violence, expelling in many cases a small portion of the disrupted atom at a high speed. The residue of the atom forms a new atomic system of less atomic weight, and possessing physical and chemical properties which markedly distinguish it from the parent atom. The atoms composing the new substance formed by the disintegration of the parent matter are also unstable, and break up in turn. The process of degradation of the atom, once started, proceeds through a number of distinct stages. These new products formed by the successive disintegrations of the parent matter are in most cases present in such extremely minute quantity that they cannot be investigated by ordinary chemical methods. The radiations from these substances, however, afford a very delicate method of qualitative and quantitative analysis, so that we can obtain some idea of the physical and chemical properties of substances existing in an amount which is far below the limit of detection of the balance or spectroscopically.

The law that governs the breaking up of atoms is very simple and universal in its application. For any simple substance, the average number of atoms breaking up per second is proportional at any time to the number present. In consequence, the amount of radio-active matter decreases in a geometrical progression with the time. The "period" of any radio-active product, *i.e.*, the time for half the matter to be transformed, is a definite and characteristic property of the product which is uninfluenced by any of the laboratory agents at our command. In fact, the period of any radio-active product, for example, the radium emanation, if determined with sufficient accuracy, might well be taken as a definite standard of time, independent of all terrestrial influences.

The law of radio-active transformation can be very simply and aptly illustrated by an hydraulic analogy. Suppose we take a vertical cylinder filled with water, with an opening near the base through which the water escapes through a high resistance.² When the discharge is started the amount of water escaping per second is proportional to the height of water above the zero level of the cylinder. The height of water decreases in a geometrical progression with the time in exactly the same way as the amount of radio-active matter decreases. We can consequently take the height of the column of water as representing the amount of radio-active matter A present at any time. The quantity of water escaping per second is a measure of the rate of disintegration of A and also of the amount of the new substance B formed per second by the disintegration of A. The "period" of the substance is controlled by the amount of resistance in the discharge circuit. A high resistance gives a small flow of water and a long period of transformation, and *vice versa*. By a suitable arrangement we can readily trace out the decay curve for such a case. A cork carrying a light vertical glass rod is floated on the water in the cylinder. A light camel's hair brush

is attached at right angles, and moves over the surface of a smoked-glass plate. A vertical line drawn on the glass through the point of contact of the brush gives the axis of ordinates, while a horizontal line drawn through the brush when the water has reached its lowest level gives the axis of abscissae. If the glass plate is moved with uniform velocity from the moment of starting the discharge a curve is traced on the glass which is identical in shape with the curve of decay of a radio-active product, where the ordinates at any time represent the relative amount of active matter present, and the abscissae time. With such an apparatus we can illustrate in a simple way the increase with time of radio-active matter B, which is supplied by the transformation of a substance A. This will correspond, for example, to the growth of the radium emanation with time in a quantity of radium initially freed from emanation. Let us for convenience suppose that A has a much longer period than B. In the hydraulic analogy A is represented by a high head of water discharging at its base through a circuit of high resistance into the top of another cylinder representing the matter B. The water from the cylinder B escapes at its base through a lower resistance. Suppose that initially only A is present. In this case the water in the cylinder B stands at zero level. On opening the stop-cock connecting with A, water flows into B. The rise of water with time in the cylinder B is traced out in the same way as before by moving the glass plate at a constant rate across the tracing brush. If the period of A is very long compared with that of B the water is supplied to B at a constant rate, and the water in B reaches a constant maximum height when the rate of supply to B equals the rate of escape from the latter. The curve traced out in that case is identical in shape with the "recovery curve" of a radio-active product supplied at a nearly constant rate. The quantity of matter reaches a maximum when the rate of supply equals its own rate of transformation. The relative height of the columns of water in A and B represents at any time the relative amounts of these substances present.

If the period is comparable with that of B, the height of water in B after reaching a maximum falls again, since as the height of A diminishes the supply to B decreases. Ultimately, the height of B will decrease in a geometrical progression with the time at a rate corresponding to the longer period of the two. This is an exact illustration of the way the amount of a radio-active substance B varies when initially only the parent substance A is present. By using a number of cylinders in series, each with a suitable resistance, we can in a similar way illustrate in a quantitative manner the variation in amount with time of a number of products arising from successive disintegrations of a primary substance. By suitably adjusting the amount of resistance in the discharge circuits of the various cylinders, the curves could be drawn to scale to imitate approximately the variation in amount of the various products with time when the initial conditions are given.

During the last few years a very large amount of work has been done in tracing the remarkable succession of transformations that occur in the various radio-active substances. The known products of radium, thorium, actinium, and uranium are shown graphically below, together with the periods of the products and the character of the radiations they emit. It will be seen that a large list of these unstable bodies are now known. It is probable, however, that not many more remain to be discovered. The main uncertainty lies in the possibility of overlooking a product of rapid transformation following or succeeding one with a very slow period. In tracing out the succession of changes, the emanations or radio-active gases continuously evolved by radium, thorium, and actinium have marked a very definite and important stage, for these emanations can be easily removed from the radio-active body and their further transformations studied quite apart from the parent element. The analysis of the transformation of the radium emanation has yielded results of great importance and interest. After passing through three stages, radium A, B, and C, of short period, a substance, radium D, of long period, makes its appearance. This is transformed through two stages E and F of short period into radium G, of period 140 days. Meyer and Schweidler have conclusively shown that radium D is the primary

¹ A discourse delivered at the Royal Institution on Friday, January 31, by Prof. E. Rutherford, F.R.S.

² A short glass tube in which is placed a plug of glass wool is very suitable.

constituent of the radio-active substance separated by Hofmann and called by him radio-lead. Radium G is identical with the first radio-active substance separated from pitchblende by Madame Curie, viz. polonium. We are thus sure that these bodies are transformation products of radium. It will be seen that I have added another product of period 4.5 days between Radium D and polonium. The presence of such a product has been shown by Meyer and Schwedler.

In the case of thorium, a very long list of products is now known. For several years thorium X was thought to be the first product of thorium, but Hahn has recently shown that at least two other products of slow transformation intervene, which he has called mesothorium and radiothorium. The radiothorium emits α rays, and has a period of more than 800 days. Mesothorium apparently emits β rays, and has a still longer period of transformation, the exact value of which has not yet been accurately determined. Since thorium is used commercially on a large scale, there is every prospect that we shall soon be able to obtain considerable quantities of very active preparations of mesothorium and radiothorium. The separation of these

however many unknown products intervene, the ratio between the amount of radium and uranium in old minerals should be a definite constant. This is obviously the case, provided sufficient time has elapsed for the amount of radium to have reached its equilibrium value. The constancy of this relation has been completely substantiated by the independent work of Boltwood, Strutt, and McCoy. It has been shown that the quantity of radium corresponding to 1 gram of uranium is 3.8×10^{-7} gram, and is the same for minerals obtained from all parts of the world. Since the radium is always distributed throughout the mass of uranium, we cannot expect to find nuggets of radium like nuggets of gold, unless by some chance the radium has been dissolved out of radio-active minerals and re-deposited within the last few thousands of years. To those who had faith in the disintegration theory, this unique constant relation between the amounts of two elements was a satisfactory proof that radium stood in a genetic relation with uranium. A search was then made for the unknown intervening product which, if isolated, must grow radium at a rapid rate. A year or so ago Boltwood observed that a preparation of actinium separated

bodies from thorium does not in any way alter its commercial value. It is to be hoped that if these active preparations are separated in quantity, the physicist and chemist may be able to obtain a supply of very active material at a reasonable cost, and that there will not be an attempt to compete with the ridiculously high prices charged for radium.

From the radio-active point of view, the radio-elements are only distinguished from their families of products by their comparatively long period of transformation. Now we have reason to believe that radium itself is transformed according to the laws of other radio-active products with a period of about 2000 years. If this be the case, in order to keep up its supply in a mineral, radium must be produced from another substance of relatively long period of transformation. The search for this elusive parent of radium has been one of almost dramatic interest, and illustrates the great importance of the theory as a guide to the experimenter. The view that radium was a substance in continuous transformation was put forward by Rutherford and Soddy in 1903. The most probable parent of radium appeared to be uranium, which has a period of transformation of the order of 1000 million years. If this were the case, uranium, initially freed from radium, should in the course of time grow radium, i.e. radium should again appear in the uranium. This has been tested independently by Soddy and Boltwood, and both have shown that in carefully prepared uranium solutions there is no appreciable growth of radium in the course of several years. The rate of production of radium, if it occurs at all, is certainly less than 1/1000 of the amount to be expected from theory. This would appear at first sight to put out of count the view that uranium is the parent of radium. This, however, is by no means the case, for such a result could be very easily explained if one or more substances of very slow period of transformation appeared between uranium and radium. It is obvious that the necessity of forming such an intermediate product would greatly lengthen the time required before an appreciable amount of radium appeared.

There is, however, another indirect but very simple method of attack to settle the parentage of radium. If radium is derived from the transformation of uranium,

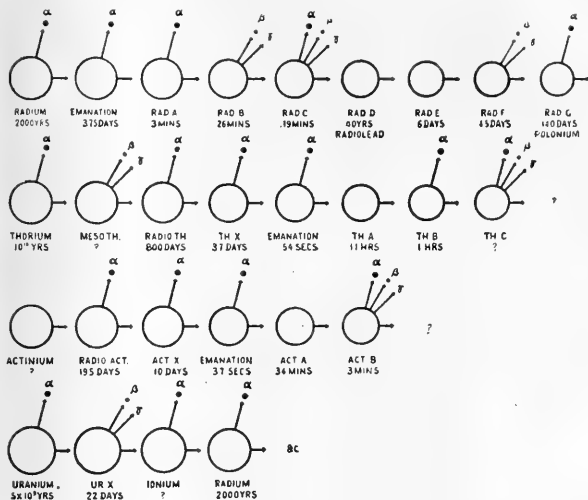

Succession of Substances produced by the transformation of radium, thorium, actinium, and uranium. The period of transformation of each substance is added below.

from a uranium mineral did grow radium at a constant but rapid rate. It thus appeared as if actinium were the long-looked-for parent of radium, and that actinium and its long family of products intervened between uranium X and radium. I was, however, able to show that actinium itself was not responsible for the growth of radium, but another unknown substance separated with it. These results were confirmed by Boltwood, who finally succeeded in isolating a new substance from uranium minerals, which was slowly transformed into radium. This substance, which he termed "ionium," has apparently chemical properties similar to those of thorium, and emits α rays of penetrating power less than those of uranium.

The main provisions of the theory have thus been experimentally verified. Radium is a changing substance the amount of which is kept up by the disintegration of another element, ionium. In order to complete the chain of evidence, we require to show that uranium grows ionium, and it is probable that evidence in this direction will soon be forthcoming. We thus see that we are able to link uranium, ionium, radium, and its long line of descendants, into one family, with uranium as its first parent. As uranium has a period of transformation of

more than one thousand million years, it will not be profitable at the moment to try and trace back the family further.

It appears almost certain that, from the radio-active point of view, uranium and thorium must be considered as two independent elements. The case of actinium is different, for Boltwood has shown that the amount of actinium in minerals, like the amount of radium, is proportional to the amount of uranium. This indicates that actinium stands in a genetic relation with uranium. Unless our experimental evidence is at fault, it does not appear probable that actinium belongs to the main line of descent of uranium, for the activity of actinium separated from a mineral compared with radium is only about one-quarter of what we should expect under such conditions. I think that a suggestion which I put forward some time ago may account for the obvious connection of actinium with uranium, and at the same time for the anomaly observed. This supposes that actinium is a branch descent from some member of the uranium family. It does not appear improbable that at one stage of the disintegration two distinct substances may be produced, one in greater quantity than the other. After the expulsion of an α particle, it may happen that there are two possible arrangements of temporary stability of the residual atom. The great majority of the atoms may fall into one arrangement, and the remainder into the other. Actinium in this case would correspond to the substance in lesser quantity. It would act as a distinct element, and would break up in a different way from the main amount. It is probable that a large amount of accurate work will be required before the position of actinium in the scheme of changes can be fixed with certainty. It is a matter of remark how closely actinium resembles thorium in its series of transformations. It would appear that the atom of actinium has many points in common with thorium, or rather with its product, mesothorium.

The recent observations on the growth of radium offer a very simple and straightforward method of determining experimentally the period of radium. Suppose that we take a uranium mineral and determine by the emanation method the quantity of radium contained in it. If the immediate parent of radium (*i.e.* ionium) is next completely separated from the uranium and radium, it will begin to grow radium at a constant rate. Now the rate of growth of radium observed is a measure of the rate of breaking up of the radium parent in the mineral, since before separation the rate of production was equal to the rate of breaking up. Now the growth of radium observed for a short interval, for example, a year, divided by the quantity present in the mineral, gives the fraction of the radium breaking up per year. Proceeding in this way, Boltwood found that the fraction breaking up per year is about $1/3000$, and that the period of radium is about 2000 years—a value which lies between the most probable values deduced from quite distinct data.

From an inspection of the radio-active families, it will be seen that out of twenty-six radio-active substances that have been identified, seventeen give out α rays or α and β rays, four give out only β rays, and five emit no rays at all. The rayless and β -ray products are transformed according to the same law as the α -ray products, and there is the same sudden change of physical and chemical properties as the result of the transformation. In the case of the substances which throw off atoms of matter in the form of α particles, there are obvious reasons for anticipating a change in properties of the substance, but this is not the case for the rayless or β -ray products. We must either suppose that the mass of the atom is not appreciably changed by the transformation, which consists in an internal rearrangement of the parts of the atom, or that the atom expels a particle at too low a velocity to be appreciated by the electrical methods. Unfortunately, it is very difficult to study the rayless products with care, as in practically every case they are succeeded by a ray product of comparatively rapid transformation. The rayless products are of great interest as indicating the possibility of transformations which can occur without any detectable radiation.

In the course of the analysis of radio-active changes, special methods have been developed for the separation of

the various products from each other. It is only in a few cases, however, that we can hope to obtain a sufficient quantity of the substance to examine by means of the balance. It should be possible to obtain workable quantities of actinium, radium D (radio-lead), and radium G (polonium), but the isolation of these substances in any quantity has not yet been effected. Sir William Ramsay and Mr. Cameron have made a number of important investigations of the properties and volume of the radium emanation, freed so far as possible from any traces of known gases. The remarkable initial contraction of the volume due to the emanation shows that there is still much to be done to obtain a clear understanding of the behaviour of this intensely radio-active gas when obtained in a pure state.

Simultaneously with the work on the analysis of radio-active changes, a large number of investigations have been made on the laws of absorption by matter of the three primary types of radiation from active matter, *viz.* the α , β , and γ rays, and the secondary radiations to which they give rise. It has generally been accepted for some years that the γ rays are a type of penetrating X-rays. The latter are supposed to consist of electromagnetic pulses in the ether, set up by the impact or escape of electrons from matter, and akin in many respects to very short waves of ultra-violet light. Recently, however, Bragg has challenged this view, and has suggested that the γ rays (and probably also the X-rays) are mainly corpuscular in character, and consist of uncharged particles or "neutral pairs," as he terms them, projected at a high velocity. Such a view serves to explain most of the experimental observations equally well as the pulse theory; Bragg has recently brought forward additional evidence, based on the direction of the secondary radiation from the γ rays, which he considers to be inexplicable by the pulse theory. We must await further data before this important question can be settled definitely, but the theory of Bragg, which carries many important consequences in its train, certainly deserves very careful examination.

From the radio-active point of view, the α rays are by far the most important type of radiation emitted by active matter, although their power of penetration is insignificant compared with the β or γ rays. They consist of veritable atoms of matter projected at a speed, on an average, of 6000 miles per second. It is the great energy of motion of these swiftly expelled masses that gives rise to the heating effect of radium. In addition, they are responsible for the greater part of the ionisation observed near an uncovered radio-active substance. On account of their importance in radio-active phenomena, I shall devote some little attention to the behaviour of these rays. The work of Bragg and Kleeman, of Adelaide, first gave us a clear idea of the nature of the absorption of these rays by matter. The α particles from a very thin film of any simple kind of radio-active matter are all projected at an identical speed, and lose their power of ionising the gas or of producing phosphorescence or photographic action after they have traversed exactly the same distance, which may conveniently be called the "range" of the α particle. Now every product emits α particles at an identical speed among themselves, but different from every other product. For example, the swiftest α particles from the radium family, *viz.* that from radium C, travels 7 cm. in air under ordinary conditions before it is stopped, while that from radium itself is projected at a slower speed, travelling only 3.5 cm. We may regard the α particle as a projectile travelling so swiftly that it plunges through every molecule in its path, producing positively and negatively charged ions in the process. On an average, an α particle before its career of violence is stopped breaks up about 100,000 molecules. So great is the kinetic energy of the α projectile that its collisions with matter do not sensibly deflect it, and in this respect it differs markedly from the β particle, which is apparently easily deflected by its passage through matter. At the same time, there is undoubted evidence that the direction of motion of some of the α particles is slightly changed by their passage through matter.

The sudden cessation of the ionising power produced by the α particle after traversing a definite distance of air has been shown by Bragg to be a powerful method of

analysis of the number of α -ray products present in a substance. For example, suppose the amount of ionisation in the gas produced by a narrow pencil of α rays is examined at varying distances from the radium. At a distance of 7 cm. there is a sudden increase in the amount of ionisation, for at this distance the α particles from radium C enter the testing vessel. There are again sudden changes in the ionisation at distances of 4.8 cm., 4.3 cm., and 3.5 cm. These are due to the rays from the radium A, the emanation and radium itself respectively entering the testing vessel. The α -ray analysis thus discloses four types of α rays present in radium in equilibrium—a result in conformity with the more direct analysis. This method allows us to settle at once whether more than one α -ray product is present in a given radio-active material. For example, an analysis by Hahn by this method of the radiation from the active deposit of thorium has disclosed the existence of two α -ray products instead of one as previously supposed. We can consequently gain information on the complexity of radio-active material, even though no chemical methods have been found to separate the products concerned. The range of the α particle from each product is a definite constant which is characteristic of each product.

The α particle decreases in velocity as it passes through matter. This result is clearly brought out by photographs showing the deflection of a homogeneous pencil of α rays in a magnetic field before and after passing through an absorbing screen. The greater divergence of the trace of the α rays on the plate, after passing through the screen, shows that their velocity is reduced, while the sharpness of the band shows that the α particles still move at an identical speed.

In order to make an accurate determination of the constants of the α particles, it is necessary to work with homogeneous rays, and we consequently require to use a thin layer of matter of one kind. For experiments of this character, a wire coated with a thin film of radium C by exposure to the radium emanation is very suitable. The velocity of the α particle and the value e/m , the ratio of the charge carried by the α particle to its mass, can be deduced by observing the deflections of a pencil of α rays exposed in a magnetic and in an electric field of known strengths. The deflection of a pencil of α rays in an electric field is small under normal conditions, and special care is needed to determine it with accuracy.

In this way I have calculated the velocity and value of e/m for a number of α -ray products. The velocity of expulsion varies for different products, but is connected by a simple relation with the range of the α particle in air. The value of e/m has been determined for selected products of radium, thorium, and actinium, and in each case the same value has been found. This shows that the α particles expelled from radio-active substances in general are identical in constitution. They have all the same mass, but differ from one another in the initial velocity of their projection. Although we are sure that the α particles, from whatever source, are identical atoms of matter, we are still unable to settle definitely the true nature of the α particle. The value of e/m found by experiment is nearly 5×10^8 . Now the value of e/m for the hydrogen atom in the electrolysis of water is 10^8 . If the charge carried by the α particle and the hydrogen atom is the same, the mass of the α particle is twice that of the hydrogen atom, i.e. a mass equal to the hydrogen molecule. But we are not certain that they do carry the same charge. Here we are, unfortunately, confronted by a number of possibilities, for the magnitude of m for the α particle is conditioned by the value assumed for e . If the charge of the α particle is assumed to be twice the value of the hydrogen atom, the mass comes out four times the hydrogen atom—the value found for the helium atom. The weight of evidence still supports the view that the α particle is in some way connected with the helium atom. If the α particle is a helium atom with twice the ionic charge, we must regard the helium produced by radio-active bodies as actually the collected α particles the charges of which have been neutralised. This at once offers a reasonable explanation of the production of helium by actinium as well as by radium. In addition, Strutt has recently contributed strong evidence that helium is a

product of thorium. Such results are only to be expected on the above view, since the α particle is the only common product of these elements.

The determination of the true character of the α particle is one of the most pressing unsolved problems in radio-activity, for a number of important consequences follow from its solution. Unfortunately, a direct experimental proof of its true character appears to be very difficult unless a new method of attack is found. We have seen that if the charge carried by the α particle could be experimentally determined, the actual value of m could be determined in terms of the hydrogen atom, since the value of the charge carried by the latter is known. This could be done if we could devise a method of detecting the emission of a single α particle, and thus counting the number of particles expelled from a known quantity of a radio-active substance, for example, from radium. In considering a possible method of attack of this question, the remarkable property of the α particles of producing scintillations in zinc sulphide at once suggests itself. Apart from the difficulty of counting the scintillations, it is very doubtful whether more than a small fraction of the α particles which strike the screen produce the scintillations. Viewed from the electrical side, a simple calculation from the data at our disposal shows that the ionisation produced in a gas by a single α particle should be detectable. The electrometer or electroscope used for measurement would, however, require to be extremely sensitive, and under such conditions it is known that small electrical disturbances are very difficult to avoid.

In order to obtain a reasonably large effect, we require some method of magnifying the ionisation produced by the α particle. In conjunction with Dr. Hans Geiger, I have recently developed a method whereby the electrical effect produced by the α particle can be magnified several thousand times. From the work of Townsend it is known that if a strong electric field acts on gas at low pressure, any ions generated in the gas by an external agency are set in motion by the electric field, and under the proper conditions produce fresh ions by collision with the gas molecules. The negative ion is the most effective ioniser in weak fields, but when the voltage is increased near the point at which a discharge passes, the positive ion also produces fresh ions by collision. In the experimental arrangement the α particle from the active matter is fired through a small opening about 2 mm. in diameter, covered with a thin layer of mica, into a cylinder 60 cm. long and 2.5 cm. in diameter, in which the gas pressure is about 3 cm. of mercury. A thin insulated wire connected to the electrometer is fixed centrally in the cylinder. If the outside cylinder is charged negatively, for a difference of potential of about 1000 volts any ionisation produced in the cylinder is increased about 2000 times by collision. This can be simply illustrated by using the γ rays of radium as a source of ionisation. When a difference of potential is applied to the cylinder, the ionisation produced by the γ rays only causes a slight movement of the electrometer needle. By applying, however, a voltage nearly equal to that required for a discharge through the gas there is a very rapid movement of the needle. On removing the radium there is no appreciable current through the gas. On placing a source of α rays near the small opening in the cylinder so that some of the α particles can be fired along the axis of the cylinder, the electrometer needle does not move uniformly, but with a succession of rapid throws with a considerable interval in between. Each of these throws is due to the discharge produced by a single α particle entering the cylinder, increased several thousand times by the intermediary of the strong electric field. If a sheet of paper which stops the α rays is placed before the opening, the electrometer needle at once comes to rest. The interval of time between the throws is not uniform. This is exactly what we should expect if the number of α particles entering such a small opening is governed by the law of probability. On the average, a certain number of α particles are fired through the opening per minute, but in some cases the interval is less than the average, in others much greater. In fact, by observing the intervals between the entrance of a large number of α particles, we should be able to determine accurately the "probability" curve of distribu-

tion of the α particles with time. For purposes of measurements, the active material, in the form of a thin film covering a small area, is placed in an exhausted tube connected in series with the ionisation cylinder, and at a considerable distance from the hole. The number of α particles entering the opening per minute is counted, and from this the total number expelled can be calculated. Preliminary measurements show that the number of α particles expelled from a known weight of radium is of the same order as the calculated value. When the measurements are completed it should be possible to determine the charge carried by each α particle, since the total charge carried by the α particles from 1 gram of radium is known. In this way it may be possible to settle whether the α particle is a helium atom or not. In any case, it is a matter of some interest to be able to detect by its electrical effect a single atom of matter, and so to determine directly with a minimum of assumption the magnitude of some of the most important quantities in radio-active phenomena.

MEDICAL INSPECTION OF SCHOOL CHILDREN.¹

THE memorandum issued by the English Board of Education on the medical inspection of children in public elementary schools is a statesmanlike document. It propounds a policy; it indicates a method, and the method, no less than the policy, takes full account of conditions, difficulties, and obstacles. The memorandum gives body to the provisions of section 3 of the Education (Administrative Provisions) Act, 1907. This section confers three broad powers on education authorities, first, to provide special environments for special children, e.g. vacation schools, vacation classes, play centres, &c.; second, to establish a medical inspection of the individual children; thirdly, "to make such arrangements as may be sanctioned by the Board of Education for attending to the health and physical condition of the children educated in public elementary schools." These three powers may be exercised in cooperation with voluntary agencies, of which, it is needless to say, there are many. But the point of importance is that the powers may now be exercised by the education authorities, and practically, since grants may be made to depend on their exercise, the education authorities are now placed under obligation to carry them into full effect. The memorandum proceeds on this assumption; but it aims rather at sketching a process of natural administrative growth than at imposing an imperative system to be immediately realised. Accordingly, it starts from what is already being done in several localities to supervise the hygiene of schools and scholars. The sanitary authorities are in possession. This Act does not supersede, it expands and supplements, their work. Here emerges the cardinal principle of the memorandum, namely, the extension of the conception of public health to include, not merely the environmental sanitation considered apart, but the individual child's health as it is affected by his environment in the widest sense—physical, educational, &c.

The purpose of individual inspection, no less than of the general inspection of the hygienic conditions, is "to secure ultimately for every child, normal or defective, conditions of life compatible with that full and effective development of its organic functions, its special senses and its mental powers which constitute a true education." Unfortunately, owing to accidents of administrative convenience or development, there has arisen within the medical profession an acute difference of opinion as to the relative advantages of a special school medical service and an expanded public health service. Dr. Newman's appointment implied that the Board of Education favoured the idea of an expanded public health service, and this memorandum sketches in firm outline what this view implies. Incident-

¹ (1) Memorandum on Medical Inspection of Children in Public Elementary Schools, under Section 13 of the Education (Administrative Provisions) Act, 1907 (Board of Education; Circular, 276).

(2) Memorandum by British Medical Association on the Circular of the Board of Education (*British Medical Journal*, Supplement, December 21, 1907).

(3) Schedule of Medical Inspection (accompanying Circular 582).

ally, it shows that there is no opposition between the two views. On the one hand, it puts upon the medical officer of health the organising of the system of medical inspection, but on the other, it provides that "its actual execution" shall be "deputed wholly or partly to suitable colleagues or assistants (men or women)." The two factions are thus reconciled in the one administrative organisation.

The memorandum in more than one place emphasises in a way that it is impossible to controvert the primary importance of the home and its hygiene in the school-life of the child, and the absolute necessity for maintaining continuity of inspectorial interest between the home and the school. Medical inspection will thus work backwards to the home and forwards to the after-school life of the child, so covering the entire period between birth and the entry on industrial life. When this conception of continuity is fully grasped, there will be no further theoretical dispute between the medical factions concerned.

The British Medical Association has issued a memorandum dealing in a thoroughly practical spirit with the proposals and suggestions of the Board of Education. It is of immense importance that the medical profession should thus declare itself at the beginning. The differences between the association and the Board are essentially differences of detail. The association is quite frank in its acceptance of the general positions. The association's memorandum states that "these duties could not, having regard to the nature and extent of the duties already required of Medical Officers of Health, be efficiently discharged by them personally." This is not inconsistent with the Board's suggestions on the same point. The association also states that "part-time" medical officers, paid as for work done, could appropriately undertake medical inspection. This comes naturally from the profession, and there is much to say for it; but again there is nothing here inconsistent with the Board's views. But just as in the earlier, so in these later expansions of preventive medicine, the tendency will be towards "whole-time" specialists. In England many of the counties have not yet appointed whole-time or even part-time medical officers—so differing from Scotland, where every county is obliged to appoint a medical officer, and all except five have appointed whole-time men.

The association's memorandum is emphatic on another point, namely, that treatment of disease and visitation of the homes of the children shall be excluded from the scope of the medical inspector's duties. The full bearing of this suggestion will require very careful consideration. The Education Board's memorandum contains a very judicious discussion of the implications of the Act as to treatment, and it is difficult to reconcile the Act with the letter of the association's decision. The schedule proposed by the association is very well drawn, but it makes no provision for any record as to home conditions or occupation of parents, &c., which are insisted on in the Board's memorandum.

The Board of Education has followed up its memorandum by a detailed schedule, with full directions for the medical inspection. In most respects, this schedule meets all the proposals of the British Medical Association. From the tenor of the memorandum on the clear necessity for recording the home conditions and the occupational condition of the parents, we naturally expected that these points would be explicitly provided for in the schedule. In this we are somewhat disappointed; for all that we find is a heading for "Directions to Parent or Teacher." It would have been much simpler to have specified what details are wanted for every child—number of rooms in house, number of persons, occupation of father or mother, pre- and post-school labour of the child. These are all primary factors in the mental state of the child at any one time, and practically all these data are already in possession of the school authority. In other respects, the schedule is very comprehensive. Indeed, this is the one real criticism offered by medical critics. But when it is closely scrutinised, it will be found to contain only the bare essentials of a real inspection. The order of the schedule is simple, and the directive notes are models of lucidity. The anthropologist may regret that his special point of view is not as such provided for, but there is nothing

antagonistic to this either in the memorandum or in the schedule. Though not aiming directly at scientific facts, the medical inspection will certainly accumulate a vast number of facts that will form material of the first value for the anthropologist's methods.

We congratulate both the Board of Education and the British Medical Association on the practical sense displayed in these documents, and the general regard paid in each to the claims of science as well as to the claims of medicine. The great movement is now effectively inaugurated. Many points will emerge for adjustment, but these only experience can reveal. The main thing is that the work should now proceed on approximately uniform lines, and the Board of Education has given an effective lead.

FORTHCOMING BOOKS OF SCIENCE.

FOLLOWING our usual custom, we give the titles and names of authors of works relating to science which are to be found in the spring announcement lists of various publishers:—

Mr. S. Appleton:—"Minerals," by L. J. Spencer, illustrated; and "The Life and Habits of the Ants," by Dr. L. I. Dublin, illustrated.

Mr. Edward Arnold:—"Power Gas Producers, their Design and Application," by P. W. Robson.

Messrs. A. and C. Black:—"A Treatise on Zoology," edited by Sir E. Ray Lankester, K.C.B., F.R.S., part I., first fascicle, "Introduction and Protozoa," by Prof. S. J. Huxford, F.R.S., Dr. F. W. Gamble, F.R.S., J. J. Lister, F.R.S., Dr. H. M. Woodcock, and the late Prof. Weldon, F.R.S., illustrated; part vii., "Crustacea," by W. T. Calman, illustrated; part ix., "Vertebrata Craniata," by E. S. Goodrich, F.R.S., illustrated; "The Science and Philosophy of the Organism," the Gifford Lectures delivered before the University of Aberdeen in the year 1907, by Dr. H. Driesch; "Cancer: Relief of Pain and Possible Cure," by S. and G. E. Keith;

"Analytical Geometry of the Conic Sections," by the Rev. Dr. E. H. Askwith; "A Plant Book for Schools, being an Easy Introduction to the Study of Plant Life," by O. V. Darbishire, illustrated; "Descriptive Geography of the British Isles," by F. D. Herbertson, illustrated;

"Man: his Manners and Customs," by Prof. L. W. Lyde, illustrated; "School Text-book of Geography," by Prof. L. W. Lyde; and new editions of "Studies in Fossil Botany," by Dr. D. H. Scott, F.R.S., illustrated; "An Introduction to Structural Botany," by Dr. D. H. Scott, F.R.S., part ii., "Flowerless Plants," illustrated; and "Totemism," by Prof. J. G. Frazer.

Messrs. W. Blackwood and Sons:—"Stephen's Book of the Farm," by J. Macdonald; "Forest Entomology," by A. T. Gillanders; "Significant Etymology," by J. Mitchell; and "Through the Depths of Space: a Primer of Astronomy," by H. Macpherson.

Messrs. Cassell and Co., Ltd.:—"The Complete Farmer—Soils: their Nature and Management," by P. McConnell; "Cassell's ABC of Gardening: an Illustrated Encyclopædia of Practical Horticulture," by W. P. Wright, illustrated; "The Townsman's Farm," by "Home Counties"; "Familiar Swiss Flowers," by F. E. Hulme, illustrated; "Gardening for Women," by the Hon. F. Wolsey; "Structural Engineering," by Prof. A. W. Brightmore, illustrated; and "Tinplate Work," edited by P. N. Hasluck, illustrated.

Messrs. Chatto and Windus:—"A History of Babylonia and Assyria from the Earliest Times until the Persian Conquest," by L. W. King, illustrated; vol. i., "A History of Sumer and Akkad, being an Account of the Primitive Inhabitants of Babylonia from the Earliest Times to about B.C. 2000"; vol. ii., "A History of Babylonia from the Period of the First Dynasty, about B.C. 2000, until the Conquest of Babylon by Cyrus, B.C. 539"; vol. iii., "A History of Assyria from the Earliest Period until the Fall of Nineveh before the Medes, B.C. 606"; "The Open Air," by R. Jefferies, illustrated; and "Nature near London," by R. Jefferies, illustrated.

Messrs. Archibald Constable and Co., Ltd.:—"The North-West Passage: being the Record of a Voyage of Exploration of the Ship *Gjøa*, 1903-1907," by R.

Amundsen, with a supplement by First Lieut. G. Hansen, 2 vols., illustrated; "Ice-bound Heights of the Mustang: being an Account of Two Seasons of Pioneer Exploration and High Climbing in the Baltistan Himalaya," by F. B. and W. H. Workman, illustrated; "Electrical Measuring Instruments, Recorders and Meters," by K. Edgumbe; "Heavy Electrical Engineering," by H. M. Hobart, illustrated; "Steam Electric Power Plants and their Construction," by F. Korster, illustrated; "Text-book of the Steam Engine," by J. Richardson, illustrated; "Boiler Construction," by F. B. Kleinhaus, illustrated; "Hydraulics and its Application," by A. H. Gibson, illustrated; "Cranes," by A. Bötcher, translated from the German, enlarged, and edited with a complete description of English and American practice by A. Tolhausen, illustrated; "Sewage Disposal Works," by H. P. Raikes, illustrated; "Economics of American Railway Operation," by M. L. Byers, illustrated; "Railway Shop Up-to-date: a Reference Book of American Railway Shop Practice," compiled by the editorial staff of the *Railway Master Mechanic*; "Patents, Trade Marks and Designs," by K. R. Swan, illustrated; "The Manufacture of Paper," by R. W. Sindall, illustrated; "Wood Pulp and its Applications," by C. F. Cross, E. J. Bevan, and R. W. Sindall, illustrated; "Steam Engines," by J. T. Rossiter, illustrated; "Electric Lamps," by M. Solomon, illustrated; "Steam Locomotives," by V. Pendred, illustrated; "Gold and Precious Metals," by Dr. T. K. Rose; "Photography," by A. Watkins, illustrated; "Commercial Paints and Painting," by A. S. Jennings, illustrated; "Brewing and Distilling," by J. Grant, illustrated; and "Specifications and Contracts," by Dr. J. A. L. Waddell and J. C. Wait; and a new edition of "Railway Tracks and Track Work," by E. E. R. Tratman, illustrated.

Mr. H. Frowde and Messrs. Hodder and Stoughton:—"A System of Medicine," edited by Prof. W. Osler, F.R.S., and Dr. T. McCrae, 7 vols., illustrated, vols. iv. and v.; "The Collected Papers of Lord Lister," with an introduction by W. W. Cheyne, F.R.S., 2 vols.; "A System of Diet and Dietetics," under the editorship of Dr. G. A. Sutherland, introduction by Sir Lauder Brunton, F.R.S.; and "Diseases of the Eye," by S. Mayou, illustrated.

Messrs. Gauthier-Villars (Paris):—"Leçons sur les Fonctions définies par les Équations différentielles du premier Ordre," by P. Bourtroux; "Œuvres complètes," by A. Cauchy, 1ère. Série, Tome II., Mémoires extraits des Mémoires de l'Académie des Sciences; "Leçons élémentaires sur le Calcul des Probabilités," by de Montessus, illustrated; "La Terre et la Lune: Forme extérieure et Structure interne," by P. Puiseux, illustrated; "Précis d'Arithmétique des Calculs d'emprunts à Longterme et de Valeur mobilière," by H. Sarrette; and a new edition of Villard's "Rayons cathodiques," illustrated.

Messrs. Harper and Brothers:—"Hypnotic Therapeutics," by Dr. J. D. Quackenbos; "Worlds in the Making: the Evolution of the Universe," by Prof. S. Arrhenius, translated by Dr. H. Borns, illustrated; and a new edition of "The History of Science," by Dr. H. S. Williams, 5 vols., illustrated.

Messrs. G. G. Harrap and Co.:—"Manual of Clinical Chemistry," by Prof. A. E. Austin, illustrated; "A Text-book of Topographical Drawing," by F. T. Daniels, illustrated; "Feathered Game of New England," by W. H. Rich, illustrated; and "The Teaching of Practical Arithmetic to Junior Classes," by J. L. Martin, illustrated.

Mr. W. Heinemann:—"The Natural History of Cancer," by W. R. Williams.

Messrs. Hutchinson and Co.:—"The Naturalist in West Cornwall," by W. H. Hudson, illustrated; "The World's Peoples," by Dr. A. H. Keane, illustrated; and "The World's Birds, a Simple and Popular Classification of the Birds of the World," by F. Finn, illustrated.

Messrs. Longmans and Co.:—"Refrigeration: an Elementary Text-book," by J. W. Anderson, illustrated; "The Life and Work of George W. Stow, South African Geologist and Ethnologist," by Prof. R. B. Young; and "A Practical Guide to School, Cottage, and Allotment Gardening," by J. Weathers, illustrated.

Messrs. Sampson Low and Co., Ltd.:—"Mosses and Liverworts," by T. H. Russell, illustrated.

Messrs. Macmillan and Co., Ltd.:—"African Nature Notes and Reminiscences," by F. C. Selous, with a foreword by President Roosevelt, illustrated; "A Text-book of Botany," by Drs. E. Strasburger, F. Noll, H. Schenck, and A. F. W. Schimper, revised with the eighth German edition by Dr. W. H. Lang, illustrated; "Origin and Development of the Moral Ideas," by Dr. E. Westermarck, vol. ii.; "Cotton Fibre," by F. H. Bowman, illustrated; "General History of Western Nations from 5000 B.C. to 1900 A.D.," by Dr. E. Reich, vols. i. and ii.; and "Atlas Antiquus: Forty-eight Maps in Colours, on a New Graphic Plan, with Explanatory Text in English; the Names of Places, Countries, &c., on the Maps themselves being in Latin; with a full Alphabetical Index," by Dr. E. Reich.

Messrs. Methuen and Co.:—"Diseases of Occupation," by Dr. T. Oliver, illustrated; "The Causation and Prevention of Tuberculosis (Consumption)," by Dr. A. News-holme; "Folk-lore as an Historical Science," by G. L. Gomme, illustrated; "The Alps," by W. A. B. Coolidge, illustrated; "The Lore of the Honey Bee," by T. Edwardes, illustrated; "Examples in Elementary Mechanics, Practical, Graphical, and Theoretical," by W. J. Dobbs; "Outlines of Physical Chemistry," by Dr. G. Senter, illustrated; "A Health and Temperance Reader," by H. Major; "An Organic Chemistry for Schools and Technical Institutes," by A. E. Dunstan, illustrated; and "First Year Physics," by C. E. Jackson, illustrated.

Mr. Murray:—"Handbook of Commercial Products of India," by Sir G. Watt, C.I.E.; "From Peking to Mandalay: being the Account of a Journey from North China to Burma through Tibetan Szechuan and Yunnan," by R. F. Johnston, illustrated; "Pearls and Parasites: a Series of Essays on Scientific Subjects," by Dr. A. E. Shipley, F.R.S.; "The South African Natives: their Present Condition and Progress," edited by the South African Native Races Committee; "Hereditry," by Prof. J. A. Thomson, illustrated; "Therapeutics of the Circulation," by Sir T. Lauder Brunton, F.R.S.; and "Educational Woodwork on Scientific Lines," by J. T. Baily and S. Pollitt, illustrated.

Messrs. Kegan Paul and Co., Ltd.:—"Introduction to the Science of Electricity," lectures by B. Kolbe, authorised translation by J. Skellon, illustrated; "The Steam Engine and other Steam Motors," by R. C. H. Heek, illustrated; "The Evolution of Modern Physics," by Prof. L. Poincaré; "The Evolution of Forces," by Dr. G. Le Bon; "The Radio-active Substances, their Properties and Behaviour," by W. Makower; "Music: its Laws and Evolution," by J. Combarieu; "The Transformations of the Animal World," by M. C. Depéret; "Practical Dairy Bacteriology: for Students, Dairymen, and all interested in the Problems of the Relation of Milk to Public Health," by H. W. Conn; "Insects Injurious to Vegetables," by F. H. Chittenden, illustrated; "First Principles of Soil Fertility," by A. Vivian, illustrated; "Farm Machinery and Motors," by B. Davidson and L. W. Chase, illustrated; and a new edition of "Alternating Current Engineering, Practically Treated," by C. B. Raymond, illustrated.

Messrs. George Philip and Son, Ltd.:—"A Rational Geography," by E. Young; part ii., "Tides, Winds, Currents, Latitude and Longitude, and Geography of America and Africa," part iii., "Map Drawing, Map Projection, Surveying, and Geography of Asia and Australasia"; and "A Guide to the Choice of Geographical Text-books."

Sir Isaac Pitman and Sons, Ltd.:—"Notes of Lessons on Science"; "The Teacher's Certificate Science"; "Notes of Lessons on Hygiene and Temperance," 2 vols.; "Notes of Lessons on Arithmetic," 2 vols.; and "Notes of Lessons on Geography," 2 vols.

Messrs. G. P. Putnam's Sons:—"Elements of Plane and Spherical Trigonometry," by Prof. J. H. Gore; "Alpine Flora of the Canadian Rocky Mountains," by S. Brown, illustrated; "Mosquitoes: the Habits and Life Cycles of the known Mosquitoes of the United States; Methods for their Control; and Keys for easy Identifica-

tion of the Species in their Various Stages," an account based on the investigations of the late James William Dupree, Surgeon-General of Louisiana, and upon original observations by the writer, by E. G. Mitchell, illustrated; "The Muscles of the Eye," by Dr. L. Howe, 2 vols., illustrated; and a new edition of "Thinking, Feeling, Doing: an Introduction to Mental Science," by Dr. E. W. Scripture, illustrated.

Messrs. Alston Rivers, Ltd.:—"Water: its Origin and Use," by C. C. Finch.

Messrs. Smith, Elder and Co.:—"Animal Life," by Dr. F. W. Gamble, F.R.S., illustrated; and a new edition of "Hardy Ornamental Flowering Trees and Shrubs," by A. D. Webster.

Messrs. Swan Sonnenschein and Co., Ltd.:—"The History and Ethnography of Africa South of the Zambezi from the Settlement of the Portuguese at Sofala in September, 1505, to the Conquest of the Cape Colony by Great Britain in September, 1795," by Dr. G. M. Theal, vols. ii. and iii.; "The History of Philosophy, based on the Work of Dr. J. E. Erdmann," by W. S. Hough; "Introduction to the Study of Philosophy," by Prof. O. Kulp, translated by Prof. E. B. Titchener; "Outlines of Psychology," by Prof. O. Kulp, translated under the supervision of Prof. E. B. Titchener; "Physiological Psychology," by Prof. W. Wundt, a translation of the fifth and wholly re-written German edition by Prof. E. B. Titchener, vol. ii., illustrated; "The Student's Text-book of Zoology," by Prof. A. Sedgwick, F.R.S., vol. iii., completing the work, illustrated; "Electricity: What is It?" by W. D. Verschoyle, illustrated; "Plant Life: a Manual of Botany for Schools," by Prof. E. Warming, translated by M. Rehling and E. M. Thomas, illustrated; and new editions of "A Text-book of Petrology," by Dr. F. H. Hatch, illustrated; "Elementary Text-book of Practical Botany for the Botanical Laboratory and Private Student," by Prof. E. Strasburger, translated by Prof. W. Hillhouse; and "An Elementary Text-book of Botany," by Prof. S. H. Vines, F.R.S., illustrated.

Messrs. E. and F. N. Spon, Ltd.:—"Facts, Figures, and Formulae for Irrigation Engineers: being a Series of Notes on Miscellaneous Subjects connected with Irrigation," compiled by R. B. Buckley; and a new edition of "Leather Industries Laboratory Book of Analytical and Experimental Methods," by Prof. H. R. Procter.

The University Tutorial Press, Ltd.:—"Geometry, Theoretical and Practical," part ii., by W. P. Workman and A. G. Cracknell; Elementary Science for the Certificate Examinations (Certificate and Preliminary Certificate):—"Section A: Chemistry," by H. W. Bausor; "Section B: Physics," by J. Satterley; "Section C: Botany," by Prof. F. Cavers; and "Junior Chemistry," by R. H. Adie.

Mr. T. Fisher Unwin:—"Nature Studies by Night and Day," by F. C. Snell; and "Health at its Best v. Cancer and other Diseases," by R. Bell.

Messrs. Watts and Co.:—"A sixpenny edition of Prof. Huxley's 'Man's Place in Nature.'"

Messrs. Williams and Norgate:—"The Surgical Anatomy of the Horse," by J. T. S. Jones, part iii., illustrated; and a new edition of "Principles and Practice of Agricultural Analysis: a Manual for the Study of Soils, Fertilisers, and Agricultural Products," by H. W. Wiley, vol. ii.

Messrs. Witherby and Co.:—"Three Voyages of a Naturalist: being an Account of many Little-known Islands in Three Oceans visited by the *Valhalla*, R.Y.S.," by M. J. Nicoll, with an introduction by the Right Hon. the Earl of Crawford, K.T., F.R.S., illustrated.

UNIVERSITY AND EDUCATIONAL INTELLIGENCE.

CAMBRIDGE.—There is a desire on the part of the biologists of Cambridge to celebrate in 1909 the centenary of Darwin's birth and the jubilee of the publication of the "Origin of Species" by endeavouring to found a chair of biology, the occupant of which shall devote himself to those subjects which were the chief concern of Darwin's life-work. It is probable that this will be accomplished; for the council of the Senate has had under consideration

a generous offer of support made by a member of the University who wishes to remain anonymous.

Convinced of the great importance of the subjects with which such a professorship would be concerned, the benefactor offers to pay to the University 300*l.* a year for five years, provided that the University establishes for that period, and before June 30, 1908, a professorship of biology of the minimum annual value of 500*l.*

The donor also offers to increase the 300*l.* to 400*l.* for any portion of the five years during which the professor may be holding a professorial fellowship. The further condition is made that it shall be the duty of the professor or professors elected during the period of five years above mentioned to teach and make researches in that branch of biology now entitled genetics (heredity and variation).

The author of this offer further suggests, though he does not make it a condition, that the proposed temporary professorship, if established, should be entitled the "Darwin Professorship of Biology." The council of the Senate, while giving full weight to this suggestion, inclines to the view that it would be more expedient to reserve such a title until it shall have become clear that the professorship can, from whatever source, be placed on a permanent footing.

The council is of opinion that the generous offer anonymously made should be accepted, and that a professorship of biology of the value of 700*l.* per annum should be established, which will terminate at the end of the Easter term, 1913, unless the University shall previously have otherwise determined. The electors to the professorship shall, so long as the professorship is only temporary, be the council of the Senate, but if the professorship shall be made permanent a board of electors shall be constituted.

It is proposed to make a grant of 30*l.* from the Worts fund to Mr. A. R. Hinks, of Trinity College, towards defraying his expenses in travelling on the continent of Europe with the view of investigating the methods used in the study of astronomy and geodesy in certain observatories and institutions.

It is proposed to continue for a further period of five years, from Michaelmas, 1908, the Caley and Stokes lectureships in mathematics, the annual stipend of 200*l.* being attached to each lectureship. The general board is of opinion that, should the endowments for these two lectureships prove to be insufficient to provide these stipends, the University should undertake to make up for the five years any deficiency which may result from this insufficiency. This may involve a contribution from the University of 80*l.* a year.

Mr. C. A. Barber and Mr. A. W. Rogers have been approved by the general board of studies for the degree of Doctor in Science.

The syndicate appointed to obtain plans and estimates for the extension of the chemical laboratory has issued a second report, in which it is stated that last August a contract was signed by the builder for erecting the building, which is now rising in Pembroke Street, at a cost of 13,750*l.* The syndicate now asks leave of the Senate to expend a sum of 485*l.* for extras in the building, 2455*l.* for benches, lecture tables, and other fittings, and 700*l.* for instruments and apparatus.

LONDON.—The degree of D.Sc. in chemistry has been granted to Mr. R. J. Caldwell, an internal student of the Central Technical College. Mr. Caldwell presented a thesis entitled "A.—Studies of the Processes Operative in Solutions, part i., the Sacroclastic Action of Acids as influenced by Salts and Non-electrolytes; B.—The Hydrolysis of Sugars," and other papers.

The degree of D.Sc. in zoology has been granted to Mr. D. H. de Souza, an internal student of University College. Mr. de Souza presented a thesis entitled "The Activation of Pancreatic Juice."

THE death is announced of Prof. Laurent, professor of mathematical analysis in the Paris École polytechnique and Institut national agronomique.

MISS E. N. THOMAS, assistant in the department of botany, University College, has been appointed lecturer

and head of the department of botany, Bedford College for Women.

M. CAMILLE MATIGNON has been appointed professor of mineral chemistry at the Collège de France in succession to M. H. Le Châtelier, who recently accepted the chair of general chemistry at the Sorbonne.

THE governing body of the Imperial College of Science and Technology has appointed as secretary Mr. Alexander Gow, formerly scholar of Gonville and Caius College, Cambridge, who for the last four years has occupied the position of director of education and principal of the Technical School, Blackburn.

IN THE House of Commons on Monday Mr. Ramsay MacDonald asked the President of the Board of Education whether he proposed to appoint a Royal Commission to inquire into the constitution of the University of London, with a view to the University taking over the Imperial School of Science and Technology, or whether, in the event of no such commission being appointed and the school being in consequence maintained as a separate foundation, he would reconsider the constitution of the governing body of the school so as to strengthen it on its industrial side with the view of establishing a connection between it and technological institutions of lower grades. In reply, Mr. McKenna said that no representations had reached him from the bodies principally concerned leading him to suppose that the consideration of this question is urgently desired, and that no commission would be appointed unless these representations were made.

THE thirtieth annual meeting of the Institute of Chemistry was held on Monday, March 2, Prof. P. F. Frankland, F.R.S., president of the institute, being in the chair. In the course of his address the president dealt with the difficulties of students in deciding the most advisable method of preparing for admission to the profession of chemistry. He is convinced that the usual three years' curriculum is wholly inadequate, for whilst the ground to be covered in the study of chemistry has attained colossal dimensions compared with what it was twenty-five years ago, and is continually being extended, the student's time is no more protracted than before. The limited time at the disposal of the student gives him little opportunity to take proper advantage of the excellent equipment now to be found in the universities and colleges, and teachers are aware of the urgent necessity of increasing the minimum length of the curriculum prior to graduation, but so university appears to have the courage to initiate this reform. In the matter of students, it is quality, not quantity, that universities require, for every science student is a net loss financially, and the work of the classes is too often hampered by a large proportion of undesirables.

THE Board of Education has published (Cd. 3885) the reports from those universities and university colleges in Great Britain which participated during the year ended March 31, 1907, in the annual Parliamentary grant, now amounting to 100,000*l.* The reports deal with the work of the colleges during the year 1905-6, and appear to be reprinted just as they were received by the Board of Education. The information is arranged, it is true, under headings prescribed by the Board, such as land and buildings, staff and educational work, students, fees, finance, and so on, and it is possible with much labour to institute comparisons between the various institutions. The usefulness of the Blue-book would be increased greatly if, following the practice adopted in many other of the Board's publications and the custom which is fairly general in American volumes of a similar kind, the statistics relating to the various colleges were summarised and the totals obtained for the different institutions classified and compared. It would then be possible to coordinate the facts, and to say, for instance, how the interest in higher education in the north of England compares with that in the Midlands or in Wales. If some such plan were adopted much greater use would be made of what would then be an interesting and serviceable volume.

THE interim report for the period January 1 to September 30, 1907, submitted on February 25 last to the trustees by the executive committee of the Carnegie trust for the

universities of Scotland, gives information concerning the allocation of grants during that period. The publication of this interim report, dealing only with nine months, was necessitated by an alteration of the financial year of the trust to bring it into line with the academic year of the universities. Sums amounting to 22,000*l.* have been handed over to the four Scottish universities during the nine months, bringing the total expenditure in this direction, since the inauguration of the first quinquennial scheme of grants in January, 1903, to 156,489*l.* The conditions which will regulate the second quinquennial distribution are under the consideration of a special sub-committee, and will, it is hoped, be published shortly. The total expenditure for 1906-7 under the scheme of endowment of post-graduate study and research was 700*l.*, and the estimated expenditure for the current academic year is 761*l.* The expenditure upon fees for the summer session, 1907, amounted to 11,685*l.* The proposed scheme of inclusive fees, that is, that in each faculty a beneficiary of the trust should be granted all such instruction as it is desirable for him to receive in his course for a degree on the payment of one fee for each academic year, is still under discussion. Numerous appendices to the report provide detailed information as to the different items of expenditure.

SOCIETIES AND ACADEMIES.

LONDON.

Royal Society, December 12, 1907.—"Further Consideration of the Stability of the Pear-shaped Figure of a Rotating Mass of Liquid." By Sir G. H. Darwin, K.C.B., F.R.S.

In vol. xvii., No. 3 (1905), of the Memoirs of the Imperial Academy of St. Petersburg, M. Liapounoff has published an abstract of his work on figures of equilibrium of rotating liquid. In this paper he explains how he has obtained a rigorous solution for the figure and stability of the pear-shaped figure, and he pronounces it to be unstable. In a paper in the Philosophical Transactions (vol. cc., A, pp. 251-314) the present author arrived at an opposite conclusion.

The stability or instability depends on whether the sign of a certain function is negative or positive.

M. Liapounoff attributes the disagreement to the fact that the author only computed a portion of an infinite series, and only used approximate forms for the elliptic integrals involved in the several terms. He believes that the inclusion of the neglected residue of the infinite series would lead to an opposite conclusion.

In the author's computation the critical function is decisively negative, whilst M. Liapounoff is equally clear that it is positive. The inclusion of the neglected residue of the series, which forms part of the function, undoubtedly tends to make the whole function positive, but after making the revision it remained incredible, at least to the author, that the neglected residue should amount to the total needed to invert the sign.

The analysis of his former investigation was re-examined throughout, and the computations were repeated by improved methods. The same method was also applied to the investigation of Maclaurin's spheroid, where the solution could be verified by the known exact result.¹

Dissent from so distinguished a mathematician as M. Liapounoff is not to be undertaken lightly, and therefore special pains were taken to ensure correctness. The author states his conviction that the source of the disagreement is to be found in some matter of principle, and not in the neglected residue of this series.

Entomological Society, February 5—Mr. C. O. Waterhouse, president, in the chair.—*Exhibits*.—Dr. T. A. Chapman: A collection of butterflies made last summer at Gavarnic, in the Pyrenees, including a number of specimens of *Erebia lefebvrei*, with *E. melas* from south-east Hungary, for comparison.—H. St. John Donisthorpe: Eleven species of ants taken in the hot-houses in Kew Gardens in December, 1907, and January, 1908, eight

¹ Amer. Math. Soc. Trans., 1903, vol. iv., p. 112, on "The Approximate Determination of the Form of Maclaurin's Spheroid," and a further note on the same subject recently sent to the same society.

being new to the published Kew list, and six species not before recorded as introduced in Britain.—J. E. Collin: Microscopically mounted specimens of the gnat *Epidapus scabiei*, Hopk., a potato pest in the United States recently discovered in England attacking narcissus bulbs.—A. H. Hamm: Very young larvæ of *Bitaris muralis*, hatched in captivity, the natural place of deposit of these eggs being at the entrance to the burrow of the bee, *Anthophora philipes*, in stone walls near Oxford.—Commander Walker: Two specimens of the rare *Pyralis tienigialis*, Zell, ♀, taken at light in his house at Summertown, August, 1906, and 1907.—R. E. Turner: A box of Thynnidae from South America, mostly from Chile, with several new species from Mendoza and the Peruvian Andes.—Prof. T. Hudson Beare: A specimen of *Trachyphlaeus scabriculum* taken at St. Margaret's Bay in August, 1907, with the two deciduous mandibles still in place.—Lieut.-Colonel Manders: The ♀ of *Papilio phorbanta* from Bourbon, an aberrant member of the Nireus group of Papilios, compared with the other members of the same group from the African mainland, Madagascar, and Mauritius. It was pointed out that whereas in all the other species the ♀♀ were some shade of green similar to the ♂♂, the Bourbon insect was more or less uniformly brown. It was suggested that this was due to mimicry, *Euplaea goudoti*, a species strictly confined to Bourbon, being the model.—Hon. Walter Rothschild: Interesting papilionids; (1) *Troides alexandrae*, Rothschild, remarkable for the beauty of the ♂ and the gigantic size of the ♀, a new discovery by A. S. Meek, who found this fine insect in the north-eastern portion of British New Guinea at some distance inland from the coast; (2) a gynandromorphic specimen of *Troides*, the only one known of this genus, obtained by Dr. L. Martin in South Celebes. It belongs to *T. haliphron*, the left side being ♀ and the right side ♂.—R. Adkin: Bred specimens of *Tortrix prunabana*, Hb., to demonstrate that the species is continuously brooded.—L. W. Newman: Long series of *Melittaea aurinia* and *Notodontia chaonia* from various localities in the United Kingdom to illustrate the wide superficial variation of the respective species.—Dr. F. A. Dixey: Specimens of *Nychitona medusa*, Cram., and *Pseudopontonia paradoxa*, Feld.—*Papers*.—(1) Two dipterous Hymenoptera from Queensland; (2) notes on Thynnidae, with remarks on some aberrant genera of the Scotiidae.—R. E. Turner.—Diapausematism, with reference to some limitations of the Mullerian hypothesis of mimicry: G. A. K. Marshall.

Zoological Society, February 18.—Dr. Henry Woodward, F.R.S., vice-president, in the chair.—A series of specimens of internal parasites obtained from animals recently living in the society's gardens: Dr. L. W. Sambon. Stress was laid on the important additions to knowledge to be derived from an adequate investigation of such material, and on the practical results to the health of the animals in the gardens that might be expected.—The inheritance of colour in domestic pigeons, with special reference to reversion: R. Staples-Browne. A series of skins was exhibited illustrating some experiments upon which the communication was based. Crosses had been made between black barbs and white fantails. The F₁ generation was black with some white feathers. In the F₂ generation, among other forms, blacks and whites were obtained, and also some blues. Blues were found to be dominant to whites, but blacks were dominant, or rather "epistatic," to the blues, which accounts for the fact that the reversionary form does not appear until the F₂ generation. When two blues of the F₂ or later generations were mated together blacks were never obtained again. A white in F₂ mated to a fantail gave whites only. A second series of skins illustrated a cross between a white tumbler and a white fantail. Some white birds splashed with red had figured in the ancestry of the tumbler, although the bird itself showed no trace of colour. In the F₁ generation such splashed kinds occurred, which, when mated together, gave in F₂ birds which were red and white with some distinct blue feathers. Possibly the white tumbler was a dominant white.—Mammals collected by Mr. M. P. Anderson during a trip to the Mongolian Plateau, N.W. of Kalgan: O. Thomas. Nine species were mentioned, of which two were described as new. The paper formed the

eighth of the series on the results obtained by the Duke of Bedford's zoological exploration in eastern Asia. No properly collected material from the Mongolian plateau had been previously available to students, and these specimens, representatives of its comparatively poor fauna, were therefore of much interest.—Butterflies of the division Rhopalocera from Africa and from New Guinea: G. T. **Bethune-Baker**.

Chemical Society, February 20.—Sir William Ramsay, K.C.B., F.R.S., president, in the chair.—Organic derivatives of silicon, part vi., the optically active sulphobenzylethylpropylsilyl oxide: F. S. **Kipping**. The sulphonic acids obtained by resolving *dl*-sulphobenzylethylpropylsilyl oxide have been further studied, and the two acids are shown to be optically active, enantiomorphously related compounds having the constitution



—The preparation of conductivity water: H. **Hartley**, N. P. **Campbell**, and R. H. **Poole**. A still has been constructed which in one operation gives a fair yield of water with a conductivity 0.75 gemmho at 18°, starting from ordinary distilled water with a conductivity of 5 gemmhos.—Derivatives of *para*-diazoinobenzene: G. T. **Morgan** and Miss F. M. G. **Micklethwait**.—The affinity constants of bases as determined by the aid of methyl-orange: V. H. **Veley**. Results were given for the hydrochlorides of (1) bases not containing an alkyl group; (2) aliphatic amines; (3) amino-acetic acids; and (4) uric acid derivatives.—The action of thionyl chloride and of phosphorus pentachloride on the methylene ethers of catechol derivatives: G. **Barger**.—A study of the diazo-reaction in the diphenyl series: G. T. **Morgan** and Miss F. M. G. **Micklethwait**. The arylsulphonylbenzidines, $RSO_2.NH.C_6H_4.C_6H_4.NH_2$, furnish yellow crystalline diazonium salts giving rise on treatment with aqueous sodium acetate to dark brown crystalline compounds, which are either monohydrated nitrosoamines,



or dihydrated diazoimides, $\begin{matrix} C_6H_4.N_2 \\ | \\ C_6H_4.N.SO_2R_2.H_2O \end{matrix}$. The diazonium salts of the arylsulphonylalkylbenzidines,



although distinctly less coloured than those of the unalkylated bases, have nevertheless not been obtained in a colourless condition. There is accordingly no reason for supposing that the diazonium salts of the alkylated bases are differently constituted from those which still contain the labile acidic hydrogen atom (*).—A simple manometer for vacuum distillation: N. L. **Gebhard**.—Researches on the anthraquinones: W. H. **Bentley** and C. **Weizmann**. The condensation products of phthalic and hemipinic anhydrides with veratrole and pyrogallol trimethyl ether are described.—The formation of 4-pyrone compounds from acetylenic acids, part i.: S. **Ruhemann**.—The action of mustard oils on the ethyl esters of malonic and cyanoacetic acids: S. **Ruhemann**.—The triazo-group, part ii., azoimides of propionic ester and of methyl ethyl ketone: M. O. **Forster** and H. E. **Fierz**. On comparing the behaviour of the α - and β -triazio-derivatives of ethyl propionate towards alkali, it was found that, whilst the first-named resembles triazoacetic ester, ethyl β -triazio-propionate rapidly parts with hydrozoic acid.—Brazilin and haematoxilin, part viii., synthesis of brazilinic acid, the lactones of dihydro-brazilinic and dihydrohaematoxilic acids, anhydrobrazilic acid, &c. The constitution of brazilin, haematoxilin, and their derivatives: W. H. **Perkin**, jun., and R. **Robinson**. Further confirmation of the constitution (Proc., 1907, xxiii., 291) of the members of this group is afforded by the synthesis of anhydrobrazilic acid, which has been proved to possess the formula

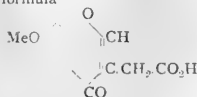

EDINBURGH.

Royal Society, February 17.—Dr. John Horne, F.R.S., vice-president, in the chair.—The systematic motion of the stars: Prof. **Dyson**. A careful study of 1500 stars having large proper motions corroborated Kapteyn's hypothesis that the stars moved in two well-defined streams crossing each other in space.—Preliminary note on *Lepidophloios Scotti*, a new species from the Calceiferous Sandstone series at Petycur, Burntisland: W. T. **Gordon**. Some of the diagnostic features of this new species named after Dr. D. H. Scott are:—(1) the short straight ligular canal the opening of which is protected by the overlying leaf base, and which opens far back from the leaf scar; (2) a marked concavity of the leaf base from half-way between the opening of the ligular canal and the leaf scar to the leaf scar itself; (3) the comparatively long course of the parichnos before it forks.—The middle cells of the grey matter of the spinal cord: Dr. J. H. **Harvey Pirie**. The description of the anatomical arrangement of these small cells showed that Argutinski was wrong in ascribing a segmented character to the group, and that the cells extended throughout the whole length of the cord, being specially numerous in the two enlargements.—*g*-Functions and a certain difference operator: Rev. F. H. **Jackson**.

PARIS.

Academy of Sciences, February 24.—M. H. Becquerel in the chair.—M. B. Baillaud was elected a member of the section of astronomy in the place of the late M. Lœwy.—Results of the measurements of the diameters of Mercury during its transit of November 14, 1907: Robert **Jonckheere**. The mean diameter is 9'10, higher than the figure usually accepted, 8'68. A table of results is given.—Observations of the sun made at the Observatory of Lyons during the fourth quarter of 1907: J. **Guillaume**. The results are summarised in three tables showing the number of spots, the distribution of the spots in latitude, and the distribution of the faculae in latitude.—Researches on the dispersion of light in celestial space: Charles **Nordmann**. From measurements on two fixed stars by the photometric method previously described by the author, the conclusion is drawn that light undergoes a dispersion in space. These results can be applied to give new indications of the parallax of variable stars.—The congruences of plane curves: C. **Popovici**.—Remarks on a communication of M. E. E. Levi: E. **Holmgren**. A question of priority.—The singularities of differential equations of the first order: Georges **Rémoundos**.—Images the appearance of which changes with a projection screen ruled as a grating: E. **Estanave**.—The influence of sunlight on the disengagement and on the orientation of the gaseous molecules in solution in sea-water: Raphael **Dubois**. If test-tubes containing various coloured solutions are plunged into sea-water and the whole exposed to the sun, it is noticed that bubbles of gas are deposited on the outside wall of the tube. If the solution in the tube is green, the evolution of gas, which is rich in oxygen, is much greater than with the other colours. That this is not due to the selective absorption of calorific radiations was shown by substituting water charged with carbon dioxide for the aerated sea-water; the increased effect with the green tube was not observed.—The curves of induced radio-activity obtained by MM. Sarasin and Tommasina: J. **Danne**. An explanation of the results of these authors, by considering the distribution of the field in the different parts of the measuring apparatus.—The method of working of the electrolytic detector: the influence of temperature: Henri **Abraham**. The change in capacity and resistance of the electrolytic detector caused by raising the temperature to 120° C. gives several advantages in practical working.—The atomic weights of nitrogen, oxygen, and carbon: A. **Leduc**. The International Committee on Atomic Weights has now lowered the atomic weight of nitrogen from 14.044 to 14.01. Using this figure and the ratio of the densities of carbon monoxide and nitrogen, as determined experimentally by Lord Rayleigh and by the author, it is shown that the atomic weight of carbon must lie between 12.011 and 12.016.—Phosphorus oxybromide: E. **Berger**. Phosphorus pentabromide heated with phosphorus pentoxide gives a good yield (85 per cent.) of phosphoryl bromide.—This forms

crystals, melting at 56° C. and boiling at 186.5 C. under 774 mm. Its vapour density is normal. The heat of formation has also been determined.—The essentially chemical causes of the allotropic transformation of white phosphorus dissolved in essence of turpentine: **Albert Coison**.—An isomeric modification of hydrated hypovanadic acid: **Gustave Gain**. The other $V_2O_5 \cdot 2H_2O$ exists in two forms, one green and the other rose colour. The change from one of these isomers to the other is accompanied by a thermal change, and this has been measured in the calorimeter.—**Lutecium** and **neoytterbium**: **G. Urbain**. The fact that **Marignac's** ytterbium can be separated into two elements differing in atomic weight by more than three units was briefly described by the author three months ago. The present communication contains fuller details of the methods and results. These results have been confirmed by **Auer von Welsbach**, who has described the two elements thus separated under the names of **aldealbarium** and **cassiopeium**. The former of these is identical with **lutecium**, and the latter with **neoytterbium**.—The action of **sulphosalicylic acid** upon **borax**: **L. Barthe**.—The action of nascent hypiodous acid (iodine and sodium carbonate) upon some acids of the general formula

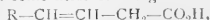

R being the phenyl group more or less substituted: **J. Bougault**. The product of this action is an acid of the general formula $R-CO-CH=CH-CO_2H$.—**Antiamylase** serum: **C. Gossard** and **J. Wolff**. Quantitative studies on an enzyme preventing the action of malt extract upon starch.—The action of amylase of the pancreatic juice and its stimulation by the gastric juice: **H. Bierry**.—Note on the existence of products of cellular degeneration recalling **Negri's** bodies: **Y. Manouélian**.—The measurement of the ventricular wave in man: **Gabriel Arthaud**.—The fixation, multiplication, and mode of attack of pathogenic trypanosomes in the proboscis of the tsetse-fly: **E. Roubaud**.—The genus **Dolicoecystis**: **L. Brasil**.—Stratigraphical researches in eastern Morocco: **Louis Gentil**.—Primary strata of Morvan and the Loire: **Albert Michel-Lévy**.—The extension of the Oligocene depressions in a part of the central **massif**, and their rôle in the hydrological point of view: **Ph. Glangeaud**.—New researches on the rare gases of thermal springs. Yields of gas in certain cases: **Charles Moureu** and **Robert Biquard**. The gases from nine springs have been examined. The proportions of the rare gases, taken together, vary from 1.24 per cent. to 6.39 per cent., the helium from 0.097 per cent. to 5.34 per cent. The total quantity of helium thus obtainable is very large, a spring at Bourbon-Nancy giving 10,000 litres per annum. The helium was separated by means of charcoal at the temperature of liquid air boiling under reduced pressure, and contained only a trace of neon as impurity.

DIARY OF SOCIETIES.

THURSDAY, MARCH 5.

ROYAL SOCIETY, at 4.30.—On the Atomic Weight of Radium: **Dr. T. E. Thorpe**, C.B., F.R.S.—On the Electrical Resistance of Moving Matter: **Prof. P. T. Trouton**, F.R.S., and **A. O. Rankine**.—On the Nature of the Streamers in the Electric Spark: **Dr. S. K. Milner**.—The Relation between Wind Velocity at 1000 Metres, Altitude and the Surface Pressure Distribution: **E. Gold**.
ROYAL INSTITUTION, at 3.—Early British History and Epigraphy: **Sir John Rhys**.
CHEMICAL SOCIETY, at 8.30.—The Solubility of Iodine in Water: **H. Hartley** and **N. P. Campbell**.—Traces of a New Tin-group Element in Thorianite: **Miss C. de B. Evans**.
INSTITUTION OF ELECTRICAL ENGINEERS, at 8.—Fuse Phenomena: **Prof. A. Schwartz** and **W. H. N. James**.
LANSLET SOCIETY, at 8.—On the Morphology of Stigmara in Comparison with Recent Lycopodiaceae: **Prof. F. E. Weiss**.—On *Trichionoides albidus* and *T. savasi*: **Alexander Patience**.—*Eshbitis*: Fruit Destroying Flies: **W. W. Griggall**.—Mimicry in the Common Sole: **Dr. A. T. Masternan**.

FRIDAY, MARCH 6.

ROYAL SOCIETY, at 9.—The Figure and Constitution of the Earth: **Dr. L. A. B. Selwyn**.
INSTITUTION OF CIVIL ENGINEERS, at 8.—Surveying on Thunder Bay and the Grand Trunk Pacific Railway, Canada: **R. V. Morris**.—Practice in Railway Surveying: **W. Graham**.—Railway Surveying in the Straits: **W. C. Crawford**.
GEOLOGICAL ASSOCIATION, at 8.—The After-history of the West Indian Eruption of 1802: **Dr. Tempest Anderson**.

THURSDAY, MARCH 7.

ROYAL SOCIETY, at 8.30.—Electric Discharges through Gases: **Prof. J. J. Thomson**.

MONDAY, MARCH 9.

ROYAL SOCIETY OF ARTS, at 8.—Fuel and its Future: **Prof. Vivian B. Lewes**.
ROYAL GEOGRAPHICAL SOCIETY, at 8.30.—Exploration in Southern Nigeria: **Lieut. E. A. Steel**.
THURSDAY, MARCH 10.
ROYAL INSTITUTION, at 3.—Membranes: Their Structure, Uses and Products: **Prof. W. Stirling**.
ROYAL ANTHROPOLOGICAL INSTITUTE, at 8.15.—The Origin of the Crescent as a Monumental Badge: **Prof. W. Ridgeway**.—Some Prehistoric Antiquities in Central France: **A. L. Lewis**.
INSTITUTION OF CIVIL ENGINEERS, at 8.—Further discussion: The New York Rapid-transit Subway: **W. B. Parsons**.
WEDNESDAY, MARCH 11.
ROYAL SOCIETY OF ARTS, at 8.—The Use of Reinforced Concrete in Engineering and Architectural Construction in America: **Ernest R. Matthews**.
ROYAL METEOROLOGICAL SOCIETY, at 7.30.—Lecture on the Dawn of Meteorology: **Dr. G. Hellmann**.
THURSDAY, MARCH 12.
ROYAL SOCIETY, at 4.30.—Probable Papers.—Description of the Brain of **Mr. Charles Babbage**, F.R.S.: **Sir Victor Horsley**, F.R.S.—The Origin and Destiny of Cholesterol in the Animal Organism. Part II. The Excretion of Cholesterol by the Dog: **C. Doree** and **J. A. Gardner**.—On Reciprocal Innervation in Vasomotor Reflexes and the Action of Strychnine and of Chloroform thereon: **Dr. W. M. Bayliss**, F.R.S.—Bacteria as Agents in the Oxidation of Amorphous Carbon: **Prof. M. C. Potter**.
ROYAL INSTITUTION, at 3.—Early British History and Epigraphy: **Sir John Rhys**.
ROYAL SOCIETY OF ARTS, at 4.30.—Progress in the Native States of India during the past Forty Years: **Sir David W. K. Barr**, K.C.S.I.
MATHEMATICAL SOCIETY, at 5.30.—On the Projective Geometry of some Covariants of a Binary Quintic: **Prof. E. B. Elliott**.—On the Inequalities connecting the Double and Repeated Upper and Lower Integrals of a Function of Two Variables: **Dr. W. H. Young**.—On the Operational Expression of Taylor's Theorem: **W. F. Sheppard**.—A Proof of a Theorem of **Fermat's**: **Dr. H. A. P. de S. Pittard**.
INSTITUTION OF ELECTRICAL ENGINEERS, at 8.—America Re-visited, 1907: **Sir W. H. Preece**, K.C.B., F.R.S.

CONTENTS.

	PAGE
The Evolution of Astronomical Instruments	409
Nature and Nurture of the Child. By T. P. N.	410
Our Book Shelf:—	
Walker: "The Essentials of Cytology."— J. B. F.	410
Bolduan: "Immune Sera"	411
Rainbow: "A Guide to the Study of Australian Butterflies."— W. F. K.	411
Polak: "The Theory and Practice of Perspective Drawing"	411
Popplewell: "Strength of Materials"	412
Letters to the Editor:—	
Lithium in Radio-active Minerals.— Sir W. Ramsay , K.C.B., F.R.S.	412
Formation of Ground-ice.— Prof. H. T. Barnes	412
The Possibility of Life on Mars.— Dr. J. W. Evans	413
A Fundamental Contradiction between the Electrical Theory of Dispersion and the Phenomena of Spectrum-series.— Dr. G. A. Schott	413
Notes on Ancient British Monuments. VI.— Dolmens . (<i>Illustrated</i> .) By Sir Norman Lockyer , K.C.B., F.R.S.	414
Experiments on Screw Propellers	416
Notes	417
Our Astronomical Column:—	
Astronomical Occurrences in March	421
Micrometer Observations of Phebe	421
Ephemeris for Daniel's Comet, 1907d	421
The Spectrum of the Aurora Borealis	421
Sun-spot Spectra	421
Astronomy in Wales	421
Recent Advances in Radio-Activity. (<i>With Diagram</i> .) By Prof. E. Rutherford , F.R.S.	422
Medical Inspection of School Children	426
Forthcoming Books of Science	427
University and Educational Intelligence	428
Societies and Academies	430
Diary of Societies	432

SUPPLEMENT.

Physiological Stimulus and Response. By L. H.	iii
The Stereoscope and Stereoscopic Instruments	iv
American Physical Geography. By J. W. G.	v
Polyperiodic Functions. By G. B. M.	v
Reinforced Concrete. By T. H. B.	vi
The Evolution of Dress	vii
Modern Views of Electricity. By N. R. C.	viii
England an Example for Germany	viii
Wireless Telegraphy and Telephony. By M. S.	ix
The Tabernacle and the Temple	ix

THURSDAY, MARCH 12, 1908.

THE FIRST NILE CATARACT.

A Description of the First or Aswan Cataract of the Nile. By Dr. John Ball. Pp. 121; with 13 maps and plates, and 20 illustrations in the text. (Cairo: National Printing Department, 1907.) Price 200 milliemmes.

AMONG the numerous valuable memoirs that have issued from the Egyptian Survey Department under the energetic administration of Captain Lyons, none is likely to prove of greater general interest to the public than this work of Dr. Ball. The easy accessibility of Aswan to visitors sojourning at Cairo, the wealth of objects of antiquarian interest in its neighbourhood, and the existence of that great engineering feat—the Nile dam—ensure the result of a constantly increasing stream of tourists to the district; and although the English, German and French guide-books to Egypt, published by Murray, Baedeker and Hachette respectively, have such a well-deserved reputation, yet the complete topographical and geological survey of the district, made by so competent an official as the author, has enabled him to supply many precise data and new observations not hitherto accessible to the writers of these guide-books. Dr. Ball, indeed, comes with excellent qualifications to the task before him; a good geologist, with special knowledge of petrography, he is at the same time skilled in surveying and engineering matters, while the account which he gives of the literature bearing on the district (pp. 15–20) shows that he has not been unmindful of the importance of this branch of knowledge in connection with a country having such a past as Egypt.

At the outset, the author has to correct the popular misconceptions concerning the nature of the Nile "cataracts." He writes:—

"There is nothing about a Nile cataract in any way resembling Niagara, nor even the Falls of the Rhine at Schaffhausen. The total fall of the water-surface at the First Cataract (between Philæ and Elephantine) is only about 5 metres in a length of about 9 kilometres; and although the greater part of the fall is concentrated within a fraction of this total length, it is only sufficient to give rise to rapids, and not to a waterfall in the ordinary sense of the term. The obstruction to navigation offered by a Nile cataract is in fact due, not so much to the velocity of the water, as to the irregularity and conflicting nature of the currents caused by the narrowness, winding nature and rocky state of the channels."

Aswan was always a place of great importance. Under its ancient name of "Syene," it is constantly mentioned by the writers of antiquity, including the prophet Ezekiel, and many of the Greek and Roman authors. It formed the limit between Egypt and Ethiopia (Nubia), and observations made on the shadows cast by gnomons erected at Syene and Alexandria respectively were employed by the early geographers in determining the size of the earth and the obliquity of the ecliptic. Although Syene was regarded as situated on the tropic of the Cancer, yet

as Dr. Ball points out, Aswan is really $37^{\circ} 37''$ (71 kilometres) north of the tropic; and the period at which, by the secular variation of the obliquity, the site of Aswan coincided with the tropic was about 3500 B.C. Besides the gnomon, there were deep vertical wells sunk at Syene, the bottoms of which were illuminated by the sun at midday at the summer solstice. These wells are mentioned by many ancient writers, including the geographers Strabo, Pliny, and Ptolemy.

The geological survey of this very interesting district was, of course, facilitated by the numerous excavations made during the construction of the great dam. But, on the other hand, the non-existence of any accurate topographical map of the district presented a difficulty which could only be got over by a complete survey of the whole area round the cataract. The line laid out for the dam by the engineers afforded Dr. Ball an excellent base-line, and from this a network of triangles was measured with a good theodolite, the details being filled in with sufficient accuracy by means of the plane-table. Heights were measured from the mean Nile level by the theodolite. This map, which is in six sheets, is a great improvement on any previous one, and has been issued by the Survey Department, its scale being $\frac{1}{100,000}$, but a reduced copy forms plate i. of the work before us.

The geological formations present in the district as shown by the geological map (plate ii.) are:—

(3) Recent deposits, including those formed by the wind (desert sands) and those deposited by the river (Nile muds and sands).

(2) Nubian sandstones and clays, which cap many of the hills.

(1) Metamorphic and igneous rocks, constituting the foundation of the whole country.

The observations of the author on the chemical composition of the Nile muds and sands, and on the nature and form of the mineral particles present in them, are of great value and interest, and are illustrated by some excellent drawings, reproduced in colotype in plate iii. It appears both from recent analyses made in Cairo, as well as from the earlier work of Hofmann, that the Nile-sands contain only small amounts of the hydrated aluminium silicates (kaolin, &c.), but consist mainly of finely comminuted feldspars and other minerals, but little altered.

The work of the geological survey seems to have demonstrated that the Nubian sandstones in this district are wholly of Cretaceous age, although in the Sinaitic Peninsula there are Carboniferous sandstones of very similar appearance.

In opposition also to earlier statements made to the contrary, it is shown that the igneous intrusions are confined to the metamorphic rocks and that they are all older than the Nubian sandstone.

Aswan, or Syene, is of interest to petrologists from the circumstance that a large and important class of rocks derives its name from this locality. The name "Syenite" was first applied to the granitic rocks which were so familiar to the ancients from the circumstance that they were the materials of the great Egyptian monoliths (obelisks, statues, &c.). In 1788,

Werner restricted the use of the term by making the hornblende-orthoclase rock of the Planenschen-grund, near Dresden, the type of the class; and now geologists are agreed in retaining the term for rocks with granitic structure but of intermediate composition, containing little or no free quartz, and having orthoclase as their predominant feldspar. Rocks of this class do occur at Aswan, as shown by Dr. Ball, but they appear to be in all cases subordinate to the true granites with which they are associated.

The chief rocks quarried at Aswan, both in ancient times and also recently, for the construction of the dam, are these granites, sometimes coarse-grained and porphyritic, at other times fine-grained. Both hornblende varieties and types of these rocks rich in mica occur, and by the diminution of proportion of the quartz and the increase in abundance of the subordinate plagioclase, the rocks pass locally by insensible gradations into syenites and diorites.

Full descriptions with excellent figures (plates iv. to xi.) are given by Dr. Ball, not only of these plutonic types, but also of the various metamorphic rocks, and of the rocks that form dykes cutting through both metamorphic and plutonic masses. The survey has, of course, given the author abundant opportunities for collecting specimens, of which he has made ample use. Like Prof. Bonney, who examined a series of the Aswan rocks collected by the late Principal Dawson in 1886, Dr. Ball is struck with the general resemblance of the metamorphic and igneous rocks, both of Upper Egypt and the Sinaitic area, to the Archæan rocks of North America, and he suggests that they may not improbably be of the same great antiquity. The crushing and faulting of these rocks with the intrusion of various dykes took place, the author of this memoir argues, at a date long subsequent to their formation, and this action continued quite down to Cretaceous times, when the Nubian sandstone was deposited quite unconformably on their greatly denuded surfaces. Near the cataract of Aswan no remains of the Eocene clays and limestones, found in other parts of Upper Egypt, occur—they have probably been removed by denudation. Subsequently to the Eocene period, there has been elevation and great denudation. At this period of elevation most of the faults which play such an important part, as shown in this memoir, in producing the general features of the cataract area were formed. By the denudation the older metamorphic and igneous rocks were exposed, and the escarpments and outliers of Nubian sandstone formed.

In the concluding pages of this interesting memoir the author adduces evidence to show that the ancient course of the Nile lay in a broad valley east of the present river, and he discusses the problem of the causes which have led to important changes in the course of the river and the effects of these changes on the character of the country. We must wait for the extension of the geological survey of Egypt, to districts which at present remain untouched, for a full solution of these problems. It is interesting to learn that, although the site of the great Nile dam was determined prior to the execution of the geological

survey, Dr. Ball is of opinion that the line actually chosen for it was a satisfactory one, and that the results of the survey do not indicate that any better site could have been selected for it; and, further, that the straight form, finally adopted for the dam, has been at least equally successful in avoiding the difficulties presented by crushed and decayed rocks as would the curved form originally suggested.

J. W. J.

THE "HISTOIRE INTIME" OF NITROUS OXIDE.

Das Lachgas: eine chemisch-kultur-historische Studie.

By Prof. Ernst Cohen. Pp. iv+99. (Leipzig: W. Engelmann, 1907.) Price 3.60 marks.

IF ABITUÉS of the Royal Institution, and especially those who have interested themselves in its early history, are aware of the existence of a characteristically coarse caricature of Gillray's entitled "Scientific Researches! New Discoveries in Pneumatics! Or an Experimental Lecture on the Powers of Air," which first appeared in 1802, and is stated by Wright and Evans, who published in 1851 a descriptive account of Gillray's cartoons, to represent Dr. Garnett, the first professor of chemistry in the Royal Institution, administering, with the aid of his assistant, Humphry Davy, what is presumably laughing-gas to Sir John C. Hipplesey, a noted patron of the Institution and prominent as a manager, with results disquieting to his "internal economy," and disastrous to "That garment 'twere rude to do more than allude to," as Thomas Ingoldsby says.

This print is hardly so rare as Prof. Cohen would seem to imply, and it has already done duty in connection with the early history of the Royal Institution. It—or rather what Prof. Cohen styles the *right* half of it—is reproduced in Thorpe's biographical account of Davy, published some years ago by Messrs. Cassell. Prof. Cohen, apparently on the sole authority of Pietet, who visited London in 1801, and contrary to all contemporary evidence and the testimony of the editors of Gillray's works, inclines to the opinion that the person administering the nitrous oxide is Thomas Young, who is styled professor of chemistry in the Royal Institution, a position he never held. Of course, a caricaturist like Gillray, who allowed himself unlimited licence, and was bound by no rules either of decorum or probability, might, in portraying a wholly imaginary incident, commit any anachronism he pleased. But there was no reason at the moment why Gillray should be guilty of the anachronism of putting Young into a position he never occupied, since Garnett was the actual professor of chemistry when Davy was assistant, and the humour of the incident—such as it is—is in no wise dependent upon what lecturer is behind the table. Pietet was certainly present at a symposium on a certain Saturday evening at the Royal Institution in the early summer of 1801, when, to quote from a letter from Davy to his friend King at Bristol, "there was respiration, nitrous oxide, and unbounded applause. To-morrow, a party of philosophers meet at the Institution to inhale the joy-inspiring gas. It has produced a great sensation

—*Ca ira*." It was no doubt this "great sensation" that provoked Gillray's cartoon.

But who the lecturer may be would be a matter of small importance except for the circumstance that Prof. Cohen devotes much of his space to a somewhat laboured commentary on the print.

The caricature constitutes, in fact, as he explains in his preface, the *motif* of his little book—a fascimile reproduction of it is given as the frontispiece—and it was the chief inducement which led him to put together at such length the *histoire intime* of laughing-gas.

Such a book is probably not intended to be a serious contribution to historical chemistry. From the fact that it is dated from Zandvoort-Bad in the August of last year—that "summer of drear and dour, implacable rain"—we incline to the opinion that it was a holiday occupation imposed by the tedium of a particularly dolorous time.

With the aid of much "process work" and a wealth of classical allusion, Dr. Cohen has managed to pack within the compass of 100 pages the results of a considerable amount of bibliographical research on matters of no very great importance. Like the famous Cid Hamet, he is the most diligent searcher after the minutest circumstances, "even to the very atoms of his true history," and everything relating to laughing-gas—at least as regards its *histoire intime*—is set down with the most painstaking particularity. The history opens with Mitchill in America and his "oxide of Septon," passes on to Beddoes of Bristol and his Pneumatic Institution; the engagement there of Davy, and his discovery of the physiological effect of the respiration of nitrous oxide, which he prepared by the decomposition of ammonium nitrate in the manner first described by Berthollet and La Place, and, apparently independently, by Deiman and Paets van Troostwijk. There is, of course, no reason why chemistry should not have its Captain Gronow or its Greville memoirs, and, incidentally, Prof. Cohen has much to say of the personal history of certain of those whose names are connected, however slightly, with the *histoire intime* of nitrous oxide. The manner, for example, in which he runs his countryman Adriaan Paets van Troostwijk to earth is characteristic of your born commentator.

Davy's rhapsodical description of his sensations on breathing nitrous oxide is naturally given at length. Next we have a series of portraits, with here and there slight personal touches, of distinguished individuals who have breathed nitrous oxide, or who have seen others breathe it. They range from Southey and Coleridge in England to Fourcroy, Vauquelin, Thénard, Orfila, and Proust in France, and Pfaff and Wurzer in Germany. Indeed, the wealth of pictorial illustration of the *histoire intime* of nitrous oxide which Dr. Cohen's industry and perseverance have enabled him to accumulate is quite remarkable. The only omission we have been able to discover is a representation of a dentist's chair.

Davy's connection with the place, together with Gillray's caricature, is, of course, the main reason

why Prof. Cohen devotes so much of his space to the early history of the Royal Institution, which *pace* Gillray and the symposium already referred to had very little to do with laughing-gas. To what extent the gas entered into its history may be seen from Pictet's lively account, published in 1802. Dr. Cohen, as becomes the true commentator, displays much erudition and no small amount of acumen in expounding the true inwardness of Gillray's drawing. The meaning is not very cryptic, after all. According to our author, the caricature must be regarded as directed against Rumford; it is, in fact, a satire on the Count, and incidentally on the Institution which he founded. Possibly this surmise is true, but the manner in which it is reached is even more humorous than the cartoon itself. So far as we are aware, no one has been at the pains to put forward any other interpretation—certainly none which would conflict with the view which Prof. Cohen has taken, and we are therefore content to be of his opinion, since 'tisn't worth while, it would seem, to dispute, when we know the result immaterial."

We congratulate Prof. Cohen on his interesting brochure. It is an elaborate trifle which may serve to beguile and amuse the tired researcher in his hours of ease. But if the *histoire intime* of chemical compounds, in general, say even of such things as arsenic, prussic acid, calomel or Epsom salts, were to become fashionable, what a literature we should have!

TRITUBERCULISM.

Evolution of Mammalian Molar Teeth, to and from the Triangular Type. (Biological Studies and Addresses, vol. i.) By H. F. Osborn; edited by W. K. Gregory. Pp. ix+250; illustrated. (New York: The Macmillan Co.; London: Macmillan and Co., Ltd., 1907.)

A QUARTER of a century ago next April, the late Prof. E. D. Cope, struck by the remarkable fact that the molar teeth, both upper and lower, of all the mammals from the Puerco or lowest Eocene horizon of North America carry three cusps arranged in triangular form, proposed what was practically the germ of the now well-known tritubercular theory. Briefly stated, this theory is to the effect that in the ancestors of all existing mammals each upper molar carried a triangle of cusps with the apex pointing inwards, while the corresponding lower teeth had a similar triangle with the apex directed outwards; and that from this primitive type have been evolved all the various modifications of molar structure, in most cases by the addition, but in certain instances by the subtraction, of cusps. The exponent, and to a great degree author, of the theory in its present form is Prof. Osborn, who has done well in laying before the scientific world the evidence for and against this fascinating doctrine.

For it has to be acknowledged that while the tritubercular theory was received with acclamation when first promulgated in its full development by the author of the volume now before us, there has of late years been a certain reaction in this respect as the result

of hostile criticism and alternative hypotheses furnished by anatomists and microscopists of great scientific repute. Prof. Osborn is, however, fully convinced of the ultimate triumph of the theory; and, indeed, goes so far as to state that, in his opinion, "the evidence in favour of it is so overwhelming that primitive tritubercularity is no longer an hypothesis or a theory, but an established fact."

That a theory, although established on what appears to be a firm basis of fact, may require revision in certain details is a matter of everyday experience, and our author is fully prepared to admit such emendations in this particular case so soon as the necessity can be proved to be imperative. One of the points against which criticism has been concentrated is the author's view that the apex of the triangle in both the upper and the lower molars represents the single cone of the ancestral reptilian tooth. In the case of the lower teeth, embryological evidence coincides with Prof. Osborn's theoretical view; but as regards the upper molars the testimony of embryology points to the conclusion that, at least in many groups, the antero-external, in place of the internal, is the primitive element. The author meets this and other objections by the candid statement that the five great principles on which the theory was originally based "do not stand or fall together"; one or more may go, or have to be modified, without imperilling the hypothesis as a whole; and even if the cusps ultimately prove not to be strictly homologous with one another in different groups, "the homological nomenclature should be retained for convenience because it has found its way so largely into literature."

The homology and origin of the cusps are, however, by no means the sole object of attack on the part of critics. Among other objections, reference may be made to the multitubercular theory, according to which molars have tended to simplify rather than to grow more complex. This hypothesis is met by the author, and we think rightly, with a direct negative, and certain other objections receive equally summary treatment.

As regards the plan of the work, it is important to notice that the contents are in the main formed by separate papers on tritubercularism, which have been arranged in chronological order, and, where necessary, brought up to date by intercalary notes. This plan has its advantages and disadvantages. Its advantages are that the history of the controversy is easy to follow, while the disadvantages are manifest in the shape of a considerable amount of repetition. We are also left in doubt at the end of the volume as to what the author's present views really are with regard to several points on which his theory has been challenged.

To do anything like justice to the work demands much more space than can be given to it in this notice. All that can be done is therefore to direct attention to its importance and interest, and at the same time to express the opinion that the author has succeeded in placing tritubercularism on a much more secure and unassailable basis than it ever previously occupied.

R. L.

OUR BOOK SHELF.

Nature and Development of Plants. By C. C. Curtis. Pp. v+471. (New York: Henry Holt and Co., 1907.)

The author of this book has set himself a definite task, namely, to give an account of plant life, with special reference to that aspect which presents it as a working organism. Dr. Curtis is to be congratulated on the success with which he has achieved his object, for he has produced an excellent and readable book which may be confidently recommended for the use of junior classes in this country. Naturally, some of the actual examples may prove unfamiliar to the student, but the majority of the plants chosen for illustration are readily accessible to all.

The "nature of the plants" occupies the first part of the book, and it is this portion which strikes us as especially good. The second part is devoted to the development, meaning thereby the phylogenetic classification of the vegetable kingdom; and here again Dr. Curtis has, we think, contrived to sustain the interest in a branch of botany which, as treated in elementary works, is often intolerably dull. He has introduced a certain amount of advanced work in this part of the book, though with a judicious absence of unnecessary detail.

Perhaps a degree of emphasis, rather greater than is warranted by our knowledge, is laid on the relation between alternation of generations and chromosome reduction. The discussion also as to the meaning of unit characters and the method of their inheritance strikes us as too formal and dogmatic to be very useful. But these are small blemishes in a work where there is so much that merits praise.

The numerous and excellent illustrations form a distinct feature of the book, but we note two amongst them which might well be replaced. Fig. 43, and the text which accompanies it, represent a very diagrammatic and not very normal mode of secondary thickening, whilst Fig. 85 certainly ought to be redrawn. A seedling castor-oil plant is not the furry object there represented.

J. B. F.

The Diseases of Animals. By Nelson S. Mayo. Third edition. (New York: The Macmillan Company; London: Macmillan and Co., Ltd., 1907.) Price 6s. 6d. net.

This work, which purports to be one of popular advice on the care and common ailments of farm animals, is written entirely from the American point of view, and deals with American methods principally, in most distinctly American orthography. It cannot be doubted that its usefulness to the British rural public, not less than the pleasure of reading it, are considerably lessened thereby. It is decidedly irritating to readers on this side of the Atlantic to see such abominations as "sulfur," "esophagus," "sulfate," "mold," and others of a similar kind. There is, nevertheless, a good deal of useful and practical information on the care of animals and farm stock which the farmer would do well to know, no matter in what part of the world he carries on his occupation. In fact, that portion of the book which deals with feeding, watering, exercise, and the hygienic care of domestic animals, both stock and pets, is in our opinion by far the most useful to the general reader. In this section dogs, cats, rabbits, hares, guinea-pigs, and poultry are dealt with, in addition to the farm animals proper.

The photographic illustrations of the animals themselves are good, but some of those representing morbid conditions are of little value, for example, that of tuberculosis of the lung (p. 380), which could give no assistance to the non-expert.

In a work of this kind it is doubtless difficult to

deal satisfactorily with the pathological side, and it is a question whether such morbid processes as those of tumours would not be better omitted. In any case, we cannot agree with such statements as:—"True cancers are not common to animals," and, further, that cancers "are most frequent on the head and lower part of the legs." In the section on tuberculosis, the author is satisfied to leave the question of the identity or otherwise of human and bovine tubercle with Koch's original statement of non-communicability, ignoring all that has been done on the subject since that statement was made. Some other conditions, for example, rickets, are very inadequately described.

So far as this country is concerned, there is still room for a good up-to-date popular scientific work which will give the farmer such simple knowledge of the breeding, accidents, and diseases of his animals as will show him the occasion and the wisdom of consulting the skilled veterinarian. G. L.

Traité de Chimie analytique qualitative, suivi de Tables systématiques pour l'Analyse minérale. By Louis Duparc and Alfred Monnier. Second edition. Pp. viii+374. (Paris: Félix Alcan; Geneva: Librairie Kundig, 1908.)

The first edition of this book on analytical chemistry appeared in 1900. In the present, second, edition there has been added a preliminary theoretical portion with the object of giving an insight into the reactions which take place during the analytical operations; this new portion gives an account of the atomic theory, the theory of solutions, and the theory of chemical equilibrium. Then follows the usual description of apparatus, reagents, and methods of manipulation. The main portion of the book is occupied by an enumeration of the reactions of the bases and acids, including the more common organic acids, and more briefly of the rare metals and alkaloids. In each case the reactions which take place are expressed by chemical equations. The book is intended to be a laboratory companion and work of reference not only for the student but also for the analytical chemist. Its value, however, for reference purposes is much lessened by the want of an index, though a full table of contents is given at the end of the volume.

Actualités scientifiques. By Max de Nansouty. Pp. 316. (Paris: Schleicher Frères, 1907.) Price 3.50 francs.

This volume is the fourth issue of an interesting and useful annual publication which on previous occasions we have commended to the notice of science students. Now that ability to read French is expected of science graduates in the University of London, books which provide means for a student to enlarge his vocabulary and at the same time to improve his knowledge of science should be very popular. The selection of subjects is very wide; e.g. articles are included on colour photography, the extraction of gold from the sea, spontaneous combustion, laughing, and artificial flowers.

(1) *California and the Californians.* Pp. 48. (2) *The Alps of King-Kern Divide.* Pp. 22. By President D. S. Jordan, Stanford University. (San Francisco: A. M. Robertson, 1907.)

THESE are two readable essays, the first of which appeared in the *Atlantic Monthly* ten years ago, while the other is reprinted from "Out West." The booklets should be read by visitors to California, and they may be commended also to the general reader, to whom the excellent illustrations will be an interesting feature.

LETTERS TO THE EDITOR.

[The Editor does not hold himself responsible for opinions expressed by his correspondents. Neither can he undertake to return, or to correspond with the writers of, rejected manuscripts intended for this or any other part of NATURE. No notice is taken of anonymous communications.]

The Isothermal Layer of the Atmosphere.

THOSE who, like myself, have followed with interest, but at a distance, the attempts made during recent years to obtain direct information as to the meteorological conditions of the upper atmosphere, cannot but have felt a curiosity on some points which Mr. Dines's letter in *NATURE* of February 27 serves to deepen. To one who has had experience of the vagaries of self-recording instruments, the first question that suggests itself is what degree of reliance can be placed on the results obtained during individual ascents, whether of kites or of balloons. Supposing a temperature of -70° F. recorded, the total range of temperature between the ground and the "isothermal layer" will usually have exceeded 100° F.; thus a 3 per cent. or 4 per cent. error in the scale—an amount not infrequently exceeded in ordinary thermographs limited to ordinary surface temperatures—would suffice to give an uncertainty of 3° F. or 4° F., which seems all that Mr. Dines is prepared to allow. But, apart from mere scale errors, is it certain that there are no other sources of uncertainty in meteorograph records from kites or balloons even when these are sent up after nightfall?

Before attempting to explain such large differences as Mr. Dines mentions between the temperatures in the "isothermal layer," shown by meteorographs sent up on the same day from stations only a few hundred miles apart, one would like to know exactly what the evidence is that the temperatures recorded differ at most only 3° F. or 4° F. from the true ones. The following questions naturally suggest themselves:—

(1) Are the instruments tested over the whole range encountered in the atmosphere, both before and after an ascent?

(2) Has it been a frequent practice to send up two or more thermographs with the same balloon, or with separate balloons, but at the same station and at the same time, and if so, have they always given closely accordant results?

(3) Has it been established by actual trial that the different types of meteorographs, English and foreign, when sent up at the same time from the same station, give a satisfactory agreement?

Mr. Dines mentions a case when the temperatures found for the "isothermal layer" at three English stations on the same day varied from -42° F. to -74° F. An uncertainty of $\pm 4^{\circ}$ F. could account for only a quarter of this, but an uncertainty of $\pm 8^{\circ}$ F. might account for a half, and an uncertainty of $\pm 16^{\circ}$ F. for the whole. Now is there conclusive evidence that uncertainties of the order $\pm 16^{\circ}$ F. are quite out of the question?

March 3.

CHARLES CHREE.

The Solidification of Helium.

IN the telegram from Prof. Kamerlingh Onnes announcing the solidification of helium, the statement is made that "the last evaporating parts show considerable vapour pressures as if liquid state is jumped over"—in other words, it apparently sublimates.

I have for a long time expected that this would be the case. When the boiling points and melting points of the non-valent elements are plotted against their atomic weights the curves nearly meet, the two points for argon being very near to one another. By a slight extrapolation they may be made to meet, and they then do so for an atomic weight much higher than that of helium. Now if an element corresponded to the meeting point its triple point would be given by the temperature at the join. Elements of lower atomic weight would sublime instead of melting. This is apparently the case for helium, and it is a moot point whether or not it will be found to be also so for neon. The uncertainty arises from the rapid drop in the curves in passing to the row of elements N, O, F, to which neon belongs. Each curve can be represented very nearly by a parabola.

ALFRED W. PORTER.

University College, London, March 6.

Disease-resisting Sugar-canes.

It is observed in your issue for November 7 last in the article entitled "Immunity to Disease among Plants," being an abstract of a letter delivered before the British Pharmaceutical Conference at Manchester by Prof. F. E. Weiss, that the following statement occurs:—

"In the West Indies, the Bourbon cane has been given up on account of disease, but very useful and disease-resisting hybrids have been produced by crossing the valuable but easily attacked Tjeribon cane with the resistant Indian Tschan cane."

The latter canes are not known in the West Indies, and it is desirable, therefore, that the actual facts be placed on record.

When the Bourbon sugar-cane had to be abandoned in the West Indies on account of its susceptibility to fungus disease, its place was generally taken by the White Transparent—an introduced variety. Since then the latter is being largely replaced by seedling canes. These seedlings have been produced in some instances from the Bourbon cane, and, recently, almost entirely from the better of the newer seedling varieties under experiment. It may be of interest to mention that in British Guiana the area under cultivation with varieties of sugar-cane other than Bourbon is about 30,000 acres, and the greater portion of this area is occupied by seedling canes. In the island of St. Kitts about 71 per cent. of the sugar-cane acreage is occupied by seedlings. Seedling canes are also being largely planted at Barbados, Antigua, St. Lucia, and Jamaica. Many of the newer seedlings appear to be immune to some of the fungus diseases that affect the sugar-cane in these colonies, and the efforts in the direction of producing seedling canes by artificial cross-pollination give promise of success.

In Java the circumstances are also somewhat similar. The Cheribon cane had to be abandoned on account of its being liable to the "serah" disease, and amongst the foreign varieties introduced to take its place was the East Indian cane Chunnee. In 1894 it was found that the Cheribon cane bore a large proportion of infertile pollen with a normal ovary, while the Chunnee produced a very large quantity of fertile pollen. Advantage was taken of this to plant the two varieties side by side in the hope of producing hybrids by natural means. Considerable success has been attained, for a very large number of seedlings was obtained by sowing seeds from the "self-sterile" arrows of the Cheribon, many of which combine the high sugar content of the Cheribon with the disease-resisting power of the Chunnee. Other introduced canes have also been used in these experiments, and somewhat similar experiments are in progress in the West Indies.

A résumé of the "Improvement of the Sugar-cane by Selection and Hybridisation" (with coloured plates) was presented by Mr. F. A. Stockdale and myself at the conference on genetics held in London in August, 1906, under the auspices of the Royal Horticultural Society. The society issued a full report of the conference in February, 1907. The paper referred to has since been reproduced in the *West Indian Bulletin* (vol. vii., No. 4).
Barbados, February 14.

D. MORRIS.

Modern Views of Electricity.

To avoid misunderstanding, I write to say briefly, in connection with a review by "N. R. C." on p. viii of the supplement to NATURE of March 5, that I have never supposed space to be a conductor, but have always taught the opposite view; and that I have never imagined unmodified ether to be subject to gravitation, or to be other than the vehicle of that property of matter. If any phrases in my book suggest the contrary they are examples of faulty expression. But I would add, parenthetically, that I should not scruple to speak, untechnically, of the centre of gravity of a surface.

OLIVER LODGE.

Rothsay Summers and Greenwich Winters.

Last summer at Rothsay (N.B.) was very wet, with 14.8 inches (average, 11.3 inches). The current winter season at Greenwich may now be pronounced a mild one.

It is a curious fact (whatever the explanation) that a very wet summer at Rothsay tends to be followed by a mild winter at Greenwich, and a very dry summer by a severe winter. This is connected, I believe, with the fact that the rainfall of Scotland and the winter cold of Greenwich both exhibit pretty clearly the influence of the sun-spot cycle.

Suppose we pick out the twenty-two wettest and the twenty-two driest summers at Rothsay in the sixty-six years 1841-1906 (i.e. a third in either case). The former group range from 19.1 inches down to 12.6 inches; the latter from 5.9 inches up to 10.7 inches. Next, consider what sort of winter at Greenwich followed each of these (say, how many frost days in the period September to May).

These winters may be represented as in diagrams A and

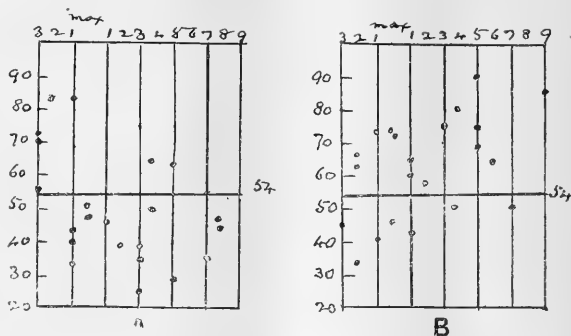

The scale of frost days at Greenwich is shown on the left, and that of the sun-spot cycle at top of each diagram. A, Winters after very wet summers. B, Winters after very dry summers.

B, where a dot indicates by its position both the number of frost days of one winter and its position in the sun-spot cycle.

It will be seen that the twenty-two "very wet" Rothsay summers were followed by fifteen mild and seven severe winters at Greenwich (A), and the twenty-two "very dry" Rothsay summers by fifteen severe and seven mild winters at Greenwich (B). The contrast is still more pronounced if we confine attention to the period of decline of the sun-spots.

These diagrams seem to warrant two practical rules, which may be thus stated:—

During decline of the sun-spots, if summer rainfall at Rothsay exceeds 12.6 inches, a mild winter at Greenwich is highly probable (say, 6 to 1), and if during the same period the Rothsay summer rainfall is under 10.7 inches a severe winter is highly probable (say, 3 to 1). In the former case a very severe winter, and in the latter a very mild winter, would seem to be excluded.

We are at present close to a maximum (1905 or 1907?), and have to do with diagram A, which shows no severe winters for the corresponding position in the cycle.

ALEX. B. MACDOWALL.

The Possibility of Life in Mars.

At the risk of being thought by your correspondent, Mr. C. O. Bartrum, an "anthropomorphist," I consider that Prof. Lowell in his admirable investigations of the markings of Mars is quite reasonable in ascribing the change of colour to the presence of a vegetation containing a substance allied to, if not identical with, chlorophyll. I do so because the spectroscopic has shown that, not only the solar system, but the whole universe, is built up of inorganic elements similar to those found on the earth. If we find unity of plan pervading the structure of the most

distant stars, surely it is not beyond credibility to assume that the organic worlds may have a like relationship to each other when other circumstances are favourable.

Hove, March 3.

W. AINSLIE HOLLIS.

The α Particles from Radio-active Substances.

The experiments of Rutherford and Hahn have shown that the ratio e/m has the same value, 5×10^8 , for α rays, no matter from what source the rays are derived. They are, however, taken alone, incapable of deciding whether the particles are hydrogen molecules carrying the usual ionic charge, or helium atoms with twice that charge. In a recent paper in Roy. Soc. Proc., Prof. Townsend has shown that the positive ion produced by Röntgen rays has twice the ionic charge at the moment of formation. If his further experiments prove this true generally, then the question whether the α rays are hydrogen or helium must be definitely decided in favour of the latter, and the association of this gas with radio-active substances is accounted for.

R. S. WILLOWS.

Cass Institute, E.C.

ANCIENT EGYPTIAN BURIAL CUSTOMS.¹

WE have had to wait some little while for Prof. Garstang's publication of his discoveries in the necropolis of Beni Hasan during the years 1902-3-4. However, "better late than never."

The publication is issued under the auspices of the University of Liverpool, in which Mr. Garstang now professes the methods and practice of archaeology. We must congratulate Prof. Garstang on his appointment. As a professional excavator of untiring industry and "go," he has been known to the archaeological world for some years; and he has been a lucky excavator also. Nobody knows better than the digger that luck, no less than a keen eye and "sense of the probable," knowledge of the appearance of disturbed and undisturbed land, &c., is an important ally to him; and the discoverer of the other half of the Menes tablet at Nagada should gratefully admit his obligations to Dame Fortuna.

No such stroke of luck marked the excavations at Beni Hasan. The results were all what might have been expected and predicted of a necropolis of the eleventh and twelfth dynasties. Except for a few more than usually elaborate models and some very fine cartonnage mummy-coverings of a type not previously noted, they are not new. As always in tombs of this date, we have little but the rectangular coffins and models of workmen, slaves, boats with their crews, granaries, and so forth, which are well known in our museums. A large number of tombs was discovered, and the number of objects found in them was enormous. How to publish this huge mass of material, mostly of types already well known, was a difficult question.

To publish everything scientifically, in the manner of the Egypt Exploration Fund, would have been a most expensive task, as well as (since the antiquities found are mostly of a kind well known already) an unnecessary one. A scientific publication of similar type, but containing only the most important finds, would have been the expedient which most archaeologists would have adopted. Prof. Garstang has, however, chosen rather to adopt a novel plan; he has written simply a description of the burial customs of the Egyptians under the Middle Kingdom, illustrated by typical examples of the objects found at Beni Hasan. Whether this decision was wise or

not it is difficult to say. As a matter of personal opinion, the other alternative of a modified publication on the lines of one of the annual volumes of the Egypt Exploration Fund would seem preferable. The result of Prof. Garstang's decision is that we have here a book which is at once a more or less popular work on the burial customs of ancient Egypt, but only deals with this subject in part, and a scientific report of the results of the excavations at Beni Hasan which is of unhandy form, and is written and illustrated in an inconvenient way. The book is too heavy as well as too expensive for a popular treatise, while for a scientific work the larger format of the Fund's publications is infinitely preferable. The treatment of the subject-matter is too general and scrappy for a scientific report, and the illustrations, being scattered throughout the text instead of concentrated in plates, may be appropriately arranged for a popular book, but are most ill designed for reference by the scientific student. On the whole, we think Prof. Garstang's decision unfortunate, and we hope that in future he will publish his discoveries in the admirable manner of his former publications, with their large, thin format and groups of plates at intervals throughout the volume. Let him keep his strictly scientific publica-

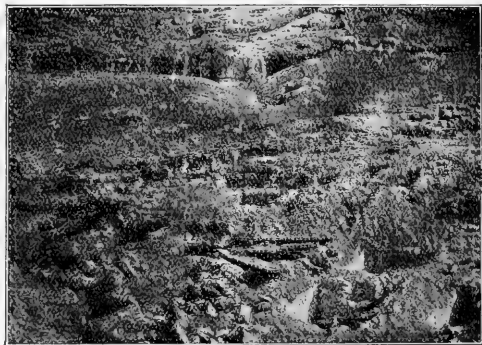

FIG. 1.—Position of the Pit Tombs below the Gallery.

tions and his *œuvres de vulgarisation* entirely apart. A popular book from his pen on the burial customs of ancient Egypt which should really cover the whole subject would be most welcome.

In spite of its defects, however, the present volume is a most interesting contribution to archaeological literature. As specimens of the admirable photographs with which it is illustrated, we here reproduce in Fig. 1 a view showing the position of the pit-tombs excavated by Prof. Garstang in relation to the gallery-tombs of the princes of Beni Hasan, which are so well known to every visitor to Egypt; in Fig. 2 a view of the interior of a tomb as discovered and after removing the *débris*, which shows how the coffins and models of boats, &c., are found, and incidentally shows how thorough Prof. Garstang's archaeological methods are in respect of complete photographic recording; and Fig. 3, a model of a group of two officers playing draughts on board ship, showing the cabin against which are propped their great shields and arrow-cases. This is a very interesting specimen of the numberless models found, which give us so complete an idea of what the

¹ "Burial Customs of Ancient Egypt." By Prof. J. Garstang. Pp. xv+250. (London: A. Constable and Co., Ltd., 1907.) Price 12. 12s. 6d. net.

Egyptians looked like in the third millennium B.C. Of no other people at so remote an age do we know so much, and we may well bless that pious care for the

to pursue an independent path as a painter. This is to be regretted from the point of view of archaeology, as Mr. Jones would, as his work with Prof. Garstang has shown, have been a valuable recruit to the ranks of the excavators.
H. R. HALL.

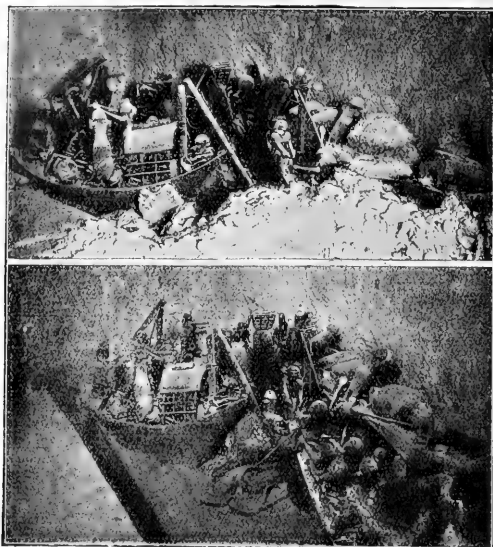
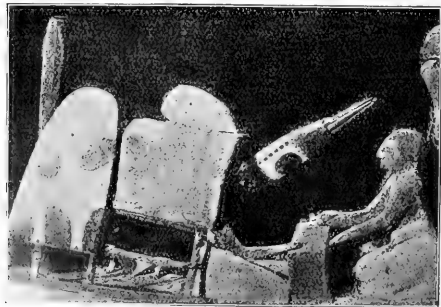

FIG. 2.—(a) Interior of Tomb as discovered. (b) The same after removing the Débris.

ancient dead which provided them with these little representations of their life on earth.

Very few slips of any kind have crept into the text, but we notice one on p. 169, in which it is said that the names of the vases and other offerings painted on the coffins illustrated in Fig. 171 "are given in difficult hieratic writing." The names shown are in linear hieroglyphics, and are quite easy to read. The



—Officers playing Draughts on board ship. Model from a Tomb.

unworthy photograph in the book is Fig. 4, in which the cliffs illustrated are by no means clear.

At the end of his preface, Prof. Garstang says that the name of Mr. Harold Jones, is now leaving him.

SLEEPING SICKNESS.¹

WHEN the campaign against malaria was commenced, our knowledge of the parasitic agent of that disease was practically complete, and in no essential particular has our knowledge of the mode of transmission changed since the discovery of the anopheline-malarial cycle. But when we consider sleeping sickness the matter is very different. Our knowledge of trypanosomes is even yet in its infancy. It has, for instance, been asserted over and over again that sexual differences exist in trypanosomes, and on this basis have been constructed developmental cycles which indeed may exist, but in proof of which the evidence hitherto adduced has been practically nil; and indeed two of the latest observers, Moore and Breinl, not only find no evidence of this sexual difference, at least in the blood, but describe two new phases of trypanosomes, viz. a so-called minute latent form, which comes into existence mainly when the ordinary forms from one cause or another have disappeared from the peripheral circulation, and resistant cystic forms, which appear when an animal is treated with atoxyl.

We have, according to these authors, a cycle of the trypanosome going on in the body hitherto unsuspected, and we also have encystment of trypanosomes under injurious influences. If this be true, it shows that, unlike malaria, we know but little of the complete life-cycle of trypanosomes, for of these forms we know so far only of their bare existence.

This discovery, then, opens the whole question of the life-cycle of trypanosomes, including the question also whether there are sexual forms or no. There are further questions which are equally obscure. While, in the case of malaria, shortly after the discovery of the all-essential importance of some of the anophelines in its transmission close attention was paid to the habits of these mosquitoes, in the case of tsetse-flies we know about their habits comparatively little. It is perhaps an exaggeration to say that we know now no more about tsetse-flies than we did when Bruce discovered that *Gl. morsitans* transmitted the trypanosome (*T. brucei*) of ngana, but at any rate we can sum up in a few words what we know of the habits of the fly:—(1) The only place so far discovered where the tsetse deposit their larvæ has been among the roots of banana-trees; (2) they haunt the scrub or bush along the margins of lakes and rivers, and are seldom found far from water. The reason for this distribution is unknown, though one might conjecture that it has something to do with their food supply. (3) The sources of their food supply are also very imperfectly known. Is blood a necessity for their existence in nature? That they pursue man voraciously is known, but what other animals do they feed on? Koch recently has confirmed the observation that they suck crocodiles' blood, and holds that this is their main if not sole food; and has even gone so far as to suggest that the destruction of crocodiles would cause the disappearance of the fly. The

¹ Proceedings of the First International Conference on the Sleeping Sickness held at London in June, 1907; and further paper respecting the Proceedings of the Conference.

destruction of crocodiles is a comparatively easy matter, as the eggs, sixty or seventy, can be collected from the nests, the sites of which are well known to the native. Possibly, however, aquatic birds would still furnish them with blood. The duration of their life, their breeding habits, the habits of different species, the conditions which give rise to "fly belts," are almost unknown. It is somewhat remarkable that so little is known, although many expeditions have now studied sleeping sickness; the fly, however, has surely been somewhat neglected. One fact of great practical importance has, however, become clear, viz. that clearing the jungle drives away the fly, and to this we shall return. When we consider next the mode by which the fly transmits the disease, we find ourselves in the midst of controversy.

One view is that the transmission is a mechanical one, i.e. the fly carries infection as an inoculating needle from one animal to another, and the known experimental facts entirely support this view; and, further, we have the fact that in Dourine this is the sole (? also by fleas) known method, the mechanical transmission being in this case by sexual intercourse, a method which, according to Koch, also takes place to some extent in sleeping sickness. Another view, that a developmental cycle goes on in the fly, is based mainly on analogy and on the alleged existence of sexual forms of trypanosomes in the blood, and more especially in the gut, of flies. We will not enter here into the wilderness of arguments, but point out the following facts. The tsetse used for experimental purposes have hitherto, almost without exception, been caught in nature, consequently, *ex hypothesi*, some of them must contain the trypanosome in the required hypothetical developmental stage. These flies have then been fed on infected animals, and it was found that when now fed on fresh animals the latter only became eventually infected if the period that elapsed since the last feeding on infected animals was not longer than forty-eight hours, a fact explained on the mechanical view by the statement that after this time no longer can trypanosomes be found in the proboscis. Now, if these flies, on the contrary, contained a developmental stage of trypanosome, this result is inexplicable except on one hypothesis, viz. that during the feeding on infected animals (an unnecessary procedure on this view) the flies completely get rid of all trypanosomes in the necessary developmental stages in their salivary glands (?) by the preliminary feeding on the infected animals. This objection could be met by keeping flies caught in nature for forty-eight hours more or less. If now they are capable of infecting fresh animals it would be in favour of the developmental view and against the mechanical one; if not capable of infecting it would negative the developmental view, provided, of course, sufficient experiments were made to allow for experimental error, &c.

We might point out in this connection a possible explanation of the difficulties encountered by some observers in obtaining positive results in transmission experiments. In the case of anophelines caught actually in native huts where the inmates were highly infected with malaria, we have ourselves in certain instances found only 3 per cent. of the anophelines infected with parasites, a remarkably low figure. Had these anophelines been caught in cow-houses, where they often abound, we consider that it would have been possible to dissect thousands and find none infected. Now, in the case of tsetse-flies, they are not found in houses, but live in the open, so that unless the flies have bitten man they will not become infected with the trypanosome (unless, indeed, they have bitten some other unknown host), and if the flies used in these experiments are collected from parts of the bush where they have not bitten man

(or other host of the trypanosome), it would be quite conceivable that thousands of flies might be used in transmission experiments with negative result, and even if they had an opportunity of biting man it is still conceivable that the number of infected ones might be very small if we consider the fact of the low figure of 3 per cent. for infected anophelines found by us in certain highly malarious districts.

If we consider the matter from another standpoint we see that again our knowledge is wanting. What is the source of the *T. gambiense*? Is it purely a man-to-man infection, as we believe to be the case in malaria, or can the fly convey the trypanosome to man from various animals? This would seem to be likely, for experimentally the fly has been proved to transmit to monkeys, so that there seems to be no *a priori* reason against thinking that the flies can transmit not only from man to man, but from man to animals and from animals to man. If this is so (but arguments can be brought against this view), then it has an important bearing on the results of isolation of the sick, for the remaining healthy population may be still living amidst infected animals, domestic and wild.

In cattle in the Congo, in sleeping-sickness areas, it is believed that the trypanosome is a different one, viz. *T. dimorphon*. Even if other reservoirs of *T. gambiense* exist, it must be admitted that the removal of the sick would remove one important source of infection, whatever proportion these bear to other reservoirs (if existent) of *T. gambiense*.

We should consider, then, that this is perhaps the most important point which requires immediate solution, and it can be determined only by a long series of laboratory inoculations.

A further point for decision, as we have seen, is the mode of transmission, mechanical or developmental, or both. This, perhaps, is of scientific rather than of immediate practical importance. Thirdly, we require a careful extended study of the habits of the fly.

But although much investigation remains to be done, we may now briefly recount what is being carried out in the light of our present knowledge.

Sleeping sickness can be detected in its early stages, first, by the enlargement of glands, e.g. those in the neck, an almost constant phenomenon (and the glands on puncture show trypanosomes); and, secondly, by the method recently used by Koch of examining fairly thick stained blood films on several occasions. We have thus means at our disposal of detecting early cases even when the person is to all outward appearances healthy.

(1) *Isolation*.—The removal of infected persons so far as possible to localities free from the fly, where they may be suitably treated, is certainly imperative.

(2) *Inspection posts*.—The spread of the disease to non-infected areas where the fly exists by means of infected persons should be controlled so far as possible by medical examination at inspection posts along the main routes of traffic. Although no doubt some will escape detection, yet the method is one which enables us largely to control the spread of the disease.

(3) *Treatment of the sick*.—We have in atoxyl an arsenic compound first introduced by Thomas and Breinl, undoubtedly the best drug hitherto used in combating the disease. Undoubtedly cases of sleeping sickness in Europeans have been cured by it, and lately Koch, in an extended trial of the drug, has spoken in laudatory terms of its use. He recommends the giving of half-gram doses on two consecutive days at intervals of ten days, and continuing the treatment for long periods. The method is slightly different from that advocated by the Liverpool School of Tropical Medicine when it first distributed atoxyl throughout the Congo, but Koch has

only modified the dosage, and he adds his testimony to the great value of the drug.

This method, should nothing supersede it, will thus become almost as valuable as that of quinine in the treatment of malaria. In Koch's words, "Daraus geht doch aber mit aller Bestimmtheit hervor, dass durch eine geeignete Atoxylbehandlung sehr vielen Schlafkranken, das Leben gerettet werden kann."

(4) *Destruction of tsetse-flies*.—This, so far as we know at present, is not directly practicable, but the flies can be driven away by cutting the jungle. The making of clearings where the natives most frequent, such as at watering places, river fords, and around villages, will certainly be beneficial.

For the present, then, we have at our disposal methods the results of which we shall soon learn. In conclusion, it is, I think, certain that when some of the disputed points indicated above are settled the campaign against the disease will be carried out with greater efficiency because based on more certain knowledge. J. W. W. S.

WATER VAPOUR IN THE MARTIAN ATMOSPHERE.

ONE of the most telling arguments which has been used against the possibility of the planet Mars being habitable has been that spectroscopists have failed to detect with certainty the presence of water vapour in the planet's atmosphere. It now seems probable that this objection will have to be abandoned, for, in a telegram recently received by Sir Norman Lockyer, Prof. Lowell announces that Mr. Slipher has got on repeated plates—specially prepared for this research—the water vapour bands a and near D stronger in the spectrum of Mars than in that of the moon at the same altitude.

Should Prof. Lowell's further researches confirm it, this result is one of the most important links in the remarkable chain of evidence for a habitable Mars. The photography of the canals was a great step forward, but the presence of these features was unconvincing unless it could be proved that the water to fill them in their proper seasons was available. Similarly, the seasonal increase and decrease in the dimensions of the snow-caps were thought to be conclusive evidence for the presence of water until the frozen carbon dioxide theory was advanced, although this theory left unexplained the ill-defined edges of the disappearing snowfields. But, so far as our present knowledge goes, it is difficult to see how carbon dioxide is able to produce the intensification of the water-vapour bands in the spectrum of the planet's atmosphere.

For many years, in fact since the actual existence of permanent features on the planet's surface was established, this question of water vapour—of the existence of a substance capable of producing clouds and mists—has been one of the chief points of contention among areographers. So far back as 1863 Sir Norman Lockyer, in a communication to the Royal Astronomical Society (*Memoirs*, vol. xxxii., p. 179, 1863), describing his observations of Mars during the opposition of 1862, stated that "although the complete fixity of the main features of the planet has been thus placed beyond all doubt, daily—nay, hourly—changes in the detail and in the tones of the different parts of the planet, both light and dark, occur. These changes are, I doubt not, caused by the transit of clouds over the different features." The drawings accompanying the memoir illustrated the changes mentioned, and confirmed the suspicions of cloud effects noticed by Secchi in 1858. But the

assumption that these effects were caused by clouds and mists entailed the assumption of the presence of water vapour in the planet's atmosphere, and the spectroscopic evidence for this has hitherto been too indefinite. Suspected by Huggins and Vogel in 1867 and 1873 respectively, its presence was negatived by the subsequent spectroscopic researches of Campbell and Keeler, but now it appears certain, from this latest result from the Lowell Observatory, that water vapour is one of the concomitants of the Martian atmosphere.

In his recent book, "Is Mars Habitable?" reviewed by Dr. Lockyer in NATURE for February 13 (p. 337), Dr. Russel Wallace insisted on the absence of spectroscopic evidence as a strong argument against the presence of water vapour. This objection is now removed, and once more it becomes reasonable to suppose that the Martian surface is, at least to some extent, supplied with that compound which, to terrestrial minds, is one of the essentials of habitability. At the same time, the theories advanced by Prof. Lowell to explain the remarkable variety of appearances and changes from season to season, disclosed by his wonderful observations, have received support worthy of their brilliant conceptions.

WILLIAM E. ROLSTON.

NOTES.

IN an announcement in last week's NATURE it was stated that Prof. Kamerlingh Onnes had succeeded in liquefying helium. It should have been stated that the gas was solidified, no intermediate liquid stage being observed. The demonstration was made in the presence of Prof. H. A. Lorentz and Prof. J. P. Kuenen, both of the University of Leyden. The method adopted is described by the Leyden correspondent of the *Daily Telegraph* (March 10) as follows, and is the same as that used with success by both Sir James Dewar and Prof. Olszewski. The only noteworthy point is the large amount of helium used for the instantaneous expansion. "To make this experiment," Prof. Onnes says, "I placed a tube with thick sides, containing a thinner one for extra protection against external warming influences, in a vessel filled with liquid hydrogen, at -43° F., and in this tube about one and a half gallon of helium was compressed under 100 atmospheres. On allowing expansion to a lower temperature a cloud appeared, which increased as the expansion *in vacuo* continued. Out of the nebulous mass a white flocculent substance gathered in the inner tube, where—although the tube was well closed—it evaporated within twenty seconds. Some solid substance, however, was left, the pressure in the tube meanwhile rising to one atmosphere, and when the valve was opened the pressure was reduced this substance exhaled almost immediately, no sign of liquefaction being observable. The substance which remained at a temperature of -43° F. was solid helium." We are glad to be able to print the telegraphic message sent to Sir James Dewar by Prof. Onnes on March 5, and Sir James Dewar's reply to it:—Prof. Onnes to Sir James Dewar, Royal Institution, London: "Converted helium into solid. Last evaporating parts show considerable vapour pressures, as if liquid state is jumped over." Sir James Dewar to Prof. Onnes, University, Leyden: "Congratulations. Glad my anticipation of the possibility of the achievement by known methods confirmed. My helium work arrested by ill-health, but hope to continue later on."

The council of the British Association has nominated Prof. J. J. Thomson, F.R.S., as president of the association for the meeting to be held next year in Winnipeg,

and Prof. Thomson has accepted the invitation to occupy that office.

The third congress of experimental psychology will be held at Frankfurt on April 22-25.

WE deeply regret to announce that Dr. H. C. Sorby, F.R.S., died at Sheffield on Monday, March 9, at eighty-one years of age.

PROF. E. RUTHERFORD, F.R.S., has been awarded the Bressa prize of 9600 lire (384*l.*) by the Turin Academy of Sciences.

PROF. H. POINCARÉ, professor of mathematical astronomy in the University of Paris, has been elected a member of the French Academy.

PROF. W. S. HANDLEY will deliver the Hunterian lecture on "The Natural Cure of Cancer" at the Royal College of Surgeons to-morrow, Friday, March 13, at 5 p.m.

A REUTER message from Melbourne reports the death on March 8, at seventy-seven years of age, of Dr. A. W. Howitt, C.M.G., author of "The Native Tribes of South-East Australia" and other important anthropological works.

A CELEBRATION of the jubilee of the presentation of the Darwin-Wallace joint essay to the Linnean Society on July 1, 1858, will take place on July 1 next; the details are not complete, but it is intended that an afternoon meeting and an evening reception shall take place on the day named, with the award of copies of a special medal, and subsequent publication of the proceedings of the celebration.

THE steamer *Nimrod*, of Lieut. Shackleton's Antarctic expedition, has returned to Christchurch, New Zealand, from the Antarctic. The *Nimrod* is expected to return to the Antarctic next January to fetch the expedition, and she should be back in England some time in the later part of 1909. The *Daily Mail* of March 7 contains a narrative of the expedition, so far as it has gone, by the leader, Lieut. Shackleton.

THE President of the Local Government Board has authorised for the current year the following researches, in addition to those already announced, under the grant voted by Parliament in aid of scientific investigations concerning the causes and processes of disease:—(1) further studies by Drs. Andrewes and Horder as to methods of inhibiting in the animal body the activities of infection by certain cocci; (2) a study of the various forms of pneumonia, especially in children, by Mr. Foulerton; (3) a study of acid-fast bacilli in butter, by Dr. Nabarro; (4) an investigation of the injurious gases evolved during artificial illumination, by Dr. J. Wade.

REUTER'S Agency states that the second International Conference on Sleeping Sickness met on Monday at the Foreign Office. It is understood that the chief business of the conference will be the discussion of a draft general Act dealing with measures for combating the disease which has already been drawn up by the British Government and submitted to the various countries represented at the conference. There is further to be discussed a counter-draft Act prepared by the German Government which contains some slight modification of the British proposals. The complete list of delegates of the seven countries represented at the conference is as follows:—*Germany*: Dr. Robert Koch, Herr H. de Jacobs, Dr. Steudel; *Spain*: the Marquis de Villalobar, Dr. F. Murillo Palacios; *Congo*

Free State: Colonel Lantonnois, Dr. van Campenhout; *France*: M. Le Myre de Vilers, M. Ronssin, Dr. Kermorgant, Dr. Cureau, Dr. Giard; *Great Britain*: Lord Fitzmaurice, Sir W. Foster, M.P., Mr. A. W. Clarke, Mr. H. J. Read, C.M.G., Sir Patrick Manson, Dr. Rose Bradford, F.R.S., Sir R. Boyce, F.R.S., Colonel D. Bruce, C.B., F.R.S.; *Italy*: Prof. Rocco Santoliquido, Prof. Adolfo Cotta; *Portugal*: Dr. Ayres Kopke. The Lord Mayor will entertain the president and delegates of the conference at luncheon at the Mansion House on Monday next, March 16.

WE regret to read in Tuesday's *Times* that Dr. W. E. Wilson, F.R.S., died on Friday last, March 6, at fifty-six years of age. For many years Dr. Wilson gave disinterested and devoted attachment to research in astronomy and physics, and his work secured for him a high place among scientific investigators. In December, 1870, he was engaged on the total solar eclipse expedition to Oram, and in 1872 he built an astronomical observatory at Daramona, Ireland, and equipped it with a 12-inch reflector by Grubb. Nine years later this was superseded by a more completely equipped observatory containing a fine reflecting telescope of 2 feet aperture, with mounting of the most modern design. In 1891 this was re-mounted and provided with electric control for astronomical photography. With this instrument Dr. Wilson obtained some remarkable photographs of celestial objects, including the moon and many nebulae and stellar clusters. In later years a physical laboratory and mechanical workshop were added to the astronomical observatory, and in the laboratory many important researches on radiant heat and light were carried on by him. Among the subjects of his papers read before various scientific societies are "Experimental Investigations on the Effective Radiation from the Sun." Other important publications of his are entitled "The Absorption of Heat in the Solar Atmosphere," "The Temperature of the Carbons in the Electric Arc," "The Effect of Pressure of the Surrounding Gas on the Temperature of the Crater of the Electric Arc," "The Thermal Radiation from Sun-spots," and "Radiation from a Perfect Radiator." His papers published before the year 1900 were issued separately in a volume entitled "Astronomical and Physical Researches made at Mr. Wilson's Observatory, Daramona, Westmeath," in which appear reproductions of some of his celestial photographs. Dr. Wilson's scientific work was recognised by his election as a Fellow of the Royal Society in 1896, and by the degree of Doctor of Science conferred on him, *honoris causa*, by Dublin University a few years later.

By the untimely death, at the age of sixty-one, of Sir Denzil Ibbetson, India has lost one of her most eminent anthropologists. He joined the Punjab Civil Service in 1870, and his remarkable report on the revision of settlement in the district of Karnal, situated in the south-east of the province, led to his appointment as superintendent of the census of the province in 1881. The report on Karnal was a remarkable achievement. It was based upon a profound knowledge of the peasant classes, their mode of life, social institutions, and religious beliefs. Students of the rural classes in northern India had long been aware that their religion was to be found, not, as the Max Müller school contended, in the sacred books recorded in Sanskrit, a language familiar only to a few Pundits, but in the cults and beliefs connected with the worship of the rural "goddings," as Ibbetson designated them. But the case for this novel view of Indian popular religion was now for the first time clearly advocated in

attractive literary form, and from intimate, personal knowledge. These conclusions were repeated and extended in his census report of 1881, which, in addition to admirable chapters on peasant religion, contained a singularly elaborate account of Hindu and Mussulman castes, tribes, and sects. The weak point of the investigation was that it was purely ethnographical, and ignored the physical characteristics of the people, a subject of which the writer possessed no knowledge. This report, of which the chapters on religion and caste were reprinted in 1883 under the title of "Outlines of Panjab Ethnography," forms an excellent manual of the subject. Additions to the information contained in it have, it is true, been made in the later census reports of Messrs. E. D. MacLagan and H. A. Rose, but the substantial accuracy of Ibbetson's work remains unaffected. His reports suggested and inspired the investigations on similar lines conducted by Sir H. Risley in Bengal, by Mr. W. Crooke in the United Provinces of Agra and Oudh, and by Mr. E. Thurston in Madras. The Punjab Government would be well advised to re-publish, as the best memorial of the late Lieutenant-Governor, the reports on which his reputation as an anthropologist will mainly depend.

A FURTHER contribution to the mass of literature relating to the Mexican cotton-boll weevil is made in Bulletin No. 73 of the Entomological Bureau of the U.S. Department of Agriculture, in which Mr. W. D. Price discusses the numerous parasites preying upon that beetle.

WE have received a copy of the forty-first report of the Peabody Museum of American Archaeology and Ethnology at Harvard, in which special attention is directed to an expedition recently sent to South America to procure collections. The expedition, which has been well received by the officials of the various districts visited, has already secured valuable specimens and data.

IN the eighth quarterly report on the scientific work of the Lancashire and Western Sea-Fisheries District, Prof. Herdman announces that, owing to his absence on a visit to the Ceylon pearl-oyster fisheries, the publication of the annual sea-fishes laboratory report will be delayed for a short period beyond the usual date. Plankton will form a considerable item in that report; while of more general interest will be an account, by Mr. J. Pearson, of all that can be ascertained with regard to the life-history and economic value of the edible crab.

BULLETIN No. 50 of the Agricultural Experiment Station at Storrs, Connecticut, is devoted to the rearing of young pigeons—"squabs" as they are locally called—for the market. It is generally supposed that this industry is one which can be profitably undertaken by any person with no previous experience, but this the author—Mr. C. K. Graham—shows to be an altogether mistaken idea. In a properly managed establishment each pair of pigeons ought to produce on an average five pairs of squabs annually; only a few produce more than seven pairs, and in one case where eleven were brought forth none of these were reared to maturity.

THE February issue (vol. ii., No. 4) of the *Journal of Economic Biology* is devoted to the parasitic insects of the Chermes and Coccus groups, Mr. E. R. Burdon discussing the European members of the former genus, while Mr. R. Newstead describes three species belonging to the same family as the latter found on cocoa, rubber, and other plants in western Africa. In the case of Chermes, it is stated that much investigation is still required with

regard to the life-history of the European species, some of which present puzzling problems in connection with their migrations and the "intermediate hosts" they affect during their developmental cycles. The second paper deals mainly with structural details.

To the fiftieth volume, part iii., of the Smithsonian Miscellaneous Contributions, Mr. Bruno Müller contributes a long and elaborate paper on the air-sacs of pigeons, based on an investigation undertaken for the purpose of finally setting at rest the disputed question as to the function of these structures in birds generally. The author refuses to accept any one of the theories hitherto proposed, and comes to the conclusion that the air-sacs, together with the air-cavities in bones, are not to be regarded as organs with any special function, but rather as a system of empty interspaces. "Their value lies in their emptiness, that is, in their containing nothing that offers resistance or has an appreciable weight. Flying is the highest form of locomotion, and as such only possible to a body of high mechanical efficiency. Our most effective machines are by no means compact and solid, but composed of parts as strong as possible in themselves and arranged in the most appropriate manner. The interspaces between the parts are left empty and taken up by air. The Sauropsida, at the time they obtained the power of flight, became adapted to its mechanical requirements, and thereby similar to the efficient machines mentioned above; they divested themselves of all superfluous material, filling the body-space thus obtained with air sacs."

IN No. 29 of the Scientific Memoirs of the Government of India, Captain Christophers, I.M.S., discusses the disease of dogs due to the protozoan parasite *Piroplasma canis*. The symptomatology of the disease, the morphology of the parasite, and its transmission by the tick *R. sanguineus*, are fully described, and the developmental cycle of *P. canis* in the tick detailed. In the tick the parasite becomes a club-shaped body, then a zygote which breaks up into sporoblasts, and these again into sporozoites. A full bibliography of piroplasmosis in general is appended, and the memoir is illustrated with diagrams and two plates. In Memoir No. 30 of the same series, Captain Harvey, I.M.S., and Captain McKendrick, I.M.S., discuss the theory and practice of antirabic immunisation, and conclude that the methods of Höyges and of Ferrans, in which fresh material is used, present certain advantages over those in which dried or heated material is employed for purposes of antirabic immunisation.

THE geographical variation in birds, with especial reference to the effects of climatic humidity, forms the subject of a paper by Mr. C. W. Beebe in the first number of a new serial issued by the New York Zoological Society. Unfortunately, the cover and title-page are lettered *Zoologia*, whereas, as we learn from an erratum-slip, the designation should be *Zoologica*. The serial is published by the society at New York, the first number being dated September 25, 1907. Mr. Beebe attaches great importance to the effects of humidity in producing local phases in particular species, and refers to the well-known fact that while hot, damp situations tend to melanism, dry, sandy localities are equally favourable to the production of light tints. One of the most marked instances of this occurs in the pigeons of the genus *Scardafella* when kept in captivity in a warm, humid atmosphere. In the typical *S. inca* the whole breast is uniformly pale-coloured, but specimens kept in captivity under the above conditions assume after the first moult the characters of *S. r.*

dialeucos, and after the second those of the Brazilian *S. ridgwayi*, which exhibit a progressive degree of dark marking on the breast. Later on the captive birds develop dark markings unparalleled in any wild species. The author then discusses the bearing of these facts on the recognition of geographical races and species of birds, concluding, if we rightly understand his argument, that such recognition need not on this account be abandoned.

It is a matter of considerable interest to botanists that a new edition of the "Botanist's Directory" is being prepared by Mr. I. Dörfler, of Vienna. The last (second) edition was published in 1902, and owing to the changes that take place in six years is much in need of revision. The care bestowed on the work by the publishers, and the general support accorded by botanists in all parts of the world, render the book authentic and remarkably complete.

DR. S. SCHÖNLAND contributes to the Records of the Albany Museum, vol. ii., part ii., the diagnoses of new species of *Aloe*, *Crassula*, *Cotyledon*, and *Kalanchoe* collected in various South African States. The most singular is *Crassula Engleri*, of which all the flowers examined showed stamens only and no female organs, furnishing evidence of dioecism. The same author is responsible for the first part of a list of flowering plants found in the districts of Albany and Bathurst, Cape Colony, that is supplementary to an earlier enumeration in the Records. A new species of *Gasteria* is recorded.

THE physiology and morphology of some Californian hepatics form the subject of a paper contributed by Mr. H. B. Humphreys to the Proceedings of the Washington Academy of Sciences, vol. x. (January). The author describes an endophytic fungus developing sclerotia that was commonly found in the vegetative parts of plants of *Fossombronina longisetia*. Fungi were also found associated with *Aneura multifida*, *Anthoceros Pearsoni*, and *Porcella bolanderi*. In all these cases there was every indication that the fungus acted as a parasite. Another feature of interest examined was the development of tubers by the *Fossombronina* and two species of *Anthoceros*; these serve to tide the plants over the dry season. The author also investigated the power of plants and spores to resist desiccation. The use of Knop's solution for germinating spores is noteworthy.

A MONOGRAPH on the stem of the flax plant, prepared by Miss T. Tammes, has been published in the *Natuurkundige Verhandelingen van de hollandsche Maatschappij der Wetenschappen*, vol. vi., part iv. Certain problems connected with flax culture, such as the usual practice of importing seed from Russia, the influence of soil, dimensions of the fibres, &c., are discussed. With regard to the origin of the cultivated plant, the author sees no reason to connect it with *Linum angustifolium*, *Linum humile*, or any other wild species. It was found that the length of the fibres, varying on the average between 25 mm. and 40 mm., is greatest in long and thick stems; a maximum length of 120 mm. is recorded. The fibres increase in length from the base of the stem upwards to within a short distance below the fruit.

THE Carnegie Institution of Washington has issued an elaborate research memoir, covering 144 pages, on high steam-pressures in locomotive service, by Mr. W. F. M. Goss. The results apply to practice involving single-expansion locomotives using saturated steam. The results of the tests show that the higher the pressure the smaller the possible gain resulting from a given increment of

pressure. A simple locomotive using saturated steam will render efficient service when the running pressure is as low as 160 lb. No argument is to be found in the economic performance of the engine which can justify the use of pressures greater than 200 lb.

FIVE paleontological contributions to the geology of Western Australia are contained in Bulletin No. 27 of the Geological Survey of that colony. They comprise notes on plant remains from the Collie coalfield by Mr. R. Etheridge, and on fossils from the same coalfield by Mr. F. Chapman, two reports on fossils from the Irwin River coalfield by Mr. R. Etheridge, and a report on the foraminifera from a calcareous marlstone at Gingin by Mr. W. Howchin. They add considerably to the knowledge of the organic remains of the rocks of Western Australia, and two of the contributions throw light upon the vexed question of the geological age of the Collie River Coal-measures, and are of scientific interest in their relation to the important question of the distribution of Glossopteris flora. A re-examination of two leaf fragments, previously thought possibly to belong to the Mesozoic genus *Sagenopteris*, proves them to belong to the Palaeozoic genus *Glossopteris*.

THE occurrence of "black rain" in Ireland on October 8-9, 1907, is reported by Dr. O. Boeddicker in *Symons's Meteorological Magazine* for February. On the afternoon of October 8 a dark cloud approached Birr from the S.E., and "black rain" was reported from several places. A letter addressed by Lord Rosse to the *Irish Times* brought a large number of replies, showing that the fall of soot was greater to the S.E. and E. of Birr than to the N.W.; the deposit was considerable in Westmeath, Meath, and Monaghan, and was also traced to the west of Mayo. The evidence seems to show that the cloud originated in South Wales, crossed the Irish Channel and the whole of Ireland, finally disgoring its soot into the Atlantic Ocean.

IN *Ciel et Terre* of January 1, M. J. Vincent gives an account of the unmanned balloon ascent of July 25, 1907, in which the extraordinary altitude of 26,557 metres was reached. The tandem balloons left Uccle (near Brussels) a few minutes before 7h. a.m. (G.M.T.), wind E.N.E., temperature 12°·1 C. The usual inversion was well shown; at 12,112 metres the fall in the thermometer, which read -57°·0 C. (-70°·6 F.), was arrested, and was succeeded by a sudden rise of 6°·7 C. between that height and 13,591 metres. An isothermal zone was then met with, followed by another rise which slowly brought the reading to -42°·2 at about 8h. 6m. a.m., the time when the upper balloon burst. The ventilation of the thermometer was sufficient during the whole of the ascent. The humidity began to decrease rapidly at 1016 metres, where it was 72, at 1690 metres it was 22, and at 6109 metres it had fallen to 9; it decreased but little after that, the lowest reading being 6. At the time of the inversion the wind changed from S.S.W. to W.; then during the slight inversion which followed up to 26½ kilometres two currents were met with, the lower from S.E. and the upper from E.; on descending, the S.S.E. current was replaced by a southerly wind.

A THOROUGH examination of the relative merits of the radiomicrometer, the linear thermopile, the radiometer, and the bolometer, for the measurement of radiation, has been made by Mr. W. W. Coblentz, of the United States Bureau of Standards, and is published in the January number of the Bulletin. The conclusion arrived at is that the bolometer is the quickest acting of the four, and should

be used in all cases in which there is much variation of the radiation with time. On the other hand, if the source of radiation is constant, the radiometer is the most sensitive, particularly in the infra-red. The radiometer, although capable of improvement, is not likely to reach one-fifth the sensitiveness of the bolometer. The Rubens thermopile, when its heat capacity is diminished by the use of thinner wire, is as sensitive as the bolometer, and is to be recommended for the measurement of very weak radiation on account of its greater steadiness.

ACCORDING to the *résumé* of communications made to the Société française de Physique on February 7, Drs. Hemsalech and de Watteville find the flame spectra of metals extend far into the ultra-violet, and are much richer in lines than they have been thought to be. The method used by the authors is a modification of that originally used by M. Gouy. They obtain the finely divided material to be studied, and mix it with the gases proceeding to the burner, by forming an electric arc between two electrodes of the material placed in a bulb through which one of the gases passes. If two such arcs between different metals are used, the spectra of the two metals are superposed. If the gas is filtered between the arc and the flame the lines are scarcely affected, while the continuous spectrum is very much diminished in intensity.

WE have received from Messrs. John Wheldon and Co. a catalogue of books and papers offered for sale on microscopical science in all its branches, including an important collection of works on Diatomacea.

A CIRCULAR has reached us referring to the issue of publications in connection with the Indian Forest Department. It has been decided that in future the forest literature shall appear in two chief forms, described, respectively, as Indian Forest Records and as Memoirs. In addition to these publications, it is proposed to issue pamphlets and leaflets on professional subjects.

THE Royal Statistical Society has issued a new catalogue, which comprises, with certain exceptions, all works included in the society's library on December 31, 1906. The number of books and separate publications is approximately fifty thousand. The general rules adopted in the compilation of the catalogue are stated with clearness, and statisticians should find the new list a great convenience.

THE Society for Promoting Christian Knowledge proposes to issue the following books on scientific subjects in May next:—"Turbines," by Engineer-Commander A. E. Tompkins, R.N., second edition, enlarged and revised; "Spinning Tops," by Prof. J. Perry, F.R.S., revised edition, with an appendix on the gyrostad and the monorail; "The Fundamental Conceptions of Chemistry," by Prof. S. M. Jorgensen, translated from the latest German edition, with additions by Mr. M. P. Applebey.

OUR ASTRONOMICAL COLUMN.

THE PARALLAX OF THE ANDROMEDA NEBULA.—No. 4, vol. viii., of the *Astronomiska Iakttagelser och Undersökningar å Stockholms Observatorium* is devoted to the results of an investigation of the parallax of the Andromeda nebula. The observations on which the results are based were made in two groups, the first set of fifteen photographs being taken during the period 1902-4, the second,

including forty-seven photographs, covering the season 1904-5. Dr. Karl Böhlén, by whom the investigation has been carried out, describes fully the methods employed, and finds for the parallax of the nebula the definitive value $+0''.171$.

THE ORBIT OF γ VIRGINIS.—A re-investigation of the orbit of γ Virginis has convinced Dr. Doberck that the differences between the calculated and observed positions of that star, when near the periastron passage, are at least partly due to the perturbations to which he recently directed attention. It also seems probable that changes in the shapes of the components, and even explosive action, may exert some influence on the orbit. Dr. Doberck suggests that spectroscopic observations of double stars should prove especially useful in cases where the orbit is very eccentric if made while the companion is close to the principal star. The elements now given show the period of γ Virginis to be 182.30 years, and the eccentricity of the orbit to be 0.88736. The hypothetical parallax is $0''.116$ (*Astronomische Nachrichten*, No. 4235, p. 161, February 29).

THE LARGE SOLAR PROMINENCE OF MAY 21, 1907.—In No. 1, vol. xxvii., of the *Astrophysical Journal* (p. 78, January), Father Fényi compares his visual observations of a large eruptive prominence which he observed at Kalocsa on May 21, 1907, with the photographic observations of the same prominence made by Mr. Fox at the Yerkes Observatory (*NATURE*, p. 90, No. 1987, November 28, 1907). The visual observations give lower altitudes than the photographic, and, on comparing the sketch made at the same time as Mr. Fox's second photograph, it is seen that the forms are so different that no part of them can be identified; on the whole, the sketch more strongly resembles the first photograph made some fifty minutes earlier. The visual observations also show a much quicker ascension of the prominence material than do the simultaneous photographs, the rate being 54 km. per second instead of 30 km.; no change of form was observed visually during the time occupied in observing eleven transits. Father Fényi records that he has never observed the subsidence of a prominence of great height. With prominences of low altitudes the descent of the material is the usual occurrence, but dissipation at great altitudes appears to be the rule for those which attain great heights.

SPANISH OBSERVATIONS OF THE TOTAL SOLAR ECLIPSE OF AUGUST, 1905.—The results of the eclipse observations made at Soria, Spain, in August, 1905, by the members of the eclipse expedition from the Marine Observatory of San Fernando, are embodied in a handsome volume recently published under the direction of Captain Don Tomás de Azcarate, director of the observatory. Numerous photographs of the chromospheric spectrum and of the corona were obtained, and some of them are reproduced in the volume. Nearly five hundred lines were measured in the spectra of the chromosphere, and their wave-lengths are given, together with the probable origins and their wave-lengths as determined by Lockyer, Dyson, Evershed, and other eclipse observers. The volume also contains the results of the meteorological observations made at Soria, and the results of the observations of the contacts, &c., made at San Fernando and many other stations in Spain.

A NEW VARIABLE OF THE U GEMINORUM TYPE.—A telegram from the Kiel Centralstelle announces that the variable star β 1.1907 Aurigæ was observed by Prof. Hartwig on March 6 and found to be of the irregular class, similar to U Geminorum; the magnitude was 9.0.

THE CANADIAN ASTRONOMICAL HANDBOOK FOR 1908.—The second annual handbook published by the Royal Astronomical Society of Canada contains a great deal of information useful to amateur astronomers. Ephemerides and charts for the positions of the major planets, lists of interesting coloured, variable, and double stars, and a calendar of astronomical occurrences for the current year are among the many useful data given, whilst there is also a mass of information more especially useful to Canadian observers.

THE USE OF GYROSTATS.

AT a recent meeting of the Physical Society a model was exhibited which purported to illustrate Mr. Brennan's mono-rail railway. Prof. Perry, president of the society, made the following remarks, which he was afterwards requested to edit and publish:—

In 1874 two famous men made a great mistake in endeavouring to prevent the saloon of a vessel from rolling by using a rapidly rotating wheel. Mr. MacFarlane Gray pointed out the mistake. It is only when the wheel is allowed to precess that it can exercise a steadying effect; the torque or moment which it exerts is equal to the angular speed of precession multiplied by the moment of momentum of the spinning wheel.

It is astonishing how many engineers who know the laws of motion of translation are ignorant of angular motion, and yet the analogies between the two sets of laws are perfectly simple. I have set out these analogies in my book on "Applied Mechanics."

The last of these, between centripetal force on a body moving in a curved path and torque or couple on a body rotating about an axis, is the simple key to all gyrostatic and spinning-top calculations. When the spin of a top is greatly reduced, it is necessary to remember that the total moment of momentum is not about the spinning axis (see my "Applied Mechanics," p. 594). Correction for this, I suppose, what introduces the complexity which scares the students of the subject of the vagaries of tops; but in all cases that are likely to come before an engineer, it would be absurd to study such a correction, and consequently calculation is exceedingly simple.

Inventors using gyrostats have succeeded in doing the following things:—

(1) Keeping the platform of a quick-firing gun level on board ship, however the ship may roll or pitch. Keeping a submarine vessel or flying machine with any plane exactly horizontal or inclined in any specified way. These were probably first described by Mr. Brennan. It is easy to effect such objects as these without the use of a gyrostat. By means of spirit levels it is possible to command powerful electric or other motors to keep anything always level. The actual methods employed by Mr. Beauchamp Tower (an hydraulic method) and by myself (an electric method) depend upon the use of a gyrostat which is really a pendulum, the spinning axis being vertical.

(2) Greatly reducing the rolling or pitching of a ship, or the rolling of a saloon in the ship. This is the problem which Mr. Schlick has solved with great success, at all events in the case of torpedo-boats.

(3) In Mr. Brennan's mono-rail railway, keeping the resultant force due to weight, wind pressure, centrifugal force, &c., exactly in line with the rail, so that however the load on a wagon may alter in position, and although the wagon may be going round a curve, the wagon is quickly brought to a position such that there are no forces tending to alter its angular position. The car leans over towards a sudden gust of wind or towards the centre of curvature if going round a curved rail.

(4) I need not refer to such matters as the use of gyrostats in the correction of compasses on board ship.

Problems (2) and (3) are those to which I wish to refer. It is to be remembered that without gyrostatic apparatus a ship is necessarily stable, a mono-rail wagon is unstable.

Mr. Schlick uses a large wheel of ten or twenty tons revolving about an axis EF (Fig. 1), the mean position of which is vertical. Its bearings are in a frame EFCD, which can move about a thwartship axis CD. Its centre of gravity is below this axis. Let the ship have rolled through the small angle R from its upright position; the axis EF has precessed through the angle P from a vertical position. Let θ stand for d/dt . Let the moment of

momentum of the wheel about its axis be m . Now if the ship were held fast so that she could not roll, we might study the vibratory motion P. The effect of the roll is merely to introduce a term $m\theta R$ increasing P. Thus we have

$$I_1 \theta^2 P + f \theta P - m \theta R + b P = 0. \dots (1)$$

where $f \theta P$ is a fluid friction introduced by dash pots acting at A and B, $b P$ is the righting moment of the frame, and I_1 its moment of inertia about the thwartship axis. Now write out the usual equation of motion of the ship vibrating about a longitudinal axis through its centre of gravity, its moment of inertia being I , but introduce a moment $m \theta P$ tending to diminish R.

Then we have

$$I \theta^2 R + F \theta R + m \theta P + a(R - \alpha) = 0. \dots (2)$$

if $\alpha = a_0 \sin q t$ is the thwartship inclination of the sea to the horizontal, and a is the righting moment of the ship per unit angle, being the weight of the ship multiplied by the metacentric height. $F \theta R$ is the moment due to friction against the sea.

Solving these equations just as if θ were a constant, we have from (1)

$$P = \frac{m \theta R}{I_1 \theta^2 + f \theta + b}$$

so that (2) becomes

$$(I \theta^2 + F \theta + a + \frac{m^2 \theta^2}{I_1 \theta^2 + f \theta + b}) R = a \alpha. \dots (3)$$

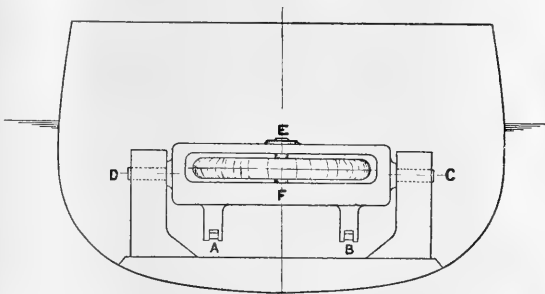

FIG. 1.

Clearing of fractions we find $\{I I_1 \theta^4 + (F I_1 + f I) \theta^3 + (a I_1 + b I + m^2 + F f) \theta^2 + (b F + a f) \theta + a d\} R = (I_1 \theta^2 + f \theta + b) a \alpha. \dots (4)$

Replacing θ^2 by $-q^2$, and θ^4 by q^4 (see my "Calculus for Engineers," p. 237), we can at once express $\frac{R_0}{\alpha_0}$ if R_0 is the amplitude of the roll, and of, course,

$$P_0 = \frac{m \theta R_0}{\sqrt{(b - I_1 q^2)^2 + f^2 q^2}}. \dots (5)$$

I am here studying the forced vibrations, and not the natural vibrations. In any particular case it is quite easy to calculate R_0/α_0 for a number of values of q , and information is obtainable which is quite different from what comes from a study of the natural vibrations (that is, taking $\alpha=0$). Besides, it is the very easiest kind of arithmetical calculation, replacing rather troublesome mathematics. To many, indeed I may say to all students, the calculation of the unreal roots of a biquadratic is troublesome, and this must be done if the natural vibration is to be studied. It is obvious that the real parts of the roots of the resulting equation in R (when α is 0) are negative, and therefore the motion is stable.¹

If, however, we make α of (2) negative, as it is in the

¹ The well known conditions that the real parts of all the roots of $\theta^4 + a \theta^2 + b \theta^2 + c \theta + d = 0$ shall be negative, are that a, b, c , and d shall be positive, and also that $abc - c^2 - a^2 d$ shall be positive.

Brennan case, it will be found that the motion is not stable. Even without friction the vibration would become greater and greater, and friction makes matters worse. Indeed, no form of the Schlick method can be applied to the Brennan waggon. But to return to the ship.

It will be found that the amplitude of P is much greater than that of R, and in practice it is necessary to have stops to prevent P becoming too great. Of course, when further increase of P is prevented by a stop, the roll proceeds as if the wheel were not spinning.

I have not seen it mentioned, but I should think that Mr. Schlick would let his wheel revolve like Mr. Brennan's, in a very perfect vacuum inside a case, because the power wasted in friction of a wheel against an atmosphere is proportional to the density of the atmosphere. I have found that the best shape of wheel is one like a fly-wheel with a thin disc inside the rim instead of arms; there is more moment of momentum per pound to be obtained in this way than by building up a wheel like a compound disc, as a gun is built up of tubes shrunk on; and also it is much better than the form of wheel adopted by Laval in his turbine. I need not say, also, that the moment of momentum per pound of steel is proportional to the radius of the wheel; the greater the radius, therefore, the better.

It is assumed that by the use of bilge keels and rolling chambers, and as low a metacentric height as is allowable, we have already lengthened the time of vibration and damped the roll R as much as possible. Using (2) or (5), we find P if R is known, and usually the quick vibration is much more magnified in P than the slow one.

Let us consider a numerical example. Using engineers' units, let $I = 10^4$, $a = 2 \times 10^3$, $I_1 = 7000$, $b = 70,000$, $m = 2.5 \times 10^4$, and $F = 4 \times 10^4$, and let us find answers to (4) for two values of f . These numbers are nearly right for a vessel of 6000 tons, metacentric height 18 inches, with a natural period of fourteen seconds. Its gyrostat wheel weighs about ten tons, with a 6-feet radius and an angular velocity of 100 radians per second. The frame and wheel have an oscillating period about the axis CD of about two seconds. These answers are compared with the case of the gyrostat not in action, that is, $m=0$, or precession prevented.

If the gyrostat is not in action, it is easy to see that

$$R_0 = a_0 \sqrt{\frac{1}{(1 - \frac{I_1}{I} q^2)^2 + \frac{F^2}{a^2 q^2}}}$$

The natural vibration has a damping term Σ^{-F/d^2} with a periodic time nearly $2\pi \sqrt{\frac{I}{a}}$.

I take F such that the amplitude diminishes by about 25 per cent. in one period (about fourteen seconds). It will be noticed that the F term of the formula (6) is important only near the critical q or $q = 0.4472$. It will be found that the F term in (4) is of insignificant effect.

Again, the values of $\frac{R_0}{a_0}$ get large for large values of q , because there is a quick natural vibration as well as a slow one. I have not thought it worth while to tabulate these higher values.

It is interesting to calculate $P_0 + a_0$ for all values of q , and especially for the larger values of q .

Free Vibration.—Using the above numbers and $a=0$, so that the ship is gradually coming to rest, we are led to

$$R = Ae^{-0.025t} \sin 0.447t \dots \dots \dots (7)$$

if the gyrostat is not acting. This is a periodic time of fourteen seconds, and the damping is such as to reduce the amplitude of roll by 25 per cent. in each complete period.

When the gyrostat is acting and $f=50,000$, we are led to

$$R = Ae^{-0.025t} \sin 0.324t + Be^{-3.573t} \sin (2.519t + c) \dots (8)$$

We may neglect the quick vibrations of 2½ seconds' period, which are damped out very rapidly. The slower have a period of nineteen seconds, the amplitude of roll being diminished by 30 per cent. in every complete period. Note that $P_0 = 50 R_0$ if $q = 2.519$, and $P_0 = 11.3 R_0$ if $q = 0.324$.

When the gyrostat is acting and $f=3 \times 10^5$, or six times as great, we are led to

$$R = Ae^{-0.02t} + Be^{-42.32t} + Ce^{-0.204t} \sin 1.703t \dots (9)$$

so that the slower periodic motion has disappeared, and the quick one, the period of which is nearly 3.7 seconds, is rapidly destroyed. For both (8) and (9) it is interesting and easy to calculate P.

In solving the biquadratics which lead to such answers, let it be noticed that we are led usually to roots $-a \pm \beta i$ and $-m \pm ni$, where $i = \sqrt{-1}$, n and m being much smaller than a and β . If we leave out the last two terms of

$$\theta^4 + a\theta^3 + b\theta^2 + c\theta + d = 0 \dots \dots \dots (10)$$

we get the larger roots, approximately; if we leave out the first two terms we may not get m , but we get a good approximation to n , and it is n which it is most important to know. The following is a quick method of finding the roots with any amount of accuracy that is required. We know that

$$\begin{aligned} a &= 2(a + m), \\ b - a^2 + \beta^2 + m^2 + n^2 + 4am, \\ c &= 2m(a^2 + \beta^2) + 2a(m^2 + n^2), \\ d &= (a^2 + \beta^2)(m^2 + n^2). \end{aligned}$$

The numerical example given above, where $f=5 \times 10^4$, requires us to solve

$$\theta^4 + 7.16\theta^3 + 19.42\theta^2 + 1.83\theta + 2 = 0.$$

First assume that $m=0$, so that $a=3.58$. We see then that the sum of $a^2 + \beta^2$ and $m^2 + n^2$ is 19.42, and their product is 2, so that we can find them.

$$\begin{aligned} a^2 + \beta^2 + m^2 + n^2 + 2 &= 0 \\ \text{gives } a^2 + \beta^2 &= 19.42, m^2 + n^2 = 0.103. \\ \text{Then } 0.915 \text{ or } \frac{1}{2}c &= 19.42m + 3.58 \times 0.103 \\ \text{or } m &= 0.0282. \end{aligned}$$

Secondly assume that $m=0.0282$, so that $a=3.5519$; taking $a^2 + \beta^2 + m^2 + n^2 + 2 = 0$ we get $a^2 + \beta^2 = 19.02$; $m^2 + n^2 = 0.10515$, $\frac{1}{2}c = 0.915 = 19.02m + 3.553 \times 0.105$ gives $m = 0.0285$.

Assuming m to have this value, we may proceed to a third calculation. In this way we get closer and closer to the true value of m , and therefore to the true values of a , β , and n . In practice I find that the two calculations such as I give here are sufficient.

It may be taken as roughly true from (4) that the effective moment of inertia of the ship is increased from I to $I + \frac{m^2}{\omega^2}$, so that the time of a slow vibration is multiplied by

$$(1 + m^2/Ib)^{\frac{1}{2}}$$

If all ships and their gear are similar, it will be found that m^2/Ib is inversely proportional to the dimensions. Thus if a 100-ton boat has its period increased by 50 per cent., then a perfectly similar ship of 2700 tons will have its period lengthened by only 19 per cent.

It may be, however, that the proportions should be different in vessels of different size, and it is not fair without further experience to make a comparison which seems so unfavourable to the method. Besides, experience alone can show how the dash-pot friction may depend

Γ	q	Values of R_0/a_0		
		Gyrostat not acting	Gyrostat acting	
			$f=5 \times 10^4$	$f=5 \times 10^4$
63.0	0.01	1.0	1.0	1.0
63	0.1	1.05	1.1	1.1
31.5	0.2	1.25	1.61	1.32
21	0.3	1.82	5.57	2.77
14	0.4	4.64	1.96	1.75
10.5	0.4472	11.10		
7.5	0.5	3.71	0.76	0.73
5.25	0.55	1.92		
4.5	0.6	1.25	0.55	0.351

upon the size of the ship. Probably, too, large ships may be regarded as being steady enough already.

If we apply the Schlick method to Mr. Brennan's car, as a of (4) (putting $\alpha=0$) is negative, there is instability of motion whether there is or is not friction. We may,

The car is supported by a mono-rail bogie at each end; each bogie has two wheels pivoted vertically and horizontally, so that curves may be very sharp and the ground may be uneven.

Fig. 3 is a



FIG. 2.

however, do as the exhibitor of the model (at the Physical Society meeting) has done—make b also negative. That is, make the gyrostat frame unstable by having the centre of gravity of the frame EAB above the axis DG. In this case, if there is absolutely no friction either of the f or F kind, there will be steady vibrations about a mean position, but any friction will cause the swings to get larger and larger. It is to be noticed that even without friction there will be instability if m , the moment of momentum of the fly-wheel, is less than a certain amount. Fig. 2 shows his model car (about 6 feet long). It is driven by electric accumulators carried by the car. His gyrostat wheels are driven by electromotors, not shown in Fig. 3; as they are revolving in nearly vacuum spaces they consume but little power, and even if the current were stopped they would continue running at a sufficiently high speed to be effective for a length of time.

It will be found that energy is wasted by friction, and also work has to be done in bringing the car to a new position of equilibrium, and all this is supplied by the electromotors. Should the gyrostat really stop or reach a certain low speed, two supports are automatically dropped, one on either side of the car; each of them drops until it reaches the ground, one of them dropping perhaps much farther than the other.

The real full-size car which Mr. Brennan is now constructing may be pulled with other cars by any kind of locomotive, using electricity or steam or petrol, or each of its wheels may be a driving wheel. He would prefer to generate electric power on his train, and to drive every wheel with an electromotor. His wheels are so independent of one another that they can take very sharp curves and vertical inequalities of the rail. The rail is fastened to sleepers lying on ground that may have sidelong slope. The model car runs on an iron gas-pipe; the ground is nowhere levelled or cut, and at one place the rail is a steel wire rope spanning a gorge (Fig. 2). It is interesting to stop the car in the middle of this rope and to swing the rope sidewise, watching the perfect automatic balancing. The car may with confidence be left here for hours, balancing itself with nobody in charge. If the load on the car—great lead weights—be dumped about into new positions, the car effects balance with no apparent effort. But if, the car not running but merely balancing itself, a person standing on the ground pushes against it, the car will push in opposition, and by pushing judiciously a person can really disturb the car's vertical position considerably; it is as if an indignant animal were resisting the push. Left to itself now, the car quickly rights itself.

diagrammatic representation of Mr. Brennan's pair of gyrostats in sectional elevation and plan. The cases G and G' , inside which the wheels F and F' are rotating in *vacuo* at the same speed and in opposite directions (driven by electromotors not shown in the figure), are pivoted about vertical axes EJ and $E'J'$. They are connected by spur-toothed segments JJ and $J'J'$, so that their precessional motions are equal and opposite. The whole system is pivoted about C , a longitudinal axis. Thus when precessing so that H comes out of the paper, so will H' , and when H goes into the paper, so does H' .

When the car is in equilibrium the axes KH and $K'H'$ are in line NN' across the car in the plane of the paper. They are also in a nearly horizontal line which is at right angles to the total resultant force on the car. I will call this the mid-position.

Let lm be the moment of momentum of either wheel. Let us suppose the car to tilt so that the shelf D comes up against H , the spinning axis (or a roller driven by

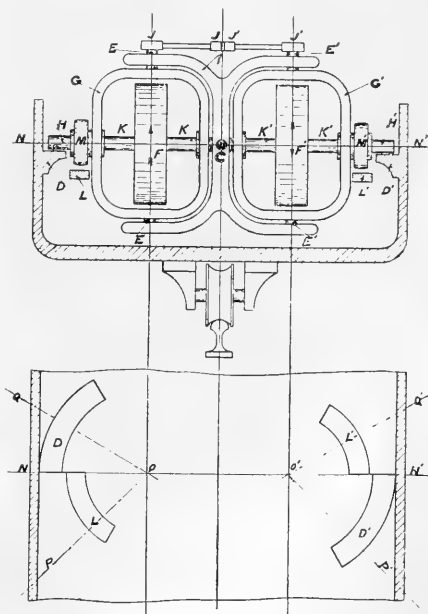

FIG. 3.

the spinning axis) of the gyrostat. H begins to roll away from me, and if no slipping occurred (but there is always slipping, and, indeed, slipping is a necessary condition) it would roll, that is, the gyrostats would precess with a

constant angular velocity, α , exerting the moment ma upon the shelf D, and therefore on the car.¹

This precession continues until the roller and the shelf cease to touch. At first H lifts with the shelf, and afterwards the shelf moves downwards, followed for some distance by the roller. If the tilt had been in the opposite direction, the shelf D would have acted upon the roller H', and caused just the opposite kind of precession, and a moment of the opposite kind.

We now have the spindles out of their mid-positions as OO', O'Q'. How are they brought back to NOO'N' with H permanently lowered?

It is the essence of Mr. Brennan's invention that, after a restoring moment has been applied to the car, the spindles shall go back to the position NOO'N' with H permanently lowered, so as to be ready to act again.

He effects this object in various ways. Some ways described in his patents are quite different from what is used on the model, and the method to be used on the full-size wagon will again be quite different. I will describe one of these methods. Mr. Brennan tells me that he considers this old method to be crude, but he is naturally unwilling to allow me to publish his latest method.

D' is a circular shelf extending from the mid-position in my direction; D is a similar shelf extending from the mid-position into the paper or away from me. It is on these shelves that H' and H roll, causing precession, as I have just described. When H' is inside the paper or when H is outside the paper they find no shelf to roll upon. There are, however, two other shelves, L and L', for two other rollers, M and M', which are attached to the frames concentric with the spindles. They are free to rotate, but are not rotated by the spindles. When they are pressed by their shelves L or L' this causes negative precession, and they roll towards the NOO'N' position. There is, of course, friction at their supports retarding their rotation, and therefore the precession. The important thing to remember is that H and H' when they touch their shelves (when one is touching, the other is not touching) cause a precession away from the mid-position at a rate which produces a restoring moment ma of constant amount (except for slipping), whereas when M or M' touches its shelf L or L' (when one is touching the other is not touching), the pressure on the shelf and friction determine the rate of precession towards the mid-position as well as the small vertical motion.

Suppose the tilt to be corrected is R, when D presses H upward. The moment ma and its time of action (the total momental impulse) are too great, and R is over-corrected; this causes the rollers M' to act on L', and the spindles return to the mid-position; they go beyond the mid-position, and now the roller H' acts on D', and there is a return to the mid-position and beyond it, and so it goes on—the swings of the gyrostats out of and into the mid-position, and the vibrations of the car about its position of equilibrium getting rapidly less and less, until again neither H or H' nor M or M' is touching a shelf. It is indeed marvellous to see how rapidly the swings decay.²

It will be seen that by using the two gyrostats instead of one, when there is a curve on the line, although the plane NOO'N' rotates, and we may say that the gyrostats precess, the tilting couples which they exercise are equal and opposite.

It is evident that this method of Mr. Brennan is altogether different in character from that of Mr. Schlick.

¹ I am supposing the precessional angles to be small; when the angles are like NOQ, NO'Q', Fig. 3, the sum of the moments of the two gyrostats would be $ma \cos \theta$, θ being constant, if there were no slipping; but there is always slipping, and the good working of the apparatus requires that there shall be such slipping, α is not constant, and it is always less than what it would be if there was true rolling.

² If in Fig. 3 R is the angle which the wagon makes with its position of equilibrium; if M is the moment with which the shelf D acts clockwise upon H, and P is the angle of precession QO'N'; and if μ is the coefficient of friction between D and H, then in the first part of the action above described $16R - \mu \theta P - M = 0$, $m \theta R - 16P + \mu M = 0$, $(16\theta - \mu \theta)R + M = 0$, if $1, 1$, and $1/2$ are moments of inertia of the wagon about the rail, of the frames about C, and of the frame G about E; $1/2 m$ is the moment of momentum of either wheel. These equations are easily solved on the conditions that at $t = 0$, $R = R_0$, $\theta R = 0$, $P = 0$, $\theta P = 0$. Assuming no play, that is, that as soon as H leaves D, M' touches L, we can now find the return to the mid-position from a new set of equations. Friction retards the return, it must be remembered. The motions are exceedingly interesting when numerical values of $1, 1, 1/2$, &c., are taken, but the practical man will find it more interesting to make an experimental study of what happens.

Work is here actually done which must be supplied by the electromotors. The restoring moment applied to the car may be made as great as we please by increasing the diameter of H. It is true that we cannot in this way alter the total momental impulse, and this is the important thing.

One of the most important things to know is this: the Brennan model is wonderfully successful; the weight of the apparatus is not a large fraction of the weight of the wagon; will this also be the case with a real car which weighs 1000 times as much? If at any instant a condition of things is suddenly produced so that the wagon makes an angle R_0 with its position of equilibrium, if its weight is W , its centre of gravity at the height h above the rail, if I_1 is its moment of inertia about the rail as axis, if $1/2 m$ is the moment of momentum of each gyrostat wheel, the momental impulse mP , ought, roughly, to be equal to $CR_0 \sqrt{1/2 Wh}$, where C is a constant.

I use P , for the total angular precession at first. Now the tilt to be corrected, R_0 , may be due to wind pressure, to a sudden shifting of the centre of gravity, or to centrifugal force, and it is not easy to compare these things in wagons of different sizes. If, however, we take it that the size of each dimension of the wagon is multiplied by n and the size of each dimension of the gyrostatic apparatus is multiplied by p , and the wheels have the same peripheral speeds, we find the following results:— For wind, R_0 is proportional to n^{-1} . For centrifugal force it seems reasonable to take the speed of a wagon as proportional to n , and mean radius of rail curves proportional to n^2 . In this case the result is again that R_0 is proportional to n^{-1} . As for a possible accidental shifting of the centre of gravity because of the displacement of part of the cargo w through the distance d , if we take $w \propto n^2$ and $d \propto n$, we find with greater and greater accuracy as w is a smaller fraction of the whole weight, $R_0 \propto n^{-1}$.

Taking P , the maximum angle of precession, to be the same in all cases, the above relation leads to the result that $p = n^2$, or that the fractional weight of the apparatus as compared with that of the wagon is proportional to $W^{-0.125}$, where W is the weight of the wagon. Thus, if we take $n = 10$, that is, every dimension of the model multiplied by 10 or its weight by 1000, then $p = 7.5$, so that the weight of the gyrostat apparatus is only multiplied by 420. If in the model the apparatus was 10 per cent. of the whole weight, in the large wagon the apparatus is only 4 per cent. of the whole weight. In fact, the larger the wagon the less proportion of its weight and volume is occupied by the apparatus, a result which must be very satisfactory to Mr. Brennan.

In the cases both of Mr. Schlick and Mr. Brennan, it has to be remembered that if the diameter of the wheel be increased in greater proportion than the dimensions of the ship or wagon, or other dimensions of the wheel, the proportional weight of the apparatus may be diminished. A wheel of twice the diameter, but of the same weight, may have twice the moment of momentum and may be twice as effective. I assume the stresses in the material to be the same.

ON THE PHYSICAL ASPECT OF THE ATOMIC THEORY.¹

THE lecture began by setting out a physical reason *a priori* why matter should be constituted of discrete particles instead of being continuous. The requirements of physics demand an æther to serve as the means of communication between portions of matter out of contact with each other, and space can hardly be conceived as fully occupied simultaneously by two media, matter and æther; hence the matter must be constituted of discrete centres, or nuclei, determining permanent collocations of energy in the æther, which are, in fact, primordial atoms and their fields of force. The feasible problem of atomic physics is to build up an adequate idea of the dynamic constitution of these æthereal fields of force; there is the problem

¹ Abstract of the Wilde Lecture of the Manchester Literary and Philosophical Society, delivered on March 3 by Prof. J. Larmor, Sec.R.S.

beyond, to determine the intrinsic constitution of the central nuclei to which they are attached, which may remain permanently beyond our ken. The expansion of our ideas about the atoms, and their structural connection with the æther, was traced from their origin in Descartes, through Huygens and Newton, down to the more definite modern types of representation, as regards various essential features, that are afforded by the vortex atom and the electron.

In the hands of the physicists, especially Newton and Young, the atom had already become a complex structure, capable of definite, inherent, periods of free vibration, but, so far as physics was concerned, the same substance might include various kinds of atoms. The fundamental advance of Dalton, which assured an adequate domain to chemistry as an exact science, was the proof that each compound substance is definite as regards its molecule, and that all atoms of the same elementary body are identical. Whether this absolute identity points to the atom of each chemical element being a dynamically balanced structure of primordial atoms, one of a limited number of possible definite types of structure—which would be a perfectly reasonable way of accounting for this remarkable identity—remains an open question. The periodic relations of the elements, connected most closely with the name of Mendeléeff, certainly indicate that, whatever may be the case as regards the kernel, the outer structure of the atom, so to speak, which is the link through the æther between the nucleus and the outside world, is constituted on the basis of a common ultimate element which may be the electron.

The remark of Maxwell seems still to retain its force, that the mechanism of biological evolution could hardly reside in atoms, primordial or other, which had not much vaster underlying complication than is needed for their purely physical relations. The facts of biology may possibly demand a hypothesis such as the above, that atoms not in intimate contact interact through the æther according to general physical laws, in the manner required to constitute the physical cosmos, but that there may also be a closer interpenetration of atomic nuclei in which far more complex agencies are involved.

The mechanical atom of the earlier physicists, considered in this physical aspect, as an unknown core determining the field of activity in the surrounding æther, has had, since Faraday's discoveries in electrolysis, to take on a more definite form as the electrical atom. The result had been fully reached by Faraday himself, though it needed to be enforced later by Helmholtz, that the energies which have play in chemical combination are of electrical origin, implying thereby, according to Maxwell's interpretation, energies of intrinsic stress and motion brought to bear from atomic stores located in the adjacent æther. This doctrine has led on to the modern theory of purely electric atoms, which was already demonstrable on theoretical grounds, of course in a way less definite than we now know it, before the very remarkable discovery of electrons actually free had been reached, through the phenomena of radio-activity either electrically induced or spontaneous. Here again there is the same choice of points of view open to tentative development. We may proceed on a limited hypothesis as if the electrons are the sole primordial atoms; or we may assume that there are various ultimate atoms which have existence and structure of their own, of type largely unknown and independent of the æther, and that the electrons which are associated with them, whether temporarily or intrinsically, form merely one feature of their constitution, viz. their means of communication with the æther, and through it with other atoms at a distance to form an ordered universe.

In any case we are right in following out the hypothesis, there being, in fact, none other open to us, that the purely physical manifestations of atoms—those, namely, that, owing to the simple interconnection involved in their common seat in the æther, aggregate into the definite physical qualities of matter in bulk—are in the main or in most circumstances practically a group by themselves, and that they are thus capable of being investigated on these broad, simple principles of dynamics, which Newton definitely formulated as a suitable foundation for the analysis of general physical activity, as it presents itself

in the universe. This so-called mechanical hypothesis has been eminently the fruitful one; it pointed the way to the principle of the conservation of energy, and is now elucidating the wider principle of its definitely limited availability; it gave a rational explanation of the spectrum and of radiation in general, which has proved a trustworthy and precise guide to investigation of phenomena far below the surface, such as the selective dispersion of light and the magnetic action on radiation; it reduced electrical phenomena to order and control, and connected them with light. It must therefore be presumed to be available as the clue for the further elucidation of pressing problems, such as the nature of the transmission of gravitation and of the intimate operation of chemical affinities.

The tendency to reject dynamical analysis as artificial in such subjects as electrodynamics, which received some stimulus from the theoretical writings of Hertz, seems to overlook the fact that it was precisely as a compact working basis suitable for the formulation of experience in its more general aspects that the Newtonian scheme of dynamics was put forward by its author. In the course of time that scheme has become wider and more elastic through the generalisations of Lagrange and Hamilton, expanded forcibly on the physical side by Kelvin, Helmholtz, and various others. But to take over the final results, and dress them in new language devoid of the dynamical implication, seems to involve a misreading of scientific evolution.

This position may be enforced by a quotation from the final exposition of Newton's views on the scope of natural philosophy in general, inserted by himself at the end of the famous "Queries," in "Opticks," ed. 3, p. 377:—"To tell us that every Species of Things is endowed with an occult specific Quality by which it acts and produces manifest Effects, is to tell us nothing: But to derive two or three general Principles of Motion from Phenomena, and afterwards to tell us how the Properties and Actions of all corporeal Things follow from those manifest Principles, would be a very great step in Philosophy, though the Causes of those Principles were not yet discovered: And therefore I scruple not to propose the Principles of Motion above mention'd, they being of very general Extent, and leave their Causes to be found out." Then he proceeds to associate his laws of motion with an atomic theory.

A review of the electrical side of the atomic theory requires a consideration of the phenomena of ionisation in solutions. The theoretical difficulties which have presented themselves in this subject were discussed, in particular the nature of the energy changes which must occur when a salt is dissolved and thus split into separate ions. Reasoning from the processes of the voltaic cell, as expounded after Faraday by Helmholtz, the view is advanced that an equivalent of purely local potential energy of affinity with the solvent must be exhausted in order to provide for the separation of the ions, but without much violent motional disturbance such as would diffuse partially away into the form of heat. This absence of such motional dissipation of the energies of affinity, as indicated, for example, by their almost complete mechanical availability in a Daniell's cell, is perhaps connected with the intimate contacts in confined spaces which are characteristic of the processes at the electrodes by which the chemical change is effected. It is suggested that a similar mode of explanation applies to the very high, sometimes nearly complete, mechanical availability (Berthelot) of the energy of chemical transformations in dense media such as liquids and solids, as contrasted with dilute systems such as gases, which the recent work of Nernst and his pupils has brought again to the front.

The lecture passes on to touch on those extensive branches of chemical physics to which the constitution of the atom is not essential, where only a statistical grasp of the molecular associations and dissociations that are taking place is required. The quantitative theory of chemical equilibrium and of progress of chemical change as regards dilute systems comes under this head, of which the prototype and the most highly developed example is the kinetic theory of gases. The modern theory of electrodynamics, as based on the displacements and motions of electrons, is in the main analogous, and the theory of

gravitation, when it comes to light, will be of the same kind.

In particular, the molecular aspect of reaction in gases is passed under review. Reasons are brought forward for holding that in gases all ultimate reactions are of necessity mono- or bi-molecular. If this be so, the important work now proceeding with regard to the effect of impurities in promoting or inhibiting gaseous reactions must lead to fuller knowledge of the transient molecules or radicals which are formed in the destructive encounter of a pair of the reacting molecules, and are the carriers or intermediaries leading finally to poly-molecular change; while the same transient combinations may be approachable independently from another side as affording the interpretation of the complex banded spectra of emission or absorption in gaseous media.

The very remarkable and most fruitful and prophetic symbolic theories of molecular structure, especially for the complex molecules of organic chemistry, have not yet proved capable of dynamical interpretation; it seems necessary, however, to admit, on account of the wide range of physical properties that are nearly atomically additive, that stereochemical colloids do represent in some real way the actual aggregation of the atoms instead of mere symbolical representation of it. Recent investigation appears to bring out in certain cases a somewhat definite relation between the configuration of the molecule and the crystalline form of its physical aggregations, which, though reasonable, could not have been foreseen *a priori*; exact crystallographic measurements may thus in time afford another intimate clue to the molecular structures in related series of compounds.

A NEW METHOD OF STEREOSCOPIC PHOTOGRAPHY.

AN entirely novel suggestion for the production of stereoscopic photographs is proposed by Prof. G. Lippmann in the current number of the *Comptes rendus* of the Paris Academy of Sciences (March 2). Let a lens be constructed of a material possessing a refractive index n , the segments forming the front and back of the lens having the same centre of curvature and the ratio of the radius of curvature of the front segment to that at the back being $n-1$. The front surface is the receiving lens, and corresponds to the lens of the eye; the back surface is covered with the sensitive emulsion, and corresponds to the retina. Owing to the chosen relation between the curvatures of the two faces an image of a point is formed by the front surface on the back one. The system is reversible; a ray of light proceeding from any point of the receiving surface will pass out at the front over exactly the same path as that taken by the incoming light in acting on the sensitive film, and this will be true in spite of any imperfection of the lens surfaces.

Prof. Lippmann now imagines a material such as celluloid moulded back and front, so that the whole surface is covered with microscopic cells, each of which is an elementary cell possessing the properties of the single lens described above. The whole film resembles the compound eye of insects. This plate, sensitised, is exposed in full daylight to the objects to be represented, no photographic lens being required. The result of the operation would be a series of microscopic images fixed each on the "retina" of one of the cells. Seen from the side of the sensitive layer, the whole plate would present a uniformly grey appearance. But seen from the front and illuminated from behind the plate (supposed converted into a positive), the photograph would appear, and would possess the following peculiarities. It would appear in true relief, exactly as in nature, and shifting the eye about would produce a change in the photograph seen, the effect being as if the observer stood in front of a window. By stepping from side to side, in the latter case, fresh portions of the landscape would come into view, the whole always being bounded by the four sides of the window. In the case of such a plate as that described, the effect would be precisely similar.

As the author remarks in the paper, the technical difficulties in the preparation of such a plate would be very great. The chief difficulty would be the fulfilment of the con-

dition necessary for the clear definition of each image in each elementary cell; the ratio of the radii of curvature must be equal to $n-1$. Considering the thickness of the film, this difficulty would appear to be insuperable, but it is to be hoped that an attempt will be made to put this idea into practice, however imperfectly.

UNIVERSITY AND EDUCATIONAL INTELLIGENCE.

CAMBRIDGE.—During the last four years the average income of the botanic garden has been 1708*l.*, to which the University chest has contributed 117*l.*, the rest being made up of money from trust funds and from rents. The botanic garden syndicate now points out that the income is no longer sufficient to cover the expenses. The syndicate estimates that in future, if the gardens are to maintain their high position amongst kindred institutions, some additional income must be found, and it is recommended that the present grant from the University chest to the botanic garden be increased by the sum of 220*l.* per annum.

The next combined examination for sixty-seven entrance scholarships and a large number of exhibitions at Pembroke, Gonville and Caius, King's, Jesus, Christ's, St. John's, and Emmanuel Colleges will be held on Tuesday, December 1, and following days. Mathematics, classics, and natural sciences will be the subjects of examination at all these colleges. Some of the colleges allow candidates who intend to study mechanical sciences to compete for scholarships and exhibitions by taking the papers set in mathematics or natural science. The colleges desire it to be known that any candidate for a scholarship may signify in writing his wish not to receive the emolument of the same if elected thereto, and that such candidate may be elected to a scholarship which may be honorary only and without emolument, but shall carry with it all other privileges attached to the position of a scholar. The amount thus set free will serve to increase the number of scholarships or exhibitions open to other candidates.

GLASGOW.—Among the honorary degrees to be conferred by the University on April 22 are the following—*LL.D.*: Mr. G. T. Beilby, F.R.S., chairman of the governors of Glasgow and West of Scotland Technical College; Colonel David Bruce, C.B., F.R.S.; Dr. J. J. Dobbie, F.R.S., director of the Royal Scottish Museum, Edinburgh; Mr. R. Kidston, F.R.S.; and Dr. J. C. McVail, county medical officer, Stirlingshire and Dumbartonshire.

DR. R. STEWART MACDOUGALL, on his appointment to the lectureship in botany in Edinburgh University, has resigned his position as biologist on the staff of the Edinburgh and East of Scotland College of Agriculture.

MR. A. L. BOWLEY, reader in statistics in the University of London, will give a course of ten lectures on elementary applications of mathematics to statistical data at the School of Economics, at 7 p.m., on Thursdays, March 26 and April 2, resuming after the Easter vacation on May 7, and continuing thereafter for seven consecutive Thursdays.

THE Earl of Rosebery will visit University College on the afternoon of Thursday, March 26, and will formally open the new libraries and the new south wing, which includes lecture-rooms for the faculty of arts, the departments of geology, hygiene, and experimental psychology, also large extensions of the departments of applied mathematics, of mechanical, electrical, and municipal engineering, and accommodation for the new hydraulic laboratory.

THE first volume of the report of the U.S. Commissioner of Education for the year ending June 30, 1906, has been received from Washington. In addition to chapters summarising the progress made during the year under review in the various departments of American education, the report contains a series of excellent articles on educational administration in various European and other countries. A useful summary of the different sections of the report is provided in the commissioner's introduction.

and from this digest we notice there were, during 1905-6, 622 institutions of higher education reporting to the Washington Bureau of Education. The total number of professors and instructors in these institutions reached 23,950, and the number of students 258,603—an increase of 9430 on the preceding year. The value of the property possessed by the 622 institutions amounted to 110,815,400., of which 39,686,100. was the amount of productive funds. The aggregate income of these institutions for the year was 8,956,700. The total value of all gifts reported amounted to 3,543,300.; Harvard University received 443,600.; Yale University, 229,100.; Columbia University, New York, 210,000.; the University of Pennsylvania, 100,000.; and the North-Western University, Illinois, and Princeton University, New Jersey, each received about 105,000. In this report, for the first time, the number of students in schools of technology is not given separately, because, as the commissioner points out, there has been an erroneous opinion in Europe and elsewhere that there is no higher technical training in America outside the schools of technology, whereas the ordinary universities grant nearly twice as many degrees in science as the technical colleges, and are doing excellent work in pure and applied science generally.

We have received a couple of pamphlets (Leipzig: Verlag der Durr'schen Buchhandlung) which indicate the continued interest of the German public in both sides of the question of school reform. One of these pamphlets ("Die Stadt Berlin und das Reformgymnasium") is a reprint of a strenuous argument, which was originally delivered by Stadtschulrat Dr. Carl Michaelis in 1904, against tampering with the school system of the capital. Dr. Michaelis has brought the statistical portion of his address up to date, and finds in recent educational history nothing to weaken his former contention that the establishment of a Reformgymnasium in Berlin is demanded neither by the success of the reform movement generally nor by the specific educational conditions of the city. Further, while he makes it clear that he is far from opposed to well-considered changes in other directions, he defends the old gymnasium against the reformers as an indispensable part of the school system. In particular, he criticises the contention that the lower classes should be preparatory equally to all the recognised forms of secondary school, partly on the ground that the advantage which this arrangement is alleged to give the parent in selecting the school suitable to the abilities of his child is illusory, partly on the ground that no plan devised on these lines can accord with the necessary conception of a gymnasial education. Many of these arguments appear also in the second pamphlet ("Mathematik und Reformgymnasium"), in which Dr. H. Vogt endeavours to show that the teaching of mathematics suffers in respect both of the time given to the subject and of the value of the instruction where it is attempted to superimpose the gymnasial classes upon a foundation common to all the higher schools. The same firm of publishers has reprinted the address delivered in the University of Erlangen by Dr. Richard Falckenberg on the occasion of the centenary of the death of Kant (February 12, 1904).

The second annual report, dealing with the year 1907, of the president and treasurer of the Carnegie Foundation for the Advancement of Teaching has reached us. It will be remembered that Mr. Carnegie's gift of two million pounds sterling was intended to serve primarily in the establishment of retiring allowances for teachers in the institutions of higher learning in the United States, Canada, and Newfoundland, but that he left it to be administered for this purpose in such a manner as the trustees might decide to be wise. The fears expressed in some quarters that such a gift in the hands of a limited number of men might prove a centralised power which would hinder rather than aid the progress of education do not seem to have been well founded. Since the inauguration of the foundation down to September 30 last, grants have been made to 166 persons (eighteen of whom died during the period), involving an annual budget of 46,012. Of this amount, 20,200. was devoted to retiring allowances in accepted institutions, and 17,702. to retiring allowances made to individuals. In the group of retire-

ments on the basis of age an interesting comparison is made; the number of allowances granted on this basis to professors not in accepted institutions before October, 1900, was eighteen; since then only eight similar allowances have been made. This indicates that the number of aged professors whom on account of their distinguished merit alone the trustees would be likely to add to the holders of allowances is rapidly diminishing. It is also interesting to note that retiring allowances to professors in State universities are made only when the services rendered to learning by the applicant have been of great distinction. As indicative of the number of applications made to the trustees, it may be stated that the files of the foundation show that 500 applications have been refused. It is satisfactory to learn that when once the principles of award have been decided upon finally, the trustees will see that the retiring allowance comes to the recipient "as a right, not as a charity; as a thing earned in the regular course of service, not a courtesy."

SOCIETIES AND ACADEMIES.

LONDON.

Physical Society, February 14.—Prof. J. Perry, F.R.S., president, in the chair.—Annual general meeting. Address by the newly elected president, Dr. C. Chree. Dr. Chree referred to the magnetic results obtained by the National Antarctic Expedition of 1901-4. The expedition was furnished with magnetographs, and the reduction and discussion of the curves has been done by the National Physical Laboratory. Before describing the results, the president spoke of the nature of the preparations that might be made in any future national scientific expedition. The observers should have a preliminary training lasting over some months, and should be practised in the use of instruments. These instruments ought to be ready for use and fully tested months before the date of the expedition. A programme should be got out in good time, so as to admit of rehearsals by the observers. An inquiry, after the return of the expedition, into the value of the results obtained might be useful in securing that meritorious work in science would not be overlooked. Lantern-slides relating to the diurnal inequalities of the magnetic elements in the Antarctic were exhibited and described. Slides of corresponding Kew results were shown for intercomparison. The president dwelt on the relatively highly disturbed nature of the Antarctic records. In the Antarctic, the declination and horizontal force magnets were practically never at rest. So large and incessant were the disturbances that no idea of the nature of the regular diurnal inequality was obtainable from inspection of individual curves. Diurnal inequalities, however, derived from the curves of single months, and still more of a whole season of the year, proved to be of a comparatively smooth character.

Royal Meteorological Society, February 19.—Dr. H. R. Mill, president, in the chair.—The formation of "snow rollers" observed at Ryton on Dunsmore, near Coventry, on January 20-30, 1907: C. Browett. It seems that the flakes of a light fluffy layer of surface snow are made adhesive by a rise in the temperature of the air above the freezing point, while the under snow remains cold and dry, and the particles of damp surface snow are enabled to adhere to each other, but not to the dry under snow. A strong wind may then push over little projections of the surface snow and start them rolling, when, of course, they will travel and grow until the resistances overcome the propelling power of the wind. These "snow rollers" vary in size, some being only a few inches in diameter, while at times others have been seen 2 feet or more in length.—Comparison of ships' barometer readings with those deduced from land observations: E. Gold. This paper contained the result of a preliminary investigation undertaken at the Meteorological Office into the relation between the barometer readings taken on ships during their passage across a line between Falmouth and Brest, and the readings deduced for the ships' positions from the observations at these places and the trend of the isobars, on the assumption of regular pressure changes. Taking into account the various causes which can appreciably

influence the height of the barometer on board ship, it appears that until the two chief ones—the wind and the vertical acceleration effects—are eliminated, it will be impossible to draw any satisfactory conclusions regarding the relative values of atmospheric pressure over sea and land. It can be said in general that there appears to be a tendency for the barometric pressure to be lower between Falmouth and Brest than would be expected from the land observations.

Geological Society, February 19.—Sir Archibald Geikie, K.C.B., Sec.R.S., president, in the chair.—The two earth-movements of Colonsay: W. B. Wright. The supposed Torridonian rocks of Colonsay exhibit in their folding and cleavage the effects of two movements analogous in their results to those proved by Mr. Clough in the Cowal district of Argyll. Not only the planes of the first or slaty cleavage, but also the quartz veins formed along them, have been folded by the second movement, and may be observed to be crossed at considerable angles by the cleavage produced during this second movement. An extensive series of lamprophyre dykes, obviously later than the first cleavage, are found to be folded and cleaved by the second movement. Moreover, some of these dykes traverse and are chilled against a mass of syenite, which can also be proved to be later than the first cleavage. The distinctness of these two movements is, therefore, considered to be completely established. The second cleavage being of the nature of strain-slip, its development along the axial planes of the folds is of interest, and is briefly discussed.—Notes on the River Wey: H. Bury. The part of the River Wey within the Wealden area is divided into six sections:—(1) the consequent river cutting the Chalk at Guildford; (2) the subsequent stream coming in from the east at Shalford; (3) the western subsequent stream parallel to the Hog's Back; (4) the continuation of the last westward (the Tilford River), rising at Selborne and receiving many tributaries, including the Headley River, from between Blackdown and Hindhead; (5) the short obsequent section from Farnham to Tilford (the Waverley River); and (6) the portion above Farnham coming from Alton and beyond (the Farnham River). Part i. deals with the relation of sections (6), (5), and (4) to the Blackwater; part ii. with the Palaeolithic Gravels of Farnham; and part iii. with the Farnham branch of the Wey and the Alton district, which is remarkable in that there is a complicated series of Chalk valleys, which spread over some fifty square miles of country and discharge their waters into the Wealden area.

Royal Microscopical Society, February 19.—Mr. A. N. Disney in the chair.—An improved type of mercury vapour lamp for use with the microscope: J. E. Barnard.—Eye-pieces for the microscope: Mr. Nelson.—Results of observations, extending over a period of four years, on a rare protophyte: Rev. E. Tozer.—Dimorphism in the recent foraminifer *Alveolina bosci*: F. Chapman.—*Biddulphia mobilensis*: Mr. Nelson. The author described some exceedingly minute secondary markings in the primary areolations of this diatom, discovered by him.

Faraday Society, February 25.—Dr. T. M. Lowry in the chair.—Hydrolysis as illustrated by heats of neutralisation: V. H. Voley. It is pointed out that a correlation of hydrolysis values and basic constants deduced therefrom with those of heats of neutralisation presents important issues. Determinations by an accurate method at different temperatures are required to test the validity of Nernst equation $Q = RT \epsilon^{\frac{d \log^{10} K}{dt}}$. Relationships of a general character are discussed for the hydrochlorides of nitrogen bases, also of certain sodium salts of phenols and organic acids. The effect on thermoneutrality and basic constants by the introduction of a second amino-grouping is considered. Finally, it is pointed out that determinations are required of hydrolysis values at considerable dilution of certain metallic chlorides.—A study of the sulphur anion and of complex sulphur anions: Joseph Knox. The solubility of HgS, red and black, in Na₂S, K₂S, and BaS solutions has been determined, and has been found to depend on the formation of the complex anion

HgS⁴. By its greater solubility in these solutions the black modification of HgS has been shown to be the less stable form. The constant for the formation of the complex anion from the ions Hg²⁺ and S⁴⁻ is

$$K = \frac{[H_4S_2^{4-}]}{[Hg^{2+}][S^{4-}]^2} = 5.1 \times 10^4.$$

From saturated solutions of Na₂S and HgS a crystalline double sulphide of sodium and mercury, 2Na₂S.HgS.3H₂O, has been isolated. From the study of the complex formation between HgS and Na₂S it is concluded that Na₂S is almost completely hydrolysed into NaOH and NaSH.

Royal Anthropological Institute, February 25.—Mr. A. L. Lewis in the chair.—Montenegrin manners and customs: M. Edith Durham. An account was given of the people's beliefs in spirits and fabulous serpents, with their marriage arrangements and funeral ceremonies. All cousins, to whatever degree, are considered as blood relations, and marriage between them is prohibited, and it is interesting to note that godfatherhood is also a recognised relationship, a godson becoming of blood kin to all his godfather's relations.

CAMBRIDGE.

Philosophical Society, January 27.—Dr. Hobson, president, in the chair.—(1) Exhibition and description of a portion of a fossil jaw of one of the Equidae (British East Africa); (2) exhibition of zebra skins (thirteen) and skulls (four) from British East Africa, with special reference to the problem of the centre of distribution of the three species of zebras: Prof. Ridgeway.—A new genus of Ixodoidea, together with a description of eleven new species of ticks: Prof. Nuttall and C. Warburton.—(1) Report on the brain of a microcephalous idiot; (2) description of a microcephalous new-born pig: Dr. Duckworth.

February 10.—Mr. S. Ruhemann, vice-president, in the chair.—The nature of γ rays: Prof. J. J. Thomson. The author supported the view that the γ rays have a structure similar to that ascribed to the Röntgen rays in his "Discharge of Electricity through Gases," consisting of small pulses of electric force, the pulses having a very small area as well as being very thin. These pulses form a system made up of separate units, which may be at considerable distances from each other. Each of the units possesses mass, momentum, and energy. It was shown that all the properties of the γ rays could be explained on this view without the introduction of the somewhat far-fetched hypotheses which are necessary if the view that the γ rays are combinations of positive and negative ions is adopted.—The velocity of cathodic secondary radiation: Prof. J. J. Thomson. A method of measuring the velocity of secondary kathode rays from gases was described, and by the use of this method it was shown that the maximum velocity of the secondary rays is independent of that of the primary rays. Cases were described in which the velocity of the secondary rays was greater than that of the primary rays from which they originated, showing that the secondary rays result from a kind of explosion of the atoms of the gas through which the primary rays pass.—The spectrum of the discharge from a glowing lime cathode in mercury vapour: F. Horton. The discharge tube used had a cathode consisting of a strip of platinum foil covered with lime or a mixture of lime and baryta. This could be heated by means of an electric current. The anode was either aluminium, platinum, or mercury. The spectrum showed the lines of the residual gas and those of mercury. On pumping out the residual gas its spectrum gradually disappeared and the mercury spectrum increased in brilliancy, and, at the same time, three new lines appeared in the orange and two new lines in the red. These lines were quite sharp and bright, and are not given in the ordinary tables of mercury lines. Experiments showed that these lines were not due to calcium or barium, but were connected with the presence of mercury vapour in the discharge tube. It seems probable, therefore, that the method of producing the ionisation used in these experiments gives rise to spectral lines which do not occur in the ordinary vacuum tube, arc, or spark spectra of mercury.—An example of complex double integration: Dr. A. C. Dixon.

DUBLIN.

Royal Dublin Society, February 18.—Prof. Sydney Young, F.R.S., in the chair.—*Spongospora Solani*, Brunch.: Prof. T. Johnson. The author gave an account of a scab which he found last summer doing much harm to the potato crop along the west coast of Ireland. The scab is caused by *Spongospora Solani*, Brunch., a slime-fungus allied to *Plasmodiophora*. The author describes the germination of the spores, as well as the resting plasmodium, and concludes that *Spongospora* agrees in its mode of reproduction with *Ceratiomyxa*, as described by Jahn, not with the other Myxomycetes. The author had the opportunity, through the kindness of Colonel Prain, F.R.S., the director of the Royal Gardens, Kew, of examining the spore-balls of *Sorosporium scabies* (Berk.), Fisch. d. Wald., which agree with those of *Spongospora Solani*. He expresses the opinion that *S. scabies* may prove to be, not a member of *Ustilaginaceae*, but identical with *Spongospora Solani*, a slime-fungus.—The radium content of deep-sea sediments: Prof. J. Joly. The paper is a record of experiments on material kindly supplied by Sir John Murray, F.R.S. The quantity of radium is found to increase with distance from land, the central Pacific oozes (Radiolarian ooze and Red Clay) rising above 50×10^{-12} grams radium per gram. Manganese nodules, Globigerina ooze, and Blue Mud were also examined. The Blue Mud is poorer in radium than many terrestrial sediments.

PARIS.

Academy of Sciences, March 2.—M. H. Becquerel in the chair.—Some phosphorescence spectra: Henri Becquerel. A comparison of the phosphorescent and flame spectra of various specimens of fluor-spar, apatite, and scheelite from different localities. The bands cannot be wholly attributed to the traces of rare earths present in these minerals.—Reversible photographs: G. Lippmann (see p. 452).—Machines for driving away hail: J. Violle. So far as can be settled by direct experiments, a single detonation is practically without effect on a storm cloud. The effects of volleys from a large number of hail cannons seem to be capricious; a violent storm is practically unaffected by them, but a slowly moving cloud approaching the district by a known path may be diverted successfully.—Lithium in active minerals: Sir William Ramsay and Alex. Cameron. Referring to the results of Prof. McCoy and of Alle. Gleditsch on the presence of lithium in certain radioactive minerals, it is pointed out that lithium is not regarded as the sole product of change when copper salts are treated with the radium emanation; other members of the alkali group may also be produced (see NATURE, March 5, p. 412).—The direct hydrogenation of the aromatic quinones: Paul Sabatier and A. Mailhe. With reduced nickel at 100°C ., quinone is converted nearly quantitatively into hydroquinone. At higher temperatures products of decomposition, phenol and benzene, are found. The reaction also applies to toluquinone, paxylquinone, and thymoquinone.—Surfaces with coincident lines of curvature: L. Raffy. The case of reduction of the differential equations of the trajectory of an electrified corpuscle in a magnetic field: Carl Störmer.—Electrical measurement of small lengths: A. Guillet.—The voltaic arc working in an enclosed space limited by a thick wall: Adolphe Minet.—The heat of vaporisation of propionic acid: A. Faucon. This constant, measured with the Berthelot apparatus, was found to be 90.4. This gives a Trouton constant of 16.2, lower than the normal figure of 20 to 21. Formic and acetic acids show the same abnormality.—The determination of the atomic weight of cerium: G. Jantsch. The purity of the europium preparation and its freedom from samarium and gadolinium was proved by superimposing the arc spectra of all three on the same plate. The only lines common to the three were the parasitic lines from the arc, belonging to iron, silicon, and magnesium in the carbon electrodes. The ratio $\text{Eu}(\text{SO}_4)_2 \cdot 8\text{H}_2\text{O} : \text{Eu}_2\text{O}_3$ was determined experimentally, and gave an atomic weight of 152 ($\text{O} = 16$). This is in close agreement with the number previously found by MM. Urbain and Lacombe.—The oxidation of platinum: C. Marie. Evidence has been obtained that a minute amount of an oxide of platinum can be produced by the action of various oxidising agents

at the ordinary temperature.—A new type of combination of sulphur with certain iodides: V. Auger. The preparation of the following compounds is described: $\text{—CHI}_{3.5}\text{S}_8$, $\text{C}_2\text{I}_4\text{S}_8$, $\text{AsI}_3 \cdot 3\text{S}_8$, $\text{SbI}_3 \cdot 3\text{S}_8$. All these are well crystallised, and have been analysed.—Syntheses by means of the mixed organometallic derivatives of zinc. Ketone alcohols: E. E. Blaise and I. Herman. The ketone alcohol $\text{C}_6\text{H}_5 \cdot \text{CO} \cdot \text{C}(\text{CH}_3)_2 \cdot \text{OH}$ has been obtained by the action of $\text{C}_6\text{H}_5 \cdot \text{Zn} \cdot \text{I}$ upon $\text{CH}_3 \cdot \text{CO} \cdot \text{O} \cdot \text{C}(\text{CH}_3)_2 \cdot \text{COCl}$, and subsequent saponification with cold dilute caustic soda solution.—The preparation and characters of crystallised *d*-talite: Gabriel Bertrano and P. BrunEAU. A detailed description is given of the improvements in E. Fischer's method of preparing *d*-talite, by means of which, starting with galactonic acid, 75 per cent. of the re-crystallised substance is obtained instead of 1 per cent. of the carbohydrate in the form of syrup. The physical and chemical properties of the crystallised product are given.—Physico-chemical researches on soaps considered as colloids: André Mayer, Georges Schaeffer, and E. F. Terrone.—The sorting of minerals by the electromagnet: A. Chevallier and L. VÉRAIN.—The application to thorium of a general method of synthesis of fluorides and silicates: A. Duboin.—The existence of cephalic glands in *Machilis maritima*: L. Bruntz.—A Lepidoptera (*Zeuca pyrina*) causing damage to the cork tree in Algeria: P. Lesne.—Spectroscopic examination of the bile: A. AUCHÉ.—The method is based on the production of a characteristic absorption spectrum by bilirubin when oxidised under certain conditions which are defined.—Some new work on kala-azar cultures: inoculation of the dog; etiology: Charles NICOLLE.—The rocks and Permian strata at Châtillon-sur-Saône (Vosges): A. Doby.—The existence of a Permian fauna and flora at Madagascar: Marcellin Boule.—The infra-Lias of Hodna (Algeria): J. Savornin.

CALCUTTA.

Asiatic Society of Bengal, February 5.—Hindustani-English glossary of birds, chiefly from Jerdon: Lieutenant Colonel D. C. Phillott and Pandit Gobin Lal Bonnerjee.—Notes on the pollination of flowers in India. Note No. 5. Some autumn observations in the Sikkim Himalaya: I. H. Burkill. The observations were made above 7000 feet in the autumns of 1904 and 1906, on two journeys from Darjeeling along the Singla ridge. The climate of the ridge is a very moist one, and an unusual percentage of flowers are pendent, possibly profiting thereby because their honey escapes dilution and their pollen injury from the rain. Bombi visit many of the flowers, even working in the rain, and are found at all elevations; a long-tongued Bombyliid fly of the genus *Lycastris* is frequent above 8000 feet to 9000 feet. The trees of the ridge are almost all spring-flowering, and the flowering plants of the autumn flora are almost all herbs.—Notes on the pollination of flowers in India. Note No. 6. The spring flora in the Simla Hills: I. H. Burkill. Observations made in the end of April and beginning of May, 1906 and 1907, are recorded. The flora and fauna are very European in character, but the flora is of a much more specialised type than is the spring flora of, for instance, the Grampians of Scotland. The weather in May is generally dry, and pendulous flowers are not very numerous.—Fat of the Himalayan bear: D. Hooper. Analysis of the fat of *Ursus torquatus* as used medicinally in the Himalaya.—Monograph of sea-snakes: Captain F. Wall. A full and illustrated account of the sea-snakes of the world based on study in several museums.—A note on the calm region in the atmosphere, which in the neighbourhood of Calcutta, during the cold season, is at a height of 3000 feet to 4000 feet: C. Little. The object of the note is to make known the existence of the calm region at almost a uniform height throughout any one cold season, as well as from year to year. The information has been collected by observing paper balloons of different sizes, some filled with coal gas and some with hydrogen, and brief details are given of the method of observation. The altitude and azimuth of the balloon were noted at intervals of two minutes, and at the same time the diameter of the image of the balloon in a 3-inch telescope of 42 inches focal length was measured by a micrometer. Assuming this last measurement to be x thousandths of an inch, the

distance would be 126,000/x feet, the balloon being 3 feet in diameter. From these measurements the position of the object in space is determined, and consequently the air movements at the different levels to which the object rises, assuming the air movement to be horizontal. With a 3-foot balloon filled with hydrogen gas, or with one of a 5-foot diameter filled with coal gas, the greatest elevation attained varies from 7000 feet to 10,000 feet. It has been found in all cases that up to 4000 feet the air movement is quite different from what it is above that level, and that in passing from the lower to the upper layer of air the balloon passes through one that has very little motion.

DIARY OF SOCIETIES.

THURSDAY, MARCH 12.

ROYAL SOCIETY, at 4.30.—Description of the Brain of Mr. Charles Babbage, F.R.S.; Sir Victor Horsley, F.R.S.—The Origin and Destiny of Cholesterol in the Animal Organism. Part II, The Excitation of Cholesterol by the Dog; C. Dorez and J. A. Gardner.—On Reciprocal Inervation in Vasomotor Reflexes and the Action of Strychnine and of Chloroform thereon; Dr. W. M. Bayliss, F.R.S.—Bacteria as Agents in the Oxidation of Amorphous Carbon; Prof. M. C. Potter.—The Life-history of *Trypansoma equiperdum*; Prof. J. E. Salvin-Moore and Anton Ireni.

ROYAL INSTITUTION, at 3.—Early British History and Epigraphy; Sir John Rhys.

ROYAL SOCIETY OF ARTS, at 4.30.—Progress in the Native States of India during the past Forty Years; Sir David W. K. Barr, K.C.S.I.

MATHEMATICAL SOCIETY, at 5.30.—On the Projective Geometry of some Covariants of a Cubic; Prof. E. B. Elliott.—On the Inequalities connecting the Double and Repeated Upper and Lower Integrals of a Function of Two Variables; Dr. W. H. Young.—On the Operational Expression of Taylor's Theorem; W. F. Sheppard.—On a Formula for the Sum of a Finite Number of Terms of the Hypergeometric Series when the Fourth Element is Unity (Second Paper); Prof. M. J. M. Hill.—Note on a Soluble Dynamical Problem; Prof. L. J. Rogers.

INSTITUTION OF ELECTRICAL ENGINEERS, at 8.—America Re-visited, 1907; Sir W. H. Preece, K.C.B., F.R.S.

FRIDAY, MARCH 13.

ROYAL ASTRONOMICAL SOCIETY, at 8.—Observations of the Transit of Mercury, 1507 November 14; T. F. Claxton.—Photometric Measurements of Saturn, 1907 August–December; J. M. Baldwin.—Reappearance of Saturn's Ring, 1908 January; R. T. A. Jones.—On the Orbits of 433, 2243, 2245, 2246, 2247, 2248, 2249, 2250, 2251, 2252, 2253, 2254, 2255, 2256, 2257, 2258, 2259, 2260, 2261, 2262, 2263, 2264, 2265, 2266, 2267, 2268, 2269, 2270, 2271, 2272, 2273, 2274, 2275, 2276, 2277, 2278, 2279, 2280, 2281, 2282, 2283, 2284, 2285, 2286, 2287, 2288, 2289, 2290, 2291, 2292, 2293, 2294, 2295, 2296, 2297, 2298, 2299, 2300, 2301, 2302, 2303, 2304, 2305, 2306, 2307, 2308, 2309, 2310, 2311, 2312, 2313, 2314, 2315, 2316, 2317, 2318, 2319, 2320, 2321, 2322, 2323, 2324, 2325, 2326, 2327, 2328, 2329, 2330, 2331, 2332, 2333, 2334, 2335, 2336, 2337, 2338, 2339, 2340, 2341, 2342, 2343, 2344, 2345, 2346, 2347, 2348, 2349, 2350, 2351, 2352, 2353, 2354, 2355, 2356, 2357, 2358, 2359, 2360, 2361, 2362, 2363, 2364, 2365, 2366, 2367, 2368, 2369, 2370, 2371, 2372, 2373, 2374, 2375, 2376, 2377, 2378, 2379, 2380, 2381, 2382, 2383, 2384, 2385, 2386, 2387, 2388, 2389, 2390, 2391, 2392, 2393, 2394, 2395, 2396, 2397, 2398, 2399, 2400, 2401, 2402, 2403, 2404, 2405, 2406, 2407, 2408, 2409, 2410, 2411, 2412, 2413, 2414, 2415, 2416, 2417, 2418, 2419, 2420, 2421, 2422, 2423, 2424, 2425, 2426, 2427, 2428, 2429, 2430, 2431, 2432, 2433, 2434, 2435, 2436, 2437, 2438, 2439, 2440, 2441, 2442, 2443, 2444, 2445, 2446, 2447, 2448, 2449, 2450, 2451, 2452, 2453, 2454, 2455, 2456, 2457, 2458, 2459, 2460, 2461, 2462, 2463, 2464, 2465, 2466, 2467, 2468, 2469, 2470, 2471, 2472, 2473, 2474, 2475, 2476, 2477, 2478, 2479, 2480, 2481, 2482, 2483, 2484, 2485, 2486, 2487, 2488, 2489, 2490, 2491, 2492, 2493, 2494, 2495, 2496, 2497, 2498, 2499, 2500, 2501, 2502, 2503, 2504, 2505, 2506, 2507, 2508, 2509, 2510, 2511, 2512, 2513, 2514, 2515, 2516, 2517, 2518, 2519, 2520, 2521, 2522, 2523, 2524, 2525, 2526, 2527, 2528, 2529, 2530, 2531, 2532, 2533, 2534, 2535, 2536, 2537, 2538, 2539, 2540, 2541, 2542, 2543, 2544, 2545, 2546, 2547, 2548, 2549, 2550, 2551, 2552, 2553, 2554, 2555, 2556, 2557, 2558, 2559, 2560, 2561, 2562, 2563, 2564, 2565, 2566, 2567, 2568, 2569, 2570, 2571, 2572, 2573, 2574, 2575, 2576, 2577, 2578, 2579, 2580, 2581, 2582, 2583, 2584, 2585, 2586, 2587, 2588, 2589, 2590, 2591, 2592, 2593, 2594, 2595, 2596, 2597, 2598, 2599, 2600, 2601, 2602, 2603, 2604, 2605, 2606, 2607, 2608, 2609, 2610, 2611, 2612, 2613, 2614, 2615, 2616, 2617, 2618, 2619, 2620, 2621, 2622, 2623, 2624, 2625, 2626, 2627, 2628, 2629, 2630, 2631, 2632, 2633, 2634, 2635, 2636, 2637, 2638, 2639, 2640, 2641, 2642, 2643, 2644, 2645, 2646, 2647, 2648, 2649, 2650, 2651, 2652, 2653, 2654, 2655, 2656, 2657, 2658, 2659, 2660, 2661, 2662, 2663, 2664, 2665, 2666, 2667, 2668, 2669, 2670, 2671, 2672, 2673, 2674, 2675, 2676, 2677, 2678, 2679, 2680, 2681, 2682, 2683, 2684, 2685, 2686, 2687, 2688, 2689, 2690, 2691, 2692, 2693, 2694, 2695, 2696, 2697, 2698, 2699, 2700, 2701, 2702, 2703, 2704, 2705, 2706, 2707, 2708, 2709, 2710, 2711, 2712, 2713, 2714, 2715, 2716, 2717, 2718, 2719, 2720, 2721, 2722, 2723, 2724, 2725, 2726, 2727, 2728, 2729, 2730, 2731, 2732, 2733, 2734, 2735, 2736, 2737, 2738, 2739, 2740, 2741, 2742, 2743, 2744, 2745, 2746, 2747, 2748, 2749, 2750, 2751, 2752, 2753, 2754, 2755, 2756, 2757, 2758, 2759, 2760, 2761, 2762, 2763, 2764, 2765, 2766, 2767, 2768, 2769, 2770, 2771, 2772, 2773, 2774, 2775, 2776, 2777, 2778, 2779, 2780, 2781, 2782, 2783, 2784, 2785, 2786, 2787, 2788, 2789, 2790, 2791, 2792, 2793, 2794, 2795, 2796, 2797, 2798, 2799, 2800, 2801, 2802, 2803, 2804, 2805, 2806, 2807, 2808, 2809, 2810, 2811, 2812, 2813, 2814, 2815, 2816, 2817, 2818, 2819, 2820, 2821, 2822, 2823, 2824, 2825, 2826, 2827, 2828, 2829, 2830, 2831, 2832, 2833, 2834, 2835, 2836, 2837, 2838, 2839, 2840, 2841, 2842, 2843, 2844, 2845, 2846, 2847, 2848, 2849, 2850, 2851, 2852, 2853, 2854, 2855, 2856, 2857, 2858, 2859, 2860, 2861, 2862, 2863, 2864, 2865, 2866, 2867, 2868, 2869, 2870, 2871, 2872, 2873, 2874, 2875, 2876, 2877, 2878, 2879, 2880, 2881, 2882, 2883, 2884, 2885, 2886, 2887, 2888, 2889, 2890, 2891, 2892, 2893, 2894, 2895, 2896, 2897, 2898, 2899, 2900, 2901, 2902, 2903, 2904, 2905, 2906, 2907, 2908, 2909, 2910, 2911, 2912, 2913, 2914, 2915, 2916, 2917, 2918, 2919, 2920, 2921, 2922, 2923, 2924, 2925, 2926, 2927, 2928, 2929, 2930, 2931, 2932, 2933, 2934, 2935, 2936, 2937, 2938, 2939, 2940, 2941, 2942, 2943, 2944, 2945, 2946, 2947, 2948, 2949, 2950, 2951, 2952, 2953, 2954, 2955, 2956, 2957, 2958, 2959, 2960, 2961, 2962, 2963, 2964, 2965, 2966, 2967, 2968, 2969, 2970, 2971, 2972, 2973, 2974, 2975, 2976, 2977, 2978, 2979, 2980, 2981, 2982, 2983, 2984, 2985, 2986, 2987, 2988, 2989, 2990, 2991, 2992, 2993, 2994, 2995, 2996, 2997, 2998, 2999, 3000, 3001, 3002, 3003, 3004, 3005, 3006, 3007, 3008, 3009, 3010, 3011, 3012, 3013, 3014, 3015, 3016, 3017, 3018, 3019, 3020, 3021, 3022, 3023, 3024, 3025, 3026, 3027, 3028, 3029, 3030, 3031, 3032, 3033, 3034, 3035, 3036, 3037, 3038, 3039, 3040, 3041, 3042, 3043, 3044, 3045, 3046, 3047, 3048, 3049, 3050, 3051, 3052, 3053, 3054, 3055, 3056, 3057, 3058, 3059, 3060, 3061, 3062, 3063, 3064, 3065, 3066, 3067, 3068, 3069, 3070, 3071, 3072, 3073, 3074, 3075, 3076, 3077, 3078, 3079, 3080, 3081, 3082, 3083, 3084, 3085, 3086, 3087, 3088, 3089, 3090, 3091, 3092, 3093, 3094, 3095, 3096, 3097, 3098, 3099, 3100, 3101, 3102, 3103, 3104, 3105, 3106, 3107, 3108, 3109, 3110, 3111, 3112, 3113, 3114, 3115, 3116, 3117, 3118, 3119, 3120, 3121, 3122, 3123, 3124, 3125, 3126, 3127, 3128, 3129, 3130, 3131, 3132, 3133, 3134, 3135, 3136, 3137, 3138, 3139, 3140, 3141, 3142, 3143, 3144, 3145, 3146, 3147, 3148, 3149, 3150, 3151, 3152, 3153, 3154, 3155, 3156, 3157, 3158, 3159, 3160, 3161, 3162, 3163, 3164, 3165, 3166, 3167, 3168, 3169, 3170, 3171, 3172, 3173, 3174, 3175, 3176, 3177, 3178, 3179, 3180, 3181, 3182, 3183, 3184, 3185, 3186, 3187, 3188, 3189, 3190, 3191, 3192, 3193, 3194, 3195, 3196, 3197, 3198, 3199, 3200, 3201, 3202, 3203, 3204, 3205, 3206, 3207, 3208, 3209, 3210, 3211, 3212, 3213, 3214, 3215, 3216, 3217, 3218, 3219, 3220, 3221, 3222, 3223, 3224, 3225, 3226, 3227, 3228, 3229, 3230, 3231, 3232, 3233, 3234, 3235, 3236, 3237, 3238, 3239, 3240, 3241, 3242, 3243, 3244, 3245, 3246, 3247, 3248, 3249, 3250, 3251, 3252, 3253, 3254, 3255, 3256, 3257, 3258, 3259, 3260, 3261, 3262, 3263, 3264, 3265, 3266, 3267, 3268, 3269, 3270, 3271, 3272, 3273, 3274, 3275, 3276, 3277, 3278, 3279, 3280, 3281, 3282, 3283, 3284, 3285, 3286, 3287, 3288, 3289, 3290, 3291, 3292, 3293, 3294, 3295, 3296, 3297, 3298, 3299, 3300, 3301, 3302, 3303, 3304, 3305, 3306, 3307, 3308, 3309, 3310, 3311, 3312, 3313, 3314, 3315, 3316, 3317, 3318, 3319, 3320, 3321, 3322, 3323, 3324, 3325, 3326, 3327, 3328, 3329, 3330, 3331, 3332, 3333, 3334, 3335, 3336, 3337, 3338, 3339, 3340, 3341, 3342, 3343, 3344, 3345, 3346, 3347, 3348, 3349, 3350, 3351, 3352, 3353, 3354, 3355, 3356, 3357, 3358, 3359, 3360, 3361, 3362, 3363, 3364, 3365, 3366, 3367, 3368, 3369, 3370, 3371, 3372, 3373, 3374, 3375, 3376, 3377, 3378, 3379, 3380, 3381, 3382, 3383, 3384, 3385, 3386, 3387, 3388, 3389, 3390, 3391, 3392, 3393, 3394, 3395, 3396, 3397, 3398, 3399, 3400, 3401, 3402, 3403, 3404, 3405, 3406, 3407, 3408, 3409, 3410, 3411, 3412, 3413, 3414, 3415, 3416, 3417, 3418, 3419, 3420, 3421, 3422, 3423, 3424, 3425, 3426, 3427, 3428, 3429, 3430, 3431, 3432, 3433, 3434, 3435, 3436, 3437, 3438, 3439, 3440, 3441, 3442, 3443, 3444, 3445, 3446, 3447, 3448, 3449, 3450, 3451, 3452, 3453, 3454, 3455, 3456, 3457, 3458, 3459, 3460, 3461, 3462, 3463, 3464, 3465, 3466, 3467, 3468, 3469, 3470, 3471, 3472, 3473, 3474, 3475, 3476, 3477, 3478, 3479, 3480, 3481, 3482, 3483, 3484, 3485, 3486, 3487, 3488, 3489, 3490, 3491, 3492, 3493, 3494, 3495, 3496, 3497, 3498, 3499, 3500, 3501, 3502, 3503, 3504, 3505, 3506, 3507, 3508, 3509, 3510, 3511, 3512, 3513, 3514, 3515, 3516, 3517, 3518, 3519, 3520, 3521, 3522, 3523, 3524, 3525, 3526, 3527, 3528, 3529, 3530, 3531, 3532, 3533, 3534, 3535, 3536, 3537, 3538, 3539, 3540, 3541, 3542, 3543, 3544, 3545, 3546, 3547, 3548, 3549, 3550, 3551, 3552, 3553, 3554, 3555, 3556, 3557, 3558, 3559, 3560, 3561, 3562, 3563, 3564, 3565, 3566, 3567, 3568, 3569, 3570, 3571, 3572, 3573, 3574, 3575, 3576, 3577, 3578, 3579, 3580, 3581, 3582, 3583, 3584, 3585, 3586, 3587, 3588, 3589, 3590, 3591, 3592, 3593, 3594, 3595, 3596, 3597, 3598, 3599, 3600, 3601, 3602, 3603, 3604, 3605, 3606, 3607, 3608, 3609, 3610, 3611, 3612, 3613, 3614, 3615, 3616, 3617, 3618, 3619, 3620, 3621, 3622, 3623, 3624, 3625, 3626, 3627, 3628, 3629, 3630, 3631, 3632, 3633, 3634, 3635, 3636, 3637, 3638, 3639, 3640, 3641, 3642, 3643, 3644, 3645, 3646, 3647, 3648, 3649, 3650, 3651, 3652, 3653, 3654, 3655, 3656, 3657, 3658, 3659, 3660, 3661, 3662, 3663, 3664, 3665, 3666, 3667, 3668, 3669, 3670, 3671, 3672, 3673, 3674, 3675, 3676, 3677, 3678, 3679, 3680, 3681, 3682, 3683, 3684, 3685, 3686, 3687, 3688, 3689, 3690, 3691, 3692, 3693, 3694, 3695, 3696, 3697, 3698, 3699, 3700, 3701, 3702, 3703, 3704, 3705, 3706, 3707, 3708, 3709, 3710, 3711, 3712, 3713, 3714, 3715, 3716, 3717, 3718, 3719, 3720, 3721, 3722, 3723, 3724, 3725, 3726, 3727, 3728, 3729, 3730, 3731, 3732, 3733, 3734, 3735, 3736, 3737, 3738, 3739, 3740, 3741, 3742, 3743, 3744, 3745, 3746, 3747, 3748, 3749, 3750, 3751, 3752, 3753, 3754, 3755, 3756, 3757, 3758, 3759, 3760, 3761, 3762, 3763, 3764, 3765, 3766, 3767, 3768, 3769, 3770, 3771, 3772, 3773, 3774, 3775, 3776, 3777, 3778, 3779, 3780, 3781, 3782, 3783, 3784, 3785, 3786, 3787, 3788, 3789, 3790, 3791, 3792, 3793, 3794, 3795, 3796, 3797, 3798, 3799, 3800, 3801, 3802, 3803, 3804, 3805, 3806, 3807, 3808, 3809, 3810, 3811, 3812, 3813, 3814, 3815, 3816, 3817, 3818, 3819, 3820, 3821, 3822, 3823, 3824, 3825, 3826, 3827, 3828, 3829, 3830, 3831, 3832, 3833, 3834, 3835, 3836, 3837, 3838, 3839, 3840, 3841, 3842, 3843, 3844, 3845, 3846, 3847, 3848, 3849, 3850, 3851, 3852, 3853, 3854, 3855, 3856, 3857, 3858, 3859, 3860, 3861, 3862, 3863, 3864, 3865, 3866, 3867, 3868, 3869, 3870, 3871, 3872, 3873, 3874, 3875, 3876, 3877, 3878, 3879, 3880, 3881, 3882, 3883, 3884, 3885, 3886, 3887, 3888, 3889, 3890, 3891, 3892, 3893, 3894, 3895, 3896, 3897, 3898, 3899, 3900, 3901, 3902, 3903, 3904, 3905, 3906, 3907, 3908, 3909, 3910, 3911, 3912, 3913, 3914, 3915, 3916, 3917, 3918, 3919, 3920, 3921, 3922, 3923, 3924, 3925, 3926, 3927, 3928, 3929, 3930, 3931, 3932, 3933, 3934, 3935, 3936, 3937, 3938, 3939, 3940, 3941, 3942, 3943, 3944, 3945, 3946, 3947, 3948, 3949, 3950, 3951, 3952, 3953, 3954, 3955, 3956, 3957, 3958, 3959, 3960, 3961, 3962, 3963, 3964, 3965, 3966, 3967, 3968, 3969, 3970, 3971, 3972, 3973, 3974, 3975, 3976, 3977, 3978, 3979, 3980, 3981, 3982, 3983, 3984, 3985, 3986, 3987, 3988, 3989, 3990, 3991, 3992, 3993, 3994, 3995, 3996, 3997, 3998, 3999, 4000, 4001, 4002, 4003, 4004, 4005, 4006, 4007, 4008, 4009, 4010, 4011, 4012, 4013, 4014, 4015, 4016, 4017, 4018, 4019, 4020, 4021, 4022, 4023, 4024, 4025, 4026, 4027, 4028, 4029, 4030, 4031, 4032, 4033, 4034, 4035, 4036, 4037, 4038, 4039, 4040, 4041, 4042, 4043, 4044, 4045, 4046, 4047, 4048, 4049, 4050, 4051, 4052, 4053, 4054, 4055, 4056, 4057, 4058, 4059, 4060, 4061, 4062, 4063, 4064, 4065, 4066, 4067, 4068, 4069, 4070, 4071, 4072, 4073, 4074, 4075, 4076, 4077, 4078, 4079, 4080, 4081, 4082, 4083, 4084, 4085, 4086, 4087, 4088, 4089, 4090, 4091, 4092, 4093, 4094, 4095, 4096, 4097, 4098, 4099, 4100, 4101, 4102, 4103, 4104, 4105, 4106, 4107, 4108, 4109, 4110, 4111, 4112, 4113, 41

THURSDAY, MARCH 19, 1908.

COAL MINING.

Practical Coal Mining. By Leading Experts in Mining and Engineering. Edited by W. S. Boulton. Vol. ii., pp. vi+161-348; vol. iii., pp. viii+192; vol. iv., pp. viii+193-404. (London: The Gresham Publishing Company, 1907.) Price 6s. net each.

IN NATURE of May 23, 1907, a notice was published of the first instalment of this work, which, when completed in six volumes, is intended to cover the whole ground of modern coal-mining practice. Three further volumes have been received, containing the conclusion of Prof. H. Louis' section on shaft sinking, which broke off in the middle of a paragraph, and sections on breaking ground by Mr. H. F. Bulman, on methods of working and timbering by Mr. E. H. Robertson, on haulage by Prof. G. R. Thompson, on winding by Prof. C. Latham, on pumping by Mr. W. E. Lishman, on ventilation by Mr. H. W. G. Halbaum, and on transmission of power by Mr. W. E. Lishman. This division of responsibility among many contributors renders a certain want of harmony in the treatment of the subject-matter inevitable. The work will, however, certainly prove as a whole a valuable addition to coal-mining literature.

The concluding instalment of the section on shaft sinking by Prof. H. Louis is excellent. Recent German experience of shaft sinking in difficult cases recorded by Riemer and other Continental authorities is set forth in concise form; details of cost hitherto unpublished are given, and the accompanying sixty-five illustrations, unlike most of the others in the work, have in every case an indication of the scale to which they are drawn.

The fifth section, on breaking ground, covering fifty-nine pages, contains much practical information on driving stone drifts and on coal-cutting machines. The details relating to explosives do not, however, exceed a few words, and no description is given of the rock drills employed in driving stone-drifts.

The sixth section, on methods of working and timbering, the most important branch of mining, covers only fifty-four pages, and the illustrations are not very happily chosen. Altogether this section does not compare favourably with the treatment the subjects have received in the existing treatises by Hughes, Pameley, and others.

The seventh section, on haulage, which forms the commencement of vol. iii., covers seventy-four pages, and has been carefully compiled; the information given regarding tubs, rails, haulage, roads and systems of haulage being concise, accurate, and up to date. Interesting details are furnished of the recent application of mechanical conveyors in the road leading from each working face to the level beneath in steep seams. In regular seams, not seriously disturbed by faults, much is to be hoped from the application of conveyor systems; but there will always remain a large number of mines in disturbed areas where the natural conditions preclude such systematic working, and thus

give scope to the ingenuity of the manager in arranging his system of secondary haulage.

The eighth section, on winding, covers ninety pages, and is adequate as far as it goes. Less hackneyed illustrations might have been selected with advantage, and more attention might usefully have been given to the great changes in winding that have taken place in recent years. The operating of main winding gears by electricity, for example, is dealt with in fifty lines. Winding by electricity is, it is true, little practised in Great Britain, although there is a large plant of 1500 horse-power in South Wales. In Germany, however, winding by electricity is making rapid progress. One firm alone has in hand about forty winding engines, some dealing with 2000 tons of coal per day and lifting from depths of 900 yards.

The ninth section, on pumping, covers 83 pages, and contains a concise summary of the recent literature on mine drainage, with well-selected illustrations of the principal types of pumps.

The tenth section, on ventilation, covers 80 pages, gives the principles on which the practice of mine-ventilation is based and discusses the theory of the centrifugal fan. The properties of mine gases and the instruments of measurement are also briefly dealt with.

The eleventh section, on transmission of power, deals first with electricity as the leading power agent, and then in turn with steam, compressed air, and hydraulic power. In this section various topics, such as winding, hauling, pumping, ventilation, and coal-cutting, are incidentally dealt with, the result being that there is a certain amount of clashing with previous sections. The Kaselowsky pump, for example, described on p. 403, is also described on p. 244 of the same volume.

The work is profusely illustrated, the three volumes containing 293 illustrations and twenty plates; and the type is large and clear. The ornate binding and the garish frontispieces are, perhaps, a little wanting in dignity for a comprehensive treatise on mining.

MALARIA AND NATIONAL DECAY.

Malaria. A Neglected Factor in the History of Greece and Rome. By W. H. S. Jones. With an introduction by Major R. Ross, C.B., F.R.S., and a concluding chapter by G. G. Ellett. Pp. vii+108. (Cambridge: Bowes and Bowes; London: Macmillan and Co., Ltd., 1907.) Price 2s. 6d. net.

THE subject of the rise and decline of nations and of the causes to which they are due is of perennial interest. One of the problems which historians have striven to solve is the great change in the Greek character which occurred during the fourth century B.C. To quote from Mr. Jones's essay:—

"Home life took precedence of city-life. Patriotism decayed, and lofty aspirations almost ceased to stir the hearts of men. In art there appeared a tendency to sentimentalism; philosophy in many quarters became distinctly pessimistic. Some schools of thought actually took 'absence of feeling' or 'absence of care' as the highest goal of human endeavour. Dissatisfaction and querulousness are marked charac-

teristics of the age. By 300 B.C. the Greeks had lost much of their manly vigour and intellectual strength."

In seeking for a cause for so remarkable a change the pregnant suggestion was made by Major Ross that widespread disease—particularly those "endemic diseases, which when introduced oppress a country for ever"—may have had far-reaching effects in modifying and moulding a new national character. Thus, in many of the southern States of America, the ill-health produced by widespread infection with the hook-worm has been held by American parasitologists to be largely responsible for the sloth and want of enterprise exhibited by the inhabitants of those districts. Recent investigations into the prevalence of malaria in Greece by Major Ross and others suggest that this disease may have been introduced into the country during the period mentioned, and may have been the factor bringing about this remarkable alteration of national characteristics. For malaria has not necessarily always been endemic in the districts in which it is now found. For example, Mauritius was free from malaria up to 1866, in which year it was introduced, and has caused infinite injury to the island ever since.

Mr. Jones has sought in the ancient authors for evidence which may serve to show when malaria was introduced into Greece, and what its effects may have been on the race, and has embodied the results of his researches in this interesting book. With two exceptions there seem to be no references in the classic writers to any disease which could be malaria before the middle of the fifth century B.C. It is in the "Wasps of Aristophanes" (422 B.C.) that the word *πυρετός* (used, generally in the plural, for malaria) first occurs in Greek literature (with a single exception in the "Iliad"). It is a singular coincidence that three years previously the Athenians were engaged on the island of Sphacteria, which is now one of the most malarial centres in the Mediterranean. The Peloponnesian war followed, large tracts of land were allowed to go out of cultivation, and it seems not unreasonable to conclude that the malaria parasites, introduced from Italy by Greek slaves or perhaps by the Carthaginians, then spread gradually over the country.

The word *μελαγχολία* and its cognates occur in Greek literature soon after the word *πυρετός* became common. Now the primary meaning of "melancholy" (derived from *μελαινα χολή*, "black bile") seems to have been "excitable" or nervous. In the medical writers, tertian and quartan fevers were said to be derived from yellow and black bile respectively. Galen says that "large spleens are caused by 'melancholy humour'" (humour being used in the sense of a morbid fluid), and Hippocrates remarks that cases of "melancholy" occur in the autumn, which is the malarial season. It would therefore seem that the "melancholy" of these early writers is malarial cachexia. Mr. Jones arrives at the conclusion that "malaria was certainly prevalent in many parts of Greece, including Attica, during the fourth century B.C., though Greece was not 'highly infected,'" and

that "the change which gradually came over the Greek character from 400 B.C. onwards, was one which would certainly have been aided, and was in all probability at least partially caused by the same disease."

In a similar manner the introduction of malaria into Italy is discussed, and it is inferred that this disease did not exist there much before 200 B.C., but was prevalent from 50 B.C. onwards. It seems plausible that it was introduced by Hannibal's Carthaginian mercenaries. As in Greece, so in Rome, it left its mark on the national character:—"Malaria made the Greek weak and inefficient; it turned the sterner Roman into a blood-thirsty brute—*atra bilis* made its victims mad."

Mr. G. Ellett contributes a final chapter, and among other points directs attention to the immunity from malaria enjoyed by progressive Japan contrasted with her stagnant neighbour China, where malaria is prevalent. Major Ross's foreword describes the manner in which malaria is disseminated by the mosquito, and some of the results of malarial infection, and serves as a fitting introduction to this interesting essay, particularly for the non-medical reader. Besides being interesting, the book has been issued with an object—to show how important it is to stamp out malaria wherever possible.

R. T. H.

ELECTRICITY OLD AND NEW.

Cours d'Électricité. By H. Pellat. 3 vols. Vol. i., pp. vi+329; price 10 francs. Vol. ii., pp. 554; price 18 francs. Vol. iii., pp. vi+290; price 10 francs. (Paris: Gauthier-Villars, 1901, 1903, 1908.)

Les Découvertes modernes en Physique. By O. Manville. Pp. iii+186. (Paris: A. Hermann, 1908.) Price 5 francs.

M. PELLAT has published the courses of lectures which he gave from 1898 to 1907, covering the whole science of electricity. The first volume deals with electrostatics, the second with currents and magnetism, the third with the later developments of electrolysis and gaseous conduction. The course is intended and suited for somewhat advanced students, and no limitations are placed upon the use of mathematics; for the most part, little attention is given to experimental arrangements.

In the case of a work by a physicist so distinguished as M. Pellat it is unnecessary to criticise details; accuracy and soundness in all essentials may be assumed. The only remarks which a reviewer can offer concern the method of treatment; and it is in this respect that M. Pellat's volumes call for comment, for the order in which the subject-matter is introduced is entirely unconventional. The author believes that the usual development is illogical, and has endeavoured to correct this fault.

Thus he refuses to develop electrostatics from the basis of Coulomb's law on the ground that, if that law is taken as the starting-point, some hypothesis must be introduced, when media of different dielectric constant are considered. Accordingly he starts from experiments with a Faraday cylinder and an electrometer, and only introduces Gauss's theorem and the

law of the inverse square after he has established almost all the important propositions. But any given proposition can only be established validly by any process of argument from an irreducible number of primary propositions or assumptions. If the assumption of which M. Pellat speaks is necessary to the development of the subject, then, if his arguments are sound, that assumption or its equivalent must be introduced at some stage. The difference between M. Pellat's treatment and that adopted ordinarily is not that the former requires fewer primary propositions than the latter, but that in the former those propositions are introduced as the direct consequence of some experiment, while in the latter they are introduced as hypotheses verified subsequently by the agreement of deductions from them with experiment. Now we insist most strongly that it is the latter process which is the more logical, for it is the process by which experimental sciences are actually developed. It is perniciously misleading to attempt to apply to such sciences arguments of the kind used in pure mathematics, for it is impossible to deduce any mathematical conclusion whatever from any experiment without an hypothesis; there is always an error of experiment. In our opinion, there are only two methods by which a science may be developed logically, neither of which is adopted by M. Pellat. The first is to follow the historical development, pointing out the stages at which hypotheses are introduced; the second is to define at the outset the concepts used and the propositions relating them, and to show that these lead to conclusions in harmony with experiment.

M. Pellat also prefers to develop electro-dynamics directly from the mutual action of currents, introducing the concept of magnetism as a subsidiary function, and then applying it to the phenomena of magnetic substances. His reason for this unconventional procedure is that magnetism is a fictitious quantity which does not exist, but only behaves as if it existed—a distinction too subtle for our comprehension. But here surely the author is abandoning his logical principles. Magnetism is only introduced into the study of current actions because the properties of permanent magnets happened to be examined before those of currents; if the historical order had been reversed, there would have been no need for the conception. If the author is ready to brave all the inconveniences that attend the ignorance of the history of the subject for the sake of logic, surely consistency to his scheme should make him abandon a notion so purely historical as magnetism.

Remark should also be made on M. Pellat's strange neglect of Maxwell's theory of the electromagnetic field. A complete description is given of Hertz's experiments on electric waves, but the theory on which alone they are intelligible is relegated to a few pages in an appended note. Rowland's fundamental research, proving the identity of the electrostatic and electromagnetic conceptions of a current, is referred to in a brief phrase and attributed to Röntgen and Hertz. In some other places the work shows a lack of proportion in the space that is given to different

subjects; twenty pages on electrostatic generators seems excessive, but on the other hand the chapter on dynamos and motors is excellent, and contains much that is too often excluded from physical textbooks. The last volume is on a somewhat different plane from its predecessors; it is more advanced, and contains discussions of many controversial points. We welcome an excellent last chapter on the elements of gaseous conduction.

It must not be thought that our remarks imply any disparagement of the work as a treatise for students; criticism has only been directed where it is challenged. English students are not so well provided in this subject that they would not welcome a translation. There is only one really serious defect in the book in its present form—the absence of an index.

M. Manville's book may be regarded in some respects as an attempt to supplement that of M. Pellat. The author complains that his countrymen have not realised yet the importance of the latest physical research. He thinks that they may have been hindered by the absence of a suitable summary which renders unnecessary reference to original memoirs, and has set himself to supply the defect. In less than 200 pages he treats of cathode and Röntgen rays, ionisation of gases, radio-activity, and general electron theory. Two subjects are also introduced which can hardly be termed modern; we should have thought that his exposition of the simple facts of electrolysis might have made way for more valuable matter, but apparently he is right in assuming that Maxwell's work has not been assimilated by those for whom he writes.

M. Manville's project is admirable, but we fear that his powers are not equal to his intentions, for he himself has not mastered these subjects completely. There are several actual mistakes, but a still more serious fault is to be found in his failure to show the connection between many of the phenomena which he describes. Though the various methods by which a gas may be rendered a conductor are treated in some detail, the only reference to the modern theory of ionisation, by which these methods may be correlated, is contained in a brief and inadequate paragraph at the end of the chapter. The account of the cathode rays is satisfactory, but there is no reference to the mechanism of the electric discharge in which they have their origin, nor is any distinction made between the electron and the ion which it forms. The chapter on radio-activity is a list of unconnected facts, while the theory of Rutherford and Soddy is dismissed as insufficient for the strange reason that it gives no account of induced activity! If not more than six pages could be spared for the application of the electron theory to optics, conduction and chemistry, it would have been better to leave such matters unmentioned. In view of recent speculations on the density and rigidity of the æther, it is hardly judicious to describe that medium as "ultra-gaseous."

As an example of actual inaccuracy we may quote the statement that solid dielectrics are ionised by Röntgen rays in the same way as gases. Our confidence in the author's analysis is shaken severely by

a calculation on p. 67, where the maximum current obtainable between two electrodes of constant potential difference, but variable distance, is deduced from the condition that the differential coefficient of the current with respect to the *time* should be zero.

French books are apt to err in matters of typography, but such an abundance of misprints and misspellings cannot be left unnoticed; Prof. Townsend comes in for specially hard treatment. On the other hand, we are accustomed to expect French authors to redeem these deficiencies by a graceful literary style; but M. Manville's aberrations would be hardly tolerated in England. It is with great regret that we have to express our opinion that a design contemplated so wisely should remain still in need of successful execution. N. R. C.

OUR BOOK SHELF.

The Oceanic Languages: their Grammatical Structure, Vocabulary, and Origin. By Dr. D. Macdonald. Pp. xv+352. (London: Henry Frowde, 1907.) Price 10s. 6d. net.

In this volume, Dr. Macdonald sets forth the proposition that the Oceanic languages originated in the Arabian peninsula, and are thus cognate with the Semitic tongues. The primitive Oceanic he regards as a sister language of Arabic, Himyaritic, Ethiopic, Assyrian, Phœnician, Hebrew, and Aramaic, and Efate, Samoan, Malagasy, Malay, &c., as cousins of the modern Semitic dialects. He regards the people speaking the Oceanic languages in Madagascar, the Malay Archipelago, Melanesia, and Polynesia as one great, though diversified, race or people, and the languages themselves as constituting one great family. This unity of race is, however, negated by the known ethnological data.

Although entitled "The Oceanic Languages," the work is mainly a dictionary of the Efate language of the New Hebrides, preceded by a discussion on the phonology, trilateralism, word-building, pronouns, and particles of the same language. These grammatical elements are compared with those of the Semitic languages taken collectively, so as to show a correspondence of forms. There is no attempt to give a comparative grammar of the Oceanic languages, though some few languages of the region, mainly Malagasy, Malay, other New Hebrides dialects, and Polynesian, are dealt with partially. In the absence of a comparative treatment of the Oceanic languages, some statements, such as those relating to the loss of gender in Oceanic pronouns (p. 75), the modern use of plural pronouns for singular, the representation of the Semitic nunation by final *na* or *n* in Malagasy and Malay (p. 92), are open to doubt, and cannot be accepted without some adequate proof being given.

The work is well printed, but it would have been better to print all the Semitic words in Roman character instead of occasionally using the Ethiopic, Syriac, Arabic, or Hebrew characters without transcription. In the preliminary (grammatical) part of the book there is a large amount of cross-reference, by which the illustration of some statement has to be sought in hundreds of places in the body of the book. In the dictionary, comparison of the Efate words is more fully made with the Semitic than with the Oceanic tongues, and here there are also numerous cross-references.

In conclusion, it may be said that the similarity of form in words and particles which Dr. Macdonald

has shown in Efate and Semitic is no proof that they were originally the same, and exactly the same method has been employed to affirm the relationship of the Oceanic languages to Aryan, Australian, and American. The history of the Oceanic languages, as a whole, must be traced out before the apparent affinities of one of them can be held to establish a relationship of the whole group to some other linguistic group. S. H. R.

Searchlights: their Theory, Construction, and Application. By F. Nerz. Translated by Charles Rogers. Pp. vii+137. (London: Archibald Constable and Co., Ltd., 1907.) Price 7s. 6d. net.

The use of searchlights has rapidly extended during recent years, with the result that the want of a good treatise, dealing with their principles of construction and the methods of using them, has made itself acutely felt. The volume at present under review is a translation of the treatise on searchlights in Prof. Voit's "Sammlung elektrotechnische Vorträge," but much new matter has been added, so that it now forms an epitome of the latest practice. After dealing with the optical principles utilised in the construction of searchlights, special attention being paid to parabolic mirrors, the performance of searchlights and the methods of testing their mirrors are discussed. The applications of searchlights in the field, in land fortresses, for coast defence, and on battleships then receive attention. For field purposes a light equipment is now obtainable, consisting of a waggon carrying a petrol motor and a dynamo, coupled to another waggon which carries the searchlight and a transportable tower for elevating it. Searchlight equipments for fortresses may be either fixed, partially movable, or wholly movable; each type receives adequate consideration.

For coast defence, special arrangements, such as dispersers, are sometimes required, and these, in their turn, necessitate special protecting devices. Searchlights are indispensable to a battleship; without their aid a night attack of torpedo boats could not be repelled, hence the application of searchlights to naval purposes receives very careful consideration. The details of construction are then described and illustrated, attention being paid to the different forms of arc lamp, their method of control, and the various optical accessories which form part of a complete equipment. The scientific principles utilised are so carefully and lucidly explained that they will be readily understood by one who has previously had little acquaintance with them. Various forms of transportable power supply are described and illustrated in the last chapter, and the book ends with an appendix which briefly describes the physical units used in photometry. No book could meet the want which led to its compilation better than this one does. E. E.

Beyond Good and Evil. Prelude to a Philosophy of the Future. By Friedrich Nietzsche. Authorised translation by Helen Zimmern. Pp. xv+268. (Edinburgh and London: T. N. Foulis, 1907.) Price 5s. net.

"ALL prudent, worldly wise men follow more or less approximately the practice which Nietzsche teaches, notwithstanding the opposite principles which they perhaps profess to hold," says Mr. Thomas Common in an introduction to this translation, and it will interest and instruct those who are unfamiliar with Nietzsche's philosophy to read what the philosopher has to say here on the natural history of morals and other subjects. No reader will complain that there are not questions enough for thought raised.

LETTERS TO THE EDITOR.

[The Editor does not hold himself responsible for opinions expressed by his correspondents. Neither can he undertake to return, or to correspond with the writers of, rejected manuscripts intended for this or any other part of NATURE. No notice is taken of anonymous communications.]

The Habitability of Mars.

INASMUCH as Dr. Wallace has sent me his book through his publishers, as I gather from the wrapper—though it is not so expressed—I suppose it is incumbent on me to acknowledge it, since he clearly expects some sort of reply. The effect of its perusal is to show me again how cogent is the argument for the habitability of Mars, for only by many misstatements of fact, wholly unintentional, of course, can Dr. Wallace make out even a seeming case upon the other side. A physicist will not need to have these errors pointed out to him, but as most readers are unable to correct them for themselves it may be wise to instance a few to show how his house of cards tumbles down in consequence.

On p. 22 he quotes from Miss Clerke to prove that the cap could only supply 2 inches of water over the irrigated districts. Let us assume her own estimate of snow deposited, and merely correct her mathematical and topographic mistakes. She states the maximum area which the cap covers to be 2,400,000 square miles. Now the south cap comes down to $36\frac{1}{2}^{\circ}$ latitude on the average, and an easy calculation shows this to occupy 11,330,000 square miles, or to be more than four times as great. Next, she supposes the natural dark areas of the planet to be irrigated, which they are not, mistaking them for the canal system, which, instead of 17,000,000 square miles, covers, oases and all, only about 4,750,000 according to our measures, remembering that the whole of it is not watered from one cap. By combining these two corrections we find, not 2 inches of water for each bit of ground, but $2\frac{1}{2}$ feet, and this according to her own estimate, which there is no reason to suppose not to be two or three times too small. So that it is the argument of Dr. Wallace, aid not the cap, that fails to hold water.

An equally fatal flaw affects Dr. Wallace's argument for temperature. Here he bases his deduction on a misstatement of Prof. Poynting. Prof. Poynting states that in my paper on the mean temperature of Mars I took no due account of the blanketing effect of air. Not only did I expressly take it into account, but I did so in the only way it can correctly be taken, not by hypothesis, but by direct appeal to what takes place on earth under a clear and under a cloudy sky by night; and I am glad to know that in a paper he has sent to the *Phil. Mag.* on the subject Prof. Very, the bolometric authority on matters of temperature to-day, agrees with both my method and my conclusion for Mars, and points out where Prof. Poynting's calculations are fallacious.

Another omission is no less telling. Dr. Wallace apparently is unaware that Prof. Very's bolometric determination of the moon's heat, which for delicacy surpasses any previous ones, makes the temperature on the moon during the lunar day reach 350° F. above Fahrenheit zero.

Many more such misunderstandings might be mentioned occurring throughout the book, such as where, from not giving its context, he makes me appear to say that water-vapour is one of the heavier gases, which, of course, I did not.

Again, his theory, taken from Chamberlin, that the interior of Mars can have completely lost its heat in the very process of contraction, and yet later have suffered a meteoric bombardment sufficient to give it a heated outer layer, is mechanically whimsical, not to say impossible. For it can be shown that Mars could not have captured any meteoric swarms not substantially travelling in its own orbit when it coalesced into a planetary mass, and any meteors subsequently encountered could only have fallen on it as it passed through a swarm, yielding a relatively insignificant amount of matter. Any such effect would be even more pronounced on the earth, of the occurrence of which there is no evidence.

Misstatements cannot be too carefully avoided in science,

especially when a man, however eminent in one branch, is wandering into another not his own. Dr. Wallace, whose intentions are of the highest, will appreciate this. Indeed, if criticism were confined, as common-sense counsels, to those versed in the phenomena, we should hear very little about the inhabitability of Mars.

Boston, March 6.

PERCIVAL LOWELL.

DR. J. W. EVANS's letter in NATURE of February 27 seems to invite notice from me in respect to three of the subjects with which it deals.

(1) As regards temperature. In most physical problems temperature may be regarded as a single definite measurement, which I understand to be Dr. Evans's point of view; but this ceases to be legitimate in molecular physics whenever the behaviour of an individual molecule comes under consideration. Temperature has then to be recognised as not one, but many, measurements, chiefly of two groups of activities, one group associated with the events that go on within the molecule and are in touch with the activities of the aether, and the other group mainly concerned with the journeys of the molecule through space and with one section of the events that occur during each of the encounters to which it may have to submit. Dr. Evans will find this subject referred to, and partly dealt with, at p. 76 of the *Astrophysical Journal* for July, 1904, or in the *Phil. Mag.* of the preceding month. On the other hand, in molar physics (as also in the kinetic theory of gas as usually treated) we have no occasion to deal with individuals; we are only concerned with swarms of molecules acting on one another and changing their behaviour so frequently that the activities of or within the molecules come into operation in too rapid succession to be distinguishable. All that we can then detect is that these numberless activities furnish an average outcome of energy which fortunately is (except in certain critical instances) sufficiently steady to admit of measurement, and is then what we call the temperature. But this jumbling together of unlike activities is not admissible when the question is about individual molecules—as when our object is to learn the conditions under which the lightest gaseous molecules of an atmosphere, which are those most violently tossed about, can occasionally and one by one drift away from their atmosphere.

(2) The question whether we can know that Mars is unable to prevent the escape of water is in effect almost the same question as whether we may trust the evidence that helium is in process of escaping from the earth, inasmuch as the dynamical conditions in these two problems are nearly identical. The evidence in the case of helium, so far as it was known eight years ago, Dr. Evans will find on pp. 369, &c., of the *Astrophysical Journal* for June, 1900. It should be added that the discoveries since that date about helium have materially strengthened the evidence then available.

(3) Dr. Evans bases an argument on the early state of the earth, which he thinks could not have been followed by the presence of water in modern times if some molecules can now escape from a planet in the way I have supposed. This, I believe, is a mistake. In the remote past the potential of attraction of the dilated earth of those days may have been, as supposed by Dr. Evans, so much less than now that multitudes of molecules now on the earth were not then upon it. So much may be conceded. But then, as now, these molecules were under the influence of the sun's attraction, and did not range beyond a ring round the sun, in which the earth also travelled—like the rings of Saturn or the asteroids of the solar system. Afterwards, when the earth shrank and the potential of its attraction rose to near its present amount, such of these molecules as encountered the earth were unable to escape again, and we now find them upon the earth. There is therefore no such conflict as Dr. Evans supposed between this possible past and the argument I have based upon observed facts, viz. upon the absence of all the gases of its atmosphere from the moon, and on the escape from the earth of molecules of hydrogen and helium which is still going on.

The more deductive method of investigating the escape of gases from atmospheres, without the premisses from

observation of which I have latterly made use—which deductive method I attempted in former times, and upon which others have relied since—will, I am persuaded, continue to be incompetent to deal with this real problem of nature unless man's knowledge of molecular physics receive such unhelped for accessions as will enable him to trace the history of single molecules. Meanwhile, what I advocate is that we avail ourselves of the mixed method, which introduces data established by observation to supplement the deductive method at the point where the deductive method fails.

G. JOHNSTONE STONEY.

30 Chestow Crescent, W., March 6.

Postscript, added March 13.—NATURE of yesterday's date announces the last supposed spectroscopic detection of water vapour upon Mars by one of Prof. Lowell's assistants. Observations of a like kind had been recorded by Sir Wm. Huggins and Prof. Vogel, and the wave-lengths of three of the lines observed were measured by Vogel, two of which may possibly be water lines recorded by Rowland, but not the third.

On the other hand, Campbell and Keeler in a better climate did not see them. Now, however, they seem to have appeared again. This would be the behaviour of a very variable coloured vapour like NO_2 ; and what I should desire is that an adequate study be made of the absorption spectra of the several such vapours which are unable to maintain themselves in our atmosphere on account of the presence of water, but are presumably to be found on Mars if water does not exist on Mars, and which if present will account for the orange colour of large tracts upon that planet, and for the variations of its colour at different seasons which are conspicuous.

It is to be regretted that the observers to whom we owe so much—from Schiaparelli to Lowell—have kept in view only one of the competing views as to the state of things on Mars instead of at each step considering them both, especially as the one they have preferred is that which some physicists have felt to be the least probable.

G. JOHNSTONE STONEY.

The Isothermal Layer of the Atmosphere.

LIKE Dr. Chree (p. 437) I have had experience of the vagaries of self-recording instruments, but I have generally been able to trace them to some remediable defect in the instrument or to the ignorance or carelessness of those who use them. I fancy that the man who constantly uses a certain instrument, and uses it intelligently and not by mere rule-of-thumb, has a fairly correct notion of the magnitude of the errors to which it is liable. If not, what reliance are we to place on any instrumental observations?

It is quite natural, however, to doubt the observations, and when this investigation first commenced I confess that I did the same. Now that hundreds of ascents have been made with different instruments, in different countries and in widely different circumstances, and all the results obtained are in striking agreement, such a view seems to me to be quite untenable. It is true that different instruments sent up with the same balloon have given widely different temperatures, but the results have been published, not concealed, and the instruments improved. I ascribe these discrepancies, which are the exception, not the rule, to solar insolation, which we avoid in England by making our observations after sunset.

With regard to the general question, the difficulties of registering a true temperature are two:—(1) stagnant and unmixed air which may be at different temperatures in different parts of the same garden; (2) the proximity of bodies of large thermal capacity, which by radiation and convection mask the true air temperature. Kites and balloons when they have left the earth are free from these errors, excepting that No. 1 applies to a balloon which does not burst when swimming at its highest point. Since, however, stagnant air does not matter provided sufficient time is allowed, and in this case time is allowed, I do not see what source of error there can be save solar insolation.

My belief in the accuracy of the thermometric results obtained in England is based on inference from the following facts. If a good trace, together with the constants of

the instrument, is given to two persons, they, working quite independently of each other, will get practically identical results. If the trace and instrument only be given to two persons, they, each calibrating the instrument for himself, will obtain similar results for temperature within the limits stated, but the agreement for height may differ by a kilometre or more in the higher parts. Hence I believe in the accuracy of the temperatures; but do not claim any great accuracy for the heights.

Now with reference to Dr. Chree's questions.

(1) Each station is held responsible for the accuracy of its own results, and I am not acquainted with the routine pursued at each individual station, but the general practice certainly is to test each instrument in spirit cooled by solid CO_2 both before and after each ascent.

(2) Answered above.

(3) No. The instruments used on the Continent are expensive, and being heavier require a more expensive balloon, and we have no funds with which to meet the expense, especially when it is remembered that balloons and instruments in England are lost about three times out of ten. We hope that this will be done on the Continent before long.

W. H. DINES.

Classification of Secondary X-Radiators.

IN NATURE of February 13 there is a letter by Dr. C. G. Barkla and Mr. C. A. Sadler in which the authors divide the elements—according to the qualities of the secondary X-rays emitted by them—into four groups founded upon the atomic weights, without consideration of any other quality of the element. It may be of interest to mention that practically the same classification was given by me as early as 1896 in the *Naturwissenschaftliche Rundschau* (vol. xi., p. 485), and that this classification was also dealt with in a treatise published by Prof. Voller and myself in the *Annalen der Physik und Chemie* (vol. lxi., p. 88, 1897). To this treatise there is added a table printed directly by the secondary rays of a great number of elements, and this shows not only the great difference between the elements of the different groups, but also the agreement in the behaviour of the various elements of the same group.

B. WALTER.

Hamburg, Physikalisches Staatslaboratorium,

March 2.

Gods and Godlings.

LEST some readers should infer from your obituary note on Sir Denzil Ibbetson (March 12, p. 443) that this distinguished anthropologist invented the word "godlings" for the rural deities of India, it is worth noting that "godling" was good English in the sixteenth century, and has never been allowed to drop. The Philological Society's "New English Dictionary" quotes Lambard's "Perambulation of Kent" (1570-6) on raising altars "to this our newe found Godlyng"; and examples from Drummond of Hawthornden, Dryden, and Peter Pindar show the convenience of the word. Coleridge preferred "godkin" for a minor deity with masculine attributes, but sanctioned "goddessling." Charles Colton in 1675 permitted a certain cult of "little Goddikkins"; Coventry Patmore regarded "godlet" as the more dignified appellative. Anthropologists have therefore had a fairly ample choice; but it should be added that in some of the above examples, at least, Dr. Murray and his coadjutors suspected a "jocular" intention.

DAVID PATRICK.

Edinburgh, March 14.

Tabulated Values of Certain Integrals.

IN NATURE, October 24, 1907 (p. 639), the integrals $x = \frac{k}{2} \int \cos u^2 du$ and $y = \frac{k}{2} \int \sin u^2 du$ are given. I shall be grateful if any of your readers can inform me where I can obtain tables of the numerical values of these integrals, or any other tables that will reduce the labour of the numerical calculation of them.

C. E. ADAMS.

9 Telford Terrace, Oriental Bay, Wellington,
New Zealand, January 18.

CANADIAN GLACIERS.¹

IN Dr. Sherzer's elaborate memoir on five glaciers in the Canadian Cordillera, we have a contribution to the study of ice-streams not less important than that recently undertaken by the Indian



Photo.

FIG. 1.—Illecillewaet Glacier in 1893.

Notman and Son, Montreal.

Geological Survey, which was recently noticed in these columns (p. 201). Easy of access, and thus well adapted for study, these Canadian glaciers lie between the 51st and 52nd parallel, that is to say, very nearly on the latitude of London; two of them, the Victoria and the Wenchemna, being east of the continental divide, the third, the Yoho, west of it, while the Illecillewaet and the Asulkan glaciers are in the Selkirks. The peaks of each range often vary from ten to eleven thousand feet in elevation, rarely exceeding the latter, and though they form rather more continuous walls and exhibit less contorted strata, remind us of the Swiss Oberland, west of the Kandenthal. The ranges, in fact, are carved out of stratified rocks, the deposition of which began quite early in the Cambrian period (the crystalline Archaean floor being invisible in this region) and continued through Palaeozoic and Mesozoic ages until the end of the Laramie. Then this enormous mass of sediment, supposed to measure from ten to twelve miles in thickness, was slowly bent up into a very broad and flattened arch—designated, inappropriately as we think, by the modern mongrel term, a peneplain—which was duly carved into peak and valley by the ordinary forces of subaerial erosion. Through Cenozoic (*sic*) ages until the beginning of the Pleistocene (why the diphthong should be

abolished in one name and retained in the other we fail to understand) rain and rivers were the chief sculpturing agents, but with the latter, ice began to make its mark on the rocks. There was, in fact, a Glacial epoch here as well as in the European Alps, and Dr. Sherzer tells us that signs are found of two, and one case of three, advances of the ice, followed by retreats. We should have welcomed a rather more precise description of the materials deposited on these occasions than is conveyed by the terms "till" and "ground moraine," because the identification of the latter is often, as we know from experience, a function of the writer's imagination, but we infer that in this case the deposits alter in character as the distance from the present ends of the glaciers increases, much as they do in the Alps of Europe.

In the case of each glacier, very careful observations have been made on the present position of its end, the signs of advance or retreat, the nature and quantity of moraine, and the structure and other physical properties of the ice. No one of them is really large, the Victoria, of which the fullest description is given, not exceeding more than about three miles in length. Starting at Abbot's Pass on the divide, its ice emerges from beneath the snow about 2000 feet lower down, and melts away after descending about 1500 feet more. According to the description,



FIG. 2.—Illecillewaet Glacier in 1905, from approximately the same view-point as Fig. 1.

it exhibits all the features usual in an Alpine glacier—crevasses, moulins, stratification, blue bands, shear planes, a granular structure, and sometimes even the disputed capillary tubes. Observations were made to determine the rate of movement, which, if

¹ "Glaciers of the Canadian Rockies and Selkirks (Smithsonian Expedition of 1904)." By Dr. William Hittell Sherzer. Pp. xii+135. (Washington: Smithsonian Institution, 1907.)

these be confirmed, is unusually slow, a maximum of 63 feet a year.

The Wenckhemna receives the name of a Piedmont glacier, rather on the Bottom's dream principle, for, though formed by the lateral union of several short ice-streams (called "commensal" because they are fed from different sources), they come to an end high up in a mountain valley. The Yoho glacier, on the west side of the divide, is split into two by a rocky rib at its lower end, and is unusually free from surface débris. The Illecillewaet glacier, best known of those in the Selkirk, with its steep cascade of shattered *séracs*, forms an imposing feature in the landscape, but, as a comparison of the accompanying figures plainly shows, retreated considerably between 1888 and 1905. The Asulkan glacier is the smallest and most southern of the five, but is nevertheless a fine object.

Lakets, moraines, and other "leavings" of the ice show that all these glaciers have retreated in comparatively recent times, but more facts must be gathered before the periodicity of their movements can be ascertained. It is, however, as Dr. Sherzer points out, not unlikely to agree with the approximate thirty-five and a half years already inferred for other districts, and we may notice in passing that in these mountains the "Chinook" wind is a substitute for the Alpine "Föhn." He claims for glaciers a certain amount of erosive action—the scooping out of small lake-basins in favourable circumstances, and the conversion of valleys in their lower parts from V-shaped into U-shaped. The latter may be; but we cannot help remarking that in the Alps, where the ice at equal distances can hardly have been less in quantity, it seems to have been singularly incapable of effacing any pre-existent feature of importance. Dr. Sherzer also claims that ice can exercise a plucking action, but apparently only when passing over a much-jointed quartzite. Obviously, this would be the worst possible material for making *roches moutonnées*, but even here we should like a little more proof that the glacier has mastered the "art of pluck."

The so-called "bear den" moraines—piles of coarse broken rock without the usual infilling of fine material—seem to be one of the more exceptional features of this region. Dr. Sherzer regards them as records of "landslides" upon the ice from the higher peaks. That would explain their structure, but we doubt whether an earthquake is needed to start a "berg fall." Not to mention earlier instances, those near Elm in the Serfnthal and from Turtle mountain in Alberta occurred without any seismic disturbance. The prismatic structure in "ice dykes" is also remarkable, and recalls that exhibited in *glacières* and pond-ice—a subject once much discussed, among other places, in the first and second volumes of NATURE. On the whole, though sometimes, perhaps, a little too diffuse in describing the well-known, Dr. Sherzer has made a valuable and remarkably well-illustrated contribution to the literature of glaciers.

T. G. BONNEY.

THE FORTHCOMING MATHEMATICAL CONGRESS AT ROME.

AS was announced in NATURE for February 6, the fourth International Congress of Mathematicians will be held at Rome in the week before Easter. The congress meets once every four years, the previous places of meeting being Zürich, Paris, and Heidelberg. On this occasion the order of proceedings will be as follows:—

Sunday, April 5; Reception at the Aula Magna by

the principal of the University, at 9.30 p.m. Monday, April 6: Inaugural meeting at 10 a.m. at the Capitol, at which Prof. Volterra will read a discourse on Italian mathematics in the last half of the nineteenth century. At 3 p.m. a general meeting will be held at the Reale Accademia dei Lincei for the election of a president and for the award of the Guccia medal, followed by two lectures. From Tuesday, April 7, to Saturday, April 11, the congress will meet in four sections every morning at 9 a.m., the subjects of the sections being (1) arithmetic, algebra, and analysis; (2) geometry; (3) applied mathematics; (4) philosophy, history, and teaching of mathematics. In the section of applied mathematics the subject of actuarial mathematics will be introduced by Prof. Toja for the first time at these congresses. On each of the afternoons of April 7, 8, and 10, two lectures will be given, commencing at 3.30 p.m. Thursday, April 9: Visit to the Palatine by invitation of the Minister of Public Instruction, at 3 p.m. Saturday, April 11: Concluding general meeting; arrangements for date and place of next congress. Ninth and tenth lectures. Sunday, April 12: Visit to Hadrian's villa and lunch at Tivoli.

In addition, a reception will be given by the municipality in the museum of the Capitol on some evening during the week.

The lectures arranged are as follows:—Darboux (infinitesimal geometry), Forsyth (partial differential equations of the second order), Hilbert (method of infinite number of independent variables), Klein (the "Mathematical Encyclopædia"), Lorentz (partition of energy between matter and ether), Mittag-Leffler (representation of functions of a complex variable), Newcomb (lunar theory), Picard (analysis and mathematical physics), Poincaré (subject to be announced), Veronese (non-archimedean geometry).

From March 25 to May 5 the Italian State railways will issue tickets at reduced fares to those attending the congress from the frontier stations, as well as for ten separate journeys in any part of Italy. In addition, all members are granted free admission to the principal museums and galleries in Rome between April 1 and April 12. The subscription is fixed at 25 lire (1*l.*) for members, or 15 lire for those belonging to the family of a member who desire to enjoy the same privileges; but to obtain railway vouchers for the outward journey subscriptions have to be received before March 25 by the treasurer, Prof. Vincenzo Reina, 5 Piazza S. Pietro in Vincoli, Rome.

From the point of view of the English mathematician, the time fixed for the congress this year is somewhat inconvenient, as those who attend will doubtless wish to see something of Rome at the same time, and not only are our Easter vacations, as a rule, very short, but in many cases they do not even cover the period fixed for the congress. These difficulties could have been obviated by holding the congress at its more usual time in the summer vacation, and had this been done no inconvenience would probably have been experienced from the heat, though some people might have been deterred from attending owing to fears in this respect. In view of the fact that only seven Englishmen attended the last congress, it is important that everyone who can attend should do so this time, even if this involves an extension of their holiday beyond the ordinary limits of the school or college vacation. It would be a great pity if anyone were debarred from attending these gatherings merely for the sake of a week's teaching to a class of elementary pupils, and it is to be hoped that the governing bodies of our schools and colleges will not allow such small obstacles to stand in the way of their mathematical representa-

tives being present on such occasions. Otherwise there is a danger of their mathematical teaching running into a narrow groove. In regard to future meeting-places of the congress, this matter is, of course, decided at the final meeting in April, but it may not be out of place to express the hope that the congress of 1912 will be held somewhere within the British Isles.

G. H. BRYAN.

PREHISTORIC CHEMISTRY.

ANCIENT Egypt always exercises an intense fascination for the student of the past, particularly as its written records are amplified by its "human documents" in the shape of mummies. This interest has, during the past few years, been intensified by the valuable series of anatomical studies on mummified remains which have issued from the Government School of Medicine at Cairo under the auspices of Prof. Elliot Smith. Not the least important of these is from the pen of Mr. W. A. Schmidt,¹ who has investigated mummified material of different epochs from the chemical and biological point of view. Some of the mummies he worked with carry us back to prehistoric periods, 6000 years ago, before the art of embalming as practised in later times was known to the inhabitants of the Nile valley.

It is remarkable that, in spite of this lapse of time, organic materials, which of all others are liable to decay, should still manifest in the test-tube their characteristic reactions. The presence of solid and volatile fatty acids, proteins, and cholesterol, with traces of intact fat, was demonstrable. The high percentage of fatty acids leads the author to the conclusion that they originate, not wholly from fat, but mainly from the body proteins. The formation of adipocere in the muscles of corpses left in water or buried in damp soil was adduced by the French observers in their work at the Morgue in Paris as evidence of the possible conversion of protein into fatty material. At the present time, however, the doctrine of the metabolic change of protein into fat is regarded with scepticism by most physiologists, in spite of the large amount of fatty acid radicals in the protein molecule.

The mummy protein, although it retains the general characters of albuminous material, has lost those specific properties which enable us to distinguish that of human origin from that which is found in other parts of the animal kingdom. In other words, it no longer gives what is termed the "biological reaction." This is disappointing, although it was doubtless expected. Mr. Schmidt also found that he could no longer detect hæmoglobin, and the substance regarded as blood by previous observers was doubtless composed of coloured gum and resin employed in embalming. In reference to the process of embalming itself, he was unable to find any soda; the so-called natrium bath really consisted of a solution of common salt. The old Egyptians simply pickled their corpses in brine, and the various balsams used were mere accessories which could have exerted no real influence on the process of mummification. The real agent at work here was undoubtedly the extraordinarily dry climate of Egypt, and it is this also which has acted as a preservative of the organic material which can still be identified.

The research reminds me of a small piece of work which was carried out by Dr. Otto Rosenheim² in

¹ "Chemische und biologische Untersuchungen von ägyptischen Mumienmaterial, nebst Betrachtungen über das Einbalsamieren; gesehen an der alter Agypten." (Published in Max Verworn's *Zeitsch. f. allg. Physiol.*, vol. vii., pp. 269-324, 1907.)

² "Chitin in the Carapace of the *Pterygopus osiliensis* from the Silurian Rocks of Oesel" (*Proc. Roy. Soc.*, vol. lxxvi., B, pp. 398-400, 1905).

my laboratory a few years ago. Small pieces of the carapace of a fossil Eurypterid were placed at his disposal by Sir E. Ray Lankester and Mr. Bather, of the Natural History Museum, and he was able to demonstrate in them the presence of chitin, their organic substratum. In this case one was dealing with prehistoric material compared with which an Egyptian mummy is quite recent. This kind of work appeals to the imagination, and one can only hope that if it is continued, still further light and interest will be thrown on the records of past ages.

W. D. HALLIBURTON.

DR. H. C. SORBY, F.R.S.

ON March 9, Dr. Henry Clifton Sorby, F.R.S., died, aged eighty-two, at his residence in Sheffield. The news of his death, although not unexpected, was received in the city of steel with profound regret, and those who had had the privilege of knowing Dr. Sorby felt that science had lost one of her greatest sons and that Sheffield must now look back upon "another yesterday." It is a little difficult for many of the inhabitants of "steelopolis" to realise that never again can they see the familiar figure hurrying along with bowed head, or the grave face, with, in its eyes, that far-off look which sees things beyond the ken of most men.

It is more than a little sad for those who could venture to intercept him with a "Good morning, Doctor," to know that never more can they receive his semi-startled, ultra-courteous recognition and hearty handshake, or again hear the cheery, almost laughing "Good morning. How are you?"

Combined with a complete absence of self-consciousness, two great personal characteristics of Dr. Sorby (which much handicapped him from the worldly point of view of non-scientific honours) were modesty and an immovable love of truth. The characteristic last named somewhat dimmed the brilliancy and lucidity of his papers, since in an enunciation he could never bring himself to omit any possible or even improbable qualification concerning the accuracy of the particular theory he happened to be formulating from his observed facts.

As a speaker Dr. Sorby could not claim to be an orator, but he had, nevertheless, a peculiar style all his own, by means of which he fully conveyed his meaning to his sympathetic audiences. Dr. Sorby belonged to a past generation of men of science the like of whom the world will do well to breed again. He loved science for her own sake, but so far from holding the view that science applied was science degraded, his almost child-like pleasure on hearing that some of his discoveries had been of practical use in the great workaday world was good to see. Dr. Sorby was not a family man, and though in easy circumstances he laboriously devoted his life to scientific research. The fact that those services to science were never adequately rewarded remains a permanent disgrace to the powers that be.

Turning from personal matters to the works of this great man of science, the writer is confronted by the fact that he must attempt the impossible task of compressing into a few hundred words an account of the labours of a versatile genius spread over a period of nearly sixty years, and embodied in about 240 papers, a number which, taking into consideration the length of Sorby's scientific life, corresponds to an average of four papers *per annum*.

His first research on sulphur and phosphorus, in agricultural crops was published in 1847; his last paper on geology was written a few months before his death.

In 1849 Sorby founded the science of petrography, preparing in that year the first rock section ever examined by transmitted light. His alleged "wild ideas" as to the capabilities of this method were laughed at by the authorities of the period. Indeed, for a young man, not long past his teens, to attempt to upset the generally accepted dictum of de Saussure that mountains could not be examined by microscopes was regarded as bordering on presumption. In the early 'fifties, Sorby was much engaged on the subjects of the crystalline tetramorphism of carbon and the vexed question of slaty cleavage. In connection with the latter, in spite of rebukes, he persisted in his work, and in 1857 the young man of science buried both the electric and the 45° theories, by proving that slaty cleavage was due to the fact that lateral pressure on argillaceous rocks compressed them in one direction, elongated them in another, thus setting the small particles with their longest dimensions parallel, and so developing the characteristic structure in a plane perpendicular to the pressure.

In 1856 Sorby enunciated his now generally accepted theory that the Cleveland ironstone hills had been originally calcium carbonate, which had been gradually replaced by carbonate of iron derived from associated strata.

In the organic world Sorby did much work on colouring matters, and in this connection, for practical value, his microspectroscopic examinations of blood perhaps stand first. In 1865 he described his "new form of spectrum microscope" and the results registered thereby before the British Association. Proceeding upon information published by Hoppe, and two years later (1864) in greater detail by Prof. Stokes, Sorby exhaustively examined the microspectroscopic properties of red and brown cruorine and hæmatin, and from these figured no less than seven characteristic absorption spectra, showing incidentally that well-marked bands could be obtained from a minute blood-stain when only one-thousandth part of a grain of colouring matter was present. The importance of such marvellously delicate analysis was at once obvious to medical men and public analysts liable to be called upon to give evidence in criminal cases.

Sorby, the "Father of Petrography," was also destined to become the Father of Metallurgy.¹ His pioneer discoveries in petrography led him to the sagacious conception that steel itself might be a crystallised igneous rock; and in February, 1864, he placed in the hands of metallurgists for all time a new and most valuable method of scientific investigation.

On that date he read before the Sheffield Literary and Philosophical Society a paper "On a New Method of Illustrating the Structure of Various Kinds of Blister Steel by Nature Printing." In this paper he revealed the cellular structure of hard blister steel. He then attempted to produce artificial meteorites, but his efforts were not attended with success, because, as is known now, his experimental conditions were unsuitable, and it was not until 1904 that an "artificial meteorite" was described in NATURE on November 10, p. 32.

Sorby (as evidenced by the numerous carefully dated and initialled iron and steel sections now in the writer's possession²) worked on iron and steel metallurgy during the years 1863, 1864 and 1865,

and, taking into consideration the meagre chemical data then extant, his final theory as to the nature of steel seems almost of the order of inspiration. He described crystals of nearly pure iron as consisting probably of interfering cubes and octahedra, and after a lapse of nearly forty-three years the accuracy of his conclusions (with only sectional planes to guide him) remains unshaken. In his "pearly constituent" (now called pearlite) he discovered a mineral the importance of which to mankind is still in this, the steel age, imperfectly realised. His "intensely hard constituent" is the cementite of the modern metallographer. The pearly constituent Sorby described thus:—"The optical characters of this substance led me to conclude that it had a very fine laminar structure before I was able to prove it by the use of high powers. It seems difficult, if not impossible, to explain its structure by supposing that it is an accidental mixture, whereas the facts are easily explained, if we suppose that it exists as a *compound*³ at a high temperature, and breaks up into a *mixture* on further cooling, as more fully described in my paper on the use of high powers. For this reason it will be convenient to retain the name *pearly constituent* with the understanding that, as seen when cold, it is a mixture."

Persistent attempts to disprove the accuracy of Sorby's views of the nature of pearlite have, up to the present, consistently failed. Sorby's efforts to analyse pearlite quantitatively by micrographic means were, from the very nature of the problem, unsuccessful. He provisionally suggested that the hard plates constituted about 33 per cent. of the mass. Subsequent researches have shown that analyses on planes of section are misleading. The quantitative determination of the percentage and composition of these plates in pearlite occupied (in the metallurgical laboratories which were founded at Sheffield, largely owing to the energy and interest of Dr. Sorby) a period of three years, 1891-4, and was only accomplished by a triple attack conducted (a) by the microscope; (b) by quasi-quantitative pyrometric measurements of the heat of transformation of pearlite; and (c) by differential chemical analysis of the carbides as distinguished from carbon. The result obtained and now generally accepted indicated that in pure pearlite the percentage of hard plates always approximates 13.

It would occupy an inordinate amount of space even to summarise the results of Sorby's work conducted on his yacht *Glimpse* in connection with marine zoology. Dr. Sorby was a member of the Established Church, and made considerable researches in ecclesiastical architecture.

In concluding, it may be remarked that the final answer to the more or less good-natured derision with which his first rock section was regarded in 1849 was given, not by Dr. Sorby himself, but fifty-seven years afterwards by a cloud of witnesses at the centenary meeting of the Geological Society in February, 1906. Then many of the most distinguished foreign and British petrographers sent to the invalid man of science the following special message, expressing their "profound conviction of the important service rendered to the branch of geological science which they cultivate by the pioneer labours of Dr. Henry Clifton Sorby. They deplore the circumstances which prevent him from joining them on this interesting occasion, but beg to be allowed to assure him of their great admiration of his life's work, of their filial regard and deep affection."

Of Dr. Sorby it cannot be said that a prophet has no honour in his own country. Amongst the

¹ This is now known as hardenite (writer's note).

¹ The attempt made by an American writer to transfer this title to a Russian metallurgist is best answered by silence.

² Some years ago the writer was exhibiting Sorby's pioneer sections of iron and steel at the Royal Institution, and was asked by an interested spectator, "How much each are you asking for them?"

most treasured possessions of the University of Sheffield will always remain the marble bust of Sorby at the entrance to the Firth Hall, and his portrait, which hangs in the council room. So—his "task accomplished and the long day done."

"Beyond the loom of the last lone star, through open darkness hurled

Further than rebel comet dared or hiving star-swarm swirled

Sits he with those that praise our God for that they served His world."

J. O. A.

NOTES.

WE regret to learn at the moment of going to press of the death of Sir John Eliot, K.C.I.E., F.R.S., who until recently was the distinguished head of the Indian Meteorological Service.

At the anniversary meeting of the Royal Irish Academy on Monday, March 16, the following were elected as honorary members of the academy in the section of science:—Sir Archibald Geikie, K.C.B., F.R.S.; Prof. J. C. Kapteyn, Groningen; Prof. A. A. Michelson, Chicago; Prof. J. D. van der Waals, Amsterdam; and Dr. A. R. Wallace, F.R.S.

It is understood that provision will be made by the Canadian Government in the estimates for the coming financial year for a grant of 25,000 dollars (5000*l.*) by the Dominion Parliament towards the expenses of the British Association's visit to Winnipeg next year. The city of Winnipeg itself proposes to make a grant of 5000 dollars (1000*l.*). The week of the meeting will probably be from August 25 to September 1, 1909.

A MEMORIAL to the late Sir Leopold McClintock is to be placed in Westminster Abbey, with the consent of the Dean and Chapter. The memorial will consist of an alabaster slab, underneath the monument to Sir John Franklin, whose fate was definitely ascertained by Sir Leopold during his celebrated expedition on board the *Fox*. The inscription will be as follows:—"Here also is commemorated Admiral Sir Leopold McClintock, 1819-1907. Discoverer of the Fate of Franklin in 1859." The expense of the memorial has been undertaken by the Royal Society, the Royal Geographical Society, and Trinity House.

THE Canadian Mining Institute is arranging, in connection with its summer meeting, a general excursion to the mineral districts of Nova Scotia, Quebec, Ontario, and British Columbia, starting towards the end of August next. Members of the Institution of Mining and Metallurgy have been invited to take part in the general excursion (or any part of it) on the same specially favourable conditions as will be accorded to its own members. The Dominion Government, and the various provincial governments concerned, will cooperate in making the excursion a success, and the occasion will afford an excellent opportunity for engineers to inspect the important mineral areas of the Dominion.

THE second International Conference on Sleeping Sickness, to the proceedings of which attention was directed in our issue of last week, has terminated without being able to agree on the draft convention before it. Reuter's Agency states that the French and Italian plenipotentiaries declared themselves unable to accept a proposal, made at the last conference in June and then unanimously recommended, for the establishment of a central bureau in

London. It was proposed that the work connected with sleeping sickness should be taken over by a hygiene bureau to be established in Paris, but this proposal the German plenipotentiaries declined to accept, and they strongly supported the British plan for the establishment of a bureau in London. The president (Lord Strathcona), the vice-presidents, and council of the Royal Institute of Public Health gave a dinner on March 11 at the Hôtel Métropole "to meet the delegates of the International Sleeping Sickness Conference." Lord Strathcona presided, and in proposing the health of the delegates to the international conference hoped that the result of that and successive conferences will be, if not to eliminate, at all events to mitigate the great scourge of sleeping sickness. Dr. Koch, in reply, said it is but the duty of medical men to investigate diseases. Especially is this the case with countries which, on account of their colonies, are particularly interested in certain dangerous diseases. Dr. Cureau expressed the thanks of the French delegates. The Marquis de Villalobar, Prof. S. Liquido, Colonel Lantonnais, Dr. Kopke, and Sir Walter Foster also replied.

THE Bakerian lecture of the Royal Society will be delivered on Thursday next, March 26, by Prof. C. H. Lees, F.R.S., upon the subject of the thermal conductivities of solids.

WE have received a copy of the introductory number of *Neue Weltanschauung*, a scientific journal to be published at Stuttgart in monthly parts at fourpence each. It appears that a *Neue Weltanschauung* Society has been established at Stuttgart which is to issue, not only the monthly journal bearing the same name, but likewise another publication at irregular intervals. We shall be better able to judge of the merits of the former when we receive one of the regular numbers.

IN the March issue of *British Birds* Mr. N. F. Ticehurst records a number of bird-bones obtained by excavating an ancient mound known as the Broch of Ayre, near the Bay of Ayr, in Orkney. The most interesting of these is an imperfect leg-bone of the great auk, a species hitherto unknown from the Orkney mainland. It would, however, remarks the author, be rash to take the evidence of such a specimen as proof that the bird was once an inhabitant of the mainland.

NO. 1579 of the Proceedings of the U.S. National Museum contains an interesting account of the mode of collecting the sap of the Mexican agave and manufacturing therefrom the national beverage known as *pulque*. When the agave is in the proper condition some of the leaves are stripped away so as to expose the central core of unfurled leaves; a year later the core is cut out bodily, and a hollow made in the base to serve as a reservoir for the limpid sap, which soon flows from the wound, and is stated to have a taste very like cocoanut-milk. The sap, or *aguamiel*, is drawn off by means of a siphon, and transported in skins to undergo fermentation, and thus be converted into *pulque*.

WE have been favoured with a reprint of a note published in the *American Naturalist* for December last, in which Mr. F. T. Lewis disputes the commonly accepted view that the mimicry among South American butterflies is connected with birds. The original mimicry theory, it is explained, has been so extended as to embrace and account for not only resemblances between an edible and an inedible form, but also between two inedible species. The author now raises the question whether the re-

semblances have anything to do with edibility, or the reverse, and quotes Werner and Weismann to the effect that they have not. One of the arguments used is that, as a general rule, birds do not molest butterflies to any great extent. The real explanation of the resemblances in question will, in the author's opinion, be supplied by a chemical theory of animal coloration.

THE third part of the Bergen's Museum *Aarborg* for 1907 contains a long article by Mr. C. F. Kolderup on Scandinavian glaciation. At the period of greatest extension, it appears that the whole country was covered with an ice-sheet moving in a westerly direction altogether independent of local contours. When, however, the ice began to diminish, the direction of movement gradually became more and more dependent upon that of the valleys, until finally the ice-sheet became resolved into a number of large isolated glaciers filling the latter. Some geologists admit only one great ice age, and deny the intercalation of a warm period between two such maxima, during which the snow well-nigh disappeared from the Scandinavian highlands. The evidence of the moraines and their embedded shells is, however, in the author's opinion, amply sufficient to justify belief in such an intercalation. Indeed, the occurrence of several oscillations of level, with concomitant climatic changes, appears to be demonstrated.

THE Cotteswold Naturalists' Field Club has recently issued in part i. of its sixteenth volume a paper by Dr. C. G. Cullis and Mr. L. Richardson on the Old Red Sandstone conglomerate of the Forest of Dean, in which gold has undoubtedly been detected. A comparison with the "banket" beds of the Rand is made, favourable to the Forest of Dean so far as convenience in working goes; but the authors do not commit themselves as to the average gold-contents of the British deposit. The same part contains several papers on local geology, and a finely illustrated account of species of the terebratuloid genus *Cincta*, by Mr. S. S. Buckman. *Terebratula numismalis* here finds itself split up into a number of species of Quenstedt's genus *Cincta*, which has priority over several other names.

THE fourth part of vol. xx. of the Proceedings of the Geologists' Association (January, 1908, price 3s.) consists of a complete memoir by Dr. A. W. Rowe on the zones of the White Chalk of the Isle of Wight, with an index that includes all places and fossil species mentioned in this and in the four memoirs that have preceded it. Mr. C. D. Sherborn, who has often collaborated in this great zonal work, supplies coloured maps on a large scale, and the photographic illustrations are of extraordinary delicacy and beauty. Dr. Rowe's twelve years' labour is here brought worthily to a conclusion, and the necessity of accurate zonal collection, if one would study any sequence of fossil forms, is again set clearly before the reader. The true course of invertebrate evolution can, after all, be traced only by the painstaking methods of field observation inaugurated by William Smith at the close of the eighteenth century.

In the *Bolletino* of the Italian Seismological Society Prof. Mario Baratta gives a detailed account of the methods of construction adopted in re-building the Calabrian villages destroyed in the earthquake of September 8, 1905. Frame buildings in wood, filled in with masonry or concrete, were largely adopted, and armoured concrete for the more important buildings. The report would have been of greater interest had it contained an account of the behaviour of these erections in

the earthquake of October 23, 1907, which was said, in the daily newspapers, to have destroyed some of the newly built villages.

WE have received an advance copy of a paper by Dr. E. Oddone, to be published in the *Bolletino della Società Sismologica Italiana*, in which he makes the suggestion, already put forward by Prof. Milne in the last report of the British Association committee on seismological investigations, regarding the possibility of a causal connection between the two earthquakes on August 16, 1906, which occurred within about thirty-two minutes of each other, one in the northern Pacific, the other in Chile. This interval being approximately that which the wave motion of the second phase might be expected to take in travelling from the origin of the one earthquake to that of the other, it is suggested that the arrival of these waves was the determining cause of the time of occurrence of the Valparaiso earthquake. An objection to the acceptance of this suggestion is the uncertainty as to whether the second-phase waves are not extinguished before reaching a distance of 120° from the origin, that is to say, somewhat less than the distance separating the origins of the two earthquakes in question.

THE Queensland Geological Survey has issued a Bulletin (No. 216), by Mr. B. Dunstan, on the Great Fitzroy copper and gold mine, Mount Chalmers, Rockhampton district. The ore deposits, which have been known since 1860, occur in quartzite, which appears to be the result of the alteration of limestone. It is estimated that there is about 145,000 tons of ore still available, containing 4½ per cent. of copper, 3½ dwt. of gold per ton, and 1 ounce of silver per ton.

THE weathering of coal forms the subject of an investigation by Prof. S. W. Parr and Mr. N. D. Hamilton (University of Illinois, Bulletin No. 17). They find that an exudation of combustible gases from coal occurs from the time of breaking out of the sample from the seam, and that an absorption of oxygen accompanies the exudation. The process of deterioration is probably due to oxidation of hydrogen or of hydrocarbons. It may also be due to a simple loss of combustible gases and their replacement by oxygen. The extent of the deterioration varies with different coals, but the deterioration is probably most active during the first two or three weeks from the taking of the sample.

AN interesting monograph on the rural highways of Wisconsin, by Mr. W. O. Hotchkiss, has been issued (Bulletin No. 18) by the Wisconsin Geological and Natural History Survey. It covers 136 pages, and is illustrated by sixteen plates. The improvement of the rural highways of the State is a matter to which much attention has been devoted, and the author supplies useful information regarding methods of road construction. He gives a summary of the general principles of making roads, and discusses the conditions obtaining in the State of Wisconsin. In conclusion, he adds a digest of the laws of those States where legislation in the matter of roads has received most careful attention.

IN comparison with the thorough treatment of bridge trusses by eminent writers, very little attention has been devoted to roof trusses, and consequently the exhaustive study described by Dr. N. Clifford Ricker in the University of Illinois Bulletin, No. 16, forms a valuable addition to technical literature. The investigation had for its original object the determination of a formula for the weight of roof trusses more accurate than those in existence. Other

interesting results were incidentally obtained, and the Bulletin gives in detail the results obtained in reference to the formulae for normal wind pressure, the system of calculation and design, the form of stress sheet, the formula for weight of truss; the comparative weights of trusses of various materials, the economical distance between trusses, length of panels and number of purlins per panel, the effect of raising the lower chord at the centre of span (from which no advantage results), and the most economical ratio of rise to span of roof trusses.

We have received parts i. and ii. of the meteorological report of the Survey Department of Egypt for the year 1905. Part i. contains very complete hourly readings and means for each month at Helwan Observatory. Attention is directed to the well-marked daily and annual variations of wind direction and to its prevalence to the east of north, whereas in the Delta it is usually west of north. Part ii. deals with climatological stations, rainfall, and river-gauge observations in Egypt and the Sudan. The annual rainfall was in excess in the Delta and in the Sudan, but deficient in the Cairo district and over middle Egypt. The Nile flood did not reach its mean level at any time during the year.

A DISCUSSION by Prof. J. Schneider of the moon's influence on the wind components at Hamburg is published in vol. xxx. (1907) of *Aus dem Archiv der deutschen Seewarte*. As the work was undertaken principally with the view of ascertaining whether any daily or half-daily influence was exhibited, only the observations for the six winter months, 1887-1896, were used, so that the influence of the sun might be eliminated as much as possible. Among the various results, we note that from the records of the best anemometers the moon's influence is shown to be practically imperceptible in the daily range; the results for anomalistic months show that both components (W.-E. and S.-N.) apparently increase with the approach of the moon to the earth, and decrease as it recedes. The values are tabulated in various ways; for details we must refer to the paper in question.

IN the Bulletin of the Manila Weather Bureau for March, 1907, Father Algué gives an account of a typhoon of extraordinary intensity which visited the Caroline Islands in that month. The storm apparently formed to the south of Ponapé (Eastern Carolines) between March 24 and 26, and moved in a W.N.W. direction to Wlea (Western Carolines), where it arrived on the morning of March 29; by the afternoon of March 30 it reached Mackenzie Island (lat. 10° N., long. 140° E.), when it began to re-curve to the N. and E., passing to the N. of the Ladrone Islands (lat. 20° N., long. 145° E.) on the evening of April 3. In the Wlea group the destruction was almost complete; immense waves carried away houses and everything in their path, and some 200 persons perished on two of the islands. At 7h. 30m. a.m. on March 29 the barometer there read 28.58 inches, and fell rapidly to 27.24 inches at 10h. a.m.; at 4h. p.m. it had risen to 29.10 inches. The wind blew with typhoon force from N.N.E. and N.E. from 3h. a.m. to 10h. a.m., and then shifted to S.E. and S.W., and was still blowing a hurricane from S.S.E. at 8h. p.m. The influence of the storm was not felt in the Philippines, but owing to the vigilance of Father Lopinot, observer at Yap (Western Carolines), who took hourly observations during its passage in that locality, the Manila Observatory was enabled to give timely warning of danger in the Pacific to China and Japan when the cyclone centre was some 1100 miles distant.

FROM Messrs. C. F. Casella and Co., of 11, Rochester Row, Victoria Street, S.W., we have received a set of the "Stonyhurst Sun Discs" which they have recently issued. These discs have been made at the suggestion, and with the assistance, of Father Cortie, and are similar to those used at Stonyhurst College Observatory for a number of years for the determination of the heliographic positions of sun-spots and faculae. Each set includes eight discs, and on each of these is a true orthographic projection of the parallels of latitude and longitude corresponding to the value of the declination of the sun's centre; from 0° to $\pm 7^{\circ}$; for each period of the year. The discs are 6 inches in diameter, and are nicely printed on cardboard, for use with a projected image of the sun, or on transparent glazed linen for use with a drawing of the solar disc. Each set is enclosed in a strong cloth wallet, and may be obtained from the above firm at the price of 10s. 6d. per set.

THE January number of the *Astrophysical Journal* contains a very suggestive article, by Mr. E. Goldstein, of Berlin, on the two-fold line spectra of chemical elements. Mr. Goldstein has found, during a long series of experiments, in which he produced his spectra by employing heavier condenser discharges than have hitherto been employed, that he could replace the well-known spectra of the alkali metals rubidium, caesium, and potassium by an entirely new line spectrum. Previous workers have found some of the new lines appearing with the arc spectra, but have not succeeded in eliminating the latter; in Mr. Goldstein's spectra, however, the new sets of lines appeared alone. As the lines of the ordinary arc spectra fit themselves into series, whilst the new lines fit into no series, it appears that powerful discharges extinguish all the series lines and replace them by non-series lines in the case of the three metals named. In the case of sodium, Mr. Goldstein has not yet succeeded in eliminating the series lines, only in weakening them, whilst in the case of lithium the effect is still less marked. As the density of the discharge necessary to affect the transformation from the series to the non-series, or "fundamental spectra" ("Grundspectra"), lines appears to increase as the atomic weights decrease, it may be that increased experimental facilities will bring sodium and lithium into line with the other three alkalis. Amongst a number of other important suggestions, reference is made to the possibility of the ordinary, or "series," line spectra being emitted by regular groupings of particles which, when subjected to a heavy condenser discharge such as was employed in the present experiments, are broken up, leaving single particles which emit the single uncorrelated lines of the "fundamental spectra."

THE firm of Gustav Fischer (Jena) has published an address on the modern analysis of psychical phenomena delivered by Prof. A. Hoche at the congress of German Naturalists and Physicians held at Dresden last September. Dr. Hoche, who spoke from a point of view that would exclude all quasi-metaphysical discussion from psychology, characterised the present phase of the science as one of "spade-work" carried out by many hands over a wide area, such as commonly recurs after a period of rapid deepening and widening of our conceptions. Progress has presented itself in the form of new demands upon psychology, followed by the appearance of new methods of investigation and the conception of new aims for its efforts. Under the first of these headings fall the applications of psychology to the scientific study of

history and religion, as well as to matters of legal and medical interest. Among the new modes of investigation are the comparative methods, which have to a great extent taken the place of the older introspection; the experimental method, which commands most attention in the present day; and the pathological method, which, taking advantage of nature's own experiments, has thrown much light on the real character of the contents of some parts of our normal experience. Finally, the newer aims of psychology include the attempts to classify actual personalities with reference to standard equilibrated types, and to find a field for practical applications in pedagogy and in the treatment of criminals.

At the suggestion of Prof. A. A. Michelson, Mr. L. E. Gurney, of the University of Chicago, has investigated the viscosity of water at very low rates of shear in order to determine whether any change in its value occurs when the motion of the liquid is slight. The water was enclosed between concentric cylinders, the outer one of which was rotated at a measured rate about its axis, while the inner one was prevented from rotating by means of a couple of measured moment. For rates of shear varying from 5 radians down to 0.66 radian per second the author finds no evidence of an increase of viscosity as large as 1 per cent. (*Physical Review*, January).

In the *Physikalische Zeitschrift* for March 1 Dr. W. Lohmann describes his measurements of the Zeeman effect for the principal lines of helium. The helium tubes were placed in cylindrical holes bored through the pole pieces of the electromagnet in such a way that the electric current through them flowed parallel to the magnetic field. The separation of the outer from the middle lines of the triplets produced was observed by means of an echelon spectro-scope. Dr. Lohmann finds that the separation measured on the scale of reciprocal wave-lengths, i.e. the quantity $d\lambda/\lambda^2$, where $d\lambda$ is the observed change of the wave-length λ , is the same for the whole of the nine lines of helium observed, and is proportional to the strength of the magnetic field used. He considers this result points to an extremely simple form of helium atom.

PROF. AGUSTO RIGHI announces the discovery of a new type of rays in the *Rendiconti dei Lincei* for February 2. It was Plücker who first observed that kathode rays, immersed in a strong magnetic field, trace out the magnetic lines of force. This is now held to mean that the projected electrons really describe high-pitched spirals about the lines of force, which nearly coincide with those lines when the field is very strong. Now Prof. Righi has found that these rays do not, as a rule, convey an electric charge. They are therefore not simple kathode rays. They are more probably sets of molecular magnets, constituted by electrons revolving about positive atoms in the planetary fashion. Such systems would possess considerable stability in a magnetic field of the same sign. They would not, of course, carry an electric charge, being themselves neutral combinations, but less close than ordinary chemical combinations. As the field gets weaker, the orbits would open out, and the system would be retarded, and might even return to the kathode. Prof. Righi has found evidences of such return. He proposes the term "magnetic rays" for the new radiation.

A WORK on "Stone: Quarrying and Preparation for the Market," by Mr. A. Greenwell and Mr. J. V. Elsdon, will shortly be published by the Chichester Press, Furnival Street, London, E.C.

THE thirty-eighth annual report of the Wellington College Natural Science Society has been received. It deals with the society's work during 1907, and serves to show that the activity of the members is well maintained. A complete meteorological report for the year is included in addition to the proceedings of the society.

THE Royal Swedish Academy of Sciences is publishing a new edition of Swedenborg's scientific works in Swedish and the original Latin. The first volume has appeared, and two others are in the press. These three volumes include Swedenborg's contributions to geology, chemistry, physics, mechanics, and cosmology. Introductions are provided to the various volumes, that to the first by Prof. Alfred G. Nathorst, and those to the second and third by Prof. Svante Arrhenius, while those for forthcoming volumes on anatomy and physiology will be by Profs. Gustaf Retzius and S. E. Henschen respectively. The volumes are being edited by Mr. A. H. Stroh, of Philadelphia, and the price of each volume is 8s., payable in advance.

THE general report on the operations of the Survey of India administered under the Government of India during 1905-6 is now available. It has been prepared under the direction of Colonel F. B. Longe, R.E., Surveyor-General of India, and deals with the operations of the department for the survey year ending September 30, 1906. It appears that the total out-turn of detail topographical and forest surveys on all scales was 23,312 square miles, against 26,340 square miles of similar surveys during the previous year, and that no surveys on a smaller scale than 1 inch equal to the mile were carried out during the year. The total area triangulated or traversed for topographical or forest surveys was 27,134, against 19,265 square miles for the previous year. The total area of cadastral and special surveys was 2982 square miles, and the area traversed was 6464 square miles, as compared with 7305 square miles of survey and 6368 square miles of traversing in 1904-5. Among special observations during the year may be mentioned systematic vertical observations of the Himalayan peaks of Kedarnath, Srikanta, Jaunli, Bander Punch, and Nanda Devi from stations near Dehra Dun; if this series of observations can be continued over five or six years the varying effects of refraction and snow-fall will be deducible. Pendulum observations were carried across the plains of the Punjab from Simla to Quetta, and the results have proved that a zone of excessive density crosses the Punjab plains from north to south, underlying Montgomery, Ferozepore, and Mian Mir. The field work of the magnetic survey over different portions of the country has been continued and extended.

OUR ASTRONOMICAL COLUMN.

A POSSIBLY NEW SATELLITE TO JUPITER.—A note in No. 4237 of the *Astronomische Nachrichten* (p. 207, March 6) announces the discovery of a new minor planet, or, possibly, a satellite, near Jupiter. The object was discovered by Mr. P. Melotte on a plate taken by him with the 30-inch equatorial reflector on January 27, and is of the sixteenth magnitude; it has been observed at Greenwich on seven nights since that date, and Prof. Wolf photographed it at Heidelberg on March 3. Should this faint object prove to be a minor planet, its temporary designation will be 1908 CJ, and it will probably prove to be a unique object, as regards its orbit, of its class. But it seems likely—so far as can be judged from the few observations yet made—that it is, really, an eighth member of Jupiter's satellite system, and if this is so it is probably the faintest and most distant yet discovered.

OBSERVATIONS OF JUPITER DURING THE PRESENT OPPOSITION.—M. P. Vincart, of Antwerp, to whom we referred in our issue of January 16 (No. 1994, p. 259) as having made his own reflector, describes his more recent observations of Jupiter in No. 3 of the *Gazette Astronomique* (p. 27). On February 5 the shadow of the fourth satellite, projected on to the bay of the Red Spot, appeared elongated, and was encircled by a brilliant halo where it came in contact with the Red Spot. On February 13, despite prolonged attention, M. Vincart was unable to find the least trace of the regular markings recently described by Mr. Bolton.

M. Vincart states that with his instrument he is able to separate, clearly, the components of γ^2 Andromedæ, whilst with the naked eye he is able to count thirteen stars in the Pleiades and to see Jupiter's third satellite when at its elongations.

RECENT OBSERVATIONS OF VENUS.—The third number of the *Gazette Astronomique* (February 29, p. 21) contains an interesting description, by Mr. J. M. Harg, of Lisburn, Ireland, of his recent observations of Venus, made with refractors of 104 mm. and 123 mm. aperture, and using a magnifying power of 200. Four sets of markings were recognised from time to time during the period December 29 to January 20, and are illustrated by the drawings accompanying the note. The first, in longitude 180° , is a long oblique shadow; the second is in longitude 270° , and is an irregularly shaped marking showing numerous details in its outline; the third is a doubtfully permanent, double marking in longitude 0° ; and the fourth is of a curiously bent form in longitude 90° . Mr. Harg's observations indicate that the rotation period does not exceed 23h. 28m.

THE SYSTEM OF ζ URSÆ MAJORIS (MIZAR).—Prof. Frost, in a brief note communicated to No. 4235 of the *Astronomische Nachrichten* (p. 171, February 29), confirms Dr. Ludendorff's observation of the variable radial velocity of the fainter component of ζ URSÆ MAJORIS, but states that the Yerkes spectrograms show a greater range of velocity, varying from -17 km. to $+10$ km. per second; the period of the variation cannot yet be stated.

The plates of Alcor, the naked-eye companion to Mizar, show that the radial velocity of this star also is variable, the changes in the spectrum being so rapid that it has been found necessary to take spectrograms in continuous succession for several hours; it seems probable that the period will be found to be exceedingly short. A qualitative examination of the spectra obtained shows that the 4481 Mg line and the hydrogen lines are sometimes double, sometimes single. The displacement of the 4481 line with respect to the Ti line of nearly the same wave-length also varies considerably.

MARS AS THE ABODE OF LIFE.—The title of Prof. Lowell's article in the March number of the *Century Magazine* is "The Sun Dominant," and in it the author discusses the analogies between areographical and terrestrial conditions. The evolution of the conditions of habitability on the earth is described, and it is shown that the same kind of evolution is probably taking place on Mars. From the fact that the same species of animals, often the same individuals, are able to sustain life under the vastly different conditions of temperature and atmospheric pressure exhibited at various altitudes in the Andes and similar mountain ranges, it is argued that the variations of temperature and the constant lowness of the pressure on Mars should prove no bar to the possibility of living creatures existing there. The presence of water—demonstrated, since the article was written, by Mr. Slipher's spectrograms—and of vegetation are also discussed, and the article concludes with a discussion of the mode in which the presence of organic life is manifested.

THE VARIABLE STAR β_1 1907, AURIGÆ.—A telegram from Prof. Hartwig, published in No. 4238 of the *Astronomische Nachrichten* (p. 223, March 9), states that the variable star β_1 1907, Aurigæ, which he has found to be of the U-Geminorum type, was of the ninth magnitude on March 6, having increased four magnitudes in one day, whilst within eight days it was less than the fourteenth magnitude.

THE CARNEGIE INSTITUTION.

THE "Year-book" for 1907 of the Carnegie Institution of Washington is now available. It contains the minutes of the last meeting of the board of trustees, the reports of the president, Prof. R. S. Woodward, and the executive committee of the institution, and the reports on investigations and projects. The volume, of 230 pages, serves excellently to indicate the admirable work in science which is being done by means of the grants made by the institution. The subjoined summary of the reports shows the position of the institution and some of the directions in which progress was made during the past year.

At the meeting of the board of trustees in December last a letter from Mr. Andrew Carnegie was read announcing his intention to add 400,000. to the endowment of the institution. The financial statement for the year ending October 31, 1907, shows that the assets of the institution, including real estate and equipments, amounted to nearly two and a quarter millions sterling, the endowment being 2,000,000. At this meeting of trustees the following general appropriations were made for the present year:—publication fund, 10,000.; administration, 10,000.; grants for departments and large projects, 75,988.; and for previously implied grants, new minor grants, and research assistants, 10,000.

The report of the president for the financial year 1906-7 shows that the amounts available during that year were:—for large grants, 109,538.; for minor grants, 15,226.; for research assistants, 5080.; and for publication, 16,400. The aggregate receipts from interest on endowment, interest on deposits in banks, sales of publications, and miscellaneous items, amounted to 578,274.

From the income of the institution during the last six years there has been spent, for large projects, 240,462.; for minor and special projects, 138,530.; and for publication, 28,117. The gross sums allotted to large projects since the organisation of the institution amounted to 271,237., and for minor projects and research assistants to 156,936.

The report of the president also summarises the work of the various departments of the institution. The department of botanical research is engaged on a series of problems the elucidation of which cannot fail to be of the greatest interest and value, whether applied to the restricted field of botany or to the broader domain of biology. By means of observation, experiment, and measurement it is proposed to determine, as nearly as may be, the conditions of development, growth, distribution, migration, and variation of desert plants. Thus, in addition to systematic studies of the forms and distribution of these plants, there must be carried on studies of the factors of temperature, rainfall, evaporation, soil moisture, and anatomical and physiological adaptability. The location of the desert laboratory in a country affording a wide range of plant-forms, as well as a wide range of conditions in altitude, temperature, soil-moisture and soil-composition, presents unequalled opportunities for such studies. Along with these lines of work, the anatomical, physical, and physiological researches of the department staff have already resulted in noteworthy contributions to biological science.

The work of the department of experimental evolution is progressing favourably along lines explained in preceding reports, the principal problems under investigation being those of heredity in plants and animals.

The completion and occupancy of the geophysical laboratory mark a noteworthy advance in the progress of the novel and difficult experimental work carried on in this department of research.

The experiments and investigations of Mr. Luther Burbank in horticulture, and the work of preparing a scientific account of his methods and achievements, are progressing as favourably as the available division of time and labour will permit.

During the season under review, as hitherto, the department of marine biology has extended its laboratory and collecting facilities to specialists in zoological research, eleven such guests having availed themselves of the opportunities afforded at Dry Tortugas and in the adjacent

regions accessible by means of the vessels of the department.

The work of the department of meridian astronomy during the year was mainly devoted to preparations for its larger enterprise of a comprehensive catalogue giving accurate positions of all stars from the brightest to the seventh magnitude, inclusive. Amongst these preparations

strikes at San Francisco the completion of the dome for the telescope may delay its erection until the spring of 1908. The novel tower telescopic apparatus, part of which is above and part below the ground-level, has been substantially completed. This consists essentially of a vertical telescope with a 12-inch objective and 60-foot focal length in combination with a Littrow grating spectrograph of 30 feet focal length, thus furnishing a powerful component in the battery of instruments for direct observations of the sun.

Preparations for grinding, figuring, and testing the 100-inch reflector, the construction of which was rendered possible by the gift of Mr. J. D. Hooker, have likewise gone forward. A fire-proof building for this work has been constructed, and the necessary grinding machine is nearing completion. In the meantime it is expected that the Plate Glass Company of St. Gobain, France, will soon have the large disc for this reflector ready for shipment, since it was successfully cast on August 28 last. In the rough, this disc will weigh about 4.5 tons.

Simultaneously with these varied works of construction, daily photoheliographic and spectroheliographic observations have been made by aid of the Snow telescope. Daily studies of the sun and sun-spot spectra have supplemented these observations, and to them have been added pyrheliometric and solar magnetic measurements, along with numerous laboratory investigations bearing directly on the physical properties of the sun.

The year for the department of terrestrial magnetism has been one of varied activities, and one specially fruitful in the quantity and quality of the results attained. The operations have embraced magnetic surveys of the North Pacific Ocean; surveys on land in Alaska, Bermuda Islands, Canada, Central America, China, Mexico, and South Pacific Islands.

The list of publications issued during the year shows

is a preliminary catalogue, embracing the precise positions for upwards of 6000 stars, which has been brought to substantial completion during the year. This will not only be of great service to the department, but it will be of signal aid also to astronomical science in general. Preparations for the establishment of a temporary observatory in the southern hemisphere are likewise approaching completion. An exhaustive study of the meridian instrument to be used at this observatory has been made, so that its constants and peculiarities may be well known before observations with it are begun.

In conformity with the provision made by the board of trustees at its last meeting for the establishment of a laboratory to be devoted especially to an extension of the physical and chemical investigations in nutrition carried on hitherto under the direction of Profs. Atwater and Benedict, steps were taken early in the year to select a suitable site and to prepare tentative plans for the building. Since experiments on men in an abnormal as well as in a normal condition of nutriment are contemplated, one of the first requirements of a site was proximity to hospitals whence pathological cases may be furnished. It was decided to establish the proposed laboratory in the city of Boston, near the powerhouse of the Harvard Medical School.

The work of the solar observatory is still largely in the preparatory stage and is thus as much a work of engineering as of astronomy. The novelties of construction, equipment, and programme of research for the observatory, along with the initial difficulties presented by the rugged site, conspire to make the undertaking a formidable one.

The principal parts of the 60-inch reflecting telescope have been made ready for mounting, but owing to the labour

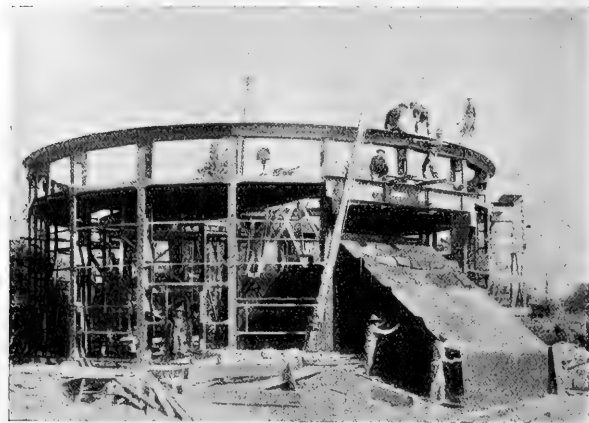

FIG. 1.—Steel Building for 60-inch Reflector, Mount Wilson Solar Observatory.



FIG. 2.—Vertical Celeostat or Tower Telescope, Mount Wilson Solar Observatory.

that thirty-eight volumes were published, with an aggregate of 3428 quarto pages and 6284 octavo pages, respectively. Moreover, there are now in the press twenty-three volumes. The total cost of completed publications issued during the five years ending with that under review reaches 33,807. As regards the general aspects of this subject, there are indications of over-production in the line

of scientific publications. The world appears to be accumulating knowledge faster than it can be assimilated. Even by aid of the comprehensive bibliographies now issued, it is difficult, if not impossible, for the specialist to become conversant with the current literature of his own field. On the other hand, the standard of excellence in publications is undoubtedly higher now than at any previous epoch, although it may not have kept pace adequately with the increasing productivity of our times.

SOME LONDON PROBLEMS.

LONDON'S TRAFFIC.

THE deputation a short time ago from Browning Hall to the London County Council, and the numerous references which have been made in Parliament and elsewhere to the question, make it appear likely that before very long steps will be taken by the Government to establish a Traffic Board for London. In fact, the President of the Board of Trade has given us to understand that his department is in favour of it, and that he will endeavour to get the matter settled without delay; for the new Traffic Department of the Board of Trade cannot be anything but a temporary step.

Among the mass of valuable information collected by the last Royal Commission not the least interesting was that dealing with the history of this problem, for the London traffic problem is almost as old as the city itself. From the earliest days London has suffered from the congestion of its narrow streets, arising from the accumulation of traffic and the encroachments of buildings, and just as at the present day so in previous centuries every attempt made to widen individual streets or to provide increased facilities led to such an increase of traffic in that particular avenue as to render the final state of congestion worse than before. Nothing is more characteristic of the traffic problem than this phenomenon, that every increase of facilities produces an increase of traffic, and so on.

Spasmodic attempts had been made by the corporation of London and other bodies to widen streets here and there, and during the earlier part of the seventeenth century several proposals were brought forward, but were shelved owing to the state of politics at the time.

After the Restoration, however, and just before the Great Fire, an Act was passed for repairing and enlarging the streets with the express object of improving traffic, stating that many streets were too narrow for vehicles. It is interesting to note, however, that increased traffic was anticipated, and the Act also provided for the regulation and licensing of hackney carriages; but immediately after came the plague and the fire, after which a new Act was passed. This was London's great opportunity, and both Sir Christopher Wren and John Evelyn brought forward comprehensive schemes for rebuilding. Had either of these been followed, untold millions would have been subsequently saved to London. It would to-day have been one of the most orderly and carefully laid out cities, with great avenues radiating from the centre. Had this taken place the subsequent growth of the suburbs would have naturally followed on the same plan, and the present heterogeneous arrangements of suburban streets would have never grown up.

In the eighteenth century the conditions were very analogous to those of the nineteenth. If we suppose mail coaches for railways, riding-horses for bicycles, hackney carriages for cabs and motors, we see that London was even then provided with a considerable variety of means of transport.

The first Parliamentary Committee upon metropolitan traffic met in 1830, the matter being brought into prominence by the imminence of railways being built in the London district. Other committees succeeded, and in 1842 a Royal Commission was appointed under the Earl of Lincoln, the Commissioner of Woods and Forests, as chairman; various improvements were therein suggested, but it was not until 1853 that Parliament gave a definite start to the modern idea of London local government.

In 1845 the need of improved means of locomotion were realised, and no fewer than nineteen Bills were promoted in that year dealing with railways in the metropolitan district, at least one of them containing the suggestions for a metropolitan central station.

Not until 1854, however, did the first underground line from Paddington to Farringdon Street receive Parliamentary sanction. It was opened in 1863, and was followed by the construction of a similar line from Victoria to Kensington in 1868, but the inner circle was not completed until 1884.

LONDON'S PORT.

The chief difficulty under which London suffers in connection with its port, as in connection with so many other matters, arises from its age. It is so much older than its rival ports that steps which are taken by them so as to keep them up to date are rendered far more difficult in the case of London. Nothing is easier than to point to Rotterdam or Liverpool as examples of what might be done, but those who do so too often forget the fact that the Port of London has a history of 500 years, compared with less than a century of serious trading in those other ports. The Port of London question is a good, nay, one of the best, examples of the truth that "circumstances alter cases."

The result is that there are an inordinate number of authorities concerned in dealing with the question, and an inordinate number of vested interests to be considered. Moreover, the conditions of transport have changed very materially. In the Middle Ages London was the *entrepôt* for the whole of western Europe. The East Indian unloads there, and their cargoes were distributed by smaller vessels over the whole of western Europe. At the beginning of the nineteenth century, however, trade began to go to other ports. The rise of Liverpool, Glasgow, Hamburg, Antwerp, &c., means that the population surrounding those ports are now no longer supplied from London. Nevertheless, the great increase of population in London itself and all England as a whole, maintains the actual amount of traffic coming into London at its former figure, and London acts as a distributing centre for 10,000,000 to 12,000,000 persons.

The control of the Thames is in the hands of the Thames Conservancy, the dock companies, the Trinity House, the Corporation of the City of London, and the County Council, while the wharfingers and lightermen also have most important interests.

In Liverpool, on the other hand, or in Glasgow, the Harbour Trust has practically a monopoly of authority, and this enables a policy to be adopted which is far less trammelled by outside interference.

Certain of the docks in London are so old that it is impossible to think of modernising them in any way, but the India Docks could undoubtedly be very much improved, while the Tilbury Docks are said to be capable of docking nearly any ship at present afloat. The problem of docking, however, is one that has to be constantly altering on account of the growth of steamships. Hence docks, if they be large enough to-day, would, in a few years' time, be too small, and any docks which are now constructed; in order to have something in hand, need to be of the order of 1000 feet in length. It is not, however, in length that the docks are so much lacking in London, but in the depth of the sills, which render it impossible for vessels of more than 30 feet to enter, for the Royal Albert Dock can take ships up to 536 feet long.

New York and Boston are arranging for 40-foot channels into their ports and steamers are to-day leaving Baltimore loaded down to 32 feet, whereas, at the present time, a ship drawing only 28 feet may be delayed for five hours in the Thames on any day.

What is really wanted is a channel at least 30 feet deep at low tide and 1000 feet wide, as far as the Albert Dock gates, and 1000 feet is not at all too wide to allow a 750-foot vessel to be turned.

Numbers of schemes are constantly being brought out dealing with the port, such as the Thames Barrage Scheme of last year, in which the whole river was to be docked

from Gravesend upward, providing for deep-water quays. Less ambitious proposals are the docking of the River Lea and the provision of jetties at Canvey Island, and minor alterations of the docks. All these are, however, matters which should be dealt with by the Trust if one be appointed.

LONDON'S ATMOSPHERE.

Several causes have recently combined to direct attention to the question of London's atmosphere. The memorandum issued last year by the First Commissioner of Works relating to the damage done to vegetation in the parks, the recent report by the L.C.C. upon the regulation of the smoke nuisance, and the invention of several smokeless fuels, have alike brought home to the public the fact that we have as yet only touched the outskirts of the problem of smoke nuisance. Useful as the various palliatives suggested may prove, consideration of them must always ultimately lead to the fundamental question, Why should any fuel be burned in London at all?

From its position in the Thames Valley, London will probably always be subject to white fogs, and the presence of six million human beings and numerous animals must always be the cause of great pollution of the atmosphere. There is all the more reason, therefore, for seeking some way of reducing or removing the present consumption, within the metropolitan area, of nearly fifteen million tons of fuel annually. Regulations and the use of smokeless fuels would undoubtedly be a move in the right direction, and might to some extent reduce the amount of the visible products of combustion. They would, however, hardly affect that equally important side of the problem, the production of carbonic and sulphurous acids. To do this to any considerable extent means the ultimate abolition of the consumption of fuel in the metropolitan area. Utopian as such a step may appear at the present time, the evidence tendered before Parliament during the past few years in connection with the proposed supply of electric power shows that the establishment of a large central system would have undoubtedly tended in this direction.

This result involves two steps:—

First, the reduction, by the adoption of improved methods, of the total quantity of coal burned to produce the power required in the metropolitan area; and, secondly, the removal of the place of combustion to the metropolitan limits.¹

These two results can only be secured by the general substitution of electric power for other forms.

Let us now consider to what extent it is to-day practicable for electricity to replace the direct combustion of coal in various industries.

Owing to the high price of electricity, the use of gas for street lighting is in many cases still quite as cheap as the electric light, while there are still many parts of London where power derived from gas engines is even cheaper than the supply of electric power at present available; but the abolition of gas for lighting the streets and for driving gas engines will certainly follow its abandonment for lighting purposes in good private houses, if only the price of electricity be reduced sufficiently low. The flame arc lamp, containing as it does the necessary rays for piercing a fog, removes the objections which apply both to ordinary arc lamps and to incandescent mantles, and is the most suitable system of lighting for important streets which one could have. If electricity were available in London at a maximum price of $\frac{3}{4}$ d. a unit for street lighting, there would be a great saving effected over every other system of lighting now in use. At the present time, however, interior electric lighting is chiefly used in the West End and in large shops and offices where the price is a secondary consideration, while public lighting is only done widely where the municipality itself provides the current. It cannot be said to have penetrated

¹ So far as gas consumption goes this question of removal has partly taken place already. In place of the seventeen or eighteen gas companies with works scattered throughout London which are shown on the old Ordnance maps, there are now practically three authorities, and by far the larger part of the coal consumption to make gas for London is used on the Greenwich Marshes at Peckham.

the poorer quarters in the way that gas has done by means of penny-in-the-slot meters, which it was recently stated bring in to the Gas Light and Coke Company 1,000,000. per annum; but at $1\frac{1}{2}$ d. to 2d. per unit, electric light would certainly be cheaper than any gas which is being sold in the metropolitan area to-day.

The adoption of electricity for suburban traffic is long past the experimental stage, and provided power can be obtained sufficiently cheaply, there is nothing to prevent all the railways in London being driven electrically. The experience already obtained on the North-Eastern Railway, where the heavy suburban traffic is handled electrically, or at Liverpool or on the Underground Railway, has shown this. That the haulage of main-line trains by electricity in suburban areas is also feasible is proved by the fact that the two most important railway companies in New York—the Pennsylvania and the New York Central Companies—have arranged to haul the whole of their main-line trains by electric locomotives while in the suburban districts.

Nearly half the cost of operating suburban services by electricity is due to the cost of the power, while in many cases the capital outlay on the generating station forms half the total cost of the electrification. Thus the price of electricity and the difference in capital outlay between the erection of independent stations or its avoidance may make all the difference between it being commercially feasible to electrify or not; but at the present time there is no means by which the railway companies of London can get a suitable supply except by putting up stations for themselves. The supplies which are at present in existence are on too small a scale, and were primarily intended for lighting purposes. Moreover, as the law stands, the majority of the electric lighting authorities can only supply for use in their own areas, so that the railway companies would be obliged to purchase their supplies piecemeal along their routes. As there are twenty-one different systems in London, the impracticability of this, for this reason alone, is obvious. The cost of electrification under these conditions would, of course, be out of the question. In order to be really satisfactory the price of power should be of the order of $\frac{3}{4}$ d. per unit. On the Tyne, the North-Eastern Railway Company pays rather more than this, but in London the higher cost of coal would be far more counterbalanced by the enormous output. The average consumption of locomotives at the present time is 4 lb. to 5 lb. per horse-power, as against 2 lb. per horse-power in a central generating station. It has been estimated that the total horse-power required for operating the present suburban line traffic in the London district would be 120,000, while the suburban traffic on main lines would take another 30,000, and that an annual production in all of some 600,000,000 Board of Trade units would be needed. As a matter of fact, a larger output would probably be required, because one of the chief objects of electrification is to enable a more frequent service to be run; but as the total output of the London electric lighting stations last year was of the order of 150,000,000 units, it is obvious that one cannot look to them for a supply for this purpose even if they were all united into one station and supplying on one system, instead of supplying from more than fifty stations with more than twenty systems. It is a question of price, and the price is one the existing systems cannot supply at.

Coming now to the factories, it will be noted that these account for nearly one-half of the coal consumption of London, and probably for three-quarters of the smoke and deleterious fumes; yet these offer the best field for electric power of any, for the possibility of driving factories electrically has been conclusively demonstrated on the Tyne, where, practically speaking, every factory and shipyard on the north bank of the river obtains its supply from the power company which is there in operation. Power is applied to all kinds of purposes. The three-phase electric motors, which contain no exposed electrical parts, work without trouble in the most exposed conditions.

Cranes, both stationary and travelling, are more conveniently operated by electric motors than by the old vertical boilers and engines. In fact, there are practically

no uses to which the electric motor does not lend itself in factories.

The objection which is often raised, however, to the replacing of steam-driven machinery by electricity, especially in chemical works, breweries, soap works, &c., is that the steam is required for heating and boiling; but here, again, it is a question of price only; the chief chemist of one of the most important soap makers in the east of London recently stated that it was purely a question of price for him to use electricity for boiling purposes instead of steam, and he estimated that it would pay him to do this if he could obtain it at not more than $\frac{3}{4}d.$ per unit.

Now a certain number of London factories are already supplied from the existing lighting stations. So great are the benefits of electricity that it has paid people to adopt it even although electric energy is so expensive, for so long as electricity is provided from electric lighting stations as an adjunct, so long must it necessarily be expensive; but the wholesale adoption of electricity in factories on the scale that it has taken place on Tyneside can only take place when electricity is produced on an enormous scale, and is used for all purposes in the district. Hitherto, power has been supplied as a by-product of electric lighting, and this accounts for the fact that out of 555,000 horse-power required to drive the factories in the industrial districts of London, only some 26,000 or 27,000 horse-power of electric power is obtained from the present stations.

This great field that remains can only be tapped by putting down a system for the express purpose of supplying the power needs of East London; while such a scheme must, in order to produce cheaply, have as great a variety of consumers as possible, it cannot hope to be completely successful if it is made an adjunct of electric lighting or electric traction. Power supply must be the first aim of the undertaking, even although in the process of getting a power supply an even greater load may be obtained from the supply to railways.

The consumption of coal in domestic fires accounts for 4,570,000 tons a year, or 25 per cent. of the total consumption. Electric heating has hitherto been very little used, and even in America is confined to the heating of tramcars and workshops in places where it is only a question of the cost of electric energy is undoubted, and that electricity forms a most convenient agent in heating and cooking, and can replace all other forms, is now generally admitted. The reason is this, that whereas the ordinary gas fire only, as a rule, gives out from one-half to one-third of its heat usefully, while the best stove probably does not give out more than about 75 per cent. of its heat, the efficiency of the electric radiator is practically 100 per cent. It can be shown that if the cost of electricity be 15. $3d.$, it is as cheap for cooking as gas at 3s. per 1000 feet; but to compete with coal at 25s. a ton for heating, electricity must be supplied about $\frac{3}{4}d.$ per unit. In a number of houses already electric radiators are being adopted on account of their convenience, even though they cost somewhat more than gas fires; with cheap electricity they would be adopted universally.

Thus, although electricity for heating and cooking has been looked upon as a purely Utopian proposal, as a matter of fact the time is not far distant when it will be found quite as cheap as any other form of heating. It is true that an electric radiator in its present form, although efficient in itself, converts but a very small portion of the energy of the coal into heat; but this is, of course, due to the inefficiency of the present methods of producing electricity, and there can be little doubt that we shall before very long witness a very considerable improvement in this respect. Whereas the best modern turbines and boilers convert only 15 per cent. of the energy of the coal into electricity, the internal combustion engine converts 35 per cent.; but even at the present time such are the advantages of electricity for heating and cooking, such is its applicability, such is the cost of re-decorating and cleansing in London, that at prices considerably higher than those above stated electricity would be as cheap to adopt as coal or gas. The question again resolves itself into one of price.

UNIVERSITY AND EDUCATIONAL INTELLIGENCE.

CAMBRIDGE.—The Goldsmiths' Company has resolved to make a grant of 10,000*l.* for the purpose of founding and endowing a readership in metallurgy, such readership to be associated with the name of the company. It is hoped that research and other work in the precious metals, and the theory and practice of assaying, will be kept somewhat prominently in view in connection with the proposed readership.

Mr. R. H. Biffen has been elected to the recently established chair of agricultural botany. Mr. Biffen is the author of numerous papers, the earlier of which dealt with the preparation of india-rubber and the coagulation of latex, and he has devoted a great deal of attention to fungi. His researches on the hybridisation of wheat and barley have attracted the attention of civilised Governments throughout the world, and attempts have been made to induce him to leave England and place his services at the disposal of at least one foreign Government. It is satisfactory that largely owing to the generosity of the Drapers' Company Mr. Biffen will be able to continue to carry on his researches in Cambridge.

Mr. C. L. Boulenger has been appointed assistant to the superintendent of the museum of zoology from March 25 to September 30, 1908.

ON Friday evening, March 13, Lord Alverstone distributed the certificates and prizes at the South-Western Polytechnic Institute, Chelsea. The report of the principal to the governing body showed that the session 1906-7 had been a very successful one, the highest honour obtained being the D.Sc. degree of Mr. Crocker, who had done all the necessary chemical research in the institute. In the course of a short address, Lord Alverstone laid great stress on the necessity for concentration in study. The development of any one subject is so great at the present time that the utmost concentration of thought is required to advance knowledge. He took as illustration the discoveries of Lord Kelvin in regard to the mariner's compass.

The reports for the year ending June 30, 1907, of the librarian of the U.S. Congress and of the superintendent of the library building and grounds have been received from Washington. As indicative of the generous scale on which this great American library is subsidised, it may be stated that the appropriations made for the present year reach 123,000*l.*, and that the salaries to be paid during the year for the various officers reach 69,570*l.* In 1907 the number of books in the library reached 1,433,848, representing a gain of 54,604 over the previous year. In addition there were nearly 100,000 maps and charts and a quarter of a million prints. The most important accessions to the library were the Yudin library, consisting of 80,000 works relating to Siberia and Russia, and a notable collection of the literature of Japan, consisting of some 9000 works.

A BILL to promote agricultural education and nature-study in public elementary schools, introduced in the House of Commons by Mr. Jesse Collings, was read a second time on March 11. The object of the Bill is to provide for the teaching in all public elementary schools of agricultural and horticultural subjects; to give facilities for nature-study, and generally by means of object-lessons to cultivate habits of observation and inquiry on the part of the pupils. To this end the Bill provides for school gardens and such collection of objects as may be necessary for the practical illustration of the instruction given. The education specified in the Bill, while optional in urban schools, is to be compulsory in all schools situate in rural and semi-rural districts. A special grant, not exceeding 75 per cent. of the cost, is provided for in the Bill towards the expenses of local education authorities in carrying out the provisions of the Bill.

In his capacity of Chancellor of the Bombay University, Sir George Clarke presided at the recent annual Convocation of the University and delivered an address. From a report of his speech in the *Pioneer Mail* we learn that

the Chancellor directed attention to the fact that at present there is in the University no provision for post-graduate training, which, in Japan, can be carried on for five years. The University at present receives immature students, and has been unable to utilise the best of its teaching powers and to train up to the high standard now required to produce leaders of original research and professors in the great departments of knowledge. The institute which the munificence of the late Mr. Tata is providing will afford facilities for post-graduate courses in science, and Sir George Clarke expressed the hope that the University will be able to move in this direction in the future. India, he continued, is crying aloud for science, but in the last years only twenty-five degrees of Bachelor of Science were conferred as compared with 1321 Bachelorships of Arts. The Bombay system is defective in regard to scientific training. The inculcation of scientific ideas does not begin early enough, and cannot be carried far enough, for want of adequately equipped laboratories. In Japan science is taught in the upper primary courses, but does not appear until a much later stage in Bombay, and may almost be said to be confined to the colleges, which cannot all be equipped with the expensive appliances necessary for the training they ought to be able to impart. The attempt to make each college into a complete teaching university must, the Chancellor said, necessarily fail, and concentration, in the case of science training especially, appears to be essential. A beneficent patron of learning could render no better aid to the advancement of science than by providing the University with first-class physical and chemical laboratories. Principal Sharp has pointed out that expenditure on education in India would have to be increased from about four millions sterling to twenty-seven millions to provide an amount per head equal to that available in Japan.

SOCIETIES AND ACADEMIES.

LONDON.

Royal Society, February 20.—"Notes on the Application of Low Temperatures to some Chemical Problems: (1) Use of Charcoal in Vapour Density Determinations; (2) Rotatory Power of Organic Substances." By Sir James Dewar and Dr. H. O. Jones.

(1) In a recent paper (*Phil. Mag.*, 1907, vi., 14, 408) Barkla and Sadler describe the investigation of the penetrating power of secondary Röntgen radiations emitted by different elements, which they find to be dependent on the atomic weight of the elements. The behaviour of nickel could only be reconciled with that of other elements by assigning to it an atomic weight of 61.4, a value considerably higher than the accepted value, 58.7.

Determinations of the vapour density of nickel carbonyl made by the authors (*Proc. Roy. Soc.*, 1903, lxxi., 427) had given no indication that the accepted value for the atomic weight of nickel was too low, but it was considered of interest to make further determinations at low pressures, when the vapour would approximately obey the gas laws.

A new method of manipulation was devised for this purpose depending on the use of charcoal at low temperatures for absorbing gases.

A large flask, the volume of which with the connecting tubes was 2163.2 c.c., was connected to a mercury manometer and exhausted by means of a Fleuss pump followed by charcoal in liquid air. The flask was surrounded by melting ice, and the vapour admitted to any desired pressure. The mass of gas was finally collected in a weighed charcoal reservoir by immersing this in liquid air. Thus the weight of vapour filling the flask at 0° C. under a known pressure was easily determined. The accuracy of the method is dependent on the determination of pressure, since the errors in the other operations are comparatively negligible.

In order to test the method the vapour densities of carbon dioxide, sulphur dioxide, and ether were determined, and the following results (referred to 1 c.c. of hydrogen as 0.0009 gram) show that the method readily

gives results sufficiently accurate for the purpose in hand:—

CO ₂			SO ₂			Ether		
Press. mm.	V.D.		Press. mm.	V.D.		Press. mm.	V.D.	
115.4	21.91	...	76.1	31.81	...	31.4	...	36.90
200.5	21.98	...	198.5	31.94	...	63.9	...	36.91

The theoretical values of these vapour densities are 21.83, 31.79, and 36.76 respectively.

Determinations of the vapour density of nickel carbonyl were then made, with the following results:—

Press. mm.	V.D.	Press. mm.	V.D.	Press. mm.	V.D.		
16.6	84.67	...	41.7	84.69	...	46.8	84.79

Taking the atomic weight of nickel as 58.3 (H=1), the theoretical density is 84.73, whereas on the assumption of the atomic weight suggested by Barkla and Sadler, 60.95 (H=1), the vapour density would be 86.05. These experiments therefore show that it is impossible that the atomic weight of nickel should be as high as 60.95.

The accuracy of the method used could be greatly improved by the use of a larger vessel and more delicate manometric measurement, and if the charcoal condenser was made of metal instead of glass the method might be applied to the more volatile gases.

(2) A preliminary account is given of the results obtained in determining the rotatory power of optically active carbon compounds at low temperatures. Two substances, l-nicotine and "bitter orange oil" were selected as suitable for examination, because their solutions in ethyl alcohol could be solidified without losing their transparency, and on account of their high rotatory powers. Up to the present it has only been found possible to make observations down to about -100° C., since below this double refraction interferes with the reading of the polarimeter.

A solution of nicotine (21.2 grams in 100 c.c.) which gave a rotation of -30° at +20° C. gave a rotation of -22° at -120° C.

The relation between temperature and rotatory power is approximately linear, and shows that nicotine behaves below 0° C. just as it does above that temperature. The specific rotatory power at -115° C. is calculated to be -99°, and, assuming the linear relation to hold, would be about -54° at -273° C.

The rotatory power of bitter orange oil increases with diminishing temperature below 0° C. as it does above that temperature.

A 20 per cent. solution in alcohol, which gave a rotation of +18.5 at +8° C., gave a rotation of +25.5 at -95° C. The relation between temperature and rotatory power is linear, and the calculated specific rotatory power at -273° C. would be about +156°.

Similar results have been obtained with other substances, and these show that the molecules of optically active carbon compounds would exhibit in all probability considerable rotatory power at the lowest temperatures we can command.

Linnean Society, February 20.—Lieut.-Col. Prain, F.R.S., vice-president, in the chair.—Wild types and species of the tuber-bearing Solanums: A. W. Sutton. Many hundreds of attempts were made to fertilise *Solanum Maglia* with the cultivated potato, but only one hybrid seedling resulted, from a cross made in July, 1887, and though cultivated for twenty years it has shown no superiority to ordinary potatoes. The so-called "*Solanum Commersonii*, Violet," was stated to be a mutation obtained through bud variation from the wild *Solanum Commersonii*, Dunal. In opposition to this claim, many growers assert that it is identical with a German potato, the "Blue Giant," raised by Herr Paulsen. Many wild types of tuber-bearing Solanums have been experimented with during the last few years. All these wild types flower freely, but in every case where a wild type produces fruit it has, with the exception of *Solanum tuberosum*, reproduced itself absolutely pure from seed, whereas all varieties of the cultivated potato which produce seed give rise to the greatest possible variation in the seedlings, none corresponding exactly to the parent. There is also a striking difference in the form of the pollen-grains of the wild types of tuber-bearing Solanums com-

pared with pollen-grains of cultivated potatoes, the former being elliptical and the latter very irregular in form. *Solanum tuberosum* is the only wild type of which the seedlings have not reproduced the typical form, but have, on the other hand, given precisely the same variation in habit of foliage, form, size, and colour of tuber, &c., as is found in the seedlings from the cultivated potato. During the twenty years of cultivation, no plant of *Solanum tuberosum* has ever been noticed as affected by the fungus *Phytophthora infestans*, although during the whole period it has been grown in close association with potatoes which have suffered more or less from it year after year. It is a fact that the potatoes originally introduced into England or into Europe were certainly introduced as cultivated potatoes, and not as wild types, and also that it is at least doubtful whether in Chili, Peru, or elsewhere, any specific type of tuber-bearing *Solanum* (apart from *Solanum tuberosum*) can be found which will, under cultivation, give plants at all like the potato of commerce.—Life-histories and larval habits of the tiger-beetles (Cicindelidae): Dr. V. E. Shelford. The paper is intended to be followed by a series in which the distribution, variation, effects of environment, and evolution of colour will be considered. Eleven races were studied, and the results detailed from three or four thousand individuals which had been reared to maturity; the detailed account of *Cicindela purpurea* is followed by a comparison of the other races, and the paper concludes with a bibliography.

March 5.—Lieut.-Col. Prain, F.R.S., vice-president, in the chair.—A possible case of mimicry in the common sole: Dr. A. T. Masterman. There are two species of weaver-fish, *Trachinus draco* and *T. vipera*, both venomous, with the poison concentrated at the spines of the first dorsal fin and the opercular spine. These fishes bury themselves in the sand until only the top of its head, with eyes, mouth, and dorsal fins are above the sand. The dorsal fin is of intense black, and conspicuous amongst the sand when protruded; it has been suggested that this may be regarded as a warning signal to the enemies of these fishes. The right or upper pectoral fin of the common sole (*Solea vulgaris*) is well developed, and the upper half of that fin has a large, deep, black patch. It also has the habit of concealing itself under the sand, and the distribution of the weaver-fishes and the common sole is almost the same. In the other species of sole the pectoral fin is smaller, or almost wholly wanting. The suggestion is that the common sole has adopted the habit and coloration of the weaver-fishes as a protective measure.—The morphology of Stigmara and of its appendages in comparison with recent Lycopodiales: Prof. F. E. Weiss. The discovery by Binney of an organic connection between Stigmara and the base of Sigillaria did not settle definitely the morphological value of the stigmara axis. It might still be regarded either as a large bifurcating root bearing lateral roots or as an underground stem (rhizome), in which case its appendages might be adventitious roots (Scott) or leaves modified to serve absorptive purposes (Solms-Laubach), or possibly both kinds of lateral organs might be present (Renault). Some recent observations have tended to re-open the discussion of the morphology of the appendages, particularly the recognition of peripheral "transfusion" tracheids in the stigmara appendages and the presence of a parichnos-strand in these organs. But though both have their counterpart in the leaves of the Lepidodendraceae, the author only sees analogy and not homology in these structures, and believes their presence is due to the physiological requirements of the organs in question. On the whole, it seems likely that these problematical organs are lateral extensions of the protocorm of a primitive member of the Lycopodiales.

Physical Society, February 28.—Dr. C. Chree, F.R.S., president, in the chair.—The contact potential differences determined by means of null solutions: S. W. J. Smith and H. Moss. When a mercury jet breaks in the surface of an electrolyte there is an E.M.F. between the jet and a still immersed mercury electrode. If the contact p.d. between the still mercury and the solution is π_s , that between the jet and the solution being π_d , the observed E.M.F. is $E_p = \pi_s - \pi_d$. This E.M.F. is found to be equal to the polarising E.M.F., E_{p1} , required to produce the maximum surface-tension between mercury and the electro-

lyte. Since $E_m = \pi_s - \pi_m$, where π_m is the p.d. between the Hg and the electrolyte when the surface-tension is a maximum, it follows that $\pi_m = \pi_d$. A solution for which $E_p = 0$ is called by Palmaer a "null solution." He found by trial two solutions for which $E_p = 0$. Although he concluded that $\pi_s = \pi_d = 0$, without special assumptions, the only necessary conclusion is $\pi_s = \pi_d = \pi_m$. The object of this paper is to show that Palmaer's deduction is wrong. If an experimental method can be found of obtaining from any electrolyte MX a solution for which $E_p = 0$, then an indefinite number of null solutions can be obtained. Such a method consists in the addition to the electrolyte of a small quantity of M₂S. A number of null solutions were found, including one which gave results identical with those obtained by Palmaer.—An experimental examination of Gibbs's theory of surface concentration regarded as the basis of adsorption, and its application to the theory of dyeing: W. C. M. Lewis. An experimental investigation of Gibbs's theory of surface concentration. A particular form of the more general equation is

$$\Gamma = \frac{-c}{RT} \frac{d\sigma}{da_2}$$

where Γ = the excess mass of solute per sq. cm. surface, c = the bulk concentration of the solution, T = the absolute temperature, R = the gas constant, and σ = the surface-tension. Assuming surface-tension effects to be the basis of adsorption, measurements were made of the quantities above. The material at the surface of which adsorption took place consisted of a pure hydrocarbon oil. The material adsorbed was bile-salt in aqueous solution. The interfacial tension σ was measured by the drop-pipette method. Γ was measured in two ways:—(1) at the surface of oil-drops of radius about 1 mm., and (2) at the surface of drops of radius about 10^{-4} mm., i.e. emulsion particles. The general result was that the actual values found for Γ exceeded the calculated by about fifty times the latter, the conclusion being that there is a discrepancy of considerable magnitude.

Zoological Society, March 3.—Mr. G. A. Boulenger, F.R.S., vice-president, in the chair.—A young female Kordofan giraffe: P. C. Mitchell. The author compared the coloration of this specimen, born at the gardens, with that of its parents and with that of a young female giraffe from Nigeria, now living in the society's collection, and stated that the evidence to be derived from the study of this specimen strengthened the case for the distinctness of the giraffes from Kordofan and Nigeria.—A comparison of the neotropical species of *Corallus*, *C. cookii* with *C. madagascariensis*, and on some points in the anatomy of *Corallus caninus*: F. E. Beddard.—A new species of the monkey of the genus *Cercopithecus*: R. I. Pocock. The species differs from *C. neglectus* principally in the absence of the black band across the head, in the reddish tinge of the hairs beneath the callosities, and in the similarity in colouring between the tail and the body. It is proposed to name this new monkey *Cercopithecus ezrae*.

Entomological Society, March 4.—Mr. C. O. Waterhouse, president, in the chair.—Exhibits.—F. B. Jennings: (a) A specimen of the weevil *Phyllobius maculicornis*, Germ., retaining both the "false" mandibles, and another in which one of them is intact, both from Enfield, also a single example of *P. urticae*, De G., from Cheshunt, retaining one of these mandibles, the particular point of interest in connection with the false mandibles in these species being that they are toothed in the centre; (b) a remarkable specimen of the common Chrysomelid beetle, *Sermyla talensis*, L., from Deal, showing unusual coloration of the elytra, which are blue and coppery-red instead of bright green; and (c), on behalf of Mr. C. J. Pool, a specimen of *Otiorrhynchus tenebricosus*, Herbst., from Newport, I.W., and of *Barynotus obscurus*, F., from Galway, Ireland, in the first of which both the pupal mandibles were toothed, and in the second not.—H. St. J. Donisthorpe: *Otiorrhynchus sulcatus*, *Polydorus sericeus*, and *Osmius bohemanii* with pupal mandibles. The *Otiorrhynchus* was dug up in its pupal cell at Oakham in 1895.—The Rev. G. Wheeler: A case containing specimens of Melitrid butterfly taken by him at Rezzano in Tessin, near Bellinzona, which he had identified with

Assmann's *Melitaea arelia*, var. *britomartis*, they being absolutely identical with the specimens so labelled in the Swiss national collections at Berne. The close affinity on the underside with *M. dictynna* made separation superficially very difficult, and until all forms were reared from the ovum it would be impossible to determine whether *britomartis* constituted a separate species or not.—*Papers*.—Descriptions of new species of Lepidoptera-Heterocera from the south-east of Brazil: H. D. Jones.—*Erebria lefebvrei* and *Lycaneta pyrenaica*: Dr. T. A. Chapman.—A contribution to the classification of the coleopterous family Dynastidae: G. J. Arrow.—Hymenoptera-Aculeata collected in Algeria by the Rev. A. E. Eaton and the Rev. F. D. Moricre, part iii., Anthophila: E. Saunders.

Royal Meteorological Society, March 11.—Dr. H. R. Mill, president, in the chair.—The dawn of meteorology: Dr. G. Hellmann. Some of the modern weather proverbs can be traced back to Indo-Germanic and Babylonian sources. Some of the tablets excavated from old Babylon contain references to the weather. Speaking of the names of the winds and their combinations, Dr. Hellmann said that the cardinal points, north, east, south, west, were found in old Babylonian times. The Greeks were the first to make meteorological observations, and had parapemata or weather almanacks fixed on public columns. The measurement of rain was first recorded in Palestine. After referring to the first idea of the thermoscope, the lecturer alluded to the meteorology of Aristotle, and said that it had very little influence on English meteorologists. It was the fathers of the Church who kept meteorology alive, for in their works on the Creation they devoted much attention to the atmosphere. The writings of the Venerable Bede were also referred to. The resuscitation of experimental science in the thirteenth century led to the development of regular meteorological observations in the fourteenth century. The earliest known record in this country was kept by the Rev. William Merle at Oxford from January, 1337, to January, 1344, the manuscript of which is still in the Bodleian library.

Mathematical Society, March 12.—Prof. W. Burnside, president, in the chair.—The projective geometry of some covariants of a binary quintic: Prof. E. B. Elliott. The roots of the quintic being represented by points on a conic, ruler constructions, depending only on symmetric functions of the roots, and not on the roots individually, are given for those linear covariants which are of degrees 5 and 7 in the coefficients, and for the quadratic covariant which is of degree 2 in the coefficients. Constructions are also obtained for the linear covariants of degrees 11 and 13 in cases where the roots of the quintic are known individually. It appears that sets of four linear covariants and three quadratic covariants can be arranged as a quadrangle on a conic and the pairs of points in which the conic is met by the sides of the harmonic triangle of the quadrangle, but that two members of such sets of seven covariants are reducible to simpler members of a complete system.—The inequalities connecting the double and repeated upper and lower integrals of a function of two variables: Dr. W. H. Young. Difficulties arise in the theory of integration of a function which may become infinite, especially as to the possibility of replacing a double integral of such a function by a repeated integral. The paper contains a systematic investigation of such cases, and conditions are obtained which are sufficient to secure that the double integral can be evaluated as a repeated integral.—The operational expression of Taylor's theorem: Dr. W. F. Sheppard. Cases arise in which it is desired to express $f(x+y)$ in a form depending on $f(x)$, some differential coefficients of $f(x)$, and some differential coefficients of $f(x+y)$. Operational formulae are obtained for such cases, and the remainders discussed.—Note on a soluble dynamical problem: Prof. L. J. Rogers. The problem is of a general type which includes Jacobi's problem of the attraction of a body to two fixed centres and various problems appropriately expressed in terms of elliptic coordinates.—A formula for the sum of a finite number of terms of the hypergeometric series when the fourth element is unity (second paper): Prof. M. J. M. Hill. The formula previously obtained by the author was

proved to hold for the sum of n terms of the series $F(\alpha, \beta, \gamma, 1)$, provided $\gamma - \alpha - \beta$ is not zero or a negative integer. It is now proved to hold in the case of the negative integer, and the appropriate modification is obtained in the case of the zero value.

Royal Astronomical Society, March 13.—Mr. H. F. Newall, F.R.S., president, in the chair.—A suggested explanation of the ancient Jewish calendar dates in the Aramaic papyri, translated by Prof. A. H. Sayce and Mr. A. E. Cowley: E. B. Knobel. The papyri are business documents relating to a Hebrew colony in Syene, and date from B.C. 471 to 410; they have duplicate dates, according to the Egyptian and Jewish reckoning, and are thus of unique importance for the elucidation of the ancient Jewish calendar, about which very little has hitherto been known. The Egyptian year and chronology are perfectly well understood. The period of the documents is extended by a Babylonian record of the eclipse of B.C. 523, translated by Father Strassmaier, in which the Jewish date is also given, and from these data a calendar has been constructed.—Double-star observations, 1902-7: W. H.

Maw. The author described his method of measuring the position angle of a bright star and faint companion. The wire was set near the bright star, at right angles to the line joining the two stars; it was then found easy to estimate a perpendicular to the wire.—Investigations on the distribution and motions of stars: F. W. Dyson. The conclusions of Prof. Kapteyn and Mr. Eddington as to two drifts of stars were confirmed, and the same result found from stars in the southern hemisphere.—The variability of the nucleus of the planetary nebula N.G.C. 7662: E. E. Barnard. A drawing made with the Yerkes telescope showed the nebula as a broad ring with a dark space in the centre, in which was a star-like nucleus. From Prof. Barnard's observations of the variability of this nucleus Prof. Turner deduced a period of 27½ days.

—Note on the discovery of a moving faint object near Jupiter: **Royal Observatory, Greenwich.** The object had been detected by Mr. Melotte on several plates taken for Jupiter's sixth and seventh satellites. It was not yet certain whether it is a new satellite or a minor planet moving very near Jupiter, but in either case it appeared of much interest.—The relative number of star images photographed in different parts of the plates for the Oxford portion of the Astrogographic Catalogue: H. H. Turner.—The perturbations of Halley's comet, 1759-1900: P. H. Cowell and A. C. D. Crommelin. Further investigations indicated that Pontécoulant's date for the perihelion passage in 1910 was somewhat too late; the most probable date is April 8.—The perturbations of Halley's comet in the past. Third paper, the period 1066-1301: P. H. Cowell and A. C. D. Crommelin. Four returns of the comet from 1066-1301 now appeared to be well identified from Chinese and European observations. It had been found that a satisfactory identification of the return of 1222 was obtained by accepting the Chinese observations as they stood, and making a change in the interpretation of the Western records.

CAMBRIDGE.

Philosophical Society, February 24.—Mr. D. Sharp, vice-president, in the chair.—Relation between the geographical distribution and the classification of the Onychophora: Prof. Sedgwick. The Onychophora comprise the single genus *Peripatus*, which was discovered in St. Vincent in the Antilles in 1826. Later, specimens of it were obtained from South Africa and Australasia, and its arthropodan nature was established by Moseley in 1874. In 1888 it was shown by the author of the present communication that the species of it fell into discontinuous groups, all capable of precise definition. At present seven such groups are known, each occurring in a definite geographical area. The geographical groups, together with the names which have been applied to them by the author, are as follows:—(1) Neo-Peripatus from the neotropical region as far south as Rio de Janeiro; (2) Congo-Peripatus from the Congo district in Africa; (3) Eo-Peripatus from Malaya (Malacca and Sumatra); (4) Capo-Peripatus from South Africa (Natal to Cape Town); (5) Melano-Peripatus from New Britain; (6) Austro-Peripatus from Australia, Tasmania,

and New Zealand; (7) Chilio-Peripatus from Chili. The author showed (1) that these geographical groups of species are natural, zoological groups, the members of which are more closely allied to each other than to those of the other groups; (2) that the distinguishing specific characters are distributed in an entirely haphazard manner among the different specific groups, so that it is quite impossible to show their phylogenetic affinities by any tree-like arrangement.—The method of impregnation in Peripatus: Prof. **Sodgwick**.—Exhibition and description of Welwitschia collected by Prof. Pearson: Prof. **Seward**.—Note on a method of demonstrating the syncytial appendages of the placental villi: Dr. **Duckworth**. The placenta provides material for a ready and quick method of demonstrating the appearance of multicellular or syncytial masses of protoplasm. Small portions of the placenta are stained in bulk, and the syncytial appendages can be easily shown by teasing out the villous processes from whence they spring.—Six new species of the Ixodoidea: W. F. **Cooper** and L. E. **Robinson**.—Note on the protozoan intestinal parasites of frogs and toads: C. C. **Dobell**.

EDINBURGH.

Royal Society, March 2.—Dr. John Horne, F.R.S., vice-president, in the chair.—A preliminary notice of new iron-bacteria: Dr. D. **Ellis**. Five new forms were described, four being new species and one—*Notofolium ferrugineum*—a new genus. They had all been discovered in the iron waters of Scotland. The methods of reproduction were the same in all, namely, a process of conidia formation, and also by transverse splitting of individuals.—The effect of load and vibrations upon magnetism in nickel; supplementary communication: James **Russell**. In determining the effect of off-and-on load the two important factors were the position on the loop and the intensity of the vibrations. In particular, the conditions under which the Villari reversal shows in nickel were studied and described.—A simplified calendar: Alex. **Philipp**. The aim of the author was to establish a perpetual calendar by arranging so that any particular day of the month would be the same day of the week. This was accomplished by making New Year's Day a day apart, not to be reckoned in the months or weeks. January would begin on what is now the second. There would be exactly fifty-two weeks of seven days, and by a slight re-arrangement four quarters of three months of ninety-one days in all. The proposed system did not interfere in any way with astronomical principles, the odd day in Leap Year to be treated like New Year's Day, as a midsummer holiday between June and July. So far as the author knew, it violated no scientific principle.

PARIS.

Academy of Sciences, March 9.—M. H. Becquerel in the chair.—The neutral alkaline and alkaline earth carbonates: M. de **Forcrand**. A re-calculation, with some new experimental data, of the whole of the thermochemical data relating to the carbonates of sodium, potassium, rubidium, cesium, lithium, calcium, strontium, and barium. The bearing of these results upon the temperatures of dissociation of these carbonates is also discussed.—The Ordovician iron minerals of Lower Normandy and Maine: M. **Ehler**.—New researches on variable stars: Charles **Nordmann**. The amplitude and form of the luminous variation of the two variable stars studied differ markedly according to the part of the visible spectrum compared.—A hyperelliptic surface of the fourth degree upon which are traced thirty right lines: E. **Traynard**.—Problems of elasticity in two dimensions: G. **Koissow**.—A case of reduction of the differential equations of the trajectory of an electrified corpuscle in a magnetic field: Carl **Störmer**.—The increase in the sensitiveness of electrolytic detectors under various influences: Edouard **Brany**. The effects produced by a rise of temperature, mechanical agitation, and gaseous disengagement in the electrolyte are separately discussed.—The theory of Brownian motion: P. **Langvin**. A simplified proof of Einstein's formula is given, and this is shown to be identical with the formula of Smoluchowski.—Singing flames reinforcing several notes: G. **Athan-**

asiadis.—A spectrophotometric arrangement: J. **Thovert**.—The action of alkaline salts with fixed base on the combustion of gases and fixed combustibles: M. **Dautriche**. The effect produced on the heat evolved by several nitro explosives by the addition of alkaline salts was studied, with especial reference to the safe use of these explosives in fiery mines. The salts of the alkaline earths, according to these experiments, appear to prevent the combustion of the carbon monoxide formed by the detonation, and thus add to the safety of the explosive.—Combustion without flame and the inflammation of gases at the extremity of a metallic tube: Jean **Meunier**.—The composition of the starch grain: Mme. Z. **Gatin-Gruzewska**. A method is given for separating the amylopectin and amylose by means of dilute alkali and subsequent neutralisation with acetic acid.—Observations on the preceding note: L. **Maquenne**.—The duration of the peroxidases in seeds: MM. **Brocq-Rousseau** and Edmond **Gain**. Seeds varying in age from two to upwards of 2000 years were examined for the presence of peroxidases. These ferments may disappear in seeds only twenty years old; two exceptional cases were found in which seeds more than 200 years old still gave the reaction for peroxidase.—The metamorphism and tectonic of the Paleozoic strata of Morvan and the Loire: Albert **Michel-Lévy**.—The eruptions of the Limagne. Seven periods of volcanic activity from the Lower Miocene to the Pleistocene: Ph. **Glangaud**.—Observation of a case of ball lightning: Isidore **Bay**. This was observed on May 26, 1907, at Saint Georges-de-Reneins. An incandescent ball was seen, lasting five minutes. On its disappearance the disruptive effects of ordinary lightning were observed.

GÖTTINGEN.

Royal Society of Sciences.—The *Nachrichten* (mathematico-physical section), part v. for 1907, contains the following memoirs contributed to the society:—

July 20.—Difference-formula for the calculation of optical systems: K. **Schwarzschild**.

October 26.—Contributions to the theory of atmospheric electricity: E. **Riecke**.

November 23.—The potential gradient in the positive glow, from observations by H. Schwenhorst: E. **Riecke**.—Comparison of the magnitudes of horizontal magnetic intensity at Potsdam and Cheltenham in the year 1904: F. **Linke**.—A calculation of the wave-length of the Röntgen rays from Planck's "energy-element": W. **Wien**.—Langbeinite ($K_2SO_4 \cdot 2MgSO_4$) and vanthoffite ($3Na_2SO_4 \cdot MgSO_4$):

R. **Nacken**.—The uniformisation of given analytical curves (ii.): P. **Koebé**.

December 7.—The nature and age of the geological displacements in the neighbourhood of the Sackberg and in the valley of the Leine at Alfeld and Elze: A. **von Koenen**.—The proper motions of the fixed stars: K. **Schwarzschild**.

December 21.—An application of the theory of invariants to the development in series of integrals, particularly rational, elliptic, and hyperelliptic: W. F. **Meyer**.

The business communications (part ii., 1907) of the same society include a report by K. **Schwarzschild** on Lambert's letters on cosmology.

NEW SOUTH WALES.

Royal Society, December 4, 1907.—Mr. H. D'ane, president, in the chair.—The effect of Polar ice on the weather: E. **Du Faur**. The author urged the necessity for frequent accurate observations on the varying position of Antarctic ice, at points within easy access of Hobart, on account of its influence upon southern climate. Provision should be made for frequent, even annual, observations to be taken for the future in the Victoria quadrant.—A comparison of the rainfall of Sydney and Melbourne, 1876 to 1905: A. **Duckworth**. The average rainfall of Sydney is given as 47.36 inches, and that of Melbourne as 24.02 inches. In Sydney, the year 1888 was the driest and 1890 the wettest, whilst in Melbourne 1898 was the driest and 1887 the wettest. If we were to judge solely from the amount of the annual rainfall of Sydney, without regard

to its periodical distribution and the intensity of its precipitation, it might be said there was no actual period of serious drought, the rainfall of Sydney being below the average of Melbourne only in the exceptional year 1888. The divergencies in the rainfall of these two great cities were so striking as to tend to make one careful in formulating any conclusions based on the rainfall experience of either city taken alone.—The Australian Melaleucas and their essential oils, part ii.: R. T. Baker and H. G. Smith. This section (part ii.) of the subject covers an investigation of the two species, *Melaleuca uncinata*, R. Br., and *Melaleuca nodosa*, Sm. The former is restricted more particularly to the interior of the continent, not having been recorded east of the dividing range. It does, however, occur on Kangaroo Island. It is mostly a slender shrub having acicular leaves terminating with slender hooks. *M. nodosa* is a coastal plant, and is a more compact shrub.—Aboriginal navigation and other notes: R. H. Mathews.—A short volumetric method for the estimation of sulphuric acid: Dr. T. Cookey. The method depends upon the volumetric estimation of the excess of barium salt left in solution after the precipitation of the sulphuric acid as sulphate of baryta. The barium is estimated by standard carbonate of soda—phenolphthalein being used as indicator. Spirit of wine is added to promote the rapid precipitation of the barium carbonate.

DIARY OF SOCIETIES.

THURSDAY, MARCH 19.

ROYAL SOCIETY, at 4.30.—On Vapour-pressure and Osmotic Pressure of Strong Solutions: Prof. H. L. Callendar, F.R.S.—On Secondary β -Rays: Prof. J. A. McClelland.—On the Measurement of the Atmospheric Electric Potential Gradient and the Earth-air Current: C. T. R. Wilson, F.R.S.—Note on the Trajectories of Killed Projectiles with Various Shapes of Head: A. Mallock, F.R.S.

ROYAL INSTITUTION, at 3.—Standardisation in Various Aspects: (1) Mechanical Engineering: Dr. R. T. Glazebrook, F.R.S.

ROYAL SOCIETY OF ARTS, at 8.—The Navigation of the Air: Dr. H. S. Hele-Shaw, F.R.S.

CHEMICAL SOCIETY, at 8.30.—The Constitution of Electronegative "Thiocyanates": A. E. Dixon and J. Taylor.—An Improved Form of Pyknometer: W. R. Bousfield.—The Quantitative Conversion of Aromatic Hydrazines into Diazonium Salts: F. D. Chattaway.—The Action of Heat on α -Hydroxycarboxylic Acids, Part iv. Racemic α -Dihydroxyadipic Acid and Meso α -Dihydroxyadipic Acid: H. R. Le Sueur.—The Spontaneous Crystallisation of Sodium Sulphate Solutions: H. Hartley, B. M. Jones, and G. A. Hutchinson.—Quantitative Relations of Salts of Thallium and its Separation from Silver: J. F. Spencer and Miss M. Le Pla.—Constitution of Hydroxyazo Compounds, Action of Diazoethane and of Mercuric Acetate: C. Smith and A. D. Mitchell.

INSTITUTION OF ELECTRICAL ENGINEERS, at 8.—New Alternate Current Instruments: Dr. W. E. Sumner and J. W. Record.

LINNEAN SOCIETY, at 8.—The Podosome of the Atlantic and the Arctic Oceans: Rev. Canon Norman, F.R.S.—A Revision of the Genus *Codopsis*: T. F. Chipp.—On the Holothurians from the Red Sea: E. Hindle.

INSTITUTION OF MINING AND METALLURGY, at 8.—Annual General Meeting.

FRIDAY, MARCH 20.

ROYAL INSTITUTION, at 9.—Recent Earthquakes: Prof. J. Milne, F.R.S.

INSTITUTION OF CIVIL ENGINEERS, at 8.—Stresses in Brick Arches: J. D. W. Ball.

SATURDAY, MARCH 21.

ROYAL INSTITUTION, at 3.—Electric Discharges through Gases: Prof. J. J. Thomson, F.R.S.

MONDAY, MARCH 23.

ROYAL SOCIETY OF ARTS, at 8.—Fuel and its Future: Prof. V. B. Lewes.

SOCIOLOGICAL SOCIETY, at 8.—The Definition of Magic: Principal Jevons.

TUESDAY, MARCH 24.

ROYAL INSTITUTION, at 4.—The Egyptian Sudan: its History, Monuments, and Peoples, Past and Present: Dr. E. A. Wallis Budge.

ROYAL SOCIETY OF ARTS, at 4.30.—The Mineral Resources of Western Australia: Hon. C. H. Rason.

FRIDAY SOCIETY, at 8.—Presidential Address: Some Aspects of the Work of Lord Kelvin: Sir Oliver Lodge, F.R.S.

ROYAL ANTHROPOLOGICAL INSTITUTE, at 8.15.—(1) Amulets Magic, with Special Reference to Charming Ceremonies and Snares; (2) Exhibition of Amulets, Objects employed by Devil Dancers and Buddhist Votive Offerings: Dr. W. L. Hildburgh.

INSTITUTION OF CIVIL ENGINEERS, at 8.—The Curzon Bridge, at Allahabad: J. B. B. The Netravati Bridge, at Mangalore: A. S. Napier.

WEDNESDAY, MARCH 25.

ROYAL SOCIETY OF ARTS, at 8.—Recent Improvements in Decorators' Materials: A. S. Jennings.

BRITISH ASTRONOMICAL ASSOCIATION, at 5.

THURSDAY, MARCH 26.

ROYAL SOCIETY, at 4.30.—*Probable Papers*:—Hakerian Lecture: The Thermal Conductivities of Solids: Prof. C. H. Lees, F.R.S.—Comparison of the Board of Trade Apsie-Standard Balance and the British Association (Apsie-Jones) Current Weigher: T. Mather, F.R.S., and F. E. Smith.—Note on the Rise of Meteorological Balloons and the Temperature of the Upper Air: A. Mallock, F.R.S.

ROYAL SOCIETY OF ARTS, at 8.—The Navigation of the Air: Dr. H. S. Hele-Shaw, F.R.S.

ROYAL INSTITUTION, at 3.—Standardisation in Various Aspects: (2) Electrical Engineering: Dr. R. T. Glazebrook, F.R.S.

CHEMICAL SOCIETY, at 5.—Annual General Meeting.—Presidential Address: The Electron as an Element: Sir William Ramsay, K.C.B., F.R.S.

FRIDAY, MARCH 27.

ROYAL INSTITUTION, at 9.—Radio-active Change in the Earth: the Hon. R. J. Strutt, F.R.S.

PHYSICAL SOCIETY, at 5.—(1) Notes on the Plug Permeometer; (2) On the Use of Shunts and Transformers with Alternate Current Measuring Instruments; (3) On Wattmeters: Dr. C. V. Drysdale.

INSTITUTION OF MECHANICAL ENGINEERS, at 8.—Combustion Processes in English Locomotive Fire-Boxes: Dr. F. J. Briselee.—Combustion Processes in American Locomotive Fire-Boxes: L. H. Fry.

SATURDAY, MARCH 28.

ROYAL INSTITUTION, at 3.—Electric Discharges through Gases: Prof. J. J. Thomson, F.R.S.

CONTENTS.

	PAGE
Coal Mining	457
Malaria and National Decay. By R. T. H.	457
Electricity Old and New. By N. R. C.	458
Our Book Shelf:—	
Macdonald: "The Oceanic Languages: their Grammatical Structure, Vocabulary, and Origin."—S. H. R.	460
Nerz: "Searchlights: their Theory, Construction, and Application."—E. E.	460
Nietzsche: "Beyond Good and Evil: Prelude to a Philosophy of the Future"	460
Letters to the Editor:—	
The Habitability of Mars.—Prof. Percival Lowell; Dr. G. Johnstone Stoney, F.R.S.	461
The Isothermal Layer of the Atmosphere.—W. H. Dines, F.R.S.	462
Classification of Secondary X-Radiators.—Dr. B. Walter	462
Gods and Godlings.—David Patrick	462
Tabulated Values of Certain Integrals.—C. E. Adams	462
Canadian Glaciers. (Illustrated.) By Prof. T. G. Bonney, F.R.S.	463
The Forthcoming Mathematical Congress at Rome. By Prof. G. H. Bryan, F.R.S.	464
Prehistoric Chemistry. By Prof. W. D. Halliburton, F.R.S.	465
Dr. H. C. Sorby, F.R.S. By J. O. A.	465
Notes	467
Our Astronomical Column:—	
A Possibly new Satellite to Jupiter	470
Observations of Jupiter during the present Opposition	471
Recent Observations of Venus	471
The System of ζ Ursæ Majoris (Mizar)	471
Mars as the Abode of Life	471
The Variable Star 31, 1907, Aurigæ	471
The Carnegie Institution. (Illustrated.)	471
Some London Problems	473
University and Educational Intelligence	475
Societies and Academies.	476
Diary of Societies	480

THURSDAY, MARCH 26, 1908.

MISLEADING SEISMOLOGY.

Earthquakes, an Introduction to Seismic Geology.
By William Herbert Hobbs. Pp. xxxi+336. (New York: D. Appleton and Co., 1907.) Price 2 dollars net.

EARTHQUAKES have come home to us of late, and we presume that the more general interest, which is now taken in them, is the cause of the publication of this book, on a subject with which the author seems very imperfectly acquainted. The keynote of the work is struck very early in the book, in a summary of the history of modern seismology, which would lead one to suppose that little of any importance had been done outside Germany and Austria; no mention is made of the Seismological Society of Japan, and it is erroneously stated that the International Seismological Association has "published at regular intervals the 'Beiträge zur Geophysik.'" The reports of the sessions of the association have certainly been published as supplementary volumes of this periodical, which is an independent publication, and one of the reasons for the abstention of those seismologists who have held aloof is that the association has been made to appear as the appanage of a private venture.

A large part of the book is devoted to the geological aspect of seismology, and in this we find what the author regards as his contribution to the science. He plots on a map the places at which earthquakes have been felt, or have exhibited a greater degree of violence, draws a series of straight lines through them, which he calls seismotectonic lines, and regards it as a remarkable fact that these lines should intersect at the points through which they are drawn. To a small extent the "seismotectonic" lines represent a truth which has long been known to students of seismology, but by far the greater number of them are mere figments of the pencil and the ruler, and it is remarkable that the author should make no reference, in this connection, to Col. Harboe's theory of extended earthquake origins, a theory which has some resemblance to that of Prof. Hobbs, but is based on more extensive data, and makes no attempt to force the origins into straight lines.

The author's unfamiliarity with the subject is most conspicuous in his treatment of seismometry, whether by observation of the effects of earthquakes or by the use of instruments. We find no mention of West's formula, or even of acceleration as the cause of earthquake damage, but we do find a most remarkable suggestion that the "simplest and one of the best" of seismoscopes may be made by setting up an ordinary lead pencil upon its end, in part immersed in a bath of sand; it is gravely added that an inch scale may be marked on the pencil by simple notches, to enable the depth of the immersion to be recorded. We can imagine the enthusiastic seismologist frantically digging out the ruins of his dwelling and anxiously determining the direction in which the

pencil, embedded, say, only three inches in the sand, had been overturned! Seriously, we wonder if Prof. Hobbs has any idea of the shock necessary to overturn a lead pencil standing on a smooth, hard surface, let alone embedded in sand; it seems a very unstable object, and easily upset, but the shock which will throw it down is severe enough to alarm many people, and even to cause damage to buildings; moreover, the direction of overthrow is now known to indicate little or nothing regarding the wave motion of the earthquake. After this it is not surprising that the description of the horizontal pendulum seismograph should be wrong both as to theory and practice.

This brief review of some of the more striking faults in the book must not be supposed to mean that it is altogether bad. As an introduction to seismology, or even to seismic geology, it is the most misleading that we know, but for the reader who comes to it with sufficient previous knowledge it contains suggestive passages, and as we perused the book we were haunted by the consciousness that its author was capable of better work; we searched for the word which would describe its character until a marginal heading, in block type, supplied the want in "crudeness."

GERMAN SCHOOL BOTANY.

- (1) *Mikroskopisches und physiologisches Praktikum der Botanik für Lehrer.* By G. Müller. Pp. xvi+224. (Leipzig and Berlin: B. G. Teubner, 1907.) Price 4.80 marks.
- (2) *Handboek der botanische Micrographie.* By Dr. J. W. Moll. Pp. xxii+350. (Gröningen: J. B. Wolters, 1907.) Price 4.25 francs.
- (3) *Grundzüge der Pflanzenkunde.* By Prof. K. Smalian. Zweite Auflage. Pp. 288; with 36 coloured plates. (Leipzig: G. Freytag; Vienna: F. Tempsky, 1908.) Price 4 marks.
- (4) *Anatomische Physiologie der Pflanzen und der Menschen.* By Prof. K. Smalian. Pp. 86. (Leipzig: G. Freytag; Vienna: F. Tempsky, 1908.) Price 1.40 marks.

(1) **A**LTHOUGH it is the general practice among teaching botanists to combine in lectures the explanation of physiological principles with descriptions of the organs involved, the combination of microscopical anatomy with physiology in a practical book is unusual. In the present instance there is complete separation into a course of microscopical exercises that occupies about three-quarters of the volume, and a set of physiological experiments and deductions. The anatomical course begins with a description of the necessary apparatus for microscopical technique, after which there follows a series of studies of the cell, stem, leaf, and root, nearly identical with the types in Strasburger's "Botanisches Praktikum," in so far as these relate to flowering plants. This part of the book is excellent, especially for teachers who wish to become thoroughly conversant with all details and skilled in manipulation. The directions are explicit, the hints on reagents and methods are practical, and the accom-

paniment of typical illustrations will be found useful. The physiological course does not produce such a favourable impression. The conduction of water and salts bulks largely in the foreground, and, seeing that it is an unsolved problem, it would seem more rational to give it less prominence. Generally speaking, the experiments appear to have been chosen rather to demonstrate dogmatic ideas than to serve as exercises practicable for general students.

(2) It is an advantage to teachers to obtain an insight into the methods adopted in other classes than their own, and botanists will welcome this introduction to the botanical courses planned by Prof. Moll for students in the University of Gröningen. In the first place the author discusses the comparative uses of demonstrations and practical classes. In practical work, although duly insisting on the necessity for good drawings, he places a high estimate on carefully written descriptions, and in this connection details his schemes for ensuring completeness by taking each character in order. A general course of histology and anatomy is outlined in a series of two hundred and fifty exercises. Some of the specimens selected for examination are innovations, and the examples of bacteria, with hints for obtaining and cultivating them, are particularly useful. On the other hand, the studies of tissues are not well defined or complete; one observes also notable omissions in the systematic types, and a somewhat too rigid uniformity in the use of tests. A special syllabus of products included in the Dutch pharmacopœia is inserted for the benefit of pharmaceutical students in the university, but the most valuable feature is the list of special investigations suitable for advanced students, that are based on, and intended to repeat, original researches. The book can be recommended to teachers having a knowledge of the Dutch language, especially during the preparation of a course of practical botany, as likely to furnish them with new ideas.

(3) This volume consists of a collation of botanical descriptions and information arranged according to the natural orders. The author's object has been to present his information in an attractive form, and to depict the *tout ensemble* of the plant. In this respect he has been quite successful, but he might with advantage have brought into greater prominence the scientific principles of classification, and would thereby have rendered the book more suitable for the purpose intended, as a text-book for use in a "Realschule." The information relates to pollination devices, seed dispersal, and general ecology, also to common insect pests, plants of economic importance, and morphological peculiarities. The sequence is similar to that prescribed by Engler, but differs mainly in the treatment of the dicotyledons, where a beginning is made with the Ranunculaceæ while the Caryophyllaceæ and orders with imperfect flowers are deferred to the end of the Archichlamydeæ. The space devoted to the cryptogams is necessarily so limited that it would have been wiser to omit them and to have extended the account of some of the phanerogams. The book is well illustrated throughout, and is provided with thirty-six coloured plates that are beautifully repro-

duced. It is a book that would be appreciated by boys and many of their elders who take a keen interest in botany.

(4) It is rightly impressed upon students that the physiology of plants and animals shows certain features in common, whence it might be expected that there would be an advantage in treating the two subjects in one volume. In the present case there is no special attempt to compare the physiological activities in the two kingdoms. The first part provides a concise account of the elements of plant physiology, but is not written with the view of stimulating practical experiment; in fact, the few pieces of apparatus represented in the illustrations are open to serious criticism. The second part, dealing with human physiology, is almost more concerned with form than function.

ELEMENTARY PHYSICS.

- (1) *The New Matriculation Heat*. Pp. viii+276; *The New Matriculation Light*. Pp. viii+282; *The New Matriculation Sound*. Pp. viii+211. (Cambridge: University Tutorial Press, Ltd., 1908.) Price 2s. 6d., 2s. 6d., and 2s. respectively.
- (2) *A First Year's Course in Geometry and Physics*. By Ernest Young. Pp. xi+169. (London: G. Bell and Sons, 1907.) Price 2s. 6d.
- (3) *A Second Year's Course in Practical Physics*. Pp. vii+148; *A Third Year's Course in Practical Physics*. By James Sinclair. Pp. viii+125. (London: B. Bell and Sons, 1907.) Price 1s. 6d. each volume.

(1) THESE manuals cover the ground of the London University matriculation syllabus in heat, light, and sound. The treatment is lucid and concise, and thoroughly in accordance with the most recent methods of teaching elementary physics. An outstanding feature of these books is the inclusion of a number of experiments which may be performed with the most simple and inexpensive apparatus, and from which satisfactory results may be obtained.

In the volume on "Heat" a chapter is devoted to methods of approximation, and this should prove extremely useful to the student in reducing observations of actual experiments or performing the numerical exercises with which the book is plentifully supplied. One notes with pleasure, in the chapter on hygrometry, the omission of the classic "Daniell." A simple method for determining the "thermal conductivity" of india-rubber is described in the chapter on heat conduction, and serves well enough to illustrate the definition to elementary students, a point which, as a rule, has been neglected in text-books of this standard. In Expt. 47, p. 135, paraffin wax is a somewhat unsatisfactory substance for the determination of melting point by the cooling-curve method, at least for beginners. On p. 140 it would have been better to use the term "latent heat of water" as synonymous with "latent heat of fusion of ice," and not "latent heat of ice."

The volume on "Light" calls for little comment. The optical formulæ are obtained by the usual geo-

metrical methods, the sign convention being made clear. The "power" of a lens is defined, and attention is directed to the optician's mode of calling a convex lens positive. "Dispersion," "the eye," and "defects of vision" are very clearly treated.

The first six chapters in the volume on "Sound" are devoted to vibratory and wave motion, and the author has succeeded in giving a very clear, and at the same time elementary, exposition of these somewhat difficult subjects for the beginner.

The three volumes form a suitable introduction to the study of physics.

(2) This book is intended for use in schools where a four years' course is given as outlined by the present regulations of the Board of Education. The book is divided into three parts. Part i. represents a first term's work in geometry and physics; part ii. a second and third term's work in geometry; part iii. a second and third term's work in physics. The book is a copious collection of examples and practical exercises in illustration of the chief elementary geometrical properties of the straight line, parallels, triangles, quadrilaterals, polygons, and circles. The construction and use of scales, graphs, measurements of length, area, volume, and density are also dealt with. No instructions are given as to the method of using the instruments employed in performing the various exercises. These are left for the teacher to supply. The book should prove extremely useful as a class-book, the multiplicity and variety of the exercises being a boon to any teacher for purposes either of work in class, in the laboratory, or at home.

(3) These are two elementary laboratory text-books forming, as their titles imply, a second and third years' course in practical physics for schools. The second year's manual deals chiefly with heat, and contains descriptions of methods of performing upwards of seventy experiments, the subjects treated including thermometry, measurement of coefficients of expansion, calorimetry, conduction, convection, radiation, solution, distillation, and crystallisation. In addition, questions and supplementary exercises are given after many of the experiments. The book strikes one as being hurriedly compiled, the diagrams in very few instances being referred to in the text. Again, on p. 81 a wire 12in. long $3/32$ in. diameter is to be bent 2 cm. from the end. Is such confusion intended? The experiments described on conduction and radiation are novel, use being made of an indicating paint prepared by Mr. Walter Jamieson. This paint, which is colourless at ordinary temperatures, turns green when heated, the green colour disappearing on cooling. The range of sensitiveness may be from 80° C. to 21° C. Objection must be raised to the designation of the curve in the diagram on p. 82 as "heat-curve." Temperature-gradient would be better. We must disagree with the remark on p. 42, footnote; it is certain a boy will be more readily convinced of the anomalous expansion of water by use of the apparatus described in the text (previously described by Mr. H. E. Hadley in the *School World* for June, 1901) than by the performance of Hope's experiment. The diagram of the constant volume air

thermometer on p. 53 is unnecessarily complicated, and does not appear any more exact than that on p. 50.

The third year's course is devoted entirely to optics, and is similar in plan to the manual on heat. There are upwards of fifty experiments which may be performed with simple apparatus, and the book contains many supplementary exercises and questions. Experiments 6, 7, 8, pp. 11-19, on photometry are misleading, viz., "To find the relation between the illuminating power and the distance of sources of light." The "intensity of illumination" at a point due to a given source will vary with the distance, but the "illuminating power" of the source remains the same.

OUR BOOK SHELF.

The Mechanism of Speech. Lectures delivered before the American Association to promote the Teaching of Speech to the Deaf by Alexander Graham Bell. Second edition. Pp. xv+133. (New York and London: Funk and Wagnall's Company, 1907.) Price 1.20 dollars net.

THIS is the second edition of a work already reviewed in NATURE, December 27, 1906 (vol. lxxv., p. 196). The first edition was printed during the author's absence in Europe, and he had no opportunity of revising the proofs. As the printers could scarcely be expected to be familiar with the somewhat complicated symbols used by the author's father, Melville Bell, a number of typographical mistakes had crept in. These have now been corrected. A full account is given of Mr. Melville Bell's ingenious system of symbols, which are intended to express the position of various parts of the vocal apparatus in the production of articulate sounds, and illustrations are afforded of the methods by which deaf children can be led to understand the meaning of these symbols, and are thus guided in the operation of placing their vocal organs in the position required for a given word. By patient training and by following the judicious maxims of Mr. Graham Bell a wonderful degree of success has been attained in the education of the deaf.

Mr. Melville Bell's symbols express words, not in letters, nor in the wave vibrations revealed by the phonograph or gramophone, but in forms that indicate precisely the physiological position of the articulating mechanism necessary for the production of a given sound. A first glance at these strange symbols gives one the impression of the system being too complex for practical purposes, but with the aid of Mr. Graham Bell's instructions it soon becomes easy. The writer in a short time found that he could both write and interpret the symbols. One can readily see how the system might be of use to travellers, as, by means of the symbols, they could write down the sounds of an unknown tongue and reproduce them. A knowledge of this system and the use of a phonograph would be invaluable to those who desire to register the articulate expressions of savage tribes. JOHN G. MCKENDRICK.

The Moths of the British Isles. By Richard South. First Series, containing the Families Sphingidæ to Noctuidæ. Pp. vi+343, plates 159, text-figures 24. (London: F. Warne and Co., 1907.) Price 7s. 6d. net.

BOOKS on British butterflies and moths are now plentiful enough, but we have never seen any which have pleased us so well as the series of which this book is the second volume. It is true that technical-

ties, even the characters of families and genera, are almost entirely omitted, but the amount of practical information is nearly as great as that to be found in the more bulky work of Mr. Barrett, who dealt with about 100 species in each volume. No popular book, of course, can compete with the huge encyclopædic work of Mr. Tutt; but then he often devotes 40 or 50 pages of very closely printed but large 8vo. pages to a single species, and his work is only slightly illustrated. Mr. South, however, gives us a profusion of admirable illustrations, and much bulk is saved by an arrangement by which the plates (except the front-piece) are on opposite sides of the same leaf, in most cases coloured figures of moths occupying one side and plain figures of transformations the other. The introduction is good, and includes useful figures of antennæ and wing-markings, &c., and also remarks on collecting.

The general arrangement followed is that of Staudinger's catalogue of 1901. One point of interest in successive works on British Lepidoptera is the shifting of localities for species, combined with the actual extinction of some, and the discovery or naturalisation of others. The comparison of a series of successive works like those of Petiver, Haworth, Stephens, Westwood and Humphreys, Stainton, and Barrett would bring this out very strongly. Most of the best localities of the older London entomologists has been built over or otherwise destroyed; the best locality for "blues," &c., near Brighton, is now turned into allotments; and several species of butterflies and moths common in many parts of England only fifty years ago are now on the verge of extinction as British species.

We must not omit to mention that Mr. South does not share Stainton's prejudice against English names. In Stainton's time it might have been necessary to discourage their use as against that of Latin names; but at present the latter are so familiar that it is no longer necessary. One suggestion we should like to make. The index is good, but we think a table of contents would also be useful; and if restricted to headings and families, it need not occupy more than a single page.

W. F. K.

Physiologie und Anatomie des Menschen mit ausblicken auf den ganzen Kreis der Wirbeltiere. By Dr. Felix Kiernitz-Gerloff. Pp. vi+130. (Leipzig: B. G. Teubner, 1907.) Price 3 marks.

This is a small elementary text-book with a scope similar to that of Huxley's "Elementary Lessons in Physiology." It presents clearly and accurately the main facts of physiology and anatomy from a general educational point of view. While the skeleton, muscles and joints are dismissed with appropriate brevity, the central nervous system, sense organs, excretory organs, and the alimentary, respiratory, and circulatory systems are treated in some detail. As opportunity offers, matters pertaining to general health find suitable mention. The text is lightened by frequent and interesting references to comparative anatomy. The illustrations are taken from standard text-books of anatomy, and are both numerous and well chosen. Although the book is primarily intended for students in a school of agriculture, it ought to have a wide and general circulation.

W. W.

The Elements of Geography. By J. H. N. Stephenson. Part 1, General Geography. Pp. xiii+160; with illustrations and maps. (London: Edward Stanford, 1908.) Price 3s. 6d.

WHAT Mr. Stephenson describes as "general" is more commonly known among teachers as "physical" geography; but since an understanding

of the broad principles with which he deals in this attractive book must precede a study of the geography of special areas, his title sufficiently describes the character of his chapters. The section styled "organic" geography will prove especially useful to teachers as indicating the way in which man's development has been modified by his surroundings, and the manner in which man in his turn has influenced the character and distribution of life on the globe. The book is exceptionally rich in well-executed maps which will increase greatly its usefulness as a class-manual. The volume may be recommended to the careful attention of teachers of geography.

Lehrbuch der Chemie und Mineralogie für die vierte Klasse der Realschulen. By Franz von Hemmelmayr and Dr. Karl Brunner (the Mineralogical Portion by Heinrich Leitenberger). Third edition. Pp. 180; with two coloured plates. (Vienna: F. Tempsky, 1906.) Price 2kr. 10hel.

THIS is an elementary class-book for use in the fourth class in the Austrian State schools, that is, for boys of about twelve or thirteen years of age. It covers much the same ground as the usual elementary class-books on chemistry. In the longest portion of the book, that on inorganic chemistry, however, there are added brief descriptions of the more important minerals which yield the elements under discussion; the pupil is thus at the same time told how chemical compounds and elements occur in nature. Figures are given of crystals of these minerals, but several of them have been placed upside down in the text. There is a short section on organic chemistry, in which prominence is given to compounds of everyday use. The book is very well and clearly printed on good paper.

LETTERS TO THE EDITOR.

[The Editor does not hold himself responsible for opinions expressed by his correspondents. Neither can he undertake to return, or to correspond with the writers of, rejected manuscripts intended for this or any other part of NATURE. No notice is taken of anonymous communications.]

The Cotton Plant.

THE full acknowledgment Sir George Watt has given to the slight assistance which I was able to afford him—in those portions of his book which deal with Egyptian cotton—renders criticism difficult, but there are a few points arising from Lieut.-Colonel Prain's recent letter (February 6, p. 318) which seem to call for comment.

While not possessing any general knowledge of the genus *Gossypium*, I have had occasion during the last three years to grow, and to examine in some detail, a number of pedigree cultures of Egyptian cotton—as well as of Uplands and others—in researches on Mendel's law. One result of this work is that I can fully endorse your reviewer's argument that the cotton plant can be studied successfully for systematic purposes in living material only. The herbarium method has many limitations, the most conspicuous of which is perhaps the tendency to take the extreme form of some character which has a large range of fluctuation as the differentiating mark of a variety or species.

Colonel Prain affirms that the ideas of your reviewer as to the meaning of the terms "species" and "variety" do not accord with accepted usage. My general position is the reverse of Colonel Prain's, in that I am unable to obtain any idea as to the nature of species in the genus *Gossypium* by studying the names accorded by Watt to certain plants with which I am acquainted. A particular case is that of the Sudanese tree cottons from Senaar, referred to in the "Wild and Cultivated Cottons of the World" by my numbers 213-1 and 213-2 (pp. 113 and 138). These were supplied to me by Mr. A. G. Braun, of the Woods and Forests Department, Khartoum, in a

sample of seed which had been sent from Senaar Province. This sample was sown at Ghizeh, and the material sent to Kew was taken from two adjacent plants in the same row, these being plants developed from embryos which had ripened on a tree in Senaar. The reason for sending material from two different plants was because this row showed two distinct leaf-forms, some of the plants having much wider leaf-lobes than the others, and these two types were represented by 213-1 and 213-2. In no other respect could any distinction be drawn between the two types, at least on any character within my grasp; moreover, they all flowered within the same week, ripened within the same week, grew to a remarkably uniform height, and had similar habits of growth; with the one exception of the leaf-shape they were far more alike than a similar group of plants taken from a field of any variety of Egyptian cotton. These two forms were separated by Watt into *G. arboreum* and *G. Nanking*, because "a yellow-flowered *G. arboreum* with deeply lacinate bracteoles and three glands on the under surface of the leaf would destroy the specific isolations" (p. 138). I incline to think that the laciniation of the bracteoles and the glandulation of the leaves should have been made the subject of comparative study—in order to ascertain their capacity for fluctuation—before such erratic characters were entrusted with the responsibility for this violent separation of the two forms into two separate species. Such comparative study would at least have been commenced had these plants been seen growing side by side in my plot.

On the other hand, we find on p. 181 that Moqui Indian cotton from Arizona (209-3) and "Hindi" weed cotton of Egypt (55-A) are placed together under *G. punctatum*. Waiving the query as to why Hindi, a naked-seeded cotton, should be placed in the fuzzy-seeded section, I should like on other grounds—but in all diffidence—to advance the opinion that if the two strains could be grown together at Kew, or examined side by side on my plot in Egypt, they would be systematically removed from one another by a wide interval.

The employment of common names has also been mentioned by Colonel Prain; the following instance, therefore, does not seem altogether pointless—the plant referred to as 56.C.2 (p. 224) came from a sample of Afifi cotton, and bears lint of the brown Afifi colour; this colour is the characteristic and sole morphological distinction of Afifi from Abbassi, the latter bearing white lint, so that 56.C.2 could by no possibility be described legitimately as "close to Abbassi or Afifi."

The cultivated varieties of Egyptian cottons—and probably of Uplands—consist of many different strains mingled together and cross-fertilised, resembling one another in a few obvious characters of economic importance. Thus, on p. 224, Watt describes the strain 142, plant A, as being distinct from the Abbassi plant described in par. 2 of the same page. In point of fact, No. 142 was taken from a prize sample of Abbassi.

Though I wish to see an exact method adopted for the investigation of this labyrinthine genus, such method to be based on pedigree culture and statistical inquiry, I am nevertheless grateful to Sir George Watt for having gathered together the mass of detailed information which is to be found in his book, and I hope—with Colonel Prain—that we shall not have to wait long for the publication of further researches on the subject.

W. LAWRENCE BALLS.

Cairo, February 27.

In the courteous letter in which Mr. Balls exercises his right to criticise details in Sir G. Watt's work on cotton, as to which he considers himself a competent judge, he gives expression to some misapprehension that it may be well to remove.

It has not been affirmed that the ideas of the writer of the review which appeared in NATURE for January 16 as to "species" and "varieties" do not accord with accepted usage. What it was necessary to point out was that the reviewer had not made it clear that his interpretation of these words accords with accepted usage. There are two passages in the review in which the words are dealt with together; in one passage they are so used

as to imply that the status of a variety is the same as that of a species; in the other they are so used as to indicate that a species is subordinate in status to a variety. The ideas of the reviewer may be as precise as those of Mr. Balls; they may, on the other hand, be as loose as his own phraseology; he has given us no means of deciding.

The position assumed by me has already been explicitly stated. I have reserved perfect freedom of judgment as regards the acceptance of Watt's conclusions, not as to the limits of species in the genus *Gossypium* alone, but as to all the issues involved. When he explains that his general position is the reverse of this, it will be felt that Mr. Balls does himself an injustice.

The name of the distinguished public servant referred to by Mr. Balls is Mr. A. F. Broun, and is not as given in Mr. Balls' letter.

D. PRAIN.

The Isothermal Layer of the Atmosphere.

IN his letter in NATURE of February 27 Mr. Dines asks why the adiabatic conditions which prevail in the lower part of our atmosphere should suddenly cease at a height of about 40,000 feet. The answer comes more readily if the question is altered to, Why does the isothermal condition of the outer layers of our atmosphere suddenly cease at about 40,000 feet? The isothermal condition or even increased temperature with height is the condition which would naturally prevail in an atmosphere surrounding a smooth sphere. For if the sphere is a very hot one its entire gaseous envelope should acquire its temperature, whereas if the solid sphere, like our earth, is cold, and if heat from the sun is warming the atmosphere by radiation, one may expect the outer layers to be warm and the lower layers to be the coldest ones. If, however, there are irregularities, as, for instance, mountain chains on the earth's surface, then the air, whenever it is forced over them, parts with its moisture as it rises on the one side and then descends on the other side as a dry and hot *Föhn*, in which wind the conditions are perfectly adiabatic, the temperature gradient rising steadily with decreasing height. It seems, therefore, that it is our mountain ranges which prevent the isothermal condition from descending below the height at which effective mixing or moisture removing occurs.

This leads to the conclusion that if at one time our mountain ranges were lower than at present, the isothermal condition and its low temperature will also have been lower than at present. This may have been the case during Glacial periods. On the other hand, during tropical periods our mountain ranges may have been higher than they are at present; the isothermal condition will have ended at a higher level, and the steady rise of temperature below this boundary will have resulted in a very high temperature on the earth's surface.

I remember discussing this subject about twenty years ago at Aix-la-Chapelle with Dr. A. Ritter, who had only recently in Wiedemann's *Annalen* (vols. v.-viii., "Heights of Atmospheres and Conditions of Nebulæ") dealt with it very exhaustively. If I am not mistaken, it was the *Föhn* wind which had first led to these inquiries, but, strange to say, Dr. Ritter relied on molecular motions for the necessary mixing of the layers. This may have been due to his feeling that if isothermal conditions were conceded, an interstellar atmosphere would have to be postulated. We therefore almost naturally disagreed as to the possibility of condensing the so-called permanent gases, which fact had not then been accomplished. My view was that if the adiabatic condition existed up to the outer limits of our atmosphere, then, at the zero temperature to be found there, both gases would condense and sink to the lower levels, to be followed by further and further layers until the whole atmosphere would be deposited on the earth's surface. Dr. Ritter merely pushed this difficulty further away by saying that, even if oxygen and nitrogen could be condensed, our atmosphere might nevertheless be surrounded by hydrogen. Now that hydrogen has been condensed, helium would have to take its place, or, and this is a view not easily accepted, our earth may be surrounded by a very attenuated and possibly warm interstellar atmosphere. I think that the recent experiments

to which Mr. Dines refers by showing that the conditions of the outer atmosphere are isothermal, and Sir James Dewar's experiences with non-conducting power of high vacuum are leading to the conclusion that there is a comparatively warm interstellar atmosphere.

C. E. STROMMEYER.

"Lancefield," West Didsbury, March 3.

ONE would naturally expect the upper part of any large mass of fluid to be the warmer, because that condition is a possible one, whereas the converse is not possible as a permanent condition, since it involves a warmer, and therefore in general a lighter, portion of the fluid remaining under a heavier. But when dealing with a gas it is necessary to use the term "warmer" in a special sense, for which the convenient expression "potentially warmer" has been used. This means that the temperature is referred to some standard pressure, and taken as what it would be after adiabatic reduction to that pressure. In this sense the air gets rapidly warmer as we ascend, at the rate of about 0.4°C . to each 100 metres, but if there were sufficient mixing we should expect to find the same potential temperature throughout, just as in a pond the heavier water is found at the bottom, but in a fast-running stream the specific gravity and the temperature are the same throughout.

We have no evidence at the present time to show how the isothermal layer is influenced by a mountain range, but there are immense stretches of sea and land so far removed from any high mountains that we can hardly suppose any such influence to exist over them.

It must be remembered that the chief heating and cooling effects on our atmosphere are applied at the bottom by contact with the ground. Pure air is almost pervious to radiation. There may be sources of heat to the upper layers; the electric currents which produce the aurora have been suggested, but I do not see that this affords any explanation of the sudden cessation of the temperature gradient.

The well-known phenomena of shooting stars apparently quite negative the suggestion of a stellar atmosphere; beside which, unless it were moving with the earth, in which case it would cease to be stellar, such an atmosphere would produce an enormously increased pressure on the forward side of the earth as it pursued its course round the sun.

W. H. DINES.

The Penetrating Radiation.

IN a letter to NATURE of February 13, the question is raised by Mr. W. W. Strong whether the larger proportion of the penetrating radiation may not arise from active matter in the air rather than in the ground. Unless the earth's supply of active matter is augmented from without, or unless it arises in a manner at present unknown, the question may be negatived, and a numerical answer given with some approach to accuracy.

Strutt has found about 3×10^{-12} grams of radium as the average amount present in 1 c.c. of soil. I have found about 10^{-16} grams of radium to be a measure of the amount of radium emanation present per c.c. of the atmosphere (*Phil. Mag.*, December, 1907). These two quantities are nearly proportional to the amounts of radium C produced per c.c. in earth and in air. The ratio is 30,000 to 1.

But McClelland and Wigger have found that the coefficients of absorption of the γ rays are proportional to the densities of the absorbers, so that the absorptions of the γ rays from radium C by soil and by air are as their densities, about 2000 to 1.

Now it has been proved (*Phil. Mag.*, September, 1906) that, for a given electroscopie near the earth's surface, the penetrating radiations from earth and from air will be in the ratio Q/A to Q'/A' , where Q , Q' are the quantities of radium per c.c. in soil and air, and A , A' are the coefficients of absorption of the γ rays by soil and air.

Hence the penetrating radiations from the radium C in ground and from that in the air are in the ratio of two ratios above stated, namely, 15 to 1.

Moreover, the radium C in the air is carried earthwards, not only by falling rain, snow, dust, or smoke, but by the potential difference in the atmosphere. The active matter

on the earth's surface is thus augmented and that in the air decreased.

Observers in both hemispheres have found evidence of thorium C in the air, the activity being about half that of the radium C present. The emanation of thorium decays about 6000 times as fast as the emanation of radium, and has a poor chance of escaping from the soil, so that (1) the amount of thorium C in the ground probably exceeds the amount of radium C, and (2) the thorium C in the ground will be more than fifteen times that in the air.

We may conclude, then, that at most localities the penetrating radiation due to active matter in the air is less than one-fifteenth of that due to active matter in the earth.

A. S. EVE.

McGill University, Montreal, March 3.

Mosaic Origin of the Atomic Theory.

THE recent correspondence on the subject of the identity of the inventor of the atomic theory has led me to think that the following quotation from one of the foremost English scholars of the seventeenth century is worthy of some passing notice in this connection. Ralph Cudworth, D.D. (1617-1688), was the author of a colossal monument to Greek philosophy, the "Intellectual System of the Universe." A smaller work of that author, which was published posthumously (1731), contains the following paragraphs, which throw a glimmering light (new, probably, to most eyes) on the historic continuity of ancient philosophy and "modern" science—

"1. Wherefore we have made it evident, that that very *Mechanical or Atomical Philosophy*, that hath been lately restored by *Cartesius* and *Gassendus*, as to the main Substance of it, was not only elder than *Epicurus*, but also than *Plato* and *Aristotle*, nay, than *Democritus* and *Leucippus* also, the commonly reputed Fathers of it. And therefore we have no Reason to discredit the report of *Posidonius* the Stoick, who, as *Strabo* tells us, affirmed this *Atomical Philosophy* to have been antienter than the *Times of the Trojan War*, and first to have been brought into *Greece* out of *Phenicia*. If we may believe *Posidonius* the Stoick, the *Doctrine of Atoms* is antienter than the *Times of the Trojan War*, and was first invented and delivered by one *Moschus* a *Sidonian*, or rather a *Phenician*, as *Sextus Empiricus* cites the Testimony of *Posidonius*. *Democritus* and *Epicurus* invented the *Doctrine of Atoms*, unless we make that *Physiology* to be antienter, and derive it, as *Posidonius* the Stoick doth, from one *Moschus*, a *Phenician*. And since it is certain from what we have shewed, that neither *Epicurus* nor yet *Democritus* were the first Inventors of this *Physiology*, this Testimony of *Posidonius* the Stoick ought in Reason to be admitted by us.

"2. Now what can be more probable than that this *Moschus* the *Phenician*, that *Posidonius* speaks of, is the very same Person with that *Moschus* the Physiologer, that *Jamblichus* mentions in the *Life of Pythagoras*, where he affirms, that *Pythagoras* living some time at *Sidon* in *Phenicia*, conversed with the Prophets that were the Successors of *Mochus* the Physiologer, and was instructed by them. He conversed with the Prophets that were the Successors of *Mochus* and other *Phenician Priests*. And what can be more certain than that both *Mochus* and *Moschus*, the *Phenician* and *Philosopher*, was no other than *Moses* the Jewish Lawgiver, as *Arcecius* rightly guesses. It seems that it ought to be read *Moschus*, unless any had rather read it *Mochus* or *Moses*. Wherefore according to the Antient Tradition, *Moschus* or *Moses* the *Phenician* being the First Author of the *Atomical Philosophy*, it ought to be called neither *Epicurean* nor *Democritical*, but *Moschical*, or *Mosaical*."

Dublin, February 26.

JOHN KNOTT.

Tabulated Values of Certain Integrals.

IN reply to the letter of Mr. C. E. Adams in NATURE of March 19, a table of the values of the integrals required will be found in Airy's "Undulatory Theory of Optics" (Macmillan and Co., Ltd., 1877) on p. 158.

HARRY M. ELDER.

41 Netherhall Gardens, N.W., March 20.

NOTES ON ANCIENT BRITISH MONUMENTS.¹VII.—THE ABERDEEN CIRCLES (Continued).²

IN December, 1906, I gave an account of my measures of four examples of a very special type of circle which is only to be found, so far as I know, in Aberdeenshire. They were described in relation to other circles by Mr. Lewis in his paper on the stone circles of Scotland. My wife and I again went to Aberdeen last autumn and measured another twenty-five, leaving, I believe, still more than a hundred to be examined.

The survey last year has greatly increased the interest in them, and I hope to show that a complete inquiry into them may advance science in many directions, especially if other allied questions are included in the research.

The instrument employed in the reconnaissance, for time did not allow of a complete survey, was a compass clinometer of Barker's pattern, giving azimuths and angular heights of the horizon, say, to half a degree, a reading quite as fine as can be hoped for, considering the rough condition of the monuments, and the presence of trees on the horizon in many cases. As I said in my 1906 notes, observations of the height of the horizon in winter, when the trees are leafless, are very desirable.

In the observations last year, the orientation was determined by attempting to find the direction of the line across the circle at right angles to the face of the recumbent stone. Last year I worked differently.

The method of observation adopted was to measure the azimuth of the line lying along the common N. and S. surfaces of the supporters and recumbent stone, and in the eastern direction where possible. When there was no common line, supporters and recumbent stone were dealt with separately. In some of the complete and undisturbed triliths the correspondence of the azimuths of both surfaces showed that immense care had been taken in selecting and "planting" the stones.

The mean of the azimuths thus obtained, deducting 90° , gave the direction of the observing line across the circle.

In some cases it seemed as if the circle builders had got this line in the first instance by erecting two stones on the opposite side of the circle about the same distance apart as the two supporters—a kind of avenue, the surfaces of the recumbent stone being placed at right angles to this line.

This premised, I next give a comparison between the Cornwall and Aberdeen monuments:—

(1) Assuming that the recumbent stone in Aberdeenshire was used as a directrix, like the outstanding stones of the Cornish and Gorsedd circles, all the conclusions I arrived at in Cornwall and on Dartmoor are abundantly confirmed.

(2) I have examined no circle in Aberdeenshire the astronomical use of which, with one or two exceptions to be referred to later, is not perfectly obvious in the light of former work.

(3) The directions indicated by the Aberdeen recumbent or directing stones are generally the same as those indicated by the outstanding stones in Corn-

wall. The exceptions are that the cardinal points N. true and W. true are indicated in the former.

(4) The N. and the W. true alignments may indicate an advance in astronomical knowledge. The N. alignments suggest that time at night was determined by circumpolar stars. The W. alignment shows that the equinoxes were fixed as well as the solstices.

(5) Of the twenty-nine circles I have examined, fifteen are clock-star circles, two are May-year, and three solstitial. Of special circles we have four facing N. and one facing W.

(6) Arcturus and Capella were used as clock-stars in Cornwall; in the higher latitude of Aberdeen Castor might have been used.

(7) So far, and quite provisionally until a larger number of circles is examined, I think Castor was not used.

(8) In the clock-star circles the azimuths range from N. 4° E. to N. 29° E. These azimuths, taking the heights of horizon into account, give us N. declinations from $34^\circ 45'$ to 31° . If Capella is in question, the dates lie between B.C. 1200 and B.C. 2000; if Arcturus, B.C. 950 and B.C. 250. Mean dates are:—Capella, B.C. 1600; Arcturus, B.C. 600.

I append a diagram which shows the connections

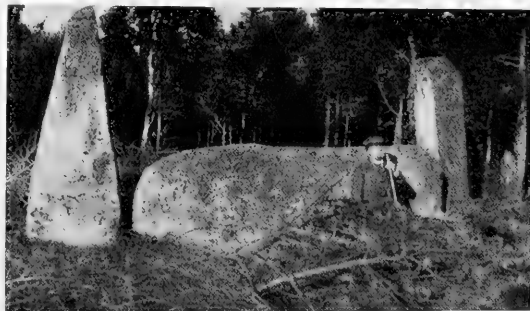

FIG. 20.—The recumbent or directing stone and supporters of the Cuthie Muir Circle, a normal example.

existing between the azimuths, the elevation of the horizon—both measured quantities—and the declinations, and dates of the use of the clock-stars. The numbers on the curves refer to the fifteen clock-star circles enumerated below:—

1, Braehed Leslie; 2, Lylodge; 3, Loudon Wood; 4, Tomnagorn; 5, Wanton Wells; 6, Old Keig; 7, South Fornet; 13, Nether Boddam; 8, Aikley Brae; 9, Castle Fraser; 10, New Craig; 11, Loanhead of Daviot; 12, Kirkton of Bourtie; 14, Cuthie Muir; 15, Eslie the Greater.

Note that on the diagram the circle (13) is misplaced. The azimuth should be $21^\circ 15'$, not $11^\circ 15'$; consequently the (13) circle should be moved along the "2° hill" curve until it touches the circle (5).

As an illustration of the use of the curve, take the case of the Cuthie Muir circle, number 14. The true azimuth across the circle, i.e. at right angles to the recumbent stone, was found to be N. $18^\circ 55'$ E., and the elevation of the horizon in that direction 4° . Projecting the point where the $18^\circ 55'$ azimuth ordinate intersects the " 4° hill" curve, on to the declination scale, we get $34^\circ 42'$ N. as the declination. Referring to the time scales for Arcturus and Capella, it is seen

¹ Continued from p. 416.

² NATURE, vol. LXXV., p. 150.

that the former had this declination in 920 B.C., the latter in 1300 B.C.

(f) There is so far no absolute demonstration as to which of the stars in question was used, or whether they were used at different times. Some light may be thrown on this point if the approximate dates

conditions at Aberdeen are such that no direct solution of the problem is so far possible.

But there are some sidelights.

Against the older date is the fact that the Aberdeen circles, even May-year circles, differ in the method in other parts of Britain, including the west coast of Scotland, at the earlier date. But the presence of the recumbent stone is not the only difference; the central stone of the Gorsedd is generally replaced by a cairn, or rings or mounds of stones. The true N. alignments at Dyce, Whitehill Wood, Raes of Clune and Candle Hill (Insch) have no counterpart in the South, and they may be held to indicate possibly an advance in the manner of determining time at night, and therefore an erection at a more recent date.

Again, the work at the various circles showed that the Aberdeen system of alignment is far inferior to that of the employment of an outstanding stone some distance away from the circle as in the Cornish monuments. But it must not be taken for granted that this inferior method of alignment meant an inferior knowledge of astronomy, which we should be justified in associating with an earlier date. I am rather inclined to attribute it to the fact that an exact knowledge of the length of the year and of the number of days in each quarter having been gained, exact alignments became less necessary. As time went on, the circle became of less importance as an astronomical instrument, though its other uses remained, and this latter view seems strengthened by the fact that in Aberdeenshire the circles are very frequently located on the tops of low hills, convenient places of assembly, whereas in Cornwall this, so far as I now remember, did not often happen. The Aberdeenshire circles, indeed, are generally at a much lower level, among the cultivation. It was chiefly the astronomical requirement of a clear horizon which was fulfilled in Cornwall and Dartmoor, at heights from 1000 to 1500 feet.

Another strong argument against the older date is the absence of cromlechs in the Aberdeenshire district. May we not take the absence of the cromlech and the presence of the cist as another proof of modernity? By cist I mean an oblong grave as opposed to the "chambered cairns" of some authors, which were as obviously not built as graves merely. These "chambered cairns," I take it, are really the interiors of barrows, and are large examples of cromlechs. It is immaterial whether the barrows were built of stones or earth to make the chambers rain-tight. This would depend upon which was most handy—stones

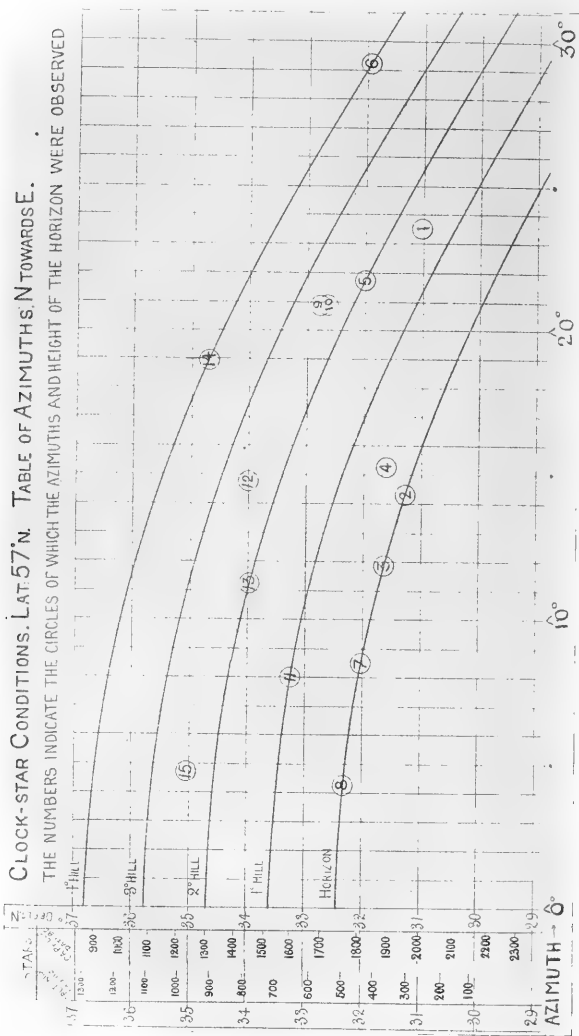

to the solstitial circles at Midmar, Sunhoney and Stonehead can be determined, using the change of obliquity.

This question of date is, of course, one of surpassing interest, and it is not a little curious that the

in Scotland, chalk at Stonehenge, earth in Cornwall.

Now while "cists" are common to Scotland, Dartmoor and Cornwall, the "chambered cairn" or cromlech is in Scotland special to the west coast. I do not know at present whether there is any representative of it nearer to Aberdeen than Callernish or Stenness. The difference between the east and west coast of Scotland is thus strongly emphasised, and the view of a difference of time in the building operations is strengthened.

I now return for a moment from the side-lights to the clock-star conditions, in order to give a table of the measurements, from which the declinations of the stars were determined by means of a curve connecting azimuth and declination, for different elevations of the horizon, for the general latitude of 57° N.; consequently the measurements are not final, but are sufficiently accurate for a preliminary discussion.

Between 2000 B.C. and 1 B.C. Arcturus and Capella were the only first-magnitude stars to come within the declination range shown in the table, and, as my results show that they were used as clock-stars in Cornwall and Devon, I consider that the evidence in their favour warrants the assumption that one of them was used as a clock-star by the circle-builders of Aberdeenshire. I give the dates for both.

Circles at—	Azimuths		Dates B.C.	
	Magnetic, mean of observations	True, at right-angles across circle	Elevation of the horizon	D. declination N.
Braehead Leslie...	132 20' N.	23 35' E.	1 1/2	30 58 250 2000
Leylodge ...	123 0' N.	14 15' E.	0	31 18 330 1940
Loudon Wood ...	120 40' N.	11 55' E.	0	31 38 370 1890
Tonnagorn ...	124 0' N.	15 15' E.	3/4	31 42 390 1860
Wanton Wells ...	130 30' N.	21 45' E.	2	31 52 420 1830
Old Keig ...	138 0' N.	29 15' E.	4	31 55 430 1820
South Fornet ...	116 48' N.	8 3' E.	0	32 4 450 1800
Nether Boddam...	130 0' N.	21 15' E.	2	32 8 460 1790
Aikey Brae...	113 0' N.	4 15' E.	0	32 16 500 1760
Castle Fraser ...	129 36' N.	20 51' E.	2 1/2	32 42 570 1680
New Craig ...	129 34' N.	20 49' E.	2 1/2	32 43 570 1680
Leanhead of Daviot...	116 45' N.	8 0' E.	1	33 14 660 1580
Kirkton of Bourtie ...	123 30' N.	14 45' E.	2 1/2	33 57 770 1460
Cothie Muir ...	127 40' N.	18 55' E.	4	34 42 920 1300
Esie the Greater ...	113 30' N.	4 45' E.	2 1/2	35 5 980 1230

In future notes, after referring to some more "side-lights," I shall give the measurements of the May-day and solstitial circles.

NORMAN LOCKYER.

PROPOSED ALTERATION IN THE CALENDAR.

THE last great alteration in the calendar was that which was known as the Gregorian Reformation. It was promulgated in 1582, and at once accepted in all countries which were under the Roman obedience in ecclesiastical matters, but only gradually adopted by those belonging to the Reformed Western Church (which are all usually called Protestant, though that term strictly pertains to the Lutherans only), whilst the Eastern Church adheres still to the old Julian style.

Now it is often forgotten that the change then made was two-fold, the two parts having really no reference to each other, and the assertion frequently

made that the Gregorian calendar was constructed, or nearly so, to agree with the astronomical length of the year, applies to only one of these changes, the other, which made a violent hiatus in the succession of days, being effected with a totally different object. For if the year were to be assigned its true length and not the 365 1/4 days decreed by Julius Cæsar, it would at first sight have seemed most natural to choose a convenient epoch, such as the end of a century, and simply arrange the omission of a leap-year at certain stated times from that. (Here we may parenthetically remark that a regulation to drop a leap-year at the end of each 132nd year would have been more accurate, and quite as simple as that actually adopted.) But it was also thought necessary to bring back the vernal equinox to the date it occupied, not at the Christian era, but at the time of the Council of Nicæa in the fourth century. Hence ten days were omitted from the current sequence, and when England came into line with other western countries, eleven days were omitted in 1752. This, of course, makes great care necessary in comparing events as given in English and Continental narratives between 1582 and 1752.

The change now proposed, and recently brought before the House of Commons by Mr. Pearce, is of a much more drastic kind. It is not a reformation of the Gregorian calendar as regards the length of the year (and a small change of the rule, as already mentioned, would improve its accuracy at long intervals), but a proposal to alter the succession of the days of the week and of the month to secure a degree of symmetry in their correspondence, and an equality in the four quarters of the year. Thus the first of January and the leap-year day, which, however, is to be, not in February, but in June, have each to be considered in every respect a *dies non*; if either falls on a Sunday, not that day, but the next is to be reckoned as Sunday, which, of course, would occasionally throw Sunday one day, or even two days, ahead of its place in the sequence of seven days.

Now it may safely be affirmed that, not only for its practical inconvenience and disturbance of the uniformity and continuity which are so desirable in a calendar, but for other reasons also, even more weighty, this alteration can never be accepted in Christian countries, nor could it commend itself if we began *de novo*.

As regards the days of the month, the case is different. The existing arrangement was a perversion of that decreed by Julius Cæsar. He ordained that the year should begin with January, the 1st being the day of new moon nearest the winter solstice when the change was made, and that that month should have thirty-one days and each alternate month afterwards, the rest to have thirty, excepting February, which should have twenty-nine days in common years and thirty days in leap-years, to fall every fourth year. In the reign of Augustus, who looked upon August as his special month, though it was not that of his birth, the convenient and easily to be remembered arrangement of Julius was altered in order that August might have as many days as July. By the earlier arrangement the days of the successive months were 31, 29 (or 30), 31, 30, 31, 30, 31, 30, 31, 30, 31, 30; by the later (now followed), 31, 28 (or 29), 31, 30, 31, 30, 31, 30, 31, 30, 31.

No doubt Cæsar placed the leap-day in February because that had been the last month of the year in the old Roman calendar. There would be no harm, if we were starting afresh, in placing it in June as proposed by Mr. Pearce; but it would injure continuity (always a desirable thing in itself) and not attain his object unless the day, as well as New Year's Day, were made a *dies non*, both in the week and in the

month. Neither of these would be convenient; the first is, for other reasons also, inadmissible.

On one point we agree with Mr. Pearce, and that is as regards the incidence of Easter. There is a common, but false, impression that the existing cumbersome arrangement has the authority of the Council of Niceæ. All that that council decreed was, in opposition to the so-called Quartodecimans, that Easter should always be kept on a Sunday; the particular Sunday was regulated by various cycles, the Metonic being usually followed, and the present rule was initiated by the advisers of Pope Gregory XIII., the English Prayer-Book rule arriving at the same end, when our calendar was reformed, by a slightly different process. It has not secured uniformity in Christendom because the Eastern church still follows the Julian calendar, and therefore its Easter is usually different from ours. A rule to keep Easter on the second Sunday in April (when the first Easter in all probability fell) would be very convenient, but it is an ecclesiastical question, and the alteration should be the act of the whole church. To make it always on the same day of the month, as well as week, as Mr. Pearce proposes, could not be done without accepting his other drastic and inadmissible proposals.

W. T. L.

PECULIARITIES IN THE STRUCTURE OF SOME HEAVENLY BODIES.

PROF. SUESS has recently contributed a suggestive paper on peculiarities in the structure of some of the heavenly bodies¹ to the Academy of Sciences of Vienna. He remarks at the outset that the present phase of geology is similar to that of anatomy at the time when the structure of the human body was first compared with that of other living organisms. For the purpose of comparative study it is essential that the earth should be regarded as a whole, and when this is done it becomes fairly obvious that acid rocks and their derivatives, which form so large a portion of the visible surface, are far less important as constituents of the globe than might at first sight be supposed. We see but little of those heavy substances to which the earth owes its high density, and which appear to be more closely associated with the basic than with the acid rocks. Our author considers that for the general purpose which he has in view three main types of rock should be recognised—SiAl rocks (sal or salic rocks), SiMg rocks (sima or simic rocks), and NiFe rocks (nife or nific rocks). For the simic rocks containing chromium and iron he uses the term *crofesima*. The most important occurrences of platinum are in the *crofesimic* rocks, which also contain almost always traces of nickel. These rocks are of deep-seated origin, and it is a significant fact that they frequently occur as intrusions along planes of movement in the younger mountain chains, such as the Alps, e.g. zone of Ivrea.

In 1901 the author, in a letter to Sir Norman Lockyer (*NATURE*, October 24, 1901, p. 629), directed attention to the fact that the metals associated with the basic rocks are not only distinct from those which often accompany the acid rocks, but that they agree closely with those which stand out prominently in the Fraunhofer spectrum and in α Cygni. This led Sir Norman to institute a special research, with the result² that "the views of Prof. Suess were confirmed . . . and that the metals conspicuously represented in the spectra of the sun, the chromosphere, and α Cygni are, in the main, those which are asso-

ciated with basic rocks; also that, with the possible exception of yttrium and lithium, the metals typical of acid rocks are not represented in α Cygni. There is, of course, evidence that several of the acid-rock-metals such as potassium, beryllium, cerium, tin and zirconium are represented in the Fraunhofer spectrum, but the solar lines are in each case inconspicuous."

Commenting on the above quotation, Prof. Suess points out that if the composition of the earth be considered quantitatively there is every reason to believe that it would, if subjected, to the necessary physical conditions, yield a sun in which the basic group of metals would spectroscopically dominate over the acid group.

In considering the distribution of metals of the basic, or, as he now expresses himself, of the simic group, the author directs attention to the local predominance in terrestrial occurrences of certain metals, e.g. titanium over nickel and *vice versa*. Similarly, if γ Cygni be compared with α Cygni, titanium, strontium, and scandium will be seen to be more important, and iron, chromium, and magnesium less important in the former than in the latter.

The special importance of titanium in sun-spots is compared with the predominance of this metal (ilmenite) over nickel in the contents of the diamond-pipes of South Africa, which are regarded as the most striking terrestrial examples of gaseous eruptions.

In the concluding part of the paper the author briefly reviews the theories as to the origin of meteorites, and favours the view that they, together with the planetoids, represent the fragments of an anonymous planet which formerly occupied a position between Mars and Jupiter: "The centre of this planet," he says, "consisted of nife like that of Agram or Elbogen. Towards the exterior the proportion of magnesium increased, and a transition from nife to sima took place, as is probably the case with the earth, although the supposition cannot be verified by observation. A salic outer crust was absent unless it be represented by the perfectly molten tektites."¹

SIR JOHN ELIOT, K.C.I.E., F.R.S.

THE news of the death of Sir John Eliot, K.C.I.E., F.R.S., in his sixty-ninth year, at his residence, Bon Porto, Cavalaire, Var, France, will be received with great regret by a very large circle of friends. His death was extremely sudden, and took place in the early morning of Wednesday, March 18. He was walking on a steep hill in his own grounds, superintending the work of his men, when he suddenly sat down and passed away. The cause of death is said to have been apoplexy.

Sir John Eliot was throughout his life a most indefatigable worker, and since his retirement from the Indian Service about five years ago he had continued to work with unabated vigour. Indeed, the strenuous work which he undertook may perhaps have undermined his health, and have caused his premature death. He was one of the most genial companions possible, having a most charming personality, together with a keen sense of humour. He was most widely read and well informed in almost every subject, and at the same time he was one of the most modest of men. He was a most accomplished musician, and played the organ and piano with very great execution and feeling. He was also

¹ This term has been proposed by Dr. F. E. Suess ("Die Herkunft der Moldavite und verwandter Gläser," *Jahr. geol. Reichsanst.*, 1900, p. 193) for certain peculiar vitreous bodies which he refers to as extra-terrestrial origin.

² *Urs. Mathem.-naturw. Klasse.* Bd. cxvi., October, 1907.
³ Comparison of Metals present in Certain Terrestrial and Celestial Sources. (Solar Physics Committee, 1907.)

greatly loved and esteemed by his subordinates and fellow-workers, and by his many friends.

Sir John Eliot had a most distinguished career, and the major part of his life was devoted to India, at first to educational work, and later on to Indian meteorological problems. He was born at Lamesby, in Durham, on May 25, 1839. The details of his earlier education have not been recorded, but he went up to Cambridge University about 1866 and took his degree from St. John's College in 1869, and was second (bracketed) wrangler and first Smith's prizeman of his year. He was then elected to a fellowship at St. John's College, which he held from 1869 up to his marriage in 1876. As a young man his health was not very robust, and he was advised to avoid the climate of England, so that after taking his degree he accepted an appointment in the Indian Government Service as professor of mathematics at the Roorkee Engineering College. This he held from 1869 to 1872. He was then transferred to the regular Indian Educational Service as professor of mathematics at the Muir Central College at Allahabad, an appointment which he held from 1872 to 1874.

About this time he turned his special attention to physics rather than to pure mathematics, and also undertook certain meteorological work at Allahabad. In 1874 he was appointed professor of physical science at the Presidency College, Calcutta, and combined this with the post of meteorological reporter to the Government of Bengal, both of which he held from 1874 to 1886. He was then appointed meteorological reporter to the Government of India and director general of Indian observatories, an appointment which he held until he retired in January, 1903. On his retirement the Government of India published in the *Gazette of India* a most complimentary resolution thanking him for "his long and meritorious services."

As an educationist he has left his mark in the various colleges in India in which he worked, and also in the Calcutta University, of which he was for many years a most distinguished Fellow. Many of the present generation of educated Indian gentlemen who are holding very prominent positions are largely indebted to Sir John Eliot, not only for his actual teaching, which was of a particularly high order, but also for his kindness and sympathy towards his students. The example shown by his work and character had a great effect on all brought in contact with him, and he was very greatly respected and loved by his students and by all classes of Indian gentlemen, for it may be truly said of him that his great abilities were more than equalled by his extreme modesty and invariable kindness.

In his capacity as Fellow of the Calcutta University he also did very notable work, and by his great influence and marked powers of persuasion he was able to introduce many considerable reforms into the courses of instruction in mathematics and physical science, and in the latter case he was specially successful in making the courses more practical and more thorough than they had hitherto been.

As a meteorologist, India also owes him a large debt of gratitude. As meteorological reporter to the Government of Bengal, he largely extended the meteorological system, and introduced daily weather reports with charts based on telegraphic information, and he also instituted a very comprehensive and effective system of storm warnings for coast stations round the Bay of Bengal, and of flood warnings for inland stations. One of his earliest meteorological papers was a "History of the Backergunge Cyclone of 1876," in which storm about two hundred thousand people were drowned in about half an hour by a huge storm wave, which swept over the Island of Sandip.

In this monograph Sir John Eliot largely developed and extended the theory of the formation of cyclones. This publication indeed excited a good deal of attention both in India and in England, and in both instances this was unusual. So much attention was directed to this memoir and to the cyclone which it described that a request was made in the House of Commons for the report to be produced and laid on the table, and it was then made available to those interested in England.

The reputation as a meteorologist which Sir John Eliot gained while occupying the post of meteorological reporter to the Government of Bengal rendered it a foregone conclusion that when the higher post of meteorological reporter to the Government of India fell vacant it would be offered to him. This post had been created about the year 1875 or 1876, and its first incumbent was the late Mr. H. F. Blanford, F.R.S. Up to about 1875 there had only been local officers in charge of the meteorology of the different provinces (such as Bengal, Madras, and Bombay) into which India is divided, but it was felt that if Indian meteorology was to make any real progress it must be studied as a whole, and not piecemeal. Hence the appointment of meteorological reporter under the Imperial or Indian Government was created, and all the observations taken in the various provinces were, after local use, sent on to the Indian Meteorological Department. Much and most valuable work was done by Mr. Blanford in the development of the department on an Imperial basis, and also in the foundation of systematic and organised investigation and in the prompt diffusion of meteorological information thus obtained, but, as in all great schemes, the progress of consolidation of the work in its imperial aspects was rather difficult.

With Mr. Blanford's work as a basis, Sir John (then, of course, Mr.) Eliot was able to make more rapid progress. He largely increased the area from which observations were received, and also the number of reporting stations in the area already covered. Indeed, during his tenure of office he almost doubled the number of stations which sent in reports, and extended them so as to get observations from very high altitudes (11,000 feet elevation), and also from outlying places like Kashmir and the routes leading towards Central Asia, and from such places as Leh, Ladakh, Dras, &c. He made the work of the observatories more accurate and more systematic, and arranged that by telegraphic communication the latest meteorological information from all parts of the Indian Empire in the form of daily weather reports with charts should be at once available at headquarters.

Indeed, it is not too much to say that from the time he took over charge of the Indian Meteorological Department, its efficiency and usefulness were very largely increased, and that he brought it quite into line with the most modern meteorological organisations. Under him the department published many series of most valuable results and memoirs. He also developed a complete system of storm warnings for the whole of the coast-line of India and Burma, extending over some thousands of miles, and also established flood warnings for the whole of India by which telegraphic warnings are sent of expected floods to all engineers in charge of irrigation and other large works, and in other cases where similar damage may occur. Daily reports with charts dealing with the sea areas of the Bay of Bengal and Indian Ocean were also established, and, further, he established a most valuable system of seasonal forecasts, which gradually became of very great value, though naturally to begin with they were rather tentative and experimental.

Those who navigate Indian seas are also especially

indebted to Sir John Eliot for his work, "Handbook of Cyclonic Storms in the Bay of Bengal," which has in all human probability been the means of saving many vessels and valuable property—possibly from destruction and certainly from damage—by enabling such vessels, by the rules laid down in that work, to avoid the more dangerous parts of these cyclones, and also generally to escape from them altogether by the knowledge thus given of the indications of the approach of such storms and of the tracks usually followed by them in the different months of the year.

Indeed, it would be an easy matter to prove that in many instances the information and warnings conveyed from the Indian Meteorological Department have been the means of helping that Government and individuals in a most remarkable manner, and that even to put the matter on the lowest ground, it has saved the State vast sums of money by giving accurate information of the precise meteorological conditions of the country, and timely warnings of possible famines, and in some cases, when famine seemed looming in the immediate future, of timely information of approaching rainfall, which at once would do away with the necessity of starting famine relief operations on a large scale. The Indian Meteorological Department has far more than justified its existence, for it has really proved itself of far greater value than its relatively small cost.

Sir John Eliot was also very greatly interested in the subject of solar physics, and he was largely instrumental in starting the solar physics observatory at Kodaikanal, in southern India, and immediately on his retirement he was appointed as a member of the Solar Physics Committee, and also on other scientific bodies, and he worked quite as hard as he had always done in India. Indeed, he was at work up to the last, for on the Monday before his death he was engaged on his new book, "A Handbook of Indian Meteorology," and said he was making great progress with it.

One who knows well the work of Sir John Eliot after his return to Europe writes as follows:—

"Sir John Eliot left India full of enthusiasm for the future of his department. As a public servant he had the rare satisfaction of knowing that a scientific enterprise begun with some doubt and misgiving, had, under his direction, established its claim to a recognised position, and had justified the anticipations of its promoters. His last official step was to secure for his successor the increase of the scientific staff of which he had himself felt the need.

"On his return to England he gave expression to his experience and his aspirations in an address to the British Association at Cambridge in 1904 as president of the subsection for astronomy and cosmical physics. Reviewing his own work and stimulated by his success, he looked beyond the forecasts of to-morrow's weather to anticipating, on strictly scientific grounds, the character of the seasons by the correlation of meteorological phenomena over extended regions of the earth and their possible relation with solar changes. He became secretary of the Solar Commission, originated upon the proposition of Sir Norman Lockyer by the International Meteorological Committee, which met at Southport in 1903. The purpose of the committee was to collect comparable meteorological data from all parts of the world and solar data for comparison with them. He spent a considerable part of his last stay in England in planning new arrangements for carrying out the objects of the Commission. In the latter part of his address at Cambridge he advocated the organisation of the British contribution to this side of meteorological work upon an imperial basis. He realised that an imperial combination would treat such questions with a breadth of view that is

not possible or permissible in any single colony or dependency, guided, as it must be, by the narrower consideration of its immediate needs.

"His plan was to provide for organised observations from areas too wide to be within the control of any single Government; to place the material thus obtained at the service of workers in all parts of the world by publishing it while it was still of direct practical utility and to ensure its application to the service of the Empire by a special staff of trained workers.

"Anyone who reads the address cannot fail to catch something of his enthusiasm. There is a ring of the 'land of hope and glory' about his appeal for the extension of our knowledge of the facts. 'Wider still and wider be thy boundaries set' bespeaks the ideal of his meteorological method, and it was to the various parts of the King's dominions that he looked for its realisation. The task was no light one. The British Association made a beginning, but imperial wheels grind very slowly. It says much for Eliot and for India that he carried with him the active support of the Indian Government for the proposal. He welcomed the idea of a meeting of British meteorologists in Canada, because it gave him the opportunity of getting a step forward, and although conscious of the personal sacrifice which it involved, he undertook to make the journey to Ottawa this year for the purpose. The intention cannot be fulfilled."

"It is a bitter disappointment to all his fellow-workers that death has brought his efforts to an untimely end. His enthusiasm was entirely free from any suggestion of selfishness or personal ambition; he could speak from an unique position with unrivalled experience. There is no one now to take his place. But the idea remains, and this country seldom wants for men when there is real work to be done. Remembering Eliot's achievements we are emboldened to fall back upon the refrain, and to add the second couplet without misgiving:

Among the more prominent of Sir John Eliot's publications are numerous accounts of cyclones and severe cyclonic storms occurring within Indian seas; also numerous meteorological discussions contributed to the Indian Meteorological Memoirs, to the Indian Cyclone Memoirs, to the Journal of the Asiatic Society of Bengal, and to the Quarterly Journal of the Royal Meteorological Society; his "Handbook of Cyclonic Storms in the Bay of Bengal" (already mentioned), and his last publication, which took the form of that most valuable work, "The Climatological Atlas of India," published by the authority of the Government of India only a few months ago; while at the time of his death he was engaged in writing a "Handbook of Indian Meteorology" to accompany this, also to be published under the direction of the Government of India.

Sir John Eliot was elected a Fellow of the Royal Society in 1895; he was created a C.I.E. in 1897, and was given his K.C.I.E. in 1903 on his retirement. In 1877 he married Mary, daughter of Mr. Wm. Nevill, of Godalming; his widow survives him, and he has left three sons. A. P.

NOTES.

SIR OLIVER LODGE was unable to deliver his presidential address to the Faraday Society on Tuesday on account of an attack of influenza, from which, however, he is now recovering.

We regret to state that the Duke of Devonshire died at Cannes on Tuesday morning, at seventy-four years of age. The Duke was a Fellow of the Royal Society and Chancellor of the University of Cambridge.

THE Right Hon. A. J. Balfour, F.R.S., has been elected a corresponding member of the French Academy of Moral and Political Sciences in succession to Lord Reay, who has been elected an associate.

THE Paris Academy of Sciences has accepted a legacy of 400*l.* from M. Sabatier to found a biennial prize to be known as the Sabatier prize.

ON the drill ground at Issy-les-Moulineaux on Friday, March 20, Mr. H. Farman traversed the complete circle two and a half times with his aeroplane, the length of the flight being 2750 yards, and the time 2*m.* 15*s.*

WITH regard to the inquiry of a correspondent (NATURE, March 5, p. 417) for particulars concerning the mist and Sicilian earthquake of 1783, Mr. E. A. Martin, The Museum, Croydon, writes to point out that Gilbert White has a reference thereto in his Letter 65 to Barrington ("Natural History of Selborne").

DR. HALL-EDWARDS, who recently had his left hand amputated in consequence of X-ray dermatitis, has been granted a Civil List pension of 120*l.* a year. When Dr. Hall-Edwards has recovered from the effects of the amputation, another operation will be necessary, and at least four fingers of his right hand will have to be amputated.

ON Thursday next, April 2, Mr. R. Lydekker will begin a course of two lectures at the Royal Institution on (1) "The Animals of Africa," (2) "The Animals of South America." The Friday evening discourse on April 3 will be delivered by the Right Hon. Lord Montagu of Beaulieu on "The Modern Motor-car," and on April 10 by Prof. J. J. Thomson on "The Carriers of Positive Electricity."

THE death is announced, in his seventieth year, of Dr. D. B. St. John Roosa, president of the New York Medical Post-graduate School, and professor of diseases of the eye in that institution. He formerly held chairs in the University of the City of New York and the University of Vermont. He was the author of a pocket medical lexicon and of various treatises on the eye and the ear.

PROF. W. A. KELLERMAN, who has held the professorship of botany at the Ohio State University since 1891, has died of malaria in Guatemala, which country he was visiting in order to study its flora. He was born in 1850, graduated at Cornell in 1874, and had taught botany at the Wisconsin State Normal School and the Kansas State Agricultural College. He was perhaps most widely known as founder and editor of the *Journal of Mycology*. Among his books were "Flora of Kansas," "Spring Flora of Ohio," and "Phyto-Theca."

REFERRING to the article on "Some London Problems" published in our issue of March 19, a correspondent directs attention to the arrangement for the construction of deep-water wharves near Gravesend, in Long Reach, about five miles above Tilbury. These wharves have been licensed by the Thames Conservancy and approved by the Board of Trade, though their construction has been delayed because of the Port Bill. This wharf will be capable, our correspondent states, of dealing with three million tons of traffic a year.

THE Royal Commission on Coast Erosion has been directed to inquire whether, in connection with reclaimed lands or otherwise, it is desirable to make an experiment in afforestation as a means of increasing employment during periods of depression in the labour market, and, if so, by

what authority and under what conditions such experiment should be conducted. The following new members have been added to the commission:—Mr. J. Galvin; Mr. E. S. Howard, C.B., Mr. H. C. Monro, C.B., Dr. W. Somerville, Mr. F. Story, and Mr. J. Ward, M.P.

THE sixty-first annual meeting of the Palaeontographical Society was held on March 20 in the rooms of the Geological Society, Burlington House, Dr. Henry Woodward, F.R.S., president, in the chair. The annual report alluded to the unusually varied contents of the volume for 1907, due to an attempt to provide indexes and title-pages for several monographs which were either complete or discontinued. The council is beginning to favour the plan of publishing smaller works, and has included in the current volume a complete monograph of British Conulariæ, by Miss Ida L. Slater, with five plates drawn by the author. The council welcomed a contribution from the Carnegie Trust for the Universities of Scotland, which provided five plates of Scottish Carboniferous fishes described by Dr. Traquair. Mrs. G. B. Longstaff, Mr. H. A. Allen, Dr. F. A. Bather, and Mr. William Hill were elected new members of council. Dr. Henry Woodward, F.R.S., Dr. G. J. Hinde, F.R.S., and Dr. A. Smith Woodward, F.R.S., were re-elected president, treasurer, and secretary respectively.

NO. 3 of the 1908 issue of the Bulletin of the Imperial Academy of St. Petersburg contains an elaborate and well-illustrated account of the developmental history of the echinoderm *Echirus*, by Dr. N. Salensky.

THE third part of vol. vii. of the *Emu*—issued as a special supplement—is devoted to a list of Australian birds on the model of the one now in course of issue by the British Museum. The compiler, Mr. G. M. Mathews, who has recently come to reside in this country, announces his intention of issuing an illustrated work on the birds of Australia, to which the present "hand-list" is a preliminary.

RECENT issues of the Proceedings of the U.S. National Museum include papers by Mr. A. H. Clark on the crinoid genus *Comatula* (No. 1585), and on the occurrence of infrabasal in certain modern pentacrinids (No. 1582), as well as one (No. 1580) by Mr. C. B. Wilson on North American parasitic copepod crustaceans, and another (No. 1586) by Miss Richardson on isopods from the northern Pacific.

IN an article published in the *National Geographic Magazine* for February under the title of "The Policemen of the Air," Mr. H. W. Henshaw raises the question as to what would happen if birds were completely exterminated. "No one," he observes, "can foretell with absolute certainty, but it is more than likely—nay, it is almost certain—that within a limited time not only would successful agriculture become impossible, but the destruction of the greater part of vegetation would follow. It is believed that a permanent reduction in the numbers of our birds, even if no species are actually exterminated, will inevitably be followed by disastrous consequences." It is added that bird-protection in the United States requires specially stringent laws on account of the large influx of immigrants from southern Europe, to whom every bird, no matter how small, is regarded as food which ought not to be wasted.

A FURTHER contribution to the controversy with regard to the alleged existence of a British willow-titmouse (*Parus atricapillus kleinschmidti*) is made by Mr. H. B. Booth in the March number of the *Naturalist*. It has been stated

that the principal differences between willow-titmouse and marsh-titmouse are that the feathers on the crown and forehead are longer and more loosely constructed in the former than in the latter. The edges of these feathers are also glossy black in the marsh-titmouse, thus causing the crown to be glossy and of a deeper blackness than that of the willow-titmouse, which is brownish or sooty black. In the latter, again, the tail is distinctly graduated, instead of being almost squared. To these differences Mr. Booth adds the darker rufous colour of the flanks and underparts of the willow-titmouse.

The evolution of the elephant forms the subject of an interesting article by Mr. R. S. Lull, in the March number of the *American Naturalist*. Starting with the fact that they made their first appearance in the Fayum district of Egypt during the Eocene, the author considers it probable that the proboscideans remained in Africa during the Oligocene, although we have no direct evidence to that effect. Be this as it may, the four-tusked mastodon (*Tetrabelodon angustidens*) made its appearance in the early Miocene of Mogara and Tunisia, whence it migrated by means of a land-bridge connecting Tunisia and Sicily with Italy, and thence by way of Greece, into Asia. Having reached that continent, it apparently gave rise to the Indian *Mastodon cantleyi* and *M. latidens*, from which in turn sprang the primitive, or stegodont, elephants, and from these again elephants of the modern type. Later on the typical elephants themselves migrated westwards to Europe, and thence to Africa, while in the other direction they travelled by way of Bering Strait to America. Hence we are led to conclude, as has been previously pointed out by Mr. Lydekker, that while the Proboscidea originated in Africa, the modern African elephant is of Asiatic parentage, and was an immigrant into the land of its forefathers in company with the ancestors of the giraffes, okapis, and antelopes which now dominate Ethiopia. It is added that, next to man, elephants have been the greatest travellers of all mammals, having reached practically all parts of the world.

UNDER the heading of "Investigations on the Development of Trypanosomes in Tsetse-flies and other Diptera," Prof. E. A. Minchin gives in the March number of the *Quarterly Journal of Microscopical Science* the results of his investigations during a sojourn in Uganda as a member of the commission on sleeping sickness. In the author's opinion, it may now be admitted that trypanosomes undergo development (as distinct from multiplication) in invertebrate hosts, more especially tsetse-flies. It is, however, remarkable that, whereas *Trypanosoma brucei* undergoes a complete cycle of development in at least one kind of tsetse, this is not the case with *T. gambiense*. The explanation suggested is that *Glossina palpalis*, the only kind of tsetse found at Entebbe, is not the proper host of *T. gambiense*, a suggestion supported by the fact that sleeping sickness is a disease of comparatively recent introduction into Uganda. That the Gambian trypanosome has a proper host of its own cannot be doubted, and it is probable this may be a native of the Congo, where it is suggested further investigations on sleeping sickness might advantageously be conducted. In Uganda *T. gambiense* merely commences its developmental cycle in *G. palpalis*, by which, in that district, it is transmitted to the human subject in a purely mechanical and direct

may be obtained for microscopical work. For observation, medium and high-power dry objectives should be employed. The apparatus is particularly adapted for the observation of such minute objects as bacteria and their flagella, spirochaetes, &c., in the fresh and living state, and for photographing the same under these conditions. We have also received Messrs. Zeiss's general catalogue of apparatus for ultramicroscopy, which contains much matter of interest.

In the *Journal of Hygiene* for January (vol. viii., No. 1) Miss Harriette Chick contributes an interesting article on the theory of disinfection. She shows that a very complete analogy exists between a chemical reaction and the process of disinfection, one reagent being represented by the disinfectant, and the second by the protoplasm of the bacterium. In the case of anthrax spores, the course of disinfection apparently proceeds in accordance with the well-known equation for a unimolecular reaction, if numbers expressing "concentration of reacting substance" are replaced by "numbers of surviving bacteria." A non-spore-forming organism, *B. paratyphosus*, shows a departure from the simple law owing to permanent differences in resistance to disinfectants among the individual organisms, the younger bacteria proving to be the more resistant. The process of disinfection is influenced by temperature in an orderly manner, and the well-known equation of Arrhenius can be applied. Some evidence was obtained that, in disinfection with mercuric chloride, a toxic compound is formed between the metal and the substance of the bacterial cell.

THE principal article in the *Bulletin du Jardin Impérial Botanique* of St. Petersburg (vol. vii., parts v.-vi.) is an account of the soil and vegetation of the district of Jaïla, in the Crimea, communicated by Mr. A. Krischtowitsch.

TAMARIND seeds are to be reckoned among the fairly nutritious plant products that have been reported to provide food during periods of famine in India. The pulp of the fruit is an esteemed ingredient of certain condiments. The kernels of the seeds when freed from the skin and roasted furnish a not unwholesome flour suitable for mixing with cereals to make small cakes. Further details and analyses are given in the *Agricultural Ledger* (No. 2, 1907) prepared by Mr. D. Hooper and published by the Government of India.

THE annual publication "One and All Gardening" has reached its thirteenth issue. Among the numerous articles, Mr. H. J. Wright furnishes an account of garden-teaching in schools, in which he provides a working plan for laying out a school garden, and summarises the progress made in different counties. Mr. S. L. Bastin contributes a note on the method of retarding flowers. The editor takes for his subject the formation of garden associations to stimulate horticulture in country and town; in this connection Mr. F. H. Stead records a remarkable development of gardens in the borough of Walworth, where last year more than one hundred gardens were entered for competition at the local flower show.

THE fauna and flora of the Snares and Auckland Islands form the subject of an ecological descriptive sketch contributed by Dr. L. Cockayne to the *New Zealand Times* (December 11, 1907). The author refers to the evidence furnished by the animal and plant life on the Snares in favour of the view that when a land area is curtailed the exceptional species most frequently survive in the struggle for existence, and so reduced areas generally contain numerous endemic species. The meadows of the

received from Messrs. Zeiss a pamphlet describing the Sidentopf's paraboloid condenser, with which an exceedingly well corrected dark ground illumination

Auckland Isles furnish numerous choice plants, notably the species of the composite genus *Pleurophyllum*, *Myosotis capitata*, a *Celmisia*, and gentians. Characteristic plant associations on the islands are the tussock-grasses, *Poa scoparia*, *Poa foliosa*, and *Danthonia bromoides*, confined to special localities determined chiefly by wind conditions.

The preservation of plants so as to maintain their green colour has been attempted in several ways. Prof. Trail some years ago recommended the use of a solution of acetate of copper in acetic acid, whereby compounds of chlorophyll with copper are formed. He contributes a note to the *Kew Bulletin* (No. 2) to point out the advantage of using a boiling solution. In the same number an article on Jequié maniocaba refers to the occurrence in north-east Brazil of rubber trees allied to *Manihot Glaziovii*, the source of Ceara rubber. According to German botanists, three other species, *dichotoma*, *heptaphylla*, and *piauhyensis*, should be distinguished; they are named after the regions in which they grow as Jequié, S. Francisco, and Piauhy maniocabas; all are considered to be more valuable than *Manihot Glaziovii*. Determinations of new plants are published as "Diagnoses Africanæ, XXI.," and "New Orchids, XXXI." The identification and occurrence of different patchouli plants form the subject of another article, and Mr. A. D. Cotton discusses the appearance in Great Britain of the alga *Colpomenia sinuosa*, indigenous in the Mediterranean.

The report of the Chief Inspector of Mines of Mysore for the year 1905-6 (Madras, 1908) is devoted chiefly to official data on the progress of the Kolar gold mines. A decline in production is noticeable, due mainly to the decline in grade of the ore milled. There was also noticeable an increased death-rate from accidents in 1905, due mainly to a serious underground fire at the Nundydroog mine. The total value of gold bullion produced from the commencement of mining operations in Mysore up to the end of 1905 was 23,384,532*l*.

The Geological Survey of Great Britain issued two additional west-country memoirs at the close of 1907. Mr. Clement Reid's "Geology of the Country around Mevagissey" (price 2*s.*) illustrates Sheet 353, which includes also the geinissic islet of the Eddystone from Sheet 354. This relic is probably part of an Archæan mass running east-north-east, which has governed the trend of the earth-folds in the Mevagissey district. The memoir points out how the Silurian rocks, coloured as "Grauwacke" in the old map of 1839, have now been delineated in some detail; but volunteers are asked for who will elucidate the difficulties still remaining. Beautiful examples of shear-structure in banded slates are given in the photographic plates. The second memoir is by Mr. Ussher, in explanation of Sheet 348, on "The Geology of the Country around Plymouth and Liskeard" (price 3*s.*), and forms a very notable contribution to our knowledge of British Devonian strata. Dr. Flett describes the numerous volcanic and intrusive rocks occurring here on various horizons. An unconformity is suggested between the Lower and Middle Culm-measures, to account for the occurrence of both series directly on Upper Devonian beds in the northern portion of the map. Mr. Ussher believes that the submerged valleys cut in the rock on the south coast owe most of their depth to river-erosion during the epoch of elevation that gave us the raised beach of the district. When this beach, therefore, was being formed at sea-level, these valleys ended in merely shallow tidal inlets. This conclusion is, as Mr. Ussher points out, in opposition to views put forward for similar phenomena in

the south of Ireland. Mr. D. A. Macalister contributes a report on the mines and minerals of the district. The colour-printed maps accompanying the memoirs above mentioned are published at 1*s. 6d.* each, and include, as usual, clear longitudinal sections of the country in the margins.

ACCORDING to a report in the Proceedings of the Philadelphia Academy for December, 1907, the glaciers of Alberta and British Columbia are passing through a period of shrinkage, which attained special development during the year under review. The Asulkan glacier, for example, which for several years was stationary or slightly advancing, showed a marked decrease during the past season. "Preceded by a cold and stormy winter and a summer with low average of sunshine and low temperature, these conditions point to an interesting series of changes which may ultimately throw some light on the relation between weather conditions and glacier change."

THE Scottish Oceanographic Laboratory at Edinburgh has recently issued, in the shape of a small pamphlet, an account by Dr. J. Hjort, of Bergen, of some of the results of modern international oceanic research. The account, which is translated from the Norwegian, deals firstly with the new methods of current-measurement, and then with the life-history and development of several of the commoner food-fishes, such as haddock, herring, saith, cod, and plaice. Diagrammatic illustrations are given of the form and size of the scales of these fishes at different periods of existence, and the means of thereby ascertaining the approximate age of any individual fish. The ages of the plaice are illustrated, on the other hand, by diagrammatic sketches to scale of four specimens at as many stages of existence. The pamphlet should be of considerable value to all who are connected with our fisheries.

A DETAILED account by Mr. A. Schmauss of twenty-one unmanned balloon ascents made in 1907 at Munich is published in an excerpt paper from the regular meteorological year-book of Bavaria. The experiments, which were made with great care, show that in the lower air strata the temperature gradient is subject to great oscillations, and that the greatest decrease of temperature with height is found between 5 and 8 kilometres. Between 8 and 11 kilometres there is a transitional zone leading to the upper isothermal layer or inversion. After this stratum of increasing temperature follows another slowly augmenting decrease of temperature from about 14 kilometres upwards. Between 1 and 5 kilometres the same rate of decrease of temperature that exists at mountain stations was found to hold good.

In the *U.S. Monthly Weather Review* for October, 1907, Mr. H. H. Clayton (by permission of Prof. A. L. Rotch) discusses the lagging of temperature changes at great heights behind those at the earth's surface, and types of pressure changes at different levels, as shown by the records of sounding balloons liberated at St. Louis in April and May, 1906. The observations show that at all heights above about 1 kilometre the temperature changes occur later with increasing elevation; at 10 kilometres the maxima and minima are generally about twenty-four hours later than on the ground. Only a few observations at 15 kilometres were available, but they appear to show that the irregular ranges of temperature at that height are much less than at sea-level. Referring to the maxima and minima of pressure, it is found that at 10 kilometres the curve is almost the reverse of that at sea-level; at 15 kilometres it is somewhat similar to that at 10 kilometres, but the ranges are much reduced.

Among other useful articles we may mention Mr. W. A. Bentley's interesting studies of frost and ice crystals, and a mathematical investigation by Prof. F. H. Bigelow on vortices in the atmosphere.

Tidal bores in China and Japan form the subject of two recent papers differing widely in character. In the *Popular Science Monthly* for March Dr. Charles Keyser Edmunds gives an illustrated account of his visit to the Hangchow bore, while a bore in Odawara which sometimes does much destruction is treated, from the hydrodynamical point of view by Prof. H. Nagaoka in a short note in the Proceedings of the Tokyo Mathematico-Physical Society for November last.

THE Bulletin of the American Mathematical Society for March contains an account of a joint meeting held at Chicago in December last between mathematicians and engineers for the discussion of the teaching of mathematics to engineering students. The discussion in question refers mainly to the mathematical requirements of the average engineer who is occupied exclusively in practical applications of known methods. Little or nothing is said by the speakers about the growing need of original workers, who, by bringing the highest mathematical knowledge to bear on engineering problems, are able to devise new methods, and to guide the ordinary practical experimenter.

A SUGGESTION for a new economic arithmetic is the subject of a short paper in the *Economic Journal* for March by Prof. T. N. Carver. The author's ideas are simple and practical, and at the same time scientific. He considers that the teaching of arithmetic can be illustrated with advantage by simple problems based on tables, of which he gives as an example one showing the quantity of corn grown with varying quantities of labour on a given quantity of land. The problems that can be worked out as exercises with such a table include the following:—Given the cost of labour and the value of the corn, how many days' labour can be most profitably devoted to the cultivation of the fields? Or, again, given the number of available days' labour, how many acres can be most profitably cultivated? It is pointed out that complicated mathematical methods or the plotting of curves are unnecessary for the solution of such simple problems, and the author quotes the existing methods of dealing with tariff reform controversy as an instance of the want of such simple training. In support of the author's view, it must be admitted that there is a great deal commonly taught under "arithmetic" which might well be superseded by such studies as he suggests. But where are the statistics necessary for such a course to be obtained?

THE *National Geographic Magazine* (xix., 1) contains an illustrated account of Dr. Alexander Graham Bell's experiments with his *Cygnets* man-lifting kite. This kite was sent up in December, 1907, both with and without a man, Lieut. Selfridge having ascended 168 feet with it, and having remained in the air for more than seven minutes. The kite is described as "tetrahedral" in shape—perhaps it would be better to describe it as a triangular prism with oblique ends. It measures 13 metres laterally at the top and 10 metres at the bottom, 3 metres longitudinally at the bottom, and 3 metres in oblique height. It consists of 3393 winged cells having a surface of 1830 square metres. It weighs 85 kilograms, and is furnished with floats, weighing 9.4 kilograms, which enable it to rest on the surface of a sheet of water. In the experiments performed at Baldeck, Nova Scotia, the kite flew with remarkable steadiness, and Dr. Bell considers

this fact a justification for extending the experiments to motor-driven machines constructed on a similar principle.

AN interesting lecture was given by Sir William Preece at the Institution of Electrical Engineers on March 12 on his recent visit to America, and the various improvements in constructional and engineering work since his previous visits were dealt with. The sky-scraper buildings appear to afford a considerable day load in that they employ numerous lifts which are constantly in use, but the public supply does not benefit from these very much, as in the larger buildings the tendency is to erect private plants. On the telephone question, America seems to have gone ahead of us on this side. In most of the hotels telephones are installed in every bedroom, so that business may be transacted with any part of the country. This applies also to the restaurants, where telephones may be plugged on to your table if desired. The Telephone Tariff question has also been thoroughly considered in America, and the message rate has been adopted in preference to the simple annual rental.

IN THE Proceedings of the American Academy of Arts and Sciences (vol. xliii., No. 12) Messrs. Gregory P. Baxter and John H. Wilson describe a number of re-determinations of the atomic weight of lead, the true value of which is at present uncertain owing to the wide discrepancies in the results of previous workers. The method of analysis adopted consisted in determining the proportion of chlorine in lead chloride by precipitation with silver nitrate; this method seemed the best to use in view of the fact that the halogen can be determined with great accuracy, and the elimination of moisture from lead chloride is easily effected by fusion of the salt in a current of hydrogen chloride. Silver chloride, moreover, when precipitated from a dilute solution of lead chloride, does not contain an amount of occluded lead salt large enough to be detected. Special care was taken, of course, in the purification of the materials employed. The results obtained were very concordant, varying in one series, in which the ratio $PbCl_2 : 2AgCl$ was determined, from 207.173 to 207.202, with an average of 207.188; in another series, based on the ratio $PbCl_2 : 2AgCl$, the average 207.191 was obtained, with a range of variation from 207.181 to 207.204. The mean result, $Pb = 207.19$ ($O = 16$, $Ag = 107.93$), is nearly three-tenths of a unit higher than the value for the atomic weight of lead now in use.

A SECOND edition of Mr. J. W. Hayward's "First Stage Steam" has been published by Mr. W. B. Clive.

THE spring list of the Oxford University Press includes "Floral Mechanism" (part i., types 1 to 12), by Dr. A. H. Church, and "Lectures on Evolution," by Prof. E. B. Poulton, F.R.S.

MESSRS. A. GALLENKAMP AND CO., LTD., have issued a catalogue of the Meker hot-flame burners, Dennstedt's combustion furnaces, accessories for use with the furnaces, and cylinders of compressed air, which they are now prepared to supply.

A NINTH edition of Mr. W. T. Lynn's "Remarkable Eclipses" has been issued by Messrs. S. Bagster and Sons, Ltd. The booklet has been brought up to date, and provides a sketch of interesting facts connected with solar and lunar eclipses.

MESSRS. A. AND C. BLACK will publish shortly a book on "Kafir Socialism," by Mr. Dudley Kidd; a book on botany for young children, by Mr. O. V. Darbishire, of Manchester University; and a re-issue, at a popular price, of

the fourth edition of the late Miss Agnes M. Clerke's "History of Astronomy in the Nineteenth Century."

THE Bibliographischen Institut of Leipzig and Vienna has sent us the first part of a second revised and enlarged edition of Dr. M. W. Meyer's popular work on general astronomy entitled "Das Weltgebäude." The edition will be completed in fourteen parts, to be published at the price of one mark each.

It is announced that papers on parasitology, which have hitherto appeared in the *Journal of Hygiene*, will in the future be published in a separate volume to be entitled *Parasitology, a Supplement to the Journal of Hygiene*. The publication will be edited by Prof. Nuttall and Mr. Shipley.

A THIRD edition of Mr. Douglas English's "Wee Tim'rous Beasties" has been published by Messrs. Cassell and Co., Ltd. These studies of animal life and character were reviewed in the issue of *NATURE* for December 24, 1903 (vol. lxi., p. 176), on which occasion we reproduced one of the excellent illustrations with which the volume is plentifully supplied.

WE have received a copy of an interesting and fairly complete international catalogue of the more important periodical publications of the world, which has been compiled by Prof. Émile Guarini, and published in Paris by MM. H. Dunod and E. Pinat. The price is 3 francs, and the catalogue gives the address, publisher, and price of 4063 reviews and journals classified according to countries.

MESSRS. PAWSON AND BRAILSFORD, of Sheffield, have published a third edition of Mr. J. Simpson's "The Wild Rabbit in a New Aspect, or Rabbit Warrens combined with Poultry Farming and Fruit Culture." The book has been revised and enlarged, contains several illustrations, and will probably assist the encouragement of rabbit warrens and rabbit farming, whether conducted for sport or profit.

ANOTHER volume has been added to the series dealing with the fauna of British India, including Ceylon and Burma, edited by Lieut.-Colonel C. T. Bingham, and published under the authority of the Secretary of State for India by Messrs. Taylor and Francis. The new volume continues the consideration of the Coleoptera, and is concerned with a portion of the family Chrysomelidae. It is the work of the late Mr. Martin Jacoby. In a short preface the editor expresses the hope that the book will direct the attention of collectors in India to this somewhat neglected but important group of phytophagous beetles, and prove of assistance to them in their study.

OUR ASTRONOMICAL COLUMN.

WATER VAPOUR IN THE MARTIAN ATMOSPHERE.—A glance at a print from a series of spectrograms taken by Mr. Slipher on January 15, which Prof. Lowell has kindly sent to Sir Norman Lockyer, leaves but little doubt that water vapour is present in the atmosphere of Mars. This print includes two spectra of the moon and one of Mars, and whilst the α band is absent from the former, it is quite a marked feature of the latter spectrum. The exposure for the spectrum of Mars was from 5h. 35m. to 8h. 30m., the mean altitude of the planet being 43° , whilst those for the moon were made at 15h. 26m., the altitude being 30° ; the aqueous vapour per cubic foot of air, during the exposures, was found to be 1.25 grains.

THE DISPERSION OF LIGHT IN INTERSTELLAR SPACE.—In No. 6 (February 10, p. 266) of the *Comptes rendus* Dr. C. Nordmann described a method whereby the dispersion of light in interstellar space might possibly be determined. Briefly, the method consists in making photometric observa-

tions of quickly changing variable stars, the light of the star, being first passed through different coloured screens for each observation. If all radiations traverse space with equal velocities, such observations should give light-curves agreeing in phase among themselves and with those determined in the ordinary method; but if some radiations are relatively retarded, then the light-curves so determined should exhibit marked deviations of phase. Three liquid screens transmitting only radiations of $\lambda\lambda=5000$ to the extreme red, 5900 to 4900 and 4900 to the ultra-violet, respectively, were prepared, and Dr. Nordmann's preliminary results are published in No. 8 (February 24, p. 383) of the *Comptes rendus*.

Algol and λ Tauri were the stars examined, and in both cases it was found that, whilst the light-curves obtained when the several screens were successively employed agree in amplitude and form with the ordinary light-curves, there is a measurable difference in the epoch of any specific phase. With Algol the difference in time for the red and blue screens amounted to sixteen minutes, whilst for the red and green screens the difference was nine minutes; these preliminary values are probably correct to within about three minutes. The difference between red and blue for λ Tauri was about forty to sixty minutes, i.e. approximately three times the analogous difference in the case of Algol; that is to say, the parallax of λ Tauri is, presumably, about one-third that of Algol. Combining these results with Pritchard's value for the parallax of Algol, $0^{\circ}.0556$, it follows, assuming space to be homogeneous, that the difference between the velocities of the extreme ends of the visible spectrum amounts to something of the order of 150m. per second.

Dr. Nordmann points out that this method of investigation offers great possibilities in several lines of research, among which the determination of the parallaxes of variable stars and the gauging of space for dark absorbing material would not be the least interesting from a cosmological point of view.

THE MOVING OBJECT NEAR JUPITER.—Some revised Greenwich positions for the suspected new Jovian satellite are given in No. 4239 of the *Astronomische Nachrichten* (p. 235). This object was observed by Prof. Albrecht at the Lick Observatory on March 8, and its visual magnitude was recorded by Prof. Aitken as 15.0.

DISTRIBUTION OF STANDARD TIME IN EGYPT.—The February number of the Cairo Scientific Journal (vol. ii., No. 17, p. 50) contains a very interesting account, by Captain H. G. Lyons, of the methods of determining and distributing standard civil time in Egypt. The standard now used is the East Europe Time of the thirtieth meridian E. of Greenwich, and Captain Lyons's history of the long sequence of events which led to its adoption is of great interest. The organisation for the distribution appears now to be efficient, and is described and illustrated in the article under notice.

OBSERVATIONS OF ALGOL VARIABLES.—The results of a systematic investigation of the light-changes of ten Algol variables are published by Dr. K. Graff in No. 11 of the *Mitteilungen der Hamburger Sternwarte*. The observations were made during the years 1905, 1906, and 1907, and Dr. Graff, in addition to giving the observational and derived values and the method of reduction, gives charts of the regions surrounding the variables, and a light-curve for each. The stars observed were U Delphini, SW, SY, UW, VW, and WW Cygni, U Sagittae, Z Persei, Z Draconis, and RW Tauri.

NEBULE AND NEBULOSITIES OBSERVED BY PROF. BARNARD.—The purity of the atmosphere at the Mount Wilson Observatory is once more emphasised by some results described by Prof. Barnard in No. 4239 of the *Astronomische Nachrichten* (p. 231, March 17). Nebulosity suspected on earlier photographs are shown unmistakably on those taken during Prof. Barnard's sojourn at Mount Wilson; considerable extensions are shown on others. Messier 8, 16, 17, and 20 are amongst those now described, and in the case of the last-named, the Trifid nebula, extensions appear which have not been seen before by Prof. Barnard; the greatest diameter is $36'$ long, in a S.E. and N.W. direction, and the numerous black lanes, which have made this nebula celebrated, are beautifully shown.

RUSSIAN SCIENTIFIC PUBLICATIONS.

In the Journal of the Imperial Russian Geographical Society, vol. xlii., parts ii. and iii., Mr. V. U. Grigorief writes on the agricultural position of the natives of the Minusin country, Yenisei government. The author carefully examines the economic and legal relations of Russian colonists and aborigines, and considers that agricultural prospects are good, but would be improved by the introduction of scientific methods. The Tartar natives of Minusin have changed but little during centuries of intercourse with Russians, and this persistence of racial characteristics and habits contradicts the opinion of some investigators that the natives will disappear unless Russified. It is interesting to note that cattle-rearing is carried on best on the borders of steppe and forest land, and is not so satisfactory if conducted exclusively in the steppe or the forest.

Mr. A. V. Koltshak describes the last expedition in search of Baron Toll to Bennett Island, which was fitted out by the Academy of Sciences. The Baron left the vessel *Dawn* in May, 1902, with the intention of exploring the island. The search expedition came across some notes by the Baron, indicating the date of his departure for the south. Thorough search failed to reveal fresh traces, and there appears to be no doubt that the names of Baron Toll and his party have to be added to the long roll of explorers who, since Sir John Franklin, have perished in Arctic regions in the cause of science. Mr. K. N. Tultshinsky writes on a commercial journey to Bering Straits, during which he witnessed mining operations in Alaska. Statistics of means of communication in Russia are contributed by Mr. I. F. Borkovsky.

The various Tartar tribes along the Volga and the conditions of their education have been studied by Mme. S. V. Tshitsher, who worked among them during the famine of 1899. She describes the "Iliminsky" system of education, the work of an enlightened, patriotic Russian and Slavophil, N. I. Iliminsky, who spent many years among the heathen tribes, winning their love and esteem by sympathy and knowledge of their languages and conditions, and will be remembered for his philanthropic efforts to introduce Russian civilisation. Statistics of population and interesting illustrations accompany this article.

An important contribution, by Mr. A. I. Voieikoff, bears the comprehensive title of "Distribution of Populations of the Earth in Dependence upon Natural Conditions and the Activity of Man," with numerous statistics and charts. It is tempting to dwell on Mr. Voieikoff's facts and figures at great length. In Siberia, Turkestan, and the Caucasus there are opportunities and land enough to sustain millions if the necessary knowledge and capital were applied. Of countries of which details of population are published, New Zealand possesses the smallest mortality, and this may be accounted for by its agricultural people living in plenty, the small number of children, and the fact that the mothers do not labour in the field; but New Zealand is still in its immigration stage, and there are few old men as compared with Ontario and Australia, where the process of colonisation began earlier. Paucity of births in Australia is a serious question. Such hindrances to population as plagues, artificial feeding of infants, and alcoholism are discussed, and two conclusions arrived at are worth noting:—(1) degeneration undoubtedly exists among the more cultured classes of the Russian nation and in the manufacturing population; (2) alcoholism is less prevalent among the Russian people than among other nations of Europe and their colonies. Alcoholism, i.e. chronic poisoning by alcohol through daily—though moderate—use of *vodka* or beer, must be distinguished from drunkenness. Scarcely a question is left untouched, and the author's studies range over ancient and modern history, medical and registrars' reports, and the trade statistics of many countries.

Vol. xxvii., part ii., of the Proceedings of the Imperial Society of Naturalists of St. Petersburg contains a vast amount of important and interesting material. Prof. N. E. Wedensky contributes an obituary notice, with a portrait and account of the work, of Prof. I. M. Setchenoff, an eminent physiologist, pupil of Du Bois Reymond, Funke, Ludwig, and Helmholtz, founder and

teacher in the Russian physiological school, and a leading authority on the brain and nerves. With the death of this man of science Russia lost a distinguished son. A list of his writings on medical and chemical subjects follows. An exhaustive study of fresh-water Rhizopoda is given by Mr. S. Averintseff, who begins with the physical properties of protoplasm and passes to the structure of shells. A bibliography, lists of species, and handsome plates are given. The first section is taken up with the general morphology and physiology of Rhizopoda, the second is devoted to *R. testacea*, and a further part on *R. nuda* is promised.

The rest of the volume is occupied with papers on the study of nerves. Mr. W. K. Denemark examines and describes the excitability and conductivity of nerves exposed to the action of distilled water. This influence, due to the extraction of salts, produces in nerves the successive functional alterations observed under the influence of positive agents—narcotics, salt solutions, high temperature, &c. Restitution is only effected by the application of sodium salts. The author considers that the presence of sodium salts in the chemical structure of a nerve is absolutely essential for its functions. The effects of a constant current on a nerve which has been subjected to the action of narcotics are described by Mr. N. N. Malisheff. Mr. G. Levitsheff details the action of halogen acids on nerves, and Mme. H. N. Gulnoff the influence of freezing. Prof. N. E. Wedensky contributes a lengthy paper on the effects of strychnine intoxication on the reflex system.

In No. 17 of the Proceedings of the Zoological and Zootomical Cabinets of St. Petersburg University, Mr. V. Zhuk writes on the lamprey, describing external marks, the organs, skin, skeleton, and muscles, with illustrations. An extensive bibliography of Cyclostomi follows. Studies in the anatomy of *Piscicola* are furnished by Mr. V. D. Zelensky, with a German résumé. *P. geometra* is the only species found in European fresh waters. Mr. Zelensky treats (1) metamorphism with reference to the nervous system, and (2) the vessel system. A short bibliography follows. Mr. V. M. Shimkevitch, one of the editors, writes on the correlations of Bilateria and Radiata. In conclusion, he remarks that, speaking generally, the principle of gradual displacement of one source of origin by a neighbouring one, sometimes even developed from another embryonic layer, has had far greater application in embryology than is usually considered. This principle enables a comparison between organs not at all homologous in origin to be established.

In the Proceedings of the Imperial Society of Naturalists, vol. xxvii., part v., Mr. K. D. Glinka records extensive observations with regard to weathering. Observations of this nature, he points out, should not be confined to the surface of soils, but should embrace lower strata. An aluminosilicate dissolved in water may, in favourable circumstances, give rise to a series of new combinations, e.g. zeolites. Analysis of a fresh piece of rock shows that out of 1 per cent. of alumina, 0.72 per cent. is lost in solution. This high solution indicates that a considerable portion of alumina in sandstone does not exist in the form of primary silicates, but in a free form. The author discusses the genesis of the mineral serizite, first discovered in the Taunus range, and taken for talc, to which it bears external resemblance. Numerous tables of analyses are furnished. Taking widely separate districts in Russia, Mr. Glinka describes weathering of biotites, augites, zeolites, &c., at considerable length. There is a short report by Prof. P. A. Zemiatchensky on the rate of weathering of sand and limestone formations, with hints as to calculation of their antiquity. Mr. V. Lehmann sends a contribution, with a plate, on *Terebratulacea* in layers with *Virgatites virgatus* and *Oxyntoceras catenulatus*. The attention of paleontologists has been directed chiefly to the study of ammonites, and it is important to examine other forms. The author corrects the hitherto accepted list.

The Bulletin of the Imperial Academy of Sciences is worthy of comparison with the highest publications of this nature. We have received three handsome volumes, containing the proceedings of the physico-mathematical section. In vol. xxii., Mr. T. Wyragevitch writes on the Actinia of the Black Sea in the neighbourhood of Balaclava, and Mr. A. Borissiak contributes notes on

Black Sea plankton. Astronomers will be interested in the calculations of Mr. G. A. Tikhoff with regard to the position of stars. Of wide general interest is the article by Mr. K. N. Davidoff on the islands of the Indo-Australian archipelago. The fusion of Europeans and Malays in Amboina has produced a curious type, and the Malay tongue is mingled with Dutch and Portuguese words. According to a horrid custom, a would-be bridegroom cannot be accepted until he makes the maiden an offering of the head of an enemy. Mr. A. Birula writes on the Solifugæ of Persia, with frequent references to Mr. R. Pocock's notes on this order. In vol. xxiii., the eminent naturalist Mr. V. Bianchi describes Passeriformes and Palaearctic larks (Alaudinæ), basing his observations on collections in the museums of London, Tring, and Paris. He expresses indebtedness to Dr. Bowdler Sharpe, the Hon. W. Rothschild, and other naturalists for help.

Mr. N. Donitch contributes reports of observations of the annular solar eclipse of March, 1904, made at Cambodia, and of the total solar eclipse of August, 1905. In the latter case, observations were made at Alcalá and Assouan, and Mr. Donitch acknowledges indebtedness for assistance from members of the British Survey Department in Egypt. Notes on inundations at St. Petersburg are furnished by Mr. S. Griboyedoff, and lengthy studies of rainfall in the capital, with diagrams and tables, are given by Mr. E. Rosenthal. Mr. A. Belopolsky's investigations of the radial velocity of the variable star Algol appear in vol. xxiv., and there is another astronomical paper, by Mme. Zhilov, on the proximate absolute orbit of the minor planet Doris. Mr. V. Bianchi describes a new species of pheasant from the mountain regions of western China. Balloon experiments at Kutshino are described by Mr. V. Kuznetsoff. From fossils collected by the polar expedition of Baron Toll, 1900-3, Mme. M. Pavloff is able to draw deductions as to the changes of climate of east Siberia from the Tertiary period. Several papers on aerial mechanics are by Mr. D. P. Riabushinsky, and Mr. M. Golenkin writes on a botanical visit to Java. The report of the geological museum of Peter the Great (Academy of Sciences) concludes the volume.

THE CORALS OF HAWAII.¹

THE madreporarian corals present some of the most difficult problems in the matter of the determination of species that are to be found in the whole range of the animal kingdom. So difficult are these problems that Mr. Bernard in his indefatigable labour on the catalogue of the Madreporaria of the British Museum frankly gave them up, and abandoning the time-honoured binomial system, adopted a new numerico-geographical system of nomenclature.

The difficulty arises from our want of knowledge of the influence played by environmental conditions in the formation of the characters that are presented by a colony of coral polyps and the skeletal structures to which they give rise. In the absence of any direct experimental evidence, upon which alone the problems can be solved, it has been the custom to give specific names to groups of specimens which seem to be separated from other and similar groups of specimens by appreciable differences in the sum total of their characters. The species that are thus constituted inevitably break down if new specimens are found that are intermediate in character between the specific groups already determined, but when they are based on the examination of a very large number of specimens collected from a restricted area, they have at least the advantage of serving a useful purpose for the systematist for a considerable period of time.

It is this system which Mr. Vaughan has adopted in the very handsome memoir of 415 pages, and illustrated by ninety-six plates, which appears under the modest title of "Bulletin 59 of the Publications of the United States National Museum." The author has given himself the task of examining a very large number of specimens from the Hawaiian Islands and the island of Laysan, of forming a conclusion as to the most convenient limits for the

specific groups, and of giving an opinion on the species problem based on his extensive knowledge and experience of these corals. The result is a work which cannot fail to be of essential importance to all those who are interested in the Madreporaria, and a most noteworthy addition to human knowledge.

But in spite of its undoubted value, and in spite of the great skill and labour that have been spent in its compilation, there are some points in this memoir on which it is necessary to offer a few words of criticism, not in any unfriendly spirit, but in the hope that they may influence in some way those who follow in the author's footsteps and attempt to write a memoir of a similar kind.

Our knowledge of the anatomy of the coral polyps themselves, as distinct from the skeletal structures they form, is admittedly imperfect, but the researches of Moseley, Bourne, Fowler, Duerden and others have at least thrown some light on the relations of the genera and on those characters of the species that are comparatively free from environmental variation. Such evidence as these researches afford must be taken into consideration in any satisfactory scheme of classification, and must be used, so far as it is possible to use it, in conjunction with the evidence derived from the structure of the skeletal characters.

In the light of this evidence, for example, the division of the order into the old suborders Imperforata and Perforata breaks down. The perforate Eupsammiidæ are not related to the Madreporidæ and Poritidæ so closely as to justify their inclusion in the same suborder, whereas the imperforate Pocilloporidæ are not related to the Oculinidæ and Styloporidæ with which they were formerly associated, but exhibit much closer affinities with some of the Imperforata. It may be true, as Mr. Vaughan remarks, that there is at present no satisfactory classification of the Madreporaria. It may be that for many years to come no classification will be suggested that will be satisfactory to all students of the group. But there is no reason whatever for ignoring the valuable researches of Duerden, and for retaining a classification that is altogether antiquated and misleading, such as the one that is used in this memoir.

It is clear that until we have obtained far more information than we have at present concerning the structure of the soft parts of the coral anatomy, the skeletal characters must play the most important part in the determination of species, but in such a determination every character that the hard parts exhibit must receive its due recognition. For example, it is well known that some genera, and perhaps some species, are more liable than others to be influenced by the presence of epizoid crustacea, worms, and other animals, and no description of a series of specimens is satisfactory if this influence is altogether ignored. The genus *Pocillopora* is one of those that is particularly liable to the attacks of the crab *Haplocarcinus*, and in a note by Prof. Verrill that is quoted by the author (p. 88), the statement is made that the species of this genus in the Hawaiian Islands are usually subject to the malformations caused by this epizoid. But in the descriptions of the species of this genus the author makes no reference to the crab galls, nor are they clearly shown in any of the photographs that are given to illustrate the text. This is a serious oversight, for when the memoir is used for the purpose of the identification of the species of *Pocillopora*, the galls will at once present a difficulty which the museum curator will not be able to solve by its help. He will ask how far he is able to neglect the presence of these galls, or in what respect they are the determining cause of the general form of growth upon which the species and varieties are founded.

An interesting form described in the volume is *Leptoseris tubulifera*, which differs from the other species of the genus in showing a number of hollow, tubular cavities around which the corallum is folded. Similar tubes are found in the alcyonarian genus *Solenocaulon*, in the stylasterine genus *Erina*, and in the madreporarian genera *Noehelia*, *Amphihelia*, &c., and in all these cases there seems to be little doubt that they are due to the influence on growth of epizoid crustacea or worms. It is difficult to believe that this is not also the case in *Leptoseris tubulifera*, and if it is the specific distinction from *L. hawaiiensis* is not very clear.

¹ "Recent Madreporaria of the Hawaiian Islands and Laysan." By T. Wayland Vaughan. Pp. ix + 427; illustrated. (Washington: Government Printing Office, 1907.)

Finally, objection must be taken to the proposal to substitute the generic name *Aeropora* for the well-known and widely distributed coral that is usually called *Madrepora*, a proposal originally due to Verrill, but one which cannot be accepted. The name *Madrepora* has been used for this genus since the time of Lamarck (1801), and has become definitely established by use in all the principal memoirs on the subject and in the museums of the world. To change it now can lead to no useful purpose, and can but produce a perfectly unnecessary confusion; and the confusion will be all the worse confounded if, as is proposed, the generic name be transferred to the equally well-known imperforate coral *Oculina*.

It may be true that if we are entirely to conform to the so-called rules of nomenclature the change is justified, but these rules were drawn up, not for the confusion of science, but for its convenience and for the sake of simplicity; and when it is found, as in this case, that they are likely to produce just the opposite effect from that for which they were intended they must either be amended or broken. This is by no means an isolated case, for it has been proposed on the same plea that we should use the name *Polypus* for the common octopus, *Astacus* for the lobster, *Potamobius* for the fresh-water crayfish, and that many other changes of a similar kind should be introduced. It has been found in practice, not only inconvenient, but practically impossible, to make these changes, and the customary names are still used. So it will be with the name *Madrepora*. We may argue and plead as we like for the change, but custom is too strong for us, and the proposal will not be accepted. The time has come when the committee of the International Congress of Zoology should reconsider seriously the question of the maintenance of the names of well-known or widely distributed genera, and endeavour thereby to prevent the confusion with which the strict adherence to Linnæan nomenclature threatens us.

S. J. HICKOX.

COMMEMORATIVE DINNER TO SIR WILLIAM RAMSAY, K.C.B., F.R.S.

IN commemoration of the twenty-first anniversary of Sir William Ramsay's election to the chair of chemistry in University College, London, the professors of the college entertained him to dinner on March 18. The Provost, Dr. T. Gregory Foster, was in the chair, and covers were laid for eighty persons. The guests included Lord Rayleigh, Lord Reay, Sir Norman Lockyer, Sir Alexander Kennedy, the Master of the Temple, the Masters of the Worshipful Companies of Drapers, Mercers, and Carpenters, the president of the Society of Chemical Industry, the Clerk of the Fishmongers' Company, Prof. H. B. Dixon, Prof. A. Smithells, Prof. J. M. Thomson, Prof. Meldola, Mr. T. Harrison Townsend, Mr. Henry Higgs, Mr. M. Carteighe, Dr. E. M. Borrigo, Dr. F. Clowes, and Colonel Wolsley Cox.

After the toast to the King had been drunk with due honour, the chairman explained that the dinner was, in the first place, the means of expressing the personal affection and admiration of his colleagues for Sir William Ramsay. Leaving it to others to tell what Sir William's contributions to science had been, the chairman referred to the services he had rendered to the college and to London by establishing a great school of chemistry, and also to his perseverance and tact in questions relating to the re-organisation of the University of London. He had never been weary of expressing the great principles of the true relation of examinations to teaching in the University, and of emphasising the view so strongly held by him that in all university examinations the candidates' teachers should of necessity have a share.

Lord Rayleigh then proposed the health of Sir William Ramsay. He told how, twenty-one years ago, when he was secretary of the Royal Society, papers from Ramsay passed in rapid succession through his hands. Many of the older members, perhaps because they were old, hardly believed of his new methods; but, fortunately, these were accepted. Proceeding, he reminded the company of the work which Sir William had done in investigating the gases of the atmosphere, of the never failing energy which led him to new discoveries.

Prof. Dixon seconded the toast, and in doing so attempted to take the view of a later generation in looking back on Sir William Ramsay's work. Having briefly summarised that work as a contribution to the developments of chemistry, he concluded by comparing his activity to that of radium itself.

The toast having been enthusiastically drunk, Sir William Ramsay replied. After thanking his colleagues for their invariable kindness and helpfulness, and his assistants and students for their loyalty and devotion to their work, he emphasised the debt that he owed to them in whatever he had accomplished, and went on to explain how he had received the first suggestion which led to the discovery of argon, and how generously Lord Rayleigh had allowed him to follow out that suggestion. He dwelt, further, on the questions raised by the chairman in connection with university organisation, and expressed the hope that the University of London would even more fully than it had at present develop the principles to which reference had been made.

At a later stage in the evening, in reply to an inquiry from one of the guests as to when a new laboratory would be built for Sir William, the chairman stated that, though they have the ground and the plans, they have not yet obtained the money for buildings.

Prof. Ker then proposed the health of the other guests, and Lord Reay replied. In view of his close connection with the college as president and chairman, his lordship said that he could hardly consider himself a guest within the college walls, but he thanked the professors for having done him the honour to invite him to commemorate with them Sir William Ramsay's twenty-first anniversary. He proceeded to tell of the great work which Sir William had done in advising Mr. Tata about the organisation of the new institute that he had founded in India, and how Sir William's influence was likely to be extended through the fact that one of his pupils, Dr. Morris Travers, was holding the position of head of that institution. Referring to the need of new laboratories for the chemical department, and the inconvenient accommodation now provided for Sir William Ramsay, Lord Reay hoped that just as at Essen the little cottage had been preserved from which the great Krupp gun factory was developed, so that when the new laboratories were built, which his lordship hoped would be soon, the room in which Sir William Ramsay's discoveries had been made should be also preserved.

Expressions of regret for absence were received from the Chancellor of the University (Lord Rosebery), from the Principal (Sir Arthur Rucker), from Profs. Tilden, Crum Brown, and many others.

NEW SLIDE-RULES.

MESSRS. J. J. GRIFFIN AND SONS, LTD., of Kingsway, London, have sent examples of two slide-rules which they are introducing at a very low price—the longer one, which is 25 cm. in length, at 2s., and the shorter, which is 12.5 cm. in length, at 1s. These rules with their slides are made of card, and the divisions are printed. In point of clearness and accuracy they are nearly equal to the best rules divided on celluloid, and they are vastly superior to the old-fashioned box-wood rules of thirty or forty years ago. In each case the upper lines of the slide and of the rule go from 1 to 10 twice over or from 1 to 100, being what are called "A" and "B" lines, while the lower lines of the slide and of the rule are on twice the scale, being "D" lines. Each is provided with a cursor with chisel pointers both to right and left. The back of the slide and all the remaining spaces on the rule are left plain. The accuracy of the surfaces of juxtaposition is specially noteworthy, and is greatly in excess of what is generally associated with card structures. Each is provided with a paper imitation-leather case. With rules such as these, the real utility of the slide-rule may, it is hoped, be brought home to thousands to whom the expense of the now nearly universal celluloid rule is prohibitive; it may even be hoped that some daring mathematical master in a public school may see fit to inculcate the wholesome practice of making calculations not vastly more accurate than any possible knowledge of the data can be, and use rules such as these both to

exemplify the idea and to let schoolboys know how the daily arithmetic of the laboratory and of the workshop is carried out. Masters should also find them useful for curve tracing on squared paper, as the coordinates of any parabola or rectangular hyperbola, or of any curve representing the law of inverse squares, can be read off from the rule with a single setting of the slide.

With such inexpensive slide-rules it is to be hoped that the makers will in time provide two spare slides at a slight additional cost. For instance, one should be divided so as to give sines and tangents; the second should have a scale of equal parts to give logarithms and a log log or P line for exponential calculations. They might also with advantage print on the back of the rule constants that are frequently required, but at no extra cost.

With such extra slides the master would be able to illustrate further curve tracing, and the line of sines would be specially useful in the optical class for reading off angles of incidence and of refraction with any refractive index, or for showing the necessity of total internal reflection when the scale of sines stops short of the number representing the refractive index. He would also find it useful in solving triangles.

UNIVERSITY AND EDUCATIONAL INTELLIGENCE.

CAMBRIDGE.—Dr. G. H. F. Nuttall, F.R.S., Quick professor of biology and fellow of Christ's College, Cambridge, has been elected to a professorial fellowship at Magdalene College.

MANCHESTER.—By the will of Mr. G. Harrison, who died on January 21, 1900, is bequeathed to Owens College for scholarships or fellowships, or such similar purposes as the council of the college may direct, subject to the words "George Harrison" being always associated with the objects provided for by this bequest.

SIR FREDERICK WILLS has contributed another 5000l. to the fund for establishing a university at Bristol. This brings his contribution up to 10,000l. At the beginning of this year Mr. H. O. Wills promised 100,000l. toward the endowment of the university provided a charter be granted within two years.

The University of London Union Society appears to have made good progress since its formation in July, 1906. The annual report for 1906-7 shows that at the end of the session there were 377 members, 180 of whom were graduates. Monthly meetings for discussion were held during the Lent and Easter terms of 1907, and, in addition, friendly relations have been established with the Students' Representative Council, the University Athletic Union, and the University Musical Society. The new union is modelled on the lines of those existing at Oxford and Cambridge, and deserves the support especially of the students of London colleges affiliated to the University. Intending members should apply to the secretary, Mr. D. W. H. Bell, 20 Masey Road, Plumstead.

A BILL to establish compulsory continuation schools in England and Wales, and to amend the Education Acts of 1870 and 1902 in respect of the age of compulsory school attendance, was introduced in the House of Commons on Tuesday by Mr. Chiozza-Money, and read a first time. In introducing the Bill, Mr. Chiozza-Money said that according to the last census there were in England and Wales 5,000,000 youths of both sexes between the ages of fifteen and twenty-one, and of these not more than 400,000 were receiving any measure of systematic training. This does not include the children of the upper and middle classes, but if 400,000 be added the extraordinary conclusion is arrived at that out of 5,000,000 young people between fifteen and twenty-one years of age only 800,000 continue training after leaving the elementary schools. The practical result is that untrained boys and girls drift into the ranks of the incompetent, the unskilled, and the unemployed. The Bill abolishes all partial or total exemptions of boys and girls under fourteen years of age. It abolishes half-timers, making fourteen years the lowest age at which a boy or girl might leave an elementary school. A continuation scholar is defined as a boy between

the ages of fourteen and seventeen, and a girl between the ages of fourteen and sixteen. The Bill makes it the duty of the education authority to establish continuation schools, with technical classes, and the attendance of continuation scholars is made compulsory on the parent and the employer. The hours of attendance would be six per week, spread over one, two, or three days. The cost of carrying out the provisions of the Bill would be defrayed out of money voted by Parliament.

ABOUT a year ago the Board of Education requested its Consultative Committee to consider and advise the Board what methods are desirable and possible, under existing legislation, for securing greater local interest in the administration of elementary education in administrative counties by some form of devolution or delegation of certain powers and duties of the local authority to district or other strictly local committees. The committee has reported to the Board, and the report has been published (Cd. 3952). A preliminary memorandum states that the findings of the committee are under the consideration of the Board, and that the report has been published to provide information in view of the discussion arising out of the Bill recently introduced in the House of Commons to secure compulsory devolution. The Consultative Committee has arrived at certain general conclusions which should prove of value in assisting intelligent action. Every education committee, it is suggested, should, so far as existing powers go, secure as managers of schools the services of persons familiar with the educational needs of the locality and likely to be regarded with confidence and sympathy by parents, teachers, and the education authority. At the same time, there are certain duties requiring a wide outlook and broad educational experience which, the committee thinks, should be reserved by the authority itself. A certain number of counties exist which might with advantage create some form of local subcommittees and delegate to them duties appropriate to their needs and circumstances. It is very important to notice that the Consultative Committee states that it would be difficult, if not impossible, to devise any uniform system which would give general satisfaction throughout the country. It would be fatal to efficiency if a parochial spirit became predominant in the administration of education. It is desirable by all means to encourage an interest in educational matters in all districts by every legitimate means, but every step must be taken to ensure that the supply of efficient education in every locality is a national matter which must not be left at the mercies of local prejudices.

SOCIETIES AND ACADEMIES.

LONDON.

Royal Society, December 5, 1907.—"Localisation of Function in the Lemur's Brain." By Dr. F. W. Mott, F.R.S., and Prof. W. D. Halliburton, F.R.S.

The brain of the lemur, the lowest of the ape-like animals, does not appear to have been subjected previously to a thorough examination. Page May and Elliott Smith brought a brief communication on the subject before the Cambridge meeting of the British Association in 1904. Their experiments were apparently limited to stimulation of the cerebral cortex, and they have never published a full account of their work. Brodmann has worked out some of the histological details of the structure of the cortex cerebri, and Max Volsch has performed a stimulation experiment upon one lemur. The work of these investigators will be referred to again in the course of this paper.

(1) The brain of the lemur has a simple convoluted pattern, and the fissures are few and for the most part shallow.

(2) The motor areas are limited to the central region of the cortex.

(3) Extirpation of the excitable areas is followed by transitory paralysis of the corresponding regions on the opposite side of the body, and by degeneration of the tracts which pass to the bulbar or spinal grey matter which controls these movements. Degeneration also occurs in commissural (callosal) and association tracts in the cerebrum.

(4) The motor areas are characterised histologically by the presence of Betz cells. Localisation by histological study is therefore possible, and there is a close correspondence of the results so obtained with those obtained experimentally.

(5) There are, however, two types of motor cortex in the lemur's brain. The large type of Betz cell is found in the greater part of the motor cortex, particularly where limb and body movements are represented. The smaller type of Betz cell is found in the area governing face, tongue, ear, and eye movements, and in this excitable region there is a layer of granules; it is therefore probably sensorimotor.

(6) Although the investigation relates in the main to motor representation, histological examination of the occipital (and especially calcarine) region shows it to possess the structural characters of the visual cortex in other animals. That no eye movements could be elicited by faradic stimulation of this region is probably due to the difficulty of the experiment, as explained in the text.

February 13.—“On the Determination of Viscosity at High Temperatures.” By Dr. C. E. Fawsitt. Communicated by Prof. Andrew Gray, F.R.S.

Measurements of viscosity at temperatures higher than 300° C. to 400° C. present considerable difficulties, and until the present year this subject has not been touched by experimenters.

The present communication contains a description of the method used. The method is suitable for the measurement of the viscosity of liquids which are not very viscous—not more than, say, fifty times as viscous as water—and is especially designed for the determination of the viscosity of molten metals and salts. The determination of the viscosity of salts up to 1200° C., or even higher, can be quite satisfactorily carried out by this method. Determinations of the viscosity of metals are much more difficult, owing to the impossibility of preventing a certain amount of surface oxidation. The smallest trace of surface oxidation will completely spoil a series of observations, and the prevention of oxidation is really the chief difficulty in such determinations.

The method used is based on the method originally given by Coulomb, the modifications introduced being due to the special nature of the determinations. In Coulomb's method a horizontal disc is allowed to execute horizontal vibrations about a vertical suspending wire attached to its centre. The viscosity of the liquid can be calculated from the rate of decay of amplitude.

In making a series of observations with this apparatus, the disc is allowed to sink about half an inch below the surface of the liquid. The amplitude of the oscillations is indicated by a pointer (wire) at right angles to the top of the iron rod which carries the disc, and the pointer moves about a circular scale divided into degrees.

With this apparatus, the determination of the viscosity of a liquid is accurate to within 5 per cent. of the absolute value, unless there are special circumstances, as in the case of molten metals, when the results are apt to come out considerably too high.

The results obtained show the availability of this method for the determination of viscosity up to the highest temperature at which a platinum capillary has been used.

Chemical Society, March 5.—Sir William Ramsay, K.C.B., F.R.S., president, in the chair.—The solubility of iodine in water: H. Hartley and N. P. Campbell. The solubility of iodine in water has been determined at 18°, 25°, 35°, 45°, and 55°, and the heat of solution has been calculated from the temperature coefficient of the solubility.—Nitro-derivatives of *o*-xylene (preliminary note): A. W. Crossley and Miss N. Renouf. *o*-Xylene yields two trinitro-derivatives, the one melting at 71° and the other at 115° (compare Noeltig and Thesmar, *Ber.*, 1902, xxxv., 634). A new dinitro-*o*-xylene melting at 82° has also been isolated, and a substance melting at 115° which is a dinitro-derivative of some condensed benzene ring derivative.—Substituted dihydrobenzenes, part ii., 1:1-dimethyl-2:2'-dihydrobenzene and 1:1-dimethyl-2:2'-dihydrobenzene: A. W. Crossley and Miss N. Renouf. Dimethyldihydrobenzene prepared by the elimination of 2HBr from 1:5-dibromo-1:1-dimethylhexahydrobenzene has been proved to consist of a mixture in approximately equal

parts of these two hydrocarbons, thus refuting the adverse criticisms of Harries and Antoni (*Annalen*, 1903, cccxxviii., 66) on the work published by Crossley and Le Sueur (*Trans.*, 1902, lxxxii., 821).—The viscosity of aqueous pyridine solutions: A. E. Dunstan and F. B. T. Thole. The authors have repeated their experiments on the viscosity of aqueous pyridine solutions, and find that the same discontinuities occur in the curve as were previously observed (compare Hartley and others, *Proc.*, 1908, xxiv., 22).—The action of thionyl chloride on the methylene ethers of catechol derivatives, ii., piperonyloin, piperil, and hydroperiprin: G. Barger and A. J. Ewins.—Traces of a new tin-group element in thorianite: Miss C. de Brereton Evans. The dark brown sulphide of the new element separates with arsenious sulphide, from which it differs in being soluble in water, to form a deep brown solution. It yields a hygroscopic brown oxide, which on reduction in hydrogen furnishes a grey metal. Incidentally, proof was obtained of the presence in thorianite of arsenic, mercury, bismuth, molybdenum, and selenium.—The sulphination of phenolic ethers and the influence of substituents: S. Smiles and R. Le Rossignol. The authors have confirmed the conclusion that the sulphonium base derived from phenetole is produced in three stages, at which the sulphinic acid, sulphoxide, and base are consecutively formed, by isolating the sulphinic acid.—The relation between unsaturation and optical activity, part ii., alkaloid salts of corresponding saturated or unsaturated acids: T. P. Hilditch.—The wandering of bromine in the transformation of nitroaminobromobenzenes: K. J. P. Orton and Miss C. Pearson.—A new isomeride of vanillin occurring in the root of a species of Chlorocodon, preliminary note: E. Goulding and R. G. Pelly. The results obtained show that the odorous constituent of Chlorocodon root is a monomethyl ether of a dihydroxybenzaldehyde having an odour intermediate between that of vanillin and piperonal, but which is not identical with vanillin or any of its known isomerides.—The volatile oil of the leaves of *Ocimum viride*, preliminary note: E. Goulding and R. G. Pelly. The composition of the oil is approximately as follows:—thymol, 32 per cent.; alcohols (calculated as C₁₀H₁₆O), 40 per cent.; esters (calculated as C₁₀H₁₇OAc), 2 per cent.; the remainder consists chiefly of a terpene (or possibly a mixture of terpenes), which is a liquid of pleasant lemon-like odour, boiling at 160°–166°.—Experiments on the synthesis of the terpenes, part xii., synthesis of terpins, terpinols, and terpenes derived from the methyloxypropyl-cyclopentanes, Me.C₂H₄.CHMe₂: W. N. Haworth and W. H. Perkin, jun.—The initial charge of the radium emanation: N. V. Sidgwick and H. T. Tizard.

Geological Society, March 4.—Prof. W. J. Sollas, F.R.S., president, in the chair.—*Metricorynchus brachyrhynchus*, Deslong., from the Oxford Clay near Peterborough: E. T. Leeds. Two skulls have recently been obtained from the Saurian zone of the Lower Oxford Clay, in the neighbourhood of Dogsthorpe, Peterborough. The mandibles were missing. The two specimens have been referred to *Metricorynchus brachyrhynchus*. This is believed to be the first recorded occurrence of the species in England.—The high-level platforms of Bodmin Moor, and their relation to the deposits of stream-tin and wolfram: G. Barrow. In this area there are three platforms:—one, which is marine and of Pliocene age, terminating in a steep slope at 430 feet; a second, at a height of 750 feet, seen about Camelford and at the foot of Delabole Hill; and a third, a little under 1000 feet, first recognised on Davidstow Moor. The superficial deposits which bear tin above the 750-foot platform differ markedly at times from those below it. These deposits are not so concentrated as the stream-sorted material below, but they have been frequently worked in past times. The veins from which the wolfram is derived have been found close to the points where the “wash” is enriched by their denudation. The success of working depends to some extent on the slope of the granite-floor on which the detritus rests. On Bodmin Moor the larger marshes have a floor of kaolinised granite, but there is a difficulty in working it at many points in consequence of the water-logging by peaty water.

Royal Anthropological Institute, March 10.—Prof. W. Ridgway, president, in the chair.—The origin of the crescent as a Mohammedan badge: Prof. Ridgway. It

was demonstrated that the crescent badge had its origin, not in the new moon, as generally supposed, but in the well-known amulet formed of a claw or tusk. These in course of time were placed base to base, with the result that the crescent form arose. The two tusks are joined together by string or by a silver plate, but in later examples the amulet is carved out of one piece of material and all traces of the joint are lost, except that in some cases a panel of ornament survives to mark where the joint was originally. Examples were exhibited from Turkey, Greece, Africa, and New Guinea, and Prof. Ridgeway traced the amulet back so far as the date of the sanctuary of Artemis Orthia at Sparta, where an example was discovered in the recent excavations. The crescent seen on modern English horse-trappings was also shown to have originated in this amulet.—Some Megalithic remains in central France: A. L. Lewis. The paper dealt principally with monuments in the neighbourhood of Autun, including the dolmen at La Rochefort and the standing stones at St. Pantaléon. With these last the author compared other lines of stones at Carnac, Gezer, Dartmoor, and in the Khasi Hills. He also dealt with the two types of circle in Scotland, and showed that they had each a definite locality, those with recumbent stones being found only around Aberdeen, while those with great chambered cairns in the middle arc found round Inverness. He was of the opinion that the two types of circle were contemporary, and that the differences were solely due to local influences.

Physical Society, March 13.—Dr Charles Chree, F.R.S., president, in the chair.—The distribution in electric fields of the active deposits of radium, thorium, and actinium: S. Russ. The first experiments were made with the active deposit produced from radium emanation. The amount of active deposit directed to a kathode decreases as the pressure in the vessel is reduced, but after a certain pressure is reached the amount going to an anode shows a corresponding increase under the same conditions. The main feature brought out is that at the lowest pressure reached almost as much activity is obtained on the anode as on the kathode, while at atmospheric pressure the activity of the latter is about twenty times that of the former. Similar experiments conducted in hydrogen, air, and sulphur dioxide indicate that the collisions between the active deposit particles and the gaseous molecules play an important part in the distribution of the active deposit in electric fields. Experiments on similar lines with thorium and actinium show that while at atmospheric pressure nearly the whole of the active deposit particles of thorium are directed to the kathode, this is not necessarily the case with actinium. Other observations indicate that the sign of the electrical charge exhibited by the active deposit particles of actinium is a function of the distance that these particles have travelled through the containing gas before reaching the electrodes.—Note on certain dynamical analogues of temperature equilibrium: Prof. G. H. Bryan. Attention is directed to the following results of a method described in 1900 (*Archives Néerlandaises*) under the title of "Energy Accelerations":—(1) In a system of uniformly distributed particles, a stationary state of statistical equilibrium cannot exist under the Newtonian law of force, whether the forces between the particles be attractive or repulsive, except when the particles are at rest in a state of unstable equilibrium. (2) For energy-equilibrium to exist the force between the particles, if repulsive, must vary according to a higher power of the inverse distance than the square; if attractive, it must vary according to a lower inverse power than the square of the distance. (3) In a system in which the kinetic energy cannot be expressed as a quadratic function of the velocities with constant coefficients, the equations of energy-equilibrium no longer take the form of linear relations between the various components of kinetic energy, so that the commonly assumed analogue between temperature and kinetic energy becomes inapplicable.

CAMBRIDGE.

Philosophical Society, March 2.—Dr. Hobson, president, in the chair.—(1) The formation of lactic acid and carbonic acid during muscular contraction and rigor mortis; (2) the complete hydrolytic decomposition of egg-

albumin at 180° C., and on the constitution and synthesis of dead and living albumin: Dr. Latham.—(1) The formation of γ -pyrone compounds from acetylenic acids; (2) the action of mustard oils on the éthyl esters of malonic and cyanoacetic acids: S. Ruhemann.—The absorption spectra of some compounds obtained from pyridine and collidine: J. E. Purvis.—The limitations of the copper-zinc couple method in estimating nitrates: J. E. Purvis and R. M. Courtald.—A double sulphate of guanidine and aluminium: F. Ferraboschi.—The property of a double-six of lines, and its meaning in hypergeometry: H. W. Richmond.—Energy accelerations and partition of energy: C. W. Follett.

PARIS.

Academy of Sciences, March 16.—M. H. Becquerel in the chair.—The extension of the theorem of Clausius: E. H. Amagat.—The characters of tuberculous infection in their relations with the diagnosis of tuberculosis: S. Arloing and L. Thévenot. In a *post mortem* examination the absence of macroscopic lesions is no proof of the absence of tuberculous infection, and this is the explanation of the occasional want of agreement between the experimental diagnosis (*scro-agglutination* or application of tuberculin to the skin or conjunctiva) and the *post mortem* examination.—Report by the committee on the application of the metric system to French coinage. The views of various commissions dealing with this question from the date of the foundation of the metric system are reviewed, and the question of the advisability of introducing a 25-centime piece considered, and reported on unfavourably. To preserve the unity of the metric system the committee conclude that the only coins should be 1, 2, and 5 centimes, 1, 2, and 5 decimes, 1, 2 and 5, 10, 20, 50, and 100 francs, and this view is confirmed by the academy.—The dispersion of light in celestial space. The history of the question and the first results: G. A. Tikhoff.—The presence of water vapour in the atmosphere of the planet Mars: P. Lowell. Photographic observations made at the Flagstaff Observatory, Arizona, U.S., during January of this year, establish the presence of water vapour in the atmosphere of Mars. The plates used were rendered sensitive to the extreme red rays, and with an exposure of two to three hours were capable of photographing the spectrum in the neighbourhood of the band α , the most intense band due to water vapour. Photographs of the spectrum of Mars clearly show this band α , whilst the spectrum of the moon taken on the same plate shows no trace of this band, thus eliminating the effects of the earth's atmosphere (see NATURE, March 12, and p. 497 of the present number).—The series of Taylorian polynomials: A. Buhl.—The general solution of the problem of equilibrium in the theory of elasticity, in the case where the forces are applied at the surface: A. Korn.—The electrolysis of solutions of hydrochloric acid: Th. Guilloz. In a recent note on this subject M. Doumer, on the basis of his experiments, raises objections to Hittorf's theory of electrolysis. In the present note the author directs attention to recent work by Noyes and Sammet on the mobility of H and Cl ions in dilute solutions of hydrochloric acid, and points out that these researches afford an experimental proof that the disturbances due to the evolution of oxygen during electrolysis are without effect on the transport numbers.—The velocity of evaporation and a method of determining the hygrometric state: P. Vaillant. The liquid the evaporation of which is being studied is placed on a balance, and the rate of evaporation deduced from ten oscillations of the beam. The formula $Q = B(F - f)$, where Q is the quantity evaporated in a given time, F the pressure of the saturated vapour, and f the pressure of the water vapour in the atmosphere surrounding the balance, was shown to be valid experimentally. By using pure water and pure sulphuric acid successively the method can be applied to give f , the determination being reduced to two weighings.—The hydrates of arsenic acid: M. Auger.—The pseudomorphoses of the microclines in microgranites from the valley of the Meuse (Ardennes): Jacques de Lapparent.—The magmatic parameters of the volcanic series of Anglona and Logudoro (Sardinia): M. Deprat.—Asymmetry of the figure and its origin: Richard Liebreich. From the examination of several thousand

human skulls, dating from prehistoric times to the present day, the author considers that asymmetry is the normal form of the human figure, and is not, as supposed by Lombroso, a sign of degeneration. A simple physiological reason is put forward as the cause of this asymmetry, which is regarded as the necessary result of the erect position of the human species.—The quantity of X-rays absorbed and transmitted by the successive layers of tissues: H. Guilleminot.—An attempt at grafting articular tissues: Henri Judet.

CALCUTTA.

Asiatic Society of Bengal, March 4.—Certain unpublished drawings of antiquities in Orissa and northern Circars: Manmohan Chakravarti. This paper invites attention to the eleven folios of drawings received by the society in December, 1822, and forming a part of the remarkable collection of Lieut.-Colonel Colin Mackenzie. It takes up two of the folios dealing with the antiquities of Orissa and northern Circars: the one of the smaller size (B) has eighty-five originals, while the other of the larger size has two originals and thirty-two duplicates, and gives a brief description of each in the Appendices A and B. They contain interesting drawings of Hindu sculptures, pillars, and other architectural designs, drawn in 1815.—The exact determination of the fastness of the more common indigenous dyes of Bengal, and comparison with typical synthetic dye-stuffs, part II., dyeing on silk: E. R. Watson.—Oil of *Larsonia alba*: D. Hooper.—A general theory of osculating conics: Prof. Syamadass Mukhopadhyaya.

DIARY OF SOCIETIES.

THURSDAY, MARCH 26.

ROYAL SOCIETY, at 4.30.—Bakerian Lecture: The Thermal and Electrical Conductivities of Metals and Alloys at Low Temperatures: Prof. C. H. Lees, F.R.S.—Note on the Values of the Board of Trade Standards of Current and Electromotive Force: T. Mather, F.R.S., and F. E. Smith.—Note on the Rise of Meteorological Balloons and the Temperature of the Upper Air: A. Mallock, F.R.S.—The Navigation of the Air: Dr. H. S. Hely-Shaw, F.R.S.
ROYAL INSTITUTION, at 3.—Standardisation in Various Aspects: (a) Electrical Engineering; Dr. R. T. Glazebrook, F.R.S.
CHEMICAL SOCIETY, at 8.—Annual General Meeting.—Presidential Address: The Electron as an Element: Sir William Ramsay, K.C.B., F.R.S.

FRIDAY, MARCH 27.

ROYAL INSTITUTION, at 9.—Radio-active Change in the Earth: the Hon. R. J. Straut, F.R.S.
PHYSICAL SOCIETY, at 5.—(1) Notes on the Plug Permeameter; (2) On the Use of Shunts and Transformers with Alternate Current Measuring Instruments; (3) On Wattmeters; (4) Experimental Demonstration of Alternate Current Wave Propagation in a Helix: Dr. C. V. Drysdale.
INSTITUTION OF MECHANICAL ENGINEERS, at 8.—Combustion Processes in English Locomotive Fire-Boxes: Dr. F. J. Brislce.—Combustion Processes in American Locomotive Fire-Boxes: L. H. Fry.
ROYAL GEOGRAPHICAL SOCIETY, at 8.35.—A March Journey to the Plains of the Caribou: E. Thompson Seton.

SATURDAY, MARCH 28.

ROYAL INSTITUTION, at 3.—Electric Discharges through Gases: Prof. J. J. Thomson, F.R.S.

MONDAY, MARCH 30.

ROYAL GEOGRAPHICAL SOCIETY, at 8.30.—Geographical Conditions affecting the British Empire: (r) British Islands; Dr. J. Mackinder.
ROYAL SOCIETY OF ARTS, at 8.—Fuel and its Future: Prof. V. B. Lewis.
INSTITUTE OF ACTUARIES, at 5.—On Reversionary Bonuses as affected by Expenses and Variations in Rates of Mortality: H. H. Austin.

TUESDAY, MARCH 31.

ROYAL INSTITUTION, at 2.—The Egyptian Sudan: its History, Monuments, and Peoples, Past and Present: Dr. E. A. Wallis Budge.
INSTITUTION OF CIVIL ENGINEERS, at 8.—Some Methods of Heating adopted in Hospitals and Asylums recently built: E. R. Dolby.

WEDNESDAY, APRIL 1.

ROYAL SOCIETY OF ARTS, at 8.—Dr. Schlick's Gyroscopic Apparatus for Preventing Ships from Rolling: M. Wurl.
GEOLOGICAL SOCIETY, at 8.—The Geological Structure of the St. David's Area (Pembrokeshire): J. F. N. Green.

SOCIETY OF PUBLIC ANALYSTS, at 8.—Lead in Tartaric Acid, Cream of Tartar and Baking Powders: The President.—(1) The Nitrogen Factor for Casein; (2) The Recovery of Amyl Alcohol from Waste Gerber Liquors: H. D. Richmond.—Carapa Oil: Dr. J. Lewkowitsch.—A Rapid Method for the Estimation of Mercuric Sulphide in Aqueous Solution: S. G. Verdoorn.

INSTITUTION OF MECHANICAL ENGINEERS, at 8.

THURSDAY, APRIL 2.

ROYAL SOCIETY, at 4.30.—Probable Papers: Complete Survey of the Cell Limitation of the Cerebral Cortex of the Lemur: Dr. F. W. Mott, J. H. R. and Miss A. M. Kelly.—The Alcoholic Ferment of Yeast Juice, Part III. The Function of Phosphates in the Fermentation of Glucose

by Yeast Juice: A. Harden and W. J. Young.—The Antagonistic Action of Calcium upon the Inhibitory Effect of Magnesium: S. J. Metzler and J. Auer.—Studies on Enzyme Action, XI. The Hydrolysis of Raffinose: Prof. H. E. Armstrong, F.R.S., and W. H. Glover.—Studies on Enzyme Action, XII, Emulsin: Prof. H. E. Armstrong, F.R.S., Dr. E. F. Armstrong, and E. Horton.—On Some Features in the Hereditary Transmission of the Albino Character and the Black Piebald Coat in Rats, Paper II.: G. P. Mudge.

ROYAL INSTITUTION, at 3.—The Animals of Africa: R. Lydekker, F.R.S.
ROYAL SOCIETY OF ARTS, at 8.—The Navigation of the Air: Prof. H. S. Hely-Shaw, F.R.S.

LINNEAN SOCIETY, at 8.—Altitude and Distribution of Plants in Southern Mexico: Dr. Hans Gadow, F.R.S.—The Anatomy of some Sapotaceous Seedlings: Miss Winifred Smith.—Notes on some Sponges recently collected in Scotland: Dr. N. Annandale.

CIVIL AND MECHANICAL ENGINEERS' SOCIETY, at 8.—Efficiency of Boiler Heating Surface: C. Humphrey Wingfield.

CHEMICAL SOCIETY, at 8.30.—The Condensation of Epichlorohydrin with Phenols: D. R. Boyd and E. R. Marle.—Rate of Hydrolysis of Chloroacetates and Bromoacetates, and of α -Chlorohydrin by Water and by Alkali, and the Influence of Neutral Salts on the Reaction Velocities. Preliminary Note: G. Senter.—A New General Method of Preparing Diazonium Bromides: F. D. Chattaway.—On the Probable Nature of the Impurity found in the Triphenylmethane Spectrum: W. N. Hartley.—The Constituents of Cyprus Origanum Oil. Isolation of a New Terpene (Origanene): S. S. Pickles.

INSTITUTION OF ELECTRICAL ENGINEERS, at 8.—High Speed Electrical Machinery: G. Stoney and A. H. Law.

FRIDAY, APRIL 3.

ROYAL INSTITUTION, at 9.—The Modern Motor Car: Lord Montagu of Beaulieu.

INSTITUTION OF CIVIL ENGINEERS, at 8.—Notes on the Foundations of an Indian Bridge: G. W. N. Rose.

SATURDAY, APRIL 4.

ROYAL INSTITUTION, at 3.—Electric Discharges through Gases: Prof. J. J. Thomson, F.R.S.

CONTENTS.

	PAGE
Misleading Seismology	481
German School Botany	481
Elementary Physics	482
Our Book Shelf:—	
Bell: "The Mechanism of Speech."—Prof. John G. McKendrick, F.R.S.	483
South: "The Moths of the British Isles."—W. F. K. Kienitz-Gerloff: "Physiologie und Anatomie des Menschen mit ausblicken auf den ganzen Kreis der Wirbeltiere."—W. W.	484
Stephenson: "The Elements of Geography"	484
Hemmelmayer and Brunner: "Lehrbuch der Chemie und Mineralogie für die vierte Klasse der Realschulen"	484
Letters to the Editor:—	
The Cotton Plant.—W. Lawrence Balls; Lieut.-Colonel D. Prain, C.I.E., F.R.S.	484
The Isothermal Layer of the Atmosphere.—C. E. Stromeyer; W. H. Dines, F.R.S.	485
The Penetrating Radiation.—Prof. A. S. Eve	486
Mosaic Origin of the Atomic Theory.—Dr. John Knott	486
Tabulated Values of Certain Integrals.—Harry M. Elder	486
Notes on Ancient British Monuments. VII.—The Aberdeen Circles (Continued). (Illustrated.) By Sir Norman Lockyer, K.C.B., F.R.S.	487
Proposed Alteration in the Calendar. By W. T. L. Peculiarities in the Structure of some Heavenly Bodies	490
Sir John Eliot, K.C.I.E., F.R.S. By A. P.	490
Notes	492
Our Astronomical Column:—	
Water Vapour in the Martian Atmosphere	497
The Dispersion of Light in Interstellar Space	497
The Moving Object near Jupiter	497
Distribution of Standard Time in Egypt	497
Observations of Algol Variables	497
Nebulae and Nebulosity observed by Prof. Barnard	497
Russian Scientific Publications	498
The Corals of Hawaii. By Prof. S. J. Hickson, F.R.S.	499
Commemorative Dinner to Sir William Ramsay, K.C.B., F.R.S.	500
New Side-rules	500
University and Educational Intelligence	501
Societies and Academies	501
Diary of Societies	504

THURSDAY, APRIL 2, 1908.

ELECTRICITY AND MATTER.

The Corpuscular Theory of Matter. By Prof. J. J. Thomson, F.R.S. Pp. vii+172. (London: Archibald Constable and Co., Ltd., 1907.) Price 7s. 6d. net.

THE present volume is an expansion of six lectures delivered by Prof. J. J. Thomson in his capacity of professor at the Royal Institution. It is a simple and clear account of the development of the corpuscular, or, as some prefer to call it, the electronic, theory of matter to explain the passage of electricity through metals and gases. The last two chapters are devoted to consideration of the properties of model atoms built up of corpuscles, and the evidence in favour of the view that the number of the corpuscles in an atom is about the same as its atomic weight in terms of hydrogen.

The proof of the independent existence in matter of electrons of mass small compared with the atoms has supplied a great stimulus to the attack of that most important problem of physics, the connection between electricity and matter. This attack has been conducted both on experimental and theoretical lines, and while only a beginning has been made, yet the results already obtained have been instrumental in giving a much clearer and deeper insight into the conditions of the problem, and afford considerable justification for the hope of still greater advances in the immediate future. There has been a tendency in some quarters to view with alarm, if not with distrust, the philosophic speculations of the physicist, more particularly when dealing with the question of the constitution of the chemist's atom. It is apparently considered indelicate to pry too deeply into the mysteries of atomic structure, especially if mathematical analysis is the instrument of investigation. This attitude appears somewhat unreasonable to the average physicist, and arises largely from a misunderstanding of the relative place of theory and experiment in physical science. A student of the history of physical science cannot fail to be impressed by the notable part played by mathematical physics in the development of the subject, and there is no obvious reason why the cooperation between the two branches of the subject should not be as fruitful in the future. The physicist from his training is seldom content merely to describe phenomena, but seeks for some form of theory that will serve to give a general explanation of the facts and to show their relation with other branches of the subject. In dealing with such a complicated and intangible problem as the constitution of the atom, it is essential that theory should go hand in hand with experiment, for without some kind of theory the experimenter is in most cases as helpless as a ship without a rudder.

This attitude of the physicist is very well expressed by Prof. J. J. Thomson in the opening chapter. After

mentioning the postulates on which the corpuscular theory of matter is based, he proceeds:—

“From the point of view of the physicist, a theory of matter is a policy rather than a creed; its object is to connect or coordinate apparently diverse phenomena, and above all to suggest, stimulate and direct experiment. It ought to furnish a compass which, if followed, will lead the observer further and further into previously unexplored regions. Whether these regions will be barren or fertile experience alone will decide; but at any rate, one who is guided in this way will travel onward in a definite direction, and will not wander aimlessly to and fro.”

The working out of the logical consequences of a simple theory and the comparison of the deductions with experiment is eminently scientific, and of great importance to the specialist who is able to form a critical estimate of the adequacy of the theory. The danger of too free a use of hypothesis is not so much for the specialist as for the general reader who, from lack of expert knowledge or of time, is unable to form a critical judgment on the matter. In such a case there is a tendency to assume that a theory which may be admittedly tentative in character represents the final, accepted views on the subject.

Two of the most interesting chapters of the book are devoted to the application of the corpuscular theory to explain the passage of electricity through metals. In one chapter the theory developed is similar in general outlines to that originally advanced by the author and the late Prof. Drude. The corpuscles which are responsible for the passage of electricity through a conductor are supposed to be free from the molecules for a time sufficiently long for them to be in temperature equilibrium with the molecules of the metal. This implies that the corpuscles behave like a gas, and that temperature equilibrium is reached when the mean kinetic energy of the corpuscle has become equal to that of a molecule of a gas at the same temperature. The passage of the current is then supposed to result from the drift of these free charged corpuscles, brought about by the action of the external electric field applied to the conductor. This theory is shown to account in a satisfactory way for the connection between thermal and electric conductivities of metal, and with minor assumptions for the Peltier and Thomson effects. Prof. Thomson points out that this form of theory suffers from one very serious defect. In order to account for the conductivities observed in metals, it is necessary to assume the presence of such a large number of free corpuscles in the metal that the specific heat of these alone, quite independently of the atoms of the metal itself, is about ten times greater than that experimentally observed. The author in the next chapter develops another form of the theory which is free from this objection, and at the same time fits in with the facts to be explained equally well as the first theory. The second method supposes that the corpuscles are not free in the metal except for the time required to pass from one atom to another. They are pulled out of the atoms of the metals by the action of the

surrounding matter, and immediately pass into adjacent atoms. This view materially reduces the number of corpuscles required for the transfer of electricity. In both these forms of theory the atoms of the metal itself are supposed immobile, and to play no direct appreciable part in the transfer of the current.

The important question of the type of radiation to be expected from a metal on the above theories is fully considered. Since the corpuscles are suddenly started and stopped, they must radiate energy in the form of thin pulses analogous to the pulses which are supposed to constitute the Röntgen rays. Lorentz has shown that if this radiation be analysed by means of Fourier's series, the amplitude of the long waves agrees closely with that deduced independently of such assumptions by means of the thermodynamical theory. Prof. Thomson, however, points out that the main radiation must consist of short waves analogous to very easily absorbed Röntgen rays. It would be of great interest and importance if the presence of such a type of radiation from metals could be experimentally detected. In another chapter the author explains the construction and properties of his well-known "model" atoms built up of rings of rotating corpuscles. No one can fail to admire the ingenuity displayed in the construction of such atoms, and in showing the remarkable way in which they imitate many of the known properties of the atom. On this hypothesis the properties of the atom are dependent on the number and arrangement of the negative corpuscles. The corresponding positive electricity, which is distributed throughout the volume of a sphere, merely serves as a cement to hold the atom together. This form of atom, while it has many advantages from the point of view of calculation, is somewhat artificial, for it implicitly assumes very peculiar properties for the positive electricity. To say that a positively charged body is one that has lost a negative corpuscle is not an explanation, but begs the question of the nature of positive electricity. The trend of modern views is to diminish in some directions the importance of the negative charge and to emphasise that of the positive. This is borne out by the author's estimates that the number of free corpuscles in an atom is about the same as its atomic weight in terms of hydrogen. Until we have a clearer idea of the nature of positive electricity we cannot hope to form a clear view of the constitution of the atom. The proof of the existence of a positive electron—the counterpart of the negative—if such exists, would be of enormous importance to theory and experiment. The problem of the nature of positive electricity is now very much to the fore, and it is to be hoped that we shall not have to wait too long for a solution.

Like all Prof. Thomson's books, the present volume is lucidly and simply written, while the mathematical analysis required for the development of the consequences of the theory is made as simple as possible. To all those interested in the latest views of the connection between electricity and matter this book will be very welcome.

E. R.

CHARTING THE WORLD'S COMMERCE.

Atlas of the World's Commerce. Compiled from the Latest Official Returns at the Edinburgh Geographical Institute, and edited by J. G. Bartholomew. (London: G. Newnes, Ltd.) Twenty-two parts, each 6d. net.

MR. BARTHOLOMEW is a skilled hand at map-making, and in setting himself to chart the commerce of the world he has undertaken a gigantic task. With the aid of 176 large pages of coloured plates, containing more than 1000 maps and diagrams, he attempts to describe the products, imports, exports, commercial conditions and economic statistics of all the leading countries of the world, and he says quite justly that the successful accomplishment of such a work must throw much needed light on the solution of the great problem of international trade which we in British politics call "the fiscal question." His first object is to show whence we derive our food, drink, clothing, and all that we use in our daily lives. No better text could be chosen for the enlightenment of our politicians, whatever be their fiscal views, and indeed of all who would understand where England really stands in the world of commerce, and what are the essentials of her future as the central force of a great Empire.

The very immensity of Mr. Bartholomew's undertaking tends to lessen its topical value. For instance, the last three years have been momentous in their effect upon the sources of British food supply, and Mr. Bartholomew can be of little help to the man who would understand how far we are dependent upon foreign and how far upon colonial supplies, when he only carries us down to the year 1903. Canada, for instance, figures in Mr. Bartholomew's diagrams as yielding less than 86 million bushels of wheat. The produce of her western section alone was in 1906 considerably in excess of that figure. The fiscal controversy is especially associated with the food production of the newer countries, and the usefulness of Mr. Bartholomew's diagrams, so far as the fiscal controversy is concerned, goes little beyond the course of our dependence upon the older countries, such as the United States, Russia, &c. For his distribution of the chief sources of the British supply of wheat, Mr. Bartholomew brings us no further down than the 1901-3 average, from which we see that the Canadian percentage was 8.4 and the United States percentage 43.5. The limited usefulness of such figures is evident when it is noted that in 1906 the Canadian proportion was at least 12½ per cent. and the United States proportion 37 per cent. There may have been insuperable difficulties in carrying the averages down to a more recent period, but it is obvious that, in the absence of more recent figures, it is necessary to endorse with qualification Mr. Bartholomew's claim that in his new atlas "the whole fiscal question is clearly illustrated."

We may note one other respect in which the topical usefulness of Mr. Bartholomew's investigations is limited, and it is a vital one. In dealing with the import and export trade of the United Kingdom

(p. 33), the imports are lumped together with no allowance for the fact that in some cases large proportions are re-exported, and therefore, except from the point of view of the shipper, the gross totals throw no light on the industry of the country, in fact they can only mislead. The importance of this allowance for re-exports is shown in the textile group. Thus, of the 52,400,000. worth of imports of cotton, no less than 7,000,000. worth was re-exported, and of the wool imports of 26,600,000. no less than 11,200,000. If Mr. Bartholomew had these calculations in mind, he would hardly have ventured upon the conclusion he draws in a note to this diagram in the following words:—

"It is at once evident that articles of food greatly preponderate, the value amounting indeed to 40 per cent. of the total. Raw material accounts for more than 28 per cent., of which 16½ represent textile fibres."

But we would not leave Mr. Bartholomew's atlas without a recognition of the enormous labour it must have involved, and of its successes in several directions. The maps are excellent, and the table of the commodities of commerce and the gazetteer of countries and ports of the world have obvious uses.

MASONRY AND CONCRETE ARCHES.

Symmetrical Masonry Arches. By M. A. Howe. Pp. x+170. (New York: John Wiley and Sons; London: Chapman and Hall, Ltd., 1906.) Price 10s. 6d. net.

THE author's object in this text-book has been to present in a simple and direct form a method which can be employed in the design of masonry arches according to the elastic theory. He points out that since such arches are built of materials and under conditions which are more or less uncertain in character, the use of rigidly accurate formulæ is not necessary.

The first portion of the book consists of two chapters, in which the various formulæ which are required in the design of such arches are deduced, and then several examples are worked out in detail to illustrate the application of the formulæ. Independent formulæ are obtained for the effects of bending, axial thrust, and temperature; these formulæ are then combined, but the author points out that as the effect of axial stress is small, except in very flat arches, it may in general be neglected in obtaining a combined formula. For symmetrical arches fixed at the ends, the following conditions must be satisfied, viz., the central angle and the relative elevations at the supports must each remain unchanged, and the length of span must remain constant; Mr. Howe is therefore able to obtain three equations involving the three unknown quantities—moment, vertical reaction, and horizontal thrust at the supports of the arch. He then proceeds to deal with a number of special cases of loading, and discusses fully the temperature effects; graphical representations are frequently used to show the results obtained by analysis.

The last part of this portion of the book is devoted first to a discussion of the trustworthiness of the

elastic theory when applied to ribs composed of natural stone voussoirs, and to plain and reinforced concrete ribs (the author comes to the conclusion that the theory may be used with confidence so long as no tensile stresses occur); and secondly to a collection of empirical formulæ for the thickness of the ring at the crown and at the supports in stone arches, and for the thickness of the abutments. The examples of the applications of the formulæ, which are fully worked out, cover the following cases:—(1) An arch for a single-track railway bridge of 60-feet span and a rise of 8 feet, the arch ring to be constructed of granite; (2) an arch with a clear span of 50 feet and a rise of 10 feet, constructed of reinforced concrete (in both cases the maximum stresses produced by dead load, live load, and changes of temperature are computed); (3) the author takes again the data employed in the second example, and gives an ingenious and much shorter method for working out the values of the horizontal reactions and bending moments at different sections of the arch. In the fourth chapter, dimensioned illustrations are given of a few typical arches, and, in the form of an appendix, data have been brought together for 500 arch bridges of masonry, plain concrete, and reinforced concrete. The data in this appendix will be of considerable service to engineers who may be called upon to design arch bridges of one or other of these materials. T. H. B.

OUR BOOK SHELF.

Das Kausalitätsprinzip der Biologie. By Dr. Friedrich Strecker. Pp. viii+153. (Leipzig: W. Engelmann, 1907.) Price 3 marks.

VON BAER said that the chief end of biology was to refer the formative forces of organisms to the general forces and vital directions (*Lebensrichtungen*) of the Kosmos. According to the mechanists this is rapidly being done; according to the neo-vitalists this is not being done at all, for the characteristic activities of living creatures cannot be described in the formulæ of physicochemical happenings, and there is in the organism an autonomous regulative force or *entelechy*. Biologists oscillate between these two positions, or dogmatically trench themselves in either of them, very much as philosophers did in regard to empiricism and rationalism before Kant's critique showed a better way. Dr. Strecker seeks to be a daysman between the two biological schools, laying his hands upon them both, pointing out that there is truth on both sides, but that there is a third outlook which dominates both. For the practical methods and analytic results of the "Entwicklungsmechaniker," such as Roux, the author has an appreciative respect; his criticism is epistemological rather than biological; he does not think that there is any hope of rationally interpreting organisms in mechanistic formulæ. For the neo-vitalists he has also much that is good to say, for they at least do not give a false simplicity to the facts of life; on the other hand, he does not hold with an "entelechy," which seems to be an ingenuous way of bundling all the difficulties into one term, and saying "there's an end of it." The fact is that the mechanists and the vitalists are tarred with the same stick, they are *ekgenetic*, they seek to interpret results which have come to be, instead of concentrating attention on the process of becoming, which is the

engenic method. In the inorganic world we have to do with passive things, with an externally conditioned series of sequences; in the world of organisms we have to do with creative agents, with an internal activity, like that of our own psychical life, with engenic doings, not with ekgenic occurrences. The only way to get at the gist of the organism, its internal creativeness, is as we get at our own internal life—engenicly. Man crowns the evolution series, his most distinctive feature is his psychical experience, and it is in the light of this that we must try to read the secret of the dominating, correlating, regulating principle in the life of organisms. This, at least, is what we understand this exceedingly abstract treatise to mean.

J. A. T.

Pharmakognostisches Praktikum. By Dr. Ludwig Koch and Dr. Ernst Gilg. Pp. viii+272; illustrated. (Berlin: Gebrüder Borntraeger, 1907.) Price 6.80 marks.

It appears that the recent edition of the German Pharmacopœia has placed additional responsibility upon the German pharmacist, and he is now required to be practically cognisant with the microscopical characteristics of the medicinal plants in their entire as well as in their powdered form. The book before us deals with the above subject, and is intended to be used as a laboratory handbook for pharmaceutical students.

The initial chapter is devoted to the methods of preparing microscopical specimens of the respective plants and their powders, and staining them appropriately. In addition, the adequate magnification for drawing and photographing the respective objects is fully dealt with. The microscopical characteristics of all the official medicinal plants, or rather the parts of them which are official, are fully described, and following upon such description is an account of the microscopical appearance presented by the powdered drug. The order followed in the book corresponds to the part of the plant which is official; for instance, the cortices are all considered together, the rhizomes together, the roots together, and so forth. The whole subject is treated in great detail, and abundant illustrations are scattered through the text of the microscopic appearance of the respective preparations. The volume commences with a table of contents and concludes with a register, from which latter it appears that no fewer than eighty drugs are described.

Die Pendulations-theorie. By Dr. Heinrich Simroth. Pp. xii+564; maps. (Leipzig: K. Grethleius, 1907.) Price 12 marks.

TAKING as his basis Dr. Paul Reibisch's "Ein Gestaltungsprinzip der Erde" (1901), supplemented by Mr. D. Kreichgauer's "Die Äquatorfrage in der Geologie" (1902), the author of the curious volume before us discusses the effects which would, in his opinion, be produced on the animal life of the globe by secular changes in the direction of the polar axis. Mr. Kreichgauer, it seems, is of opinion that in the course of geological time the two poles have actually changed places, and also that during such oscillations huge "wobbles" or waves have been produced in the earth's crust in the intervening latitudes. These "wobbles," if we understand him rightly, the author believes have produced marked effects on the distribution of animal life, having, so to speak, "shaken" the various groups into particular positions. The distribution of all the chief groups is discussed according to the new theory, and in many cases illustrated by maps.

Without in any way committing ourselves to an opinion on the author's views, it may be pointed out

that several of these maps are inaccurate. The one illustrating the distribution of ichthyosaurs (p. 249) ignores, for instance, the fact that remains of these reptiles have been obtained from more than one locality in Africa, which is left a blank in the map in question. This being so, it is difficult to see what value attaches to Dr. Simroth's conclusions in this and several other cases.

R. L.

The Minimising of Maurice, being the Adventures of a very small Boy among very small Things. By Rev. S. N. Sedgwick. Pp. ix+150. (London: Elliot Stock, 1907.) Price 5s. net.

A WORD to "grown-ups" which prefaces this volume asserts "there are quite a lot of things in it which only children are able to understand"—the italics are not ours. There are "baby" language, indifferent verse, and talking animals in great profusion, but, despite all these, we are very doubtful as to whether the book will really appeal to children. The illustrations are good, and these at least will set young readers questioning and observing. We should have preferred a simple account in good literary English of the forms of animal life introduced, and so would most of the children we know.

Les Progrès de la Photographie astronomique. By Prof. P. Stroobant. Pp. 34; illustrated. (Brussels: M. Hayez, 112 rue de Louvain, 1907.)

THIS thirty-four page extract from *l'Annuaire astronomique de l'Observatoire royal de Belgique pour 1908* is typical of those services which Prof. Stroobant is continually rendering to contemporary astronomy. It contains in a concise and lucid form descriptions of the methods by which photography renders such valuable services to astronomical research. The photography of regions, such as nebulae, the discovery of minor planets and satellites by the photographic method, the investigation of the physical peculiarities of comets and of the solar sphere, the observations of variable stars and of proper motions are all dealt with in turn, and in each case the text is illustrated by excellent reproductions of actual photographs. Duplicate, detachable plates, for use in a stereoscope, are included in order to illustrate the value of Prof. Wolf's stereocomparator method for the detection of small proper motions and of variations in magnitude.

W. E. R.

- (1) *I laterizi.* By Ing. G. Revere. Pp. x+298; 134 figures. Price 3.50 lire.
- (2) *La Tecnologia delle Saldature autogene dei Metalli.* By Prof. S. Ragno. Pp. iii+129. (Milan: Ulrico Hoepli, 1907.) Price 2 lire.

THESE are recent additions to the "Manuel Hoepli," a collection which numbered 000 of these small pocket-books on April 1, 1907. Mr. Revere's book deals with brickwork. It opens with general and historical information, and then deals in succession with the selection and extraction of the clay, its subsequent preparation, brick-making machinery, the drying process, and finally the brick kiln. The need of such a book has arisen through the great development that has taken place in the brick industry in recent years, notably in Italy, where improved machinery has been largely introduced.

Prof. Ragno's manual deals with the soldering and welding of metals. Five methods are distinguished, namely, the electric, oxy-hydrogen, oxy-acetylene, oxy-gas, and aluminium methods. The advantages of these methods are discussed. Two appendices deal respectively with the cutting of metals by means of an oxygen jet and the methods of producing oxygen commercially.

LETTERS TO THE EDITOR.

[The Editor does not hold himself responsible for opinions expressed by his correspondents. Neither can he undertake to return, or to correspond with the writers of, rejected manuscripts intended for this or any other part of NATURE. No notice is taken of anonymous communications.]

Mendelian Characters among Shorthorns.

I HAVE just come upon a phenomenon which, although it may be interesting to naturalists, may be alarming to breeders of Shorthorn cattle. It is that the roan Shorthorn is a hybrid, and must remain so for ever.

The data on which this statement is based are to be found in a paper on the inheritance of coat-colour in cattle, by Miss A. Barrington and Prof. Carl Pearson, published in *Biometrika* for March, 1906.

For the purposes of their paper these authors, having examined in the Shorthorn Herd-book the pedigrees of more than 2000 calves, noted the colours of these and their parents, and analysed and tabulated the figures found. They divided the sires and dams according to the colours under which they are registered, and then made an analysis of the colours of the calves produced. There are five different colours registered, viz. red, red and little white, red and white, roan, and white. A sire of any one of these colours may be bred with a dam of any one of them. Miss Barrington and Prof. Pearson made an analysis of the colours of the calves produced by bulls of all the five colours when bred with cows of every one of the same five colours. For instance, they found that by mating 514 roan bulls with 514 roan cows there had been produced eighty-six red calves, thirty-one red with little white calves, thirty-five red and white calves, 278 roan calves, and eighty-four white calves.

These cases at a first glance give rise to no Mendelian suggestion. No more does the full collection of cases. Miss Barrington and Prof. Pearson failed to find in them any Mendelian indications.

But if we consider the nature and history of the Shorthorn breed the Mendelian characters come out. The Shorthorn is a composite breed. A hundred and fifty years ago it consisted of at least three, and possibly four, different strains. The chief ancestry came from the Low Countries. They were red-and-white flecked cattle—*fleckvieh*. In Durham and Yorkshire they wedged themselves in between the original British black cattle in the north and the Anglo-Saxon red cattle in the south. They also possibly reached westwards to the Longhorns. The Anglo-Saxon red cattle were probably the purest. The northern black cattle and the western Longhorns were not pure. They were intermixed with white cattle—cattle which had been introduced originally by the Romans. It was impossible for the recently introduced flecked cattle not to become mixed with black blood in the north, with white blood in the north and west, and with red blood in the south. Breeders, however, did not like the black blood, and it was soon bred out. The white was retained, but, so far as I know, it is difficult to say how much Anglo-Saxon red blood was retained. It is on that ground any uncertainty arises. But, if red blood was retained, it was nearly related to the red and white blood introduced from the Continent.

If we look upon the Anglo-Saxon red cattle and the Low Country red-and-white cattle as being of one race, then, since the black blood was bred out, the Shorthorn is a combination of two races. If we look upon these red and red-and-white cattle as different races, then the Shorthorn is a combination of three.

I tried to find Mendelian characters among the cases collected by Miss Barrington and Prof. Pearson by assuming the Shorthorn to be a three-fold combination, but unsuccessfully. Then Prof. Arthur Thomson's account of the blue Andalusian fowl in his newly published "Heredity" suggested the idea that the red, red and little white, and red-and-white Shorthorns might be taken as one race. Are not these Shorthorns splashed reds just as one of the blue Andalusian parents is "splashed white"? The Shorthorn, then, becomes a composite breed with one parent white and the other splashed red.

Assuming this to be so, then the Mendelian characters of the Shorthorn come out. There are one or two small discrepancies, but they can be explained. It is sometimes difficult to say whether a calf is red-and-white or roan. Thus all that are labelled red and white may not be really red and white, and all that are labelled roan may not be really roan. Among Shorthorn breeders white calves are not desirable. Cases of false registration and the substitution of another calf for a white—that is, giving a red or a roan calf a white calf's pedigree—have not been unknown. Thus some red or roan calves may not be the progeny of the parents attributed to them. For the same reason that white calves are undesirable, a good many white calves are not registered at all. Thus the real numbers of white calves born are greater than the numbers registered, and the number of matings recorded is less than it ought to be through matings that produced white calves being unrecorded. For the reason that white calves are not wanted, a white bull and a white cow are very seldom mated. Thus very few such matings are registered.

Assuming the Shorthorn to be a combination of two races, a red and white, then, according to the Mendelian formulæ as exemplified by the blue Andalusian fowl, we ought to get the following results:—

- (1) Red crossed by red should give red calves.
- (2) White crossed by white should give white calves.
- (3) Red crossed by white should give roans.
- (4) Roans inbred should give reds, whites, and roans in the proportion of 1, 1, 2.
- (5) Roans crossed by reds should give roans and reds in equal proportions.
- (6) Roans crossed by whites should give roans and whites in equal proportions.

This, giving heed to the expected exceptions as indicated above, is what we find, viz. :—

	Red	Roan	White
438 Reds crossed by reds give ...	413	25	0
3 Whites crossed by whites give ...	0	0	3
71 Reds crossed by white give ...	3	68	0
514 Roans crossed by roans give ...	152	278	84
456 Roans crossed by reds give ...	226	230	0
23 Roans crossed by whites give ...	0	14	9

For the breeder of Shorthorns this means that, if he wishes to avoid white calves, he is limited to three crosses, viz. red with red, red with roan, and red with white. He gets whites when whites are bred together, when whites are bred with roans, or when roans are bred together.

JAMES WILSON.

Royal College of Science, Dublin, March 19.

The Nature of γ and X-Rays.

IN a letter to NATURE of January 23 (p. 270) Prof. Bragg mentions the results of some experiments on γ rays from which he concludes that the ether pulse theory of γ rays is not tenable, but which support his theory that the γ rays consist of neutral pairs revolving in a plane containing their direction of translation. From the close resemblance of X-rays to γ rays he assumes that they also consist of neutral pairs. His reasoning seems to be that if the γ rays are ether pulses only, they should produce in any substance which they strike secondary kathode rays which come off equally in all directions, and if they do not the ether pulse theory cannot be correct.

Prof. Bragg's experiments show that the secondary kathode rays coming from the side of a substance on which the γ rays fall differ in the amount of ionisation they produce from those coming from the side from which the γ rays emerge. Also that the "emergence" kathode rays from a substance of low atomic weight are greater than those from a substance of higher atomic weight, while with the "incidence" kathode rays the substance of high atomic weight gives off more than the substance of lower.

I have been working for some time upon the secondary kathode rays produced by X-rays with a form of apparatus which can be easily adapted for a repetition, with X-rays, of Prof. Bragg's experiments with γ rays (see *Amer. Jour. Sci.*, October, 1907, p. 285). I have therefore tried to

find out whether his results with γ rays hold also for X-rays.

Following closely Prof. Bragg's method of procedure with pairs of metals consisting of lead and aluminium, copper and aluminium, and copper and lead, I found that in every case the ionisation due to the "emergence" secondary kathode rays was greater than that due to the "incidence" rays. The "incidence" secondary rays were, in different experiments, from 50 per cent. to 90 per cent. of the "emergence." It appeared, however, that the difference was not as large in the case of lead as in the case of copper. This is in agreement with Prof. Bragg's result for γ rays.

A separate experiment showed that the thickness of the layer of copper from which the secondary rays can emerge is not great enough to absorb the primary rays to an extent sufficient to account for the marked difference between the "emergence" and "incidence" secondary rays.

On the other hand, however, both the "emergence" and "incidence" secondary radiation produced greater ionisation when it came from a metal of high atomic weight than when it came from a metal of lower atomic weight. This difference was very marked with the above-mentioned pairs, and also with lead and carbon. This is directly opposite to the effect observed by Prof. Bragg with γ rays.

It should be noticed that the ionisation chambers used in these experiments were so short that a very small fraction of the secondary X-rays coming from the metals was absorbed in them, while they were long enough to absorb all the secondary kathode rays. Thus practically all the ionisation was due to the secondary kathode rays.

Although these experiments, together with those of Prof. Bragg, show that for both X-rays and γ rays the secondary kathode rays are not produced equally in all directions, I cannot agree with Prof. Bragg that the evidence is conclusive that X-rays and γ rays must consist of some type of radiation other than electromagnetic pulses. The reason he gives on the neutral pair theory for lack of symmetry in the secondary rays is that these secondary rays are the negative parts of the primary pairs. As these primary neutral pairs possess momentum in the direction of propagation, it is natural to suppose that their negative parts, when liberated from the positive, would be more likely to continue in their original direction than to turn back.

On the other hand, an electromagnetic pulse possesses momentum also in the direction of propagation. Though little is known of the mechanism of the production of secondary kathode rays by ether pulses, it is not unreasonable to suppose that an ether pulse could contribute some of its momentum to the secondary kathode particles, causing them to go more in the direction of propagation of the primary than in any other.

Since we know that X-rays, which come from a region where electrons are being violently accelerated, must consist in part, at least, of ether pulses, and since all the experimental evidence previously gathered in regard to their nature has been favourable to the ether pulse theory, it seems to me more reasonable to look to the ether pulse theory for an explanation of both X-rays and γ rays than to a theory of neutral pairs. It must, however, be recognised that this lack of symmetry in the secondary kathode rays is a difficulty in the way of the ether pulse theory which needs explanation. I hope soon to determine by means of absorption experiments whether this lack of symmetry is due to a difference in penetrating power or quantity of secondary kathode rays.

CHARLTON D. COOKEY.

Sheffield Scientific School, Yale University, New Haven, Conn., March 7.

Martinmas in May.

SIR NORMAN LOCKYER in his book on "Stonehenge" connects the festival of St. Martin, which falls on November 11, with the beginning of winter in the Mayan year, which falls astronomically on November 9. It is, however, seem to be aware that there was another festival of St. Martin which fell on May 12. This was the *Subventio St. Martini*, a festival which was appointed to be observed by a council held at Tours in 841 to commemorate the restoration of the relics of the

saint to Tours after they had been hidden on account of the incursions of the Northmen. Sir Harris Nicolas in his "Chronology of History," published in 1838, stated that the festival was still observed in the province of Tours. The date of the appointment of the festival is late, but reverence for sacred stones survived until long after that time, and it might be worth while to try to discover whether any connection can be traced between the appointment of the festival and an attempt to discourage the old stone-worship.

It seems clear that it was this festival of the *Subventio* which is alluded to in the entry in the Parker Manuscript of the Old English Chronicle for the year 913—"In this year about Martinmas King Edward bade build the northern fortress at Hertford, between the rivers Maran, Beane, and Lea; and then after that in the summer between Gang-days and Midsummer King Edward went with part of his forces to Maldon in Essex." The King opened his campaign at Martinmas, May 12, by commencing a fortress at Hertford, and then between Rogation-tide (May 23-25) and Midsummer he marched to Maldon. The fact that the chronicler regards the period between May 25 and June 24 as summer has a bearing on the question of the observance of a May-November year. It is likely that the Martinmas of 919 is also the May festival, but it is clear that the Martinmas of 918 and of 921 must be the festival in November. C. S. TAYLOR.

Banwell, March 24.

An Annotated Copy of Newton's "Principia."

ABOUT three months ago I was asked to look through a list of old books, which had recently come to Australia as portion of the personal property in an estate which had been in Chancery some years. The books had become the property of a resident of this city, who employed an agent to dispose of them.

Among a number of books which I bought was a copy of Newton's "Principia," and when I came to examine it more closely I found that it was one of the original edition of 1687, with the imprimatur of S. Pepys "Reg. Soc. Præses Julii 5 1686." I found also that it contained nearly five pages of MS. additions and corrections for a second edition, written in Latin, as well as numerous corrigenda throughout the book, with occasional detailed alterations in the diagrams.

Inside the cover, in another handwriting, there was the following note:—"The Amendments in this book were written by Sir Isaac's own hand. See his original MSS. of his Optics in Trin. Coll. Library, Cambridge."

I have since compared the handwriting of these "additions and corrections" with a facsimile of Sir Isaac Newton's handwriting in the Commonwealth Parliamentary Library, and consider there is a distinct similarity.

I have now had the first two pages of the notes photographed, and have forwarded them to the librarian of the college referred to in the note, with the view of a further comparison.

The notes are punctiliously detailed, with a reference to each page, and the alterations in the body of the text of the book are made with almost microscopic care. As the notes are headed as intended for a second edition, I cannot see what other source but the mind and hand of the author they could have come from.

I am informed by the former owner of the book (Mr. H. C. Elderton) that it belonged to the family of James, of Ightham Court, Kent, probably to Sir Demetrius James, who is supposed to have been knighted about the year 1685. It and a number of other old books formed a small collection which were set apart, packed in oak chests, and stowed away in an old clock-tower, where they remained ever since until brought to Australia.

I shall let you know the result of my inquiries, and, in the meantime, perhaps some of your numerous scientific readers may be able to throw some light on the book's history, for if it should be Sir Isaac Newton's personal copy, and contain his personal notes, it must become an object of great interest to the scientific world.

BRUCE SMITH.

149 Phillip Street, Sydney, Australia, February 25.

TWO COUNTY BIRD-BOOKS.¹

TO write a history of the birds of Yorkshire, so far the largest of our English counties as to include almost every kind of natural feature to be found in this country, was no light undertaking, and Mr. Nelson is to be congratulated on the conclusion of his labours, extending over many years, and upon the able way in which he has arranged and digested the unrivalled and exceptionally complete mass of material placed at his disposal, which has been accumulated by the numerous ornithologists who, from the time of Thomas Allis (who wrote the first complete list of Yorkshire birds in 1844) down to the present day, have been engaged in working out the local ornithology of this great section of England. This information Mr. Nelson has been able to supplement with his own observations for many years past. The scope of the work is comprehensive. The account

of each species includes particulars of faunistic position, distribution, migration, nidification, folklore, varieties, and vernacular names; whilst the report on the birds of Yorkshire prepared for the York meeting of the British Association in 1844 by Thomas Allis is here published for the first time. A voluminous introduction deals with the physical aspect of the county and the several districts into which the great diversity of its natural features has made it convenient to divide it. Following this, migration, so remarkable on the Yorkshire coast from its geographical position, is duly considered, and the chapter concludes with a review of the avifauna of the county.

Situate about midway on the eastern seaboard of the British

Isles, and directly opposite the European continent, Yorkshire is sufficiently far south to include species the distribution of which is of the southern type—such as the nuthatch and nightingale, which find in it the northern limit of their range—while it is sufficiently far north to admit of the inclusion of such species as the curlew, dunlin, &c., “which here meet with their southern breeding limits.” These remarks, though true on the whole, must not be taken in too literal a sense, for both the last-named birds breed in Great Britain further south than Yorkshire. The author states that the avifauna of Yorkshire, compared with that of other counties, stands unrivalled,

not only in its numerical extent, but also—a circumstance of much greater significance—in the inherent richness which is shown by the number of species breeding annually within its limits. That this should be so would be anticipated by anyone who has read the topographical description of the county, in which are found wild mountainous country, heathery moorlands, and romantic dales; pasture and arable land, woodlands, marshlands, chalk wolds, and a coast line 117 miles long, and one of the most diversified possessed by any English county. We find, indeed, in Yorkshire almost every kind of natural feature that England affords.

The configuration of the coast line materially increases the advantage of the position, which is still more enhanced by the possession of two such projections as Spurn Point and Flamborough Head (the latter on the same parallel of latitude as Heligoland, the island which is so famous for the vast hordes of



FIG. 1.—Unusual Site for a Dipper's Nest, on the River Nidd. From "The Birds of Yorkshire." R. Fortm.

¹ (1) "The Birds of Yorkshire. Being a Historical Account of the Avifauna of the County." By T. H. Nelson, with the cooperation of W. Eagle Clarke and F. Boyes. 2 Vols. Pp. xiv+xii+843; illustrated. (London: A. Brown and Sons, Ltd., 1907.) Price 25s. net.

(2) "Notes on the Birds of Kent." By R. J. Balston, Rev. C. W. Shepherd, and E. Bartlett. Pp. xix+465; with 9 plates and a map. (London: R. H. Porter, 1908.) Price 20s. net.

migratory birds which pass and re-pass it in spring and autumn), which as a locality productive of rare birds has few equals.

We accordingly find Yorkshire accredited with a list of 325 species after excluding 21 recorded on insufficient evidence. Of these no fewer than 123 are considered to be annual breeders. It is in this list of breeding species (which it owes to its size, diversity of natural features, surface, soil and climate, and to its peculiar geographical position) that the strength of the Yorkshire list mainly consists.

Among the resident species are the nuthatch, woodlark, and lesser spotted woodpecker, which here find the northern limit of their general distribution in Britain during the breeding season; the raven, buzzard, and peregrine falcon—now reduced to a few pairs—as well as the goldfinch and the sheldrake, both of which are local. The nightingale, reed-warbler, wryneck, turtle dove, and stone curlew

(among the summer migrants) reach in Yorkshire the northern limit of their annual distribution during the breeding season. If we add to these and other well-known midland and southern species the very local pied flycatcher, which is common in many localities, and such moorland and fell birds as the merlin, twite, dipper, grey wagtail, grouse, golden plover, dunlin, and curlew, various wild ducks, and the numerous rock birds which resort to the sea cliffs in the nesting season, we get a breeding avifauna which is probably unequalled by that of any block of adjacent English counties equal to Yorkshire in size, although it is surpassed by that of North Wales, with a much smaller area. Yorkshire is, however, singularly deficient in terns.

Among the many rare and accidental visitors may be mentioned the Siberian meadow bunting (the only

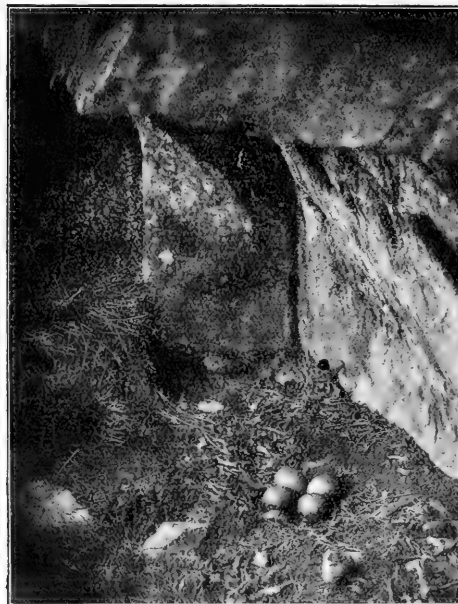

FIG. 2.—Peregrine Falcon's Eyrie, North-west Yorkshire. From "The Birds of Yorkshire."

known European example), the cuneate-tailed gull—better known as the wedge-tailed or Ross's gull—and Bulwer's petrel, which were both until recently unique as British specimens, the desert wheatear, rufous turtle dove, McQueen's bustard, &c. Like other districts, Yorkshire has lost several breeding species, the kite, the harriers, bittern, bustard, grey plover, avocet, ruff, godwit, and black tern. Probably the practice of climbing for eggs, which will claim the attention to which many ornithologists will turn first, is the guillemot and the famous "loomery" of the Flamborough cliffs. A most interesting and unusual feature of this bird and its breeding habits, the extraordinary variation in the colour and position of its eggs, will be found here; as also of the practice of climbing for eggs carried out on the Yorkshire cliffs, accompanied by some excellent illus-

trations, which make the account given quite clear to those who have never been present at this harvest of the cliffs. Notwithstanding the fact that about 80,000 eggs is the average yearly "take," it is stated that there is no diminution in the numbers of the birds. But the egg collecting is carried out with some care, some portions of the cliffs being "fallowed" occasionally; and, moreover, there are dangerous parts of the cliffs which are never climbed, and in these places the birds hatch out their first eggs without interference.

In the carefully prepared articles on each species, the history in the county of the declining or recently extinct birds is fully given, every bit of available evidence and information having been most praiseworthy preserved. Especial attention may be directed to the excellent articles on the raven, the rarer birds of prey, and the great bustard. A point is made of the earliest allusion to each species as a Yorkshire bird. In this connection we notice that the author has included as an early reference to the black grouse a letter from Fr. Jessop to John Ray, written in 1668, saying he had stuffed the skins of a moor cock and moor hen. We may point out that at that time these names were used to designate the cock and hen of the red grouse. For although the word grouse is now applied almost exclusively to the red grouse, it probably originally belonged to the black grouse or black game, our "grouse" being commonly spoken of until comparatively recent times as moorgame. That the latter was the bird referred to by Jessop is quite clear from another letter addressed by him to Willoughby (*vide* Derham's "Philosophical Letters," p. 367). The work is lavishly illustrated, and many of the illustrations are most interesting, or give pleasing scenes of bird-life. But the greater part are photographs of nests and eggs, and as satisfactory or unsatisfactory as such illustrations must be. Many, indeed most, photographic representations of the nests and eggs of small birds are "faked"—the nests tilted forward or unnaturally exposed in order that the contents may be seen, and the eggs must be arranged in order that all of them may come into view. You cannot see the eggs in a reed-warbler's nest by looking at it sideways, nor can you see the whole five eggs in any small nest without looking directly down upon it. Tits' nests are not naturally exposed to the gaze. Pictures of nesting scenes and sites are far more valuable.

The photographing of birds' nests has been rather overdone. A large proportion of such pictures are worth little, and many of them do not really represent what would be seen by the observer; and it is to be regretted that in their desire to get prints of the nests of different species the disciples of this new sport have made many a pair of birds desert their eggs, and by keeping away their parents have caused young birds to suffer from prolonged exposure to cold, from which they so often do not recover. No nest of a really rare bird, at all events, should be subjected to risks of this kind. The same species can always, if it is really desirable, be photographed where it is comparatively common.

But there are many good and useful pictures in these volumes. The dipper's nest on a branch, the sparrowhawk's, showing the tufts of down; the falcon's eyrie, and the crow's nest showing the tree, may be mentioned; while sites such as Cautley Crag, the island in Swinney Reservoir, the Humber mudflats at Spurn, Hornsea Mere, and the many views of cliff scenery, as well as the snow scene with red grouse sitting on the roof of a moorland cottage in Teesdale, illus-

trate most excellently the ornithological characters of Yorkshire. The errata, in which there is a curious misprint, is not quite complete, and omits to state that *lesser spotted woodpecker* should be *greater* (p. 276), and *blue tit* should be *great tit* (p. 114). There are two indices, but unfortunately no map.

The latest work on the birds of Kent (which from its title, indeed, does not claim to be a complete history of the subject) is founded on the material brought together in connection with a certain area of that county; but in that limited portion of the county it was noticed that the avifauna would scarcely be of sufficient importance to fill even a small work. It was therefore found advisable to take in the whole of the county. It was also thought desirable to collect all the material hitherto written, and give to those who have done so much towards our knowledge of the birds of Kent full credit for their observations. This has in the main been carried out, and the result has been a compilation giving us a great deal of information about the birds of Kent. Indeed, so anxious have the authors been to give all possible credit to those who have written anything about the local ornithology that they have been misled into including in their book a number of notes and observations which were not worth reproduction, and the discursiveness of which has made it extremely difficult to arrange the facts in the present work in an orderly and systematic manner. In fact, the book is very well described by its title, and although the reader has never been led to expect a systematic history (from a local point of view) of the birds of Kent, the book is a storehouse of facts relating thereto.

We should have been glad to have a complete book on the subject to fill up a blank in the county bird-book shelf; a volume with more personal observations from the authors, and a compilation more complete. The present volume has not been brought up to date. For instance, a valuable paper published in the *Zoologist* so long ago as February, 1907, has been quite overlooked. Had this been consulted the sheldrake might have been added to the list of ducks breeding in Kent, while the status in the county of the shoveller and some other ducks, as given in the volume under notice, would have been somewhat modified. Nor has the information relating to the various birds always been brought down even to recent years.

Concerning the guillemot breeding on the Kentish coast, we have a description of the breeding colony in St. Margaret's Bay, written so long ago as 1852, and a note on the same made in 1887, but nothing more recent in the way of exact information about the bird breeding on the coast at the present day, although we are told that the bird is, during the summer and breeding season, very numerous. It would surely have been worth the while of one of the authors to ascertain the exact conditions of the breeding place or places after the lapse of twenty years. This is only one instance out of several. Again, on turning to the articles on the birds more particularly associated with Kent, we find that the greater part of that on the Sandwich tern consists of matter written in the eighteenth century, and we are left in doubt as to whether this bird still breeds annually on the coast or not.

The article on the Kentish plover is more satisfying, although it consists almost entirely of quotations (excellent in themselves), with no qualifications, remarks, or annotations by the authors. An exact statement of the status in Kent of each bird would have been welcome. Kent is credited with a list of 320 species, but of these the black grouse is stated to have long been extinct. We cannot quite follow the authors in

their application of this word when they go on to say that many of the birds, which might also come under the same word, such as the crane, bustards, cream-coloured courser, &c., are likely to become occasional visitors, *although comparatively extinct in the county* (italics ours). There are certainly no grounds for calling the last-named bird "extinct" in the county, as it has never been anything more than a purely accidental straggler to these islands; while the other two species are absolutely, and not only comparatively, extinct as native birds in Great Britain, although they may occur from time to time as visitors. Speaking of the rarer visitors to Kent, the authors remark on one very extraordinary circumstance, viz. that a very large number of the rare seed-eating and other birds should have been found on the Sussex coast, whereas none of them have been observed in the adjoining county of Kent; and the suspicion here expressed that most of these birds have been introduced by human agency has certainly been entertained by many people.

The introduction contains an excellent topographical account of this maritime county (with its 140 miles of coast lapped by tidal water) and its natural features. There is an index, and a map of a handy size and sufficient for its purpose. The frontispiece to this well-got-up volume is a picture from a photograph of a bit of woodland with a woodcock on her nest, and is one of the most beautifully executed and successful pictures of this kind we have ever met with. The difficulty in at first seeing the sitting bird, and the failure of the eye to pick it up at once on again glancing at the picture, as well as the way the figure and details of the bird seem to grow, on the sight when once it is located, or located once more, is an admirable representation of the real facts of such cases. The other eight full-page plates depict birds—like the masked shrike, which has only occurred once in Great Britain—especially associated with Kent, and (especially the one named) are very welcome. But they would have been more useful had they been more correctly coloured. The wing coverts of the lesser kestrel should not have been grey, and the legs of the avocet should have been bluish-grey and not olive-green, a colour which has been also used for the legs of the Kentish plover instead of the correct black or brownish-black. Ornithologists will be glad to have the voluminous literature relating to the birds of Kent collected in this nice-looking volume, the paper, binding, and general get-up of which do the publisher great credit.

MODERN NITRE BEDS.

EVER since the invention of "villainous saltpetre," the provision of a sufficiency of nitrates has been one of the preoccupations of a ministry of war, and the necessity has become greater rather than less under the conditions of modern warfare. The potassium nitrate that was required for the fabrication of gunpowder is now replaced by the nitric acid used in making the various types of nitro-explosives, but it is always the nitric ion that has to supply the oxygen, and the consumption in a modern battle attains a magnitude of which our immediate predecessors using black powder had no conception. Indeed, one truly scientific argument against war may be drawn from the enormous losses it occasions in the world's limited stock of combined nitrogen.

Up to the middle of the nineteenth century, India was the only source of nitrates on a large scale, and though a certain amount of nitre was recovered from the efflorescence of the walls of cellars and from artificially-made beds of earth mixed with decaying animal

matter, it was not until the closing of the seas to France during the wars of the Directory that the necessity of an internal supply of nitrates directed the attention of the French savants to the process of nitrification. Their labours reduced to a system the making of nitric beds, but the maximum production was never more than about 5 kilos. of nitre per metre cube after the bed had been established for two years.

It was nearly eighty years later that the researches of Schloesing and Müntz, Warrington and Winogradsky showed that nitrification was brought about by bacteria, and at the same time afforded a justification and an explanation of the procedure which had been worked out empirically for the nitre bed. The discovery of the nitrate of soda deposits in Chile left no place for the old nitre beds, but as MM. Müntz and Lainé point out in a very interesting memoir lately presented to the Société d'Encouragement pour l'Industrie nationale (l. cix., pp. 951-1042. Paris, 1907), the conditions that prevailed at the close of the eighteenth century might recur, and France be again driven to manufacture her war stores of nitrates at home. The authors have therefore been studying in detail the process of nitrification on a large scale to ascertain if the process could be so quickened and intensified as to have any practical value. Starting with sulphate of ammonia as a home product obtainable on a large scale, they worked out the conditions of temperature, concentration, nature of medium, &c., which would result in the maximum formation of nitrates. The most important step they have made is to show that humus, so far from being inhibitive of nitrification, as most organic substances are, is actually favourable, so that peat or turf, which is almost wholly humus, by reason of its great water-absorbing powers and the large surface it offers, becomes the best of all substrata for nitrification, if it is also supplied with a sufficiency of carbonate of lime, and a vigorous growth of the necessary organisms is first established in it.

As a final result of their investigations, MM. Müntz and Lainé show that the optimum production of nitrates is attained when the ammoniacal liquids percolate through successive beds prepared of finely divided peat mixed with carbonate of lime. It is impossible to begin with a concentrated solution of the sulphate of ammonia, 7½ grams per litre being about the optimum when the "nitrière" is in full activity; but after this liquid has been nitrified, successive additions of fresh sulphate of ammonia can be made, and the liquid put through another bed until a concentration of 47 grams of calcium nitrate per litre is reached, a figure which is still well below the limit of 20 per cent. at which nitrification ceases. With such an installation the authors expect a daily formation of 7½ kilos. of nitrate of calcium per metre cube of turf, which represents an extraordinary advance upon the old nitre beds producing 5 kilos. of potassium nitrate per metre cube in two years.

Of course, the process at present is not within the domain of practical politics; ammoniacal nitrogen has practically the same market value as the nitric nitrogen produced, so that the labour expended and the cost of evaporating the final solution would all be wasted; but, as the authors began by pointing out, the occasion may yet arise when a country without command of the sea may require to manufacture its own nitrates. Then "nitrières" could be established by peat bog to convert into nitrates the ammonia which could be distilled out of the peat. The only doubt that occurs to us is what opening the recent electrical methods of making nitrates from atmospheric nitrogen will even then leave for such a process.

A. D. H.

PROMINENCE AND CORONAL STRUCTURE.¹

ANYONE who has studied the forms of the corona observed at different eclipses knows that these forms change from time to time, going through phases which are more or less repeated every eleven or twelve years according to the solar activity. I have previously indicated (*Monthly Notices, R.A.S.*, vol. lxiii., No. 8, p. 481) that there is reason to believe that these changes of shape depend, not on sun-spot action, but on the position and percentage frequency of solar prominences, so that when prominences are most frequent, either near the solar poles or equator, the coronal streamers follow suit.

Prominences can now be observed and photographed every day, but coronal streamers and the lower corona can only as yet be seen during eclipses. From photographs taken during eclipses, it is difficult always to associate certain streamers with prominences, and indeed this should be the case. The reason for this is that prominences are only seen on the limb of the sun that is in profile in such photographs, while streamers may be observed in perspective in addition. The base of a large streamer need not necessarily, therefore, be situated on the solar limb.

It is, I think, now generally acknowledged that a study of eclipse photographs has shown that there is an intimate association (a) between streamers and the lower corona, and (b) between the lower corona and prominences. The more, therefore, the form of the lower corona can be attributed to prominence action the more the streamers will depend on prominence activity.

In the eclipses of 1898, 1901, and 1905 "arched" or "envelope" structures were photographed. Thus Prof. Dyson, in describing the series of three arches he photographed in 1901, said, "A very remarkable arch in the corona. Round the prominence three separate arches are shown, one inside the other. . . They have the appearance of cloud over an eruption."

Again, the Astronomer Royal, referring to his photographs of the 1905 eclipse, writes, "very bright prominence associated with oval rings and arched structure in the corona."

The question arises, are these "arched" forms composed of prominence or coronal material? Photographs taken with prismatic cameras during these eclipses might answer this question, since they are capable of recording, in monochromatic light, images of the sun's surroundings.

An examination of such photographs taken by the Solar Physics Observatory's expedition had, however, shown no indication of any such "arch" systems, but it is quite possible that the comparative faintness of the objects in question and the insufficient lengths of exposure given may account for their absence in the records.

So far as I am aware, no such series of "arches" has been photographed except during the eclipses above mentioned, so that whether the material composing the arches is "coronal" or "prominence" is still undecided.

Although the routine work with the spectroheliograph of the Solar Physics Observatory since the year 1904 has been to secure, daily if possible, photographs of the sun's disc and limb in the wavelength of the "K" line of calcium, it was not until July 17 of last year that a photograph was obtained which presented a magnificent series of "arches."

¹ Abstract of a paper read before the Royal Society on January 16 (Roy. Soc. Proc., Series A, vol. lxxx., No. A 537, pp. 178-182).

The disturbed area on the sun was situated near the south pole in the eastern quadrant. Two photographs of this region were secured, one at 3h. 14m. p.m., G.M.T., and the other at 3h. 50m. p.m., G.M.T. In the first (see Fig. 1) the arches are clearly visible and complete, but in the second they are less discernible and partially broken up, in spite of the fact that the second photograph had the better exposure.

The most conspicuous feature of the whole disturbed area, shown in Fig. 1, is the series of three concentric arches, which nearly reach down to the chromosphere. Their heights, as measured from the chromosphere, are $1'5$, $2'9$, and $3'6$. The radii of the arches photographed and measured by Prof. Dyson for the 1901 eclipse were $1'2$, $2'4$, and $3'7$. It will thus be seen that both are of about the same order of magnitude.

It will be noticed further that the intensity of the arches is not uniform; thus the outside one has five points of increased intensity, while the next in order has three such maximum points. On the eastern side of these arches there is another distinct semi-oval which intersects two of the three main arches. On the southern side are some minor projections from the chromosphere which by their curvature seem to indicate that they form part of the whole disturbance.

The magnitude of this very active region will be

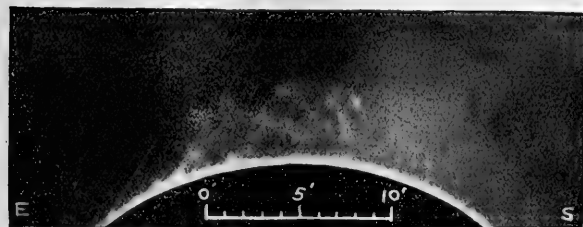

FIG. 1.—A prominence in the form of "arches" photographed in "K" light on July 17, 1907, at the Solar Physics Observatory, South Kensington.

more readily grasped when it is stated that the extreme portions were separated by $12'7$ and the highest point from the chromosphere measured $3'6$. Thus the breadth extended 353,000 miles, or more than three-quarters of a solar radius, and the height was about 101,600 miles.

It is interesting to note that there is apparently no large prominence underlying these envelopes, but whether there is one just on the near or far side of the limb cannot be stated.

The above photograph demonstrates that "arches" similar in form and magnitude to those secured during eclipses have now been photographed in the light of calcium vapour. This indicates that at any rate one of the components of the material of which they are built up is calcium. As the spectrum of the corona has no line at this wave-length, the deduction may be made that the arches photographed during eclipses are most probably of "prominence" and not of "coronal" material.

We have, therefore, another link in the chain to show the dependence of the form of the corona on prominence activity.

Since the above paper was communicated to the Royal Society, M. A. Hansky has published the results of his discussion of the corona pictures

he secured at the total solar eclipse of August, 1905, and one of the conclusions which he has arrived at is as follows:—

"Il est très probable que la forme et la direction des rayons coronaux dépendent de la form et la direction des protubérances au-dessus desquelles ils se trouvent" (*Mitt. d. Nikolai-Hauptsternwarte zu Pulkowa*, Band ii., 1907, No. 19, p. 118).

WILLIAM J. S. LOCKYER.

DR. A. W. HOWITT, C.M.G.

BY the death of Dr. A. W. Howitt, recorded in NATURE of March 12 (p. 443), a link has snapped between the old days of the perilous exploration of Australia and the detailed scientific investigations of the present day. As early as 1858, Mr. Howitt's knowledge of bush-craft was such that a syndicate in Melbourne appointed him head of an expedition to acquire a tract of the "Promised Land" in Central Australia, of the existence of which Warburton had recently confirmed the report of Stuart. In 1860 he conducted a prospecting expedition in Gippsland. The following year he was selected to lead a party in search of the ill-fated Burke and Wills Expedition, of which John King, the last survivor, was rescued; later Mr. Howitt penetrated into the Great Stony Desert. Thus for many years Mr. Howitt had a wide personal acquaintance with the physical characters of southern and south-eastern Australia. On his numerous expeditions and journeys he came into close and friendly contact with the natives, some of whom were in a condition of complete savagery, and, later on, circumstances enabled him to acquire considerable influence over tribes in south-east Australia, so much so that he was even permitted to be present at their sacred ceremonies.

In 1873, Mr. Howitt joined the late Dr. Lorimer Fison in investigating the classificatory system of relationship which obtains among certain tribes, as well as the tribal class system and the rules of marriage and descent connected therewith. These investigations were published in 1880 in their memorable book, "Kamilaroi and Kurnai," which laid the foundations of a truer conception of Australian sociology than was previously possible. Of similar joint authorship were papers "From Mother-right to Father-right" and "On the Deme and the Horde," in the Journal of the Anthropological Institute (1882, 1884). In the same journal, from 1883 to 1908, Mr. Howitt published a series of papers of great value dealing with Australian sociology, initiation ceremonies, religion, and other phases of native customs and beliefs. In the production of these Mr. Howitt was assisted by some sixty correspondents from various parts of the continent; these informants were subjected to continued questioning, which elicited more detailed knowledge. Mr. Howitt also published in the annual report of the Australasian Association for the Advancement of Science (1890, 1891, 1901), papers "On the Use of Gesture Language in Australian Tribes," "Anthropology in Australia," and "On Trade Centres in Australian Tribes." On the occasion of the meeting of the British Association in Cambridge in 1904, the University of Cambridge presented Mr. Howitt with the honorary degree of Doctor in Science, in recognition of his ethnological investiga-

tions. Later in the same year Dr. Howitt published, with Messrs. Macmillan and Co., Ltd., his great work on "The Native Tribes of South-east Australia," in which is embodied his life's work in ethnology. By far the greater part of the materials was collected and recorded before 1886. Since then the native tribes have more or less died out, and in the older settlements of south-eastern Australia the tribal remnants have now almost lost the knowledge of the beliefs and customs of their fathers. Fortunately, Dr. Howitt began to observe and collect information before it was too late, but even then much had disappeared.

Dr. Howitt's book contains a great mass of information concerning numerous tribes, and thus it serves as an invaluable storehouse for students, but it is more than this, as it embodies the mature opinions of the father of Australian ethnology, who, by his kindly and sympathetic nature, was able to gain and retain the confidence of his native friends. The opinion of a man of such prolonged and varied experience in the field, combined with the knowledge of what others had collected, must always carry weight. The collecting and recording of complete ethnological data are naturally matters of first importance, but of even greater interest is the true appreciation of the ideas which underlie the actions of men. He who has lived among the people he describes should be the best interpreter of their ideas and ideals, and in these matters we are not likely to find a surer guide than the genial explorer and student whose death will be deplored by ethnologists all the world over.

A. C. HADDON.

NOTES.

THE astronomical section of the Paris Academy of Sciences has elected M. Maurice Hamy, of the Paris Observatory, to succeed the late Dr. Janssen as a member of that section of the academy. M. Hamy entered the observatory in 1884, and was awarded the Lalande prize in 1895.

THE Paris correspondent of the *Times* states that the Academy of Sciences has appointed a committee, composed of MM. Becquerel, Bouquet de la Grye, and Poincaré, to consider a suggestion by M. Bouquet de la Grye concerning the application of wireless telegraphy to the problem of the determination of longitude at sea. The idea is to utilise the wireless telegraphy station of the Eiffel Tower in order to send, for instance, every night at midnight a Hertzian signal giving the time of the meridian of Paris. M. Bouquet de la Grye thinks, indeed, that if a wireless telegraphy station were established at the Peak of Teneriffe signals could be detected completely around the earth.

THE next International Congress of Archaeology will be held at Cairo in 1909.

FOR the purpose of discussing subjects of interest to those concerned in the work of museums, art galleries, and kindred institutions, a conference of members of the Museums Association and others interested will be held in the Harris Free Public Library and Museum, Preston, on the afternoon of Saturday, April 11.

THE twenty-fourth annual meeting of the Society of Dyes and Colourists will be held on April 3, at 4.30 p.m., at the Technical College, Bradford. The president, Prof. R. Meldola, F.R.S., will deliver his presidential address on "The Founding of the Coal-tar Colour Industry." The first awards of the Perkin medal will be made to Profs.

C. Graebe and C. Liebermann for their synthesis of alizarin. On the evening of the same day the members of the society will dine together at the Great Northern Victoria Hotel, Bradford.

EARTHQUAKE shocks occurred at Mexico City during the evening of March 26, and were felt also at Guanajuato and Rincon. The town of Chilapa, in the State of Guerrero, was destroyed. The disturbances were recorded by Prof. Milne, F.R.S., at Shide, in the Isle of Wight; by Prof. Belar at Laibach, Austria; and by Prof. Michie Smith in southern India, all of whom communicated their observations to the *Daily Mail*. The earthquake is reported to have begun soon after 11 p.m. on March 26, to have reached its maximum at 11.53 p.m., and continued for more than three hours. The shock was felt at St. Thomas, in the West Indies.

WE learn from the April number of *Nature Notes*, the magazine of the Selborne Society, that at last a Bill is to be introduced into Parliament to restrict the importation of birds' skins, and so prevent in some measure the rapid extermination of beautiful birds, of which the egret ("osprey") and birds-of-paradise are typical examples. A short time ago, Lord Avebury, president of the Selborne Society, called together a meeting of representatives of the various learned societies at his house to consider whether legislation ought to be attempted, and this being the general opinion of those present, the main features of a Bill drafted by Mr. James Buckland were adopted for presentation to the societies interested.

EFFORTS are being made to form an Institute of Metals, which it is hoped by the promoters will follow similar lines to the Iron and Steel Institute. The proposed institute is intended to advance the knowledge of non-ferrous metals and their alloys, more especially copper, zinc, tin, aluminium, lead, nickel, silver, and platinum; to form a means of communication between members of the same trade; and to arrange periodical meetings for the purpose of discussing practical and scientific subjects relating to the metallurgy and use of the metals enumerated. A preliminary meeting was held in Manchester on March 11, and was well attended. A representative committee comprising practical men engaged in the industries concerned and men of science was elected, and it was decided to arrange a further meeting in London. This special meeting will, we are informed, be held on June 10 next, at 2.30 p.m., at the Institution of Mechanical Engineers, Westminster. On this occasion the committee will report progress, and it is hoped the proposed institute will be constituted formally. All inquiries should be addressed to Mr. William H. Johnson, c/o Messrs. R. Johnson, Clapham and Morris, Ltd., 24 and 26 Lever Street, Manchester, who is acting for the honorary secretary, Prof. Carpenter, during his indisposition.

IN the March issue of the *Bulletin* of the St. Petersburg Academy, Dr. E. Jäderholm gives a preliminary account of the hydroid polyps collected in the Arctic Ocean north of Siberia by the Russian Polar Expedition of 1900-3, while Dr. Salensky continues his description of the development of the gephyrean worm (mis-called echinoderm on p. 493 of our last issue) *Echiurus*.

THE American white ant (*Termes flavipes*) and the bag-worm (*Thyridopteryx ephemeraciformis*) constitute, respectively, the subjects of two illustrated "Circulars," Nos. 50 and 97, of the U.S. Bureau of Entomology. An excellent account is given in the first of these of the social economy

of the white ant, and the damage inflicted by the species in the Southern United States.

THE existence of an intimate relationship between the fauna of the eastern coast of Arctic North America and that of northern Europe has for some years been admitted by naturalists. Supplementary evidence to the same effect is afforded by a recent study on the part of Mr. J. A. Cushman of minute fresh-water crustaceans from Labrador and Newfoundland, the results of which are published in No. 1589 of the Proceedings of the U.S. National Museum. Cladocera were represented in the collection by seven and the Copopoda by one species, all of which are common to Europe.

THE second part of the new Leipzig journal *Vorträge und Aufsätze über Entwicklungsmechanik der Organismen* is devoted to a paper read by Mr. Jacques Loeb before the International Zoological Congress held at Boston (Mass.) in August last, on the chemical character of the secretions of the reproductive organs. Starting with the axiom that the special prerogative of living organisms is the power of automatic reproduction, the author proceeds to describe the chemical composition of the reproductive elements, and the bearing of this on certain biological theories.

Zeitung für Literatur, Kunst und Wissenschaft for March 15 contains a summary of the results of the Hamburg Expedition to the Magellan Strait in 1892-3, as detailed in a work of three volumes just issued by the Hamburg Museum of Natural History. A feature on which the Hamburgers specially pride themselves is that the expedition was practically "run" by the municipality and inhabitants of their own city, while even the scientific workers are to a great extent their own fellow-citizens. According to the notice in the *Zeitung*, special attention appears to have been directed to the subject of "bipolarity," that is to say, the occurrence of similar types of animal life at the two poles and their absence from almost the whole of the intervening area. The geological and faunistic resemblances of South Africa, South America, and Australia are also referred to, with the remark that most of the common types indicate extremely ancient forms of life.

THE importance—or rather the absolute necessity—of cooperation among workers in different branches of biological research formed the subject of discussion at a meeting of the American Society of Naturalists in December last, in which Profs. Lillie, Trelease, Donaldson, Howell, and Angell took part. The discussion is reported in *extenso* in *Science* of March 5. The first speaker, Prof. Lillie, took for his text the American Marine Biological Laboratory as an example of cooperation, not only among the members of its governing body, but with various other institutions. As it is, several branches of sciences are represented in the laboratory, but it is suggested that it will be necessary to add a chemical section. Prof. Trelease, on the other hand, took his illustrations from the fact that at the present day interest in biology centres on the mechanism of animals and plants, and their relations to environment—factors demanding the cooperation of morphological and physiological research. A further advantage claimed for cooperation is that by its means alone it is possible to discover the most productive and original research-workers.

A PART (vol. iii., No. 4) of the Records of the Botanical Survey of India is assigned to a revision of the Indo-Malayan species of *Cedrela* undertaken by Prof. C.

de Candolle. The author restores to the genus the species separated by some systematists under a genus *Toona*. The columnar receptacle of the flower is noted as a character of systematic value. As it was found difficult to assign specific limits to the specimens ranging round the species *Toona*, the forms are split up into numerous varieties. Of three new species created, *Cedrela Hainesii* is the most notable on account of the staminodes that are present in the flower.

WRITING on the Florida strangling figs, an article intended for the nineteenth annual report of the Missouri Garden, Prof. E. A. Bessey describes the characters of the two indigenous species *Ficus aurea* and *Ficus populnea*. The former commonly, the latter rarely, begins life as an epiphyte; in this connection it was experimentally determined that the seeds of *Ficus aurea* require light for germination. The seeds of *Ficus populnea* show a less marked light requirement. Neither species develops the two distinct types of pistillate flowers known as seed and gall flowers, but larvae are produced if the flowers are visited by ovipositing Blastophagæ; otherwise seeds are formed.

THE early stages of development of the sporangia and the sporocarps of *Azolla* have been carefully studied by Miss W. F. Pfeiffer; the account published in the *Botanical Gazette* (December, 1907) corrects and amplifies previous information on the subject. In all cases a mega-sporangium is formed at an apex, and the wall rising below as an annulus quickly outgrows and encloses the sporangium. The development of the megasporangium is normal up to the formation of eight tetrads. Meanwhile, the microsporangia begin to appear as initial cells on the broad stalk of the megasporangium. At this stage, for reasons undetermined, either the megasporangium develops and the microsporangia cease to grow, or the megasporangium aborts and the microsporangia then develop normally.

MR. L. WRAY contributes to the Journal of the Federated Malay States Museum (vol. ii., No. 2) an account of a Malay varnish that is prepared from the resin obtained by making incisions in the bark of the tree *Garcinia merguensis*. The same writer publishes a short account of a native method of embroidering with gold thread, and a note on an opium substitute favoured by the Malays in some districts. The latter, known as "biak," is made from the leaves of *Mitragyne speciosa*. The dried leaves are powdered and mixed with water to form a decoction, or an extract is made that is smoked like "chandul," the extract of opium. In the same number will be found a hand-list of birds of the Malay Peninsula compiled by Mr. H. C. Robinson.

MR. N. W. THOMAS, in his "Bibliography of Anthropology and Folk-lore," published under the auspices of the Royal Anthropological Institute and the Folk-lore Society, has issued the first number of an annual series which will be indispensable to all students of the subjects with which it deals. His bibliography includes papers and articles in no fewer than 165 publications—proceedings of learned societies, magazines, and other ephemeral literature. In subsequent issues we may hope for a more full analysis of the papers with which the compiler deals. But, as it stands, this pamphlet, which is provided with excellent indexes, serves a distinctly useful purpose.

LAWYERS in India have long been aware that, besides what may be called the official or sacerdotal view of law contained in the Institutes of Manu and other codes of

the same kind, there is a vast mass of local and tribal usage which is independent of, and in many cases directly opposed to, the legislation of the Brahmans. The powerful tribal organisation in the Punjab has made the conflict between these two bodies of law more obvious than in other parts of the Empire. The materials for a study of the subject are voluminous and complex, and Mr. H. A. Rose, the superintendent of the Ethnographical Survey, has done useful service in codifying the district reports in his recently issued "Compendium of the Punjab Customary Law." He divides his subject into three chapters—marriage, inheritance, alienation—and in connection with such subjects as endogamy, exogamy, polyandry, and polygamy he has collected a mass of curious facts which will be interesting to anthropologists, particularly as they represent the usages of a very primitive type of tribal society.

MR. H. WARTH sends us a photograph, here reproduced, representing a method in use in south Germany for producing ice from pure water in winter. The photograph was taken last January in Balingen (Württemberg). The illustration shows a large wooden framework in two storeys, 6 metres square and 6 metres high. Each storey is covered with a floor of eighteen parallel beams, in the

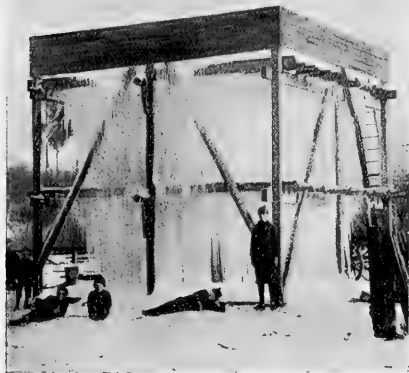

Production of large Icicles.

centre of which a tube, encased in wood, rises beyond the upper floor. This tube is connected with the water-main, and the water issues through a rotating disc, which sends a moving spray on the beams. As the water drops from the beams icicles are formed, which reach the middle floor and finally the ground. The volume of water is regulated according to the temperature of the air, which may vary between -3° C. and -18° C. During low temperature 20 cubic metres of ice may be formed in one night. As the ice retains the shape of isolated columns, it is easily broken up and removed. The ice is then stored for use in summer.

In the Transactions of the South African Philosophical Society of December, 1907, Mr. J. R. Sutton, of Kenilworth (Kimberley), discusses the question of the supposed cloud-dispersing power of the full moon. From observations of the state of the night sky at Potsdam from January, 1894, to June, 1900 (*Met. Zeits.*, May, 1907), Herr

Meissner found no such dispersing power, but a minimum amount of cloud about the time of new moon and a maximum shortly after full. Mr. Sutton thinks that if there be no lunar influence whatever upon the clouds something like Meissner's result might be expected, as the moonlight makes clouds visible (see Schmid's "Lehrbuch d. Met.," 1860, p. 681). At Kenilworth Mr. Sutton finds that cirrus and cirro-stratus appear to dissolve at sunset, but the rising moon makes them plainly visible again. The 8h. p.m. observations taken between January, 1900, and January, 1907, show considerably more cloud between the third and eighteenth lunar day than between the eighteenth and third. Dr. Shaw's interesting paper, "La Lune mange les Nuages" (*Quart. Journ. Roy. Met. Soc.*, April, 1902), shows that any diminution of a floating cloud is due to evaporation by loss of heat, and that "any effect of direct radiation from the moon may be quite properly disregarded."

THE Survey Department of the Egyptian Ministry of Finance has issued, as a pamphlet of thirty-eight pages with thirteen index maps, a list of maps, plans, and publications published up to December 31, 1907. The list includes town maps, cadastral maps, topographical maps of Egypt, special maps, and maps of the different provinces.

PROF. E. GUARINI has published a pamphlet (Paris, 1908) on the resources of Peru. The mineral resources include many rich deposits of gold, silver, copper, and iron ores, which are at present unworked owing to lack of economical methods of transport. The author believes that by the introduction of electric-power transmission and electric smelting, Peru might rank amongst the leading industrial States of the world.

THE question of handling materials in industrial plants is one continually presenting itself to owners and engineers for proper solution, and some striking illustrations showing the remarkable progress recently made in America in economical material-handling equipments are given by Mr. Werner Boecklin in the *Engineering Magazine* (vol. xxxiv., No. 6). The depreciation of such equipments is necessarily high, but in the majority of cases an increase in the first cost, which will materially decrease this charge, is warranted. In the same issue Mr. T. Kennard Thomson describes the construction of hoisting machinery for the handling of materials. He shows that here, as elsewhere in the domain of modern enterprise, economy in unit costs and maximum of output can be secured only where intelligent use is made of the mechanical facilities afforded for the handling of material.

THE application of the camera as an adjunct to topographical mapping began practically with its invention, and it has been employed with varying success since that time. An interesting development is described in the bi-monthly Bulletin of the American Institute of Mining Engineers (1908, No. 19) by Mr. C. W. Wright, who has successfully employed in the field a panoramic camera taking a 5-inch by 12-inch view, including an angle of 140° . The plotting of a map from the views taken by the phototheodolite is a tedious process, and the office work is many times greater than that required for the same amount of mapping by the panoramic camera.

WITH the view of ascertaining whether the results of recent chemical investigations would be of value in lessening the amount of evaporator scale formed in the sugar mills of Hawaii, an elaborate series of experiments was carried out by Mr. S. S. Peck, and the results are published in Bulletin No. 21 of the Hawaiian Sugar Planters

Association (Honolulu, 1908). While the results offer no precise solution to this problem, they explain some of the phenomena of scale formation, and contain much of interest to other investigators, practical and theoretical, of this question, perhaps giving them a clue which will lead to the discovery of a successful method of treating the juice of the cane which will inhibit to some extent the formation of scale during evaporation.

MR. W. GALLATLY has published (Cambridge: Elijah Johnson, 30 Trinity Street) a pamphlet on the nine-point circle, consisting of a collection of short notes reprinted from the *Mathematical Gazette* and other sources. Most of the notes deal with analytical rather than geometrical properties associated with a triangle and the circle in question.

In the Proceedings of the American Academy of Arts and Sciences, xliii., 8, Messrs. C. R. Sanger and O. F. Black discuss the quantitative determination of arsenic by the Gutzeit method. They find that consistent results can be obtained, and the main difficulties avoided, by allowing the arsenic deposit to travel along a strip of paper, and by sensitising this with mercuric chloride in preference to silver nitrate.

In the Proceedings of the Tokyo Mathemato-Physical Society (January), K. Aichi discusses the capacity of nearly spherical electrical conductors. The property, obvious from the general principles of the theory of maxima and minima, that the capacity of a nearly spherical conductor is, to the first order of small quantities, equal to that of a spherical conductor of equal area, is deduced from analytical formulæ.

In *Engineering* of March 27 illustrations are given of the new plant of the Staveley Ironworks, Chesterfield, an undertaking with a record of two centuries. The new works are of great interest, not because of any distinctive departure, but because great discrimination has been exercised in weighing the relative merits of different systems in order that the many mechanical features in the complete equipment should harmonise with the aim to ensure efficiency.

THE application of electricity is fast revolutionising many industries, and an interesting application in the chemical industry is described in the *Journal of the Franklin Institute* by Mr. E. R. Taylor, who gives an account of the process and apparatus for the production in the electric furnace of carbon bisulphide, the manufacture of which in retorts is one of the most disagreeable of manufactures. The furnace used is 10 feet in diameter and 20 feet high, and will produce 5000 lb. per twenty-four hours with economy and satisfaction. Two electrodes only are provided. The market for carbon bisulphide is a limited one, and no larger furnace than those now in use would be justified under present conditions. But were the market for carbon bisulphide as large and as regular as that for pig iron, the size of the furnace need only be limited by market requirements and the amount of electricity available.

UNDER the title "Two Oxford Physiologists" (Clarendon Press, Oxford, price 1s.), Prof. Francis Gotch has published an address, delivered before the Oxford University extension summer meeting of last year, which deals with the life and work of Richard Lower (1631-1691) and John Mayow (1643-1679). The address contains an admirable account of the work of Lower, who is best known as being the first to carry out the transfusion of blood from

one animal to another, and of Mayow, who first recognised the true nature of respiration, and whose "medico-physical works" have just been translated from Latin into English (*NATURE*, vol. lxxvii., p. 339). Prof. Gotch's eloquent address has an especial interest for the general reader in so far as it throws a clear light on the conditions under which scientific work was performed in the seventeenth century.

WE have received a reprint of a lecture by Prof. Stéphane Leduc on "Diffusion and Osmosis" delivered before the meeting held at Rheims in 1907 of the French Association for the Advancement of Science. Certain remarkable experiments are described dealing with the formation and properties of the so-called "waves of diffusion"; the phenomena dealt with, although evidently due to the transmission of material particles, are accompanied by effects entirely similar to those produced by wave motion, especially in so far as they show interference and diffraction. It is stated also that by means of diffusion under certain chosen conditions, using merely solutions of different concentration coloured with a little Indian ink, the pheno-

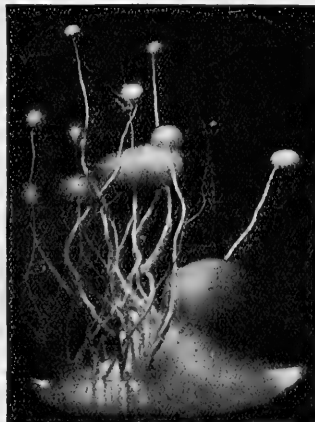

Osmotic growths.

mena of karyokinesis can be reproduced in their proper order and form. Peculiar growths, presenting an appearance similar to that of true vegetable growths, can also be obtained by leaving "seeds," consisting, for example, of copper sulphate mixed with sugar, in an aqueous solution of potassium ferrocyanide saturated with common salt, and containing more or less gelatin and other salts (see accompanying figure). In different experiments growths analogous to roots, rhizomes, stems, leaves, and terminal organs of true plants were obtained, each with a characteristic internal structure depending on the nature of the salts in solution. By these experiments the interesting question is raised, how far the morphology of ordinary plants is determined by purely osmotic phenomena.

In 1869 Bunsen wrote to Sir Henry Roscoe an account of a mysterious explosion caused by touching with the finger some reduced rhodium and iridium. The question of the explosive platinum metals has been taken up several times since then by various investigators, but the exact cause of the explosive properties of these metals has not

been made clear. The explosive material is obtained by treating the zinc alloy of the platinum metal with an acid, and has been regarded as an allotropic modification of the metal. In the *Zeitschrift für physikalische Chemie* for February 25 is an interesting account, by E. Cohen and Th. Strengers, of a long series of experiments on this subject. It was found that the residues from the action of hydrochloric acid upon zinc alloys of rhodium, iridium, ruthenium, and platinum are explosive; palladium and osmium do not furnish explosive residues. Explosive rhodium is now shown to contain both oxygen and hydrogen, and if air is carefully excluded during the removal of the zinc by the acid, the residue is not explosive. The heat evolved during the explosion was measured, and found to be of the same order of magnitude as the heat of combination of the quantities of hydrogen and oxygen actually occluded by the metal. The most probable explanation of the explosive properties of these reduced platinum metals is that the explosion is due to the sudden combination of the occluded hydrogen and oxygen. It was found, however, that in the case of ruthenium an explosive material was obtained even if oxygen was rigorously excluded during the separation from zinc, and this point still remains to be cleared up. In one of the calorimetric measurements, 4 grams of the rhodium destroyed a platinum calorimeter. A photograph of the remains of the calorimeter after the operation is given, and the authors remark that the effect of the explosion of a pound of this material (the quantity Bunsen had in the experiment above mentioned) can be easily imagined. Bunsen, fortunately, escaped with superficial burns on the face and severe burns on the hands.

THE name of Dr. R. W. Stewart should have been given as the author of the books on heat, light, and sound for matriculation candidates reviewed in NATURE of March 26 (p. 482).

MR. H. J. GLAISHER has published the April issue of his catalogue of publishers' remainders; it contains particulars of many scientific and other books which, though in a new condition, are offered at greatly reduced prices.

MESSRS. OLIVER AND BOYD have published a second edition of "Structural and Field Geology for Students of Pure and Applied Science," by Prof. James Geikie, F.R.S. The first edition of this work was reviewed at length in NATURE of July 6, 1905 (vol. lxxii., p. 223), and the present issue differs but little from its predecessor, though some omissions have been supplied and a number of emendations and corrections made.

OUR ASTRONOMICAL COLUMN.

ASTRONOMICAL OCCURRENCES IN APRIL:—

- April 4. 1h. 24m. Venus in conjunction with Moon. Venus $5^{\circ} 52' N.$
 ,, 1h. 28m. Mars in conjunction with Moon. Mars $4^{\circ} 15' N.$
 ,, 3h. 27m. Venus in conjunction with Mars. Venus $1^{\circ} 37' N.$
 9. 10h. 55m. Jupiter in conjunction with Moon. Jupiter $1^{\circ} 21' S.$
 11. 11h. 56m. Minimum of Algol (β Persei).
 17. 8h. 45m. Minimum of Algol (β Persei).
 19. 22. Epoch of April Meteors (Radiant $27^{\circ} 1' + 33^{\circ}$).
 20. Venus. Illuminated portion of disc = 0.540 .
 3h. 12m. Uranus in conjunction with Moon. Uranus $0^{\circ} 27' N.$
 24. 4h. 45m. to 5h. 27m. Transit of Jupiter's Sat. III. (Ganymede).
 29. 7h. Venus at maximum elongation ($45^{\circ} 37' E.$).

NO. 2005, VOL. 77]

COMET 1907 II.—We have received an abstract of a paper read by Prof. E. Weiss before the Vienna Academy of Sciences on February 6, in which the author directs attention to the striking similarity of the orbit of comet 1907 II. to that of the comet of 1742. It appears probable that they refer to the same body, having a period of 165 years. From the fact that the earth passes very near to the ascending node of the cometary orbit towards the end of March, Prof. Weiss expects that a fairly rich meteor shower, from a radiant at $\alpha = 307^{\circ}.6$, $\delta = -60^{\circ}.7$, should be observed in the southern hemisphere.

THE PRESIDENT OF THE ASTROGRAPHIC CONGRESS.—At the request of several members of the permanent committee of the Astrographic Congress, Sir David Gill has, we understand, proposed to the permanent committee that M. Baillaud, the new director of the Paris Observatory, should be elected president of the international congress in succession to the late M. Loewy. Remembering the important part played by France in the labours expended on the Carte du Ciel, the generous support of the Institute of France in the publication of the committee's reports, and the great and successful efforts of Admiral Mouchez, M. Tisserand, and M. Loewy in the furtherance of the work, it is almost as a matter of course that the director of the Paris Observatory should be elected to fill the important position of president of the international committee.

THE HELIUM, D₃, LINE IN THE SOLAR SPECTRUM.—In No. 394 (March, p. 133) of the *Observatory*, Captain Daunt continues the discussion as to the presence of D₃ as a dark line in the solar spectrum, raised by the photographs taken at Kodaikanal by Mr. Nagaraja last year, and comes to the conclusion that the fine dark line shown on the photographs is not an absorption effect of D₃ at all. The main objection raised by Captain Daunt is that the fine dark line on the photographs runs right across the spectrum, and is slightly widened over the spot, whereas, according to his own and to Mr. Buss's observations, the helium absorption line is generally very broken and patchy, and has never been seen over the spot itself; it always appears in the faculae areas surrounding the spot.

TWO REMARKABLE SPECTROSCOPIC BINARIES.—In a note published in the *Observatory* (No. 394, p. 139, March) Mr. Gore shows that two spectroscopic binaries, a Carinae and a Pavonis, recently discovered at the Lick Observatory, must have remarkably small masses. In the case of the former, if the inclination of the orbit be 90° , the mass is but 0.007 of the sun's mass, and if the inclination is 30° this value is only increased to 0.056. The corresponding mass values for a Pavonis are 0.00047 and 0.0038 respectively, and in this case the result is more remarkable still, for a Pavonis is a brighter star, mag. 2.12; its spectrum is of the Orion type. Mr. Gore suggests that both these stars are probably near our system, and an effort should be made to determine their parallaxes.

VARIATION IN THE RADIAL VELOCITY OF β URSAE MAJORIS.—In No. 4239 of the *Astronomische Nachrichten* Dr. H. Ludendorff announces that plates taken at Potsdam show the radial velocity of β URSAE MAJORIS to be variable. The values given range from -6 km. (March 27, 1904) to -26 km. (April 28, 1905), and in a footnote it is stated that later observations show the period to be twenty-seven days.

DR. NORDMANN'S VARIABLE STAR OBSERVATIONS.—Following up the researches mentioned in these columns last week (p. 497), Dr. Charles Nordmann has obtained equally striking results from observations of β LYRAE and β CEPHEI. In these cases the epochs of maxima and minima, as observed through the coloured screens, agreed with the ephemerides, but the amplitude and form of the light-curves vary with the region of the spectrum observed. Thus for β LYRAE the difference between the principal maximum and minimum amounts to 0.66 magnitude with the red, 0.04 magnitude with the green, and 1.34 magnitude with the blue screen. The differences between the two principal maxima vary from 0.3 magnitude with the blue to zero with the red screen, and it is shown that this star emits a greater proportion of the less refrangible rays at the principal than at the secondary minimum. Similar results accrue from the observations of β CEPHEI (*Comptes rendus*, No. 10, p. 518, March 9).

THE NATIONAL PHYSICAL LABORATORY
DURING 1907.

THE report for 1907 of the National Physical Laboratory, presented to the general board on the occasion of the annual meeting and inspection of the laboratory on March 20, contains abundant evidence of the rapid growth and extension of its activities during the past few years, as well as of the usefulness and importance of the research work which such an institution is able to undertake. Following closely upon the report of the Treasury Committee, which has done valuable service, both to the laboratory and to the public, in defining more precisely the limits to be set and the conditions to be observed in regard to the acceptance of certain classes of test work, this account of the past year's work affords conclusive evidence that the organisation of special departments for the verification of instruments and examination of materials need be no hindrance to the concurrent prosecution of those researches which constitute the most important part of the laboratory's work.

It is interesting to note the changes effected since the

opening of the laboratory in 1901. Apart from the observatory department at Richmond, the laboratory originally comprised a physics department at Bushy House and an engineering department housed in an adjoining building of two bays. At the present time the accommodation afforded in Bushy House is supplemented by that of three other buildings, together covering an area at least double that of Bushy House itself, in addition to a smaller building mainly devoted to the test work for the Indian Government, transferred to the laboratory from Coopers Hill, and a special building erected for the War Office standard leading screw lathe. Of the three larger buildings, the engineering building is now nearly doubled in size; the building for electrotechnics and photometry was completed in 1905, and considerable progress has been made with its equipment, which is described in a special appendix to the report, referred to below; while the building for metrology has been more recently erected, and the transference to it of the comparators and apparatus for measurements of length is only now being begun. One special feature of the metrology building is a long passage arranged for the verification of 50-metre surveying tapes and wires, whether on the flat or in catenary.

Of general public as well as of special scientific interest is the completion of the new magnetic observatory at Eskdalemuir, in Dumfriesshire. Primarily intended for the resumption of the magnetic work interrupted at Kew by the coming of the electric tram, it will be equipped generally with the recording and other apparatus necessary to a first-class meteorological station, and will maintain a close connection with its parent institution at Richmond. Dr. Chree's admirable work in the analysis and interpretation of the Kew records will thus be continued

and extended. Eskdalemuir is situated towards the head of the Esk valley, some eighteen miles from Lockerbie on the Caledonian, and from Langholm on the North British Railway, sufficiently far from the nearest point of either line to be secure from magnetic disturbance. The locality promises to be no less free from social perturbations, and the relief measures to be adopted in the event of a severe winter will no doubt engage the attention of the committee at an early date. Mr. G. W. Walker, of Trinity College, Cambridge, and Glasgow University, is the first superintendent.

Among other matters of general interest, one or two branches of work recently undertaken by the laboratory may be referred to shortly. The transference to the laboratory of the Indian Government test work has led to the formation of a new department, of which Mr. Rosenhain is superintendent. The equipment of the new building in which the work is carried out has been systematically planned with the view of securing ease and rapidity of working; a description of the arrangements and of the methods of analysis employed is given in the report of the department.



FIG. 1.—General view of large bay of Electrotechnical Building, looking east.

The testing of taximeters, undertaken for the Commissioner of Police, has aroused a good deal of public attention. The tests applied consist of an exhaustive examination both in the laboratory and on the road of one instrument of a type, and of its mechanism, and of a simpler verification of the accuracy of each individual instrument. The tests are carried out at the laboratory, but a building has been erected in the Lambeth Road for the reception of taximeters for re-examination after use.

The testing of glow-lamps under the specification issued by the Engineering Standards Committee may also be mentioned here. The Lamp-testing Bureau of New York is responsible for reporting annually on some 13,000,000 lamps, to the benefit alike of the manufacturer and the consumer. Indications are not wanting of a demand for such tests in this country; increased facilities for the work are being provided in the photometry department.

Turning now to research, the papers published during the year include some of the most important work carried out by the laboratory. Foremost among these must be mentioned the three papers on the fundamental electrical

units, for which—in conjunction, as regards some parts of the work, with Prof. Ayrton, Mr. Mather, and Dr. Lorentz—Mr. F. E. Smith is responsible, and which, with his earlier paper on mercury resistance standards, embody the results of the work of the electrical standards department from the foundation of the laboratory. We shall, no doubt, have occasion to refer more particularly to these three papers in dealing with the "Collected Researches" of the laboratory, vols. iii. and iv. of which are now ready for issue. The ampere balance, planned originally by Viriamu Jones and Ayrton, the electrical part of which was constructed at the laboratory, with such modifications of the original design as experience showed to be necessary, under Mr. Smith's supervision, has given results "far exceeding that secured in any absolute determination of any electrical unit. . . . The balance was intended to give the ampere to 1 part in 10,000, but about 1 part in 50,000 appears to have been attained. A little uncertainty exists as to the value of g and the axial length of the coils; the latter uncertainty may shortly be removed" (by the construction of new coils).

The work on the comparison of various forms of silver

at the forefront of the institutions engaged in this work. The construction of the Lorentz apparatus, to be presented to the laboratory by the Drapers' Company, has been already commenced, and may perhaps be completed within the current year.

The research work of other departments must be dealt with more shortly. Mr. Campbell has published a valuable series of papers on mutual inductances: construction of standards, and methods of measurement. These latter include the use of a novel form of vibration galvanometer. Dr. Harker's high-temperature work has been delayed by his illness, but a new type of high-temperature furnace has been devised which promises well for the uniform heating of fairly large objects to about 2500° C. In the metrology department much time has been devoted to the development of methods of measurement of screws, and a 4-metre standard bar has been divided and calibrated. Mr. Hunter, in the optical department, has devised a method of considerable interest for the measurement of definition, more especially of photographic lenses. In the electrotechnics department a research on the dielectric resistance of insulating materials, undertaken for the

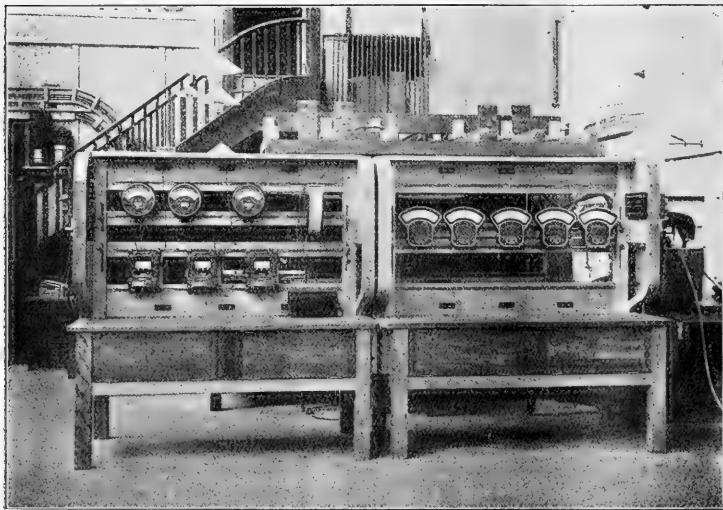

FIG. 2.—General view of one of the instrument-testing stations.

voltmeter has led to results of the same order of accuracy. Mr. Smith has shown that under specified conditions all the different types of voltmeter experimented with give identical results for the electrochemical equivalent to within 2 parts in 100,000. In a suggested specification for the international ampere the Rayleigh form is recommended as the easiest to erect.

The paper on the Weston cadmium cell summarises the results of all the observations made at the National Physical Laboratory, and establishes the reproducibility and constancy of the cell. The results of comparisons between American, French, German, and English cells are given in the report, and show that standard cadmium cells can be set up by different experimenters with different results to agree within a few parts in 100,000.

The results obtained in these researches and in those previously carried on in the standardising institutions at Washington, Paris, and Berlin should make the way for the International Conference on Electrical Units to be held in London probably this year. Mr. Smith is to be congratulated on having placed the laboratory in the

position of being able to apply the results of impact testing machine, and the elastic limits of material under alternating stress.

In the new department for metallurgy Mr. Rosenhain has been very active, and at least three researches of first-rate importance were in progress during the year under his direction. The most interesting is perhaps the investigation of the alloys of aluminium, copper, and manganese, in continuation of the work carried out by Dr. Carpenter on the aluminium-copper alloys, which appears in vol. iii. of the "Collected Researches." For the purpose of the metallurgical research an ultra-violet microscopic outfit has been installed for obtaining photomicrographs at magnifications up to 3600 diameters.

The report is followed by an appendix, which gives some details as to the equipment of the electrotechnics laboratory (including the department for photometry). Much yet remains to be done to complete the equipment of this building, but the arrangements have been planned with the view of meeting the demands which are likely to arise, and the account given is of no little interest and

undertaken for the Engineering Standards Committee, has been delayed by the failure of the 100,000-volt transformer under construction.

In the engineering department, Dr. Stanton has completed some important researches. The wind-pressure work has established interesting results as regards the relative pressures on large and small plates, which receive remarkable confirmation from the experiments of M. Eiffel. The comparison of open-air results on large models with those obtained earlier for small models shows that the values for large surfaces in the open can be inferred with accuracy from observations in the laboratory. Other researches carried out deal with the resistance of materials under re-

utility. The chief feature is probably the careful provision made for the distribution of voltage and current about the building, the utmost flexibility in this respect being essential for the varied purposes of test and research.

The building—mainly on one floor—comprises one large bay (Fig. 1) for machines and alternating current test work, two parallel rooms of half the area for heavier test work and resistance and direct-current work respectively, with offices and workshops beyond. The photometry section, on two floors, runs at right angles to these on the east. Above are the rooms for the photometric measurements, with a 90-foot track for arc-lamp work; the ground floor provides accommodation for life tests,

approximately circular scales 26 feet in length, with an accuracy of 1 part in 10,000. Outside the building, on the opposite side of the main bay, is a small, entirely detached, fire-proof high-tension transformer house, to be occupied by the 100,000-volt transformer, with the aid of which it is proposed that Mr. Rayner should continue the valuable researches on insulating materials already published. Twelve-inch ducts carry the high-tension current into the large bay.

Fig. 2 gives a general view of an instrument testing station—or testing bench—at the east end of the large bay (see Fig. 1). The bench part of the stand in front is arranged as a cupboard with glass top, in which instruments of horizontal type can be tested at any temperature; for other purposes the glass can be covered with teak lids. The back compartment contains heating lamps and a fan for carrying the heated air to any part of the station, the upper part being arranged so that it can be covered with a thin celluloid cover. Above the station may be seen the main heavy current leads. In Fig. 3 are shown the water-cooled regulating resistances employed for heavy current work, of 6000 amperes capacity.

The resistance room, in charge of Mr. Melsom, contains arrangements for all high and low resistance work, except that on ultimate standards; for tests on cables, insulation testing sets, &c., and for dry-cell testing. For accommodating accumulators under test a small building has been erected outside the north wall.

Mr. Paterson and his collaborators have given the utmost attention to all detail throughout the building, the benefit of which will doubtless be felt as the work increases.

Although the development of the laboratory since 1901 has been rapid, it is clear that even now it has but barely reached its most active period of growth. The need and the value of the services it can render become progressively more apparent, and Dr. Glazebrook's able administration and untiring energy may be expected to produce even greater, if perhaps not so obvious, advances in the next seven years.

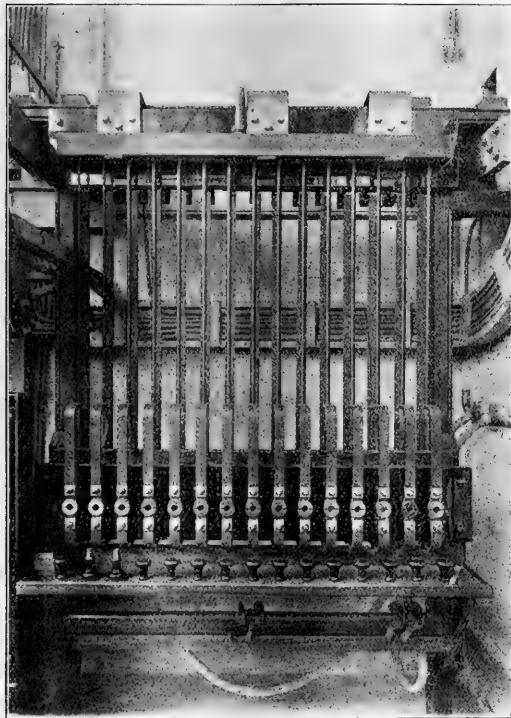

FIG. 3.—Water cooled regulating resistances—capacity 6000 amperes.

and is already largely occupied with the specially designed life-test racks necessary to cope with the probable demand to which reference has been already made. The results of the work on light standards at the laboratory since 1903 were laid before the Institution of Electrical Engineers by Mr. Paterson in December, 1906, in a paper which gained an institution premium, and much time has been devoted during 1907 to work on the pentane standard, while the photometry of differently coloured lights is also receiving attention.

The instruments for alternating current standard work occupy the centre of the main bay (Fig. 1); on the right, under a platform to screen off light, are the two standard electrostatic voltmeters, reading up to 400 volts, on two

the age of fishes. The scales furnish some evidence, but in most cases, at any rate, they are hard to read. The otolith method, on the other hand, is easy, and much more rapid than the scale method.

The otolith shows on its surface a series of concentric rings alternately light and dark, and Reibisch in 1899 found that each light ring represented the growth of the otolith during the summer, while the dark rings represented winter growth. There seems to be no difference in structure in the alternate rings, the different appearance being produced entirely by a difference in the density of the substance. In the light opaque rings the particles are more closely packed, while in the dark more or less transparent rings the particles are farther apart. Since

THE NORTH SEA FISHERIES INVESTIGATIONS.

WHEN the British Government in 1902 undertook to cooperate with other countries bordering on the North Sea in an investigation into the fisheries of that region, it delegated its share of the work in the north to the Scottish Fishery Board and in the south to the Marine Biological Association of the United Kingdom. The latter has now issued its second report upon the work done by its naturalists and hydrographer covering the period 1904-5.

Four papers are included, and the first is by Dr. Wallace on the age and growth-rate of plaice in the southern North Sea, and is the result of the application of a method of determining the age of the fish by the otolith or "ear-stone." Various attempts have been made to determine

Reibisch's discovery of the importance of these rings as an indication of the age of the individual fish, Redecke, Johansen, and Wallace have all independently proved the correctness of his discovery.

In the present paper Dr. Wallace applies the method to determine the rate of growth of the plaice, its distribution in relation to age, and other points of interest with regard to the habits and life of the species.

Previous to the application of this method the only means of getting approximately at the age of the fish was by measuring the length of large numbers of individuals and obtaining a frequency curve, but, as Dr. Wallace points out, this method had many disadvantages which are avoided by the otolith method.

By examination of the otoliths, not only is the average length for any age determined, but also the maximum and minimum lengths are obtained. The only assumption made is that all plaice emerge from the egg on April 1! Since the plaice only spawns once a year, and the spawning season at the most lasts three months, the error, owing to this assumption, is negligible.

Having determined the "age-groups," Dr. Wallace discusses their distribution in the area investigated, and in connection with this is brought out the existence of a "selective migration," that is, the distribution or sorting out of individuals according to size. The larger fish of the year tend to move into deeper water than the smaller. It is not a new observation that large fish are found in deeper water, but age is a factor which has not previously been taken into consideration. At any depth are to be found fish representing the larger ones of a recent year, the average sized ones of an earlier year, and the smaller ones of a still earlier year, and so on, but the bulk of the fish of any one size will belong to one particular year, so that at any given depth we shall find the fish of one particular year dominant.

Although this is the rule up to three or perhaps four years old, these older fish seem to be affected by other factors not yet sufficiently understood, as on apparently similar grounds the average size of the fish may differ considerably.

In discussing the average growth-rate of the plaice in the southern North Sea, Dr. Wallace points out that there is a different average growth-rate in the two sexes, and also that the longevity of the female is greater than that of the male. Up to five years of age the average number of males and females is apparently the same, but after that the males rapidly fall off in numbers, and in plaice of eight years old and upwards 67 per cent. are females. The males arrive at maturity one or even two years earlier than the females, and after seven years practically cease to grow.

We reproduce one of the excellent series of photographs of otoliths taken by Mr. R. A. Todd, representing the right otoliths of twenty plaice. The fish were 27 cm. long, and the majority were four years old, as can be seen from the otoliths, which nearly all show four white rings.

Dr. Wallace's paper is somewhat difficult reading owing to the short paragraphs and frequent interpolation of tables, diagrams, and references. A short summary covering all the ground would, we think, in the circumstances have been specially useful.

Mr. R. A. Todd has continued his researches on the food of fishes, and some most valuable results are brought out by his laborious work. First he notes the fact that the younger fish of every species examined (thirty-four in all) chiefly depend upon crustacea for their sustenance, phipods, cumacea, and decapod larvae forming the chief food supplies.

Secondly, he shows that although in the young fish the distinction between all species may be great, in the adults it is not nearly so keen, except in certain cases. The chief food of all fishes appears to be crustacea, and crustaceans, but a few species also feed upon echinoderms and calcareates as supple-

mentary supplies. Competition is avoided by each species preferring some few particular species, which often seem to form its staple diet.

Mr. Todd's researches have led to some interesting observations as to a fasting period peculiar to one or two Pleuronectidae. It seems that this is connected with the spawning period, as in the salmon, but in the case of the plaice it is chiefly the male which abstains from food, since on the spawning grounds "the greater the excess of ♂ over ♀ the greater the proportion of empty stomachs."

The report upon the plankton of the English Channel, by Dr. L. H. Gough, contains some interesting observations as to the causes of distribution. In spite of the fact that the minute organisms constituting the plankton are primarily dependent for their distribution on the water movements, there are two characteristic classes, the oceanic, found only away from land, and the neritic, found in shallow waters. Salinity was at first supposed to be the determining factor, it being thought that the oceanic forms could not survive in the fresher waters near the coast, but Dr. Gough points out that these forms are capable of withstanding a greater range of salinity than is to be met with in the region explored. The most



Views of the concave (outer) surfaces of right otoliths of twenty-five plaice, mostly with four rings. Magnified about three times.

recent theory to account for this distribution is that the decomposing organic matters in the shallower waters where bottom fauna and flora flourish are poisons to the oceanic species, whereas they are either innocuous to or possibly necessary for the neritic species.

The fourth paper in the report deals with the surface waters of the North Atlantic Ocean south of 60° N. lat. from September, 1904, to December, 1905. Mr. D. J. Matthews explains that the paper is almost entirely descriptive, giving an account of the distribution of surface salinity and temperature over a period of sixteen months. Samples of water have been obtained over a large area through the assistance of the captains of a number of steamers.

Even during the short period covered certain striking facts have been observed as to the movements of the waters. For instance, a distinct waxing and waning of the Labrador current has been detected.

Monthly charts showing temperature and salinity for the whole sixteen months add greatly to the interest of the paper.

The volume forms a valuable contribution to science.
FRANK BALFOUR BROWNE.

*EXTENSIONS AT UNIVERSITY COLLEGE,
LONDON.*

ON Thursday last, March 26, the Chancellor of the University of London, the Earl of Rosebery, visited University College, the occasion being the opening of the new libraries and the south wing after the changes made consequent upon the removal of the boys' school to Hampstead.

The Chancellor on his arrival was met by the Vice-Chancellor (Sir William Collins), Sir Philip Magnus, Lord Reay, Sir Edward Busk, Sir Felix Schuster, Sir Arthur Rücker, Dr. T. Gregory Foster, Dr. Bourne Benson, the deans of the college faculties, and other members of the college committee. After an inspection of the alterations, the Chancellor proceeded to the botanical theatre and gave an address, formally declaring the new libraries and south wing open.

In his address Lord Rosebery said they met on a very interesting occasion, because they met to celebrate the fact that, owing to the removal of University College School, the accommodation of University College itself had been increased by fully one-third, and that therefore it had taken one more gigantic stride onward in its progress as a great centre of university life. To achieve this result great exertions had been made. No less than 276,000l. had been raised by the magnificent bounty of various donors. As a result of these donations there had been found room for scientific departments hitherto inadequately housed. There had been found room for an adequate museum and class-rooms for geology; a biometrical laboratory for research, which enabled Prof. Karl Pearson to continue his experiments in much more advantageous circumstances; a laboratory had been added of national eugenics (owing to the bounty of Mr. Francis Galton) which could not but be of great advantage to that portion of the curriculum. In the school of engineering a museum had been added, and a hydraulic laboratory. In the school of electrical engineering the accommodation had been doubled. The research laboratory of experimental psychology had been lodged in entirely new quarters. The department of hygiene had been greatly enlarged and largely equipped mainly by the generosity of the Chadwick trustees. In the faculty of arts eleven new lecture-rooms had been added. But perhaps the library was the most remarkable feature of the new enlargement. The method of arrangement required notice by everyone who was interested in that subject—a large general library and a series of specialised libraries in enclosed subdivisions which served as conference rooms for teachers and pupils.

Last, but not least, Lord Rosebery alluded to the extra accommodation for the students of the union. He honestly thought that no wiser thing could have been done by the authorities than to make their students feel it not merely a class-room, but a home, and to give them accommodation where they could spend their leisure hours as their elders did in clubs. He had reason to believe that the University College Debating Society was one of the most formidable of those academic parliaments which sometimes invited their seniors to address them on the principle, he thought, on which the Spartans were wont to place a drunken helot in their midst to serve as a melancholy example of what might happen to them if they did not stop in time. He also directed attention to the new recreation grounds and the residential hall at Ealing, which will be ready next October.

This was a record of manifold activities and of splendid beneficence. It inspired certain expectations in those who were interested in the work of University College and of the University of London. There they had a college which yielded to few colleges in the world in its appliances, situated in the midst of the greatest metropolis in the world, educating and rearing hundreds and hundreds of students, the centre of one form of university life in the metropolis. What a long way they were from the old Stinkumalee, as it was derisively called by Theodore Hook. Stinkumalee, he told his young hearers, was the atrocious name that was applied to University College in the days of its youth. Did it not show what an enormous march had been made by that college since the time when it was known by such a nickname as that?

The whole of London at this moment was teeming with

university life. All this life irresistibly was drawn to the University of London. He was sometimes tempted to ask himself if the machinery of their university was adequate to the great strain that was being put upon it by the multiplications of the institutions that were under its fostering care. He sometimes doubted, if they were to undertake new tasks and burdens, whether their constitution was sufficiently elastic to undertake them. They had not all the power that tradition gave of the splendour of antiquity, but they had the advantage of the vigour, the adaptability of extreme youth. They were a new bottle into which new wine could be abundantly poured without risk. He pleaded that University College might not forget its youth, because its youth was its strength, and he thought it well that he should put this consideration before them, because the occasion was not a light one, either in the history of the University or of the College, because the visit of the symbolic head of the University to University College on that occasion emphasised and embodied the alliance between the University and a college which had so lately taken place, and from which he and they all augured such immense advantage in the future.

The thanks of the meeting to the Chancellor were accorded on the motion of the Vice-Chancellor, seconded by Lord Reay (the chairman of the college committee), and supported by the Provost, Dr. T. Gregory Foster. On leaving, Lord Rosebery shortly addressed the students in the cloisters, declaring that they had had good advice poured over them like pots of ointment, like spikenards of eloquence. He would only thank them then to point out that the University in the last resort depended upon the men it turned out. He asked them, and it was his only message for the day, to turn out ladies and gentlemen worthy of the University of London.

In addition to the outline given by Lord Rosebery, we may signalise more in detail the changes in the engineering departments. In general engineering the drawing office has been enlarged and arranged so as to provide separate junior and senior offices controllable from the same demonstrators' boxes. There is accommodation now for 100 students working at the same time. Space has been provided for an engineering museum, the equipment of which has already begun. A small engineering demonstration room has been added. In the electrical department the lecture theatre has been removed to a quieter position, and is now a more commodious room. An excellent research laboratory has been provided, where the professor and his students are continuing their researches on wireless telegraphy. These include the design and insertion of instruments for measuring electrical waves used in wireless telegraphy, dielectrics, and the photometry of electric lamps. A private room, a small demonstration room, and an adequate apparatus room have been added.

In the department of applied mathematics the extensions include a general research laboratory. At the present time an elaborate research in craniology is being carried out. There are 2500 crania in store, of which 1600 are Egyptian of about 1500 B.C. and 900 Egyptian of about 7000 B.C., sent at various times by Prof. Petrie from Egypt.

The department of experimental psychology has two new rooms with adjoining dark-room accommodation allotted to it. The experimental methods now deal with all the higher intellectual processes, including attention, memory, association of ideas, judgment, apperception, the emotions, and will.

In general, we may say that the alterations enable large portions of the work of the college to be carried out in greatly more favourable circumstances than hitherto. The rooms are provided and the workers also. Much, however, is still required in the way of equipment and of endowment of research, so as to enable this to be carried out in a thoroughly efficient manner.

*UNIVERSITY AND EDUCATIONAL
INTELLIGENCE.*

MANCHESTER.—By the death of the Duke of Devonshire the University has lost its Chancellor, and although it is only a few months ago that the late Duke was elected to this office, he had as president, first of the Owens College

and latterly of the University, on many occasions taken an active part in forwarding the interests of the institution.

Under the will of the late Mrs. John Rylands, the University directly benefits by a legacy amounting to 75,000*l.*, and, in addition, the munificent endowment of the John Rylands library will be of great service to many engaged in literary study and research.

Two further recent bequests must be recorded. Mr. George Harrison, of Manchester, a retired cotton spinner, has left 10,000*l.* for the foundation of scholarships or fellowships, and Mrs. Margaret Stern, of East Barnet, 500*l.*

Prof. Ernest Rutherford, F.R.S., has been awarded the Bressa prize by the Academy of Science of Turin in recognition of the importance of his researches during the past three years.

Prof. W. Boyd Dawkins, F.R.S., has announced his intention of resigning the chair of geology, which he has held since 1874, at the end of the present session; he will, however, accept an honorary professorship and give special courses of lectures. Prof. Dawkins will continue to take an active part in the affairs of the Manchester Museum, in which he has taken so great an interest since he first came to Manchester in 1869 as its curator.

LORD RAYLEIGH will probably be elected to the vacant Chancellorship of the University of Cambridge in succession to the late Duke of Devonshire.

THERE will be an annual exhibition of students' work at the Borough Polytechnic Institute, Borough Road, S.E., on Saturday, April 4.

It is announced that Prof. A. Crum Brown, F.R.S., professor of chemistry in the University of Edinburgh, contemplates retiring at an early date from the chair which he has occupied since 1869.

PROF. P. J. WHITE having been granted leave of absence for six months on account of ill-health, the Senate of the University College of North Wales has appointed Dr. W. A. Cunningham acting head of the department of zoology for the summer term.

THE Department of Agriculture and Technical Instruction for Ireland issued recently in pamphlet form the lectures delivered during 1906 in connection with the department's scheme of short summer courses for teachers, and an account of technical instruction in Ballymena by Mr. P. F. Gillies, which appeared first in the department's Journal.

In connection with the forthcoming Franco-British Exhibition, a "children's week" is to be held. A number of French school children and their teachers, half of whom will represent secondary schools and half elementary schools, will be present. The scheme is receiving the support and sympathy of the French and British Governments, and careful preparations are being made to secure the comfort and health of the visitors. A daily educational course is to be given in the British section of education, in which both French and English children will participate. Physical exercises and games typical of both countries will take a prominent part. *Tableaux vivants*, in which the children of both nations will join, illustrating historical events and symbolical of the advantages of peace and the *entente cordiale*, will be another important item of the week's proceedings. The idea is excellent, and we are sure that no pains will be spared to make it a complete success.

In introducing in the House of Commons on Tuesday a Bill to make further provision with respect to university education in Ireland, the Chief Secretary for Ireland adopted Sir Norman Lockyer's plea for a two-power standard in education as well as in naval defence. He pointed out that the provision of adequate facilities for higher education is as necessary as the aim to be at least as strong at sea as any two foreign nations. A visit to Strassburg would be sufficient to show what the people of Germany are doing for the people of Alsace, and would also show that foreign universities may do this country, during every hour of every day of the academic year, a considerable amount of injury by way of competition. Something has been done in England, Scotland,

and Wales to supply this undoubted want. A number of teaching universities have of recent years sprung up among our great and murky towns—Manchester, Liverpool, Leeds, Sheffield, and Birmingham are now being associated in the minds of their younger citizens, not merely with docks and warehouses, not merely with shops and factories, least of all with gaols, lunatic asylums, and workhouses, but nobler structures from which are streaming forth the inspiring traditions, the ever-strengthening traditions, of university life and training. The Bill introduced proposes to establish two new universities in Ireland; these two universities to have their seats respectively in Dublin and in Belfast. In Belfast there will be but one college, the present Queen's College, and it will not be able to have any other, except, of course, by a subsequent Act of Parliament. Dublin will have three constituent colleges, and three only—Cork, Galway, and the new college, with a charter and an incorporated body in Dublin. The existing Royal University will be dissolved as from some appointed day, and its buildings, property, and endowments will be dealt with in a manner mentioned in the Bill. It is suggested, as a matter of finance, that the 20,000*l.* from the Irish Church Fund shall be divided into two equal parts, and that the university in Belfast shall take 10,000*l.* for maintenance and the new university in Dublin the other 10,000*l.* for maintenance. In addition to the present charge on the Irish Church Fund of 20,000*l.* there is a present charge upon the Exchequer of 36,500*l.*, which the Bill proposes to increase to 80,000*l.* This is the provision by way of new endowment, 43,500*l.* Belfast will thus get 10,000*l.* for its university, part of the Irish Church Fund; it will also have 18,000*l.* by way of annual endowment, making in all 28,000*l.* a year. The new college in Dublin has first of all to be built, and then endowed and maintained, and the proposal is that out of the moneys suggested 32,000*l.* a year shall endow and maintain the new university in Dublin when it has once been started. Then the income of the Queen's College, Cork, will be increased to 18,000*l.* a year, and the income of Queen's College, Galway, will be increased to 12,000*l.* a year. It is proposed also that a grant of 60,000*l.* should be made to the new University of Belfast to enable it to provide itself with a university worthy of the province to which it belongs. It is believed that a *maximum* sum for the purpose of the University and college in Dublin should be 150,000*l.*, which, it is hoped, will be sufficient first of all to complete the present university buildings.

SOCIETIES AND ACADEMIES.

LONDON.

Zoological Society, March 17.—Dr. Henry Woodward, F.R.S., vice-president, in the chair.—Some observations on the effects of pressure upon the direction of hair in mammals: Dr. W. Kidd. This paper was a sequel to other communications on the subject of the direction of hair, and consisted chiefly of the observed effects of the pressure of harness on certain regions of the coats of domestic horses. This pressure was shown to produce reversed areas of hair, and it was held that these results supported the view put forward in other papers that changes in the arrangement of hair are due to mechanical causes. Fifty-three cases were brought together, and eight different regions of the coats of the horse were shown in which the effects of pressure were found.—Mammals obtained by Mr. C. H. B. Grant in the Gorongosa Mountains, Portuguese S.E. Africa: O. Thomas and R. C. Wroughton. This was the ninth of the series of papers on the mammals of the Rudd Exploration of South Africa. One hundred and fifty specimens were dealt with, belonging to thirty-one species and subspecies, of which three were described as new.—Notes upon some species and geographical races of serows (*Capricornis*) and gorals (*Nemorhedus*), based upon specimens exhibited in the society's gardens: R. I. Pocock. It was pointed out that the "grey" goral of the Himalayas was originally described by Hardwicke as *Antelope goral*, and that the "brown" goral, to which the specific title *goral* has been applied in recent literature, required a new name. The author proposed to call it *Nemorhedus hodgsoni*. Concerning the genus *Capri-*

cornis, he stated that although only one form had been hitherto distinguished from the Himalayas, the available material pointed to the existence of at least four subspecies in that mountain range.

Geological Society, March 18.—Prof. W. J. Sollas, F.R.S., president, in the chair.—The Carboniferous rocks at Loughshinny (county Dublin), with an account of the faunal succession and correlation: Dr. C. A. Matley and Dr. A. Vaughan. After an introduction recalling the succession at Rush, already described by the authors, a detailed account is furnished of the various sections in the Loughshinny area. About 1100 feet of Carboniferous rocks are exposed. They consist mainly of limestone, but also include a thick mass of conglomerate and many intercalated beds of shale and chert. The rocks have been much folded, and to some extent faulted. The lowest rocks belong to some part of the Dibunophyllum zone, the higher range through Cyathaxonia beds into Posidonomya Limestones and shales of Pendleside age. The Lane Conglomerate may be on or near the horizon of the Rush Conglomerate. Local decalcification has caused the more or less complete disappearance of some of the Cyathaxonia and Posidonomya Limestones. The region was close to an old shore-line of the Carboniferous Limestone Sea, the actual position of which appears to have been almost parallel to, and a short distance seaward of, the present coast-line between Rush and Skerries.—A note on the petrology and physiography of Western Liberia (West Coast of Africa): J. Parkinson. The country is low-lying, with a gradual rise northward from shore-level, and rivers mature in character with alluvial flats raised above flood-level. Where the River Tuma falls into the River St. Paul the remnant of a hanging valley can be seen. Flat-topped ridges and isolated hills trending parallel to the foliation of the gneiss are characteristic of the country around Sanoyei and Boporo. There is a striking absence of late deposits of old gravels and sands. In the southern part of the district there are indications of a series of garnetiferous gneisses, tremolite schists, kyanite schists or gneisses, garnet-graphite gneisses, &c., associated, with others of granitic type, the latter being apparently free from microcline and containing a pleochroic pyroxene. These rocks are replaced in the north by biotite gneisses and hornblende schists, which have an approximate and singularly constant east-and-west (magnetic) strike in their foliation. Microcline is common. These old crystalline rocks are cut by an extensive series of basalts and ophitic dolerites, resembling so closely the post-Cretaceous dykes of Southern Nigeria that it is difficult to avoid the conclusion that they are of the same age.

Linnean Society, March 19.—Mr. H. W. Monckton, treasurer and vice-president, in the chair.—*Exhibits* (by permission of the director, Royal Botanic Gardens, Kew).—W. B. Hemsley: A second specimen of *Platanthera chlorantha* with three spurs. The plant exhibited a spike, each flower of which had the three petals spurred, a case of true peloria, whereas the specimen shown on January 17, 1907, had the three sepals spurred, a case of false peloria.—T. A. Sprague: Female flowers and fruits of *Sterculia Alexandri*, Harv., an extremely rare tree from Utenhage, the only locality known for it.—C. H. Wright: Specimens of (a) *Sphaerothylox algiformis*, Bisch., a rare South African podostemaceous plant; (b) *Archangiopsis Henryi*, Christ and Gilshen., a Chinese genus of Maritaceae, of which a better supply of material had been recently obtained.—*Papers*.—The Podostomata (=Pycnogonida) of the temperate Atlantic and Arctic Oceans: Canon A. M. Norman. The classification of Sars had been adopted, and the paper itself contained a complete enumeration of the group within the regions specified.—Amphipoda Gammaridea from the Indian Ocean, British East Africa, and the Red Sea: A. O. Walker. The total number of species from the three collections was fifty, in thirty-six genera, seven being new to science, and one being the type of a new genus.—A revision of the genus *Codonopsis*: T. F. Chipp. The author included the genus *Glosocoma* of D. Don, and other species which could not well be assigned to either. The genus was divided into four sections, dependent upon the attachment and insertion of the corolla and calyx.

Finally, the distribution of this genus along the mountain ranges of Asia was described and illustrated by a map on the screen.—The Holothurians of the Sudanese Red Sea: E. Hindle.

PARIS.

Academy of Sciences, March 25.—M. H. Becquerel in the chair.—The theory of flow over a vertical thin edge and without lateral contraction: J. Boussinesq. The results of the theoretical investigation of the author are compared with the empirical formula of Bazin, the latter representing numerous experiments. The agreement is moderately satisfactory.—The theory of electrocapillarity: M. Gouy.—The determination, at the Observatory of Paris, of the systematic errors in the reproductions of the *réseaux* of the chart of the heavens: Jules Baillaud.—The applicability and various modes of representation of surfaces with coinciding lines of curvature: L. Raffy.—The application of an alternative method to the biharmonic problem: S. Zaremba.—Remark concerning a note on the differential equations of an electrified corpuscle in a magnetic field: Carl Störmer.—The gases arising from electric sparks: M. de Broglie. It has been shown by de Wattville and Hensalech that if the air supply of a Bunsen burner passes over two metallic terminals between which electric sparks are passed, the flame of the burner gives the spectrum of the metal of the electrodes. The author has examined air thus treated, and finds it to contain ions of feeble mobility (about 10μ per second in a field of 1 volt per cm.), neutral centres capable of being transformed into ions of feeble mobility by exposure to radium or Röntgen rays, and fine particles visible in a strong beam of light. The last are in part electrified, and probably constitute the chief source of the spectrum obtained.—The absorption spectra of crystals of the rare earths in a magnetic field at the temperatures of the liquefaction and solidification of hydrogen: Jean Becquerel and H. Kamerlingh Onnes. Previous work at temperatures down to -190° C. has shown that the size of the bands varies proportionally to the square root of the temperature. At -259° C. the majority of the bands no longer follow this simple law. Two of the bands from xenotime appear to pass through a minimum, and are wider at -259° C. than at -253° C. A few of the bands, however, appear to follow the same law as down to -190° C. Down to the temperature of liquid air, all the bands show an increase of intensity corresponding to an increase of absorption. This does not hold for lower temperatures, and for each band there is a temperature at which the absorption passes through a maximum.—The detection of minute quantities of helium in minerals: F. Bortas. The exhaustion is carried out by means of charcoal cooled to the temperature of liquid air, and a Plücker tube is interposed between the vessel in which the mineral is heated and the charcoal vessels. The helium being much less readily absorbed by the cooled charcoal, very minute quantities can be detected. Helium has been recognised in this apparatus in 0.02 gram of Japanese naegete.—The photography of the vibrations of the voice: M. Marage. The vibrations fall on a thin membrane of india-rubber, and are transmitted from this to a small plane mirror. Two reproductions of the photographs obtained accompany the paper. The apparatus, once set, can unroll, expose, develop, and fix 25 metres of paper without any manipulation. Various suggestions are made for practical applications.—Some examples of lines presenting a Zeeman phenomenon abnormal in the sense of the magnetic lines of force: A. Dufour. The second spectrum of hydrogen is formed of three types of line, the first being unacted on in the field, the second giving the ordinary Zeeman effect, and the third the abnormal Zeeman effect.—The action of chlorine upon dithymol: H. Cousin. The products of the action are a dichlorothymol, a dichlorothymoquinone, and a dichloride of the latter compound.—Some derivatives of phenylisoxazone: A. Wahi and André Meyer. Condensation is readily effected between phenylisoxazone and aromatic aldehydes, the product being precipitated in nearly quantitative yield.—The products of the action of aluminium chloride and hydrochloric acid gas on benzene: G. Gustavson. Methyl-

phenylcyclopentane has been isolated from the numerous products of this reaction.—Some derivatives of thiophene: V. **Thomas**. Magnesium acts on α -iodothiophene in presence of ether, giving an organomagnesium compound which behaves similarly to phenyl magnesium iodide in many of its reactions. Details of the products resulting from the action of various ketones are given.—The formation of acetic aldehyde in alcoholic fermentations: A. **Trillat**. The experiments described prove that acetic aldehyde is not a true product of fermentation, since if the fermentation is carried out in the presence of hydrogen or carbon dioxide, air being carefully excluded, no aldehyde can be detected. If air is freely admitted during the fermentation, more aldehyde is produced than if a little air is present.—The production of gum in the Moringa: F. **Jadin** and Volcy **Boucher**.—The phytology of the eastern region of Kabylie and Djurdjura: G. **Lapie**.—The levers in the organism: A. **Guillemain**. A discussion of the efficiency of the leg muscles and bones considered as levers.—The discovery of Paleolithic paintings of man and animals in the Portal cave: René **Jeannel**. More than forty paintings of animals and human beings have been found on the walls of this cave. None of the designs have been cut into the rock, and they are coloured either black or red, both in line and flat wash. Some of the objects are partially masked by stalagmitic deposit. Two designs represent man on foot in profile; others represent bison, reindeer, and horses, the last being the most numerous. Photographs have been taken of some of the objects, and the remainder will be photographed shortly.—Anemometric studies of helices copied from animals: Paul **Amans**.—The Pliocene and Pleistocene eruptions of Limagne: Ph. **Glaugaud**.—Contribution to the study of the solar calorific radiation: C. **Féry** and G. **Milochau**.

DIARY OF SOCIETIES.

THURSDAY, APRIL 2.

ROYAL SOCIETY, at 4.30.—Complete Survey of the Cell Lamination of the Cerebral Cortex of the Lemur: Dr. F. W. Mott, F.R.S., and Miss A. M. Kelley.—The Alcoholic Ferment of Yeast Juice. Part III. The Function of Phosphates in the Fermentation of Glucose by Yeast Juice: A. Harden and W. J. Young.—The Antagonistic Action of Calcium upon the Inhibitory Effect of Magnesium: S. J. Melzer and J. Auer.—Studies on Enzyme Action. XI. The Hydrolysis of Raffinose. XII. Emulsin: Prof. H. E. Armstrong, F.R.S., and others.

ROYAL INSTITUTION, at 3.—The Animals of Africa: R. Lydekker, F.R.S.

ROYAL SOCIETY OF ARTS, at 8.—The Navigation of the Air: Prof. H. S. Hele Shaw, F.R.S.

LINNEAN SOCIETY, at 8.—Altitude and Distribution of Plants in Southern Mexico: Dr. Hans Gadow, F.R.S.—The Anatomy of the Sapotaceous Seedlings: Miss Winifred Smith.—Notes on some Spenges recently collected in Scotland: Dr. N. Anandale.

CIVIL AND MECHANICAL ENGINEERS' SOCIETY, at 8.—Efficiency of Boiler Heating Surface: C. Humphrey Winfield.

CHEMICAL SOCIETY, at 8.35.—The Condensation of Epichlorohydrin with Phenols: D. R. Boyd and E. R. Marle.—Rate of Hydrolysis of Chloroacetates and Bromoacetates, and of α -Chlorohydrin by Water and Alkali, and the Influence of Neutral Salts on the Reaction Velocities. Preliminary Note: G. Senter.—A New General Method of Preparing Diazonium Bromides: F. D. Chattaway.—On the Probable Nature of the Impurity found in the Triphenylmethane Spectrum: W. N. Hartley.—The Absorption Spectrum of Triphenylmethane: A. G. G. Leonard.—The Constituents of *Cyperus Origanum* Oil. Isolation of a New Terpene (Cigreneh): S. S. Pickles.

INSTITUTION OF ELECTRICAL ENGINEERS, at 8.—High Speed Electrical Machinery: G. Stoney and A. H. Law.

FRIDAY, APRIL 3.

ROYAL INSTITUTION, at 9.—The Modern Motor Car: Lord Montagu of Beaulieu.

INSTITUTION OF CIVIL ENGINEERS, at 8.—Notes on the Foundations of an Indian Bridge: G. W. N. Rose.

SATURDAY, APRIL 4.

ROYAL INSTITUTION, at 3.—Electric Discharges through Gases: Prof. J. J. Thomson, F.R.S.

MONDAY, APRIL 6.

VICTORIA INSTITUTE, at 4.30.—History of the Spread of the North American Fauna: Prof. J. L. G. Reay.

AMSTERSINGHIAN SOCIETY, at 8.—Impressions and Ideas: H. Wildon Carr.

CITY OF CHEMICAL INDUSTRY, at 8.—Considerations affecting the "Strength" of Wheat Flours: J. L. Baker and H. F. E. Hulston.—Note on Murexide as a *quendam* Dye Stuff and Printing Colour: W. Smith.

TUESDAY, APRIL 7.

ROYAL INSTITUTION, at 8.—The Egyptian Sudan: its History, Monuments, and Peoples, Past and Present: Dr. E. A. Wallis Budge.

PHYSIOLOGICAL SOCIETY, at 8.30.—A Monograph of the Chiropteran Genus *Uroderma*, Inchi-shens, and Allies: Dr. Knud Andersen.—On

Certain Points in the Structure of the Cervical Vertebrae of the Okapi and the Giraffe: Sir Ray Lankester, K.C.B., F.R.S.—Some Australian Spiders: H. R. Hogg.

INSTITUTION OF CIVIL ENGINEERS, at 8.—The King Edward VII. Bridge, Newcastle-on-Tyne: F. W. Davis and C. R. S. Kirkpatrick.

JUNIOR INSTITUTION OF ENGINEERS, at 8.—Purification of Water: George H. Hughes.

WEDNESDAY, APRIL 8.

ROYAL SOCIETY OF ARTS, at 8.—Technical Education in America: Sir W. H. Preece, K.C.B., F.R.S.

THURSDAY, APRIL 9.

ROYAL INSTITUTION, at 3.—The Animals of South America: R. Lydekker, F.R.S.

FRIDAY, APRIL 10.

ROYAL INSTITUTION, at 9.—The Carriers of Positive Electricity: Prof. J. J. Thomson, F.R.S.

ROYAL ASTROLOGICAL SOCIETY, at 8.—An Experimental Investigation of the Nature of γ Rays: Prof. W. H. Bragg, F.R.S., and Mr. Madsen.—Experiments on Artificial Fulgurites: Miss D. D. Butcher.—Short-spark Phenomena: W. Duffell, F.R.S.

INSTITUTION OF MECHANICAL ENGINEERS, at 8.

SATURDAY, APRIL 11.

ROYAL INSTITUTION, at 3.—Electric Discharges through Gases: Prof. J. J. Thomson, F.R.S.

CONTENTS.

	PAGE
Electricity and Matter. By E. R.	505
Charting the World's Commerce	506
Masonry and Concrete Arches. By T. H. B.	507
Our Book Shelf:—	
Strecker: "Das Kausalitätsprinzip der Biologie."—	
J. A. T.	507
Koch and Gilg: "Pharmakognostisches Praktikum"	508
Simroth: "Die Penultimations-theorie."—R. L.	508
Sedgwick: "The Minimising of Maurice, being the	
Adventures of a very small Boy among very small	
Things"	508
Stroobant: "Les Progrès de la Photographie astronomique."—W. E. R.	508
Revere: "Ilaterizil"; Ragno: "La Tecnologia delle	
Saldature autogene dei Metalli"	508
Letters to the Editor:—	
Mendelian Characters among Shorthorns.—Prof.	
James Wilson	509
The Nature of γ and X-Rays.—Charlton D. Cooksey	
Martinmas in May.—Rev. C. S. Taylor	510
An Annotated Copy of Newton's "Principia."—	
Bruce Smith	510
Two County Bird-books. (Illustrated.)	511
Modern Nitre Beds. By A. D. H.	513
Prominence and Coronal Structure. (Illustrated.)	
By Dr. William J. S. Lockyer	514
Dr. A. W. Howitt, C.M.G. By Dr. A. C. Haddon,	
F.R.S.	515
Notes. (Illustrated.)	516
Our Astronomical Column:—	
Astronomical Occurrences in April	520
Comet 1907 II.	520
The President of the Astrographic Congress	520
The Helium, D ₃ Line in the Solar Spectrum	520
Two Remarkable Spectroscopic Binaries	520
Variation in the Radial Velocity of β Ursæ Majoris	520
Dr. Nordmann's Variable Star Observations	520
The National Physical Laboratory during 1907.	
(Illustrated.)	521
The North Sea Fisheries Investigations. (Illustrated.)	
By Frank Balfour Browne	523
Extensions at University College, London	525
University and Educational Intelligence	525
Societies and Academies.	526
Diary of Societies	528

THURSDAY, APRIL 9, 1908.

EXPERIMENTAL EMBRYOLOGY.

Experimental Zoologie. Part I. Embryogenese. Eine Zusammenfassung der durch Versuche ermittelten Gesetzmässigkeiten tierischer Ei-Entwicklung (Befruchtung, Furchung, Organbildung). By Dr. Hans Przibram. Pp. 125; 16 plates. (Leipzig und Wien: Franz Deuticke, 1907.) Price 7 marks.

SOME three years ago Dr. Przibram, who is well known as a brilliant representative of the school of experimental zoologists, published "An Introduction to Experimental Morphology," which met with wide acceptance. The present volume is an expansion of part of the "Introduction," and forms an independent treatise on experimental embryology. It is to be followed by four other parts, dealing with regeneration, evolution, vitality, and function, and the whole will form a text-book of experimental zoology. If the subsequent parts are like the one before us in lucidity and thoroughness, Dr. Przibram will earn the gratitude of all interested in this dynamic aspect of the science; and who, nowadays, can afford to stand aloof? The present volume discusses, in the light of experimental results, the processes of fertilisation, cleavage, gastrulation, and differentiation, and sums up in an analysis of the influence of chemical stimuli, moisture, density of the medium, pressure, gravity, electricity and magnetism, light and heat. There is a copious and carefully executed bibliography, and the figures in the plates, which are partly compiled and partly original, are very clear and interesting.

The author discusses large and difficult problems, in regard to which there is room for considerable difference of opinion, but his treatment of these is thoroughly objective and undogmatic. We cannot do better than give some samples of his general conclusions. Fertilisation, whether artificial or spermatoc, brings about a withdrawal of water from the egg; this accelerates the vital processes which are going on of themselves, and the egg passes from a relatively resting state to progressive development. The unfertilised egg has an organisation of different kinds of substances which guarantees the forthcoming manifoldness. The direction of the first cleavage is in a plane at right angles to the axis of the first karyokinetic spindle, and the position of the latter is determined by the geometrical architecture of the egg and the fertilisation-meridian (on which the spermatozoon enters).

In regard to the familiar sequence of centrosome division, astrosphere formation, nuclear division, cytoplasmic division, and perhaps also the progressive differentiation of the blastomeres, we must not suppose that any particular link in the chain is the necessary cause of the next link; we must rather suppose that a common cause evokes them in succession, and that their cooperation secures the typical development. Provisionally we may say that the common cause of the mitotic phenomena lies in a localised change in

the fluidity of the enchylemma and the associated arrangement of a monocentric into a dicentric surface-tension-system. The second and subsequent cleavages depend on a rhythmic recurrence of the metabolic relations involved in the first cleavage (the entrance of oxygen conditioning the continuance of the metabolism, the intensity of which changes with the changes in the proportion of absorbent surface to assimilatory volume), and on the presence of antagonistic substances, which partly prevent the complete separation of the blastomeres (calcium), and partly secure a certain cohesion (sodium).

The arrangement of the blastomeres depends on Plateau's law of the smallest surface, modified by differences in the consistence of different parts of the ovum, which are also responsible for the different sizes of the blastomeres (Balfour's law). Blastulation and gastrulation depend on chemotactic influences, which are set at work by metabolic processes, and admit not only of passive-mechanical displacements, but of active migrations as well. In different zones of the egg there are chemically different substances which normally condition the differentiation of the various organs. Thus the blastomeres acquire a prospective value. If there is no rearrangement of material, an artificial fractioning of the egg is followed by a self-differentiation of the fragments, so that semi-embryos, quarto-embryos, and so on, result; but if a re-arrangement is effected, restoring the *status quo* of the intact ovum, then dwarf complete embryos result. The prospective potency of such blastomeres is greater than their prospective value. The influence of external factors is subsidiary when compared with the internal formative factors, and animal embryogenesis may be described as an almost quite perfect self-differentiation in Roux's sense.

We have stated these general conclusions because of their great interest, but it must be noted that the bulk of the book is a terse statement of concrete facts from which the expert student may draw his own conclusions, and at this stage that is well.

J. A. T.

GEOLOGICAL REVIVALISM.

Geologische Prinzipienfragen. By E. Reyer. Pp. x+202. (Leipzig: W. Engelmann, 1907.) Price 4.40 marks.

THIS work recalls, with renewed interest, a remarkable paper by Mr. Reyer on the Schlossberg of Teplitz, to which the attention of the present writer was directed by Prof. Judd nearly thirty years ago. Are not some of Reyer's models still preserved in London, and have not these models, and respectful visits to the Schlossberg itself, influenced many of us in our attempts at teaching ever since? Mr. Reyer, however, when he went further into the theory of the formation of mountains by the protrusion of masses from below and the gliding of the superincumbent layers, found the geological world opposed to him, and he turned, as he now informs us (p. v.), to fields of sociological activity. Yet he should surely be satisfied with the numerous references to his

A A

work, especially on volcanic questions, in Zittel's "History of Geology" or Geikie's monumental "Text-book." Ampferer's recent exposition of "Unterströmung," moreover, as a cause of mountain-crumpling comes very near in many of its details, though not in its foundations, to Reyer's theory of superficial "Strömung." (see NATURE, vol. lxxvi., 1907, p. 423). Though Ampferer quotes very few authorities, it seems likely that Reyer's views are still fruitifying, even if they bear forbidden fruit. At any rate, we may welcome his return to the arena at a time when no champion can assert that his own views on mountain-building have satisfied all known conditions.

Mr. Reyer himself, in this clearly-written treatise, proposes to leave his statements and arguments unburdened by a bibliography. The numerous illustrative diagrams suggest in most cases drawings made from models, and some of them represent the results of experiments performed in plastic materials. There is a freshness of exposition that brings home to us many facts that are familiar, but which are often liable to be passed over without adequate consideration. The exposition itself is, if we may say so, diagrammatic. The author points out very early how delta-deposits slide upon the rocks beneath them, and how a loose valley-side moves out towards the river, which carries away the material, and thus renders the land-flow less apparent. From p. 52 onward we read of massive extrusions of material from the molten interior of the earth, and we remember the sliding of the deltas when we are asked to picture successive extrusions as lifting the crust above them and allowing of a lateral slip of the ruptured sedimentary layers. The great difference between these postulated extrusions and our common notions of intrusive bodies appears to lie in their long-continued and successive character, whereby a later igneous mass causes a previous one to bulge up and swell out as a coat, through which the later mass may break. It is urged that if this occurs below a deep ocean, the extruded matter may become as crystalline as granite, and subsequent sediments may be laid down on it with a false appearance of having been invaded.

All this should probably be kept in mind, but we doubt if the average field-observer has been so often misled as Mr. Reyer would wish us to believe. He opposes the idea of the differentiation of a common igneous magma (p. 61), since acid and basic magmas must have separated early in the history of a cooling globe, and massive protrusions are likely to mix them up again, so as to produce the phenomena observed. Such protrusions or extrusions are held to be sufficient to explain the existence of infolds of sediments between adjacent igneous masses (pp. 69 and 155); and an admitted revival of the "crater of elevation" theory appears on p. 73. There is much in the book that is in pleasant accord with the views consistently maintained in Britain in regard to the relations of various types of igneous rock; and the principle of successive extrusions (or may we say intrusions?) has been adopted, to mention only two examples, by Prof. Sollas for

the Leinster Chain and by Dr. Harker for the gabbros of the Cuillin Hills.

Mr. Reyer's views cannot fail to make us think more carefully, and we trust that his book will be widely read by those who have to interpret the history of great regions of the crust. We may hereafter be grateful to him for maintaining the theory of gravitational gliding (pp. 142, 147, &c.) as opposed to the crumpling of strata by lateral thrust against the influence of gravitation. In this respect he has re-lighted a very ancient candle, which burnt brightly in Scrope's hands in 1825 ("Considerations on Volcanos," pp. 201-2). It will now, in all probability, never be entirely put out. GRENVILLE A. J. COLE.

HYDRAULICS.

Hydraulics. By F. C. Lea. Pp. xii+536. (London: Edward Arnold, 1908.) Price 18s. net.

WHATEVER may be the extent to which the science of hydraulics was neglected during the century which elapsed between the theoretical researches of Bernoulli and the practical applications of Armstrong, it cannot be urged that there is any lack of attention to the subject at the present time, if one be permitted to judge from the number of text-books which have appeared within recent years, and even within the last few months. So striking an output must surely be fraught with great potentialities.

The science of hydraulics has a field which is somewhat vague and ill-defined, and is of greater or less extent according to the views of different writers. Originally, the definition of the term only covered a reference to the laws which governed the motion of fluids in pipes and water-courses. Then it was extended to include the use of water for motive purposes, and the means and appliances by which that end was achieved. Other developments have followed, and now it is rare to find two text-books covering even approximately the same ground, or agreeing in respect of either limits or order of treatment. We are acquainted with one treatise which includes within its purview the principles of lubrication; with another which regards what is commonly differentiated as the science of pneumatics as a constituent section; with a third which ignores the motion of bodies in fluids; and so on.

The range of the treatise under consideration, though not so extreme as in some cases, is nevertheless exceedingly comprehensive, and it may be added that the treatment is very complete. In view of the license to which allusion has just been made, we do not presume to offer any criticism on the propriety of presenting the elementary principles of hydrostatics as an introduction to the subject; we ourselves should hardly have thought of referring to a text-book on hydraulics for them. No doubt it is useful for the student to have his memory refreshed on fundamentals, though he may not unreasonably be supposed to have acquired a competent knowledge of them elsewhere. Still, there they are for consultation, if required, and they form a not inapt introduction.

The laws governing floating bodies are touched upon, and investigation is carried so far as to cover the eminently practical and up-to-date case of the floating dock. From these considerations, the author proceeds to deal with the subject of fluids in motion, which constitutes the essential feature of the book. He makes Bernouilli's theorem his starting-point, following on to Torricelli's law and the theory of flow through mouthpieces with the coefficients due to various forms of orifice. Then, having dealt with weirs, he directs his attention to fluid flow through pipes and channels, explaining the well-known basic formula,

$$v = c \sqrt{mi},$$

and quoting the values assigned to the coefficient by Chezy, Bazin, Darcy, Ganguillet and Kutter, and others. This brings us to chapter vii., in which we find a description of the methods adopted for gauging the flow of water through an orifice, in streams and in pipes, including a brief reference to Stromeyer's suggestion for the use of a chemical agent. Chapter viii. treats of the impact of water on vanes, and thence it is a natural transition to water-wheels and turbines in chapter ix. Both this chapter and the following, on pumps, are very full and explicit, and are effectively illustrated by a number of typical examples. Chapter xi. is devoted to an exemplification of the application of hydraulic power to industrial purposes by means of various machines. In two short concluding chapters the author deals with the modern investigation of stream-line flow and the resistance to motion of bodies in water.

An admirable feature of the work is the large number of worked numerical examples. The type is clear and the illustrations are good. Altogether the work forms an excellent text-book, and is cordially to be recommended to students of this most interesting and useful science.

TECHNICAL CHEMICAL ANALYSIS.

Traité complet d'Analyse chimique appliquée aux Essais industriels. By J. Post and B. Neumann. Second French edition, by Dr. L. Gautier. Vol. i., part i. (pp. 217, price 6.50 francs). Vol. ii., part i. (pp. 202, price 6 francs). (Paris: Librairie scientifique, A. Hermann, 1907-8.)

THE present review is concerned with the first two instalments of the second French edition of a German treatise on technical chemical analysis, which has already passed through three editions in the original. The complete work will consist of two volumes divided into eight sections, each section dealing with some special branch of analytical practice, and the editors have secured the cooperation of some twenty-seven eminent contributors in order that the various chapters may embody the results of the latest experience. Judging by the style of the first two sections, now before us, it would appear that the editors are aiming rather at a clear and succinct outline of contemporary analytical method, and of the general

nature of the materials to which they are applied, than at an elaborate and detailed treatise. Subject to this proviso, they may be congratulated on having so far achieved a considerable measure of success, and their efforts may be commended to British chemists who feel the need of a manual of this description.

Vol. i., part i., deals with such subjects as water, solid fuels, pyrometry, and gas analysis in a fairly complete and satisfactory manner. The opening chapter on water analysis (pp. 1-38), by Dr. H. Vogel, of Berlin, is somewhat too compressed and desultory to be of real use, and might be advantageously enlarged in future editions. Then follows an excellent *résumé* by Dr. H. Langbein of the methods in vogue for the chemical analysis and calorific valuation of solid fuels (pp. 39-73); the value of this chapter would have been enhanced by a fuller treatment of the ash analysis of coals and its importance in relation to the various uses of the raw fuel. The third chapter, by Prof. B. Neumann, of Darmstadt, on pyrometry (pp. 74-126), deals very completely with the various thermo-electrical and optical methods used in technical practice, and so far as these methods are concerned the treatment of the subject is all that could be desired. The scanty references to the air thermometer and to electrical resistance methods are, however, to be regretted.

The concluding chapter, on gas analysis (pp. 127-217), also by Prof. Neumann, is disappointing in that it deals with little else than the crude and untrustworthy methods of Hempel and Orsat (or various modifications of them), which have long been the despair of workers, who instinctively demand something both accurate and convenient, and which, we had hoped, were being rapidly discarded in technical laboratories. In these days, when the applications of gaseous fuels are increasing daily, the introduction of really accurate methods of gas analysis in technical practice is fast becoming an urgent necessity, and it is quite a mistaken notion that methods of precision are necessarily inconvenient or tedious, and therefore unsuited to the exigencies of a works laboratory. The opinion of Dreschmidt, quoted on p. 136, as to the incompleteness of the absorption of carbonic oxide by an ammoniacal solution of cuprous chloride may be disputed, since it can easily be demonstrated that a properly prepared and *fresh* solution will absorb the gas almost as rapidly, and, for all practical purposes, as completely, as a caustic alkali absorbs carbon dioxide. It may also be remarked that there is no reference to gas calorimetry in this chapter.

Vol. ii., part i., dealing with the physical, mechanical, and chemical testing of limestones, mortars, cements, ceramic products, glass, and the like, has been entrusted to Drs. H. Seger and E. Cramer, of Berlin. Their treatment of the subject is admirably clear and succinct, and will certainly be appreciated by all general readers. Whilst there is nothing very new, good judgment has been exercised in selecting the best methods and appliances, and the whole is a singularly well-balanced production, and eminently readable. The one fault to be found with their work is the paucity of the references to analytical literature.

The two sections are clearly printed and admirably illustrated, but, as is unfortunately the case with the majority of chemical treatises published on the Continent, references to British work and authorities are conspicuous by their absence.

W. A. B.

BRITISH ARCHÆOLOGISTS IN ITALY.

Papers of the British School at Rome. Vol. iv. Pp. x+296; illustrated. (London: Macmillan and Co., Ltd., 1907.) Price 31s. 6d. net.

THE "Papers of the British School at Rome," while similar in format, are not similar in form to the "Annals of the British School at Rome," nor can they be precisely similar in content, since the pleasure of chronicling the results of actual excavations is denied to the director of the British School at Rome. Let us always gratefully recognise the greater liberality of the Hellenic authorities and the greater tolerance of the Greek archaeologists, who, while naturally and rightly desirous of keeping Greek antiquities in Greece, at the same time recognise the fact that the antiquities of classic Greece and Rome are the heritage of the whole civilised world, not of one country alone, and admit that the privilege of searching for them should be freely extended to all who have the money and the will to carry out the work. Some day, perhaps, the Italians will do likewise. Until then, British archaeologists in Italy are confined to the contemplative life, and can do little more than write papers of the type presented in the volume under review.

The director, Mr. Thomas Ashby, most approaches the standard of the practical work of the Athens school in his very interesting paper on the "Classical Topography of the Roman Campagna," which is illustrated by good photographs, perhaps somewhat unnecessarily reproduced abroad, either in France or Italy, as the lettering beneath them shows. Probably we hardly realise how intensely hideous was the Roman style of country-house architecture, until we see such a place as Sette Bassi, which Mr. Ashby illustrates. It must have looked exactly like a warehouse, or, more probably, a piano factory. All the beauty and grace of "classical" architecture is Greek; the Romans were by nature as inclined to unredeemed utilitarian ugliness in their architecture as are the Germans or ourselves. Of the other papers, Mr. A. J. B. Wace's "Studies in Roman Historical Reliefs" is an interesting piece of critical work. Mr. Yeames, late of the British Museum, assistant director of the school, has some interesting remarks on Roman art of the post-Antonine period (first half of the third century A.D.) as exemplified in a small ivory statuette of a *gobbo* or hunchback in the British Museum.

The last paper, and in some ways the most important, is on "The Early Iron Age in South Italy," by Mr. T. E. Peet, who reaches interesting conclusions. In his preface the director says that the papers

"of Mr. Yeames and Mr. Peet, the latter especially.

NO. 2005, VOL. 77]

though still belonging to the archæological sphere, deal with departments of it which have not previously found a place in the Papers of the School."

Since to the minds of many the department of archæology represented by Mr. Peet's paper seems the most important of all, it is to be hoped that no future Papers of the School at Rome will fail to contain some contribution on the prehistoric antiquities of Italy, about which we want to know far more than we do at present.

H. H.

OUR BOOK SHELF.

Armature Construction. By H. M. Hobart and A. G. Ellis. Pp. ix+348. (London: Whittaker and Co., 1907.) Price 15s. net.

THE widespread use of dynamo electric machinery for all sorts of purposes is sufficient justification, if such be required, of treatises dealing with the design and construction of such machinery. Many books have been written on this subject, but we believe this is the first time that a complete volume has been devoted to the consideration of the construction of what is, perhaps, the most important part of any dynamo, viz. the armature.

To those who know anything of this class of machinery, it will be obvious that there is ample scope for a writer with first-hand knowledge to compile an interesting and valuable book; to mention only one point, the practical construction of a good commutator is a process full of interest. The book before us will certainly repay careful study in spite of a certain lack of proportion which is very noticeable.

A very brief summary of the contents is as follows: The first seven chapters describe the various workshop processes whereby the mechanical parts of the armature are built up, that is to say, the armature stampings, the spider, and the commutator; the next two chapters are devoted to armature windings for direct-current machines and for alternators, treated diagrammatically; and the last four chapters to the methods of winding and to finishing and testing. When it is stated that 172 pages (including full-page illustrations) out of a total of about 390 are devoted to winding diagrams alone, it will be apparent that the authors have allowed their enthusiasm for such diagrams to get the better of their judgment. There is no doubt that the subject is of great interest, but in the opinion of the present writer the two lengthy chapters devoted to it are quite out of place in such a work; in so far as explanations are necessary for the proper understanding of subsequent chapters, three or four pages would be ample to furnish all that are required.

The chapters that deal with construction pure and simple are well written and illustrated, and contain a large quantity of valuable information. Chapter ii., on armature laminations, is perhaps the best in the book, and contains specifications for the composition of suitable steel; the various methods of testing the quality of the steel are described, and constants are given which may be taken as satisfactory. The process of stamping the core plates is given in detail, and is illustrated with a number of photographs of slotting presses and other tools. The other chapters are also full of interest, and, but for the error of judgment mentioned above, the whole book might be unreservedly recommended to those who from one cause or another are concerned with the practical details of armature construction.

The Dancing Mouse; a Study in Animal Behaviour.

By Robert M. Yerkes. Pp. xxi+290. (New York: The Macmillan Company; London: Macmillan and Co., Ltd., 1907.) Price 5s. net.

THE most characteristic feature of the best psychology of the present day is the tendency to look for much of the explanation of mental life in its antecedents and surroundings. The older individualistic position is being rapidly left behind. The continuity of mind is now as clearly recognised as the continuity of life. Lower forms of mental activity, in the race no less than in the individual, are found to throw much light upon the nature of developed human consciousness. Such forms are, however, matters of inference, not of direct observation; it is therefore not surprising that the science of comparative psychology is so far from keeping pace with its elder brother, comparative anatomy. The work thus far done has been of a somewhat sporadic nature, in one prominent case, at least, vitiated by faulty psychological theory. More decided progress may be looked for in the application of the experimental method.

Dr. Yerkes's book on the Japanese dancing mouse, the first of a series to be devoted to the study of animal behaviour, is an excellent example of this plan of procedure. A very full description is given of the two principal forms of test employed, viz., the light-discrimination test and the labyrinth test. The former was employed to investigate not only the visual discrimination of the animal, but also its powers of learning by experience and of retaining the lessons thus learnt. As "motive" to the use of the discriminative faculty, Dr. Yerkes employed punishment, in the form of mild electric shocks for mistakes made, considering this not only more humane than the motive of hunger usually employed in such experiments, but also better adapted to the peculiarities of behaviour of the animal, viz., its superabundant activity. Here the criticism at once suggests itself that such a mode of procedure would probably encourage a mechanical production of habit in the animal, and fail to stimulate any germs of higher mental faculty that might be present. The results obtained certainly fail to show the presence of any reasoning power above sense discrimination. Even the inference to power of discrimination may not be completely justified. Sense-differentiation and the mechanical working of hedonic selection would seem able to account for all the facts. Yet the mice might have been capable of higher mental processes, e.g. in terms of kinesthetic imagery, which the experiments failed to call into operation owing to the insufficiency of the stimulus or motive employed.

Apart from its value as a contribution to science, the book is an extremely readable one, and is, moreover, admirably bound and printed. W. B.

Studies in the Medicine of Ancient India. Part i., Osteology, or the Bones of the Human Body. By Dr. A. F. Rudolf Hoernle, C.I.E. Pp. xii+252. (Oxford: Clarendon Press, 1907.) Price 10s. 6d.

SOME time ago, when Dr. Hoernle was preparing an edition of two old Indian medical tracts, preserved in the Bower manuscript of the fifth century A.D., he was surprised to find how little we knew of medicine as taught and practised in Ancient India. The volume under review is the first fruit of a resolve to make good that deficiency in the history of medicine so far as it can now be made good by a study of existing manuscripts and documents. Of the three systems of medicine which have come down to us the most ancient is that ascribed to Atreya, a physician who is assigned by Dr. Hoernle to the sixth century B.C.; the system ascribed to Susruta, the

surgeon, is nearly as ancient; the third system, that of Vagbhata, the Galen of the mediæval East, as Dr. Hoernle describes him, dates from the seventh century A.D., and is a compound of the two older systems.

Evidently amongst the ancient Indians, as among medical men of to-day, a knowledge of the bones was regarded as fundamental in the study of medicine. In the system of Atreya the number of bones in the human body is given as 360 (the nails, teeth, and tooth sockets are counted as separate bones); in that of Susruta 300, while in Vagbhata's system they number 360. In modern text-books of anatomy the number of bones is variously estimated from 200 to 214, the number varying according to the inclusion or exclusion of certain small bones and some which are only occasionally present. The ancient Indian anatomist shows an intimate knowledge of animal tissues in classifying the cartilages with bones; he regarded cartilage as an immature form of bone. In the course of transcription the text naturally became corrupt; for instance, in Atreya's system the two humeri, four wrist bones and two eyes (their outer coat was believed to be cartilaginous, hence they were classified as bones) came to be omitted, but the total number of 360 was made good by increasing the number of face and neck bones. In all three systems the thumb is stated to have three joints or phalanges; Dr. Hoernle points out that a similar mistake is made in the summary of bones given in the Talmud. The Talmudic summary, probably derived from the Greek school at Alexandria, follows very closely the systems of Ancient India. How far the systems of medicine amongst the early Greeks and the Ancient Indians were related cannot yet be estimated; thanks to the labours of Dr. Hoernle we know much more of the systems practised amongst the Indians than amongst the Greeks.

Altogether Dr. Hoernle, although not a medical man himself, has laid medical men under a deep obligation to him by rendering so easily accessible the knowledge and practice of physicians who tended the sick in northern India some centuries before Christ was born.

The Sea-shore, Shown to the Children. By Janet Harvey Kelman. Described by Rev. Theodore Wood. Pp. xi+146; with 48 coloured plates. (London and Edinburgh: T. C. and E. C. Jack, n.d.) Price 2s. 6d. net.

THIS book belongs to the "Shown to the Children" series, and consists of forty-eight coloured plates with a short description written in the simplest possible language of each of the subjects depicted.

From such an immense choice of material it was no doubt difficult to decide what should be described and what left out, but, on the whole, we think that the choice has been a very good one. The chief objection to the book is the use of English names for most of the objects described. Some of these names are unfamiliar to us, while others are surely local. In some cases the generic name has been used, e.g. Chiton, Purpura, Pinna, Terebella, &c., and we think it would have been an advantage if this system had been more freely adopted, the English names only being used where there could be no doubt whatever as to their being well-known ones. Alecyonium is called "the sea-finger"; in some localities, at least, it is known as "dead men's fingers." Pleurobrachia is called "the sea-acorn," but in another well-known book of the sea-shore its English name is given as "the sea-gooseberry." The name "sea-acorn" is usually applied to a barnacle.

This attempt to give English names to objects not

well known has led to an unfortunate use of the terms caterpillar and chrysalis, which are here applied to the zoea and megalopa stages of the crab.

We can understand the desire on the part of the author to bring home to the children the fact that the zoea and caterpillar represent the larval stage in the life-histories of crab and butterfly, and that the chrysalis of the butterfly and the megalopa of the crab are also corresponding stages, but to call a zoea a caterpillar and a megalopa a chrysalis is carrying comparison too far.

FRANK BALFOUR BROWNE.

Déviations des Compas. By Pierre Engel. Pp. vi+64; with 3 plates. (Paris: Gauthier-Villars, 1907.) Price 2.75 francs.

THE brief introduction well describes the subject-matter of the book. It is divided into four parts. The first consists of a theoretical study of the magnetic field of a ship. It is quite simple, and involves no knowledge of mathematics beyond the rudiments of trigonometry. The second part is equally elementary in its treatment, and deals with the action of the field in question on a magnetic needle, together with an outline of the principle of compensation. The third part deals with the compensation of the Thomson or Kelvin compass, while the fourth part consists of various information and remarks, both general and particular, relating to the Thomson compass. Of the plates, the third and fourth are charts of the world showing curves of equal horizontal intensity and equal magnetic inclination respectively. Ensign Engel has produced a book which should be of great use to naval officers, to whom a knowledge of the principles of the modern mariner's compass is indispensable, but to whom a highly mathematical treatment would be prohibitive.

Bulletin of Miscellaneous Information. Royal Botanic Gardens, Kew. Pp. 421+152. (London: Darling and Son, 1907.) Price 5s.

THIS volume of the *Kew Bulletin* is the second of the regenerated series. For the most part the contents are connected with systematic or economic botany. Herbarium workers have contributed lists of new flowering plants from Africa and elsewhere, reductions of the Wallichian herbarium, identifications of algæ and fungi, and special articles. The rubber boom is featured in several articles, notably in the accounts of Guayule rubber, obtained from *Parthenium argentatum*, and of Mgoa rubber, the product of the East African tree *Mascarenhasia elastica*. Various additions have been made to the wild fauna and flora of the gardens, the most important being the list of lepidoptera compiled by Mr. A. L. Simmons. Notes on the cricket-bat willow and on gardens and parks in South Wales represent the work of members of the gardens' staff, and articles have been contributed from India and Africa by former members of the staff.

The Will to Doubt: an Essay in Philosophy for the General Thinker. By Alfred H. Lloyd. Pp. xi+285. (London: Swan Sonnenschein and Co., Ltd., 1907.) Price 4s. 6d.

THE thesis defended in this, the latest, volume of Prof. Muirhead's ethical library is that doubt is no mere negative of belief, but a positive element absolutely necessary to real life. It is true that the common-sense view of the world is full of contradictions that furnish abundant food for doubt, and that no less must be said of the more special and abstract views which constitute the sciences. But though Prof. Lloyd thus agrees with Mr. F. H. Bradley in holding that our experience at all its levels is "riddled

with contradictions," he does not follow the Oxford philosopher to his famous conclusion that all experience is therefore only of "appearance" and not of "reality." In his view, on the contrary, contradiction actually serves experience by holding it down to the real world which it would otherwise miss. It follows that the "doubter's world" must always present certain positive features which will accord with the principles of Descartes, the typical modern doubter. Among these will be found psychophysical parallelism and "the immortality of whatever is indeed real."

Prof. Lloyd's argument is interesting, and is ably, if not always convincingly, developed, but suffers from his somewhat perverse and strained efforts after brilliance of style. He has, moreover, shown more courage than prudence in choosing a title which inevitably suggests comparison of his work with that of his compatriot, Prof. William James.

LETTERS TO THE EDITOR.

[The Editor does not hold himself responsible for opinions expressed by his correspondents. Neither can he undertake to return, or to correspond with the writers of, rejected manuscripts intended for this or any other part of NATURE. No notice is taken of anonymous communications.]

An Annotated Copy of Newton's "Principia."

IT may interest your correspondent (p. 510) to know that Le Neve, in his "Pedigrees of Knights" (Harleian Soc., 1873, viii., p. 192), states that Sir Demetrius James, of Itham, was knighted on May 10, 1665. An account of the family may be found in Hasted's "History of Kent," vol. ii., p. 247.

Much information about the preparation of the second edition of the "Principia" may be found in Brewster's "Memoirs of Sir Isaac Newton," vol. ii., p. 273 et seq., but it is needless to burden your columns with quotations from so accessible a book. Two specially bearing on the point at issue will suffice:—"Even in November 1702, when he [Newton] was visited by Bd. Greves, who saw in his hands an interleaved and corrected copy of the Principia, he would not acknowledge that he had any intention to reprint it." "In a letter dated October 11 [1700], Newton intimated to Cotes that he had sent him by Mr. Whiston 'the greatest part of the copy of his Principia, in order to a new edition,' thanked him for his letter of the 18th of August, and requested him not to be at the trouble of examining all the Demonstrations, but 'to print by the copy sent him, correcting only such faults as occur in reading over the sheets,' which would entail upon him 'more labour than it was fit to give him.'"

The results of Mr. Smith's further inquiries will be awaited with interest.

W. R. B. PRIDEAUX.
Reform Club, Pall Mall, S.W., April 2.

Proposed Alteration in the Calendar.

WITH reference to the proposed alteration of the calendar so ably discussed by "W. T. L." in NATURE of March 26, it seems to me that the drastic scheme advocated by Mr. Pearce is not only inadmissible because interfering with the continuity of the weeks, but it is not the simplest scheme that could be adopted, even allowing the interference proposed.

The Positivist Calendar agrees with Mr. Pearce's proposal in that it divides the year into fifty-two weeks with a supernumerary day which is not included in any week, and with two such supernumerary days in leap years. The two calendars are also alike in that these supernumerary days are not included in any month. But the Positivist Calendar is the simpler of the two in that it makes all the months of the same length, namely, four weeks; and Blackstone informs us that in law a month means "28 days, unless otherwise expressed."

This makes the number of months in the year thirteen; but it has this advantage over Mr. Pearce's scheme, that not only are the months all of the same length, but that they all begin on the same day of the week, and thus any given day of the month is on the same day of the week in every month.

The seven-day week, which is no doubt descended from the Jewish week, is one of the most widely spread institutions in the world. All Christian and all Mohammedan nations, although they may agree in little else, agree in respecting the week; and it would be impossible to induce many of them to interrupt the continuity of their weeks by excluding one day annually from any week and two days every fourth year, and unless the change were international and all but universal it would only introduce confusion and destroy that identity of the week which now obtains throughout Christendom and Mohammedom.

D. MACKIE.

4 Polmuir Road, Aberdeen, March 28.

Helium in the Atmosphere.

RECENT investigations have demonstrated the widespread presence of the inert gases in the crystalline rocks, and the Hon. R. J. Strutt has shown that while the bulk of the gases in granite consists of nitrogen, there is a small but appreciable quantity of argon and helium, the former amounting to from three to four times the latter. On the disintegration of the rocks a portion of these must find their way into the atmosphere. The question arises whether our present atmosphere contains the accumulations of past accessions from the earth's crust, in the same way as the sodium chloride in the sea represents, subject to certain qualifications, the sum of the contributions of the rivers in the past.

It is found, however, that while the air examined in our laboratories contains about 1 per cent. of argon, there are only one or two parts in a million of helium. The small proportion of the latter has given rise to the suggestion that it is escaping from the atmosphere as fast as it enters it. This receives no support from the kinetic theory of gases. Dr. G. H. Bryan calculates (Phil. Trans., A, xcvi., p. 19) that at a temperature of 127°C. it would take eighty-four thousand million years to remove a layer 1 centimetre thick of helium from the surface of the earth. In other words, the pressure of the gas which at the beginning of that period was found at the height of a centimetre would at its end, other conditions remaining the same, be found at the surface of the earth.

Dr. Johnstone Stoney, however, supposes that there may be extraordinary molecular velocities, due to collisions and other causes, which result in the loss of helium. Such an hypothesis, however, is quite unnecessary, for, according to the ordinary views as to the constitution of gases, they will not distribute themselves uniformly in the atmosphere, but to a certain extent take up positions according to their relative densities. Mr. J. H. Jeans ("Dynamical Theory of Gases," 1904, p. 316) calculates that if helium forms a millionth part by volume of the air at sea-level, it must amount to more than 2 per cent. at an altitude, which is dependent on temperature. With our increasing knowledge of atmospheric temperature and the distribution of helium in the earth's crust, we ought soon to be in a position to calculate the present amount of free helium, and employ it to obtain an approximate higher limit for the total disintegration of crystalline rocks since the consolidation of the earth's crust.

J. W. EVANS.

April Meteors.

MOONLIGHT will prove a serious impediment to observations of the Lyrids in the present year, the more especially as, according to calculations made by the writer, the general maximum of these meteors will take place immediately after full moon. The following are particulars as to when meteor showers at this period may be expected to make their appearance, and the computed intensity of the display in each instance, the results being expressed in Greenwich Mean Time:—

Epoch, April 18. Shower of second order of magnitude;

the maxima precede the epoch, the principal of which occur on April 16, 6h. 25m.; April 16, 14h.; and April 17, 6h. 50m.

Epoch, April 18, 15h. This shower is of the twenty-second order of magnitude, and has its principal maxima on April 16, 7h. 45m.; April 16, 9h. 40m.; and April 17, 13h. This minor shower has also two secondary maxima, occurring on April 17, 23h., and April 18, 3h., respectively.

Epoch, April 21. This shower is of the twenty-first order of magnitude, its principal maxima, which precede the epoch, occurring on April 19, 16h. 35m.; April 19, 19h. 20m.; and April 20, 17h.

Towards the end of April there is another meteor shower of the ninth order of magnitude, the epoch of which occurs on April 29, 6h., and the principal maxima of which fall on April 27, 16h.; April 27, 19h. 30m.; and April 27, 21h.

As a general rule, the intensity of a meteoric display is inversely as its estimated order of magnitude; hence meteors may be expected to be most abundant on the night of April 16, as the two strongest maxima of a shower of the second order of magnitude occur on this date, besides two maxima of another shower which is partly superimposed on the former. Lyrids will probably be most in evidence on the morning of April 17.

Dublin.

JOHN R. HENRY.

Coloration of Glass and Quartz by Radium.

ON many occasions attention has been directed to the coloration of glass and quartz by the rays from radium. The coloration of glass is generally connected with the presence of manganese or lead, and I venture to suggest that in quartz too the darkening arises from the association of some foreign substance with the silica.

A small plate of quartz crystal was exposed to radium for three weeks, and became, not only irregularly violet at one place, but also showed two sharply defined parallel lines strongly coloured, with the space between them scarcely affected. On the other hand, a quantity of powdered chemically pure silica acquired no colour after the same exposure. It may also be pointed out that pure boric acid, fused to a transparent plate and protected from moisture, was unaffected by radium even after two months' continuous exposure to the rays.

Borax, however, will show a slight action after three weeks, and both these substances afford, when incorporated with a small quantity of pure sodium silicate, a good basis for the production of experimental glasses to test the action of radium when other constituents, such as lead, iron, &c., are added either singly or together.

It may be found that the coloration by radium will serve as a test for the purity of the silica used in making vessels for certain classes of chemical research, so that, apart from its physical interest, the matter seems worth following up.

CHARLES E. S. PHILLIPS.

Castle House, Shooters Hill, Kent, April 2.

An Early Notice of Neolithic Implements.

THE subjoined quotation must, I think, be among the earliest specific descriptions of a Neolithic implement found in this country.

Newbery's "A Compendious History of the World" (vol. 1., London, 1768, pp. 11-12):—"That the earth has been amazingly altered since its first formation is evident from the spoils of the sea being daily discovered even in the midst of rocks and the tops of mountains: to which let me add that the skeletons, horns, &c., of the animals of one country, have been dug out of the bogs and mines of another, even at an immense distance, and where such animals are not now to be found: even stones have been discovered at a great distance in the earth, which bore evident marks of art about them; and some time since I had two taken out of a peat pit near Newbury in Berks, which were large, ground to an edge in the form of an ax, and so perfect that wood might be cut with them."

JOHN L. MYRES.

The University of Liverpool, March 23.

NOTES ON ANCIENT BRITISH
MONUMENTS.¹

VIII.—THE ABERDEEN CIRCLES (Continued).

IN my last notes I dealt, amongst other matters, with those circles devoted, as I believe, to the observation of clock-stars. It is from these that dates can be derived when we are sure of the star. I pointed out that we were not sure of the star, which might have been either Arcturus or Capella.

I must confess that although, as I have already said, there is no definite proof that the period of B.C. 600 is to be preferred to B.C. 1600 as the mean time of the setting out of the Aberdeen circles, such considerations as I then gave point to the more recent date. I may add that the N. circles, if used to determine the time at night, tell the same tale. With little knowledge of the heavens we can understand the importance of an exact alignment to Arcturus or Capella when, in my view, the astronomer-priest took his departure and told the curate left in charge to "keep her at that"; but when the stars were more familiar there would be less need to indicate the rising places of either Arcturus or Capella, and the four circles with due N. alignment indicate probably that there was no longer

need for a rising star to be considered; the position of the brighter stars in relation to the Pole star in the circumpolar region itself could be used, and there can be little doubt that it then became a question of the nightly voyage of the Great Bear round Polaris. In such observations we have the beginning of the employment of the "night dial" used throughout Britain until a century ago, and of the system of observation by which the Arabs in the Soudan still tell the time at night to within ten minutes.

The question of the number of stones in the circles may also help us. The once existing condition of things at Crichtie, fully illustrated in Anderson's admirable book on Scotland in pagan times ("Stone Age," p. 105), is worthy of consideration. The circle consisted of six stones only; the meridian is clearly marked, and my observations made from the outstanding stone show that it was quite accurately laid off. This fact and the other that the cist was found in the middle of a north alignment are, in my mind, proofs of relative modernity. One question, then, is, May we accept all small circles, such as Crichtie and Tuack, as being more modern than those in Cornwall and even in Aberdeenshire, where the number of stones in the circle is greater? The many interments in these circles also favour this view.

And now a word about the May-year circles; from these astronomically we can get no date, but we know that in the south they preceded the solstitial circles, and perhaps it is permissible to make the same assumption for Aberdeenshire, but in this case we deal with recumbent stones, so again they are dissimilar, and therefore their date is probably not the same as those in the south.

¹ Continued from p. 489

So far as my work has gone, we have alignments to the May year at Berry Brae and Hutton of Ardoyne; the remains of a May-year avenue at Ardlair and another marked on the Ordnance map near Kirkton of Clatt. The true azimuths of the May sunrise near Aberdeen are approximately:—

Sea horizon	...	N. 57° 50' E.
Hills 1"	...	60
" 2"	...	61° 30'

In my reductions I have taken the magnetic variation at W. 18° 45' provisionally until the recent results obtained by the Admiralty and Ordnance Survey are known.

It is remarkable that either the recumbent stones or supporters, or both, have been disturbed in these May-year circles, suggesting a practice acted on by the Egyptian priests in regard to the worship of any other sun- or star-god than the one to which they were specially attached.

This is an argument in favour of the erection of the May-year circles before the solstitial ones at Midmar, Sunhoney and Stonehead, which have been left intact.

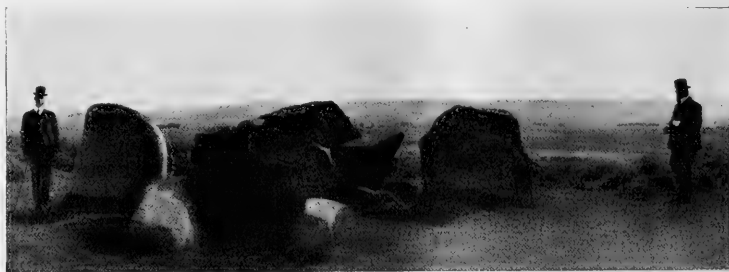

FIG. 22.—Contrasting the directing stone and supporters at Ardlair.

The most remarkable case of disturbance is at Ardlair, on the N.W. of the circle area.

This is one of the exceptional cases to which I referred in (2), where the only May-year avenue I have measured occurs, hence the circle may once have been a May-year one. With the single exception of Old Bourtree Bush, where the recumbent stone is due E. of the centre of the circle to define the place of the equinoctial sunsets, all the circles I have measured have the recumbent stone in the S.W. quadrant. This general condition has been previously noted by Mr. Coles, and also by Mr. Ritchie, who informs me that in the case of the only variation from this law he has noted, it is known that the recumbent stone, having been moved by the farmer, was *wrongly replaced* when he was compelled to restore it.

At Ardlair the recumbent stone is in the S.E. quadrant, but there are indications that this was not its original position. It is unlike any other recumbent stone I have seen; I believe its many sharp angles and cracks are due to the action of fire, and the angles and cracks are all the more striking since both supporters are rounded and crackless.

The removal of the stone from its position facing the May sunrise, subjecting it to the action of fire, and placing it between two stones in the circle, so that its length would lie in the direction of that sunrise, are all suggested as acts of the solstitial priests.

The mean of all my measures gives an azimuth

along the stone and its supporters of N. 61° 15' E.; the azimuth of the May sunrise with hills 2° high is N 61° 30' E.

The other exceptional case is at Garrol, where there has been great disturbance, and where, as at Ardlair, the length of the recumbent stone lies in the direction which points to the rise of the May sun, the mean of many measures giving N. 61° 45' E.

My measurements of the May-year circles were as follows:—

May-year. Sun's Declination 16° 20' N. (May 6, August 8).

Circle at—	Azimuths.		Elevation of the horizon.	Declination N.	Dates.	
	Magnetic mean of observations.	True, at right-angles across circle.			May.	August.
Berry Brae	170	N. 61 15 E.	1	15 30	May 3	Aug. 11
Hutton of Ardoyne	166	N. 57 15 E.	1	17 18	May 9	Aug. 8
Mean of above...	1	16 19	May 6	Aug. 8

Some of the previous measures in Cornwall may be given for comparison:—

Monument at—	Azimuth (true).	Elevation of horizon.	Declination N.	Dates.	
				May.	August.
Boscawen-un—
Circle to two large menhirs	N. 66 50 E.	1 0	14 55	May 1	Aug. 13
Merry Maidens—
Circle to Fougou	N. 64 0 E.	0 30	16 21	May 6	Aug. 8
Tregesal—
Circle to Longstone	N. 67 20 E.	1 18	15 3	May 2	Aug. 13
Longstone (Tregesal)
To W. Lanyon Quoit ...	N. 67 0 E.	0 0	14 3	Apr. 23	Aug. 16
Down Tor—
Direction of avenue.....	N. 67 0 E.	0 30 (assumed)	14 23	Apr. 30	Aug. 15
St. Cleer—
Holy well to Treveithy cromlech	N. 64 0 E.	0 30 (assumed)	16 21	May 6	Aug. 8
Lesquoit cromlech—
Orientation of Cromlech.	N. 64 0 E.	1 30	16 55	May 8	Aug. 6
Draids Altar (Pawton)—
Orientation of cromlech.	N. 64 0 E.	1 30	16 55	May 8	Aug. 6
Mean of above	15 38	May 4	Aug. 10

In addition to these, I have found¹ that Lukis² and Borlase³ give plans of a number of cromlechs in Cornwall which appear to be oriented to the May sun. They are as follows:—

Cromlech.	Authority.	Azimuth.
Lanyon Quoit	Borlase; plate XXI	N. 66 E.
Mulfra Quoit	Lukis; plate XIX	N. 63 E.
Chywoone Quoit	Lukis; plate XX	N. 64 E.
Zennor Quoit	Lukis; plate XXI	N. 64 E.
Three Brothers Grugith	Lukis; plate XXIII	N. 64 E.
Mean of above...	...	N. 64° 12' E.

Assuming an elevation of the horizon between 1° and 2°, this mean value is the exact azimuth of the May sunrise in Cornwall.

I next give details touching the solstitial circles.

¹ See NATURE, No. 1987, vol. lxxvii., p. 84, November 28, 1907.
² The Prehistoric Stone Monuments of Britain—Cornwall.
³ "Antiquities of Cornwall."

With these, accurate measurement is a difficult matter, and, as the determination of the date of erection from the variation of the obliquity of the ecliptic entails very precise measures, I content myself with pointing out that the declinations are probably solstitial and that they agree, in the mean, with the values previously obtained for the English solstitial circles.

Circle at—	Azimuths.		Elevation of the horizon.	Declination N.
	Magnetic mean of observations.	True, at right-angles across circle.		
Sunhoney	0 1'	N. 52 35 E.	0	23 25
Midmar	153 15	46 30	2	23 15
Stonehead (Insch).....	146 15	37 30	1	23 45
Mean of above...	23 47

I append some measures made in the south of England for comparison:—

Monument at—	Azimuth (true).	Elevation of the horizon.	Declination N.
Stonehenge—
Direction of avenue from circle...	N. 49 34 E.	0 35	23 54
Stanton Drew—
Great circle to N.E. circle.....	51 0	2 5	23 49
Boscawen-un—
Centre of circle to fine menhir ...	53 30	1 15	23 58
Tregesal—
Centre of circle to holed stones...	53 20	1 15	23 2
Longstone (Tregesal)—
To Mén-an-Tol	50 30	0 34	24 7
Mean of above,	23 34

General Conclusions.

Should subsequent inquiries confirm the balance of argument against the use of Capella, we shall be led to the following conclusions:—

(a) Dealing with the circles already measured by me in the two localities, the Aberdeen circles are more than a thousand years younger than those of Cornwall and the west coast; and here we have one reason why the east-coast circles are dissimilar, and those at Callernish and Stennes to the west are similar, to the Cornish circles.

(b) With this great difference of time to deal with, we have also probably a difference of origin between the West coast and East coast swarms.

(c) As the May year is still supreme in Scotland generally, it is clear that the solstitial Aberdonians were at some point of time overpowered in influence by a return wave from the west of Scotland.

Since my return from Aberdeen Mr. Horton Bolitho, one of the hon. secretaries of the Cornwall branch of the Society for the Astronomical Study of Ancient Monuments, and whose knowledge of the Cornish alignments is second to none, has sent me the following information concerning the circles in Perthshire:—

"I examined six circles in Perthshire last year and this, but I found no trace of recumbent stones such as are associated with the Aberdeen circles. The Perthshire circles closely resemble the circles of Cornwall, showing traces of May-year and solstitial alignments with at least one clear use of a clock-star in azimuth N. 18° E. Trees prevented any fine measurements being taken, and local assistance in searching for outstanding stones was lacking. In two of the best pre-

¹ At Sunhoney, as the recumbent stone was curved and irregular, it was simpler to measure directly across the circle at right-angles to the length of the recumbent stone; the magnetic azimuth thus obtained was 71° 20'.

served circles I found a central or 'Gorsedd' stone, and in one case two central stones."

Mr. Bolitho's observations then intensify the purely local fashion of the Aberdeen circles.

One of the associated inquiries to which I have referred will be to trace the existence of recumbent stones in some part of Europe; another will be to see if the area of the recumbent stone has also special ethnological or craniological characteristics.

With regard to the first point, Anderson ("Stone Age," p. 124) tells us that in Norway and Sweden there is no example of a circle with a recumbent stone and supporters.

With regard to the second, the paper on British ethnology by Mr. J. Gray (*Man*, April, 1902) is full of promise.

A point worthy of notice is the great preponderance in the number of circles used to take the time at night over those enabling the seasonal changes and the sun's place throughout the year to be fixed. In Cornwall both were equally provided for.

We may, I think, include the circles with a north alignment with the clock-star circles as used to determine the time at night. They are respectively situated at Dyce, Whitehill Wood, Raes of Clune and Candle Hill (Insch). As before stated, they probably represent a later development when the observer's knowledge was so far advanced that he needed only the cardinal point in order to recognise the clock-stars which it was necessary for him to observe.

Judging by the trouble taken to determine time at night by the use of special circles in Aberdeen, religious services at fixed hours of the night are suggested to be as early as the time of the circle builders.

As these night observations were common to the two localities, we may conclude that in both, the circle associated with the *via sacra*, the chambered cairn, the holy well and the holy thorn, and the sacred festivals, represent the earlier form of the monastery buildings of later times.

I am anxious to conclude by expressing our deep obligations to many helpers. First of all to Dr. Fraser for his invitation to come and do some more work, his generous hospitality, and the use of his motor-car for the examination of the circles within a radius of twenty miles of the Granite City, some of which we saw under his own guidance. That is the first point; next comes the local help in four distinct regions—Inverurie, Durriss, Buchan and Insch. For the Inverurie district Mr. Ritchie, of Port Elphinstone, gave up two of his precious Saturday holidays, during which he piloted us to many circles which he had most carefully selected from a much larger number as being best worth examining.

At Durriss Mr. Braid and his son took us to the circles at Eslie and the Raes of Clune, and, further, had prepared a careful plan of the latter circle, thus fulfilling a promise made last year.

On our arrival at Mintlaw for the study of the Buchan circles, we found the Rev. Dr. Forrest, Mr. Ainslie, and his assistant, Mr. Gall, at the station, and with their help several circles near Mintlaw and Lonmay were measured.

Later on we proceeded to Insch, and passed two nights in the comfortable Railway Hotel there. The obliging landlord, Mr. Haddon, had taken immense pains to secure local information. Colonel Smith, and Mr. J. Graham Callander who had only returned two days from studying Greek inscriptions in Asia Minor, accompanied us on each of the days, and with their help we were enabled to measure seven circles, some of which were many miles from our headquarters.

NORMAN LOCKYER.

TREES.

AMONG the many excellent books which have been written about trees there are none, in our opinion, better than the present work. It is full of interest from cover to cover. The many beautiful photographs of the different parts of trees are strikingly true to nature, and, having been taken from fresh material, they show the salient features of the different species much more clearly than could be observed from dried herbarium specimens. We have also beautiful portraits of the various trees themselves in summer and winter condition, as well as special plates illustrating the appearance of the bark. The accompanying illustration will speak for itself.

In his introduction Prof. Groom has given a very interesting and clear account of the various members, both vegetative and reproductive, which make up the body of the tree. The special function of each part



Bark of Cork Oak. Part of an illustration in "Trees and their Life-histories."

and the influence of the environment on its activity is described in a way which the non-botanical reader should have no difficulty in following and thus laying a clear foundation for the better understanding of trees and their life-histories. It is difficult to say which part of the book is best, but in the introduction the author has broken new ground. A great fault in many similar works is that they contain a mere accumulation of facts, and dry, formal descriptions of different trees and their various parts, which the non-botanical reader may learn and thus get to know the various species by head mark. This is all very well so far as it goes, but surely it will make

1 "Trees and their Life-histories." By Prof. P. Groom. Pp. xvi+407; illustrated from photos. by H. Irving. (London: Cassell and Co., Ltd., 1907.) Price 25s. net.

the study of trees much more intelligible and interesting when the meaning of structure and form is clearly and simply described to the student, as in the present work.

After this excellently written and beautifully illustrated introduction, the author takes up the gymnosperms. He does not attempt to deal with every known species, but certainly there are few which are likely to be met with in various pinetums, parks, and forests in this country which have not been dealt with. The life-history of each is clearly and well described and illustrated by photographs. As Prof. Groom states in his preface, "Particular trees have been selected for more detailed discussion, so as to serve as types by which to demonstrate certain structural features or general phenomena observable in tree-life." The study of the conifers appeals to a vast number of people, and a distinct gap in the existing literature has been filled by this work. No doubt other books give descriptions of the different species, but these are too condensed and technical to be of any use to the general reader. The broad-leaved trees are similarly dealt with in an interesting and masterly manner. Analytical tables and diagnosis of families have been added. These, together with the numerous illustrations and the special mention of distinctive features which is prefixed to the account of every tree described, will certainly ensure facility and accuracy in identifying the different kinds of trees with which the reader is likely to come in contact.

The author is to be congratulated upon the production of a work which should certainly be in the possession of all those interested directly or indirectly in trees and their growth. A. W. B.

DR. JAMES BELL, C.B., F.R.S.

WE regret to have to announce the death, on March 31, in his eighty-fourth year, of Dr. James Bell, formerly principal of the Somerset House Laboratory. Dr. Bell was a native of County Armagh, and entering the Inland Revenue Service became, when a comparatively young man, an assistant in the chemical department of Somerset House, then under the charge of Mr. George Phillips. This department, the forerunner of the present Government Laboratory, was the outcome of the Tobacco Act of 1842, and was created with the object of supplementing the provisions of that Act in suppressing the adulteration of tobacco. For his chemical education Dr. Bell was mainly indebted to the late Prof. Williamson. Indeed, in the early days of the Somerset House laboratory a close association existed between it and University College, and a number of the first assistants were trained in theoretical and practical chemistry in the Gower Street Laboratories, and some of them, like Duffy, Kay and Railton, were encouraged by Dr. Williamson, then in the full vigour of his scientific activity, to try their prentice hands at original investigation. In the first years of its existence the laboratory, the staff of which consisted solely of Mr. Phillips himself, was almost exclusively engaged on the objects for which it was founded, but as its utility became more and more apparent its operations were gradually extended, and eventually embraced the examination of practically every excisable article. The laboratory at this period was also largely concerned with inquiries as to the brewing values of various materials, and on the methods of determining original gravities, and on the denaturing of spirits of wine so as to permit its use for manufacturing purposes without danger

to the revenue—all of which work found its application in subsequent Acts of Parliament.

On the death of Mr. Kay, Mr. Bell became deputy principal, and he continued in that office until the retirement of Mr. Phillips in 1874, when he succeeded to the principalship, holding that position until his resignation in 1894. During the fifty years of its existence the operations of the laboratory had greatly extended, and it had contracted associations with practically every Government department which had need of chemical advice and assistance, in addition to the large extension of its work connected with Revenue matters. Much of this development took place during Dr. Bell's principalship. But to the public at large Dr. Bell's tenure of the office was mainly signalled by the association of the Somerset House laboratory with what is in reality one of the least important of its many duties, viz. the Food and Drugs Acts. This popular misapprehension of the proper functions of the laboratory is no doubt due to occasional newspaper references to the fact that a disputed case of analysis of some food-stuff, drink or drug has been referred by magistrates to the Commissioners of Inland Revenue for the opinion of their chemical advisers. As a matter of history, this connection of the Somerset House laboratory with the Food and Drugs Acts occurred at the very time that Dr. Bell succeeded to the principalship, as a result of a report of a Select Committee of the House of Commons on the working of the Act of 1872, and this circumstance caused the laboratory to be known to the public at large to a much greater extent than formerly.

The new responsibility thus thrown on Dr. Bell involved a very considerable increase of work on the department, not so much in actual analysis of referred samples as in investigations into the methods of food analysis in general and in the establishment of standards of quality. Thirty years ago the methods of food analysis were, for the most part, in a very unsatisfactory condition. The great teachers of chemical analysis, Berzelius, Rose, Wöhler, Thomson, Bunsen, Fresenius, and the men trained in their schools, were mainly concerned in the discovery and elaboration of the methods of mineral analysis, and very little attention had been paid to processes for the systematic examination of food with a view to the determination of its quality or to the detection of adulteration. The first Food and Drugs Act was largely ineffective owing to this circumstance. When the office of a public analyst was first created, practically each analyst had to devise his own methods, and at the outset no uniformity or agreement was possible. The condition of things to which this gave rise, with the consequent frequent instances of injustice, was indeed the cause of the appointment of the Select Committee above referred to.

As regards methods of analysis, Dr. Bell, as the referee eventually appointed under the Act of 1875, was in no better position than other analysts who held office under the Act, and he at once turned all the force and ability of his laboratory to the elaboration of the methods for the examination of such articles of food and drink as experience showed most frequently came within the purview of the Act. In this work he was assisted by some of the most competent analysts the laboratory ever possessed, notably Mr. George Lewin, the late Mr. Harkness, the late Mr. John Holmes, and Mr. Cameron, each of whom did veoman service in getting together the material embodied in the work by which Dr. Bell is best known, viz. his "Chemistry of Foods." It was mainly in recognition of the service thus rendered to the community that Dr. Bell was elected into

the Royal Society in 1884, and was made, two years later, a graduate of the Royal University of Dublin. His official position further led to his selection as president of the Institute of Chemistry in 1888. He was one of the original members of the Institute, and took much interest in its operations. He was made a Companion of the Bath in 1889.

Dr. Bell enjoyed the respect and esteem of many successive Boards of Inland Revenue, who found in him a shrewd and astute adviser of ripened judgment and large experience, eminently cautious and sound. His *bonhomie* and geniality, his strong common sense and tactful sympathy, his fairness and obvious impartiality rendered him an admirable agent in the conduct of the occasionally complicated and difficult adjustments of the apparently conflicting interests of the "Trade" and the Revenue, which the head of the laboratory is now and again called upon to determine. He was loyally served by his staff, who entertained warm feelings of regard and affection for him. Many of them testified to their appreciation of his many good qualities by their presence at his funeral on Saturday last at Ewell.

T. E. T.

NOTES.

THE sixteenth James Forrest lecture of the Institution of Civil Engineers will be delivered at the institution on Monday, April 27, by Prof. Henry Louis, who has selected for his subject "Unsolved Problems in Metal Mining."

THE Geological Society of London is taking a poll of all the fellows resident in the United Kingdom to ascertain whether a majority is in favour of admitting women to the society, and, if so, whether as fellows or as associates.

DR. W. N. SHAW, F.R.S., and Dr. T. H. Warren, Vice-Chancellor of the University of Oxford, have been elected members of the Athenæum Club under the provisions of the rule of the club which empowers the annual election by the committee of three persons "of distinguished eminence in science, literature, the arts, or for public services."

DR. HENRI DESLANDRES, who since 1897 has been assistant director of the observatory at Meudon, has been appointed director to succeed the late Dr. Janssen.

DR. J. N. LANGLEY, F.R.S., professor of physiology in the University of Cambridge, has been elected a foreign member of the Royal Danish Scientific Society.

THE third International Congress of Philosophy will be held at Heidelberg from August 31 to September 5. Prof. Windelberg is to be president, and Dr. Elsehaus Plock, of Heidelberg, is acting as secretary.

THE annual dinner of the Institution of Mining and Metallurgy will be held at the Hotel Cecil on Friday, May 8. The president, Mr. A. James, will preside, and many distinguished guests have already accepted invitations to be present.

WE learn from the *British Medical Journal* that the Town Council of West Ham has passed a resolution authorising the placing of a bronze tablet on the house in Upton Lane, Forest Gate, now St. Peter's Vicarage, where Lord Lister was born.

THE sixth International Congress of Psychology will be held at Geneva from August 31 to September 4, 1909. Prof. E. Claparède, professor of physiological psychology

in the University of Geneva, is the general secretary of the congress, and may be addressed at Champel, 11, Geneva.

A NEW Polar expedition is being equipped, under the auspices of the Russian Ministry of Marine, with the object of discovering a north-east passage between the Atlantic and Pacific Oceans, and thereby accelerating naval communication between Western and Far Eastern Russia.

A CORRESPONDENT sends us a page from "Wind und Wetter," by Prof. E. Lommel (Munich: R. Oldenbourg, 1873), containing a description of the dark cloud which covered Europe and a part of Asia in 1873 (see NATURE, March 5, p. 417, and March 26, p. 493).

THE body of Emanuel Swedenborg, who died in 1772 and was buried in the Swedish Church, Prince's Square, Ratcliff Highway, was removed on Tuesday from its place of sepulture and conveyed to Dartmouth, where it was placed on board the Swedish cruiser *Fylgia* for conveyance to Sweden.

A GENERAL meeting of the American Philosophical Society will be held at Philadelphia on April 23-25. The preliminary programme, a copy of which has reached us, shows that thirty-six papers on important scientific subjects will be brought before the meeting by leading men of science in the United States.

THE Beck bequest for 1908 has been awarded by the Royal Geographical Society to Lieutenant George Mulock, R.N., on account of the survey work which he did on the National Antarctic Expedition, and the map in six sheets which he prepared after the expedition returned.

A MESSAGE from Stockholm states that it is the intention of the Swedish Government to ask the Riksdag to make a grant for a scientific expedition to Spitsbergen in the coming summer for geological and geographical research. Prof. Gerard de Geer, the Rector of the University of Stockholm, will be the leader of the expedition.

It is proposed to hold a conference of meteorologists representative of the United Kingdom and of the British colonies and dependencies in the course of the summer in Canada on the invitation of the Royal Society of Canada. The meeting was originally fixed for the last week in May. We are now informed by Mr. R. F. Stupart, director of the Canadian Meteorological Service, that it has been postponed, and is to be held in Quebec in the last week of July, immediately after the celebration of the tercentenary of Champlain's landing.

AN adult living specimen of *Lepidosiren paradoxa*—the South American lung-fish—reached the natural history department of Glasgow University some months ago, and has remained in a healthy condition. To this—the first living specimen which has ever reached the Old World—there have just been added eight others obtained by Mr. W. E. Agar on his recent expedition. It is hoped that in time it may be found possible to induce them to breed in captivity.

THE summer meeting of the American Association for the Advancement of Science will be held at Dartmouth College, Hanover, N.H., during the week beginning June 29. A committee, under the chairmanship of Prof. R. Fletcher, has been appointed to make the necessary arrangements. An invitation has been received from the president of the Blue Mountain Forest Association for members of the association to visit the Blue Mountain Forest, otherwise known as the Corbin Blue Mountain Park or Preserve, covering about 40,000 acres, where the celebrated herds of buffalo, deer, mountain goats, boars, &c., may be seen.

AGRICULTURAL science in America has lost a promising writer and teacher by the death, in his forty-second year, of Prof. Willis G. Johnson. He was formerly an instructor in the University of Illinois, and was engaged in special investigations for the natural history laboratory of that State. Later he became State entomologist of Maryland, and organised the Maryland State Horticulture Department. Of late years he had written largely on fruit-tree pests and kindred subjects, and had edited the *American Agriculturist*.

WITH reference to his article in NATURE of March 26 on the proposed alterations in the calendar, the author writes:—"In p. 489, col. 2, line 13, for 'each 132nd year' read 'each 128th year.' Dropping a leap year at the end of each latter period would be equivalent to having in that time 97 common years and 31 leap years, or 46,751 days in all, differing from 128 tropical years by only 0.00160 of a day. This is much more accurate than the Gregorian rule; and, if the latter is a little more easy to remember, that is of little advantage for what can come at most once in a lifetime."

In a letter to the Paris Academy of Sciences, Prince Roland Bonaparte announces his resolution to place the sum of 100,000 francs (3960*l.*) at the disposal of the academy for the encouragement of scientific research. This sum is not to be treated as capital, but is to be used freely in the form of annuities, not as rewards for work done, but to enable competent workers, who have already proved their capability, to carry out new researches which otherwise they would be unable to prosecute. In his letter to the academy—which appears in No. 9 of the *Comptes rendus* (March 2)—the Prince expresses the hope that his example may be followed to such an extent that a permanent fund, devoted to this end, may be established.

THE following are among the lecture arrangements at the Royal Institution after Easter:—Mr. Gerald Stoney, two lectures on the development of the modern turbine and its application; Prof. F. T. Trouton, two lectures on (1) why light is believed to be a vibration, (2) what it is which vibrates; Prof. W. Stirling, two lectures on animal heat and allied phenomena; Mr. W. Bateson, three lectures on Mendelian heredity; Dr. A. Scott, three lectures on the chemistry of photography; and Mr. G. F. Scott Elliot, two lectures on Chile and the Chilians. The Friday evening meetings will be resumed on May 1, when Prof. J. Larmor will deliver a discourse on the scientific work of Lord Kelvin. Succeeding discourses will probably be given by Dr. J. Y. Buchanan, Dr. H. T. Bulstrode, Prof. J. C. Kapteyn, of the University of Groningen, and Sir James Dewar.

A REUTER telegram states that Captain Ejnar Mikkelsen, who jointly commanded the Anglo-American Polar Expedition, returned from Alaska on April 2. Captain Mikkelsen started from Flaxman Island on October 16 and journeyed along the northern shore of Alaska, proceeding thence along the Yukon River towards Fort Gibson. The expedition traced the continental shelf in Beaufort Sea. Information was obtained concerning ocean currents which will be useful when Captain Mikkelsen makes another attempt to reach the unknown continent. Beyond the continental shelf there is water of great depth, demonstrating that Beaufort Sea is not a shallow basin, as has been supposed. The journey north was made along the 149th meridian, and soundings were taken occasionally. At a distance of sixty-four miles from the land it was impossible to touch bottom with a 320-fathom line. Mr.

Ernest de Koven Leffingwell, the expedition's geologist, has remained at Flaxman Island to carry on scientific work.

IN NATURE of February 13 (p. 345) Dr. T. J. J. See gave a quotation from Strabo suggesting that Mochus of Sidon was the originator of the theory of atoms. Dr. Dreyer pointed out, however, in the following issue (p. 368) that the so-called book of Mochus is a literary forgery. Dr. See now writes to state that, though this is the case, it does not justify the inference that Mochus himself was not a real authority of weight. In reply, Dr. Dreyer asks why should it be necessary to accept the existence of Mochus as a historical fact, simply because Posidonius was taken in by the forgery? It is known from other evidence that his mind was not very critically inclined. The book of Mochus is only one of a number of apocryphal writings about Demokritos, most of which pretend to have been written by himself, and describe his skill as a sorcerer and magician. See Zeller, "Philosophie der Griechen," i., p. 842 (5th ed.), and Susemihl, "Geschichte der griechischen Litteratur in der Alexandrinzeit," i., p. 483. Zeller points out that the roots of the philosophical doctrines of Leukippus and Demokritos are so clearly distinguishable in the earlier Greek philosophy that it is out of the question to deduce them from Eastern sources.

THE report of the Royal Scottish Museum for 1907 records a marked increase in the number of visitors, the total exceeding that for the previous year by 92,000. Although this increase may be partially accounted for by an extension of the hours during which the museum is open, it apparently indicates an increased interest in the institution on the part of the public. An unsatisfactory feature is the presence of a bonded whiskey store within less than a dozen feet from part of the west wing of the museum.

ACCORDING to the recently issued report, the Royal Zoological Society of Ireland enjoyed an unusually good season during 1907 in the matter of receipts, the gate-money showing an increase of nearly 1500*l.* over that of the preceding year. This satisfactory state of affairs is attributed in great part to the recent Dublin exhibition, aided, no doubt, by the improved attractions of the gardens themselves. On the other hand, the list of paying members shows a serious diminution. The report is illustrated by photographs of the new seal-pond and of several interesting animals. Lion-breeding continues to be carried on successfully and profitably. As the collection includes lions from both West and East Africa, as well as one from Persia, it would be interesting if the authorities would afford information as to the characteristics of these local forms.

A SHORT editorial note in the January number of the *Indian Forester* refers to the very important subject of forests and water supply, but no data from Indian territories are quoted. The extent to which camphor has been planted in eastern Asia, India, Africa, and the United States is summarised in an article on the subject, and the methods of producing camphor synthetically are indicated. A reprinted article by Mr. A. M. Smith discussing the correlation between the moon's phase and the period of felling bamboos bears out the view that the phenomena which have led to the belief are connected with the amount of water in the culms; the amount varies greatly with transpiration and with the conditions of light.

MISS E. M. FARR has compiled a catalogue of the flora of the Canadian Rocky Mountains and the Selkirk Range that is published as vol. iii., No. 1, of the Contributions

from the Botanical Laboratory of the University of Pennsylvania. Of conifers, *Pinus Murrayana* and *Picea Engelmanni* are dominant in the Rockies; *Larix Lyallii* is a conspicuous tree at high elevations, and *Tsuga Mertensiana* is another characteristic Alpine tree occurring in the west of the region. Among flowering plants, the grasses, sedges, Cruciferae, Rosaceae, and Compositae are the largest orders. In numerous interesting Alpine plants are found, as *Erythronium grandiflorum*, known as the glacier lily, *Aquilegia formosa*, *Anemone Drummondii*, various saxifrages, *Parnassia Kotzebuei*, *Lutkea pectinata*, and *Vaccinium myrtilloides*. The plants growing on Sulphur Mountain, so-called because of the hot sulphur springs, include *Primula MacCalliana*, *Saxifraga caespitosa*, *Draba nivalis*, and *Hutchinsia calycina*.

A SEMI-POPULAR account of light-emitting plants, by Dr. C. Müller, is published in the February number of *Himmel und Erde*. In 1815 Heinrich recorded the observation that light is evolved by the wood of certain trees, and later John Heller rightly ascribed the phenomenon to fungi. Hartig identified one mycelium as that of *Agaricus melleus*, and more recently Molisch showed that the mycelium of other fungi produce the same effect. The fruiting bodies of *Agaricus Gardneri*, *A. igneus*, and *A. olearius* emit light, also the Australian fungi *Panus incandescens* and *Pleurotus canescens*. The light observed in connection with dead animal matter, attributable to bacteria, is due in certain cases to the presence of *Bacterium phosphoreum*, and it is peculiar that this organism only exists at temperatures below 30° C.; other bacteria produce the luminous effect in connection with marine fishes and animals. The emission of light at sea has been variously attributed to bacteria, Peridinæ, and Pyrocistæ. A distinctly novel idea of utilising light-emitting bacteria to provide a lamp was devised by Dubois and Molisch.

WE have received from the president of the International Aeronautical Committee a summary of the places at which scientific kite and balloon ascents were made in the months September–December, 1907, in Europe, the United States, and at Helwan (Egypt). Heights of 20,000 metres and upwards were reached by registering balloons at Uccle, Brussels (25,990 metres on September 5), Strassburg, and Pyrtou Hill (Oxon). The meteorological results are not stated in the summary.

THE Deutsche Seewarte has published the results of meteorological observations for 1906 at the stations under its control, consisting of ten stations of the second order, fifty-six storm-warning stations on the coasts of Germany and hourly readings at four normal observatories. These results have been published in practically the same form for twenty-nine years, and owing to the great care bestowed upon all details connected with the service, the volume is one of the most valuable annual contributions to the meteorology of Europe.

PART III. of the year-book of the Meteorological Observatory of Agram contains the rainfall observations made in Croatia and Slavonia in the years 1905–6. In the last year there were 121 observing stations; the data form an important contribution to the climatology of those parts, the tables are worked out in great detail, and the precipitation is particularised by the usual international symbols. We note, however, that, contrary to the method obtaining in this country, the values are entered to the day of measurement instead of to the previous day.

THE usual annual summary of the climatology of the past year, based on observations made at Juvisy, appears

in the February number of the *Bulletin de la Société astronomique de France*. It is pointed out, in discussing the monthly temperatures, that only on five occasions since the commencement of the nineteenth century has the mean temperature for the month of July been lower than it was in 1907. The relation between sun-spot activity and terrestrial temperature is discussed, and it is shown that from 1879 until 1897 the annual temperature curve followed the sun-spot curve, with a maximum in 1893. The parallelism was not continued, however, during the period 1897 to 1900, but in 1901–2 there was a temperature minimum corresponding to that of sun-spots. The sun-spot maximum of 1905 was not accompanied, in these latitudes, by a thermic maximum, but it is suggested the excessive rain of that year, with its resulting lowering of temperature, was occasioned by the excessive evaporation in tropical regions.

WE have received from the Danish Meteorological Institute its report on the state of the ice in the Arctic seas for 1907. The report is in its usual form.

THE Bulletin of the American Geographical Society for January contains an article by Prof. R. De C. Ward on some problems of the tropics. Prof. Ward emphasises the bounty of nature in providing all the necessities of life in tropical latitudes, and the tendency for natives of such climates to make no attempts to attain higher civilisation. None of the energetic and enterprising nations of the world has developed under the easy conditions of life in the tropics. In considering the labour problem, the marked social gulf which is certain to ensue if white men attempt to develop tropical countries by aid of indolent natives is discussed. The white residents constitute a caste, and tend to become despotic, while the country is governed on the standards of the temperate zone. Reference is made to the tendency of Europeans to become enervated in a tropical climate, and the problem of tropical government is illustrated by the example of British India. After briefly discussing the seats of primitive civilisation, Prof. Ward directs attention to the migratory movements in history from colder to warmer climates, mentioning the descent of the barbarous tribes of the Himalayas into India, and the invasions of Greece and Rome from the north.

AN account of the earthquake of January 2, 1908, by Mr. Maxwell Hall, is published in the Jamaica weather report. The principal origin of this shock lay in the western part of the island, near Ipswich and Appleton. Rocks were thrown down in a railway cutting between these towns; many houses suffered damage in the district between Falmouth and Montego Bay; at Black River it is said that goods on shelves and in windows of shops on the south side of the High Street were thrown into the street, but those on the north side were thrown inwards. At Chapelton, Mr. Maxwell Hall reports that undulations of the ground could be seen as well as felt; this observation is interesting, as the shock was not severe, no damage was caused, and the violence, as defined by Mr. Hall, corresponds to about the fifth degree of the Mercalli scale.

IN an article in a Stuttgart newspaper, the *Deutsches Volksblatt*, Mr. Schips endeavours to apply recent chemical theories towards elucidating the origin and formation of the diamond from quartz-bearing rocks. The diamond, he points out, is always associated with silicates, and one of the minerals with radium emanation is always present. He concludes, therefore, that the diamond has been formed by the influence of the emanation on silicon.

In *Concrete and Constructional Engineering* for March Colonel J. Winn summarises recent progress in the development of reinforced concrete in Great Britain. During the past year steady advance has been made, and the decision to build the new General Post Office extensions and various small post offices of reinforced concrete will have a far-reaching effect. Another interesting article in the same issue, by Mr. W. R. Crane, deals with the use of concrete and reinforced concrete in mines. Details are given of concrete linings at several shafts in the United States. Other articles dealing with reinforced concrete in reservoir, aqueduct, and conduit construction, with a ten-storey reinforced concrete building in Pittsburg, with reinforced concrete bridges in Italy, sea defences in Holland, and leading jetty on the Manchester Ship Canal, illustrate in a striking manner the variety and number of the structures which are being executed in this material.

Two interesting papers were read before the Institution of Engineers and Shipbuilders in Scotland on March 17. Mr. H. A. Mavor discussed the electric propulsion of ships, giving a comparison of the results to be obtained on a ship of large size driven direct by steam turbines with what can be done by the application of electric gear. The ship, details of which are worked out, had a total of 17,000 horse-power delivered to the three propellers, and a speed of 20½ knots. The propellers were 8 feet 1½ inches in diameter, and the speed of revolution was 377 per minute. The maximum probable efficiency of these propellers is calculated to be 62 per cent. An electric equipment would, it is shown, permit of the use of propellers of about 14 feet diameter at 140 revolutions per minute, and an efficiency not less than 70 per cent.—an improvement more than sufficient to cover the loss in the electric motors. In the second paper Mr. W. H. Hatfield traced the evolution of malleable cast iron, and discussed its present position in the metallurgical world. He takes exception to the statement made in the report on the nomenclature of iron and steel that malleable cast iron should not be regarded as a variety of cast iron, inasmuch as it does not exhibit the extreme brittleness that characterises cast iron. He considers that it should properly be classed as cast iron. The nomenclature is, however, a matter of slight moment. The tests given by the author show that malleable cast iron can be produced giving a tensile strength of twenty-three tons per square inch with an elongation of 19 per cent., a reduction of area of 20.6 per cent., and a bending angle of 180°, results which are as good as those given by many samples of wrought iron. In structure, these castings are very similar to wrought iron.

In a note reprinted from the *Atti* of the Venetian Institution (Venice: C. Ferrari, 1908), Dr. U. Cisotti applies elliptic functions to the problem of efflux of a liquid from an opening containing an internal mouthpiece, a particular case of two-dimensional discontinuous motion. The paper forms the sequel to one in the *Rendiconti del Circolo matematico di Palermo*, xxv. (1908), on discontinuous motion in general.

The recently established Italian bi-monthly *Scienza pratica* contains a paper by Mr. Lorenzo d'Adda on the substitution of cement for steel in the armour of battle-ships. The idea was suggested to the writer by the way the Russian shells bounded off the batteries of the Japanese in the siege of Port Arthur without producing any great damage. Among the advantages suggested are a considerable saving of weight and cost; moreover, the author points out that efficient adhesion can be secured between the cement

and iron owing to the similarity of their coefficients of expansion. Other papers are an illustrated obituary notice of the late Emilio Rossetti, late professor of physics at Buenos Ayres, who was also a pioneer of engineering in the Argentine Republic, and papers on the steam turbine and the trans-Andean canal. A considerable collection of science abstracts, mainly dealing with engineering, is another important feature of the new journal.

PROF. GRUNER, of Bern, has written a small pamphlet dealing with "The World of the Infinitely Small" at the instance of the Keplerbund of Godesberg, a society which aims at the spreading of a knowledge of science amongst the people. The author has succeeded in presenting his subject in a most fascinating manner. He approaches the infinitely small by a series of steps, one of which deals with ultra-microscopic vision, and may be mentioned as illustrating the author's method. The colour of ruby glass is due, he shows, to the presence in it of minute particles of gold too small to be seen with a microscope, under which the glass looks a uniform material. When, however, the glass is examined by the ultra-microscope the gold particles appear as points of light on a dark background like stars in the sky. What, he asks, would be the appearance of these particles if we could bring to bear on them a power which exceeded that of the ultra-microscope as much as the latter does that of the ordinary microscope?

THE December (1907) number of *Terrestrial Magnetism and Atmospheric Electricity* contains an article by van Everdingen on the life and work of the late Dr. M. Snellen, director of the Royal Meteorological Institute of Holland. It deals mainly with the scientific and organising work of Dr. Snellen. Apart, however, from the character and importance of the scientific work in which Dr. Snellen was engaged, and which secured him many friends throughout the scientific world, his perfect mastery of the English tongue, his genial character, and his fund of anecdote made him a most welcome visitor to these shores, and increased the number of his admirers. We are glad to add our tribute of respect to that of the Dutch Meteorological Institute.

IN the Bulletin of the U.S. Bureau of Standards for January, Messrs. W. A. Noyes and H. C. P. Weber give an account of their re-determination of the atomic weight of chlorine. The method consists in weighing the hydrogen absorbed in palladium and the chlorine in the form of potassium chloroplatinate. The hydrogen, on being passed over the heated chloroplatinate, combines with the chlorine to form hydrochloric acid, which is condensed and weighed. The mean result is 35.457, silver being 107.88. These values differ slightly from the 35.467 and 107.91 found recently by Prof. H. B. Dixon and Mr. E. C. Edgar by the same method.

ACCORDING to the February number of the Journal of the Röntgen Society, the committee of the society, which has under consideration the establishment of a standard unit of radio-activity, has made an interim report in which it recommends that 1 milligram of pure radium bromide be regarded as the standard, and that the ionisation produced by the γ rays from it, after passing through 1 centimetre of lead, be taken as a measure of the unit of radio-activity. There are, however, certain difficulties in the adoption of these suggestions which the committee has still under consideration, and will deal with in a future report.

THE Cambridge University Press has issued a fourth edition of "Petrology for Students: an Introduction to the

Study of Roëls under the Microscope," by Mr. Alfred Harker, F.R.S. The book has been revised, new figures have been added, and a few old ones have been withdrawn.

THE U.S. Department of Agriculture has issued, at the request of librarians and others interested in entomology, a complete list of the publications of the Bureau of Entomology and those of the Department of Agriculture in general bearing on the same subject, and published by members of the Bureau or under its auspices. The list has been compiled by the librarian, Miss Mabel Colcord.

A SECOND edition of "An Elementary Course of Practical Zoology," by the late Prof. T. Jeffery Parker and Prof. W. N. Parker, has been published by Messrs. Macmillan and Co., Ltd. The first edition was reviewed at length in the issue of NATURE for April 12, 1900 (vol. lxi., p. 559). In the present edition some parts have been slightly extended, and various modifications made throughout; in addition, short accounts have been introduced of Monocystis, Nereis, and Obelia, and several new figures added.

THE Carnegie Institution of Washington has published an "Index of Economic Material in Documents of the States of the United States; New York, 1789-1904." The index has been compiled by Mr. A. R. Hasse, of the New York Public Library, for the department of economics and sociology of the institution. The index runs to 553 large pages, and deals only with the printed reports of administrative officers, legislative committees, and special commissions of the States, and with governors' messages for the period since 1789.

OUR ASTRONOMICAL COLUMN.

COMET 1907d.—No. 4234 of the *Astronomische Nachrichten* (p. 159, February 22) contains Herr Kritzinger's continuation of his ephemeris for 'Daniel's' comet. At present the calculated magnitude of this object is about 10.8, and the comet is situated about 2° north of μ Virginis.

OBSERVATORY MAP OF THE MOON.—From Mr. Porthouse, of 6 Bates Street, Birch Lane, Longsight, Manchester, we have received a copy of his recently published map of the moon. This map is printed on a circle of 12 inches diameter, the different formations being shown very clearly in outline. At the side of the sheet is a printed list of the formations, with reference numbers and the diameters according to Neison. The map can be read easily in the dim light of the observatory, and can be obtained from the publisher for eightpence, post free.

THE RECENT MAXIMUM OF MIRA CEN.—From forty-one observations of Mira, made with an 8-inch telescope, a pair of field-glasses, and the naked eye, and extending from September 8, 1907, to January 20, M. Félix de Roy found that the maximum brightness occurred on November 1, 1907, with a magnitude of 3.41. From October 20 to November 4.5 the brightness of the star apparently remained constant. A comparison with M. Roy's observations of the 1906-7 maximum shows the period of fluctuation to be 318.5 days, some thirteen days shorter than it is given by Guthnick on the basis of the observations made during the last three centuries; other observers of the recent changes place the maximum at dates varying from October 30 to November 9.

According to Chandler's computations, a maximum of Mira Cygni was due to take place on April 4.5. On March 6 and 26, respectively, M. de Roy estimated the magnitudes of this object to be 6.60 and 5.88 (*Gazette astronomique*, No. 4, March 31).

SUN-SPOT OBSERVATIONS.—In No. 4257 of the *Astronomische Nachrichten* (p. 205, March 6), Herr T. Epstein compares the results of his sun-spot observations made during the years 1905, 1906, and 1907. The figures for

the half-years show that the maximum daily frequency took place in the second semester of 1905, and the yearly values indicate a steady decrease during 1906 and 1907. The ratio of the number of groups in the northern to the number in the southern hemisphere was almost reversed during 1907, for whereas in 1906 it was 1.55:1, in 1907 it was 1:1.28.

MERIDIAN CIRCLE OBSERVATIONS OF PARALLAX STARS.—Lick Observatory Bulletin, No. 129, contains a list of forty-five stars which have been observed at the request of Dr. L. de Ball for use in his heliometer measures of parallax. The positions given are the results of 400 observations, made on twenty-five nights, by Prof. R. H. Tucker.

THE RECENT TOTAL SOLAR ECLIPSE.—From a note in No. 1, vol. ii., of the Journal of the Royal Astronomical Society (Canada), we learn that the Lick Observatory eclipse party arrived back at Mount Hamilton on January 25. Rain fell during a part of the total phase, but some good photographs were obtained, for although the instruments were wet, they worked perfectly.

A NEW EXPEDITION TO THE SOUTHERN HEMISPHERE.—With the object of extending Prof. Boss's fundamental catalogue work to the southern hemisphere, an expedition, under the direction of Prof. R. H. Tucker, of the Lick Observatory, is to be dispatched to either New Zealand, South America, or South Africa. The Carnegie Institution has offered to bear the expense of the proposed observatory, and it is expected that the work will take about three years to carry out. The large Pistor and Martins meridian circle of the Dudley Observatory (Albany, U.S.A.) will be employed for this work (*Journal R.A.S.*, Canada, vol. iii., No. 1, p. 43).

THE HAMBURG OBSERVATORY.—Prof. Schorr's report of the Hamburg Observatory, for 1906, contains an account of the new buildings and instruments. The new observatory lies about 20 kilometres to the south-east of the present one, and is at an altitude of 40 metres above the Elbe. The buildings are in the shape of a T, and cover an area of 33,650 square metres. Among the new instruments is a Steinheil refractor of 60 cm. aperture and 9 m. focal length, to which is adapted a correcting lens for the purpose of photography, and a meridian circle of 19 cm. aperture and 2.3 m. focal length; the circles are of 74 cm. diameter, and are divided in 4' intervals. Reports, in brief, of the 1905 and 1907 eclipse expeditions and of the variable-star observations and time-service are also given in the volume.

THE ZIEGLER POLAR EXPEDITION.¹

IN the introduction Mr. Fiala gives a somewhat scanty historical account of the expedition, a footnote referring the reader for details to his popular narrative "Fighting the Polar Ice." One gathers that the expedition was equipped by Mr. W. Ziegler, of New York—who died before its return—and that the vessel which conveyed the expedition to its objective, Franz Josef Land, in 1903 was lost, the party being eventually rescued in 1905.

Mr. Ziegler had the sagacity to leave the choice of a scientific leader to the National Geographic Society, and its selection of Mr. Peters seems justified by the results. Mr. Peters was himself to have prepared the scientific results for press, but shortly after his return to America he was appointed to the magnetic survey ship of the Carnegie Institution, and his duties as editor devolved on Mr. J. A. Fleming. The magnetic instruments, a unifilar magnetometer and a dip circle, were loaned by the U.S. Coast and Geodetic Survey, and a programme was prepared by Dr. L. A. Bauer. Meteorological instruments were lent by the U.S. Weather Bureau and the U.S. Signal Corps, and the completeness of the records obtained probably owes a good deal to the fact that one of the members of the expedition, Mr. Francis Long, was a trained observer of the U.S. Weather Bureau.

¹ "The Ziegler Polar Expedition 1903-5," Anthony Fiala, Commander. Scientific Results obtained under the direction of William J. Peters. Edited by John A. Fleming. Pp. vii+630; with maps. (Washington, D.C. Published under the auspices of the National Geographic Society, 1907.)

The results appear under six sections:—magnetic, pp. 1-360; auroral, pp. 361-8; meteorological, pp. 369-488; tidal, pp. 489-590; astronomical, pp. 597-622; and map construction and survey work, pp. 623-630. The pocket at the end contains a map of the Polar regions down to latitude 65°, indicating the routes of the chief Polar expeditions, and two charts of Franz Josef Land, one of the whole archipelago and the other of the part surveyed by the Ziegler expedition.

The magnetic work consisted mainly of observations at Camp Abruzzi, Teplitz Bay (81° 47' 5" N. lat., 57° 59' E. long.), from September 28, 1903, to July 1, 1904, and at Camp Ziegler, Alger Island (81° 21' 5" N. lat., 56° 5' E. long.), from June 26 to July 30, 1905. Miscellaneous observations were also taken at Tromsø, Archangel, Barents Sea, and en route from Teplitz Bay to Cape Flora. Teplitz Bay, in Rudolph Island, is in the extreme north of the group of islands forming Franz Josef Land; it was the station occupied by the Duke of the Abruzzi's Italian expedition in 1899-1900. Alger Island is towards the south of the group, while Cape Flora, in Northbrook Island (the site of the Jackson-Harmsworth expedition), is in the extreme south. Fig. 1 (from p. 604) shows the nature of the observatory at Teplitz Bay. Prefaced to the magnetic observations is a condensed narrative relating mainly to auroral appearances and observational details, but occasionally of more general interest, as the following extract from the February, 1904, record will show:—

"12:20:00 sky clear, no aurora; 12:22:56 bear trying to break into observatory; 12:23:20 aurora in south-east; 12:23:40 to 48 observer investigating outside to see if bear is gone." For some time after this incident the observer, following the example of the Nansen expedition, provided himself with a revolver, the presence of which is conscientiously recorded. Considering the absence of self-recording instruments, the magnetic results obtained are, thanks to Dr. Bauer's programme, remarkably extensive. Eye readings of the declination magnet were carried out, so far as the exigencies of the situation permitted, on the following plan. On one day each week readings were taken at two-minute intervals throughout the whole twenty-four hours; on a second day similar observations were made for eight hours, and on each of four other days for four hours. The observations on these last five days were so arranged as to cover all hours of the day; thus results were obtained in each week answering to observations at two-minute intervals for two complete days. Diurnal inequalities of declination were formed for each four-week period at Teplitz Bay, each hourly value being a mean from 4x2x30, or 240, readings. These inequalities are analysed in Fourier series and illustrated by curves. During the nine months at Teplitz Bay, the range of the regular diurnal inequality varied from 107.1 in June to 26.3 in February-March. The mean of the ranges from the two four-week periods November 29 to December 26 and December 27 to January 23 was 36.7. The existence of so large a range in the Arctic mid-winter is noteworthy. Throughout the whole time the general character of the diurnal variation was an easterly movement (of the north end of the magnet) from about 8 p.m. to 5 a.m. The return movement to the west was fairly continuous and rapid in summer, but in winter there was usually a secondary east and west movement in the afternoon. The greater rapidity of the movement during the day, so characteristic in temperate latitudes, seems not to exist at Teplitz Bay except at mid-summer. The corresponding analytical feature is the relatively small amplitude of the twelve-hour Fourier wave. The diurnal inequality of declination observed at Alger Island in June-July, 1905, had a somewhat smaller

range, but was generally similar to that observed at Teplitz Bay at the previous mid-summer. A satisfactory feature in connection with the declination observations is the frequency and consistency of the determinations of the true bearing of the distant marks employed.

More than fifty absolute observations of horizontal force and more than sixty observations of inclination (with two needles) were made at Teplitz Bay; at Alger Island there were sixteen observations of horizontal force and eight of inclination.

In accordance with the experience of previous Arctic observers, it was found that whilst magnetic storms and aurora were generally associated together, this was not always the case. Declination observations happened, fortunately, to be taken on November 1, 1903, during part of the great magnetic storm then in progress. In the course of 1h. 48m. the declination changed by 17° 18', or some thirty-two times the corresponding change at the Cheltenham Observatory (where the horizontal force is about three times that at Teplitz Bay). If the same proportion existed throughout the rest of the storm, the declination range at Teplitz Bay must have exceeded 50°.

The auroral data are mainly descriptive, and there is no attempt at trigonometrical observations or tabular details. There are, however, nineteen handsome plates,



FIG. 1.—Exterior of Observatory at Teplitz Bay.

based on chalk sketches made by Mr. Fiala, illustrating a number of auroral types, especially the corona. Plates VII. and VIII. show banded structures having in some respects a somewhat striking resemblance to those produced artificially by Villard.

Of the meteorological observations, the longest series consists of hourly records of wind velocities from a Robinson cup anemometer at Teplitz Bay from September, 1903, to May, 1905. Allowing for possible differences between American and English estimates of wind velocity, we may safely characterise Teplitz Bay as a windy place. The average velocity for the whole period was 14.6 miles per hour. Monthly means varied from 8.2 in August, 1904, to 24.2 in February, 1905, and 24.6 in December, 1903. On four days the mean hourly velocity exceeded sixty; on December 28, 1903, the mean velocity was no less than 73.4 miles per hour. In winter, high gales were associated with a low barometer and a high temperature. Changes of temperature were notably large and rapid. Eye readings were taken thrice a day, at 8 a.m., noon, and 8 p.m., of barometric pressure, temperature (from ordinary and from maximum and minimum thermometers), precipitation, wind (velocity and direction), and cloud (amount, species, direction of motion). These observa-

¹ NATURE, vol. LXVI., p. 481.

tions lasted at Teplitz Bay from September 1, 1903, to April 30, 1904, and at Cape Flora from May 21, 1904, to July 30, 1905. Taking the mean of the three daily readings, the monthly mean temperature varied at Cape Flora from $-19^{\circ}9$ F. in January to $+35^{\circ}6$ in July; at Teplitz Bay, March had the lowest mean temperature, $-19^{\circ}7$ F. At Cape Flora, the precipitation during the year ending with May, 1905, was equivalent to 21.37 inches of rain. A recording thermograph and barograph were in action at Teplitz Bay from October, 1903, to April, 1904, and a barograph was run at Cape Flora from June, 1904, to May, 1905. From the records of these instruments diurnal inequalities are deduced for individual months, and Fourier coefficients calculated. Taking arithmetic means from individual months, the amplitudes (in thousandths of an inch) of the three first terms in the case of the barometric pressure were:—

	24-hour	12-hour	8-hour
Teplitz Bay (winter)...	14	6	3
Cape Flora (year) ...	13	5	3

Tidal observations were made at Teplitz Bay from April 1 to June 3, 1904, and at Cape Flora from May 21 to August 31, 1904. Readings, to 0.01 foot, were taken on a tide staff once an hour, usually throughout the whole twenty-four hours. Fig. 2, reproduced from p. 493, shows the arrangements at Teplitz Bay. The wooden frame

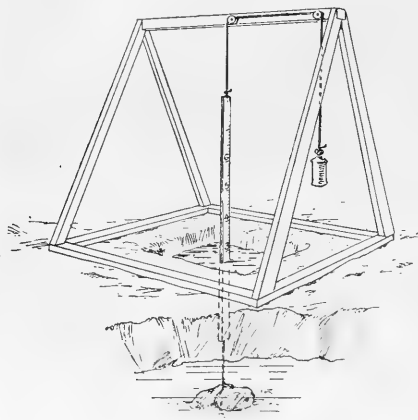

FIG. 2.—Tide Gauge at Teplitz Bay.

rose and fell with the ice it rested on, the heavy stone remaining on the sea bottom. There is an elaborate harmonic analysis of the data, following generally the methods of Sir G. H. Darwin. The mean difference between high-water and low-water level was fairly similar at the two stations, being 1.138 feet at Teplitz Bay and 0.966 foot at Cape Flora. There was, however, a difference of $\frac{3}{4}$ hours in the "establishment of the port" at the two places, and the conclusion is drawn (p. 596) that the tide from the Atlantic reaches Franz Josef Land by two channels, the deeper, between Spitsbergen and Greenland, chiefly influencing Teplitz Bay, the other, between Spitsbergen and Norway, chiefly influencing Cape Flora.

The astronomical observations served to fix the latitude and longitude of the stations and the azimuths of the declination marks. Considerable care was evidently given to them, but they call for no special remark.

As will have already been inferred, one can have nothing but praise for the zeal displayed. Magnetic observers who took observations at two-minute intervals for eight hours on end, at temperatures below 0° F., cannot be accused of treating Arctic exploration as a pretence for a picnic. It may also be added that no trouble has been spared in making the most of the material collected. Valuable, however, as the results are, they must be accepted with

several reservations. As the dates will have shown, the series of observations, especially the tidal ones, were short, and the representative nature of the results is thus exposed to more or less doubt. This consideration cannot but suggest itself to anyone who examines some of the data critically. Taking, for instance, the mean monthly data from the thermograph record at Teplitz Bay, we find that in March the 10 p.m., midnight, and 2 a.m. readings are the only ones of the two-hour readings to exceed the mean for the day, the maximum coming at 2 a.m.; and in April these are the precise hours to which the lowest temperatures are attached. Again, the diurnal inequality range is $3^{\circ}3$ in January, in the depth of the Arctic night, but only $0^{\circ}8$ in October. In the case of the magnetic data, there are other sources of uncertainty. There was appreciable local disturbance both at Teplitz Bay and Alger Island, and its precise effect, though probably not large, cannot be assigned. After the return of the magnetometer to America it was found that a cloth hood, believed to have been fastened to the end of the magnet box in 1899, had been attached with steel tacks. Observations at Cheltenham showed no effect on the declination, but a decrease of 250 γ ($1 \gamma = 0.00001$ C.G.S.) in the horizontal force. A correction of +255 γ (or nearly 4 per cent.) was thence calculated and applied to observations made in the Arctic. In the case of the dip circle comparisons at Cheltenham before the expedition gave for the two needles corrections of only $+0^{\circ}2$ and $-0^{\circ}3$, but the corresponding corrections obtained after the expedition were $-4^{\circ}1$ and $-5^{\circ}6$.

In view of these uncertainties, and the lack of direct information as to diurnal change, the deductions made as to secular changes of horizontal force and inclination at Teplitz Bay by comparison with the results of the Italian observers for 1900 should be regarded with reserve.

Again, at Teplitz Bay there were only nine months' magnetic observations, and the deductions of diurnal inequalities for the three missing months, and thence for the year as a whole, are of somewhat doubtful value.

The deficiencies referred to are such as attach more or less to most expeditions, and there are probably few Polar observations which are not affected by at least as serious uncertainties. There are many points in connection with the observational programme and its execution which merit the attention of those contemplating magnetic or meteorological work in high latitudes.

C. CHREE.

SANATORIA FOR CONSUMPTION.

AS a supplement to the thirty-fifth annual report of the Local Government Board, Dr. Bulstrode has published an imposing volume on "Sanatoria for Consumption and certain other Aspects of the Tuberculosis Question." This report, copiously illustrated by photographs, plans, and charts, extends to 700 pages, and is an admirable exposition of the present position of the problem of prevention of tuberculosis.

In part i. is set forth a general review of the changes which have taken place in medical opinion as to the etiology of tuberculosis and as to the mode of its invasion of the human body.

The theory of infection by inhalation of dust infected by dried sputum, and the evidence on which it is based, is reviewed; also the theory of von Behring that infection can be usually traced to the ingestion of tuberculous milk in infancy, remaining latent until some debilitating influence causes the focus of infection to light up to the undoing of the organism. Calmette's theory that direct infection occurs mainly by the ingestion of food tainted by droplets of infective expectoration is also discussed, and finally we have the conclusions of the Royal Commission on Tuberculosis, that a material amount of human tuberculosis is attributable to infection of the intestinal tract by "tubercle of bovine origin."

The proportion of tuberculosis due to this source, unfortunately, has never been definitely ascertained, but the pronouncement of the Royal Commission is important in the light of Koch's dogmatic statements as to the essential difference between human and bovine tubercle, and all this difference entails.

Dr. Bulstrode gives us many tables of statistics which prove the gradual but steady diminution of tuberculosis, and emphasise the curious phenomenon that this declension is much more marked among females.

In this satisfactory state of affairs sanitary reform, improved conditions of living, and higher wages have all played their part, but the report does not help us much to estimate the relative value of the various methods of attacking the disease which have been tried.

The difficulty of estimating the value of sanatorium treatment is brought out, and we are told that until this method has had a longer trial figures of results will only lead to confusion and misconception.

Stress is, however, laid on the fact that to obtain the best results from sanatorium treatment cases of tuberculosis must be treated in their earliest stages, and further, that after treatment an easy path of suitable work must be provided until a life of full activity can be tolerated by the patient.

The problems which arise in the selection of a sanatorium site, and the conditions necessary in sanatorium buildings, are thoroughly discussed. Dr. Bulstrode concludes that, with foresight and care, the erection of sanatoria with all actual essentials might be provided at a smaller cost than has hitherto been the case. This is an important conclusion, for if we are to provide adequately for the tuberculous population, many more sanatoria must be erected, and the question of money has ever been the chief difficulty in the way.

One of the most interesting chapters, which is amplified in part iv., relates to the German system of compulsory insurance as a factor in the control of phthisis. The figures given are striking, and we see here admirably exemplified the value of co-ordinated effort as opposed to the haphazard methods of control employed in the British Isles.

The conclusion is thrust upon us that in the control of phthisis Germany is far ahead of us. We are set an excellent example, which we would do well to follow. Our comparative failure is largely due to this want of co-ordination, and the waste of money and energy thereby entailed.

This part of the report concludes with a chapter on the teaching of hygiene in the public elementary schools. Tuberculosis is associated with ignorance no less than with poverty, so that there can be no question as to the importance of teaching elementary hygiene, especially so far as food values are concerned, as a means to the reduction of tuberculosis both in childhood and adult life.

In part ii. we are given a well-illustrated directory of all the public sanatoria in England and Wales, which should prove of much value for reference. This part of the report has been provided with an index, which might mercifully have been extended to the whole volume.

Part iii. is devoted to a discussion of notification of tuberculosis (voluntary and compulsory). There are as yet no data available by which the substantial utility of notification can be tested, and we must await a more extended experience before a decided opinion can be formed.

The whole volume is an admirable and comprehensive piece of work, which should be read by all those interested directly or indirectly in the problems of tuberculosis.

R. FIELDING-OULD.

THE SOCIETY OF DYERS AND COLOURISTS.

THE twenty-fourth annual general meeting of the Society of Dyers and Colourists was held at Bradford on Friday, April 3, in the large hall of the Technical College. The president, Prof. Meldola, having taken the chair, the Lord Mayor of Bradford, on behalf of the town, welcomed the meeting, and especially the distinguished foreign visitors, Prof. Liebermann and Dr. Schreiner, who were present. The president then, on behalf of the society, awarded the Perkin medal, which for this occasion had been duplicated, to Profs. Graebe and Liebermann for their synthesis of alizarin in 1868. The medal was founded by the society in 1906 in honour of the late Sir William Perkin, and in celebration of the jubilee of the discovery of mauve, the

first of the coal-tar colouring matters, the terms of its award being "for investigations, discoveries or inventions of high scientific or industrial importance applicable to or connected with the tinctorial industries."

In presenting the medals, which Prof. Liebermann received on behalf of himself and colleague, the president pointed out that this first presentation was in recognition of a discovery which, although made forty years ago, was still practically effective in enabling the tinctorial industry to be supplied with some of the most important of the artificial colouring matters. The synthesis of alizarin was of extreme scientific interest as having been the first case of the artificial production of a natural colouring matter, and it was also of particular importance as having exerted a marked influence on Perkin's career as a manufacturer and scientific investigator. Prof. Liebermann, on behalf of Prof. Graebe and himself, acknowledged the honour which had been conferred upon them, and in eloquent terms paid tribute to the memory of the late Sir William Perkin.

The president then delivered an address on the founding of the coal-tar colour industry, in which he reviewed Perkin's life-work from the technical side, and gave a history of the foundation and development of the Greenford Green factory, where all Perkin's industrial operations were conducted. On the motion of Mr. Hindley, seconded by Dr. Hertz and supported by Sir Robert Pullar, the president was thanked for his address, which was ordered to be published in the journal of the society.

In the evening the members and their guests dined at the Great Northern Victoria Hotel, the president occupying the chair, and being supported by Prof. Liebermann, the Lord Mayor, the ex-Lord Mayor, Sir Robert Pullar, Dr. C. Dreyfus, and representatives of most of the great dyeing and printing firms of the district, as well as by well-known authorities connected with the educational and scientific side of the tinctorial industry, such as Profs. A. G. Green (Leeds), W. M. Gardner (Bradford), Dr. J. C. Cain (London), Dr. Knecht (Manchester), and Mr. C. Rawson (Leicester), &c. All the officers of the society, which has its headquarters in Bradford, with sections in Manchester, the West Riding, and London, were also present. The toast of the society was proposed by the Lord Mayor, and responded to by Sir Robert Pullar. The president gave the toast of the medalists, which was enthusiastically received in both German and English forms, and to which Prof. Liebermann responded. The toast of the president was proposed by Mr. Ald. Godwin, the ex-Lord Mayor, in a humorous speech, and replied to by the chair. Dr. Schreiner, the inventor of the well-known process for "Schreinerising" fabrics, also addressed the meeting in acknowledgment of the honour done to his distinguished countrymen and to himself as a guest. As Prof. Graebe was unable through indisposition to be present at the gathering, a telegram was dispatched in the name of the society expressing regret at his absence and wishes for his speedy recovery.

ENCKE'S COMET.

THE observations of Encke's comet made at the Heidelberg Observatory deviate so strongly from the predicted places that Dr. Backlund, the director of the Pulkova Observatory, has thought it necessary to investigate the cause. He finds that the perturbations by Jupiter, which were calculated in duplicate by H. Kamensky and Fraulein Karolikowa, have been correctly applied, so far as they depend on the first power of the disturbing force, but that in the period 1901-4 the comet approached Jupiter almost as closely as is possible, and that in consequence perturbations of the second order are very sensible. The corrections to the several elements, depending on the action of Jupiter, were as follows:—

	1st Order	2nd Order
Mean anomaly	+11 55.2	-3 34.1
Long. perihelion	-0 8.5	-0 15.7
Long. node	+0 4.8	-1 0.2
Inclination	+1 2.0	—
Excentricity	+2 39.8	-1 7.6
Mean motion	+0.9255	-0.3210

The corrections to the ephemeris, after applying the improved value of the perturbations, and taking into

account the influence of the acceleration, are, for the three days:—

	1908, Jan. 3	Jan. 11	Jan. 19
$\Delta\alpha$...	+0 49'25	+0 40'31	+0 27'50
$\Delta\delta$...	-2 24'75	-2 21'69	-2 21'65

whereas the corrections to the published ephemeris, found by Dr. Kobold from Dr. Max Wolf's observations, are of quite a different character:—

	$\Delta\alpha$	$\Delta\delta$
1907 Dec. 25	+34'5	-24
1908 Jan. 2	+35'2	-24
" " 13	+47'0	-4'9
" " 14	+47'2	-3'6
" " 15	+47'0	-2'4
" " 18	+45'3	+0'5
" " 19	+44'3	+1'4

It will be seen that the neglected perturbations in no way explain the deviations between the computed and observed places. In declination these differences are particularly striking, and no permissible alterations to the elements will reduce them to the order of errors of observation.

Prof. Backlund makes two suggestions by way of explanation:—(1) that the object observed from December 25 to January 19 was not Encke's comet; (2) that this comet has divided itself into two parts, and that the part that has been observed has, by the process of dislocation, been deflected from the original orbit. Observations in the southern hemisphere, which will be possible in June, will decide this point. Dr. Backlund further points out that, previous to this year, the comet has never been observed before perihelion passage when the date of perihelion falls between April and July.

Dr. Ebell has computed a parabolic orbit from the observations made at Heidelberg, and the result is sufficiently surprising. The dates selected were January 2, 13, and 19, and the middle place is fairly well represented, but the outstanding errors on December 25 were $\Delta\alpha+32'.40$ and $\Delta\delta+12'.19$. The elements are as follows:—

T ...	1907 Dec. 6'0569	Berlin M. T.
ω ...	39 25'59	} 1908 ^o
Ω ...	317 7'25	
i ...	10 26'09	
$\log q$...	0'58448	

The node and inclination are not very different from those of Encke, but the perihelion distance is rivalled only by the comet of 1720. The material is not sufficient to derive an ellipse. It will probably be found that the Heidelberg object is not the comet of Encke.

UNIVERSITY AND EDUCATIONAL INTELLIGENCE.

LONDON.—The report of the committee of University College for the year 1907-8 has just been issued. During last session there were 1191 students, of whom 171 were registered as post-graduate and research students. The report deals, among other matters, with the work of the faculties for the past year, and gives a list of the researches and original papers published during that year. That list occupies thirteen octavo pages. Among the departments that seem to have been specially productive may be noted the department of applied mathematics under Prof. Karl Pearson, from which no fewer than twenty-eight papers were issued during the year. Seven of these were from the Francis Galton Laboratory of National Eugenics. The departments of chemistry under Sir William Ramsay and Prof. J. Norman Collie produced twenty-four original papers, while the subdepartment of spectroscopy issued seven. The list of post-graduate courses is valuable as an indication of the extensive provision for higher work that is now to be found in London. The report concludes with a summary of the urgent needs

of the college if it is to meet the demands made upon it; they include the following:—

	Estimated Cost	Money Available
New buildings for anatomy, physiology, and pharmacology	£ 50,000	£ 15,250
New buildings for the department of chemistry. (The scheme could be carried out in two sections, costing 40,000l. and 30,000l. respectively)	70,000	nil
Building alterations and new equipment for botany and pathological chemistry	5,000	nil
Re-fitting of general library and completion of science library	5,000	nil

Dr. J. M. FORTESCUE BRICKDALE has been appointed director of the public health laboratory of University College, Bristol.

THE Fishmongers' Company has given 1000l. towards the fund for carrying out the scheme of incorporation of King's College with the University of London.

MR. CARNEGIE has given a further donation of a million pounds sterling to the Carnegie Foundation for the Advancement of Teaching. Attention was directed in our issue of March 12 (p. 452) to the admirable work done already by the foundation, which was two years ago inaugurated by Mr. Carnegie and endowed by him with two millions sterling. The fund, which now amounts to 3,000,000l., is intended primarily to serve for providing retiring allowances for professors and others in universities and colleges in the United States, Canada, and Newfoundland. Originally the benefits of the foundation were confined to privately endowed educational institutions, and Mr. Carnegie has increased the fund so that professors in State institutions may also be eligible to participate in the benefits of the scheme.

The seventy-fourth annual report of Bootham School (York) Natural History, Literary, and Polytechnic Society, that for 1907, provides excellent evidence that in some English secondary schools at least the out-of-school hours are opportunities in which the boys may follow their natural bent and cultivate their individuality. The boys band themselves together in societies for the outdoor study of numerous branches of natural history; they record meteorological data, study the archeology of the neighbourhood, practise photography, work in metal and wood, and besides these and other practical pursuits they take part in a flourishing literary society. Boys and masters are to be congratulated upon the report, and the boys also on the fact that they are allowed to manage the societies largely by themselves.

It is well known, says the Journal of the Royal Society of Arts, that American employers give much more attention than has been the practice in this country to affording facilities to their managers and workpeople for obtaining technical knowledge. For example, a large organisation of spinners and manufacturers at Atlanta (Georgia) has adopted the following scheme for keeping their employees up to date in commercial and technical knowledge of the textile trade. A librarian is employed to secure all the latest books dealing with spinning, weaving, and textile engineering; all periodicals from all parts of the world bearing on the subjects are purchased or otherwise secured. The librarian prepares brief descriptions of the books, to which anyone may refer to get a quick idea of the contents. In some instances the whole periodical is filed; in others special articles are cut out, and sometimes foreign articles are translated and pasted in scrap-books. Everything is carefully indexed, and the library is open to any employee.

A NATURE-STUDY course for women is to be given again this year at the Horticultural College, Swanley, Kent, during the summer holidays. The course will extend from August 1 to 12. Weather permitting, most of the instruc-

tion will be given out of doors, rambles in the country under the guidance of experienced teachers being the chief feature. It is hoped to combine the natural history excursions with points of antiquarian and other interest in outlying districts, and an endeavour will be made to render the course useful, both for home life and school work. The report for 1907 on the work of the college as a whole shows that good progress continues to be made. The chief feature of the year was the establishment of a course in natural history, which has for its object the training of third-year students who have passed the ordinary gardening course at the college and wish to increase their knowledge of natural history subjects in order to qualify as teachers of gardening and nature-study.

The third International Congress for the Development of Drawing and Art Teaching is to be held in London from August 3 to 8 next. Previous meetings in Paris in 1900 and in Berne in 1904 proved very successful in stimulating the application of art to industry. The promoters of the London meeting direct attention to the fact that as a nation Great Britain compares unfavourably with her commercial competitors in the attention paid to applied art in technical schools. On these grounds, with others, an appeal is made to educational authorities and employers of labour to assist in making the forthcoming congress a success, both by contributions to the necessary funds and by interesting administrators and teachers in the scheme. Drawing should be allied with all subjects of study, but it is especially useful to the student of science, and it is to be hoped that the congress will lead to an improvement in the methods of teaching drawing in our schools, as well as to a recognition of its importance in a complete scheme of education. Full particulars of the London meeting can be obtained from the secretary of the congress, 151 Cannon Street, London, E.C.

The second International Congress of Popular Education is to be held in Paris from October 1 to 4 next. It is being arranged by la Ligue française de l'Enseignement. Invitations have been sent to various educational associations in different parts of the world to send delegates to the congress. All expenses in connection with the congress are to be borne, we understand, by the league. Among the subjects to be introduced and discussed at the meetings in Paris may be mentioned:—Societies for the encouragement of the education of the masses, popular lectures and libraries, the education of women in household and maternal duties, professional education, the international exchange of children for educational purposes, and the system of visits by teachers for the study of foreign methods. It is hoped to publish the addresses and discussions at the congress, and in this way to bring together much valuable experience gained in different countries in the direction of solving difficult educational problems. There is every reason to hope that the meetings will prove even more successful than those of the first congress, held at Milan in 1906. All inquiries should be addressed to M. Léon Robelin, general secretary of la Ligue française de l'Enseignement, 16, rue de Miromesnil, Paris.

The accounts for the year ending July 31, 1907, of the various London polytechnics show that the total ordinary receipts of all the institutions amounted for the year to 203,052*l.* The grants of the London County Council amounted to 77,358*l.*, or 37.93 per cent. of the total receipts. Grants from the Board of Education reached 32,847*l.*, or 16.11 per cent.; the amounts received from City Parochial Foundation were 28,330*l.*, or 13.89 per cent., and from City companies, &c., 5917*l.*, or 2.90 per cent. The total ordinary expenditure on revenue account of all the institutions amounted to 207,510*l.* Large increases occurred under two heads, *viz.* "teachers' salaries," 10,317*l.*, and "apparatus and other educational appliances and furniture," 3116*l.* Taking the results as shown by the accounts, it is seen that, so far as ordinary income and expenditure are concerned, there was a deficit of 3567*l.* on the institutions as a whole. With regard to items of an exceptional nature—principally new building works and special equipment—the total income was 15,089*l.*, of which the London County Council's grants amounted to 9401*l.*, and the expenditure was 9113*l.* Of

the total amount of revenue, it is interesting to note that the fees of students and members of the various polytechnics amounted in all to 47,253*l.*, or 21.57 per cent., and what are called in the accounts voluntary subscriptions reached 9161*l.*, or 4.18 per cent., nearly twice as much as in the previous year, though other percentages were practically the same in both years.

SOCIETIES AND ACADEMIES.

LONDON.

♣ **Royal Society, December 5, 1907.**—"On the Structure of *Sigillaria scutellata*, Brongn., and other Eusigillarian Stems, in Comparison with those of other Palaeozoic Lycopods." By E. A. Newell Arber and Hugh H. Thomas. Communicated by Dr. D. H. Scott, F.R.S.

This paper contains the first full account of the structure of the Eusigillariæ or ribbed Sigillarias of the Rhytidolepis section. The stele has a well-marked pith, bounded by a continuous ring of scalariform tracheids—the primary wood—the outer margin of which is crenulated. The ribs are really formed of cortical tissues, and not by fused leaf-bases. They consist largely of pheloderm, and externally what is probably a small zone of primary cortex, which lay without the region of secondary meristematic activity, still persists. The leaf-bases, consisting of thin-walled parenchymatous elements, merely form bracket-like projections from the ribs.

The presence of a ligule and a ligular pit has been detected for the first time. The course of the leaf-traces in the leaf-bases and cortical tissues has been followed with important results. The bundle is collateral, and without secondary wood. In the leaf-bases the trace consists of a *double xylem strand*, the two xylem groups being widely separated. These two strands unite as they pass through the pheloderm. The structure of the trace is almost identical with the foliar bundle of the leaf *Sigillarioopsis sulcata*, which is obviously simply the leaf of a eusigillarian stem.

The pithnos increases greatly in size as we pass from the exterior of the stem to the inner margin of the periderm. The two strands further unite, first below and then above the trace, so that, at a deep level in the periderm, the trace is completely surrounded by a broad zone of this tissue.

January 16.—"The Conversion of Diamond into Coke in High Vacuum by Kathode Rays." By the Hon. C. A. Parsons, C.B., F.R.S., and Alan A. Campbell Swinton.

The apparatus employed consisted of a Crookes tube furnished with two concave cup electrodes of aluminium which, when supplied with high-tension alternating current, acted alternately as cathode and anode, and accurately focussed the kathode rays on to the diamond, which was supported on a plate of iridium.

As the proper degree of vacuum was reached by means of mercury pumps, and as the volts were raised, the diamond in each of the two experiments made became red, and then intensely white hot, until with about 9600 volts and 45 milliamperes passing through the tube it commenced to become black.

Finally, with 11,200 volts and 48 milliamperes (537 watts), a rapid disintegration of the diamond took place with considerable increase in volume, the residue having much the appearance and consistency of coke. As measured by a Féry optical pyrometer, the disintegration took place at the temperature of 1800° C.

Observations of the spectra of the residual gases in the tube before and after the conversion of the diamond into coke showed differences, but these were not thought sufficiently marked to determine with exactitude any variation in the nature of the gases present.

January 23.—"Report on the Eruptions of the Soufrière in St. Vincent, 1902, and on a Visit to Montagne Pelée in Martinique. Part II.—The Changes in the Districts and the Subsequent History of the Volcanoes." By Dr. Tempest Anderson. Communicated by Prof. T. G. Bonney, F.R.S.

The principal points of interest in the observations made

during the author's second visit lie in (1) the changes wrought by denudation on the deposits left by that eruption; (2) the light thrown by those changes on the operation of the forces which had moulded the features of this island in its earlier history; (3) the information he was able to collect with regard to the volcanic disturbances subsequent to the great eruption of May, 1902; and (4) the return of vegetation to the devastated areas.

In the 1902 eruption a certain amount of the ejecta overtopped the Somma ring, i.e. the remains of the original great crater, and descended some of the valleys to the north of it; but by far the greater portion was discharged into the transverse depression which extends right across the island and separates the Soufrière from the mountain known as Morne Garu, about three miles to the south. The water from the crater lake was discharged at the beginning of the eruption down the Kabaka and Wallibu rivers, while the solid and gaseous ejecta, in the form of the incandescent avalanches and black clouds, descended to both sides of the island.

The most important geological phenomena were observed in the Wallibu district. These phenomena have been fully described in the published report, as also the subsidence of part of the coast. To this district, therefore, attention was especially directed in 1907 with the view of observing the further progress of the changes and the return of vegetation.

A description of the Wallibu valley is given in the full paper. In that district the beds of newer date have been dissected into flat-topped plateaux by small rivers running in deep gorges, which have again been filled in places by ejecta of eruptions and re-excavated in different degrees, and sometimes on different lines, leaving plateaux and terraces of different ages and heights. This action is well exemplified in the lower valley of the Wallibu. In the 1902 eruption this part of the valley was filled by the incandescent avalanche to a depth of at least 100 feet in the upper part, and less towards the sea, and it was in this deposit of hot ash that the explosions of steam and hot ash, flows of boiling mud, and other secondary phenomena took place. In 1907 almost the whole of this ash had been washed away, but a fragment remained in the shape of a terrace 60 feet to 80 feet high, situated on the north side of the valley. The ash of which it is formed is unstratified, and contains very few ejected blocks or fragments of any kind. The floor of the valley is all composed of water-sorted material, chiefly gravel and coarse sand, but with a good many blocks as big as a man's head. They represent ejected blocks and fragments of lava derived partly from the ash of 1902 and partly from older beds, the fine ash in each case having been washed away. The surface of the gravel bed showed marks of quite recent running water, and during the last winter, 1906-7, the river ran along the foot of the north bank of the valley. When examined in March, 1907, it ran along the south side of the valley, and had already in those few months excavated a new channel about 30 feet in depth. The stratification, as exposed in the side of this new valley, is very distinct, and the sorting by water, mentioned above, is very evident. Further up the mountain the remains of the avalanche became more abundant in the valley bottoms, and here they were also often better preserved, so that traces of the feather pattern erosion, so noticeable in 1902, were still visible on the surface. This was mainly due to the surface of these ash deposits, like those to be presently mentioned on the plateaux and on the ridges, having consolidated into a crust almost like a cement pavement which resists the action of the rain.

Another interesting point was observed with regard to these massive ash deposits. Instead of one stream re-establishing itself along the centre of the deposit, the tendency is for a new stream to form on each side at or near the junction of the new ash with the old valley slopes; and, as these streams deepen themselves, two new valleys are formed where only one previously existed, and the walls of each are composed on the one side of the new ash and on the other of older tuff, with occasional terraces of new ash. It appears to be due to the fact that the water from the old slopes, in running down into the original valley, meets the soft new ash, and at once

turns down along the valley and so starts the new stream, and it seems likely that the chief cause of its so turning is that the surface of the deposit tends to be higher along the middle of the valley than at the sides, as is usual with mud-streams or glaciers. A good example of the action above described is to be found in a wide valley to the north of and parallel with the lower Wallibu valley, and bounded on the south by the Wallibu plateau. Before the 1812 eruption the Wallibu river flowed down this valley, but its course was changed after that eruption. The floor of the valley is now occupied by the gorges of two small rivers, divided by a very narrow ridge, formed of ash different from and less consolidated than that composing the walls of the main valley, and considerably lower than the Wallibu plateau. In 1902 both these gorges were filled with new ash to the level of the main valley floor. One of these, the Trespé gorge, now emptied of the 1902 ash, shows its north wall to be much higher than the south, and also formed of older and more consolidated tuff. The same conditions, with sides reversed, are seen in the other gorge, the higher bank in that case being the Wallibu plateau to the south.

The Wallibu plateau is composed of ash older than that dividing the above two small rivers, but still comparatively new, and its flat top and precipitous sides, both north and south, proclaim it to be in an early stage of denudation, while the south bank of the Wallibu river on the south of the plateau is composed of older tuff and lava, and shows a much more mature type of denudation, viz. sloping hills with rounded or ridged tops, and a good deal weathered into valleys or gullies. The north face of the plateau, like the south, is precipitous, and obviously much less advanced in weathering than the slopes of the Soufrière on the opposite side of the broad valley of the Wallibu Dry, and Trespé rivers to its north. The mass appears to be the remains of an avalanche, or succession of avalanches, of hot ash poured into the depression between the Soufrière and Morne Garu, on an enormously larger scale than anything formed by recent eruptions. It may be that the present bed of the Wallibu to the south and the broad valley to the north are enlarged and deeply excavated developments of the valleys that were formed at the sides of this prehistoric avalanche.

Descriptions of the changes in the fans and low plateaux subsequent to 1902, of the shore subsidence, and of the upper slopes of the mountain, are given in the full report, as well as a detailed description of the crater as seen in 1907.

The topography of the old crater is still correctly represented on the Admiralty Chart (published with the report, part i.). The whole of the interior of the crater is still quite bare, without any trace of returning vegetation; small patches of moss appear about the rim and on the slopes outside, then grasses, herbaceous plants, and large sheets of ferns, and lastly, below a height of about 1500 feet, luxuriant tropical vegetation. It is interesting that this sequence presents many points of resemblance with that observed on Krakatoa.

The present condition of the devastated areas is described fully in the report, which contains also a history of subsidiary eruptions which followed the great one of May, 1902. The difference in character between the eruptions of the Soufrière and Montagne Pelée, referred to in the report of 1902, appears to have continued since that year, the outbursts from the former volcano being generally less frequent but more violent than from the latter.

The report also contains an account of a subsequent visit to the volcano of Montagne Pelée, in Martinique, with a description of the crater as the author then found it; a discussion of the phenomena of the remarkable extrusion and subsequent destruction of the dome and spine, which have been described by Lacroix and others, and a comparison of the sequelæ of the great eruptions in the two islands of Martinique and St. Vincent.

Entomological Society, March 18.—Mr. C. O. Waterhouse, president, in the chair.—*Exhibits.*—Dr. T. A. Chapman: Photographs of the empty egg-shells and young larvæ of *Papilio homerus*.—G. C. Gahan: (1) A remarkable larva of the Tricentomidæ, which, though heteromerous, was wholly different in character to the larvæ of that group;

(2) a larva of *Dasillus cervinus* from Ireland.—**President**: Photograph drawing of the larvæ of Coniopteryx, a small neuropteran common enough in its perfect state, but rarely found as a larva, when it may be beaten out of fir trees.—**W. J. Kaye**: Three *Pereute* species from the Chanchamayo district of Peru, viz. *P. leucodrosine*, *P. callinice*, and *P. callianira*, together with specimens of the Nymphaline *Adelpha lara*. These Pierines and Nymphaline occurred together at an elevation of from 2500 feet to 3000 feet. It was wrong to suppose that any *Heliconius melpomene*-like species entered the association, as *Heliconius* species of this pattern did not ascend to such an elevation, or if they ever did it was only as a rare exception. On the under-side, if when both *Pereute* and *Adelpha* are at rest they conceal the coloured portion of the fore-wing, the hind-wing would then give a very strong similarity of one to the other.—**L. W. Newman**: A long and varied series of *Smerinthus populi* bred from wild Bexley parents in June, 1907, the series ranging from extreme dark specimens (about 6 per cent.) to very light (about 10 per cent.), and pink shaded or tinged (about 20 per cent.), the remainder being intermediate forms.—**Paper**.—The larvæ of *Tricentotoma cahanii*, Gray, and *Melittotomma insulare*, Fairmaire: **C. J. Gahan**.

Chemical Society, March 19.—**Sir William Ramsay**, K.C.B., F.R.S., president, in the chair.—A new form of pyknometer: **W. R. Boufield**.—The action of heat on α -hydroxycarboxylic acids, part iv., racemic- $\alpha\alpha'$ -dihydroxyadipic acid and meso- $\alpha\alpha'$ -dihydroxyadipic acid: **H. R. Le Sueur**. $\alpha\alpha'$ -Dihydroxyadipic acid, melting at 146° , has been resolved into its optical antipodes by fractional crystallisation of its cinchonidine salt. The acid melting at 174° , when heated, forms a lactone-lactide, and must be regarded as the meso- or internally compensated variety.—The spontaneous crystallisation of sodium sulphate solutions: **H. Hartley**, **B. M. Jones**, and **G. A. Hutchinson**. The authors have examined the spontaneous crystallisation of sodium sulphate solutions, and have found that if the solutions are subjected to mechanical friction three of the four possible solid phases, viz. ice, $\text{Na}_2\text{SO}_4 \cdot 7\text{H}_2\text{O}$, and Na_2SO_4 , are produced spontaneously at different temperatures. The spontaneous crystallisation of the fourth solid phase, $\text{Na}_2\text{SO}_4 \cdot 10\text{H}_2\text{O}$, is of rare occurrence.—Constitution of hydroxazo-compounds. Action of diazomethane and of mercuric acetate: **C. Smith** (and in part **A. D. Mitchell**).—*Orthobromophenols* and some bromonitrophenols: **P. W. Robertson**.—The constitution of thiocyanates containing an electronegative group: **A. E. Dixon** and **J. Taylor**.—The quantitative conversion of aromatic hydrazines into diazonium salts: **F. D. Chattaway**. All primary aromatic hydrazines can be quantitatively converted into the corresponding diazonium salts either by chlorine or by bromine. The operation can be most easily carried out by dissolving the hydrazine in glacial acetic acid, cooling the solution to about -15° by the addition of crushed ice, and either passing in a rapid stream of chlorine or adding the calculated quantity of bromine dissolved in acetic acid and similarly cooled by ice.—Quantitative separation of thallium from silver: **J. F. Spencer** and **Miss M. Le Pla**. A quantitative separation of the salts of silver and thallium is effected by a stream of chlorine, whereby the thallium is oxidised to the very soluble thallic chloride and the silver is precipitated as silver chloride. The thallium is eventually precipitated and weighed as thallos iodide.—Molecular volumes of the nitrites of silver, mercury, and the alkali metals: **P. C. Rây**.—Lithium nitrite and its decomposition by heat: **P. C. Rây**.—The existence in aqueous solutions of a univalent cadmium ion, a subvalent thallium ion, and a bivalent bismuth ion: **H. G. Denham**.—Note on the oxidation of phenylhydrazine by Caro's acid: **J. C. Cain**.—Some reactions of keten: **F. Chick** and **N. T. M. Wilmore**.—*Para-* and *meta-*nitrosocetanilide: **J. C. Cain**.—Labile isomerism among acyl-salicylamides and acyl-hydroxyamines: **A. W. Titherley**.

Royal Microscopical Society, March 18.—**Lord Avebury**, F.R.S., president, in the chair.—A series of fourteen mounted specimens of the rarer species of fresh-water polyzoa, mostly foreign species from Lake Tanganyika, Rhodesia, northern India, America, and Japan: **C. F.**

Rousselet.—Annual address: seeds, with special reference to British plants: the **President**. Attention was confined to the dicotyledons, the consideration of seeds of the conifers and monocotyledons being deferred until next year. The subject was treated from the point of view of the dispersal of the seeds and fruits by various agencies.

Royal Anthropological Institute, March 24.—**Prof. W. Ridgway**, president, in the chair.—Sinhalese magic: **Dr. W. L. Hildburgh**. The paper dealt with a variety of subjects, including charming ceremonies, astrology, and devil dancing. The charms were of various kinds, protective, for instance, to keep off evil spirits, or to guard the house, in which category amulets were included; love charms, charms to secure the favour of anyone, for example, a judge, and the like. A number of horoscopes were exhibited, which almost invariably take the form of a roll, as it is considered necessary to write each on a single leaf, which is best preserved in the roll form. The language in which horoscopes are written can only be read by the initiated, and consequently they are often translated, and the translations may be written in ordinary books without prejudicing the results. On the subject of devil dancing, **Dr. Hildburgh** exhibited a number of slides showing the different devils represented, and also a collection of the masks and costumes worn. Some of the devils represented are those who actually afflict the patient; others are powerful devils by whom the afflicting devils are controlled, while others again are devils who are afflicted as the patient is afflicted.

EDINBURGH.

Royal Society, March 16.—**Dr. R. H. Traquair**, F.R.S., vice-president, in the chair.—The lamellibranch fauna found in the Millstone Grit of Scotland, and the lamellibranchs from the Silurian rocks of Girvan: **Dr. Wheelton Hind**. The first of these important papers contained an account of the lamellibranchs found by the staff of the Geological Survey of Scotland in beds of the Millstone Grit series, between the Castlecary Limestone and the Coal-measures. The fauna is quite unique, containing, for example, the remarkable genus *Prothyris*, not hitherto recorded from British Carboniferous rocks. The specific form seems to be identical with that found in the Upper Coal-measures of Nebraska. Although a few members in the newly discovered fauna of the Scottish series have been found in the Millstone Grit of Hazel Hill, Yorkshire, and in beds immediately below the Coal-measures of Bristol and South Wales, yet the fauna as a whole bears a striking resemblance to the fauna of the American Coal-measures. The second paper dealt with the fine series of lamellibranchs collected by **Mrs. Robert Gray** from the district of Girvan. Many of the shells were in remarkable preservation, enabling the details of the hinge plate and interior to be examined. It was interesting to note such a fine development of lamellibranchs in these early rocks. A great proportion of the species are probably new, and many of the genera are described for the first time from British specimens. Here again the resemblance to certain American faunæ, especially those from the Trenton and Hudson groups of Minnesota and New York, is very striking.—A test for continuity: **Dr. W. H. Young**.—The theory of Hessians in the historical order of development: **Dr. Thomas Muir**.

PARIS.

Academy of Sciences, March 30.—**M. H. Becquerel** in the chair.—Various properties of the curves expressing either by their envelope, or directly, the coefficients of yield m of a thin-walled vertical weir, without lateral contraction, as a function of the relative pressure N' exercised under the sheets at the level of the sill: **J. Boussinesq**.—The determination of the time, both on land and at sea, with the aid of wireless telegraphy: **Bouquet de la Grye**. With the present installation at the Eiffel Tower, wireless signals can be sent a distance of 2000 kilometres, and it has been estimated that by increasing the electric energy this distance could be doubled. It is suggested that a special signal should be sent exactly at midnight, and it would have to be the subject of an international arrangement to avoid possible confusion by multiplication of such signals. Such a time signal would

be of the greatest service to navigators within its radius.

—On the proposal of the president, the examination of the proposition in the preceding note was referred to a committee composed of the members of the sections of astronomy, geography, navigation, and physics, together with MM. Darboux, Poincaré, and Cailliet.—The earthquake of March 26, 1908 (Chilapa, Mexico), registered at Paris: G. **Bigourdan**.—The manuscripts of Evariste Galois, catalogued by M. J. Jannery, and kept under this heading at the library of the Institute of France.—The relations between lecithin and tubercle bacilli and tuberculin: A. **Calmette**, L. **Massoli**, and M. **Breton**. Using the hemolytic action of snake poison in presence of lecithin as a test, the authors prove that the tubercle bacillus has an affinity for lecithin, and tuberculin behaves in a similar manner. The bearing of this on the reaction of tuberculin on the body is discussed.—The present state of the problem of the dispersion of light rays in interstellar spaces. A first attempt at the application to provisional determinations of stellar distances: Charles **Nordmann**. Discussing the recently published results of M. Tikhoff, the author points out that both their methods, although quite independent, lead to the same qualitative results, namely, that there is really produced a dispersion of light in interstellar space, and that it has the same sense as ordinary refractive media.—A phenomenon attributable to positive electrons in the spark spectrum of yttrium: Jean **Bequerel**. The experimental study of the Zeeman effect in the spark spectrum of yttrium gives results which may be most simply explained by assuming the presence of positive electrons.—The number of electrons in the atom: J. **Bosler**.—The determination of the factor of ionisation in solutions of hydrochloric acid: E. **Doumer**. A study of the ratio of the volumes of hydrogen and oxygen evolved during the electrolysis of solutions of hydrochloric acid of different concentrations with anodes of silver or mercury.—The density of the vapour of propionic acid: A. **Faucon**. By the method of Dumas the vapour density of propionic acid was found to vary from 3.27 at 123° C. to 2.57 at 210° C., the theoretical vapour density being 2.55. Two thermodynamical formulæ are applied to the results to calculate the heat of vaporisation of propionic acid.—The $\text{OH}(\text{I})\text{Cl}(\text{I})$: 4:6 trichlorophenol and its transformation into chloroquinone: E. **Léger**. The trichlorophenol is prepared by the action of a strong solution of sodium hypochlorite upon phenol; nitric acid (1.41) converts this into a mixture of trichloroquinone and tetrachloroquinone.—Styrolene oxide: MM. **Tiffeneau** and **Fourneau**.—The β -*aa*-dialkyl-ketone alcohols: E. E. **Blaise** and I. **Herman**.—The magmatic parameters of the series from the volcano Monte Ferru, Sardinia: M. **Deprat**.—Researches on the development of *Glossosporium nervisequum*: A. **Guilliermond**.—The Lagoa Santa race in the precolombian populations of the equator: M. **Rivet**.—The American Synalpheæ: M. **Coutière**.—The tectonic of the littoral of the Algero-Moroccan frontier: Louis **Gentil**.

DIARY OF SOCIETIES.

THURSDAY, APRIL 9.

ROYAL INSTITUTION, at 3.—The Animals of South America: R. Lydekker, F.R.S.

INSTITUTION OF ELECTRICAL ENGINEERS, at 8.—Electric Supply Prospects and Charges as affected by Metallic Filament Lamps and Electric Heating: H. W. Handcock and A. H. Dykes.

INSTITUTION OF MINING AND METALLURGY, at 8.—The Electrical Equipment of Gold Mines: H. J. S. Heather.—Addendum to Paper on Earth Temperatures on Witwatersrand Gold Fields: H. F. Marriott.—The Corat Weight: E. J. Vallentyne.—An Electrometer for Testing the Suitability of an Ore for Magnetic Separation: L. H. L. Huddart.—The Gold Alluvials of the River Drac in Hungary: A. von Gernet.

FRIDAY, APRIL 10.

ROYAL INSTITUTION, at 9.—The Carriers of Positive Electricity: Prof. J. J. Thomson, F.R.S.

ROYAL ASTRONOMICAL SOCIETY, at 5.—Measures of Southern Double Stars 1907: J. L. Scott.—Tables of the Hypergeometrical Functions

$F\left(\frac{1}{2}, \frac{5}{6}, 2, \sin^2 \frac{\phi}{2}\right)$, and $F\left(-\frac{1}{6}, \frac{7}{6}, 2, \sin^2 \frac{\phi}{2}\right)$ between the Limits ϕ to equal 60 and 120 Degrees: C. J. Merfield.—On Dr. Roberts's Method of determining the Absolute Dimensions of an Algol Variable Star: Rev. J. J. O'Connell.

On the Orbit of 2023 Secchi = 2243 BC: 853 AB; and γ Velorum (and γ): T. J. See.—Note on the Adopted Coordinates of the 1-megawatt (Columbia) Observatory: A. M. W. Downing.—Probable Paper 2: Description of a Long focus Celeostat Reflector: J. H. Reynolds.—Note

on the newly-discovered Eighth Satellite of Jupiter: Royal Observatory, Greenwich.

PHYSICAL SOCIETY, at 8.—An Experimental Investigation of the Nature of γ Rays: Prof. W. H. Bragg, F.R.S., and Mr. Madsen.—Experiments on Artificial Fulgurites: Miss D. D. Butcher.—Short-spark Phenomena: W. Duddell, F.R.S.

INSTITUTION OF MECHANICAL ENGINEERS, at 8.—The Governing and the Regularity of Gas Engines: J. Atkinson.—The Effect of Mixture Strength and Scavenging upon Thermal Efficiency: Prof. B. Hopkinson.

SATURDAY, APRIL 11.

ROYAL INSTITUTION, at 3.—Electric Discharges through Gases: Prof. J. J. Thomson, F.R.S.

MONDAY, APRIL 13.

ROYAL GEOGRAPHICAL SOCIETY, at 8.32.—Explorations on and Around Prince Charles Foreland, Spitsbergen: Dr. W. S. Bruce.

TUESDAY, APRIL 14.

ROYAL STATISTICAL SOCIETY, at 5.

INSTITUTION OF CIVIL ENGINEERS, at 8.—Further Discussion: The King Edward VII. Bridge, Newcastle-on-Tyne: F. W. Davis and C. R. S. Kirkpatrick.

WEDNESDAY, APRIL 15.

GEOLOGICAL SOCIETY, at 8.—The Geological Structure of the St. David's Area (Pembrokeshire): J. F. N. Green.—Notes on the Geology of Burma: L. V. Dalton.

ROYAL METEOROLOGICAL SOCIETY, at 7.30.—Report on the Phenological Observations for 1907: E. Mawley.—The Anticyclonic Belt of the Southern Hemisphere: Colmel H. E. Rawson, C.B.

ROYAL MICROSCOPICAL SOCIETY, at 8.—On Dendritic Growths of Copper Oxide in Paper: J. Strachan.—Nature's Protection of Insect Life: F. Enock.

VICTORIA INSTITUTE, at 3.30.—The Assuan and Elephantine Papyri: Dr. L. Belleli.

CONTENTS.

	PAGE
Experimental Embryology. By J. A. T.	529
Geological Revivalism. By Prof. Grenville A. J. Cole	529
Hydraulics	530
Technical Chemical Analysis. By W. A. B.	531
British Archaeologists in Italy. By H. H.	532
Our Book Shelf:—	
Hobart and Ellis: "Armature Construction"	532
Yerkes: "The Dancing Mouse; a Study in Animal Behaviour."—W. B.	533
Hoernle: "Studies in the Medicine of Ancient India"	533
Kelman: "The Sea-shore, Shown to the Children"—Frank Balfour Browne	533
Engel: "Déviations des Compas"	534
"Bulletin of Miscellaneous Information. Royal Botanic Gardens, Kew"	534
Lloyd: "The Will to Doubt: an Essay in Philosophy for the General Thinker"	534
Letters to the Editor:—	
An Annotated Copy of Newton's "Principia."—W. R. B. Prideaux	534
Proposed Alteration in the Calendar.—Dr. D. Mackie	534
Helium in the Atmosphere.—Dr. J. W. Evans	535
April Meteors.—John R. Henry	535
Coloration of Glass and Quartz by Radium.—Charles E. S. Phillips	535
An Early Notice of Neolithic Implements.—Prof. John L. Myres	535
Notes on Ancient British Monuments. VIII. The Aberdeen Circles (continued). (Illustrated.) By Sir Norman Lockyer, K.C.B., F.R.S.	536
Trees. (Illustrated.) By A. W. B.	538
Dr. James Bell, C.B., F.R.S. By T. E. T.	539
Notes	540
Our Astronomical Column:—	
Comet 1907d	544
Observatory Map of the Moon	544
The Recent Maximum of Mira Ceti	544
Sun-spot Observations	544
Meridian Circle Observations of Parallax Stars	544
The Recent Total Solar Eclipse	544
A New Expedition to the Southern Hemisphere	544
The Hamburg Observatory	544
The Ziegler Polar Expedition (Illustrated.) By Dr. C. Chree, F.R.S.	544
Sanatoria for Consumption. By Dr. R. Fielding-Ould The Society of Dyers and Colourists	546
Encke's Comet	547
University and Educational Intelligence	548
So. letters and Academies.	549
Diary of Societies	552

THURSDAY, APRIL 16, 1908.

THE CHEMISTRY OF THE HIGHER FUNGI.

Chemie der höheren Pilze, eine Monographie. By Dr. Julius Zellner. Pp. vi+257. (Leipzig: W. Engelmann, 1907.) Price 9 marks.

THE detection, isolation, and characterisation of the definite compounds resulting from the vital processes of living organisms is a branch of organic chemistry which is slowly developing and of which the progress is necessarily dependent upon the development of pure chemistry. In fact, it may be said that in some respects this department of biochemistry is in advance of the pure science, because the living organism has already furnished chemists with immense numbers of compounds which are quite definite, but of which the chemical constitution is at present unknown. Indeed, it may be stated in much wider terms that there is probably no such thing as an "indefinite" chemical compound in the whole animal or vegetable world. There is no doubt that many, perhaps the majority, of the organic compounds present in animals or plants are of very high molecular weights and of great atomic complexity, and there is also no doubt that many of the products which have been isolated and studied are complex mixtures or combinations of such complexes. But to speak of such products as "indefinite" is simply tantamount to the admission that our modern methods of research are inadequate, and that our knowledge of biochemistry must develop concurrently with the development of new methods for dealing with these highly complex molecules.

The ultimate aim and object of scientific chemical work in this field is presumably to follow the development of the various compounds in the living organism—to detect the genetic relationships between the molecules for the purpose of learning how nature works in the vital laboratory. As a prelude to this knowledge it is necessary to get, in the first place, an inventory, as complete as possible, of the compounds actually known to exist in, or to be produced by, the animal or plant. With respect to plant chemistry it may be said that practically all the works dealing with this subject have hitherto been of the nature of such catalogues or inventories. Here and there, as the result of these studies, genetic relationships have been detected, but this field of research is urgently in need of systematic cultivation. As a subject it bristles with practical difficulties, and for the achievement of successful results the investigator should combine the qualifications of an expert chemist with those of the expert botanist. It is not surprising that, in the circumstances, the biostatistical aspect of plant chemistry should have progressed so much more rapidly than the biodynamical aspect.

Dr. Zellner's monograph may be regarded as another contribution to plant chemistry from the biostatistical side. It deals with a particularly interesting

group, and will be found invaluable to students and workers in this field. By the "higher fungi" the author means all those orders generally classed as fungi with the exclusion of bacteria, moulds, and yeasts. The line of demarcation, as Dr. Zellner points out, is perhaps not, strictly speaking, a scientific one, but for practical purposes it is both justifiable and convenient, as bacteriology and fermentation have been developed into large and important branches of science, and their literature is amply provided for.

In treatment the present work follows the chemical rather than the botanical classification, the chapters, of which there are twenty-two, bearing the titles of the chemical families, beginning with the mineral constituents, and passing on to the hydrocarbons, fats, lecithins, alcohols, acids, amino-acids, purine group, bases, carbohydrates, tanning and colouring matters, resins and terpenes, proteins, &c. The chapters on the ferments and toxins of fungi will be of particular interest to many readers. One chapter is devoted to the consideration of the nutritive value of fungi, which the author does not consider to be very high. In this chapter there are many valuable tables giving the quantitative results of the analysis of the proximate constituents of large numbers of species. In the case of certain chemical families of very wide occurrence, such as the carbohydrates, the author has been obliged to interpolate tables based on the botanical classification. Thus in chapter xii. there is a tabulated list of no fewer than 233 species, giving the distribution of mannitol, mycose (trehalose) and glucose, or other reducing sugar, together with the name of the observer and the year of the discovery of the carbohydrates. In giving the details of the various compounds, the author has wisely thought it unnecessary to enlarge upon the chemistry of well-known and widely distributed substances which are of general occurrence in the vegetable kingdom. On the other hand, compounds of special interest in mycological chemistry, such, for example, as muscarin, ergotin, choline, &c., which are essentially, if not exclusively, products of fungi, are dealt with exhaustively. As is so generally the case with German writers of monographs on scientific subjects, the references to authorities are fully given.

As a contribution to scientific literature there is nothing in this work calling for criticism. The author, unlike many specialists, takes a remarkably fair view of the "perspective" of his subject, and the result is a work which may be described as concisely complete. It may savour of impertinence for a "foreigner" to complain of the spelling of his own language by a German writer, but those who are in the habit of following German work in our own subjects—i.e. the working men of science of this country generally—have become accustomed to certain established modes of spelling in such scientific publications as the *Berichte* of the German Chemical and Botanical Societies, and so forth. We in this country have become "hardened" (literally) into seeing K for C (hard); we have got over the first shock of seeing such words as Glukose, Fruktose, Mykose, &c., and

we have even been obliged to admit that Muskarin is obtained from *Amanita muscaria*.¹ But now Dr. Zellner has a further shock for us, and we find such words as *Kalzium*, *Zitronensäure*, *Glycerin*, *Acetyl*, &c., scattered throughout his pages. Thus (p. 97) Mykose forms an "Oktoazetylverbindung," which is no doubt chemically true, but, stated in this form, it seems to jar upon the orthographic nerve of the average English reader. All this is, of course, purely personal, perhaps old-fashioned or narrowly insular, and has nothing to do with the scientific merits of the work, which, as has already been said, are of a very high order, and every worker in the domain of plant chemistry will be grateful to the author for having produced it.

R. MELDOLA.

BOTANICAL INSTRUCTION.

- Plant Biology. A Text-book of Elementary Botany arranged for Modern Methods of Teaching.* By Dr. F. Cavers. Pp. xvi+460. (Cambridge: University Tutorial Press, 1907.) Price 3s. 6d.
- Laboratory and Field Manual of Botany.* By J. Y. Bergen and B. M. Davis. Pp. viii+257. (Boston and London: Ginn and Co., n.d.) Price 4s. 6d.
- Studies in Plant Life.* By J. Adams. Pp. v+179. (Dublin and Belfast: Fallon and Co., Ltd., n.d.)
- Elementary Botany.* By M. A. Liversidge. Pp. 128. (London: Blackie and Son, Ltd., 1907.) Price 1s. 6d. net.
- Introduction to Elementary Botany.* By Charlotte L. Laurie. Pp. viii+84. (London: Allman and Son, Ltd., n.d.) Price 1s. net.
- Our Woodlands, Heaths and Hedges.* By W. S. Coleman. Pp. viii+141; with 8 plates. New edition, entirely reset. (London: George Routledge and Sons, Ltd., 1907.) Price 1s.

THE advocates of an exclusively experimental course of study in the natural sciences are confronted with the difficulty of time limitations, so that in practice it becomes necessary to strike a balance between lecture and practical work. Dr. Cavers has indicated in "Plant Biology" the lines of work that he has found successful with training-college students, in which the training is almost entirely derived from observation and experiment. The foundation of the course consists of experiments—of which about three hundred and fifty are outlined—in connection with the nature and function of parts of the flowering plant; so far as possible the bean plant is used as the type. Flower and soil, biology and ecology provide a subsidiary section. The course differs mainly from ordinary practice in excluding the examination of selected types from the main groups and in the general omission of flowerless plants. With regard to the composition of the subject-matter, the author deserves great commendation; the arrangement is well planned, the experiments are generally simple and practicable, and the information is contrived to make the student

think. A series of questions at the end of each chapter can be used either by the student or his instructor to gauge the progress that is being made. The appendices also contain much useful matter; hints on practical work refer to special opportunities afforded month by month; a summary of Engler's system of classification is provided, and a glossary of botanical terms.

The manual prepared by Mr. Bergen and Dr. Davis is a practical handbook primarily arranged in accordance with their text-book "Principles of Botany." The first part relates to the structure and physiology of seed plants. The plan adopted of outlining the instructions without detailed information that is left for the student himself to discover is good, but the authors have not been very happy in distinguishing between more and less important facts or in systematising the subject-matter. As an instance, it may be cited that the description of a typical young dicotyledonous stem is not particularly noted, while the structure of the climbing dicotyledonous stem receives undue prominence. The second part, indicating type studies of flowering and flowerless plants, is more felicitous. Spirogyra forms a suitable introduction for studying the cell in detail. Pleurococcus, Vaucheria, Ulothrix, and CEdogonium are chosen as the types of green algae, while reference is also made to Ulva, Cladophora, and Coleochaete. Microsphaera, the lilac-mildew, is selected as the type of an Ascomycete, and the introduction of Mursilia is quite a desirable innovation. Ecology is dealt with in the third section under the headings of flower pollination, seed dissemination, types of vegetation, &c. The remainder of the book is devoted to accessory but valuable hints on reagents, methods of fixing and staining, cultures of the lower plants, and apparatus. Considered as a whole, the authors have provided a useful manual that presents a large amount of practical information in a limited amount of space.

The small book written by Mr. Adams is of an extremely superficial nature. Owing to generous spacing and a large number of illustrations, the text is less than would be expected. In the circumstances, it would have been advisable to give more space to the essentials of plant structure as exemplified in the flowering plant and to have omitted the cursory descriptions of flowerless plants and plant habits. The author has taken pains to introduce facts of practical importance to the agriculturist, such as fertilisers, dwarf shoots, &c., but there is a lack of clearness and accuracy in some of the elementary definitions.

The limits of Miss Liversidge's book are set by the intention of covering the syllabus of work for the Oxford and Cambridge junior local examinations. It is evident that it has also been written rather with the view of giving facts for examination purposes than of training the young mind. There are four parts, assigned to external morphology, anatomy, physiology, and systematic botany. The design of the physiological part is good, but the experimental

¹ The familiar *Chemisches Central-Blatt* has now become a *Zentral-Blatt*.

instructions could be materially improved. The anatomical facts are clearly stated considering that this part of the subject is much more advanced than the rest of the book. But speaking generally, the author has aimed at brevity, and in so doing has sacrificed exactness; this is specially noticeable in the course of external morphology, where several mistakes and incomplete definitions occur.

The short introduction to elementary botany planned by Miss Laurie is a direct antithesis to the last, as the facts recorded are few, but they are deduced or suggested so as to arouse interest and stimulate experiment and thought. Written primarily for quite small children, it shows how facts in the life-history of plants may be taught from simple experiments, such as the growth of mustard seeds in a bottle. In addition to morphology and the accompanying physiology, there are chapters on interrelation between plants and animals, climbing plants and colours of plants. Although the information is couched in a form understandable by young children, the book could be advantageously adopted as a first course for older children, and might be profitably consulted by many teachers as a guide to imparting instruction.

The observation of trees and shrubs is preeminently suited for a nature-study class, and possesses the advantage that there is much to be noted even during the winter months. A short, concise manual or primer at a modest price is an existing desideratum. The volume written by Mr. Coleman compasses the subject and certainly sells at a modest price, but it fails to satisfy the want alluded to. The author has culled much interesting information of a general and historic nature, but there is an almost entire absence of the numerous botanical features of interest, such as winter buds, arrangement of leaves, &c., and for identification the reader is mainly dependent upon the illustrations. The notes on animals and insects haunting the various trees and shrubs are so useful that one wishes the author had given more space to these facts of natural history. A list of British lepidopterous insects the caterpillars of which feed on certain plants is provided in an appendix.

APPLIED MATHEMATICS.

- (1) *Computation and Mensuration*. By P. A. Lambert. Pp. ix+92. (New York: The Macmillan Co.; London: Macmillan and Co., Ltd., 1907.) Price 3s. 6d. net.
 - (2) *A First Statics*. By C. S. Jackson and R. M. Milne. Pp. viii+380. (London: J. M. Dent and Co., 1907.) Price 4s. net.
 - (3) *Practical Calculations for Engineers*. By C. E. Larard and H. A. Golding. Pp. xiii+455. (London: C. Griffin and Co., Ltd., 1907.) Price 6s. net.
- (1) THE author says that the boys in the secondary schools of America are not taught to apply their mathematics independently, and consequently find, on entering college, that they have difficulty in

making effective use of their theoretical knowledge, and this book is intended as a link between the school and college courses, to be studied either at the end of one or the beginning of the other.

The same deficiency is manifest in boys leaving our schools, and in this country is being met by improved teaching combined with practical work in the laboratory, as a regular part of the school course.

The book is admirably planned and written, is concise, neat in method and interesting, and meets a real want in a worthy manner. It begins with examples of direct measurement, approximate numbers, and contracted arithmetic, estimating the degree of accuracy by the number of decimal places; perhaps the number of significant figures would have been better. This is succeeded by examples of practical geometry, including the construction and measurement of triangles, and some squared-paper work. Then follows the volume of a prismatoid, and in later chapters on mensuration it is shown that the prismoidal formula, or Simpson's rule, is widely applicable. There is a useful chapter on trigonometrical computation, introducing very appropriately the notion of a vector with examples of vector summation. Logarithms and the slide rules are next considered, followed by an interesting chapter on limits, illustrated by several important convergent series. The author always seizes on the salient points, is never prolix, and the interest never flags; in each chapter the student is well started on his way, then provided with good and suggestive examples, and wisely left to his own resources. Thus, although the pages of the book are comparatively few, the usual ground is covered, and a thorough and efficient training in practical computation is provided. English teachers would do well to consult this work.

(2) This text-book proceeds on easy lines, and the student is provided with a wealth of examples at every stage from which to choose, the answers being collected at the end of the volume. In their scheme the authors have considered "the historical order of development of the subject, as indicating almost infallibly the line of least resistance." Thus in the first chapter the principle of the lever is introduced, and the law of moments for parallel forces is established by simple experiments, then illustrated by examples of ancient and modern steelyards and balances, and finally applied to find the conditions of equilibrium of three parallel forces in a plane. The next two chapters deal with the parallelogram law for forces at a point, the treatment being here again, as always, experimental, graphical, and analytical, with examples of useful applications in the arts. It is not quite clear why the authors should substitute the term "geometric" addition for *vector* addition, or why arrow-heads should "sometimes" instead of *always* be inserted in vector diagrams. In chapter iv. the principle of moments is again considered, being now deduced from that of the parallelogram and applied to couples. Then follow sections dealing with machines, friction, and centres of

gravity, the latter being somewhat extensively applied, including Galileus's rules and mensuration problems. The concluding chapters relate to forces and jointed frames in two and three dimensions, with examples of roof and bridge trusses and cranes.

The general plan of the book is good, the endeavour being to "lay stress on the practical utility of the science" rather than on "rigour of deduction." In carrying out this very laudable idea, the authors, through lack of practical experience, sometimes err by giving drawings like that of the safety-valve on p. 242, in which the constructional details are almost offensively crude, or by giving examples like No. 16, p. 140, where the efficiency of a Weston differential pulley-block is stated to be 80 per cent., or like No. 38, p. 77, in which a rail, supported at the ends and loaded as a beam at the middle, is said to be bent into a circular arc. In spite of these minor defects, however, the book can be recommended as affording an excellent introduction to statics.

(3) The general character of this work places it somewhere between the engineering pocket-book and the college text-book. The methods, formulae, and appliances which a student encounters during a good college course in mechanical engineering are here, not demonstrated, but collected and described, systematically, and applied to such practical examples as are likely to occur in an engineering workshop. In section i. the subject-matter comprises arithmetical, graphical, and mechanical computations, by modern abbreviated methods, and includes technical mensuration, the use of the slide-rule and the planimeter, and mathematical tables. In section ii. we have laboratory experiments and calculations relating to machines, acceleration, momentum, force, work, energy, and power. Section iii. relates to boilers and heat engines, considered both from the thermodynamical and constructional point of view, with a chapter on the cost of motive power. These three sections are well adapted for students who have passed from college to practical work, in helping them to recall their theoretical knowledge as occasion may require. A good collection of examples will be found for practice. The style is perhaps somewhat diffuse, and there are a few minor defects, but this portion of the book will be appreciated in many quarters.

The fourth and concluding section, however, is of most interest and value. It deals with the business side of engineering, a branch that is beyond the usual college course, yet of paramount importance to the young aspiring engineer. The subjects discussed are the commercial aspects of engineering; the qualifications and duties of the works manager; the calculation of weights and the preparation of estimates and bills of costs; and the bonus and premium systems of wages. The authors give some most striking examples of the great value of squared-paper work in the systematic plotting of variable quantities in all branches of a manufacturing establishment, and the results to be learnt therefrom. This section is extremely suggestive, and will well repay the careful study of all practical engineers.

MULTUM IN PARVO.

- (1) *Die Tierwelt des Mikroskops (die Urtiere)*. By Dr. Richard Goldschmidt. Pp. iv+100; 39 figures. (Leipzig: B. G. Teubner, 1907.) Price 1.25 marks.
- (2) *Das Süßwasser-Plankton*. By Dr. Otto Zacharias. Pp. iv+130; 49 figures. (Leipzig: B. G. Teubner, 1907.) Price 1.25 marks.
- (3) *Befruchtung und Vererbung im Pflanzenreiche*. By Prof. K. Giesenhagen. Pp. iv+132; 31 figures. (Leipzig: Quelle and Meyer, 1907.) Price 1.25 marks.
- (4) *Das Werden und Vergehen der Pflanzen*. By Prof. P. Gisevius. Pp. 132; 24 figures. (Leipzig: B. G. Teubner, 1907.) Price 1.25 marks.
- (5) *Das Scharotzertum im Tierreich und seine Bedeutung für die Artbildung*. By Prof. Ludwig von Graff. Pp. iv+132; 24 figures. (Leipzig: Quelle and Meyer, 1907.) Price 1.25 marks.
- (6) *Die Mechanik des Geisteslebens*. By Prof. Max Verworn. Pp. iv+104; 11 figures. (Leipzig: B. G. Teubner, 1907.) Price 1.25 marks.

IT was Leibniz who said that the more science advances the more it will be expressed in little books. If that is so, the recent abundant crop of primers may be regarded as a healthy sign—especially when we find that many of them are very good. It need hardly be said that an introduction to the study of parasitism by von Graff, or to the study of fresh-water plankton by Zacharias, cannot fail to be useful and stimulating. There is also an economic side to the phenomenon presented by the bundle of primers before us. It seems as if the great encyclopædias, which were relatively costly, were being replaced by these cheap booklets. Instead of saving up to purchase the huge volume P, containing much that he does not want, the student can buy at a shilling each three little treatises on parasitism, plankton, and protozoa. This expresses a democratisation of scientific literature, with its familiar analogue in the popular "sixpennies."

(1) In a clear and precise way, Dr. Richard Goldschmidt tells the story of the Protozoa—how they came to be known, where they are found, how they live, what part many of them play in the economy of the sea, what they have done in building up chalk cliffs and the like, and how they come into close quarters with man in malaria and sleeping sickness, and other diseases. With the aid of excellent figures, most of which are familiar, and some of which, like Max Schulze's *Polystomella*, could hardly be improved upon, the author introduces the student to the rhizopods, the infusorians and Sporozoa, and although the book will not, of course, enable the observer to identify many of the Protozoa which he may discover, it will help him to understand them and to realise how many problems even the common *amœba* still raises in a reflective mind.

(2) The indefatigable director of the biological station at Plön deals with a subject to the study of which a great part of his life has been honourably devoted—the fresh-water plankton. His treatment of

it seems to us to be peculiarly successful, as we would expect from one writing out of full knowledge and with strong enthusiasm, and what he has to say may be profitably read by many besides the laity. Besides descriptions of the various constituents of the plankton—crustaceans, rotifers, infusorians, algæ, and so on—Dr. Zacharias gives an account of methods of study, of the relations of the plankton to environmental conditions, of the origin of new species and varieties by isolation, of the inter-relations of plants and animals, of the application of hydrobiology to fisheries, and of the pioneer station at Plön.

(3) Prof. K. Giesenhagen deals with a subject more difficult than those of the two preceding volumes—namely, fertilisation and heredity in the vegetable kingdom. He begins with the phenomena in their simplest terms in the green algæ, and works gradually upwards through moss and fern to phanerogams, not forgetting the by-paths of parthenogenesis and vegetative multiplication. The point about his treatment is that he uses the facts as a basis for a discussion of the deep problems of heredity, such as those raised and in part solved by the discoveries of Mendel and his successors.

(4) Prof. Paul Gisevius has compressed into a small volume what every educated person should know about plants, and there is a flavour of intellectual "pémican" in the result. He deals first with the structure of plants, both inside and outside; he then discusses nutrition and respiration, constructive metabolism, and the migration of material; he leads us from seed and seedling to the flowering, fruiting and withering; he takes a survey of the vegetable kingdom, and throws the light of the past on the present; and he ends up with the phenomena of reproduction and with breeding experiments. It seems to us that he attempts too much, carrying terseness to an extreme, but his work is well done.

(5) Prof. Ludwig von Graff supplies a masterly introduction to the study of parasitism among animals. Without overwhelming us with details, he takes us into the heart of the subject, and the style of the book is a model. Von Graff has much that is extremely interesting to relate—for parasitology has made great advances of recent years—and his discussion of such themes as the origin of the parasitic habit and the influence of parasitism on the parasite is very instructive. Admirable too are the tabular summaries of life-histories. The appalling list of human parasites, based on Braun's well-known treatise, reaches a total of 129, and this number must be greatly increased, since in not a few cases several species are counted as one.

(6) In some ways the most striking volume in this bundle of primers is that in which Prof. Max Verworm deals with "the mechanism of psychical life." It consists of five lectures on the physiological aspects of mental processes, and the author has been well advised to leave them with the vividness of oral discourse. He deals with the relations of mind and body (the dualism of which he regards as a superannuated fiction), with the processes, e.g. fatigue-changes, in the nervous elements, with the dissimulatory stimuli that

pass incessantly through the intricate maze of nerve-fibres and ganglion-cells, with the fascinating phenomena of sleep and dreaming, and with the puzzles of suggestion and hypnosis. More, perhaps, than in regard to the other little books which we have noticed is there room here for difference of opinion, but all will agree that the author presents his view of psychical life with masterly clearness. It must be clearly noted that he refrains from giving his facts any philosophical setting, he argues neither for materialistic nor for spiritualistic interpretation, he aims at a physiological analysis of the sequences with which we are all familiar, and he does not conceal that his title expresses a scientific ideal rather than an actual achievement.

J. A. T.

OUR BOOK SHELF.

Index of Archaeological Papers (1665-1890). Edited by G. L. Gomme. Pp. xi+910. (London: A. Constable and Co., Ltd., 1907.) Price 25s. net.

THIS volume is in effect an author-index to the papers of archaeological and kindred character published in the journals of learned societies and elsewhere during the twenty-five years prior to 1891. It includes the contents of some ninety-four periodicals, amounting in all to nearly 20,000 monographs under the authors' names. An appendix supplies a list of the titles which were found to have been omitted from the main classification during its compilation.

The papers of like characters which have appeared from 1891 until the last year or so have already been similarly treated in the annual index, published under the auspices of the Congress of Archaeological Societies in union with the Society of Antiquaries. There is thus placed before the student of to-day, as the editor justly claims, a continuous index from the first publications in the *Philosophical Transactions* of the Royal Society down to the present time. This work is henceforth as indispensable to the student of British archæology, in particular, as are the tables of logarithms, sines, and cosines to the mathematician. The latter may be calculated, indeed, just as the archaeological papers may be hunted out by individual workers; but those who in the past have wasted hours and days in turning over the pages of twenty-five times ninety-four volumes in search of their own quest will be grateful to Mr. Gomme and his helpers for their patient work, and for the completeness of the result.

This index includes within its scope, not only the archæology of the British Isles, but archaeological fragments from many countries. Thus we find Evans (A. J.) on Albania, Birch, Budge, Petrie, Poole (R. S.), and Renouf on the problems of Egypt, Hogarth on inscriptions from Salonic, Ramsay on the results of his explorations in Phrygia and western Asia Minor, and so forth. The difficulty of editing such a mass of different material must have been very great, and the work laborious. Here and there we notice the inclusion, whether accidental or intentional, of papers which seem to us to be irrelevant; as, for example, "The Writings and Influence of Coleridge" (Redish), "The Height and Weight of Boys aged Fourteen in Town and Country Schools," and other more or less statistical writings, by Francis Galton. In other cases where folklore is the subject, discrimination is less easy; and we certainly think that the editor has been wise to incorporate writings of philological character in cases where the author's material was archæological. Thus M. Maspero on various

features of Egyptian archaeology and philology, and Sir J. Rhys covering similar ground in Wales, are not inappropriate.

There is one thing, however, which we commend earnestly to the Congress, namely, the preparation and publication of a supplementary place-index, which might be brought as nearly to date as possible, and would render this volume and the annual indexes doubly or trebly valuable. The fact that some fifty-four of the journals indexed are the publications of local archaeological societies speaks for itself. With Mr. Gomme's work completed the rest would be easy; but it is none the less an urgent need.

Notions générales de Biologie et de Plasmogénie comparées. By Prof. A. L. Herrera. Translated by G. Renaudet. Pp. xxviii+260. (Berlin: W. Junk, 1906.) Price 10 marks.

THIS is a remarkable book, full of suggestive speculation, much of which is unlikely to command general acceptance, but at the same time the analogies which the author draws between emulsions of various sorts and organic form are full of interest.

The whole book seems to have arisen out of a series of notes for students, and its rather disconnected form retains the impress of this original design. The result is rather original, and arrests the attention even where one does not agree with the author.

Prof. Herrera suggests that organic structure arises as the result of precipitation, coagulation, or solidification modified by the presence of diffusion currents and similar influences. A large number of experiments are given in which commonly occurring organic structure is closely imitated by precipitations of silica, &c., under conditions which are carefully described.

There is a refreshing freedom from dogmatism, but the author has the full courage of his own convictions, as is shown by the crisp and clear definitions which he gives of phases of organic life that most investigators find difficult of satisfactory expression.

The work is introduced by a preface from the pen of Moritz Benedikt, professor of medicine at Vienna, who is, of course, in sympathy with the general trend of the book, whilst he is, like its author, alive to the many difficulties in establishing all the conclusions. A sentence from the final essay of the volume, also contributed by Prof. Benedikt, puts the main thesis of Herrera so clearly that we may be pardoned for quoting it:—"... le monde organique, et la vie, sont nées du monde minérale dans les masses de vésicules mousseuses hautement organisées."

Einführung in die Paläontologie. By Gustav Steinmann. Second edition. Pp. xii+542; illustrated. (Leipzig: W. Engelmann, 1907.) Price 14 marks.

IN the matter of bulk this edition shows a marked increase over the first edition (1903); while, in most cases, at any rate, it appears to have been brought fairly well up to date. The ancestral proboscideans from the Egyptian Eocene are, for instance, duly noticed, and recent work on Patagonian Tertiary vertebrates likewise receives due attention. On the other hand, we notice an absence of any reference to Dr. Broom's opinion that the South African Triassic *Tritylodon* is, after all, a mammal; while in certain cases the author departs from the generally accepted classification without any apparent or sufficient reason. In the ungulate mammals, for example, the hippopotamus is removed from the *Artiodactyla* to find a place with *Dinoceras* and *Coryphodon* among the *Amblypoda*; in fact, *Hippopotamus* and the American Tertiary genus *Merycochærus* are actually included in the family *Coryphodontidae*. This is bad enough, but when we find *Oreodon*—the immediate ally of *Mery-*

cochærus—occupying its proper position in the neighbourhood of the camels, we are at a loss whether to attribute such eccentricities to mere carelessness or to lack of knowledge on the part of the author.

Carelessness cannot, however, be pleaded in the case of the phylogeny of the vertebrata given at the close of the volume. For there we have carefully compiled tables in which the dolphins are brigaded with ichthyosaurs as *Ichthyotheria*, while sperm-whales and plesiosaurs are grouped together as *Plesiotheria*, and whalebone whales and the mosasaurs as *Thalattotheria*. The giving of definite names to these incongruous groups is of itself a sufficient proof that the author regards them as definite phylogenetic assemblages, and not mere instances of adaptive analogy; but the matter is clinched by the following statement on p. 512, viz.:—"Wir sind also vor die Entscheidung gestellt, entweder ein unverständliches und geradezu übernatürliches Eingreifen voraussetzen, oder uns im Rahmen des gesetzmässigen Naturgeschehens die zahlreichen einzelnen Säugerstämme voneinander gesondert aus ebensoviele Stämmen der Reptilien hervorgegangen zu denken."

With such eccentricities, alike in classification and phylogeny, we are unable to recommend Dr. Steinmann's volume as a trustworthy guide to the student of palæontology. Neither can we congratulate the publishers on the illustrations, unless, indeed, a "palæographic" style of art be deemed specially suitable to a palæontological treatise. R. L.

The Chemistry of the Diazo-compounds. By Dr. J. C. Cain. Pp. xi+172. (London: Edward Arnold, 1908.) Price 10s. 6d. net.

WHEN we compare the steady output of monographs on chemical subjects on the Continent with the few publications of this class in English, we naturally ask whether English publishers are less enterprising than their neighbours, or English chemists less given to specialisation.

We are inclined to the former view, and regard it as a welcome sign that the new departure in English chemical literature, introduced in the form of physical chemistry manuals, and published under the editorship of Sir W. Ramsay, has found favour with another enterprising firm, and extended to organic chemistry. It is to be hoped that the present volume represents the first of a series of similar publications.

Although the chemistry of the diazo-compounds appears at first sight to be a subject of rather restricted range, it must not be forgotten that it is of direct technical importance, connected as it is with one of the largest branches of the colour industry. Moreover, a special interest attaches to the appearance of Dr. Cain's book at the present time, for it stands as a memorial of the fiftieth anniversary of Griess's famous discovery. Although Johann Peter Griess was a German, born and bred, the bulk of his researches on the diazo-compounds were carried on in this country, first whilst he was acting as assistant to Hofmann in London, and later during intervals of leisure extending over many years after his appointment as chemist to Messrs. Allsopp, brewers, of Burton-on-Trent.

The protean character of the chemical changes which the diazo-compounds exhibit, their close connection with colour chemistry, as well as their structural relations, which still furnish a perennial subject of discussion, appeal in turn to the scientific and industrial chemist (if this distinction between the two forms of chemical energy is permissible). The author has been able to write with the authority of long experience in the works and in the laboratory, and his exhaustive method of treatment has not rendered

the subject either tedious or involved. It is, on the contrary, an eminently readable and attractive volume. It is divided into chapters describing the preparation and reactions of the diazo-compounds, their derivatives, and their constitution. In an appendix a short account is given of the author's new theory of their structure. This is not the place to enter upon a discussion of the subject, but a strong case is made out for the new view, which should stimulate fresh experimental work of an interesting character.

J. B. C.

Handbuch der Physik. By Dr. A. Winkelmann. Second edition. Fifth volume, second part: Elektrizität und Magnetismus, II. Pp. xiv+971; illustrated. (Leipzig: J. A. Barth, 1908.) Price 16 marks.

THE present portion of this encyclopædic treatise consists of electro-dynamics and induction, by K. Waitz; absolute measurements of magnetic and electric quantities, by A. Oberbeck; technical applications of induction, by Th. des Coudres; telephony, by L. Reil-stab; and the theory of electric phenomena, by L. Graetz. Important though every one of these sections is, it is doubtless to the last that the reader will turn first on account of the great developments of theory during the last decade; and especially will he turn to the chapters on electrons and on the electromagnetic equations for bodies in motion. We have stated in reviewing the previous parts that the treatise is not intended for continuous reading. It is essentially an encyclopædia, a book of reference. But it is the treatise *per excellence* to which reference should be made by all those who wish to know what has been done and what theories have been enunciated in the domain of physics.

LETTERS TO THE EDITOR.

[The Editor does not hold himself responsible for opinions expressed by his correspondents. Neither can he undertake to return, or to correspond with the writers of, rejected manuscripts intended for this or any other part of NATURE. No notice is taken of anonymous communications.]

The Condensation of Helium.

IN NATURE of March 12 I have found a note referring to my experiments on the expansion of helium, made in consequence of my determinations on the isothermals of helium, at -25° C. and -259° C., which yielded nearly -5° K. for the critical temperature of helium.

The prosecution of the experiments has shown that what I observed in expanding the gas was not the evaporation of solid helium, but solution phenomena of solid hydrogen in gaseous helium. I have communicated to the Amsterdam Academy a note on my experiments, which at the moment leave the condensation of helium a yet undecided question.

Of course, I have written the details to Sir James Dewar, and I hoped to do so to you to-day, but by pressing duties I cannot do it before to-night, and you will probably go to press before that letter reaches you. So I beg to be allowed to send you first this short notice.

H. KAMERLINGH ONNES.

Mendelian Characters among Shorthorns.

PROF. WILSON is welcome to any satisfaction he can obtain out of the Mendelian interpretation he gives to our statistics of coat-colour in Shorthorns. As a matter of fact, some readers may consider that the same interpretation is given with greater numerical accuracy on pp. 440-4 of our original memoir (*Biometrika*, vol. iv.). For example, we give 656 crosses of roan and whole red alone, resulting in 243 whole reds, eighty-five red and whites, and four whites. The remainder consists of 324 roans. Of this we say "the close approximation to the Mendelian number of the roans is noteworthy, but the appearance of 4(WW) is again impossible unless some of

the reds are to be treated as heterozygous." Why does Prof. Wilson reduce our total red roan crosses to 456, and leave out the inconvenient four whites? Why does he give only three whites crossed by white as giving three whites, while we dealt with ninety-one such crosses giving eighty-six whites, four roans, and one red? Why, further, does he leave out the whole of our Table I. on p. 441? We followed up the white cattle pedigrees, writing to the breeders about special cases, and finding in the great bulk of instances the crosses and colours stated in the Herd-book confirmed. If it be asserted that the colours given in the Herd-book are incorrect, or, still more vitally, that the confirmation of those facts given to us by reputable breeders are misstatements, then the only conclusion is that Mendelism cannot be discussed on the basis of the Shorthorn data. That is a logical position; it is not, however, logical to use the data, and escape inconvenient facts by the statement that they are due to errors or to deception, or to omission to enter calves (which we found on inquiry among English large breeders to be not so frequent as has been asserted).

The facts stated by us on p. 442 of our paper, which cannot at present be made fully public, show that there are probably latent colour determinants in white cattle which can be made patent if two individuals of pure white coat, but one of mixed race, be crossed. Recent experiments seem to show that the actual amount of pigmentation in the coat is an inherited character in mammals; no explanation, Mendelian or other, which overlooks the difference between whole and parti-coloured animals can in the present state of our knowledge be considered satisfactory. As it is, the parti-coloured cattle are being bred out, and the possibility of this shows that red and parti-colour are *not* interchangeable. This point is illustrated again by the fact that in whole red crossings about 3 per cent. of roans appear, but in parti-colour crossings about 8 per cent. of roans occur. There is at the bottom of this, I believe, a physiological fact, and I am not prepared to overlook it by saying, with Prof. Wilson, that 438 red by red matings gave twenty-five roans, which are to be put down as due to errors and misstatements because they do not fit his view of the case.

Within broad lines Shorthorns do show segregation in the results of the crossings; this is really the great idea embodied in the Mendelian view. It may be possible on a determinantal theory to offer a reasonable account of the Shorthorn data; such a theory would certainly follow recent Mendelian work in discriminating between whole and parti-colour coats. On the other hand, it is a possible attitude to discard the data as untrustworthy; it is not logical, I hold, to discard just as much as you please of the data and no more in order to make it fit the simpler Mendelian ratios.

KARL PEARSON.

Biometric Laboratory, University College.

THE validity of Prof. Pearson's criticism of the view that Shorthorn cattle are Mendelians turns upon the accuracy of my statements (a) that in the Herd-book roans are sometimes registered as reds and reds as roans; (b) that many white calves are not registered at all; and (c) that coloured calves are sometimes substituted for white ones. Unfortunately, these statements are all true, although the last one only need cause very serious regret. The following may make the position clearer.

A short time ago a very distinguished breeder was regretting the substitution of coloured calves and the difficulty of proving cases of substitution to be such. This breeder persistently uses white bulls in order to get roan calves from his red cows, and, in proof that red calves entered in the Herd-book as the progeny of reds and whites are probably substitutions, he mentioned that in all his experience he had got only one red calf from his white bulls and his red cows.

That red calf—a bull—came to Ireland, and is still alive. To the great disappointment of his owner, he has bred several white calves from roan cows.

First, by being the son of a white bull and a red cow, and, next, by breeding white calves from roan cows, this red bull disproves the theory that Shorthorns are Mendelians; but I had the privilege of seeing him this afternoon, and he is not red, *he is roan*. He is, however,

such a roan as might be mistaken for a red unless closely examined.

Here, then, is one of our most distinguished breeders referring to substitution, and making an error of description as regards the colour of a calf.

The last time I visited the farm where the above "red" bull is standing I saw some white calves, and this afternoon one of them, now six or eight weeks old, was missing. I asked the owner what had become of him, and got the reply, "I have sold him." This particular white calf may be referred to in the Herd-book by his breeder, but many another similar one is never referred to at all.

Prof. Pearson suggests that, if there are inaccuracies and misstatements in the Herd-book, "Mendelism cannot be discussed on the basis of the Shorthorn data." I do not agree. But, if not Mendelism, can biometric theories be discussed upon the same data?

The latter half of Prof. Pearson's letter does not bear much upon the present issue, but I should not be astonished, if his theories as to colour determinants and parti-colours are followed up, that each of the two races from which the Shorthorn is descended should split up into more than one variety.

Prof. Pearson thinks that, because I neglected the figures in the first part of his original paper, I was evading some of the data. This is not so. I did not notice that they comprised other data, for which I am sorry, because the ninety-one white crossings which gave eighty-six white calves, four roans, and one red, would have been helpful. I had not seen the original paper since the time it was published two years ago, and, when I conceived the idea that Shorthorns are Mendelians, I went straight to the two tables from which I quoted, in the belief that they contained all the relevant data collected by Miss Barrington and Prof. Pearson.

JAMES WILSON.

Royal College of Science, Dublin; April 8.

The Nature of γ and X-Rays.

If I am putting the correct interpretation on Mr. Barkla's letter in NATURE of February 6 (p. 319), I have to thank him for the admission that his experiments are not so contrary to the neutral pair theory as he had at first supposed.

Mr. Barkla still concludes, however, in favour of the ether pulse theory. He has compared the intensities of two secondary beams emitted by carbon under the influence of an unpolarised primary beam, the one returning on the track of the incident rays, the other moving in a perpendicular direction. His calculated ratio is 2:1; experiment gives 1.85 to 1 (*Phil. Mag.*, February, p. 293). Such an agreement has its value. But, at the same time, he finds that for harder rays the ratio drops to 1.45 to 1, with no sign of a limit. His theory is unable to predict this decline, far less to measure its amount. It is no compliment to the ether pulse theory to describe such incomplete successes as "absolutely conclusive evidence."

He invites me to suggest a theory of scattering which shall have as much success as his own. But, on the neutral pair theory, the laws of scattering must depend directly on the constitution of the atom, as to which it is scarcely possible to do more than speculate. It is not incumbent on me at this stage to frame an independent hypothesis by the success of which my older one is to be judged.

He wishes to avoid arguments founded on an experimental study of the γ rays. But it is quite legitimate to begin with the γ rays, and to carry the argument over to the X-rays, on the ground that there is an extremely close parallelism between the two types. Evidence of this sort cannot be avoided by resolutely facing the other way.

It will perhaps conduce to greater clearness if I state my position briefly.

(1) Nearly a year ago I pointed out that almost all the phenomena of γ and X-rays could be explained on a neutral pair theory at least as well as on an ether pulse theory. This applied particularly to all effects connected with the production of secondary cathode rays of high velocity, effects which are at the root of most of what has been observed.

(2) I have recently described some experiments carried out by Dr. Madsen and myself which seem to me to support my contention in the strongest way as regards the γ rays.

(3) Since X-rays and γ rays resemble each other so faithfully in most respects, particularly those connected with the high-speed cathode rays, I have therefore suggested that the experiments also support my contention regarding the nature of the bulk of the X-rays.

(4) There are a few outstanding phenomena of the X-rays which do not fit in so readily with a neutral pair hypothesis, particularly Marx's velocity experiment, and the diffraction experiments of Haga and Windt. These seem to prove the existence and activity of ether pulses. As regards Mr. Barkla's polarisation effects, I have indicated a possible way of explaining them on the neutral pair theory; but I am quite content to wait for the guidance of future experiments, amongst which Mr. Barkla's recent work will take its proper place.

(5) If I admit the existence of ether pulses, I do not thereby weaken my contention that the most important and effective part of γ and X-ray radiation is material. We know that ether pulses exist; it does not follow that they do everything. On the contrary, the evidence for the ether pulse theory is extremely weak in just this direction; there is a danger that the *post hoc* has been confused with the *propter hoc*. When I see a boy jerk his arm, and hear immediately afterwards a rattling on my roof, I know quite well that the motion of the boy's arm has set an air pulse going, but I do not conclude that one of my chimneys was in a dangerously explosive condition, and that the air pulse has precipitated the violent discharge of half a brick.

W. H. BRAGG.

The University of Adelaide, South Australia,
March 12.

The Corrosion of Iron and Steel.

A PAPER describing the investigation of the causes of rusting of iron was read in May, 1907, before the New York Section of the American Chemical Society by Mr. William H. Walker and others, and has been recently printed in this country. After criticising the various explanations which have been put forward of the rusting of iron in contact with water, the authors approve the suggestion of Whitney that the first step in the process is the escape into the liquid of iron in the form of positively charged ions. In confirmation of this, the authors state that they succeeded in detecting iron by chemical tests in water which contained only a trace of electrolyte, and was free from oxygen and carbon dioxide, after the water had been in contact with iron.

Such an explanation would apply to a fact which confronted me some years since when investigating the cause of the action of water on lead. Every precaution was adopted to bring a surface of metallic lead absolutely free from oxide into contact with water free from dissolved gases, with the expectation that if these conditions were fully complied with no lead would pass into solution. In the course of the investigation the precautions which were taken to secure the conditions specified gradually became more stringent, and the amount of lead passing into solution was correspondingly reduced; but when the utmost possible care had been taken, lead in very minute proportion was still detectable in the water by chemical tests. It is of interest to note that the proportion of lead was constant when the contact of water with lead had been brought about in repeated experiments with some variations in detail. The impression produced by these results on my own mind was that undoubtedly lead in the metallic state must have passed into the water, and upon re-consideration of the experimental work and its results I feel satisfied that this was the case, and that the lead probably passed into the water as iron did in the experiments made by Whitney and repeated by the American investigators, when they brought iron into contact with water under conditions similar to those which I had secured.

FRANK CLOWES.

The Grange, Dulwich.

THE GEOLOGY OF SOUTH VICTORIA LAND.¹

THE National Antarctic Expedition is to be congratulated upon the care and promptitude with which its scientific collections are being worked out by the staff of the Natural History Museum. The results are being issued with the fulness of illustration and the excellent form characteristic of the publications of that institution. The work has been thoroughly supervised and edited. The first volume has a general preface by Sir Ray Lankester, and a special preface by Mr. Fletcher, in whose department the work of this volume was executed; the biological work is being edited by Mr. Jeffrey Bell. The first volume deals with the geological work of the expedition, and contains two reports. The first, by Mr. H. T. Ferrar, records his observations upon the stratigraphical and glacial geology. It is accompanied by a valuable geological map of the district around MacMurdo Sound, based on the topographical survey by Lieut. Mulock, and by an admirable series of photographs, that are a valuable supplement to the text, but by whom they were taken is not stated. The geological specimens obtained were mainly collected near the *Discovery's* winter quarters, and on the opposite part of the mainland. The extended field observations and the large amount of material collected are clearly the result of most indefatigable and courageous work, under difficult and dangerous conditions, and are a most important addition to Antarctic geology. The geological formations at MacMurdo Bay are divided by Mr. Ferrar into four series: the recent volcanic rocks of the islands; the gneiss and granite that form the foot hills and the basement of the mainland plateau; a wide series of horizontal sandstones, the Beacon Sandstones, that form the plateau of southern Victoria Land; and some dolerite sills intrusive into the Beacon Sandstones. Unfortunately there is no definite evidence as to the age of these sandstones. Some plant remains were found in them, and are described by Mr. Arber, according to whom they are "unfortunately of little value botanically"; he calls them "carbonaceous impressions," "which in all probability are of vegetable origin." Mr. Arber concludes that the specimens "neither permit of any opinion as to the botanical nature or affinities of the fossils themselves, nor of the geological age of the beds in which they occur." Considering the extent and abundant exposure of these sandstones, the apparent rarity of organic remains in them is significant. Mr. Ferrar devotes three chapters to glacial observations, and describes Ross's ice barrier as a Piedmont glacier, formed of confluent flows of land ice. The evidence offered in support of this conclusion is not very convincing, but until the issue of the meteorological data collected by the expedition, it is better to suspend judgment upon this question; and it may be hoped that Lieutenant Shackleton's expedition will collect further information as to the intimate structure of this ice.

The second part of the volume is occupied by Dr. Prior's report on the rocks of South Victoria Land. This report is masterly from its combination of refined petrographic research with insight into the tectonic bearings of the microscopic evidence. Dr. Prior shows

that the volcanic rocks include basalts, kenytes, phonolites and trachytic phonolites; the dykes are of camptonite, kersantite, and banakite; and the basement rocks of South Victoria Land include granite, diorite, gneiss and a crystalline limestone, of which a specimen was found by Dr. Wilson. Dr. Prior's report contains an interesting discussion of the chemical relations of the rocks and their interpretation by the American quantitative system of classification. He shows that the district is a distinct petrographic province characterised by the association of limburgites with intermediate rocks, which are rich in alkali and contain anorthoclase as the predominant feldspar. He has calculated the percentage mineral composition of the rocks and assigned to them the names they would receive in the American quantitative classification, and he concludes (p. 120) that "the result shows that the classification supplies a variety of names to rocks not differing very widely in chemical composition."

The sequence of the volcanic rocks is a question of



FIG. 1.—The two lower men are standing upon the upper surface of sea-ice depressed by snow below water-level. National Antarctic Expedition.

much interest, especially as some field observations were regarded as showing that the trachytes were younger than the basalts; but Dr. Prior concludes from his study of the rocks that this view is improbable, and that the trachytes and kenytes preceded the basalts, as they did in the typical kenyte area in East Africa. The most widely interesting part of Dr. Prior's report is probably that discussing the geographical relations of South Victoria Land. He points out that the rocks are chemically allied to those of the Atlantic coast type, and not to those of the Pacific coast type. He, of course, recognises that, according to this use of the terms Atlantic and Pacific, the southern end of New Zealand must be regarded as of the Atlantic type, for the rocks of South Victoria Land are petrographically allied to those of Dunedin described by Dr. Marshall. An article in *NATURE* (in 1901, vol. lxi., p. 610) on the probable geological relations of Victoria Land pointed out that the sudden change in the geographical grain of southern New Zealand might very likely be continued into Ant-

¹ National Antarctic Expedition, 1901-1904. *Natural History*, vol. i. *Geology* (Field-Geology; Petrography). Pp. xii+160; 10 plates and 2 maps. (By order of the Trustees of the British Museum, 1907.) Price 30s.

arctica, and that accordingly the view suggested by Reiter that the mountains of South Victoria Land were the continuation of the mountain chain of New Zealand might require modification. The geological results issued in this volume show that, as expected, South Victoria Land is a high plateau broken off to the east by the subsidences which have formed the Ross Sea. Moreover, the suspected affinities between Victoria Land and New Zealand have been greatly strengthened by the discovery of the kenyte series of Ross Island; and the predictions in *NATURE* (vol. lxiii., p. 610) that "the palæontological results may be meagre" has proved only too true. Reiter's theory, however, requires one modification. The earlier descriptions of Victoria Land asserted the volcanic nature of the mountains on the plateau of South Victoria Land (as, *e.g.*, is the case in Mexico

rocks of the Pacific type, and subsidences those of the Atlantic type, is no real explanation; and though the coincidence is certainly widespread, it does not appear to be universal. The chemical character of the volcanic rocks can only be used as a test of the tectonic structure of coasts with important limitations; and the coastal types may still be regarded as based essentially on geographical structure, and not on the chemical composition of their lavas.

J. W. GREGORY.

NAVIGATION OF THE AIR.¹

THE author of this work at the outset states that he has no intention of writing a technical textbook, and his treatment of the subject, which embraces aerial navigation generally, is distinctly of a



FIG. 2.—Uplift of morainic material in the ice at the foot of Knob Head. National Antarctic Expedition.

and parts of the Andes), whereas the volcanoes, at least in the area reached by the expedition, were limited to the founded area in front of the plateau, as is the case in eastern Asia. Accordingly the structure of South Victoria Land may be of the inner or secondary Pacific type, and any remains of an outer or primary Pacific coast connecting New Zealand and Graham Land may be expected further to the east. The evidence is not yet sufficient for a final opinion, and an alternative interpretation, in deference to the petrographic evidence, is to regard the coast of South Victoria Land as of the Atlantic type; but there does not seem any clear reason why the distribution of volcanic rocks of different chemical types should be controlled by the nature of the crustal movements. The suggestion that fold movements produce volcanic

popular kind. Portions of the work, for example, those relating to ballooning and balloon photography, are dealt with in great detail, and show an intimate practical acquaintance with the subject; the section also relating to carrier pigeons, both in connection with ballooning and otherwise, is a welcome addition to the literature of the homing pigeon. On the other hand, some portions of the work are scarcely satisfactory, even from the popular standpoint, the chapter devoted to flying machines, for example, being a collection of scraps of information strung together without any definite scheme; on the face of it, this chapter is intended to be arranged in historical order, but

¹ "Airships Past and Present, together with Chapters on the Use of Balloons in Connection with Meteorology, Photography, and the Carrier Pigeon." By A. Hildebrandt. Translated by W. H. Story. Pp. xvi+364. (London: A. Constable and Co., Ltd., 1903.) Price 10s. 6d. net.

dates are not given where they are of importance, and even so well-known a worker in the field as Hargraves is practically ignored.

The illustrations are numerous, and, on the whole, are very good; of special interest is the photographic reproduction of a "double deck" Lillenthal machine in flight, which appears to be of the type used by the late Herr Lillenthal on the occasion of his last flight, when he unfortunately met with his fatal accident. Of the great variety of "birds' eye" photographs given, perhaps the most interesting are the cloud studies given in Figs. 125, 143, and 185; also a fine view of the pyramids of Egypt, Fig. 200.

The chapters on ballooning entitled "Ballooning as a Sport," "Scientific Ballooning," and "Balloon Photography," in addition to those on "Military Ballooning," make interesting reading, and constitute the most useful and trustworthy portion of the book; there is much information collected in pages devoted to these chapters that might be sought for elsewhere in vain. The account, however, is essentially of a popular kind; it is difficult to read these chapters without raising an "aeronautical appetite"; the description of over-sea ballooning and the illustrations of the *de la Vaulx deviator* are particularly interesting.



Lillenthal on his flying machine. From "Airships Past and Present."

It is when departing from the declared intention of the work that its author most lays himself open to criticism. Thus, on p. 17, in discussing the theory of the ascension of the *Montgolfiere*, there is a simple little pitfall into which the author has gratuitously precipitated himself. On the assumed barometric pressure of 30" of mercury, it is stated (we may presume correctly) that the weight of a cubic foot of air heated to 212° F. is 0.059 lb. Herr Hildebrandt then goes on to say:—

"At a height of 8330 feet, a cubic foot of air at a temperature of 32 deg. Fahr. weighs only 0.059 lb., and therefore a 'Montgolfiere' cannot reach a greater height than this, seeing that the lift then disappears, unless the temperatures, given in the above table, can be exceeded."

The assumption made here seems to be that the air within the balloon does not expand as the pressure is relieved by altitude, just as if the air inside the balloon were contained by a hermetically sealed pressure-proof envelope.

On p. 30 a description is given of an aneroid barometer which certainly is a mistake; either the word *tube* has been used in translation instead of *diaphragm*, or else the author describes a particular

aneroid (probably made by Bourdon, of Paris) instead of the aneroid as generally constructed; the almost universal practice of instrument makers is to employ a flexible diaphragm, not a tube as stated.

On p. 89 it is somewhat puzzling to find that most of the "dirigibles" have a greater content than that of their containing cylinder—according to the figures given. For example, a balloon 30 feet in diameter and 148 feet long is given as holding 137,500 cubic feet of gas; in view of the fact that a cylinder of these dimensions has a volume of only 105,000 cubic feet, this requires some explanation. Several other cases are equally incomprehensible.

On p. 96 the year 1862 is assigned to Phillips's "venetian blind" captive machine; this appears to be an error of about thirty years (antedate).

The fatal accident to Herr Lillenthal is stated to have been due to a want of adjustment, the machine turning over at a height of 50 feet from the ground. The authority for this version of the accident should be stated; the account, as published in NATURE (September 3, 1896), contributed by Prof. Carl Runge, from the evidence of an eye-witness (the assistant of Herr Lillenthal), made no mention of any error of adjustment, but attributed the capsizing to a sudden gust, which carried the machine to a height of 30 metres (100 feet), from which the fatal plunge took place.

In the chapter on carrier pigeons an account of certain experiments, stated to have been made with trained swallows, is given, but again no trustworthy authority is mentioned. A passage may be quoted as follows:—"An Antwerp trainer sent up some swallows and pigeons at the same time at Compiègne, in France. The pigeons covered the distance of 145 miles in 3½ hours, while the swallows arrived in 1 hour 7 minutes; the speed of the latter was therefore three times that of the former." Now the time taken by the pigeons appears to denote that there was no wind of consequence, and therefore the velocity of flight of a swallow may be calculated as 130 miles per hour, a conclusion full of improbability. Statements of this kind should only be inserted in a serious work after careful verification, and with the authority stated, place and time also being given, if possible.

NOTES.

THE fourth International Congress of Mathematicians was opened at Rome on Monday, April 6, in the presence of King Victor Emmanuel II., and the proceedings concluded on Saturday last, when an invitation was accepted to hold the congress of 1912 at Cambridge. The number of members shows a considerable increase on that of previous congresses, and a great deal of valuable work has been done in the sections. The Guccia medal has been awarded to Prof. Francesco Severi, for his papers on the geometry of algebraic surfaces. We hope to give an account of the proceedings of the congress next week.

It was announced at the meeting of the Institution of Naval Architects on April 8 that the council had gratefully accepted an offer from Mr. A. F. Yarrow, vice-president of the institution, to defray the cost, up to 20,000*l.*, of an experimental tank for research purposes to be erected at the National Physical Laboratory, provided that cost of maintenance for the first ten years was assured. A committee is to be appointed to carry out the scheme. Papers on the employment of the steam-turbine for various classes of ships took a prominent place in the proceedings of the meeting. Lord Cawdor was elected president of the institution upon the retirement of Lord Glasgow.

THE annual conversazione of the Selborne Society will be held at Burlington Gardens, New Bond Street, W., on Friday, May 1, from 7.30 to 11 p.m.

THE death is announced, in his eighty-seventh year, of Prof. Franz von Leydig, of the University of Bonn, distinguished by his studies in comparative histology and various works upon anatomical subjects.

MR. J. P. JOHNSON, of Johannesburg, has been commissioned by the Government of Orange River Colony to investigate and report on the Bushmen sculptures and paintings in that territory.

AT Issy les Moulineaux on March 11, M. Delagrangé, mounted upon an aeroplane, traversed the marked circuit seven times, the total distance being about 10 kilometres, in 9m. 15s. The motor with which M. Delagrangé's machine is provided is a forty horse-power light cylinder Antoinette.

THE Town Council of West Ham has resolved to confer the freedom of the borough on Lord Lister, "who was born in the county borough, and has rendered such illustrious service to the human race by his famous discovery of the antiseptic system of treatment in surgery and in a variety of other ways connected with science and the alleviation of pain and suffering."

REUTER'S Agency learns that the British Government has decided to take independent action regarding sleeping sickness by establishing a National Sleeping Sickness Bureau with headquarters in London. It will be remembered that the recent international conference in London collapsed mainly owing to the opposition offered to the proposal to establish any international bureau in London. Alternative recommendations in favour of Paris and Brussels were put forward at the time, but no agreement was come to on the question. The British National Bureau will be managed by a strong committee. Annual grants will be made by the Imperial and Sudanese Governments. To combat sleeping sickness, Great Britain and Germany are concluding a convention on the subject of joint measures for the prevention of the malady in Uganda and German East Africa. This is expected to be signed at an early date.

THE Naples Table Association for Promoting Laboratory Research by Women announces the offer of a fourth prize of one thousand dollars for the best thesis written by a woman, on a scientific subject, embodying new observations and new conclusions based on an independent laboratory research in biological, chemical, or physical science. The theses offered in competition are to be presented to the executive committee of the association, and must be in the hands of the chairman of the committee on the prize, Mrs. Ellen H. Richards, Massachusetts Institute of Technology, Boston, Mass., before February 25, 1909. The prize will be awarded at the annual meeting in April, 1909. The papers presented will be judged by a board of examiners, or by such specialists as they may choose. The board of examiners is constituted as follows:—*Biological sciences*, Dr. W. H. Howell, Johns Hopkins Medical School; *chemical sciences*, Dr. T. W. Richards, Harvard University; *physical sciences*, Dr. A. A. Michelson, University of Chicago.

We have received a somewhat belated copy (published in 1907) of No. 26 of the *North American Fauna*—U.S. Department of Agriculture—in which Mr. A. H. Howell classifies the little skunks of the genus *Spilogale*.

TO Nos. 3 and 4 of vol. xxix. of Notes from the Leyden Museum, Dr. E. D. van Oort contributes two papers on Papuan birds, in the second of which he describes, under the name of *Casuarus casuarus bistriatus*, an apparently new race of cassowary from the north coast of New Guinea. It is remarkable that this bird appears to be related to an Aru Island species, and thus quite different from those inhabiting the interior of New Guinea. A coloured plate of the head and neck is given.

TO *British Birds* for April Messrs. Witherby and Ticehurst contribute an article on the spread of the little owl in England. This owl cannot now be regarded otherwise than as an introduced species in England, owing to the fact that so many have been turned loose in various parts of the country. The process began in 1843 at Walton Park, Yorkshire, but the chief centres of spread have in recent years been Hampshire, Tring, Edenbridge in Kent, and Oundle. From Oundle the birds appear to have reached Woburn, where they breed freely. They also breed near Watford and other parts of Hertfordshire, while from the Kent centre these owls have colonised a considerable portion of the south-east of England.

IN an article on the seasonal colour-change in birds, published in the January number of the *American Naturalist*, Mr. C. W. Beebe states that certain tanagers and bobolinks, which had been prevented from breeding, were kept during autumn in a darkened chamber with a somewhat increased supply of food. The consequence was that the brilliant breeding-plumage was retained throughout the winter. Early in the following spring the birds were returned to normal conditions, and speedily moulted. The new plumage was, however, the nuptial dress, and not the dull winter livery, which was skipped. The sequence of plumage-change is not, therefore, invariable, but evidently in some degree dependent on external factors in the environment.

THE faculty of orientating their position, or the sense of direction, is considered by Mr. Benjamin Kidd, in the April number of the *Century Illustrated Magazine*, to be the most remarkable phenomenon in animal instinct. "This faculty of judging direction seems to bear no relation to the place of the animal in the general scale of intelligence. It is possessed to a considerable degree by dogs and cats, but in a very high degree by seals, which find their way back year after year to their rookeries from enormous distances in the open sea. It reaches a high degree of perfection in migratory birds not otherwise noted for intelligence. . . . The turtles which annually visit Ascension Island to deposit their eggs afford another example of the perfection of this instinct. How these reptiles can find this comparatively small speck of land in the midst of a vast ocean is, with our present knowledge, unaccountable."

Two pamphlets dealing with the food of American birds have just come to hand. In the first of these (from the Year-book of the U.S. Agricultural Department for 1906), Mr. W. L. McAtee gives a list of species feeding upon scale-insects, among which those included in the States under the name of grosbeaks occupy a prominent position. According to the second paper, which is by the same author, and forms Bulletin No. 32 of the Bureau of the Biological Survey, the birds last-named are valuable in other respects to the agriculturist and horticulturist. It should be mentioned that in America the scarlet cardinal and other members of the genus *Cardinalis* are commonly termed grosbeaks, and it is to this group that the remarks

of the author apply. These birds are much less exclusively vegetarians than other members of the finch tribe, nearly half their food-supply consisting of animal substances. Moreover, the five species discussed in the pamphlet consume, on the average, nine times more wild seeds than grain and fruit, while the proportion of noxious to useful insects devoured by them is nineteen to one. Cardinal grosbeaks and their relatives are, therefore (after due allowance is made for certain injuries they inflict), of great economic value to the farmer, by whom they ought to be encouraged and protected.

We offer our congratulations and best wishes for a successful life to the Transvaal Biological Society, the first meeting of which was held at the Transvaal Museum, Pretoria, on January 17, Dr. Theiler, C.M.G., being in the chair. We are unable to find space for descriptions of the papers read at the opening meeting, but the titles are given among our reports of societies and academies. The honorary secretary and treasurer of the society is Dr. L. H. Gough.

An account of the sporangium in the Ophioglossaceæ, contributed by Mr. L. L. Burlingame to the *Botanical Gazette* (July, 1907), is based on an examination of the middle and later stages of development of the sporangium of *Ophioglossum reticulatum*. Irregular divisions of the sporogenous tissue, a remarkable difference in the stages of division of the mother cells, and an absence of definite arrangement in the positions of nuclear spindles in adjacent cells, were the chief points brought out in the investigation. A multipolar spindle changing to a tripolar, and subsequently to a bipolar, condition is figured. The development of the sporangia in the three genera *Ophioglossum*, *Botrychium*, and *Helminthostachys* is collated in tabular form.

DR. H. VON SCHRENK communicates to the report of the Missouri Garden for 1907 two interesting notes on growth connected with natural injuries to trees. In the one case sycamore buds were caught by the late frosts, with the result that the outer buds on the branches were killed, but the lower buds survived, and there was also a well-marked development of adventitious buds. The second note refers to hollow or button-like branch cankers formed on shrubs of *Rhododendron maximum* as a consequence of the slow growth of the healing callus tissue. Mr. H. Hus records his experiments on the germination of *Hydrastis canadensis*, a sylvestral plant yielding rhizomes that are officinal in certain pharmacopœias. The same author instances a case of vireescence in the petals of *Oxalis stricta*, and mentions that the character was transmitted to the second generation.

The annual report of the botanic station, agricultural school, and experiment plots in Dominica contains also an account of the inception and development of these establishments, and illustrations of local views. In Dominica much attention has been paid to the cultivation of limes; the establishment of a spineless variety of the fruit, and the introduction of the system of manufacturing citrate of lime for export, are expected to improve the industry. The characters of the spineless lime and the qualities of the juice are compared with those of the ordinary variety. Another feature has been the dissemination of the value of budding and grafting; in this connection, experiments in grafting cacao are noteworthy; training in these methods forms a part of the curriculum provided at the agricultural station. The manual experiments on cacao plots indicate that various manures may be profitably applied, but the best results were obtained with mulchings of grass and lawn sweepings.

A REVISED list of the flora of Natal, compiled by Mr. J. M. Wood, has been published in the eighteenth volume (part ii.) of the Transactions of the South African Philosophical Society. The preponderance of the order Compositæ is very marked, and is partly due to the numerous species of *Helichrysum*, *Senecio*, *Berkheya*, and *Vernonia*. The next largest orders are the Gramineæ and Leguminosæ, then the Liliaceæ and Orchidaceæ. The genera *Crassula*, *Indigofera*, *Royena*, *Selago*, and *Mahernia* are well represented. The author recognises three botanical regions, and alludes to the palms *Hyphaene crinita* and *Phoenix reclinata*, *Strelitzia augusta*, and the handsome shade tree, *Trichilia Dregeana*, that grow in the coastal region. In the midlands the hills are grass-clad, and the forests are generally confined to the valleys, where two species of *Podocarpus* and *Ocotea bullata* occur. In the uplands, *Callitris cupressoides*—one of the three conifers indigenous to the country—forms isolated forests; two plants with conspicuous flowers are *Ranunculus Cooperi* and *Anemone Fanningii*, and the well-known *Galtonia candicans* is found.

In the *Reliquary* for April, a noteworthy article is that by Mr. E. D. Goddard on certain fibulæ of the La Tène type found in Wiltshire, which may be dated about 200 B.C. This is a useful supplement to the discussions on the same subject by General Pitt-Rivers, Prof. Ridgeway, Mr. Reginald Smith, Dr. Arthur Evans, and others. The writer traces twenty-six examples found in England, of which Wiltshire and the adjoining counties claim no fewer than twenty—a fact which he thinks may imply a special connection of this part of England with Gaul in the period preceding the Roman invasion. In the same number Mr. J. L. Cowan contributes a well-illustrated article showing the evolution of house building in the Pueblo region of New Mexico, Arizona, Utah, and Colorado.

THE Observatory of Rio de Janeiro is doing very useful work in collecting and publishing in its *Boletim Mensal* series of meteorological observations made at various places in Brazil. In the number for January-March, 1907, which we have recently received, are to be found—in addition to the current tri-hourly observations at the observatory and ten-day means for other stations—monthly and annual summaries referring to several departments for 1906. Monthly and annual rainfall values are also given for Recife (Pernambuco) for fifty-four separate years between 1842 and 1906.

A copy has just reached us of the observations made at the Royal Magnetical and Meteorological Observatory at Batavia in 1905; the principal change for this year is the omission of the hourly values of atmospheric humidity. In this valuable series of hourly readings the meteorological observations date from 1866, the magnetical from 1868; in both of these elements the influence of the moon has been taken into account. The seismometrical observations date from 1898. The present volume includes the results of meteorological observations for 1901-5, and for 1866-1905; we also note that a discussion of the rainfall at 700 stations in the archipelago is in the press. Three important appendices accompany the volume; one of these gives a list of magnetic disturbances during 1880-1899; some of the statistical results have been published by the Amsterdam Academy. We hope to refer to the others, dealing with meteorological subjects, later on.

THE Survey Department of the Ministry of Finance of Egypt has issued an account of the magnetic observations made in Egypt during the ten years 1895-1905, together with a summary of the observations made previously in northern Africa. According to the charts which embody the

results, the declination at Alexandria has decreased from 13° to 3° west, and the dip from 47° to 42° , in the last 100 years. The lines of equal declination at present run nearly parallel to the Red Sea, where the declination is 2° . At the Victoria Nyanza it is 7° . The lines of equal dip run east and west, the dip being 43° north at Port Said and 23° south at the Victoria Nyanza. The horizontal force varies from 0.30 at Cairo to 0.35 at Aden, and the curves of equal force are not unlike ellipses with their major axes east and west and their centres in the Gulf of Aden.

A PAPER on "The Possibility of a Topography of the Air, based on Balloon Observations with Special Theodolites," by Captain C. H. Ley, appears in the last issue of the Quarterly Journal of the Royal Meteorological Society (vol. xxxiv., No. 145). The paper forms a further contribution to the investigation of the upper atmosphere, which now plays so important a part in meteorological work. In all experiments hitherto made to determine the motion of the upper air from the drift of pilot balloons, it has been necessary either to observe the motion of the balloon through two theodolites at either end of a measured base line, or, if only one theodolite was available, to assume a value for the upward velocity of the balloon. In the present experiments only one theodolite was used, and the remaining data necessary for determining successive positions of the balloon were obtained from measurements of its apparent diameter made with a special arrangement of cross-wires in the eye-piece. Allowance was made for the expansion of the balloon by assuming approximate values for the rate of decrease of temperature and pressure with height, and calculating the volume of the balloon from the usual laws for the expansion of gases. The experimental and other difficulties which arise are considerable, and it can hardly be claimed that the author has succeeded in overcoming them completely, but the advantages of a method which dispenses with a second theodolite are considerable, and it is to be hoped that the experiments will be continued. The results obtained go to show that the ascensional velocity of a pilot balloon is far from uniform, as is generally assumed in experiments with only one theodolite. The most striking variations were found to occur as the balloon passed over a ridge of hills. In the vast majority of cases, when this occurred a marked increase in the rate of ascent was observed as the balloon approached the ridge, even though it was at an altitude of several thousand feet above the summit. The increase in the rate of ascent of the balloon is regarded as direct evidence of an increase in the vertical component of the motion of the air in which it floats, so that the topography of the land appears to have a close connection with the vertical motion of the air even up to altitudes of 20,000 feet.

SOME excellent photographs and drawings of the new Charing Cross Station of the South-Eastern and Chatham Railway are given by Mr. C. S. Lake in *L'Ingegneria Ferroviaria* of March 16. It is noted that the quantity of steel used in the construction of the new roof was 1000 tons.

THE School of Mines at Golden, Colorado, with 320 students, possesses exceptional environment for mining and metallurgy, and the current issue of the school Bulletin (iv., No. 2), published semi-annually by the Technical Mining Society, affords evidence that excellent work is being done by the students. Mr. F. H. Cronin has an outline of the course in steam-power plant design. Mr. D. Hollis and others contribute an admirable paper

on the electrometallurgical treatment of copper slimes, and Mr. C. D. Test gives an account of the occurrence, production, and commercial value of monazite.

AN important contribution to the knowledge of the economic geology of Peru is afforded by a monograph, by Mr. Enrique I. Dueñas, on the mineral resources of the department of the Cuzco, forming *Boletín* No. 53 of the Corps of Peruvian Mining Engineers. Descriptions are given of the gold washings of the river Nuisiniscato, of the nickel and cobalt ore deposits of Vilcabamba, of the Silurian gold veins in Paucartambo, of the oil fields of Pallpata and Pusi, of the Tertiary and Mesozoic coal-fields of the department, of the iron-ore deposits of Chumbivilcas, and of veins of copper sulphide, argentiferous galena, gold quartz, and stibnite in various parts of the department. The occurrence of mica in pegmatite dykes, of asbestos, of tripoli, and of other non-metallic minerals of economic value is also recorded.

AT the Institution of Mechanical Engineers on March 27, papers were read by Dr. F. J. Brislee on combustion processes in English locomotive fire-boxes, and by Mr. L. H. Fry on combustion and heat balances in locomotives. Dr. Brislee's object was to ascertain what percentage of carbonic oxide escaped unburned, and to this end he carried out interesting trials on the London and North-Western Railway. Mr. Fry gave selections from the data published in "Locomotive Tests and Exhibits, Pennsylvania Railroad," at the St. Louis Exhibition, a book which was issued in 1905. Both papers represent a great deal of labour, and the carefully tabulated experimental results will undoubtedly prove of permanent value, although it is doubtful whether either paper is likely to affect locomotive practice.

AT the last meeting of the Institution of Engineers and Shipbuilders in Scotland, Mr. M. Kahn read a paper on the practical application of reinforced concrete. He expressed the opinion that reinforced concrete was the best form of construction when properly handled, and the worst when improperly handled. Such being the case, it behoves the owner and the architect to ensure that only the best class of contractor is employed on his work. Contractors can only afford to carry out work which will ensure them a fair amount of profit, and if, by the adoption of reinforced concrete, the owner is saved 10 per cent. of the cost of construction, it is advisable to grant the contractor any extra saving, so as to ensure his giving a construction which will prove satisfactory in every respect. When owners and engineers realise this point, and act accordingly, reinforced concrete will then reach that position in the category of structural materials where it justly belongs.

THE preliminary official report on the mineral production of Canada in 1907 shows that the total value of the output was \$6,183,477 dollars, the largest total ever reached. Compared with the production of the previous year, there are some decreases to record, such, for instance, as in gold and lead, in corundum, feldspar, and graphite, but these are more than counterbalanced by large increases in the production of pig iron, silver, asbestos, coal, natural gas, petroleum, and cement.

A REPORT on the work and results of the Khatanga Expedition, organised in 1905 by Dr. F. Schmidt, with the cooperation of the Russian Geographical Society, appears in the February number of *La Géographie*. The work of the expedition was divided into three sections—the exploration of the higher course of the Khatanga, and its relations with the tributaries of the Yenisei; the discovery of the main features of the lake region, and the course of

the Moiero; and, finally, the exploration of the extreme north of the Khatanga and Anabar. A map of the Khatanga and its upper branches shows the important additions to geographical knowledge resulting from the expedition, which has proved that the supposed immense lakes of that district do not exist. In addition, geological information of great interest has been obtained, together with important zoological and ethnographic collections.

PROF. ARISTIDE FIORENTINO, writing in the *Rendiconti* of the Lombardy Academy, directs attention to a school-room experiment for showing the absorption of energy by an acoustic resonator. He places the resonator in the neighbourhood of a singing flame, and if the two are in unison the vibrations of the flame instantly cease. The author has further used the singing flame as a test for syntonised resonance. Thus he has demonstrated in the case of a gramophone horn that those tones are most readily absorbed which are most strongly reinforced. The failure to take account of this fact is no doubt partly the reason why gramophone reproductions usually represent little more than a caricature of the original music. The same records are habitually snorted out through horns of all sizes and shapes, whereas if the free vibrations of any particular horn were reduced by the absorbing action of similar horns in the manufacture of the records, the results would be much better.

Himmel und Erde for March contains the report of a popular lecture on electric transmission of power to great distances, delivered by Prof. H. G6rges, of Dresden, before the Scientific Association of Berlin. The lecturer deals in a clear manner with the generation of electric current by the motion of a conductor through a magnetic field, and shows how the modern dynamo is merely an application of this principle. The generation of the power to drive the machines is also treated, special attention being given to the utilisation of the waste gases from blast furnaces and to water power. Prof. G6rges believes that the greatest future lies open to the simple alternating as distinguished from the triphase current, and instances the recent installation of the Ohlsdorf-Hamburg-Blankensee electric railway as a step in this direction. The pressure in this case is 6000 volts, with 30,000 for transmission to distant portions of the line.

The London Geological Field Class excursions, conducted by Prof. H. G. Seeley, F.R.S., for the study of the Thames Basin, will commence on Saturday, May 9. Mr. J. W. Jarvis, St. Mark's College, Chelsea, S.W., is the honorary secretary.

A SECOND edition of the "Guide to the Archives of the Government of the United States in Washington," by Messrs. C. H. V. Tyne and W. G. Leland, has been published by the Carnegie Institution of Washington. The new issue has been revised and enlarged by Mr. W. G. Leland; the usual work of correcting errors, verifying statements, supplementing the bibliographical data, altering classification when required by administrative changes, and bringing the accounts to date, has been performed, and in several cases the text has been much amplified.

OUR ASTRONOMICAL COLUMN.

THE RECENTLY DISCOVERED SATELLITE OF JUPITER.—The observations made at Greenwich of the object near Jupiter, recently discovered by Mr. Melotte, tend to confirm the assumption that this object is in reality a satellite, the eighth of the known Jovian satellites.

In the April number of the *Observatory* (No. 395, p. 177) there appears a note which states that the observed positions, from January 27 to March 23, may be satisfied by

the assumption that the satellite has a retrograde motion; the pole of the orbit plane lies in R.A. = $334^{\circ} 48'$, N. dec. = $56^{\circ} 44'$; distance from Jupiter 0.24 astronomical unit; daily motion about Jupiter, $0^{\circ}.266$. On February 18 it passed the minor axis of the apparent ellipse. The arc yet observed is so small that any solution can only be tentative, but it is hoped that sufficient observational material has been gathered to ensure the re-discovery of the satellite at the next favourable presentation.

MUTUAL OCCULTATIONS AND ECLIPSES OF JUPITER'S SATELLITES.—A partial occultation of Ganymede by Europa was observed by Mr. Whitell on January 25, the phenomenon lasting for some fifteen minutes. Prof. Oudemans recently published some ephemerides for occultations to take place in June next, but in No. 395 of the *Observatory* (April, p. 178) there appears a list of times at which occultations will take place during the present month. In the following extract the first Roman figure indicates the eclipsed, the second the eclipsing, satellite:—April 17d. 10h. 41m., II., III.; 17d. 14h. 17m., II., I.; 21d. 12h. 19m., IV., II.; 22d. 9h. 41m., IV., III.; 22d. 11h. 27m., I., II.; 28d. 13h. 29m., IV., III.

THE TRANSIT OF MERCURY, NOVEMBER, 1907.—In No. 4238 of the *Astronomische Nachrichten* (March 9, p. 218) M. Gautier records the results of the observations made, at the Geneva Observatory, of the recent transit of Mercury. Neither the bright outer ring nor the central luminous spot was observed at any time during the transit. Times of the contacts and the positions of Mercury referred to the sun's limb at different times during the transit are given, and it is recorded that M. Pidoux, using the Plantamour equatorial of 271 mm. aperture, found the apparent diameter of the planet's disc to be $8''.4$, an amount sensibly less than that given by the ephemerides.

PARALLAX OBSERVATIONS.—The results of various parallax observations made by Dr. Karl Bohlin at the Stockholm Observatory appear in No. 4240 of the *Astronomische Nachrichten* (March 23, p. 247). The first object considered is a nebula, G.C. 1532, and the second an adjacent star, Lalande 14512. Their respective parallaxes are $-0^{\circ}.036$ and $-0^{\circ}.058$, the Br6nnow relative corrections for the aberration constant being $+0^{\circ}.186$ and $+0^{\circ}.149$ respectively, corrections to which Dr. Bohlin directs special attention on account of their magnitude. The corresponding figures for Bossert 947 (=Lalande 18115) and 61 Cygni are $+0^{\circ}.085$ and $+0^{\circ}.363$ for the parallaxes, and $+0^{\circ}.102$ and $+0^{\circ}.048$ for the corrections.

ASTRONOMICAL PHOTOGRAPHY WITH PORTRAIT LENSES.—Some good examples of celestial pictures taken with portrait lenses are reproduced in No. 187, vol. xiv., of the Proceedings of the American Philosophical Society (October-December, 1907, p. 417), in order to illustrate a paper by Prof. Barnard on the subject of astronomical photography. Prof. Barnard, in the first place, discusses the great advantages accruing from photography in the correct delineation of celestial objects, and then points out the special suitability of the earlier portrait lenses of large aperture for this purpose. This is followed by a discussion of each of the objects shown, including nebulae, star clusters, meteor trails, comets, &c. Most of the pictures were taken with the 10-inch Brashear doublet of the Bruce telescope.

THE HARVARD COLLEGE OBSERVATORY.—Prof. Pickering's report of the work done at the Harvard College Observatory during the year ended September 30, 1907, is the sixty-second of its series, and contains the usual brief summary of an immense amount of work. With the 11-inch Draper telescope, 356 photographs were secured, making 17,035 in all, and with the 8-inch Draper telescope the taking of 611 photographs brought the total to 34,886. The spectra of 456 stars, taken with the 11-inch instrument, were studied and classified by Miss Cannon, thus bringing near to completion a catalogue of the spectra of more than 1200 stars north of declination -30° . 2710 stellar photographs were taken at Arequipa, the total numbers now taken with the 13-inch Boyden and 8-inch Bache telescopes being 11,847 and 38,224 respectively. Other results, too numerous to mention here, are contained in the report, and it is announced that to private

individuals a nominal charge will in future be made for the Harvard publications.

THE SATURN PERTURBATIONS OF VARIOUS COMETS.—An abstract (No. 3) from the *Archiv der deutschen Seewarte* (vol. XXX., 1907) contains an important mathematical discussion of the perturbations of several comets by Saturn. The first-order perturbations of comets 1889 V., 1896 VI., and 1903 V. (Brooks) are discussed, and the work has been carried out by Dr. Johannes Wendt.

THE GAMES OF NORTH AMERICAN INDIANS.¹

IT has been known that Mr. Stewart Culin, formerly of the Free Museum of Science and Art in Philadelphia, and now of the Brooklyn Institute Museum, has for many years been engaged in a study of the games of the American Indians, and his monograph on the subject has recently been published in the "Twenty-fourth Annual Report of the Bureau of American Ethnology." The value of the memoir can partly be judged by the fact that, with the full index, it extends to 846 pages and contains 1112 figures in the text, in addition to twenty-one plates. The memoir itself is practically an illustrated catalogue of specimens in various museums, combined with extracts from numerous authors. Students of this interesting and suggestive branch of ethnology have now for the first time a mass of data at their disposal, and it is to be hoped that other regions of the world will be treated by equally qualified investigators in a similarly thorough manner. Some material for such studies occurs scattered in various publications and in unpublished museum specimens, but more field-work is necessary before anything so complete as Mr. Culin's monograph can be accomplished.

The collection has been confined to games in which implements are employed, but Indian children have many amusements played without accessories which belong to a different category from those described by Mr. Culin. It is to be hoped that these will eventually be studied, as they are of equal interest with the others.

The indigenous games of the American Indians, excluding purely children's games, may be divided into two groups:—(1) games of chance; (2) games of dexterity. Games of pure skill and calculation, such as chess, are entirely absent. In the first group are:—(1) games in which implements of the nature of dice are thrown at random to determine a number or numbers, and the sum of the count is kept by means of sticks, pebbles, &c., or upon a counting board; (2) games in which one or more of the players guess in which of two or more places an odd or specially marked lot is concealed, success or failure resulting in the gain or loss of counters. In the second group are:—(1) archery in various modifications; (2) a game of sliding javelins or darts upon the hard ground or ice; (3) a game of shooting at a moving target consisting of a netted wheel or a ring; (4) the game of ball in several highly specialised forms; (5) the racing games, which are less related to and complicated with the ball game. In addition, a few other games are described, but no allusion is made to introduced games, such as cards and board games.

References to games are of common occurrence in the legends and myths of various North American tribes. They

¹ "The Games of the North American Indians." By Stewart Culin. Paper by Fourth Annual Report of the Bureau of American Ethnology, 1902-3. Pp. 31-106. (Washington: Government Printing Office, 1907.)

usually consist of a description of a series of contests, in which the first man or culture hero overcomes some opponent or foe of the human race. The primal gamblers are the Divine Twins, the miraculous offspring of the Sun, who are the principal personages in many Indian mythologies. They, who are the morning and evening stars, live in the east and the west, ruling day and night, summer and winter. Their virgin mother, who also appears as their sister and wife, is constantly spoken of as their grandmother, and is the Moon or the Earth, the Spider Woman, the embodiment of the feminine principle in nature. Always contending, they are the original patrons of play, and their games are the games now played by men. Mr. Cushing thus described the Twins in his account of the Zuñi War Gods:—

"Lo! and of Chance and Fate were they the masters of foredeeming, for they carried the word-painted arrows of destiny, like the regions of men, four in number. And they carried the shuttlecocks of divination, like the regions of men, four in number. And they carried tubes of hidden things . . . and the revealing balls thereof. . . . Yea, and they bore with these other things, the feather bow and plume arrow of far-finding, tipped with the shell of heart-



FIG. 1.—San Carlos Apache Indians playing hoop and pole, Arizona. From a photograph by Mr. S. C. Simms.

searching; and the race sticks of swift journeys and way-winning, two of them, the right and the left, and the pursuer and the pursued of men in contention. All these things wherewith to divine men's chance, and play games of hazard, wagering the fate of whole nations on mere pastime, had they with them."

The gaming implements of most North American Indians "are almost exclusively derived from these symbolic weapons." Thus the stick dice are either arrowshafts or miniature bows, and a similar origin may be asserted for the two or four bones employed in the hand-guessing game or in the four-stick game. Counting sticks in general and the numerous sticks of the widely spread stick game are arrows. The engraved and painted tubes used in the guessing game are arrow shaftments, and this variant probably arose in a country where strong, hollow reeds were used as arrows. In the games of dexterity we also find bows and arrows, often associated with the netted shield. The snow-snake, or game in which missiles are hurled along snow, ice, or frozen ground, appears to be confined to the northern range of tribes within the limit of ice and snow; the projectiles are apparently

derived from clubs, bows or arrows, and may be referred to the weapons of the twin War Gods.

The opposing players are frequently the representatives of the two War Gods, and gaming implements are among the objects sacrificed upon the altar of the Twins Zuñi. In general, games appear to be played ceremonially, as pleasing to the gods, with the object of securing fertility, causing rain, giving and prolonging life, expelling demons, or curing sickness. There is no direct evidence of the employment of games in divination, apart from an observation by Cushing.

The game of hoop and pole, like the dice game, was played throughout the entire continent north of Mexico. It consists essentially in throwing a spear or shooting an arrow at a hoop or ring, the counts being determined by the way in which the darts fall with reference to the target. The game is remarkable for the wide diversity in the form of the implements employed, as well as in the method of play. A common and most widely distributed form of the hoop is twined with a network resembling



FIG. 2.—Altar of War God, Zuñi, New Mexico, with corn-rod darts used in the ring (or hoop) game. From a photograph of the reproduction in the United States National Museum.

a spider's web, the counts being determined by the particular holes which are penetrated by the darts. The author regards the plain hoop as a modification of the netted hoop, which represents the net shield of the twin War Gods. This object, which the Twins derived from the Spider Woman, is a feminine symbol, and may be used as an amulet. The dart or arrows are masculine. Dr. G. A. Dorsey, who has studied the symbolism of the ring employed in the Sun dance of the Arapaho, says it is symbolic of the creation of the world, for it represents the sun, earth, sky, water, and wind. Although Mr. Culin states "there is no record of women participating" in this game, it is played, as he himself notes, by Hopi maidens as a part of the prolonged Oraibi Oaqól ceremonies (H. R. Voth, Field Columbian Museum, Anth. Series, vi. [1903], p. 42). Though this cult is largely concerned with producing rain, it seems to be essentially a germination ceremony, and probably has reference to the maturation of the maidens. Mr. Culin adduces other

evidence in support of a fertility significance for this game, but he does not make any special allusion to it. Amongst some tribes the game is mythologically connected with the increase of buffalo; indeed, the Cheyenne and other Plains Indians call it the "buffalo game." The game had a religious character among the Apache, and probably this held good everywhere.

Probably connected with the foregoing is the widely spread game played by one person which consists of catching a ring, perforated object, or a ball on a peg. Dr. G. A. Dorsey says the Klamath always play it in winter; it is called "splitting or punching out the moon," and in this way the winter months are shortened and the advent of spring is hastened.

Ball games are well developed in North America, and Mr. Culin deals with them as fully as possible. The game of cat's cradle receives some attention, and various figures are illustrated, but as no instructions are given as to how they are made, much of the information is of little value. Mrs. Jayne's remarkable book on the subject is not referred to, neither is the magical aspect of the game among certain Eskimo as recorded by Boas on the authority of Captain Comer. The holy spiders taught the game to the Navaho, but calamity would befall if it were played at any other time than winter. The Zuñi explain cat's cradle as the netted shield of the War Gods, the game having been taught to them when little boys by the Spider Woman for their amusement. Owing to the ubiquitous nature of this pastime, it is evident that the Zuñi explanation of its origin is purely secondary, and was invented to bring it into their mythological system. We may suspect that the same may have happened for the hoop and pole game, in spite of Mr. Culin's belief that the oldest forms of existing games occur in the southwestern United States. Lack of space precludes due mention of the numerous minor amusements described by the author, though they are of considerable interest.

In introducing the memoir, Prof. W. H. Holmes, Chief of the Bureau, states that "the paper practically creates the science of games, and for the first time gives this branch its proper place in the science of man." This eulogy is somewhat exaggerated, as others on this side of the Atlantic have directed attention to the ethnological value of the study of games, and while Mr. Culin has produced a memorable monograph of lasting value, he can hardly be said to have introduced therein any general principles that had not previously been enunciated.

A. C. HADDON.

NERVE AS A MASTER OF MUSCLE.¹

WE have on the table before us two muscles. The animal was dead when they were taken from it a short while ago. But the animal was, as we are ourselves, an assemblage of organs, and many of these organs go on living for a certain time after the animal, as an animal, is dead. Hence these muscles, carefully removed, are still alive. We notice a marked difference between their behaviour now. To understand the behaviour of organisms we have to think of them as processes rather than as structures. An animal is something happening. The function of muscles is to contract. Of the two muscles now before us, one still goes on contracting, although quite isolated from the body of which it formed a part; but the other does not contract, although that is its function in the body. The muscle which still goes on contracting is the heart; the other is a muscle like the biceps of our own arm. We might think that, as it rests there motionless, it is not alive. It is, however, fully alive. We can satisfy ourselves of that. If I apply to it a faint electric current, it answers by exhibiting its functional activity—it contracts. Yet it does not contract of itself, nor will it, however long we may preserve it; it will die without of itself even contracting once. What is the significance of this difference between the two?

The secret of this difference is largely an affair of the nervous system. The tie between muscular activity and nervous activity is always close; but it is very different in

¹ A discourse delivered at the Royal Institution by Prof. C. S. Sherrington, F.R.S.

different muscles. The nervous system has been called, with a picturesque truth, the master-system of the body. It controls the action of organs; it controls, quite especially, the activity of the muscles. This heart which we see beating here receives nerves. One of those nerves when stimulated will cause it to contract less, the other to contract more. The contraction of the heart is its "beat." The vagus nerve slows the beating, the other nerve quickens the beating.

The heart is a tubular muscle; it drives blood through itself. When it contracts it squeezes the blood from it into the arteries, and so the blood flows to feed all the myriads of minute lives—cells—composing the whole complex living animal. The lives of these myriad minute entities all depend on their supply of blood, and therefore the life of the whole creature depends on the contraction of the heart. At each beat the heart by squeezing the blood out of its arterial end maintains the flow of blood, and this flow resulting from its own contraction refills it, because the blood returns to it by the veins.

This beating is all which the heart has to do. Whatever happens it must continue to do this, or the creature perishes. Life-long, night and day, winter and summer, it must do this. Whatever act the creature may be accomplishing, sitting, walking, feeding, sleeping, catching its prey, or escaping its enemies, this beating must go on, in the frog about ten times a minute, in ourselves about seventy times a minute. The task is monotonous itself. How admirably is the heart muscle adapted to fulfil it!

Self-adjustment to meet the environmental conditions differentiates animate from inanimate nature. As characteristic as this self-adjustment itself is its constant trend toward what has sometimes been termed "purpose." Animate objects are observed to adjust themselves to their own advantage, that is, so as to prolong their individual existence or that of their species. The more we know of them the more complete appears to us this trend in their reactions. The living organism advantageously adapts itself to its surroundings; and every part of a living organism exhibits this power. The heart-muscle reveals it clearly. It must not tire, and in normal circumstances the healthy heart, unlike other muscles, shows no fatigue. Its beat must always be strong enough to press its contents over into the artery against considerable resistance which opposes it. A heart-beat which did not expel the blood would be useless, worse than useless, wasteful, because it would be energy spent in vain. Its task can be roughly likened to that of a man with a bucket who has to keep lifting water from a tank at his feet to pour it over a wall of certain height before him. If he lift the bucket much above the wall he expends more energy than he need do; if he lift it less than the wall's height his work fails altogether. If he still, when the bucket is emptied, keep it above the wall's height, his work stops, although his effort does not.

The heart, whether its stimulus be weak or strong, beats always with sufficient power; it thus avoids the useless labour of a beat too weak to fulfil the office of a beat. If the heart were to give too prolonged contraction it would defeat its own purpose; after its beat, which empties it of blood, it must relax to refill for the next beat; to keep contracted would be for its purpose as harmful as to cease from beating; it would stop the blood instead of pumping it onward. In harmony with this, we find a prolonged stimulus to the heart does not keep the heart contracted; after the heart has replied to the stimulus by a beat it exhibits a refractory phase, during which it pays no attention to the further stimulation, and relaxes; and only after it has fully relaxed does it again pay attention to the stimulus and contract, that is to say, beat again. In short, it replies rhythmically to a continued stimulus which would keep the other muscle continuously contracted.

That the heart should go on beating after removal from the body does not seem greatly surprising, because it is still then alive. The wonder lies rather in its continuing to live so long when thus removed; that granted, it seems natural that it should do what it has done previously all its life.

But this other muscle, which likewise continues to live when removed from the body; it, though it can contract,

does not. That seems—at least at first sight—the more remarkable. Why does this muscle stop? So long as it was part of the living creature it showed contraction over and over again. We must turn to the nervous system for our answer.

In the first place let us note that an animal, unlike that other great example of life, a plant, cannot nourish itself from naked earth and air alone. The plant strikes down roots and throws up leaves, and draws through these material and energy with which it can replenish its own substance and activities. Where it as a seed fell, there its foster-mother Earth gives it the food it wants. Not so the animal. It must have subtler and rarer stuffs, or die. The material it needs is not spread so broadcast. It, to replenish itself, must have more special material; it must have for food material that is living, or has lived. To obtain this it has to range about. It has to hunt for it; and it itself is hunted by other animals following the same quest. Therefore its very existence involves locomotion. It must find food and seize it, and must itself escape being found and seized. It is both hunter and hunted. Moreover, in a vast number of cases it has to seek its kind to propagate its species. The movement necessary in this great game of life is million-sided—subtle beyond words—and most animal lives are spent in nothing else. Existence for the individual and the race depends upon success in it. Man plays it also—let us hope that sometimes he plays something else as well. In all cases the chief instruments of the game are the skeletal muscles, those muscles of which the biceps of our arm may stand as type. An old philosophic adage has it that all which mankind can effect is to move things. The dictum illustrates how supremely chief an executant of man's activity his muscles are. All the things which man can move are moved in the first instance by that prime thing which he can move, his body; and for this his main agents are his skeletal muscles. These execute his movements, but in doing so are but the instruments of his nervous system. Therefore it is in reality the nervous system which is the player of the game; and it is because it is really the nervous system which is the player of the game that man is the most successful creature on earth's surface at the present epoch, for his is the nervous system which, on the whole, is the most developed, much best adapted to dominate the environment.

To understand a little how the nervous system compasses this end we may turn to examine its performance in some of its simpler governing of the muscles. Its main office is to react to changes in the environment. The animal body is provided with a number of organs specially attuned to react to changes in the environment. These changes, in so far as they excite these organs, are termed stimuli. Thus, it has organs stimulated by the radiant energy of light and heat, others by chemical particles drifting from odorous objects, others mechanically by objects touching the skin, and so on. These organs, specially adapted to environmental stimuli, are called receptors. Attached to them are nerves. Through these the excitement set up in the receptor by a stimulus spreads to the general nervous system. Arrived there, two kinds of effect ensue from it—one, a change in nerve-cells innervating muscles and glands, the other, a change in consciousness on the basis of sensation. These two effects are separable. The former, or "reflex" reaction, is not necessarily accompanied by any manifestation of the latter, though it may be so, and very often is so. We will confine ourselves to the former, or purely reflex effect, and to its operation on muscle.

The endowment with receptor organs is not equally rich in all parts of the body. It is the external surface of the animal which, as we might expect, has them in richest profusion; and the receptors of the external surface are likewise those most developed, specialised, and sensitive. This also we might expect; for it is the external surface that for countless ages has felt the influences of the illimitable outside world playing on it. Through refinement of the receptors of its outer surface the animal has been rendered sensitive in many cases to stimuli delivered even by the remotest stars.

It is a feature of receptors generally that they react most to their agent when the intensity of that agent

changes, and the more so the more abrupt the change. It is, therefore, changes in the outside world that operate especially as stimuli, though, of course, only changes which have relation to the animal in question. If we regard the mutual relation between the animal and the world at any moment as an equilibrium, then we can say that any change in the world which changes that relation disturbs the equilibrium.

Take the instance of a child asleep. A thousand agencies of the external world are playing upon it. Upon its skin, for instance, there is the pressure of the child's own weight against the receptors, and there is the pressure of the clothes which cover it; yet it lies restful. Suppose we touch its foot. That is a change in the external world in relation to the child. The familiar fact is that the foot is drawn up out of harm's way, as it were. The change has acted upon the child as a stimulus to some receptors of the skin. It may be quite unconscious of the touch, for its sleep may be deep. Yet the reflex action has occurred, and has done the appropriate thing. A candle may be brought into the room and its light reach the face of the child. That is a change in the outside world in relation to the child. The familiar fact is that the child's head turns from the light. It sees no light, but reflex action averts its face. Or, turning to other forms of life, take a fish quiet in its aquarium. A worm is dropped into the water, and the disturbance of the water reaches the surface of the fish. The fish turns and seizes the morsel. Such a reaction on the part of such a creature is probably wholly reflex.

The point for us here is, that the changes in the outside world which act as stimuli bring about appropriate re-adjustments of the body to the external world, and that in doing so the instruments of readjustment are the skeletal muscles, worked by the nervous system. The child's heart goes on beating, whether the child's foot lies quiet or is moved, whether its face lies this way or lies that; the fish's heart whether the animal's skin was stimulated by fresh commotion in the water, or was not. But with the skeletal muscles it was different. Flexor muscles of the leg, that were relaxed, are by the touch to the foot thrown into action; muscles which lay relaxed were, when the light came, caused to contract, turning the head away. Muscles of the fish that were inactive were thrown into activity by the new commotion in the water. It is these skeletal muscles, therefore, that the daily thousand changes of the external world so repeatedly and constantly affect in this way or that, and in reflex action it is always the receptors and the nervous system which impel them to react; and the result is to re-adjust advantageously to the animal its relation to the altering external world. Hence these muscles are called the muscles of *external relation*. So prominent are these muscles in the everyday work of life that they are the muscles of ordinary parlance. The man in the street is hardly aware that he has in his body any other muscles. These muscles are, through the nervous system, driven by the external world. The world outside drives them by acting on the receptors. It is not surprising, therefore, that this little muscle, removed from the body, and therefore separated from the nervous system and all its receptors, remains, although still living and able to contract, as functionally inactive—for contraction is its function, and it does not contract—as if it were already dead.

Now this muscle, when in the body, was the servant of a thousand masters. It had to contribute to a thousand acts. In a certain sense, it, like the heart, had to do for them all but one thing, inasmuch as it had to pull the limb in one certain direction; and yet its task is a very varied one. It has to pull the limb sometimes far, sometimes very slightly, or through all intermediate grades. It has to pull it strongly against great resistance, or weakly, and with all intermediate grades of intensity. We may suppose that in the course of evolution it had become adapted to this scope of purpose.

And indeed we find it so. Unlike the heart muscle, this muscle when a strong stimulus is applied contracts strongly, when a weak stimulus, weakly; under a long stimulus it contracts long, under a brief, briefly. The nervous system, in making use of this muscle, wants of it just such varied action as this—now weak, now strong,

now brief, now long, as may be suited to the act required. The little organ is admirably adapted to be the animal's instrument in the world in which it is placed. This muscle has its place in the economy of nature, and into it it fits as a key into the lock for which it has been made. Man's naive view, until somewhat recently, was that the earth and the universe were made to fit him. Was the universe made to suit this little muscle or was this little muscle made to suit the universe? The problem concerning this muscle and that concerning man are, in so far, the same. Surely our answer is that the muscle and the rest of the universe fit each other because they have grown up together—because they are part of one great whole; they fit just as a lock and key fit because they compose one thing, and it is pointless to ask whether the lock was made to fit the key or the key the lock.

The office of the nervous system is to coordinate the activities of the various organs of the body, so that by harmonious arrangement the power and delicacy of the animal's mechanism may be obtained to the full. When reflex action withdraws the foot of a sleeping child, it is not merely one such muscle as this which moves the limb, but many. The limb has many muscles, and even in such a simple act many and many of them are employed.

That the act occurs during sleep shows that consciousness is not its necessary adjunct. A similar act can be similarly evoked in an animal when the brain—the seat of consciousness—has been removed. The brain can be removed under deep narcosis of chloroform without any pain or feeling whatsoever. After that removal the animal is no longer a sentient or conscious thing at all. Then we can study in it the power of reflex action sundered from conscient and sentient life altogether. Then it is that opportunity is given for further reverent analysis of those wonderful and subtle workings of the nervous system which in ourselves are so difficult to unravel for the very reason that their working goes on without appeal to, and often beyond access of, the conscious self.

When analysing the muscular action of even so simple a reflex act as that of drawing up the foot, a fact which early meets the observer is that the nervous system treats whole groups of muscles as single mechanisms. In lifting the limb it employs together muscles, not only of one joint of the limb, but of all the joints—knee, hip, ankle, &c. It deals with all these muscles as if they were but one single machine. If the movement is forcible, it throws them all into strong contraction; if weak, into weak. In the grading of the reflex action its influence is graded in all these muscles alike. So also the contraction in all of them is timed to begin together, to culminate together, and to desist together. Further, although the movement of this lifting of the limb is mainly flexion at its joints, the reflex accomplishes along with that some internal rotation of the hip and some abduction of the thigh. Why it should do so we shall see presently. Suffice us for the present that, besides the flexor muscles, the nervous system brings into play, at the same time and harmoniously with those, two other great groups of muscles, the internal rotators and the abductors. So perfect is its skill in using the muscles as its instruments that it can deal harmoniously and simultaneously with all these individually complex groups of motor organs as though they were but one.

Were we to attempt to produce this movement in the limb experimentally without employing its nervous system, we should have to apply I know not how many stimuli simultaneously to more than half the muscles of the limb. Not only that, but we should have to grade the stimulation of each of these most accurately to a particular strength. We should also have to arrange that, not only did each stimulus develop its full strength with the right speed, but that each should maintain it for the appropriate time and desist at the right speed and moment, and with proportioned intensity. Moreover, in the real reflex act the contraction of this or that muscle is now stressed, now subdued, with a delicacy and accuracy baffling all experimental imitation. The coordination in even the simple reflex we are considering may be likened to that exhibited by a vast assemblage of instruments in very perfect orchestration directed by a supremely capable conductor.

But it is more subtle and delicate than that, even in

the simple reflex we are considering. The coordination goes much farther than we have yet assumed. The musculature of the limb is an instance of that kind of musculature which obtains where parts are adapted to move, not in one direction only or one way only, but in many. The limb has to do many different things. It has, according to circumstances, to bend or to straighten, to turn inwards at one time, at another to turn outwards, to move this finger or move that. Its musculature is therefore split up into many different muscles—some doing this, some doing that. Hence it comes that in the limb are muscles which when they contract do with the limb exactly opposite things. Thus we find a set of muscles which bend the knee, and another which straighten the knee; so, similarly, at hip and ankle, at elbow, shoulder, and wrist. These muscles of opposed action are called antagonists. Now in the flexion reflex—the reflex we are considering—when the reflex bends the knee by causing the flexor muscles to contract, what happens with regard to the muscles which straighten the knee? Do the opponents, the muscles which straighten the knee, contract, or does the reflex nervous influence leave these muscles untouched? It used to be taught that the muscles which straighten the knee, the extensor muscles, contract, and by their contraction exert a moderating influence on the muscles which execute the flexion. That was the anatomical speculation deduced from simple dissection of the musculature of the dead limb. Experiment with the living limb teaches that nature does not expend her muscular energy in using the power of one muscle simply to curb the power of another. When the knee is bent the reflex act does not hamper the working of the flexor muscles by causing a contraction of the extensors also. Nor does it simply leave the extensors out of account. No; it causes them to relax and lengthen at the same time as it causes the flexor muscles to contract and shorten. This it does by reflex inhibition; and it proportions the grade of this relaxation exactly to the grade of contraction of the opponent muscles.

The inhibition acts, not on the muscle directly, but on the motor nerve-cells innervating the muscle. These nerve-cells are long filaments; one end of each lies in the muscle, the other in the spinal cord. The reflex inhibition is exercised upon them at the end which lies in the spinal cord. In the reflex we are considering, the reflex action, besides exciting the motor nerve-cells of the three muscle groups—flexors, abductors, and internal rotators—before mentioned, inhibits the motor nerve-cells of three muscle groups antagonistic to those, namely, the extensors, the abductors, and external rotators. We see, therefore, that in even the simple reflex lifting of the foot, almost every one of the many muscles composing the whole musculature of the limb receives from the nervous system a controlling influence, either of excitation to contract or of inhibition which relaxes contraction; and all this in result of a simple touch of the skin of the foot. The reaction typifies in a simple manner the action of the nervous system to knit the heterogeneous powers of the body together into one harmonious whole.

Thus we see that in these actions when one group of muscles contracts the group antagonistic to it relaxes. This is a fundamental part of the coordination of the act, and its discovery throws a welcome light on the nature of certain maladies. Were the antagonistic group to contract at the same time as the protagonist, the desired movement would not result. The movement which then ensued would depend on which of the two muscle groups were the stronger, the protagonist or the antagonist. The alkaloid strychnine and the poison produced by the bacilli which cause the malady called "lock-jaw" possess the nature of destroying reflex inhibition. What the intricate nature of the process of this inhibition is we do not yet know, but it seems to be the exact converse of the process of excitation, the nature of which is also unknown. Strychnine and tetanus-toxin change the process of inhibition into its converse, namely, excitation. If a minute quantity of strychnine be administered, the reflex which, as a rule, causes the limb to bend, now causes the limb to straighten instead. This is because the extensors, when the flexors contract, instead of being relaxed by inhibition, are excited to contraction, and being more powerful than

the flexors move the limb in exactly the opposite direction to that in which it should move in this reflex action. Similarly with the toxin of "lock-jaw." The muscles which close the jaws are much more powerful than those which open them. In the normal act of opening the mouth the relatively feeble opening muscles contract, and the powerful closing muscles are simultaneously relaxed by reflex inhibition. But in an animal or man poisoned with this toxin the normal inhibition of the closing muscles is changed to the exactly opposite process of excitation, so that their contraction results. Against the power of these strong closing muscles the contraction of the weak opening muscles can effect little. Each time, therefore, that the sufferer tries to open his jaws to take food or speak, he clenches his jaws instead of opening them—experiencing a torture which, although unaccompanied by physical pain, is inexpressibly distressing; and the disorder leads to death from inanition.

But to return to the reflex lifting of the leg, whence we set out. It was mentioned that in this reflex the limb was not merely lifted, but was slightly rotated inwards at the hip, and that the thigh was slightly abducted, that is to say, drawn sideways, separating it more from the fellow-limb of the opposite. These accessory movements have a significance coinciding with much other evidence into which we have not time to enter now. They, together with other evidence, show that this lifting of the leg, so easily produced reflexly, is nothing more nor less than the first movement of the taking of a step. In fact, in our rough and imperfect analysis of this little movement, we have been examining part of the great and extraordinarily complex and perfect act which is called walking—or more technically, so as to include the cognate acts of trotting and running—locomotion. A little reflection will suffice to assure you that included in the action of locomotion is also that of standing. We are apt to forget that the muscles have a static as well as a kinetic action—that they are the instruments of maintaining position, as well as of the execution of movements. Directly we begin to analyse locomotion we see that its basis, as it were, is the position of standing, upon which movements of stepping are, as it were, grafted. Not much is known as yet of how animals and ourselves stand, walk, and run. In these acts, probably, every skeletal muscle in the whole body is concerned. Rheumatism can make us aware of that. A little receptor organ in the ear is a great factor in the whole matter. But of this we may be sure, that foremost in its factors are reflex actions of the limbs. Great economic questions are involved in this unravelling of the act of locomotion—all beasts of draught and burden are chiefly useful to us because they can stand, and walk, and run. We can only employ their powers to full advantage and with due regard to them as they unfold these powers when we shall have learnt something of the way in which these movements are conducted and performed.

The crude and imperfect analysis which I have attempted to outline concerned but one phase of the step of a single limb. In the complete act the other limbs will at the same time be executing other phases of the whole cyclic reflex. The neck and trunk are also involved; so, likewise, the head itself. Our imperfect analysis threw sidelights on the nature of the mischief wrought by strychnine-poisoning and the malady "lock-jaw." Interesting and useful though these sidelights may be, more really interesting and valuable would be any light which such analysis, crude as it is, could throw on that great normal process of everyday health, animal (including human) locomotion. Analysis of the reflex movement in unconscious animals seems at the present time the only way by which such knowledge can be gained.

UNIVERSITY AND EDUCATIONAL INTELLIGENCE.

CAMBRIDGE.—Lord Rayleigh was on April 10 unanimously elected Chancellor of the University in succession to the late Duke of Devonshire. It is expected that the inauguration and the installation of the new Chancellor will take place during the May term.

EDINBURGH.—At the spring graduation ceremony on April 10, the honorary degree of Doctor of Laws was conferred upon several guests in recognition of scientific work. Sir Ludovic Grant, dean of the faculty of law, in presenting these recipients of the degree, made the following references to their achievements in the field of science:—

DR. J. O. AFFLECK.—Whether regard be had to Dr. Affleck's work as a teacher, or to his scientific contributions to medical literature, or to his eminence as a physician and his services in the practice of his profession, he is equally deserving of recognition at the hands of his old Alma Mater. Almost from the time that he graduated, Dr. Affleck has been an indefatigable writer. Indeed, the great bulk of the medical articles in the ninth edition of the "Encyclopædia Britannica" are from his pen. These, and his other papers, form together a veritable storehouse of scientific information.

DR. RICHARD CATON, Lord Mayor of Liverpool.—Dr. Caton was one of the band of devoted labourers whose strenuous exertions were instrumental in calling into existence the University of Liverpool, and he himself discharged the duties of professor of physiology for many years with conspicuous success. With his scientific attainments Dr. Caton combines the accomplishments of the scholar and the zest of the archaeologist. His lectures—embodying the fruits of visits to Greece and the Greek colonies—on the Greek and Egyptian gods of medicine throw a flood of light on the medical and sanitary aspects of the ancient world.

SIR NORMAN LOCKYER, K.C.B., F.R.S.—The fairy-book of science contains no more fascinating and marvellous pages than those contributed by the illustrious astronomer whose name has been so long a household word amongst us. It is to his spectroscopic researches that the present generation is largely indebted for its knowledge of the material constituents of the sun and of the stars. He it is who, simultaneously with the French astronomer Janssen, devised a means of studying the luminous atmosphere surrounding the sun, and those gigantic flames which previously could only be observed in the brief moments of a solar eclipse. He it is who first detected helium in the sun before this element had been discovered on the earth, while his investigations into the sun's spots and corona are of the highest importance in solar physics. It is worthy of mention that he has acted as the leader of more eclipse expeditions than any contemporary astronomer. The stars, too, have yielded to him their secrets not less obediently than the sun. By means of the comparative study of stellar spectra, he has drawn up a classification of the celestial bodies according to their temperatures and the order of their evolution, which must be reckoned as not the least noteworthy of the achievements of modern science. The great subject of "orientation" has also engaged Sir Norman Lockyer's attention. He has examined the monuments at Stonehenge and elsewhere, in their relation to astronomical phenomena, a work which is of great value as serving to fix the dates of their erection. The cause of scientific education generally has had no more ardent and eloquent advocate than Sir Norman Lockyer, and, as editor of NATURE and as founder of the British Science Guild, he has done as much as any man living for the diffusion throughout the country of the scientific spirit. The University is sensible that it is doing honour to itself in adding Sir Norman Lockyer's name to its roll of honorary graduates.

M. E. C. M. SENART, Chevalier de la Légion d'Honneur, Membre de l'Institut, Paris.—The literature of ancient India has been handed in modern Europe by no scholar of more exclusive erudition or more splendid attainments than by M. Senart. He first attracted the attention of the learned world by the publication, some thirty years ago, of his "Essay on the Legend of Buddha." Then followed the volumes on the "Inscriptions of Asoka," and a highly popular and instructive work on the Indian castes. Of his subsequent writings, none better exemplifies the remarkable range and accuracy of his scholarship than his edition of the famous Kharosthi MS. of the Dhammapada, which was recovered from Central Asia by a French mission, while his monumental translation of the Mahavastu is sufficient by itself to place him in the highest

rank of philologists. His long series of publications, viewed as a whole, possess an importance which cannot easily be exaggerated, alike from the point of view of history, of philology, and of archaeology. M. Senart's achievements have received honorary recognition throughout the civilised world, and it is gratifying to relate that his influence has been instrumental in raising up in France a distinguished school of Orientalists, who, it may be hoped, will continue to carry on his work.

The degree was also conferred *in absentia* on RAMKRISHNA GOPAL BHANDARKAR, C.I.E., lately professor of Oriental languages, Deccan College, Poona. Prof. Bhandarkar is famed as a Sanskritist throughout the length and breadth of British India. His learned labours have extended over many years, and have been productive of a rich and valuable harvest of exegetical editions of Sanskrit works. These are chiefly remarkable in that they exhibit all that is best in the methods of interpretation traditional in India in combination with the critical scholarship of modern times. Prof. Bhandarkar has also devoted himself to the study of history and antiquities. He is the author of an admirable "History of the Deccan" and of numerous archaeological essays.

MANCHESTER.—The University kite station at Glossop Moor has now been equipped with a plant for the generation of hydrogen gas for use in work with captive and free balloons. Captain Ley has taken up residence on the moor in order to continue and extend his investigations for the study of the higher air currents by means of free balloons.

Is the new Ministry formed by Mr. Asquith in consequence of the retirement of Sir Henry Campbell-Bannerman from the office of Prime Minister, Mr. W. Runciman has succeeded Mr. R. McKenna as President of the Board of Education, and Mr. McKinnon Wood has succeeded Mr. T. Lough as Parliamentary Secretary to the Board.

To the April number of *Science Progress* Prof. H. E. Armstrong contributes a vigorous article on the reform of the medical curriculum, in which he replies to Dr. Wade's remarks on a previous paper dealing with the same subject. The article covers a wide field, and is by no means confined to the question of medical education, as it deals with the broader issue of university education in general. In particular, the position of affairs within the University of London—the opposition existing between the external graduates and the internal schools, which has culminated in the formation of two representative bodies, the Graduates' Union and the Graduates' Association—calls for comment. A strong plea is urged for extending the internal system so as to allow each of the larger colleges to organise its own scheme of education for the final degrees according to the particular work it has to accomplish, without being hampered by external control through examination. Such a scheme is considered as by no means likely to lower the standard of the degree, but to tend in the opposite direction by making the education imparted more real and effective.

SIR WILLIAM H. PREECE, K.C.B., F.R.S., read a paper on technical education in America before the Royal Society of Arts on April 8. Referring to the munificent gifts made by American millionaires to assist educational development in the States, he directed attention to the fact that the distribution of wealth is such a matter of fashion. In 1906, in London alone more than ten millions sterling were bequeathed for various purposes, but of this only 123,778*l.* was allocated to education. The total amount bequeathed over the whole country must have exceeded fifty millions sterling, and of this probably only 1 per cent. was devoted to education. Speaking of American employers of industry, it was pointed out in the paper that they fully recognise the advantage of technical attainments in their employees, they encourage research, they equip their own laboratories, and they support college and university by financial help, and by the gift of machinery. In America, said Sir William Preece towards the close of his remarks, all are working on fixed methodical lines, and gradually a national coordinated system will be evolved which will make the United States

the best secularly educated country in the world, and their education policy thoroughly organised.

AN interesting comparison of examination statistics in 1906 with those in 1899 is made by Mr. G. F. Daniell in *The School World* for April. Dealing with the results of the matriculation examination of the London University, the article shows that, whereas in 1899, out of 1250 candidates, 842 selected a language and 402 a science "option," 3140 chose a linguistic and 2962 a scientific subject out of a total of 3253 in 1906. In the senior local examinations held by the Cambridge University, the stunted condition of the scientific side shown by the 1899 statistics gives place in 1906 to a more reasonable balance of science and the humanities, and, in the aggregate, the statistics of the junior examination show that science subjects are now receiving fair attention in secondary schools in general. Apparently, however, this cannot be said of the great public schools. Referring to the statistics published by the Oxford and Cambridge Schools' Examination Board, which examines pupils from public and high schools, Mr. Daniell remarks that out of 1027 candidates for the lower certificate of this Board, a total of thirty-four passes in the first class was obtained in the science subjects—of these thirty-four, no fewer than half were in botany, the successful candidates being mostly girls. Among some 2200 candidates for the higher certificate, eighty-three distinctions were obtained in science. It is justly pointed out that "this grudging admission of the claims of experimental science does not satisfy anyone who has realised the importance of educating the nation, especially the upper and middle classes, so that the future may find us not wanting in men of scientific intelligence."

SOCIETIES AND ACADEMIES.

LONDON.

Royal Society, February 14, 1907.—"The Thermomagnetic Analysis of Meteoric and Artificial Nickel-Iron Alloys." By S. W. J. Smith. Communicated by Sir A. W. Rücker, F.R.S.

As the result of purely magnetic researches, the author comes to the conclusion that a typical octahedral meteorite (containing about 7 per cent. Ni and about 93 per cent. Fe, and exhibiting very regular Widmanstätten figures) consists mainly of an alloy of the two constituents containing about 63 per cent. Ni. This alloy is kamacite. The thin intervening bands of more nickeliferous material (taenite) are shown in the same way to contain about 27 per cent. Ni, but, further, to be a mixture of nickel-richer and nickel-poorer constituents.

The view most commonly accepted hitherto, as the result of many careful chemical analyses, has been that taenite contains at least 36 per cent. Ni. A critical examination of these analyses shows, however, that they are in accord with the more certain conclusion derived from thermomagnetic data.

In the investigation of a problem of this kind chemical methods lead to ambiguous results, because it is impossible to isolate (from a material like meteoric iron) the secondary constituent (taenite) chemically without fear of partial solution. On the other hand, the taenite can be studied *in situ* by means of the change of its magnetic properties with temperature, because these properties vary in a markedly different way from those of the main constituent kamacite. Thus it can be shown that its properties correspond with those of the artificial 27 per cent. alloy, just as those of the kamacite correspond with those of the artificial 63 per cent. alloy.

The inference from the experiments that taenite is a eutectic mixture (of coarser structure originally than the artificial 27 per cent. alloy, which is proved also to be a mixture) is shown to be in accord with all that is known concerning nickel-iron alloys, and to afford an adequate conception of the way in which the characteristic structure of meteoric iron has arisen.

The behaviour of "irreversible" nickel-iron alloys during changes of temperature is shown also to be closely

analogous to the behaviour of the metastable and labile fluid solutions studied by Prof. Miers.

An explanation is given of the important fact that an artificial nickel-iron alloy containing about 27 per cent. Ni is a "magnetic invar," of which the magnetic quality remains practically constant over a range of about 300° C. after the alloy has been cooled to the temperature of liquid air.

Further development of the thermomagnetic method is to be looked for in cases in which chemical and micrographic methods either fail to remove ambiguity or are inapplicable; meanwhile, if the interpretation of the thermomagnetic data considered is held to be established, a good many doubtful points in the relationship between iron and nickel in their alloys have been made clear.

January 23, 1908.—"Dietetics in Tuberculosis: Principles and Economics." By Dr. N. D. Bardswell and J. E. Chapman. Communicated by Sir T. Clifford Allbutt, K.C.B., F.R.S.

February 13.—"The Decomposition of Ozone by Heat." By Prof. E. P. Perman and R. H. Graves. Communicated by Principal E. H. Griffiths, F.R.S.

The rate of decomposition of ozone has been measured under various conditions, with the following results:—

(1) In a glass vessel the reaction is approximately of the second order.

(2) The relation between the rate of decomposition and temperature may be expressed by the formula $\log k = a + bt$.

(3) The rate of decomposition is very largely influenced by the extent of the surface with which the ozone is in contact.

(4) The reaction is of the first order when the ozone is in contact with a porous substance (clay-pipe stems) or some oxides.

(5) Metallic surfaces have but little effect on the decomposition.

(6) Water vapour accelerates the decomposition, and the acceleration is proportional to the amount present.

(7) Nitric oxide greatly accelerates the decomposition.

(8) The rate of decomposition is a linear function of the oxygen pressure. A greater effect is produced by diluting with nitrogen than by simply reducing the pressure of the oxygen.

(9) At 100° the reaction appears to be very slightly reversible.

(10) Finally, the decomposition appears to take place mainly (if not entirely) at the surfaces with which the ozone is in contact, and pressure measurements give no indication of the number of molecules reacting.

Mineralogical Society, March 17.—Prof. H. A. Miers, F.R.S., president, in the chair.—The occurrence of metamorphic minerals in calcareous rocks in the Bodmin and Camelford areas: G. Barrow and H. H. Thomas. The pneumatolytic action is not contemporaneous with the thermo-metamorphism produced by granite intrusions; the gaseous intrusions are later, and often produce their greatest effect beyond the zone of "contact action." The species of mineral produced depends on the nature of the rock penetrated by the gases. In Killas, tourmaline is commonly produced, but in calcareous rocks, axinite and a variety of other minerals result from the pneumatolysis. In the Bodmin area the minerals formed by pneumatolytic action in the calc-flintas are axinite, hedenbergite, epidote, yellow garnet, actinolite, and another amphibole occurring in minute dark-brown needles. In the Camelford area the minerals are mainly due to contact metamorphism. The most conspicuous are yellow garnet, epidote, and idocrase, a mineral which has not hitherto been recorded from Cornwall.—A protractor for use in constructing stereographic and gnomonic projections: A. Hutchinson. A short historical account was given of the stereographic projection, and a protractor designed to facilitate its construction was shown. By the aid of this protractor the radii of both great circles and small circles can be readily determined. It can also be applied to the construction of the gnomonic projection, and to measuring the angles between planes and zones.—Supplementary notes on the

mineral kaolinite: A. B. **Dick**. Further observations on the optical characters of kaolinite from Anglesea lead to some alterations in the data given in a previous paper. The refractive index is about 1.563 for sodium light, and the optic axial angle, $2V$, is about 68° instead of 90° . The double refraction is very low. Kaolinite from limestone at Hambleton Quarry, Bolton Abbey, Yorkshire, and from sandstone near Newcastle-on-Tyne were described.—An attachment to the goniometer for the measurement of complex lamellated crystals: H. L. **Bowman**. The apparatus, consisting of a small screen pierced by a pin-hole, can be attached to a goniometer, and is capable of adjustment so that minute portions of a crystal face can be successively illuminated.—A new form of quartz-wedge, a modification of the Wright-wedge: J. W. **Evans**. A quartz-wedge cut parallel to c is placed over a gypsum-plate parallel to a showing red of the first order, and extending beyond the thin end of the wedge, so that the projecting portions can be used as an ordinary gypsum-plate. The region where the wedge overlies the gypsum is graduated at the position of exact compensation, and at each thousand micromillimetres of relative retardation. If, when placed over a mineral in the diagonal position, the black band is moved towards the thin end of the wedge, the direction of insertion is that of the vibrations which traverse the mineral with the smaller velocity; if towards the thick end, the direction is that corresponding to the greater velocity.—Calculation of the chance that the double refraction of a crystal section cut at random shall exceed a particular fraction of the maximum: H. **Hilton**. The problem is soluble completely for a uniaxial, and partially for a biaxial, crystal.

Physical Society, March 27.—Dr. Charles Chree, F.R.S., president, in the chair.—Notes on the plug permeameter: Dr. C. V. **Drysdale**. In the instrument a drill is employed to cut a conical hole in a casting or forging, leaving a pin one-tenth inch diameter standing in the middle. A wrought-iron plug carrying a bobbin with magnetising and search coils completes the magnetic circuit, forming a miniature permeameter. Investigations have been made showing that the amount of the end effect can be compensated by correcting the value of H in the same ratio for all specimens. Curves were given showing the results obtained by the plug permeameter when the instrument had been empirically calibrated.—The use of shunts and transformers with alternate current measuring instruments: Dr. C. V. **Drysdale**. The paper deals mathematically and experimentally with errors in the magnitude and phase of the current. With shunts, the condition for accuracy at all frequencies is that the time constants of the instrument and shunt should be equal. For current transformers the best results are obtained by keeping the magnetising and core-loss currents as small as possible.—Dynamometer wattmeters: Dr. C. V. **Drysdale**. An investigation of the theory of the wattmeter, including the effects of shunt inductance and capacity, mutual inductance, eddy currents, wave-form and of iron. It is pointed out that the theory of the wattmeter is much obscured by the use of the correction factor. The correction of a wattmeter should be applied as a difference, and not as a ratio. A description of single and double forms of standard wattmeter and of deflectional wattmeters containing iron was given.

Institution of Mining and Metallurgy, April 9.—Mr. Bedford McNeill, vice-president, in the chair.—The electrical equipment of gold mines: H. J. S. **Heather**. A review of the present application and future possibilities of the application of electric power to mining operations, with practical notes of installations that have been made under the author's supervision. He points out the relative advantages or otherwise of the continuous and alternating current systems for the purposes of gold-mining work.—Addendum to paper on earth temperatures on Witwatersrand gold fields: Hugh F. **Marriott**. A matter dealt with in a previous paper by the same author centred round the mean earth temperatures at the surface in the vicinity of the Rand. This addendum records subsequent investigations tending to settle the point in dispute in connection with the attempt to establish a rule for the average increase of temperature with depth.—The carat weight:

E. J. **Valentine**. A concise account of the origin and present position of the carat weight as used by dealers in gold and precious stones, with records of the steps taken to establish a standard metric carat for universal adoption.—An electromagnet for testing the suitability of an ore for magnetic separation: L. H. L. **Huddart**. A description of a hand apparatus designed by the author for use abroad. It is suitable for the quantitative determination of the separation to be expected in treating a given ore by means of a powerful magnet.—The gold alluvials of the river Drau in Hungary: A. von **Gernet**. A brief account of the subject of the title, with comparisons of the relative efficacy for determining values obtained by panning small samples and counting "colours."

Royal Astronomical Society, April 10.—Mr. H. F. Newall, F.R.S., president, in the chair.—Description of a 24-inch long-focus cœlostast reflector: J. H. **Reynolds**. The instrument has been constructed for use in spectro-heliographic work, but is also arranged for taking celestial photographs. The focal length is 38 feet, and the diameter of the plane mirror of the cœlostast 28 inches. Specimens of photographs taken with the instrument were shown on the screen.—Dr. A. W. Roberts's method of determining the absolute dimensions of an Algol variable star: Rev. J. **Stein**. Dr. Roberts had attempted to deduce from the light curve of such a variable the dimensions of the orbits of its components, but Mr. Stein showed that it is theoretically impossible to determine the absolute dimensions of the orbit in this manner.—Note on the newly discovered eighth satellite of Jupiter: **Astronomer Royal**. The moving object near Jupiter, found by Mr. Melotte upon photographs taken at the Royal Observatory, had been again photographed on March 27, 31, and April 3. It had also been photographed by Dr. Max Wolf at Heidelberg and at the Lick Observatory. It now appeared that the new object is a satellite of Jupiter, much more distant from the planet than the sixth or seventh satellites.—First approximation to the orbit of J. VIII.: A. C. D. **Crommelin**. The hypothesis of retrograde motion for the new satellite appeared at present most probable; from the preliminary elements obtained the sidereal period would probably be between three and four years, and the distance from the planet about three times that of Satellite VII.—Variable-star work at Rousdon Observatory: C. **Grover**.—A new "spanner" sextant: Captain **Gadsden**. The arrangement consisted of an attachment to a sextant to enable observations to be made when the horizon is obscured or hazy.—Note on the conditions for the passage of the earth through the plane of Saturn's ring: H. H. **Turner**. The late Mr. Proctor had given a general account of the manner in which the earth may pass through the plane of the ring, either once or three times at each favourable opportunity. The present paper gives the explanation in a more compact and complete form.—Retrogradation of the sun's shadow: M. E. J. **Gheury**.—Series of photographs of the Milky Way taken with a small lens of $5\frac{1}{2}$ inches focal length: Dr. Max **Wolf**.—Experiment illustrating the gradually increasing red colour of the sun as it approaches the horizon at sunset: S. L. **Fletcher**.

PARIS.

Academy of Sciences, April 6.—M. H. Becquerel in the chair.—An isomer of diphenylcamphomethane and the conditions of its formation: A. **Hailer** and E. **Bauer**. Details are given of the best method of reducing

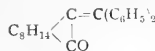

in alkaline solution. The substance obtained, diphenylcamphomethane, is isomeric with the substance obtained by carrying out the reduction in acid solution, and can be obtained from the latter by boiling with alcoholic potash, and in other ways. Various attempts have been made to elucidate the constitutions of these two isomers, but hitherto without success.—A new mineral species from the French Congo: A. **Lacroix**. The new mineral is a silicate of copper, differing from diopside in being attacked with difficulty by acids, and in its composition,



The name *planchette* is proposed for the mineral.—The perception of relief and of depth in the simple image of ordinary photographs. Conditions and theory of this perception: A. **Chauveau**. By a suitable adjustment of the prisms of a stereoscope, the effect of relief can be obtained from a single photograph just as well as if the latter were replaced by the usual double stereoscopic photograph. The effect can be produced without any apparatus; the examination with one eye alone of a well-lighted photograph after some time causes the stereoscopic effect. To reduce this to the usual plane effect the other eye is required. The theory of these phenomena is considered in detail.—The acceleration and retardation of the coagulation of the blood in capillary tubes: Ch. **Bouchard**.—The Coal-measures of the southern Oran: H. **Douvillé** and M. **Zeiller**. A detailed description of the fossils met with is given, and the analogy with the Carboniferous deposits in England pointed out. This is the first time that a Westphalian flora has been discovered in such a low latitude.—The subgroups of the homogeneous linear group of four variables, and the systems of partial differential equations which correspond to them: M. **Le Vasseur**. The persistent conjugate networks comprising a family of minimum lines: L. **Raffy**.—The maximum useful weight that can be raised by an aeroplane: M. **Girardville**. It is shown that the maximum useful weight carried by an aeroplane depends upon five variables, and possibilities of improvement may be sought for in modifying each of these.—The conditions of utilisation of balloons capable of being steered, as existing at present: M. **Bouttiaux**. An account of modifications introduced with the view of economising ballast.—The spectroscopic study of flame of various kinds: G. A. **Hemslach** and C. **de Watteville**. The method of feeding a flame with particles of metal obtained electrically, described in an earlier paper, has been applied to flames of hydrogen alone, coal gas and oxygen, hydrogen and air, and hydrogen and oxygen. Details of the results obtained with the pure hydrogen flame are given in the present communication.—The presence of spark lines in the arc spectrum: Ch. **Fabry** and H. **Buisson**. All the spark lines (the enhanced lines of Lockyer) are emitted in the arc spectrum of iron, but only by certain portions of the arc. Similar effects have been obtained with nickel and copper.—A new method of estimating the vapour of mercury in air: P. **Ménier**. The air is aspirated through boiling nitric acid in a special apparatus figured, and the minute proportions of nitrate of mercury treated with diphenylcarbazide. This gives distinctive colours in proportions of mercury varying from 1/100,000 to 1/5,000,000. The paper is accompanied by a plate showing three gradations of tint obtainable.—The combustion by incandescence of gases in presence of oxidisable and incombustible bodies: Jean **Meunier**.—The variations of composition of ammonium phosphomolybdate: application to the estimation of phosphorus in iron and steel: G. **Chesneau**. The author regards a double precipitation as absolutely necessary if the precipitate is to have a constant composition, and gives detailed instructions for carrying out the process.—The ammoniacal chlorides of dimercuriammonium: H. **Gaudechon**.—Arbutine and some of its derivatives considered from the point of view of their rotatory power and their hydrolysis by emulsin: Em. **Bourquelot** and H. **Hérissey**.—Comparative study of the dehydration of atrolactic and β -methoxyatrolactic acids, β -Methoxyatropic and di- β -methoxyatropic acids: J. **Bougault**.—The formation of mixtures of isomers of constant melting point in the Friedel and Crafts reaction: G. **Perrier** and H. **Caille**. The product obtained in the preparation of phenylmethylketone by the Friedel and Crafts reaction had a definite melting point, which was unchanged after several re-crystallisations. It was shown, however, to consist of a mixture of the α and β isomers. The constitution of the membrane in diatoms: L. **Vangin**.—The action of the hygrometric state in respiratory exchanges: J. **Cluzet**.—The action of the dialytic extract of normal human urine on the arterial pressure: J. E. **Abelous** and E. **Bardier**.—The possible effects of carbon monoxide in poisoning by tobacco smoke: C. **Fleig**. The conclusion is drawn that the amounts of carbon monoxide given off during the smoking of tobacco

can contribute nothing to the effects of tobacco poisoning.—The action of brewers' yeast on the amido-acids: J. **Effront**.—Some artificial peroxydiastases: the important part played by iron in their action: J. **Wolff**.—The formation of acetaldehyde in alcoholic fermentation: E. **Kayser** and A. **Demolon**. The conclusion relating to the origin of acetaldehyde in alcoholic fermentation, described in a recent note by M. Trillat, confirms the conclusions published by the authors a year ago.—The preparation and properties of crystallised oxyhemocyanine from the snail: Ch. **Déré**.—Bile and the biliary pigments: M. **Pietter**.—The canine origin of *kala-azar*: Charles **Nicolle** and Charles **Comte**.—The rôle of positive torsion in propulsive screws and aeroplanes: P. **Amans**.—The variations of temperature of the spring of Sainte-Baume (Var): E. A. **Martel**. Another instance of the variation in temperature of springs. The spring described has on numerous previous occasions shown a temperature of 10° 5 C.; in October, 1907, after an exceptionally rainy month, the temperature rose to 13° C.

PRETORIA.

Transvaal Biological Society, January 17.—Dr. Theiler, C.M.G., in the chair.—A new species of tick found in the Transvaal: Mr. **Howard**.—Viscosity of blood: Dr. **Frei**.—Demonstration of a diseased skull of *Papio papio* (Bodd): Dr. **Cunning**.—Demonstration of some stages in the life-history of *Strongylus contortus*, Rud.: Dr. **Cough**.—Further transmission experiments with East Coast fever: Dr. **Theiler**.—(1) Some additions to the Transvaal flora; (2) new plant species from the Transvaal and Swaziland; (3) notes on drabok poisoning; (4) the application of Mendel's law of heredity in the breeding of maize: Mr. **Burt-Davy**.

CONTENTS.

PAGE

The Chemistry of the Higher Fungi. By Prof. R. Meldola, F.R.S.	553
Botanical Instruction	554
Applied Mathematics	555
Multum in Parvo. By J. A. T.	556
Our Book Shelf:—	
"Index of Archaeological Papers (1665-1890)"	557
Herrera: "Notions générales de Biologie et de Plasmogénie comparées"	558
Steinmann: "Einführung in die Paläontologie."—R. L.	558
Cain: "The Chemistry of the Diazo-compounds."—J. B. C.	558
Winkelmann: "Handbuch der Physik"	559
Letters to the Editor:—	
The Condensation of Helium.—Prof. H. Kamerlingh Onnes	559
Mendelian Characters among Shorthorns.—Prof. Karl Pearson, F.R.S.; Prof. James Wilson	559
The Nature of γ and X-Rays.—Prof. W. H. Bragg	560
The Corrosion of Iron and Steel.—Dr. Frank Clowes	560
The Geology of South Victoria Land. (Illustrated.) By Prof. J. W. Gregory, F.R.S.	561
Navigation of the Air. (Illustrated.)	562
Notes	563
Our Astronomical Column:—	
The Recently Discovered Satellite of Jupiter	567
Mutual Occultations and Eclipses of Jupiter's Satellites	567
The Transit of Mercury, November, 1907	567
Parallax Observations	567
Astronomical Photography with Portrait Lenses	567
The Harvard College Observatory	567
The Saturn Perturbations of Various Comets	568
The Games of North American Indians. (Illustrated.) By Dr. A. C. Haddon, F.R.S.	568
Nerve as a Master of Muscle. By Prof. C. S. Sherrington, F.R.S.	569
University and Educational Intelligence	572
Societies and Academies.	574

THURSDAY, APRIL 23, 1908.

A NEW CALCULUS.

1. *First Course in the Differential and Integral Calculus.* By Dr. W. F. Osgood. Pp. xv+423; with 125 figures. (New York: The Macmillan Company; London: Macmillan and Co., Ltd., 1907.) Price 10s. 6d.

THE introduction of the Calculus at an early stage in a course of elementary mathematics has rendered necessary the substitution of simplified methods of treatment for those occurring in the earlier textbooks; for example, an abandonment of the lavish and unnecessary use of infinite series, the convergency of which was generally ill-understood, in the differentiation of simple expressions.

A number of good books have recently appeared written more or less with this object in view, but we have seen none in which the survival of old and clumsy methods has been reduced to the vanishing point in the same way that has been done in this book.

The present reviewer has been in the habit of conducting a class in the calculus on simplified lines identical in nearly every respect with those adopted independently by Prof. Osgood; indeed, this book represents almost word for word what he would have wished to write had he undertaken to write a Calculus. The reviewer is thus greatly indebted to the author for having saved him this troublesome and thankless task, or the alternative of continuing the elaborate lecture notes which he has found necessary to dictate to his pupils on the bookwork of the subject. The following is a brief summary of some of the salient features of the book to which the reviewer attaches especial importance.

The methods of the calculus are discussed and exemplified in the first instance by the study of the differentiation of series of positive integral powers only. The reviewer would prefer to see the binomial theorem omitted from the proof for the derivative of x^n and a proof based on the product rule substituted, but this is a minor detail which any teacher can supply for himself and his class.

The very important method of "differentiating an equation as it stands" is explicitly used as such in finding the tangents to algebraic curves as well as in the differentiation of fractional powers, inverse functions, and the like. The introduction of this subject under the title of "differentiation of an implicit function" is quite unnecessary, and we are glad to see that the perfectly simple method really required for these cases is viewed in its right light.

In the chapter on transcendental functions the author clearly points out that the reason for measuring angles in radians is essentially explained by the calculus, and he also gives the differentiation formulæ for angles measured in degrees. The explanation is necessary in order to dispel any doubts the beginner may have previously formed as to the mental sanity of those mathematicians who deliberately chose an

incommensurable unit for the measurement of commensurable angles.

The author's introduction of the incommensurable base e , though only one of a number of different possible methods, is even more satisfactory, no previous knowledge being assumed regarding this base, which is shown to make its existence felt as soon as we attempt to differentiate a power of any constant a with respect to its index, or to differentiate the logarithm of the variable to any assumed base a .

When integration is explained the author does not waste too much time in discussing the methods of integrating long and complicated expressions, but proceeds very soon to the consideration of definite integrals and of geometrical and mechanical illustrations.

"Volumes of revolution" only constitute a particular application of a general method of finding the volume of a solid the sections of which parallel to a fixed plane are circles, squares, triangles, or other simple figures. The examples on pp. 159-161 should make this point clear.

Curvature, evolutes, properties of the cycloid, moments of inertia, and attractions are discussed at an early stage. So also are harmonic motion, resisted motion, and damped oscillations.

When infinite series are introduced the student should be ready for the satisfactory and sufficiently rigorous treatment given, especially in connection with convergence.

In dealing with Taylor's theorem, the remainder is carefully attended to, and specially mentioned in connection with the binomial theorem. We should like to have seen the remainder given as a definite integral, but this can readily be supplied in lecture notes.

Partial differentiation is fully discussed, and we notice among the examples the familiar thermodynamic application

$$\frac{dp}{dv} \frac{dv}{dt} \frac{dt}{dp} = -1.$$

There is a useful chapter on solid geometry which introduces the notion of direction cosines, the orthogonal property of confocal conicoids, and the osculating plane of twisted curves.

Double and triple integrals are well discussed. The artifices so commonly used in the older treatment for calculating volumes and centres of gravity by means of single integrations in particular cases had the disadvantage, from which Prof. Osgood's treatment is exempt, of failing to familiarise the student with notions which he necessarily encounters in the study of electricity and other branches of physics.

Hyperbolic functions are not introduced until the end. In the opinion of the reviewer they have figured far too prominently in previous treatments of the calculus, with the result that the student has been encouraged to waste time in working out integrals in complicated forms involving "sneezes" and "coughs," and "sneeze and cough minus ones," which he cannot interpret. It is to be presumed that the above words represent the most natural equivalent in speaking of the new-fashioned hyperbolic notation, for to say

"*essaitch*" and "*seaitch*" is too cumbersome. For computation integrals ought to be evaluated, as the author does, in the form of logarithms, as there are few students who, when they have obtained any result involving a "sneeze minus one," could calculate its numerical value.

We must not forget to mention the collections of examples, which are of the type approved by the most enlightened examining boards in Great Britain. They are for the most part based on practical applications, and are of such a character as to test the student's knowledge of the *calculus* itself, not his power of covering sheets of foolscap with uncomprehended formulae.

To sum up, it had become necessary to introduce considerable changes in the elementary treatment of the *calculus*, not only in the interests of the students of physics and engineering whose claims have been most prominently put forward, but also for the sounder and more rational instruction of mathematical students. The present book admirably meets the requirements of the case. We do not say that further improvements are impossible, but we consider that a stage has now been reached when any attempt to make the treatment better in one particular is very liable to render it worse in another.

May not an analogy also be suggested between the coincidence of the author's and reviewer's views, and probably the views of other teachers, and the conditions in the *calculus* for maximum value, as showing that the methods adopted are the best possible, subject to present existing conditions.

PREHISTORIC EUROPE.

L'Europe préhistorique. Principes d'Archéologie préhistorique par Sophus Müller, traduit du danois avec la collaboration de l'auteur par Emmanuel Philipot. Pp. 212. (Paris: J. Lamarre, n.d.) Price 10 francs.

THE prehistoric period in Europe is so extended, the conditions during the period so varied according to place and time, our knowledge of the conditions so meagre and broken, that the task of putting the events of the period into the form of a connected narrative is not to be lightly estimated or easily fulfilled.

Dr. Müller decides at the outset to confine himself to the consideration of matters which have received general acceptance; from this resolution he, however, soon departs, or there would have been little to tell.

The work is not so complete as the title implies; the long and important palæolithic phase is summarily dismissed at the foot of the fifteenth page. The author, moreover, has drawn his facts from one source only—that of archaeology; the evidence of craniology and philology is ignored. Nor has all the literature been consulted. In a book which deals so much with the prehistoric age of Greece it is strange to find no mention of Prof. Ridgeway and his work. Despite these defects, however, the book forms an interesting and suggestive study; it displays much thought and judgment.

The general argument, which is simple, can be expressed in a few words; it is that in prehistoric time, as in early historic time, Europe was indebted for her culture to Greece and Asia Minor; that the culture extended from the *Ægean* as a centre, undergoing more and more change as it neared the periphery. Dr. Müller likens south-east Europe, in its relation to the rest of Europe, to a town in its relation to the surrounding country. Just as the habits and culture of a town slowly spread to the rural districts, where they persist and not infrequently attain a greater development than was known in the town, so did the culture of Greece gradually extend over the whole of Europe. While on this analogy it may be well to refer to another feature—sometimes the country misses a step in the development of culture; for instance, in many districts the lamp has been directly superseded by electricity without the intermediate use of gas; so in the north of Europe the Bronze age followed on the heels of the Neolithic, whereas in the south of Europe a Copper age intervened. It will be seen that to establish his argument the author must prove that the different phases of culture appeared earlier in the south than in the north. The higher development of any phase in the north is not against the general trend of his argument. The evidence upon which he grounds his theory is obtained from art objects, polished stone weapons, articles of bronze and copper, pottery, particularly that exhibiting decorative designs, grain, domesticated animals, and the architecture of the graves.

As is well known, culture alone can prove a very misleading guide in correlating people, for where the same environment obtains, there will a similar culture tend to develop. The evidence which is at times admitted cannot be allowed to pass unchallenged. It is gravely argued, for instance, that a correlation existed between the people who lived in Spain and the Pyrenees during the Solutré period and the Iron-age inhabitants of Greece, since statuettes of similar form are forthcoming from both regions. No account is taken of the great difference in the age of the statuettes, a difference to be expressed in thousands of years.

To choose another illustration, the author finds that the polished stone celts are bigger and more numerous in the north than in the south, due to the Stone age enduring longer and attaining a higher development in the north. Moreover, in the north the stone celts are of flint, whereas in the south they are of nephrite, jadeite and chloromelanite, stones rare in Europe but more common in Asia. He thereupon argues that when Man began to polish his stone tools he would use such a soft stone as nephrite or jadeite, and would not begin to polish a stone so hard as flint until the art of polishing had made considerable advance. He therefore concludes that the nephrite celts are earlier than those of flint, and that the art of polishing extended from the south to the north. It may, however, well have been that it was the distribution of the various stones which governed the material of which the celts were made.

He takes again the spiral *motif*—in mid-Europe he

finds it on pottery, in north Europe on bronze sword-handles. In each case the *motif* is decorative, and so is found on the most highly prized objects. In mid-European pottery, so he argues, was the most valued article, bronze not yet being known when the *motif* arrived. By the time the *motif* reached the north, the Bronze age had begun.

These arguments are more ingenious than weighty; they derive their importance from the fact that they all—or nearly all—support the contention that the culture of Europe came from the south.

Dr. Müller sees no evidence of any hiatus in man's occupation of Europe. He places the end of the Palæolithic period at a date 10,000 years ago. He accepts Piette's mesolithic phase and Pigorini's conclusion that in Italy the Mousterian period passed without interruption into the Neolithic.

He discusses at considerable length the various late prehistoric periods, the Mycenaean, Dilyon, Villanova, Halstatt and la Tène. The book possesses 161 illustrations and three coloured plates; it is well printed and well planned. Its chief defect is that it is not in some respects quite up-to-date.

WILLIAM WRIGHT.

CHEMICAL RESEARCH.

Untersuchungen in der Puringruppe (1882–1906.) By Emil Fischer. Pp. viii+608. (Berlin: Julius Springer, 1907.) Price 15 marks.

ORGANIC chemistry during the last twenty years has progressed with such marvellous rapidity that it is quite impossible for the modern chemist to keep in touch with every phase of the present-day movement. The old subdivision of the investigator into the classes inorganic and organic is no longer sufficient to indicate clearly the course followed by any individual worker. Every branch of chemistry is split up into innumerable microscopic divisions, each of which claims its own adherents. Further than this, the botanist, the biologist, and others are encroaching on the domain of pure chemistry, and demand a knowledge of the compounds related to their own particular science. Bearing these facts in mind, it follows as a natural consequence that such books as the present one find so welcome a position in the standard literature of chemistry.

The present volume contains the entire experiments of E. Fischer and his students for the last twenty-four years, and deals entirely with the purine group, including the brilliant syntheses of uric acid, xanthine, caffeine, and allied compounds. The introduction, comprising the first eighty pages, appeared in the German literature in 1899 under the title of "Synthesen in der Puringruppe," and is well known to all students of chemistry. At this time the systematic study of the purine group had reached a definite issue, and since then no new principle has been evolved. The later work has been devoted to details, with perhaps the exception of one paper, which treats of the isomerism of methyl uric acids. The contents of this first chapter is almost complete, and gives a full survey of the subject as it is known to-day. Following this is the

second part of the book, which contains the forty-seven publications of the author and his students. The first forty contain the work previous to 1899, while the remaining seven have been published subsequent to the compilation of the introduction. These papers contain the complete experimental data of the originals, and are given in the order of publication. It is quite impossible to read this book without marvelling at the wonderful fertility of the brain of this modern genius. No problem seems to be too great for his inventive faculty. Even the incomplete work of Baeyer receives new life in his hands. It is not with the purine derivatives only that one associates the name of E. Fischer, but many other groups have been added to the list.

It will be remembered that the author published his book on the amido-acids and proteins about a year ago. The success of this volume is the direct cause of the present one, which was written with the same object as the former. The literature on the subject is contained in various journals, and these are not always accessible to students of science. The demands of modern science, on the other hand are such that it is of vital importance to be able to acquire a detailed knowledge of many highly specialised subjects without any great inconvenience. The literature of the biologist, for example, is already voluminous enough to require his whole attention without having to keep in touch with chemical developments. For such students this book was originally intended, and these will undoubtedly feel grateful to the author. These, however, are not the only men of science who owe gratitude to E. Fischer. Every modern chemist should read this book, not only for the individual results, but to gain a better knowledge of the wonderful methods of manipulation employed. These are of general importance. Throughout, the well-worn track of modern methods is employed, but, as a rule, small alterations—vital to success—are made. It is here that the special genius of the author is seen at its best, for which the whole of the scientific world must express its thanks.

OUR BOOK SHELF.

Iron and Steel. By J. H. Stansbie. Pp. xiii+375. (London: Archibald Constable and Co., Ltd., 1907.) Price 6s. net.

DURING the last few years so many elementary books on iron and steel have been published that it would almost appear that an addition to the long list was unnecessary. Mr. Stansbie's book is, however, an excellent one. Written from the notes of his lectures to students of the Birmingham Municipal Technical School, it gives as comprehensive a view as its limits permit of the modern aspects of iron and steel manufacture, together with historical details sufficient to enable the student to follow the march of progress. It is printed in clear type, and the eighty-six illustrations, although they would have been improved by an indication of the scale, are well chosen and well adapted to indicate to students the construction of the furnaces described.

In arrangement of the subject-matter, the work differs but slightly from many of its predecessors. An introductory chapter on chemical principles is fol-

lowed by chapters on iron ores and fuels, primitive methods of iron and steel production, pig iron and its manufacture, the refining of pig iron in small charges, crucible and weld steel, the Bessemer process, the open-hearth process, mechanical treatment of iron and steel, physical properties of iron and steel, iron and steel under the microscope, heat treatment of iron and steel, electric smelting, and special steels. The information given has been brought up to date by reference to the latest books and to papers read before the Iron and Steel Institute. The book is commendably free from misprints. The names of Brinell and Legéniel are, however, wrongly spelt; and there appears to be some inaccuracy in the statement that an American blast furnace producing 800 tons of Bessemer pig iron in twenty-four hours would yield 1200 tons of slag during that period. The author probably intended to have said that the furnace would yield 1200 lb. of slag per ton of pig iron made.

L'Énergétique et le Mécanisme au Point de Vue des Conditions de la Connaissance. By Abel Rey. Pp. 187. (Paris: Félix Alcan, 1908.) Price 2.50 francs.

In a former work, recently noticed in these columns, M. Rey analysed contemporary physical theories with the object of showing that, in spite of profound differences of procedure, they all bear witness to a common basis of assured experiential fact. In the present book he considers the two rival points of view under which modern theories are ranged—those of the Newtonian mechanics and of the newer energetics—with the more practical purpose of determining whether either of them possesses intrinsic superiority over the other.

There are two fundamental laws of progress in knowledge—it advances by repeated assimilation of the unknown to the known, and with constantly rhythmic alternation of generalisation and deduction. The progressive interpretation of the physical aspect of nature by the concepts of the traditional mechanics complies with each of these laws, while energetics, which seeks merely a single formula from which the established particulars of experience may be formally deduced, runs counter to both. Thus the former alone can be permanently an efficient instrument of investigation.

This, in brief, is M. Rey's thesis. It need be added only that it is worked out in a very interesting manner, and with a competence that should render his study of equal value to the man of science and the epistemologist. T. P. N.

Abel's Laboratory Handbook of Bacteriology. Translated from the tenth German edition by Dr. M. H. Gordon; with additions by Dr. A. C. Houston, Dr. T. G. Horder, and the Translator. (Oxford Medical Publications.) Pp. xi+224. (London: Henry Frowde, and Hodder and Stoughton, 1907.) Price 5s. net.

The fact that Abel's handbook of bacteriology has reached its tenth German edition is sufficient proof that it fulfils a useful purpose, and the appearance of this translation will render it available for British and American laboratories. It is just the book for the laboratory table, giving the practical details which are so often required immediately to hand, and the binding in glazed covers will render it less liable to be soiled. The work of British investigators is adequately noticed, and the section on the examination of water, milk, shell-fish, &c., is contributed by Dr. Houston, a sure guarantee of its trustworthiness. The translation is sometimes a little clumsy, e.g. "salad" potatoes (p. 26). The culture of the glanders bacillus on potato is inadequately and incorrectly described, and the proof reading has evidently been carelessly done. Thus NaCl for NaCl, and HCl for HCl

occur several times, and the iodine solution used in Nicolle's modification of Gram's method is stated to have the following composition:— $\text{IK} + 2\text{KI} + 200 \text{ Aq.}$ (for $\text{IK} + 2\text{KI} + 200 \text{ Aq.}$). Apart from such small blemishes, the book can be recommended as a most useful laboratory guide. R. T. HEWLETT.

Die Bestimmung und Vererbung des Geschlechtes. By Dr. C. Correns. Pp. v+81. (Berlin: Gebrüder Borntraeger, 1907.) Price 1.50 marks.

In this volume, Dr. Correns makes another contribution to the subject that he has studied for many years, of hybrids and their hereditary characters. An attempt is made to throw some light on sex tendency in germ cells, to discover the stage at which the sex-character is determined, and to find out whether sex tendency appears to conform to Mendelian laws, or, in Mendelian phraseology, whether sex may not be a consequence of gametic segregation. The method has been to raise hybrids, using for one or both parents monoecious or dioecious plants. The earlier experiments were made with the monoecious *Bryonia alba* and the dioecious *Bryonia dioica*. When pollen of the former was applied to stigmas of the latter, the resulting plants were female, some few showing traces of monoecism. The converse produced half male hybrids, half female, but most of the latter showed a tendency to monoecism. Sterility of this first generation put a stop to further experiments. A result was also obtained by pollinating the flowers of *Melandrium album* with pollen from *Silene viscosa*. From his interpretation of the results, Dr. Correns concludes that sex determination is a simple inheritance phenomenon conforming to Mendelian laws of segregation; that the females are homozygotes, the males are heterozygotes. This last supposition is, however, opposed to the idea postulated by Castle that no sex characters are homozygous. Apart from the Mendelian argument, the reader will find some suggestive remarks with regard to the inheritance of sexual characters.

Lehrbuch der Physik. By Prof. H. A. Lorentz. Translation from the Dutch by G. Siebert. Second volume. Pp. iv+621. (Leipzig: J. A. Barth, 1907.) Price 10 marks.

This is a translation from the fourth Dutch edition of Prof. Lorentz's text-book. The mastery of the author over the facts of physics is, of course, a guarantee of the excellence of the exposition. The contents of this volume are connected with sound, light, electricity, and magnetism. The treatment is exceedingly simple; if we have any criticism to make it is that most students, even though not taking up physics as one of the principal subjects of their study, would like to learn more than the book offers. In other words, we think that in many places the treatment is unnecessarily meagre. We are sure that the chemist would like to be told more about theories of the voltaic cell. The large amount of work that has been done by physical chemists under the leadership of Ostwald and Nernst is left absolutely unnoticed.

We turn naturally to the chapter at the end on the electron theory. Here, as elsewhere, what there is is excellent; but we feel that we expected more on this subject from Prof. Lorentz. There are so many phenomena known now which are capable of being simply described and used in illustration and support of the modern fluid theory of electricity. This scantiness will probably tell against the book competing with others of a similar grade, in England at any rate.

A collection of 72 examples appears at the end; solutions are not given to these. There are also fifteen useful tables of data.

LETTERS TO THE EDITOR.

[The Editor does not hold himself responsible for opinions expressed by his correspondents. Neither can he undertake to return, or to correspond with the writers of, rejected manuscripts intended for this or any other part of NATURE. No notice is taken of anonymous communications.]

The Condensation of Helium.

In addition to my short note printed in last week's NATURE (p. 559), let me begin by remarking that as recently as last year, in an address to the Dutch Congress of Natural Science and Medicine, I expressed the opinion that it would be scarcely possible to liquefy helium. Olszewski, from his expansion experiments, had deduced that the critical temperature of helium was lower than 2° K. Dewar had no more succeeded in liquefying it by expansion, and some experiences of my own on helium gas sinking in liquid hydrogen seemed to indicate that helium was nearly a perfect gas. At the same meeting I indicated the determination of the isothermals of helium, an investigation with which I was occupied, and which I had prepared by a series of researches, as the direct way to the calculation of the critical temperature.

The first results I obtained with the isothermals changed totally my views on the liquefaction of helium. From the isothermals down to -217° , it followed that the critical point of helium is at nearly 5° K., more in harmony with the estimate of the boiling point at 5° or 6° K. by Dewar, according to the helium absorbed in charcoal, and the determinations at -252° C. and -259° C. confirmed the result. It thence followed that it would be possible, by rapid expansion of helium compressed at 100 atmospheres at the melting point of hydrogen, to pass below the critical temperature, and to cause a mist to appear in the gas. Also liquefaction by the Joule-Kelvin effect seemed possible. It was to put the first conclusion to the test that I made my recent experiments.

The new features of my application of the expansion method to helium were:—(1) the great quantity of gas; (2) the application of a stop-cock on the tube to let off the gas from the tube into a gas-holder, a gas-bag, or a vacuum; (3) an extremely thin-walled beaker, placed in the thick-walled tube to protect the cooled gas against heat conduction. These devices had been used by Olszewski in his experiments on the expansion of hydrogen.

At the expansion a dense cloud appeared, from which solid masses separated out, floating in the gaseous helium, resembling partly cotton-wool, partly also denser masses, as if floating in a syrupy liquid, adhering to the walls and sliding downward, while at the same time vanishing rapidly (20 seconds). There was no trace of melting.

So far as I could judge, then, from my experiments, I considered it probable that this solid substance was helium. The helium had been burned with copper oxide and passed over charcoal at the temperature of boiling hydrogen, and I trusted to have a gas with only very small admixtures. If helium passed immediately to the solid state, then the position of the vapour-line to the adiabatics would be more favourable for condensation than if it passed into the liquid state, and the voluminous aspect of the solid mass was in harmony with this. By the above, and also by other observations, which afterwards gave rise to doubt or proved incorrect, I was for some time under the impression that I had seen solid helium rapidly giving off vapours of the pressure shown by the gas (once more than 15 atmospheres was shown). The continuation of my experiments has shown that they must be explained in quite a different way. By a not sufficiently explained cause, the gas proved to be not so pure as was supposed, considering the method of purification. In analysing what was absorbed by charcoal at the temperature of boiling hydrogen until the charcoal removed no more hydrogen, so that the gas could only contain traces of hydrogen, it could be proved that in one case the gas had contained only 0.45 and in another only 0.37 volume per cent. of hydrogen at most. (About a small possible quantity of neon I could not yet be certain.) But this small admixture must have had a very great influence: for at a first repetition of the experiment with the helium subjected to this new treatment no cloud at all was observed. In this

experiment the velocity of expansion had been too small. At a second repetition with the same gas, but with greater velocity of expansion, a thin cloud appeared and vanished extremely rapidly (1 second). The mist now had a different aspect.

The explanation of the previous observation is to be found in solution phenomena of solid hydrogen in gaseous helium. The phenomena which made the impression of being the giving off of vapour had been the solution of deposited solid hydrogen in the gaseous helium, the latter rapidly returning from the lower temperature to that of melting hydrogen, and the pressure increasing in consequence. Helium at the temperatures that come into account here can, according to the theory of mixtures, take up at every temperature a percentage of hydrogen, determined by that temperature in such a way that it is not deposited at any pressure. With acceptable suppositions one can deduce that at temperatures above the melting point of hydrogen this percentage can be considerable, and that at this melting point itself it can be more than 1 per cent.

From mixtures with smaller percentage, the hydrogen is only deposited at lower temperatures, e.g. by expansion. By the smallness of the quantity of hydrogen present it is also explained that, after prolonged blowing off of the helium, no solid hydrogen was left, for the quantity was so small that it could evaporate in the space which it found at its disposal. It is remarkable that so small a quantity of admixture as the gas contained has been able to give the total phenomenon of a substance condensing to a solid and re-evaporating, though the rapid evaporation is in harmony with the smallness of this quantity of substance, considering that even denser masses were seen to be blown away sometimes. There cannot have been much more than 1 milligram or 15 cubic millimetres of solid hydrogen in round numbers in the tube—probably there was less in it—and yet the tube of nearly 7 cubic centimetres was over its whole length for almost a quarter filled with dense, flaky substance.

So far as the experiments on the expansion of helium are now advanced, they show the curious forms that the solution phenomena of a solid in a gas take in the case of helium and hydrogen. They further point to the possibility of realising with mixtures of hydrogen and helium the rising or falling of the solid substance according to the pressure exerted on the gas, the barotropic phenomenon for a solid and a gas. But the question of condensing helium is to be considered yet as an open one.

Let me add a few words as to the mist observed in the repetition of the expansion experiment with the "coal-pure" gas. It is certain that this gas only contains very small quantities of hydrogen. The spectroscopic test also gives traces only. It is possible that the amount of the traces will prove sufficient to attribute the mist to the traces of hydrogen left in the gas. But it is also possible that the mist has been a liquid cloud, and the changed aspect seemed to point to this. If this might prove to be the case, then the critical point would be nearly what I calculated from the isotherms, and helium would obey tolerably well the laws of van der Waals. The tube broke, and so I could not attain more certainty about the nature of the cloud.

The preceding experiments show very strikingly how careful one has to be in arriving at conclusions from the appearance or non-appearance of a cloud by expansion. A decision about the critical point of helium is therefore only to be obtained by a prolonged systematic investigation, which will take much time.

April 14.

H. KAMERLINGH ONNES.

Satellites of Yellow and Green Lines of Mercury.

BEING engaged with the investigation of the Zeeman effect by using a 35-plate Echelon spectroscope constructed by Hilger, I made an experimental test of the resolving power of the instrument on the yellow and green lines of mercury. With a lamp of the Aron type (30 volts, 6 amperes), and by eye observation with a micrometer, I found the following satellites, some of which seem to be new. $\delta\lambda$ is given in Angström units. The measurements by Janicki with an Echelon spectroscope, and by Baeyer

with Lummer-Gehrcke plates, are cited for the sake of comparison:—

$\lambda = 5790$ (Yellow line).			
Observed $\Delta\lambda$	Intensity	Janicki	Baeyer
-0'266	...	-0'251	...
-0'170	...	-0'187	-0'19
-0'122	...	-0'119	-0'127
-0'077*	...	—	—
-0'032*	...	—	—
Principal Line		Principal Line	Principal Line
+0'035*	...	—	—
+0'073	...	+0'084	—
+0'142	...	+0'132	+0'139
+0'189	...	+0'168	—
+0'235	...	+0'230	+0'237
$\lambda = 5461$ (Green line).			
Observed $\Delta\lambda$	Intensity	Janicki	Baeyer
-0'247	...	-0'232	-0'250
-0'216*	...	—	—
-0'175*	...	—	—
-0'142*	...	—	—
-0'110	...	-0'099	-0'107
-0'084	...	—	-0'072
-0'058	...	-0'066	-0'051
-0'024	...	—	-0'025
Principal Line		Principal Line	Principal Line
+0'033*	...	—	—
+0'068*	...	+0'088	+0'087
+0'109*	...	—	—
+0'143	...	+0'133	+0'132
+0'201*	...	—	—
+0'230	...	—	+0'222

Some of the lines not observed by Janicki and Baeyer, and marked with an asterisk, seem to be new, but the scanty literature on spectroscopy at my disposal does not permit me to conclude which of them were observed for the first time.

Of the numerous satellites of the green line, -0.232, observed by Janicki, is separated into two lines, -0.247 and -0.216, and -0.099 into two, -0.110 and -0.084. The lines -0.216 and +0.033 are evidently the same as -0.208 and +0.032 given by Gray and Stewart. The satellite +0.087 observed by Baeyer, +0.088 by Janicki, +0.093 by Gehrcke and Baeyer, +0.082 by Fabry and Perot, and +0.084 by Houston is resolved into two components of nearly equal intensity, +0.068 and +0.109. Gray and Stewart give only +0.067. The green line was separated into twenty-one components by Lummer and Gehrcke, with a single interference plate; here it is separated into fifteen lines. Some of these lines will be separated into components by increasing the resolving power.

The spectrum produced by heating an ordinary vacuum tube of H-shape containing a few drops of mercury, and excited by an induction coil, gave results almost coinciding with those of Janicki, as observed by Mr. Amano and myself. The appearance of the satellites seems to be influenced greatly by the construction of the tube and the mode of excitation. H. NAGAOKA.

Physical Institute, Tokyo University, March 15.

Mendelian Characters among Shorthorns.

I was much interested in Prof. James Wilson's letter in NATURE of April 2, and I sent the number to my friend, Mr. William Duthie, of Collynie, Tarves, Aberdeenshire, a well-known breeder of Shorthorns of the first class, in the hope that Mr. Duthie, from his own experience, might check some of the numbers given by Prof. Wilson. Mr. Duthie sent my note to Dr. Thomas F. Jamieson, of Ellon, who is also a famous breeder of Shorthorns, as well as an agricultural chemist of repute. Dr. Jamieson wrote to Mr. Duthie, and I have the authority of both to send the following extract from his letter, which will interest, not only Prof. Wilson, but also those who may be collecting statistics regarding the Mendelian aspects of the problem of heredity:—

"I have long been of opinion that the Shorthorns have arisen from a combination of a red breed and a white one.

There is a remarkable tendency in them to produce animals which are *entirely* white (unless, perhaps, the cars), more so, I think, than those which are entirely red, and I find that of the white calves the majority are females. I would like you to test this latter point from your own knowledge, in order to see if you also find it so. There is no doubt that a red bull mated with a red cow will almost always produce a red calf, more especially if the bull's own parents were both red, and similarly with white upon white. My red bull "Topsman," 63,447, gave me 113 calves, and not one of them white. He was mated eleven times with a white cow, and the result was ten roans and one red. He was mated sixty times with a red or red-and-white cow, and *every one* of the calves was red. He was mated forty-two times with a roan cow, with the result that twenty-three of the calves were roan and nineteen red. "Topsman" had white socks on the hind shanks, and several of his calves had so too, probably about twenty-six of them, or 23 per cent."

JOHN G. MCKENDRICK.

Maxieburn, Stonehaven, April 11.

Ionisation of Air by Ultra-violet Light.

SINCE Lenard has shown that ionisation of the air is produced by light of short wave-length, it has seemed advisable to extend his researches into the region of the extreme ultra-violet, discovered by Schumann, and to investigate the effect on air of light of wave-length below λ 1850.

For this purpose, a discharge tube filled with hydrogen to a pressure of 1 mm. of mercury, and a screen-cell, were used, both similar to those described by Prof. Lyman in the *Astrophysical Journal*, March. Below the screen-cell was a chamber where ionisation took place. Dry, dust-free air was blown through this chamber into a cylindrical condenser system. The ionisation produced by the light from the vacuum tube was measured by the charge acquired by one of the cylinders, the other being kept at a constant potential. The air pressure in the screen-cell could be varied at will. Precautions were taken to guard against surface effects.

Under these conditions, it has been found that the ionisation increases in a most marked degree as the pressure in the screen-cell is decreased. It is, therefore, evident that ionisation is produced in air by light from that part of the spectrum discovered by Schumann, and that the effect increases considerably with decrease in wave-length, at all events, in the neighbourhood of λ 1800.

It is proposed to investigate the effect in some of the elementary gases.

FREDERIC PALMER, jun.

Haverford College, Haverford, Pa., U.S.A.,

April 10.

THE INTERNATIONAL MATHEMATICAL CONGRESS AT ROME.

THE congress of 1908 has been considerably larger than its three predecessors. Up to April 4, the official membership list contained 648 names, but later additions have increased the number of those present to about 530 members, and 167 ladies accompanying them. The weather has been of the same unsettled character that we are accustomed to describe as "British Association weather," but the brilliancy of the gatherings has not been materially affected by the spells of rain.

The proceedings commenced with a reception at the University, given by the rector (Prof. Tonelli) on Sunday, April 5, but the congress was formally opened on the following morning in the Hall of the Horatii and Curatii at the Capitol, in the presence of the King, when addresses were read by Mr. Nathan, Mayor of Rome, by Prof. Blaserna, representing the Reale Accademia dei Lincei, and by the Minister of Public Instruction.

A discourse was afterwards read by Prof. Vito Volterra on mathematical progress in Italy during the

last half of the nineteenth century. Prof. Volterra discussed the work of Cremona, Betti, Brioschi, Beltrami, Fergola, Battaglini, and Dini, and directed attention to the recent publication of Galileo's complete works under the patronage of the King.

The subsequent meetings were held in the magnificent suite of rooms occupied by the Reale Accademia dei Lincei at the Palazzo Corsini, where ample accommodation was available for general and sectional meetings, as well as secretarial and post offices and a buffet. The pretty garden behind the palace was also thrown open, and in the groves the wild *Bellevalia romana* was in full flower. A service of automobiles running intermittently to and from the middle of the town was placed at the disposal of the members. At the first general meeting a report was presented by Profs. Segre, Noether and Poincaré, awarding the Guccia medal to Prof. Francesco Severi for his work on geometry of algebraic surfaces. Subsequently Prof. Mittag-Leffler gave a lecture on the arithmetic representation of analytic functions of a complex variable, and Prof. Forsyth lectured on the present condition of partial differential equations of the second order as regards formal integration.

The sectional meetings commenced on Tuesday morning, April 7, the sections being as follows:—i., analysis; ii., geometry; iii.a, dynamics and mathematical physics; iii.b, statistical and practical applications; iv., philosophy, history, and teaching of mathematics.

In the section of analysis, Prof. Marcolongo directed attention to the lamentable death on March 30 of Dr. Laura Pisati, who was at that time preparing her paper for the congress entitled "An Essay on a Synthetic Theory of Functions of a Complex Variable." From a long list of subsequent papers the following may be selected:—Jordan, solution of the sextic; Borel, theory of groups; Frizel, power of continuum; Young, applications of semi-continuous functions; Schlesinger, parametric problems in the theory of linear differential equations; Rémondos, zeros of integrals of a class of differential equations; Volterra, method of images in the hyperbolic type; E. G. Moore, a form of general analysis; Fredholm, Fourier's integrals and theory of linear integral equations; Adhémar, equations of Fredholm and Volterra; Orlando, resolution of integral equations; Stéphanos, extension of invariant and covariant theory of binary forms.

In the geometry section, we note Andrade, theorem of Ampère-Stockes and Euclid's postulate; Bagnera, algebraic equations resolvable by meromorphic functions which are quadruply periodic in two parameters; Severi, certain results in algebraic geometry with special reference to the irregularities of a linear system; Bianchi, Darboux's transformation of surfaces of minimal area; Brouwer, a theory of groups independent of the axioms of Sophus Lie.

In section iii.a, Sir G. H. Darwin gave a communication on the rigidity of the earth, illustrated by diagrams showing the displacement of the vertical when the moon has a high north or south declination. It was estimated that the earth's surface rose and fell 17 cm. with the tides, and 20 cm. with variations of barometric pressure. Among other papers we notice Lauricella, certain extensions of the equation of elasticity; Lamb, a theoretical confirmation of the engineers' approximate treatment of bending of beams; E. E. Levi, discussion of certain elastic deformations which satisfy Weingastein's but not Volterra's condition; A. Korn, an attempt to build up a theory of pulsating spheres capable of accounting for electrical as well as gravitational phenomena; Levi Civita, retarded potentials; Garbasso, white light;

Greenhill, geometry of gyroscopic motion, descriptive of a method of drawing families of curves hodographic to the Poinsoet herpolhode; Sommerfeld, an attempt to account for turbulent motion of viscous liquids; Genese, reciprocal polars applied to statics; Kolossoff, elastic problems in two dimensions treated by complex variables.

Section iii.b met on three days only, the first two being devoted to statistical problems, with special reference to life assurance. An address was given by the chairman, Signor Guido Toja, on the relations between mathematics and actuarial science, and the papers included Dawson, on necessary cautions in dealing with actuarial problems; Borel, application of probability to biology; Castelli, the teaching of actuarial science; Poussin and Elderton, papers of a graphical character; March, population statistics. The third sitting was devoted to the mathematics of engineering and building, a subject introduced by Prof. L. Luiggi. Papers were read by Prof. D'Ocagne, representing the French Office of Works, on the calculus in engineering, and the approximate rectification of circular arcs; by Swain, on teaching of mathematics for engineers; by Canevazzi, and finally by Claxton Fidler, on the theory of construction. The last-named communication derives considerable importance from the reference to the comparatively recent bridge disaster in America, which a mathematical investigation proved to have originated through one of the stays having had to play the part of a strut during the process of construction, thereby causing buckling, which would not have occurred in the completed structure.

The fourth section was devoted on the Tuesday morning mainly to philosophical aspects of mathematics, the subject being introduced by Prof. Federico Enriques. A discussion between Profs. Itelson and Pastor was a noticeable feature of the proceedings. On the Wednesday and Saturday the discussions were mostly historical. Prof. Krazer directed attention to the publication of Euler's works, in accordance with a wish expressed at the previous congress, and proposed a vote of congratulation to the Swiss Society of Naturalists, which had undertaken the initiative in this task. It was further proposed to invite the Association of Academies, and the Academies of Berlin and St. Petersburg in particular, to assist in preparing the volumes. A proposal was made by Prof. Amodeo in favour of the publication of the collected works of Bonaventura Cavalieri. Thursday and Friday were devoted to the teaching of mathematics. A number of reports had been invited as to the position of mathematical teaching in the schools of various countries. Germany was represented by Gutzmer, France by Borel, Great Britain by Godfrey (whose paper was summarised by Vailati, and discussed by Gibson), the United States by D. T. Smith, Austria by Suppantichitsk, Hungary by Beke, Italy by Vailati and Conti, Switzerland by Fehr, Greece by Stéphanos. Prof. Archenhold proposed that a standing committee should be formed for the study of questions regarding the teaching of mathematics in secondary schools, this motion being carried in the section. Prof. Loria presented the first copy of the fourth volume of Moritz Cantor's "Vorlesungen über Geschichte der Mathematik," and a volume containing the report of the educational committee of the German Association of Naturalists and Physicians was presented by Prof. Gutzmer.

The sectional meetings have, as a rule, lasted only about a couple of hours, leaving plenty of time for exchange of ideas between individual congressists outside the formal meetings.

The discourses, occupying a little under an hour

each at the general meetings, have been another important feature of the congress. We have referred to the first three of these discourses; the remainder were as follows:—Darboux, methods and problems of infinitesimal geometry; von Dick, the Mathematical Encyclopædia; Newcomb, the theory of the lunar motion, its history and present state; Lorentz, partition of energy between matter and ether; Poincaré, an address read by Prof. Darboux on the future of mathematics; Picard, analysis in relation to mathematical physics; G. Veronese, non-archimedean geometry. A lantern lecture was given by Prof. Stormer on the trajectories of electrified corpuscles in the field of a magnetic molecule, with applications to the Aurora Borealis.

On the Wednesday evening a conversazione was given by the Municipality of Rome in the museum of the Capitol, which was brilliantly illuminated for the occasion; the reception commenced at 10 p.m., and lasted until the early hours of the next morning. On the Thursday the congress was entertained to a sumptuous tea, by invitation of the Minister of Public Instruction, at the Stadium discovered in 1893, on the Palatine Hill. The old mausoleum of Augustus has within the last two months been transformed into a concert hall, the stalls in which alone contained ample accommodation for the whole of the congressists. Here, on the Thursday evening, we listened to an orchestral concert conducted by Signor Luigi Mancinelli. The programme would be generally described as modern music; most of it was certainly very "modern."

A fitting termination to the work of the congress was afforded by a splendid open-air banquet at Tivoli, given in the grounds of the Hotel des Cascades on the Sunday, the morning being spent, so far as time allowed, in exploring Hadrian's Villa, where the *Incumone apennina* and other spring flowers were in full bloom, while a hurried visit to the cascades, temple of Serapis, and pretty gardens of the Villa d'Este, sometime known as the Villa Hohenlohe, occupied the too short interval after luncheon until the "steam rumbler" whirled us back to Rome, where we parted, hoping to meet in Cambridge in 1912.

In the official list of congressists we note about twenty-two English names, one with a German address and another from Egypt. That Great Britain should only be represented by four per cent. of the total number of congressists affords abundant evidence of the position of isolation into which our nation has drifted in its neglect of higher mathematics. There were many proofs that the Italian as well as the German mathematicians present constituted a powerful and influential body, and the presence of the King at the inaugural meeting—an honour rarely conferred on such occasions—together with the brilliancy of the receptions, afforded evidence of the esteem in which Italy holds the mathematical professors of her universities.

The French Government was represented officially by six delegates, besides special representatives of its Office of Works and statistical service. The Governments of Hungary and Roumania sent delegates, as did also many Continental actuarial societies and insurance companies. It is greatly to be hoped that the decision to hold the next congress in Cambridge may be the means of awakening our country to the great disabilities under which English mathematicians labour, in regard to higher study and research, in comparison with the mathematicians of other nations. If any good is to be done, the Cambridge congress must consist of something more than a mere display of hospitality towards foreign mathematicians. A

determined effort must be made to work up a large English contingent to meet and exchange ideas with the congressists of other countries. A strong feeling has been expressed against the English practice at such occasions of officially providing private hospitality for some members and not for others, and it has been felt that the success of these foreign gatherings is largely due to the absence of any organised system of limited hospitality. Such a system necessarily divides the members into two parties, and raises up a barrier to free intercourse between them.

The invitation to Cambridge was proposed by Prof. Forsyth, who represented the Cambridge Philosophical Society. It was seconded by Prof. Blaserna, president of the present congress, and carried enthusiastically. For the congress of 1916, Stockholm has been proposed.

Before concluding, mention should be made of the special privileges offered by the Government and Municipality in throwing open all their museums and excavations to the congressists; the important concessions made by the Italian State Railways; and, last but not least, the unflinching courtesy of the local committee, under the secretaryship of Prof. G. Castelnuovo, through whose exertions everything passed off with the greatest success.

G. H. BRYAN.

JUBILEE OF THE CALCUTTA UNIVERSITY.

VERY few institutions have had such a remarkable influence on the history of any country as has been the case with the University of Calcutta, which celebrated its jubilee on March 14. To put the case on the lowest ground of mere numbers, while in the first year of its existence less than fifty students appeared at all its examinations for the matriculation upwards, during the last few years about 7000 students have appeared annually for its matriculation examination alone, while also in this jubilee year no fewer than 855 students have taken their degrees in such subjects as arts, science, medicine, law and engineering.

Educational effort on Western lines has naturally been of comparatively recent development in India. For many years after the East India Company had taken over the administration of the territories which had been acquired in India, no attempt was made to establish any regular system of education, and, indeed, no pains seem to have been taken even to foster the indigenous systems which had been in existence throughout the country for many centuries. Later on spasmodic efforts were, however, made to try to prevent the higher forms of oriental learning from falling into decay by the establishment of the Calcutta Madrasah in 1782, intended for Mohammedans and for the study of Arabic and Persian, while a college for Hindus was started nine years later, the aim of which was to foster the study of Sanskrit and Sanskrit languages.

The general neglect of education by the administration continued up to about 1813, from which time public funds appear to have been set apart systematically for the furtherance of education. Up till about 1835 education was conducted largely by oriental methods and in oriental subjects, and the authorities were bent upon the improvement of education by the encouragement of those learned in Sanskrit and Arabic. At that time Lord Macaulay wrote a minute, which has since become historical, advocating the introduction of Western education into India, and the teaching of all the higher subjects through the medium of English. From 1835 to 1854 there was much controversy as to which of these two

systems was best; but the teaching of English continued to make fairly rapid headway, and was popular with Indian gentlemen. A despatch from the Court of Directors of the East India Company, written by Sir Charles Wood in 1854, dealt with the whole question in a most masterly way, and practically set the question at rest in favour of the higher teaching being conducted on Western lines and through the medium of English. This despatch was quickly followed in 1856 by the creation of regular education departments in the great provinces of India, manned largely by graduates of English universities, and in 1857 by the establishment of the Calcutta University, and later on of the Universities of Madras and Bombay.

It says much for the faith and energy of those in power in India in 1857 that during the actual period of the Indian Mutiny steps were being taken to create Indian universities, and to foster in every way the educational advancement of the country.

The Calcutta University thus had a clear and favourable field for its operations, for the spread of education through the medium of English was at once warmly welcomed by Indian gentlemen, and year by year it continues to increase in favour. So rapid, indeed, has been the growth of high education in India that within the area originally allotted to the Calcutta University, two other universities (Punjab and Allahabad) have had to be created, and still the numbers from the restricted area are almost more than can be dealt with by that university.

At the time of the formation of the Calcutta University the London University was thought to be the best model to be followed, but judging by results it would probably have been better if the model of the older universities had been followed, if residential colleges had been formed, and if a teaching rather than an examining university had been started. In time probably the latter will be the ideal which will be aimed at in India.

The Calcutta University, for nearly the first fifty years of its existence, has confined itself mainly to the task of merely examining students sent up to it from recognised or affiliated institutions. Of course, by laying down subjects for examination the university has practically determined the subjects which had to be taught in the colleges and schools sending up the candidates, but the university has hitherto exercised no control as to the fitness of the affiliated institutions for the work they were supposed to carry on. At first little trouble arose from this fact, but great difficulties arose owing to the extraordinarily rapid growth in the number of colleges and schools, which rose at one time to about eighty colleges and about 600 schools, which had the privilege of sending up candidates. Many of such institutions were competing with each other with fierce rivalry, and some, if not many, attracted students largely by lowness of fees and laxity of discipline. Many institutions were thus working under unsatisfactory conditions, they were inadequately and imperfectly staffed, and they had few teaching appliances. They suffered indeed so acutely from extremely inadequate funds that really they could not do more than they were actually doing. With the sending up of very large numbers of imperfectly trained candidates for examination, and their consequent failure, the usual desire to lower standards was manifested, and the examinations almost necessarily became suited to the average level of the affiliated institutions and to the teaching there given.

It was with a view to raise the whole tone and standard of university education in India that a new University Act was passed some four years ago, and under this a complete set of new regulations has been framed. Under them standards are being raised,

courses are being made more thorough, examinations are being made more practical, specially in the science subjects, original research is being fostered, and has been made compulsory for the higher degrees in science and literature, and post-graduate study is being encouraged by the creation of university readerships and professorships.

In other important matters attempts are being made to deal with the residence and discipline of college students, and to bring influence to bear on the formation of their characters. In the past the condition of affairs in these respects has been somewhat deplorable, and the general influence of the surroundings of students has left much to be desired. What is really wanted for India is a series of residential colleges of the type of the Mohammedan college at Aligarh, in the United Provinces, where most excellent work is being done, intellectually, physically, and morally. Under these new regulations, in order to retain affiliation or recognition, all institutions sending up candidates to the Calcutta University have to be inspected periodically by the university authorities, and are bound to conform to certain standards of work, of equipment, and of care for the well-being of their students, while numerous other reforms have been insisted on.

The new regulations are being gradually but firmly introduced, under the Vice-Chancellor, Mr. Justice Asutosh Mukerji, who is one of the most distinguished of the graduates of the Calcutta University, but it will naturally take many years before their full effect will be felt. In the future too much stress cannot be laid on the desirability of closer and closer union between the colleges and the university, and the assumption of the higher teaching by or under the immediate direction of the university itself. The development of the residential system is also much to be desired if discipline is to be improved and character formed. The eloquent speeches delivered at the Convocation on March 14 by H.E. the Chancellor (Lord Minto), and the Vice-Chancellor (Mr. Justice Mukerji), show that these objects are being steadily kept in view, and that the work of reform is progressing steadily, and perhaps even rapidly. It will hence be agreed that there is a bright future in store for the Calcutta University.

RECENT WORK ON PLAGUE.¹

SINCE Yersin's discovery of the *Bacillus pestis* in 1894, bacteriological experiment has shown the possibility of spreading plague infection among rats and other mammals through the intermediation of fleas. The reports before us are concerned especially with the proof that this is the means by which epidemics are actually set up. Such proof may be summed up as follows:—

In the first place Major Lamb, with the members of the commission, who carried out the work under the aegis of the advisory committee, shows by numerous charts and by series of maps that the epidemic follows closely in time and place the distribution of the epizootic among *Mus rattus*. In Bombay this epizootic, in its turn, is similarly related to that among *Mus decumanus*. In earlier reports they have dealt with the results obtained by using

¹ (1) *Journal of Hygiene*, vol. vii., No. 6, December, 1907. Third extra number, containing Reports on Plague Investigations in India, issued by the Advisory Committee appointed by the Secretary of State for India, the Royal Society, and the Lister Institute. (Cambridge: University Press.) Price 6s.

(2) "Report on Plague in Queensland (February 26, 1900—June 30, 1907)." By B. Burnett Ham. (Brisbane: Public Health Department, 1907.)

(3) "The Etiology and Epidemiology of Plague. A Summary of the Work of the Plague Commission." Pp. vi+93. (Calcutta, 1903.) Price 4 annas, or 6d.

Liston's ingenious method of experimentation with guinea-pigs. It has been shown that these animals are very rarely infected from soil or clothes grossly contaminated with cultures of the *Bacillus pestis*, or from other plague-infected guinea-pigs, so long as fleas are excluded. On the other hand, they readily contract plague when exposed to the attacks of fleas which have fed on plague-infected animals. Following up this method, the commission placed healthy guinea-pigs in buildings where it appeared that plague was contracted, and found that the test animals died of plague, and, further, that the fleas they picked up in these surroundings could be transferred to fresh animals in the laboratory and infect them also with plague. An exceedingly interesting experiment on these lines was carried out in Sion Village. One part of this village was evacuated by the inhabitants on the discovery of a dead rat. The commission at once took advantage of the "guinea-pig method," and substituted a population of healthy guinea-pigs for the decamped inhabitants. These guinea-pigs were confined to their several houses, and all chance of direct spread of infection among them was excluded. In these circumstances an epizootic appeared among the new population, which progressed through the village, following the distribution of a simultaneous epizootic among the rats (*M. rattus*). The guinea-pig plague was so severe that thirty-six out of fifty-one animals put in the houses died.

The evidence brought against the direct spread of plague from man to man rests on the immunity of hospital staffs, and of friends of patients in hospital, who very frequently lived at the bedside throughout the course of the disease. Again, the village of Worli offered an example of what often occurs. Three cases of plague were imported into the village, but in the absence of an epizootic the infection did not spread.

With regard to the beginning of an epizootic in a fresh locality, it seems that infection may be carried by a healthy man and spread from him to the rats of his dwelling. Such infection, the commission supposes, is flea-borne. The yearly recrudescence of plague may be due to such fresh importation, or to the persistence of acute plague throughout the year, affecting only a few rats. The commission found in two Punjab villages that cases of chronic plague abscess in rats occurred at intervals all the year round. Whether such cases might be able to rekindle an epizootic of acute plague is not clear, and seems to demand further experiment.

With regard to the spread of infection during an epidemic, the Queensland report gives us valuable data. Mr. Burnett Ham, dealing with small epidemics, and a population more amenable than that of Bombay to sanitary regulation, was able to trace definitely the source of infection in a large majority of cases to houses, stores, or ships where the presence of infected rats was proved. An exceptional occurrence was the outbreak of pneumonic plague in Maryborough in 1905. The infection in this instance spread directly from patient to patient; nine cases occurred.

The seasonal exacerbation of plague remains unaccounted for. In Queensland and in Bombay, in opposite hemispheres, the plague-seasons still broadly coincide, though the plague-maxima in Queensland varied considerably—from February to August—in different years. A study of the figures given for the variations in the flea-infestation of rats does not reveal a complete explanation of the phenomenon. For instance, the Punjab experiments show that fleas

become frequent months before the plague season begins. Fleas were actually on the decrease when rat-plague was rising to its maximum in Kasel and Dhand. Nor can we suppose that the temperature in Bombay in the cold season is low enough to keep plague in abeyance until the spring. We learn from the reports that the mean temperature of Bombay for the cold season is about 75° F., and a glance at the chart, which gives meteorological data in connection with the Queensland epidemics, shows that plague may appear, spread, and maintain itself under a mean temperature varying between 50° and 70° F. The Queensland report, in addition to epidemiological data, gives a large amount of clinical information, and experiments on the prophylactic and curative value of anti-pest sera. Experiments with rat-viruses carefully maintained at high virulence gave results more encouraging in the laboratory than in the field.

Major G. Lamb is responsible for the third volume under notice, and he has used the opportunity to give us a very clear outline of the present state of knowledge on the subject of plague. He also indicates the lines along which sanitary measures may be taken with advantage. While stating that this summary represents his personal opinions, he shows how these opinions arise logically out of the experiments carried out by the commission.

The lacunæ in our knowledge are brought into a healthy prominence by a summary of this nature. We do not yet possess trustworthy information as to rat population (part ii. B.), while our only means of taking a census is that of recording the percentage number of rats caught per traps set. One thing is pretty clear—that the most efficient trapping will never of itself reduce the rats of any considerable area below the minimum necessary for the spread of an epizootic.

Part iii. disposes of transmission of infection by direct contact, by the air, by food, or through the soil, and gives the proofs for transmission by the rat-flea. Direct contagion certainly occurs in pneumonic plague, but this is so rare as to fall outside the main problem.

Though man plays a minor rôle in the spread of an epidemic (part iv.), yet he is directly concerned in the importation of the disease into healthy areas (part vii.). It has been shown that hungry rat-fleas will cling to man and yet refrain from feeding for a considerable time. The man in the meantime may have travelled some distance and have arrived at a house where rats are abundant. His guests will then leave him for their natural hosts, and thus the rats may become infected while the man remains healthy.

At the end of the plague season in any locality plague may die out completely, or the epizootic may continue at a low level through the off-season. In the latter case the locality becomes a focus from which infection will be spread; with the arrival of the next plague season, over the surrounding country. Thus rats with acute plague are caught in Bombay all the year round.

The sum of these investigations may perhaps be expressed as follows. Extinction of rats, extinction of fleas, or exclusion of rats from dwellings might any one of them put an end to human plague, but all are exceedingly difficult to realise. On the other hand, the conditions which determine the off-plague season are not fully known, and may still give an indication of some practicable method of fighting the disease. Further investigation is urgently demanded.

L. N.

NOTES.

ACCORDING to the *Pioneer Mail*, the provision of a Pasteur Institute for Burma is now assured, but some little time must elapse before the work can be started. The local community has come forward liberally in subscribing nearly a lakh of rupees, and the Government of India is understood to be addressing the Burma Administration on the subject of the ways and means for carrying the scheme into effect, the total cost of such an institution being, of course, much in excess of the sum that has been raised.

At the sixth annual meeting of the Association of Economic Biologists, held at University College, London, on April 15, Mr. A. E. Shipley, F.R.S., was elected president for 1908. A summary of the scientific proceedings appears among our reports of societies. The following resolution was passed at the meeting:—"That this association, recognising the great need of an organised inquiry into the feeding habits of the birds of the British Isles with the view of obtaining a practical knowledge of their economic status, is of the opinion that a committee should be formed with the object of carrying on investigations on this subject."

On Tuesday next, April 28, Mr. Gerald Stoney will begin a course of two lectures at the Royal Institution on "The Development of the Modern Turbine and its Application"; on Thursday, April 30, Mr. W. Bateson will commence a course of three lectures on "Mendelian Heredity" (these are the Tyndall lectures); and on Saturday, May 2, Mr. G. F. Scott Elliot will deliver the first of two lectures on "Chile and the Chilians." The Friday evening discourse on May 1 will be delivered by Prof. Joseph Larmor, on "The Scientific Work of Lord Kelvin"; on May 8 by Mr. J. Y. Buchanan, on "Ice and its Natural History"; and on May 15 by Mr. Herbert Timbrell Bulstrode, on "The Past and Future of Tuberculosis."

At the London Institution on April 15, Mr. Valdemar Poulsen lectured on "Telephoning without Wires." The paper was translated and read to the audience, and showed that Mr. Poulsen has made a great advance in radio-telephony since his last lecture in London at the Queen's Hall two years ago. The progress made in wireless telephony is shown by the fact that conversation has been carried on across Denmark from Lyngby to another wireless telephone exchange at Esberg, 170 miles distant. The reproduction of the voice was clear and distinct, and easy to recognise. In addition to this, a further trial was made with a phonograph played in Berlin, the music of which was heard distinctly at Lyngby, near Copenhagen, 290 miles distant. At the close of the lecture some experiments with a phonograph were made, and the strains of two pieces of music were radiated to a telephone box in the roof of the building, whence the audience were enabled to hear the reproduction through telephone receivers. Mr. Poulsen showed an apparatus which was guaranteed to receive wireless messages in the Morse code, telephone cables, and wireless photographs. The wireless photographs are produced by the deflection of a recorder for the fraction of a second by wireless impulse. A ray of light shines on a photographic plate, and consequently a photographic negative of easily read signals is produced. Mr. Poulsen has also produced a practical transmitter of such a size that it can easily be carried in baggage, and thus enables an officer on sea or land to communicate with other units in his own voice.

MR. J. R. PENNELL, Mr. A. KINNES, and Mr. H. C. BOOTH have been appointed to the vacant junior assistantships in the National Physical Laboratory.

SOME months ago we had occasion to notice a paper by Mr. G. R. MARRINER on the habits of the New Zealand kea parrot. A volume by the same observer, entitled "The Kea: a New Zealand Problem," is now announced by Messrs. MARRINER and SPENCER, of Christchurch, N.Z.

WE have to acknowledge the receipt of two parts (vol. xi., part ii., and vol. xii., part i.) of the Transactions of the Leicester Literary and Philosophical Society. In the latter of these, special interest attaches to a paper by Mr. T. O. BOSWORTH on the origin and mode of deposit of the Upper Keuper beds of the county. In this paper, which was read at the Leicester meeting of the British Association, the author points out that the climate of the Carboniferous epoch, like that of the present day, had a highly disintegrating effect on the igneous rocks of Charnwood Forest. Where, however, the Charnwood rocks have been buried under Keuper deposits, they present a sharp, uneroded surface, indicating the existence of dry desert conditions at the date of deposition of the latter.

IN the February issue of the *Bulletin international* of the Academy of Sciences of Cracow, Mr. K. STOLYHWO describes a human skull dating from the historic period which presents strong indications of close affinity with the Spy-Neanderthal type, the so-called *Homo primigenius*, of the Palaeolithic epoch. The skull, it appears, formed part of a skeleton from a tomb in which was also buried a suit of chain-armour, together with iron spear-heads, &c. In the great development of the supra-orbital ridges and of the notch at the root of the nasals, the skull, which was found at Nowosiolka, closely approximates to the Neanderthal type. It may be added that, in view of Prof. SOLLAS's recent reference of the latter to the Australian stock, the occurrence in eastern Europe of a late survival of the same type is a matter of profound interest.

THE Indian Forest Department has decided to issue two new serials, *Indian Forest Records* and *Indian Forest Memoirs*, for the publication of departmental literature. The first part of the *Records*, published in Calcutta in January, is devoted to an elaborate account, by Mr. E. P. STEBBING, entomologist to the department, of the lac-insect and its product. Although the exports of lac from India are of immense value, amounting in 1905-6 to more than three crores of rupees, a comparatively small revenue is yielded to the Forest Department from this source, and one of the objects of the inquiry was to ascertain whether matters could not be put on a more satisfactory footing in this respect. The inquiry also related to possible improvements in the methods of collecting the lac. The account is illustrated with two plates, one devoted to the life-history of the insect and the other to the mode of formation of the lac. It is unfortunate that, on its first page, the part bears the date of 1907 instead of 1908.

INSECTS injurious to the valuable sal-forests of Assam, together with the parasites and other insects by which they are infested or attacked, form the subject of an article by Mr. STEBBING, issued at Calcutta as *Forest Bulletin* No. 11. It has long been known that these forests are subject to severe damage from the attacks of leaf-eating caterpillars, but Mr. Stebbing considered it probable that the chief harm would be found due to a longicorn beetle akin to the one attacking sal-timber in central India. Unfortunately, this suggestion has proved only too true,

great damage being caused to the Assam timber-supply by the species (*Hoplocerambyx spinicornis*) so harmful to the forests of Chutia Nagpur.

THE report for the year 1906, prepared by Mr. J. H. Maiden, appertaining to the botanic gardens and Government domains in Sydney, has been received. A list of groups of plants specially interesting to students is provided, and the situations in which they may be found. The successful novelties introduced to the gardens include *Fagus sylvatica*, var. *heterophylla*, *Physostegia virginiana*, *Cassia occidentalis*, known as Negro Coffee, the indigenous species *Angophora cordifolia* and *Cheiranthra linearis*, and some West Australian shrubs.

DR. C. HOSSEUS communicates to *Engler's Botanische Jahrbücher* (vol. xl., part iv.) an account of the vegetation observed on Doi Sutap, a mountain situated in the Shan States attached to Siam. Ascending from the rice fields, a light wood of teak and Albizzia, carpeted with composites and léguminous plants, was first reached. The "Hill Eng" forest, composed of species of Dipterocarpus and allied genera, on which numerous epiphytes grow, began at an elevation of 1000 feet. After ascending 2000 feet higher a forest of *Pinus khayana* was found, giving place to bamboo vegetation at 4000 feet. In this zone the new genus of the order Rafflesiaceae, *Richthofenia siamensis*, was discovered; several new species were also found near and between the summits.

IT is usual to associate Montserrat with the production of limes, so that it occasions some surprise to read in the annual report for 1906-7 of the botanical establishments on that island that cotton promises to become the most important industry. In the space of four years there has been a significant increase in the amount and value of the cotton exported. At the same time, the distribution list of the botanic station furnishes evidence of a considerable demand for limes, in addition to which cacao and Castilloa rubber trees have been in request. An introduced industry, in the shape of onions grown from Teneriffe seed, shows a remarkable development within the year, and it is stated that further expansion is only prevented by the limited shipping facilities.

AN article by Mr. A. Maumerné on Japanese dwarf trees, their forms and cultivation, is published in the Journal of the Royal Horticultural Society (vol. xxxii., part i.). There are definite æsthetic canons regulating the forms and outlines that are produced. Many of the artistic effects are due to training of the branches, others to special development of the roots. Conifers are the favourite plants for working on, especially species of *Thuja* and *Pinus*. Grafting is frequently practised with species of *Podocarpus* and maples. In the same volume will be found a useful article on horticultural law, by Mr. H. M. Veitch, in which he discusses such points as rights with regard to overhanging trees, fixtures, and trespassers. An annotated list of Gesneraceæ is contributed by Colonel H. Beddome.

MESSRS. CONSTABLE AND CO. have just commenced the publication of a new monthly magazine—*The Country Home*—the scope of which is sufficiently conveyed in the title. Descriptions of artistic and famous country houses are provided in the accounts of Stoke D'Abernon Manor House and of several black-and-white timbered houses in Cheshire and adjacent counties. There is a sprinkling of natural history in various articles. Mr. F. Moore contributes an excellent article on the making of lawns, and

one may expect useful hints on intensive cultivation in the legend of the gardener and the cook, told by Miss L. Yates. Mr. J. W. Odell writes the monthly notes on the garden and greenhouse. In extending a welcome to this new venture, which is attractively got up and well printed, it may be hinted that, possibly for the sake of variety, several of the articles are too short to arouse much interest.

"A CATALOGUE of the Library of Charles Darwin now in the Botany School, Cambridge," has been compiled by Mr. H. W. Rutherford, of the University library, and published by the Cambridge University Press. Mr. Francis Darwin has contributed an introduction, in which he gives interesting information, supplementary to the account contained in the "Life and Letters," concerning his father's methods of work and treatment of books. The collection of books now bequeathed to the University is not identical with that at Down; thus, the books Darwin wrote and some few others from Down remain in the possession of Mr. Francis Darwin. Darwin's pamphlets are not included in the catalogue, though part of them are on the shelves alongside his books. The introduction points out that Darwin hardly ever had a book bound, and the collection retains to a great degree its original ragged appearance. The general characteristic of the library is incompleteness, hardly any set of periodicals being perfect. The chief interest of the Darwin books lies in the pencil notes scribbled on their pages, or written on scraps of paper and pinned to the last page. Books are also to be found marked with a cypher, as described in "Life and Letters." Mr. Francis Darwin provides many facts of interest in connection with some of the more important books included in the library. In a preface, Prof. Seward expresses to Mr. Darwin the high appreciation of the botany school and University for rendering the library available to all students. The price of the catalogue is 1s. net.

IN the *Engineering Magazine* for April, Mr. Jacques Boyer gives an illustrated description of the rescue appliances used in the French collieries, special attention being given to the Tissot respirator, which dates from 1907, and the Vanginot respirator, which has been in service for several years in the Paris Fire Department, and is coming into increasing use in the French collieries.

BULLETIN No. 250 of the Michigan State Agricultural College contains a full description, with plans and illustrations from photographs, of the new college farm buildings recently erected at a cost of 15,000 dollars, of which 10,000 dollars was granted by the Michigan State Legislature. The buildings are designed solely for ordinary farm purposes, and not for special experiments, and the bulletin is issued with the idea of furnishing farmers with plans of buildings considered suitable for the local requirements.

AT the Institution of Mechanical Engineers on April 10, Prof. Bertram Hopkinson read a paper on the effect of mixture strength and scavenging upon thermal efficiency. The method used for measuring the gas, described in the author's previous paper on the mechanical efficiency of a forty brake-horse-power Crossley gas-engine, was especially advantageous, for it gave the actual volume of gas used in the series of forty or fifty explosions from which the indicator diagrams were taken, and the materials for a complete measurement could thus be obtained in a few minutes. Diagrams with three or four different gas-consumptions could be got within an hour, during which

time the calorific value of the gas would remain constant, so that the effect of changing the strength of mixture or of scavenging by running without load could be very accurately determined. When allowance is made for the gas discharged unburnt, the efficiency is not much affected by scavenging provided the strength of mixture is kept the same, which implies an increase of about 15 per cent. in the gas-charge, with, of course, a corresponding increase of mean pressure. At the same meeting Mr. James Atkinson read a paper on the governing and regularity of gas-engines, in which the various methods of governing employed were critically discussed.

THE report of the Observatory Committee of the Royal Cornwall Polytechnic Society for the year 1907 has been received. The Falmouth Observatory is one of the important meteorological establishments subsidised by the London Meteorological Committee for the tabulation of automatic records; it has a complete magnetic equipment, and during the year in question received material assistance from the Royal Society towards the maintenance of this branch of its useful work. The observations fairly represent the conditions in the west of England; the mean temperature of 1907 was $0^{\circ}.4$ below, and the rainfall 2.78 inches above, the mean. During a brilliant display of aurora, on February 9, the magnetographs showed that a storm of great intensity was in progress.

THE Stonyhurst College Observatory (Lancashire), which has likewise sent us a copy of the results for 1907, also receives some allowance from the Meteorological Office. Its records (together with those of the Liverpool Observatory) represent the meteorological conditions in the north-west district of England, and it possesses a valuable series of observations extending over sixty years. The rainfall of the year was 3 inches above, and the temperature $0^{\circ}.6$ below, the average. Magnetic observations are carefully recorded, but the staff is too limited to undertake hourly tabulations from the curves. Some 198 drawings of sun-spots and faculae were made, and Father Sidgreaves remarks on an unexpected revival of solar activity and magnetic disturbance.

THE Royal Geographical Society has published a "Bibliography of Topographical and Geological Works on the Phlegrean Fields," by Mr. R. T. Günther, containing about 2200 titles of books, papers in scientific and other periodicals, maps, and drawings, relating to the city of Naples and the country to the west of it, together with the volcanic islands in the vicinity. The catalogue is specifically restricted to the geomorphology, topography, and physical features of the region, and is arranged as a subject catalogue, the entries being grouped in topographical sections or sections devoted to special subjects, and printed in each group consecutively in order of date of publication. When supplemented, as in this case, by an index of authors and subjects, no more convenient arrangement could be devised. The catalogue will be of great service to students of volcanic and kindred phenomena, and to others interested in the region dealt with, but the reference to geology in the title might well have been omitted, for the list is by no means complete in this department; we notice the inclusion of papers which have no real bearing on the subjects to which the bibliography is restricted, and the omission of others which should have been included.

THE March number of the *Psychological Review* contains the second of two interesting articles, by Dr. Boris Sidis, setting forth a new explanation of hallucinations.

It is based upon a novel theory of perception, the exposition of which was contained in the former article. The perception of an object involves, as is well known, a reference to other sense qualities of the object than those immediately presented. Thus we may "see," not only the transparency, smoothness, and whiteness of a lump of ice, but also its coldness and weight. Former doctrines of perception have regarded the latter factors of the perceptual complex as images; in opposition to this view Dr. Sidis maintains that, like the former, they are sensational. He distinguishes them from the sensational elements the material causes of which actually affect the sense organs, by calling the latter "primary" and the former "secondary sensory elements." In normal perception we have a group containing elements of both types organised round a nucleus of primary elements, but under abnormal conditions it may happen that the primary sensory elements become subconscious or fall entirely out of the patient's consciousness, leaving a group of secondary sensory elements standing as an independent synthesised compound. Such a dissociated group of secondary sensory elements constitutes an hallucination.

DR M. MARAGE described before the Paris Academy of Sciences a method invented by him of photographing the vibrations of a thin india-rubber membrane when acted on by the tones of the human voice. A small mirror is attached to the membrane, and a beam of light is reflected from it upon a band of sensitised paper slowly moved by a small electromotor. After receiving the impression the photographic paper is drawn by the motor through two developing baths, and finally into a fixing bath. There is nothing strikingly novel in the method, and the examples of the tracings given in the paper published in the *Comptes rendus* of the academy do not seem to be clear or to give much information.

MR. J. W. GILTAY, of Delft, Holland, has sent us a descriptive catalogue of apparatus for demonstrating the action of light on selenium. The selenium cells listed are of the Shelford Bidwell type, their resistance in the dark ranging from 25,000 ohms to 500,000 ohms. Low resistance and high sensitiveness, it is noted, do not go together. These cells have been manufactured by Mr. Giltay ever since 1881, and among those to whom they have been supplied is Dr. Korn, who uses them in his well-known process of telegraphic photography. Their capabilities in this direction are demonstrated by a reproduction of an excellent portrait of Dr. Korn, which was transmitted electrically. Among other apparatus described is a miniature photophone. Words spoken into the mouth-piece of the transmitter act upon an acetylene manometric flame, which illuminates a selenium cell placed near it; the cell is connected in circuit with a battery and a telephone receiver in a distant room, and the speaker's voice is heard at the telephone. Several modifications of this apparatus are described. A compact battery of forty-nine cells, providing the high electromotive force requisite for experiments with selenium, is supplied at a moderate price.

Le Radium for March contains an account of the work done recently by M. A. Dufour on the effect of pressure on the wave-lengths of the absorption lines of nitrogen peroxide and bromine. The observations made hitherto on the effect of pressure on emission spectra have led to the conclusion that the lines of bands were unaffected. M. Dufour finds, on the contrary, that certain lines of the absorption spectra of the two vapours mentioned are influenced by pressures up to about 20 atmospheres. The whole of the lines of the absorption bands are broadened

and rendered less sharp, but certain lines are unaltered in wave-length, while others increase by amounts of the order of a few hundredths of an Angström unit per atmosphere increase of pressure. There seems to be no connection between the influence of pressure on the wave-length and the Zeeman effect in the case of bromine, although there may possibly be such a connection in the case of nitrogen peroxide.

SOLUTIONS of the examples in "A Sequel to Elementary Geometry," by Mr. J. W. Russell, which was reviewed in the issue of NATURE for February 6 last (vol. lxxvii., p. 315), have been prepared by the author, and published at the Clarendon Press, Oxford. The price of this key is 3s. 6d. net.

OUR ASTRONOMICAL COLUMN.

STRUCTURE OF THE CORONA.—In No. 19, vol. ii., of the *Mitteilungen der Nikolai-Hauptsternwarte zu Pulkowo*, Prof. Hansky discusses the results derived from a study of the photographs of the corona taken by the Pulkowa expedition at Alcobcère (Spain) during the total solar eclipse of August, 1905. The principal aim of the photographs was to determine the velocity of the propagation of coronal matter in space, and the eight exposures were therefore arranged symmetrically about mid-eclipse, and given approximately equal times.

Each streamer and prominence shown on the photographs is discussed very fully, and Prof. Hansky finally draws the following conclusions. The corona of 1905 was of the "maximum" type, and was divided into eight groups of streamers, arranged symmetrically about the sun's axis. It appears probable that the forms and directions of the coronal streamers depend upon the forms and directions of the prominences above which they are found. In this conclusion Prof. Hansky's result agrees with that recently published by Dr. W. J. S. Lockyer (see NATURE, No. 2005, p. 514). The centres of emission of the streamers, though often near spots, do not coincide with them. Those streamers which occur over great prominences are readily distinguishable by their forms. The jets of prominences resemble jets of matter, the observed velocity of which approximates to 200 km. per sec. Any movement of coronal clouds above prominences is shown to be very slow, its velocity not exceeding 30 km. per sec.; this is so small that any such movement during the three minutes of totality would not produce a change of position sufficiently great to exceed the limits of observational errors.

SPECTROSCOPIC BINARIES NOW UNDER OBSERVATION.—With the view of assisting in the prevention of unnecessary duplication in the observation of spectroscopic binaries, Prof. Frost, director of the Yerkes Observatory, recently addressed a circular letter to the principal observers in this work asking them to furnish him, for publication in the *Astrophysical Journal*, with a list of the objects now under observation at the several institutions. The various replies appear in No. 2, vol. xxvii., of the journal (p. 161), and show that duplicate observations are already in progress. Prof. Hartmann points out, whilst furnishing a list of stars, that duplication is not necessarily an evil, for, with the determination of radial velocities still in a state of evolution, such duplication serves as an independent check on the various results. Prof. Pickering suggests several pieces of work where cooperation would probably lead to useful results, and points out that, even with an objective-prism spectrograph, the star ζ Ursæ Majoris shows marked irregularities in its spectrum which have not yet been accounted for.

THE RELATION BETWEEN THE COLOURS AND PERIODS OF VARIABLE STARS.—In an interesting paper which appears in No. 4238 of the *Astronomische Nachrichten* (p. 209, March 9), Herr S. Beljawsky, Göttingen, discusses at some length the relation found to exist between the colours and the periods of variable stars. From the tables and curves given in the paper it is seen that in general the

variable stars of long period are much redder than the short-period variables. Regarding the amplitudes of the typical light-curves, it is found that up to periods of 200 days the amplitude increases with the period, beyond 200 days it appears to remain constant.

A FIELD METHOD OF DETERMINING LONGITUDES.—Paper No. 5 of the Egyptian Survey Department is devoted to an explanation, by Mr. E. B. H. Wade, of an instrument designed by him for making field determinations of longitude by observations of the moon. By a system of mirrors placed at the object-glass end of a small 24-inch telescope, Mr. Wade successively brings the images of two stars in contact, tangentially, with the limb of the moon, thus finding the times of equal lunar distance. The apparatus is ingeniously designed, and is readily portable. Full explanations of the instrument and the method are given in the paper, which is illustrated by a number of diagrams and curves.

OBSERVATIONS OF EROS.—The results of ten measures of the position of Eros, made with the 15-inch refractor of the Uccle Observatory during the period September 25 to October 19, 1907, are published in No. 4240 of the *Astronomische Nachrichten* (p. 252, March 23) by Herr G. Van Biesbroeck. Comparing the positions thus determined with those given in the ephemeris published in the "Berliner Jahrbuch" for 1909, it is seen that the mean corrections to the latter are -1.108 in R.A. and $-8''.0$ in declination.

VARIABLE RADIAL VELOCITY OF η VIRGINIS.—A note in No. 2, vol. xxvii., of the *Astrophysical Journal* (p. 161, March) gives the provisional elements of the orbit of the brighter component of η Virginis, as determined at the Ottawa Observatory by Mr. W. E. Harper. The period is found to be 71.9 days, the velocity of the system $+2.2$ km. per sec., the eccentricity of the orbit 0.4, and the length of the semi-major axis 25,750,000 km. The velocity-curve shows a variation from -40 km. to $+20$ km.

AGRICULTURAL EXPERIMENTS AND REPORTS.

THE eighth report of the Woburn Experimental Fruit

Farm contains a very valuable investigation of the washes commonly used for spraying fruit trees. They have hitherto been made up in rather a haphazard way, without much reference to the chemical changes involved, and Mr. Pickering is to be congratulated on having reduced them to a scientific basis. He shows that Bordeaux mixture (obtained by precipitating copper sulphate solution with lime) made in the ordinary way consists of



but this is not so economical as another precipitate, $4\text{CuO}, \text{SO}_3$, for obtaining which full instructions are given. An investigation of the "Woburn wash" (paraffin emulsion and caustic soda) led to a very important examination of emulsions in general, which has enabled Mr. Pickering to state the conditions under which they may be expected to form. When oil is churned with water it is broken up into very minute particles; if still smaller particles of an insoluble substance are present they coat the oil drops and prevent them from coalescing; an emulsion is therefore formed. During the progress of this work Mr. Pickering discovered a new emulsion which promises to be of great service to the fruit-grower. Basic copper sulphate (obtained by adding lime to ordinary copper sulphate) was churned with oil and water, and gave a perfect emulsion to which caustic soda could be added without any adverse effect. The result is a wash containing the three things which have to be used in winter and spring; the grower can therefore get them all on in one operation instead of in three as hitherto. The insecticidal and fungicidal action of these and other washes was also investigated, and there is a discussion of the nature of the action of insecticides.

Of late years molasses has been increasingly used as cattle food, and various agricultural stations have investigated its digestibility and nutritive value. A Bulletin

recently issued by the Massachusetts Experiment Station (No. 118) gives the results of experiments by Lindsey, Holland, and Smith. They found that any large quantity of molasses depresses the digestibility of the other constituents of the ration; this is known to be the general effect of too much carbohydrate. Molasses proved less economical than ordinary farm foods; it proved, however, a valuable condiment, and induced the animals to eat unpalatable and inferior fodder which otherwise they would have refused. It was also found to keep the animals in good condition. Two or three pounds a day is recommended as the proper allowance for cows and horses.

In a paper recently read before the Canterbury Farmers' Club, Mr. E. S. Salmon gives the history of the Gooseberry Mildew Order of July, 1907. This was the first order issued by the Board of Agriculture under the new Destructive Insect and Pest Act, an Act largely due to Mr. Salmon's tireless exertions on behalf of fruit-growers. By the terms of the order the gooseberry mildew is a notifiable disease under a penalty not exceeding ten pounds; the local authority, on receiving notice of its existence, is required to make the grower destroy immediately all diseased bushes, and then spray with an approved fungicide all surrounding bushes. The payment of compensation for the destroyed bushes is optional on the part of the local authority, but the necessary money must be provided out of the rates, as no Treasury grant is available. Mr. Salmon states that the order is not being carried out, and that there has been no systematic destruction of diseased bushes, because the councils have been unwilling to destroy bushes without compensation, and afraid to draw the necessary money from the rates. The result has been that the disease is spreading rapidly, and is now known in six counties. Instead of strengthening the order the Board has practically nullified it by issuing a second one permitting the grower to prune instead of burn his bushes. Mr. Salmon criticises the order strongly, and points out that pruning cannot keep the mildew in check. He goes on to say:—"The Board of Agriculture, without any scientific leadership, have again temporised at the most critical stage. There is now but one opportunity remaining of dealing with the American gooseberry mildew and preventing it sweeping through the country, and that is to deal with the disease this winter, but it must be by thorough and uncompromising measures." He recommends systematic destruction of every infected bush in the country, compensation to be awarded out of the Treasury. If this is not done, he thinks gooseberry growing will cease to be a commercial possibility in England.

A pamphlet has recently been issued by Mr. E. S. Salmon on the "black scab" or "wart disease" of potatoes (*Chrysophyctis endobiotica*, Schilb.). This dangerous disease, which came over from the Continent about 1895, now occurs in nine counties in England and Scotland, and seems likely to spread throughout the country unless drastic preventive measures are taken. The fungus attacks the growing potatoes, causing the formation of wrinkled, warty excrescences which may become even larger than the actual potato itself; sometimes the stem and leaves are similarly attacked. Spores can remain in the ground for two years at least, and there is evidence that they can remain dormant for six years. Mr. Salmon urges the desirability of bringing this disease under the Destructive Insect and Pest Act. It would certainly seem desirable that the Board of Agriculture should have expert guidance in connection with this new Act, so that diseases could be brought within its scope directly they appear, instead of waiting until considerable damage has been done.

The *Agricultural Journal of the Cape of Good Hope* for January contains an account of the Kafr corn aphid (*Aphis sorghii*), an aphid which, as its name implies, badly attacks Kafr corn (*Sorghum vulgare*). It is stated that the pest is spreading, and is likely to be a serious matter in the near future owing to the great value of Kafr corn in Cape Colony; a thorough field study is desirable during January, February, and March, when the insect is on the corn. The same number also contains an article by W. Robertson on preventive inoculation of farm stock, dealing specially with lung sickness, anthrax, and black quarter.

The *Agricultural Journal of India* (October, 1907) contains several articles of interest to the large Indian agriculturist. The similarity between the conditions obtaining in Sind and in Upper Egypt is pointed out, a similarity which has enabled Egyptian cotton to be successfully grown where previously none could be obtained. Mr. Maxwell-Lefroy contributes a useful article on practical remedies for insect pests, and there is a good account, with illustrations, of the stock on the Government cattle farm at Hissar (Punjab).

Owing to the large number of new orchards coming into bearing in South Australia, the production of fruit is likely considerably to exceed the local demand; a detailed account of the process of fruit-drying is therefore given in the *Journal of Agriculture of South Australia* (December, 1907). The fruits dealt with are apricots and prunes; the instructions are very full, and should prove valuable to the fruit-grower. Another article deals with the banded pumpkin beetle (*Aulophora hilaris*, Boisd.), which does considerable damage to melons.

The December (1907) number of the *Agricultural Journal of the Cape of Good Hope* contains an article by Mr. Lounsbury on the Plasmopora vine disease in Algeria, in which attention is directed to the similarity between Algeria and Cape conditions. No remedy for the disease is known, and the Cape authorities are naturally anxious that they may remain free from it. There is also a report on various methods tried for the destruction of the prickly pear. This tree spreads rapidly on ground which is not being actually cultivated, and is found seriously to injure the ground for cultivation. The best and simplest method found was to cut down the tree, spray the heaps with sodium arsenite solution, and then inject a 10 per cent. solution of the same salt into the stumps still left in the ground. This journal adopts the very useful plan of publishing the lectures given at the Rhodes University College during the vacation courses in agriculture, by which means they are made known to a much wider circle than would otherwise be possible. All the lectures deal with important agricultural problems. In the present number the breeding and grazing of Angora goats is gone into at length; there are also two articles on the management of ostriches.

We have received three leaflets from the Board of Agriculture, No. 195 dealing with the American gooseberry mildew, No. 199 with the pine disease, and No. 202 with the frit fly. The pine disease is caused by *Diplodia pinea*, Kickx., a wound parasite, the mycelium of which extends rapidly towards the tip of the shoot and takes up the food supply. After a short time all the leaves fall and the plant dies. The frit fly (*Oscinis frit*) is stated to be one of the chief cereal pests in Europe; the chief damage in Great Britain is to oats, and there are Continental records of attacks on barley, wheat, rye, maize, and various grasses. It appears that early sown crops are less liable to be attacked than late sown.

In the January number of the *Journal of the Department of Agriculture and Technical Instruction for Ireland* there is a full report of the first address by the new vice-president to the council, which affords eloquent testimony to the value of the work done by Sir Horace Plunkett. Itinerant instructors are now at work in every county; in addition, winter classes are held in thirteen counties at thirty-two centres, the number of pupils attending being estimated at five hundred. Twenty-six students are training at the Royal College of Science for teaching appointments, fifty-seven are studying at Glasnevin with the view of actual farming, and there are also three smaller institutions with fifty-nine students between them. The prosperity of the country is increasing; the export of eggs increases rapidly, and is now valued at 2,500,000.; poultry are also being sent out in greater number and of better quality. Schemes are on foot to study the production of winter butter, to increase the forest land, to set up cattle dispensaries in certain counties, and to push the sale of Irish produce in the English markets. All this is excellent; we cannot, however, help feeling more than doubtful about another plan suggested for the future—of choosing Irishmen by preference for teaching posts. It would surely be much better to choose the best available man, quite regardless of his nationality.

RECENT EARTHQUAKES.¹

UNTIL recent years the attitude of the ordinary Englishman with regard to earthquakes has been one of apathy. He argued that, although every year 30,000 earthquakes might occur in the world, his country only contributed about half a dozen, and these, because they were so small, did more to excite curiosity than to create alarm. Although in 1883 Colchester, and in 1896 Hereford, lost a few chimney pots, and buildings were unroofed, also at intervals, reckoned by one or two hundred years, London has been shaken, still England could not be regarded as an earthquake-producing country. British-made earthquakes may be of rare occurrence, but should there be any relief of seismic strain similar to that of 1883 or 1896 in the synclinal on which our great metropolis stands, we might find as many chimney pots in the streets as there are inhabitants. A suggestion of this kind, however, does not disturb the mind of our ordinary English-

man but also in Europe and Asia, have by recent earthquakes been reduced to heaps of debris. When these are reconstructed, it is extremely likely that the well-tested rules and methods, the outcome of applied seismology, will not be neglected.

Seismological investigations have been made, not only for scientific reasons, but to minimise the loss of life and property. In connection with the destruction of San Francisco alone, we are told that British insurance companies are called upon to meet claims amounting to 12,000,000*l.*, while losses of like character may have to be met in other parts of the world. The Englishman living on his own little patch of *terra firma* is continually paying for earthquake effects all over the world. The thinking man now realises that insurance rates in many countries must vary with the seismicity of a district, together with the character of the structures to which they refer. Sub-oceanic seismic activity frequently results in the failure of cables. It is therefore of extreme importance that the

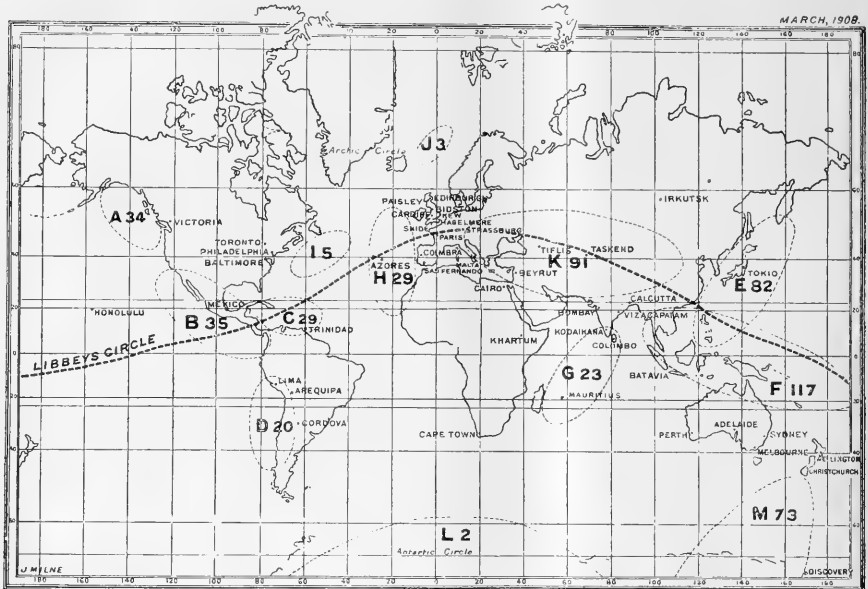

FIG. 1.—Stations in cooperation with the British Association working with similar instruments (Milne pendulum). Number of world-shaking earthquakes since 1899 which have originated in districts marked A, B, C, &c., are indicated.

man. Hints respecting the possible instability of his country produce no effect, and he fails to see why he or his Government should be called upon to support seismological investigations. Recent earthquakes have, however, modified his opinion, and although England may be free from earthquakes, he finds, he has to insure against and pay for the effects which these disturbances have caused in distant places. By observations on what has stood and what has been destroyed after violent shakings of the ground, and as the result of investigations together with elaborate and costly experiments carried out entirely in Japan, not only have new methods of construction been formulated, but these have had extensive applications. Experience has shown that the new types of buildings stand whilst the old ones are shattered. At the present moment, Valparaiso, San Francisco, Kingston, and very many other cities, towns, and villages, not only in America,

¹ Discourse delivered at the Royal Institution on Friday, March 20, by Prof. J. Milne, F.R.S.

sites of these submarine disturbances should be located (see map). In these and in many other ways it is easy to show that England has probably a greater practical interest in the results of seismological investigation than any other country. Finance and earthquake effects are close relations. Another incentive to the removal of apathy in regard to seismology lies in the fact that the mind of the public, like that of the individual, becomes fatigued by repetition. What is asked for is something new, and, if possible, it should be sensational. Newspapers and magazines do all they can to relieve this craving, with the result that the public is liberally supplied with stories about big catastrophes and deductions based thereon. A new *hors d'oeuvre* has been added to the daily scientific menu, and the halfpenny paper and the sixpenny magazines have given a stimulus to investigations bearing upon earth physics.

In countries where earthquakes have been severe, and where by their frequency they are continually forcing them-

selves upon public attention, a desire to investigate is furnished by the earth itself. Chili is now arranging to have a system of observing stations. Jamaica is speaking about the same, whilst the United States are extending what they now possess. Three recent earthquakes have awakened three different Governments to the fact that, although schoolmasters may not flog their children, nature is not always as indulgent to its people. Japan, in addition to establishing stations in Formosa, Saghalin, China, and Korea, has already more than 1000 observing stations, 120 of which have instruments for recording local shocks.

For seismological investigations the Government of that country annually allocates 1000*l.* to 5000*l.*, and this is outside expenditure in connection with the chair of seismology, and concomitant with investigations of earthquakes in foreign countries. During the last ten or twelve years Japan has issued about seventy quarto volumes bearing upon seismological investigations. Russia has a series of well-equipped stations within its borders. For very many years Italy has given great attention to the movements of the ground. These are recorded at several hundreds of stations, 160 of which are provided with instruments. Austria, Germany, and many other States are also devoting great attention particularly to the collection of earthquake statistics. I fail, however, to see that these statistics, which are necessarily imperfect, will pass beyond the borderland of local interest. So far as I am aware, all foreign stations are subsidised by their respective Governments. Great Britain enjoys the cooperation of forty-five stations provided with similar instruments, which are distributed fairly evenly over the four quarters of the world. The names and positions of these stations are shown upon the accompanying map (Fig. 1). The home stations are supported by the British Association, the Royal Society, the *Daily Mail*, Mr. M. H. Gray, and other private individuals. So far as the recording of world-shaking earthquakes is concerned, I believe the British cooperation to be, at the present time, quite equal to a combination of the stations of all other countries. The last outcome in connection with observational seismology has been the establishment of an International Seismological Association. The central bureau is in Strassburg, and its president is Prof. A. Schuster, and its general meetings take place once every four years. I am not aware that France has formally announced its adherence. The British Government, by subscribing 160*l.* a year to the central bureau, has accepted a shelter from a Continental régime. For nearly fifty years the British Association has encouraged seismological research, but whatever prestige it may have gained, together with its attendant commercial and other advantages, these are passing under a new régime across the Channel.

A Government of a country does not wish to seek abroad for an explanation why telegraphic messages have ceased to flow. To confirm, extend, or disprove a cablegram, a Government, a business house, or the public of a given country would like to obtain information within its own boundaries. When a country or a colony finds itself cut off from the outside world in consequence of cable interruption, that country or colony, together with other countries, would like to have a ready means of saying whether the interruption had been due to submarine disturbances or to some other operation, as, for example, war. Those who lay cables would prefer to have information as to positions of suboceanic sites of seismic activity

from records made in their own country rather than those which had been made abroad. When after great convulsions cities have to be rebuilt, and there are many at the present moment, it is natural that information bearing upon reconstruction to reduce earthquake effects would be sought for at the world's central office, and those who supply information would in all probability supply engineers and material. Insurance companies who wish to apporportion rates to risks when insuring against earthquake effects might also think it best to seek their information at a central bureau. After an earthquake, when such

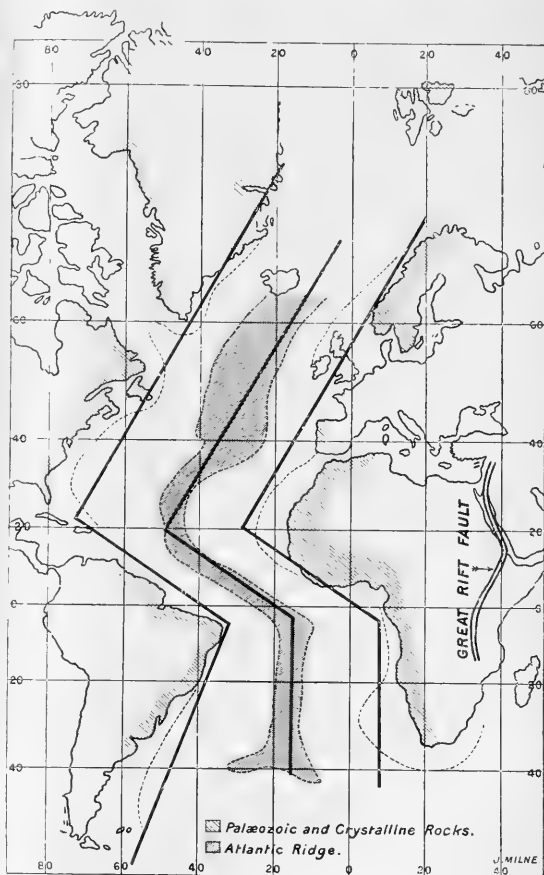

FIG. 2.—The folds and probable direction of fault lines in the Atlantic.

companies are called upon to pay the insured, many difficult questions arise which can only be answered by seismograms. Millions of pounds sterling are dependent upon these records, and it is therefore important that the same should be readily accessible. A seismogram, which travels quicker than a telegram, may affect the Stock Exchange. We no more require a central bureau to discuss applied seismology than we do to discuss the construction of torpedoes or flying machines.

A discovery which, during the last few years, has done

much to popularise seismology is the fact that a very large earthquake originating in any one part of the world may be recorded in any other portion of the same. This means that the opportunity for carrying on seismological research is not a monopoly enjoyed only by those who reside in earthquake countries. Although only a few persons in Great Britain have been privileged to feel one of its home-made tremors, every one of its inhabitants is very many times per year moved by earthquakes. Back and forth motion of the ground is performed too slowly for us to feel, while, if there is a movement like the swell upon an ocean, the undulations are too long and flat for us to see.

Waves start out from their epicentral area, which is a district that has been fissured and shattered by the formation or extension of large faults in all directions. Observation, however, shows that these waves are propagated farthest in one particular direction. For example, the chief movement following the San Francisco earthquake, which originated from fault lines running parallel to the coast of California, was much more marked in countries lying to the east or west of California than in countries lying towards the south. England and Japan obtained large records of the disturbance, while in Argentina the records were extremely small. In the case of the Jamaica earthquake, where the lines of origin ran east and west, the phenomenon was reversed. Toronto received a large quantity of motion, and England a very little. Another peculiarity of this phase of earthquake motion is that it may be propagated in one direction round the world to a greater distance than in an opposite direction. The suggestion is that the initial impulse was delivered in the direction towards which motion was propagated farthest. If for illustration we assume that the slip on a fault line has been downwards towards the east, then the motion would travel towards the east farther than it would towards the west. That which happens corresponds to what we see if we dip the blade of a spade in water and suddenly push the blade in some particular direction. The water waves thus created travel farthest in the direction of the impulse.

Another curious phenomenon connected with the large waves of certain earthquakes is that they can pass their equatorial or quadrantal region unobserved. They may be very marked for 1000 miles round their origin, and recordable, but much reduced in size, about their antipodes, but not recordable in between. For example, an earthquake originating near New Zealand may be recorded in that country, but not in India, Egypt, West Asia, or east of Europe, though in Britain it may make itself evident by the thickening of a photographic trace. The phenomenon may be compared to a water wave running down an expanding estuary. At the mouth of such an estuary it may have become so flat that it is no longer recognisable. Should it, however, run up a second estuary, we can imagine concentration taking place, so that near the top of the second estuary it would eventually become instrumentally recordable. In these antipodean survivors we see the final efforts of a dying earthquake. It is only occasionally that the precursors and the followers of these large waves have sufficient energy to reach their antipodes. They die *en route*. The former, notwithstanding their comparative feebleness, because they throw considerable light upon the internal constitution of our earth, are the most interesting feature in a seismogram. They are of two kinds, a first phase and a second phase. These are usually regarded as compressional and distortional modes of wave propagation. The large waves are probably quasi-elastic gravitational waves, something like an ocean swell, which travel round the world with a constant velocity of about 3 km. per sec., causing continental surfaces to rise and fall like huge rafts upon a heaving ocean. The precursors behave quite differently. Phase I. may commence with a velocity of 3 km. or 4 km. per sec., but as the length of the wave-path increases this quickly rises to 10 km., and thence to a maximum of 12 km. per sec. These paths are assumed to be along chords, and so long as these chords do not lie at a depth greater than twenty or thirty miles, the speeds are such as we should expect to find in materials like those composing the outer surface of our earth. These waves, therefore, indicate a thickness for the earth's

crust comparable to thicknesses which have been arrived at by other lines of argument. The rapid approximation to uniform speed suggests that below a depth of twenty or thirty miles we enter a nucleus which is very rigid and fairly homogeneous. The second phase waves, up to a distance of 120° from their origin, have a speed of about 6 km. per sec. For longer paths, Mr. R. D. Oldham points out that their velocity is apparently suddenly reduced. He seeks for an explanation of this by postulating the existence of a central core in the earth where waves are retarded and refracted, with the result that the wave-paths no longer follow chords. These waves may, therefore, emerge on the surface of the earth after having passed relatively to their starting point on the farther side of its centre. Whether we do or do not accept this central core, it is clear that the new seismology has added in a very marked manner to the knowledge we formerly possessed respecting the interior of the globe upon which we live. Our ideas respecting its homogeneity and its great rigidity have been changed by seismological investigations.

When large earth waves sweep round the world, it is found that at particular stations magnetic and electrometer needles have been disturbed. Magnetometers, when installed at Toronto, do not appear to have responded to the slow undulations of the earth's surface, while the same instruments, after being removed to Agincourt, only ten miles distant, are now affected. The inference from this and observations in other parts of the world is that the movements, rather than being caused mechanically, may be due to the disturbance of some adjacent magnetic magma. If this is the case, then at particular stations, where the movements due to teleseisms correspond with unusual disturbance of magnetic needles, inasmuch as a magnetic magma is denser than common rock, at these stations the value for g should be higher than that which would be anticipated. For certain stations this appears to be the case.

Another series of investigations which may widen our knowledge respecting conditions and operations beneath our feet are based upon the light effects which have been so frequently observed at the time of large earthquakes. Accounts of luminosity in the heavens and on hills as accompaniments to large earthquakes are common. At the time of the Valparaiso earthquake, August 17, 1906, the attention of very many people was attracted to lights which appeared upon the hills. Captain Taylor, of the R.M.S. *Orissa*, compared these to chain lightning, which extended as far as the eye could reach. An acquaintance of mine, Mr. G. E. Naylor, of Valparaiso, told me that he saw the lights repeatedly, and they took place immediately before a shock, there being only a fraction of a second of time between the two. He described them as having a bluish tinge; to others, however, they appeared yellowish. An ordinary explanation for these appearances is that they are due to the rubbing together of rock surfaces or the discharge of frictionally produced electricity. These observations suggest that with a megaseismic collapse, not only do we get mechanical disturbances which pass through and over the surface of the world, but that part of the initial energy at the origin is converted into some other form of energy, which possibly may find a response at very distant places. This latter transmission would, however, take place with a velocity comparable with that of light. If anything of this sort has a real existence, seismologists may hope to record earthquakes at the moment they take place. This consideration, and the observation that from time to time a quarry in the Isle of Wight, known as Pan Chalk Pit, appeared to me to be luminous, suggested the possibility of hypogenic activities giving evidence of their existence in the form of light. Pan Pit faces north, and in winter it is not reached by the sun. Its glowings apparently rise and fall in intensity, and are most noticeable after a dull, damp day. The experiments I made were as follows:—at the end of a chamber twenty yards from the mouth of a tunnel driven into the chalk, a hole about 2 feet square was excavated. Into this a box with a light-proof door was cemented. The back of the box, which touched the chalk, was made of zinc. In the zinc three holes of different sizes were made along a vertical line. A cylindrical drum, covered with bromide

paper and driven by clockwork, was brought up to within one-eighth of an inch from these holes. A rim on the bottom part of the drum had a clearance given to it by cutting a horizontal slit in the zinc plate beneath the holes. Neither the drum, the paper, nor the rim touched the zinc plate or the chalk. The rate of movement of the paper was 90 mm. per day. A small electric lamp moved about outside the box produced no effect upon the paper inside. A self-recording thermometer and a hygrometer showed that the temperature and the moisture in the chamber were practically constant. A similar piece of apparatus was installed at a depth of 160 feet in the King Edward Mine, Camborne, Cornwall. These experiments were commenced at Pan Chalk Pit in February, 1903, and were continued for four months. They were taken up again in the middle of August, 1906, and lasted eight months. A sheet of paper on development was frequently quite clear, but at times it was partly or entirely marked with dark bands, black lines, round black spots, or semi-circular spots along the lower edges. At Shide the dark bands have not been numerous, but they occurred on nearly all the sheets from Camborne. In certain cases we appear to have three bands, the positions of which apparently coincide with the three holes in the zinc plate. In some of these bands there are hard black lines broken along their length and made up of black spots.

The black spots vary in diameter from a fraction of a millimetre to 8 millimetres. In the centres of some of these there is a small white or brownish spot. As pointed out by Mr. W. H. Bullock, of Newport, these closely resemble spots which can be produced on bromide paper by a tiny electric spark. During a week we may have either no spots, one spot, or a hundred spots. The semi-circular spots, which I have called *singeings*, are found on the lower edge of the paper where the brass cylinder joins the aluminium rim. There may be two or three of these per week, whilst at other times they occur at intervals of about half an hour. As only ten black spots occurred at the time of large earthquakes, we can only regard these as coincidences. Neither dark bands, spots, nor *singeings* appear to be connected, beyond what I have mentioned, with any particular meteorological conditions. Neither is there any reason for supposing that these effects are due to radio-activity. If a piece of bromide paper is sealed up in a black envelope, and another piece is placed in a black envelope which has a thin glass window, and these are laid on a surface of chalk, the glass window touching the same, say, for a period of several days, it was found after development that one piece of paper showed the image of the window, whilst the other had only stains, which might be attributed to dampness. With the object of determining whether micro-organisms played any part in the phenomena observed, my friend Dr. R. C. Brown, of Parkhurst, has made cultures from scrapings from the surface of the chalk before which my cylinder was exposed. Cultures were also made from scrapings taken from the open chalk. Micro-organisms were found in both. These have been exposed to a moving photographic surface similar to that used in the pit, but they gave no evidence of luminosity. The conclusion for the present is that the luminosity occasionally seen at Pan Pit may result from a very feeble brush or glow-like electrical discharge. If this be the case, it would also account for the bands on the photographic paper, the other markings being due to minute sparks. Moreover, if this is so, and we assume that silent electrical adjustments have a real existence, it is difficult to escape the conclusion that these must have an effect on what we call "climate," and hence upon everything that lives upon the surface of the globe. We have many instances of places only separated by a few miles, as, for example, Newport and Sandown in the Isle of Wight, or Bournemouth and Swanage, where the climates of which are said to be very different. The thermometer, barometer, and hygrometer do not explain these differences; the only apparent difference between such places appears to be one of soil and the moisture in the same. Inasmuch as we find great differences in the emanations from granite, claystone, and chalk, it would seem extremely probable that we should find differences in the relative electrical conditions of different soils.

To determine whether earthquakes are increasing or

decreasing, it is not only necessary to turn over the pages of many histories, but also to consult the geologist. Jules Verne might perhaps have dipped deeper into time than a geologist or physicist, and drawn pictures of the reactionary effect which might accompany the collision of one world with another, bombardments of great meteorites, a click that announced the birth of our moon, the sudden yieldings of a primitive crust covering an ocean of molten rock, and of many other things that float through the brains of those who entertain us with the results of their imaginations. The greater number of earthquakes, and certainly all that are large, originate from the formation or extension of faults. These operations have been most marked when secular movement amongst rock masses is in progress, as, for example, during the growth of mountains. Should this be in operation near large bodies of waters, volcanoes and earthquakes are found in the same region. If, therefore, we wish to know when earthquake frequency and intensity was at a maximum, we turn to those periods in geological history when mountain ranges were built, when volcanic activity was pronounced, and when great faults were made. The first of these periods would be coincident with the creation of the Urals, the Grampians, and other ancient mountain ranges. This took place in Palæozoic times. Another period of mountain formation was in early Tertiary times, when the Himalayas and the Alps were slowly, but intermittently, brought into existence. In both these periods volcanic activity was pronounced, and beds of coal were formed. When the crust of the earth was crumbling, mountains grew spasmodically, faults gave rise to earthquakes, volcanic forces found their vents, and conditions existed which gave rise to the accumulation of materials to form coal.

In quite recent times, many large faults have been created at the time of earthquakes. In 1891 the Mino-Owori fault was created in central Japan, 10,000 people lost their lives, and 128,000 buildings were destroyed. On April 18, 1906, San Francisco and other towns were ruined by movements along a fault which can be traced for a distance of 200 miles. One estimate suggests that it may be 400 miles in length. The largest fault which has been created in extremely recent geological times seems to be the Great Rift Valley of Central Africa. We are told that it commences in the south near Lake Nyassa, passes northward through Tanganyika, the great lakes of Central Africa, branches north-eastward towards Lake Rudolph, up the Red Sea, through Akaba to the Jordan Valley, a distance of 4000 miles. In certain districts it shows itself as a strip of country let down between two parallel fractures. It has been compared to the cracks which can be seen in the moon. If we accept this as a reality, we have only to imagine this Great Rift fault to be extended as regards its length and breadth, and we have a trough in many respects similar to that which holds, not thirty lakes, but the waters of the Atlantic. If we look at the Atlantic, either as shown on a Mercator's chart or on a globe, we notice the complementary resemblances between the contours of the old world and the new. Then, if we draw a line down the submerged backbone of this ocean, we see that this is the reflection of the European and North African western coast line (Fig. 2). Next, if these old-world contours are pushed westwards towards this median line, while the contours of the two Americas are pushed eastwards, we find that one approximately fits in with the other. The fit becomes more marked if we bring together the submerged edges of continental shelves or lines representing the general direction of the opposing coast lines. Another point not to be overlooked is that the rock formations on the west side of the Atlantic are very similar to those in the same latitude on the eastern side. It is as if we had a street with the shops on one side of it exactly similar to those on the other side. In northern Spitsbergen, and again in Greenland, we find a large development of crystalline and Palæozoic rocks, and these continue southwards through Labrador, Newfoundland, Maine, and then through the Alleghanies. They again appear in Brazil as far south as Monte Video. On the eastern frontier of the Atlantic, from Scandinavia through Scotland and Ireland, Wales, western France, and western Africa as far as Cape Town, we see a replica of the two Americas. The Atlantic is a canal, the opposing banks

of which are symmetrical in form and geological material. An idea, but one which is not very probable, which this suggests is that at some very early period in the world's history two Rift Valleys, one parallel to the eastern submerged backbone of the Atlantic, and the other parallel to its western frontier, were formed. Separation subsequently took place along these faults, and these, under the influence of surface and underground activities, have continually increased. If, then, the Atlantic had an origin due to Rift Valley formation rather than to folding or contraction, then the greatest earthquake in the history of the world may have taken place when east became east and west became west, and our world was cracked from pole to pole.

Just as the frequency of earthquakes has fluctuated during geological time, similar fluctuations have taken place during historical time. In central Japan earthquake frequency had a maximum in the ninth century, and since that time, century after century, violent shakings have become less and less. In January, 1844, at Comrie, in Perthshire, twelve earthquakes were recorded. Now there may not be one per annum. At the present time, in consequence of the destruction of several large cities, the popular idea is that earthquakes are on the increase. As a matter of fact, the world as an earthquake-producing machine has a steady output. On the average, about sixty very large disturbances are recorded, and the greater number of these, fortunately for humanity, have their origins beneath ocean beds or in sparsely inhabited regions. In addition to these megaseismic efforts, it is estimated that about 30,000 small earthquakes take place per year, England's annual contribution to this number being about half a dozen. If we had records like these extending backwards through several ages, we might readily estimate the time when seismic activity would cease. When this ceases, rock folding will also cease, and the degrading processes resulting in surface denudation will be unopposed. Bit by bit land areas will be reduced to sea-level, and the habitable surfaces, as we now see them, will be no more.

An interesting observation bearing upon megaseismic frequency is found in the analyses of registers relating to the North Pacific. On the west side of that ocean seismic frequency is greatest in the summer, while on the east side it is greatest in the winter. An explanation for this is sought for in the seasonal alteration in the flow of ocean currents, the oscillations of sea-level, and changes in the direction of barometric gradients, which phenomena are interrelated. In summer, off the coast of Japan, the Black Stream runs perhaps 500 miles farther north than it does in winter, while Dr. Omori points out that, although barometric pressure may on the Japan side of the Pacific be low in summer, this decrease in load is more than compensated for by the increased height of ocean-level; the inference is that the pressure on the ocean bed is greater in summer than in winter, and this is the time of the greatest seismic frequency.

Another factor bearing upon earthquake frequency may perhaps be found in the change in position of the earth's pole. A chart showing the path of the earth's north pole indicates that its movements are by no means always uniform. Although at times these may be nearly circular, it also shows sharp changes in the direction of its motion. It has even been retrograde. If on a chart showing these pole displacements we mark the time positions of world-shaking earthquakes, it is seen that these are grouped round the sharper bends of the pole-path. World-shaking earthquakes have, in fact, been most numerous when the pole-path has deviated farthest from its mean position. The observations embrace a period of thirteen years, during which 750 large earthquakes were recorded. Although these earthquakes represent large mass displacements, it is not supposed that they would be sufficient to produce the observed pole movement. The pole movement, however, may have given relief to seismic strain, or both effects may arise from some common cause.

Mass displacements accompanying a megaseismic effort must, however, tend to produce some pole displacement, and thus set up strains. From time to time these should find relief in the weaker portions of the earth's crust. Large earthquakes should therefore occur in pairs, triplets, or in groups, after which we should expect a period of

quiescence. This idea is due to the Rev. H. V. Gill, S.J. I find that the British Association registers lend considerable support to the hypothesis. The author of the idea, however, goes a step farther, and points out that if all matter within our globe or that which constitutes its crust was equally free to move, the secondary displacement should, with regard to the earth's axis of rotation, be symmetrically located in regard to the position of the primary disturbance. Out of 126 large earthquakes recorded between 1809 and 1905, I find that twenty of these appear as ten pairs, the members of each pair being in symmetrically located districts. This may or may not have been a matter of chance. The observation that a marked relief of seismic strain in one part of the world has frequently been followed by a smaller relief in some distant region also suggests the idea that earthquake begets earthquake. In my own mind the relationship of earthquake to earthquake has been fairly well demonstrated, but to place the matter beyond the borderland of doubt large earthquakes must be compared in regard to space and time with their kind, with small earthquakes, and with volcanic eruptions. All the volcanic eruptions of the West Indies have closely followed on the heels of great earthquakes which have originated, not in the West Indies, but on the neighbouring coasts of Central and South America. One general inference is that the faultings and freckles on the face of our world should have a distribution as symmetrically disposed as wrinkles are on the face of an elderly person.

Already when speaking about the length of faults which have been created at the time of large earthquakes, we have indicated at least one dimension of the earth block which has been disturbed. For instance, the earth block which was disturbed at the time of the San Francisco earthquake may have had a length of 400 miles; its breadth might be determined by the width of the country which had been broken up by branching and parallel faults. Harboe suggests that in a meizoseismic area hidden faults may be assumed to exist along lines drawn half-way between pairs of groups of places which have been struck at about the same time. R. D. Oldham attributes the Assam earthquake of 1897 to the sudden shifting of 10,000 square miles of territory over a thrust plain. The molar displacement determined by the method suggested by Harboe would be that 50,000 square miles had been disturbed. The fact that so many earthquakes shake the whole world, or will agitate an ocean like the Pacific for many hours, indicates that the initial impulse must have been delivered over a large area, or that sudden alterations have taken place in the contour of ocean beds. With regard to the magnitude of the latter changes, we have learnt much from cable engineers, who have given us many instances where cables lying in parallel lines, ten or fifteen miles apart, have been simultaneously interrupted, and ocean depths over considerable areas have been increased. The depth to which these large faults extend is a matter of inference. We may well imagine them as passing through the whole thickness of the earth's crust, and the displaced block falling to give up its energy to a nucleus which we know transmits undulatory movements all over our globe with uniform velocity. If we take this crust to be thirty miles in thickness, then with Harboe's area for the superficial disturbance, the block which was disturbed at the time of the Assam earthquake would be represented by $1\frac{1}{2}$ million cubic miles.

Following the initial impulse of a large earthquake, it frequently happens a few minutes later that a second severe movement is felt. In Japan this is popularly spoken of as the Yuri Kaishi, or the return shaking. This may be a second yielding within the disturbed district, but from its resemblance to the main shock it suggests an echo-like reflection. If we drop a bullet into a large tub of water, waves travel outwards to the sides of the tub, where they are reflected, and converge at the centre from which they set out. With the earthquake waves, the reflecting surface may be represented by the roots of mountain ranges. If these are at varying distances from the origin, the reflected waves would give rise to complications at the focus. The transmitting medium for these waves I take to be the more or less homogeneous material which lies beneath the heterogeneous crust of our world. This

transmits large waves with a constant velocity. In the case of the Californian earthquake, which originated on fault lines on the western side of that country, I should imagine the reflecting surface to be the Sierras, 200 miles distant. The wave group would travel to these mountains and back in about four minutes, and this is approximately the time interval between the two first large wave groups in seismograms I have of that disturbance. After the first echo or echoes, an earthquake usually dies out as a series of surgings which frequently have a striking similarity to each other. One explanation of these rhythmic recurring groups is that they simply represent times when the movement of the ground has synchronised with the natural period of the recording instrument. Although the terminal vibrations seen on a seismogram may be attributed to this cause, it does not exclude the idea that rhythmical beats at an origin may result in rhythmical responses at a distance.

Side-issues of seismology are quite as instructive as the information we derive from the records of earthquakes. We have already referred to light effects which accompany large earthquakes. This, as we have seen, led up to investigations connected with micro-organisms. A long series of experiments, which commenced in Japan and were continued in the Isle of Wight, involved a series of investigations bearing upon the transpiration of plants. The fundamental object of these experiments was to determine whether valleys always retained the same form. Did they open and shut? To answer the question I set up on the two sides of a valley horizontal pendulums identical with those which are used to record teleseismic motion. These instruments, which are by photographic means self-recording, are exceedingly sensitive to small changes in level. What I found was that on fine days the booms of these instruments moved in opposite directions, each away from the bed of the valley. At night the motions were reversed, and the booms moved towards each other, that is, towards the bottom of the valley. Several instruments were employed, and the records were confirmed by the movements of the bubbles of sensitive levels. During the day the records indicated that the sides of the valley opened, and at night they closed. The two valleys I worked upon behaved like ordinary flowers, they opened when the sun was shining and closed at night. The best explanation I can offer is that the phenomenon is largely dependent upon the transpiration of plants. This is marked during the day, but not at night. On a bright day a sunflower or a cabbage may discharge 2 lb. of aqueous vapour. A square yard of grass will give off 10 lb. or 12 lb. The result of this is that during the day underground drainage has not received its full supply of water to load the bottom of the valley. At night time, when plants' transpiration is reduced, subsurface drainage is increased, and the load at the bottom of the valley is also increased. Therefore, at night the bottom of a valley, in consequence of its increased water load, is depressed, and this is accompanied by a closing of its sides. During the day the load runs off, and the valley opens. This may also explain why soak wells in valleys and streams carry less water during the day than they do at night, and at the same time it suggests that the side of a valley is a bad place for an observatory. Every day as the world turns before the sun, lamp-posts and tall structures salute the same, whilst many valleys open. At night time these movements are reversed.

One phenomenon which accompanies all large earthquakes, which, however, has never yet received the attention it deserves, is the influence which great disasters have exercised upon the emotions. Immediately after the Kingston earthquake we read of the dazed and almost insane condition of the people. Many were affected with an outburst of religious ecstasy, thinking the last day had come. The negro population camped on the racecourse, and spent their time in singing hymns. Somewhat similar scenes took place in Chili; men and women ran hither and thither, mad with terror and devoid of reason. Amid shrieks and sobs, and the wailing of a multitude, an "Ora pro Nobis" or a "Pater Noster" might now and then be heard. In early civilisations underground thunderings have so far excited the imagination that subterranean monsters or personages have been conjured into existence,

and these in many instances have played a part in primitive religions. At the time of an earthquake in Japan, the children are told that the shaking is due to the movement of a fish which is buried beneath their country, and in Japan we find references to this fish in the pictorial art, glyptic art, literature, and everyday conversation, all of which would be unintelligible if we did not know the story of the earthquake fish. In other countries the subterranean creature will be a pig, a tortoise, an elephant, or some other animal. The most interesting myths, however, relate to underground personages. The forty-five Grecian Titans, who were of gigantic stature and of proportionate strength, were confined in the bowels of the earth. According to the poets, the flames of Etna proceeded from the breath of Enceladus, and when he turned his weary side the whole island of Sicily was shaken to its foundations. Neptune was not only a god of the oceans, rivers, and fountains, but with a blow of his trident he could create earthquakes at pleasure. The worship of Neptune was established in almost every part of the Grecian world. The Livians, in particular, venerated him, and looked upon him as the first and greatest of the gods. The Palici were born in the bowels of the earth, and were worshipped with great ceremonies by the Sicilians. In a superstitious age the altars of the Palici were stained with the blood of human sacrifices. In Roman mythology, two very familiar deities are Pluto and Vulcan. These and a host of other deities, the outcome of imagination, excited by displays of seismic and volcanic activity, we meet with every day in picture galleries, in museums, in literature, and in our daily papers. The fact that we are enjoined not to make any graven image of that which is in the earth beneath suggests that in the time of Moses a certain form of worship called for some correction. Over and above adding a clause to the decalogue, large earthquakes have in very many ways affected religions. After the earthquake which shook England on April 6, 1580, the then Archbishop of Canterbury drew up a form of prayer which was approved by the Privy Council, and ordered by them to be read in all dioceses in the kingdom. In the world there are many instances of religious services being held on the anniversary of an earthquake, it being regarded as an exhibition of God's vengeance upon a wicked people. The belief that earthquakes are signs or warnings owes its origin in part to prophecies in the Bible, where, for example, we read that "there shall be famines and pestilences and earthquakes" as portending future calamities. Earthquakes have led to the abolition of oppressive taxation, the abolition of masquerades, the closing of theatres, and even to the alteration in fashions. A New England paper, of 1727, tells us that "a considerable town in this province has been so far awakened by the awful providence in the earthquake that the women have generally laid aside their hooped petticoats."

UNIVERSITY AND EDUCATIONAL INTELLIGENCE.

THE success of the Children's Museum in Bedford Park, Brooklyn, as a factor in education forms the subject of an article by Miss A. B. Gallup in the April number of the *Popular Science Monthly*. At its commencement in 1899 the museum comprised only two rooms, containing little more than a few insects, shells, and stuffed birds. The eagerness with which these were visited by children soon led, however, to extension, and twelve exhibition rooms, furnished with specimens, models, and pictures illustrative of nearly every subject interesting to childhood, are now open to the public. These collections illustrate the chief branches of natural history, geography, art, and the history of the United States. Young people are encouraged to think and act for themselves, one result being the installation of a wireless telegraph apparatus by a party of boy visitors, some of the members of which subsequently obtained appointments as wireless telegraphists. The institution seems worthy of imitation in this country.

DR. W. E. HOYLE, director of the Manchester Museum, speaking on children's museums at a museum conference

held at Preston on April 11, remarked, in reference to the American institutions of this kind, that in the one at Brooklyn the following aims have been kept in view:—(1) to employ objects attractive and interesting to children, and at the same time helpful to teachers in every branch of nature-study; (2) to secure an arrangement at once pleasing to the eye, expressive of fundamental truth; (3) to avoid confusion from the use of too many specimens, and the consequent close crowding in cases; (4) to label with brief descriptions, expressed in simple language and printed in clear, legible type. The keeping of live animals is an important branch of the work, and a source of endless interest to the young visitors. A striking exhibit is a series of historic models illustrating the six chief types of people who formed permanent settlements in North America.

A SCHEME is under consideration for the establishment of a university in Hong Kong. Mr. Mody has placed at the disposal of Sir Frederick Lugard, the Governor of Hong Kong, a sum of 15,000*l.* for the purpose. At a recent meeting, according to Reuter's agent, Sir Frederick Lugard said he is willing to recommend the Government to provide a site, but cannot go further than that in view of the liabilities of the Government. He believes that if Hong Kong could establish a university with facilities equal or superior to those at Tokio, it would attract a large number of the wealthy Chinese students who now go to Japan, America, and Europe, and would increase the prestige and influence of Great Britain throughout the Chinese Empire. To provide an adequate endowment for even the modest beginning proposed, a sum of not much less than 100,000*l.* will be required.

THE treasurer of University College, Bristol, has received a donation of 500*l.* from the University College Colston Society for general purposes, and a grant of 500*l.* from the Board of Agriculture to enable the department of economic biology to carry on its investigations on the effect of electricity on plants. The County Council of Somerset has approved a scheme of research in connection with Cheddar cheese-making, and has authorised an expenditure of 200*l.* for the first year on this work. The Gloucestershire County Council has passed the following resolution in support of the movement for the establishment of a university in Bristol:—"That this council approves of the scheme for promoting the Bristol University, and will consider what, if any, financial assistance they can accord to it when the scheme is more fully developed."

IN an address at the graduation ceremony of the University of Edinburgh on April 10, Prof. Chrystal referred to reforms in secondary and university education in Scotland. In 1856 Prof. Chrystal placed before the Scotch Education Department a scheme for a general leaving certificate examination for schools. The department approved the suggestion, and Sir Henry Craik carried out the scheme in detail with very satisfactory results. Prof. Chrystal now proposes to make the Scotch Leaving Certificate examination the normal course of entrance to each university, and to abolish the university preliminary examination. Already the leaving certificate examination is accepted by Scotch universities in lieu of the preliminary examination for the subjects it covers, and it is desirable to make the examination a complete passport to the universities. Part of Prof. Chrystal's original proposal to the Scotch Education Department regarding the leaving certificate was the creation of a National Board of Surveillance, on which the department, the schools, the universities, and certain other public bodies were to be represented. His object was to avoid the necessity for the institution of a university preliminary examination. A generally accepted standard for entrance to the University is an inevitable element in university reform; but the administration of a general leaving examination for schools is not the proper business of the universities. No doubt one of the functions of a leaving certificate should be to qualify for an academic course, but it has many other functions besides, and all that the universities should claim is a share in the surveillance of the leaving certificate in so far as it concerns them. Prof. Chrystal went on to say that the advance of secondary education, in par-

ticular the opening of junior student centres all over Scotland, is rapidly preparing the way, if it has not already prepared it, for carrying out the ideal of the Universities' Commissioners. "I turn, therefore, with renewed hope and renewed insistence to the men of wisdom and of influence, who hold in their hands our educational destiny, and ask them to consider once more my old proposal for a National Board, which shall regulate the schools' leaving certificate, so that it shall become the normal portal of admission to the universities, and render the present preliminary examination and the present Joint Board and all its works unnecessary. This reform must, of course, be taken up as a national affair. It is no matter of the autonomy of the universities. It concerns the welfare and good government of all the secondary schools of the country; also, I may say, the relation of our standards of secondary education to similar standards all over the British Empire."

SOCIETIES AND ACADEMIES.

LONDON.

Linnean Society, April 2.—Lieut.-Colonel Prain, F.R.S., vice-president, in the chair.—The anatomy of some sapotaceous seedlings: Winifred Smith. The seedlings of the Sapotaceae are remarkable on account of (1) their exceptional mode of transition from root to stem; (2) the lack of continuity in the different parts of the vascular system; (3) their tendency to a geophilous habit. To Dangeard's axiom:—"Le plan vertical médian des cotylédons correspond toujours à un vaisseau vasculaire de la racine," the sole exceptions vouched for are trees, and occur in the Sapotaceae and in two genera of the Fagaceae.—Notes on some sponges recently collected in Scotland: Dr. N. Annandale.

Society of Chemical Industry (London Section), April 6.—Dr. Lewkowitsch in the chair.—Considerations affecting the "strength" of wheat flours: Julian L. Baker and H. F. E. Hulton. It is improbable that any one chemical or physical determination can be used for determining the "strength" of flours, as the generally accepted definition includes two distinct qualities, viz. size and shape of loaf. It is recommended that bakers should apportion marks independently for size and shape. A proteolytic enzyme capable of degrading the gluten, and so influencing the character of the loaf, appears to be absent, but there is a small quantity of an erepsin. Yeast enzymes can effect partial proteolysis of gluten. Aqueous flour extracts depart from Kjeldahl's law of proportionality. Maltose is the sole sugar formed during doughing. Flours on keeping display changes in enzymic activity. Doughs have a greater diastatic activity than either the aqueous extract of the flour or the flour itself, and this activity varies inversely with the amount of water present. Flours contain a starch-liquefying enzyme, and this enzyme is closely connected with gas production. The formation of gluten from gliadin and glutenin is independent of enzymic activity, and is probably only a hydration phenomenon. Gliadin separated from flour was re-combined with the residual gluten and starch, and the gluten, in a weakened condition, was recovered by washing out. The diastatic activity of gluten is confirmed, and shown to reside in the glutenin moiety.—The occurrence of cyanogenetic glucosides in feeding stuffs: T. A. Henry and S. J. M. Auld. In association with Prof. Dunstan, the authors have investigated a number of plants which yield prussic acid when in contact with water, and show that the prussic acid is formed by the interaction of a glucoside and an enzyme which decomposes it, liberating prussic acid. Several of these plants are employed as feeding stuffs, notably Java beans, and it is to this liberation of prussic acid that the numerous cases of poisoning of cattle by these beans are due. Linseed cake also contains a cyanogenetic glucoside, but the high temperature to which the cake is heated in the course of manufacture destroys the enzyme originally present in the seed. The seed of the Para rubber tree, sometimes used for feeding purposes in the tropics, also yields small quantities of prussic acid.—Note on murexide as a quoniam dye-stuff and printing colour: Watson Smith. The author exhibited a specimen

of commercial murexide manufactured about the year 1861, and also a specimen of calico printed with it, which still exhibited the characteristic bright rose tint.

Zoological Society, April 7.—Dr. Henry Woodward, F.R.S., vice-president, in the chair.—A monograph of the chiropteran genera *Uroderma*, *Enchisthenes*, and *Artibeus*: Dr. Knud Anderson. The work was based on an examination of the material in the British and United States National Museums, and contained a discussion of the homologies of the teeth and molar cusps in steno-dermatous bats, a full description of the genera mentioned in the title, their species and subspecies, with a discussion of their probable inter-relations, and, finally, remarks on the bearing of the present geographical distribution of the species and subspecies on a former connection of the West Indian Islands with continental America.—Certain points in the structure of the cervical vertebrae of the okapi and giraffe: Sir E. Ray Lankester. The paper dealt chiefly with the posterior cervical and anterior dorsal vertebrae, the author concluding that where the okapi differed in these respects from the giraffe, it resembled other, and particularly bovine, Artiodactyles. It also included a discussion of the zygapophysial articulations of the cervical and dorsal vertebrae in the giraffe, okapi, and some other mammals.—Some Australian spiders: H. R. Hogg. The author gave further notes on the type species of the genus *Missulena*, hitherto known only by two specimens, a synopsis of the New Zealand genus *Hexathele*, with description of two new species, and a description of two new species of *Dolomedes* (Latreille) from Pitt Island of the Chatham Group, showing affinities with the only two species recorded from New Zealand.

Association of Economic Biologists, April 15.—Mr. A. E. Shipley, F.R.S., president, in the chair.—The pecking of fowls and their vision: E. Stearns.—The inter-relationship between entozoa and their hosts: A. E. Shipley. The author emphasised the important rôle internal parasites play in disease, the full weight of which had scarcely been realised as yet by the medical profession.—The predisposition of plants to parasitic diseases: H. T. Güssow.—The need of an organised inquiry into the feeding habits of British birds: C. Gordon Hewitt.—The possibility and danger of the introduction of the San José scale into Great Britain: Walter E. Collinge. The author had seen this scale alive on pears in this country, and twigs had been sent to him from Canada on which the insects had reproduced by eggs, and hatched out in his laboratory. In view of its spread northwards in Canada, he was of opinion that some stricter and more careful examination of imported nursery stock should without delay be organised and carried out in this country.—An important factor in the natural control of the large larch saw-fly, *Nematus erichsonii*: C. Gordon Hewitt. The factor referred to was the field vole (*Arvicola agrestis*), which extracts and eats the larvae from the cocoons.

Royal Meteorological Society, April 15.—Dr. H. R. Mill, president, in the chair.—Report on the phenological observations for 1907: E. Mawley. Wild plants came into blossom behind their usual dates throughout the whole of the flowering season. Such early immigrants as the swallow, cuckoo, and nightingale were also behind their average dates in reaching these islands. The only deficient farm crop, taking the country as a whole, was that of potatoes, most of the other crops being much over average. On the other hand, the yield of apples and pears, and particularly that of the former, was below average. There was also a deficient crop of strawberries, whereas plums, raspberries, currants, and gooseberries were over average.—Anticyclonic belt of the southern hemisphere: Colonel H. E. Rawson. From an examination of the daily synoptic charts of the northern hemisphere, the author was led to the conclusion that some of the permanent anticyclonic systems had a progressive seasonal movement which did not take place along the same latitude each year, but was in some years north and in others south of a mean latitude. This was noticeable in the years 1881–1891, and was capable of easy explanation if the belt itself in which they moved shifted its latitude from year to year in addition to migrating north and south with the sun. On analysing the isobaric charts of the southern

hemisphere, the author found the seasonal migration of the anticyclonic belt to be accompanied by a real displacement of the action-centres within it to the northward and to the southward. It appears that there is a period of about 9.5 years between the greatest north and greatest south position of the anticyclonic belt over South Africa, the double oscillation thus taking nineteen years.

MANCHESTER.

Literary and Philosophical Society, February 11.—Prof. H. B. Dixon, F.R.S., president, in the chair.—A method of counting the number of α particles from radioactive matter: Prof. E. Rutherford and Dr. H. Geiger. The total number of α particles expelled per second from one gram of radium has been estimated (Rutherford, *Phil. Mag.*, August, 1905) by measuring experimentally the total positive charge carried by the α rays from a thin film of radium, on the assumption that each α particle has the same charge as an ion produced in gases. If the α particle is an atom of helium, it is necessary to assume that each α particle carries twice the ordinary ionic charge. The need of a method of directly counting the number of α particles shot out from radioactive matter has long been felt in order to determine with the minimum of assumption the charge carried by the α particle, and also the magnitude of other radio-active quantities. It can be calculated that an α particle expelled from radium produces about 80,000 ions in a gas before its ionising power is lost. With very sensitive apparatus, it should be just possible to detect the ionisation produced by a single α particle by electrical methods. The effect, however, would be small and difficult to measure with accuracy. In order to overcome this difficulty, the authors have employed a method which automatically increases the ionisation produced by an α particle several thousand times, and so makes the electrical effect easily observable with an ordinary electrometer. By counting at intervals the number of α particles expelled per minute, the authors have been able to obtain the curves of decay of activity of a plate coated with radium C or actinium B. The α particles from a constant source are shot out at irregular intervals. The time interval between the entrance of successive α particles has been observed over a long interval, and the results show that the distribution curve with time is similar in general shape to the probability curve of distribution of the velocity of molecules in a gas.

February 25.—Prof. H. B. Dixon, F.R.S., president, in the chair.—Notes on the greater horseshoe bat (*Rhinolophus ferrumequinum*) in captivity: T. A. Coward. The author, after giving a résumé of his previous notes on the habits of the greater horseshoe bat, showed that the conclusions he arrived at were confirmed by the behaviour of examples in captivity. The winter sleep of this species is not profound; the bats leave their retreats and feed in mild weather. Bats in captivity usually awake every evening, but during the cold weather in January slept occasionally for one, two, or three nights. When awake they captured insects on the wing, and also, though unable to walk, dropped on the floor, seized beetles, and rose with them in their mouths without difficulty, proving how the bats are able to obtain flightless insects.—Cavity parenchyma and tyloses in ferns: Mary McInicoll.

March 10.—Dr. W. E. Hoyle, vice-president, in the chair.—Report of the recent Foraminifera from the coast of the island of Delos (Grecian Archipelago), part v.: H. Sidebottom. The author restricted himself to a consideration of two forms (*Cymbalopora bulloides* and *Spirillina erecta*) as being of special interest, and described them in some detail.—The action of selenium and tellurium on arsine and stibine: F. Jones. In a previous paper it was shown that sulphur decomposes stibine in presence of light, and at a temperature of 100° C., but not in the dark. The action results in the formation of hydrogen sulphide and antimony trisulphide. It was also shown that the liberated hydrogen sulphide decomposes stibine with formation of antimony trisulphide and free hydrogen. A similar action was found to take place between sulphur and the two gases analogous to stibine, namely, arsine and phosphine. It appeared probable that selenium and tellurium would act on these gases in a similar manner to sulphur, and this has been found to be the case.

PARIS.

Academy of Sciences, April 13.—M. H. Becquerel in the chair.—The hovering of birds: Marcel **Deprez**. The author gives a simple mechanical explanation of the motionless hovering of birds, and has constructed an apparatus capable of imitating this flight.—The determination of longitude at sea by wireless telegraphy: E. **Guyou**. The views of the Bureau des Longitudes on this subject are stated, especial emphasis being laid on the necessity for international control.—The action of heat on the hydrates of lithia: M. **de Forcrand**. A description of the methods employed in obtaining LiOH, LiOH.H₂O, and Li₂O in a state of purity, together with some thermochemical data relating to these substances.—The adiabatic expansion of saturated fluids: E. **Mathias**.—An extremely sensitive electric hygroscope: J. **Pionchon**. A glass tube is silvered over the whole of its internal surface, and external^{ly} from one end to within about a centimetre of the other. A tube is placed in circuit with a mirror galvanometer and a battery of 100 volts. The resistance of the unsilvered portion of the tube varies with the amount of moisture present in the air, and forms a very sensitive hygroscope.—The magnetic changes in the spectrum of silicon fluoride observed parallel to the field: A. **Dufour**. It has been possible to separate the bands into three groups, in two of which the Zeeman effect is abnormal, or in a sense agrees with the existence of positive electrons.—The evaporation of water and solutions of sulphuric acid: P. **Vaillant**. A study of the effect of modifying some of the conditions in the gravimetric method described in a previous paper.—A new method of estimating phosphorus in organic materials: Isidore **Bay**. The substance is burnt in a bayonet tube with sodium carbonate and magnesia. Comparative results with this and the Carius method are given for trimethylphosphine and triethylphosphine.—The sulphur compounds of thorium: A. **Duboin**. By the action of sulphuretted hydrogen upon thorium chloride in presence of sodium chloride at a red heat, two new compounds were isolated. On analysis, these proved to be ThS₂ and ThOS.—Semicatalysis: the oxidation of hydrocarbons in air in presence of phosphorus: Albert **Coison**. Solutions of phosphorus in turpentine become oxidised in presence of air, and both the hydrocarbon and the phosphorus are oxidised simultaneously. The product H₂PO₄(C₁₀H₈O₂)₂ was isolated.—A simple reaction producing a disinfectant gas: G. **Carteret**. A mixture of bleaching powder and paraformaldehyde gives a vigorous evolution of gaseous formaldehyde when mixed with water.—The alloy of platinum with thallium: L. **Hackspill**. A description of the preparation and properties of the alloy TlPt.—Austenite: Ed. **Maurer**. Starting with a metal containing 2.2 per cent. of manganese, 1.04 per cent. of carbon, and 0.94 per cent. of silicon, heating for fifteen minutes at 1050° C., and tempering in ice-cold water, the author has been able to obtain pure austenite for the first time. Reproductions of photomicrographs are given showing pure austenite, the same after deformation and after tempering at 400° C. This steel is not magnetic, and is of relatively small hardness. It can be converted into martensite by mechanical treatment at the ordinary temperature, by re-heating to 400° C., or by immersion in liquid air.—Remarks on the communication of M. Maurer relating to austenite: H. **Le Chatelier**. The previous attempts to prepare austenite are detailed, and the theoretical and practical importance of M. Maurer's discovery pointed out.—The electrical transport of inorganic colloids: André **Mayer** and Edouard **Salles**.—Helicoidal structures: Paul **Gaubert**. Observations on the development of the pistil in the Malvaceae: Jean **Friedel**.—The etiological peculiarities of the development of the mother cells of the pollen of *Agave attenuata*: Er. de Lary **de Latour**.—The morphological and anatomical connections of the human cardia: R. **Robinson**.—The thoracic nephridia of the Hermellids: Armand **Dehorne**.—The structure of the epidermis of *Trachisa Forbesii*: Louis **du Reau**.—Culture of the parasite of the *Biskra* bou. (*bouton d'Orient*): Charles **Nicolle**.

DIARY OF SOCIETIES.

- THURSDAY, APRIL 23.
 INSTITUTION OF ELECTRICAL ENGINEERS, at 8.—*Conclusion of Discussion*: Electric Supply Prospects and Charges as affected by Metallic Filament Lamps and Electric Heating: H. W. Hancock and A. H. Dykes.
 MONDAY, APRIL 27.
 INSTITUTION OF CIVIL ENGINEERS, at 8.—*James Forrest Lecture*: On some Unsolved Problems in Metal Mining: Prof. H. Louis.
 TUESDAY, APRIL 28.
 ROYAL INSTITUTION, at 5.—"The Development of the Modern Turbine and its Application": Gerald Stoney.
 ZOOLOGICAL SOCIETY, at 8.—On the Amphipod Genus *Trichostoma*: Mrs. E. W. Sexton.—On the Breeding-habits of a Cichlid Fish (*Tilapia nilotica*): C. L. Boulenger.—A Revision of the Sharks of the Family Orectolobidae: C. Tate Regan.—A Revision of the Oriental Pelobatid Batrachians (*Gerrhonotus* Megalophy): G. A. Boulenger, F.R.S.
 ROYAL SOCIETY OF ARTS, at 8.—Lace as a Modern Industry: Miss Isenmenger.
 WEDNESDAY, APRIL 29.
 ROYAL SOCIETY OF ARTS, at 8.—Modern Roumania: Alfred Stead.
 SOCIETY OF DYERS AND COLOURISTS (London Section), at 8.—The Dyeing and Colouring of Paper Pulp: R. W. Sindall.—Further Notes on the Germicidal Value of Petroleum Benzine: F. J. Farrell and F. Howles.
 BRITISH ASTRONOMICAL ASSOCIATION, at 5.—Time: Capt. F. L. Grant.
 THURSDAY, APRIL 30.
 ROYAL SOCIETY, at 4.30.—*Probable Paper*: On Scandium: Sir William Crookes, F.R.S.—Note on the Representation of the Earth's Surface by Means of Spherical Harmonics of the First Three Degrees: Prof. A. E. H. Love, F.R.S.—On the Hysteresis Loss and other Properties of Iron Alloys under very small Magnetic Forces: Prof. E. Wilson, W. H. Wilson, and G. F. O'Dell.—The Relation between the Crystalline Form and the Chemical Constitution of the Picryl Derivatives: G. Jerusalem and Prof. W. J. Pope, F.R.S.—The Condensation of Certain Organic Vapours: T. H. Laby.—A Photographic Determination of the Elements of the Orbits of Jupiter's Satellites: Bryan Cookson.
 ROYAL INSTITUTION, at 5.—Mendelian Heredity: William Bateson, F.R.S.
 ROYAL SOCIETY OF ARTS, at 4.30.—Reminiscences of Indian Life: Lord Lamington, G.C.M.G., G.C.I.E.
 MATHEMATICAL SOCIETY, at 5.30.—On a General Convergence Theorem, and the Theory of the Representation of a Function by Series of Normal Functions: Dr. E. W. Hobson.—On the Multiplication of Series: G. H. Hardy.—On η -Integration and Differential Equations: F. H. Jackson.
 FRIDAY, MAY 1.
 ROYAL INSTITUTION, at 5.—The Scientific Work of Lord Kelvin: Prof. Joseph Larmor, Sec.R.S.
 SATURDAY, MAY 2.
 ROYAL INSTITUTION, at 3.—Chile and the Chilians: G. F. Seott Elliot.

CONTENTS.

	PAGE
A New Calculus	577
Prehistoric Europe. By Dr. William Wright	578
Chemical Research	579
Our Book Shelf:—	
Stansie: "Iron and Steel"	579
Rey: "L'Énergétique et le Mécanisme au Point de Vue des Conditions de la Connaissance."—T. P. N.	580
"Abel's Laboratory Handbook of Bacteriology."—Prof. R. T. Hewlett	580
Correns: "Die Bestimmung und Vererbung des Geschlechtes"	580
Lorentz: "Lehrbuch der Physik"	580
Letters to the Editor:—	
The Condensation of Helium.—Prof. H. Kamerlingh Onnes	581
Satellites of Yellow and Green Lines of Mercury.—Prof. H. Nagaoka	581
Mendelian Characters among Shorthorns.—Prof. John G. McKendrick, F.R.S.	582
Ionisation of Air by Ultra-violet Light.—Frederic Palmer, Jun.	582
The International Mathematical Congress at Rome, by Prof. G. H. Bryan, F.R.S.	582
Jubilee of the Calcutta University	584
Recent Work on Plague. By L. N.	585
Notes	587
Our Astronomical Column:—	
Structure of the Corona	590
Spectroscopic Binaries now under Observation	590
The Relation between the Colours and Periods of Variable Stars	590
A Field Method of determining Longitudes	590
Observations of Eros	590
Variable Radial Velocity of η Virginis	590
Agricultural Experiments and Reports	590
Recent Earthquakes. (<i>Illustrated</i>) By Prof. J. Milne, F.R.S.	592
University and Educational Intelligence	597
Societies and Academies	598
Diary of Societies	600

THURSDAY, APRIL 30, 1908.

ANCIENT BRITAIN.

Ancient Britain and the Invasions of Julius Caesar.
By Dr. T. Rice Holmes. Pp. xi+764. (Oxford:
Clarendon Press, 1907.) Price 21s. net.

THIS substantial volume divides itself, roughly speaking, into two halves, of which the first is the text of the author's story of ancient Britain extended so as to include Julius Caesar's invasions and their more immediate results. The other is devoted to discussions and notes on special subjects, varying greatly in length and importance.

The summing-up at the end of the story is a cheerful reading. In some respects the author thinks we have sunk below the level of "those primitive ancestors" who form the subject of his work. He asks in what we have advanced, and answers that we have made giant strides; all that appertains to material civilisation. He proceeds in the following terms:—

"But such improvements hardly enable men to bear up under burdens which are ever increasing. The tourist in a Pullman car is not happier than those who travelled in stage-coach or waggon, and speed deprives him of as much as it bestows; machinery has but substituted fresh evils for those which it destroyed. New superstitions, less gross but not less false, have been engrafed upon the old: but 'pure religion and undefiled,'—how far has it strengthened its hold on the hearts of men?"

The reader will form some idea of the wide scope of his study of the primitive ancestors from the following headings of the chapters on ancient Britain: the Palæolithic age, the Neolithic age, the Bronze age and the voyage of Pytheas, the Early Iron age, Cæsar's first invasion of Britain, Cæsar's second invasion, the results of Cæsar's invasions.

It is to be hoped that Dr. Holmes may prove mistaken when he asserts in his introduction that we already know all, or nearly all, that sepulchres and skulls and coins can teach us of ancient Britain and its inhabitants. He goes on to express views which, if hardly more encouraging, are more likely to be in accord with those of his readers:—

"There is room also for many labourers in excavating stone circles, camps, and earthworks, and determining their age, in exploring habitations, wherever they can be found, and learning what they can teach about those who constructed them. What has been already done in this department has produced the most fruitful results. . . . But such work, which in other civilised countries is an object of national concern, languishes here for want of funds. No British Government can expect support from the intelligence and the public spirit of its constituents in spending money upon archaeological research, or has the courage to give them a lead; and where are the wealthy Englishmen who will follow the example of their American cousins in endowing such work?"

At the risk of seeming to digress, we should like to point out that this state of things shows signs of coming to an end, and we may mention as one of

our reasons for believing so the appointment not long since of a Royal Commission to report on the antiquities of Scotland. It is devoutly to be hoped that the Government will do more and extend the sphere of its activity so as to include other parts of the kingdom.

We shall now endeavour to give the reader an idea of ancient Britain and its populations as Dr. Holmes conceives of them. He regards the Bronze age as beginning in this country about 1800 years before the Christian era, but many centuries previously the island began to be invaded from various parts of northern Gaul by a Neolithic people, whom he describes as follows (pp. 64-5):—

"The skeletons that have been exhumed from the Neolithic tombs of England, Scotland, and Ireland . . . belong, for the most part, to the same general type. All, or almost all, had long narrow skulls: their faces were commonly oval, their features regular, and their noses aquiline: most of them were of middle height, and their limbs, as a rule, were rather delicate than robust. Men with the same physical characters lived contemporaneously in Gaul and the Spanish peninsula, and are still numerous in the basin of the Mediterranean; and the race to which they belonged is often called the Iberian, though there is no reason to believe that its British representatives belonged to the Iberian rather than to some other branch of the Mediterranean stock. But it is remarkable that while early in the Neolithic age Gaul and Spain, as well as Central Europe, were overrun by invaders of a totally different kind, who were extremely short and sturdy and had broad round heads, there is no evidence that men of this race reached Britain until the very end of the [Neolithic] period, and then only in comparatively small numbers. One would be inclined to infer that tribes of the Mediterranean stock began to migrate into Britain before many of the round-headed race had settled in Gaul. Vain attempts have been made to trace the [Neolithic] migration to its original starting-point by the distribution of the dolmens, or rude stone sepulchres, which are found in many European countries. . . . Everything points to the conclusion that the earliest dolmen-builders of Britain retreated from Gaul before the sturdy round-headed invaders; and it is useless to inquire whether the Mediterranean stock, to which the British, like the earlier French dolmen-builders, belonged, originated in Europe, in Asia, or in Africa. We only know that the oldest traces of the race were discovered in the Riviera."

At this point the author refers to certain philologists, who, like Prof. Morris-Jones, see in the syntax of the Neoceltic languages the influence of a language akin to the Hamitic dialects of Africa, with which it may be supposed to have come in contact after the advent of the Celts to Britain. He asks (p. 405) why it may not have been affected by some such contact before their arrival here. Doubtless that question occurred to Prof. Morris-Jones, but he was probably prevented from answering it in the way which Dr. Holmes would seem to suggest by the fact that there are some sentences of Continental Celtic extant, and that they show few traces, if any, of the non-Aryan syntax referred to. Whether Dr. Holmes noticed that difficulty does not appear, but if he is right in saying that the Neolithic short-heads chased the "Iberians"

—a French historian would probably say "Ligurians" —across the sea to Britain, the difficulty is perhaps removed.

Perhaps the most valuable pages of the book are those in which he demonstrates that the short-headed race was not Celtic. He represents it as wholly different in physical type from the aborigines of Mediterranean stock whom it began to invade in the Neolithic age. Following the lead, if we mistake not, of the ceramic studies of Mr. Abercromby, he treats it as coming "from the Netherlands, from Denmark and its islands, perhaps also from Scandinavia and from Gaul." He gives the following description of it (p. 127):—

"Those immigrants have often been described as tall, stalwart, round-headed race; but the evidence of sepulchral remains shows that they sprang from various stocks. Those of the type which is commonly regarded as specially characteristic of the Bronze age were taller and much more powerfully built than the aborigines: their skulls were comparatively short and round; they had massive jaws, strongly marked features, enormously prominent brow ridges and retreating foreheads; and their countenances must have been stern, forbidding, and sometimes almost brutal. Similar skulls, which have much in common with the primitive Neanderthal type, have been exhumed from neolithic tombs in Denmark and the Danish island of Falster. But the skeletons which have been found in some of the oldest Scottish cists belonged to men whose average height, although they were sturdy and thick set, was barely five feet three inches, and whose skulls, shorter and rounder than the others, as well as their milder features, proved that they were an offshoot of the so-called Alpine race of Central Europe, of which there were numerous representatives in Gaul. Again there were tall men with skulls of an intermediate type; while others, who combined harsh features and projecting brows with narrow heads, and whose stature was often great, would seem to have been the offspring of intermarriage between the older and the newer inhabitants. Not a single skeleton of the characteristic British round-barrow type is known to have been discovered on French soil: the round-headed inhabitants of Gaul were as conspicuously short as those of Britain were generally tall."

The short-headed invaders began to arrive in comparatively small numbers before the end of the Neolithic age, and bands of them "landed successively through long ages upon our eastern and southern shores" after the Bronze age set in (p. 127); but "there is no evidence that the brachycephalic people who built round barrows ever reached Ireland, at least in appreciable numbers" (p. 432). They seem to have intermarried with the Neolithic aborigines, and possibly in the course of ages they gave up their language in favour of the latter's. In any case, these conclusions would, to all intents and purposes, concern the eastern and southern coasts alone, which are not represented by any known Celtic language, living or dead. So it would be idle to suggest that, in case the language of the short-heads became firmly established here, its influence on subsequent Celtic on our southern and eastern coasts might be very different from that of the language of the Neolithic aborigines more to the west, let us say, on the syntax of Irish and Welsh; for the evidence is wanting in the shape of a Celtic

speech embodying the results of the modifying influence in question. Dr. Holmes applies the term aborigines to the populations of Mediterranean stock that were here from the beginning of the Neolithic age, and extends that stock to Ireland (pp. 64, 109, 398). If, as we believe, he is right in his treatment and distribution of these people whom he claims to call the aborigines, it would be natural to suppose them to have left their name to the islands of our archipelago. We allude to the name underlying that of *Περαιωνία* *Njōu* or Pictish Islands. Dr. Holmes will have none of this: he declines to admit that "the Picts represented that race in a special sense" (p. 409). For him "the Picts were a mixed people, comprising descendants of the Neolithic aborigines, of the Round Barrow race, and of the Celtic invaders" (p. 417). This conclusion leaves us not a little puzzled, not only as to how he distinguishes between his last-mentioned Celtic invaders and the main body of Celtic settlers, but as to how he proposes to settle the question of the distribution of his mixed people in the British Isles.

He has exposed with relentless industry all kinds of inconsistencies and mistakes in the theories to which he is opposed, and thereby has rendered great service to the history of ancient Britain. For all that, he is not at his best when teaching their business to the mistaken individuals who set out to study Celtic philology. His usual method is to pit the views of one against those of another, and in the case of views which he cannot accept himself he makes use of all the resources of his critical skill: not invariably so, however, with views which fall in with his own. Thus he virtually denies that ancient Irish had the sound of *þ*, and states (p. 411) that M. d'Arbois de Jubainville "reminds his opponents, that *þ* is absent from all Ogam inscriptions." This would not be true, as it occurs not less than a score of times in Ogam, and—a fact which excludes doubt as to the sound meant—two of the names which have it happen to be the Latin Pompeius and Turpillius. This statement surprised us not a little, as the learned Frenchman has not been known to devote much attention to Ogam inscriptions. On perusing the review in which he is represented as making his sweeping assertion, we discover that it is conspicuous by its absence. What he did say was that *þ* is not found in the Ogam alphabet, which is by no means the same thing; the distance of time between the oldest Ogam alphabet (dating from the beginning of the twelfth century) and the oldest Ogam inscription containing a symbol for *þ* may be put down as ranging from five to seven centuries. Dr. Holmes could if he liked have been more accurate, and at the same time leave M. d'Arbois de Jubainville's opponents with plenty of difficulties to engage their attention.

To take another instance, the author uses the following words (p. 421):—

"According to Bede, the place which marked the western termination of the wall of Severus was called in Pictish *Peanfahel*. *Pea*n is commonly identified with the Welsh word *pen*, 'a head'; and accordingly it has been inferred that Pictish was 'a Kymric or

semi-Kymric dialect.' Mr. Nicholson, on the other hand, claims to have shown that *Peán* is 'a Goidelic borrowing from the Latin *penna* or *pinna*.'

The astonishing allusion here to the western termination of the wall of Severus might seem at first sight to be a mere misprint for *eastern*; but, on looking at the original, it turns out to be something more, something calculated to create serious uneasiness as to other statements which one has not had time to verify in this volume. Bede's words, as given in Plummer's edition, I. xii. (p. 26), run thus:—

"Incipit autem duorum ferme milium spatio a monasterio Aebbercurnig ad occidentem in loco, qui sermone Pictorum Peanfahel, lingua autem Anglorum Penneltun appellatur; et tendens contra occidentem terminatur juxta urbem Alcluiuth."

Dr. Holmes rightly acquiesces in the view that *fahel* is an old form of the Irish genitive *fáil* matching a nominative *fál*, "a hedge, a wall"; but this does not, to say the least of it, help the theory that Pictish phonetics were like those of Welsh rather than of Gaelic. As to Bede's *peán* from Latin *pinna*, the author proceeds to show how absurd it is to think that this word "could beget a geographical name." In any circumstances whatsoever, that sort of statement must be hard to prove, so the argument comes dangerously near mere quibbling, and the appeal to Cæsar should have been an appeal to the German Diez, who derives from Latin *pinna* ("Zinne der mauer") the Italian *penna*, "the top, height, or peak of a hill or mountain," and the Spanish *peña*, "a rock, a cliff," instances of which Diez finds in the oldest Spanish records as Latin *penna*. This is not all; a passage in the second volume of Stokes and Strachan's "Thesaurus Palæohibernicus," from a famous Irish MS. written in the early years of the ninth century, has the words a *pinna montis Berbicis usque ad montem Mis*. The latter height was probably Slemish Mountain, in co. Antrim; the Top of the Mountain of the Wether (*vervex*) remains to be identified. But its name in the Book of Armagh shows that *pinna* was current in Irish Latinity, and was capable of forming part of a place-name. From Latin it passed into the Goidelic language, whence Bede's *Peán-fahel*, which is accordingly neither Kymric nor even semi-Kymric. One of the case forms of a feminine *pinna* in modern Irish would be *pinne*, and it was known to O'Reilly, who gives it in his dictionary as a feminine meaning "the summit of a hill or headland."

The foregoing instances will serve to show that the author has not been quite happy in his treatment of the philologists; whether he has been happier with the geologists and astronomers, the ethnologists and archæologists, they could best tell. We regret to be unable for want of space to pass under review the rest of the second part of the work: we have drawn on the excursus treating of the ethnology of ancient Britain. There are others, however, on such attractive subjects as the Cassiterides, the configuration of the coast of Kent in the time of Cæsar, Portus Itius, the place of Cæsar's landing in Britain, and many minor themes. The Clarendon Press has done

its part with its wonted success, and the reader has the aid of useful maps, together with good illustrations. As to the work as a whole, one may say that, in spite of certain grave defects and a uniform lack of originality, it is a great monument to the author's industry.

LINEAR ALGEBRA.

Synopsis of Linear Associative Algebra. By J. B. Shaw. Pp. 146. (Washington: Carnegie Institution, 1907.)

THIS work serves three purposes: it gives a bibliography of the subject; a synopsis of the various algebras considered, in a fairly uniform notation, with a classification into families and types; and, in the introduction and § xiii. especially, some general remarks on algebra and its development. Part iii. (pp. 113-134) deals with applications.

Prof. Shaw points out that there are two views of complex algebra:—

"the one regards a number in such an algebra as in reality a duplex, triplex, or multiplex of arithmetical numbers or expressions; . . . the other regards the number in a linear algebra as a single entity, and multiplex only in that an equality between two such numbers implies n equalities between certain coordinates or functions of the numbers."

On this it may be remarked that both views are equally legitimate, and equally useful, but in different ways. The formulæ of a special algebra which are most characteristic and most powerful are those which most naturally associate themselves with the second point of view; an example is afforded by the quaternion formula $V(aV\beta\gamma) = \gamma Sa\beta - \beta Sa\gamma$. On the other hand, the place of quaternion algebra among its fellows is most clearly shown when we consider a quaternion as a complex (a, b, c, d) of four ordinary numbers, with rules for the addition and multiplication of two such tetrads.

The general impression produced by reading the synopsis is that, after Grassmann and Hamilton, the most remarkable work has been done by Benjamin Pierce. By developing his methods it has been possible to make a classification of linear associative algebras which, so far as it goes, is really exhaustive, and may be said, also, to be a natural classification. Of recent papers, those of Cartan, Frobenius, and Poincaré deserve particular mention; they tend to show that the characters of special algebras can be included in the all-embracing theory of groups.

A few lines (p. 18) are given to a definition of complex numbers by Mr. Bertrand Russell, in terms of logical constants. This is certainly interesting from a philosophical point of view, but it illustrates a tendency on the part of what may be called the Peano school to over-refine their definitions, and become verbose if not tautological. When the theory of real numbers has been logically established, it is sufficient to define a complex algebra in arithmetical terms, without bringing in logical notions already used in defining number and arithmetical operations. Why not make use of a symbolism which has been fully

justified, and which immensely abbreviates the statement of new definitions? After all, Mr. Russell's definition, as here given, does not differ essentially from the "umbral" definition (the first of the two previously referred to).

The synopsis is so condensed that it appeals rather to specialists than to general readers. The latter, if interested in the subject, will find it easier to read the more important papers referred to on pp. 5-7, and then gain a comparative view by studying the synopsis.

Prof. Shaw himself has made various contributions to the subject, some of which are contained in the present volume. His summary will doubtless do much to further the study and comprehension of algebra in general.

G. B. M.

MEDICAL PHYSICS.

Lehrbuch der medizinischen Physik. By Prof. H. Boruttau. Pp. viii+282. (Leipzig: Johann Ambrosius Barth, 1908.) Price 8 marks.

THIS book is intended for medical students who have completed a course of general physics, and is therefore limited to the study of the physical properties of tissues, the physical changes that take place in the tissues, and physical instruments of importance in physiology and pathology. In view of the slight equipment of most medical students in mathematics in Germany, as in this country, the treatment of the subject is not mathematical, diagrams and simple equations alone being used. Considering the variety of the subjects treated, the book is of very modest size. This result has been attained by keeping theoretical discussions within the narrowest limits, avoiding detail in descriptions of practical methods and apparatus, and by the use of small but excellent diagrams.

According to the author, no similar book to this has been published since that of Adolf Fick, the last edition of which appeared more than twenty years ago. As the scope of the book is therefore unusual, a brief account of its contents may be useful.

Chapter i. is introductory. Chapters ii. and iii. are devoted to the general properties of tissues, which are divided into fluids and solids, and include sections on velocity, energy and its transformations, density and elasticity of the different tissues, contraction of muscle, the levers of the body, locomotion, deformities, blood pressure, pulse, blood flow, surface tension, viscosity, osmotic pressure, and the secretion of urine. Chapter iv. deals with gases in relation to blood and respiration; chapter v. sound, including wave motion, the analysis of sounds, hearing, speech, percussion, and the sounds of respiration and the heart; chapter vi. heat production and temperature, and their relation to food, work and surface of the animal, conductivity of clothing materials, and the laws of thermodynamics; chapter vii. magnetism and electricity: therapeutic use of electricity, the electric properties of muscle and nerve, Röntgen rays, radioactivity, N-rays; chapter viii. optics: photometry, mirrors, lenses, the eye, optical measurements, cor-

rection of optical defects, the microscope, immersion lenses, polarimetry, spectroscopy, calorimetry. References to original papers are given.

A feature of the book is the inclusion of many tables of physical quantities, e.g. comparative velocities, densities and elasticities of tissues, specific rotations, conductivities of clothing materials.

That the book contains much useful information not usually found in medical students' text-books is undeniable, the section on blood pressure and pulse, and that on the respiratory murmurs, for example, but it is doubtful whether measurements of elasticity of tissues, to which considerable space is devoted, are of much value, owing to the fact that these tissues show great variations according to their nutrition, and that no tissue except bone is a true solid.

In conclusion, it may be doubted whether a book of this kind, dealing mainly with physiological subjects from a physical point of view with a physical classification, is entirely desirable. Physiologists, after a large number of careful researches on the physical phenomena of living tissues, have had to confess that they are no nearer to the discovery of a physical basis of life. The student should, therefore, arrive at a truer view of the present position of the science from books, which deal with the properties of the living organism as a whole, or as an association of different organs, than from a book with an essentially physical treatment such as this.

J. H. R.

OUR BOOK SHELF.

Musée ostéologique; Étude de la Faune Quaternaire, Ostéométrie des Mammifères. By E. Hue. Two vols. Pp. xix+50+186 plates. (Paris: Schleicher Frères, 1907.) Price 24 francs.

To persons interested in cavern-research and cavern-animals, and having no means of access to a museum, these volumes—which are a monument to the industry and perseverance of their author—will no doubt be welcome, and afford adequate means of identifying their "finds" with comparative ease. In this country, however—apart from what may be the case on the Continent—the number of such persons must, we should surmise, be extremely small, and the sale of the work consequently limited. On the other hand, it may possibly be found of use to students of comparative osteology generally, without reference to cavern-research.

The plan adopted by the author is to take the skeletons of all the species of mammals the remains of which are commonly found in caverns, and to arrange their component elements in corresponding series, so that all the skulls, all the humeri, &c., are brought together in associated plates. Each bone (except, of course, those of the skull) and each tooth is figured separately to scale, the scale in the case of each plate being as large as circumstances permit. By means of these figures to scale and measurements, Mr. Hue is of opinion that it will be practicable for anyone to identify such cave-bones—even when imperfect—as may come under his observation.

For this purpose a series of measurements for each bone in the skeleton is recommended, the lines along which these measurements should be taken being indicated in a series of preliminary figures. By the aid of a rule and pair of compasses, such measurements

can be compared with the corresponding dimensions of the specimens figured.

As the entire work is practically an atlas (the text, which is almost solely concerned with the methods of measurement, occupying only fifty pages), there is really no field for criticism. The figures, though perhaps a trifle crude, appear to be very accurate, and even in the case of the smaller teeth the details of structure are fairly well apparent. Practically the only criticism we have to make is that in plates 33 and 35 the last two upper molars of the jackal and Arctic fox are placed in positions different from those they occupy in the jaw, whereas in the case of the dog (plate 32) and fox (plate 34) they are correctly orientated. The work must have involved an enormous amount of labour, and the author is to be congratulated on the manner in which he has carried out what could scarcely have been anything else but a wearisome task.

R. L.

The Children's Book of Stars. By G. E. Mitton. Pp. xii+207; illustrated. (London: Adam and Charles Black, 1907.) Price 6s.

As a book for the instructors of small children, this volume should prove useful. As a book for the unaided juvenile, we fear that the "conventional phraseology" which the author deplors in ordinary text-books has not, even here, been sufficiently eliminated. It is, indeed, a very difficult matter to escape wholly from this evil when instructing juveniles, but, on the whole, the writer of the work under notice has succeeded admirably.

The arrangement of the matter is on familiar lines. The earth, the moon, the planets, the sun, comets, meteors, constellations, stars, and nebulae are successively treated, concisely and clearly. The analogies by which the different points are illustrated are generally well chosen and apt, and are likely to be easily understood by the young people to whom they are expounded. The chapter (xii.) on "What the Stars are made of" appears to us, despite the relative difficulty of the subject of spectrum analysis, to be one of the simplest in the whole book. The volume contains but very few mistakes, though it is curious that the one in this chapter, on p. 169, should have been overlooked. In describing the preceding plate, which shows the coloured spectra of the sun and Sirius, the latter is called Arcturus, although on the plate and later in the same paragraph it is correctly named.

The illustrations are striking, the majority of them being printed in colours, but we fear that the juveniles to whom some of them would appeal would be hopelessly at sea if given the book to read by themselves. Whilst we are doubtful as to the value of the book if used in this way, there can be no doubt that to children of older growth who have young minds to train it will fill a gap, enabling them—with a few hours' start—to answer clearly all those questions which are bound to be asked if the previous instruction has been at all successful.

W. E. R.

Cradle Tales of Hinduism. By Sister Nivedita (Margaret E. Noble). Pp. xv+343. (London: Longmans, Green and Co., 1907.) Price 5s. net.

MISS NOBLE, urged by an enthusiasm for modern Hinduism as preached in Bengal which is shared by few of her countrywomen, has edited a pleasant selection of the classical religious tales of India. She divides them into several cycles—snake tales; the story of Siva; Indian wifehood, including the famous tale of Nala and Damayanti; selections from the Mahabharata and Ramayana epics; the adventures of Krishna; tales of the devotees and of great kings. The tales, of course, are derived from a literature

familiar to all scholars, and Miss Noble would perhaps have done more useful service to folk-lore by collecting some of the great mass of folk-tales hitherto unrecorded. Her version is pleasant and interesting, but we are doubtful of the prospects of its success in English nurseries.

These stories exhibit too much of the dreamy mysticism of the East, and while largely occupied with phases of religious feeling, possess too little of that spirit of pure adventure which our children in their fairy-tale books are accustomed to expect. To those unfamiliar with classical Hindu religious literature they will form a useful introduction. The reader, however, will be well advised to accept these versions with some reservation, for a double reason. In the first place, there is too much of the Bengali spirit in them; secondly, all the eroticism and coarseness which are unhappily so prominent in this literature, and especially in that characteristic of Bengal, have necessarily been rigidly suppressed, and the student who reads these stories for the first time may be led to form an impression of their delicacy and purity of sentiment which will soon be dissipated on acquaintance with the originals.

The author, again, has hardly kept herself in touch with recent folk-tale study in India. In discussing the Krishna cycle, she appeals to native scholars for the dissection of the varied elements out of which it has obviously been composed. Here she is likely to be disappointed, because critical analysis of a sacred literature of this kind is hardly to be expected from faithful believers. If she had been aware of recent contributions to this subject, such as Mr. J. Kennedy's essay in a recent number of the *Journal of the Asiatic Society*, and other earlier studies of the same kind, she would probably have modified the rather crude suggestions contained in her preface. Hinduism possesses many merits of its own, but its claim to the attention of the West will not be advanced by carefully ignoring its most prominent characteristics.

Lehrbuch der mikroskopischen Technik. By Dr. Bernhard Rawitz. Pp. viii+438. (Leipzig: W. Engelmann, 1907.) Price 12 marks.

THIS book gives a very complete summary of modern methods employed in microscopical research as applied to animal tissues. The introductory chapter on the microscope is very brief; probably the author considered this part of the subject hardly came within the scope of his compilation. On the other hand, the preparation of material, hardening, embedding, and staining are dealt with at considerable length, and in the second part of the work the application of the methods to particular tissues and organs is detailed in a complete and thorough manner. When treating of apparatus, the author has avoided anything which simulates a list from instrument makers' catalogues, often a difficult matter in a work of this kind.

General staining methods occupy some sixty-five pages, and here we find an extremely useful summary of the uses and application of a large number of stains. Naturally German methods occupy the forefront, and the British reader misses references to such well-known modifications of the Romanowsky stain as the Leishman and the Wright.

In the second part every tissue and organ is separately considered, and the particular methods applicable in each case are detailed at greater or less length. Thus the nervous system has some seventy pages allotted to it. Little or nothing of importance seems to have been omitted from the book, which is adequately indexed, and should form a very useful compendium for the laboratory.

R. T. HEWLETT.

LETTERS TO THE EDITOR.

[The Editor does not hold himself responsible for opinions expressed by his correspondents. Neither can he undertake to return, or to correspond with the writers of, rejected manuscripts intended for this or any other part of NATURE. No notice is taken of anonymous communications.]

The Presence of Water Vapour in the Atmosphere of Mars.

In February and March, 1908, Mr. V. M. Slipher succeeded in photographing the lines due to water vapour in the atmosphere of Mars. It was in the "a" band that its presence stood revealed. The detection was rendered possible by the use of plates specially prepared by him for the purpose—23 Seed, bathed in a mixture of pinacyanol, pinavefcol, dicyanin, water, and ammonia—which enabled the spectrum to be photographed somewhat beyond the "A" band. Comparison spectrograms were made of the moon at approximately the same altitude on the same plates, and with exposures to give a like density for both. Repeated plates of the sort were taken, and their consensus shows unmistakably the "a" band stronger in the spectra of the planet than in those of the moon. In the case of the moon, of course, we are looking through our own atmosphere only; in the case of the planet, through its atmosphere as well.

Previous observers—Huggins, Jansen, Vogel, Campbell—had reached discordant conclusions, Huggins and Vogel asserting the presence of water vapour in the atmosphere of the planet, Campbell with much improved spectroscopic means failing to get any indication of it. The reason of this was the instrumental inability at the time these researches were made to examine the spectrum sufficiently far into the red, for it is in the "a" band that the greatest absorption of water vapour occurs, and this was not only beyond the possibility of photography at the time, but beyond even that of visual detection. Thus Vogel went no further redwards than "C," while Campbell tells us in his account of his researches, in which he came to a negative conclusion:—"It is impracticable to observe the groups A, 7450 to 7160 and 7160 to 6870, which are at the extreme red end of the spectrum, and they will not be further considered." In this omission, rendered necessary by the instrumental appliances at the time, lay the failure to perceive the evidence of water vapour in the spectrum of the planet. For, as the following table shows, the intensity of the absorption is much greater in the "a" band than in the lines between it and the D lines, or even in those near the D lines themselves. This is borne out by examination of Mr. Slipher's plates, in which the difference in the "a" band is evident, the broadening of the D lines just perceptible, and nothing predicable of the fainter water-vapour lines.

Relative Strength of the Water-vapour Lines in the Spectrum, according to Rowland.

Substance	Determination 1893.		Determination 1895.		Wave-length
	Lines probably identified	Lines certainly identified	Lines probably identified	Lines certainly identified	
A 7604 ... Oxygen ...	120	120	—	—	7672 } 7594 }
a 7165 ... Water Vapour ...	124	50	128	—	7319 } 7176 }
"	9	—	6	—	7016 } 6999 }
"	42	13	54	—	6948 } 6936 }
B 6867 ... Oxygen ...	170	—	—	—	6867 } 6572 }
C 6562 } Solar, H ₂ }	Water Vapour ...	5	5	20	6480 } 6296 }
a	Oxygen ...	14	—	—	6278 } 5977 }
"	Water Vapour ...	2	2	10	5920 } 5884 }
D ₁ 5896 } D ₂ 5890 }	"	26	26	68	5884 }
(Solar, Na)					

No water vapour lines of less wave-length than 5884.

NO. 2009, VOL. 77]

The great dryness of Arizona was no less a factor in the result. So dry was the air at times during the investigation that on more than one plate the "a" band is hardly to be made out in the lunar spectra, while in the Martian it is unmistakable. Great dryness in the climate is in other ways shown by the plates to be essential to the recording of a perceptible difference between the water-vapour lines due to Mars and the earth and those due to the earth alone. For examination of the oxygen bands, A, B, and a, in the two spectra reveals no perceptible difference between them, and yet the presence of water vapour in the spectrum of Mars is strong presumptive evidence that free oxygen exists in its atmosphere as well, since it is the heavier of the two.

PERCIVAL LOWELL.

Lowell Observatory, Flagstaff.

The Condensation of Helium.

I HAVE just read with great interest of Prof. Onnes's experiments with helium, and as one who has carried out investigations at very low temperatures, and to a certain extent in the same direction, I must congratulate him on having overcome difficulties of no ordinary nature. At the time of my departure for India I was engaged in an attempt to measure temperatures below the temperature of solid hydrogen, with the ultimate object of determining thermal constants for helium, but the work was broken off when I left Bristol, and it is not likely that I shall be able to resume it for some time. However, it is possible that brief information as to the method I intended to employ may be of use to others.

The measurement of low temperatures by any means other than by the gas thermometer appeared to me to be mere waste of time, and I decided to employ in these experiments a constant volume helium thermometer. Following the method of Olszewski, I proposed to compress helium to about 100 atmospheres in a vessel cooled in solid hydrogen, and containing the thermometer, and to measure the fall of temperature on expanding the gas. The only obvious difficulty lay in the construction of the apparatus.

The apparatus shown about natural size in the figure was made for me by Messrs. A. Hilger. The outer vessel was of thin steel, and had a capacity of about 40 c.c. Within were three concentric test-tubes, made as light as possible, and separated one from the other and from the steel vessel with fragments of cork. In the centre is a very light bulb of steel, to which was soldered a capillary steel tube such as is used for hypodermic needles. This bulb was intended to serve as a thermometer, the steel tube communicating with the manometric portion of one of the thermometers which I employed in the measurements of the temperatures of liquid and solid hydrogen (Phil. Trans., cc. A, 105, 1902). A steel tube connected the steel vessel

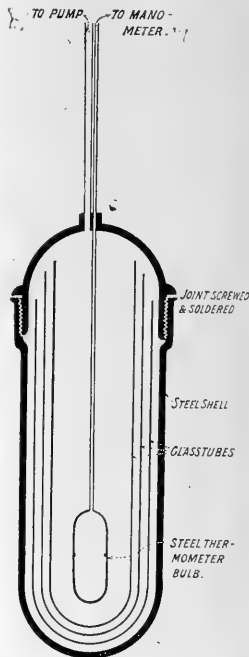

with the pump, &c. A steel gasometer floating on mercury, and a steel pump working with mercury as a lubricant, had also been constructed for me by Messrs. Brin's Oxygen Co. Sir William Ramsay had placed a large quantity of helium at my disposal.

Preliminary experiments with oxygen led me to the conclusion that by this method it would be possible to attain to, and measure temperatures far below, the melting point of hydrogen. I may point out that for very low temperatures the reading of the manometer attached to the thermometer would give a direct measurement of the temperature, as the dead space correction would be very small.

MORRIS W. TRAVERS.

Indian Institute of Science, Bangalore, March 29.

The Radio-activity of Ordinary Metals: the Penetrating Radiation from the Earth.

In a paper in the *Phil. Mag.*, December, 1907, I described some experiments made by me on the conductivity of air confined in metallic cylinders, 60 cm. long and 24 cm. in diameter, which were made of lead, of zinc, and of aluminium. With the zinc and aluminium carefully cleaned, a conductivity was obtained for the enclosed air, which on reduction gave the value 13 for q , the number of ions generated per c.c. per second in the air. With lead cylinders, which were investigated more extensively than those of other metals, the conductivity exhibited wide variations, and values were obtained which ranged from 160 to 23 ions per c.c. per second.

During the past eight months experiments on the conductivity of air confined in metallic vessels have been continued in the Physical Laboratory at Toronto by Mr. C. S. Wright, and he has now obtained under normal conditions with a particular lead cylinder of the dimensions given above, in a series of observations made in a room in the laboratory, a conductivity corresponding to the production of 15.3 ions per c.c. per second. With zinc and aluminium cylinders, the lowest conductivities obtained in this room by him correspond, respectively, to the values 13.4 and 12.5 ions per c.c. per second for q .

He has also, during this period, conducted a series of experiments on the conductivity of air enclosed in these cylinders in and about Toronto, and has found that the conductivity of the enclosed air varied considerably with the character of the soil and rocks in the neighbourhood of the points of observation.

In making measurements on the ice above the water of Lake Ontario, the conductivity was found to be very much lower over the surface of the water than at points on the land on either side of the lake at some distance from the shore. In these experiments on the ice the values 8.6, 6.0, and 6.55 ions per c.c. per second were found for q with cylinders of lead, zinc, and aluminium respectively, and in a more extended series of observations with the lead cylinder alone, the conductivity was found to be the same over water with depths varying from 2.5 to 10 metres. Measurements were also made on board the steamer *Corona* during one of her passages over the lake, and values were obtained for q uniformly lower by approximately 6 ions per c.c. per second than those found in the laboratory at Toronto, although the depth of the water at the wharf in Toronto, where the observations in this series were commenced, was not more than 6 or 7 metres, while it was approximately 150 metres in depth at the deepest point on the line of passage.

Observations made on a sand bar extending out into the lake near Toronto gave a value of 9 ions per c.c. per second for q , and others made on land, at some distance from the shore, at various points and over different soils, gave values ranging from 11.2 to 15 ions per c.c. per second.

From the investigation it would appear that the water of Lake Ontario, as well as the sand along the shore line, contains little, if any, radio-active materials, and consequently does not contribute any appreciable proportion of the penetrating radiation observed at points on the earth's surface.

It would appear, too, from the constancy of the observed

drop in conductivity that the water of the lake completely screens off any radiation coming from the soil or rock beneath it. In order to confirm this view, some experiments were made on the absorbing power of the water for the γ rays from radium. Thirty milligrams of radium bromide were enclosed in a brass tube with walls about 1 cm. thick. This tube was laid on the ice, and the ionisation chamber placed 113 cm. above it. With this arrangement it was found that the conductivity added by the radium bromide corresponded to the generation in the air in the chamber of 4485 ions per c.c. per second. A hole was then made in the ice, and the tube was lowered to different depths in the water beneath, the conductivity being measured for each position of the radium. At a distance of half a metre below the surface the conductivity corresponded to the production of 447.2 ions per c.c. per second, at 1 metre to 16.11, at 2 metres to 0.69, and at 3 metres to 0.62 ions per c.c. per second. From these numbers it will be seen that a layer of water between 2 and 3 metres in thickness sufficed to absorb practically all the radiation issuing from the radium in the tube.

In view of these experiments and of those of Elster and Geitel, who observed a fall of 28 per cent. in the conductivity of air enclosed in an aluminium cylinder, on taking this cylinder from the surface of the earth to the bottom of a mine surrounded with a wall of rock salt, it would seem that the penetrating radiation observed by a number of investigators at the surface of the earth is more or less local in character, and that, while its existence may be traceable to active substances present in the soil and rocks, the effective intensity is largely determined by the amount of inactive substances it may have to pass through in order to reach the surface.

The extremely low values found for q with the cylinders of lead, zinc, and aluminium in the experiments on the ice are interesting on account of their uniformity. They are, as is evident, of the order of magnitude of effects which might easily be accounted for by active impurities in the metals, since differences as large as these values of q may easily be obtained with cylinders made from different samples of almost any metal selected at random. Considering also the difference in the atomic weights of the three substances aluminium, zinc, and lead, and having in mind that radio-activity is a property associated with atomic structure, it would seem that if these metals could be obtained entirely free from active impurities, and the conductivity of air contained in vessels made from them studied, it would be found, if the observations were carried out under conditions or in places where no ionisation was possible from penetrating radiations arising from external sources, to drop to a very low value, if it did not entirely vanish.

The experiments described in this note were made with one of Mr. C. T. R. Wilson's latest type of gold-leaf electrometers, which was found, on account of its portability, and of the facility and exactness with which readings could be made with it, to be most admirably suited to the purposes of the investigation.

J. C. McLENNAN.

Physical Laboratory, University of Toronto,
March 30.

The Theory of Dispersion and Spectrum Series.

ON p. 413 of NATURE (March 5) Prof. Schott attempts to show that there is an irreconcilable inconsistency between Drude's dispersion formula and Balmer's formula for the lines in the hydrogen spectrum. I imagined that someone who could speak with greater authority than myself would make the obvious reply, but since no such reply has been forthcoming, and the arguments have been republished in another journal, I venture to ask for space to point out why they appear to me fallacious.

Prof. Schott's error consists in assuming that the λ_n in Drude's formula is the same as the λ_n in Balmer's formula. The λ_n in Drude's formula is the wave-length of the light for which the medium shows selective absorption; that in Balmer's formula is the wave-length of the light emitted by the gas when in a luminous state. An unintelligent

application of Kirchhoff's law sometimes leads students to imagine that the two quantities are identical, but Kirchhoff's law applies only to purely thermal radiation (*cf.* Wood's "Physical Optics," chapter xix.). A gas, such as hydrogen, in its non-luminous condition does not absorb selectively the light emitted by luminous hydrogen. I do not think that any absorption bands in non-luminous hydrogen have been detected; they are probably far in the ultra-violet, and there is no reason for supposing that their wave-lengths will be connected by any formula similar to that of Balmer.

The reason for the difference in the frequencies of the absorption bands and the lines in the emission spectrum is sufficiently obvious. The emission of light by a gas is doubtless connected with the ionisation of its atoms. But, when an atom is ionised, the electrons in or surrounding that atom are subject to forces entirely different from those which act upon them when the atom is ionised; there must be a corresponding difference in the periods of free vibration. The absorption bands probably represent the vibrations of the electrons in the neutral atom, the emission spectrum those of the electrons in or around the ionised atom.

Nor is there any reason why the refractive index of a luminous gas should differ greatly from that of a non-luminous gas, except in the immediate neighbourhood of a line in the emission spectrum. (It is relevant to note that Drude's formula cannot be applied to such regions.) Only a very small proportion of the total number of atoms present is ionised even under the most favourable experimental conditions; most of the atoms are not ionised, and affect the light in the same way as those of a non-luminous gas. Of course, if the refractive index due to the luminous atoms were really infinite, the refractive index of the luminous gas would be infinite, however small the proportion of luminous atoms. But it is impossible that it should be infinite; if Balmer's formula were accurately true for all values of m , there would be an infinite number of lines in the emission spectrum, implying an infinite number of degrees of freedom in the vibrating system. According to the modern view, which seems to be accepted by Prof. Schott, this system is composed of discrete charged particles possessing a finite mass; the number of such particles must be finite, and they can only have a finite number of degrees of freedom. Experiment can never demand an infinite number of lines, for, if m is very great, the lines are so close as to be beyond the range of resolution.

NORMAN R. CAMPRELL.

Trinity College, Cambridge.

The Oligochaetous Fauna of Lake Birket el Qurun and Lake Nyassa.

IN NATURE of August 1, 1907 (vol. lxxxv., p. 316), Messrs. Cunningham and C. L. Boulenger wrote a preliminary account of the fauna of Lake Birket el Qurun. I am indebted to these gentlemen for the opportunity of supplementing their account by a note upon the Oligochaeta of that lake. They were so good as to send to me two tubes with a large number of specimens of a small oligochaetous worm collected in the lake. These specimens were found to belong, without exception, to the species *Paranis littoralis*. The occurrence of this Naid in northern Africa is a new fact in its distribution. It has hitherto been met with in many parts of Europe, both in fresh water and in brackish, even salt, water. As to its marine habitat, it has been collected on the shores of Denmark and near Odessa.

It is clear from the fact that this was the only aquatic Oligochaeta met with by Messrs. Cunningham and Boulenger that it must at least be a prevalent form in the lake.

Mr. Cunningham has also kindly placed in my hands some examples of aquatic Oligochaeta from Lake Nyassa. These belong to three species, and the contrast with the oligochaetous fauna of the North African lake is very marked. The genera represented in Nyassa are *Dero*, *Nais*, and *Pristina*. Unfortunately, none of the examples

submitted to me are sexually mature. The *Pristina* I identify with *Pristina longiseta*, a widely spread form. The genera *Nais* and *Dero* are also found in many parts of the world, and as all three genera have already been recorded from tropical East Africa (Michaelsen in *Zeitschr. f. wiss. Zool.*, Bd. lxxxii., 1905, p. 289), there is no cause for surprise at their occurrence in Nyassa. Still, the fact seemed to me to be worth putting on record.

FRANK E. BEDDARD.

Zoological Society's Gardens.

THE FORTHCOMING DUBLIN MEETING OF THE BRITISH ASSOCIATION.

THE British Association will hold its fourth meeting in Dublin on September 2-8 of this year. The three previous meetings took place in 1835, in 1857, and in 1878. The 1878 meeting drew an attendance of 2578, which was well above the average, and it was marked by the presence of an unusually large number of men distinguished in scientific or other work at the time and since. In his presidential address before the Anthropology Section, Prof. Huxley spoke prophetically about those "who may be here thirty years hence—I certainly shall not be," little realising how both his prophecies were destined to come true.

Appropriately enough (though, I believe, not consciously in connection with Huxley's forecast), the invitation for 1908 originated with Prof. W. H. Thompson, of the physiological laboratory of Dublin University. It was originally intended for 1907, but 1908 was found to be more suitable, and the invitation was formally accepted at York in 1906, where a deputation attended consisting of the Provost of Trinity College, Prof. Thompson, Dr. Tarleton, Monsignor Molloy, Rev. Dr. Delaney, and the Lord Mayor of Dublin. The invitation was formally renewed at Leicester by Prof. Thompson, Rev. Dr. Delaney, and Sir Howard Grubb. At a first meeting at the Dublin Mansion House, general and executive committees were appointed, and these have been at work ever since, with the result that the arrangements are in an advanced state of preparation. Subcommittees were appointed to deal with finance, entertainments, hospitality, and the handbook respectively. The four local secretaries are Dr. Joseph McGrath, secretary of the Royal University, Prof. W. E. Thrift, Prof. W. H. Thompson, and Mr. John Mulligan, of the Hibernian Bank. About 3000l. has already been subscribed towards the expenses of the meeting. The reduced fare tickets will be available for a month, so as to include the excursions subsequent to the official meeting. Day excursions will be arranged during the week of the meeting to the Devil's Glen and Glendalough in county Wicklow, to Powerscourt Waterfall and the Dargle near Bray, to the Boyne Valley, and to the Shannon Lakes.

The presidential address will be delivered by Mr. Francis Darwin, F.R.S., on the evening of Wednesday, September 2, in the large hall of the Royal University. Here also will be delivered two of the evening discourses, one on "Halley's Comet," by Prof. H. H. Turner, F.R.S. (Friday, September 4), the other on "The Lessons of the Colorado Cañon," by Prof. W. M. Davis, of Harvard University (Monday, September 7). The third evening discourse will be delivered to operatives on Saturday, September 5. To this discourse ordinary members will not be admitted. The lecture hall has not yet been decided upon.

The serious work of the sections will, for the most part, be over each day by two o'clock, leaving the

afternoon, and those evenings on which discourses are not held, free for entertainments of a social kind. Of the latter, not a few are already promised, including garden-parties by their Excellencies the Lord Lieutenant and the Countess of Aberdeen, by Lord and Lady Ardlau, and by the provost and senior fellows of Trinity College; evening receptions are also to be held by the Viscount and Viscountess Iveagh, by the Royal Dublin Society, and by the Royal Irish Academy. The Lord Mayor and Lady Mayoress will be "At Home" at the Mansion House, to members of the association, on the afternoon of the opening day of the meeting.

The work of the Dublin meeting will be transacted in twelve sections, which, with their respective presidents, are as follows:—Mathematical and Physical Science (Dr. W. N. Shaw, F.R.S.); Chemistry (Prof. F. S. Kipping, F.R.S.); Geology (Prof. J. Joly, F.R.S.); Zoology (Dr. S. F. Harmer, F.R.S.); Geography (Major E. H. Hills, R.E.); Economic Science and Statistics (Mr. W. M. Acworth); Subsection Agriculture (Sir Horace Plunkett, K.C.V.O., F.R.S.); Engineering (Mr. Dugald Clerk, F.R.S.); Anthropology (Prof. W. Ridgeway); Physiology (Dr. J. S. Haldane, F.R.S.); Botany (Dr. F. F. Blackman, F.R.S.); Educational Science (Prof. L. C. Miall, F.R.S.). To increase the general interest in the doings of the association, these sections have been distributed over various institutions in the city, the governing bodies of which have kindly undertaken to provide suitable accommodation. Thus, Trinity College, the Royal University, the Royal College of Science, University College, the Royal Colleges of Physicians and Surgeons, the Royal Irish Academy, and the Royal Dublin Society all vie with each other in this respect.

The reception room and administrative offices during the meeting will be located in Trinity College. Until then, offices for the local reception committee have been kindly provided at the Royal University by permission of the Senate.

The official handbook is being prepared by Mr. R. Lloyd Praeger (author of "Irish Topographical Botany") and Prof. Grenville A. J. Cole, under the auspices of the Handbook Committee. It will comprise sections on local geology, botany, zoology, history and archaeology, commerce and industries, and the usual official information. Among the articles will be one on glacial phenomena, by Mr. J. R. Kilroe, and another on mineralogy, by Mr. H. J. Seymour, both of the Geological Survey. Mr. Nathaniel Colgan, author of "Flora of Co. Dublin" and one of the editors of "Cybele Hibernica," will deal with botanical subjects. The zoology section will be prepared by Prof. G. H. Carpenter, and will comprise an essay on Irish mammals, by Dr. Scharff; birds, by Mr. R. M. Barrington (author of "Migration of Birds"); and numerous other special articles.

The history and archaeology of the district round Dublin will be in charge of Mr. C. Litton Falkiner, secretary to the council of the Royal Irish Academy, and Mr. Elrington Ball (author of "History of the 'Flora of Co. Dublin'" and one of the editors of Murray's "Guide to Ireland") will deal with the prehistoric and other antiquities of the Boyne Valley, including the famous tumuli of Knowth, Dowth, and Newgrange, and with Dublin churches. There will also be articles by Mr. J. Westropp on the mediæval and ecclesiastical antiquities of Dublin and Wicklow; by Count Plunkett, the new director of the Dublin Museum, on old Dublin houses; and by Dr. Cosgrave, on old views of Dublin.

Dublin possesses attractions which very few capital

cities can rival. Situated in the centre of Dublin Bay, its beautiful and prosperous suburbs extend northwards on to the promontory of Howth and southwards to Kingstown, Dalkey, and the far-famed Bay of Killiney, which, closed in by the Wicklow Mountains, presents an aspect of unsurpassed beauty.

A somewhat unusual element of local colour will be given to this year's Dublin meeting by the large number of bilingual street name-plates and signposts (an outcome of the Gaelic revival), on which the historic names are given in both Irish and English character and spelling. The well-known cordiality and hospitality of the Irish people may be trusted to render this year's visit of the devotees of science one of particularly agreeable memories.

E. E. F.

THE SCIENCE COURT OF THE FRANCO-BRITISH EXHIBITION.

THE fact that pure science will take a recognised part in the scheme of the forthcoming Franco-British Exhibition, and that it is being assigned a court specially for this subject, has already been recorded in these columns. It is believed that this is the first large exhibition at which such distinct recognition of the claims of pure science has been made, and it may be welcomed as being an example which should be followed at all future exhibitions.

The scheme of the court has been arranged so as to show apparatus and processes of historical value in the various sciences, and also, so far as possible, to illustrate various researches in science, both in the laboratory and in the factory, which have been and are being carried on. The exhibits will be arranged under the head of each of the great sciences, with subdivisions where necessary. Arrangements have also been made to illustrate the nature of the scientific work which is being carried on under the head of the exploration of the heavens, the air, the sea, and the land, which come naturally under the sciences of astronomy, meteorology, oceanography, geography, and geology. In this way it is hoped that a fairly complete review of all the important sciences will be obtained.

In the previous article in NATURE, the constitution and names of the full committee and of the various subcommittees were given. The preliminary arrangements and discussion of the principles to be followed, and the nature of exhibits to be asked for, occupied the committee several months, but the work of actually collecting the exhibits in each science which are to be shown was handed over by the committee to the various subcommittees and their respective Conveners, as they are the best and most appropriate judges of what exhibits are available. These subcommittees and their Conveners have really had a hard and difficult task in making representative and interesting collections, but they have, on the whole, been most successful.

The usual difficulties in securing historically valuable apparatus have been experienced, and many individuals and institutions have not found themselves able to allow such apparatus to pass out of their own custody. Further difficulties have also arisen, as is usual in such cases, in the matter of space and funds, for both have had to be provided by the exhibition itself, as no public funds have been forthcoming. The executive committee has generously given a court, comprising the space of about 14,000 square feet, free of cost, for the science exhibits, and has placed at the disposal of the science committee

sufficient funds to allow the exhibits to be safely kept and properly displayed, though perhaps the exhibits will not be shown in such lavish surroundings as might have been desired.

The arrangement of the court is shown in the sketch-plan here reproduced. The north side of the court will be mainly devoted to "Exploration," and there will be a section devoted to astronomy which will have amongst its exhibits a very complete astro-physical observatory. The other sections in this part will be devoted to oceanography, geology, and geography.

In the centre of the court there will be most interesting exhibits from the National Physical Laboratory, also in electricity and magnetism, and in mineralogy and crystallography. The south side of the court will contain the meteorological exhibits, with a typical meteorological observatory, a large exhibit in chemistry, one of metallography, one of biology, one of anthropology, and one of heat, together

amount and kind of the breakdown which accompanies vital activity, and so logically the study of katabolism must come first. This is only possible when anabolism is minimal; hence arises the importance of the knowledge of what occurs when the intake is limited to oxygen and water.

The work just published under the auspices of Dr. Benedict, the director of the Nutrition Laboratory at Boston, U.S.A., deals with this subject in a masterly way. It is a monument of prolonged and patient industry and self-sacrifice, as well as of admirably planned experiments on a large scale under careful and coordinated guidance. The book is not one which would be selected as a companion for a railway journey. It consists mainly of the protocols of the experiments, their ultimate valuation, and the general results to be drawn from them being left for the future.

A good deal of inanition work has been done in the past upon animals with useful results; a few observ-

Outside numbers = Screen space

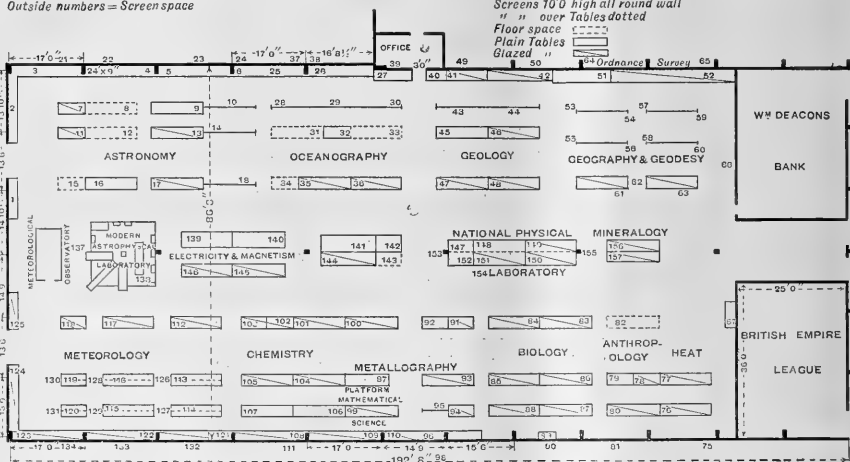

Franco-British Exhibition. Setting-out of Science Section. Building No. 11.

with smaller exhibits of mathematical science and visible and invisible radiations.

It is also hoped that a meteorological observatory actually at work will be arranged in the grounds of the exhibition.

THE SCIENTIFIC STUDY OF STARVATION.¹

TO the non-scientific mind the detailed study of inanition or starvation in men and animals may appear both useless and unnecessary. It is in reality one of the most important pieces of work the investigator of nutrition and allied problems can undertake. In the normal condition the processes of construction (anabolism) and decay (katabolism) are taking place simultaneously, and one can in that condition only obtain the net result of, or balance between, these two antagonistic phenomena. In order to understand the way in which the body builds itself up, it is obviously necessary that we should first know the

ations have been made upon men, especially upon professional fasters. In order to obtain trustworthy averages, it is necessary that such experiments should be performed upon a large number of individuals, and this is the work which Dr. Benedict has, with the assistance of his colleagues, and the voluntary self-abnegation of a number of students and others, been successful in accomplishing. Experiments on man himself are more valuable than experiments on the lower animals in such a subject as this.

During Dr. Benedict's long association with the late Dr. Atwater, the celebrated respiration calorimeter was evolved, and the generosity of the Carnegie Institution of Washington has enabled now a special laboratory, situated in Boston, to be entirely devoted to work of this kind. English workers may well envy their more fortunate colleagues across the Atlantic in the ease with which funds are obtained both for higher education and research.

Each man who entered the calorimeter chamber was almost entirely shut off from the world for periods of two, three, and, in some cases, more days. His sole connection with his fellows was a telephone; he

¹ "The Influence of Inanition on Metabolism." By Francis Gano Benedict. Pp. v+542. (Washington: Carnegie Institution, 1907.)

could read, move about to some extent, and sleep for prescribed periods. But his every action was watched through a window and recorded. There were no meals to help him pass the time, and the principal occupation of the prisoner was counting his pulse, and respiration, and carefully collecting his excreta at frequent intervals. These were subsequently analysed, and their various constituents estimated. At the same time, the amount of oxygen used, of carbonic acid and water exhaled, of heat produced, and other factors too numerous even to catalogue, were all determined and recorded. One striking outcome of the work was that in the diaries reproduced comparatively little suffering apart from ennui was recorded. The same has been previously stated by professional fasters; we can therefore hardly doubt that in animals also the actual suffering has been small when they have been subjected to the withdrawal of solid food for a few days. The book is to be commended to all interested in physiological work, and especially to those engaged in a study of nutrition.

W. D. H.

RECENT PROGRESS OF THE METRIC SYSTEM.¹

AN important report by Dr. Guillaume, presented at the meeting of the General Conference of Weights and Measures at Paris in October last, has recently reached us. Dr. Guillaume commences his report with an interesting account of some recent investigations which have been made at the International Bureau of Weights and Measures with respect to the permanency and invariability of the iridio-platinum standards of the metre and the kilogram, which were distributed in 1889 to the several States participating in the Metric Convention of May, 1875. The result of these researches is very satisfactory, and says much for the high standard of accuracy maintained in the metrological determinations of the bureau. Among other investigations which have been undertaken at the bureau since the previous meeting of the general conference in 1901, attention is directed to the work of MM. Benoît, Fabry and Perot in connection with the interferential measurement of light waves. The results obtained confirm in a remarkable manner the value found by Michelson and Benoît in 1892-3 for the length of the metre in terms of the wave-length (λ) of the red radiation of incandescent cadmium, in dry air at 760 mm. pressure, and at the temperature of 15° on the normal hydrogen scale. The new value, viz. :—

$$\text{Metre} = 1,553,164 \cdot 13 \lambda,$$

leads to the following equivalent for the length of the yard, viz. :—

$$\text{Yard} = 1,420,212 \cdot 04 \lambda.$$

These values differ from the earlier determination of Michelson and Benoît by less than one part in 10,000,000, from which it may be inferred that the interferential method of linear measurement can lay claim to a degree of accuracy far surpassing that attainable with the best micrometer microscopes.

Another important research, which has occupied the bureau for many years past and has now reached its final stage, is the determination of the weight of a given volume of pure water at its maximum density. From this investigation, which has been conducted principally by MM. Chappuis and Guillaume, the weight in *vacuo* of a cubic decimetre of water at 4° C. has been ascertained to be 0.999972 kilogram.

¹ "Les récents Progrès du Système métrique." By Ch.-Ed. Guillaume. Pp. 94. (Paris: Gauthier-Villars, 1907.)

As the weight of a gallon of water at 62° F., weighed against brass weights in air at the same temperature and with the barometer at 30 inches, is defined as being 10 lb. avoirdupois, the following value for the cubic contents of the gallon may be readily deduced from the above result, viz. :—

$$\text{Gallon} = 277 \cdot 420 \text{ cubic inches.}$$

It follows that, under the same conditions of temperature and pressure as in the gallon equivalent,

$$\begin{aligned} 1 \text{ cubic foot of water} &= 62 \cdot 288 \text{ lb., and} \\ 1 \text{ cubic inch} &,, = 252 \cdot 325 \text{ grains.} \end{aligned}$$

Further investigations on the subject are in progress at the bureau, but it is unlikely that the final results will be found to differ appreciably from those given above. The values at present legalised in this country, which are based on determinations made by Kater in 1821, are far from accurate, but legislators are naturally chary of prescribing new relations between physical magnitudes before science has said her last word on the subject.

With respect to thermometry, researches undertaken at the bureau during the period covered by this report indicate that the normal scale of temperature adopted by the international committee in 1887 is practically in perfect agreement with the absolute thermometric scale. The corrections previously determined for reducing the readings of mercury thermometers to the latter scale are found to hold good even for instruments of the most recent construction. Formerly Tonnelot thermometers were employed at the bureau in metrological determinations, and thermometers of this type were supplied with the various national prototypes which were distributed in 1889. Of recent years preference has been given to instruments constructed by Baudin, which are subjected to a preliminary course of artificial heating in the vapour of sulphur. It has been found at the bureau that thermometers treated by this process acquire almost perfect stability.

Dr. Guillaume devotes one chapter of his report to recent legislation in different countries with respect to the metric system of weights and measures. During the last few years the metric prototypes of the bureau have been legally recognised in France and Roumania, and the laws of these countries have been brought into harmony with the present conditions of metrology. In Hungary a law was recently passed defining the units of force, pressure, and density in terms of the metric system. The legislature of Denmark has provided for the adoption of the system in that country by the year 1910. The system has also been made obligatory in the Portuguese colonies. On the other hand, Dr. Guillaume does not find much progress to record in Great Britain and its colonies or in the United States, so far as legislation is concerned. Canada has, however, with the acquiescence of the British Government, formally joined the Metric Convention on the footing of a separate State, and in New Zealand an ordinance has been passed prescribing the exclusive use of the system after an indefinite date.

A resolution of the general conference urging upon the various contracting States the formal adoption of a metric carat of 200 milligrams for use in the sale of diamonds and precious stones has been brought by the several Governments under the notice of the industry concerned. At present it is not possible to anticipate what response will be made by the trade. In this country the carat is not legally recognised; but as a customary weight its value is generally accepted as being 3.1683 grains, or 151½ carats to the

ounce troy. This is equivalent to 205.3 milligrams. The carat is an extremely ancient weight, of uncertain origin so far as its present value is concerned, but it would appear to be in some way connected with the old standard of fineness for silver in England, viz., 10 oz. 2 dwt. of fine silver to the pound troy, this ratio of fineness being equivalent to the quotient of 64 grains by 24 carats.

In conclusion, it is pleasing to note the moderate tone and invariable accuracy of statement which characterise this report of Dr. Guillaume on a subject which is often discussed in print with considerable warmth.

NOTES.

A COMMITTEE has been appointed for the purpose of erecting a monument to Marcellin Berthelot by means of an international subscription. The president of the committee is M. Loubet, who is to be assisted, we learn from the *Revue scientifique*, by MM. Gaston Boissier, Léon Bourgeois, Darboux, and Lavesseur. Donations may be sent to M. Ch. Goudchaux, 16 rue Miromesnil.

PROF. R. A. S. REDMAYNE, professor of mining in the University of Birmingham, has been appointed an Inspector of Mines, under the Coal Mines Regulation Acts, 1887 to 1905, the Metalliferous Mines Regulation Acts, 1872 and 1875, and the Quarries Act, 1894, under the title of "Chief Inspector of Mines."

THE death is announced, in his seventy-first year, of Prof. Leopold Schrötter von Kristelli, professor of internal medicine in the University of Vienna, and distinguished for his work in the science of laryngology.

THE management of the Municipal Exhibition, which will be opened at the Agricultural Hall on May 1, has arranged for an installation of Röntgen-ray apparatus in a special building in the hall, and for demonstrations, illustrating its use, to be carried out at certain hours each day.

WE learn from the *British Medical Journal* that the Riberi prize, of the value of 800*l.*, which is given every five years by the Royal Academy of Medicine of Turin, has been awarded to Prof. Bartolomeo Gosio, director of the Laboratories of Public Health of the Italian Ministry of the Interior, for his studies on the bio-reaction of arsenic, selenium, and tellurium.

A BILL has been passed by the Virginia Legislature establishing a Virginia State Geological Survey. According to *Science*, the bureau is to have its headquarters at the University of Virginia, and the board is to be composed of the Governor (*ex officio*), the president of the University, the president of the Virginia Polytechnic Institute, and two citizens. An annual appropriation of 2000*l.* is provided.

AN interesting exhibit of photographs, instruments, and other astronomical objects is now on view at Cardiff Museum. It was arranged by the Astronomical Society of Wales, and was opened by the Lord Mayor of Cardiff on April 23. Much interest is being taken in the exhibition, which will remain open for some weeks. The Cardiff City Council is now taking a commendable interest in the furtherance of popular astronomy, maintaining an observatory at Penylan Hill, which houses a 12-inch reflector. This observatory is also a meteorological station of the second class.

AN appeal is being made for subscriptions to a fund for the widow and daughters of the late Mr. Gerald

Massey, whose literary works on subjects relating to myth, religion, and Egyptology are known to many readers and widely admired. A donation of 200*l.* has been received from the Royal Bounty Fund, and friends of the family have felt that this sum might form the nucleus of a fund which would yield a small income. Subscriptions will be received by Mr. James Robertson, 5 Granby Terrace, Hillhead, Glasgow, Scotland, who will render an account to all senders.

A CORRESPONDENT asks for information or references in regard to the deviation of rivers caused by the rotational velocity of the earth. Prof. G. A. J. Cole has kindly sent the following answer to the inquiry:—"The effect of the earth's rotation on the courses of rivers is regarded by many geographers as distinctly noticeable. The deflection is to the right in the northern hemisphere, the bank being, it is said, typically excavated on this side, while a shoal is left upon the other. In any series of meanders, therefore, those directed to the right side should tend to become more pronounced than those directed to the left. The reverse effects should occur in the southern hemisphere, the left bank being here eroded. Babinet and E. von Baer developed this theory in 1859 and 1860 respectively. The matter is discussed by G. K. Gilbert, *American Journal of Science*, vol. xxvii. (1884), pp. 427-32, and A. C. Baines, *ibid.*, vol. xxviii., pp. 434-6, and excellently and fully by A. Penck, 'Morphologie der Erdoberfläche' (1894), vol. 1, pp. 351-60, with numerous references and examples; a sketch is also given by I. C. Russell, 'Rivers of North America,' *Progressive Science Series* (1898), pp. 39-43. F. Wahnschaffe, who has to deal with the great rivers moving in loose materials over the Prussian plain, throws doubt, like some other writers, upon the efficacy of the earth's rotation in producing a noticeable divergence by erosion ('Die Ursachen der Oberflächengestaltung des norddeutschen Flachlandes,' 1901, p. 188)."

THE general type of weather was very wintry and unsettled during the past week, and at many places in the northern portion of the kingdom a lower minimum temperature has occurred than has been previously recorded in April for about forty years, the shade readings ranging from 18° to 22°. Much snow has also fallen in all parts of the country. The report of the weather issued by the Meteorological Office for the week ending April 25 shows exceptional conditions for the time of year. The mean temperature had a deficit of 10° in the east of Scotland and in the Midland counties, and of about 9° in many other parts of the kingdom. The absolute minima were generally registered on April 24 or 25. At Balmoral the sheltered thermometer fell to 10° on April 24, whilst on the grass the reading was as low as 4°. On April 25 the highest reading throughout the day was 35°, at Oxford, and 34°, at Cullompton and Buxton. Nearly all the precipitation took the form of sleet or snow, and the fall was exceptionally heavy in the east and south of England. At Oxford the gauge yielded 1.66 inches for the twenty-four hours ending 8 a.m. on Sunday, the depth of snow being 16 inches, whilst at Southampton the depth was 14 inches, and at Marlborough 11 inches. At Bourne mouth the snow which fell for twelve hours during Friday night yielded 1.13 inches of water, equal to about 11 inches of snow. The snowstorm on our south coast on Saturday, April 25, has been characterised as a blizzard.

WE welcome the formation of the Research Defence Society, the object of which is to make known the facts as to experiments on animals in this country. The society was formed in January last, and already numbers more

than 800 members. It is not an association of men of science or of medical men alone; its membership has been drawn from all departments of public life. Lord Cromer is the president, and a long list of vice-presidents includes the names of men distinguished in most branches of intellectual activity. The annual subscription is 5s., to cover working expenses, but larger subscriptions or donations will be gladly received. The acting honorary treasurer, *pro tem.*, is Mr. J. Luard Pattison, C.B., of the Lister Institute, and an account in the society's name has been opened with Messrs. Coutts and Co., 440 Strand. The honorary secretary is Mr. Stephen Paget, 70 Harley Street, London, W., to whom all communications should be addressed. Lord Cromer, in a letter which has been widely circulated in the Press, directs attention to the immense importance to the welfare of mankind of experiments on animals conducted with proper care, and instances, among many results which have already followed such investigations, the use of antiseptics, the modern treatment of wounds, the invention of diphtheria antitoxin, and the discovery of the causes of plague, cholera, typhoid fever, and sleeping sickness. He also explains that the society will endeavour to make it clear that scientific men who perform experiments on animals are not less humane than the rest of their countrymen who daily, though perhaps unconsciously, profit by them. It is proposed to give information to all inquirers, to publish *présis*, articles, and leaflets, to make arrangements for lectures, and to assist all who desire to examine the arguments on behalf of experiments on animals.

The structure of the epidermis and epidermal glands of poisonous fishes forms the subject of an article by Mr. E. Pawlowsky in Nos. 7 and 8 of the *Comptes rendus de la Soc. Imp. Nat. de St. Pétersbourg* for 1907. In addition to the ordinary epidermal glands, poisonous fishes like the weavers (*Trachinus*) are furnished with large serous glands of a horny structure which secrete the harmful fluid. The sting-rays (*Trygon*) have, however, a numerous series of minute poison-glands in the tail.

RECENT papers received from America include an elaborate account of the early stages in the development of the Mississippi alligator, by Prof. A. M. Riese, issued in vol. li. of *Smithsonian Miscellaneous Contributions*, and illustrated with twenty-three plates. Also notes on Guatemalan birds, by Mr. N. Dearborn, and on fishes from Mexico and Central America, by Mr. S. E. Meath, published by the Field Museum of Natural History. Schizopod crustaceans from Alaska form the subject of a paper by Mr. A. E. Ortmann, published as No. 1591 of the *Proceedings of the U.S. National Museum*; while in No. 1594 of the same, Mr. A. S. Pearse describes four new species of the amphipod group from the Gulf of Mexico, and in No. 1593 Miss Richardson records the occurrence of the parasitic isopod *Leidyia* on an entirely new host.

THE first part of vol. vi. of the *Annals of the South African Museum* is devoted to a fourth instalment of the Rev. T. R. R. Stebbing's account of South African crustaceans, of which the earlier parts were published in "Marine Investigations in South Africa." In the present part the author describes as new seven species and one genus, but he takes occasion to point out that the most interesting results of his investigations are not so much novelty of characters in the new forms as the relationship between these South African types and others long known from remote parts of the globe. As an instance of this, it is mentioned that the description of the new Cape prawn, *Leontocaris paulsoni*, had only been published a few

months when the discovery of a second species of the same specialised genus was announced in deep water off the Irish coast. The paper is illustrated by fourteen plates.

FROM the morphological standpoint, the rodent mammals form an exceedingly compact and uniform group. From the occurrence of the phenomenon known as inversion it has been suggested, however, that, developmentally, the murine section (*Myomorpha*) should be associated with the Subungulata, while the squirrel and hare groups (*Sciuromorpha* and *Lagomorpha*), in which inversion is absent, should constitute a section or order apart. On the other hand, it has been asserted that inversion, although most developed in the *Myomorpha* and *Subungulata*, does also occur in the other two groups, and the suggestion has been made that all rodents agree in their early developmental stages, although divergence takes place later. To test this, Mr. A. Ochs, of Düsseldorf, has undertaken an investigation of the intra-uterine development of the hamster, the results of which are published in vol. lxxxix., part ii., of the *Zeitschrift für wissenschaftliche Zoologie*. The conclusions with regard to the classification of rodents are, however, deferred.

ONE of the latest additions to the admirable series of "Guide-books" issued by the natural history branch of the British Museum is devoted to the elephant group, and explains in precise and yet popular language the wonderful story of proboscidean evolution revealed by recent discoveries in Egypt. The publication of such a guide-book was rendered practically imperative owing to the fact that the collection of proboscidean remains in the museum is more extensive than any other in the world. So large and so nearly complete is the collection that it is possible for the visitor to see with his own eyes practically every link in the chain between the primitive Egyptian *Mœritherium*, on the one hand, and the highly specialised Indian elephant and mammoth on the other. In the case of several of the early forms, complete models of the skull have been recently installed in the geological department. The interest of the series would be greatly increased if a life-sized model of the head of the long-chinned, four-tusked mastodon (*Tetrabelodon angustidens*) were prepared and placed alongside the heads of modern elephants. The guide, which is admirably illustrated, has been prepared by Dr. C. W. Andrews, the great authority on the group.

A PAMPHLET on the preparation and use of anti-plague vaccine has been issued by the Bombay Bacteriological Laboratory. It gives details of the preparation of the vaccine, and full directions as to the mode of inoculation. Another pamphlet on the same subject, "The Cause and Prevention of the Spread of Plague in India," a lecture delivered by Captain Glen Liston, summarises in a complete and interesting manner our knowledge of the parts played by the rat and flea in the dissemination of plague.

THE first part has reached us of a new publication, *Parasitology*, a supplement to the *Journal of Hygiene*, edited by Prof. Nuttall, F.R.S., and Mr. A. E. Shipley, F.R.S. *Parasitology* will include papers dealing with the anatomy of mosquitoes, fleas, protozoa, and other parasites, which have only an indirect relation to hygiene and preventive medicine. The present part is devoted to a paper by Dr. Karl Jordan and the Hon. N. C. Rothschild on a revision of the non-combed, eyed Siphonaptera, a group of fleas to which that carrying plague belongs.

THE March number of the *Journal of the Royal Sanitary Institute* (xxix., No. 2) contains an important paper by Dr. Rideal on the relative hygienic values of gas and

electric lighting. The principal conclusions are that, owing to the better ventilation obtained by gas, the products of combustion are not present in the air in anything like the proportion that might be expected, the temperature and humidity in an occupied room being no greater than when the room is lighted with electric light; that carbonic acid has not the injurious effects formerly attributed to it; and that products—heat, carbonic acid, and moisture—are derived from the inmates more than from the illuminant.

THE work of improving the sugar-cane is still going on at Barbadoes, and the results obtained during the season 1905-7 are recorded in a publication recently issued by the Imperial Department of Agriculture for the West Indies. One of the new canes yielded as much as 2000 pounds of saccharose per acre more than was obtained from the ordinary White Transparent; it is obvious that differences of this kind are of prime importance to the sugar planter. Manurial experiments are also recorded; these are intended to find profitable combinations of manures. One result is rather interesting; nitrate of soda gave a larger yield of sugar than sulphate of ammonia, although the latter is commonly preferred in the West Indies.

IN the *Indian Forester* (February) prominence is given to an article by Prof. M. Henry on forests and rainfall. A theoretical discussion of the argument that the atmosphere contains more moisture in the neighbourhood of forests is clinched by the observation of an officer of engineers that a balloon will descend when passing over an extensive wooded area. It is also indicated how forests increase the rainfall of a locality and help to augment the supply of water from springs. A native apparatus for distilling camphor oil from the leaves of *Cinnamomum Tamala* is illustrated by Mr. B. Gopaliah.

THE sixth number of the Quarterly Journal of the Liverpool Institute of Commercial Research in the Tropics (January) has been received. Dr. E. Drabble contributes several short articles on West African oil seeds, dealing with *Carapa procera*, *Poga oleosa*, *Irvingia gabonensis*, the source of Dika butter, and *Scyphocephalum Kombo*; also a comparison of the barks of the red (*Rhizophora mangle*) and the white mangroves (*Laguncularia racemosa*) from the same region. Mr. R. Newstead furnishes the identifications and descriptions of several coccids infesting plants in Madagascar, among them being the gum-lac insect, *Gascardia madagascariensis*, that is allied to Cero-plastes, but is very different from Tachardia, the Indian lac insect. In connection with analyses of latex from *Ficus Voglii*, Dr. D. Spence directs attention to the high percentage of magnesium and chlorides contained, as compared with the latex of Hevea or Funtumia, in which phosphates are largely present, while chlorides are almost absent.

A SECOND paper dealing with the fern genus *Nephrodium* is communicated by Mr. S. Yamanouchi to the March number of the *Botanical Gazette*. It is concerned with spermatogenesis, oogenesis, and fertilisation in the genus as exemplified in the species *Nephrodium molle*. The author obtained a very complete set of stages in the development of the spermatozoid. Blepharoplasts, arising in the cytoplasm, were observed in the sperm mother cell. The important modification of this body occurs in the sperm cell when it flattens out above the nucleus, becomes band-shaped, and finally wedge-shaped, with the narrow end joined to the nucleus. Thus the anterior part of the sperm is formed from the blepharoplast. The development of the ovum is normal; in fertilisation the sperm

remains unchanged for a period after entering the egg nucleus, but eventually disintegrates with the formation of a reticular structure, and mixes with the egg nucleus.

BULLETIN No. 14 of the Edinburgh and East of Scotland College of Agriculture contains a detailed statement of the yield of milk and the percentage of fat therein obtained from a herd of twenty-seven cows. The fact that cows vary considerably in their milk yield is clearly brought out, and farmers are urged to keep systematic records of each cow's yield in order to improve the general standard by eliminating the poor ones.

No. 6 of the Memoirs of the Department of Agriculture in India deals with the movements of water in the soil. Perhaps no subject is of more importance to the agriculturist, or so little investigated in Great Britain and the British dependencies. Dr. Leather furnishes an interesting set of measurements which will prove of great value if they succeed in attracting some competent physicist to direct his attention to the numerous physical problems awaiting investigation in agricultural science.

THE February number of the *Agricultural Journal of the Cape of Good Hope* contains a report on the suitability of various South African fibre plants for paper-making. Four materials are discussed, matjesgoed fibre, palmiet fibre, papkui fibre, and bamboo; samples of the first three sent over to the South African Products Exhibition in London yielded pulp valued at 6l. or 7l. per ton, whilst bamboo pulp is valued at 9l. to 10l. In view of the abundance of fibre material in Cape Colony for which no use at present exists, the possibility of preparing pulp on the spot, and either exporting it or making it into paper, seems worthy of very careful consideration.

A NEW national forest, named the Verde, and consisting of 721,780 acres, has just been created, says the *Scientific American*, in Maricopa and Yavapai counties, Arizona. The forest lies on the west side of the Verde River, and constitutes a great part of its watershed. Most of the reserve is covered with brush that has no commercial value, but a small part has merchantable timber on it. The protection of the brush-grown area is just as important as that of heavily forested land, the scrub being the only thing that conserves the water and saves the watershed of the Verde River from erosion.

IN the *Mitteilungen* from German protectorates (vol. xxi., part i.), Dr. P. Heidke continues the discussion of meteorological observations made at Windhuk (South-West Africa) for the year ending June, 1906, commenced in the previous volume of this publication, dealing with the daily range of air-pressure and temperature and with their harmonic constituents. The effect of the continental climate is well shown in the small night minimum and evening maximum of pressure, as compared with the large morning maximum and afternoon minimum. The same number contains a valuable compilation, also by Dr. Heidke, of the monthly and yearly results, together with harmonic constituents, for twenty-five stations in the East African Protectorate, for the years 1903-4, deduced from tri-daily observations. References are also given to the periodicals in which the observations for previous years are published.

It is stated in *Engineering* of April 24 that H.M.S. *Tartar*, the turbine torpedo-boat destroyer, has satisfactorily undergone a very severe series of trials, and has been taken into commission. The *Tartar* is the fastest warship afloat, its speed on the official trials being 35.672 knots as a mean of six runs. During six hours' run the mean speed proved to be 35.363 knots, while the fastest run was

at the rate of more than 37 knots. The speed guaranteed by contract was 33 knots. The vessel is 270 feet long, the propelling machinery being Parsons turbines and six Thornycroft water-tube boilers.

THERE has been much controversy in recent years on the subject of that class of Palaeolithic stone implements which have been called *coliths*. The question has now been taken up in the April number of *Man* by Mr. Worthington Smith, who deals specially with discoveries in the North Herts and South Beds plateaux, and in particular with the contorted drift, which contains all the varieties of worked stones which were lying on its surface at the time of its deposition, including older and newer palaeoliths and their ever-accompanying *coliths*. The last class he thus attempts to define:—"At the present day all kinds of oddities in flint are passed off as '*coliths*'; one author says the examples must be bulbless; another describes well-formed bulbs. One says the secondary flaking is vertical; another that it is lateral. Sometimes a proof of authenticity is said to rest on the fact that the stones in question present no flaking at all, only rubbing. If museums are visited one sees ordinary palaeoliths masquerading as '*coliths*,' and rubbing shoulders with minor well-known Palaeolithic forms, iron-stained neoliths, surface flints, and late Victorian oddities of all sorts." In short, Mr. Smith concludes that there are no such things as "*coliths*" at all, nine out of ten of the thousands sent to him for examination being only natural flint fragments. "The tenth has been a minor and well-known Palaeolithic form, or, it may be, a bulbed, iron-stained, Victorian flake, knocked off by the hoof of a farm animal." None of those he has examined he believes to be as old as the Boulder Clay.

In a recently issued pamphlet ("*Plato or Protagoras?*") London: Simpkin, Marshall and Co., price 1s. net) Dr. F. C. S. Schiller propounds a novel and interesting view of the real significance of the speech attributed to Protagoras in Plato's dialogue, "*Theaetetus*." According to this view, the argument of the speech was not invented by Plato, but represents an attempt on his part to state fairly the actual case of an opponent whom he had not completely understood, and who had at the time of the composition of the dialogue passed beyond the reach of interrogation. Dr. Schiller seeks to justify his interpretation by maintaining that the criticisms which are directed by "*Socrates*" against the Sophist's arguments do not really refute them, and, in fact, prove merely that Plato had formed a very imperfect conception of their meaning and scope. Incidentally, Dr. Schiller takes occasion to claim that Protagoras was in all essential points an early exponent of his own doctrine of humanism, and that Plato's failure to refute him was prophetic of the superiority of the pragmatic philosophy over all forms of "intellectualism."

The *American Journal of Science* for April contains an article by Mr. H. M. Dadourian, of Yale, on the constituents of atmospheric radio-activity at New Haven. Mr. Dadourian suspended a negatively charged wire for three hours in a cavity in the ground, and another for four days in the air about 7 metres above the ground. On determining the rate of decay of the radio-activity of each wire, he found that 5 per cent. of the initial radio-activity of the first, and 20 per cent. to 30 per cent. of that of the second, was due to thorium and its products, the rest to radium and its products. From this he deduces that the amount of radium emanation present in the air of New Haven is about 40,000 times as great as the amount of thorium emanation.

THE Adamson lecture, founded in 1903 in memory of the late Prof. Robert Adamson, of Manchester, was delivered last term by Prof. J. J. Thomson, and has recently been published by the Manchester University Press. It deals with the relation between ether and matter brought to light by recent electrical investigations. Prof. Thomson points out that in electrical phenomena we are brought into contact with cases of interaction between bodies charged with electricity, in which the action of the first on the second is not equal and opposite to the reaction of the second on the first. In such cases we suppose that both bodies are connected with the ether around them, and that Newton's third law holds when we consider the ether and the two bodies as constituting the system under examination. From this point of view, the potential energy of an electrical system may be regarded as due to its connection with an invisible subsidiary system possessing kinetic energy equal in amount to the potential energy of the original system. This conception may be further extended to non-electrified bodies, and the ether thus comes to play an important part in ordinary dynamics.

PROF. ANDREW GRAY delivered an oration on Lord Kelvin at the University of Glasgow on Commemoration Day, April 22. The address dealt largely with the early work of the great master at Glasgow, when he was making the electrodynamic and electromagnetic theories more explicit, and testing them experimentally under conditions the antithesis of those which exist in the well-equipped laboratories of the present day. Prof. Gray mentions two views held by Lord Kelvin to which we may at the present time well devote special attention. He believed that the study of natural philosophy ought not to be excluded from the arts curriculum, and he was strongly opposed to the tendency which has been manifesting itself to separate the experimental from the mathematical side of physical work. With him the mathematical symbol was merely the servant of the idea, and mathematical methods had their place among the tools and instruments of research. The printed copy of the oration contains portraits of Lord Kelvin in 1846, 1868, and 1905 respectively, and a view of the outside of the natural philosophy rooms of the old college buildings.

PROF. P. ZEEMAN, in his second note on the magnetic resolution of spectral lines and magnetic force (*Konink. Akad. Wetens. Amsterdam, December 24, 1907*), gives some striking measurements of asymmetric separation, with excellent photographic reproductions illustrating the various stages. By means of the method of the non-uniform magnetic field, described in the first article in the above Proceedings for April, 1907, he finds it possible to study at a glance any series of phenomena dependent on the field intensity for a series of different intensities. The class of asymmetric separations herein considered has been predicted from theory by Voigt, and has also been considered by Lorentz. One of the most interesting cases is the yellow mercury line at λ 5791, the structure of which cannot be satisfactorily made out by the interferometer. The first-order spectrum of a Rowland concave grating of 6.5 metres radius, with 10,000 lines to the inch, has been employed for the investigation. It is seen that while the 5791 line is resolved asymmetrically, the neighbouring line, 5770, is resolved into a perfectly symmetrical triplet. Of this pair of lines a nine-fold enlargement of the original negative is given, showing most distinctly the above effect. The intensity of the magnetic fields employed varied from 14,800 to 29,220 Gaussian units. There are several points requiring further

investigation; the apparent inconstancy of the amount of asymmetry contrary to theory, also the apparent asymmetric intensities observed in the components of various lines. Careful measurements of the width of the lines show that the mean value is about 0.07 Ångström unit, and that the asymmetry amounts to about half this amount.

SIR WILLIAM RAMSAY contributes to the May number of *Cassell's Magazine* a popular article under the title "How Discoveries are made," in which he refers, among other matters, to the work of Priestley, Scheele, and Cavendish on air and combustion; Crookes, Lenard, and Röntgen on kathode rays; and Soddy and himself on radium emanation and its decomposition into helium, leading up to a short statement as to β rays and the corpuscular theory of electricity. The article provides general readers with a glimpse of scientific work, and is a welcome feature in a popular magazine.

THE Institute of Chemistry has published a second edition of the "List of Official Chemical Appointments." It has been compiled by direction of the council of the institute, and under the supervision of the proceedings committee, by Mr. Richard B. Pilcher, registrar and secretary of the institute. The scheme adopted in the first edition has been adhered to, the information has been corrected carefully, and numerous additions, including an index of names, have been made. The list is arranged in two main divisions; the first contains appointments in the British Isles, and the second in India, Canada, Australia, British colonies and protectorates, Egypt, and the Sudan provinces. The appointments dealt with include those under State departments, local authorities, and public institutions, in addition to teaching posts at universities, colleges, and schools. An appendix gives concise information as to societies for the advancement of chemical science and of professional chemical interests. The publication, the price of which is 2s. net, should prove of great service to all who are interested in the applications of chemistry to State purposes and in the teaching of the science at its various stages.

OUR ASTRONOMICAL COLUMN.

ASTRONOMICAL OCCURRENCES IN MAY:—

- May 1. 8h. 46m. to 12h. 28m. Transit of Jupiter's Sat. III. (Ganymede).
 3. 21h. 59m. Venus in conjunction with the Moon. Venus $4^{\circ} 15' N$.
 4. 8h. 48m. to 9h. 46m. Moon occults μ Geminorum (mag. 3.2).
 5. oh. 51m. Neptune in conjunction with the Moon. Neptune $1^{\circ} 20' S$.
 6. 22h. 41m. Jupiter in conjunction with the Moon. Jupiter $1^{\circ} 47' S$.
 7. 10h. 56m. Minimum of Algol (β Persei).
 15. Venus. Illuminated portion of disc = 0.388.
 " 8h. 42m. to 13h. 31m. Transit of Jupiter's Sat. IV. (Callisto).
 16. 11h. 15m. to 12h. 22m. Moon occults ψ Ophiuchi (mag. 4.6).
 19. 8h. 34m. Uranus in conjunction with the Moon. Uranus $0^{\circ} 35' N$.
 24. 23h. 47m. Saturn in conjunction with the Moon. Saturn $3^{\circ} 15' N$.
 29. Venus at maximum brilliancy.
 30. 9h. 25m. Minimum of Algol (β Persei).
 31. 13h. 52m. Mercury in conjunction with the Moon. Mercury $2^{\circ} 19' N$.

A NEW STAR-FINDER.—The "Metron" star-finder submitted to our examination by the maker, Mr. C. Baker, 244 High Holborn, is an ingeniously designed instrument

which will enable beginners in astronomy to become practically acquainted with the constellations and the brighter stars, and also with the more important problems usually placed under the heading "The Use of the Globes." It consists of a 4-inch celestial globe mounted on a tripod and stand so that it may be erected for any latitude. A date circle and a loose hour circle round the south pole enable the user to set the globe for any day and hour of the year. There is also a wire grip carrying a circle, with a pointer at its centre, and a pair of telescopic sights. Having set the globe for latitude, oriented it north and south by the fixed compass, and levelled the stand by means of the two bubbles set in it, the user sets the hour circle according to the directions, and places the pointer over the star, on the globe, which he wishes to locate and recognise; the real star may then be seen in the centre of the telescope field. In this way a number of constellations and important stars, of which the names are given on the globe, may be recognised. Conversely, knowing the date and the position of the star, the approximate time may be determined; special sights are supplied for work on the sun. To facilitate the reading of the globe and circles when working at night, a small electric lamp—and dry cell—is fitted to the stand.

The whole apparatus is nicely finished in nickel plate, and should prove useful in demonstrating problems in astronomy to beginners. For anything like accurate work, the apparatus in its present form and size is, we believe, on too small a scale; a very small error in the setting produces great confusion when magnified on the celestial vault, and the unaided beginner would probably find that his knowledge of the constellations was not considerably enlarged; when he began to be familiar with the instrument and the stars he would find in the combination a source of many hours of interesting work and problem-solving. Spare globes, covered with blank paper, may be obtained for the purpose of plotting the apparent paths of planets, &c.; on the present globe we notice one or two misspellings, e.g. Sygnus, Delphin, as the names of constellations. The price of the instrument, complete in box, is 2l. 12s. 6d.

SATURN'S RINGS.—In No. 4243 of the *Astronomische Nachrichten*, pp. 289 to 313 are devoted to records and discussions of observations of Saturn made by various observers during the end of 1907 and the beginning of the present year. Prof. Lowell and Mr. Lampland give the details of the Flagstaff observations, and the former discusses the appearance of the edge of the ring system and of the condensations remarked by Prof. Barnard, themselves, and other observers. When observing the shadow of the rings on the ball of the planet, all the Flagstaff observers noticed that it was traversed by a medial core the blackness of which was far more intense than that of the boundaries. This core was first observed on June 19, 1907, and was plainly visible on subsequent occasions; on November 5 the shadow generally was of a faint cherry-red tinge, and the black medial line was slightly undulatory, showing irregularities of outline. Drawing conclusions from the discussion of his results, Prof. Lowell finds that the rings approach more nearly to the body of the planet than hitherto measured, and that the middle and inner members of the ring systems are not flat rings, but tores; this would account for the condensations observed, and for the medial core of the shadow.

THE SYSTEMATIC MOTIONS OF THE STARS.—From the analytical study of the motions of 1100 stars having proper motions of between $20''$ to $80''$ per century, and distributed over both hemispheres, Prof. Dyson has obtained results which confirm those previously obtained by Kapteyn and Eddington, viz. that the stars are moving in two streams.

The positions found for the apices of the two streams as found by the different observers are shown below:—

	Stream I.	Stream II.
Kapteyn ...	R.A. 85° , Dec. -11°	R.A. 260° , Dec. -48°
Eddington ...	" 90° , " -19°	" 292° , " -58°
Dyson ...	" 94° , " -7°	" 240° , " -74°

The quick-moving stars considered in the latest discussion show the two distinct drifts very pronouncedly, particularly in the case of Stream II. For Stream I. the

three determinations agree within 7° of the position R.A. = 90° , dec. = -12° , and for Stream II. within 14° of the position R.A. = 263° , dec. = -60° (Proc. Roy. Soc. Edinburgh, vol. xxviii., part iii., No. 13, p. 231, February).

DETERMINATION OF THE ERRORS OF THE PARIS OBSERVATORY RÉSEAU.—In a paper communicated to the Paris Academy of Sciences, M. Jules Baillaud describes a novel method whereby he has determined the errors of the *réseaux* used in connection with the *Carte du Ciel* plates at the Paris Observatory. By this method the influences of variations of temperature and of deformation of the gelatin film during development are eliminated, and M. Baillaud finds that the errors attain the value 3μ , the variations between measures on several plates not exceeding 0.5μ . This is of the same order of size as the grain of the plate used, and it would probably be possible to reduce the apparent discordance by using plates of a finer grain (*Comptes rendus*, No. 12, March 23, p. 616).

THE HERSCHEL'S NEBULÆ.—No. 4, vol. ii., of the *Rivista di Astronomia* (Turin, April, p. 82) contains an article of especial interest and value by Madame Dorothea Isaac-Roberts, who discusses the nebulae discovered by the Herschels as photographed by the late Dr. Isaac Roberts. The author first gives a brief review of the history of nebulae observations from the time that Galileo discovered the first true nebula in 1610; then follows an explanation of the classification of nebulae made by Sir William Herschel, and of the code used by Sir John Herschel in his descriptions of nebulae. A brief description of the plates shown in the latter's memoir of 1833 is followed by a discussion of the groups of nebulous bodies as classified by Dr. Roberts. The paper concludes with a brief sketch of the lines which the author's discussion of Dr. Roberts's plates will follow, and is to be continued in the following number of the review.

HORIZON AND PRIME-VERTICAL CURVES FOR LATITUDES $+30^\circ$ TO $+60^\circ$.—In these columns for January 30 (NATURE, No. 1996, p. 302) we described briefly a useful sun and planet chart submitted for our inspection by Messrs. Carl Zeiss. The same firm has now sent us a transparent celluloid scale, devised by Herr H. H. Kritzing, which, when used in conjunction with the charts, enables one to see at a glance the relative positions of the local horizon and prime vertical for any place between latitudes 30° and 60° north. This allows the approximate sidereal time of rising and setting of the stars, and of their transit through the prime vertical, to be found at once, and with no trouble beyond that involved in superposing two sets of lines. Messrs. Zeiss will be pleased to send copies of this new scale on receiving applications.

EDUCATIONAL LEAKAGE.

THE success of any system of technical instruction or higher education depends ultimately upon the preparatory education of the students in our technical schools and other institutions of higher education. The results hitherto obtained from the work of colleges and technical schools in this country have been discounted seriously by the inadequacy in the nature and supply of the education for boys of school age. Mr. V. A. Mundella, in an address delivered last year to the Association of Teachers in Technical Institutions, directed attention to the subject, and also by means of curves illustrating recent statistics demonstrated the serious leakage of children at twelve and thirteen years of age, who afterwards receive no education whatever.

The accompanying diagram shows the number of children at stated ages, and the grade of education, if any, they are receiving. Mr. Mundella states that there are in England and Wales, between the ages of eleven and twelve years, 718,000 children, of whom 620,000 are in elementary schools, and at the outside 40,000 in public and private secondary schools. The curve T shows the total number of children at each year of age up to twenty-one years, and the curve A the total number of these children in

elementary schools. The form of A shows strikingly the rapid decrease in school attendance between the thirteenth and fifteenth years. The curve *f* exhibits the number of children surviving, at each year of age, who have attended an elementary school, and a comparison of this curve with those marked B, C, X, shows how little has been accomplished in the direction of continuing the education of the nation's children after the elementary school has been left. Curve B illustrates the total number of children in science and art classes, C in evening continuation schools, X in secondary schools, and U—a continuation of X—in universities and university colleges. The curve X is based upon statistics published in 1898, no later statistics being available. The curve D represents the number of surviving

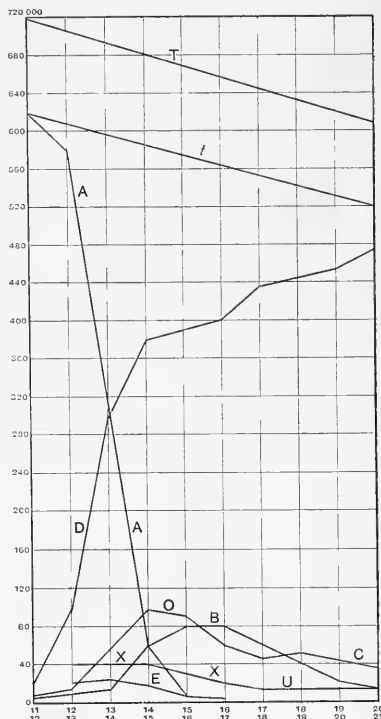

Diagram showing the number of young people in England and Wales between the ages of 11 and 21, and the number receiving education in schools and colleges of various types.

children who have attended elementary schools, but are receiving no further organised education, and E shows the total number of children at each age taking approved courses of instruction in State-aided secondary schools.

The facts embodied in this diagram demonstrate very clearly the need for strenuous national effort to insist upon children attending primary schools until they are fourteen years of age and abolish the present system of half-timers and other exemptions, to provide for continuation schools at which attendance shall be compulsory, and to establish secondary schools which are really schools of a high educational type. Schools in which 80 per cent. of the pupils leave at fifteen years of age or under are better described as higher elementary schools than as secondary schools, under which title they are at present classified.

THE SCIENTIFIC RESULTS OF THE VOYAGE
OF THE S.Y. "SCOTIA."¹

THE results of the meteorological, magnetical, and tidal observations made by the Scottish National Antarctic Expedition have now been published under the editorship of the leader, Dr. W. S. Bruce. This part of the work of the expedition was organised by Mr. R. C. Mossman.

The instrumental outfit was complete, well selected, and carefully standardised. Thus the barometers were compared with the Meteorological Office standard before and after the expedition, with the Argentine standard in January, 1904, with the Cape standard in May, 1904, and with the lighthouse barometer at the Falkland Islands.

Whilst at sea, and north of lat. 30° S., the meteorological observations were made four times a day. South of lat. 30° S. they were made hourly. From April to October, 1903, the *Scotia* was frozen up in Scotia Bay, Laurie Island, South Orkneys, and the observations were

and to use the observations taken on that set which was to the windward, the heating effect of the ship fires being sufficient to cause those instruments on the leeward side to read one or two degrees too high.

During the summer cruise of 1902-3 the Weddell Sea was filled with pack ice as far north as lat. 60° S., whilst in the next summer the *Scotia* reached Coats Land, lat. 72° S., without meeting any obstacle.

Comparison of observations made in the Weddell Sea with those made at Snow Hill, Graham's Land, shows that in February and March the pressure and temperature are higher than at Snow Hill. The cloud amount is also high, for during 81 per cent. of the time during which observations were made the sky was overcast, and only 3 per cent. of the time cloudless.

The observations at the South Orkneys were under the direction of the Scottish expedition only eleven months (April, 1903, to February, 1904), and were continued under the auspices of the Argentine Republic. By permission of



View of Copeland Observatory, Central Cairn, and Omond House, Scotia Bay. Reduced from a Report of the Scottish National Antarctic Expedition.

made on the ship. On November 1 the instruments were transferred to a stone hut which had been erected and called "Omond House." The observations were continued here while the ship went to Buenos Ayres to refit.

Besides the observations actually made by the staff of the expedition, the report also includes observations made at Cape Pembroke lighthouse. The *Scotia* took out to this lighthouse a number of instruments from the Meteorological Office, and the lighthouse keeper or his assistant made readings every four hours. The lighthouse was used by the *Scotia* as a base station.

In the discussion of the observations taken at sea, reference is made to the fact that it was necessary to have two sets of thermometers, one on each side of the ship,

the Argentine meteorological director, Mr. Mossman has been able to discuss observations taken during 1904, and records the mean temperature as 22°·7, the lowest reading being -26°, in June, 1903. The diurnal range of temperature varies from 1°·1 in autumn to 3°·2 in spring.

It was noted that, whereas on the eastern coast of Graham's Land the easterly winds are very conspicuous, the winds at Scotia Bay had only a very small easterly component.

As the expedition was not originally arranged with the intention of making magnetical observations, the only instruments taken were a portable magnetometer and a dip circle. There being no special non-magnetic area on the *Scotia*, no observations were made at sea.

A wooden hut erected not far from Omond House, and called the Copeland Observatory, was used to shelter these instruments. The observations were made under very adverse conditions. It was often found that the magneto-

¹ Scottish National Antarctic Expedition. Report on the Scientific Results of the Voyage of the S.Y. *Scotia* during the Years 1902, 1903, and 1904, under the leadership of W. S. Bruce. Vol. II., Physics. Pp. xvi+324. Edinburgh: Scottish Oceanographical Laboratory, 1907. Price 1s. 1s.

meter had become crusted with ice spicules, and it had to be thawed out before it could be used. Many other difficulties had to be encountered, and it is surprising that any successful observations were made; but Mr. Mossman, assisted by Mr. W. Martin, secured, besides other observations, hourly observations on twenty days.

The magnetic observations are discussed by Dr. Chree, F.R.S., who remarks that the results show how very carefully the observations were made. The observations extended over the period May, 1903, to February, 1904.

The following values are given:—declination, $5^{\circ} 31' 2''$ east; inclination, $54^{\circ} 30' 6''$ south; horizontal force, 0.25704; mean daily range of declination obtained from the hourly readings, 8'6".

While the *Scotia* was anchored and frozen in Scotia Bay observations of the tide were made by means of a very simple gauge. A long wire, fastened to the sea floor by a heavy weight, passed over a pulley, and was kept taut by a lighter weight at the other end. As the ship rose and fell with the tide this weight moved up and down a vertical scale, which was observed half-hourly.

The tides seem to be normal for a place in the Southern Ocean. The semi-diurnal tides are considerable, but the solar tide is unusually large compared with the lunar tide, the ratio being three-fifths, or 0.6, as compared with 0.465 of the equilibrium theory. The semi-diurnal tides are almost exactly "inverted," so that low water occurs very nearly when the moon is on the meridian.

THE METEORS OF HALLEY'S COMET.

IN view of the approaching return of Halley's comet, the Aquarid meteor shower of May ought to be awaited with special interest. We know comparatively little of this system, as it has been seldom observed. It is certain, however, that it is the richest of our May showers, and that its radiant point conforms very nearly both in date and place with the radiant and epoch of particles following the path of Halley's comet. This circumstance alone is significant, and the supposed connection of the comet and meteoric display will be sure to receive ample investigation during the next few years.

The Aquarids should be looked for after 11 a.m. in the mornings between the end of April and May 7, and they are directed from a region at about $337^{\circ}-3^{\circ}$, just below the equator. Lieut.-Colonel Tupman determined the radiant as about 10° west of the point assigned, and further observations are required to ascertain the exact place, and also the precise date of the maximum of the shower.

If really associated with Halley's comet, the meteors ought, in immediate ensuing years, greatly to increase in numbers, though we possess no historical records of rich showers having been observed in 1759 or 1835, when the comet previously returned to perihelion. But many meteoric phenomena have eluded recognition, and it is very possible that some returns of these Spring Aquarids may have escaped notice, as they are only visible just before sunrise, and were never specially looked for until after their discovery nearly forty years ago by Lieut.-Colonel Tupman. This stream, like the Perseids and Leonids and many other showers, is evidently one visible nearly every year, and forming a complete ellipse. It now remains for observations in immediately ensuing years to determine whether, like the Leonids and Andromedids of November, it develops unusual intensity near the time of return of the parent comet.

W. F. DENNING.

SOME UNSOLVED PROBLEMS IN METAL-MINING.¹

IN one sense every mine is an unsolved problem from the day the first pick is put into the ground until the mine is finally abandoned as exhausted, and even then it is not always certain that it really is worked out, and that sinking or driving another 10 feet might not give it a renewed lease of life. Unlike most engineering problems, which have generally to be solved before work is com-

¹ From the "James Forrest" Lecture, delivered at the Institution of Civil Engineers on April 27 by Prof. Henry Louis.

menced, a mining problem is never fully solved until all work upon it is finally concluded.

At the very outset, even before we are in a position to attack the different subdivisions of the subject, we are brought face to face with what may almost be described as one of the fundamental problems underlying the whole of metal-mining, and one the solution of which can never attain finality. The work of the metal-miner being limited to the extraction from the earth's crust of the ores of the various metals, whilst it is the business of the metallurgist to smelt these, so as to reduce therefrom the metals that they contain, and to fit the latter for their use in the arts, the question what constitutes an ore is one that the miner cannot answer for himself, and for the reply to which he is dependent entirely upon the development of metallurgical science for the time being. Not all metalliferous minerals are ores from the smelter's point of view. Take, for example, an ordinary brick clay, which is a complex hydrous silicate containing, say, 15 per cent. of aluminium and 5 per cent. of iron; it is true that we can extract both these metals from it by a series of complicated laboratory processes, but no means for doing this economically on a practical working scale have yet been discovered. Hence no one would dream of calling clay an ore of aluminium, and far less of iron. Nevertheless, it is not beyond the bounds of possibility that our modern metallurgists, or their younger and more progressive brethren, the electro-metallurgists, may within a few years devise some practicable process for extracting aluminium from clay, when clay would straightway become an ore of aluminium, though it is not one now; and if perchance it happened that comparatively pure oxide of iron were obtained as a by-product in the same process, the clay might even be reckoned as an ore of iron also. Until some such process shall be devised, clay is looked upon by the metal-miner as a non-metallic mineral, as so much worthless gangue or waste. The history of metal-mining has shown again and again that the waste rock of one generation is the valuable ore of another, as, for example, the zinc blende of the Alston district, which is now being recovered from the waste which the old miners had left behind as worthless in their excavations, or had thrown aside on their waste heaps, the value of the mineral having been recognised when a Belgian metallurgist discovered how to extract zinc from it.

The point may be further illustrated by a consideration of the world's supply of iron ore; iron, the most useful of all metals, is at the same time, next to aluminium, the most abundant, geologists calculating that 4.7 per cent. of the earth's crust consists of iron; if this estimate be correct, the very small portion of the earth's crust underlying the London Metropolitan area (fifteen miles' radius) down to the depth of only one mile would contain no less than 360,000 millions of tons of iron, none of which is in the form of a true iron ore. At the present day no one would call a mineral containing less than 25 per cent. of iron an iron ore, and unless it contains double that percentage it will not find a very ready or a very appreciative market amongst iron smelters.

As the result of various improvements in the last few decades, the whole trend of modern mining is towards the utilisation of large deposits of low-grade material, the increased scale of operations enabling economies to be effected that were impossible whilst small quantities alone were dealt with. One of the cardinal problems that will confront our successors will be how to work with profit minerals of lower grade than any that we have yet attacked, so as to enable the miner to include within his sphere of operations deposits too poor for us to deal with to-day.

The possibility of determining by some means the whereabouts of the hidden treasures of the earth has long been an object of the miner's desire, the methods for accomplishing which range from the mediæval adept with his divining rod, belief in which is not wholly extinct to-day, down to a series of modern attempts to use electric currents for the same purpose. Up to the present these attempts have been unsuccessful, in spite of the ambitious claims of some of their advocates.

In view of the fact that minerals differ so widely in their electric and magnetic properties, it is quite possible

to conceive that some method of detecting concealed mineral deposits by these means may be devised. Indeed, for one particular class of minerals such a method has long been in existence; in Scandinavia there are many deposits of magnetite, and many others of which magnetite forms a constituent, so that all such deposits distinctly affect a magnetic needle. The Swedish prospector has long used the so-called mining compass, which consists essentially of a small magnetic needle so suspended as to be able to move both horizontally and vertically. When this compass is brought over ground in which such deposits of magnetic mineral exist, the needle indicates their presence by its change of dip, so much so that it has been customary for years past in Sweden to buy and sell mineral properties by their "compass-drag," or their effect on the miners' compass.

When, by any means, some indication is obtained of the approximate position of a mineral deposit, it has to be more precisely located by boring. Boring is of but little value for tracing mineral veins, owing to their going down so nearly vertically and to their great irregularity, but it is often used to locate irregular masses of ore; for example, bore-holes have recently been employed successfully in Cumberland for proving deposits of red hæmatite in the Carboniferous limestone, even where this is overlain by Triassic rocks. Obviously bore-holes are most valuable when stratified deposits have to be tested, and everyone will remember the conspicuous success that attended their use in proving the permanence in depth of the auriferous banket beds of the Witwatersrand.

The deepest bore-hole put down up to the present is one at Paruschowitz, in Upper Silesia, which attained a depth of 6573 feet; it commenced at a diameter of 12.6 inches and finished at 2.7 inches, and it is easy to imagine the difficulties that attend the boring of so small a hole to the depth of $1\frac{1}{2}$ miles. The engineers in charge stated that they could not have reached this depth had not Mannesmann weldless steel tubes been available for the boring rods; I mention this fact as illustrating the dependence of mining upon the allied arts, for at first sight few would imagine that an improvement in special rolling-mill practice could increase our knowledge of the deeper portions of the earth's crust.

Bore-holes such as these are now always made by means of the well-known diamond drill, which brings up a core of the rocks passed through, and thus affords positive information respecting them. Unfortunately, the only kind of diamonds suitable for this purpose, the dark opaque stones, showing no distinct cleavage, known in the trade as "carbons," are very scarce and proportionately dear, so that diamond-drilling is now a very costly operation; I have, however, good grounds for saying that we are within measurable distance of seeing such "carbons," or at any rate "boot," produced artificially. For rocks of moderate hardness, these diamonds have of late years been replaced to some extent by shot made of specially hard chilled iron, but these are of little use in the harder rocks. One of our greatest needs at the present moment is a metal that shall be strong, tough, and very considerably harder than quartz; the production of such a material would conduce more to the technical advancement of several branches of mining than almost any other discovery that could be named.

Mineral deposits may be distinguished as superficial, shallow, or deep-seated in the earth's crust; the first of these require no opening up, properly speaking; the second can mostly be opened up by adit levels, whilst the third class can only be reached by means of shafts. The deepest shafts in the world are in the copper-mining district of Lake Superior, where there are at least two close upon 3000 feet in depth; with the exception of this district, of a few shafts in the Bendigo district of Victoria, a few at Johannesburg, and some in the Pzibram mines in Bohemia, it may be said that there are practically no shafts in metal-mines more than 3000 feet deep, so that the ability to reach considerably greater depths than have hitherto been attained in most mineral fields may be taken for granted. Indeed, so far as the actual sinking is concerned, there would probably be no serious difficulty in sinking a shaft 10,000 feet deep, provided that it could be known with certainty that a deposit of ore would be met with of sufficient value to recoup the outlay incurred in

such a sinking; in other words, the main problems connected with deep sinking are economic rather than technical.

For centuries the only property made use of to effect the separation of minerals was the difference in their densities; in 1858, however, an entirely new property was brought into play for the purpose, namely, the difference in their magnetic susceptibilities. This idea was due to a famous Italian engineer, Sella, whose name is well known in connection with the Mont Cenis tunnel. He was called upon to treat the iron ores of Traversella, in Piedmont, which consist of magnetite containing a certain proportion of copper pyrites (the mass carrying 2 per cent. to 4 per cent. of copper), which interfered with the use of the ore for iron smelting. Sella devised a machine carrying rotating electromagnets, by which the magnetic iron ore was separated from the non-magnetic copper ore, so that both could be utilised.

Other machines on similar principles were subsequently devised, and, naturally enough, they emanated from countries rich in deposits of magnetite, such as Scandinavia and some of the eastern States of America. Sweden especially took a prominent part in the development of the magnetic system of separation, and the Wenström machine, patented in 1884, which was one of the first practical machines brought out, is still largely used, as it is well adapted to the separation of lump ore. Other machines, more particularly designed for the treatment of finely crushed ore, were brought out in rapid succession, and to-day one of the main difficulties that beset the mining engineer lies in the selection of the most suitable machine for any given purpose out of the vast number with which the market is flooded. All these machines work either by means of a moving magnetic field, produced by travelling pole-pieces, passing through the mass of crushed ore, or by causing a stream of the ore to traverse a stationary field, these results being obtained either by travelling belts or revolving drums, or, as in the case of Edison's machine, by the deflection of a falling stream. It soon became apparent that, where very clean concentrates were required, the best results could only be obtained by applying magnetic separation to a pulp of mineral suspended in water, and wet magnetic separators were soon introduced, and are to-day preferred wherever possible; they avoid the necessity for artificial drying, which is, moreover, in the case of minerals that contain iron pyrites, apt to affect the magnetic susceptibility of this mineral sufficiently to interfere seriously with the success of the operation. Attempts have been made to devise magnetic separators without moving parts, by the use of polyphase rotating fields, but although the idea looks promising, no satisfactory machine on this principle has yet been constructed.

At first magnetic separation was only applied to the naturally magnetic ores, magnetite and magnetic pyrites; it was soon, however, extended to certain other minerals that can be rendered magnetic by heating, such as spathic iron ore, brown hæmatite, iron pyrites, &c. As early as 1875 a magnetic separator was used at Pzibram for separating roasted spathic ore from zinc blende, this forming an excellent example of the value of magnetic separation. The presence of spathic iron ore causes great difficulties in smelting zinc ores, as it forms a readily fusible silicate of iron which destroys the zinc retorts; at the same time, the densities of the two minerals are so nearly the same that separation by ordinary dressing is impossible. The application of magnetic separation has solved the difficulty, and has rendered available for the smelter numerous ferrous zinc ores that were previously useless. The process is receiving an extended application in America for treating argentiferous galena and zinc blende, finely divided, and intimately mixed with a large proportion of iron pyrites, in which the proportion of zinc is too high to admit of the ore being smelted direct, whilst the large amount of iron pyrites present interferes with ordinary wet dressing. This ore is crushed and then gently heated, which renders the pyrites magnetic, so that it can be removed by a magnetic separator; the dressing of the residual mixture of zinc and lead ores by the ordinary methods then offers no particular difficulties.

Whilst the ordinary methods of magnetic separation were thus extending the sphere of their applicability, another

form of magnetic separation was coming to the front. For a long time the method was confined to minerals that were naturally or artificially magnetic in the everyday acceptance of that word, that is to say, were capable of being attracted by an ordinary horse-shoe magnet. Faraday had discovered so far back as 1845 that numerous, not magnetic in this ordinary sense, were nevertheless affected by powerful magnetic fields, but it was not until 1896 that this principle was applied to the separation of minerals by J. P. Wetherill; he succeeded in separating a series of minerals, all very feebly magnetic, from the somewhat more feebly magnetic zinc oxide and other zinc ores of New Jersey by the use of very powerful magnetic fields, produced by means of electromagnets with wedge-shaped pole-pieces, and since his original invention this principle (the magnetic separation of non-magnetic material, as it is sometimes called) has found an extended application, one of the most recent being the magnetic concentration of specular hematite by the Edison deflection method, using pole-pieces of the Wetherill type. Such separations as that of wolfram from tinstone, of raw spathic ore from zinc blende, of garnets from silver ore, which are necessary before any rational metallurgical treatment of the ores is possible, but which offer insuperable difficulties to the ordinary methods of dressing, have been rendered possible by the adoption of the Wetherill principle, and I see no reason to doubt but that it will find still more extended application in the future. I may point out that no successful wet separator for feebly magnetic minerals has yet been devised; this is a problem presenting numerous difficulties, but probably quite capable of solution, and at the same time very well worth solving.

Magnetic separation, though so comparatively novel, has already been extensively applied, the largest installations being naturally those for the treatment of iron ores. At the present moment the output of high-grade magnetite concentrate, produced by this process, in Sweden cannot fall far short of half a million tons per annum, and in Norway active preparations are in progress for work on a much larger scale at Dunderland, Salangen, Ofoten, and Sydvaranger, from which a yearly output of fully two millions of tons of high-class iron concentrates is expected.

Attempts to utilise other properties of minerals for their separation may be said to belong wholly to the present century. Thus Messrs. Blake and Morscher in 1901, and Mr. Negreanu in 1902, have attempted to use electrostatic methods, depending upon the variations in the electrification of minerals due to their varying electric conductivities; the former of these two methods has been used with success for the dressing of blende in the United States.

Finally, the difference in surface tension has been employed in Elmore's oil separation process, in the various flotation processes, devised since the discovery of the principle by C. V. Potter in 1901, and applied to the very intractable zinc-lead ores of the Broken Hill district of New South Wales, and finally in the Elmore vacuum process. All these processes seem to depend upon the differential-adhesive force, with which water, oil, or gas cling to the surface of different minerals. These methods are still in their infancy, and the underlying principles cannot yet be said to be properly understood, but already they promise to be of great value in recovering valuable material from slimes that are not amenable to any other mode of treatment, particularly for treating those intimate mixtures of zinc blende and galena that have for so long defied the ingenuity of both miners and metallurgists. There are grounds for hoping that many of the problems that have hitherto baffled the ore-dresser may be solved by some application of these modern methods.

SCIENCE AND INDUSTRY.

A SERIES of articles has appeared in the *Revue scientifique* (May 18 and July 13, 1907; February 22, 1908) comparing the teaching of technical chemistry in France with the instruction given in the same subject in other countries. The last article is of special interest as presenting a French view of the relation subsisting between science and industry in our own country. After describing in detail the excellent organisation of scientific education in Germany, Belgium, and Switzerland, and

emphasising the closeness of the union existing in these countries between the manufacturer and the man of science, it is stated that the system of technical education adopted in England presents no feature worthy of commendation.

The English manufacturer fails to realise how much he may profit from the assistance of pure science:—"l'industriel anglais paraît ou veut ignorer le chimiste de carrière qui vient à lui avec un bagage scientifique; son but étant de produire 'beaucoup et à bon marché' il lui suffit quand il remarque un ouvrier plus intelligent et plus perfectible que ses camarades de l'envoyer aux écoles du soir, prendre un semblant d'instruction théorique et cela sur la seule partie de la chimie qui peut intéresser son métier." The many technical colleges under the control of municipal authorities in this country do not aim at producing highly trained "chemists" in the scientific sense of the word, but waste their resources in providing evening classes for workmen and artisans, and in imparting the rudiments of science to boys from the primary schools.

The university colleges, on the other hand, with the exception of the Central Technical College, provide only a training in pure chemistry. Until science and industry become more intimately united in this country it is predicted that the technical schools will go on producing merely good workmen and the universities men who are unable to investigate practical problems or apply discoveries made in the laboratory on an industrial scale.

It would appear that the chemist is a little appreciated in France as in our own country, and it is pertinently asked whether this is not due to his lack of "general culture" which prevents him from acquiring the broad ideas necessary for the initiation or development of important enterprises. The same question no doubt may be asked of the chemists in this country, but whatever be the answer there is no doubt that, for the proper development of our industry in the near future, a closer union between the industrialist and the chemist is vitally necessary.

UNIVERSITY AND EDUCATIONAL INTELLIGENCE.

CAMBRIDGE.—The board of managers of the Arnold Gerstenberg studentship gives notice that a studentship will be offered for competition in the Michaelmas term of 1909. The competition will be open to men and women who have obtained honours in part i. or part ii. of the natural sciences tripos, and whose first term of residence was not earlier than the Michaelmas term of 1903. The studentship, which will be of the annual value of nearly 90*l.*, will be tenable for two years.

The Linaere lecture will be delivered by Dr. W. Osler, F.R.S., on Wednesday, May 6, in the lecture-room of anatomy and physiology, New Museums. The subject of the lecture will be "Thomas Linaere, his Life and Works."

It is proposed to grant the use of the Senate House on May 15 for a meeting of the members of the University to be addressed by Mr. Haldane, Secretary of State for War, in the explanation of his scheme in connection with the training of officers for war.

Part i. of the natural sciences tripos will commence on Monday, May 25, and part ii. on Wednesday, May 27. The number of entries for the two parts is about two hundred and twenty.

GLASGOW.—Among the recipients of the honorary degree of Doctor of Laws on Commemoration Day, April 22, were several distinguished by their scientific attainments. In the afternoon a portrait of Prof. M'Kendrick was presented to the University, with the sum of 450*l.* for the equipment of a laboratory of experimental psychology in the new physiological buildings, in honour of Prof. M'Kendrick's thirty years' service to the University as professor of physiology. In presenting the representatives of science for the degrees, Prof. Glogau, dean of the faculty of law, made the following references to their work:—

MR. G. T. BELBY, F.R.S., chairman of the governors of the Glasgow and West of Scotland Technical College.—The present head of the Glasgow and West of Scotland Technical College, who is a Fellow of the Royal Society,

has done much for the advancement of chemical science and of its applications to industry. He was president of the Society of Chemical Industry in 1899, and of the chemical section of the British Association at its meeting in South Africa in 1905. He was also vice-president of the Institute of Chemistry from 1903 to 1906. He is the inventor of novel processes which have created or transformed important departments of scientific production; he has devoted himself to the improvement of technological training in relation to our native industries, and he has contributed many researches of value to the memoirs of learned societies at home and abroad. The Senate, in presenting Mr. Beilby for the degree of Doctor of Laws, recognise the value alike of his scientific work and of his services to an educational institution so closely connected with the University and with the City of Glasgow.

COLONEL DAVID BRUCE, C.B., F.R.S., Royal Army Medical Corps.—A graduate of Edinburgh University, Colonel Bruce has had a distinguished career in the Royal Army Medical Corps, and rendered eminent services to the nation in the Egyptian and South African campaigns. But his services have been not only to his country, but to humanity. To his discovery, at great personal risk, and by untiring labour, of the microbe which forms the inducing cause of Malta fever, and to the researches to which that discovery led, the naval and military population of Malta owe their present immunity from a disease which has been the bane of the island for centuries. Similar work in Africa has resulted in extending our knowledge of the causes which produce the dreaded tsetse-fly disease of South Africa, and the epidemic sleeping sickness of Uganda. Work of this kind, requiring all the courage of the soldier, all the patience and acumen of the man of science, renders him amply entitled to any honour which a university can bestow.

DR. J. J. DOBBIE, F.R.S., director of the Royal Scottish Museum.—In Dr. Dobbie the Senate proposes to honour a distinguished son of this University. Dr. Dobbie completed a successful career as a student by graduating with first-class honours in natural science, and obtaining the George A. Clark scholarship. After further studies in Germany and in the University of Edinburgh, he obtained the degree of Doctor of Science in that University. He acted as lecturer in mineralogy, and as assistant to the professor of chemistry in Glasgow, until his appointment as professor of chemistry in the University College of North Wales at Bangor. After holding that office for nineteen years, he was appointed to the important post he now holds—the directorship of the Royal Scottish Museum. During a life thus filled with important educational work, he has found time to make contributions of great value to scientific literature, in recognition of which the Royal Society of London has admitted him to the honour of its fellowship.

MR. ROBERT KIDSTON, F.R.S.—Mr. Kidston has devoted much time and study to an important department of the science of geology, and is recognised as one of the leading authorities on palaeophytology. A series of more than eighty papers, published under the auspices of the Royal Societies of London and Edinburgh, attest his knowledge of the Carboniferous flora. He has arranged and catalogued the collection of Palaeozoic plants in the British Museum. His mastery of the subject, and his generous readiness to expend his labour for the advancement of science, have been taken advantage of by other countries than his own. He has been engaged in a catalogue of the fossil plants in the Royal Museum at Brussels, and has received an invitation to undertake similar work at Stockholm. The fossil remains, now being discovered in the recently opened coalfields of Holland, are being submitted for his determination. In presenting Mr. Kidston for this degree, the Senate of the University of his native city wish to express their appreciation of his manifold services to geological and botanical science.

DR. J. C. M'VAIL, medical officer of health for the counties of Stirling and Dumbarton.—A graduate of the University of St. Andrews, and a former examiner in medical jurisprudence and public health in this University, Dr. M'Vail holds the highest position in that important department of modern civil administration—the care of public health. For eighteen years county medical officer

of health for Stirling and Dumbarton, he has been president of the Incorporated Society of Medical Officers of Health of Great Britain, of the Incorporated Sanitary Association of Great Britain, and of the Glasgow and West of Scotland Branch of the British Medical Association. In 1906 he delivered with acceptance the Lane lectures in Cooper Medical College, San Francisco, and the following year acted as medical investigator to the Royal Commission on the Poor Law. His published works, dealing with broad questions of State medicine and sanitary science, are recognised as authoritative in these important subjects.

THERE will be a reception at Bedford College for Women (University of London) on "Commemoration Day," Wednesday, May 6, after the presentation of graduates at the University of London.

AN article by Mr. J. A. Venn in the issue for the Lent term of the *Oxford and Cambridge Review* deals with the number of matriculations at Oxford and Cambridge, respectively, from 1544 to 1906. The article is accompanied by a graph, in which the number of matriculations—calculated on an average of five years about any given year from 1540 to 1907—and the years are plotted. The essay shows how the history of England has been reflected with clearness on university life, as evidenced by the varying numbers of students who came to pursue their studies at Oxford and Cambridge. The graph reveals two striking features:—first, both universities were in the first quarter of the seventeenth century as large as they were destined to be until 1850; secondly, the way in which the curves for the two universities keep repeating each other's movements at exactly the same dates, in most instances, and very frequently to exactly the same extent, showing that similar influences were affecting both universities throughout different centuries. Readers must be referred to Mr. Venn's article for detailed comparisons, but an example of the kind of interesting information which may be gleaned from the article may be given:—in 1630 one out of every 3600 of the male population of England and Wales proceeded to either Oxford or Cambridge, but in 1700 the figures were one in 5600. These figures continued to get steadily worse until 1801, when they read one in 11,400, but at the present day they stand at one in 9000.

THE Board of Education has issued (Cd. 4038) regulations for the preliminary education of elementary-school teachers in England, which will come into force from August 1 next. The new regulations contain various alterations, and among these, as being of special importance, may be mentioned that by which it will no longer be required that candidates for pupil teachership shall pass an examination test qualifying them for recognition by the Board as pupil teachers. A prefatory memorandum to the regulations points out that, since all pupil teachers must pass a leaving examination, which usually falls between the ages of seventeen and eighteen, it does not appear to the Board desirable, upon educational grounds, that they should also be called upon to pass an examination between the ages of fifteen and sixteen, except in so far as such examination may form part of the ordinary arrangements of the school at which they are being educated, or may be necessary in order to facilitate the proper selection of candidates. It is also satisfactory to find a recognition of the principle that the teacher should take a prominent part in any process of selection of suitable candidates. The Board hopes that, in view of the annually increasing proportion of candidates for pupil teachership who have received their preliminary education in secondary schools, it may be found possible, henceforward, for education authorities to base the selection and approval of candidates upon the advice of the teachers of the candidates rather than upon the results of an examination.

By the will of the late Dr. H. C. Sorby, F.R.S., several substantial gifts are made for scientific purposes. The Sheffield Art Gallery and Museum will receive Dr. Sorby's large series of animals and marine alga, mounted as lantern-slides, and forming a continuous series illustrating the natural history of Kent, Essex, and Suffolk. Among

other bequests to the University of Sheffield are:—(a) Such of his books not bequeathed to the Literary and Philosophical Society as the University shall select; (b) optical and scientific instruments and apparatus; (c) cabinets and cases of geological and mineralogical specimens and preparations not bequeathed to the citizens of Sheffield; (d) manuscript books and notes upon geological and other scientific subjects; (e) lantern-slides similar to those bequeathed to the citizens of Sheffield, and the whole of his large collection of lantern-slides illustrating many scientific and other subjects; (f) microscopic objects of rocks, minerals and metals, and other things of a like nature. A legacy of 6500*l.* is bequeathed to the University, and the University is desired to appropriate out of other funds 3500*l.*, the amount of a gift which Dr. Sorby made to the University College of Sheffield in 1903, making together 10,000*l.*, as an endowment for a professorship of geology or such other subject as the University may think more suitable. This legacy is charged upon the funds to be appropriated to answer certain annuities given by the will and payable as and when the annuities fall in. To the Royal Society of London is bequeathed the sum of 15,000*l.*, the income therefrom to be devoted to the establishment of a fellowship or professorship for the carrying on of original scientific research. The object is to promote the discovery of new facts rather than the teaching of what is known. It is suggested that when possible the research shall be carried out in one of the laboratories of the University of Sheffield. This condition may, however, be dispensed with when the nature of the investigation requires that the work should be done elsewhere. So long as in the opinion of the council of the Royal Society the University of Sheffield is not efficiently equipped in laboratories and appliances, then the income shall be administered in such manner as the said council shall think best for the promotion of original research. Other legacies are:—the Literary and Philosophical Society of Sheffield, 500*l.*, and the Geological Society of London, 1000*l.*

SOCIETIES AND ACADEMIES.

LONDON.

Royal Society, February 27.—"The Influence of Temperature on Phagocytosis." By J. C. G. **Ledingham**. Communicated by Dr. C. J. Martin, F.R.S.

(1) When serum, cocci, and leucocytes are mixed directly and incubated at different temperatures, the number of cocci taken up increases more or less regularly with the temperature. By this method it has been shown that the phagocytic intake at 18° C. is only about one-fourth to one-fifth of that at 37° C.

(2) This fall, at least within the temperature range 37° C. to 18° C., is due to the diminished rate of combination of the serum with the coccus as the temperature falls.

(3) When cocci which have previously been exposed to the action of serum, either at 37° C. or at 18° C., are put in contact with leucocytes, the intake is practically the same, whether the phagocytosis takes place at 37° C. or at 18° C. The number taken up, however, after combination at 18° C., and more especially at 7° C., falls very short of the number taken up after combination at 37° C.

(4) Experimental results, detailed above, lead one to assume that prolonged contact of a serum with cocci at a low temperature (18° C. or 7° C.) leads to a maximum absorption of opsonin by the cocci (corresponding to that temperature), so that the subsequent phagocytosis is identical whether it takes place at 37° C. or at 18° C.

(5) Provided that cocci loaded with opsonin up to a certain maximum are presented to the leucocyte, the phagocytic energy of the latter is independent of the temperature within a wide range.

(6) From the appearances on stained films, it would seem that sensitised micro-organisms exposed to the action of leucocytes at very low temperatures tend to congregate near the periphery of the leucocytes, although little or no phagocytosis may take place. Hence, within a suitable temperature range, it may be presumed that the inclusion

of sensitised micro-organisms by the leucocyte is a surface-tension effect taking place between the coccus and the protoplasmic wall, amoeboid energy playing only a subordinate part in the process.

MANCHESTER.

Literary and Philosophical Society, March 24.—Prof. H. B. Dixon, F.R.S., president, in the chair.—An annotated list of the alien plants of the Warrington district: G. A. **Dunlop**. One hundred and seventy-five species, comprising with others several of Papaver, Senecio, and Sisymbrium, were enumerated in the paper. Thirty of these are now extinct.—Field notes on the birds of the Ravenglass gully, 1906: C. **Oldham**. The author describes in his paper the habits, during the breeding season, of the black-headed gull, common, lesser, and Sandwich terns, as observed by him at Ravenglass, on the Cumberland coast. The term "gully" he applies to that portion of the sandhills which is occupied by colonies of these birds. He also mentions other species—such as the oyster-catcher and sheld-duck—which nest in or in the immediate vicinity of the "gully."

PARIS.

Academy of Sciences, April 21.—M. H. Becquerel in the chair.—An addition to the demonstration of the mechanism of monocular stereoscopy: A. **Chauveau**.—Concerning *Trypanosoma congolense*: A. **Laveran**. A goat, inoculated with *T. congolense* on November 15, 1906, was cured in July, 1907, from the infection produced by this trypanosome. Re-inoculated with the same organism on August 22, it was infected again, but the second infection was slight, and the animal was cured at the beginning of the following November. Two fresh inoculations, made December 20, 1907, and February 6, 1908, produced no re-infection; the goat had acquired immunity for *T. congolense*. Further inoculation of the same animal with *T. dimorphon*, made on April 1, 1908, produced a well-characterised infection, tending to prove that *T. congolense* constitutes a distinct species from *T. dimorphon*.—A new French observatory: Robert **Jonckheere**. This is the Hem Observatory, situated 8200 metres north-east of the fortifications of Lille. Astronomical observations will be commenced before the end of the year.—The influence of the silent discharge on the isolation resistance of insulators: F. **Nègre**. The resistance of the insulators studied was found to be constant up to a certain critical tension. The latter depends on the dimensions, form, and condition of the surface of the insulator, the resistance falling rapidly as soon as the silent discharge appears over the surface.—The flame spectra of iron: G. A. **Hem-salech** and C. **de Watteville**. The metal is obtained in a fine state of division by passing one of the gases supplying the burner over two electrodes of the metal, either an arc or sparks passing between the latter. The spectra obtained depended on the nature of the flame; thus with coal-gas and air in the region between λ 2250 and λ 5000 750 lines were obtained, with coal-gas and oxygen 250, and with hydrogen and oxygen 210.—The reducing power of the ferroporphosphates: P. **Pascal**. Clear solutions of ferroporphosphate of soda in water, together with a small amount of sodium pyrophosphate, reduce gold and silver, but not platinum salts. Salts of mercury and copper are also reduced, and there is a strong tendency to the production of highly coloured stable colloidal solutions of the metals.—Combustion without flame, and its application to lighting with incandescent mantles: Jean **Mounier**. The author holds that the temperature of the mantle is much higher than that of the flame surrounding it, and attributes this to the fact that each particle of oxide becomes the focus of an intense local combustion. The combustion by incandescence lowers considerably the inferior limit of inflammability of a gas mixture.—A demonstration of Gibb's phase rule: J. A. **Muller**.—Remarks on a wire-drawing machine of the seventeenth century: Ch. **Fremont**.—The progress of modern surgery judged by the statistics of operations on the knee (resections): M. **Lucas-Champagnière**. For this particular operation the mortality has been lowered from 36 per cent. or higher to less than 1 per cent. by the

application of the antiseptic methods of Lister. These results were obtained without the use of an aseptic operating room.—The structure of the trachean network of the excretory canals of the kidneys of *Machilis maritima*: L. Bruntz.—The Senonian and the Eocene of the north edge of the Moroccan Atlas: A. Brives.—A fan-shaped apparatus of *Cetorhinus* found in the fossil state in the Antwerp Pliocene: Maurice Leriche.—The direct measurement of the vertical component of terrestrial magnetism. Application to the exploration of the chain of Pays: B. Brunhes and P. David.

DIARY OF SOCIETIES.

THURSDAY, APRIL 30.

ROYAL SOCIETY, at 4.30.—On Scandium: Sir William Crookes, F.R.S.—Note on the Representation of the Earth's Surface by Means of Spherical Harmonics of the First Three Degrees: Prof. A. E. H. Love, F.R.S.—On the Hysteresis Loss and other Properties of Iron Alloys under very small Magnetic Forces: Prof. E. Wilson, V. H. Wilson, and G. F. O'Dell.—The Relation between the Crystalline Form and the Chemical Constitution of the Picryl Derivatives: G. Jerusalem and Prof. W. J. Pope, F.R.S.—The Condensation of Certain Organic Vapours: T. H. Laby.—A Photographic Determination of the Elements of the Orbits of Jupiter's Satellites: B. Cookson.

ROYAL INSTITUTION, at 3.—Mendelian Heredity: William Bateson, F.R.S. ROYAL SOCIETY OF ARTS, at 4.30.—Reminiscences of Indian Life: Lord Lambington, G.C.M.G., G.C.I.

MATHEMATICAL SOCIETY, at 5.30.—On a General Convergence Theorem, and the Theory of the Representation of a Function by Series of Normal Functions: Dr. E. W. Hobson.—On the Multiplication of Series: G. H. Hardy.—On q -Integration and Differential Equations: F. H. Jackson.—On the Upper and Lower Functions of a Sequence of Continuous Functions: Dr. W. H. Young.—(1) On Mersenne's Numbers; (2) On Quaterns with numerous Quartan Factors: Lt.-Col. A. Cunningham.—The Relation between the Convergence of Series and Integrals: T. J. A. Bromwich.—Parisms: H. Bateman.—The Influence of Viscosity on Wave Motion: W. J. Harrison.—On the Ordering of the Terms of Polars and Transvectants: I. Jerseris.

FRIDAY, MAY 1.

ROYAL INSTITUTION, at 9.—The Scientific Work of Lord Kelvin: Prof. Joseph Larmor, Sec.R.S. GEOLOGISTS' ASSOCIATION, at 8.—Structural Analogies between Alloys and Igneous Rocks: W. G. Fearnside.

SATURDAY, MAY 2.

ROYAL INSTITUTION, at 3.—Chile and the Chilians: G. F. Scott Elliot.

MONDAY, MAY 4.

ARISTOTELIAN SOCIETY, at 8.—The Methodological Postulates of Psychology: Dr. T. Percy Nunn.

SOCIETY OF CHEMICAL INDUSTRY, at 8.—The Manufacture of Sodium Nitrite: Dr. G. T. Morgan.—On some Simple and Mixed Esters of Cellulose. The Alkaline Decomposition of Nitro Derivatives of Cellulose and other Carbohydrates: Dr. W. Smith, junr.—The Mechanism of Filtration: E. Hatschek.—Metanil Yellow: its Use as a Selective Indicator: E. Jander.—The Conversion of Oleic Acid into Stearic Acid: Dr. J. Lewkowitsch.

INSTITUTE OF ACTUARIES, at 5.—The Select and Ultimate Method of Valuation: M. M. Dawson.

TUESDAY, MAY 5.

ROYAL INSTITUTION, at 3.—The Development of the Modern Turbine and its Application: Gerald Stoney.

ROYAL ANTHROPOLOGICAL INSTITUTE, at 8.15.—Report on the Hythe Crania: F. G. Parsons.

WEDNESDAY, MAY 6.

ROYAL SOCIETY OF ARTS, at 8.—The Gramophone, and the Mechanical Recording and Reproduction of Musical Sounds: Lovell N. Reddie. GEOLOGICAL SOCIETY, at 8.—Solution-Valleys in the Glyme Area (Oxfordshire): Rev. E. C. Spicer.—On the Stratigraphy and Structure of the Tarantath Mass (Tyrol): Dr. A. P. Young; with a Note on Two Cephalopods, collected by Dr. A. P. Young on the Tarantath Köpfe (Tyrol): G. C. Crick.

ENTOMOLOGICAL SOCIETY, at 8.

SOCIETY OF PUBLIC ANALYSTS, at 8.—The Examination of Oil of Turpentine and Turpentine Substitutes: J. H. Coste.—The Estimation of Potencyamide in Crude Commercial Products: Dr. H. G. Gilman.—Studies in Steam Distillation. Part III. The Fatty Acids: H. Droop Richmond.—A New Method for Milk Testing, and some Remarks on the Sydney Supply: W. M. Doherty.

THURSDAY, MAY 7.

ROYAL SOCIETY, at 4.—Election of Fellows.—At 4.30.—Helium and Radioactivity in Rare and Common Minerals: Hon. R. J. Strutt, F.R.S.—The Action of Resin and Allied Bodies on a Photographic Plate in the Dark: Dr. W. J. Russell, F.R.S.—A Tartarum Wave-detector, and its Application in Wireless Telegraphy: L. H. Walter.—Seleno-aluminium Bridges: Prof. G. M. Minchin, F.R.S.

ROYAL INSTITUTION, at 3.—Mendelian Heredity: William Bateson, F.R.S. CHEMICAL SOCIETY, at 8.30.—The Interaction of Diazonium Salts with Mono- and Di-hydroxy Phenols: and with Naphthols: K. I. P. Orton and R. W. Everett.—The Condensation of Benzoin with Methyl Alcohol: J. C. Irvine and D. McCulloch.—The Mutual Solubility of α -Methyl-piperidin and Water: O. Flaschner and B. MacEwen.—The Melting Points of the Anilides, β -Naphthylamides and α -Naphthylamides of the Normal Fatty Acids: P. W. Robertson.—The Refraction and Dis-

persion of Triazo-compounds: J. C. Phillip.—The Dissociation Constants of Triazoacetic and α -Triazopropionic Acids: J. C. Phillip.—The Absorption Spectrum of Camphor: W. N. Hartley.—The Viscosity of Solutions: C. E. Fawcitt.—The Action of Fused Potassium Hydroxide and of Hydrogen Peroxide on Cholesterol. Preliminary Note: R. H. Pickard and J. Yates.—The Fermentation of Mannose and Fructose by Yeast Juice. Preliminary Communication: A. Harden and W. J. Young.—The Volumetric Estimation of Silver: W. R. Lang and J. O. Woodhouse.—The Constituents of Olive Leaves: F. B. Power and F. Tutin.—The Constituents of Olive Bark: F. B. Power and F. Tutin.

LINEAR SOCIETY, at 8.—Colony-formation as a Factor in Organic Evolution: H. M. Bernard.—Antipatharia from the Voyage of H.M.S. *Sealark*: C. Forster-Cooper.—A List of the Fresh-water Fishes, Batrachians, and Reptiles obtained by Mr. J. Stanley Gardiner's Expedition to the Indian Ocean: G. A. Boulenger, F.R.S.—A Cinematographic Representation of the Movements of Peicapsus and other Invertebrate Animals: F. Martin Duncan.

CIVIL AND MECHANICAL ENGINEERS' SOCIETY, at 8.—Abbreviated Formulae for Structural Engineers: E. Fiander Etchells. INSTITUTION OF ELECTRICAL ENGINEERS, at 8.—The Manufacture of Electrical Condensers: G. F. Mansbridge.

FRIDAY, MAY 8.

ROYAL INSTITUTION, at 9.—Ice and its Natural History: J. Y. Buchanan, F.R.S.

ROYAL ASTRONOMICAL SOCIETY, at 5.

PHYSICAL SOCIETY, at 8.—A Modified Theory of Gravitation: Dr. C. V. Burton.—An Examination of the Formulae for the Grading of Gables: C. S. Whitehead.—Illustrations of Geometrical Optics: R. M. Archer.

SATURDAY, MAY 9.

ROYAL INSTITUTION, at 3.—Chile and the Chilians: G. F. Scott Elliot.

CONTENTS.

PAGE

Ancient Britain	601
Linear Algebra. By G. B. M.	603
Medical Physics. By J. H. R.	604
Our Book Shelf:—	
Hue: "Musée ostéologique; Étude de la Faune Quaternaire, Ostéométrie des Mammifères."—R. L. Mitton: "The Children's Book of Stars."—W. E. R. Noble: "Cradle Tales of Hinduisim."—Kawitz: "Lehrbuch der mikroskopischen Technik."—Prof. R. T. Hewlett	605
Letters to the Editor:—	
The Presence of Water Vapour in the Atmosphere of Mars.—Prof. Percival Lowell	606
The Condensation of Helium. (With Diagram.) Dr. Morris W. Travers, F.R.S.	606
The Radio-activity of Ordinary Metals: the Penetrating Radiation from the Earth.—Prof. J. C. McLennan	607
The Theory of Dispersion and Spectrum Series.—Norman R. Campbell	607
The Oligocheous Fauna of Lake Birket el Ourun and Lake Nyassa. By Frank E. Beddard, F.R.S.	608
The Forthcoming Dublin Meeting of the British Association. By E. E. F.	608
The Science Court of the Franco-British Exhibition. (With Plan.)	609
The Scientific Study of Starvation. By W. D. H.	610
Recent Progress of the Metric System	611
Notes	612
Our Astronomical Column:—	
Astronomical Occurrences in May	616
A New Star-Finder	616
Saturn's Rings	616
The Systematic Motions of the Stars	616
Determination of the Errors of the Paris Observatory Réseaux	617
The Herschels' Nebule	617
Horizontal and Prime-vertical Curves for Latitudes $+30^\circ$ to $+60^\circ$	617
Educational Leakage. (With Diagram.)	617
The Scientific Results of the Voyage of the S.Y. "Scotia." (Illustrated.)	618
The Meteors of Halley's Comet. By W. F. Denning	619
Some Unsolved Problems in Metal-Mining. By Prof. Henry Louis	619
Science and Industry	621
University and Educational Intelligence	621
Societies and Academies.	623
Diary of Societies	624

SUPPLEMENT TO "NATURE."

PHYSIOLOGICAL STIMULUS AND RESPONSE.

Comparative Electro-physiology. A Physico-physiological Study. By Prof. J. C. Bose. Pp. xliii + 760. (London : Longmans, Green and Co., 1907.) Price 15s. net.

IN sequence to his books on response in the living and non-living (1902) and plant response (1906), Prof. Chunder Bose has published a third volume on comparative electro-physiology. Prof. Bose has great ingenuity in device of experimental apparatus, fertility in initiating new lines of observation, and a clear style of setting forth his experimental results and theoretical deductions; nevertheless, we feel far from satisfied with his performance. He strives constantly to group every result he obtains under "some property of matter common and persistent in the living and non-living substance," and to explain by this assumed common underlying property the diverse phenomena of response which occur in metal wires, plant and animal tissues, on mechanical, thermal, or electrical excitation.

Prof. Bose says he started his investigations seven years ago in order to demonstrate this underlying unity, and we cannot help feeling that he has prejudged his phenomena, and, biassed by his philosophical conceptions, may select his experimental results and set before his reader those which confirm the main line of his argument. Using the photographic method of recording, and the galvanometer as the indicator of electrical response, he has published a series of figures, each one of which illustrates some argument in the text. No tables are given showing the number of experiments done or the failures and contrary results which occur in all lines of fresh investigation, and thus, while we feel grateful to Prof. Bose for suggesting fresh and fruitful lines of research, we must wait for confirmation by others of his many new and somewhat startling conclusions.

To instance some of these, Prof. Bose maintains that nerve, which is universally regarded as non-contractile, "is not only indisputably motile, but also that the investigation of its response by the mechanical method is capable of greater delicacy, and freedom from error, than that by the electrical." He demonstrates the contractility of nerve by means of the deflection of a spot of light reflected from a mirror attached to a light lever, thus obtaining magnification up to 100,000 times, but at the same time states that it can be demonstrated even by a light aluminium lever magnifying 50 times. This is contrary to the result of an English physiologist, who has, to our knowledge, tried a similar experiment. Here we have a definite assertion supported by many photographic curves and details of experiment, and one which, when tested by others, can enable us to arrive at a definite valuation of Prof. Bose's work. Such an independent valuation is required, as Prof. Bose and the English authorities on electrical physiology have been greatly at variance.

Prof. Bose claims that the fibro-vascular bundles of plants, which can be isolated in long lengths from the frond of a fern or petiole of cauliflower, act as vegetable nerves, the response being in every respect similar to animal nerve, and being affected similarly by ether, alcohol, ammonia, carbon dioxide, tetanus, &c. He regards the fibro-vascular system which forms the venation of leaves as a "vast catchment basin" for the reception of light stimuli and their transmission to the parts of the plant which are in the dark. By this nervous system, he says, the tone of the whole plant is maintained. In regard to Pflüger's law of the polar effects of currents, Prof. Bose demonstrates photographs showing the like effects on plant and animal structures, but finds that "above and below a certain range of electromotive intensity the polar effects of currents are precisely opposite to those enunciated by Pflüger." He endeavours to prove that the response of nerve to excitation consists of a positive and a negative variation, and that the tones of sensation, pleasure and pain depend on the ascendancy of one or other variation. He seems to recognise no deficiencies in the galvanometric method, and is unaware or neglectful of the work done with the capillary electrometer and of the diphasic variations obtained with this instrument by Prof. Gotch. The galvanometer is far too inert an instrument to demonstrate the true electrical response of nerve. Prof. Bose says that

"all the diverse phenomena of response may be summarised in the two following formulæ:—(1) Excitatory response takes place by contraction and galvanometric negativity. (2) Increase of internal energy induces the opposite effect of expansion and galvanometric positivity."

"The first of these effects is simply demonstrated by direct excitation of an excitable tissue. In order to demonstrate the second, stimulus is applied at a distance from the responding point. In consequence of sudden local contraction at the receptive area, a wave of increased hydrostatic tension is transmitted with great rapidity. Energy is thus conveyed hydraulically, and at the distant point the transmitted effect induces expansion and galvanometric positivity. This is followed by the more slowly transmitted wave of true excitation, which on its arrival gives rise to the normal response of contraction and galvanometric negativity."

All we can say in criticism of this statement is that while it may be true for plant tissue, there is not a shadow of fact in favour of it holding good for muscle, and we must remain unconvinced by the evidence adduced by the author in favour of its holding good for nerve, until his experiments on the expansion and contraction of nerve have obtained confirmation.

Prof. Bose finds that a metallic wire, the stem of a plant, and a nerve when suddenly submitted to torsion give the same electrical response, and in consequence is led to make the following statement:—

"By the conception of matter itself, on the other hand, as possessed of sensibility—that is to say of molecular responsiveness, we attain an immediate accession of insight into those physical interactions

which must furnish the terms of ultimate analysis . . . and are led to the discovery of the impressive continuity as existent between the responses of the most complex living and the simplest inorganic matter."

Sensibility is the power to feel, and is the function of the cerebral cortex of man, and also, we may assume justly from the similarity of the neuromuscular reactions, the function of the brain of the higher animals. That it is a function of the fish or frog brain we cannot affirm with any certainty. To ascribe it to a plant or wire is altogether unwarrantable.

A similar condition of molecular strain may be present in a wire, a plant stem, and a nerve fibre, and give the same electrical response, but this is not sensibility, and we even cannot conclude justly from the similarity of electrical response that the same mechanism is present.

Suppose we see a cloud of steam rising over the wall of a field. It may be from a traction engine, from a dung heap, or from a team of horses heated with ploughing. Observations on the direction of the current of steam, and on the effect of modifying agents upon it, will tell us nothing as to the nature of the chemical process which results in the manifestation of heat and the evaporation of water. Prof. Bose's philosophy seems almost capable of asserting that the similarity in direction of the steam current proves the sensibility, not only of the horses, but of all three structures.

Apart from these criticisms, there are in Prof. Bose's book a great many very interesting observations and ingenious methods of experimentation which will repay the reader's attention. In particular, his experiments on root pressure and the rise of sap; those by which he seeks to demonstrate that not only sensitive plants but all plants respond to excitation by variations in turgescence and electrical state; his comparison of the glandular structures of sundew and pitcher plants with animal glands; his demonstration of Dr. Waller's "blaze current" in a brominated lead plate and assertion that it cannot be regarded as a sign of life; his demonstration on the motile leaflets of *Biophytum* of the anodic and cathodic effects of the constant current, and the velocity of transmission of excitatory waves; his comparison of retentiveness of molecular change in metals with memory. In fact, the whole book abounds in interesting matter skillfully woven together, and would be recommended as of great value if it did not continually arouse our incredulity.

L. H.

THE STEREOSCOPE AND STEREOSCOPIC INSTRUMENTS.

Die binokularen Instrumente. By Moritz von Rohr. Pp. viii+223. (Berlin: Julius Springer, 1907.) Price 6 marks.

THE scientific staff of the Zeiss firm have of late years devoted much attention to the theory of binocular instruments, and to the development of method of measurement depending on stereoscopic

vision. The impetus given by the successful realisation of the prism field-glass has carried them on to a more exact examination of the conditions under which binocular vision can be employed for the accurate determination of relative position, which has led to the design of a series of new instruments for surveying and other purposes, of which the stereocomparator is the most widely known.

The thoroughness with which the problem has been considered is sufficiently illustrated by the present work of von Rohr, who has already in his previous writings dealt very completely with the theory of vision by means of binocular instruments. This previous work he has now supplemented with an examination into the historical evolution of stereoscopic instruments, systematically planned with the view of clearing the ground and avoiding loss of labour from the re-development of ideas already investigated by previous workers. The book is divided into three parts; the first gives in a few pages a concise statement of the theory; then follows the history, to which part i. is merely an introduction; and the volume concludes with a most useful systematic summary of the matter contained in part ii., assisted by what may be described as a logical guide arranged in the form of a genealogical table, showing the subdivisions of the subject and referring to the place of treatment. This third part, of course, includes a bibliography.

The history begins seriously with the work of Ch. Wheatstone, who is even better known as an electrician. Reference is indeed made to some previous writers and instruments, from the early binocular of Lippbergh, and the suggestive experiments of R. Smith. One notices some omissions here, but the book makes no pretence to be exhaustive; the object is only to trace out the development of correct principles of construction, and to indicate the most important workers and the advances due to them. From this aspect the book is almost too thorough and complete.

Much space is devoted to the famous controversy between Sir David Brewster and Wheatstone, again because of its value for the development of the theory. It is now generally recognised that Wheatstone had the much more correct grasp of the principles, and that the popularity of the Brewster type of prism stereoscope as against the Wheatstone mirror instrument was due to its superior handiness, which outweighed its optical deficiencies. It is interesting to note that Brewster records the sale of prism stereoscopes from the time of the Great Exhibition to 1856 as amounting to more than half a million; these for the most part on the improved mechanical design of Duboscq. One can still remember the wide interest aroused by this method of obtaining pictures in relief.

The interest, however, soon died down, only to be revived in comparatively recent years. The simple stereoscope was gradually improved, as well as the binocular microscope, and more especially the binocular field-glass. The advances of photography were accompanied by the invention of various methods of obtaining "stereograms." But public interest only revived with Abbe's introduction of the prism binocular. Since then Jena has been the centre for the spread of renewed enthusiasm for the subject, while

in this country few developments have been made. More attention has been given probably in England to the binocular microscope than to any other form of stereoscopic instrument. Quite recently Theodore Brown has experimented with a method of monocular bio-stereoscopic projection, which will doubtless one day be perfected and become widely known. But only his earlier work is mentioned by von Rohr, who does not carry his account beyond 1900. For the same reason, perhaps, we find no mention of the Forbes stereoscopic range-finder, or of the Aitchison prism binocular.

To those interested in the history of optics, and more especially to workers in stereoscopy, von Rohr's compilation will be of great value. For the general reader it is to be feared the technical manner in which the subject is presented throughout will prove somewhat of a stumbling block. This is, we think, a matter for regret.

AMERICAN PHYSICAL GEOGRAPHY.

Physiography. By Prof. R. D. Salisbury. Pp. xx + 770; xxvi plates, 707 figures. (London: J. Murray, 1907.) Price 21s. net.

THE large three-volume text-book of geology by Prof. Chamberlin and Salisbury has gained a firm place in this country owing to its full treatment of many questions, inadequately discussed in previous available English text-books. This companion volume on physical geography by Prof. Salisbury will accordingly be welcomed by British teachers of geology and geography. It is of great educational value owing to its wealth of lucid illustration and its clearness of exposition, while it will be indispensable as a reference work in geographical libraries owing to its detailed information regarding the physical geography of the United States.

The book is entitled "Physiography," but the term is used, as the author remarks in his introduction, as a synonym for physical geography, for it excludes many subjects which are included in physiography as that science was defined by Huxley and is accepted in the British Isles. The book consists in the main of a description of the structure of the earth's crust, of the working of the various agencies that attack it, and an account of the atmosphere and the oceans in so far as they affect the surface of the earth. Perhaps the most striking feature of the book is its illustrations, which are very numerous, well selected, and excellently reproduced. They are so clear that the author has been able to abridge his text, leaving his series of photographs to tell their own story. The excellence of the illustrations is probably in part secured by the use of heavy paper, so that the volume is of such weight as to hamper its use as a student's text-book.

As a book of reference its especial value is in its descriptions of the phenomena of physical geography taken from a country where the illustrations are unusually clear and suggestive; and it gives most useful summaries of such well-known geographical incidents as the San Francisco earthquake and of the fault which caused it; of the storm which destroyed Gal-

veston in 1900, and the tornado which devastated Louisville in 1896.

In the chapter on the "weather-maps," the author summarises various reasons for the failure of weather predictions, and he remarks that occasional mistakes are inevitable, and that one mistake is remembered longer than many correct forecasts. He claims that in many cases the American forecasts have been of immense economic value; for example, fifteen million dollars' worth of property were saved in 1897 by warnings of impending floods; on one occasion half a million dollars' worth of fruit about Jacksonville, in Florida, and during 1901, 3,400,000 dollars' worth of produce were saved by warnings of approaching cold; the forecasts also render it possible to avoid unnecessary risks, as when, in September, 1903, vessels valued at 585,000 dollars were detained in ports on the coast of Florida, and thus avoided a heavy storm.

In a work of so wide a scope there are naturally many points on which there is room for difference of opinion, but the author is cautious and fair in his treatment of all controverted questions. We are glad to find that he is emphatic in his statement that the term "Gulf Stream" is of doubtful propriety for anything beyond Newfoundland, and that the climate of north-western Europe would be much more temperate than that of corresponding latitudes of North America even if there were no Gulf Stream (pp. 544-5).

He holds that the only explanation of glacial periods which has not been discredited is that based on variations in the composition of the atmosphere. In his discussion of the question there is no criticism of Schloesing's view as to the control of the amount of atmospheric carbonic acid by the sea. The author is a firm adherent of the view of the ice erosion of fiords.

Each chapter is followed by a table of useful exercises, and by a list of references to literature. They are mainly from American sources, which is natural in a book designed for American students, but an English edition might have included more references to work easily available to British students; for instance, among the excellent illustrations and account of the eruption of Mt. Pelée and St. Vincent, there is no reference to the reports of Anderson and Flett. It may also be remarked that the Aconcagua ascent no longer holds the record, and that while it did, Zurbriggen was not the only man who had made it.

J. W. G.

POLYPERIODIC FUNCTIONS.

An Introduction to the Theory of Multiply-Periodic Functions. By Dr. H. F. Baker. Pp. xvi + 336. (Cambridge: University Press, 1907.) Price 12s. 6d. net.

THE saying that *Il n'y a que le premier pas qui coûte* certainly does not hold good of mathematics; and, oddly enough, it conspicuously fails in cases where it might be expected to justify itself. It is but a step from elliptic to hyperelliptic, from single to double Theta-functions; yet whereas Jacobi reduced all the essential theory of elliptic functions to a most elegant, and for some purposes a final,

shape, it is only now becoming possible to construct a corresponding theory for the hyperelliptic functions.

Towards this Dr. Baker, in the first part of his treatise, has made a really valuable contribution. The first chapter contains an extremely clear account of the hyperelliptic integrals, and in particular gives the standard ones in their explicit algebraic form. The corresponding Theta-functions are defined, and their properties investigated; the solution of Jacobi's inversion problem is given in an unusually clear form, and art. 10 contains an instructive discussion of the vanishing of a double Theta-function—perhaps one of the most troublesome points in the whole theory.

Chapter ii. contains the differential equations for the Sigma-functions which are afterwards used to find their expansions. By means of Aronhold's symbolical notation they are expressed in a compact invariance form; and the way in which they are obtained is an elementary one. At the same time, as the author would probably admit, the process is that of leading up to a known result, and not a heuristic one; this is not said by way of disparagement, because it often happens that tedious methods of discovery are properly replaced by others of a more artificial kind. Dr. Baker, in a note at the end, directs attention to the desirability of re-casting the demonstration so as to make it more strictly analogous to the method used for the elliptic Sigma-function.

Chapter iii. deals with the properties of Kummer's surface and Weddle's surface in connection with the properties of the hyperelliptic functions. Here the author's powers of dealing with algebraical analysis appear to great advantage. He has expressed the principal results in a form that is both explicit and elegant; and the English reader who has this book and Hudson's "Kummer's Surface" will be able to attack, if he likes, a very interesting and unusually definite field of research. Chapter v. is of a similar character, and contains, among other things, Mr. Bateman's proof of the differential equation of the asymptotic lines on Weddle's surface, and a geometrical interpretation of the addition theorem. Chapter iv. deals with the expansions of the Sigma-functions, and gives a great number of explicit terms; the invariance character of the coefficients should be specially noted.

The second part of the book, "on the reduction of the theory of multiply-periodic functions to the theory of algebraic functions," is of a much more recondite and difficult character. One of its main objects is to prove the theorem that the most general single-valued multiply-periodic meromorphic function is expressible by Theta-functions. The proof given partly depends upon Kronecker's theory of the definition of algebraic constructs (*Gebilde*) by means of systems of equations, partly upon the consideration of a set of "defective" integrals. Dr. Baker is admirably honest, and on p. 207 makes the remark:—"It seems certain that the values of k_{rs} can be taken so that the determinant $[c_{rs}]$ is not zero"; the temptation to make this a positive statement instead of a conjecture would have been considerable to many writers. Whether or not Dr. Baker's proof will stand minute

examination in all its parts remains to be seen; it is at any rate an original and very interesting discussion of an extremely difficult and important problem. It is not easy at the present time to foresee what will be the ultimate shape assumed by the general theory of Abelian functions. So far as mathematical rigour is concerned, as well as in its definiteness and attention to detail, the work of Weierstrass is preeminent, and its influence may be continually noted, and is frequently acknowledged in the present treatise. On the other hand, the more intuitive methods of Riemann and his followers are extremely illuminating and fruitful in suggestions and results; while as regards algebraic functions, the method of Dedekind and Weber is very hard to improve upon. One main difficulty, of course, is the increase in the number of independent variables in the associated Theta-functions; to get a "geometrical" field for the variables we must either plunge into unknown spaces or take new elements (*e.g.* straight lines) in our own.

Much light on the general theory and its difficulties is afforded by some special examples which Dr. Baker gives here and there, for instance, on pp. 255-72. In fact, an accumulation of such examples would greatly help beginners to grasp the arguments of the general theory.

In conclusion, attention may be directed to the great economy of space which the author obtains by abbreviated notation for matrices. The only drawback is that matrices are continually denoted by letters of the same type as those indicating quantities. Moreover, double Theta-functions are expressed in the form $\theta(u)$, which stands for $\theta(u_1, u_2)$; consequently, the beginner must be careful to realise the full meaning of the symbols, and he must at once make himself familiar with the elementary theory of matrices. Perhaps, in another edition, matrices might be indicated by letters of a special type.

G. B. M.

REINFORCED CONCRETE.

Principles of Reinforced Concrete Construction. By F. E. Turneaure and E. R. Maurer. Pp. viii + 317. (New York: John Wiley and Sons, 1907.)

THIS is the latest text-book on a branch of engineering construction which during the past ten years has developed from its first small beginnings to such an important position that not only is it essential for civil engineers and architects to be familiar with its various applications, but they should also have a sound knowledge of the principles which underlie the design of reinforced concrete structures. The authors have therefore practically divided the book into two sections, the first part dealing with the theory of the subject, the results of tests, and such questions as working stresses and economical proportions, while the second part is devoted to the application of reinforced concrete to building construction, arches, retaining walls, &c.

After discussing fully the properties of the two materials, concrete and steel, both when used independently and when used in combination, the authors proceed to obtain working formulæ for the

stresses in reinforced concrete beams and columns; in the case of beams of rectangular and T section, flexure formulæ are deduced, based on the assumption of linear variation of the compression of the concrete for working loads; and for rectangular beams on the assumption of a parabolic variation of this compression for ultimate loads, in both cases neglecting the tension in the concrete; examples are fully worked out to illustrate the use of these formulæ. A considerable amount of lengthy arithmetical work is necessary in using these formulæ, and a series of diagrams has been prepared, published on pp. 213-223, by means of which problems may be solved with rapidity and with a degree of accuracy quite sufficient for all practical purposes. These diagrams are at the end of chapter vi., in which the authors have collected together into a convenient form for reference all formulæ deduced in the earlier chapters of the book. Any engineer or architect who did not wish to check the accuracy of these formulæ or to become familiar with the principles upon which they are based, but merely desired to apply the results directly to some problem of design, would find everything he wanted in a compact form in the forty pages of this chapter.

Since T beams are often continuous over their supports, and since at such points there is a negative bending moment throwing the flange into tension and the lower part of the web into compression, a system of double reinforcement must be adopted in such cases, and this problem is fully worked out, as is also the problem of computing the stresses when the resultant of the external forces acting on the one side of the section of a beam is not parallel to that section. The remainder of chapter iii. is devoted to a discussion on the shearing stresses in reinforced beams, and to the strength of reinforced columns; as the authors point out, in ordinary construction the ratio of length to least width seldom exceeds 15, hence they have dealt with the problem simply as one of short columns.

In chapter iv., the results of a large number of tests of reinforced beams and columns are given, including many tests carried out by the authors themselves; not only are the actual numerical results of these tests of importance, as they afford the only safe test of the accuracy of the formulæ used in their design, but also much valuable information in regard to the design of such reinforced members may be gained from a study of the way in which the final collapse takes place; several plates are given, reproductions of photographs of the fractured beams, which show clearly how the disposition of the reinforcing bars in the beam influences the manner in which it gives way when the destructive load is reached.

In the next chapter the working stresses which can be permitted with this material are fully treated, and such constructive details as the use of steel of high elastic limit, the durability of the material, and its power of resisting the effect of fire. In the last three chapters a number of practical details in reinforced concrete work is given, and the problem of the determination of stresses in arches is dealt with in a very neat and compact fashion.

T. H. B.

THE EVOLUTION OF DRESS.

The Heritage of Dress, being Notes on the History and Evolution of Clothes. By W. M. Webb. Pp. xxvi + 393. (London: E. Grant Richards, 1907.) Price 15s. net.

THERE was certainly room for a scientific account of the evolution of dress. The present book, however, which professes to be "a popular contribution to the natural history of man," is hardly more than a collection of curious survivals in modern fashions, uniforms, the dress of the Court, the Church, the Bar, and other learned and official personages. The bibliography consists largely of articles in magazines and newspapers, and the author seems to have little acquaintance with the scientific literature of the subject, such as the frescoes of the Minoan Age unearthed by Mr. A. J. Evans; the contributions of Mr. H. Balfour, Mr. Skeat, Dr. Westermarck, and Dr. Haddon on the evolution of ornament; Prof. Ridgeway on the penannular brooch; Dr. J. G. Frazer's classical paper on mourning as a disguise to baffle the ghost. He appears not to have read even such popular works as those of the late Mr. Elworthy on the "Evil Eye" and "Horns of Honour."

But if Mr. Webb has not written a scientific treatise on the "Heritage of Dress," he has given us, within its limits, an interesting and suggestive book, provided with excellent drawings which really illustrate the many topics with which he attempts to deal, and with an index which, if not quite accurate, is still sufficiently comprehensive. His aim is to furnish a record of survivals, and perhaps in no department of modern life are these more numerous than in that of dress. It is a fact of much scientific importance in connection with the history of social development that so many details in modern costume which we are inclined to believe capricious or accidental, due to the inventive genius of the tailor or the milliner, are really traceable to primitive forms, and that the perpetual changes of fashions are the result of a process of evolution, advancing on conservative lines, in which the influence of early ideas is apparent.

This can be readily illustrated from the wealth of material supplied by Mr. Webb. Thus perhaps the earliest form of dress is the shawl or wrapper, the fringes of which in the modern examples date back to the most early kind of loom. From this are derived the jacket of the woman as well as the trousers of the man. It is more hazardous to trace the shape of the hat to that of the primitive hut; but the band on our silk hats and "bowlers," now purely ornamental, is almost certainly a relic of the fastening of the original cloth headdress.

The origin of liveries, which represent the costume of the wearers' masters in earlier times, is equally curious. When we come to uniforms, almost all their distinguishing features have a history as survivals. The red coat took its colour from that of the best coat in the days of Charles II., and it has thus naturally descended to the fox-hunter and golfer; the baton of the field-marshal is the box in which he used to carry the orders of his sovereign; the epaulettes of the Imperial Yeoman take us back to chain-mail; the

"prickers" of the hussar to the old flint-lock musket. Putties, which Mr. Webb traces back to Anglo-Saxon times, are proved by recent discoveries to be as old as the Mycenaean culture.

Much, of course, still remains mysterious. Why has a man's coat its buttons on the right, that of a woman on the left? Is the cockade descended from the chaperon headdress of the time of Richard II.? Whence come the buttons on the jacket of the page and on the trousers of the costermonger? Can it be, as Mr. Webb suggests, that grooms weave straw in the manes of horses because the horse was once thought to be a corn-spirit? Such matters require for their solution a wider range of induction and a more scientific study of the evidence than is provided by the present book, which raises, if it fails to solve, many other curious problems of the same kind.

MODERN VIEWS OF ELECTRICITY.

Modern Views of Electricity. By Sir Oliver Lodge, F.R.S. Third edition, revised. Pp. xvi+518. (London: Macmillan and Co., Ltd., 1907.) Price 6s.

WHEN Sir Oliver Lodge decided to issue a new edition of his well-known treatise, he set himself a very difficult task. The first edition was published in 1888, the second in 1892; he might well have thought that the development of the science during the past fifteen years had been so rapid that nothing short of complete re-writing could render the book deserving of its title. However, he has concluded that, since recent progress has amplified our views of electricity rather than altered them, the treatise has not lost its value; that it is still an expression of the truth, though it may be only a partial expression. Accordingly the general plan of the third edition is the same as that of the first; the changes that have been made consist of a few minor alterations and omissions, together with the addition of six appended lectures.

The earlier editions are so familiar that no detailed comment is necessary. Electrostatic, conductive, and magnetic processes are described and illustrated by a series of mechanical analogies, leading up to the representation of the electromagnetic ether as a medium made up of elastically connected gear wheels, separated in some regions by surfaces of slip. In the elaboration of these analogies the author is seen at his best; everything that he writes is extremely suggestive, though some students may be puzzled by the inconsistency between the different illustrations that are used in different parts of the book to represent the same action. We would direct special attention to the admirable treatment of the magnetic effect of materials with a permeability greater than unity.

However, we think that the author has underrated somewhat the change in even the simpler parts of the work, which has been necessitated by recent discoveries. It is true that these discoveries have affected our views of the electric properties of matter rather than the properties of electricity itself, but all electrical experiments involve the use of material bodies. Thus the discovery of the great difference between positive and negative electricity invalidates Sir Oliver Lodge's representation of the magnetic

field. He can no longer account for the negative result of Maxwell's attempt to find a finite angular momentum in a closed current circuit by the existence of two oppositely directed streams of positive and negative electricity; there must be a gyrostatic effect, though it is too small to be detected by any arrangement devised at present.

Again, our view of the effect of a material dielectric on electrostatic phenomena has changed completely. It is not believed now that the presence of sulphur alters the properties of the lines of force issuing from a neighbouring charged body; the effect of the sulphur on electrostatic actions should be represented in the same way as the effect of iron on magnetic actions. The view that all electric actions take place in the medium surrounding a charged body and not in the body itself has been modified; attention has been concentrated once more on the importance of the conception of a charge. It is misleading to speak of the dispersion of light as obscure and to suggest that it has no causal connection with selected absorption. The old view that a dielectric resists the passage of a current but may be "broken down" by a force sufficiently great suggests that a perfect vacuum devoid of all resisting matter should be a perfect conductor, and is utterly discordant with modern views. If the author did not see his way to re-write the book completely, we think that at least he should have added copious notes on these and many similar points to warn the student that the older statements must be revised in the light of later knowledge. As it stands, the book is of immense interest to those to whom modern conceptions are familiar, for it enables them to grasp at once the bearing of those conceptions on fundamental problems, but it would be dangerous in the early stages of reading.

We have detected one misprint on p. 224, l. 24: for "infinite" read "finite." We must also protest strongly against the use on p. 255 of the expression "centre of gravity of the ether" in place of "centre of mass." There is no evidence whatever that ether has a centre of gravity. N. R. C.

ENGLAND AN EXAMPLE FOR GERMANY.

Der naturwissenschaftliche Unterricht auf praktischer-heuristischer Grundlage. By Dr. F. Dannemann. Pp. xii+366. (Hanover and Leipzig: Hahnsche Buchhandlung, 1907.) Price 6 marks.

WE are accustomed in matters relating to school teaching to have German methods and results eulogised by contrast with our own, so that it is especially gratifying for once to find the tables turned. The author is a leading exponent of science teaching in his country, a schoolmaster of high repute in secondary schoolwork, and he has written this elaborate work frankly on the model of teaching that he witnessed at Harrow and other English secondary schools; and he has produced an account which in some respects is more thorough and comprehensive than anything we have in England. The only work to compare with it is the American book by Smith and Hall which appeared two years ago, and that deals only with chemistry and physics, while Dr. Danne-

mann covers biology as well. One half of the work is taken up with detailed recommendations for class teaching in branches of natural science, viz. physics, chemistry, mineralogy, geology, astronomy, and biology, then chapters are added on the equipment of laboratories, the preparation and use of text-books, the training of science teachers, the treatment of scientific ideas in the order of their historical development; then some half-dozen appendices give documents taken partly from the regulations of the Kultus Ministerium in Prussia and in other German States, side by side with resolutions adopted by associations of science teachers, in which no doubt Dr. Dannemann is a leading personality.

The adoption of the term "praktisch-heuristisch" is sufficiently significant of the author's position. He does not give the history of the name "heuristic," and only incidentally refers to Prof. Armstrong, but in all his work he is definitely on the side of those who insist that the centre of a course of science teaching shall be at the bench in the laboratory, and that demonstration and discussion in the class-room must be associated with and take their cue from this centre of activity. He has nothing but scorn for the "Kreidephysik" which is still too commonly found in German schools, where the teacher with his chalk and blackboard demonstrates the truths of natural philosophy. It is very interesting to witness, from the pages of this work, how very reluctant German authorities are to adopt these reforms, and no doubt a strenuous advocate of English methods has not always a happy time among his countrymen. Indeed, the case is curiously paralleled by what is happening in England as regards modern language teaching. The "reformers" here look chiefly to Victor and others in Germany for inspiration, and turn to many examples in German schools to show how a foreign language can be acquired. Dr. Dannemann tells his countrymen to look to the practical English teacher and to abandon their reliance on the parrot-like learning of scientific text-books.

Although much of the ground covered by these chapters will be familiar to the English teacher of science, there are portions which are novel, especially in the plans by which the author hopes to give a secondary schoolboy some grasp of the entire field of natural science before leaving school; and the sketch of science teaching from the genetic standpoint is also well worthy of careful perusal.

The chapter on the training of science teachers seems to us the weakest part of the book. It is difficult to see how university men can be kept for a year doing the very elementary work which Dr. Dannemann proposes for them; a man ought to have learned, during his university career in laboratories, to be able to secure himself and his scholars against accidents. But it is a little difficult to realise fully the conditions of German schools in these respects. We are sure from the quality of this and other writings by the author that any "Kandidat" who was sent to learn the business of a science teacher from him would gain a thorough understanding both of principles and practice.

WIRELESS TELEGRAPHY AND TELEPHONY.

Jahrbuch der drahtlosen Telegraphie und Telephonie. Band i., Heft i. Edited by Dr. G. Eichorn. (Leipzig: S. Hirzel, 1907.) Preis für den Band, 20 marks. *Wireless Telephony in Theory and Practice.* By E. Ruhmcr. Translated by J. Erskine-Murray. Pp. xv+224. (London: Crosby Lockwood and Son, 1908.) Price 10s. 6d. net.

THE publication of the first number of a German year-book of wireless telegraphy and telephony affords an indication of the growing importance of this branch of electrotechnics. The volume before us is more of the character of an ordinary scientific magazine than of a year-book, since there is not really much attempt to summarise the progress during the past year, which, we take it, is peculiarly the function of a year-book. This objection apart, the publication deserves praise on account of the merit of the articles which it contains. Of these the most important are one by Prof. F. Braun on directed wireless telegraphy, one by Dr. Simon on the production of undamped waves, and one by Prof. Fleming on some of the most recent developments.

Dr. Simon's article will be read with special interest at the present time on account of the experimental work which is being carried on in all countries for the development of wireless telephony. In addition to these and some minor papers, there is a valuable bibliography.

The development of wireless telegraphy during the twenty years which have passed since the discoveries of Hertz has presented some peculiar features. Grown out of a discovery which, theoretically regarded, was of a sensational nature, wireless telegraphy has always seemed to have a tendency to sensational rather than solid progress. Except in so far as its military and naval value is concerned, the world at large cannot be said to have derived as yet any very great advantage from its development, and we doubt whether financial success, the touchstone of utility, has as yet rewarded any of the companies which have been pioneering the various systems. On the other hand, sensational performances, in which the hearts of all wireless workers appear to rejoice, have been frequent. The Marconi Company's first attempts to establish Transatlantic communication, the signal failure of their first commercial system of Transatlantic wireless telegraphy, and the apparent failure, so far, of their more recent attempt, will be fresh in the minds of all. As we have before pointed out in these columns, it would appear that the enormous efforts and expenditure which have been lavished on the development of long-distance signalling might have been much more usefully spent on the development of less ambitious but more solidly useful schemes.

More recently the attention to the production of undamped oscillations on the principle of the Duddell musical arc (as in the Poulsen system) has stimulated research on the wireless transmission of speech, and considerable success has attended the experiments. In Germany successful transmission across ten miles of land (right across Berlin) has been attained, and in America, in addition to the equipment of the torpedo-

boats of the Pacific fleet with wireless telephone apparatus on the De Forest system, one may note that stations have been working successfully on the Fessenden system over a distance of 200 miles (more than half over land).

A very full descriptive account of the experimental work which has been carried out on wireless telephony is to be found in Prof. Ruhmer's book. The volume is not confined to telephony by means of Hertzian waves, the particular branch which now occupies the most important and the most promising position. In fact, nearly one-third of the volume is devoted to wireless telephony by means of light, in which a speaking arc is utilised as transmitter and a sensitive selenium cell as receiver. This method, which owes much of its development to Prof. Ruhmer, has attained considerable success, fair distances having been bridged over both water and land. The volume is profusely illustrated by both photographs and drawings, and should prove a useful reference work for those directly or indirectly interested in the subject.

There can be no question that the successful solution of the problem of wireless telephony will mark a very considerable advance in the art of wireless communication. It is true that the difficulties of interference and lack of secrecy have to be met with telephony as with telegraphy, but there are, at any rate, the same compensating advantages which are to be found in ordinary telephony over telegraphy. It is to be remarked also that efforts to establish long-distance wireless telephony, across the Atlantic, for example, are not open to the same objection as applies to the attempts to establish Transatlantic wireless telegraphy, since in this case the field is not already occupied by cables performing the same service more efficiently.

M. S.

THE TABERNACLE AND THE TEMPLE.

The Tabernacle: its History and Structure. By the Rev. W. Shaw Caldecott. Pp. xxii+236. Second Edition. (London: Religious Tract Society, 1906.) Price 5s.

Solomon's Temple: its History and Structure. By the Rev. W. Shaw Caldecott. Pp. xiii+358. (London: Religious Tract Society, 1907.) Price 6s.

THE interest which Anglo-American Protestantism has always taken in the præ-Christian Biblical books, and in the land of Canaan, in which the events of ancient Israelitish history, traditionally described in them, took place, has again been exemplified in yet another addition to the long list of pious speculations as to the appearance of the Israelitish Tabernacle and of the Temple of Yahweh at Jerusalem. Mr. Caldecott is an enthusiast, like his forerunners, for none but an enthusiast would be bold enough to explain the meaning of doubtful cuneiform signs to cuneiform scholars, or to invite prefaces from a master of cuneiform science, Prof. Sayce, in which the ingenuous author of the book is publicly told that, however nice and interesting his discussion of the Tabernacle and the Temple may be, his cuneiform cannot be accepted.

Mr. Caldecott's *naïveté* in thus rushing in where those who know the root of the matter fear to tread, necessarily vitiates the credibility of the remainder of his speculations in the mind of the scientific reader.

Nevertheless, Mr. Caldecott is more critical than most of his predecessors, which is an encouraging symptom. His sketch of the history of the Jewish Kingdom is very readable, and, though conservative, contains little at which a moderate "higher critic" might cavil, though no doubt a Jerahmeelite might consider it a sufficiently benighted performance. The views of the Jerahmeelites do not, however, any longer count among scientific archæologists in England, although the Germans, swayed by their quaint national delusion that no really valuable work in archæology or Biblical criticism can possibly be done by anybody but Germans (or non-Germans taught to perform the scientific *Parademarsch* by German drill-instructors), no doubt still believe in the wild "North-Arabian" theories of Winckler in which Cheyne found support for the Jerahmeel-cryptogram.

We are glad that Mr. Caldecott has not adopted the legend of the "second Musri," and that for him Esarhaddon's "Sib'e," the *Tartannu* of Pir'u King of Musri," is, as he is to every sane critic, "So (Seve) the general of Pharaoh King of Egypt," *i.e.* the King Shabak understood as an officer of the Ethiopian king, probably Kashta, who ruled in Upper Egypt. But we think that Mr. Caldecott, in his note on Sib'e ("Temple," p. 139), should have referred to Winckler's Musri-theory, and given his reasons for not accepting it. This would have been the scientific way of doing things. As it is, he lays himself open to the suspicion of not having known anything about an important theory, very germane to his subject, which archæologists and "higher critics" have been debating for years. And this possibility again makes one doubt the real value of this sort of work, despite the kind words of encouragement bestowed by Prof. Sayce upon the present author in respect of everything but his cuneiform. Whether, as he thinks, Mr. Caldecott's speculations will excite new interest in excavations in Palestine is doubtful; unluckily, these excavations have not always produced such "pat" results as seem generally to be expected from them. Those of the Austrians at Taanach seem to be the most interesting hitherto.

The identification of the modern Rāmet el-Khalīl with the ancient Ramah near Jerusalem, where the Tabernacle was set up, is, as Mr. Caldecott points out, due to the late Edward Robinson, who proposed it in 1838. The latter calls it quite correctly "er-Rameh"; Mr. Caldecott should be careful not to go on calling it, as he continually does, "Ramet" when he does not add the suffix "el-Khalīl"; the name of the place is Rāmech or Rāma (usually with the definite article prefixed), which becomes "Rāmet" in the construct state, as "Rāmet el-Khalīl."

In conclusion, we would advise our author, before he publishes new editions of his books, to consult the articles "Tabernacle" and "Temple," by Dr. Benzinger, in the "Encyclopædia Biblica"; they may give him some novel information on certain points.







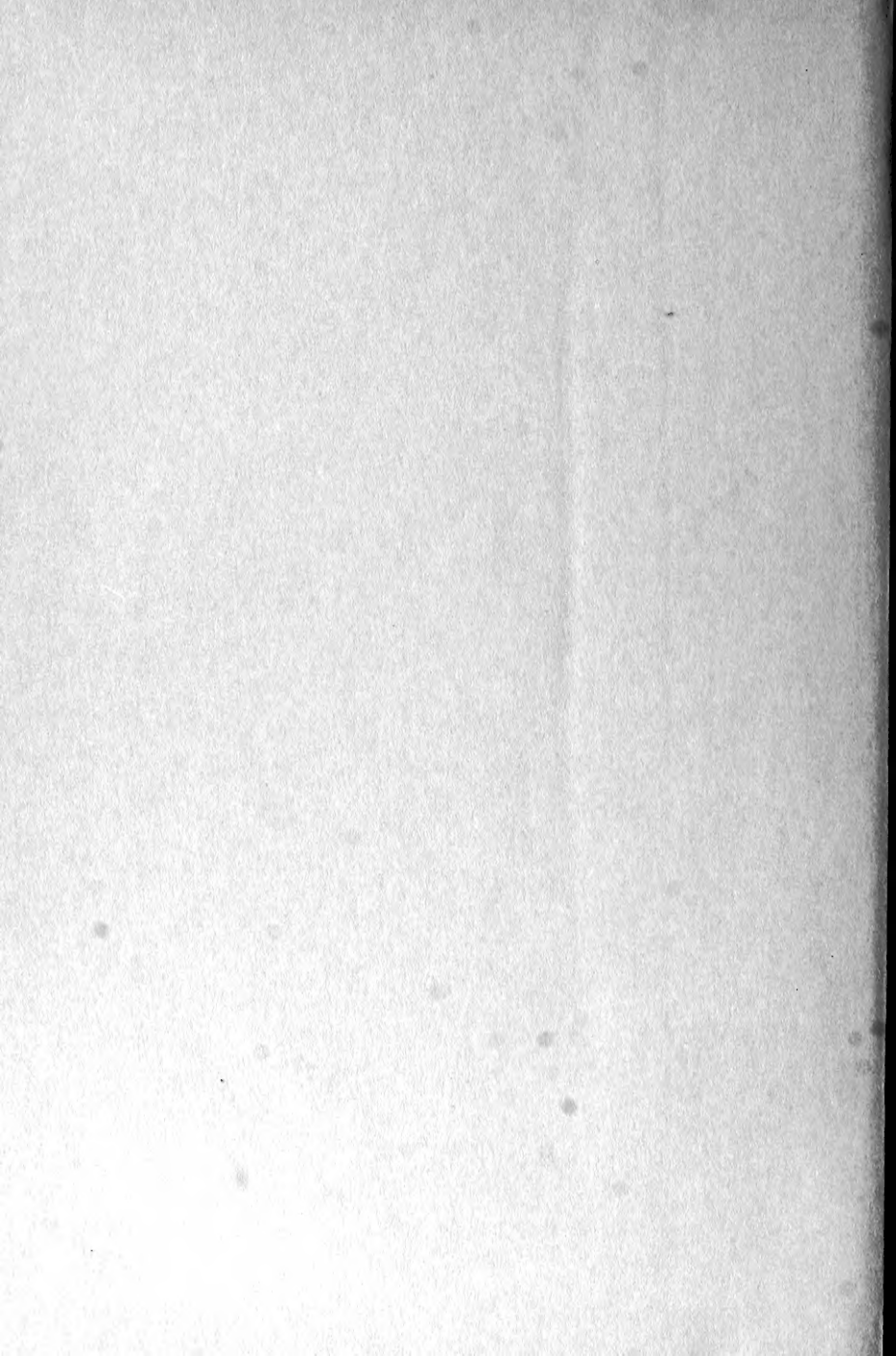



SMITHSONIAN INSTITUTION LIBRARIES



3 9088 01359 6739