

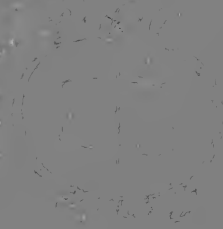

Handwritten text, likely bleed-through from the reverse side of the page. The text is arranged in several lines and is mostly illegible due to fading and the texture of the paper. Some faint words like "THE" and "AND" are visible.







Digitized by the Internet Archive
in 2007 with funding from
Microsoft Corporation

NAVIES OF THE WORLD;

GIVING CONCISE DESCRIPTIONS OF THE

PLANS, ARMAMENT AND ARMOR

OF THE

NAVAL VESSELS

OF

TWENTY OF THE PRINCIPAL NATIONS.

TOGETHER WITH THE

*LATEST DEVELOPMENTS IN ORDNANCE, TORPEDOES,
AND NAVAL ARCHITECTURE,*

AND A CONCISE SUMMARY OF THE

PRINCIPAL NAVAL BATTLES OF THE LAST TWENTY YEARS,
1860-1880.

BY

LIEUT. EDWARD W. VERY, U.S.N.

NEW YORK:
JOHN WILEY & SONS,
15 ASTOR PLACE.

1880.

VA 40
V 4

COPYRIGHTED, 1880, BY
JOHN WILEY & SON.

70 WIL
ANNOUNCED

PREFACE

DURING the past twenty years the changes in the "matériel" of which fleets are composed have been so rapid and universal that it has been impossible at any time to form a true estimate of the strength of the navy of any maritime power that would be of any value beyond a very limited time. With displacements advancing from 5000 to 13,000 tons; weight and power of ordnance developing beyond the most exaggerated conceptions of twenty years ago; torpedo warfare springing into existence and developing as a new and special arm; modifications in engines and boilers by which speed has been developed from 12 to 18 knots, and steaming capacity from 2500 to 6000 miles; the revolution of naval tactics, and the entire change in the conditions of naval warfare brought about by the development of armor defence and the ram attack, —it is only through paying the closest attention and under exceptionally favorable circumstances that naval officers have been able to comprehend the magnitude of the general result.

It is only within the past two years that the craze for naval development has subsided to a slow and steady advance, and the present time has been seized upon as one favorable for measuring the actual strength and resources of the navies of the world.

In preparing this work the author has simply aimed at representing in as detailed a manner as possible all the elements which go to make up the active naval strength, leaving to those who in their search for information may have recourse to the data herein presented to estimate the

values of these elements as they are developed and combined in different navies, and to judge for themselves of the true value of the results obtained.

In collecting this data the greatest care has been taken to only give such as is entirely authentic. For the most part it has come from official sources, and, wherever it has been necessary to make comparisons or to give opinions, the writer has in no case given his own independent ideas on the subject. The principal authorities, aside from official records, whose works have been consulted are : Reed, White, Dislere, Marchal, and De St. Bon, on Naval Architecture ; Owens, Mayevski, Sebert, Müller, and Cooke, on Ordnance ; Schleeman and Stotherd, on Torpedoes ; and Von Billerbeck, on the iron-clads of the first decade.

EDWARD W. VERY,
Lieutenant U. S. Navy.

WASHINGTON, June, 1880.

CONTENTS.

PART I.—FLEETS.....	PAGE 1
---------------------	-----------

Argentine Confederation, Austria, Brazil, Chili, China, Denmark, England (Armored Fleet, Unarmored Fast Cruisers), France (Armored Fleet, Unarmored Fast Cruisers), Germany, Greece, Holland, Italy, Japan, Norway and Sweden, Peru, Portugal, Russia, Spain, Turkey, United States.

THE PRINCIPAL BATTLES OF TWENTY YEARS—1860—1880.

Bombardments of Earthworks.—Hatteras Inlet, Hilton Head, Fort Henry, Roanoke Island, Fort Donelson, Fort Darling, Fort Hindman, Grand Gulf, Simonoseki, Kagosima, Fort Wagner, Fort McAllister, Fort Fisher, Danube Forts, Callao.

Bombardments of Masonry Forts.—Fort Sumter, Forts Jackson and St. Philip.

Passages of Forts.—Forts Jackson and St. Philip, Vicksburg Earthworks, Port Hudson Earthworks, Fort Morgan, Vicksburg Earthworks (second time).

Assaults.—Fort Sumter, Fort Fisher, Korean Forts.

Deliberate General Actions.—Memphis, Helgoland, Lissa.

Dashes.—Passages of the Mississippi, Vicksburg, Charleston.

Iron-Clads against Wooden Vessels.—Hampton Roads, Roanoke River, Albemarle Sound, Black Sea, Ylo Bay, Iquique Harbor.

Duels.—Monitor and Merrimac; Alabama and Hatteras; Weehawken and Atlanta; Kearsarge and Alabama; Meteor and Bouvet; Almirante Cochrane, Blanco Encalada, and Huascar.

PART II.—NAVAL ORDNANCE.....	175
------------------------------	-----

Austria.—Tables of Weight and Measurement. Uchatius Construction.

Argentine Confederation, Brazil, Chili, China, Denmark

England.—Tables of Weight and Measurement. Woolwich Guns, Armstrong Guns. Gun-Carriages. Gunpowder. Cartridges. Projectiles. Fuses. Primers. Sights. *Palliser Construction, Whitworth Construction, Vavasseur Construction.*

<i>France</i> .—Tables of Weight and Measurement. Guns. Carriages. Gunpowder Cartridges. Projectiles. Fuses. Primers. Sights. Accessories.	
<i>Germany</i> —Tables of Weight and Measurement. Guns. Carriages, Gunpowder Projectiles. Fuses.	
<i>Italy</i> —Tables of Weight and Measurement. Guns.	
<i>Greece, Holland, Japan.</i>	
<i>Sweden and Norway</i> .—Tables of Weight and Measurement. Guns. <i>Nordenfelt Machine-Gun, Palmcrantz Machine-Gun.</i>	
<i>Russia</i> .—Tables of Weight and Measurement. Guns.	
<i>Peru, Portugal, Spain, Turkey.</i>	
<i>United States</i> .—Tables of Weight and Measurement. Guns. Carriages. Gunpowder. Projectiles. Fuses. Sights. Accessories. <i>Hotchkiss Machine-Gun, Gatling Machine-Gun.</i>	
<i>Small-Arms</i> .—Snider, Tabatière, Krnka, Springfield, Peabody-Martini, Werndl, Mauser, Le Gras (Chassepot), Berdan, Remington, Hotchkiss Magazine.	
Recapitulatory Table of Naval Ordnance. Penetration Tables.	
PART III.—TORPEDOES	323
Whitehead, Lay, Harvey, Menzing, French Towing, American Spar-Torpedo. <i>Torpedo Vessels</i> —Pietro Micca, Ran, Ziethen, Vesuvius, Uzreef, Alarm, Intrepid, Destroyer, Uhlan. <i>Torpedo Boats</i> —Thornycroft, Yarrow, Herreshoff; Ship's Boats; Submarine Boats. Drifting Torpedoes. Defences against Torpedoes. <i>Defensive Torpedoes</i> —Frame Torpedo, Brooks's Torpedo, Singer's Torpedo, Barrel Torpedo. Torpedo Fuses. Clearing Channels of Torpedoes. Actions with Torpedoes during twenty years.	
PART IV.—ARCHITECTURE AND CONSTRUCTION.....	355
Architectural Development of the Unarmored Fleet; Chart of the Architectural Development. Constructional Development of the Unarmored Fleet—Wooden Construction, Diagonal Construction, Composite Construction, Iron Construction, Iron Sheathed with Wood. Architectural Development of Armored Vessels. Ratios of the Principal Elements of Iron-clad Vessels to their Displacement.	
PART V.—PERSONNEL; BUDGETS.....	397
Argentine Republic, Austria, Brazil, Chili, England, France, Germany, Holland, Italy, Japan, Norway and Sweden, Russia, Spain, Turkey, United States, Denmark, Greece, Peru, Portugal. Table of Budgets of Sixteen Navies, from 1875 to 1880.	

PART I.

FLEETS.



FLEETS.

ARGENTINE.

ARGENTINE CONFEDERATION IRON-CLADS.

TYPE AND NAME.		Length between Perpendiculars.	Breadth of Beam.	Draft.	Displacement.	Indicated Horse-power.	Maximum Speed.	Armor.	Backing.	BATTERY.
		Ft.	Ft.	Ft.	Tons.		Knots.	In.	Ft.	
Single-turreted Monitors.	El Plata....	165	44	10½	1,800	750	12	5½	12	II 9-inch Armstrong.
	El Andes....	165	44	10½	1,800	750	12	5½	12	II 9-inch "

GENERAL-SERVICE FLEET.

TYPE AND NAME.		Displacement.	Guns.	TYPE AND NAME.		Displacement.	Guns.
		Tons.				Tons.	
Iron Screw Gun-boats.	Parana	800	4	Gun-boats.	Coronel Paz.....	700	3
	Uruguay	800	2		Pavon.....	600	2
	Constitucion.....	750	1		Gualeguaz	300	1
	Republica.....	750	1	Paddle Gun-boats.	Luisita.....	120	1
	Bermejo	750	1		Choelechoel.....	120	1
	Pilcomayo	750	1		Gonzalo.....	150	1
	Almirante Brown.....	1,000	6		Rio Negro.....	220	1
	Vigilante.....	400	1	Torpedo vessels.....Thornycroft.			
	Resguando.....	400	1				

EL PLATA.

EL ANDES.

High-sided ram monitors. Armored belt, casemate, and single turrets. Ram bow and round stern. Twin screws and half sail-power. (See Buffel, Dutch.)

PARANA.

URUGUAY.

Iron, second-class corvettes, sheathed with wood, carrying two 6½-inch pivots amidships, two 20-pdrs. in broadside, and a

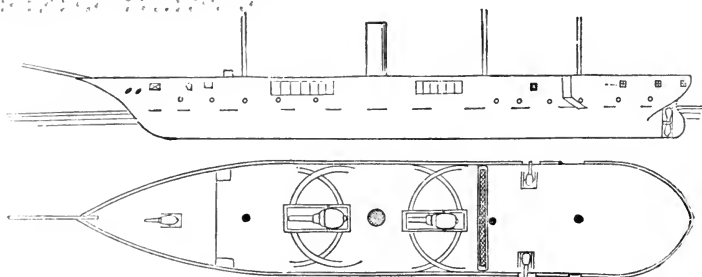

light fore-castle gun. Covered poop and fore-castle. Bridge just forward of the main-mast. Single screw, full sail-power.

CONSTITUCION.

REPUBLICA.

BERMEJO.

PILCOMAYO.

Iron, double-screw, second-class gun-boats, carrying one 12-inch gun firing through a bow-port. (See Alpha, Chinese.)

AUSTRIA.

ARMORED FLEET.

TYPE AND NAME.	Length between Perpendiculars.		Breadth of Beam.		Maximum Draft.		Displacement.		Construction Material.		Greatest thickness of Armor.		Backing.		Indicated Horse-power.		Maximum Speed.		Date of Launch.		BATTERY.	
	Ft.		Ft.	In.	Ft. in.	Tons.			In.	In.	In.	In.	In.	Knots.	Year.							
Redoubt Frigates.	287		71		26 7	7,390	Iron	14½	10	7,200	14	1878	VI 11-inch Krupp.									
Redoubt Frigates.	302		58		25 10	7,060	"	0	7	4,650	14	1872	VIII 10-inch "									
Redoubt Frigates.	276		54		23 3	5,940	"	8	8	4,000	13½	1872	VIII 9-inch "									
Redoubt Frigates.	275		55		23 2	6,080	Wood	6¼	28	3,700	13½	1869	XII 9-inch "									
Casemate Frigates.	264		59		25 8	5,810	"	6¼	29	3,130	12½	1871	X 9-inch Armstrong.									
Casemate Frigates.	222		44		22 6	3,550	Iron	8	8	2,900	13	1875	VIII 8¼-inch Krupp.									
Casemate Frigates.	222		44		22 6	3,550	"	8	8	2,866	13¼	1875	VIII 8¼-inch "									
Casemate Frigates.	222		44		22 6	3,550	"	8	8	2,900	13	1876	VIII 8¼-inch "									
Broadside Frigates.	253		51		24 10	5,140	Wood	5	26	2,912	12½	1865	XIV 7-inch Armstrong.									
Broadside Frigates.	253		51		24 10	5,140	"	5	26	3,000	12½	1865	XIV 7-inch "									
Broadside Frigates.	197		44		21 3	3,110	"	4¾	23½	2,060	11½	1861	X 7-inch "									
Montez Frigates.	160		27		3 6	310	Iron	2	8	320	8½	1871	II 5¾-inch Warendorf.									
Montez Frigates.	160		27		3 6	310	"	2	8	320	8½	1871	II 5¾-inch "									
Spalato.	Experimental single-turreted citadel-ship.																					

TEGETTHOFF.

Partial armored belt and long redoubt. Ram bow, straight overhanging stern. The armored belt encircles the water-line aft and as far forward as the commencement of the bow-frames, where it ends in an armored bulkhead, the lower edge being carried forward in a heavy steel deck, the thickness of the belt being carried out to the bow with cork filling. The belt rises to the height of the main-deck beams. The

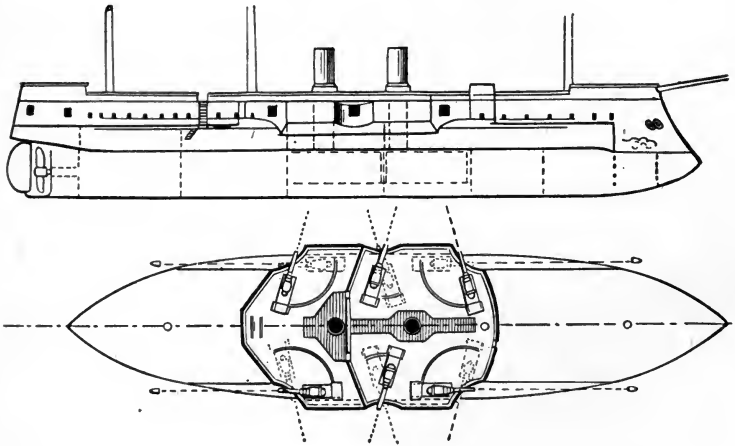

TEGETTHOFF.

redoubt has an overhang of five feet, being cut back in the wake of the centre-ports as a protection to the muzzles of the guns. The corners are cut and hollowed for angular ports, giving bow and beam fire. The sides are given a rank tumble home forward and abaft the redoubt, to open the fore-and-aft fire. An armored pilot-house rises well above the spar-deck rail at the forward end of the redoubt. A heavily armored athwartship bulkhead crosses the redoubt just abaft the forward guns as a protection from raking fire. Three-quarter sail-power, barkentine rig, single screw.

CUSTOZA.

ERZHERZOG ALBRECHT.

Armored belt and *double-decked* casemate; ram bow, round overhanging stern, single screw, full sail-power. The armored

belt encircles the water-line to the height of the main-deck beams, the casemate rising sheer to the top of the spar-deck rail. Forward, the side is carried back from the main-deck up,

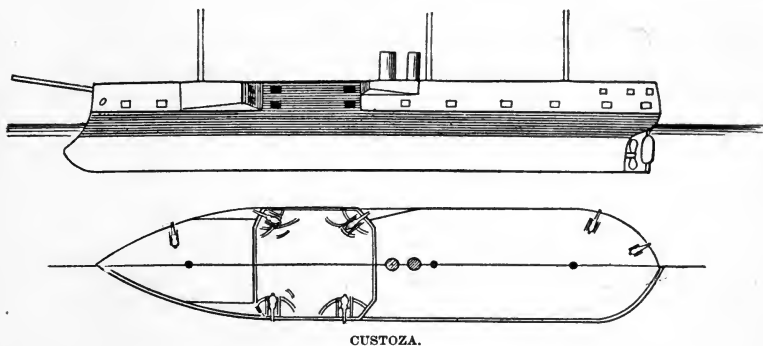

parallel to the keel, to open bow-fire from the forward guns. Aft, the side is recessed for the upper deck alone. Stern-fire is secured from a single unprotected heavy spar-deck rifle working in three ports for stern and beam fire. The Albrecht has 1200 tons less displacement than the Custozza, with a lighter battery and a speed one half knot less. The casemate guns each work in two ports for fore-and-aft and beam fire.

LISSA.

KAISER.

Armored belt, casemate, and spar-deck redoubt. Ram bow, round overhanging stern, single screw, full sail-power. The belt encircles the ship to the height of the main-deck beams. There is no fore-and-aft fire from the casemate, that being secured by an upper-deck redoubt mounted on the forward end of the casemate and having an overhang of about five feet. (See Sultan's spar-deck redoubt.) Mixed construction, the armored part of the hull being of wood and the unarmored upper works of iron.

DON JUAN.

KAISER MAX.

PRINZ EUGEN.

Armored belt and casemate, ram bow, round overhanging stern, single screw, full sail-power. The belt encircles the water-line to the height of the main-deck beams, coming down forward in a curve over the point of the ram. The casemate rises to the spar-deck beams. The side forward on the main-

deck is recessed to open forward fire from the casemate. No after-fire from the casemate, that being secured by unprotected

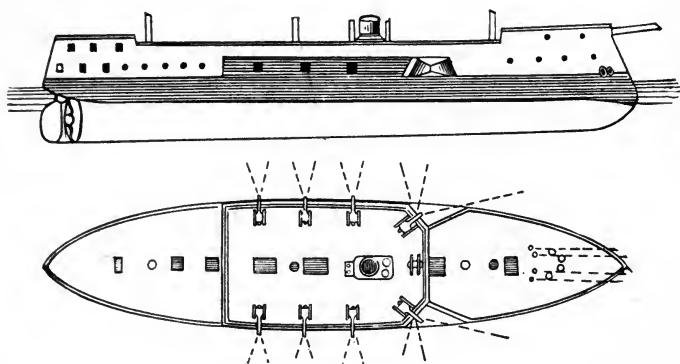

DON JUAN.

light stern-guns. These ships are rebuilt from broadside iron-clads.

FERDINAND MAX.

HAPSBURG.

SALAMANDER.

Broadside frigates; ram bow, round stern, single screw, full sail-power. The armor is complete from below the water-line to the spar-deck beams, coming down forward in steps, below the point of the ram, to give a heavy support and a strong

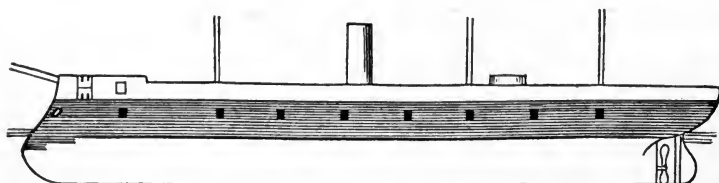

FERDINAND MAX.

junction between the wooden hull and the armor. Armored pilot-house just abaft the main-mast. There is a light armored traverse forward, forming the forward part of the spar-deck rail and protecting a bow-gun working in two large bow-ports for fore-and-aft and beam fire. The Ferdinand Max is the frigate that sank the *Re d'Italia* by ramming at the battle of Lissa.

MAROS.

LEITHA.

Single-turreted, light-draft river monitors. The freeboard is 38 inches amidships and 20 inches forward and abaft, the deck being curved fore and aft. The turret is revolved by hand, having on top of it an armored pilot-house. The weakness in the hull armor is made up by sinking the ship when going into action until only the amidship part is out of water. The bow and stern ends are completely unarmored.

SPALATO (LATE DRACHE).

Originally a sister-ship to the Salamander; now being rebuilt as a citadel-ship on the general plan of the Inflexible, but to carry one turret armed with two 17-inch rifles.

AUSTRIAN GENERAL-SERVICE FLEET.

MAROS.			LEITHA.					
TYPE AND NAME.	Displacement.	Guns.	TYPE AND NAME.	Displacement.	Guns.			
	Tons.			Tons.				
Frigates.	Radetzky.....	3,380	15	Screw Gun-boats.	Narenta.....	530	2	
	Laudon.....	3,380	15		Sansego.....	344	2	
Corvettes.	Donau.....	2,400	11	Screw Gun-boats.	Möve.....	364	2	
	Säida.....	2,400	11		Paddle Gun-boats.	Miramar.....	1,800	2
	Dandolo.....	1,690	14			Elisabeth.....	1,540	5
	Erzherzog Friedrich..	1,540	14	Garguano.....		1,355	2	
	Fasana.....	1,940	4	Triest.....		885	2	
	Helgoland.....	1,790	5	Andreas Hofer.....		816	3	
	Zrinyi.....	1,320	4	Taurus.....		560	3	
	Frundsberg.....	1,320	4	Triton.....		177	2	
	Aurora.....	1,320	4	Yachts.	Greif.....	1,330	2	
	Gun-boat.	Dalmat.....	886		4	Fantasia.....	325	
Screw Gun-boats.		Hun.....	886	4	Transports.	Pola.....	895	2
	Zara.....	815	2	Cyclop.....		2,115	2	
	Exp. Gun-boat.....	640	2	Tenders.	Grille.....	354	2	
	Nautilus.....	560	2		Gemse.....	354	2	
	Albatros.....	560	2		Alnoch.....	177		
	Kerka.....	530	2		Thurn Taxis.....	118		
Gorzowski.....					40			

School-ships. Guard-ships. Hulks. Store-ships. Thornycroft torpedo-boats rigged for Whitehead torpedoes.

SOLIMÕES.

JAVARI.

Double-turreted, low-freeboard monitors of the American type. No overhang. Twin screws. Guns loaded by hydraulic

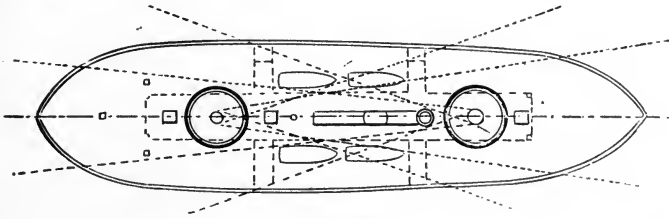
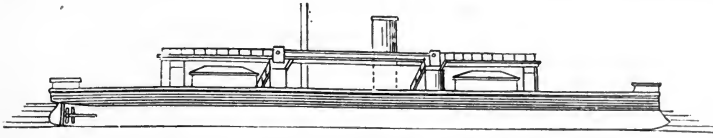

SOLIMÕES.

apparatus outside the turrets. No port stoppers or shutters. Magazines and shell-rooms under the turrets. Pilot-house just abaft the forward turret. Flying deck communicating with the lower deck by a musket-proof passage, and armed with two 9-pdr. Whitworth rifles and two Gatling guns for defence against torpedo-boats. Armor of decreasing thickness at bow and stern. Boats stow on the flying deck without davits, being hoisted in and out by a derrick and the signal-mast. Water-closets and bath-rooms on the flying deck.

LIMA BARROS.

SILVADO.

BAHIA.

Double-turreted, high freeboard vessels with a drop rail; three-quarter sail-power. (See Prinz Hendrik, Dutch.) The Silvado is unseaworthy.

BRAZIL.

Armored belt and casemate; ram bow, round stern. The

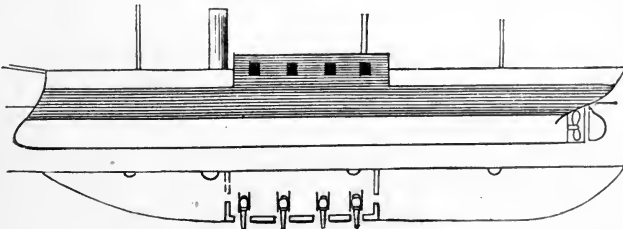

BRAZIL.

belt encircles the water-line to the height of the upper deck.

The casemate springs up sheer from the upper deck with ports in all four faces for all-around fire. There is no direct communication between the forward and after parts of the vessel except through the casemate ports. Single screw, full sail-power.

CABRAL.

COLOMBO.

Similar to the Brazil, but smaller. In these vessels the casemate is divided into two sections by the engine, which projects into it.

TAMANDARE.

BARROSO.

Similar to the Brazil, but smaller and having no fore-and-aft fire at all.

THE SIX RIVER MONITORS.

Single-turreted, light-draft river monitors, the turrets being square and mounted on turn-tables.

BRAZILIAN WOODEN FLEET.

(STEAM.)

TYPE AND NAME.		Guns.	TYPE AND NAME.		Guns.
Screw Frigate.	Amazonas	14	Paddle-wheel Gun-boats.	Greenhalgh	2
	Nietheroy.....	14		Taquary	4
Corvettes.	Trajano.....	3		Henrique Martins.....	2
	Vital de Oliveira.....	6		Felippe Camarão	1
	Magé.....	8		Bonifacio.....	2
Paddle Corvete	Belmonte	3	Braconnot.....	1	
	Paraense.....	4	Apa	1	
Screw Gun boats.	Araguary	3	Tenders.	Moema.....	2
	Pedro Affonso.....	1		Lamego.....	1
	Forte de Coimbra.....	1		Antonio João.....	2
Paddle-wheel Gun-boats.	Ypiranga	2	Corumba.....	2	
	Henrique Diaz.....	1	Paddle-wheel Transports.	Madeira.....	
	Vidal de Negreiros.....	1		Punes	
	Fernandes Vieira.....	1		Leopoldina.....	
				Werneck.....	

ALMIRANTE COCHRANE.

BLANCO ENCALADA.

Armored belt and redoubt, ram bow, round stern, twin screws, three-quarter sail-power. The armored belt encloses the water-line to the height of the main-deck beams. The redoubt is crenelated, the after-part having an overhang of about

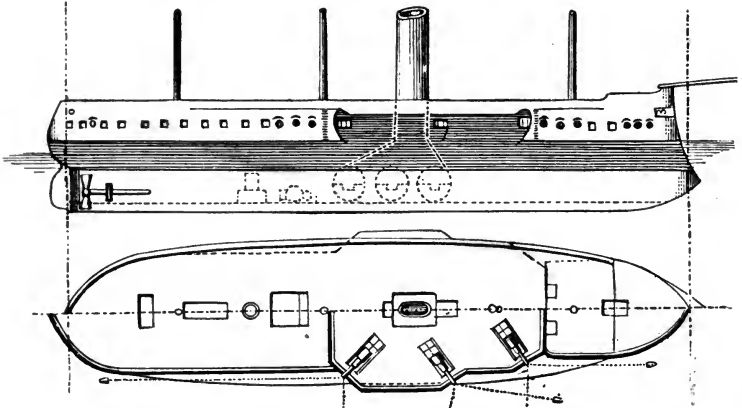

ALMIRANTE COCHRANE.

five feet, thus giving clear forward fire to the first two *pairs* of guns. The ship's side forward and abaft the redoubt is given a rank tumble home to open the fire. Clear, flush upper deck.

HUASCAR.

Sea-going turret vessel. Swan-breasted ram bow, pointed

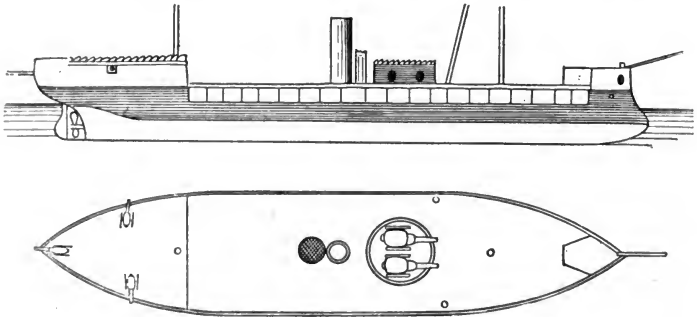

HUASCAR.

stern, single screw, three-quarter sail-power. Armored belt encircling the water-line to the height of the upper-deck beams.

Tripod fore-mast with the single turret just abaft it. No direct bow-fire on account of a topgallant forecastle, and no direct stern-fire from the turret owing to a poop-cabin. Light, unprotected poop-guns secure fire in this direction. Drop-rail in wake of the turret. Armored pilot-house just abaft turret. (Captured in 1879 from the Peruvians.)

CHINA.

TYPE AND NAME.	Length between Perpendiculars.	Breadth of Beam.	Maximum Draft.	Displacement.	Indicated Horse-power.	Maximum Speed.	BATTERY.
2 Frigates.							
13 Light River Gun-boats.	Ft.	Ft.	Ft.	Tons.		Knots.	
River Gun-boats.							
Alpha	118	27	9	325	300	9	I 11-inch Armstrong.
Beta	118	27	9	325	300	9	I 11-inch "
Gamma	120	30	9	400	340	9	I 12½-inch "
Delta	120	30	9	400	340	9	I 12½-inch "
Chin Pei	125	29	10½	440	389	10	I 12-inch "
Chin Shan	125	29	10½	440	389	10	I 12-inch Vavasour.
Fu Shing	125	29	10½	440	389	10	I 12-inch "
Lung Lang	125	29	10½	440	389	10	I 12-inch "

Torpedo-boats. Transports. Junks. Hulks. Guard- and School- Ships.

RIVER GUN-BOATS.

Iron, twin-screw gun-boats, carrying one heavy gun firing through a musket-proof bow-port. Hydraulic loading apparatus underneath the covered fore-castle. Magazine and shell-rooms under the gun, with side-hatches and railways for transporting the ammunition to the muzzle. Bridge across the after-part of the high musket-proof rail, with steering-wheel

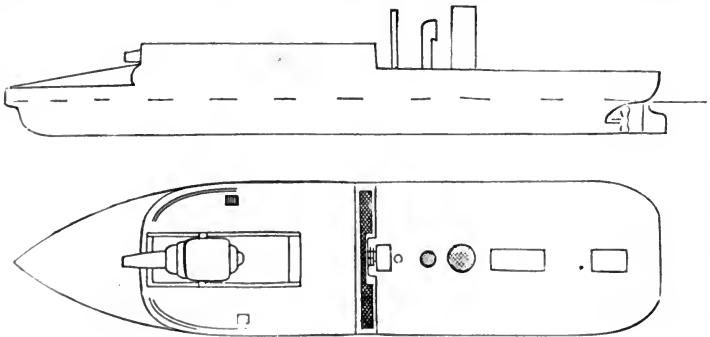

ALPHA.

just abaft it and so low as only to permit the helmsman's head to come above the rail. After-rail low, with a musket-proof booby-hatch over the engine-room.

DENMARK.

ARMORED FLEET.

TYPE AND NAME.	Length between Perpendiculars.	Breadth of Beam.	Maximum Draft.	Displacement.	Construction Material.	Greatest thickness of Armor.	Backing.	Indicated Horse-power.	Maximum Speed.	Date of Launch.		BATTERY.
										Year.	Year.	
Frigates { Denmark.....	269	49	19½	4,665	Iron	5	18	1,007	8.1	1864	1864	XII 8-inch Armstrong. XII 36-pdr. smooth-bore.
Monitors { Peder Skram.....	225	49	22	3,325	Wood	5	26	1,080	11.7	1864	1864	VIII 8-inch Armstrong. VIII 36-pdr. smooth-bore.
Monitors { Rolf Krake.....	185	38	10½	1,325	Iron	4½	9	750	7.8	1863	1863	II 8-inch Armstrong.
Monitors { Lindormen.....	216	39	14¾	2,050	"	5½	5¾	1,560	12	1868	1868	II 9-inch "
Casemate Ships { Gorm.....	232	40	15	2,310	"	8	9¾	1,670	12.2	870	870	II 10¼-inch " II 12-inch Krupp.
Casemate Ships { Helgoland.....	257	59	19	5,350	"	12½	10	3,700	13	1878	1878	IV 10¼-inch " V 5½-inch "
Casemate Ships { Odin.....	237	48	16½	3,040	"	8	10	2,260	12.4	1872	1872	IV 10¼-inch " III 8-inch Armstrong.
Iron-clad Gun-boats { Ingolf.....	150	26	13	850	"	2½	..	700	13	1867	1867	III "
Iron-clad Gun-boats { Absalon.....	135	25	12	520	"	2½	..	700	13	1869	1869	III "
Iron-clad Gun-boats { Esbern Snare.....	135	25	12	520	"	2½	..	700	13	1869	1869	III "
Iron-clad Gun-boats { Fylla.....	140	25½	12	550	"	2½	..	700	13	1869	1869	III "
Iron-clad Gun-boats { Diana.....	140	25½	12	550	"	2½	..	700	13	1869	1869	III "

DANISH UNARMORED FLEET.

TYPE AND NAME.			Displacement.	Guns.	TYPE AND NAME.			Displacement.	Guns.
			Tons.					Tons.	
Frigates.	Niels Juel.....	2,350	26	Gun-boats.	Storebelt.....	240	1		
	Sjælland.....	2,350	26		Lillebelt.....	240	1		
	Jylland.....	2,420	26		Thure.....	145	2		
Corvettes.	Heimdal.....	1,175	14		Schrøedersee.....	145	2		
	Dagmar.....	1,176	14		Willemöes.....	145	2		
	St. Thomas.....	1,546	5		Krieger.....	145	2		
Gun-boats.	Falster.....	350	1		Marstrand.....	145	2		
	Möen.....	350	1		Hauch.....	95	1		
	Öresund.....	240	1		Drogden.....	50	1		

DANMARK.

PEDER SKRAM.

Broadside iron-clad frigates (See Ferdinand Max, Austrian), still capable of forming part of cruising fleet, but of little use beyond harbor defence.

ROLF KRAKE.

Monitor gun-boat, having a superstructure forming a covered forecastle forward and officers' quarters aft, the upper line

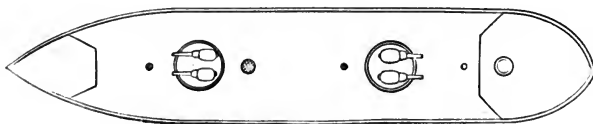
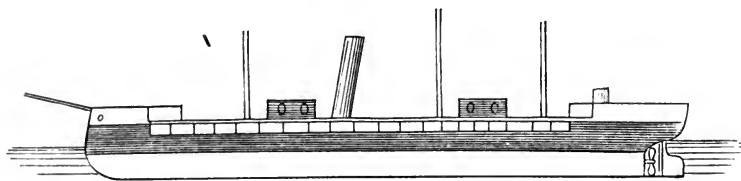

ROLF KRAKE.

of the superstructure being carried along by a rail in wake of the turrets, which may be dropped in action. Her turrets are small, containing one gun each and capable of being turned by hand or by steam (Coles system). The armored belt comes

to the height of the deck-beams, and the deck is convex, plated with $\frac{3}{4}$ -inch steel. An armored pilot-house is placed well aft. She has full sail-power.

LINDORMEN.

GORM.

Single-turreted, breast-work, light-draft monitors. (See Buffel, Dutch.)

HELGOLAND.

Casemated iron-clad frigate with complete armored belt. No bow or stern fire from the casemate, which carries four 10 $\frac{1}{4}$ -inch Krupp rifles. Forward on the upper deck is placed a 12-inch Krupp pivot for bow and beam fire. Her armor at the water-line is 12 inches, diminishing to 6 at the bow and stern. She is provided with apparatus for discharging Whitehead torpedoes from each beam above water.

ODIN.

Armored belt with elevated casemate. (See Brazil, Brazilian.) The casemate contains four 10 $\frac{1}{4}$ -inch Armstrong muzzle-loaders, each of which fires from two ports. She has no spars except signal-masts.

INGOLF.

ABSALON.

ESBERN SNARE.

FYLLA.

DIANA.

Armored gun-boats, having fine lines and an armored belt from two feet below the water-line to the deck-beams. Three

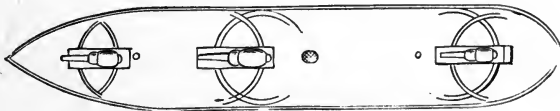
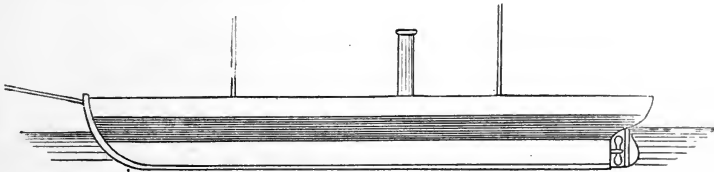

INGOLF.

unprotected pivot-guns working amidships on centre-pivot carriages and firing over the rail. Full sail-power and hoisting screw.

The wooden fleet is of the ordinary type of old-style steam corvettes and gun-boats.

ENGLAND.

ARMORED FLEET.

TYPE AND NAME.	Length between Perpendiculars.		Breadth of Beam.		Maximum Draft.		Displacement.		Construction Material.		Greatest thickness of Armor.		Least thickness of Armor.		Backing.		Indicated Horse-power.		Maximum Speed.		BATTERY.	
	Ft. in.		Ft. in.		Ft. in.		Tons.		In.		In.		In.		In.		Knots.					
Warrior.....	380		58		26 5		9,681		Iron	4½	4½	4½	18	5,469	14.3	VIII 8-inch Woolwich.						
Black Prince.....	380		58		27		9,681		"	4½	4½	18	5,772	13.6	VIII 8-inch XX 7-inch							
Achilles.....	383		58		27 4		9,681		"	4½	3	18	5,722	14.3	XIV 9-inch II 8-inch							
Northumberland.....	400		59 5		27		10,395		"	5½	3	9	6,558	14.1	VII 9-inch XX 8-inch							
Defence.....	280		54		25 6		6,074		"	4½	4½	18	2,437	11.6	II 8-inch XIV 7-inch							
Resistance.....	280		54		26		6,074		"	4½	4½	18	2,428	11.6	II 8-inch XIV 7-inch							
Hector.....	280		56 5		25 7		6,960		"	4½	3	18	3,256	12.5	IV 8-inch XIV 7-inch							
Valiant.....	280		56 5		26 10		6,420		"	4½	3	18	3,500	12.5	IV 8-inch XIV 7-inch							
Lord Warden.....	280		58 9		26		7,675	Wood	7	4	4	31	6,706	13.5	XVIII 7-inch							
Repulse.....	252		59		26 2		6,190	"	5	4	4	30½	3,347	12.2	XII 8-inch							
Agincourt.....	400		59 5		27		10,395	Iron	5½	3	3	9	6,807	15.4	XVII 9-inch							
Minotaur.....	400		59 5		27		10,395	"	5½	3	3	9	6,702	14.4	XVII 9-inch							
Bellerophon.....	300		56		26		7,540	"	7½	5	5	9¾	6,521	14.1	X 9-inch V 7-inch							
Swiftsure.....	280		55		26 2		6,660	Iron sheathed	9¼	4	4	9¾	4,913	13.5	X 9-inch IV 64-pdr.							
Triumph.....	280		55		26 2		6,660	"	9¼	4	4	9¾	4,862	13.5	X 9-inch IV 64-pdr.							
Audacious.....	280		54		23		6,034	"	9¼	4	4	9¾	4,021	12.8	X 9-inch IV 64-pdr.							

Armored Frigates.

Casemate Ships.

Invincible.....	280	54	23	6,034	Iron sheathed	9¼	4	9¾	4,832	14	X 9-inch Woolwich.
Iron Duke.....	280	54	23	6,034	"	9¼	4	9¾	4,268	13.6	IV 64-pdr. 9-inch
Hercules.....	325	59	26 5	8,700	Iron	11	6	9¾	7,200	13.2	VIII 64-pdr. 10-inch
Sultan.....	325	59	27 6	9,286	"	10½	6	9¾	8,620	14.1	II 9-inch 7-inch
Alexandra.....	325	63 8	26 6	9,492	"	13½	6	9¾	8,615	15	VIII 10-inch 9-inch
Temeraire.....	285	62 2	27 1	8,412	"	12½	7	9¾	7,700	14 6	II 12-inch X 10-inch
Superb.....	333	59	25	8,994	"	13½	7	11.8	7,430	13.8	IV 12-inch IV 10-inch
Shannon.....	260	54	22 6	5,103	"	10½	6	9¾	3,370	12.6	XII 10-inch IV 7-inch
Nelson.....	280	60	24 2	7,323	"	10½	6	9¾	6,000	14	II 10-inch VII 9-inch
Northampton.....	280	60	24 2	7,323	"	10½	6	9¾	6,000	14	VIII 9-inch IV 10-inch
Prince Albert.....	240	48 1	19 8	3,900	"	5	4½	18	2,128	11.6	VIII 9-inch IV 9-inch
Scorpion.....	224 6	42 4	16 3	2,777	"	5	4½	9	1,450	10.2	IV 9-inch
Wyvern.....	224 6	42 4	15 8	2,725	"	5	4½	9	1,450	10.2	IV 9-inch
Cyclops.....	225	45	16 5	3,430	"	9¼	5	9¾	1,660	11	IV 10-inch
Gorgon.....	225	45	16 5	3,430	"	9¼	5	9¾	1,660	11	IV 10-inch
Hecate.....	225	45	16 5	3,430	"	9¼	5	9¾	1,755	11	IV 10-inch
Hydra.....	225	45	16 5	3,430	"	9¼	5	9¾	1,472	11	IV 10-inch
Glutton.....	245	54	19	4,912	"	13½	9	18	2,868	12.1	IV 10-inch
Monarch.....	329	57 6	26	8,322	"	8½	5	11¾	7,842	14.9	II 12-inch IV 12-inch
Devastation.....	285	62 3	26 3	9,157	"	13½	8½	18	6,652	13.8	IV 12-inch I 7-inch
Thunderer.....	285	62 3	26 3	9,157	"	13½	8½	18	6,270	13.4	IV 12-inch II 12½-inch
Neptune.....	300	63	25 2	8,900	Iron sheathed	13½	7	9¾	9,100	14.6	II 12½-inch IV 12½-inch
Dreadnought.....	320	63 10	27	10,886	Iron	15½	7	18	8,000	14	II 7-inch IV 12½-inch
Ajax.....	260	66	24	8,492	"	13½	11	18	6,000	13	IV 12½-inch

Casemate Ships.

Armored Water-line.

Armored Turret Ships for Coast Defence.

Turret Ships for Coast Defence.

Sea-going Turret Ships.

ENGLISH ARMORED FLEET—(CONTINUED.)

TYPE AND NAME.	Length between Perpendiculars.	Breadth of Beam.	Maximum Draft.	Displacement.	Construction Material.	Greatest thickness of Armor.	Least thickness of Armor.	Backing.	Indicated Horse power.	Maximum Speed.	BATTERY.
	Ft. in.	Ft. in.	Ft. in.	Tons.		In.	In.	In.		Knots.	
Agamemnon.....	260	66	24	8,462	Iron	19½	11	18	6,000	13	IV 12½-inch Woolwich.
Indefatigable.....	320	75	25 4	11,500	"	24	18	18	8,000	14	IV 16-inch "
Conqueror.....	IV 17-inch Armstrong.
Orion.....	245	52	19 6	4,700	"	13½	6	9¾	3,900	13	IV 12-inch "
Bellisle.....	245	52	19 6	4,700	"	13½	6	9¾	3,955	13	IV 12-inch "
Pallas.....	225	50	24 3	3,797	Wood	5	3	22	3,581	13.4	IV 8-inch "
Penelope.....	260	50	17 4	4,334	Iron	6	3	9¾	4,703	12.8	II 64-pdr. "
Research.....	165	38 6	15 5	1,780	Wood	5	3	16¾	1,042	10.3	II 40-pdr. "
Hotspur.....	225	50	20 8	4,012	Iron	12	6	11½	3,497	12.6	III 40-pdr. "
Rupert.....	250	53	23 6	5,358	"	9½	6	11½	4,635	12.4	VIII 8-inch Woolwich.
Viper.....	160	32	11 7½	1,220	"	5	3	6	696	9	IV 7-inch "
Vixen.....	160	32	11 7½	1,220	"	5	3	6	740	9	IV 7-inch "
Waterwitch.....	162	32 1	11 9	1,279	"	5	3	6	777	9.2	IV 7-inch "
Abyssinia.....	225	42	14	2,901	"	7	4½		1,300	9.6	IV 10-inch "
Magdala.....	225	45	14 8	3,344	"	8	5	9	1,400	9.7	IV 10-inch "
Cerberus.....	225	45	14 3	3,344	"	8	5	9	1,400	9.7	IV 10-inch "
Erebus.....	1,814	"	4½	4½	24	483	6.0	XVI 64-pdr. "
Polphemus.....	240	40	2,660	"	5,500

Sea-going Turret

Armored Corvettes

Rams

Gun-boats

Gun-boats

Colonial

Turret Ships

Ramm, Battery

WARRIOR. BLACK PRINCE. DEFENCE. RESISTANCE.

Armored broadside frigates. The armor of these ships consists of a long casemate covering the battery only, and extending from about two feet below the water-line to the spar-deck

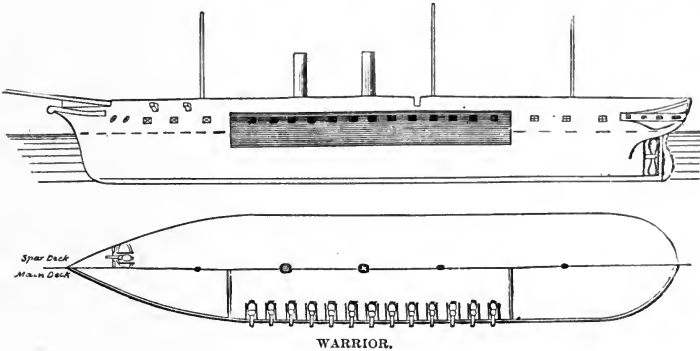

WARRIOR.

beams. The bow and stern sections are left completely unprotected, the armor forward and aft ending in athwartship bulkheads. The hull is divided into a number of very large water-tight compartments. The extreme forward part of the upper-deck rail is recessed to permit straight-ahead fire from the fore-castle guns. The bows of these ships, although not built especially for ramming, are made very heavy to permit of this mode of attack with safety. Full sail-power.

HECTOR.

VALIANT.

Armored broadside frigates with swan-breasted ram bows. The armor of these ships consists of a belt around the main-

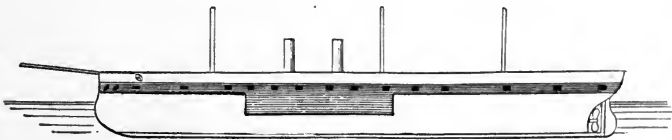

VALIANT.

deck, whilst the boilers and engines are in a casemate. The water-line forward and abaft is unprotected. Full sail-power.

ACHILLES.

Armored broadside frigate with straight bow strengthened for ramming. The armor of this ship consists of a water-line

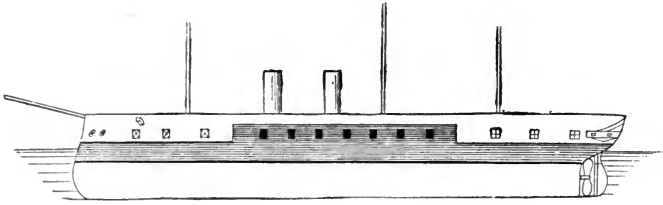

ACHILLES.

belt the height of the gun-deck beams and a casemate for the battery. Full sail-power. No bow-fire except from an unprotected forecastle gun. (See Warrior.)

NORTHUMBERLAND.

MINOTAUR.

AGINCOURT.

Armored broadside frigates, swan-breasted bow for ramming. The armor in these ships may be called complete,

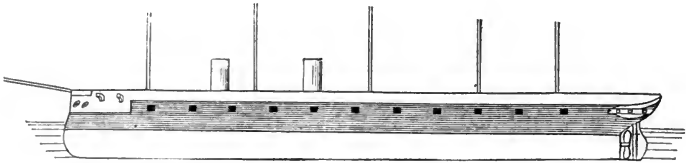

MINOTAUR.

forming a belt rising to the height of the spar-deck beams fore and aft. Full sail-power (5 masts).

BELLEROPHON.

REPULSE.

LORD WARDEN.

Armored broadside frigates with ram bows. The armor in these ships is complete, rising to the height of the spar-deck beams, and in addition having a casemated forecastle. The Lord Warden and Repulse have wooden hulls, having been

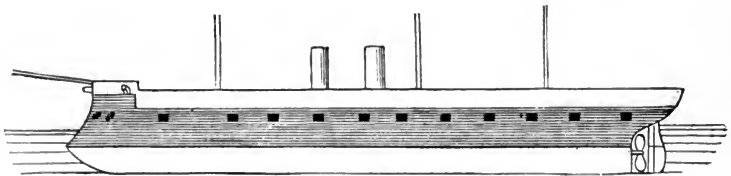

LORD WARDEN.

originally laid down for wooden line-of-battle ships. The Bellerophon carries heavier armor and more effective backing at

the water-line than any of the foregoing ships. These ships have full sail-power. The Bellerophon is a good sailer.

PALLAS.

RESEARCH.

Armored belt and redoubt, the side being cut back just forward and abaft the redoubt to permit the broadside guns to

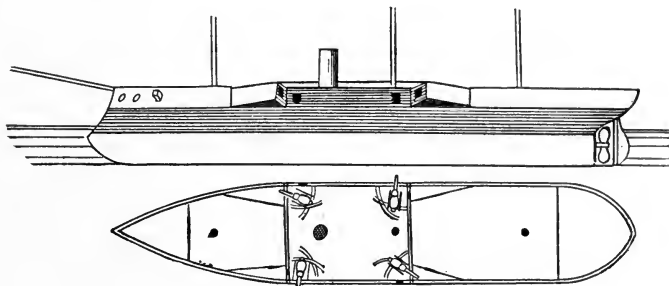

PALLAS.

fire well forward and aft through adjacent ports. These ships have wooden hulls, having been originally laid down for wooden frigates. The Pallas is a remarkably fine sailing ship.

HERCULES.

SUPERB.

PENELOPE.

Armored belt and long armored redoubt, the sides being cut back for bow-fire. The Hercules has armored breastworks

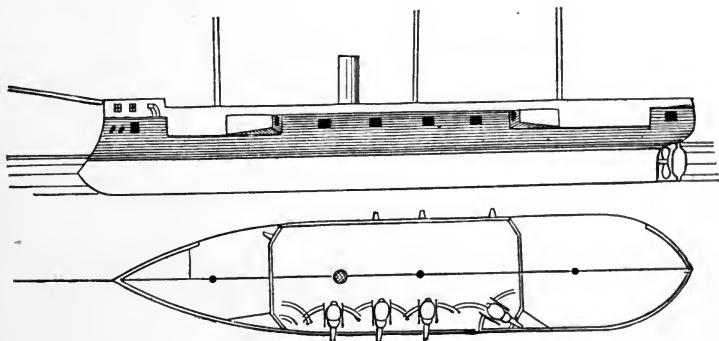

HERCULES.

at the bow and stern on the battery-deck for heavy bow and stern guns. The Superb is the late Memdoughieh (Turkish).

* The Pallas and Research were sold out of service in 1880.

SULTAN.

Armored belt and long armored redoubt. The side forward of the redoubt is cut back for forward fire, but instead of

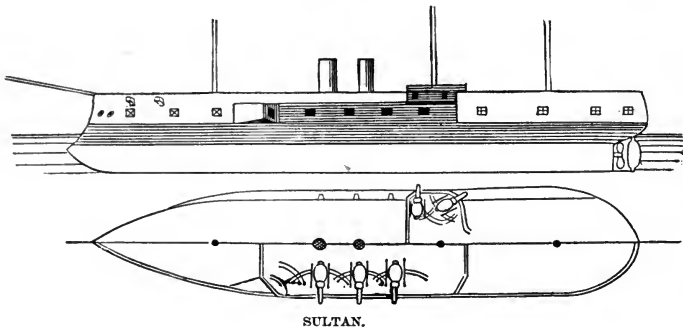

the forward and after breastworks of the Hercules, an upper redoubt is built at the after-end of the main one, projecting clear of the side, and from which clear bow and stern fire is available.

SWIFTSURE.

TRIUMPH.

AUDACIOUS.

INVINCIBLE.

IRON DUKE.

Armored belt and short casemate, on which is mounted an upper-deck redoubt. The gun-deck casemate does not permit of bow-fire, as the lines of the ship are not broken forward or abaft it. The upper redoubt projects clear of the side over the lower casemate, and has its corners cut off to permit of angular

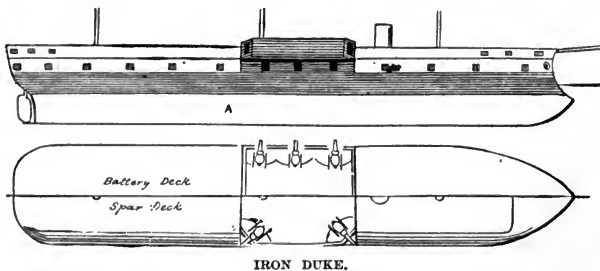

A—Wound made in the Vanguard by the Iron Duke.

ports being cut that give fore-and-aft and beam fire. This redoubt has no athwartship bulkhead. The magazines are directly under the casemates. The boat-davits are near the amidship

line, so that the boats are kept well inboard. (The Vanguard, sunk by collision with the Iron Duke, belonged to this type.)

ALEXANDRA.

Armored belt and double-decked casemate, ram bow, and overhanging stern. The forward part of the belt is carried down in a curve over the ram. The side forward from the gun-deck beams up is carried well back parallel to the keel to give fore-and-aft fire. There is no stern-fire from the main-deck casemate. The after bulkhead rises straight from the belt to the top of the upper casemate. This casemate is, however, shorter than the lower one, and its forward bulkhead being carried down

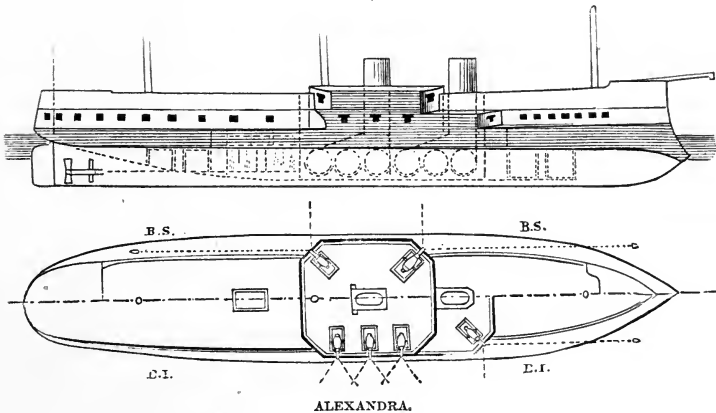

separates the main-deck casemate into two chambers, forming a double protection for the after-guns. The corners of both casemates are cut off for angular ports to give fore-and-aft and beam fire. The hull is divided longitudinally by an armored bulkhead rising to the height of the main-deck beams, one set of engines and boilers being in each compartment. Twin screws and full sail-power.

TEMERAIRE

Armored belt, redoubt, and two barbette turrets. Ram bow. The armored belt is carried down in a curve over the ram. No stern-fire from the casemate, the forward corners being cut for angular ports, and the side forward being carried back for bow-fire. The casemate is cut in two chambers similar to the main-deck casemate of the Alexandria. The barbette turrets forward and abaft the casemate are oval in shape, and

the guns are mounted on Monerieff carriages. The armor of the body of the turrets does not come below the spar-deck beams, but an armored shaft is carried down to the level of the belt, through which ammunition is passed and commu-

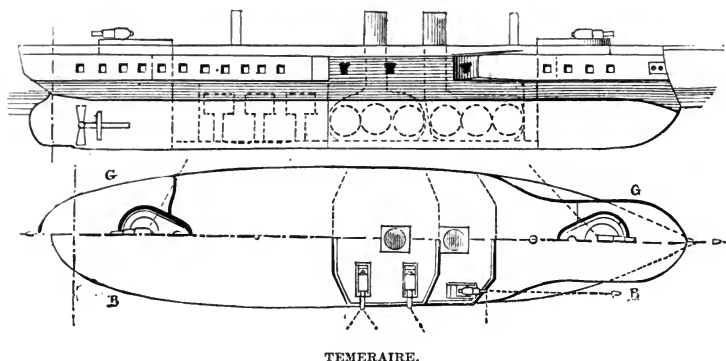

TEMERAIRE.

nication given. The hull is divided longitudinally by an armored bulkhead similar to the Alexandra. Twin screws and auxiliary sail-power. (Brig rigged.)

SHANNON.

Partial armored belt and partial spar-deck breastwork. The belt is carried around the stern as a protection to the steering-gear, but ends just abaft the foremast in an armored bulkhead,

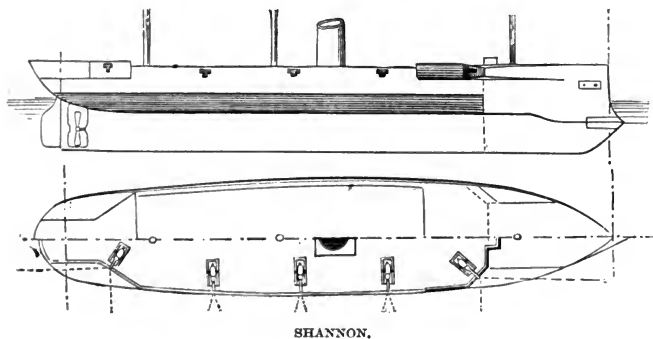

SHANNON.

which rises sheer to the height of the spar-deck rail. From the foot of this bulkhead an iron deck is carried forward to the stem, ending as a support to the ram. A breastwork on the spar-deck forward forms a protection for the bow-guns, the

topgallant forecastle being carried to its after-edge. The corners of the breastwork are cut for angular ports, and the rail forward is carried back parallel to the keel. The rail aft is recessed and cut back for after angular ports, but the guns are not protected by armor. An armored conning tower is placed at the forward part of the breastwork. A single gun is used aft, working on a turn-table for shifting from one port to the other.

NELSON.

NORTHAMPTON.

Partial armored belt and partial forward and after spar-deck breastworks. The armored belt extends for three fifths of the length of the ship amidships, ending in armored athwartship bulkheads, which rise to the height of the spar-

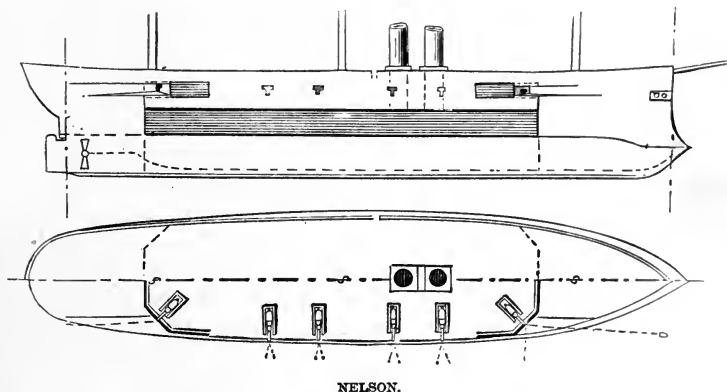

deck beams. A heavy iron deck prolongs the lower edge of the belt to the bow and stern, protecting the steering-gear aft and forming a support for the ram forward. The guns are all carried on a covered deck, giving a flush spar-deck. The breastworks on the main-deck at the bulkheads form a side protection for the forward and after guns, the corners being cut for angular ports and the side recessed for fore-and-aft fire. These ships have twin screws and an armored longitudinal bulkhead similar to the Alexandra.

MONARCH.

NEPTUNE.

Armored belt and revolving Coles turrets on the spar-deck. The belt rises to the height of the main-deck beams, and amidships is carried up to the spar-deck beams to cover the lower part of the turrets and machinery. An armored bulkhead rises

well forward, forming on the spar-deck a fore-castle breastwork for the bow-guns. The spar-deck rail in wake of the turrets may be dropped to open their fire. The Neptune has no protected stern-fire. The belt of the Monarch is carried up aft to

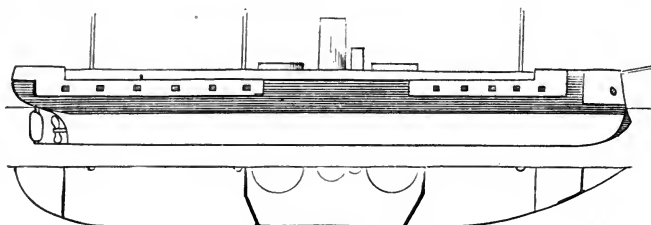

MONARCH.

the height of the spar-deck beams, forming a breastwork for the stern-guns. (See Hercules.) The Neptune is the late *Indipendenza*.

INFLEXIBLE.

AJAX.

AGAMEMNON.

CONQUEROR.

Casemated, double-turreted, mastless, sea-going iron-clads. Ram bows. The armored casemate is rectangular and encloses the middle third of the vessel. The lower edge of the casemate is prolonged fore and aft in a heavy iron deck, which forward curves down below the point of the ram. Short unarmored fore-castle and poop structures, carried along in line

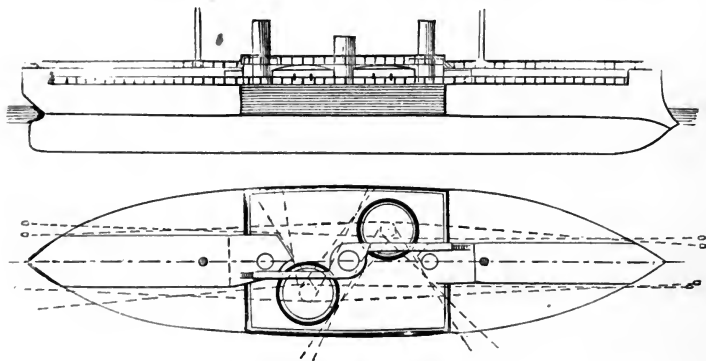

INFLEXIBLE.

with the keel to the smoke-stacks. The turrets are placed diagonally to open the full fore-and-aft fire. Forward and abaft the casemate is a cork belt of the thickness of the armor, to give

the ship floating power in case the unprotected sections are pierced. The ship is divided in two by a longitudinal bulkhead. Twin screws.

DREADNOUGHT.

ORION.

BELLEISLE.

Armored belt and breastwork, sea-going monitors. The armor is complete fore and aft, and is carried down in a curve forward below the point of the ram. Throughout the middle third a casemate rises to protect the bottom of the turrets and give them a good elevation above the water-line. Forward and abaft this casemate, and in line with it, an unarmored superstructure is carried, stopping short of the bow and stern. This

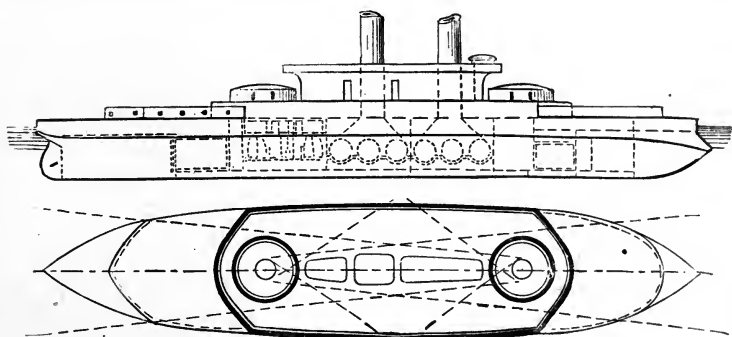

DREADNOUGHT.

forms roomy quarters and gives the ship an increased freeboard and stability. The turrets are amidships and in line with the keel. Between them is a musket-proof superstructure, expanding into a flying deck having at its forward end an armored pilot-house. Longitudinal armored bulkhead, similar to the Alexandra.

DEVASTATION.

THUNDERER.

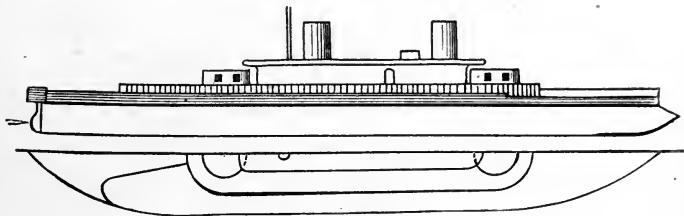

DEVASTATION.

Armored belt and breastwork, double-turreted, sea-going monitors. The armored belt from forward to the forward tur-

ret comes only to the height of the water-line. The breastwork differs from that of the Dreadnought in not coming out to the side, but the freeboard necessary is obtained by carrying around it and well forward and aft a musket-proof superstructure. A musket-proof superstructure also rises between the turrets, expanding into a flying deck with an armored pilot-house at its forward end.

GLATTON.

Armored belt and breastwork, single-turreted, coast-defence monitor. The armored belt rises to the upper-deck level, and is of the same thickness from stem to counter. It has an over-

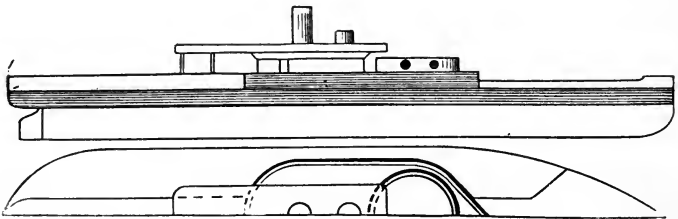

GLATTON.

hang beyond the hull of $2\frac{1}{2}$ feet amidships. The breastwork surrounds the turret and smoke-stack and does not come out to the side. Forward and abaft a narrow superstructure carries along the line of the breastwork. Aft the turret, which is situated well forward, a musket-proof superstructure rises, expanding into a flying deck, with an armored pilot-house at its forward extremity.

CYCLOPS. GORGON. HECATE. HYDRA.
 ABYSSINIA. MAGDALA. CERBERUS.

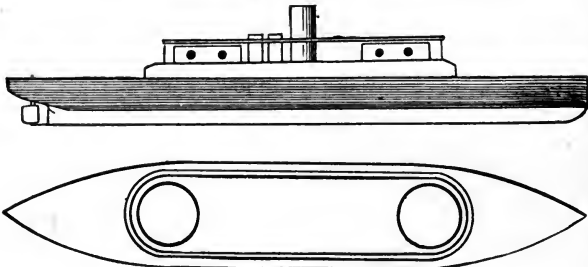

CERBERUS.

Armored belt and breastwork, double-turreted, coast-defence monitors. The breastwork occupying somewhat more than the

middle third of these vessels surrounds the turrets and smoke-stack, but does not come out to the side. Musket-proof passages or tubes and ventilators, together with an armored pilot-house, extend above a light flying deck. The Cerberus is stationed permanently at Melbourne, having had a temporary rail and upper deck built on her for her passage out. The Abyssinia and Magdala are permanently stationed at Bombay.

HOTSPUR.

RUPERT.

Armored rams. The armor-belt completely encircles the hull and is carried down in a curve forward below the point of

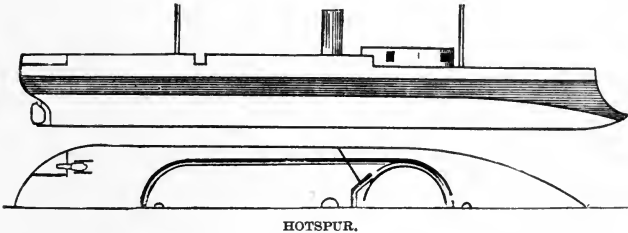

HOTSPUR.

the ram. Each vessel is provided with a breastwork and single turret. That of the Hotspur is fixed and has four ports, the gun being worked on a turn-table. That of the Rupert is of the Coles type of revolving turret. The breastwork surrounds the foot of the turret and the smoke-stack. Both vessels have a high superstructure from abaft the turret to the stern, rising two thirds the height of the turret, and each carries a stern-gun, the side being recessed at each counter for stern-fire. The Hotspur carries an armored pilot-house on top of her turret; the Rupert has two, one on each side, abaft the turret in the dead-angle. At present the turret of the Hotspur is being changed to a revolving one like the Rupert's.

PRINCE ALBERT.

Four-turreted monitor. This ship has a wooden hull, having been cut down from a line-of-battle ship. Her armor-belt encircles her hull and she has no breastwork; her Coles turrets being protected about their lower parts by the armored deck. This vessel is only fit for harbor defence.

SCORPION.

WYVERN.

Armored belt, double-turreted iron-clads with full sail-power. These vessels are high sided, the high rail between the

fore and mizzen masts dropping to unmask the turrets. The armor-belt encircles them. They have strengthened ram bows, a long, high forecastle extending to the fore-mast and making a dead-angle for the forward turret, and a high poop to the mizzen-mast, making a dead-angle for the after turret. The fore and main masts are tripod masts. These vessels are bark rigged, with full sail-power, and when their side rails are up they have the appearance of ordinary corvettes. They were built for the Confederates during the war of the American Rebellion.

VIPER.

VIXEN.

WATERWITCH.

Casemated gun-boats. These vessels have rectangular casemates about the boilers and engines (see *Inflexible*), the forward bulkhead rising above the spar-deck level, and being provided with two ports for bow-fire. They are only intended for bow-fire and end-on attack. The *Waterwitch* is a double-ender, having steering-gear at each end, and at present, instead of steam boilers and engines, she has a hydraulic motor.

POLYPHEMUS.

Armored ram. The transverse section of this ship is top-shaped, showing above water a convex upper deck surmounted by a light musket-proof superstructure. In addition to her heavy ram, she is provided with apparatus for firing the Whitehead torpedo, ahead and from each beam.

EREBUS.

Old-type casemated floating battery, completely armored.

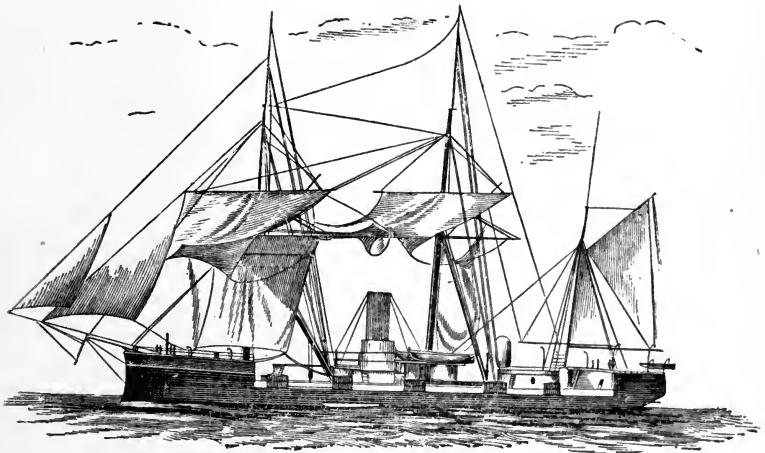

WYVERN.

ENGLISH UNARMORED FLEET.

(NEW CRUISERS.)

TYPE AND NAME.	Length between Perpendiculars.		Breadth of Beam.		Mean Draft.		Displacement.		Construction Material.		Indicated Horse-power.		Maximum Speed.		Date of Launch.		BATTERY.	
	Ft. in.	Ft. in.	Ft. in.	Ft. in.	Tons.	Tons.	Tons.	Tons.	Knots.	Knots.	Year.	Year.	Year.	Year.	Year.	Year.	Year.	Year.
Inconstant.....	333	50 1	23 7	5,782	Iron sheathed	7,361	16.5	1868	X 9-inch Woolwich.									
Shah.....	334 8	52	23	6,040	"	7,477	16.4	1875	"									
Raleigh.....	298	49	22	5,200	"	6,158	15.2	1873	"									
Boadicea.....	280	45	22	4,027	"	5,130	15.5	1875	"									
Bacchante.....	280	45	21 7	3,932	"	5,250	15.3	1876	"									
Euryalus.....	280	45	21 7	3,932	"	5,250	15.3	1875	"									
Rover.....	280	43 6	20 2	3,494	"	4,964	14.7	1875	"									
Active.....	270	42	20	3,075	Iron sheathed	4,015	14.8	1869	"									
Volage.....	270	42	20	3,078	"	4,532	15.1	1869	"									
Cleopatra.....	225	44 6	20	2,383	Steel & iron sheathed	2,300	13	Building	"									
Constance.....	225	44 6	20	2,383	"	2,300	13	"	"									
Champion.....	225	44 6	20	2,383	"	2,300	13	"	"									
Charysfort.....	225	44 6	20	2,383	"	2,300	13	"	"									
Comus.....	225	44 6	20	2,383	"	2,300	13	"	"									
Conquest.....	225	44 6	20	2,383	"	2,300	13	"	"									
Curacao.....	225	44 6	20	2,383	"	2,300	13	"	"									
Emerald.....	220	40	16 3	1,851	Composite	2,100	13	1877	"									

Frigates.

Corvettes.

ENGLISH UNARMED FLEET—(CONTINUED.)

(NEW CRUISERS.)

TYPE AND NAME.	Length between Perpendiculars.	Breadth of Beam.	Mean Draft.	Displacement.	Construction Ma- terial.	Indicated Horse- power.	Maximum Speed.	Date of Launch.	BATTERY.
Fantome.....	Ft. 160	Ft. in. 31 4	Ft. in. 13	Tons. 894	Composite	840	Knots. 11	Year. 1875	} II 7-inch, II 64-pdrs.
Flying Fish.....	160	31 4	13	894	"	to 1,000	11	and 1876	
Sappho.....	160	31 4	13	894	"		11		
Iris.....	300	46	19 9	3,735	Steel	7,750	18.5	1877	} X 64-pdrs.
Mercury.....	300	46	19 9	3,735	"	7,000	18	1878	
Vesuvius.....	90	22	8 6	260	Iron	379	8.9	1874	None.
Polyphemus.....	"	5,500	18	Building	} I 7-inch pivot amidships, I 64-pdr. " " II 20-pdrs.
Myrmidon.....	870	Wood	720	10	1867	
Arab.....	Composite	656	11	} I 7-inch midship pivot, II 64-pdrs.
Condor.....	"	770	11	
Falcon.....	700	"	720	11	1873	
Flamingo.....	774	"	750	11	to 1877	
Griffon.....	"	790	11	} I 7-inch pivot, II 40-pdrs.
Lily.....	774	"	829	11	
Bittern.....	774	"	851	10	1865	} I 7-inch pivot, II 40-pdrs.
Bullfinch.....	774	"	985	10	to 1872	

Sloops.

Dispatch
Steamers.Torpedo-Ship.
Torpedo-Dispatch
Steamers.

1st Class Gun-boats.

ENGLISH UNARMORED FLEET—(CONTINUED.)
(NEW CRUISERS.)

TYPE AND NAME.	Displacement.	Construction Material.	Indicated Horse-power.	Maximum Speed.	BATTERY.	
	Tons.			Knots.		
1st CLASS GUN-BOATS. Low-pressure Engines. Twin Screws.	774	Composite	Curlew	811	10	I 7-inch pivot. II 40-pdrs.
			Lapwing	882		
			Magpie	857		
			Philomel	961		
			Plover.....	977		
			Ringdove.....	957		
			Seagull.....	702		
			Swallow.....	892		
			Vulture.....	847		
			Woodlark.....	881		
1st CLASS GUN-BOATS. High-pressure Engines. Twin Screws.	584	Composite	Avon	528	10	II 64-pdrs. II 20-pdrs.
			Beacon	506		
			Boxer	587		
			Cracker	528		
			Dwarf.....	495		
			Elk	472		
			Flirt.....	532		
			Fly	489		
			Growler	696		
			Hart.....	608		
			Hornet.....	506		
			Lynx	526		
			Midge	472		
			Pert	502		
			Rocket	632		
			Teazer	489		
			Thistle.....	641		
592	Composite	Frolic.....	896	10	II 64-pdrs. II 20-pdrs.	
		Kestrel.....	835			
		Ready	891			
		Rifleman	715			
		Dart	336			
		570	Composite			Newport.....
Torch	281					

ENGLISH UNARMORED FLEET—(CONTINUED.)

(NEW CRUISERS.)

TYPE AND NAME.	Displacement.	Construction Material.	Indicated Horse-power.	Maximum Speed.	BATTERY.		
	Tons.			Knots.			
2D CLASS GUN-BOATS. Compound Engines, Single Screw.	455	Composite	360	9	II 64-pdr. II 20-pdr.		
						Firebrand	
						Firefly	
						Firm.....	
						Forester.....	
						Forward.....	
	430 to 455	Composite	540	515	10.1 to 10.8	II 64-pdr. II 20-pdr.	
							Ariel
							Contest
							Coquette
							Cygnets
							Decoy
							Express.....
							Foam.....
							Goshawk
							Mallard.....
							Merlin.....
Moorhen.....							
Mosquito							
Sheldrake.....							
Swinger							
Zephyr							
2D CLASS RIVER GUN-BOATS.	363	Iron	310	9.5	III 64-pdr.		
						Dee.....	
						Don.....	
						Esk.....	
						Medina	
						Medway	
						Sabrina.....	
						Slaney	
						Spay.....	
						Tay.....	
Tees.....							
Trent.....							
Tweed.....							

ENGLISH UNARMORED FLEET—(CONTINUED.)

(NEW CRUISERS.)

TYPE AND NAME.	Displacement.	Construction Material.	Indicated Horse-power.	Maximum Speed.	BATTERY.
	Tons.			Knots.	
Britomart.....	330	Wood	160 to 277	8	II 64-pdr.
Bruiser.....					
Cherub.....					
Cockatrice.....					
Cromer.....					
Heron.....					
Netley.....					
Orwell.....					
Speedy.....					
Tyrian.....					
Dapper.....	284	Wood	140 to 272	8	II 64-pdr.
Earnest.....					
Fervent.....					
Skylark.....					
Thrasher.....					
Whiting.....					
Ant.....					
Arrow.....					
Badger.....					
Blazer.....					
Bloodhound.....	254	Iron	168 to 268	9	I 10-inch.
Bonita.....					
Bulldog.....					
Bustard.....					
Cornet.....					
Cuckoo.....					
Fidget.....					
Gadfly.....					
Griper.....					
Hyena.....					
Kite.....					
Mastiff.....					
Pickle.....					
Pike.....					

ENGLISH UNARMORED FLEET—(CONTINUED.)

(NEW CRUISERS.)

TYPE AND NAME.	Displacement.	Construction Material.	Indicated Horse-power.	Maximum Speed.	BATTERY.	
	Tons.			Knots.		
2D CLASS GUN-BOATS.	} 254	Iron }	} 168 to 268	} 8	I 10-inch.	
						Pincher.....
						Scourge.....
						Snake.....
						Snap.....
	} 249	Wood	131	8	II 64-pdrs.	
						Hunter.....
						Plucky.....
196	Iron	224	I 9-inch.		
180	"	134	I 9-inch.		

INCONSTANT.

Iron frigate sheathed with wood and coppered. Straight bow, round stern. Rail cut back on each side of the bowsprit to permit bow-fire. Gun-deck battery composed of ten 9-inch rifles in broadside, the ports being very widely spaced. Long topgallant forecastle and flush aft. Spar-deck battery composed of six 7-inch rifles. One bow-gun under the fore-castle working in four ports (one each side ahead and one each side abeam), the gun being transported from one to another by turn-tables. One stern-gun working on turn-tables in three ports (one astern and one on each quarter). The remaining four guns are arranged as pivots, so that all may be used on one side if desirable. They secure in pairs amidships. The ports for these guns are cut in pairs forward and abaft the gun-deck ports. The strength of fire of this ship is: ahead, one 7-inch; abeam, six 7-inch, five 9-inch; astern, one 7-inch. The stability of this ship being originally deficient, part of her double bottom was filled with 180 tons of cement, thus reducing her estimated speed nearly one knot. Her coal supply permits steaming 2160 miles at a speed of ten knots. Greatest speed attained at sea for twenty-four consecutive hours, 15½ knots.

SHAH.

RALEIGH.

Iron frigates sheathed with wood and coppered. General type similar to the Inconstant. The gun-deck battery of the

Shah is a broadside one of sixteen 7-inch rifles and two 64-pdrs., the latter being just forward of the cabin bulkhead (separated from the main battery). The spar-deck battery consists of one

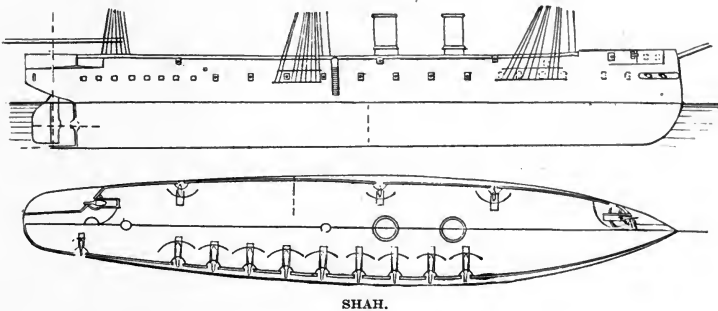

SHAH.

10-inch rifle under the topgallant forecastle, working in the same manner as the Inconstant's; one 10-inch rifle stern-gun working in two ports, the quarter-rail being recessed for the purpose, so as to get stern and beam fire; six 64-pdrs. in broadside (two forward and two abaft the gun-deck battery, and two abreast the after smoke-stack). The Raleigh's battery is similar to the Shah's in arrangement, but is smaller in number. (Fourteen guns on gun-deck; six on spar-deck.)

BOADICEA.

BACCHANTE.

EURYALUS.

Iron-sheathed frigates of the same general type as the above. The battery is all under cover; the broadside battery being entirely on the gun-deck, the bow-gun under the topgallant forecastle, and the stern-gun in the spar-deck cabin. The Boadicea has a straight stem, the other two ram bows. In order to permit the latter arrangement the wood sheathing was covered with zinc in place of copper, to allow of direct connection with the iron ram without danger of galvanic action.

ROVER.

ACTIVE.

VOLAGE.

First-class corvettes, iron sheathed with wood. Of the same general type as the Inconstant, except that the battery is all carried on the spar-deck. Strength of fire: Ahead—Rover and Active, one 7-inch; Volage, one 64-pdr. Abeam—Rover, two 7-inch, eight 64-pdrs.; Active, three 7-inch, two 64-pdrs.; Volage, ten 64-pdrs. Astern—Rover and Active, one 7-inch; Volage, one 64-pdr.

All other corvettes of the new type carry their batteries on

the spar-deck and are of the same general type, differing only in engines and boilers and the material of the hull.

CLEOPATRA CLASS (nine in number).

First-class steel corvettes, sheathed with wood. Bow and stern guns, 7-inch rifles; broadside, twelve 64-pdrs.; beam-fire, two 7-inch, six 64-pdrs.

AMETHYST CLASS (eleven in number).

First-class composite corvettes. Six of the number form a subdivision of the class, being of later build, having about 30 tons more displacement and carrying but twelve instead of fourteen 64-pdrs. The noticeable feature with regard to this class is the recession of the spar-deck rail forward and aft to

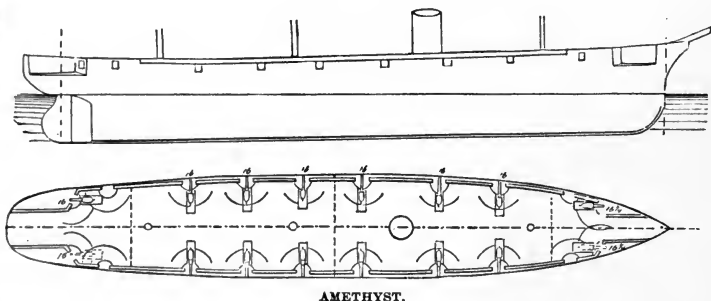

give clear bow and stern fire. Only one gun is used at either end, pivoting each side. In the case of the Amethyst class these guns are 64-pdrs., mounted on ordinary carriages. In the Cleopatra class and larger ships they are 7-inch guns, mounted on pivot carriages, which renders the working much heavier. The bow and stern guns are both under cover; the broadside guns are on the open spar-deck.

CORMORANT CLASS (twelve in number).

Second-class composite corvettes, carrying 7-inch bow and stern guns and 64-pdrs. in broadside.

ALBATROSS CLASS (six in number).

Third-class composite corvettes, carrying 64-pdr. bow and stern guns and 7-inch broadside. These vessels are bark rigged, and carry crews of one hundred and twenty men.

IRIS.

MERCURY.

Fast steel despatch and torpedo vessels. Their batteries consist of ten 64-pdrs. The boilers and engines take up the greater part of the space below. In addition to the battery each vessel carries four 80-foot Thorneycroft torpedo-boats fitted for launching Whitehead torpedoes. These launches are

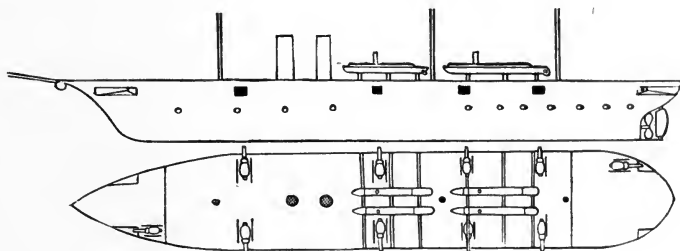

IRIS.

carried on a species of gallows-frame amidships, the frame being carried to the outer edge of the rail, so that the launch may be slid out over the side and lowered without trouble. In exterior appearance these vessels are not unlike fast mail packets.

MYRMIDON CLASS (nineteen in number).

First-class composite gun-boats, carrying for bow and stern guns 64-pdrs., and a single 7-inch centre pivoting rifle amidships. Twelve of these gun-boats form a subdivision of the

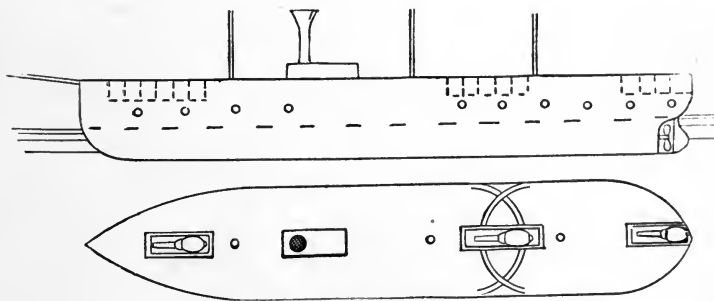

MYRMIDON.

class, having about 70 tons less displacement and carrying 40-pdr. bow and stern guns. They are bark rigged, carrying

crews of about 90 men, and have a mean draft of water of about 11 feet.

AVON CLASS (twenty-four in number).

First-class twin-screw gun-boats, carrying 20-pdrs. for bow and stern guns, and two 64-pdrs. amidships on pivot-carriages.

FIREBRAND CLASS (twenty-one in number).

Second-class single-screw composite gun-boats, carrying the same battery as the Avon class. Three-masted, square-rigged forward, lifting screws, crew of 60 men, and mean draft of water 9 feet. At a speed of six knots they burn about three tons of coal per twenty-four hours.

BRITOMART CLASS (sixteen in number).

Second-class wooden gun-boats of the old-fashioned type, carrying two 64-pdr. pivot-guns.

BLAZER CLASS (twenty-four in number).

Second-class iron gun-boats, carrying one 10-inch rifle. These vessels are little more than large launches, having a bow decked over with light plates. The gun is mounted on a platform, which itself is supported on heavy screws; these screws, being revolved by steam-power, permit the gun to be lowered down

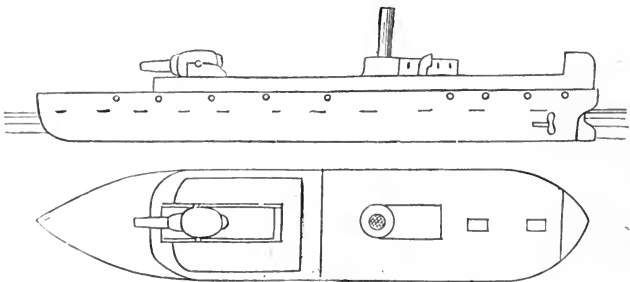

BLAZER.

into the hold when going to sea, or raised for fighting. The in-and-out tackles and ammunition gear are manipulated by a small capstan aft. These boats have double screws, and work up to a speed of 7 knots. The *Staunch*, which is the model from which these gun-boats were built, is smaller, and has a musket-proof shelter at the gun. The others have none.

DEE CLASS (twelve in number).

Second-class iron river gun-boats, of a peculiar design. These vessels have twin screws, and are provided with a rudder at each end, the bow-rudder, with its yoke and chains, being entirely unprotected. The hull proper is very low, the side curving sharply inboard above the water-line, almost in cigar shape, to such a degree that the dead-lights slope at an angle upward of about 40° . The deck-rail springs from the upper

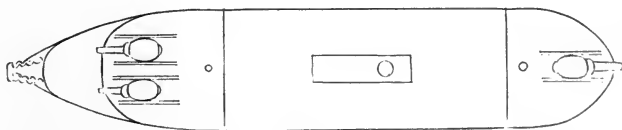
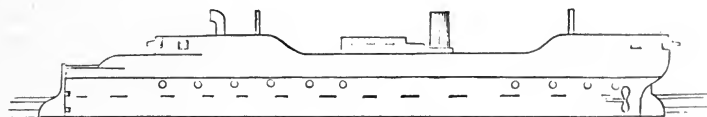

DEE.

part of this curve about two feet inside of the water-line, being waist high amidships and rising fore and aft into a curved fore-castle and poop musket-proof firing-cover for the guns. Amidships are a musket-proof pilot-house and engine-room. The battery consists of two 64-pdrs. at each end under cover, and firing from four ports each, two fore and aft and two abeam.

VESUVIUS.

Torpedo-boat. This craft, built for sudden attacks with torpedoes, is built very low in the water. The smoke-stack is bent horizontally, running along the deck. The furnace is intended to burn coke in order to suppress smoke. The steam-discharge pipes open under water. She is rigged for projecting Whitehead torpedoes. (See Torpedoes, Part III.)

LIGHTNING CLASS.

Fast torpedo-launches. (See Torpedoes.)

ENGLISH GENERAL-SERVICE FLEET.

(OLD-TYPE STEAM CRUISERS.)

TYPE AND NAME.		Displace- ment.	Construction Material.	Indicated Horse-power.	Maximum Speed.	Guns.
		Tons.			Knots.	
Ships of the Line.	Victoria	6,959	Wood	4,191	12.3	12
	Howe	6,557	"	4,524	13.2	12
	Duke of Wellington.....	6,071	"	1,999	9.9	25
	Duncan	5,724	"	2,836	13.2	31
	Royal Albert.....	5,637	"	1,805	8
	Donegal	5,481	"	3,103	11.2
	Anson	5,260	"	3,583	11.8	11
	Atlas	5,260	"	3,732	12	11
	Defiance	5,260	"	3,350	12
	Revenge	5,260	"	2,896	11.7
	Royal William.....	4,579	"	1,763	9.8
	St. George	4,579	"	1,730	10.6
	Albion.....	4,382	"	1,835	10.5
	Rodney	4,375	"	2,246	11.5	10
Lion.....	3,842	"	1,732	9.3	12	
Frigates.	Galatea	4,583	"	2,759	13.2	26
	Bristol	4,020	"	2,088	11.8	28
	Glasgow	4,020	"	2,020	12.4	28
	Newcastle.....	4,020	"	2,354	13.3	31
	Undaunted.....	4,020	"	2,261	12.7	31
	Immortalité.....	3,984	"	2,391	11.8	28
	Topaze	3,915	"	2,538	11.7	28
	Doris.....	3,803	"	3,005	12	24
	Aurora.....	3,582	"	1,576	10.1	28
	Narcissus	3,548	"	1,731	10.6	18
	Forte	3,456	"	1,539	9.2
	Endymion.....	3,197	"	1,620	9.4	22
	Corvettes.	Ariadne.....	4,583	"	3,350	13
Rattlesnake.....		2,431	"	1,628	11	17
Wolverine		2,431	"	1,549	11.2	17
Challenger.....		2,306	"	1,261	8.6	8
Thalia.....		2,216	"	1,597	10.1	8

ENGLISH GENERAL-SERVICE FLEET—(CONTINUED.)

(OLD-TYPE STEAM CRUISERS.)

TYPE AND NAME.	Displacement.	Construction Material.	Indicated Horse-power.	Maximum Speed.	Guns.	
	Tons.			Knots.		
Corvettes.	Juno	2,216	Wood	1,381	9.2	8
	Charybdis	2,187	"	1,472	11	17
	Pearl	2,187	"	1,390	11.3	17
	Scylla	2,187	"	1,376	10.7	17
	Druid	1,870	"	2,272	12.9	14
	Briton	1,870	"	2,149	13.2	14
	Thetis	1,870	"	2,275	13.4	14
	Blanche	1,755	"	2,158	13.6	12
	Danae	1,755	"	2,089	13.4	12
	Dido	1,755	"	2,518	13.7	12
	Eclipse	1,755	"	1,946	12.1	12
	Sirius	1,755	"	2,334	12.8	12
	Spartan	1,755	"	1,988	12.2	12
	Tenedos	1,755	"	2,032	12.7	12
Sloops.	Daphne	1,574	"	1,927	5
	Dryad	1,574	"	1,464	9
	Nymphe	1,574	"	2,172	9
	Vestal	1,574	"	2,154	9
	Cameleon	1,365	"	702	7
	Rinaldo	1,365	"	752	7
	Alert	1,331	"	312	4
	Fawn	1,045	"	434	4
	Rapid	913	"	460	3
	Rosario	913	"	436	3
	Assistance	2,515	Iron	1,442	2
Troop-ships.	Dromedary	1,800	"	1,640	2
	Humber	2,000	"	1,700	2
	Himalaya	4,490	"	2,609	3
	Orontes	5,600	"	2,569	2
	Simoon	3,302	"	1,576	2
	Tamar	4,857	"	2,171	2
Crocodile	6,211	"	4,044	3	

ENGLISH GENERAL-SERVICE FLEET—(CONTINUED.)

(OLD-TYPE STEAM CRUISERS.)

TYPE AND NAME.		Displacement.	Construction Material.	Indicated Horse-power.	Maximum Speed.	Guns.
		Tons.			Knots.	
Troop-ships.	Euphrates	6,211	Iron	3,900	3
	Jumna	6,211	"	3,040	3
	Malabar	6,211	"	4,893	3
	Serapis.....	6,211	"	4,030	3
Supply-ships.	Fox	1,670	Wood	764	2
	Discovery	1,247	"	365	2
	Industry	1,126	Iron	279	2
	Supply	1,126	"	265	2
	Wye	1,161	"	629	2
Paddle-wheel Dispatch Steamers.	Helicon	985	Wood	1,610	15	2
	Lively	985	"	1,757	2
	Salamis	985	"	1,440	14	2
	Vigilant.....	985	"	1,815	2
Yachts.	Osborne	1,800	"	3,363	2
	Victoria and Albert.....	2,470	"	2,980	2
	Alberta	370	"	1,208	
	Elfin	93	"	181	
	Enchantress	985	"	1,318	1
Surveying Vessels.	Nassau.....	877	"	755	4
	Porcupine.....	556	"	285	1
	Sylvia.....	877	"	689	4
Torpedo Depot-ship.	Hecla	Iron	6

Paddle-wheel Frigate Valorous. Corvettes Argus, Barracouta, Basilisk, Buzzard, Salamander, Sphynx, Spiteful.

9 Paddle-steamers. 33 Harbor-tugs. 177 Hulks used as school, depot, guard, hospital, coal, and store ships.

Iron-clad Hulks Caledonia, Enterprise, Favorite, Lord Clyde, Ocean, Prince Consort, Royal Alfred, Royal Oak, Royal Sovereign.

The General Service fleet, with the exception of the Transports and Yachts, belong to the old-fashioned types of steam cruisers. They are, however, constantly in commission as cruising vessels on home and foreign stations.

FRANCE.

ARMORED FLEET.

FRANCE.

TYPE AND NAME.	Length between Perpendiculars.		Breadth of Beam.		Maximum Draft.		Displacement.		Construction Material.		Greatest Thickness of Armor.		Least Thickness of Armor.		Backing.		Horse-power.		Maximum Speed.		BATTERY.			
	Ft. in.	in.	Ft. in.	in.	Ft. in.	in.	Tons.	In.	In.	In.	In.	In.	In.	In.	Knots.	Knots.	In.	In.	Knots.	Knots.	In.	In.		
Masted Iron-plate Ships.	319	5	66	11	26	10,315	Iron	23	In.	23	Armored only at water-line and turrets	14	14	6,000	6,000	14	14	6,000	6,000	14	14	IV 13¼-inch, XIV 5½-inch.	IV 13¼-inch, XIV 5½-inch.	
	285	7	57	3	24	5,785	"	11	11	11	"	14	14	4,100	4,100	14	14	6,000	6,000	14	14	IV 9¼-inch, I 7½-inch, VI 5½-inch.	IV 9¼-inch, I 7½-inch, VI 5½-inch.	
	371	7	66	5	24	9,630	"	16.5	16.5	16.5	13.7	13.7	12.6	12.6	6,000	6,000	14	14	6,000	6,000	14	14	VI 12¼-inch, VIII 5½-inch.	VI 12¼-inch, VIII 5½-inch.
	371	7	66	5	24	9,630	"	16.5	16.5	16.5	13.7	13.7	12.6	12.6	6,000	6,000	14	14	6,000	6,000	14	14	VI " VIII "	VI " VIII "
	330	7	66	5	24	8,658	"	15.3	15.3	15.3	8.7	8.7	15	15	6,000	6,000	14.5	14.5	6,000	6,000	14.5	14.5	VIII 10¾-inch, VIII "	VIII 10¾-inch, VIII "
	314	1	57	3	27	8,167	Wood	8.7	8.7	8.7	6	6	34.5	34.5	4,800	4,800	14	14	4,800	4,800	14	14	VIII " I 9¼-inch, VI 5½-inch.	VIII " I 9¼-inch, VI 5½-inch.
	314	1	57	3	27	8,164	"	8.7	8.7	8.7	6	6	34	34	4,800	4,800	14	14	4,800	4,800	14	14	VIII " I " VI "	VIII " I " VI "
	314	1	57	3	27	8,164	"	9.8	9.8	9.8	6	6	15	15	3,800	3,800	13.3	13.3	3,800	3,800	13.3	13.3	VIII " VIII 5½-inch.	VIII " VIII 5½-inch.
	314	1	57	3	27	8,269	"	8.7	8.7	8.7	6	6	34.5	34.5	3,800	3,800	13.8	13.8	3,800	3,800	13.8	13.8	VI " V 9¼-inch.	VI " V 9¼-inch.
	282	10	57	7	29	7,360	"	7.8	7.8	7.8	6	6	32.3	32.3	3,878	3,878	13.8	13.8	3,878	3,878	13.8	13.8	II 5½-inch, X 4¾-inch.	II 5½-inch, X 4¾-inch.
282	10	57	7	29	7,360	"	7.8	7.8	7.8	6	6	32.3	32.3	3,673	3,673	13.5	13.5	3,673	3,673	13.5	13.5	IV 10¾-inch, IV 9¼-inch, VI 4¾-inch.	IV 10¾-inch, IV 9¼-inch, VI 4¾-inch.	
282	10	57	7	29	7,360	"	7.8	7.8	7.8	6	6	32.3	32.3	4,181	4,181	14.1	14.1	4,181	4,181	14.1	14.1	IV 10¾-inch, IV 9¼-inch, VI 4¾-inch.	IV 10¾-inch, IV 9¼-inch, VI 4¾-inch.	

Masted Iron-plate Ships.

Casemate Ships.

FRENCH ARMORED FLEET—(CONTINUED.)

TYPE AND NAME.	Length between Perpendiculars.		Breadth of Beam.		Maximum Draft.		Displacement.	Construction Material.	Greatest thickness of Armor.		Least thickness of Armor.	Backing.	Indicated Horse-power.	Maximum Speed.	BATTERY.
	Ft. in.	Ft. in.	Ft. in.	Ft. in.	Tons.	In.			In.	In.					
(Gloire.....)	252	3	55	9	27	10	5,530	Wood	4.7	4.7	3	26	2,537	12.8	VI 9¼-inch, IV 7½-inch.
Couronne.....	260		54	3	25		5,813	Iron	4.7	4.7	3	15	2,820	12.2	
Flandre.....	258	10	55	9	26	10	5,725	Wood	6	6	4	26	3,540	14.3	
Provence.....	258	10	55	9	26	10	5,700	"	6	6	4	26	3,500	13.9	
Herôine.....	258	10	55	9	26	10	5,700	Iron	6	6	4	26	3,143	12.1	
Gauloise.....	258	10	55	9	26	10	5,610	Wood	6	6	4	26	3,500	13.9	
Guyenne.....	258	10	55	9	26	10	5,610	"	6	6	4	26	3,500	13.9	
Magnanime.....	258	10	55	9	26	10	5,610	"	6	6	4	26	3,500	13.9	
Savoie.....	258	10	55	9	26	10	5,610	"	6	6	4	26	3,500	13.9	
Revanche.....	258	10	55	9	26	10	5,610	"	6	6	4	26	3,500	13.3	
Surveillante.....	258	10	55	9	26	10	5,610	"	6	6	4	26	3,500	13.3	
Valeureuse.....	258	10	55	9	26	10	5,610	"	6	6	4	26	3,500	13.3	

Armored Frigates.

Corvettes.	Bayard.....	230	45 9	21	5,785	Iron	9.85	7	15	3,200	14	VI 9¼-inch, I 7½-inch, VI 5½-inch.	
	Turenne.....	230	45 9	21	5,785	"	9.85	7	15	3,200	14		
	Vauban.....	230	45 9	21	5,785	"	9.85	7	15	3,200	14		
Casemated Corvettes.	La Gallissonniere.....	230	45 9	21	4,480	Wood	6	4.7	26	2,376	13	VI 9¼-inch, I 7¼-inch, II 4¾-inch.	
	Victorieuse.....	230	45 9	21	4,147	"	6	4.7	26	2,400	13.2	VI " I " VI 5½-inch.	
	Triomphante.....	230	45 9	21	4,147	"	6	4.7	26	2,400	13.2	VI " I " II "	
	Alma.....	230	46 3	23 9	3,665	"	6	4.7	26	1,897	11.8	VI 7½-inch, IV 4¾-inch.	
	Bellequeuse.....	230	46 3	23 9	3,410	"	6	4.7	26	1,233	11.8		
	Jeanne d'Arc.....	230	46 3	23 9	3,371	"	6	4.7	26	1,900	12.3		
	Thetis.....	230	46 3	23 9	3,371	"	6	4.7	26	1,900	12.3		
	Armide.....	230	46 3	23 9	3,371	"	6	4.7	26	1,900	12		
	Atalante.....	230	46 3	23 9	3,371	"	6	4.7	26	1,900	12		
	Montcalm.....	230	46 3	23 9	3,371	"	6	4.7	26	1,900	12		
Reine Blanche.....	230	46 3	23 9	3,371	"	6	4.7	26	1,900	12			
Coast-defence Ships.	Tonnerre.....	241 6	57 9	21 4	5,495	Iron	14	8.6	15.7	3,500	13.5		II 12½-inch.
	Fulminant.....	241 6	57 9	21 4	5,495	"	14	8.6	15.7	3,500	13.5		
	Furieux.....	241 6	57 9	21 4	5,495	"	14	8.6	15.7	3,500	13.5		
	Calman.....	"	VI 12½-inch.	
	Indomptable.....	"	II 12½-inch.	
	Terrible.....	"		
2d Class Rams.	Tempete.....	241 6	57 9	16 9	4,452	"	13.8	9.85	15.7	1,500	10	II 9¼-inch.	
	Tonnant.....	241 6	57 9	16 9	4,452	"	13.8	9.85	15.7	1,500	10		
	Vengeur.....	241 6	57 9	16 9	4,452	"	13.8	9.85	15.7	1,500	10		

FRENCH ARMORED FLEET—(CONTINUED.)

TYPE AND NAME.	Length between Perpendiculars.		Breadth of Beam.		Maximum Draft.		Displacement.		Construction Material.		Greatest thickness of Armor.		Least thickness of Armor.		Backing.		Indicated Horse-power.		Maximum Speed.		BATTERY.	
	Ft. in.	Ft. in.	Ft. in.	Ft. in.	Ft. in.	Tons.	Tons.	In.	In.	In.	In.	In.	In.	Knots.	Knots.	Horse-power.	Horse-power.	Horse-power.	Horse-power.			
Coast-defence Ships. Molt- torf	Tigre.....	216 6	53 1	19 7½	3,313	Wood	8.6	6.3	31.5	1,800	12	II 9¼-inch.	I 12½-inch.	II 9¼-inch.	II 9¼-inch.	II 9¼-inch.	II 9¼-inch.	II 9¼-inch.	II 9¼-inch.	II 9¼-inch.	II 9¼-inch.	
	Belier.....	216 6	53 1	19 7½	3,313	"	8.6	6.3	31.5	1,800	12											
	Bouledogue.....	216 6	53 1	19 7½	3,313	"	8.6	6.3	31.5	1,800	12											
	Cerberé.....	216 6	53 1	19 7½	3,313	"	8.6	6.3	31.5	1,800	12											
	Taureau.....	216 6	53 1	19 7½	3,313	"	6	4.3	26	1,805	11.9											
	Onondaga.....	238 7	51 2	12 7½	2,551	Iron	6.7	4	11.8	613	7											
Armored Batteries.	Embuscade.....	129 7	51 10	10 10	1,422	"	5.5	4.3	15.7	440	8.5	IV 7½-inch.	IV 7½-inch.	IV 7½-inch.	IV 7½-inch.	IV 7½-inch.	IV 7½-inch.	IV 7½-inch.	IV 7½-inch.	IV 7½-inch.	IV 7½-inch.	
	Protectrice.....	129 7	51 10	10 10	1,422	"	5.5	4.3	15.7	440	8.5											
	Imprenable.....	129 7	51 10	10 10	1,422	"	5.5	4.3	15.7	440	8.5											
	Refuge.....	129 7	51 10	10 10	1,422	"	5.5	4.3	15.7	440	8.5											
Armored Batteries.	Implacable.....	144 4	48 5	8 8	1,388	"	4.7	4.3	15.7	490	6.7	III 9¼-inch.	III 9¼-inch.	III 9¼-inch.	III 9¼-inch.	III 9¼-inch.	III 9¼-inch.	III 9¼-inch.	III 9¼-inch.	III 9¼-inch.	III 9¼-inch.	III 9¼-inch.
	Opiniatre.....	144 4	48 5	8 8	1,388	"	4.7	4.3	15.7	490	6.7											
	Nos. 8, 9, 10, 11.....	88 7	29 6	5 7	280	"	3.1	3.1	13.8	100	5.3											

AMIRAL DUPERRE.

DUGUESCLIN.

Armored belt and four barbette turrets. Ram bow and overhanging dome stern. The armor-belt covers the water-line to the height of the main-deck beams, coming below the point of the ram and covering the steering-gear. The barbette turrets are arranged one on each side, abreast the forward smoke-stack, having an overhang of nearly half its diameter, so as to give clear fore-and-aft fire. The other two

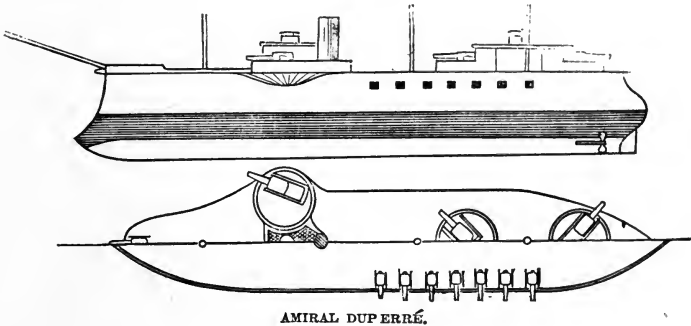

AMIRAL DUPERRÉ.

turrets are amidships, before and abaft the mizzen-mast. There are two armored pilot-houses on the Duperré, one abreast the forward turrets and one between the after ones; the Duguesclin has but one, forward. The gun-deck battery is composed of light rifled guns, unprotected. The deck plating of these ships is three inches in thickness (one inch steel over two inches of iron). A bow-gun works in a single port under the topgallant forecastle.

DEVASTATION.

FOUDROYANT.

REDOUBTABLE.

Armored belt and redoubt. Ram bow and dome stern. The belt of the Redoubtable encircles the water-line to the height of the main-deck beams, curving down forward over the point of the ram; that of the other two ships stops short of the curve of the counter in an armored bulkhead, the lower edge being carried on by an armored deck to protect the steering-gear. The sides forward and abaft the redoubt are given a rank tumble home, the redoubt rising straight to the spar-deck, thus giving clear fore-and-aft and beam fire from the main-deck battery. A heavy gun is mounted in barbette on top of the redoubt, each side, having a clear firing angle of 180° ; the gun-slide alone is protected by armor, while a mus-

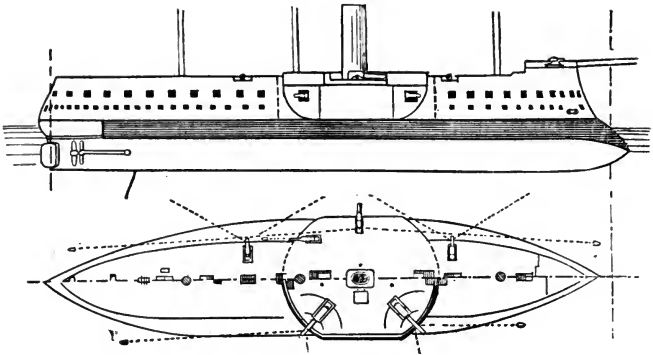

DEVASTATION.

ket-proof shield is mounted on the forward part of the slide, as protection to the crew. On the spar-deck is carried a battery of light rifles in broadside.

TRIDENT.

FRIEDLAND.

Armored belt and casemate. Ram bow and dome stern. The belt encircles the water-line to the height of the main-deck beams. The casemate rises to the height of the spar-deck beams. At the forward end of the casemate, on each side, a barbette unarmored half-turret is built, being simply a

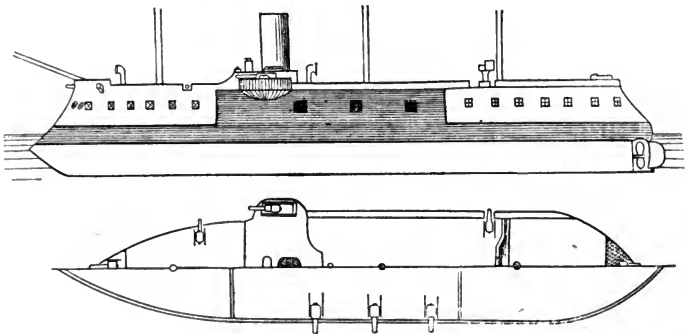

TRIDENT.

projecting shelf for mounting a heavy gun. The sides from the main-deck up forward are given a sharp tumble home to permit clear forward fire; while aft the spar-deck rail is placed inboard about three feet, leaving a clear fire aft, giving the part of the spar-deck outside the rail the appearance of a

continuous channel-piece. The turret guns are only protected by a light musket-proof shelter, rising above the slide. There is a light battery of broadside rifles on the spar-deck, a bow-gun working in one port under the fore-castle, and a similar stern-gun. There is no forward or after fire from the main-deck battery.

COLBERT.

Of the same type as the Friedland, except that in place of the barbette half-turrets there are armored breastworks for

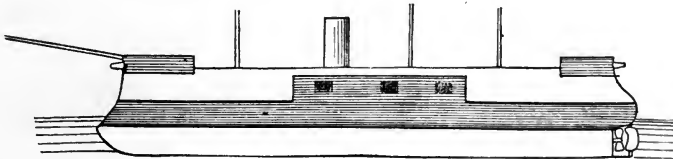

COLBERT.

the protection of a heavy bow and a heavy stern gun on the spar-deck.

RICHELIEU.

MARENGO.

OCEAN.

SUFFREN.

Armored belt and casemate, with four armored barbette turrets. Ram bow, straight stern. The belt encircles the

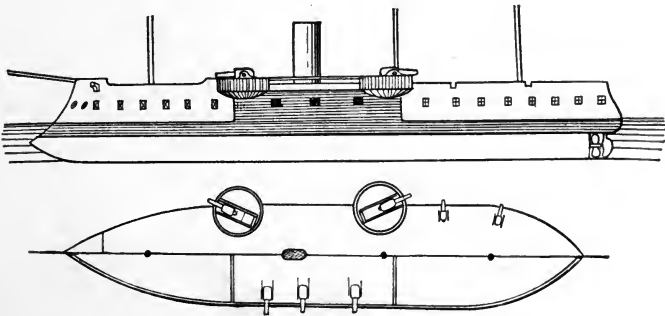

SUFFREN.

water-line, coming to but not covering the ram, which is a solid bronze casting. The barbette turrets are just over the corners of the casemate, projecting nearly half their diameter clear of the side for fore-and-aft fire. The side is not broken in or given a tumble home, as the muzzles of the turret guns are above the spar-deck rail. The Richelieu has twin screws,

the others single ones. There is no fore-and-aft fire from the casemate. Light spar-deck broadside battery. Armored commander's lookout.

BAYARD.	TURENNE.	LA GALLISSONNIERE.
TRIOMPHANTE.	VICTORIEUSE.	VAUBAN.

Second-rate sea-going iron-clads. Armored belt and casemate and two barbette turrets. The belt encircles the water-line to the height of the main-deck beams, the casemate carry-

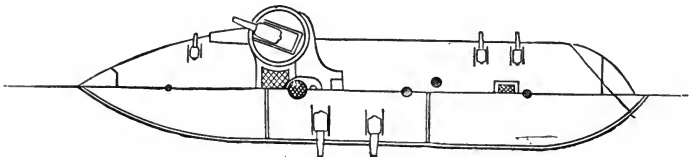
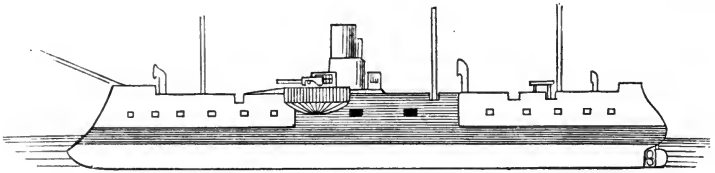

VICTORIEUSE.

ing the armor to the spar-deck. The barbette turrets are over the forward corners of the casemate. Ram bow and dome stern. Light spar-deck broadside battery. Bow-gun working in a single port under the forecastle.

GLOIRE.	COURONNE.	FLANDRE.	PROVENCE.
HEROINE	GAULOISE.	GUYENNE.	MAGNANIME.
SAVOIE.	REVANCHE.	SURVEILLANTE.	VALEUREUSE.

Broadside iron-clad frigates, completely armored. These vessels belong to the earliest type, and, with the exception of

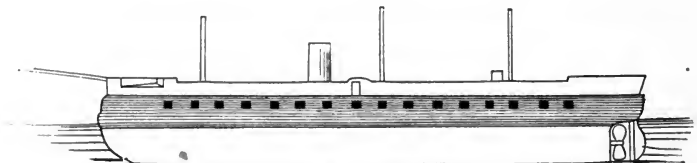

LA GLOIRE.

the Couronne and Heroine, they have wooden hulls. The armor extends from about three feet below the water-line to

the spar-deck beams. Armored conning towers are placed abaft the main-mast. Originally built for a large battery of light smooth-bores, the height of the main-deck prevents the full outfit of a heavy battery.

BELLIQUEUSE.	ALMA.	JEANNE D'ARC.	THETIS.
ARMIDE.	ATALANTE.	MONTCALM.	REINE BLANCHE.

Second-class cruising iron-clads. Armor belt and casemate, and four barbette turrets. The belt comes to the main-deck beams all around, the casemate carrying it up to the spar-deck.

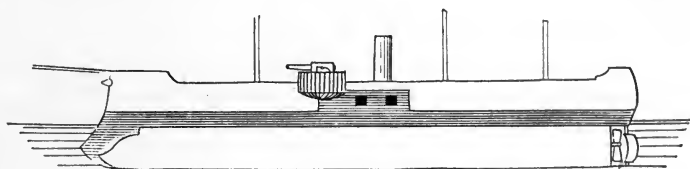

JEANNE D'ARC.

The turrets are at the corners of the casemates. In some of these vessels the after turrets were left off, it being found that the hull was overweighted when it was attempted to put heavier guns aboard than the ships were originally intended to carry.

TONNERE.	FULMINANT.	FURIEUX.
TEMPETE.	TONNANT.	VENGEUR.

Single-turreted, casemated monitors for coast defence. These vessels are heavily armored at the water-line; the single

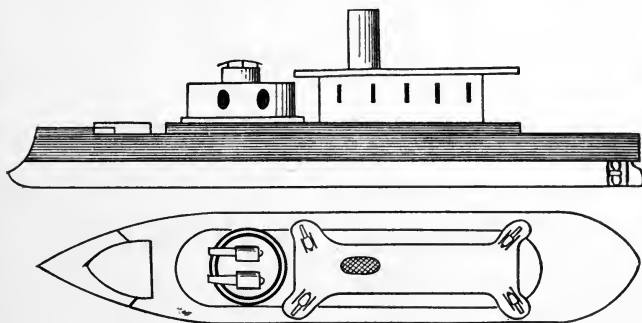

TONNERRE.

turret is very large, in order to bring the two guns in it well

apart, to gain clear fire aft on each side of the superstructure. This turret is on the forward third of the hull, and it, as well as the superstructure aft, is surrounded by a breastwork that does not come out to the side. On top of the turret is a barrette commander's lookout. Forward the deck rises into a short forecabin, just abaft of which is an armored casemate giving ingress into the crew's quarters. The superstructure abaft the turret is musket-proof, of a width just sufficient to permit the guns to get stern-fire. The upper part expands into a flying deck, with a low musket-proof shield, and corner stands for Hotchkiss machine-guns.

TIGRE.

BELIER.

CERBERE.

BOULEDOGUE.

Monitor rams. These vessels have a low freeboard, the single turret being on the forward third of the hull, surrounded by a casemate, which also covers the lower part of the smokestack. A superstructure rises forward and aft of the turret and is semi-cylindrical, curving at the ends in such a manner as to give no foothold on any part. The turret is surmounted by a barrette lookout. The hulls are of wood and heavily strengthened at the ram. Double screws.

TAUREAU.

Similar to the above, with the exception that the turret is

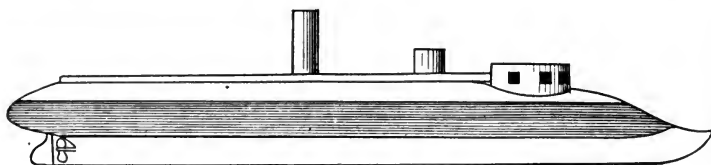

TAUREAU.

fixed and has four ports for bow and beam fire.

ONONDAGA.

Double-turreted American monitor; laminated plating, low freeboard, no casemate.

ROCHAMBEAU.

Casemated iron-clad (late Dunderberg). Ram bow, low

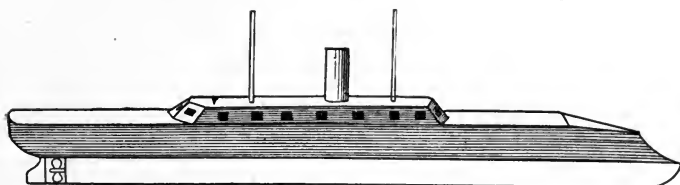

ROCHAMBEAU.

freeboard, and rectangular casemate, with sloping sides giving fore-and-aft and beam fire.

EMBUSCADE.
REFUGE.

PROTECTRICE.
IMPLACABLE.

IMPRENABLE.
OPINIATRE.

Armored floating batteries. Low freeboard forward and

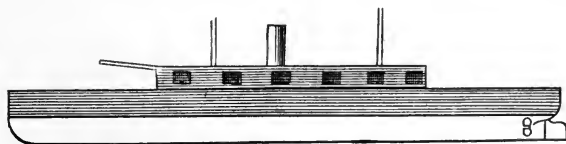

EMBUSCADE.

abaft, with rectangular casemates having perpendicular sides, and giving fore-and-aft and beam fire. Light draft.

CAIMAN.

INDOMPTABLE.

TERRIBLE.

Coast-defence vessels; type not known, but presumably citadel-ships of a displacement not less than 12,000 tons. The battery of this type is six $13\frac{1}{4}$ -inch guns. They are evidently intended as more powerful vessels than either the Inflexible or Duilio.

FRENCH UNARMORED FLEET.

(RAPID CRUISERS.)

TYPE AND NAME.	Length between Perpendiculars.		Breadth of Beam.		Mean Draft.		Displacement. Tons.	Construction Ma- terial.	Indicated Horse- power.	Maximum Speed. Knots.	Date of Launch.		BATTERY.
	Ft. in.	Ft. in.	Ft. in.	Ft. in.	Year	Building							
Duquesne.....	326	6 50	22	7	5,345	Iron sheathed	6,589	17	1876	VII 7½-inch, XIV 5½-inch.			
Tourville.....	326	6 50	22	7	5,345	"	6,589	17	1877	VII " XIV "			
Duguay Trouin.....	280	8 42	16	11	3,070	"	3,740	16	1877	V " V "			
Villars.....	249	3 37	15	11	2,231	Wood	2,730	15	Building				
Forfait.....	249	3 37	15	11	2,231	"	2,730	15	"				
Magon.....	249	3 37	15	11	2,231	"	2,730	15	"				
Roland.....	249	3 37	15	11	2,231	"	2,730	15	"				
La Perouse.....	262	5 37	17		2,900	"	2,730	15	"	VI 6½-inch, IX 5½-inch.			
D'Estaing.....	262	5 37	17		2,900	"	2,730	15	"				

1st Class
Cruisers.2d Class
Cruisers.

2d Class Cruisers	Mongé.....	202 5	37 5	17	2,200	Wood	2,790	15	Building	VI 6½-inch, IX 5½-inch.		
	Nielly.....	202 5	37 5	17	2,200	"	2,790	15	"			
	" * * *	202 5	37 5	17	2,200	"	2,790	15	"			
	" * * * *	202 5	37 5	17	2,200	"	2,790	15	"			
2d Class Cruisers	Infernet	245 8	35 9	12 5	1,865	"	1,784	14.4	1869	I 6½-inch, VIII 5½-inch.		
	Champlain	245 8	35 9	12 5	1,865	"	1,784	14.4	1872			
	Laclocherie	245 8	35 9	12 5	1,865	"	1,784	14.4	1872			
	Du Petit Thouars	245 8	35 9	12 5	1,865	"	1,784	14.4	1875			
	Sané.....	1,900	"	1,967	15	1867			
	Seignelay	1,900	"	1,900	14.7	1875			
	Fabert.....	1,900	"	1,900	14.7	1875			
	3d Class Cruisers	Eclairer.....	236 2	35 5	14 8	1,610	Composite	1,900	15		1876	VIII 5½-inch.
		Rigaut de Genouilly.....	236 2	35 5	14 8	1,610	"	1,900	15		1877	
		Bisson.....	200	28 5	11	833	"	850	12.2		1877	
2d Class Dispatch Vessels	Labourdonnais.....	200	28 5	11	833	"	850	12.2	1876	IV 5½-inch.		
	Hussard.....	200	28 5	11	833	"	850	12.2	1876			
	Lancier.....	200	28 5	11	833	"	850	12.2	1877			
	Chasseur	200	28 5	11	833	"	850	12.2	Building			
	Voltigeur	200	28 5	11	833	"	850	12.2	"			
	Bouvet.....	"		I 6½-inch, II 5½-inch, I 4¾-inch.	
	Parseval	850	"	850	12	1877			

FRENCH UNARMORED FLEET—(CONTINUED.)

TYPE AND NAME.		Displacement.	Date of Launch.	BATTERY.		
		Tons.	Year.			
1st Class Gun-boats.	Crocodile	452	I 7½-inch, II 4-inch.		
	Lionne			
	Lutin			
	Lynx			
	Milan			
	Vautour			
	Diligente	398	II 5½-inch.		
2d Class Gun-boats.	Chacal	295	II 5½-inch.		
	Etendard			
	Fanfare			
	Gladiateur			
	Hyene			
	Jaguar			
	Leopard			
	Oriflamme			
	Couleuvre		295		II 5½-inch.
	Décidée	
Frelon					
Pique					
	Surprise	177	} I 9¼-inch, I 4¾-inch.		
	Tactique	
	Epée	177	} I 9¼-inch, I 4¾-inch.		
	23 Gun-boats	177			
Transports.	Bievre	1,475	} II 5½-inch.		
	Oise	1,770			
	Caravans	2,868	1875			
	Ampère	Building			
	Annamite	5,340	1876			
	Mytho	5,340	Building			
	Shamrock	5,340	"			
	Tonquin	5,340	"			
	Allier	1,655	"		} IV 5½-inch.	
	Nievre	1,655	"			
Drac	1,655	"				
Saone	1,655	"				

DUQUESNE.

TOURVILLE.

Iron frigates, sheathed with wood and coppered. Strengthened bows for ramming, with heavy bronze rams. Three half-turrets or platforms on each side of the spar-deck, projecting clear of the side to give clear fore-and-aft fire. Bow-gun working in a single port under the forecastle. Pilot-house and chart-room on a bridge forward of the smoke-stacks. Boats carried on a gallows-frame between the smoke-stacks. Fine lines, heavy shoulder; the bow-frames are given a flare out from the main-deck up, to give a full forecastle for working

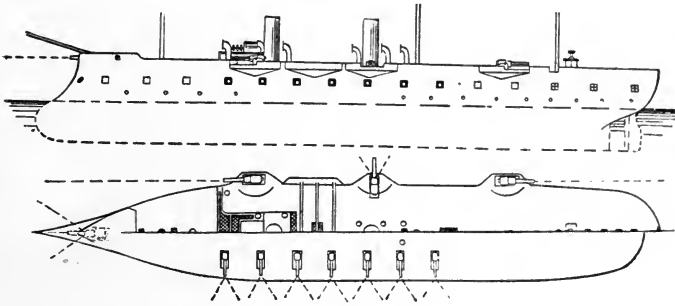

TOURVILLE.

the bow-gun. Single screw, full sail-power. Gun-deck, broadside battery, fourteen $5\frac{1}{2}$ -inch rifles. Spar-deck battery, seven $7\frac{1}{2}$ -inch rifles. Bow-fire, three $7\frac{1}{2}$ -inch; beam-fire, nine $5\frac{1}{2}$ -inch (two guns can be shifted on the gun-deck, so as to give nine for a broadside), three $7\frac{1}{2}$ -inch; stern-fire, two $7\frac{1}{2}$ -inch. Two sets of engines and boilers, placed one abaft the other for protection. Between the forward turrets on the spar-deck are the wash-rooms and water-closets, giving the appearance of a fourth half-turret. Maximum speed at sea for 24 hours, $16\frac{1}{2}$ knots.

DUGUAY TROUIN.

Iron corvette, sheathed with wood and coppered. Strengthened bow for ramming, with heavy bronze ram. Four half-turrets, similar to those of the Tourville. Bow-gun working under the forecastle in a single port. Single screw, full sail-

power. All the battery carried on the spar-deck, leaving a clear, roomy main-deck. Stern-gun mounted in barbette on a

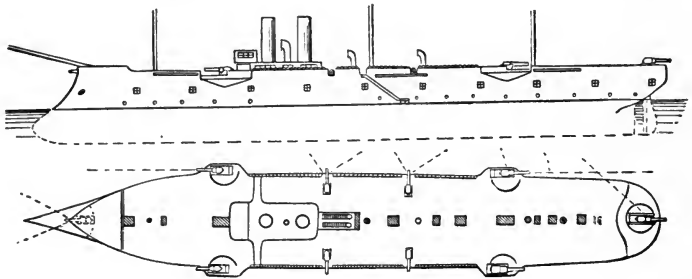

DUGUAY TROUIN.

centre-pivot carriage. Bow-fire, two $7\frac{1}{4}$ -inch, one $5\frac{1}{2}$ -inch; beam-fire, two $7\frac{1}{4}$ -inch, three $5\frac{1}{2}$ -inch; stern fire, two $7\frac{1}{4}$ -inch, one $5\frac{1}{2}$ -inch.

VILLARS CLASS (seventeen in number).

Second-class wooden corvettes, with strengthened ram bow. Two light bow-guns firing through recessed ports, giving bow and beam fire. (In some cases the guns are on the fore-

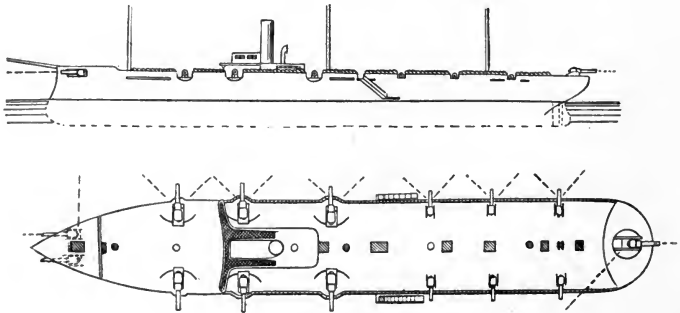

VILLARS.

castle, in others underneath.) Stern-gun mounted on a centre-pivot carriage in barbette. Midship guns of heavy calibre, the deck being carried out slightly, to give them an extreme firing angle.

ECLAIREUR CLASS (two in number).

Third-class composite corvettes, with strengthened ram

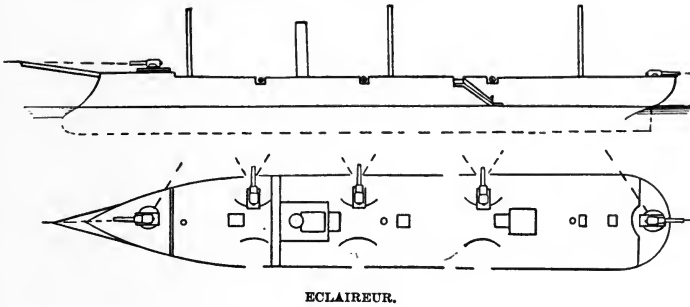

bow. Bow pivot-gun mounted on the forecastle: stern-pivot in barbette; six guns in broadside.

LANCIER CLASS (eight in number).

Avisos, or fourth-class corvettes, composite, with strengthened ram bows. Four rifled-guns mounted on centre-pivot

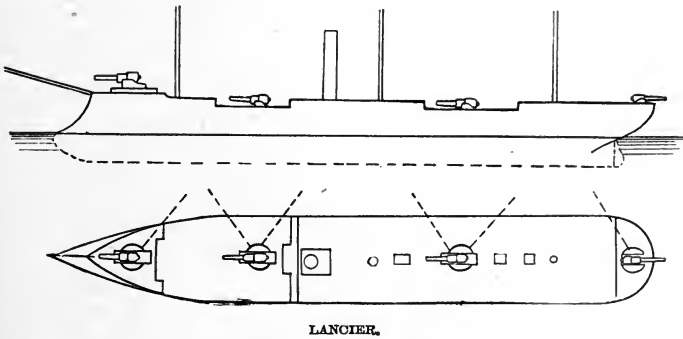

carriages in the midship line of the vessel. Drop-rail abreast the main-deck guns.

LYNX CLASS (seven in number).

First-class composite gun-boats, with strengthened ram bows. Light, centre-pivoting rifled bow and stern guns, and one heavy rifled, centre-pivot gun amidships firing in barbette.

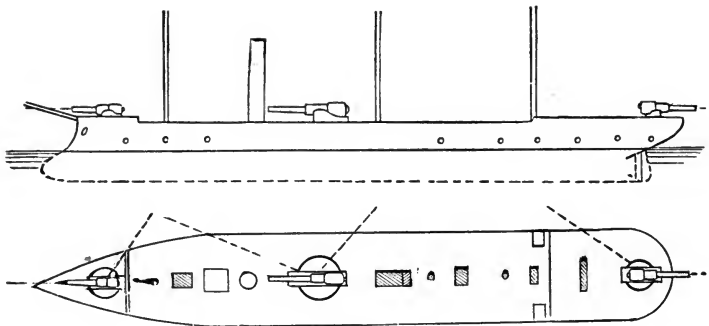

LYNX.

FARCY CLASS (twenty-seven in number).

Second-class iron gun-boats. These vessels are more nearly large launches, built with ram bows to give them good displacement. One heavy gun is mounted in the bow, the slope of

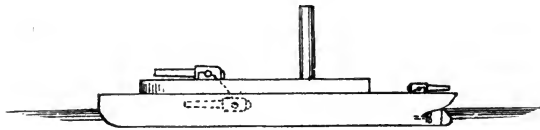

TROMBLON

the bow from the ram up being carried up to form a musket-proof shield, permitting the gun to fire through an embrasure.*

MYTHO CLASS (four in number).

First-class iron troop-ships, similar in general to the Eng-

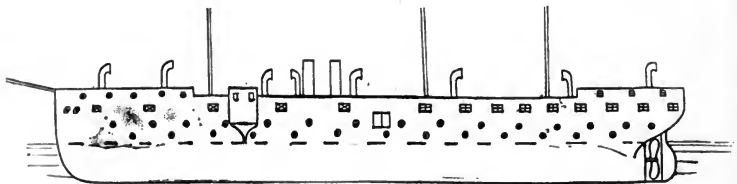

MYTHO.

lish troopers of the Serapis class. Capacity for berthing 1700 men with all the camp equipage.

* By increasing the displacement of this type thirty tons, an increase of speed of two knots has been obtained, a 4-inch stern-gun mounted, and the boats made perfectly seaworthy.

DRAC CLASS (four in number).

Light cavalry transports. These vessels are composite built and may serve either as transports or gun-boats, as they

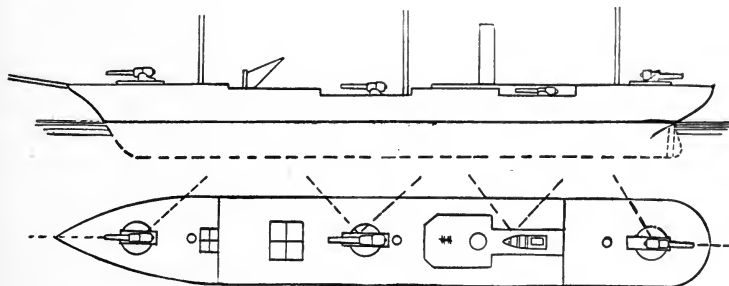

DRAC.

carry a battery of two light and two heavy centre-pivoting rifles. They are used for the transportation of cavalry horses, artillery, and stores.

BIEVRE CLASS (four in number).

Light, fast iron transports, similar in general to the Drac class.

FRENCH GENERAL-SERVICE FLEET.

(OLD-TYPE STEAM CRUISERS.)

TYPE AND NAME.		Displacement.	Indicated Horse-power.	Guns.	Construction Material.	Date of Launch.
		Tons.				Year.
Ships of the Line.	Souverain.....	5,115	25	Wood	1856
	Louis XIV.....	4,820	12	"	1854
	Ville de Bourdeaux.....	5,210	12	"	1860
	Ville de Lyon.....	5,210	12	"	1861
	Castiglione.....	5,500	12	"	1857
	Masséna.....	5,015	12	"	1860
	Fontenoy.....	3,934	12	"	1858
	Jean Bart.....	3,934	22	"	1854
Frigates.	Saint Louis.....	3,934	12	"	1854
	Pallas.....	3,560	1,330	34	"	1860
	Magicienne.....	3,375	1,310	32	"	1861
	Themis.....	3,375	1,310	18	"	1862
	Victoire.....	3,325	1,310	16	"	1861
	Flore.....	3,100	1,520	18	"	1867
	Clorinde.....	1,740	1,430	12	"	1865
	Corvettes.	Amorique.....	2,800	1,040	22	"
Minerve.....		2,700	1,530	22	"	1865
Venus.....		2,700	1,530	22	"	1864
Chateau Renaud.....		1,830	1,700	5	"	1866
Dupleix.....		1,780	1,050	10	"	1861
Decrès.....		1,770	1,480	6	"	1866
Desaix.....		1,640	1,780	6	"	1866
Laplace.....		1,590	700	10	"	1852
Cosmos.....		1,840	1,100	13	"	1861
D'Assas.....		1,920	740	16	"	1864
Sloops. (Aviso, 1st Class.)	Beautemps.....	1,270	1,050	6	"	1872
	Beaupré.....	1,270	1,050	6	"	1872
	Duchaffaut.....	1,289	1,050	3	"	1872
	Hugon.....	1,290	1,050	6	"	1872
	Kerguelen.....	1,280	1,050	6	"	1872
	Bourayne.....	1,260	960	6	"	1869
	Dayot.....	1,260	960	6	"	1869
Ducouëdic.....	1,260	960	6	"	1869	

FRENCH GENERAL-SERVICE FLEET—(CONTINUED).

(OLD-TYPE STEAM CRUISERS.)

TYPE AND NAME.	Displace-	Indicated	Guns.	Construction	Date of	
	ment.	Horse-power.				Material.
	Tons.			Wood	Year.	
Sloops (Avisos, 2d Class.)	Kersaint	1,270	960	6	Wood	1869
	Segond.....	1,260	960	6	"	1869
	Vaudreuil.....	1,280	1,050	6	"	1870
	D'Estrées.....	1,280	1,000	6	"	1867
	Volta ..	1,300	1,000	6	"	1867
	Hamelin	1,220	1,000	6	"	1866
	Limier	1,220	1,000	6	"	1866
	Talisman	1,310	800	6	"	1863
	Kleber	1,260	740	2	"	1856
	Forbin	1,250	870	4	"	1859
	Linois.....	830	720	6	"	1867
	Cassard	850	660	3	"	1859
Hirondelle.....	1,030	1,780	2	"	1870	
Despatch Vessels (Avisos, 2d Class.)	Renaud	840	490	4	"	1866
	Lamotte Piquet.....	720	420	4	"	1859
	Latouche Treville	720	390	4	"	1860
	Curieux	760	560	4	"	1859
	Surcouff	700	430	4	"	1858
	Bougainville.....	740	310	6	"	1859
	Bruat	700	490	4	"	1866
	Adonis	730	490	4	"	1868
	Guichen	700	460	2	"	1863
	Boursaint.....	750	610	3	"	1872
Corse	510	220	...	"	1842	
Transports.	Algesiras	5,600	2,100	4	"	1842
	Charlemagne.....	5,600	1,150	12	"	1851
	Intrépide	5,600	2,960	4	"	1864
	Ville de Paris.....	5,600	1,350	12	"	1850
	Guerrrière	3,200	1,350	4	"	1860
	Entreprenante.....	3,200	780	4	"	1858
	Dryade	3,200	540	4	"	1856
	Ceres	3,200	410	4	"	1857
	Danaë	3,250	540	4	"	1838
	Renommée.....	3,200	540	4	"	1847
Européen.....	2,350	1,200	2	Iron	

FRENCH GENERAL-SERVICE FLEET—(CONTINUED.)

(OLD-TYPE STEAM CRUISERS.)

TYPE AND NAME.	Displace- ment.	Indicated Horse-power.	Guns.	Construction Material.	Date of Launch.	
	Tons.				Year.	
Transports.	Japon	2,300	960	2	Wood	
	Aveyron.....	3,500	1,520	4	"	1864
	Correze.....	3,500	1,520	4	"	1868
	Creuze.....	3,500	1,520	2	"	1863
	Sarthe.....	3,500	1,520	2	"	1862
	Tarne.....	3,500	1,520	2	"	1863
	Orme.....	3,000	750	4	"	1862
	Var.....	3,000	750	4	"	1863
	Calvados.....	3,000	540	4	"	1856
	Finisterre.....	3,000	650	4	"	1859
	Garonne.....	3,000	650	4	"	1859
	Jura.....	3,000	650	4	"	1855
	Dordogne.....	2,400	370	4	"	1855
	Maine.....	2,400	370	4	"	1855
	Meuse.....	2,400	370	4	"	1855
	Rhin.....	2,400	560	4	"	1855
	Yonne.....	2,400	370	4	"	1856
	Seine.....	2,400	370	4	Iron
	Charente.....	2,000	280	4	"	1856
	Adour.....	1,800	250	2	"	1856
	Ariege.....	1,800	450	2	"	1865
	Isère.....	1,800	450	2	"	1865
	Moselle.....	1,970	390	2	"
	Vienne.....	1,800	370	2	Wood	1853
	Cher.....	1,400	610	6	"	1863
	Indre.....	1,400	610	6	"	1864
	Dives.....	1,682	670	2	"	1870
	Rance.....	1,682	670	6	"	1870
	Sendre.....	1,682	670	6	"	1872
	Vire.....	1,682	670	6	"	1868
	Loiret.....	1,200	210	3	"	1856

Paddle-wheel frigates Albatros, Magellan.

" corvettes Catinat, Coligny, Eumenide.

Four paddle-wheel gun-boats, 1st class, 700 to 800 tons, two to four guns.

Four " " " 2d " 700 tons, four guns.

Thirty screw tenders.

GERMANY.

ARMORED FLEET.

TYPE AND NAME.	Length between Perpendiculars.		Breadth of Beam.		Maximum Draft.		Displacement.		Construction Material.		Greatest thickness of Armor.		Least thickness of Armor.		Backing.		Indicated Horse-power.		Maximum Speed.		BATTERY.				
	Ft.	Ft.	Ft.	Ft.	Ft.	Tons.	In.	In.	In.	In.	In.	In.	In.	In.	Knots.	Horse-power.	Knots.	In.	In.	Knots.	Horse-power.				
Redoubt Frigates.	280	62	24	8	7,440	11½	6¼	10¼	8,000	14½	VIII 10¼-inch, I 8¼-inch.	8,000	14½	14	8,000	14½	10¼	8,000	14½	14	8,000	14½	VIII 10¼-inch, I 8¼-inch.		
																								Deutschland.....	62
Turret Frigates.	298	52	24	8	6,560	10½	5½	8½	5,400	14	IV 10¼-inch, II 6¾-inch.	5,400	14	5,400	14	8½	5,400	14	5,400	14	5,400	14	IV 10¼-inch, II 6¾-inch.		
																								Preussen.....	54
Casemate Frigates.	353	60	26	6	9,451	9¼	5½	9¼	8,000	14¾	XVIII 9¼-inch, V 8¼-inch.	8,000	14¾	8,000	14¾	9¼	8,000	14¾	14¾	8,000	14¾	8,000	14¾		
																								König Wilhelm.....	55
Kron Prinz.....	51	19	8	5,393	9	9	7¾	5,600	14	I 12-inch, IV 10½-inch	5,600	14	7¾	5,600	14	7¾	5,600	14	5,600	14	5,600	14	5,600		
																								Sachsen.....	51
Bairn.....	51	19	8	7,135	9	9	7¾	5,600	14	I 12-inch, IV 10½-inch	5,600	14	7¾	5,600	14	7¾	5,600	14	5,600	14	5,600	14	5,600		
																								Württemberg.....	51
Two others.....	213	51	19	8	7,135	9	9	7¾	5,600	14	I 12-inch, IV 10½-inch	5,600	14	5,600	14	7¾	5,600	14	5,600	14	5,600	14	5,600		
																								Barbette Corvettes.	213

GERMAN ARMORED FLEET—(CONTINUED.)

TYPE AND NAME.	Length between Perpendiculars.	Breadth of Beam.	Maximum Draft.	Displacement.	Construction Material.	Greatest thickness of Armor.	Least thickness of Armor.	Backing.	Indicated Horse-power.	Maximum Speed.	BATTERY.
	Ft.	Ft.	Ft. in.	Tons.		In.	In.	In.		Knots.	
Redoubt Corvette. Hansa	235	51	21 7	3,497	Wood	6¼	4	12½	3,000	12	VIII 8¼-inch.
Monitor. Arminius	197	36	13 7	1,538	"	4½	3	9	1,200	10½	IV "
Redoubt Ram. Prinz Adalbert	158	27	21 7	3,863	"	4½	3	12	1,000	9	I " II 6¾-inch.
Armored Gun-boats. Wespe	10 2	985	Iron	8	4	8	700	9	I 12-inch.
Viper	10 2	985	"	8	4	8	700	9	
Biene	10 2	985	"	8	4	8	700	9	
Mücke	10 2	985	"	8	4	8	700	9	
Scorpion	10 2	985	"	8	4	8	700	9	
Basilisk	10 2	985	"	8	4	8	700	9	
Four others	10 2	985	"	8	4	8	700	9	
River Monitors. Rhein	164	25	3 6	1½	1¼	8	80	6	
Mosel	164	25	3 6	1½	1¼	8	80	6	

KAISER.

DEUTSCHLAND.

Armored belt, redoubt, and stern casemate. Ram bow and straight stern. The belt encircles the water-line, coming up to the height of the main-deck beams abaft the redoubt, but forward of it reduced in height to not over three feet above the water-line, and having a heavy steel deck at the height of its upper edge. The belt does not cover the ram. The sides forward and abaft the redoubt are given a rank tumble home, while the redoubt is carried straight up to the spar-deck beams, opening fore-and-aft and beam fire from the angular ports,

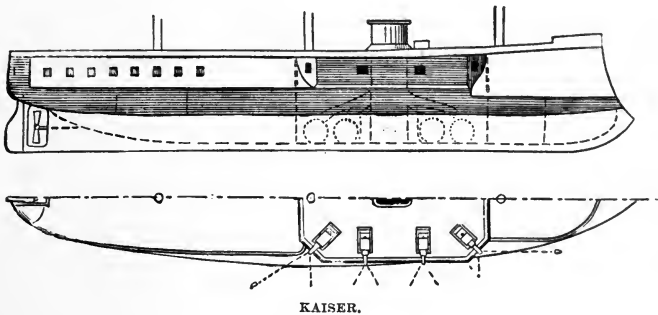

(vide Devastation, French). The stern casemate prevents raking from aft, and also protects a stern-gun working in a single port. The engines and boilers form two distinct sets, one abaft the other, the magazines and shell-lockers coming between them. The redoubt has an overhang clear of the side of $3\frac{1}{2}$ feet forward and $1\frac{1}{2}$ feet aft. There is no bow-gun, the bow-fire coming from the redoubt. The after-redoubt guns only fire to within 15° of right astern, the stern-gun filling out the dead-angle. Single screw, full sail-power.

FRIEDRICH DER GROSSE.

PREUSSEN.

Armored belt, breastwork, and two revolving turrets. These ships are built on the lines of the Monarch, although improved in detail. The belt encircles the water-line, but does not come as low down as the point of the ram. The breastwork surrounds the boilers and the bottoms of the turrets, but the engines are outside of and abaft it. The turrets are closer together than in the Monarch, and have no upper works to interfere with their fire. The dead-angles of the turret-guns

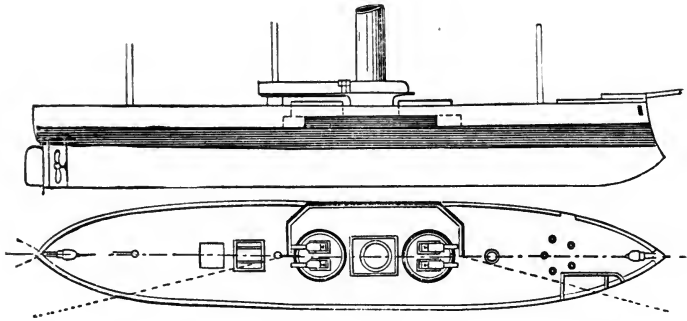

PREUSSEN.

are filled by a bow and stern gun working in single unprotected ports. These ships have single screws and about three-quarter sail-power.

KÖNIG WILHELM.

Armored belt and long, main-deck casemate, stern casemate, and two spar-deck redoubts. Ram bow and straight stern. The belt encircles the water-line, coming to the height of the main-deck beams aft, but somewhat lower forward of the casemate, that portion being covered by a steel deck. There is no forward or after fire from the casemate, the sides rising straight

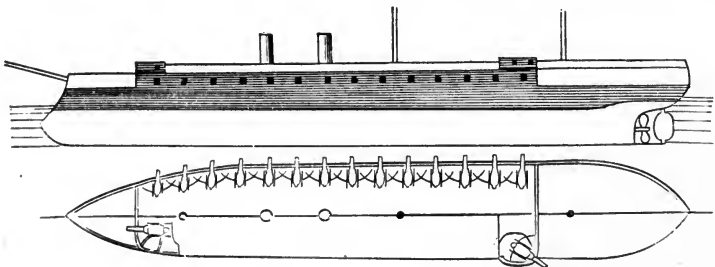

KÖNIG WILHELM.

up fore and aft. The ends of the casemate are protected from raking by armored bulkheads, rising to the spar-deck beams forward and abaft. The stern casemate protects a single gun working in one port. At the forward end of the main casemate, and rising clear of the upper deck, is a redoubt—or rather traverse, for it is unprotected at the rear—giving protection to two guns working each in two ports for fore-and-aft and beam

fire. At the after-end of the main casemate is a similar traverse, which has an overhang of several feet, its two guns working also each in two ports for stern and beam fire (vide Sultan, English). These traverses encumber the spar-deck for working the gear of the sails. Single screw and full sail-power.

FRIEDRICH KARL.

KRON PRINZ.

Armored belt and long casemate with bow redoubt. Ram bow and straight stern. The belt encircles the water-line to the height of the main-deck beams, coming down in a curve forward well over the ram. There is no fore-and-aft fire from the casemate, the ship being wall-sided. The bow redoubt

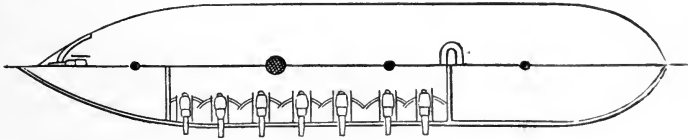
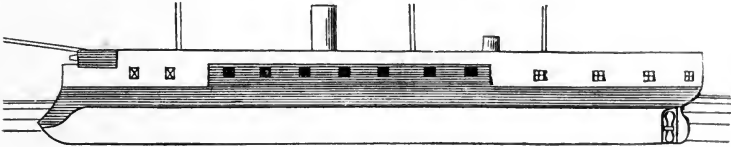

FRIEDRICH KARL.

cuts off the point of the bow above the spar-deck beams and protects a bow-gun working in a single port. There is a high, oval, armored pilot-house just abaft the main-mast. No stern-fire. Single screw and full sail-power.

SACHSEN.

BAIERN.

WÜRTEMBERG.

(Two others not yet named.)

Partial armored belt and two barbette casemates. Ram bow, round stern. Half sail-power (brig rigged). Four smoke-stacks. The belt forms a casemate for the boilers and engines, covering the middle third of the ship, the lower edge being prolonged in a heavy steel deck, which, aft, protects the steering-gear. This casemate rises to the spar-deck beams. At its after-end a high, rectangular barbette casemate rises well up above the spar-deck rail, giving clear fore-and-aft and beam

fire to its four guns. At the forward end of the casemate is an oval barbette turret (vide Temeraire, English) amidships, giving clear bow and beam fire to its single gun. These ships

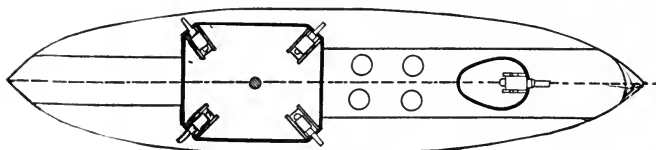
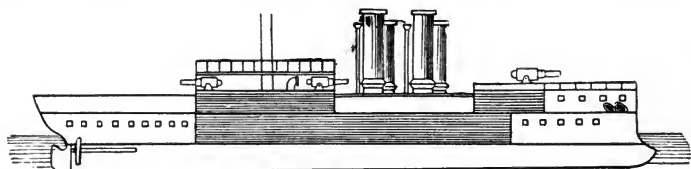

SACHSEN.

gain a nearly perfect all-around fire from the heaviest calibre guns, with a maximum thickness of armor. They combine great armor and battery strength with light draft and displacement.

HANSA.

Armored belt and double-decked redoubt. Swan-breasted bow strengthened for ramming, pointed stern, single screw,

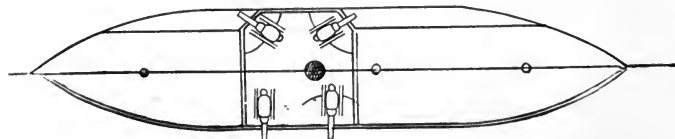
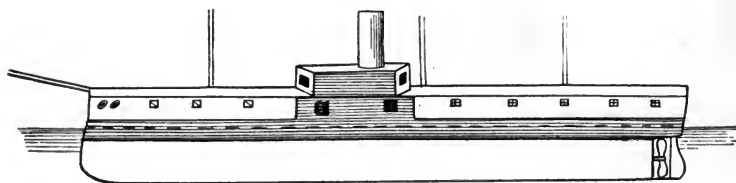

HANSA.

full sail-power. The belt encircles the water-line to the height of the main-deck. The main-deck redoubt is short and does not give fore-and-aft fire, the ship being wall-sided. The

upper-deck redoubt, rising a little above the spar-deck rail, is octagonal, to permit angular ports for fore-and-aft and beam fire. The spar-deck rail is carried inboard parallel to the keel to open the angular ports.

ARMINIUS.

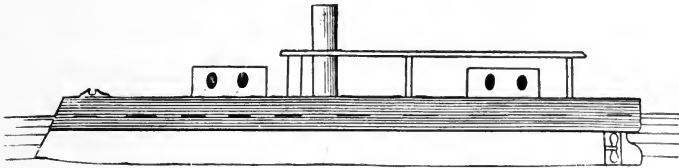

ARMINIUS.

Double-turreted monitor, with ram bow and no overhang. Light flying deck, single screw. (American type modified.)

PRINZ ADALBERT.

Armored belt, double redoubt. Long ram bow, round stern, single screw, half sail-power. The belt encircles the water-line to the height of the upper deck. The curve of the ram bow is carried up, forming a spar-deck redoubt, giving protection to a single heavy bow-gun working in one port. A second redoubt, well aft, gives protection to two guns, each

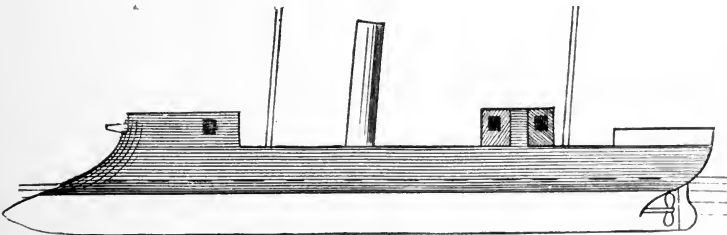

PRINZ ADALBERT.

working in two ports for fore-and-aft and beam fire. A superstructure aft cuts off the stern-fire from these guns, and the forward redoubt cuts off the bow-fire. The shape of both of the redoubts is nearly circular. The Stonewall (Confederate) belonged to this type. (Sister ships.)

WESPE. VIPER. BIENE. MÜCKE.
 SCORPION. BASILISK. RHEIN. MOSEL.

(Four others not yet named.)

Small, light-draft, armored gun-boats. All except the Rhein and Mosel have an armored belt and a horseshoe-shaped traverse, giving protection to the crew of a single barbette gun, which gives only bow-fire. They are provided with rams. The Rhein and Mosel are light-draft monitors, similar to the Austrian Danube gun-boats. (See Austrian Danube monitors.) The Wespe class belongs to the English Staunch and the French Farcy type.

GERMAN UNARMORED FLEET.

(FAST CRUISERS.)

TYPE AND NAME.		Displacement.	Maximum Speed.	BATTERY.
		Tons.	Knots.	
Iron Gun-deck Corvettes.	Leipsic.....	3,863	16	} XII 6¾-inches.
	Bismarck.....	3,863	16	
	Blücher.....	2,460	15	} XVI 5¾-inches.
	Stosch.....	2,460	15	
	Moltke.....	2,460	15	
	Sedan.....	2,460	15	
	One other.....	2,460	15	
Wooden Gun-deck Corvettes.	Freya.....	1,954	14½	} II 6¾-inch, VI 5¾-inch.
	Louise.....	1,665	14	
	Ariadne.....	1,665	13	

GERMAN GENERAL-SERVICE FLEET.

(OLD-TYPE STEAM CRUISERS.)

TYPE AND NAME.		Displacement.	Maximum Speed.	Guns.
		Tons.	Knots.	
Wooden Gun-deck Corvettes.	Elizabeth	2,428	12	18
	Hertha	2,227	10¾	19
	Vineta	2,227	11	19
2d Class Corvettes.	Augusta	1,760	13¾	10
	Arcona.	1,760	13½	10
	Gazelle	1,760	13½	10
	Nymphe	1,760	13¾	10
	Medusa	1,760	13¾	10
	Victoria	1,760	14	10
	Ariadne	1,650	12½	6
	Albatross	695	10½	4
Gun-boats.	Nautilus	695	10½	4
	Wolf	482	10½	4
	Hyäne	482	10½	4
	Cyclop	395	8½	4
	Blitz	395	8½	4
	Two others	395	8½	4
	Komet	340	8½	3
	Meteor	340	8½	3
	Delphin	340	8½	3
	Drache	340	8½	3
	Otter	130	8½	3
	Fuchs	260	8	1
	Habicht	260	8	1
	Hai	260	1
	Tiger	260	1
	Natter	260	..	1
	Salamander	260	1
Scorpion	260	1	
Sperber	260	1	

GERMAN GENERAL-SERVICE FLEET—(CONTINUED.)

(OLD-TYPE STEAM CRUISERS.)

TYPE AND NAME.		Displacement.	Maximum Speed.	Guns.
		Tons.	Knots.	
Transports and Dispatch Vessels.	Hohenzollern.....	1,690	2
	Three others.....	1,690	2
	Pommerania.....	380	2
	Lorelei.....	380	2
	Grille.....	337	2
	Falke.....	1,004	2

Harbor-tugs. Torpedo-launches. Hulks. Guard-ships.

GREECE.

ARMORED VESSELS.

TYPE AND NAME.		Displacement.	Armor.	Maximum Speed.	BATTERY.
		Tons.	Inches	Knots.	
Broadside Frigate.	Olga.....	2,060	4½ to 5	10	II 9-inch. X 7-inch Armstrong.
Casemate Gun-boat.	Georgius.....	1,800	7	13	II 9-inch.

UNARMORED VESSELS.

1 Screw Corvette, Hellas.
5 Yachts (old blockade runners).

1 Screw Gun-boat.
7 Pinnaces and small Gun-boats.

OLGA.

Completely armored broadside frigate or large corvette; ram bow, straight stern. Armor-belt enclosing water-line to the height of spar-deck beams. (See Maria Pia, Italian.)

GEORGIUS.

Armored belt and hexagonal casemate amidships. The rail forward of the casemate is carried inboard parallel to the keel to open the bow-fire from the casemate. Aft, the rail is cut in for some distance from the casemate, and given a

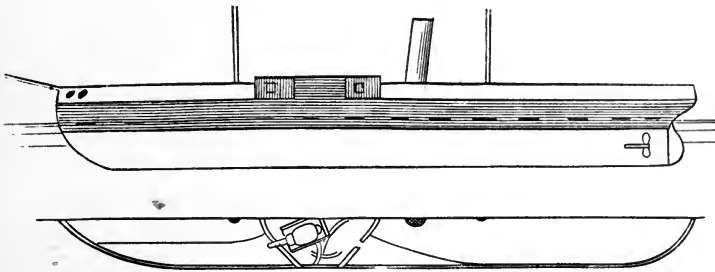

GEORGIUS.

rank tumble home, to open the after-fire. No stern-fire. Double screws, three-quarter sail-power. The armor has a backing of ten inches. The guns work on turn-tables, one on each side, and have a firing-angle of about 110° from each port.

HOLLAND.

ARMORED FLEET.

TYPE AND NAME.	Length between Transversals.		Breadth of Beam.		Maximum Draft.		Displacement.		Greatest thickness of Armor.		Least thickness of Armor.		Backing.		Indicated Horse-power.		Maximum Speed.		Date of Launch.		BATTERY.
	Ft.	In.	Ft.	In.	Ft.	In.	Tons.	In.	In.	In.	In.	In.	In.	Knots.	Year.	Year.					
Ram Turret- ships.	Konig der Nederlanden	280	51	19	8	5,197	8	6	11.8	4,630	11.9	1874	{ IV 11-inch Armstrong. IV 4 $\frac{3}{4}$ -inch Krupp.								
	Prins Hendrik	290	44	18	10	2,360	4.5	4	9.8	2,400	12.1	1866	{ IV 9-inch Armstrong. IV 4 $\frac{3}{4}$ -inch Krupp.								
Rams.	Stier	193	36	6	15	2,060	6	4	11.8	2,200	12.3	1867	IV 9-inch Armstrong.								
	Schorpioen	193	36	6	15	2,140	6	4	11.8	2,360	12.8	1867	IV " "								
	Buffel	205	40	15	6	2,162	6	4	9.8	2,300	12.7	1867	{ IV 9-inch Armstrong. IV 3 $\frac{1}{2}$ -pdr. smooth.								
	Guinea	205	40	15	6	2,338	6	4	9.8	2,200	12.7	1867	{ IV 9-inch Armstrong. IV 3 $\frac{1}{2}$ -pdr. smooth.								
1st Class Ram Monitor.	Draak	195	46	10	10	2,121	8	6	11.8	800	10	1877	II 11-inch Krupp.								

2d Class Ram Monitors.	Matador.....	195	46	9 10	1,623	4.5	4.5	9.8	680	8	1877	II 11-inch Krupp.
	Luipaard.....	187	44	8 8	1,500	4.5	4.5	9.8	680	9	1876	I "
	Hyaena.....	187	44	8 6	1,540	3	4.5	9.8	680	9	1870	
	Panther.....	187	44	8 6	1,540	3	4.5	9.8	680	9	1871	
	Haai.....	187	44	8 6	1,540	3	4.5	9.8	680	9	1868	
	Wesp.....	187	44	8 6	1,540	3	4.5	9.8	680	9	1869	
	Adder.....	187	44	8 6	1,540	3	4.5	9.8	680	9	1868	
	Krokodil.....	187	44	8 6	1,505	2.9	5.5	11.8	630	9	1868	II 9-inch Armstrong.
	Helligerlee.....	187	44	8 6	1,505	2.9	5.5	11.8	630	9	1868	
	Cerberus.....	187	44	8 6	1,505	2.9	5.5	11.8	630	9	1869	
Monitors.	Bloedhond.....	187	44	8 6	1,505	2.9	5.5	11.8	630	9	1869	
	Tyger.....	187	44	8 6	1,391	2.9	5.5	11.8	630	9	1868	
	Number 1.....	164	38	6 11	394	2.9	4.5	10.6	360	9	1863	II 60-pdr. smooth.
Gun-boat.	Vahalis.....	150 11	18 4	4 11	256	4.5	4	7	200	8	1870	II "
	Isala.....	150 11	18 4	4 3	360	5	4.3	5.1	320	8	1876	
	Rhenus.....	150 11	18 4	4 3	360	5	4.3	5.1	320	8	1877	
	Mosa.....	150 11	18 4	4 3	360	5	4.3	5.1	320	8	1878	II 4¾-inch Krupp.
	Merva.....	150 11	18 4	4 3	360	5	4.3	5.1	320	8	1878	

KONING DER NEDERLANDEN.

PRINZ HENDRIK.

Double-turreted, high-sided, sea-going monitors. Armored belt and casemate; ram bow, straight stern. The belt encloses the water-line to the height of the main-deck beams. The casemate encloses the bottoms of the turrets, engines, and boilers, occupying the middle third of the vessel. The fore-and-aft fire of the turret guns is completely cut off by the superstructures forming forecabin and cabin, and which rise to the height of the top of the turrets.

These superstructures are cut in at the ends nearest the

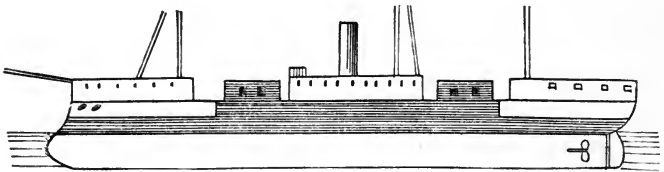

PRINZ HENDRIK.

turrets to open the fire as much as possible, increasing slightly the firing-angle and almost completely destroying the necessary freeboard. Between the turrets is a third superstructure, musket-proof, protecting the approaches to the boilers and engines. At the forward end of this superstructure is a musket-proof pilot-house. Double screws, full sail-power, with tripod fore and main masts. These ships are a medium between the Wyvern and the ill-fated Captain. Bow and stern fire are secured by light unprotected guns.

STIER.	SCHORPIOEN.	BUFFEL.	GUINEA.
DRAAK.	MATADOR.	LUPARD.	HYAENA.
PANTER.	HAAL.	WESP.	ADDER.

High-sided ram monitors. Armored belt, casemate, and single turret. Ram bow and round stern. The belt encircles

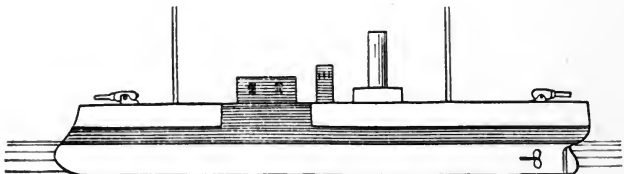

BUFFEL.

the water-line to the height of the main-deck beams. The casemate surrounds the foot of the turret only. The turret

has perfect all-around fire, being large enough to give stern-fire past the smoke-stack. A superstructure gives a full free-board all around as high as the top of the casemate, furnishing quarters. The upper deck carries a light barbette battery of bow, stern, and broadside guns. Twin screw and half sail-power.

KROKODIL.
BLOEDHOUND.

HEILIGERLEE.

CERBERUS.
TIJGER.

Single-turreted low monitors, with high superstructures

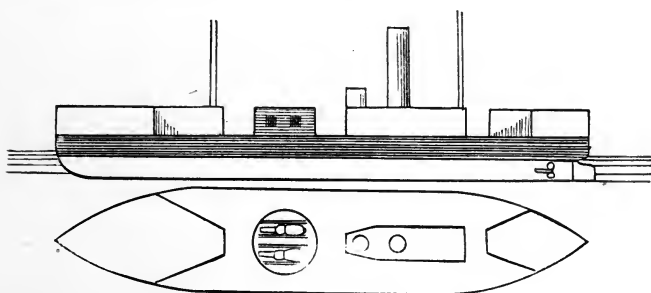

BLOEDHOUND.

forward and abaft the turret cutting off the fore-and-aft fire. Twin screws, half-sail power.

VAHALIS.

ISALA.

RHENUS.

MOSA.

MERVA.

Light-draft, single-turreted monitors. The turret is elevated and surrounded by a casemate having a tumble home of 35° .

DUTCH UNARMORED FLEET.

(FAST CRUISERS.)

TYPE AND NAME.		Displacement.	Indicated Horse-power.	Maximum Speed.	Date of Launch.	BATTERY.
		Tons.		Knots.	Year.	
1st-class Cruisers.	Atjeh	3,108	2,900	14	1876	VI 6.8 inch Krupp.
	Tromp	3,108	2,900	14	1877	
	De Ruyter	3,108	2,900	14	1878	
3d-class Cruisers.	Suriname	836	350	1876	I 5.8-inch Krupp. III 4.7-inch " I 5.8-inch " III 4.7-inch " I 5.8-inch Krupp. III 4.7-inch "
	Bonaire	836	350	1876	
	St. Eustatius	836	350	1877	
	Samarang	836	350	1877	
	Batavia	836	350	1878	
	Macassar	836	350	1878	
	Padang	836	350	1878	

DUTCH GENERAL-SERVICE FLEET.

(OLD-TYPE STEAM CRUISERS.)

TYPE AND NAME.		Displacement.	Indicated Horse-power.	Construction Material.	Date of Launch.	Guns.
		Tons.			Year.	
Pri-gate.	Evertsen	3,300	1,000	Wood	1857	51
	Silverin Kruis	2,160	1,480	"	1869	12
Corvettes.	Van Galen	2,160	700	"	1872	12
	Leenwarden	2,030	700	"	1861	14
	Curaçao	2,030	700	"	1863	14
	Watergeus	1,490	770	"	1864	6
	Marnix	1,490	770	"	1867	6
Sloops.	Alkmaar	1,010	600	Composite	1874	3
	Prinses Maria	760	250	Wood	1862	7
	Cornelius Dirks	760	250	"	1859	6
	Aruba	730	250	Composite	1873	3
Paddle steamer.	Valk	1,220	800	Wood	1864	6

DUTCH EAST INDIA GENERAL-SERVICE FLEET.

(OLD-TYPE STEAM CRUISERS.)

TYPE AND NAME.		Displacement.	Indicated Horse-power.	Construction Material.	Date of Launch.	Guns.
		Tons.			Year.	
Paddle Steamers.	Soeribaija	1,450	975	Wood	1867	2
	Merapi.....	1,150	975	Iron sheathed	1874	6
	Bromo.....	1,150	975	"	1874	6
	Sumatra.....	950	550	Iron	1867	4
	Borneo.....	950	550	"	1867	4
	Banka.....	950	550	"	1867	4
	Timor.....	950	550	"	1867	4
	Oenarang.....	650	360	"	1875	3
	Soembing.....	650	360	"	1877	4
	Sindoro.....	650	360	"	1877	4
	Onrust.....	190	290	"	1863	3
	Salak.....	200	290	"	1875	3
	Admiral v. Kinsbergen.....	180	200	"	1854	1
Screw Steamers.	Aart Van Ness.....	650	280	Wood	1863	2
	Schouwen.....	650	280	"	1863	6
	Bommelerward.....	650	280	"	1862	6
	Riouw.....	730	340	Composite	1872	3
	Banda.....	730	340	"	1872	3
	Amböina.....	730	340	"	1873	3
	Deli.....	730	340	"	1873	3
	Sambas.....	750	350	"	1874	3
	Pontianak.....	750	350	"	1873	3
	Bandjermassing.....	750	350	"	1874	3
Palembang.....	750	350	"	1874	3	
Surveying Steamer.	Hydrograaf.....	730	340	"	1873	3

TYPE AND NAME.	Length between Perpendiculars.	Breadth of Beam.	Maximum Draft.	Displacement.	Indicated Horse-power.	Maximum Speed.	Greatest thickness of Armor.	Least thickness of Armor.	Backing.	Date of Launch.	BATTERY.	
												Ft.
Casemate and Keeloubt Frigates.	Dandolo.....	340	26	10,650	7,500	14	21½	13¾	19¼	1876	IV 17-inch, IV 4¾-inch.	
	Duilio.....	340	26	10,650	7,500	14	21½	13¾	19¾	1878		
	Italia.....	400	30	13,480	9,000	15		
	Lepanto.....	400	30	13,480	9,000	15		
Case-mate Frigates.	Palestro.....	365	25	5,780	3,200	12.2	8½	6	24¼	1872	I 11-inch, IV 10-inch.	
	Principe Amadeo.....	365	25	5,780	3,200	12.9	8½	6	24¼	1873		
	Venezia.....	250	25	5,699	4,000	13	6	4	26	1871	VIII 10 inch, I 9-inch.	
	Roma.....	250	25	5,699	3,500	13	6	4	26	1869		
	Broadside Frigates.	Ancona.....	256	22	4,194	3,000	11½	4½	3	13	1863	IX 8 inch, II 9-inch.
		Castelfidardo.....	256	22	4,149	3,000	11½	4½	3	13	1863	
Maria Pia.....		256	22	4,194	3,000	11½	4½	3	13	1864		
San Martino.....		256	22	4,194	3,000	11½	4½	3	13	1864		
Conte Verde.....		256	22	4,194	3,000	11½	4½	3	13	1861		
Floating Batteries.	Messina.....	256	22	4,194	3,000	11½	4½	3	13	1861	VI 9 inch, I 8-inch.	
	Terribile.....	198	18	2,700	1,800	12	4½	3	9	1862		
	Formidabile.....	198	18	2,700	1,800	12	4½	3	9	1862		
Monitors for Ram.	Varese.....	198	13	2,600	1,000	9	4½	3	9	1862	IV 8-inch I 6½-inch.	
	Affondatore.....	290	20	4,070	3,200	13	5	3	9	1865		

DANDOLO.

DUILIO.

ITALIA.

LEPANTO.

Armored-casemate, double-turreted monitor ships. Ram bow, overhanging stern. The casemate surrounds the boilers, engines, and turrets, occupying about one third of the ship. The lower edge of the casemate is carried forward and aft in a steel deck three inches thick, the deck curving down forward below the point of the ram. The upper deck is also

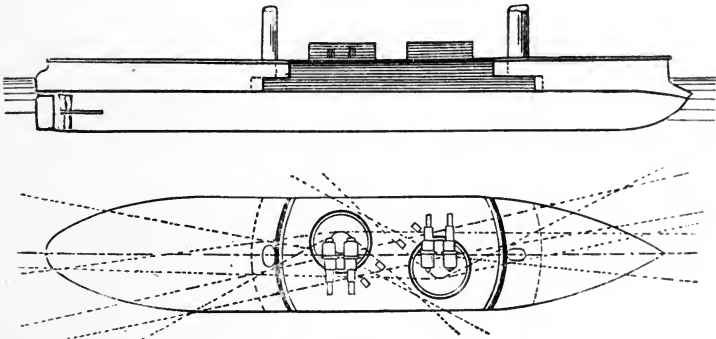

DUILIO.

plated fore and aft with two-inch steel plates. The turrets are placed diagonally to open full fore-and-aft and beam fire. The two sets of boilers and engines are grouped one abaft the other, the boilers being arranged transversely between the sets of engines. Twin screws, no sail-power, no superstructure. Designed by Admiral Brin.

PALESTRO.

PRINCIPE AMADEO.

Armored belt and double casemate. Swan breast, ram bow, straight stern. The belt encloses the water-line to the height of the main-deck beams. Forward is a double casemate or traverse (the rear being unprotected) rising to the top of the topgallant forecastle, and giving protection to two heavy guns on the main-deck, working each in two ports for bow and beam fire, and one heavy rifle on the upper deck working in two ports over the forward main-deck ones for bow-fire. The bow-frames are distorted to open the fire on the main-deck. Aft is a long main-deck traverse protecting

four heavy rifles, giving two guns for stern-fire and, if desired, three for beam-fire (one gun may be shifted from side to side).

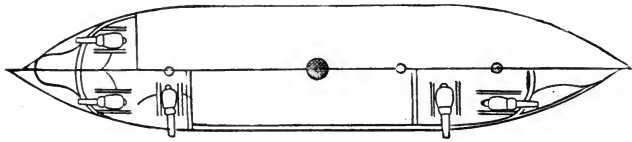
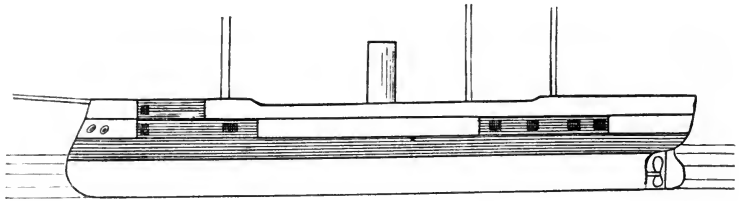

PALESTRO.

The stern-frames, like those of the bow, are distorted to get stern-fire. Single screw, full sail-power.

VENEZIA.

ROMA.

Armored belt, long main-deck casemate, and upper-deck bow and stern traverses. Straight bow, round stern. The

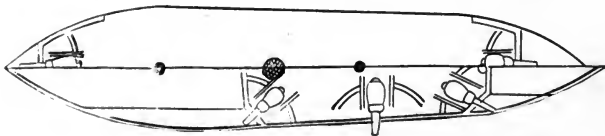
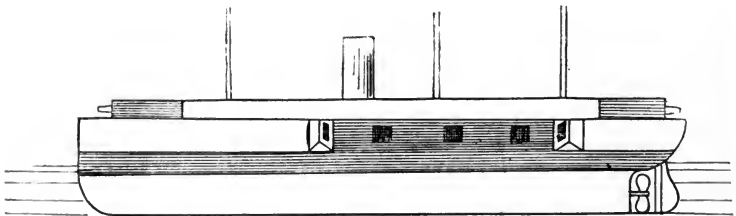

VENEZIA.

belt encircles the water-line to the height of the main-deck beams. The casemate is long and trapezoidal in shape, with the corners cut to allow angular ports for fore-and-aft fire.

The side forward and abaft the casemate is given a rank tumble home to open the fore-and-aft fire. The casemate surrounds the boilers and engines. On the spar-deck are bow and stern traverses, each protecting a gun working in a single port. The bow and stern upper rail is cut off by the traverses sufficient to give them square fronts. Single screw, full sail-power.

ANCONA. CASTELFIDARDO. MARIA PIA.
SAN MARTINO. CONTE VERDE. MESSINA.

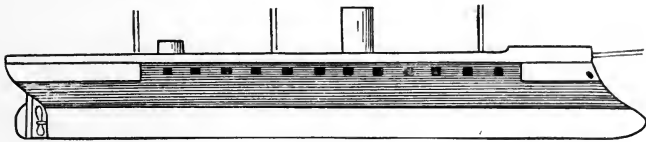

MARIA PIA.

Armored-belt and long-casemate, broadside frigates. Ram bows and round sterns. The armored belt encloses the water-line to the main-deck beams, and is carried up in the casemate to the spar-deck beams. No fore-and-aft fire except from light upper-deck guns. An armored pilot-house just forward of the mizzen-mast. Single screw, full sail-power.

TERRIBILE. FORMIDABILE. VARESE.

Old-type floating batteries. The Varese has the corners of her casemate cut to give fore-and-aft and beam fire. Walls of casemate tumble home at a sharp angle. Ram bows, twin screws, no sail-power.

AFFONDATORE.

Double-turreted monitor ram. High-sided, with half sail-

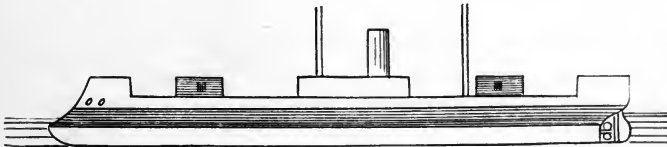

AFFONDATORE.

power and superstructures forward and abaft the turrets. Armored belt enclosing the water-line to the upper-deck beams.

Long ram bow, continued up and forming a topgallant fore-castle nearly as high as the top of the turret. Musket-proof superstructure surrounding the engine-room. Stern-frames carried up to form a spar-deck cabin. No fore-and-aft fire. Single screw. This vessel was the Italian flag-ship at the Battle of Lissa.

ITALIAN UNARMORED FLEET.

(RAPID CRUISERS.)

TYPE AND NAME.		Displacement.	Maximum Speed.	BATTERY.
		Tons.	Knots.	
2d Class Corvettes.	Cristoforo Colombo	2,500	16.2	V 4¾-inch.
	Staffetta	1,485	12.5	} V 3-inch.
	Rapido	1,426	11.8	
Gun-boats.	Agostin	650	17	} II 4¾-inch.
	Barbarigo	650	17	
	Marcantonio	650	17	
	Colonna	650	17	
Torpedo Vessels.	Pietro Micca	512	14.5	} Torpedoes.
	Seb. Verniero	512		
	And. Provano	512		

ITALIAN GENERAL-SERVICE FLEET.

(OLD-TYPE STEAM CRUISERS.)

TYPE AND NAME.		Displacement.	Construction Material.	Guns.
Frigates.	Vittorio Emanuele.....	3,420	Wood	22
	Maria Adelaide.....	3,460	"	24
Corvettes.	Vettor Pisani.....	1,580	"	14
	Carracciolo.....	1,580	"	6
	Garibaldi.....	1,440	"	8
Dispatch Vessel.	Vedetta.....	790	Iron	4
1st Class Gun-boats.	Scilla.....	1,050	Wood	4
	Cariddi.....	1,050	"	4
	Guardiano.....	265	Iron	1
	Sentinella.....	265	"	1
2d Class Gun-boats.	Veloce.....	274	Wood	4
	Ardita.....	274	"	4
	Confienza.....	262	"	4
Paddle-wheel Corvettes.	Governolo.....	1,700	"	8
	Ettore Fieramosca.....	1,400	"	6
	Guiscardo.....	1,400	"	6
	Archimede.....	1,300	"	6
Dispatch Vessels.	Esploratore.....	1,080	"	4
	Messaggiere.....	1,080	"	4
Transports.	Citta di Genova.....	3,730	"	4
	Citta di Napoli.....	3,730	"	8
	Europa.....	2,300	Iron	2
	Conte Cavour.....	1,870	"	2
	Washington.....	1,400	"	2
	Doria.....	1,100	"	2
Depot-Vessel.	Vulcano.....	276	Wood	..

Hulks. Guard-ships. School-ships. Harbor-tugs.

JAPAN.

ARMORED FLEET

TYPE AND NAME.	Length between Perpendiculars.	Breadth of Beam.	Draft.	Displacement.	Indicated Horse-power.	Maximum Speed.	Greatest thickness of Armor.	Least thickness of Armor.	Backing.	Date of Launch.	BATTERY.
Armored Corvettes. { Foo-Soo	Ft. 220	Ft. in. 48	Ft. 18	Tons. 3,718	3,500	Knots. 13	In. 9	In. 8	In.	Year. 1877	IV 9½-inch, II 6¾-inch Krupp.
Kong-Go	231	40 9	18	3,650	2,450	13¾	5	5	1877	} III 6¾-inch, VI 5¾-inch Krupp.
Hi-Yei	220	48	18½	3,718	2,400	14	5	5	1878	
Ram. { Ko-tets-ten	158	27	13	3,863	1,000	9	4½	3	12	1864	III 9-inch Armstrong.
Broadside Corvette. { Rto-jio-kan	213	31 6	17½	4	4	1864	II 6-inch, X 5-inch cast-iron rifles.

JAPANESE UNARMORED FLEET.

TYPE AND NAME.		Length between Perpendiculars.	Breadth of Beam.	Draft.	Guns.
		Ft.	Ft.	Ft.	
Corvettes.	Tsu-ku-ba-kan.....	197	29½	15	10
	Nishin-kan.....	203	29	14	7
	Kasuga-kan.....	242	27	10	7
Gun-boats.	Ho-shio-kan.....	150	21	7	2
	Moshium-kan.....	150	21	7	4
	Dai-itchi-Taibo-kan.....	131	22	7	4
	Dai-ni-Taibo-kan.....	131	22	7	2
	Un-yo-kan.....	4
	Tchiotagata-kan.....	3
Trans-ports.	Osaka-maru.....
	Two others.....

FOO-SOO.

Armored belt and redoubt. Ram bow, round stern. Belt encircling the water-line to the height of the main-deck beams, and covering the ram. Square central redoubt, having an overhang of about three feet, the corners being cut off to permit angular ports for fore-and-aft and beam fire. The sides above the main-deck beams are given a rank tumble home to open the fore-and-aft fire of the redoubt. On top of the redoubt a heavy rifle is mounted on each side in barbette, giving a firing-angle of 180°. Designed by Reed. This ship resembles very closely in type the French Redoubtable.

KONG-GO.

HI-YEI.

Armored-belt, broadside corvettes. The belt comes to the height of the upper-deck beams, but ends short of the bow and stern in an armored bulkhead. There is no fore-and-aft fire from the main battery. Two heavy bow-guns are carried under the fore-castle in recessed ports, giving bow and beam fire. One stern-gun working in two recessed ports gives stern and beam fire. Single screw, full sail power. Long yacht bow and round stern.

KO-TETS-EEN (LATE STONEWALL).

Armored belt and redoubt, long ram bow, round stern, single screw, and half sail-power. This vessel is almost the exact counterpart of the Prinz Adalbert (German). Both ships were built at Bordeaux.

RIO-JIO-KAN.

Partial armored belt, from about three feet below the waterline to the height of the spar-deck beams, ending forward and abaft the battery in armored bulkheads. There is no fore-and-aft fire from the battery, and only bow-fire from a light rifle. The disposition of the armor is similar to that of the Warrior. The hull is divided into several large water-tight compartments, and the long yacht-bow is strengthened for ramming. Single screw, full sail-power.

NORWAY AND SWEDEN.

ARMORED FLEET.

NORWAY.

TYPE AND NAME.	Draft.		Indicated Horse-Power.	Maximum Speed.	Armor at Water-line.		Armor on Turret.	Backing.	BATTERY.
	Ft. in.	Tons.			In.	In.			
Monitors.	Scorpionen.....	11 6	1,423	380	7	5	11.8	26	II 11-inch Armstrong.
	Mjölner.....	11 6	1,490	460	7	5	11.8	26	
	Thrudvang.....	11 6	1,490	500	8	5	11.8	26	
	Thor.....	13 2	1,970	600	9	7	13.7	9	
	Odin.....	13 2	1,970	600	9	7	13.7	9	

SWEDEN.

Monitors.	John Ericsson ..	11 6	1,475	380	7	5	10½	31½	II 15-inch Rodman smooth-bore. II 9¼-inch Finsborg Rifle.
	Thordön.....	11 6	1,475	380	7½	5	10½	26	
	Tyrfing.....	11 6	1,475	380	7½	5	10½	26	
	Loke.....	12 2	1,575	430	8	5	17¾	24½	
Monitor Gun-boats.	Garmer.....	6 6	256	90	5½	1½	6	7¾	I 9¼-inch Armstrong.
	Fenris.....	8 3	256	43	6	1½	10½	33¾	
	Sköld.....	7 6	236	17	3¾	1½	8½	33¾	
	Gerda.....	8 9	453	133	8	2½	14	33¾	
	Hildur.....	8 9	453	133	8	2½	14	33¾	
	Björn.....	8 9	453	155	8	2½	14	33¾	
	Berserk.....	8 9	453	155	8	2½	14	33¾	
	Folke.....	8 9	453	155	8	2½	14	33¾	
	Sölwe.....	8 9	453	155	8	2½	14	33¾	
	Ulf.....	8 9	453	155	8	2½	14	33¾	
One other.....	8 9	453	155	8	2½	14	33¾		

SCORPIONEN.	MJÖLNER.	THRUVDVANG.	THOR.
JOHN ERICSSON.	THORDON.	TJIFING.	LOKE.

Low freeboard, single-turreted monitors. (See Passaic, American.)

ODIN.

Armored belt and casemate. Ram bow, straight stern, low freeboard. The Odin belongs to the floating-battery type; her casemate rising above the deck-level with tumble-home sides, and ports in all four faces for all-around fire.

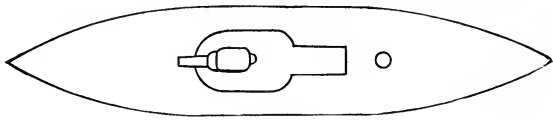
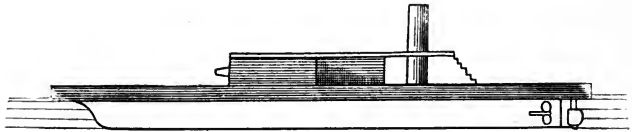

GARMER.

THE TWELVE SWEDISH MONITOR GUN-BOATS.

Armored belt and fixed turret, twin screws, no sail-power. The turret is dome-shaped, with a small dome-shaped armored pilot-house on its after-end. The sides of the turret curve into a steep glacis, which is carried out nearly to the side of the ship, the deck in wake of the turret being merely a narrow platform for passing fore and aft without difficulty. The single heavy gun is worked on a turn-table in five ports for all-around fire. The after-part of the turret is carried on in a superstructure covering the engines, boilers, and hatchways. A light flying deck or bridge is carried around the upper part of the turret. The armor of the side and turret is curved in every section, so as not to present a fair target for striking in any position. The ellipsoidal bow is very strong, and is heavily strengthened for ramming.

NORWEGIAN AND SWEDISH UNARMORED FLEET.

NORWAY.

TYPE AND NAME.		Displacement.	Speed.	BATTERY.
		Tons.	Knots.	
Frigates.	Kong Sverre	3,472	11	XLIV 32-pdrs.
	Saint Olaf	2,182	10	XXXIV "
Corvettes.	Nordsgernen	1,609	9	XVI "
	Nornen	958	9	XIV "
Gun-boats.	Steipner	580	8	I 10¼-inch, I 5¾-inch.
	Vale	233	8	} I 10¼-inch.
	Uller	233	8	
	Glommen	} II 10¼-inch.
	Lugen	
	Sarpen	
	Rjuken	
	Two others	233	8	I 10¼-inch.
	Fourteen Galleys	I 5¾-inch.

NORWEGIAN AND SWEDISH UNARMORED FLEET—(CONTINUED.)

SWEDEN.

TYPE AND NAME.		Displacement.	Speed.	BATTERY.
Ships of the line.	Stockholm.....	Tons. 2,850	Knots. 10	LXVI 20-pdrs.
	Vanadis.....	2,130	12	XVI 32-pdrs.
Corvettes.	Balder.....	1,880	9	VI 5¼-inch Krupp.
	Gefle.....	1,280	9	VIII " "
	Thor.....	1,070	9	V " "
	Saga.....	1,530	8	VII " "
Gun-boats.	Blenda.....	500	13.2	I 10¾-inch, I 4¾-inch.
	Disa.....	500	13.2	
	Urd.....	500	13.2	
	Verdande.....	500	13.2	
	Skagul.....	536	13.5	
	Skuld.....	536	13.5	
	Sköggald.....	536	13.5	
	Rota.....	536	13.5	
	Svensksund.....	180 to 200	8	I 4¾-inch.
	Hogland.....			
	Motala.....			
	Carlsund.....			
	Allög.....			
Astrid.....				
Ingegud.....				
Sigrid.....	I 5¾-inch.			
Alfhild.....				
Gunhild.....	I 6½-inch.			
Valkyrian.....				
Torpedo Vessel.	Ran.....	630	13	

The Navy is supplied with a number of Thorneycroft torpedo-launches using Whitehead torpedoes.

PERU.

ARMORED FLEET.

TYPE AND NAME.		Displacement.	Maximum Speed.	Date of Launch.	BATTERY.
		Tons.	Knots.	Year.	
Floating Battery.	Independencia.....	1,968	12½	1865	II 7-inch, XII 5¼-inch.
	Atahualpa.....	984	10½	1865	
Turret ships.	Manco Capac.....	1,082	12	1865	} II 9-inch, II 40-pdrs.
Moni-tors.	Victoria.....				
	Loa.....				

PERUVIAN UNARMORED FLEET.

TYPE AND NAME.		Displacement.	Guns.	TYPE AND NAME.		Displacement.	Guns.
		Tons.				Tons.	
Frigate.	Callao	30	Gun-boats.	Chalaco.....	4
	America.....	14		Tumbez.....	4
Corvettes.	Union.....	14		Chanchamaya.....	2
					Colon.....	2

INDEPENDENCIA (wrecked in action with the Covadonga).

Armored casemate, ram bow, straight stern, single screw, half sail-power. The armor covers the water-line and rises to the height of the spar-deck beams, ending forward and abaft the battery in armored bulkheads. There is no fore-and-aft fire from the casemate, this fire being secured by a single bow and a single stern gun mounted on the spar-deck, unprotected.

ATAHUALPA.

MANCO CAPAC.

VICTORIA.

LOA.

Low-freeboard, single-turreted monitors of the American type.

The Atahualpa and Manco Capac are the late American monitors Chickasaw and Winnebago.

P O R T U G A L .

ARMORED CORVETTE.

NAME.	Length between perpendiculars.		Breadth of Beam.	Maximum Draft.	Displacement.		Armor.	Backing.	Maximum Speed.	BATTERY
	Ft.	Ft.	Ft.	Tons.	In.	In.	Knots.			
Vasco de Gama....	216	43	21	2,479	{ 10 to 9 }	10	13½	{ II 10½-in., I 6-in. Krupp. II 40-pdr. Armstrong.		

Armored belt and casemate. (See Foo Soo, Japanese.) Ram bow, straight stern. The belt encircles the hull to the height of the upper deck, coming below the ram. The casemate rises above the deck, the corners being cut to permit angular ports for fore-and-aft and beam fire. The rail is carried back slightly and the casemate has an overhang of three feet, giving the vessel, at a distance, the appearance of a paddle steamer. Single screw, full sail-power.

PORTUGUESE GENERAL-SERVICE FLEET.

TYPE AND NAME.		Displacement.	Guns.	Nominal Horse-power.	Date of Launch.
		Tons.			Year.
Corvettes.	Estephania.....	1,476	19	400	1859
	Bartholomeu Diaz.....	1,243	17	400	1858
	Rainha de Portugal.....	1,020	8	150	1876
	Mindello.....	1,020	8	150	1876
	Duque de Terceira.....	848	5	220	1864
	Sagres.....	814	4	300	1858
	Infante Don Henrique.....	848	10	200	1862
	Sa de Bandeira.....	848	13	200	1862
Gun-boats.	Rio Lima.....	539	5	80	1875
	Tamega.....	539	5	80	1875
Screw Gun-boats.	Sado.....	539	5	80	1875
	Tejo.....	369	2	100	1869
	Douro.....	369	2	100	1873
Paddle Gun-boats.	Quanza.....	369	3	100	1877
	Quelimane.....	286	1	40	1868
	Tete.....	111	1	35	1871
Trans-boats.	Sena.....	111	1	35	1871
	India.....	1,201	2	160	1871
	Africa.....	1,400	2	1875

RUSSIA.

ARMORED FLEET.

TYPE AND NAME.	Length between Perpendiculars.		Breadth of Beam.		Maximum Draft.		Displacement.	Indicated Horse-power.	Maximum Speed.		Greatest thickness of Armor.	Least thickness of Armor.	Beckings.	Date of Launch.	BATTERY.
	Ft. in.	Ft. in.	Ft. in.	Ft. in.	Tons.	Knots.			In.	In.					
Sevastopol.....	300	50 10	25 11	6,300	3,088	12	4½	3	2.6	1863	XVIII	8¼-inch	Aboukoff.		
Petropaulowski.....	300	56	25 3	6,300	2,460	11	4½	3	2.4	1865	XXI	"	I 5.8-inch	Aboukoff.	
Knjaz Pozarski.....	280	49	21	4,500	2,835	10.6	4½	3	1.8	1867	X	"	"	"	
General Admiral.....	285	48	23	4,500	6,300	13	6	4	1	1873	IV	"	II 5.8-inch	"	
Herzog von Edinburgh.....	285	48	23	4,500	6,300	13	6	4	1	1875	IV	"	II	"	
Minin.....	289	49	23 8	5,800	6,300	12	9.2	6	24	1878	IV	"	VIII	"	
Perwenee.....	230	53	17	3,300	800	9	4½	4	10	1863	XIV	"	"	"	
Netronz menya.....	230	53	17	3,300	1,140	8	4½	4	12	1864	XVI	"	I 60-pdr.	smooth.	
Kreml.....	218 6	53	17	3,300	913	8.5	6	4	18	1864	XII	"	V 5.8-inch	Aboukoff.	

Frigates.

Battery Ships.

Peter der Grosse.....	330	64	22	9	9,510	8,700	13.2	17	9	10	1872	IV 12-inch Aboukoff.
Admiral Lazareff.....	260	43	6	19	3,700	2,020	10.8	5½	3	18	1897	VI 9-inch "
Admiral Greigh.....	260	43	6	19	3,700	2,020	10.2	5½	3	18	1868	III 11-inch "
Admiral Cicagoff.....	260	43	6	19	3,700	2,030	10.8	6	4	18	1868	II "
Admiral Spiridoff.....	260	43	6	19	3,700	2,030	10.8	6	4	18	1868	II "
Vice-Admiral Popoff.....	121	121	14		3,550	8.3	16	16	15¾	1875	II 12-inch "
Novgorod.....	101	101	13	2	2,490	6.5	9	8¼	9	1873	II 11-inch "
Carodjezka.....	210	42	11	9	1,835	750	8.7	4½	3¼	18	1867	IV 9-inch "
Russalka.....	210	42	11	9	1,835	750	8.7	4½	3¼	18	1867	IV "
Smertch.....	172	38		1,380	700	8.3	4½	4	7.8	1864	II "
(Stryeletch.....)												
Jedinrog.....												
Latnik.....												
Bronnosec.....												
Urgan.....	200	46	11	6	1,558	{ 340 to 490 }	{ 7 }	12	12	39	1864	II 9-inch Aboukoff.
Tifon.....												
Larva.....												
Perun.....												
Wjestechn.....												
Koldun.....												
Sistov.....		5		512	290	8	3	2	10	1864	II 4¾-inch, I 3¼-inch Aboukoff.
Nikopolis.....		5		512	290	8	3	2	10	1864	

Turret Ships.

Popoff.

Double-turret Monitors.

Single-turret Monitors.

SEVASTOPOL.

PETROPAULOWSKI.

Armored belt and casemate, swan-breasted ram bow, round stern, single screw, full sail-power. The belt encircles the water-line to the height of the main-deck beams. The casemate rises to the spar-deck beams, with armored bulkheads forward and abaft. No fore-and-aft fire from the casemate, the ships being wall-sided. (See Achilles, English.)

KNJAZ POZARSKI.

Armored belt and casemate; ram bow, round stern, single screw, full sail-power. Corners of casemate cut to permit angular fire. (See Hercules, English.) Double iron hull, very flat-bottomed, and having two bilge-keels in place of a main-keel. Bow and stern fire from light spar-deck guns, unprotected.

PERWENEC.

NETRONZ-MENYA.

KREML.

Completely armored broadside frigates, ram bow, overhang stern, single screw, full sail-power. (See Numancia, Spanish.)

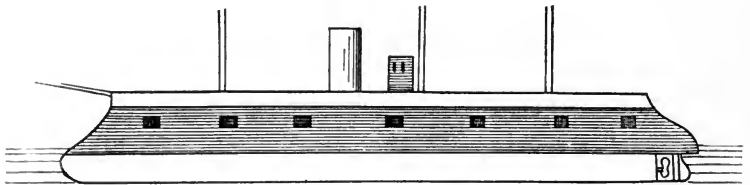

PERWENEC.

The Kreml has her bow and stern spar-deck rails recessed for fore-and-aft fire. (See Amethyst, English.) The sides of these ships tumble home from the water-line at an angle of 15° .

LAZAREFF.

GREIGH.

CICAGOFF.

SPIRIDOFF.

American type of low-freeboard, revolving-turreted monitors, with strengthened bows for ramming. The Lazareff and Greigh have three turrets, the others two.

SISTOV.

NIKOPOLIS.

Floating batteries. Armored belt and casemate built on upper deck, with ports in all four faces for all-around fire. (See Embuscade, French.)

GENERAL ADMIRAL.

HERZOG VON EDINBURGH.

Armored belt and armored barbette casemate. Straight bow, long, peculiarly-shaped dome stern, single screw, full sail-power. The belt encircles the water-line to the height of the main-deck beams, and the main-deck is protected by steel plates two inches in thickness. The barbette casemate is square, low-

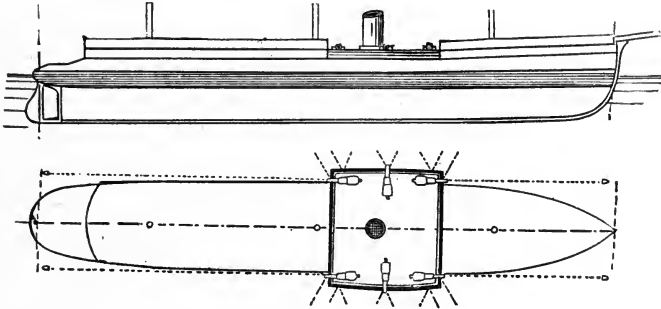

GENERAL ADMIRAL.

browed, and has considerable overhang, rising clear of the spar-deck to a height of about four feet, and protecting the carriages of six heavy pivot-rifles giving clear fore-and-aft and beam fire. The symmetry of the hull is preserved throughout. These ships carry a very great coal supply, sufficient to carry them a distance of 6000 miles at a speed of ten knots.

MININ.

Originally laid down for a casemated monitor, but subse-

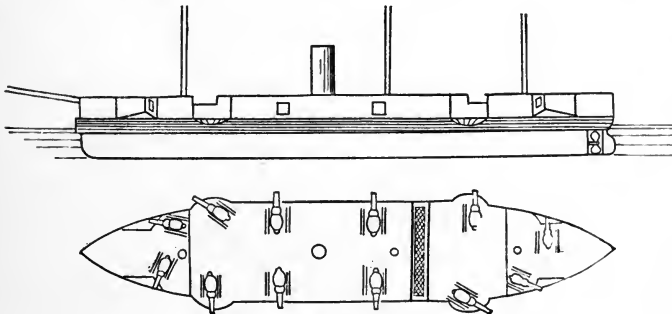

MININ.

quently transformed into an armored-belt corvette. Straight bow and stern, the bow being heavily strengthened for ram-

ming, single screw, full sail-power (double topsail-yards). The belt encloses the water-line to the height of the upper deck. The battery is all on the upper deck and entirely unprotected. The upper-deck rail is so fashioned as to give four guns for bow and four for stern fire. Forward it is recessed on each bow, and similarly astern for the forward and after guns to get bow and beam fire. (See Amethyst, English.) The platform for the next pair of guns (forward and aft) has an overhang of about three feet (see Tourville, French), in order to give them clear fore-and-aft and beam fire also. The remainder of the battery is broadside. Her spar-deck rail is very high (about eight feet); she has a topgallant fore-castle and poop-cabin. Amidships there is a bridge for discharging Whitehead torpedoes.

PETER THE GREAT.

Armored, belt, breastwork, and double-turreted sea-going monitor, straight bow strengthened for ramming, double screws, no sail-power. Musket-proof superstructure between the tur-

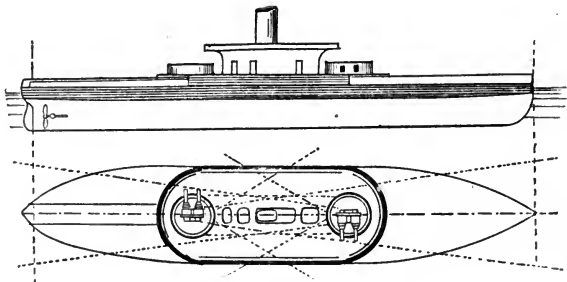

PETER THE GREAT.

rets expanding into a flying deck. The belt has an overhang similar to the American monitors. General type similar to the Dreadnaught.

ADMIRAL POPOFF.

NOVGOROD.

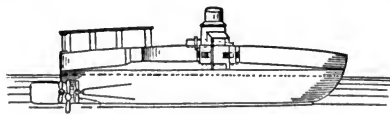

Armored belt and barbette casemate, circular iron-clads. Six screws, no sail-power. The belt of these ships encloses the water-line to the height of the low freeboard. The deck

has more than the ordinary spring, forming a sort of light glacis. In the centre of the vessel rises a circular barbette casemate, covering the carriages of two heavy guns mounted

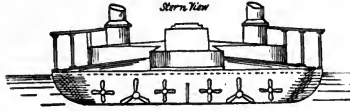

on a turn-table within it. Forward and aft the top of the casemate is continued in a musket-proof superstructure, having

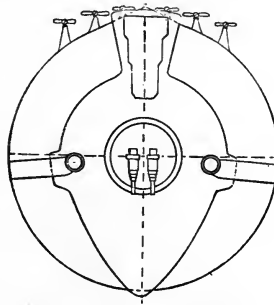

aft a musket-proof pilot-house. The forward section of the vessel is heavily strengthened for ramming. The two smokestacks are placed one either side of the casemate.

DOUBLE AND SINGLE TURRETED MONITORS.

These vessels are of the general type of the American monitors, with slight freeboard, great overhang, and double screws. The turret is raised somewhat higher than in the

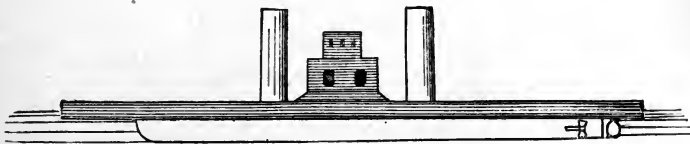

URAGAN.

American monitors, and the foot is protected by a glacis. The turret is also somewhat larger, giving clear fire past the smokestacks. Pilot-house on top of the turret.

RUSSIAN GENERAL-SERVICE FLEET.

TYPE AND NAME.		Displacement.	Guns.	Date of Launch.
		Tons.		Year.
Rapid Cruisers.	Razbojnik	1,334	3	1878
	Nojezbnik.....	1,334	3	1878
	Kreuzer.....	1,334	3	1875
	Dzigit	1,334	3	1876

BALTIC FLEET.

Frigates.	Retziwan	3,823	22	1855
	Svetlana.....	3,202	18	1858
Corvettes.	Askjold	2,402	14	1863
	Wityaz	2,248	9	1862
	Bogatyr.....	2,155	10	1860
	Wargat.....	2,144	18	1862
	Bayan.....	1,997	10	1857
	Voyevoda	903	6	1856
	Boyarin.....	903	6	1856
Clippers.	Griden	903	11	1856
	Almaz	1,821	6	1861
	Zentchug.....	1,807	7	1861
	Jachout.....	1,725	7	1862
	Hydamak	1,204	8	1860
	Izurmed.....	1,807	7	1862
Paddle-wheel Gun-boats.	Vsadnik	1,069	8	1860
	Olaf	1,796	6	1852
	Smieliz.....	1,784	6	1858
	Rurik	1,507	3	1870
	Chrabry	1,450	6	1858
	Vladimir	859	2	1845
	Volga	500	1853
Dnieper.....	500	1853	

BALTIC FLEET—(CONTINUED.)

TYPE AND NAME.		Displacement.	Guns.	Date of Launch.
		Tons.		Year.
Yachts.	Derzava	3,113	6	1871
	Sztandard	895	4	1858
	Szareona	734	4	1874
	Alexandra	228	1851
	Stryelna	159	1857
	Slavanka	182	1874
	Golubka	14	1872
Trans- ports.	Kraary Gorka	1,166	1861
	Artlestchik	550	1858
Gun-boats.	Bakan	284	1857
	Kompas	284	1859
	Seistan	284	1859
	Straz	234	1	1874
	Casovoy	234	1	1874
	Zorkaya	80	1	1873
Rapid Cruisers.	Rossya	4,000	7	1879
	Moskva	3,500	7	1879
	Petersburg	3,500	7	1879

BLACK SEA FLEET.

Corvettes.	Wojin	1,820	4	1858
	Sekol	979	11	1859
	Luica	795	9	1865
	Pamiat Merk	795	9	1865
Paddle Gun-boats.	Turok	425	2	1846
	Taman	505	2	1849
	Elborus	493	4	1854
	Jeriklik	1,145	2	1866
	Livadia	1,984	4	1871

BLACK SEA FLEET—(CONTINUED.)

TYPE AND NAME.		Displacement.	Guns.	Date of Launch.
		Tons.		Year.
Screw Gun-boats.	Bombory	760	4	1852
	Kazbek	764	4	1854
	Gonek	745	1879
	Ingul	678	2	1872
	Redut Kale	468	4	1854
	Pseznape	445	4	1857
	Don	360	2	1856
	Salgir	360	2	1857
	Pitzunda	332	4	1857
	Kelasvy	326	4	1859
	Souksu	326	5	1859
	Taubse	285	3	1858
	Nerpa	380	3	1877
	Novorosyski	247	2	1856
	Abin	264	2	1857
	Vorobay	261	2	1869
	Utka	170	1
	Lebed	170	1
	Golubzik	465	2	1859
	Batzuska	220	1	1857
	Rodimy	216	2	1858
	Sestrica	215	2	1858
	Krikuny	215	2	1858
	Bothumy	215	2	1857
	Brater	212	2	1857
	Matuschka	212	2	1857
	Akerman	110	1	1857
Opyt	230	1	1870	
Meteor	230	1	1868	
Docka	212	1	1858	

BLACK SEA FLEET—(CONTINUED.)

TYPE AND NAME.		Displacement.	Guns.	Date of Launch.
		Tons.		Year.
Rapid Cruisers.	Constantine	1,600	4	1858
	Vladimir.....	1,652	7	1859
	Argonaut.....	715	6	1859
	Vesta.....	1,800	12	1858

SIBERIAN FLEET.

Screw Gun-boats.	Abrek	1,069	7	1860
	Jermak.....	706	4	1870
	Tunguz.....	706	4	1870
	Vostok.....	210	6	1852
Trans- ports.	Japonec.....	1,482	2	1858
	Mandzur	816	2	1858
	Amerika	554	8	1856

CASPIAN FLEET—12 Gun-boats.

ARAL FLEET—8 Gun-boats.

SPAIN.

ARMORED FLEET.

NAME.	Displacement.	Maximum Draft.	Indicated Horse-power.	Maximum Speed.	Greatest thickness of Armor.	Least thickness of Armor.	Backing.	Construction Material.	Date of Launch.	BATTERY.
Vittoria.....	Tons. 6,984	Ft. 27	3,700	Knots. 12½	In. 5½	In. 4	In. 14	Iron	Year. 1867	IV 9-inch, III 8-inch, XII 6½-inch.
Numancia.....	6,992	26½	3,700	12¼	5	4	11	"	1864	IV 10-inch, III " XVI "
Sagunto.....	6,200	26	3,700	12½	6	4	22½	Wood	1876	II " V " X "
Arapiles.....	5,600	25	2,500	12	5	3	26	"	1868	II " II " X "
Zaragoza.....	5,320	25	2,500	11	4¾	3	26	"	1867	IV 9-inch, III 7-inch, XII 6½-inch.
Mendez Nuñez.....	3,200	22	2,250	7	4½	3	20½	"	1861	IV " II 8-inch.
Puigcerda.....	512	6½	200	8	4	3	9	"	1874	I 6½-inch, I 4¾-inch.
Aragon.....
Castilla.....	4	3	9	"	1878
Navarra.....
Duque de Tetuan.....	590	7	309	6	4	3	9	"	1874	IV 4¾-inch, I 6½-inch.

VITTORIA.

NUMANCIA.

ARAPILES.

ZARAGOSA.

MENDEZ NUÑEZ.

Fully armored broadside frigates, ram bow, round stern, single screw, full sail-power. Two armored pilot-houses. The

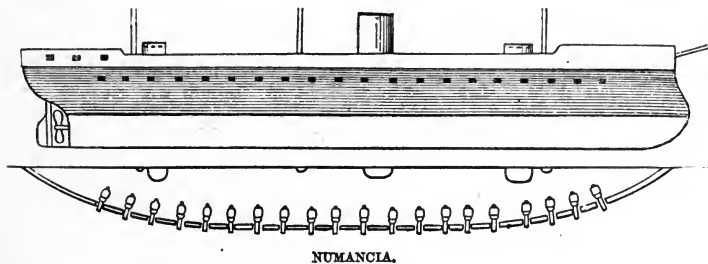

NUMANCIA.

Zaragosa was laid down for a wooden frigate, her design being changed when she was nearly finished.

SAGUNTO.

Armored belt and casemate. Ram bow, round stern, single screw, full sail-power. (See Maria Pia, Italian.)

PUIGCERDA.

Double-turreted, light-draft river monitor. American type.

SPANISH UNARMORED FLEET.

(GENERAL SERVICE.)

TYPE AND NAME.			Displacement.	Guns.	TYPE AND NAME.			Displacement.	Guns.
			Tons.				Tons.		
Screw Frigates.	Villa de Madrid.....	48	Paddle-wheel Corvettes.	Liniers.....	2		
	Almansa.....	48		Vigilante.....	2		
	Navas de Tolosa.....	48		Alerta.....	2		
	Gerona.....	48		Conte del Venadito	2		
	Asturias.....	51		Don Juan de Austria.	1		
	Carmen.....	41		Guadalquiver.....	1		
	Lealtad.....	33		Bazan.....	2		
	Concepcion.....	32		Maria.....	1		
	Blanca.....	38		Transports.	San Quentin.....	1,300		
	Screw Corvettes.	Maria de Molina.....			18	San Francisco de Borja.....	1,300	..
Jorge Juan.....		3	Marquis de la Vitoria		1,200	..		
Sanchez Barcaiztegui		3	Patino.....		1,200	..		
Tornado.....		6	Ferrol.....		800	..		
Consuelo.....		2	San Antonio.....		600	..		
Vencedora.....		3	Screw Gun-boats.		Telegrama.....	1	
Narvaéz.....		3			Criollo.....	1	
Santa Lucia.....		3			Ardid.....	1	
Diana.....		5			Indis.....	1	
Africa.....		3		Caribe.....	1		
Paddle-wheel Corvettes.	Ciudad de Cadiz.....	16		Alarma.....	1		
	Isabel la Catolica....	16		Descubridor.....	1		
	Colon.....	6		Yumuri.....	1		
	Blasco de Garay.....	6		Flecha.....	1		
	Pizarro.....	6		Pelicano.....	1		
	Hernan Cortez.....	6	Cocodrillo.....	1			
	Churruca.....	2	Salamandra.....	1			
	Leon.....	2	Fradera.....	1			
	Vulcano.....	6	Martin Alvarez.....	1			
	Lepanto.....	2	Somorrostro.....	2			
Fernando el Catolico.	3	Ebro.....	2				
Marquis del Douro....	3							

SPANISH UNARMORED FLEET—(CONTINUED.)

(GENERAL SERVICE.)

TYPE AND NAME.			TYPE AND NAME.		
	Displacement.	Guns.		Displacement.	Guns.
	Tons.			Tons.	
Screw Gun-boats.	Bidassoa.....	2	Screw Gun-boats.	Española.....	1
	Teruel.....	2		Argos.....	1
	Nervion.....	2		Lince.....	1
	Toledo.....	2		Centinela.....	1
	Tajo.....	2		Guardian.....	1
	Arlanza.....	2		Vigia.....	1
	Turia.....	2		Astuto.....	1
	Segura.....	2		Almendares.....	1
	Altrevido.....	2		Eco.....	1
	Mindanao.....	2		Destello.....	1
	Calamianes..	1		Contra maestro.....	1
	Paragua.....	1		Marinero.....	1
	Mindoro.....	1		Ericsson.....	1
	Prueba.....	1		Cazador.....	1
	Guadiana.....	3		Canto.....	1
	Sirena.....	3		Gacela.....	1
	Ligera.....	3		Panay.....	1
	Favorita.....	3		Samar.....	1
	Santa Filomena.....	2		Filipino.....	1
	Constancia.....	2		Bulusar.....	1
	Valiente.....	2		Jolo.....	1
	Animosa.....	2		Maribeles.....	1
	Prosperidad.....	2		Arayak.....	1
	Buenaventura.....	2		Pampanza.....	1
	Caridad.....	2		Bojeador.....	1
	Concordia.....	2		Albay.....	1
	Edetna.....	2		Manileno.....	1
Ceres.....	2	Cavitenos.....	1		
Activo.....	1	Callao.....	1		
Cuba.....	1				

JORGE JUAN.

Second-class corvette, single screw, full sail-power. Complete all-around fire obtained by means of overhang in half-

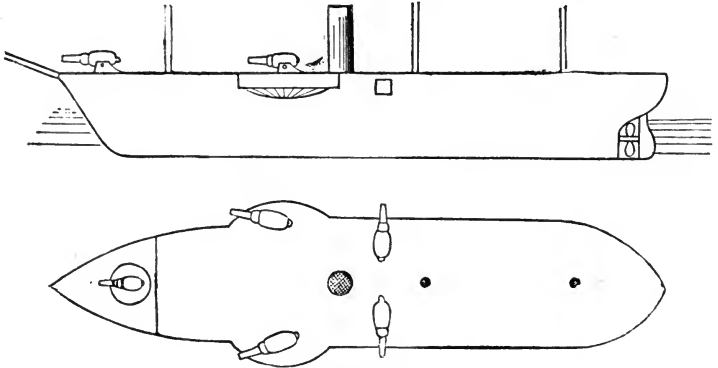

JORGE JUAN.

ports. Forecastle gun sunk in a well so as to cover the slide, carriage, and crew.

TURKEY.

ARMORED FLEET.

TYPE AND NAME.	Length between Perpendiculars.	Breadth of Beam.	Maximum Draft.	Displacement.	Indicated Horse- power.	Maximum Speed.	Greatest thick- ness of Armor.	Least thickness of Armor.	Backing.	Date of Launch.	BATTERY.
	Ft.	Ft.	Ft. in.	Tons.		Knots.	In.	In.	In.	Year.	
Casemate Frigates { Mess oudieh.....	333	59	25	8,994	7,910	13	13½	7	10	1875	XII 10-inch, III 7-inch Armstrong.
{ Nuss Ratijeh.....	292	54	25½	6,900	6,800	13	13½	6	18	1878	X 9-inch, II 7-inch
{ Assar i Tefvik.....	275	50	21	3,143	3,100	13½	8	5½	9	1868	VI 9-inch, II 8-inch
{ Azizie.....	293	56	25	6,500	12	4½	3	10	1864	} XIV 7-inch, X 36-pdr.
{ Orchanie.....	293	56	25	6,500	12	4½	3	10	1864	
{ Mahmudie.....	293	56	25	6,500	12	4½	3	10	1864	
Casemate Frigates { Osmanie.....	293	56	25	6,500	12	4½	3	10	1864	} IV 9-inch
{ Feth i Bulend.....	235	42	18	2,760	13½	9	4½	10	1869	
{ Mukademmi i Hair.....	235	42	18	2,760	12½	9	4½	10	1872	

TURKISH ARMORED FLEET—(CONTINUED.)

TYPE AND NAME.	Length between Perpendiculars.	Breadth of Beam.	Maximum Draft.	Displacement.	Indicated Horse- power.	Maximum Speed.	Greatest thick- ness of Armor.	Least thickness of Armor.	Backing.	Date of Launch.	BATTERY.
	Ft.	Ft.	Ft.	Tons.		Knots.	In.	In.	In.	Year.	
Casemate Frigates.											
Idschalle.....	210	40	17	2,300	11	5½	4	13	1870	IV 9-inch, I 7-inch Armstrong.
Assar i Shefket.....	210	40	17	2,300	11½	5½	3	10	1869	V 9-inch
Nedschin i Shefket.....	210	40	17	2,300	11½	5½	3	10	1868	IV 9-inch
Avni Allah.....	230	36	17	2,320	12½	6	4½	10	1868	IV 9-inch
Muin i Zafir.....	230	36	17	2,320	12½	6	4½	10	1868	II 9-inch, II 7-inch, I 4¾-inch
Hufz i Rahman.....	204	43	9	2,300	12	6	4½	10	1868	
Seif.....	640	404	7	2½	2½	5½	1875	
Hezber.....	640	404	7	2½	2½	5½	1875	
Feth i Islam.....	100	25	6	328	290	8	2½	2	10	1864	II 4¾-inch Krupp.
Beurtlen.....	100	25	6	328	290	8	2½	2	10	1864	
Semendire.....	100	25	6	328	290	8	2½	2	10	1864	
Iskodra.....	100	25	6	328	290	8	2½	2	10	1864	
Podgoriza.....	100	25	6	328	290	8	2½	2	10	1864	

MESS OUDIEH.

NUSS RATIJH.

Armored belt and casemate, ram bow, round stern, single screw, full sail-power. Sister-ships to the Superb (English). The armored belt rises to the height of the main-deck beams, but does not cover the point of the ram. The casemate is of

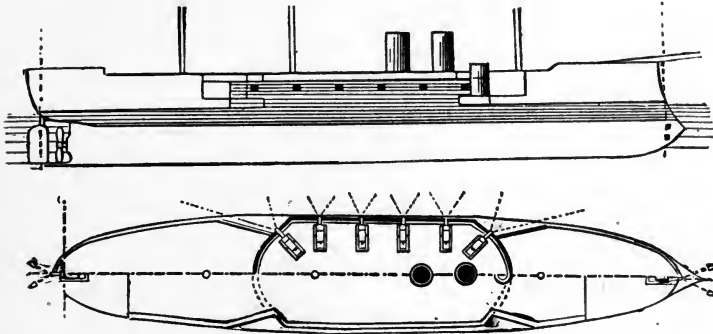

MESS OUDIEH.

the same type as that of the Hereules, but longer, the sides being recessed forward and abaft for angular ports. Fore-and-aft fire is obtained from unprotected bow and stern guns on the spar-deck, working in single ports.

AZIZIE.

MAHMUDIE.

ORCHANIE.

OSMANIE.

Completely armored broadside frigates, with a low redoubt or traverse on the forecastle. Swan-breasted ram bow, round stern, single screw, full sail-power. The bow traverse protects

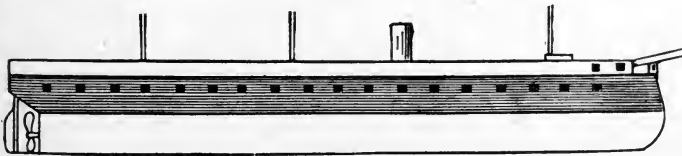

AZIZIE.

two forward guns, each working in two ports, for bow and beam fire. This traverse rounds off the spar-deck rail some distance abaft the stem, which is carried up as a support for the bowsprit. Armored pilot-house at the rear of the traverse.

ASSAR I TEFKIK.

Armored belt, casemate, and two barbette turrets. (See Victoriouse.) Ram bow, dome stern, single screw, full sail-power. Built in France.

FETH I BULEND.

MUKADEMME I HAIR.

Armored belt and casemate, ram bow. (See Mess oudijeh.)

IDSCHLALIE.

ASSAR I SCHEFKET.

NEDSCHEIN I SCHEFKET.

Armored belt, casemate, and single barbette turret amidships, at after-end of casemate. Ram bow, round stern, full sail-power.

AVNI ILLAH.

MUN I ZAFFIR.

Armored belt; two octagonal redoubts having an overhang and connected by an armored curtain in such a manner as to

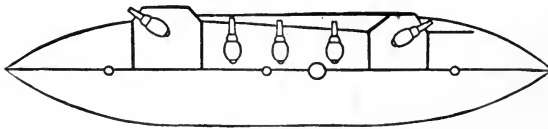
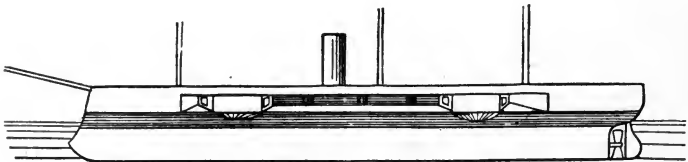

AVNI ILLAH.

give the plan the appearance of a violin. Ram bow, no deck armor. Built at Constantinople.

HUFZ I RAHMAN.

Double-turreted monitor, the forward turret being larger than the after one. Tripod masts. Traverse at the bow. The turrets are revolved by hand-power.

HEZBER.

Single-turreted, light-draft monitor. American type.

FETH I ISLAM.

BEURTLEN.

SEMENDIRE.

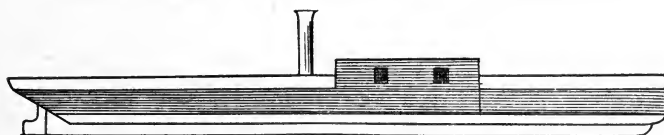

BEURTLEN.

Light-draft, armored belt and casemate vessel; casemate rising above deck with ports on all sides.

TURKISH UNARMORED FLEET.

TYPE AND NAME.		Tonnage.	Date of Launch.	Guns.
Ship of the Line.	Fethie	Tons. 3,380	Year. 1855	67
	Ertogrul	3,344	1863	41
Frigates.	Hudavendighai	2,897	1860	41
	Selimie	4,717	1865	55
	Muhbiri Surur.*	1,477	1851	22
	X (not yet named).....	1,621	Building	9
Corvettes.	Sinope	800	1859	12
	Brussa	800	1859	12
	Mensuré.....	800	1863	12
	Muzafer	800	1863	12
	Libnan	800	1864	12
	Edirné.....	800	1859	12
	Ismid.....	800	1859	12
Transports.	Schaar i Nusret	3,029	1869	2
	Mevret i Nusreb.....	3,029	1869	2
	Sultanie	2,902	1861	4
	Babel.....	1,733	1863	..
	Taif	1,609	1871	4

TURKISH UNARMORED FLEET—(CONTINUED.)

TYPE AND NAME.		Tonnage.	Date of Launch.	Guns.
		Tons.	Year.	
Transports.	{ Assyf	1,609	1875	4
	Mukademie Nusret	2,132	1875	..
	Mukademie Scheref.....	2,132	1875	...
	Peiki Mesret	2,132	1877	...
	Rechbir i Zevfik.....	2,132	1878	..
	Feiz i Bahri	1,490	1848	4
	Essir i Djedid	1,108	1841	6
	Peiki Schfhet	465	1853	4
	Essei i Hair	313	1839	4
	Izzedin.....	1,075	1865	4
Sloops.	Ismail.....	1,075	1865	4
	Zhalia.....	1,075	1865	4
	Fuad.....	1,075	1865	4
	Candia.....	955	1863	6
	Chania.....	829	1863	3
	Pertefi Prale.....	909	1868	..
	Rethmo	777	1869	3.
	Arkadi	767	1867	6
	Mudai i Zafir.....	1,385	1869	4
	Essir i Nazret.....	1,385	1869	4
Schooners.	{ Iskenderje	609	1862	9
	Zohaf.....	609	1862	9
	Mehrih.....	609	1863	9
	Uthralet	609	1863	8
	Beirut.....	609	1859	12
	Seddul Bahr	609	1859	12
	Sijar	220	1865	4
Steamers.	{ Mossul.....	220	1865	4
	Istankieni.....	203	1874	..
	Jali Kioschk	195	1869	1
	Ninani Kavak.....	195	1869	2
	Intibah	258	1866	4
Liver i Deyeh.....	258	1866	4	

TURKISH UNARMORED FLEET—(CONTINUED.)

TYPE AND NAME.		Tonnage.	Date of Launch.	Guns.
		Tons.	Year.	
Steamers.	Muschdi i Rissan	258	1866	4
	Schaheddin	258	1866	4
	Syrat.....	184	1863	2
	Suda	184	1864	2
	Bojana	80	2
	Bai	2
	Eurgen	2
	Sultan's Yacht, Surreja.....	500	1865	4
Dispatch, Transport, and Service Steamers.	Sulhie.....	180	1868	..
	Esser i Nezhret.....	193	1847	2
	Peik i Tjdscheret	193	1845	4
	Mermere	153	1873	..
	Eregli.....	137	1873	..
	Rustschuk.....	112	1873	..
	Jeni Kapu.....	112	1873	..
	Dschebali	112	1873	..
	Kabatsch.....	112	1873	..
	Tophané.....	112	1873	..
	Rassim Pasha.....	77	1873	..
	Dschitana	78	1858	..
	Funduklu	77	1873	..
	Oitenitscha.....	78	1858	..
	Rechber.....	40	1863	..

DANUBE FLOTILLA.

Gun-boats.	Schefket Nuna.....	200	1864	4
	Varna	200	1869	4
	Akka	200	1869	4
Steamers.	Chaireddin.....	474	2
	Rodos.....	203	1874	..
	Isalahat.....	120	1873	..

UNITED STATES.

IRON-CLAD FLEET.

TYPE AND NAME.	Length between Perpendiculars.		Breadth of Beam.		Maximum Draft.	Displacement.	Indicated Horse-power.	Maximum Speed.	Armor Side.	Armor Turret.	Bathing.	Date of Launch.	BATTERY.
	Ft.		Ft.										
Double-turreted Monitors.	Amphitrite.....	250	55	14	3,815	1,800	12	7	10½	8	Building	Year.	
	Miantonomoh.....	250	55	14	3,815	1,800	12	7	10½	8	1876	Building	
	Puritan.....	280	60	17	5,000	3,500	13	Building	IV 10-inch B.L.R.	
	Monadnock.....	250	60	14	3,815	1,800	12	7	10½	8	"	"	
	Terror.....	250	55	14	3,815	1,800	12	7	10½	8	"	"	
	Ajax.....	225	41	13½	2,100	350	8	5	10	4	4	1865	
	Canonicus.....	225	41	13½	2,100	450	8	5	10	4	4	1864	
	Camanche.....	200	46	11½	1,875	350	8	5	11	6	6	
	Catskill.....	200	46	11½	1,875	350	8	5	11	6	6	1863	
	Dictator.....	312	50	20½	4,500	3,500	8	6	15	
Single-turreted Monitors.	Jason.....	200	46	11½	1,875	350	8	5	11	6		
	Lehigh.....	200	46	11½	1,875	350	8	5	11	6		
	Mahopac.....	225	44	13½	2,100	450	8	5	16	4		II 15-inch S.B.
	Manhattan.....	225	44	13½	2,100	450	8	5	10	4		
	Montauk.....	200	46	11½	1,875	350	8	5	11	6		
	Nahant.....	200	46	11½	1,875	350	8	5	11	6		
	Nantucket.....	200	46	11½	1,875	350	8	5	11	6		
	Passaic.....	200	46	11½	1,875	350	8	5	11	6		
	Saugus.....	225	44	13½	2,100	450	8	5	10	4		

AMPHITRITE. MIANTONOMOH. PURITAN
MONADNOCK. TERROR.

Double-turreted, low-freeboard monitor vessels. No overhang. Turrets suspended on a central spindle on the Ericsson system. Resting normally on their bases, but elevated for re-

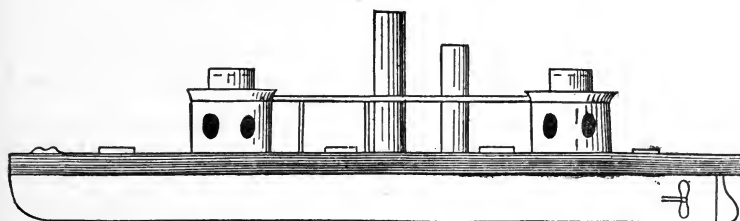

MIANTONOMOH.

volving by means of hydraulic presses. Conning tower on top of each turret. Light flying deck between the turrets, with a ventilating shaft rising just abaft the smoke-stack. Twin screws.

THE FIFTEEN SINGLE-TURRETED MONITORS.

Old-type, single-turreted, low-freeboard monitors. All except the Dictator have an overhang. In some the turrets are

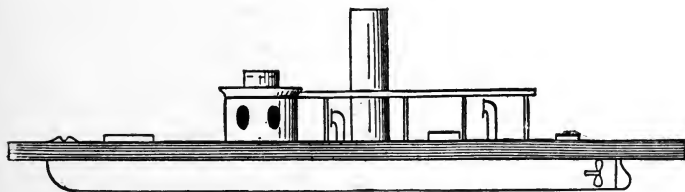

PASSAIC.

raised by driving wedges under the spindle; in others by hydraulic presses. Conning tower on top of the turret. Laminated plating.

INTREPID.

Armored torpedo vessel. Ram bow, round stern, twin screws, partial sail-power. The armored belt, made up of five inches of laminated plating, encircles the water-line to the height of the upper-deck beams. The lower part of the smoke-stack is protected by a belt of nine inches of laminated plating.

The deck is made up of two $\frac{3}{4}$ -inch thicknesses of plate covered by a wooden deck. The pilot-house forward is musket-proof. The hull is of iron, with a wood backing to the armor of eleven

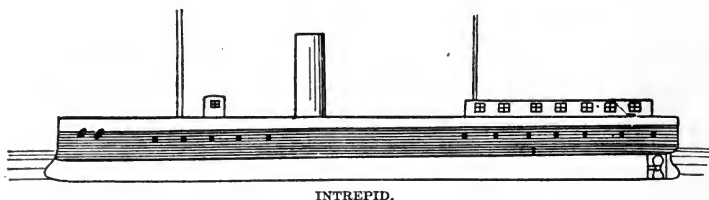

inches. Aft is a light wooden superstructure, forming quarters for officers. The vessel carries no guns and is provided with torpedo-spars (one forward and four broadside).

ALARM.

Partially armored torpedo gun-boat. Ram bow, pointed stern. Mallory steering-screw ; no sail-power. The bow of the vessel is provided with an armored traverse of four inches thickness, the remainder of the hull being unprotected. One 15-inch smooth-bore is carried forward, firing only straight ahead.

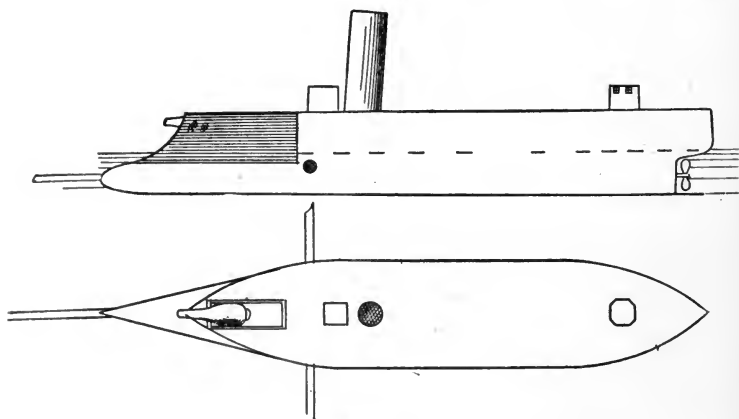

It is the intention to replace this by a 10-inch rifle. The hull is of iron and double, with cellular compartments and water-tight compartments in addition. Three torpedo-spars are projected. One from the snout of the ram a distance of 30 feet, and one from each beam 17 feet. Musket-proof pilot-house aft. Steel $\frac{3}{8}$ -inch deck-plate under a wooden deck.

UNITED STATES.

UNITED STATES GENERAL-SERVICE FLEET.

TYPE AND NAME.	Length between Perpendiculars.		Breadth of Beam.		Maximum Draft.		Displacement.		Indicated Horse- power.		Maximum Speed.		Date of Launch.		BATTERY.
	Ft.	In.	Ft.	In.	Ft.	In.	Tons.	Cu. Ft.	Horse-power.	Knots.	Year.	Month.	Day.		
Frigates.	Colorado.....	264	53	23 $\frac{1}{4}$	4,772	997	9	1855	I 11-inch, XLII 9-inch, II 100-pdrs., II 20-pdrs.						
	Franklin.....	270	54	25 $\frac{1}{2}$	5,162	2,000	10	1865	I 11-inch, XXXVIII 9-inch, IV 100-pdrs.						
	Minnesota.....	265	51	24	4,833	993	9	1855	{ I 11-inch, XLII 9-inch, II 100-pdrs.						
	Wabash.....	262	51	23 $\frac{1}{2}$	4,774	1,039	10	1855							
	Tennessee.....	335	45	22 $\frac{1}{2}$	4,105	2,500	10	1865	II 11-inch, XX 9-inch.						
	Lancaster.....	236	46	19	3,391	2,000	9	1858	{ II 11-inch, XVIII 9-inch, II 60-pdrs.						
	Brooklyn.....	233	43	19	2,686	705	9	1858							
	Pensacola.....	231	45	20	2,852	2,000	10	1858	II 11-inch, XVI 9-inch, II 20-pdrs.						
	Hartford.....	225	41	18	2,826	636	8	1858	XII 9-inch, II 100-pdrs., I 20-pdrs.						
	Richmond.....	225	43	17	2,604	2,000	9	1858	XI 8-inch, II 20-pdrs. Rifles.						
Trenton.....	253	48	21 $\frac{3}{4}$	3,900	3,500	13	1876	{ I 11-inch, XIV 9-inch, II 100-pdrs.							
Powhatan.....	18 $\frac{3}{4}$	3,980	1,500	10	1850								
Alaska.....	251	38	17 $\frac{1}{2}$	2,304	1,150	12 $\frac{1}{2}$	1868	{ I 11-inch, X 9-inch, I 60-pdr., II 20-pdrs.							
Benicia.....	251	38	17 $\frac{1}{2}$	2,304	1,150	9	1868								
Omaha.....	251	38	17 $\frac{1}{2}$	2,394	1,150	12 $\frac{1}{2}$	1868								
Plymouth.....	251	38	17 $\frac{1}{2}$	2,394	1,150	12 $\frac{1}{2}$	1868								
Corvettes.															

UNITED STATES GENERAL-SERVICE FLEET—(CONTINUED.)

TYPE AND NAME.	Length between Perpendiculars.		Breadth of Beam.	Maximum Draft.	Displacement.	Indicated Horse-power.	Maximum Speed.	Date of Launch.	BATTERY.
	Ft.	Ft.							
(Lackawanna.....)	234	38	17½	2,526	1,304	9½	1862	II 11-inch, VIII 9-inch, II 20-pdrs.	
Ticonderoga.....)	234	38	17½	2,526	1,304	12	1862	II " VIII " I 60-pdr., II 20-pdrs.	
Canandaigua.....)	225	38	15	2,128	1,304	8¾	1862	II " VIII " II 20-pdrs.	
Monongahela.....)	225	38	17½	2,078	1,304	8½	1863	II " VIII " I 60-pdr.	
Shenandoah.....)	225	38	17½	2,070	1,304	8½	1863	II " VIII " I " II 20-pdrs.	
Juniata.....)	205	38	16	1,934	1,304	8	1861	{ I 11-inch, VI 9-inch, I 60-pdr.	
Ossipee.....)	205	38	17½	1,934	1,304	8	1862	{	
Quinnebaug.....)	216	30	11¾	1,113	1,132	11½	1875	I 8-inch, I 60-pdr. (rifles), VI 9-inch.	
Swatara.....)	216	30	13	1,113	1,132	11½	1873	I 11-inch, VI 9-inch, I 60-pdr.	
Galena.....)	216	32	18	1,900	1,132	12½	1877	{	
Vandalia.....)	220	38	17½	2,080	1,132	12½	1874	{ I 11-inch, VI 9-inch, I 60-pdr.	
Marion.....)	220	38	18	1,900	1,132	12½	1873	{	
Mohican.....)	216	30	18	1,900	1,132	12½	Building		
(Iroquois.....)	199	34	11¾	1,488	813	11½	1858	II 11-inch, IV 9-inch, III 20-pdrs.	

Corvettes.

Wachusetta.....	190	34	12½	1,488	717	10	1861	II 11-inch, IV 9-inch, I 60-pdr.
Wyoming.....	199	33	11	1,475	717	9¾	1858	II " IV " I 30-pdr.
Tuscarora.....	199	33	13¾	1,457	717	9	1862	} II 11-inch, IV 9-inch, II 20-pdr.
Kearsarge.....	199	34	12¼	1,461	822	9¾	1862	
Adams.....	185	35	16½	1,375	800	11½	1874	} I 11-inch, IV 9-inch, I 60-pdr.
Alliance.....	185	35	16	1,375	800	11½	1875	
Essex.....	185	35	16¼	1,375	800	10½	1874	} I 11-inch, IV 9-inch, I 60-pdr.
Enterprise.....	185	35	16	1,375	800	11½	1874	
Nipsic.....	185	35	12½	1,375	800	11½	1878	} II 11-inch, IV 9-inch, II 20-pdrs.
Narragansett.....	1,235	1,000	9½	1858	
Alert.....	175	28	13¾	1,020	560	9½	1874	} I 11-inch, II 9-inch, I 60-pdr.
Ranger.....	175	28	13½	1,020	560	9½	1874	
Kansas.....	180	30	13½	900	670	9½	1864	} IV 8-inch, II 60-pdrs., II 20-pdrs.
Saco.....	180	30	13½	900	670	9½	1865	
Shawmut.....	180	30	13½	900	670	9	1865	} VIII 20-pdrs. Howitzers.
Yantic.....	180	30	13¾	900	670	9½	1878	
Ashuelot.....	1,370	1,468	8	1864	} VIII 20-pdrs. Howitzers.
Monocacy.....	1,370	1,468	8	1861	
Michigan.....	685	750	9	1844	} VIII 20-pdrs. Howitzers.
Rio Bravo.....	6	Purchased	
Alarm.....	173	28	11	720	800	11	1873	I 15-inch.
Intrepid.....	170	35	12	1,123	800	9	1874	No guns.

Corvettes.

2d Class Corvettes.

Paddle Steamers.

Torpedo Vessels.

UNITED STATES GENERAL-SERVICE FLEET—(CONTINUED.)

TYPE AND NAME.		Displacement.	TYPE AND NAME.		Displacement.
		Tons.			Tons.
Gun-boats.	Palos.....	306	Gun-boats.	Pinta.....	306
	Dispatch.....	730		Speedwell.....	306
	Fortune.....	306		Triana.....	306
	Mayflower.....	306		Standish.....	306
	Leyden.....	306		Catalpa.....	191
	Nina.....	306		Pilgrim.....	168

These Gun-boats are at present unarmed, and, with the exception of the Palos and Dispatch, are used as Tenders at dock-yards. The Palos is in service in China; the Dispatch is in service as a cruising gun-boat.

TENNESSEE.

Iron-braced, wooden, rapid steam frigate. Straight bow, strengthened and provided with a bronze ram; round stern, single screw, full sail-power. No heavy bow-fire.

TRENTON.

Iron-braced, wooden, first-class corvette (second-rate frigate). Ram bow, round stern, single screw, full sail-power. Bow-fire fully developed from four 8-inch rifles. Bower and sheet chains coming in on the berth-deck, leaving the forward part

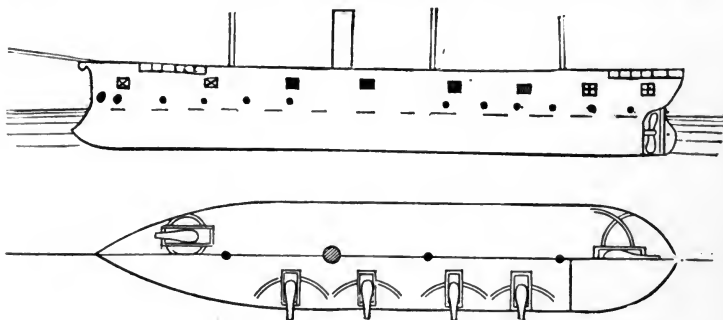

TRENTON.

of the gun-deck clear for working the forward guns. Gun-deck battery of eight 8-inch rifles in broadside; spar-deck battery, two 8-inch pivot-guns forward giving bow and beam fire, and one 8-inch pivot-gun aft giving stern and beam fire.

POWHATAN.

Old-fashioned wooden paddle-wheel frigate.

ASHUELOT.

MONOCACY.

Iron, paddle-wheel, double-ender corvettes. These vessels were originally provided with a rudder at each end, but the forward one is removed. They can carry in addition to their

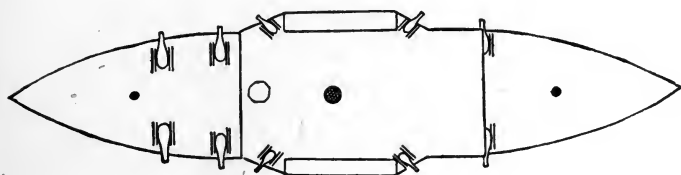
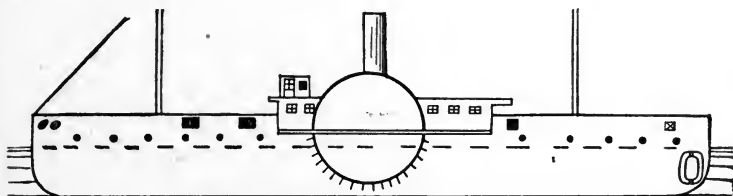

ASHUELOT.

present armament one 11-inch pivot forward and one 11-inch pivot aft. Musket-proof pilot-house on the hurricane-deck.

MICHIGAN.

Old-fashioned iron, paddle-wheel gun-boat carrying a battery of boat-guns.

RIO BRAVO.

Light-draft river steamer carrying a battery of boat-guns. (Purchased.)

DESPATCH.

Rapid despatch vessel carrying a battery of boat-guns. (Purchased.)

The remainder of the fleet is made up of the ordinary general-service type of corvettes and gun-boats.

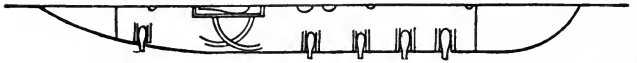
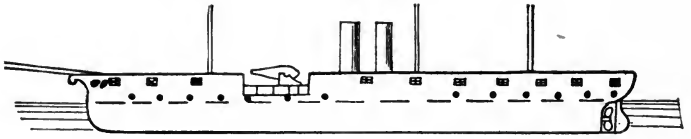

ALASKA.

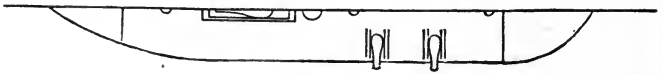
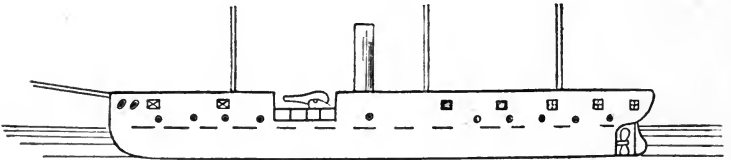

ESSEX.

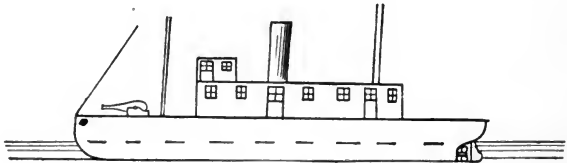

PINTA.

THE PRINCIPAL
NAVAL BATTLES OF TWENTY YEARS.

1860-1880.

- I. BOMBARDMENTS OF EARTHWORKS.
- II. BOMBARDMENTS OF MASONRY FORTS.
- III. PASSAGES OF FORTS.
- IV. DASHES.
- V. ASSAULTS.
- VI. DELIBERATE GENERAL ACTIONS.
- VII. IRON-CLADS AGAINST WOODEN VESSELS.
- VIII. DUELS.

$v = 1.19867$

THE PRINCIPAL
NAVAL BATTLES OF TWENTY YEARS.

1860-1880.

BOMBARDMENTS OF EARTHWORKS.

Earthworks at Hatteras Inlet, August 28 and 29, 1861.

FEDERAL.

WOODEN SQUADRON.

	Guns.		Guns.
Minnesota	46	Pawnee	15
Wabash	45	Monticello	6
Susquehanna	17	Harriet Lane	5
Sailing Corvette Cumberland.	24		

CONFEDERATE.

Fort Clark.—Water-battery mounting 5 guns.

Fort Hatteras.—Earthwork mounting 20 guns.

Early on the morning of the 28th, the Wabash, with the Cumberland in tow, led in to attack Fort Clark, followed by the Minnesota and later by the Susquehanna. This battery was bombarded for three hours, the ships passing and repassing, when it was deserted and not reoccupied. The remainder of the squadron were employed during the forenoon landing troops, but owing to the rough surf only landed 300 men, who occupied and raised a flag on Fort Clark, but took no part in the action at any time. Late in the afternoon fire from the whole fleet was opened on Fort Hatteras and continued for two hours, when the ships drew out of action for the night. At 8 a.m. next day, the frigates led in and opened the engagement, continuing it for three hours, when Fort Hatteras surrendered. Six hundred and seventy prisoners were taken in addition to the forts with their armaments. The gun-boats were slightly injured, and four or five men wounded.

Loss of the Confederates unknown beyond 18 wounded prisoners.

Earthworks at Hilton Head, November 7, 1861.

FEDERAL.

MAIN SQUADRON.

	Guns.		Guns.
Wabash	45	Unadilla	6
Susquehanna.....	17	Ottawa.....	5
Mohican.....	7	Pembina.....	4
Seminole.....	6	Vandalia.....	22
Pawnee	15	(In tow of a light gun-boat.)	

FLANKING SQUADRON.

Bienville.....	11	Penguin.....	9
Seneca	4	Augusta.....	10
Curlew.....	6		

CONFEDERATE.

Fort Walker.—II 6-inch rifles, XII 32-pdrs. I 10-inch, II 8-inch, III 7-inch, I 42-pdr., II 12-pdrs., smooth-bores = 23 guns.

Fort Beauregard.—VIII 32-pdrs., I 6-inch rifle, V 42-pdrs., I 10-inch, I 8-inch, II 24-pdrs., II 6-pdrs. = 20 guns.

At 8.30 a.m. the main squadron formed in line ahead, and passing in between the forts turned towards Fort Walker, delivering their broadsides as they passed within 600 yards. Turning, they passed Fort Beauregard (across the channel and two miles from Fort Walker), delivering broadsides. On the third time passing Fort Walker, it was deserted and taken possession of. Fort Beauregard had been silenced sooner and was taken possession of in the afternoon. The flanking squadron had been sent to attack a flotilla of Confederate gun-boats, which retreated up the river; they then took part in the general engagement. Federal loss, 8 killed, 23 wounded. Duration of action, five hours.

Earthworks on the Mississippi, February 6, 1862.

FEDERAL.

VAN DIVISION—IRON-CLAD GUN-BOATS.

	Guns.		Guns.
Cincinnati.....	13	Carondelet.....	13
Essex	7	St. Louis.....	13

REAR DIVISION—WOODEN GUN-BOATS.

	Guns.		Guns.
Conestoga.....	7	Lexington.....	7
Taylor.....	7		

CONFEDERATE.

Fort Henry.—Twenty guns, mostly of heavy calibre.

The squadron advanced in two divisions, line abreast, the iron-clads leading, and opened fire at 1700 yards, slowing down and approaching to 600 yards. Stopping at this position, the action continued for an hour and a quarter, when the fort surrendered. During this engagement the Cincinnati was struck 31 times, Essex 15 times, St. Louis 7 times, Carondelet once. Casualties, 2 killed, 37 wounded, of whom 28 were scalded by the steam from the boiler of the Essex, which was pierced.

Earthworks at Roanoke Island, February 7, 1862.

FEDERAL.

GUN-BOAT FLEET.

	Guns.		Guns.
Stars and Stripes.....	5	Whitehead.....	1
Louisiana.....	5	Seymour.....	2
Hetzel.....	2	Shawsheen.....	2
Underwriter.....	4	Lockwood.....	3
Delaware.....	3	Ceres.....	2
Valley City.....	5	Putnam.....	1
Southfield.....	4	Brincker.....	1
Hunchback.....	4	Granite.....	1
Morse.....	2		

CONFEDERATE.

Fort Bartow.....	8	Fort Ellis.....	4
" Blanchard.....	4	" Forrest.....	9
" Huger.....	12	Park Point water-battery....	3

Eight light gun-boats mounting 17 guns.

The Federal fleet had convoyed a squadron of army transports carrying 17,000 men, for the purpose of landing them and then silencing the batteries so that they could be captured by the troops. The fleet, having taken up an irregular position owing to the shallow water, opened fire at 11 a.m. At 3 p.m. the landing of troops was commenced and was completed before dark, when the fleet ceased firing. At daylight on the

8th firing was recommenced. At 1 p.m. a row of obstructions across the channel was broken through and the Confederate gun-boats were driven up the river. By 3 p.m. the works were all silenced and in the hands of the troops.

Loss, 6 killed, 17 wounded, eight of the latter by the explosion of a rifled 80-pdr.

Earthworks on the Mississippi, February 14, 1862.

FEDERAL.

IRON-CLAD GUN-BOATS.

	Guns.		Guns.
St. Louis.....	13	Louisville.....	13
Carondelet.....	13	Pittsburg.....	13

WOODEN.

Taylor.....	7	Conestoga ...	7
-------------	---	---------------	---

CONFEDERATE.

Fort Donelson.—A triple row of earthworks, one behind and above the other, mounting in all 20 guns.

The gun-boats advanced in two divisions, line abreast, at 3 p.m., and opened fire at 600 yards, holding their position for an hour and a half, when they drifted out of action disabled, having only silenced the water-battery: 10 killed, 44 wounded. The steering-gear of the St. Louis and the Louisville was shot away, and the other vessels were forced out of action on account of shots between wind and water.

Earthworks on the James River, May 15, 1862.

FEDERAL.

IRON-CLADS.

	Guns.		Guns.
Galena.....	6	Monitor.....	2

WOODEN.

Aroostook.....	6	Naugatuck.....	6
Port Royal.....	6		

CONFEDERATE.

Fort Darling.—A strong earthwork, built on a perpendicular bluff about 200 feet above the river, mounting 14 heavy guns.

The iron-clads moved up to within 600 yards, which was as close as they could come and reach the fort with their guns.

CARONDELLET.

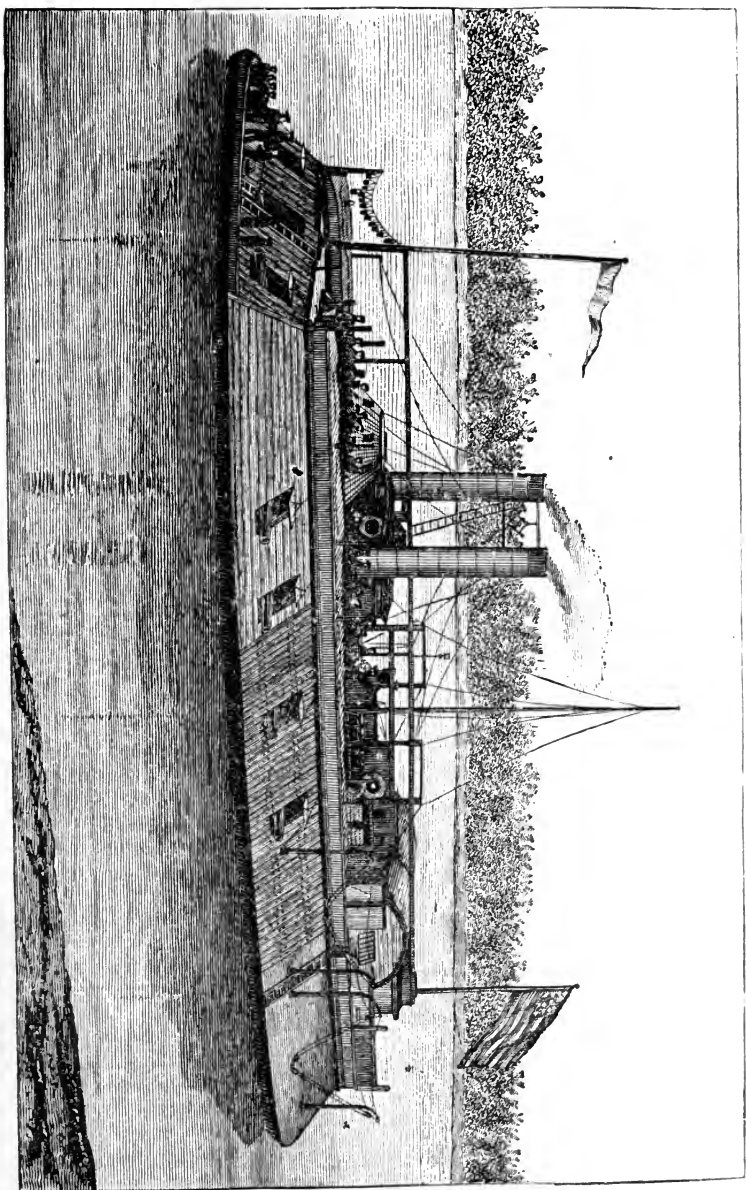

United States Iron-clad River Gun-boat, used with great success during the Civil War.

The wooden vessels came to within about 1400 yards and the squadron anchored, and, springing their broadsides on the fort, opened fire. The action continued four hours, when the ammunition of the Galena giving out and no impression having been made on the fort, the squadron drew out of action: 13 killed, 14 wounded. All the casualties except two wounded happened on board the Galena, an experimental iron-clad. She was so much cut up that her armor was removed and she was made a wooden gun-boat. The Monitor was uninjured.

Earthworks at Fort Hindman, January 10 and 11, 1863.

FEDERAL.

IRON-CLAD GUN-BOATS.

	Guns.		Guns.
Louisville.....	13	Lexington.....	7
Baron de Kalb.....	13	Black Hawk.....	6
Cincinnati.....	13	Rattler.....	6

CONFEDERATE.

Fort Hindman, Arkansas River.—A quadrangular earthwork, mounting 10 guns, two of the heaviest being in armored casemates.

At 5 p.m. of the 10th, the Louisville, De Kalb, and Cincinnati moved up in line abreast to within 400 yards and opened fire. As soon as the fire of the forts slackened the Lexington and Black Hawk moved up and opened with shrapnel, while the Rattler passed up the river and took the fort in enfilade. Ceased firing and drew out of action at dark. In the morning the attack was renewed in the same manner, and the fort surrendered in four hours. Casualties, 5 killed, 23 wounded. The two casemates were completely shattered and every gun dismounted.

Earthworks at Grand Gulf, April 29, 1863.

FEDERAL.

IRON-CLAD GUNBOATS.

	Guns.		Guns.
Louisville.....	13	Tuscumbia.....	5
Carondelet.....	13	Benton.....	16
Mound City.....	13	Lafayette.....	6
Pittsburg.....	13		

CONFEDERATE.

Grand Gulf Batteries, Mississippi.—Consisting of one fort 75 feet high, mounting four heavy rifles, and one fort farther down the river mounting four heavy rifles.

The Louisville, Carondelet, Mound City, and Pittsburg moved down in line ahead and attacked the lower battery, silencing it an hour, and then moved up to the support of other vessels against the upper one. The action continued five hours and a half, and the batteries being silenced the flotilla drew out of action, expecting the army to assault and take possession. This was not done, and the next day the flotilla was ordered to attack again. The batteries were both found deserted and the guns spiked, except three which had been dismounted by the firing. Casualties: Lafayette, 1 wounded; Benton, 7 killed, 12 wounded; Louisville, none; Tuscumbia, 5 killed, 24 wounded; Mound City, none; Carondelet, none; Pittsburg, 6 killed, 12 wounded. The Benton was hit 47 times; 12 shots pierced the $\frac{3}{4}$ -inch armor, 4 shots pierced the $2\frac{1}{2}$ -inch casemate armor, and 1 shot pierced the $1\frac{1}{2}$ -inch armor of the pilot-house. Louisville hit 7 times, Tuscumbia 81 times, Pittsburg 35 times.

Earthworks at Simonoseki, July 11, 16, and 20, 1863, and September 5, 1864.

These attacks were made by vessels of different nationalities on a series of earthworks lining the narrow straits of Simonoseki, Japan. July 11, the Dutch corvette Medusa entered the straits, and being fired at opened fire on the batteries at a distance of 1200 yards. The action continued one hour, when the Medusa drew out without having silenced the batteries. Casualties, 4 killed, 5 wounded.

On the 10th, the United States corvette Wyoming entered the straits, and on being fired at opened a return fire. Passing between two sailing gun-boats on one side and a steam gun-boat on the other at pistol-shot distance, she gave them both broadsides, sinking the sailing vessels and blowing up the boiler of the steamer. Action continued an hour and a half, when the Wyoming drew out without silencing the batteries. Casualties, 4 killed, 7 wounded.

On the 20th, the French frigate Semiramis and corvette Tancredè entered the strait, and on being fired at returned the fire. The first broadside blew one of the earthworks to pieces. In two hours the forts were silenced, and a landing party spiked the guns and blew up the magazine.

On the 5th of September, 1864, an allied squadron of English, French, Dutch, and American vessels, 16 in number, mounting 200 guns, and carrying 3500 men, anchored in the straits and opened fire on the batteries. The batteries were silenced and deserted in about two hours. The next day a force

of 2600 men was landed, the guns were spiked and the fortifications were dismantled. Casualties, 12 killed, 60 wounded.

Earthworks at Kagosima, August 15, 1863.

ENGLISH.

	Guns.		Guns.
Euryalus.....	35	Race-horse.....	4
Pearl.....	24	Havoc.....	2
Perseus.....	17	Coquette.....	2
Argus.....	6		

JAPANESE.

KAGOSIMA DEFENCE.

One fort containing four guns.
One fort containing twenty guns.

The corvettes advanced in line ahead on the four-gun battery, delivering their broadsides as they passed, silencing the fort and leaving it to the care of the gun-boats. Passing on to within 1200 yards of the twenty-gun battery they bombarded it for six hours, having to contend with a typhoon at the same time. During the action the city of Kagosima was accidentally set on fire and nearly half of it was burned. The fort was not silenced at dusk, when the squadron hauled out of action, but the next morning the Japanese came to terms before the attack was renewed.

Earthworks off Charleston Harbor, July 18 and August 17, 1863.

FEDERAL.

INNER LINE—IRON-CLADS.

	Guns.		Guns.
Montauk.....	2	Nantucket.....	2
New Ironsides.....	20	Weehawken.....	2
Catskill.....	2	Patapsco.....	2

OUTER LINE—WOODEN GUN-BOATS.

Paul Jones.....	9	Chippewa.....	6
Ottawa.....	5	Wissahicken.....	4
Seneca.....	4		

CONFEDERATE.

Fort Wagner.—A strong earthwork, containing 10 heavy guns, and supported by three 4-gun water-batteries.

On the 18th of July the iron-clads moved in in line, taking up a position abreast the fort and within 1200 yards, the gun-

boats firing at long range. At 4 p.m., the tide serving, the iron-clads moved in to 400 yards and completely silenced the fort. Drew out of action at dark, the object of silencing the battery being accomplished. On August 17th the iron-clads moved in abreast the fort to within 450 yards, and silenced the fort in two hours. Drew out of action at noon, the object having been accomplished.

Earthworks at Fort McAllister, March 3, 1863.

FEDERAL.

MONITORS.

	Guns.		Guns.
Passaic.....	2	Nahant.....	2
Patapsco.....	2		

CONFEDERATE.

Fort McAllister.—A strong earthwork containing seven heavy guns and one 11-inch mortar.

This attack was intended as a test of the strength of monitors to resist a heavy fire. The monitors moved up in line ahead and opened fire, continuing the action for eight hours at a distance of 1200 yards. The forts were not silenced. The Passaic was hit 9 times on the side-armor, no damage; 13 hits on the deck-plating, the deck being crushed through in three places; 5 hits on the turret, no damage; 2 on the pilot-house, no damage; 1 on the roof of the turret, breaking a beam; 4 through smoke-stack—34 hits in all; none killed or wounded.

Patapsco one hit on deck; no injury. Nahant no hits.

Earthworks at Fort Fisher, December 24 and 25, 1864, and January 13 and 14, 1865.

FEDERAL.

FIRST LINE—IRON-CLADS.

	Guns.		Guns.
New Ironsides.....	20	Saugus.....	2
Canonicus.....	2	Mahopac.....	2
Monadnock.....	4		

WOODEN GUN-BOATS.

	Guns.		Guns.
Nyack.....	8	Pontoosuc.....	6
Unadilla.....	6	Nereus.....	2
Huron.....	4	Kansas.....	8
Pequot.....	8		

SECOND LINE—FRIGATES.

	Guns.		Guns.
Wabash.....	45	Colorado.....	45
Powhatan.....	19	Minnesota.....	46
Susquehanna.....	18		

CORVETTES.

	Guns.		Guns.
Juniata.....	11	Tuscarora.....	10
Shenandoah.....	10	Mohican.....	7
Brooklyn.....	26	Vanderbilt.....	15
Ticonderoga.....	10		

GUN-BOATS.

	Guns.		Guns.
Seneca.....	4	Maumee.....	4
Pawtuxet.....	4	Yantic.....	5
Mackinaw.....	12		

ADVANCED SQUADRON OF SECOND LINE—GUN-BOATS.

	Guns.		Guns.
Monticello.....	7	Osceola.....	8
Rhode Island.....	11	Tacony.....	6
Sassacus.....	6	St. Jago de Cuba.....	10
Chippewa.....	6	Fort Jackson.....	6

RESERVE LINE—GUN-BOATS.

	Guns.		Guns.
Aries.....		Keystone State.....	13
Howquah.....		Banshee.....	
Wilderness.....		Emma.....	
Cherokee.....		Lilian.....	
Vance.....		Nansemond.....	
Anemone.....		Tristram Shandy.....	
Moccasin.....		Britannia.....	
Eolus.....		Bignonia.....	
Gettysburg.....		Governor Buckingham.....	

CONFEDERATE.

Fort Fisher and a range of isolated batteries containing 36 guns, about one half being rifles.

At daylight the fleet steamed in in lines ahead, the first line anchoring abreast the sea-face of the fort within 1300 yards, the second line abreast the salient of the works at 1700 yards, the advanced second line abreast the land-face attacking the outworks; the reserve, out of fire, outside of the second line. The fort was completely silenced in an hour and a quarter. Fire was kept up all day, and 3000 troops were disembarked, but returned without attempting an assault. The enemy's fire was silenced so quickly that not a person was injured in the fleet. Six 100-pdr. rifles exploded in the fleet, killing 16 and wounding 23. Three gun-boats were partially disabled by the fire from the fort, but went into action next day. On the 25th the same positions were taken by the lines and the fort was silenced in one hour. On January 13th the same positions were taken and the fort was silenced in three hours. Fire was kept up all day, and 8000 troops were landed in three hours. January 15th the same positions were taken, and the fort was silenced in one hour. (For remainder of action of 15th, see *Assaults*.) During these bombardments, every gun on the sea-face (19) was dismantled or disabled.

Earthworks on the Danube, May 6, 1877.

The Turkish double-turreted monitor Luft-i-Dyelil attacked a water-battery on the Danube at a distance of 1800 yards. The Russians replied with rifled field artillery. After an action of one hour the monitor received a shot through her boiler, which blew up and sank the ship. All but one man lost.

Earthworks at Callao, May 2, 1866.

SPANISH.

ONE IRON-CLAD FRIGATE, FIVE WOODEN FRIGATES, ONE WOODEN GUN-BOAT.

	Guns.		Guns.
Numancia.....	33	Villa de Madrid.....	52
Blanca.....	25	Almansa.....	38
Resolucion.....	25	Vencedora.....	3
Berenguela.....	16		

PERUVIAN.

Defences of Callao.—Range of earthworks containing XV 32-pdrs., VI 60-pdrs., IV 9-inch rifles, II iron revolving turrets, IV 9-inch, II light-draft monitors, II 6-inch rifles.

The fleet divided into three divisions for the attack of different parts of the line of fortifications, and went into action in line ahead at noon, taking positions at about 1600 yards' distance and maintaining an action of four hours, when the squadron drew out of action, not having silenced the forts. One battery only silenced through the bursting of a gun. Casualties in the fleet, 38 killed, 150 wounded. The Villa de Madrid was disabled early in the action by a shot through her boiler. The Resolucion was disabled by a shot through the water-line. Admiral Nuñez wounded.

RÉSUMÉ.

Total number of earthwork attacks noted, 21.

COMPLETE SUCCESS—8. Hatteras Inlet, Hilton Head, Fort Henry, Roanoke Island, Fort Hindman, Grand Gulf, French at Simonoseki, Allies at Simonoseki.

PARTIAL SUCCESS—6. Kagosima, Fort Wagner, three attacks on Fort Fisher, second attack on Fort Wagner.

FAILURES—7. Fort Donelson, Fort Darling, Dutch at Simonoseki, Americans at Simonoseki, Fort McAllister, Danube forts, Callao.

Of the partial successes, all six accomplished the objects of the bombardment. In that of Kagosima the Japanese were brought to terms, and the other five had for their object to silence the forts, which they accomplished.

Of the failures, the two attacks on Simonoseki were retaliatory measures, and would probably have succeeded had they been kept up longer. Fort Darling and Fort McAllister were experimental tests, although there are no grounds to believe that the forts would have been silenced had the action been kept up longer. At Fort Donelson, the Danube forts, and Callao the ships were beaten.

BOMBARDMENTS OF MASONRY FORTS.

Attack on Fort Sumter, April 7, 1863.

FEDERAL.

IRON-CLAD SQUADRON.

	Guns.		Guns.
Weehawken	2	Catskill.....	2
Passaic	2	Nantucket.....	2
Montauk	2	Nahant.....	2
Patapsco	2	Keokuk	2
New Ironsides.....	16		

CONFEDERATE.

Fort Sumter, 10 guns, supported by *Fort Moultrie*, 16 guns, and earth-works adjacent mounting 43 guns.

The squadron went into action at 2 p.m. in line ahead, approaching Fort Sumter as close as the obstructions would permit (from 500 to 1000 yards), and opened fire. The action lasted two hours, when the fleet withdrew, not having silenced the fort. The Weehawken was hit 53 times, the side-armor being completely shattered in places, the deck broken through once, 36 turret-bolts broken, and at one time the turret was jammed. The Passaic was hit 35 times; her turret was disabled for a time, and one turret-gun was completely disabled; the pilot-house was knocked almost over. Montauk hit 14 times; no injury. Patapsco hit 47 times; gun disabled. New Ironsides hit *about* 50 times; one port-shutter knocked off, otherwise uninjured. Catskill hit 20 times; deck broken through. Nantucket hit 51 times; port-stopper jammed, disabling one gun. Nahant hit 36 times; turret jammed, side-armor badly shattered. Keokuk (casemated gun-boat) *pierced* at and below the water-line 19 times; turrets pierced and port-shutters knocked away; vessel sank the next day. Casualties: Keokuk, 16 wounded; Nahant, 1 killed, 6 wounded; all by broken bolts flying in the turret or pilot-house.

Attack on Fort Sumter, August 22 and September 1, 1863.

FEDERAL.

IRON-CLAD SQUADRON.

	Guns.		Guns.
Weehawken	2	Passaic.....	2
Montauk	2	Patapsco.....	2
Nahant	2		

CONFEDERATE.

Fort Sumter, supported by *Fort Moultrie*.

Squadron went into action at 3 a.m. within 800 yards of Sumter, keeping up a steady fire for three hours. Only six shots fired from Sumter in return, but a heavy fire kept up from Moultrie. Fleet drew out, not having drawn the fire of Sumter. On the night of September 1st the squadron moved in again and bombarded Sumter for five hours. The fort was almost dismantled, but still kept its garrison. Fort Moultrie responded to the fire. The fleet withdrew, not having driven the garrison from the fort.

Bombardment of Mississippi Forts, April 18 to April 28, 1862.

FEDERAL.

Twenty mortar-schooners, each armed with a single mortar. For about one hour and a half the forts were under the fire of Admiral Faragut's fleet of 17 vessels, mounting 188 guns.

CONFEDERATE.

Fort Jackson.—A masonry fort on the right bank of the Mississippi, mounting 75 guns. *Fort St. Philip*.—A masonry fort on the left bank of the river, nearly opposite Fort Jackson, mounting 80 guns.

On the morning of April 18th the mortar-schooners were towed into position in three divisions. The first and third (14 vessels) were moored near the right bank of the river at a bend below Fort Jackson, within 2800 yards of it, and protected by a thick wood, the mast-heads of the schooners being trimmed with branches to conceal their exact position. The second division was moored near the left bank of the river, more exposed and 3700 yards from Fort Jackson. About 1 p.m. fire was opened from all the mortars on Fort Jackson, and continued without inter-

ruption until sunset. One mortar only was directed against Fort St. Philip. At the end of the first day's bombardment two guns had been dismantled and a third heavy rifle broken in two in Fort St. Philip. The citadel of Fort Jackson was set on fire. On the evening of the 18th the second division was transferred to the right bank, the left one being too much exposed. On the 19th, 20th, 21st, 22d, and 23d the bombardment was continued each day, one mortar-vessel being sunk by a rifled shot from Fort Jackson on the 19th. On the night of the 23d and early morning of the 24th an incessant fire was kept up whilst Admiral Farragut's fleet was passing the forts. On the 25th, 26th, and part of the 27th the bombardment continued, and on the 28th both forts capitulated. Fort Jackson was reduced almost to a ruin, over 800 bombs having fallen in it. Several guns were dismantled and the casemates were cracked through in all directions. Fort St. Philip was not much injured, its fall being a necessary consequence of that of Fort Jackson.

RÉSUMÉ.

Total number of masonry attacks noted, 4. Successful, 1. Failures, 3.

Fort Sumter was, by repeated bombardments for two years, reduced nearly to a total ruin, but was not abandoned until Charleston was captured by General Sherman. Fort Moultrie never was silenced until it was abandoned. Fort Jackson refused to surrender after six days' constant bombardment by a mortar fleet and an hour's bombardment from a passing fleet at from 60 to 300 yards, only capitulating at a second summons, when the capture of New Orleans destroyed the last chance of relief.

PASSAGES OF FORTS.

Passage of Fortifications below New Orleans, April 24, 1862.

FEDERAL.

WOODEN FLEETS.—FIRST DIVISION.

	Guns.		Guns.
Hartford	28	Kennebec.....	4
Brooklyn	26	Pinola	4
Richmond	25	Itasca	4
Sciota	3	Winona	4
Iroquois.....	7		

SECOND DIVISION.

Pensacola.....	26	Varuna.....	6
Mississippi.....	19	Katahdin.....	6
Cayuga.....	6	Kineo.....	6
Oneida.....	10	Wissahickon.....	4

CONFEDERATE.

Fort Jackson, 75 guns. *Fort St. Philip*, 30 guns. Above the forts, two iron-clad rams and eighteen gun-boats. Below the forts, a heavy boom of logs and chain across the river. The river current to be stemmed runs at a speed of about six to seven knots.

On the night of the 22d, two gun-boats were sent up to break the obstructions. The end of the chain was reached and successfully cut under a heavy fire, making an opening wide enough to allow vessels to pass. At 2 a.m. of the 24th the fleet got under way, forming two lines, the first division to take Fort Jackson, and the second Fort St. Philip. The chains were stopped up and down the sides in wake of the boilers; decks were whitewashed and boarding-nettings triced up. Coming under the fire of the forts, the lines were broken owing to the strength of the current and the necessity for feeling the way up in the channel, there being no pilots. The Hartford grounded abreast Fort St. Philip, and whilst in this position a fire-raft was pushed against her, setting her on fire aft. The raft was pushed clear, fire extinguished, and the ship was worked off the shoal. She was hit 32 times; 3 killed, 10 wounded. The Brooklyn fouled the obstructions, and was held for a short time under the fire of Fort St. Philip. Clearing these, she was rammed by the ram *Manassas*, but the blow

was a glancing one. Immediately afterward a gun-boat was seen coming at her full speed. The Brooklyn gave her the port broadside, and disabled her: killed, 9; wounded, 26. Richmond, killed, 2; wounded, 4. Sciota, wounded, 2. Iroquois, killed, 8; wounded, 24. Kennebec fouled the obstructions, and did not get clear until the fleet had passed up; returned to the lower anchorage. Pinola, killed, 3; wounded, 8. Itasca received a shot through her boiler abreast the forts, and drifted down helpless out of action; wounded, 3. The Winona was fouled by the Itasca in getting under way, and did not make the attempt until the fleet had passed, when she was obliged to turn back: killed, 6; wounded, 4. Pensacola, killed, 4; wounded, 33. Mississippi, just after passing the forts, was rammed on the quarter by the Manassas, injured, but not cut through: killed, 2; wounded, 6. Cayuga—the leading vessel in the fight—after passing the forts was attacked by three gun-boats at once: one on the starboard beam she disabled by a broadside; one on the port-bow was driven off by the bow-pivot; one on the port-quarter was taken in hand by the Varuna before she could do harm: wounded, 6. Oneida, just after passing the forts, discovered a gun-boat trying to cross her bow; ran her down and sank her at once: wounded, 3. Varuna, after passing the forts, disabled two gun-boats; was then rammed twice by one gun-boat, and once by another; finding her sinking, her commander ran her ashore, disabling completely both the gun-boats that had rammed him: killed, 3; wounded, 9. Katahdin, uninjured. Kineo, wounded, 8. Wissahickon, uninjured. Total: killed, 37; wounded, 147. The Mississippi, after clearing the fight, was ordered to ram the Manassas, which was seen coming up the river. Running down towards her, the Manassas sheered broad off and ran ashore, receiving two broadsides, which disabled her and set her on fire. She drifted down the river and blew up. Fourteen vessels out of seventeen passed the forts. Of those failing to pass, one was disabled. Of those that passed, one was sunk. Of the Confederate flotilla eleven were captured, and eight—including the ram Manassas—were destroyed. The second ram (Louisiana) did not engage for some reason. Two days afterward, while the flag of truce was flying at the capitulation of the forts, she was set on fire and turned adrift to explode amongst the mortar squadron. She blew up before reaching it.

The fleet that passed the forts went into action on the next day (25th), silenced a line of earthworks, and passing up to New Orleans received its surrender.

Passage of Forts, Mississippi River, June 28, 1862.

FEDERAL.

	Guns.		Guns.
Richmond.....	25	Sciota.....	3
Hartford.....	28	Winona.....	4
Brooklyn.....	26	Pinola.....	4
Iroquois.....	7	Katahdin.....	6
Oneida.....	10	Kennebec.....	4
Wissahickon.....	4		

CONFEDERATE.

Triple line of earthworks at Vicksburg, mounting about 30 guns.

At 4 a.m. the squadron, steaming up the river in double line ahead (large ships inside with the smaller ones abreast the intervals), came under the fire of the enemy at a distance of 600 yards. The rate of steaming was about three miles per hour. Three ships (Brooklyn, Kennebec, and Katahdin) failed to pass. The Brooklyn, getting fouled with the mortar flotilla, was detained, and under a misapprehension of orders stopped to silence the battery, and dropped down after daylight. The Kennebec held her position astern of the Brooklyn. The Katahdin, having no orders at all, followed the motions of the Brooklyn. Casualties in the part of the squadron which passed: killed, 15; wounded, 30. Duration, two hours; distance gone while under fire, three miles.

Passage of Forts, Mississippi River, March 14, 1863.

FEDERAL.

WOODEN SQUADRON.

	Guns.		Guns.
Hartford.....	28	Albatross.....	7
Richmond.....	25	Genesee.....	8
Monongahela.....	14	Kinco.....	6
Mississippi.....	19		

CONFEDERATE.

Earthworks at Port Hudson.—A line of earthworks extending at intervals a distance of about three miles, and mounting 70 guns, most all of heavy calibre.

At 9 p.m. of the 24th, signal was made to weigh anchor and pass the forts up-stream. The vessels except the Mississippi were lashed in pairs (Hartford and Albatross, Richmond

and Genesee, Monongahela and Kineo). The mortar fleet below the forts opened a heavy fire on the works, and two light gun-boats took up an enfilading position and shelled the water-batteries. The Hartford passed up without trouble. The Richmond (slowest vessel in the squadron) reached a bend of the river where she was directly within the cross-fire of the batteries, but could not stem the current even with the help of her tow, so she was obliged to turn and go back. The Monongahela reached the bend and the current forced her ashore for about half an hour; getting off finally she started ahead, but was obliged to stop her engine on account of the heating of the journals; drifted down again out of range. The Mississippi ran aground at the bend, but could not be gotten off. After working for half an hour, her guns were spiked, the ship was fired and deserted, and she blew up. Casualties: killed, 12; wounded, 35; missing, 63. One steam frigate lost.

Passage of Fort Morgan, August 5, 1864.

FEDERAL.

MONITORS.

	Guns.		Guns.
Tecumseh	2	Winnebago	4
Manhattan	2	Chickasaw	4

CORVETTES.

Brooklyn	26	Monongahela	14
Hartford	28	Ossipee	12
Richmond	25	Oneida	10
Lackawanna	14		

GUN-BOATS.

Octarora	10	Kennebec	4
Metacomet	10	Itasca	4
Port Royal	6	Galena	6
Seminole	6		

CONFEDERATE.

Fort Morgan.—A masonry fort containing 30 guns. Iron-clad ram Tennessee (six 7-inch rifles). Gun-boats Selma, Morgan, and Gaines. A line of torpedoes and pile obstructions across the channel.

At 5.30 a.m. the fleet got under way and steamed in in two lines ahead, the four monitors in the starboard line slightly leading and nearest the fort. The port line of wooden ships showed the corvettes towards the fort, with each one having a gun-boat lashed along the port side. The fort opened fire at 7.30, the leading ship (Tecumseh) being within 1400 yards.

Just abreast the fort the Tecumseh fouled a torpedo and was sunk. The Brooklyn (leading the second line) stopped her engines and threw the line into disorder, but the Hartford pushing on ahead restored the line and led the way in, all the ships passing the fort. On clearing the narrow channel, the gun-boats were cast off and gave chase to the Confederate gun-boats, the Metacomet capturing the Selma, the other two vessels escaping under the fort. At 8.45 the fleet was all in the bay beyond the fort. The Tennessee then made a rush at the Hartford, and Admiral Farragut made the signal to attack with

Before the Action.

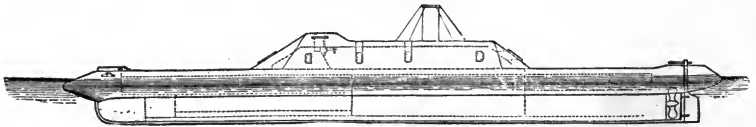

After the Action.

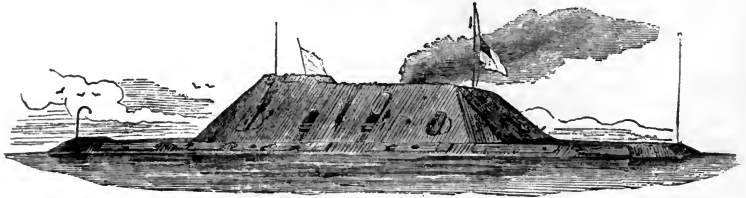

Section through Pilot-House.

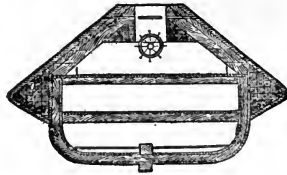

CONFEDERATE RAM TENNESSEE.

guns and rams. The Monongahela struck the ram first, a square blow, making no impression, but breaking off its own ram. The Lackawanna then struck a fair blow with no impression, but staving its own bow. The Hartford then rammed, striking a glancing blow and swinging alongside, giving a full broadside without effect. The Lackawanna and Hartford then bore down together but collided, the Hartford's side being cut down almost to the water's edge by the Lackawanna. The Lackawanna, Monongahela, and Ossipee then bore down at full speed, but sheered off at seeing a white flag hoisted.

During the ramming, the monitors got under the stern of the ram and bombarded her casemate with effect. Casualties: killed, 52; wounded, 170. Monitor *Tecumseh* sunk with all hands except 11. Corvette *Oneida* disabled abreast the fort by a shot through the boiler, but dragged through the action by her consort. The injuries to the bows of the ramming ships and to the *Hartford's* side were not so severe as to at all disable them. Captured, armored ram *Tennessee*, wooden gun-boat *Selma*, 280 prisoners. The steering-gear and smoke-stack of the ram were shot away, the port-shutters were jammed so as to disable the guns, and the ship's frame was racked so as to make her leak, but not badly. The ramming vessels left no marks.

Passage of the Vicksburg Batteries, April 16, 1863.

FEDERAL.

IRON-CLAD GUN-BOATS.

	Guns.		Guns.
Benton.....	16	Pittsburg.....	13
Lafayette.....	6	Carondelet.....	13
Louisville.....	13	Tuscumbia.....	5
Mound City.....	13	General Price.....	2
		Three army transports.	

CONFEDERATE.

Vicksburg Batteries.—47 heavy guns.

The vessels started from up the river in line ahead, with the transports in rear, the *Tuscumbia* acting as rear-guard to prevent the transports turning back when once under fire. Leaving the anchorage at 10.30 p.m., they steamed slowly down until coming within sight of the batteries, when they stopped their engines and drifted. The leading vessel was discovered abreast the first battery and fire was opened. The fleet then started ahead fast returning the fire. Two transports turned and started back, but were driven down again by the *Tuscumbia*, the three vessels suffering severely in the manœuvring, but passing down successfully. Casualties, 12 wounded. Each gun-boat carried a barge-loaded with coal, on the off side. Two barges were sunk, the remainder were carried through safely. One of the transports was disabled, but was taken in tow under fire and brought safely through. Time under fire, one hour.

RÉSUMÉ.

Total number of battles passing fortifications, 5. Successful, 3. Partially successful, 2. Of the latter, one failed on account of a misunderstanding of orders, and one on account of the strength of current rendering the ships unmanageable. In all cases the ships passed the main line of fortifications at a distance of less than 600 yards, and all were subjected to a severe well-aimed fire.

ASSAULTS.

Assault on Fort Sumter, September 8, 1863.

At 10 p.m., September 8th, a landing party of 300 sailors and 100 marines was put in boats, taken in tow by a tug-boat, and towed to within 1000 yards of the breach at Fort Sumter. One division of 20 men was sent to the north-east face to make a feint, while the main body landed at the breach. Through a general misunderstanding the boats went in irregularly, but a few boats' crews landed, and, no support being given, they were captured. The expedition was a total failure, no assault being made. Casualties: 3 killed, 27 wounded, 130 prisoners, 11 missing.

Assault on Fort Fisher, January 15, 1865.

The assaulting column, composed of 1600 sailors and 400 marines, formed about a mile from the face of the fort (the fire of the fort being kept under by a heavy bombardment from the fleet) in four lines. The marines forming the first line, were deployed as skirmishers, and advanced along the beach to a line of rifle-pits and occupied them within 600 yards of the sea-face of the fort. The other three lines advanced by the left flank (parallel to each other) along the beach, reaching the marines, and the column lay down while the fleet shelled the works, the marine line coming abreast the second line of sailors. At the word "Charge," the column rose and charged by the flank to the stockade, extending

from the salient of the fort to the water's edge. Instead of keeping on past the stockade and then charging by the right flank up to the ditch, which would have brought the lines in proper position, the heads of the column turned up at the stockade and became mixed together. The charge was continued to the parapet, but the confusion of the wrong movement caused a break, ending in a panic, and the whole column retreated under a heavy fire from the fort, leaving about 60 men under the protection of the head of the stockade, who entrenched themselves there and stayed until the fort was taken by the troops entering at the other end of the fort. The assault was a failure in everything except as far as deceiving the besieged, who mistook it for the main assault, and thus permitted the 8000 troops at another point to gain a foothold. Casualties: killed, 80; wounded, 228; missing, 22.

Assault on the Corean Forts, June 11, 1871.

The *Monocacy* (10 guns) and *Palos* (4 guns) steamed up the *Salée* River and disembarked a landing party of 546 sailors and 105 marines, taking with them a battery of seven boat-guns. Five forts were to be captured, situated at distances of from half a mile to three miles. The *Monocacy*, taking position abreast the first fort, shelled it vigorously, protecting the landing party and driving the Coreans from the earthworks and stone fort in about one hour. The landing party entered without resistance, capturing and destroying two 32-pdrs., six 18-pdrs., and twenty smaller pieces, 2 and 4 pdrs. The advance stopped for the night, the landing party going into camp outside of the fort. At daylight of the 11th the advance recommenced, the *Monocacy* keeping abreast and shelling the Coreans out of the second fort, which was occupied and dismantled. The citadel about three miles farther up the river was the next point to be captured, and had to be taken by assault. Marching to the crest of a hill within 150 yards of the citadel, the storming party were ordered to lie down for a rest, the skirmishing line of marines keeping up a fire on the parapet. A detachment of men and guns was sent to occupy a commanding position and hold a large body of Coreans in check that was forming in rear, while another detachment was sent to cut off the retreat from the citadel. A deep ravine lay between the storming line and the fort, and the walls of the citadel were twelve feet high, the only entrance being through a small breach made by the fire of the *Monocacy*. The citadel was stormed, and a foothold gained without a halt, and after a hard hand-to-hand fight,

was captured. With the fall of the citadel the other forts were abandoned, whilst the detachment commanding the road of retreat of the Coreans put them under a severe fire. The assault was a complete success. Loss of the Coreans: killed, 243; wounded, unknown; prisoners, 22; five stone forts and 481 pieces of ordnance, comprising eleven 32-pdrs., fourteen 24-pdrs., two 20-pdrs., and the remainder 2 and 4 pdrs.; fifty flags, including the standard of the Generalissimo. Loss of United States: killed, 3; wounded, 10.

RÉSUMÉ.

Number of assaults noted, 3. Failures, 2. Success, 1. Of the failures, the first was too hastily planned to even make a commencement. Everything was confusion from the time that the boats were cast off from their tows. The second was primarily due to confusion of the assaulting columns at the most critical moment, followed by a panic.

DELIBERATE GENERAL ACTIONS.

Gun-boat Flotillas in the Mississippi, June 5, 1862.

FEDERAL.

IRON-CLAD GUN-BOATS.

	Guns.		Guns.
Benton	13	Cairo	13
Louisville	13	St. Louis	13
Carondelet	13		

RAMS.

Queen of the West	2	Monarch	2
-------------------------	---	---------------	---

CONFEDERATE.

IRON-CLAD GUN-BOATS.

	Guns.		Guns.
Lovell		Little Rebel	
Beauregard		Sumter	
Price		Bragg	
Thompson		Van Dorn	

On the morning of June 5th, the Federal flotilla descending the river discovered the Confederate flotilla moored at the city of Memphis. The latter formed in double line abreast below the city, and received the attack. The Queen of the West, dashing from the Federal line, rammed the Lovell and sank her at once. In getting clear she was rammed by the Beauregard and seriously injured, though not disabled. The Beauregard was rammed by the Monarch, and at the same time received a shot through her boilers which disabled her; she drifted near the bank of the river and sank. The Price was accidentally rammed and sunk by one of her own flotilla. The Little Rebel was disabled by shot, run ashore and abandoned. The Thompson was set on fire by shells and blown up. The Sumter was captured. The Bragg was rammed and sunk. The Van Dorn escaped down the river. Result: one Federal ram partially disabled; no killed, no wounded. Four Confederate gun-boats sunk, one captured, one blown up, one deserted, and one escaped. Killed and wounded unknown, but many lost by drowning and scalding. Duration of action, twenty minutes.

In this fight the Federal fleet had the advantage of fighting down stream, being the ones to make the onset, and having the heavier vessels and batteries. The Confederates took no advantage of the weak steaming powers of the Federal gun-boats. Had they passed up stream, re-formed, and forced the Federals to act on the defensive and fight up stream, the result might have been different. Decisive action.

Battle of Helgoland, May 9, 1864.

DANISH SQUADRON.

	Guns.		Guns.
Niels Juel	42	Heimdal.....	16
Jylland	44		

AUSTRIAN SQUADRON.

	Guns.	
Schwartzenburg.....	48	Three Prussian gun-boats.
Radetzky.....	31	

The two squadrons advanced in line ahead, the Danes coming up on the beam of the Austrians. The Niels Juel joined action with the Schwartzenburg, and the Jylland with the Radetzky, the Heimdal attempting to reach the gun-boats, which

steamed up on the unengaged side of the frigates, causing the latter to steam in a circle. The action was fought in this manner, steaming in a circle of which the gun-boats were the centre and the Danes 600 yards outside the Austrians, the Heimdall joining in the attack on the Radetzky. After three hours, the Schwartzenburg was set on fire and the Austrians ran for Helgoland, the Danes hauling off at the neutral-ground limit. Indecisive action.

Battle of Lissa, July 20, 1866.

AUSTRIAN FLEET.

IRON-CLAD FRIGATES.	WOODEN SQUADRON.
Ferdinand Max.	Five frigates.
Hapsburg.	One corvette.
Don Juan d'Austria.	Fourteen gun-boats.
Kaiser Max.	
Prinz Eugen.	
Salamander.	
Drache.	

ITALIAN IRON-CLAD FLEET

Re d'Italia.	Maria Pia.
Re di Portugal.	San Martino.
Principe di Carignano.	Affondatore.
Ancona.	Palestro.
Castelfidardo.	
Varese, Terribile, and Formidabile not in action.	
Wooden fleet did not come up.	

The Austrians advanced in three echeloned lines ahead, the Ferdinand Max (flag-ship) leading the right and advanced iron-clad line. The wooden frigates formed the centre line, and the gun-boats the left and rear. All in close order. The Italians on sighting the Austrian fleet formed in single line ahead, open order, covering a distance of over five miles. The head of the Italian line opened fire on coming within gunshot. The Austrians, turning together eight points to port, sent a broadside into the head of the Italian line and, resuming the former course, immediately pierced the Italian line astern of the third ship (between the Ancona and the Re d'Italia), half of his iron-clads passing through this interval and the other half between the Re d'Italia and the Palestro. The leading Italian division turned to starboard to attack the Austrian wooden fleet, and Tegethoff to foil this manœuvre turned and passed back through the same intervals. The rest of the Italian fleet closing up on the broken Austrian line, and the smoke concealing

signals, the action became a mêlée. The Ferdinand Max made two attempts to ram two different vessels, both being avoided by the helm. A third attempt on the Re d'Italia was successful, striking her under the counter and sinking her. At the time, the Re was engaged with three Austrians on his bow and beam. The Italians state that his steering-gear was shot away; the Austrians, that he was backing.

Three Austrians (two iron-clads and one wooden frigate) concentrated on the Palestro and set her on fire; she drew out of action and blew up in about an hour. The San Martino, fighting in company with the Re d'Italia, hauled out of action when the latter was sunk. The Affondatore (flag-ship) made two ineffectual attempts to ram, but her clumsy steering-gear and slow speed made the attempts abortive. The Re di Portogalo made a fine attempt to ram the Kaiser Max, which the latter avoided by turning *towards* the Portugalo and going full speed, the ships rubbing sides, bringing down the Kaiser's foremast, which fell on the smoke-stack and caught fire but was extinguished. The Portugalo then ran the gauntlet of the two iron-clad divisions, reaching her own line, and the Italian fleet hauled out of action, the Austrians not chasing. The Italian loss was two iron-clads; killed, 650; wounded, 40. Austrians, 136 killed and wounded, of whom three quarters belonged to the Kaiser Max. Partial success.

D A S H E S.

Passes of the Mississippi, October 12, 1861.

At 4 a.m. the Confederate ram Manassas steamed suddenly into the Federal squadron at anchor in the Passes below New Orleans—

	Guns.		Guns.
Richmond.....	25	Union.....	4
Water Witch.....	3		

SAILING CORVETTES.

Vincennes.....	10	Preble.....	11
----------------	----	-------------	----

striking the Richmond a glancing blow. Chains were slipped at once, and the Richmond avoided a second blow by sheering. The ram passed back up the river. On the Confederate side the dash was a failure. On the Federal side the Vincennes

was run ashore, deserted, and accident only saved the vessel, a train having been laid to her magazine and fired by Commander Handy. The train is said to have been put out by one of the crew before leaving, and the ship was hauled off after daylight.

Mississippi River, above Vicksburg, July 15, 1862.

At about 7 a.m. the Confederate ram Arkansas made a dash down the river through the Federal squadron lying at anchor.

	Guns		Guns.
Hartford.....	28	Wissahickon	4
Richmond.....	25	Winona	4
Oneida.....	10	Sciota.....	4
Iroquois.....	7		

As she passed through without attempting to ram, broadsides were exchanged. The Arkansas was disabled, but not caught. Federal loss: killed, 5; wounded, 16.

Charleston Blockading Fleet, February 2, 1863.

At about 4 a.m. a Confederate iron-clad ram made a dash from the harbor into the blockading squadron.

	Guns.		Guns.
Keystone State.....	13	Augusta.....	10
Housatonic.....	13	Mercedita.....	9
Quaker City.....	9	Memphis.....	7

Running at the Mercedita, she rammed her on the starboard beam, and at the same time put a shot through her boiler, completely disabling her. The ram then passed under her stern, demanded and received her surrender, but did not take possession, the crew being paroled. The Keystone State was then attacked, but avoided being rammed, although she received a shot through her boilers, completely disabling her. The ram then retired. Attack successful. Federal loss: killed, 24; wounded, 23; one crew paroled, two vessels disabled. Duration of attack, one hour.

IRON-CLADS AGAINST WOODEN VESSELS.

Hampton Roads, March 8, 1862.

On the morning of March 8th the Confederate ram Merrimac entered Hampton Roads, where were lying at anchor the

STEAM FRIGATES.

	Guns.		Guns.
Minnesota	50	Roanoke.....	50

SAILING FRIGATES.

Congress.....	50	St. Lawrence.....	12
Cumberland.....	24		

Running directly at the Cumberland, the ram struck her under the counter, sinking her in fifteen minutes. Turning to the Congress, which had slipped her cable and run ashore, the ram took a position under her stern at 50 yards distance, and forced her to surrender after a fight of an hour. Possession was not taken of her, and the ship was fired and deserted, blowing up in a few hours. The Minnesota having grounded where the Merrimac could not get at her, these two engaged at long range, the Roanoke and St. Lawrence taking part for about four hours, when the Merrimac drew out of action leaking badly from the effects of ramming the Cumberland. Federal loss: 2 sailing frigates; killed, 247; wounded, 90.

Roanoke River, April 18, 1864.

At 11 p.m. of the 18th the Confederate ram Albemarle was discovered coming down the Roanoke River. In obedience to previous instructions from the Admiral, the two gun-boats present (Miami, 12 guns, and Southfield, 4 guns) were lashed alongside each other to receive the attack, the intention being to put the ram between the two vessels, and while held by lashings fight her at point-blank on both sides. After lashing, the gun-boats were headed for the Albemarle, going full speed. The arrangement was perfect for a *test* of the plan. The ram-scraping the port side of the Miami with her

proW, struck the starboard bow of the Southfield, staving her in forward; the forward lashings were broken, and the gun-boats swung out of the angle of fire after giving but one broadside. The ram backed clear to get room for a blow at the Miami, but the latter, having swung head down stream, escaped. The Southfield sank in about fifteen minutes. Federal loss: killed, 1; wounded, 11; missing, 67; 1 gun-boat sunk.

Albemarle Sound, May 5, 1864.

The squadron blockading Albemarle Sound had received orders that in case the ram Albemarle appeared, the vessels were to form in double line ahead.

	Guns.		Guns.
Miami.....	12	Mattabeset.....	6
Ceres.....	4	Sassacus.....	6
Commodore Hull.....	6	Wyalusing.....	4
Seymour.....	4	Whitehead.....	4

At 4.45 p.m. the Albemarle was sighted coming into the sound accompanied by two small gun-boats. The squadron formed and steamed to meet her, the Mattabeset and Sassacus delivering a broadside in passing at 100 yards. The ram attempted to run the Sassacus down, but the latter avoided her, being thrown out of the line in the manoeuvre. Being in the vicinity of one of the Confederate gun-boats, the Sassacus gave her a broadside, received her surrender, and sent her out of action to an anchorage. Turning to resume her place in line, the Sassacus found herself in position to ram the Albemarle, and went at her full speed, striking her fairly amidships, and heeling her over considerably. The two vessels were in close contact for about ten minutes, when the Sassacus swung alongside and received a shot through her boilers, partially disabling her. The ram getting clear drew out of action and steamed up the river, chased for some distance by the squadron. Casualties on the Federal side: killed, 4; wounded, 25; 1 gun-boat disabled. Confederates: 1 gun-boat captured; 1 gun on the ram disabled. The bow of the Sassacus was somewhat broken and twisted, but not sufficient to leak.

Black Sea, July 23, 1877.

On the morning of the 23d the Russian gun-boat Vesta (6 guns), cruising in the sea, made out black smoke on the horizon at early daylight, and steamed towards it. When within less

than two miles she discovered it to be the Turkish iron-clad frigate *Assav-i-Tefvik* (14 guns), and turned to escape; a running fight ensued, lasting for two hours, the Turk slowly overhauling the *Vesta*. When within about half a mile, a shell from the *Vesta* exploded in the barbette turret of the Turk, disabling its gun, killing and wounding most of the crew. The latter then hauled off and the *Vesta* escaped. Action indecisive. Killed and wounded about equal on both sides.

Off Ylo, Peru, May 29, 1877.

The Peruvian iron-clad *Huascar*, having been taken possession of by a party of insurgents, and having committed depredations against British commercial vessels, was attacked off Iquique by the British frigate *Shah* and the corvette *Amethyst*. The *Huascar* running into shoal water prevented the close approach of the enemy, and the action was continued for about three hours, during which time neither of the British vessels was struck and no notable damage had been done to the *Huascar*. Just before dark the *Huascar* cleared the shoals and ran down the coast followed by the British until dark. One Whitehead torpedo was sent at her, but ineffectually.

After dark a launch was sent into the bay of Ylo with Whitehead torpedoes for the purpose of sinking the vessel, but she had escaped. Action indecisive. Casualties: Peruvian, killed, 1; wounded, 1. British, none. Neither vessel injured sufficiently to affect her fighting power. The *Huascar* was manned by a raw crew, causing her fire to be entirely ineffective.

Iquique Harbor, May 21, 1879.

The Peruvian iron-clads *Independencia* and *Huascar* appeared off Iquique Harbor on the morning of May 21st, finding there the Chilean gun-boats *Esmeralda* and *Covadonga*. The latter on discovering the enemy ran into shoal water, the iron-clads taking a position about 2000 yards away. After a short action, the *Covadonga* (apparently with the intention of dividing the fire and possibly escaping) attempted to run down the coast, the *Independencia* giving chase. The *Huascar* continued to engage the *Esmeralda*, and notwithstanding the short range, failed to hit her. At length a shore battery drove the *Esmeralda* into deep water, and before she could commence to manœuvre a shot from the *Huascar* disabled her engines. The *Huascar* then rammed her three times, the first two blows

being total failures on account of stopping the ship too quick. The third was a success, sinking the *Esmeralda* with her colors flying. The *Covadonga*, keeping in shoal water as much as possible, ran for two hours, the *Independencia* making three attempts to ram her and failing. At the fourth attempt the ship was missed, and the *Independencia* struck a rock and hung fast. The *Covadonga* at once turned, and taking a position under the Peruvian's stern, opened fire on him and forced him to surrender. The *Huascar* appearing at this time, possession could not be taken, and the *Covadonga* escaped. Attempts to haul the Peruvian off the rocks proving unavailing, she was fired and burned. In this action the Chilians lost the greatest number of men owing to the sinking of the *Esmeralda*, but the loss of the *Independencia* more than counterbalanced it.

D U E L S .

Monitor and Merrimac, March 9, 1862.

On the morning of the 9th the *Merrimac* steamed into Hampton Roads to finish the destruction of the wooden squadron which she had attacked the day previous (see page 166). The *Monitor* having arrived during the night steamed out to meet her after she had approached within gunshot of the *Minnesota*. After a short engagement at a distance of 200 yards, the *Merrimac* attempted to ram or force a surrender of the *Minnesota*, in doing which she ran ashore, and was for a short time exposed to the full broadside fire of the frigate. Getting clear, she again turned to the *Monitor*, and attempted to ram her, striking a slight ineffectual blow. The *Merrimac* kept on down the channel, the *Monitor* chasing for some distance, but hauling out of action when she found her speed and artillery power not sufficient to bring the *Merrimac* to terms. Casualties on the *Monitor*, 1 wounded, 2 temporarily disabled by the shock of the projectiles striking the turret against which they happened to be leaning. Action indecisive.

Alabama and Hatteras, January 11, 1863.

The *Hatteras* (6 guns) proceeding to blockade duty off Galveston went in chase of a sail on the morning of the 11th, and

running close to her, stopped and hailed. The answer returned was "Her Majesty's Steamer Vixen." The Hatteras then lowered a boat and sent it alongside. Before the boat was fairly started the hail came, "We are the Confederate steamer Alabama," accompanied by a broadside. The fire was returned at once, and the Hatteras attempted to close and board, but could not. In about five minutes she had been set on fire by one shell and her boiler was pierced by another. The Alabama then took a position under her stern, and in a few minutes forced her to surrender, the crew being transferred to the Alabama, and the Hatteras left to burn and blow up. Casualties: on the Hatteras, killed, 2; wounded, 5. Action decisive. (For fighting power of ships, see page 171.)

Weehawken and Atlanta, June 17, 1863.

At early daylight the Confederate ram Atlanta was seen coming down the Wilmington River, and the Federal monitors Weehawken and Nahant steamed in to meet her. The Atlanta opened fire at 1500 yards, and a few moments afterwards grounded. The Weehawken approaching within 300 yards opened fire, and forced the surrender of the ram in fifteen minutes. Five shots were fired by the Weehawken, all striking and three penetrating the ram, killing and wounding many people at the guns. The ram was taken possession of and sent in as a prize. Action decisive.

Kearsarge and Alabama, June 19, 1864.

The Alabama steamed out of Cherbourg Harbor on the morning of the 19th to meet the Kearsarge in accordance with a challenge sent out two days before. The Kearsarge, steaming out clear of neutral water, turned when at a good distance and headed for the Alabama. The action commenced at 1200 yards, the Alabama sending the first broadside, which was immediately returned by the Kearsarge. The action continued for 65 minutes at a distance of 900 yards, the two ships steaming in a circle. At the end of this time the Alabama surrendered, and in about twenty minutes after sunk. Action decisive.

Fighting Powers of the Hatteras, Alabama, and Kearsarge.

HATTERAS.	ALABAMA.	KEARSARGE.
Battery.	Battery.	Battery.
I 20-pdr. rifle.	I 100-pdr. rifle.	I 30-pdr. rifle.
I 30-pdr. "	I 68-pdr. "	II 11-inch smooth-bores.
IV 32-pdr. smooth-bores.	IV 32-pdr. smooth-bores.	IV 32-pdr. "
Battery Fought.	Battery Fought.	Battery Fought.
II rifles, II 32-pdrs.	II rifles, III smooth-bores.	I rifle, II 11-inch, II 32-pdrs.
Crew, 125 men.	Crew, about 170 men.	Crew, 163 men.

Meteor and Bouvet, November 9, 1870.

On the morning of November 8th the French gun-boat Bouvet (5 guns) steamed out of Havana and beyond the neutral limit to wait for the Prussian gun-boat Meteor (3 guns) to come out in answer to a challenge. The Meteor, after waiting in port twenty-four hours as prescribed by law for the sailing of belligerent vessels, steamed out, and the action commenced about two miles outside of the neutral limit, the Bouvet firing the first gun. After a few manœuvres the Bouvet closed with the intention of ramming, and was partially avoided, striking a glancing blow abeam and slipping along, carrying away the Prussian's main and mizzen masts, the rigging fouling the Meteor's screw. In return, the Meteor put a shot through the Bouvet's steam-chest, partially disabling her. The latter made sail at once and escaped into neutral water, the Meteor keeping up a fire but unable for a time to chase owing to the fouled screw. Action indecisive on account of the proximity of neutral water. Casualties : Bouvet, 3 wounded. Meteor, 3 killed ; 1 wounded. Duration of action, less than one hour.

RÉSUMÉ.

Number of duels noted, 5. Decisive, 3. Indecisive, 2. Of the indecisive fights, one was due to lack of speed for overhauling the opponent and continuing the action ; the other to the temporary disability of fouling the screw and the proximity of neutral water. In the decisive actions, two were decided by sinking, although in both cases the ship surrendered first.

Action off Point Tetas, October 8, 1879.

At daylight on the 8th the Chilian iron-clad corvette Blanco Encalada sighted the Peruvian iron-clad turret-ship Huascar, and gave chase. The Huascar, running to the northward, and slowly distancing the Blanco, was headed by the Chilian iron-clad corvette Almirante Cochrane. These two ships then engaged, and in about half an hour the Blanco closed and opened on the Huascar, placing her between two fires. After an action of one hour and a half the Huascar surrendered, having been much cut up, and having lost her three senior officers. Casualties: Blanco Encalada, none. Almirante Cochrane, 2 killed, 10 wounded.

NOTE.—After careful research it has been found that in every case cited in which boilers were penetrated by projectiles, the part of the boiler hit was *above the water-line*.

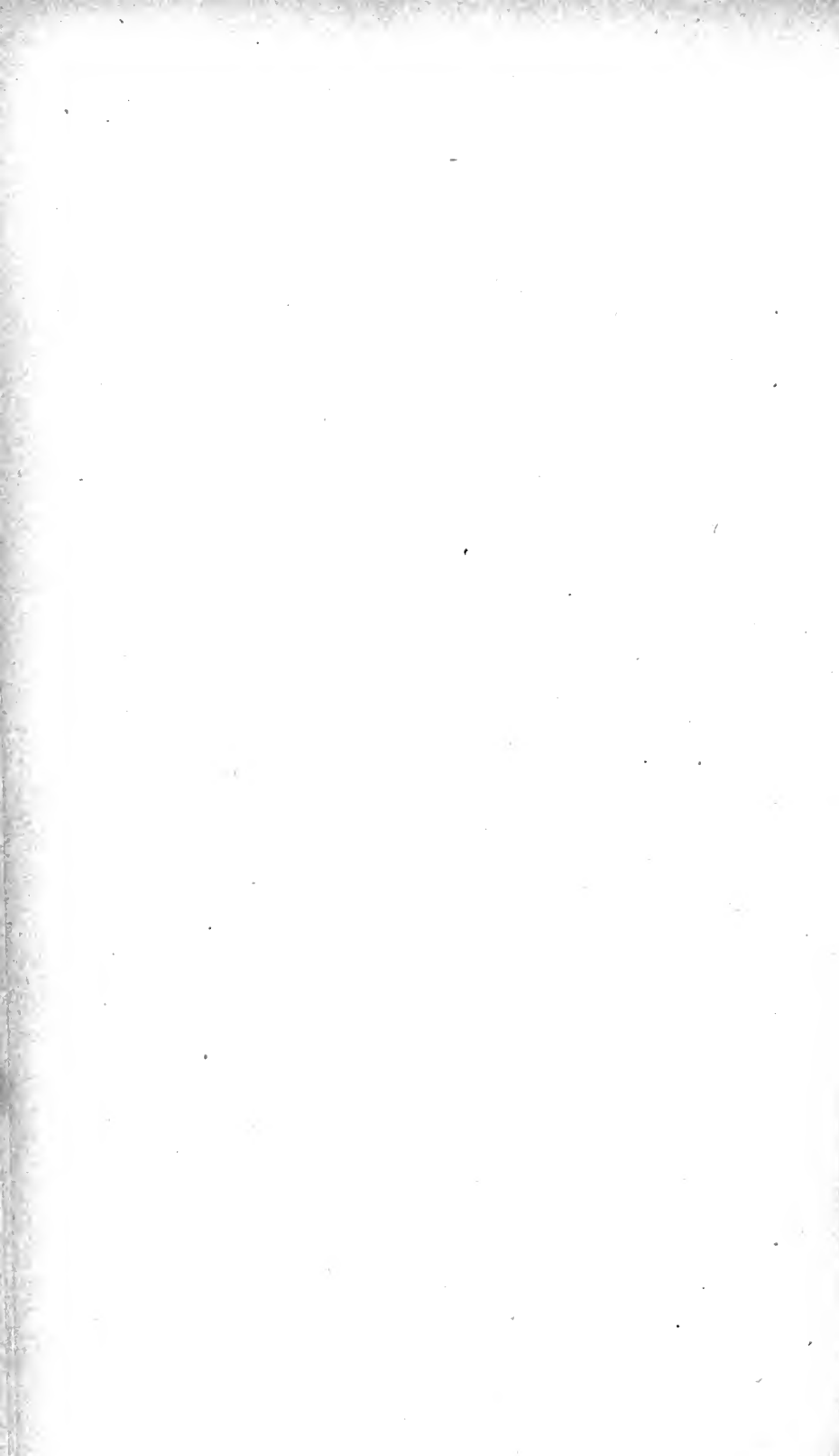

PART II.



NAVAL ORDNANCE.

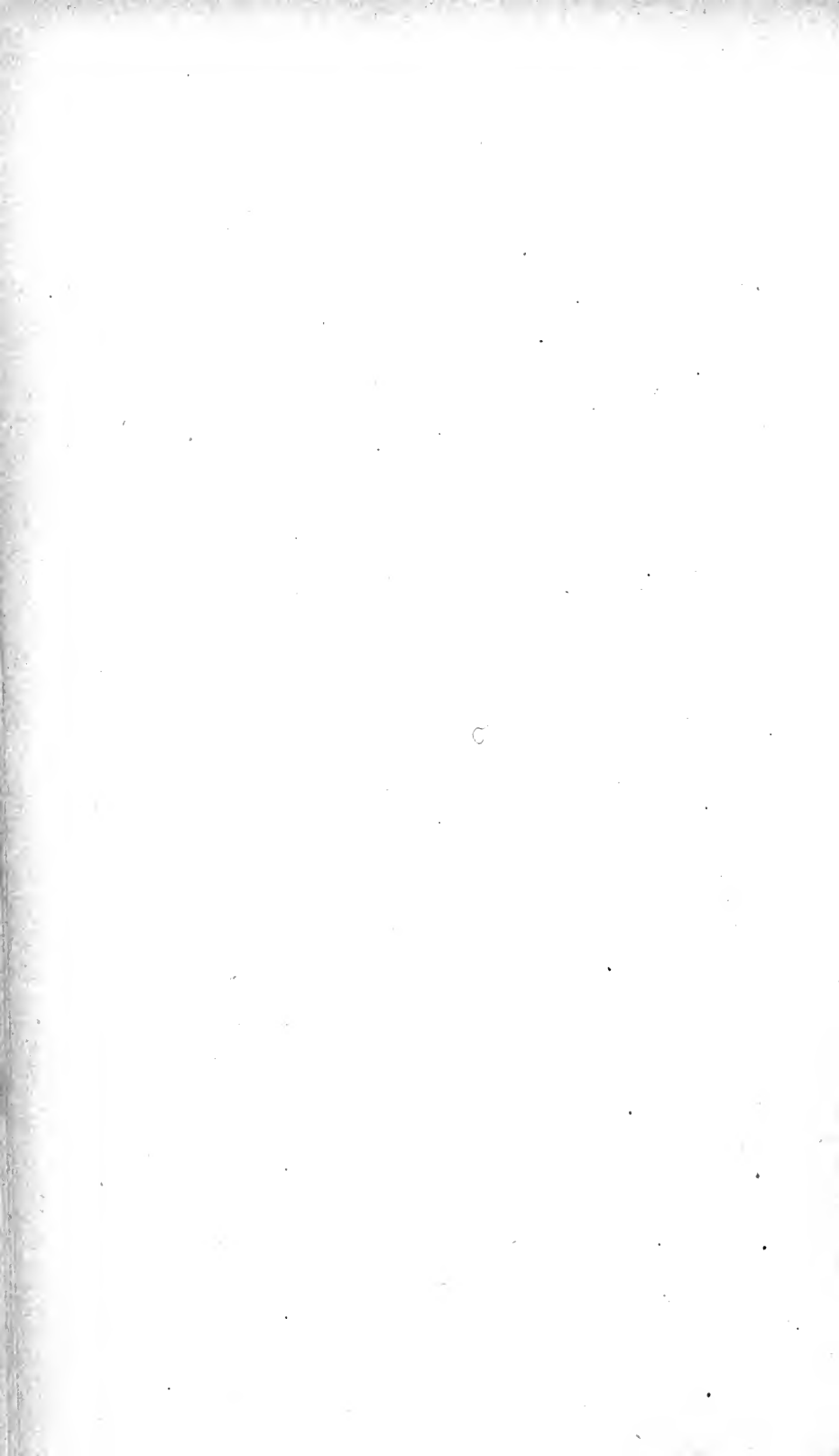

NAVAL ORDNANCE.

AUSTRIA.

NAME, NATURE, AND CLASSIFICATION.	Calibre.	LENGTH.			Number of Grooves.	Twist of Rifling.	WEIGHT.		Preponderance.	
		Over all.	Rifled Bore.	Powder Chamber.			Gun, including Breech-block.	Breech-block.		
										In.
Krupp Pattern Steel Breech-loaders.	28 cm.	11	240	170.7	36.41	64	45	60,500	2,266
	26 "	10.24	225	148.4	46.06	32	70	48,400	1,947
	24 "	9.27	206	136	41.7	32	70	34,100	1,408
	24 "	9.27	185	115.3	41.7	32	64.7	32,450	1,419
	21 "	8.24	165	105	37	30	59	19,400	1,078
Wahrendorff Breech- loaders.	15 "	5.87	152	112.4	22.6	36	45	8,800	321	248
Armstrong Muzzle- loaders.	23 "	9	156	104	20.9	6	45	27,900	255
	18 "	7	130	85.5	18.7	3	35	14,500	394
Cast-iron Breech- loaders.	15 "	5.87	121	89.8	16.9	30	63	6,300	178	299
	12 "	4.74	109	84.4	12.4	24	52	3,300	106	273
Bronze Breech- loaders.	9 "	3.43	81	57.5	16.5	24	45	1,070	55	103
	7 "	2.6	39	23.8	11	18	30	196	49	48.4

AUSTRIAN ORDNANCE—(CONTINUED.)

NAME, NATURE, AND CLASSIFICATION.	CARRIAGES.			PROJECTILES.						POWDER CHARGE.		
	Carriage.	Slide.	Height of Axis of Bore above Deck.	Full Weight.			Bursting Charge.			For Steel and Chilled Shot.	For Common Shell.	
				Steel.	Chilled.	Common.	Steel.	Chilled.	Common.			
	Lbs.	Lbs.	In.	Lbs.	Lbs.	Lbs.	Lbs.	Lbs.	Lbs.	Lbs.	Lbs.	
Krupp Pattern Steel Breech- loaders.	28 cm.....	29,260	29,260	53	559	574	473	14.3	7.7	25.3	121	121
	26 ".....	6,140	12,617	46	395	354	8.8	20.2	70.4	59.4
	24 ".....	4,900	9,845	46	292	263	6.6	3.7	14.9	52.8	44
	24 ".....	5,814	7,528	45	292	308	263	6.6	3.7	14.9	52.8	44
	21 ".....	6,194	10,412	45	206	196	172	4.4	3.1	14.9	37.4	30.8
Wahrendorff Breech- loader.	15 ".....	1,878	3,740	39	84.7	69	2.1	5.1	17.6	14.3
Armstrong Muzzle- loaders.	23 ".....	4,188	6,917	44	249	257	5.9	18.5	50.6	30.8
	18 ".....	2,956	3,757	45	114	118	1.1	7.9	38.6	13.2
Cast-iron Breech- loaders.	15 ".....	1,047	1,207	39	61	1.9	4.7
	12 ".....	715	32	32	1.1	2.4
Bronze Breech- loaders.	9 ".....	536	38	1449
	7 ".....	294	21	6.41635

AUSTRIAN ORDNANCE—(CONTINUED.)

NAME, NATURE, AND CLASSIFICATION.	POWDER CHARGE.		INITIAL VELOCITY.			WORKING EFFECT.			Penetrating Power.	
	Ordinary.	Saluting.	Steel.	Chilled.	Common.	Steel.	Chilled.	Common.		
	Lbs.	Lbs.	Ft.	Ft.	Ft.	Foot Tons.	Foot Tons.	Foot Tons.		
Krupp Pattern Steel Breech-loaders.	28 cm.....	1,542	1,673	9,473	14.8
	26 ".....	59.4	19.8	1,404	1,378	5,404	4,666	11.6
	24 ".....	44	15.4	1,420	1,378	4,087	3,464	10.6
	24 ".....	44	15.4	1,378	1,345	1,329	3,838	3,223	3,867	10.25
	21 ".....	30.8	8.8	1,394	1,253	1,345	2,781	2,198	2,153	9.3
Wahrendorff Breech-loaders.	15 ".....	14.3	4.7	1,608	1,509	1,379	1,060	7.8
Armstrong Muzzle-loaders.	23 ".....	30.8	15.4	1,411	1,000	3,429	1,788	9.9
	18 ".....	13.2	8.8	1,493	1,066	1,766	928	8.1
Cast-iron Breech-loaders.	15 ".....	4.7	4.7	1,017	438
	12 ".....	2.4	2.4	1,000	222
Bronze Breech-loaders.	9 ".....	.9	.9	1,469	309
	7 ".....	.35	.35	977	42

AUSTRIAN ORDNANCE—(CONTINUED.)

The first type of rifled ordnance regularly introduced into the Austrian naval service was the old-type Armstrong muzzle-loader. In addition there are still found a few guns of present obsolete types which never passed the experimental stage. Within the past five years (1876) the Krupp breech-loader has been adopted as the standard pattern, and all guns of a higher calibre than 15-cm. are now of this type, although many complete Armstrong batteries are now found on board ship in the wooden fleet. The boat-guns are of the Krupp type breech-loaders, but are all manufactured of bronze, or what is generally known as Uchatius metal from its method of manufacture.

The Uchatius Construction.

The peculiarity of the Uchatius construction is the method of manipulating the bronze of which the gun is made, by which the metal is given all the advantageous qualities of steel. The body of the gun is cast in a chill mould, by which the cooling is so rapid that the mechanical mixture of tin and copper has no opportunity of separating and forming tin spots as is the case with ordinary bronze castings. After boring the gun, a succession of steel mandrels is driven through the bore, putting the whole casing in a condition of extreme tension on the exterior and compression on the interior, so that the different strata of metal are in proper condition for resisting tangential strains.

ARGENTINE ORDNANCE.

In the Argentine navy the heavy calibres (used on gun-boats of the Andes class) are Armstrong muzzle-loaders of the modified pattern (see page 195), the medium calibres are divided between old-type Armstrong muzzle-loaders and Krupp breech-loaders. The machine-guns used are Gatlings (see page 308). There is no regular gun factory in the country, the armament being entirely purchased abroad.

BRAZILIAN ORDNANCE.

The standard ordnance adopted in the Brazilian navy is the Whitworth (see page 218), both muzzle and breech loaders. Machine-guns are of the Gatling type (see page 308).

CHILIAN ORDNANCE.

There is no standard ordnance in the Chilian navy, although the iron-clads are provided with Krupp guns, whilst the wooden fleet is armed with Armstrong muzzle-loaders. It is probable that the Krupp breech-loader will gradually supersede other types. The machine-guns are of the Gatling type.

CHINESE ORDNANCE.

The greater part of the rifled ordnance used in China is of the Armstrong muzzle-loading pattern. Some of their wooden vessels carry batteries of Krupp guns, and others Vavasseurs (see page 219). The Gatling machine-gun has been introduced into this service.

DANISH ORDNANCE.

There are three separate patterns of rifled ordnance found in the Danish navy. The favorite appears to be the Krupp breech-loader, whilst there are many guns of the Finspong pattern (see page 276, "Swedish Ordnance"). The Armstrong muzzle-loader has apparently the numerical superiority.

ENGLISH ORDNANCE.

NAME, NATURE, AND CLASSIFICATION.	LENGTH.			Number of Grooves.	Twist of Rifling.	Weight of Guns.	Preponderance.			
	Over all.	Rifled Bore.	Powder Chamber.							
	In.	In.	In.							
17-inch, 100-ton	392	308	55	27	$\frac{1}{4}^{\circ}$	229,000	8,960			
Muzzle-loading, built-up Guns. Woolwich pattern.	Armor-piercing.	16-inch, 80-ton	321	231.5	56.5	179,200		
		12.5-in., 38-ton.....	230	170.5	27.5	9	$\frac{3}{32}^{\circ}$	85,120	
		12-inch, 35-ton.....	195	135	27.5	9	$\frac{3}{32}^{\circ}$	78,400	120	
		12-inch, 25-ton	182.5	127	18	9	$\frac{1}{16}^{\circ}$	56,000	616	
		11-inch, 25-ton	180	119	26	9	$\frac{3}{32}^{\circ}$	56,000	168	
		10-inch, 18-ton.....	180	119	26.5	7	$\frac{1}{16}^{\circ}$	40,300	952	
		9-inch, 12-ton.....	156	104	21	6	$\frac{3}{16}^{\circ}$	26,900	560	
		8-inch, 9-ton.....	144	99.5	18.5	4	$\frac{3}{16}^{\circ}$	20,100	448	
		7-inch, 90-cwt.....	131	95.5	15.5	3	35	10,100	560	
		7-inch, 6½-ton.....	133	95.5	15.5	3	35	14,500	336	
		64-pdr., 64-cwt., shell.....	118	90	7.5	3	40	7,160	336	
		Boat.	9-pdr., 8-cwt.....	72	59.8	3.7	3	30	896	7
			9-pdr., 6-cwt.....	61	49.3	3.7	3	30	672	29.5
			7 pdr., 200-lb., steel.....	41	34	2	3	20	200	5
64-pdr., 71-cwt., convert'd	122.7	96.27	7	3	40	7,950	714			
Breech-loaders. Armstrong pattern.	Shell.	7-inch, 82 cwt.....	126	83.5	16	76	37	9,184	776	
		40-pdr., 32-cwt.....	126	92.87	13.5	56	36.5	3,584	607	
		40-pdr., 35-cwt.....	127	92.87	13.5	56	36.5	3,920	532	
		20-pdr., 15-cwt.....	72	43.12	11	44	38	1,680	168	
	Boat.	20-pdr., 13-cwt.....	72	43.12	11	44	38	1,456	164	
		9-pdr., 6-cwt.....	68	45.5	7	38	38	672	82	
		6-pdr., 3-cwt.....	66	46	7	32	30	336	55	
		12-pdr., 8-cwt.....	78	52.87	8.5	38	38	896	199	

ENGLISH ORDNANCE—(CONTINUED.)

NAME, NATURE, AND CLASSIFICATION.		CARRIAGES.			PROJECTILES.							
		Weight.		Height of Axis of Bore above Deck	Entire Weight.			Weight.				
		Carriages.	Slide.		Chilled.	Common.	Shrapnel.	Burster for Chilled.	Burster for Common.			
		Lbs.	Lbs.	In.	Lbs.	Lbs.	Lbs.	Lbs.	Lbs.			
17-inch, 100-ton.....		Turret	2,000	11.25			
Muzzle-loading, built-up Guns. Woolwich pattern.	Armor-piercing.	16-inch, 80-ton.....		Turret	1,700	9.9	
		12.5 in., 38-ton.....		Turret	800	843	14	43	
		12-inch, 35-ton.....		25,000	Turret	45	700	615	612	6.5	40	
		12-inch, 25-ton.....		{ 11,800	Turret	60	600	497	497	6.9	37.7	
				{ 23,100	Turret							
		11-inch, 25-ton.....		{ 21,120	Turret	49	535	536	5.5	29.7	
				{ 10,700	Turret							
		10-inch, 18-ton.....		{ 21,000	Turret	49	400	398	404	4.5	20.25	
				{ 8,940	Turret							
		9-inch, 12-ton.....		4,800	7,400	44	250	250	255	2.5	19	
		8-inch, 9-ton.....		4,780	6,710	44	180	182	180	2.5	14.5	
		7-inch, 90-cwt.....		2,700	3,900	41	115	117	116	8.75	
		7-inch, 6½-ton.....		3,500	4,700	41	115	117	116	8.75	
		64-pdr., 64-cwt., shell..		1,430	2,600	41.5	64	66	7.2	
		Boat.		9-pdr., 8-cwt.....		532	356	41.5	9	9.75
9-pdr., 6-cwt.....				532	336	9	9.755	
7-pdr., 200-lb., steel...				112	252	7	7.54	
64-pdr., 71-cwt., con- verted.....				1,600	2,700	64	{ 66 Segment shell. }	7.2	
Breach-loaders. Armstrong pattern.	Shell.	7-inch, 82-cwt.....		1,760	2,796	42.5	90	102	7.6	
		40-pdr., 32-cwt.....		1,595	1,425	42	38	4025	
		40-pdr., 35-cwt.....		1,595	1,425	42	38	4025	
		20-pdr., 15-cwt.....		616	977	29	20.5	20	1.2	
	Boat.		20-pdr., 13-cwt.....		616	977	29	20.5	20	1.2
			9-pdr., 6-cwt.....		298	504	9.5	8.54
			6-pdr., 3-cwt.....		560	6	5.5
			12-pdr., 8-cwt.....		364	336	11.25	115

ENGLISH ORDNANCE—(CONTINUED.)

NAME, NATURE, AND CLASSIFICATION.	POWDER CHARGE.				INITIAL VELOCITY.			
	For Steel and Chilled Shot.	For Common Shell.	Ordinary Firing.	Saluting.	Chilled Shot.	Common Shell.		
	Lbs.	Lbs.	Lbs.	Lbs.	Ft.	Ft.		
17-inch, 100-ton	440	1,590		
Muzzle-loading, built-up Guns. Woolwich pattern.	Armor-piercing.	16-inch, 80-ton.....	370	1,520	
		12.5-in., 83-ton.....	130	1,451	
		12-inch, 35-ton	110	85	1,300
		12-inch, 25-ton	85	67	55	1,180
		11-inch, 25-ton	85	70	60	1,315
		10-inch, 18-ton	70	60	44	1,361
		9-inch, 12-ton	50	43	30	15	1,420
		8-inch, 9-ton	35	30	20	12	1,413
		7-inch, 90-cwt.....	30	22	14	10	1,525
		7-inch, 6½-ton	30	22	14	10	1,250
Boat.	64-pdr., 64-cwt	10	10	6	1,383	
	9-pdr., 8-cwt	1.75	1.75	1.5	1,380	
	9-pdr., 6-cwt.....	1.5	1.5	1	1,390	
	7-pdr., 200-lb., steel.....75	.75	.25	968	
	64-pdr., 71-cwt., converted...	8	8	6	1,230	
Breech-loaders, Armstrong pattern.	Shell.	7-inch, 82 cwt.....	11	11	7	1,165
		40-pdr., 32-cwt.....	5	5	3	1,180
		40-pdr., 35-cwt.....	5	5	3	1,180
		20-pdr., 15-cwt.....	2.5	2.5	1.5	1,000
	Boat.	20-pdr., 13-cwt.....	2.5	2.5	1.5	1,000
		9-pdr., 6-cwt.....	1.1	1.1	1	1,035
		6-pdr., 3-cwt.....75	.75	.7	1,046
		12-pdr., 8-cwt.....	1.5	1.5	1	1,239

ENGLISH ORDNANCE—(CONTINUED.)

NAME, NATURE, AND CLASSIFICATION.	MUZZLE ENERGY.		PENETRATION. (IRON.)		REMARKS.			
	Chilled Shot.	Common Shell.	At 500 Yards.	At 1000 Yards.				
	Foot Tons.	Foot Tons.	In.	In.				
17-inch, 100-ton	37,700				
Muzzle-loading, built-up Guns. Woolwich pattern.	Armor piercing.	16-inch, 80-ton	27,213	27.5	26.4	} Woolwich groove. Increasing twist.	
		12.5-in., 38-ton	11,676	18.7	17.7		
		12-inch, 35-ton	8,200	15.4	14.6		
		12-inch, 25-ton	7,030	13.9	13.1		
		11-inch, 25-ton	6,415	13.8	13.1		
		10-inch, 18-ton	5,160	12.7	12		
		9-inch, 12-ton	3,496	10.4	9.6		
		8-inch, 9-ton	2,492	9.8	9.5		
		7-inch, 90-cwt	1,855	8.8	8.6		
		7-inch, 6¼-ton	1,246	7.7	7.1		} Woolwich groove. Uniform twist.
64-pdr., 64-cwt., shell..	848	} Shunt groove. Uniform twist.			
Breach-loaders, Armstrong pattern.	Boat.	9-pdr., 8-cwt	528	} Modern French groove. Uniform twist.	
		9-pdr., 6-cwt	120		
		7-pdr., 200-lb., steel..	45.5		} French groove. Uniform twist.
		64-pdr., 71-cwt., conv'rt'd	670		} Plain groove. Uniform twist.
Breach-loaders, Armstrong pattern.	Steel.	7-inch, 82-cwt	847	} Armstrong multigroove. Uniform twist.	
		40-pdr., 32-cwt	378		
		40-pdr., 35-cwt	378		
	Boat.	20-pdr., 15-cwt	142		
		20-pdr., 13-cwt	142		
		9-pdr., 6-cwt	64		
		6-pdr., 3-cwt	45.6		
12-pdr., 8-cwt	117				

ENGLISH ORDNANCE—(CONTINUED.)

GUNS.

The old cast and wrought iron smooth-bore guns are now obsolete, and only found in service at dock-yards for saluting and experiment, and forming the broadside batteries of some of the training ships.

The rifled ordnance consists of the Woolwich muzzle-loader, the Palliser converted muzzle-loader, the Armstrong breech-loader, and the Gatling machine-gun.

The Woolwich type is subdivided into marks or patterns of each calibre corresponding to the gradual improvements in

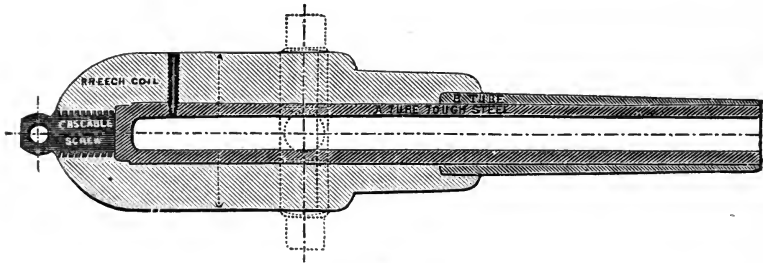

7-inch Mark III.

manufacture. Mark I. is in most cases the original Armstrong pattern, in which the jacket is composed of a large number of

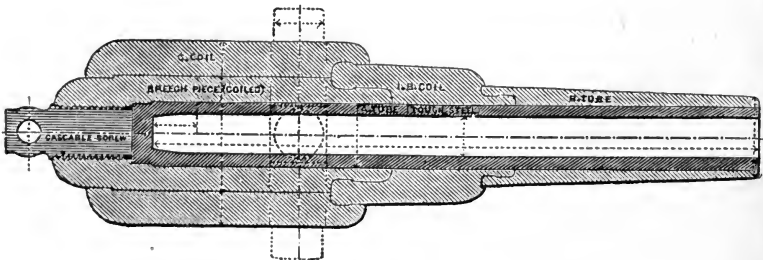

10-inch Mark I.

small coils or bands. In the other marks the number of the coils is decreased, whilst each one is increased in size.

The Palliser converted type is confined to the 64-pdr. calibre.

The Armstrong breech-loader is no longer manufactured,

but there are many guns of this type in service. These breech-loaders were originally of two types, known as the screw and

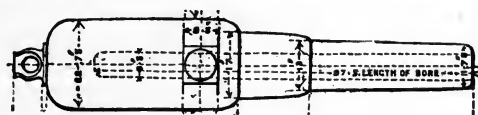

64-pdr.

the wedge gun. The latter was designed especially for naval use, but it has been entirely withdrawn from service, leaving only the screw type. It is not improbable that another type of breech-loaders will eventually find its way into service, having a breech-closing arrangement similar to the French type in principle.

Various systems of grooves will be found in these guns, corresponding to different stages of development. In the

SECTION OF GROOVE FULL SIZE:

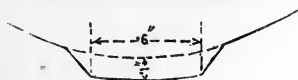

French Groove.

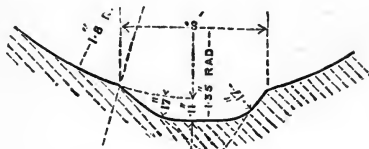

French Modified Groove.

7-pdr. the French groove is used, having sharp angles, the loading side being at a sharper pitch than the driving. In the 9-pdrs. appears the modified French groove, in which the angles are rounded off and the loading side is at right angles to the driving side. In the 64-pdr. converted gun the plain groove is used. This groove is almost rectangular, the driving



Woolwich Groove.

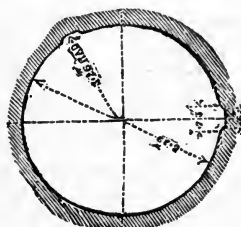

Plain Groove.

side being canted but little. In the 64-pdr. of 64 cwt. the shunt groove is used. This is a double groove, one half being deeper than the other, the rear end of the groove having a

shunt by which the studs are turned into the shallow half. The 7-inch muzzle-loaders have the Woolwich groove with a uniform twist. This groove is the final modification of the original French groove. The higher calibres up to the 16-inch gun have the Woolwich groove with an increasing twist. The 16-inch calibre will have the plain multigroove, or the groove ordinarily used for expanding projectiles. The breech-loaders have the Armstrong multigroove, a groove which in section is not unlike a saw-tooth.

7-pdr. Steel R. M. L. 200 lbs.

Introduced into service in 1873. Made of a single block of steel, having no swell at the muzzle, but a small dispart patch into which the fore sight screws. Copper vent bouch. The sight is a plain, centre hind sight set at a permanent angle of deflection of 3° . It seats in a hole bored in the metal of the gun, having a simple clamp-screw to hold it in position. Two sight-bars are used with the gun, one graduated to 6° and the other to 12° , the graduations on both being for intervals of $3'$. This gun may be distinguished from the 9-pdr. by the slope at the junction of the reinforce and chase, which is gradual.

9-pdr. Wrought Iron R. M. L. 6 and 8 cwt.

Introduced into service in 1871 and 1873. It consists of two parts—a toughened steel tube, and a jacket composed of two single coils and a trunnion-ring welded together. The cascabel is cut out of the solid end of the steel tube, and is re-

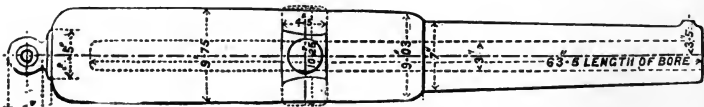

9-pdr.

cessed to receive the head of the elevating screw, which is fastened to it by a bolt and keep-pin. The 6 cwt. and 8 cwt. guns differ only in length and weight, the latter being $10\frac{1}{2}$ inches longer. The 7-pdr. and the 9-pdr. are of the same calibre, but the same projectiles cannot be used in both, as the twist is different and the studs on the 7-pdr. projectile are much wider than those of the 9-pdr. The arrangement of the sights is the same for both guns. It is easily distinguished by the abrupt step at the forward end of the jacket.

64-pdr. Wrought Iron R. M. L. 64 cwt.

There are three marks or patterns of this gun. Mark I. was adopted in 1864 to replace the Armstrong wedge breech-loaders. It belongs to the Armstrong type of construction, and consists of a wrought-iron coiled A tube, a forged breech-piece, a trunnion-ring, several outer coiled tubes, and a muzzle-ring. The A tube being bored all the way through, the joints at the bottom of the bore were closed by means of a heavy copper gas-check. The calibre is 6.3 inches, in order to permit firing 32-pdr. round shot from it. The greater part of these guns have been retubed with a steel A tube. In these, the plain groove is found, whilst the iron-tubed ones have the shunt groove. This gun is easily recognizable by its raised trunnion-ring, and also by the combination of the stepped breech with the muzzle-ring. Mark II. was adopted in 1866. It is made up of a coiled wrought-iron A tube, double at the chase, a forged breech-piece, a breech-coil composed of a double coil and trunnion-hoop welded together, a coil in front of the trunnions, and a cascabel block. The end of the bore of the A tube is reduced and forms a gomer chamber. These guns may be recognized either by the shunt rifling combined with the Woolwich form of gun or by the letter B marked on the left trunnion. Mark III. is made up of a solid-ended steel A tube, a breech-coil made up of a triple coil, trunnion-ring and coil in front of the trunnions welded together, and a forged cascabel block. These guns are similar in appearance to the 7-inch, but the sea-service guns of this mark have iron A tubes, and may be recognized by the shunt rifling.

64-pdr. R. M. L. 71 cwt. (Converted.)

Adopted in 1864. This gun is the old cast-iron 8-inch gun, which is bored out and tubed on the Palliser plan. The tube

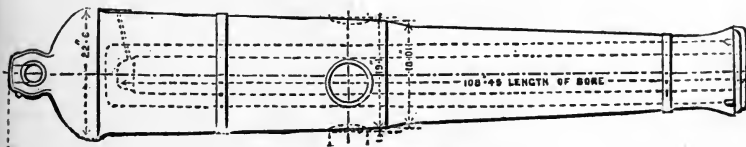

64-pdr. Converted.

is coiled and double at the rear, and, being through bored, the bottom joints are closed by a screw cup. After insertion the

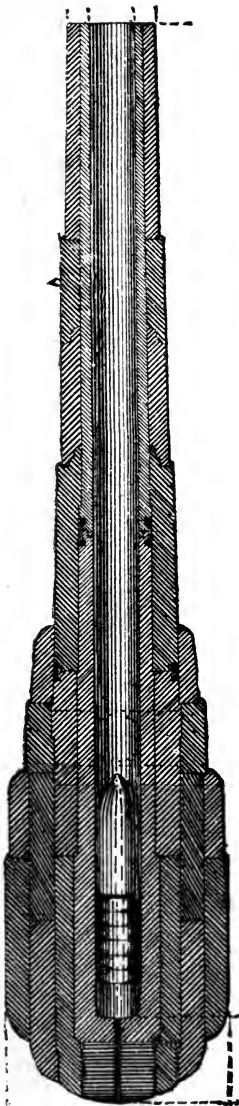

Armstrong 100-ton Gun (Improved Construction).

Armstrong Construction.

The first type of rifled guns introduced into the English naval service was the Armstrong, for both breech and



Armstrong Groove for Breech-Loader.

muzzle loaders. Fabrication of original breech-loader ceased in 1864, but many of this type still remain in service. The original construction of the muzzle-loader was modified in 1864, but the general type and principles were preserved and are still used. The present type of modified Armstrong construction is used by many foreign services, and the 100-ton gun has been introduced in the English service. The modified Armstrong breech-loading system for the 100-ton gun has been adopted in Italy.

The grooves of the breech-loader (original) are saw-toothed in shape, van-



Armstrong Shunt Groove for Muzzle-Loaders.

ishing at the shot-chamber for use with a lead-coated projectile.

The grooves of the muzzle-loader (original) are of the shunt or double-type, being cut to the full depth for the entire length and *one half the width* of the groove. The other half of the width is cut on an incline from the muzzle towards the chamber, this half being the driving side. The loading edge of the groove near the bottom is cut at a sharp angle so as to throw the studs of the projectile against the driving edges of the groove, and give it a close bearing. In coming out the studs ride up the incline of the

driving side and are pinched, centring the projectile. This groove is now obsolete. The groove of the improved muzzle and breech loaders is the plain groove.

BREECH-LOADING GUNS (ORIGINAL).

7-inch B. L. R. 82 cwt.

This calibre has been totally withdrawn from service, and has been replaced by the muzzle-loader. The body of the gun consists of an A tube, a breech-piece and B tube, a trunnion-ring and six coils. A vertical slot pierces the gun at the base of the chamber, into which fits a block called the vent-piece. This block is quite light and is easily lifted out or replaced by means of handles. The forward face of the block fits the rear of the chamber, and the escape of gas is prevented

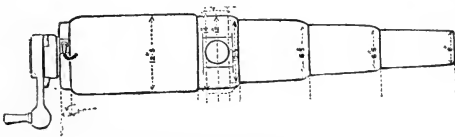

Armstrong Breech-Loader.

by means of a tin-cup gas-check. This vent-piece is held in position when in the gun by a block termed a breech-screw. This block is provided with a full screw-thread, and works longitudinally, the forward end of the block seating against the back of the vent-piece. This breech-screw is provided with a handle for turning, the handle being weighted at the end, and having a lost-motion movement by which the block may

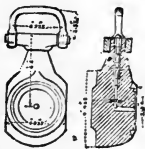

Vent-Piece.

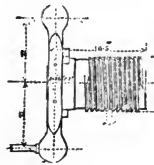

Breech-Screw.

be driven close home when screwed up. The vent is bored in the vent-piece, piercing it vertically to the centre, and then turning at right angles. The breech-screw is hollow, the hole being of slightly less diameter than the powder-chamber. When the vent-piece is out, the gun is cleaned and loaded through the breech-screw.

40-pdr. *B. L. R.* 32 and 35 cwt.

The same general type as the larger calibre. In this and smaller calibres there is no separate gas-check, the joint consisting of two bevelled copper facings, one on the vent-piece and the other in the powder-chamber, which form a close contact and seal the joint by expansion.

20-pdr. *B. L. R.*, 15 and 13 cwt.; 12-pdr. *B. L. R.*, 8 cwt.;
9-pdr. *B. L. R.*, 6 cwt.; 6-pdr. *B. L. R.*, 3 cwt.

Same construction as the 40-pdr., except that the coils are fewer.

Modified Breech-Loaders.

Although these guns are not yet introduced into service, they probably will be. The construction is the same in principle for the body of the gun as in the old breech-loaders, with slight modifications. The breech mechanism is almost identical with the French, the modifications being in the gas-check, which is of the general Broadwell type.

MUZZLE-LOADERS (ORIGINAL).

These guns consist of a steel solid-ended tube, reinforced by a number of coils connected by hook-joints. The coils are of wrought-iron bars, rolled into hollow cylinders and the turns

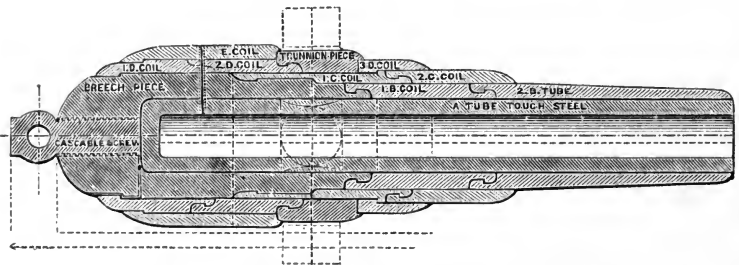

Armstrong 10-inch Muzzle-Loader (Original Construction).

welded in order to give a circumferential direction to the grain. Over the breech and powder-chamber a forged breech-piece fits, the grain of the iron running longitudinally. The base of the A tube is supported by a solid wrought-iron piece screwing into the forged breech-piece. A narrow spiral gutter is cut

around the A tube throughout its length, and carried out at the cascabel screw-thread. By means of this, in case that the steel tube gets cracked through, the leakage of gas gives warning by blowing out at the breech. Some of these guns (7-inch) have the shunt groove, and the later ones the Woolwich groove.

Modified.

The modified construction consists in abolishing the forged breech-piece, giving the steel tube a greater thickness over the powder-chamber, and decreasing the number of coils, whilst their thickness is increased individually. The guns are also given a greatly increased length of bore, and the powder-chamber is enlarged in diameter to permit the insertion of a heavier charge. Plain grooves.

At present the Elswick Company is engaged in supplying the Italian Government with breech-loading 100-ton guns. The breech-block is of the French type, and arrangements are made for moving the block as well as loading by hydraulic or steam power. The 100-ton gun has no carriage proper, its trunnions resting in heavy blocks on the fixed slide, being connected in rear with hydraulic recoil pistons which are themselves connected in such a manner as to equalize the strain of recoil. The movements of running out and in and loading are all performed by hydraulic power. The vent of the 100-ton gun is axial both in the breech and muzzle loader.

Armstrong Projectiles (see page 209). *Armstrong Fuze* (see page 211).

Armstrong Breech Mechanism and Rotating Belt.

The points of peculiarity of the Armstrong breech mechanism are: 1st. The face of the breech-block is made slightly

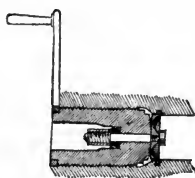

convex so that the gas-check springs back when the pressure comes on it, throwing the edge outwards, and making a wedged

joint. This comes free again the moment that the block is started. 2d. The rear of the shaft holding the gas-check in place is held by a spiral spring, so that in turning the block to lock it the gas-check is not revolved in its seat.

CARRIAGES.

Naval gun carriages and slides, as a rule, are built of plate-iron, although many of the wooden ones are still retained in service for the lighter calibres. The lighter carriages are worked by tackles, and the heavy ones by gearing. Breechings are no longer used with slide carriages, the recoil being checked by friction compressors or hydraulic recoil cylinders and buffers.

Wooden carriages are furnished for all smooth-bores and breech-loading rifles, and for 64-pdr. muzzle-loaders. Iron carriages may be furnished for these guns, but wooden ones are never furnished for others.

The wooden standing carriage is the old-fashioned four-truck one. The wooden rear-chock carriage is similar to what is known elsewhere as the Marsilly. Breechings are rove through holes in these carriages, and are not attached to the guns. The wooden slide-carriages and their slides are of the ordinary old-fashioned type. The compressor for these carriages consists on each bracket of the carriage of two iron plates with hinged pieces on their lower ends. They are suspended on iron bolts passing through the bracket so that their lower ends hang down and overlap the side of the slide. Through the upper ends of the plates and the bracket an iron screw and lever passes, whose motion separates or approaches the pieces, allowing them to release or grip the slide. Some slide-carriages are provided with hydraulic recoil cylinders.

Iron Field-Carriage.

This carriage consists of two $\frac{1}{4}$ -inch plate-iron brackets recessed to receive the axle-tree. These plates are strengthened by angle-irons riveted along the upper edge on the outer side from the trunnion-holes to the point. The brackets are lightened as much as possible by having pieces cut out of them. A front transom of plate-iron, having angle-irons riveted to it each side to connect it with the brackets; a similar transom about half way down the brackets; an iron trail-plate and axle-tree, and wooden wheels. The carriage makes a load for a mule, and the wheels another load. The elevating-gear consists of an iron stool-bed formed in front to hook loosely over

a cross-bar, while the rear end, provided with two small studs, rests in racks riveted to the brackets. This is for getting rapid elevations. For fine sighting a sliding quoin is fitted to the

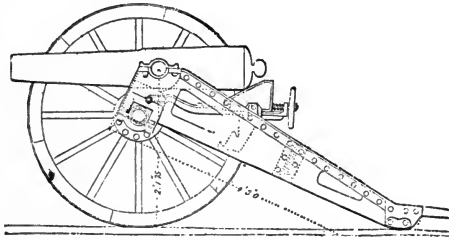

7-pdr. Field-Carriage.

stool-bed by clips, and is worked by a hand-wheel. Check-ropes are applied to the trail-eye and lashed to the wheels in firing. The Gatling gun is provided with a curved ratchet projecting down from the bottom of the gun-case, giving elevations by means of a hand-wheel and pinion.

Iron Boat-Carriage.

The boat-carriage is made up of two $\frac{5}{8}$ -inch plate brackets, having narrow stiffening pieces along the front and upper edges. The brackets are riveted to a bottom plate by angle-irons on the outer sides, and are connected in front by a transom of plate riveted to angle-irons, and in rear by another transom. It has two outside holding-down clips on each side.

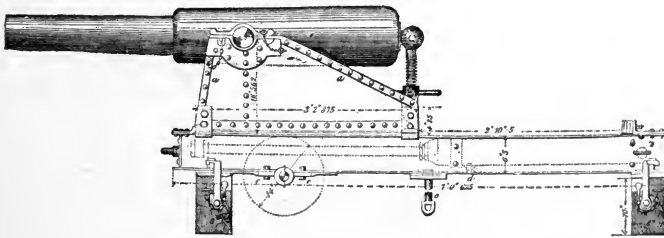

9-pdr. Boat-Carriage.

The elevating-screw admits of 10° elevation and 2° depression. The slide consists of two sides of girder-iron, $6\frac{1}{2}$ inches deep, and are joined by a connecting plate, three bottom plates, and a rear transom. These bottom plates have metal friction-plates attached beneath them. The centre as well as the front is fitted with a pivot-bolt. The transporting axle bolts beneath

the slide. The hydraulic buffer lies upon the centre and rear transoms, to each of which it is secured by a band. This buffer is nothing more than the ordinary type of long cylinder and piston.* The cylinder is nearly filled with oil through a hole in the upper rear part. In case it is desired to empty the cylinder, there is a hole for the purpose in the lower forward end. Holes of a certain diameter are bored through the piston, and the recoil is checked in proportion to the resistance of the oil in passing through these holes. The cylinder not being quite full leaves an air-cushion to ease the strain. The piston-rod is secured to the carriage, and a slight vertical play is allowed in its fastenings to prevent the jump of the gun from bending it.

Carriage for Light Upper-Deck Guns.

The carriage consists of two $\frac{1}{2}$ -inch plate brackets connected by a bottom plate and transom. This carriage has no rollers. It is fitted with the elevating hand-wheel, pinion, and ratchet in use with the heavier calibre.† The toothed ratchet bolts to the side of the breech of the gun. The toothed edge of the ratchet gears to a pinion, while the back is supported by a

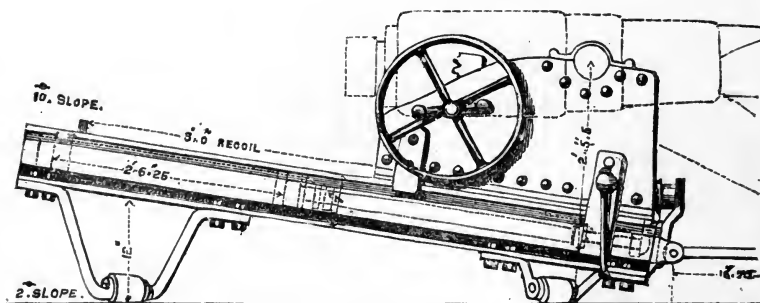

Slide for Light Upper-Deck Guns.

friction-roller attached to the bracket. The pinion being inside the bracket connects with a hand-wheel on the outside, which is held by a friction-brake. The peculiarity of the slide is that it slopes to the front at an angle of 10° . It is provided with a hydraulic recoil buffer (see Boat-Carriage), and also with plate compressors. There are two rubber buffers at the front of the slide to catch the gun in running out, and an in-tackle is fitted underneath the slide. A pivot-flap projects from the front of the slide, the pivot-bolt being close to the gun-port.

* See cut, page 203.

† See cut, page 199.

Carriage and Slide for 7-inch M. L. R.

The carriage is a single-plate one, having two brackets, two transoms, and a bottom plate assembled by angle-irons. The bottom plate is slotted for the Elswick compressor.* This com-

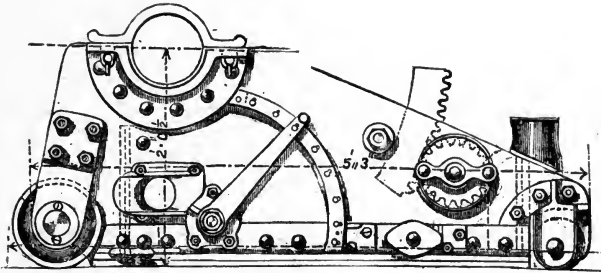

7-inch Carriage.

pressor is a modification of the American 15-inch one. It is made up of six bars of plate-iron, all of which are movable and which are placed lengthwise in the slide like the wooden balks in the American type. Seven plates hang through the slot in the bottom plate of the carriage, being loosely secured to it. The plates and bars are pressed together by rocking levers worked by screw-shafts, the shafts be-

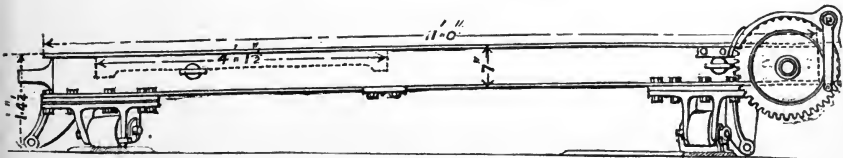

7-inch Slide.

ing worked by levers. The screws on the shafts are of different pitch. That on the right is called the compressing, having a quick pitch; when it is moved it presses the plates against the other lever, which, having a finer-pitched screw, is called the adjusting. The lower end of the adjusting lever is prolonged to form a trip-stop so that the recoil of the gun will throw the lever down automatically.

The front rollers of the carriage are permanently in action, whilst the rear ones are on eccentrics. The elevating-gear is the wheel and ratchet. The slide has a slope to the front of 3° . The slide-rollers are on eccentric axes. Attached to the rear of the slide is a simple system of winch-gear for running

* See cut, page 201.

in and training. This is nothing more than a spur-wheel and windlass revolved by a pinion and crank. In using it, the fall of the in-tackle or training-tackle is caught over the windlass which is turned by the crank. In revolving slides, or slides which shift from one port to another, there is a separate attachment under the forward end, which is nothing more than a centre roller which when thrown into action raises the forward rollers clear of the deck; the after-end of the slide being held by a pivot-bolt, the forward one is swung to a new pivot-centre. This centre roller is thrown into action by gearing. Two ordinary bollard-heads are attached to the rear of the slide, so that the carriage may be held back or veered out in a seaway by turns of the in-tackle falls about them.

Carriage and Slide for 8-inch M. L. R.

The carriage is similar to the 7-inch, except that instead of being fitted for tackles it is provided with Scott's nipping-gear and endless chain.* The chain is a slide attachment. The

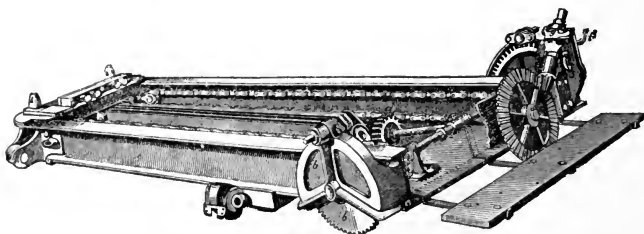

8-inch Slide.

nipping-gear consists of a heavy iron stirrup, movable in a vertical direction by means of an eccentric and lever. The chain passes freely through this stirrup when it is down, but on throwing it up the links of the chain are caught in the teeth of a sprocket-plate fastened to the bed-plate of the carriage, so that the movement of the chain carries the carriage with it. The slide is similar to the 7-inch, except that the Scott chain and gearing is used, which also traverses the slide. There are two chains, one at each side of the slide, which are revolved by pinions at either end. At the rear end the pinions are on a heavy axle, which is revolved by a crank and gearing. For training, this gearing is connected to a short shaft, having a pinion at its forward end, which gears in a metal rack on the deck; this shaft may be revolved or fixed at

* See cut, page 202.

will by means of a pawl-wheel and screw-break, so that in training the slide can be traversed or fixed as desired. When the slide is a shifting one, the same gearing is used to swing the forward end of it around, by means of another pinion which

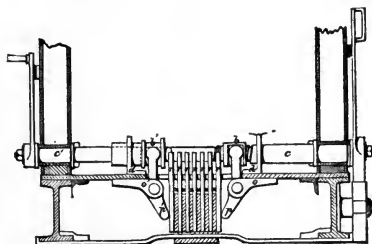

Elswick Compressor.

is shipped just in front of the forward end of the slide. The compressor is the Elswick pattern.

Carriage and Slide for 9-inch M. L. R.

The broadside 9-inch carriage is the same as the 8-inch; that for ships of the Sultan class differs in several particulars. The carriage is very low, its bottom plate coming well down inside of the slide. It is a double-plate carriage built on a

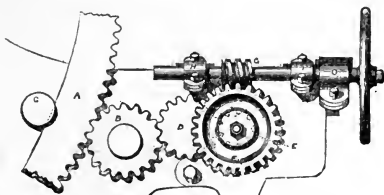

9-inch Elevating-Gear.

cast-iron frame, the outer plate coming to the top of the slide, whilst the inner one is carried down inside. The rollers are completely hidden in their recesses, the forward ones being permanently in action, whilst the rear ones are on eccentrics. The rear axle between the rollers is bent down so as to give room for the breech of the gun in elevating.

The compressor fitted to this carriage is called the bow-compressor. It consists, on each side, of a bow or cramp pivoted at the centre, so that one arm projects inside the carriage through the bracket. A hinged plate is secured to the inner end, while the outer one holds an adjusting-screw which is

worked by a hand-wheel, the latter having a pawl to hold it in any desired position. A brass arc near the face of this wheel graduated up to 17° shows the amount of compression. Two

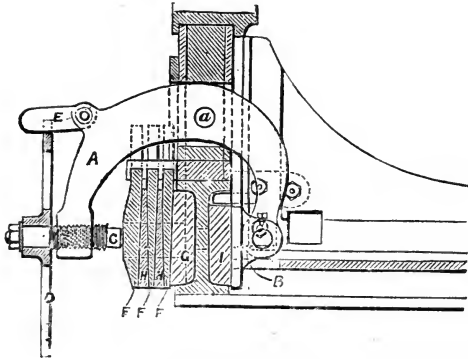

Bow-Compressor.

projecting pieces are attached to the side of the carriage to support the compressor-plates which hang upon them. These plates are three in number, the two inner ones being tapered, whilst the outer one is square-faced and much heavier. When the carriage is mounted on the slide, these tapering plates lie between the outer side of the slide (the T of which is filled out with wood) and two compressor-bars, which are tapered to correspond with the plates. The adjusting-screw takes against the outer plate, and by turning it the plates and bars are jammed together. The advantage of this compressor is that when once set it is self-acting, going out of action when the carriage is raised on its rear rollers, and coming into action by the weight of gun and carriage when the rollers are down.

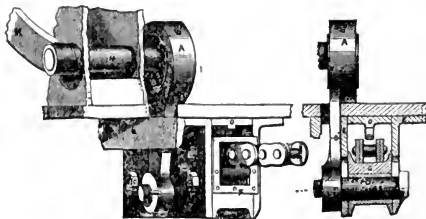

Scott Nipping-Gear.

The Scott nipping-gear is used, but it is single, the chain traversing the middle of the slide. The slide has no peculiarities except its height, which is greater than that of the 8-inch.

Carriage and Slide for 10-inch M. L. R.

The carriages for ships of the Sultan class are the same as those for the 9-inch, except that the rear rollers are thrown in action by means of a hydraulic jack attached to the left bracket, there being a capstan-head arrangement at the other end of the ax for use in case the jack should break down. (For turret-

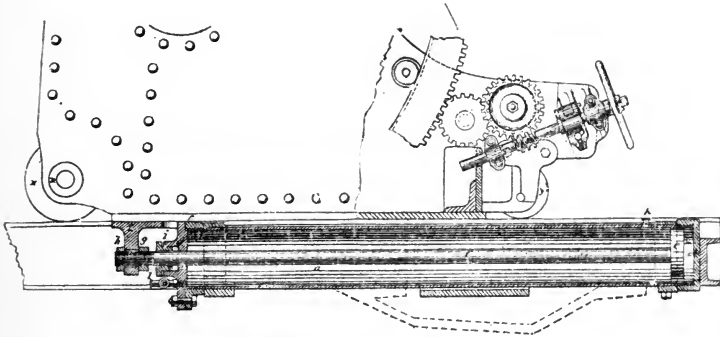

Hydraulic Recoil Compressor.

carriage, see turret-carriage of 11-inch.) The slide is similar to that of the 9-inch, except that instead of the bow-compressor two hydraulic recoil cylinders are used, one at each side of the slide.

Carriage and Slide for 11-inch M. L. R.

The carriages for ships of the Temeraire or Hotspur class are the same as the 9-inch ones. The turret-carriage is of the muzzle-pivoting type. This carriage presents the peculiarity

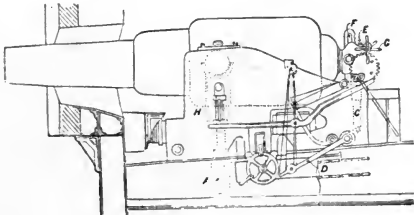

11-inch Small-Port Carriage.

of having one bracket larger than the other, in order to allow for the circular shape of the turret. The general frame of the

carriage is similar in shape to the ordinary type, being double plate on a cast-iron frame, with an interior wrought-iron frame which serves as a guide for the saddle. The gun is supported by the trunnions in a saddle which is nothing more than a massive fork, the leg of which is a hydraulic piston-rod. The arms, containing the trunnion-holes, are supported in the framework of the brackets. The hydraulic cylinder projects through and is secured to the bottom plate of the carriage, and the double-acting pump-brake is attached to a spindle passing through the bracket.

The gun does not rest permanently on the hydraulic, but when at the middle or top of its elevation the saddle-arms are supported by iron blocks, which are put in place through slits in the brackets. When the gun is down the saddle rests on the bottom of its slots. At the low level the gun gets 13° elevation, and at the high level 6° depression. The rear rollers are thrown in action by means of a double-acting hydraulic. The elevating-gear for this gun is different from that of the smaller calibres. Instead of having a curved ratchet attached to the gun, the ratchet in this case is pivoted to the carriage, and a gearing and traveller being clamped to the case of the gun, the breech elevates or depresses up and down the stationary ratchet. This carriage is provided with Scott's nipping-gear and the bow-compressor, the latter being heavier and double, working on both sides of the slide-plates. These carriages are provided with breechings which pass around a fitting bolted to the inside of the front transom. Additional hydraulic jacks are placed underneath the arms of the saddle for use in case the central one gives out. The slide is similar to the 10-inch, where traversing slides are used. In turrets the slide is a fixture. (See 12-inch slide.)

Carriage and Slide for 12-inch and 12½-inch M. L. R.

The carriage for turrets of the Devastation class is similar in general to that of the 11-inch. The hydraulic lift for the saddle is not a part of the carriage, however, but a part of the ship, there being two rams, one for raising the gun when run out, and one for raising it when run in. The elevating-gear is also different, in having an arrangement for altering the height of the stationary ratchet to correspond with the different levels of the trunnions. The slide is provided with hydraulic recoil cylinders, which also act as the running in and out power. The piston-head has no holes bored in it, but when the gun recoils the oil is driven out of the cylinder, the

flow being regulated by a balanced valve. The pump to move the hydraulic is worked by steam, the direction of the movement being controlled by a lever in the turret.

Carriage and Slide for 16-inch M. L. R.

There is no carriage proper for the 16-inch gun, the trunnions resting in saddles on beams fixed in the turret. Hydraulic piston-rods are attached to each saddle, the two cylinders being connected by a pipe to equalize the strain. The breech of the gun rests on a third block which travels in guides. These guides are hinged at the rear, the forward ends resting by means of a cross-head on the piston of a vertical hydraulic cylinder. By means of this the gun is elevated or depressed. The gun is run in or out, elevated, and loaded by hydraulic power.

Loading Arrangements.

With the lighter calibres and broadside guns the usual loading methods are used, the heavy charges and projectiles being transported by means of railways either on deck

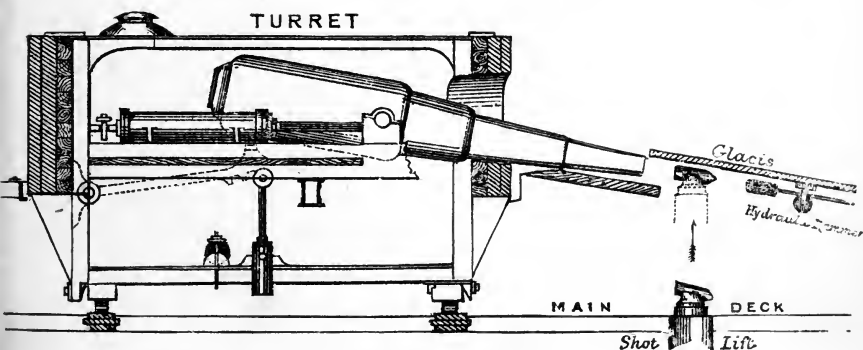

51-ton Gun-Slide and Trunnion Saddles—Hydraulic Loading Arrangements.

or under the beams (the projectile in the latter case being slung to a traveller), and raised to the muzzle of the gun by a small davit shipped at the proper point on the slide. With the heavy turret-guns, automatic loading is resorted to. To accomplish this, a hole the size of the bore of the gun is worked in the turret underneath the port. Athwartship openings are left in the turret casing of the main-deck, in front of which are placed a hydraulic lift and the hydraulic extension rammer. The gun being run in, the turret is re-

volved until the port comes over the station of the rammer. The muzzle is then depressed, and the gun started out until it rests at the loading-hole. The rammer, which is also the

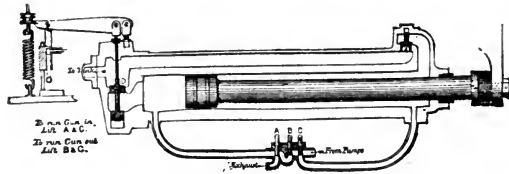

Hydraulic Recoil Press.

sponge, being fixed permanently at the proper angle, is started ahead by a lever and is pushed to the bottom of the bore. On bringing up, a small spring at one side of the rammer-head is pressed, which opens a valve and turns on a stream of water. The rammer being withdrawn, the charge is run up in a hand-car on to the hydraulic lift, by which it is raised to the muzzle. A wad is shipped on the head of the rammer, and the latter, being started ahead, pushes the charge home. Owing to the shape of the rammer-head, the valve-spring cannot be pressed in pushing the charge down, so there is no danger of turning on the water. The position of the rammer-head in the bore is denoted by a simple pointer worked by a string, the other end being attached to the rammer-head. This crude arrangement is frequently out of order, and but little attention was paid to it until its importance was brought forcibly into notice by the double loading and consequent explosion of one of the Thunderer's guns. One drawback to this system of loading is the care necessary to put the projectile on its car in one exact position, in order that the studs may come opposite their grooves. The car itself must be built at a certain fixed angle to bring the charge exactly in line for loading.

GUNPOWDER.

Gunpowder is graduated, according to size of grain and type, into seven distinct classes.

Service Pistol Powder is used for Colts' and Adams' pistols and for the bursting charges of shrapnel. It passes through a 44 and rests on a 72 mesh sieve.

Service R. F. G. Powder is used for rifled small-arms, except the Martini-Henry, Gatling guns, and pistols. It passes through a 12 and rests on a 20 mesh sieve. Density, 1.6.

Service R. F. G.² Powder is used for Martini-Henry rifles and Gatling guns. It is of the same size as the R. F. G., but greater density—1.72.

L. G. Powder is used in smooth-bores, and in rifled guns below 7 inches. This powder is being withdrawn as of inferior quality.

R. L. G. Powder is used for full charges in guns of 7 inches and upward where the weight of charge does not exceed forty pounds. It passes through the 4 and rests on the 8 mesh sieve.

P. Powder is used for battering-charges of all rifled guns of 7 inches and above, up to 12½ inches, and for all service charges of forty pounds and upward. The grain is cubical, $\frac{5}{8}$ of an inch on a side.

P.² Powder is used with the 12½-inch and upward. This powder is cubical, 1½ inches on a side.

Gunpowder is graduated according to its fitness for use into six classes:

CLASS I. *Service*.—All new powder. All returned powder found to be uninjured.

CLASS II. *Blank*.—Powder from broken-up cannon-charges too dusty for Class I. Powder from broken-up small-arm ammunition. Service powder found too dusty for use in cartridges.

CLASS III. *Shell*.—Powder found too dusty for Class II.

CLASS IV. *Doubtful*.—All powder returned into store and waiting examination.

CLASS V. *Condemned for Sale*.—Powder too much deteriorated for the higher classes.

CLASS VI. *Condemned for Extraction*.—Powder obtained from shells, and powder found to have been too much damaged for any use except for the extraction of the saltpetre.

CARTRIDGES.

Cartridge-bags are made either of serge or of silk cloth.

Serge is used in all smooth-bores and breech-loading rifles, except for the blank cartridges of smooth-bores, which are of silk.

Silk is used for all muzzle-loading rifles.

Cartridges are always filled by weight and not by measure.

All cartridges are both choked and hooped, the number of hoops depending on the length of the cartridge. These hoops are either of twine or braid, according to the size and weight of cartridge and the stiffness required.

All cartridges are marked in black with the nature of the gun for which they are intended, the weight of powder, and the monogram of the station where they were filled.

Cartridges are packed in magazines, in corrugated brass tanks which are either rectangular or pentagonal.

Cartridges for calibres above 8 inches are not transported about the ship's decks in passing-boxes, but in zinc cylinders with a lock cover.

PROJECTILES.

The projectiles used are shot, shell, shrapnel, and case-shot.

The Palliser chilled shot is used with the muzzle-loading guns of 7 inches and upward. It is of cast-iron, the head as far

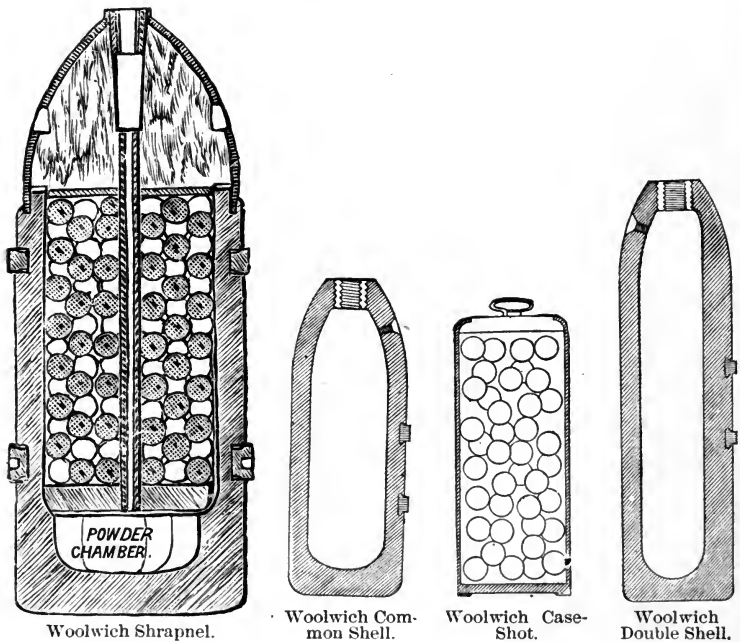

as the shoulder being cast in a chill, while the rest is in a sand-mould. This shot is never solid, but a space is left large enough to contain a bursting-charge if desirable. By this means a better casting is obtained. With the larger calibres, the cylindrical part of the shot is reduced slightly in diameter to allow for setting up when the projectile first starts. There are four kinds of shells: the segment, common, double, and Palliser. The segment shells are only used with breech-

loaders. This shell consists of a thin cast-iron cylindro-conoidal case lined with cast-iron segments built up in layers and leaving a cylindrical powder-chamber in the centre. The base is closed by a cast-iron disc. It is provided with a thin jacket of alloy, which takes in the rifling and gives the twist to the projectile.

The common shell is the ordinary cast-iron projectile. In addition to its fuse-hole it is provided with a loading-hole opening on the shoulder.

The double shell is similar to the common shell, except that it is nearly four calibres long and its chamber is provided with longitudinal strengthening ribs. It is only used in the 7-inch gun.



Zinc Passing-Box.

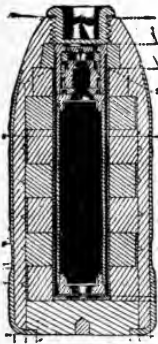

Armstrong Segment Shell.

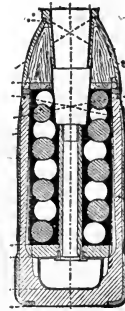

Armstrong Shrapnel.

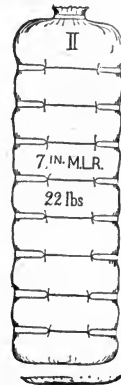

Woolwich Cartridge.

The Palliser shell is similar to the Palliser shot, except that it is slightly longer and has a larger chamber. Fuses are never used with the Palliser shot or shell.

The shrapnel consists of two main parts—the cast-iron body and the wooden head. The body is nearly as thick as that of the common shell, and is scored longitudinally in order to permit it to break up easily. The wooden head is covered with a light sheet-iron case which rivets to the body. The bottom of the chamber is the powder-chamber proper, over the mouth of which rests a wrought-iron disc having a hole in the centre, tapped to take a wrought-iron tube. The upper chamber is filled with lead bullets which are set fast with resin. The fuse screws into a hole in the head, and projects

into the wrought-iron tube communicating with the powder-chamber. Both the chamber and the tube are filled with powder.

Case-shot are of the ordinary form. Up to the 7-inch calibre the body is made of tin, beyond that it is of tinned sheet-iron. For the smaller calibres the bottom is of tin, for the larger it is a wrought-iron disc. The top is in all cases tinned iron. The contents of the case are packed in clay and sand, and there is an interior lining made up of three loose-fitting wrought-iron segments.

Shot and shell used with muzzle-loading rifles are now provided with a copper disc attached to the base, called a gas-check. This disc is slightly convex to the rear to enable it to spread and stop the windage on firing. It is attached to the projectile by means of a screw-plug and nut. On firing, it is expanded into the rifling and completely stops the windage. It gains a grip on the base of the shell by means of an undercut rim, whilst radial scores on the base prevent it from gaining an independent rotary motion, and enable it to assist in rotating the projectile.

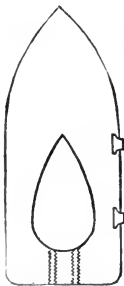

Palliser Shot.

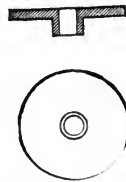

Papier-maché Wad.

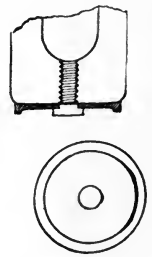
Brass Gas-Check
for Projectiles.

All muzzle-loading projectiles are provided with studs for rotation. They are of gun-metal, swedged into countersunk holes, in two rows. The loading side of all grooves is cut back so as to double the width of the groove at the muzzle, in order to facilitate the insertion of the projectile.

Papier-maché wads are used in front of the heavier projectiles to keep them from slipping forward out of place. These wads are very slightly less than the calibre of the gun, and about an inch in thickness. A hole is bored through the centre, large enough to leave a clear space for the fuse. A short papier-maché tube projects from the forward side of the wad, which serves to attach it to the rammer when loading, and hold it vertical while the charge is going home.

Shell-charges for Palliser projectiles are introduced in serge bags to prevent premature explosions.

FUSES.

Both time and percussion fuses are used in the navy. The time-fuses are the Boxer and the Armstrong; the latter used only with breech-loading segment shell. The percussion-fuse is the Pettman.

The Boxer time-fuse has a beech-wood body and is conical in shape. The fuse composition is a vertical column in a centre channel which is not bored entirely through the bottom, a base being left to receive the set-back of the column on firing. Two side channels are bored from the bottom nearly to the top, and are filled with mealed powder. Holes are bored from the outside into these channels one tenth of an inch apart, and the composition burns at the rate of one inch in five seconds, so that each hole represents a half-second. The head of the fuse is closed by a safety-cap, which is removed before loading. The time of burning is set by boring through the desired hole into the composition. The bottom hole is always bored through.

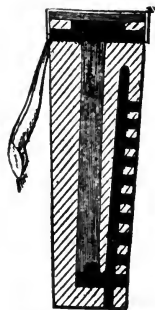

Boxer Time-Fuse.

The Armstrong time-fuse is made of gun-metal. A ring of fuse composition similar to that of the old Bormann fuse is pressed in a channel whose outer wall is marked in inches

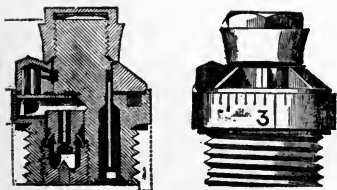

Armstrong Time-Fuse.



Armstrong Percussion-Fuse.

and tenths. This fuse composition is covered by a movable collar which is kept in place by a nut. Attached to this movable collar is a small chamber containing a detonator. When the gun is fired, this detonator ignites the composition at the point at which it is set, and the flame travels around until it

meets the magazine, or blowing-chamber, which communicates the flame to the shell-charge.

The Pettman percussion-fuse is made up of seven principal parts—the body, top plug, steady plug, detonating ball, cone plug, lead cap, and bottom plug. The top and bottom

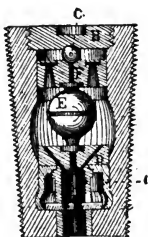

Pettman Percussion-Fuse.

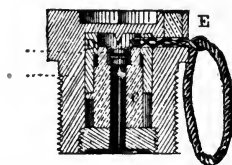

Laboratory Percussion-Fuse.

plugs are set fast; the shock of firing sets back all the other parts, crushing the lead cap over the cone and bottom plugs, which by their shape are all held fast when jammed together. The detonating ball, whose surface is covered with a detonating composition, is carried straight back and prevented from coming in contact with the sides of the chamber by the steady plug. When the projectile strikes, however, the steady plug starts forward and releases the ball, which, coming in contact with the sides of the fuse, explodes the detonating powder and the flame is carried by holes through the lower plugs to the charge.

PRIMERS.

Gun-locks are no longer used in the navy. Guns are fired by means of either the friction or the electric tube. The quill



Dummy Primer.



Electrical Primer.

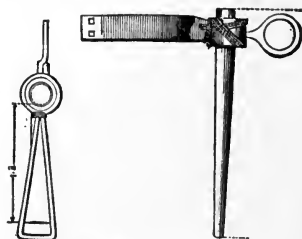

Quill Friction Primer.

friction-tube is used exclusively for the navy. This tube is of two sizes, the short and the long, the latter being used with the heavy calibres. The quill is driven with mealed powder, and a hole is pierced through the centre. The top and bottom

are stopped with shellac putty. In the upper part of the tube an iron-wire friction-bar is inserted, having a sprinkling of detonating composition and mealed powder on one side. The top of the tube is strengthened by a thread woolding and a leather loop, which slip over a pin placed forward of the vent.

The naval electric tube consists of a quill body and a xylo-nite bottom, the quill being of a diameter to slip completely into the vent. Within this quill are insulated terminals of

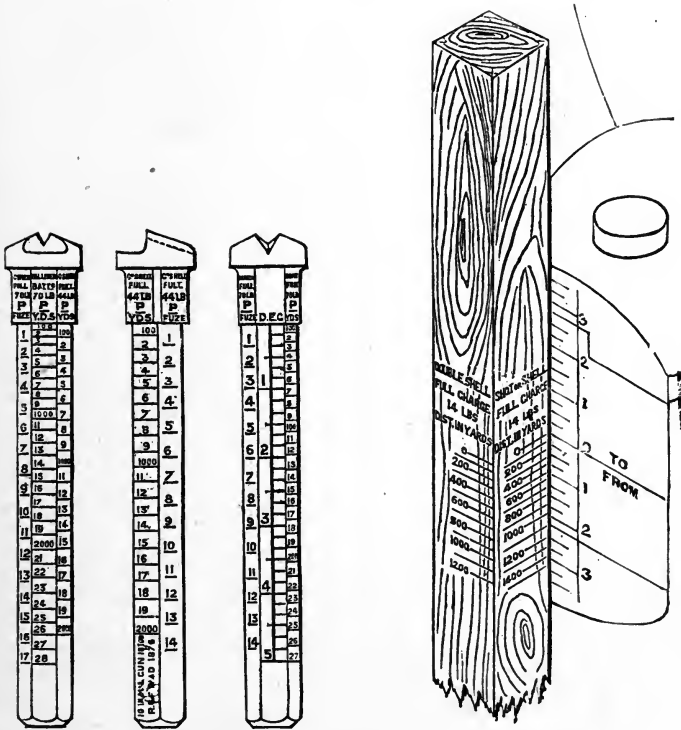

Centre Hind-Sight—Muzzle-Loaders.

Wood Scale.

wire connected by a platinum-silver wire bridge surrounded by priming composition. The whole tube goes into the vent, a stop on the insulating wires preventing it from going too far.

SIGHTS.

All muzzle-loading guns, except turret-guns and boat-guns, have six sights—three hind-sights (two tangent and

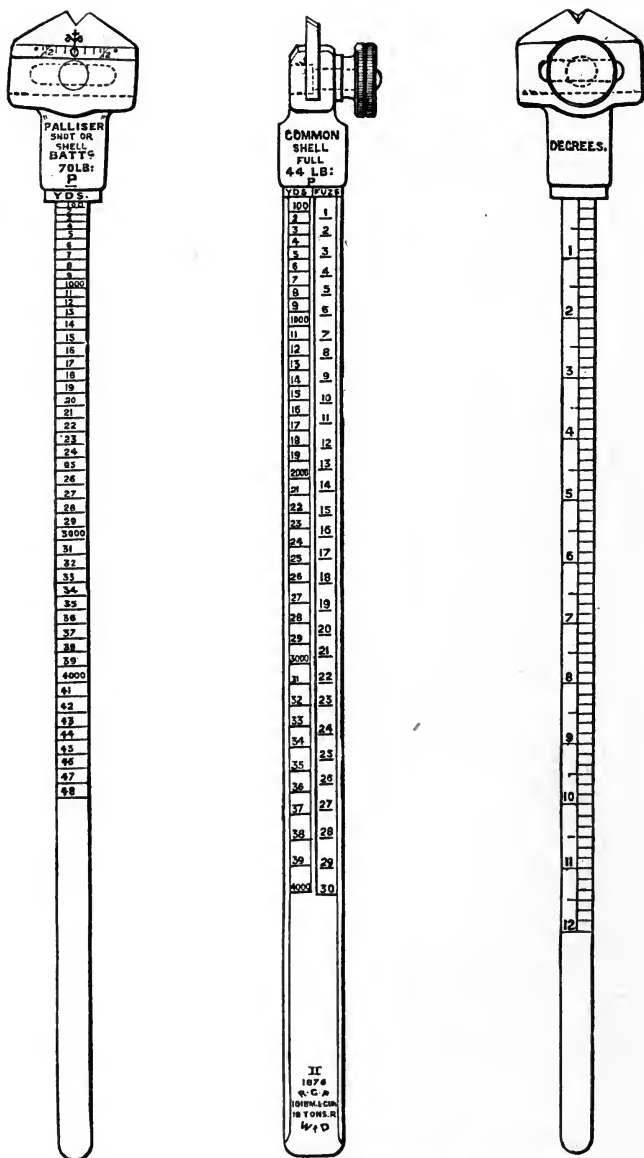

Sliding Leaf Tangent Sight—Muzzle-Loaders.

one centre) and three trunnion-sights. Boat-guns have one centre hind and one fore sight, and turret-guns have turret-sights. All guns except boat-guns have wood scales, and all

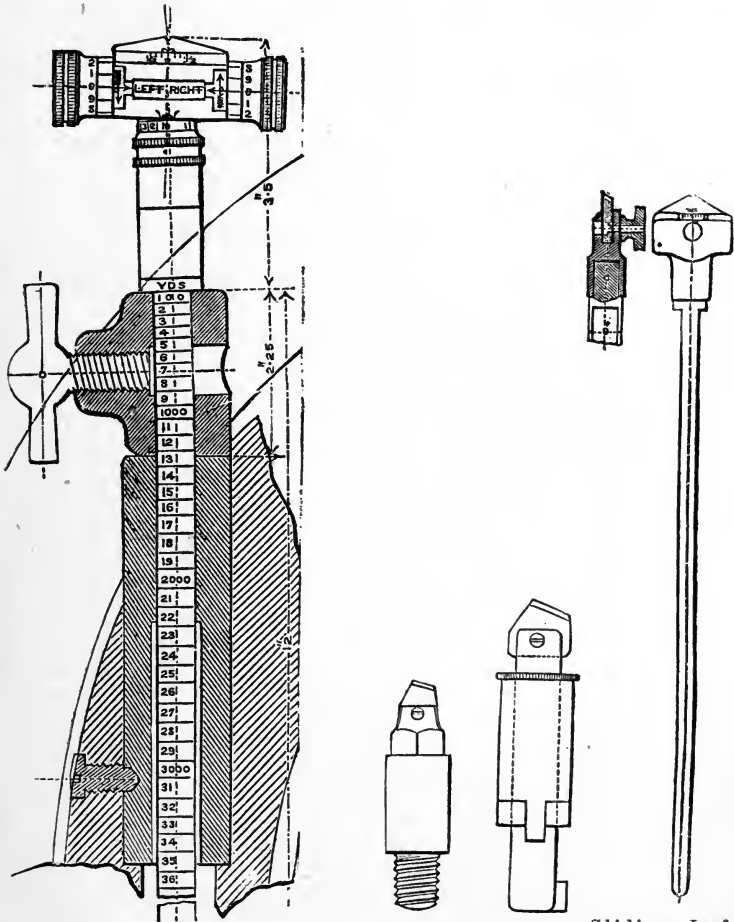

Barrel-Head Tangent-Sight—Breech-Loaders.

(Screw.) (Drop.)
Fore-Sight.

Sliding-Leaf
Tangent-Sight—
Breech-Loaders.

guns in covered batteries, except turret-guns, have graduated arcs on the pivot-circles.

The tangent-sight is a rectangular steel bar rounded off on two sides, and having a gun-metal head in which slides a gun-

metal leaf. The gun-metal leaf slides in a socket, and is provided with a simple clamp-screw. These sights are graduated on the four sides. In general, the forward side is graduated to 10' from 0 up to 12°. The right side is marked from 100 up to 4000 yards, and for seconds of fuse from 1 to 30—both graduations for common shell with the full charge; the rear side from 100 to 4800 yards for Palliser shot or shell with the battering-charge; the left side from 100 to 4800 yards, and from 1 second to 3½ seconds, for common shell with battering-charge.

The centre hind-sight is a hexagonal gun-metal bar with the sliding leaf marked like the tangent-sights, but shorter.

All hind-sights are set at a permanent angle of deflection.

The fore or trunnion sights consist of a pillar and collar of gun-metal, a small steel leaf, and a screw for fixing the leaf. A gun-metal socket is fixed in the gun, and the sight secured in this socket by a double bayonet-joint, so that it may be readily removed or replaced without requiring a special adjustment.

With turret-guns the sights are placed on top of the turret. Each turret is provided with a number of man-holes large enough to admit the head and shoulders. For each man-hole a pair of sights is adjusted, the line of sight being parallel to the axis of the gun. In some turrets, in order to prevent exposure, mirrors are arranged so that these sights may be used by persons in the turret.

The wood scale is a wooden bar used in connection with marks on the rear face of the cascabel. This face is marked from 0 to 3½° for both elevation and depression. The wood scale is a square bar having its four sides marked to yards for different charges. When the gun is placed in position aboard ship, this scale is cut so that its zero and the cascabel zero shall coincide with the guns at level, on an even keel.

The sights for breech-loaders are similar to those of muzzle-loaders, except that what is known as the barrel-headed sliding leaf is used, and there are no centre-sights.

DISTINGUISHING MARKS OF PROJECTILES.

The common shell is known from its carrying a fuse in the point which is cut off for that purpose.

The double shell is known by its disproportion of length to diameter.

The Palliser projectile is known from its sharp point.

The shrapnel is known from the joint which connects the head to the body.

Fragments of a copper disc would denote that Palliser projectiles were used, and a fragment of the head of a Palliser projectile is easily recognizable by the grain of the iron.

PALLISER CONSTRUCTION.

The Palliser construction is entirely applied to the conversion of old cast-iron smooth-bore guns into efficient rifles. In this system the bore of the gun is reamed out to a sufficient diameter to permit the insertion of a coiled wrought-iron tube. This tube is made up of a number of short coiled sections end-welded together. The rear of the tube is planed down, and a jacket (coiled with the spirals opposite in direction to the tube) is shrunk on. The breech end of the tube is closed by a wrought-iron disc screwed into place. The surface of the tube is then turned to a snug but not tight fit in the casing or gun, and is inserted, being held in place by a muzzle screw-collar. A screw is tapped through the chase into the tube to keep it from turning. The old vent is bored through and the gun is submitted to a course of proof-firing with full charges, to expand the tube against the wall of the casing, making a snug fit. A spiral slot is cut around the tube from front to rear, and carried through the cascabel

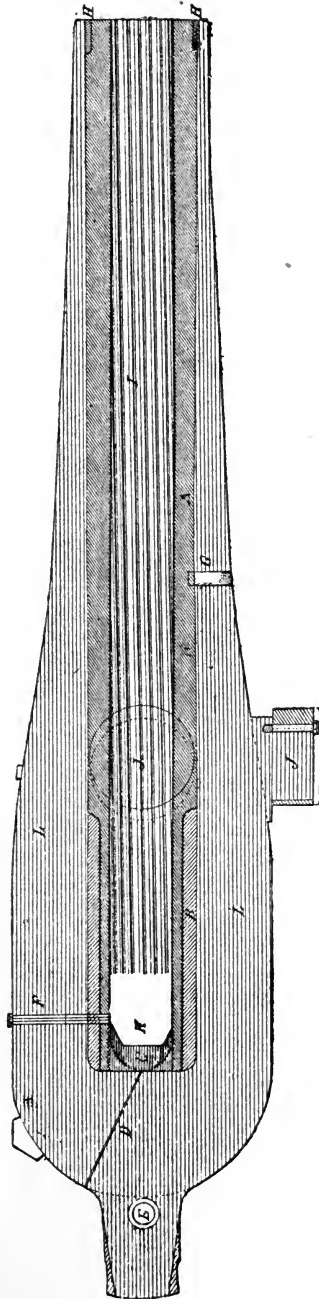

Palliser Converted Gun. (10-inch Rodman Smooth-Bore converted to an 8-inch Rifle.)

as a tell-tale for the escape of gas in case the tube is split or cracked through at a weld. These guns are extraordinarily long-lived, and have been extensively used by the governments of Great Britain and the United States.

Palliser Projectiles. See Pages 208–210.

WHITWORTH CONSTRUCTION.

Whitworth ordnance is used almost exclusively in the Brazilian Navy, and is the regulation type. The Whitworth con-

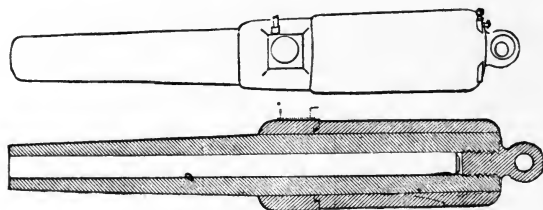

Whitworth Muzzle-Loader.

struction belongs to the all-steel type, and differs in almost every particular from the other types. The guns are both muzzle and breech loaders. The body of the gun consists of a steel tube reinforced by steel hoops. The tube is cast solid and submitted to a heavy hydraulic pressure while in a molten state, giving the metal as it solidifies a perfectly homogeneous crystallization throughout. This tube is bored completely through, and in the muzzle-loaders the breech end is closed by a steel screw-plug. The hoops are hollow cast and forged on a mandrel, the lengths in the different layers being accurately turned and screwed together; the layers are then put on the gun *cold*

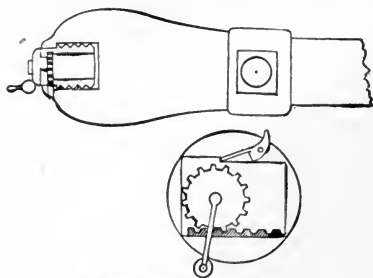

Whitworth Breech-Loader.

and forced home (from the muzzle end) by hydraulic pressure, the forcing being carefully gauged so as not to crush the metal of the tube.

The breech-loaders are slotted across the rear face in such a manner that the rear face of the block is entirely exposed, thus saving in length of breech of gun. The breech-block is cubical, and is traversed along the upper and lower surfaces by heavy threads set at an angle with the face of the block. These threads travel in heavy male threads in the slot, the system forming the support for the thrust on the block. Attached to the rear face of the block is a weighted crank which revolves a cogged wheel housed in the block and travelling in a rack in the rear of the lower side of the block-seat. In guns of heavy calibre the system is reversed, the crank and wheel housing in the rear of the gun and the rack in the block. By means of this gearing the block is moved transversely, masking and unmasking the bore, the left end of the block being cut for a loading-hole. A stop on the face of the breech locks the block when home and catches it at the proper point when open.

The Whitworth groove is of a peculiar nature, being almost

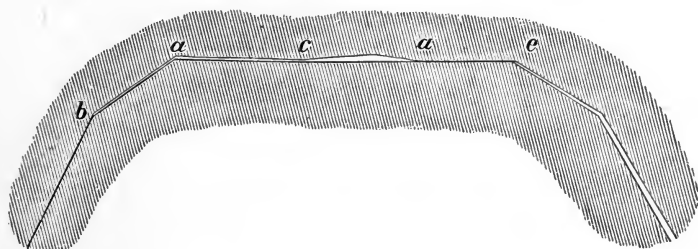

a perfect hexagon, and having an extremely sharp twist of from one turn in 2 feet in the 2-pdr. to one turn in 13 feet in the 9-inch.

The projectiles are cut to fit the grooves, the armor-punching ones being of compressed steel.

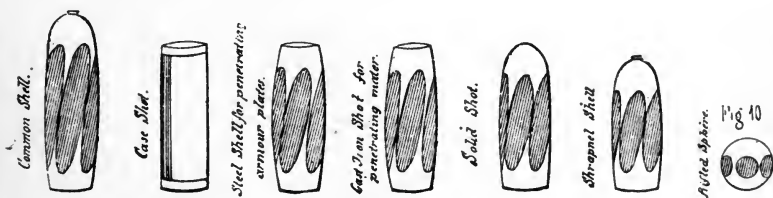

Whitworth Projectiles.

THE VAVASSEUR CONSTRUCTION.

Vavasseur ordnance is used considerably in China, and has found some use in other quarters of the world. The gun belongs to the steel type. It consists of a mild-steel oil-tempered

tube, reinforced by steel hoops, the hoops being narrow and numerous and shrunk on. The trunnion-hoop is of wrought iron. The gun has, properly speaking, ribs instead of grooves, the grooves being cut in the projectiles. The twist is a constant one.

The gun-carriage possesses a peculiar recoil arrangement, consisting of a heavy screw-shaft traversing the middle of the slide and carrying at its forward end a wrought-iron friction-wheel with a metal strap worked by a lever, by which any desired amount of friction may be applied. Attached to the carriage is a sleeve or clutch grasping the screw-shaft. When the gun recoils, the motion of the sleeve along the shaft causes the latter to revolve, the friction being regulated by the friction-

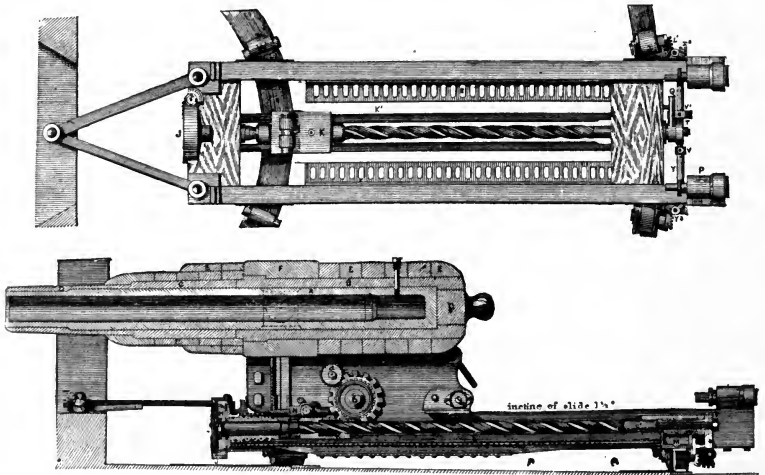

Vavasseur Gun and Carriage.

band. For running in and out a large cog-wheel is fixed to the inside of each carriage-bracket, the cogs taking in racks along the sides of the slide. In starting the gun out, the motion of starting slacks the friction-band on the screw-shaft, allowing the gun to run freely; for controlling the motion in a sea-way, a small friction-brake on the rear of the slide is used. The carriage is mounted on eccentric rollers, and the movement of throwing them out of or into action un gears or gears the running-out cranks outside of the brackets, so that in recoiling the cranks are not thrown around. The chamber of the Vavasseur gun, as originally constructed, is smaller than the bore, being in this a reversal of the present accepted true principle, and limiting the guns to small charges and low velocities.

FRENCH ORDNANCE—(CONTINUED.)

NAME, NATURE, AND CLASSIFICATION.	MUZZLE ENERGY.			PENETRATION.		REMARKS.	
	Steel.	Chilled.	Common.	Steel.	Chilled.		
	Ft. Tons.	Ft. Tons.	Ft. Tons.	In.	In.		
French pattern, cast-iron, steel-lined Breech-loaders.	Model of 1870.	32 cm.....	10,390	10,390	9,730	14.5	14.5
		27 ".....	6,596	6,596	6,506	12.5	12.5
		24 ".....	4,561	4,561	4,414	11.1	11.1
		19 ".....	2,330	2,330	1,828	9	9
		16 ".....	1,698	1,698	1,598	8.2	8.2
		14 ".....	712
	Model of 1864-67.	27 ".....	3,871	3,088	..	9.6
		24 ".....	2,821	2,144	..	8.75
		19 ".....	1,451	1,081	..	7.0
		16 ".....	876	687	..	5.87
		14 ".....	314
	Bronze Muzzle- loaders.	12 cm.....	176
		4 ".....	39
	Hotchkiss Machine-gun.....94	
Model of 1888-90 Muzzle- loaders.	22 cm.....	
	16 ".....	
	14 ".....	

FRENCH ORDNANCE—(CONTINUED.)

GUNS.

Smooth-bore guns are entirely obsolete, except for saluting purposes at dock-yards.

The rifled ordnance consists of the cast-iron breech-loader, model 1870, the cast-iron breech-loader, model 1864-67, the cast-iron muzzle-loader, model 1858-60, the bronze muzzle-loader, the mitrailleuse, and the Hotchkiss machine-gun. A new all-steel pattern is being introduced into the service, whose attachments are quite similar to the model of 1870.

The two models of breech-loaders differ radically in the style of rifling, and although the breech mechanism is the same in principle in both types, it is quite different in detail.

Breech-Loader, Model 1870.

Guns of this type consist of a cast-iron body strengthened by a steel tube and steel hoops. The steel tube, which is about

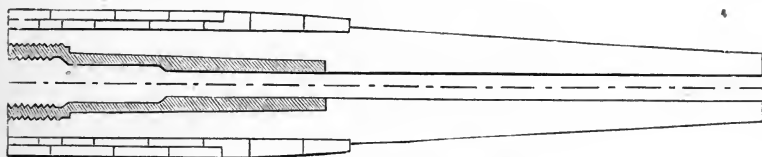

27-cm. French Gun, Model 1870.

one quarter of a calibre in thickness, is inserted into the bore from the rear, and is set fast by a heavy male screw-thread worked at its rear end. It extends a short distance forward of the trunnions. The steel hoops are shrunk on over the cast-iron body, and cover all that part occupied by the tube. For the 14-cm. calibre there is but one row of hoops; for the higher calibres two rows breaking joints. The trunnions form a part of the hoop next to the forward one. In all calibres above 16-cm. this trunnion-hoop is thicker than the others, and forms a salient on the surface of the gun.

The bore is rifled on the multigroove system, with an increasing twist of from 0° at the breech to 4° at the muzzle, the direction of the twist being from right to left (contrary to the invariable rule in other countries). The chamber proper is divided into four parts: the shot-chamber, the powder-chamber, the gas-check seat, and the breech-block seat.

The shot-chamber is conical in shape, small end forward, the rifling vanishing at this point in an easy slope. The di-

iameter of this end is the same as that of the bore measured across the grooves. The rear end is joined to the powder-chamber by a second small cone, against which the rear ring of the projectile takes when home.

The powder-chamber is cylindrical, and of a diameter slightly greater than that of the bore.

The gas-check seat is of considerably greater diameter than the powder-chamber. It is conical in shape, small end forward.

The breech-block seat is cylindrical, having a heavy screw-thread around its wall, which is cut into three equal sectors,

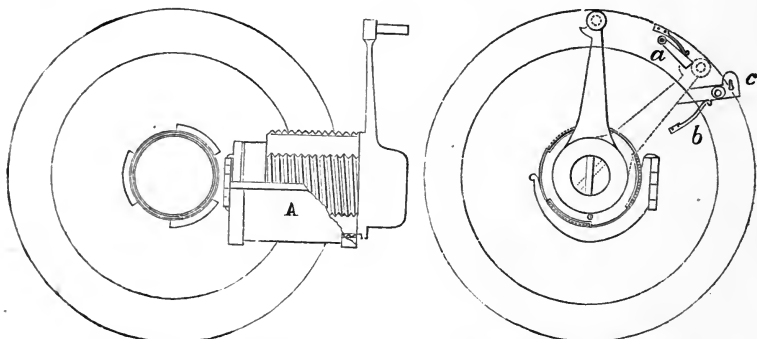

Breech-Block (Gun open).

Breech-Block (Gun closed).

leaving three blanks of the same width. One of these blanks comes at the bottom of the seat, in order to allow the breech-block to slide back and forth.

The breech mechanism consists of two main parts, the block and the console or bracket, which is hinged to the face of the breech and holds the block when it is withdrawn from its seat.

The breech-block is a steel cylinder having heavy screw-sectors about its surface to correspond with those in the seat. The last turn of screw-thread is left entire in order to relieve the shock of, closing the breech. The forward face is made movable in order that when it becomes worn and scored by the action of the powder-gas it may be changed.

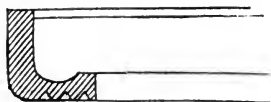

Gas-Check (1871).

This face is a steel disc which sets flat against the face of the block, and is of the same diameter. It seats in the face of the block by means of a smaller cylinder or trunnion, and projecting from the rear of this trunnion is a steel rod, which passes completely through the axis of the block and carries the vent. In order to prevent the disc from having any independent motion, a small tenon

on its rear face enters a socket in the face of the block. The disc is keyed fast by a small pin which is screwed radially through the block near the middle, the end of the pin taking in a score cut in the vent-rod. A small catch, projecting from the rear lower side of the block, holds the console in place when the breech is closed. The rear face of the block is provided with two parallel handles screwed to it, to assist in moving it, and a long crank-handle between them for revolving the block. At the end of this crank-handle there is a slight projection made to receive the blows of any instrument that may be used to drive the block around when it works stiffly. Along the two lower blanks of the block slots are cut, in which traverse small projections of the console to hold the block steady. About the middle of the lower screw-sector a small hole is cut into which a small stop springs when the block is withdrawn to its limit on the console. The vent is provided with a copper bush at its forward end and a steel one at its rear.

The console is semi-cylindrical, and is hinged to the face of the breech so that when the breech-block is withdrawn it may be swung to the right and unmask the bore. It is provided with a spring stop and two small projections taking in the block, which limit the movement of the latter and hold it steady when resting on the console.

Two small pins, screwed into the face of the breech, limit the arc of movement of the crank-handle, one at the vertical point and the other 60° to the right.

A small stop attached to the face of the breech holds the crank-handle fast when the breech is closed. This stop allows the handle to pass in closing, but must be raised by hand in opening.

The gas-check is of copper, and is a fixture in its seat. It is a ring in reality, the centre being cut out to permit the passage of the charge through it in loading; the edge is turned up, forming a cup, the outer part being conical to fit the seat. The bend of the rim is quite thick, and a gutter is cut around it in order to make the powder-gas seal the joint properly. The bottom of this ring is provided with three concentric grooves to break the force of the gas that may escape through the joints. When the breech is closed the face of the block presses directly on the gas-check, and a copper ring is countersunk in the face of the block which forms the contact with the check. This ring has grooves to correspond with the grooves on the back of the gas-check.

The vent is horizontal, and is situated in the axis of the breech-block. Its outer end is formed in double-cone shape (throughout the steel bush), the small ends of the cone being

iameter of this end is the same as that of the bore measured across the grooves. The rear end is joined to the powder-chamber by a second small cone, against which the rear ring of the projectile takes when home.

The powder-chamber is cylindrical, and of a diameter slightly greater than that of the bore.

The gas-check seat is of considerably greater diameter than the powder-chamber. It is conical in shape, small end forward.

The breech-block seat is cylindrical, having a heavy screw-thread around its wall, which is cut into three equal sectors,

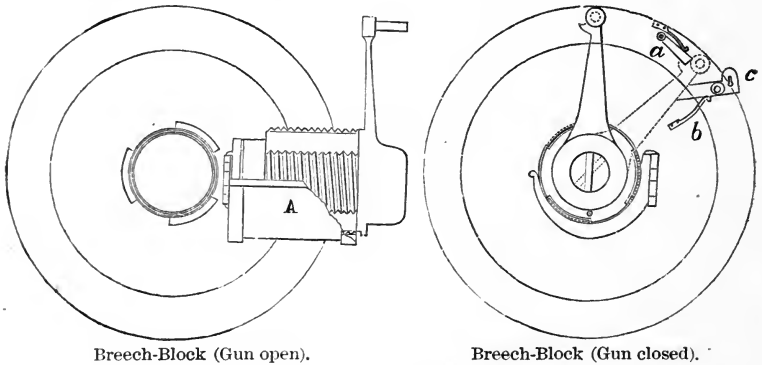

Breech-Block (Gun open).

Breech-Block (Gun closed).

leaving three blanks of the same width. One of these blanks comes at the bottom of the seat, in order to allow the breech-block to slide back and forth.

The breech mechanism consists of two main parts, the block and the console or bracket, which is hinged to the face of the breech and holds the block when it is withdrawn from its seat.

The breech-block is a steel cylinder having heavy screw-sectors about its surface to correspond with those in the seat. The last turn of screw-thread is left entire in order to relieve the shock of, closing the breech. The forward face is made movable in order that when it be-

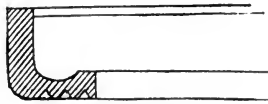

Gas-Check (1871).

comes worn and scored by the action of the powder-gas it may be changed. This face is a steel disc which sets flat against the face of the block, and is of the same diameter. It seats in the face of the block by means of a smaller cylinder or trunnion, and projecting from the rear of this trunnion is a steel rod, which passes completely through the axis of the block and carries the vent. In order to prevent the disc from having any independent motion, a small tenon

on its rear face enters a socket in the face of the block. The disc is keyed fast by a small pin which is screwed radially through the block near the middle, the end of the pin taking in a score cut in the vent-rod. A small catch, projecting from the rear lower side of the block, holds the console in place when the breech is closed. The rear face of the block is provided with two parallel handles screwed to it, to assist in moving it, and a long crank-handle between them for revolving the block. At the end of this crank-handle there is a slight projection made to receive the blows of any instrument that may be used to drive the block around when it works stiffly. Along the two lower blanks of the block slots are cut, in which traverse small projections of the console to hold the block steady. About the middle of the lower screw-sector a small hole is cut into which a small stop springs when the block is withdrawn to its limit on the console. The vent is provided with a copper bush at its forward end and a steel one at its rear.

The console is semi-cylindrical, and is hinged to the face of the breech so that when the breech-block is withdrawn it may be swung to the right and unmask the bore. It is provided with a spring stop and two small projections taking in the block, which limit the movement of the latter and hold it steady when resting on the console.

Two small pins, screwed into the face of the breech, limit the arc of movement of the crank-handle, one at the vertical point and the other 60° to the right.

A small stop attached to the face of the breech holds the crank-handle fast when the breech is closed. This stop allows the handle to pass in closing, but must be raised by hand in opening.

The gas-check is of copper, and is a fixture in its seat. It is a ring in reality, the centre being cut out to permit the passage of the charge through it in loading; the edge is turned up, forming a cup, the outer part being conical to fit the seat. The bend of the rim is quite thick, and a gutter is cut around it in order to make the powder-gas seal the joint properly. The bottom of this ring is provided with three concentric grooves to break the force of the gas that may escape through the joints. When the breech is closed the face of the block presses directly on the gas-check, and a copper ring is countersunk in the face of the block which forms the contact with the check. This ring has grooves to correspond with the grooves on the back of the gas-check.

The vent is horizontal, and is situated in the axis of the breech-block. Its outer end is formed in double-cone shape (throughout the steel bush), the small ends of the cone being

joined. Percussion primers are used in connection with a spring gun-lock. (See Primers.)

Breech-Loader, Model 1864-67.

These guns are hooped like the model of 1870, but are not tubed.



14-cm. French Gun.

The vent is pierced vertically near the bottom of the powder-chamber, instead of being in the breech-block.

The grooves are of the pattern known as the "basket-handle," for mechanical fit projectiles (see French Groove, English

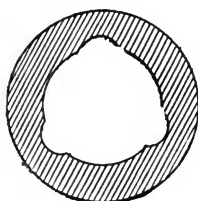

Groove (1864).

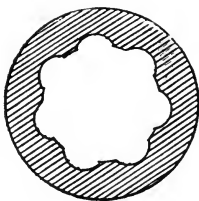

Groove (1871).

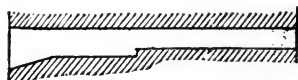

Rear end of Groove (1864), showing Stop for Projectile.

Ordnance), having an increasing twist of from 0° to 6° . The 14-cm. and 16-cm. guns have three grooves, the others five. The width of the grooves is the same throughout the length of the bore, being cut back on the loading side near the powder-chamber to facilitate loading. The depth of the groove, however, diminishes towards the muzzle in order to pinch the studs and steady the projectile. At the powder-chamber and running forward for a short distance in the centre of each band is a supplementary groove, in which travel the rear studs of the projectiles, which are made so small as to easily shear off. These secondary grooves prevent the projectile from being pushed too far into the bore. With the 19-cm. gun, the supplementary groove is made by cutting back the loading side of the regular groove. There is no shot-chamber proper.

The powder-chamber is cylindrical, of the same diameter as that of the bore across the grooves. The bottom groove is produced through the powder-chamber, to serve as a directing groove for the projectile in loading.

In rear of the powder-chamber there are two gas-check seats, conical in shape, with the small diameter forward. The

rear and larger one is intended for service in case of accident to the other.

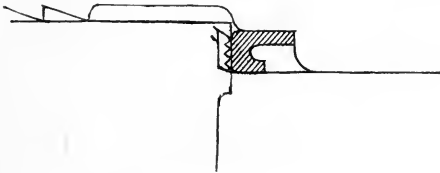

Gas-Check (1864).

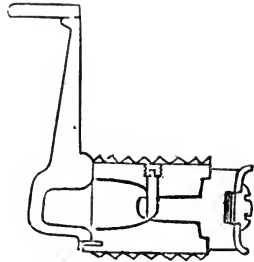

Breech-Block (Section).

The breech-plug seat is similar to the model 1870.

The breech-closing mechanism consists of two main parts like that of the model 1870, the breech-plug and the console or bracket.

The breech-plug differs from the model 1870 in being lighter, by having the interior cut away as much as possible consistent with strength. It has two movable faces or discs to correspond with the two gas-check seats. These discs are secured to the face of the plug in a similar manner to the model 1870, except that the disc in this case is allowed to revolve freely. The gas-check is carried on the face of the disc instead of being a fixture of the gun.

It is quite similar to the model 1870, except that the hole in the centre is smaller and serves to secure it to the face of the disc. The centre of the disc being slightly raised carries two ears which receive the inner edge of the gas-check and centre it. Over these a solid-headed nut screws, which fixes the gas-check and makes a tight joint. The gas-check is made of steel.

The console is similar to the model 1870.

Muzzle-Loader, Model 1858-60.

These guns are hooped, but have no tubes. The trunnions are cast with the body of the gun, the hoops not coming so far forward. The vent is vertical near the bottom of the powder-chamber, like the model 1864.

The grooves are of the "basket-handle" type, three in number, with an increasing twist of from 0° to 6° . These grooves, near the chamber, are cut back and prolonged to form seats for the rear studs.

All guns of this model are converted from old smooth-bores.

Bronze Muzzle-Loader.

These guns are of the ordinary bronze type. The 23-pdr. (canon de 12) has six common grooves having a *regular* twist from *left* to *right*. The bottom groove is narrowed on the loading side near the powder-chamber in order to force the studs into close contact with the driving side. The 8-pdr. (canon de 4) has six grooves with a regular twist similar to the 23-pdr.

The vent is pierced vertically near the bottom of the powder-chamber.

The Mitrailleuse.

The exterior of the mitrailleuse has the appearance of a bronze cannon. This case encloses 25 rifled tubes brazed together. The rear part of the cannon presents a vertical cavity, very large and nearly rectangular in shape. This cavity is called the cage, and is intended to receive the breech-block and firing mechanism. The breech-block is a cubical block containing prolongations of the 25 barrels which serve as chambers for the cartridges. When loaded, this block drops into the forward part of the cage. The lock mechanism is a box containing 25 firing-pins, arranged with guides and springs on the ordinary system. This box is movable longitudinally by the motion of a breech-screw, which also sets up the breech-block when in place. The motion forward of this box retracts the firing-pins, which are then held until released in rapid succession by a turn of the crank. After firing, the breech-screw is backed, the block taken out and a loaded one is put in its place, the screw is set up retracting the locks, and the piece is ready for firing again.

Hotchkiss Machine-Gun.

(See United States Ordnance.) This gun is an American invention, but was first introduced into the French Navy.

CARRIAGES.

Gun-carriages in the French Navy are classified as follows:
Slide-carriages for heavy broadside-guns.

Turret-carriages and revolving-slide carriages for heavy guns.

Directing-bar carriages for broadside-guns.

Four-truck and rear-chock carriages for broadside-guns.

Gun-boat carriages for bronze guns.
 Boat-carriages for bronze guns.
 Mountain carriages for bronze guns.
 Mitrailleuse saddle or fork for machine-guns.

Slide-Carriage for 27-cm. and 24-cm. Guns.

The rails of the slide are of heavy double T iron, connected by T and plate iron transoms. The slide rests on a pair of conical rollers, with concentric axles forward and a double pair of rear rollers (concentric) at the rear. The forward pair of the rear rollers and the front rollers travel on smooth tracks, while the rear pair of rollers are pinions working in a rack on deck. The slide is traversed by tackles, except in fine pointing, when levers are shipped on the rear rollers and the fine traversing is done by heaving on them. A pawl working on the rear rollers secures the slide in any desired position. The recoil is checked by friction compressors. There are eight iron compressor-bars on each side of the slide, just inside of the rails, resting on the front and rear transoms. On top of the front transom is a heavy iron dumb-sheave, which receives the bight of a rope breeching. The carriage is of the ordinary form of double plate, mounted on rollers, the forward pair being in permanent action and the rear pair on eccentric axles. Tackles are used for running out and in. The compressor-plates are nine in number on each side, suspended on an axle. The outer plates are heavier than the others. The ones next to the brackets are backed by steel disc-springs. Rocking levers working in screw-threads on the axle press against the inner plates. The levers are worked by a ratchet-lever on the exterior right side,



Elevating-Gear and Compressor, 24-cm. Gun.

this lever being provided with a trip for throwing it down automatically in firing. Railway buffers are placed at the rear of the slide to act in case of over-recoil. The elevating-gear con-

sists of a flat-linked chain passing underneath and supporting the breech of the gun. The ends of the chain wind about axles in the carriage-brackets, the axles being revolved by endless-screw gearing. Levers for turning this gearing ship outside the brackets. In elevating or depressing, it is necessary to turn the gearing alike on both sides in order to keep the centre link, which is marked, in its place under the breech. In elevating, the gearing must be worked slowly in order to allow the breech to follow down by its preponderance. With the 24-cm. gun, the compressor-plates, 12 in number, are all in the centre instead of being at the sides.

Slide-Carriage for 19-cm. Gun.

The fixtures for the slide and carriage differ in several particulars from the heavier ones. The slide travels on four *pairs* of rollers, the rear rollers of the rear pairs being cogged for fine pointing as in the heavier ones. The slide rests on iron pillars with screw-threads at the upper extremities, the lower ones resting on the axles between the rollers, forming a pair. The threaded top has a capstan-head, so that, by turning, the front or rear of the slide may be elevated or depressed. These rollers are also arranged for transporting the slide from port to port. For this they may be turned to run in the desired direction, similar to the principle of chair-rollers (casters). Clamps are provided to hold them in the desired position.



Slide-Truck
for 19-cm.
Gun.

The carriage has only one in-tackle. The rocking-lever compressor is changed to the ordinary bow-compressor. (See English Ordnance, Compressor for wooden-slide carriages.)

*Turret-Carriage and Slide for Heavy Guns.**

The turret-slide, instead of being provided with rollers for traversing, is mounted on a centre-pivoting turn-table. The turret itself is fixed, the gun firing over it "en barbette." The turn-table is mounted on sixteen conical rollers, and is revolved by means of a fixed rack, to which gears a pinion worked by a crank attachment on the slide. This attachment consists of a horizontal axle revolving in bearings through the rear of the slide-plates, having a crank at each end and a chain-wheel in the middle. An endless chain transmits the motion to gearing

* See plate Part IV. French Barbette Turret.

at the forward end of the slide, which connects with the rack on the floor of the turret. A locking arrangement holds the turn-table in the desired direction. The slide resting on its supports rises to a much greater height than with broadside-carriages, and is provided with a short stairway from the turn-table to the slide-top. The carriage is similar to the ones heretofore described, except that extra gearing is applied to the elevating apparatus to enable it to be reached by the men standing on the turn-table. Chain-gear similar to Scott's in and out gear is used with the carriage. Instead of a movable stirrup used to catch the chain, the upper part passes through a slit in the rear transom of the carriage, so that when the rear trucks are thrown in action teeth in it catch the chain. The same style of compressor is used as is found with the 24-cm. carriage



Additional Gearing for Elevating-Gear of Turret-Carriage.

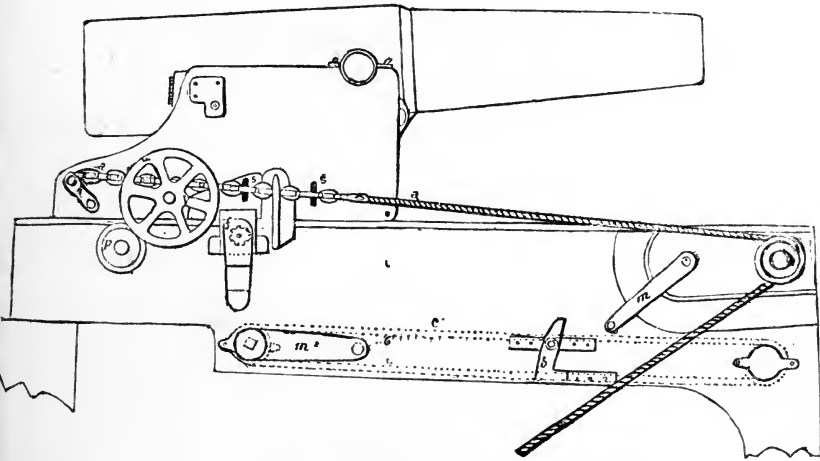

Barbette Turret-Carriage.

previously described, except for the 19-cm. gun, which has the ordinary cramp-compressor.

Revolving-Slide Carriage.

The slide is a centre-pivot resting on a circular track and on four rollers. It is traversed by a crank revolving gearing which works in a circular rack around the outside of the roller-circle.

The carriage is similar to the ordinary type, except that it is much higher, in order to allow a greater angle of depression to the gun. Instead of in and out tackles, a runner is used which passes over a windlass fixed on the rear slide-transom. This

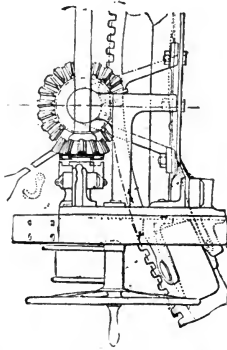

Training-Gear for Centre-Pivot.

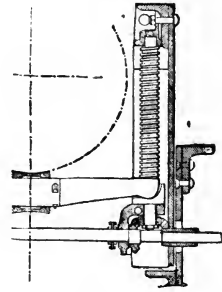

Elevating-Gear for Centre-Pivot Carriage.

runner throws the rear trucks in action, and then, according to its lead, runs the gun in or out. The elevating-gear for the 16-cm. gun consists of a heavy cross-bar underneath the breech, having sleeves at the extremities which clasp heavy upright screws. By revolving these screws, the bar is carried up or down. The elevating-gear for the 14-cm. gun is the old-fashioned telescopic elevating-screw.

Directing-Bar Carriage.

The carriage proper is of the ordinary rear-chock or Marsilly type, which when run out for firing is lifted from the deck on a slide or chariot, so that it may be easily and quickly trained. The chariot consists of a broad, short front-piece, mounted on two rollers; projecting forward from it is a pivot-flap which secures by a pivot-bolt just underneath the port, the rollers being canted for traversing about the pivot. Projecting to the rear from this front-piece is a tongue made of T iron, which is supported at its rear end on two trucks which are canted like the forward ones for traversing. When the carriage is run in, its rear end comes flush with the end of this tongue, and the forward trucks rest on the deck. In running out, however, two small rollers on the axle, inside of the brackets, catch on and mount two inclined planes which slope back from the top rear of the chariot, thus lifting the carriage completely from

the deck. A breeching is used with this carriage, its bight going around a B block on the front of the chariot. There is also a friction compressor at the rear of the brackets, the compressor plates taking against the sides of the T iron, which are filled out with wood for that purpose. The forward edge of the B block serves as a hurter in running out. In all other respects the carriage is similar to the ordinary broadside rear-chock carriage. It is used on upper decks of large ships for light guns.

*Four-Truck Carriage
and Rear-Chock
Carriage.*

These are of the general type of old-fashioned wooden carriages.

*Gun-Boat Carriages
and Boat-Carriages.*

These carriages are of the old-fashioned type. The former is the slide pattern, its only peculiarity being that its forward and rear rollers can be revolved for transportation on a vertical pivot. The carriage has no rear trucks.

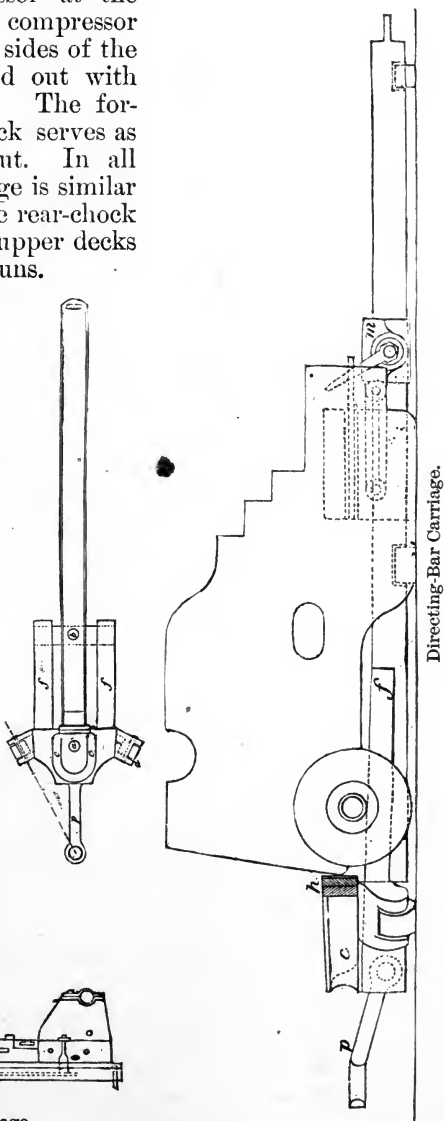

Boat-Carriage.

The carriage is provided with holding-down clips, and the recoil is checked by a breeching whose ends are made fast to

the brackets, the bight passing around a bollard on the forward transom of the slide.

Mountain-Carriage.

The mountain-carriage is similar to the English field-carriage except the elevating-gear, which consists of a plain elevating-screw to which a hand-wheel and pinion gear.

Mitrailleuse Saddle.

This consists of a pillar whose lower end ships in a socket in the ship's rail, and whose upper end branches into a fork to support the trunnions. A longitudinal support projects from the pillar, which holds a pivoted arm by means of a clamp. This gives a quick motion for elevating or depressing. The end of the pivoted arm holds an ordinary elevating-screw for slow motion.

Hotchkiss Saddle. See United States Gun-Carriages.

GUNPOWDER.

The gunpowder used in the French service is classified according to the size of grain.

Wetteren powder, named from the place of manufacture in Belgium, is a large-grained cubical powder used in guns of the model 1870.

Ripault powder, named from its place of manufacture in France, is an ordinary-sized cannon powder used in all guns except the above.

Hunting powder is a small-grained, highly-glazed powder used in revolver cartridges.

B powder, of a slightly larger grain than the hunting, is used in Chassepot rifle cartridges.

Musket powder is used in the manufacture of primers, fuses, and signals.

CARTRIDGES.

Cartridge-bags are made either of parchment or serge. For the smaller calibres they are of parchment.

Each cartridge is marked in black with the calibre of the gun for which it is intended, the weight of charge, monogram of the place where it was filled, and date of filling.

Cartridges are kept aboard ship in brass or copper tanks of various forms having water-tight covers.

PROJECTILES.

The projectiles used in the French Navy are shot, shell and case-shot. There are two kinds of shot, cylindrical and ogivo-cylindrical, corresponding to the shape of the head; the cylindrical being used only in the calibres above 19 cm. They are all steel. The ogivo-cylindrical shot are used in all calibres above 14 cm., and are either of steel or chilled cast-iron. Shell are of cast-iron, and are similar in shape to the ogival shot.

These projectiles are differently mounted for the different models. For the model 1870 the mounting consists of a forward ring of zinc or cast-iron just back of the shoulder of the shell, slightly smaller than the diameter of the bore across the

Projectiles, Model 1864.

Projectiles, Model 1870.

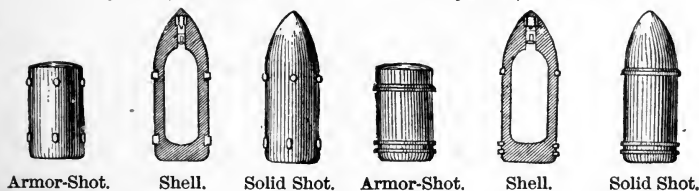

lands. Its object is simply to keep the forward end of the projectile centred. A rear ring of copper, of a diameter slightly greater than that of the bore across the grooves. This ring brings up in its seat in the shot-chamber, and on firing the bands are scored and rotate the projectile. Around the surface of this ring are two or three grooves, cut to receive the metal displaced by the lands on firing. These projectiles carry at their base a light wire grommet to facilitate handling them.

For the model 1864-67 the projectiles are provided with studs, there being two rows. The forward studs take in the grooves and give the twist to the projectile; the rear ones hold the base of the projectile centred, and according to the calibre of the piece they travel in the grooves or on the lands. For the heavy projectiles, where the rear studs travel on the lands, there are provided three small intermediate studs which bring up in false grooves provided for the purpose, keeping the projectile from going too far forward in the bore when loading. These studs are sheared off on firing. The studs are made either of zinc or bronze. Projectiles for the bronze muzzle-loaders are similar to the model 1864.

Case-shot are of the ordinary type, and have neither studs nor belts.

Sea-weed wads are used with all projectiles except those of the model 1870. These are used in order that the powder-charge may act with a more gradual effect on the projectile at the start. Placed between the charge and the projectile, their rapid compression gives room for the powder to expand and burn more slowly at the first instant.

FUSES.

Percussion-fuses are used in all shell except the 25-pdr. and 8-pdr. boat-guns, which use time-fuses.

The percussion-fuse consists of a hollow cylindrical bronze body having a solid conical head. At the bottom of the cylinder is screwed a copper firing-pin. The centre of the cylinder is occupied by a brass plunger carrying a charge of hunting powder. The forward end of this plunger carries a wooden plug which is hollow and filled with detonating composition. The plunger is held in position by two iron pins upon which the base rests, and two leaden stops through the wall of the fuse entering the shell of the plunger. These stops are not broken by the start of the projectile, but by its shock on striking an object. The bottom of the fuse, being covered by shellac-paper, is blown away by the charge of powder in the plunger, and the flame is communicated to the charge.

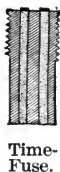
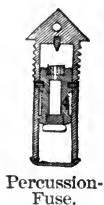

The time-fuse for boat-guns consists of a brass body having two longitudinal chambers for fuse-composition columns of different times of burning. For the 23-pdr. the times correspond to 1500 and 3000 metres; for the 8-pdr. they correspond to 1100 and 2200 metres. The longer column is always uncapped on loading. The different times are distinguishable by the difference in the caps. That for the long time is of wire; for the short time it is of leather covered with a red wafer.

PRIMERS.

The primers are of two kinds, percussion and friction. The former seal the vent entirely on firing, and are only used in guns having vents through the breech-block (Model 1870). Friction primers are used in all guns having vertical vents.

The percussion primer consists of a body of brass or copper, slightly conical and having a solid head. Into this body screws a small steel anvil carrying an ordinary percussion-cap, which, when the anvil is screwed home, bears against the primer-head. The remainder of the body is filled with fine hunting powder, and the bottom is closed by a shellacked wafer.

The friction primer consists of two quill tubes, the lower and larger one being filled with fine musket powder, the bottom being sealed with wax. The upper is filled with fulminating composition, and has passing through its centre a brass friction-wire corrugated along its length. The exterior of the wire is formed in a loop for hooking on the firing lanyard. The upper part of the primer is closed by a block of wood forming a fairleader for the friction-wire. A small independent loop is attached to the head of the primer, by which it may be withdrawn from the vent without touching the friction-wire.

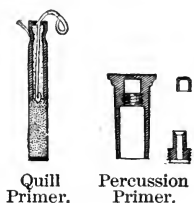

SIGHTS.

The sights used in the French Navy are all side-sights, and for the most part the tangent-sights are inclined at a permanent angle.

The front-sights are conical in shape, and are screwed into the rim-bases.

The tangent-sights are square in section, working in boxes screwed to the face of the breech. They are graduated to full and half cable-lengths (200 and 100 metres). As a rule, guns are sighted on the left side, although provision is made for a right tangent and front sight. Sights are graduated on the left side for shell and on the right for shot, the graduations being all carried across the rear face. In general there is a short and a long sight, the long one being used for distances greater than 30 cables (6000 metres).

ACCESSORIES.

The loading-plate is a plate which attaches to the breech of the gun when the breech-block is open; along the bottom of this plate is a groove which forms a prolongation of the bottom groove of the gun (not applicable to model 1870); the projectile being hoisted to the level of the bore is landed on this plate, and is then in position to be rammed home. For

small projectiles this plate serves as a shell-bearer for transporting projectiles, being provided with side handles.

The shell is brought to the loading-plate on covered decks by means of a tackle appended to a roller working on a traveller. The projectile being hoisted from the deck is pushed along on the traveller to the plate. In turrets the projectile is hoisted and swung by means of a davit.

The passing-box for the cartridge is made of leather with an ordinary close leather cover.

The rammer and sponge are of the old-fashioned type.

In calibres of a nature above 16-cm. a leather guard is always used in loading, to cover the gas-check and prevent injury from shocks in loading.

A system of guards against firing the gun before the breech-block is entirely closed is attached to the breech or the breech-block. In guns of the model 1864 the guard consists of a small hollow cylinder with funnel-shaped ends, acting as a sort of fairleader for the firing lanyard. On the lanyard itself are worked three turk's-heads which, when the lanyard is rove through the fairleader and hooked to the primer, come forward of the forward edge. A small spring is attached to the closing-stop of the handle, which projects into the funnel and will not permit the lanyard to pass. When the breech is closed, the crank pressing against the closing-stop pushes back the spring and allows a free passage to the lanyard. In guns of the model 1870 the guard consists of a small disc which slides over the vent when the breech-block is opened, and remains there so that a primer cannot be inserted until the block is closed *and locked*.

GERMAN ORDNANCE.

NAME, NATURE, AND CLASSIFICATION.	Calibre.	LENGTH.			Number of Grooves.	Twist of Rifling.	WEIGHT.	
		Over all.	Rifled Bore.	Powder Chamber.			Gun, including Breech-block.	Breech-block.
Krupp's pattern steel breech-loaders.								
30½ cm., hooped.....	12	264	172	54.7	72	45	78,980	2,970
28 cm., hooped and } tubed..... }	11.15	240	171	46.1	36	70	60,500	2,244
28 " hooped.....	10.34	240	171	46.1	36	70	60,500	2,244
26 " long hooped.....	10.24	225	138.5	55.3	36	50	48,400	1,980
26 " short "	10.24	205	128	42.1	36	50	39,600	1,980
24 " long "	9.27	206	136	38.4	32	70	34,100	1,375
24 " short "	9.27	185	115.4	38.4	32	65	31,900	1,375
21 " long "	8.24	185	124.6	32.7	30	68	21,450	858
21 " short "	8.24	154	96.8	31.4	30	59	19,800	858
17 " long "	6.8	167	107.5	40.8	30	45	12,320	495
17 " short "	6.8	134	92.0	24.7	30	59	11,000	484
17 " short, light } hooped..... }	6.8	136	92.7	25.7	30	45	7,590	411
15 " long hooped.....	5.87	152	105.8	27	24	45	8,800	319
15 " short "	5.87	129	86.8	23.5	24	68	7,700	319
15 " tubed.....	5.87	128	86.8	23.5	24	65	7,040	391
12 " hooped.....	4.74	115	85.7	14.7	18	60	3,014	178
8 " heavy.....	3.19	76	57.6	8.4	12	46	714	64
8 " light.....	3.19	76	57.6	8.4	12	46	650	64
8 "	2.20	62	45.9	7.7	12	46	500	55
4 "	1.54	69	54.7	9	12	70	156	9

GERMAN ORDNANCE—(CONTINUED.)

NAME, NATURE, AND CLASSIFICATION.	Preponderance.	CARRIAGES.			PROJECTILES.				
		Carriage.	Slide.	Height of Axis of Bore above Deck.	Full Weight.		Bursting Charge.		
					Chilled.	Common.	Chilled.	Common.	
	Lbs.	Lbs.	Lbs.	In.	Lbs.	Lbs.	Lbs.	Lbs.	
Krupp's pattern steel Breech-loaders.	30½ cm., hooped.....	51,040	102	715	609.5	8	22	
	28 cm., hooped and tubed....	24,200	102	561	477	7.7	25.3	
	28 " hooped.....	24,200	102	561	477	7.7	25.3	
	26 " long hooped.....	16,500	18,075	67	411	367	5.28	17.27	
	26 " short ".....	8,349	13,831	48	411	367	5.28	17.27	
	24 " long ".....	8,349	13,831	48	308	261	3.19	15.4	
	24 " short ".....	5,082	8,756	39	308	261	3.19	15.4	
	21 " long ".....	4,290	6,556	40	216	175	2.75	10.45	
	21 " short ".....	4,114	6,402	42	216	175	2.75	10.45	
	17 " long ".....	2,772	4,576	41	123	112	1.21	9.24	
	17 " short ".....	2,321	3,400	33	121	99	1.21	6.6	
	17 " short, light hooped....	2,156	2,068	34	117	112	1.32	5.94	
	15 " long hooped.....	16.5	2,057	3,806	38	78	73	7.7	6.5
	15 " short ".....	48.4	1,947	2,530	34	78	61	7.7	4.4
	15 " tubed.....	62.7	1,903	2,640	35	78	61	7.7	4.4
	12 " hooped.....	22.2	1,595	2,750	47	38	33	2.48
	8 " heavy.....	15.4	1,100	33	9.56
8 " light.....	14.7	880	35	9.56	
8 ".....	14	246	246	35	6.76	
4 ".....	Turn table.	12528	

GERMAN ORDNANCE—(CONTINUED.)

NAME, NATURE, AND CLASSIFICATION.	POWDER CHARGE.			Penetrating Power.	INITIAL VELOCITY.		WORKING EFFECT.	
	For Steel and Chilled Shot.	For Common Shell.	Shotting.		Chilled.	Common.	Chilled.	Common.
	Lbs.	Lbs.	Lbs.					
Krupp's pattern steel breech-loaders.								
30½ cm., hooped.....	158.4	158.4	...	16.4	1,591	1,623	12,584	11,176
28 cm., hooped and tubed..	132	132	14.4	1,515	1,640	8,960	8,931
28 " hooped.	132	132	13.3	1,515	1,640	7,210	8,931
26 " long hooped.....	107.8	107.8	17.6	13	1,587	1,640	6,802	6,876
26 " short "	107.8	107.8	17.6	11.5	1,490	1,387	4,835	6,466
24 " long "	59.4	44	17.6	11.27	1,502	1,391	4,625	3,511
24 " short "	59.4	44	17.6	10.05	1,469	1,355	4,625	3,327
21 " long "	41.8	30.8	13.2	8.9	1,476	1,394	3,275	2,348
21 " short "	35.2	26.4	13.2	8.55	1,312	1,394	2,587	1,970
17 " long "	26.4	22	6.6	7.25	1,548	1,525	1,944	1,809
17 " short "	17.6	14.3	6.6	7.33	1,279	1,279	1,399	1,127
17 " short, light hooped.	16.5	16.5	6.6	7.88	1,325	1,341	1,437	1,411
15 " long hooped.....	18.7	15.4	4.4	6.7	1,623	1,615	1,431	1,172
15 " short "	13.2	12.1	4.4	6.58	1,477	1,591	1,030	1,079
15 " tubed	13.2	12.1	4.4	5.6	1,358	1,446	1,001	888
12 " hooped.....	7.7	4.62	2.31	5.6	1,476	1,230	584	345
8 " heavy	1.1	1.1	1,118	84
8 " light.....	1.1	1.1	1,118	84
8 "98	1.1	1,135	66.5
4 "41	1,837

GERMAN ORDNANCE—(CONTINUED.)

GUNS.

Smooth-bore guns are now entirely obsolete. The rifled ordnance is constructed entirely on the Krupp system of steel breech-loaders. Although the Krupp system taken as a whole is represented by three distinct types of guns corresponding to different developments of the breech-closing mechanism, but one, the latest development, appears in the armament of war vessels. There are also two types corresponding to the building of the body of the guns, but these are quite similar, the difference being simply in the use of a number of thin hoops in the later guns to replace a few thick hoops in the earlier construction. All guns except the 9-pdr. bronze breech-loader are built entirely of steel. The broadside-guns of medium cali-

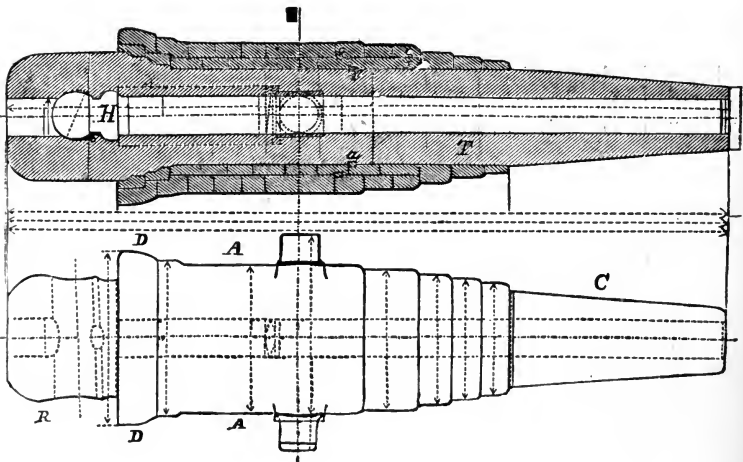

bre are divided into two classes, the long and the short gun, the latter being intended for vessels whose beam or displacement will not permit the use of the longer and heavier gun. The short gun of one calibre is, however, in all cases a more powerful gun than the long one of the next lower calibre.

All naval guns except the converted 15-cm. calibre have a steel body strengthened by hoops. The converted gun has no hoops, it having been strengthened by boring the body up to form a casing, which was shrunk over a steel tube. This tube

extends from the breech-block to about one calibre beyond the muzzle.

The 30½-cm. gun has three tiers of hoops, the 26-cm. and 24-cm. guns have two tiers, and the remainder one tier. The trunnions in all cases are in one with one of the hoops. The hoops are prolonged forward of the trunnions, diminishing rapidly in thickness.

The bore is rifled on the multigroove plan, the rifling differing slightly according to the projectile which the gun was

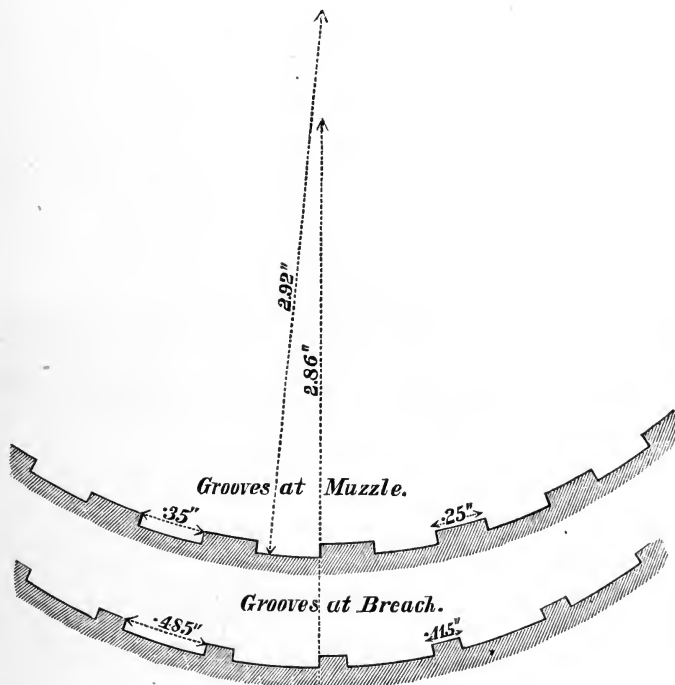

intended to fire. Formerly all projectiles were provided with a zinc rifling-jacket, and for such, a smooth shot-chamber was necessary, the rifling stopping at its forward end. The French style of copper bands being now used, the rifling is continued through the shot-chamber to the opening of the powder-chamber. With the zinc jackets, the grooves decreased in width from the breech towards the muzzle in order to keep a firm grip on the easily yielding metal throughout the bore. With the copper rotating belt the grooves are of the same width throughout.

The powder-chamber is cylindrical, and about the depth of a groove wider than the diameter of the bore across the grooves. It is connected with the shot-chamber by a short cone which brings up the rear rifling-belt of the projectile in loading. In general the powder-chamber is concentric, but there are two calibres (26 cm. and 15 cm.) in which it is eccentric, its axis being slightly above that of the bore. The powder-chamber ends in a gas-check seat, which is coned and slightly countersunk forward to receive the Broadwell gas-check.

Just behind the gas-check seat is the transverse breech-block seat, three of its sides being flat, and the rear or bearing side being hollowed out to a semicircular wall.

The bore of the gun is continued straight through the breech, forming a loading-hole in rear of the breech-block.

The breech-blocks of all guns traverse the breech transversely, and they are all single blocks. There are two patterns, differing only in the shape of the rear portion, one being

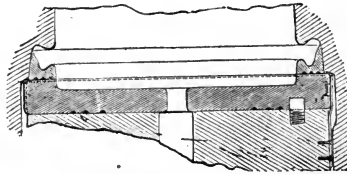

Broadwell Gas-Check, Seat, and Face-Plate.

cylindrical and the other flat. The latter type is found only in guns where formerly a double wedge (the Kreiner system) was used, so that in changing to the single wedge there was not metal enough left in rear to permit hollowing out that face.

The breech mechanism consists of the breech-block, the covering-plate, the transporting-screw, the locking-screw, the curb-chain, the gas-check, the face-plate, and the vent.

The breech-block is a heavy solid steel block, generally cylindro-prismatic, sometimes square in section. The rear of this block is not parallel to the front, but inclined in wedge shape at an angle of $1^{\circ} 55'$. The prismatic part of the block is slightly wider than the diameter of the cylindrical part, forming at the junction an edge at the top and bottom, which serves as a guide for the block in sliding in and out. The block is much shorter than the width of its seat, so that it is not necessary to entirely withdraw it in order to unmask the

bore. Except for special guns, the breech-block always draws out to the left, and its left end has bolted to it a steel plate of the same size, called the covering-plate.

This plate merely serves as a holder for the locking and moving mechanism. With light breech-blocks a shackle-handle bolts to the centre of this plate for withdrawing the block. With the heavier calibre, where the block cannot be moved by hand it is worked in and out by a screw.

This transporting-screw lies along the top of the block from end to end, revolving in journals; one half of the circumference only lies in the block, the other half, projecting, takes in a half-female thread in the upper wall of the gun. The end of the screw projecting beyond the covering-plate is squared so as to permit a crank to be shipped. In this manner, by revolving the screw, the block is worked out or in.

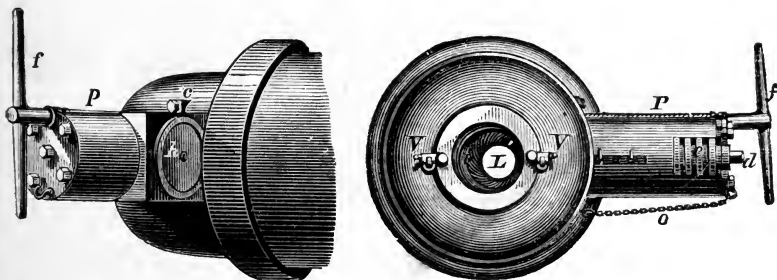

Breech-Block (front).

Breech-Block (rear).

The locking-screw, as its name implies, serves to lock the block. It is on the rear part of the block, placed like the transporting-screw only half in the block, so that its thread will take in the gun-wall. Besides locking the breech, it forces the block close home and releases it, taking the strain from the transporting-screw, which might otherwise be bent by the shock of firing. The threads of the locking-screw, except the first or outer turn, are cut away for one third of the circumference, so that the action of locking and unlocking is similar to that of the French mechanism. The outer thread is left full to cover the joint when the breech is closed. A stop on this thread limits the revolution of this screw by catching on the covering-plate, so that when brought up at one point it shows the breech to be locked, and at the other that it is unlocked. The same crank is used to work the transporting-screw and the locking-screw.

The curb-chain is a short chain which limits the withdrawal of the block and prevents it from being pulled all the way out. One end is fast to the lower end of the covering-plate, and the other to the gun just underneath.

The Broadwell gas-check is a steel ring, fixed in the gun semi-permanently; that is, it does not move with the breech-block, although it may easily be knocked out. This ring is coned around its outer edge, which is turned up cup-shaped. The inner side of this cup-rim is shaped in gutter form, in order to make the best distribution of the gas pressure. The whole middle is cut away, of the same size as the powder-chamber, so that the charge can be passed through it. Three concentric scores are cut around the back of the check, the idea being to break the force of any gas that may escape by making it suddenly expand and contract as it forces its way by them. The rear of the gas-check projects slightly beyond the rear of its seat.

The face-plate is a steel disc attached to the forward face of the block, and forming the bearing surface for the gas-check. This plate has a slightly greater diameter than the

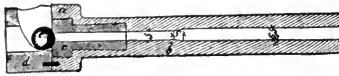

Vent-Bush and Vent Gas-Check.

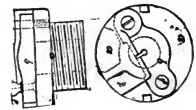

Vent-Piece, showing Hook for Head of Primer.

height of the block. It fits into a seat cut for it, and is prevented from turning or falling out by a little dowel and a spring-catch on the upper part of the block. As this plate wears, thin washers of brass or copper are fitted behind it. The rear face of this plate is fitted with grooves, which, from the shock of firing, attach and hold fast these washers. Each gun is provided with a spare face-plate and gas-check, and aboard ship a reserve gas-check is supplied in addition for each pair of guns.

The vent is pierced in a steel vent-bush, which traverses the breech-block in the axis of the bore. The forward part of the vent is provided with a simple arrangement for preventing the escape of gas. A small vertical chamber contains a steel ball, which in its normal position covers the vent completely. When the primer is fired, the flame drives the ball up and passes on to the cartridge, but the back-flame also striking the ball drives it down over the mouth of the vent again and seals it. The rear end of the vent-bush is provided with a hook for

holding the primer in place for firing. The hook itself completely covers the mouth of the vent, having a slit for the friction-bar of the primer. It is so shaped on the rear side that the back-flame through the vent throws it back. A small knob is fixed to it for convenience in hooking and unhooking. This hook is so screwed on the end of the vent-bush that it may be easily removed, and after removing the vent-bush itself may be easily backed out of the block. Aboard ship each gun is provided with two reserve vent-bushes.

The vent of the 8-cm boat-gun is a right-angled one, pierced from the face of the block to its centre, and then, turning at right angles, passes up through the block and the wall of the gun. The joint at the top of the block is made tight by copper bearing surfaces. This vent has neither the ball for checking back-fire nor the primer-hook.

All guns except boat-guns are provided with a loading-box. This is a hollow steel cylinder fitting in the loading-hole. When in place, its forward end rests against the back of the gas-check, while the rear end comes to the end of the cascabel, being provided with steadying hooks that hook into the cascabel. The charge being entered in this loading-box is pushed directly home. The boat-guns have no loading-box, but instead the right end of the breech-block is prolonged and a loading-hole is cut through it.

The transporting-screw removes the block by about one and three quarter turns, as it has a very sharp pitch. Below the calibre of seventeen centimetres there is no transporting-screw, the locking-screw serving both purposes.

CARRIAGES.

Broadside-Carriage for the Heavy and Light 8-cm. Guns.

This carriage is of the simplest construction. It consists of two plate-iron brackets connected and braced by through-bolts. It is mounted on two trucks forward, and a single broad wooden rear chock. For the light gun, breeching-holes are made in the forward part of the carriage, the ends of the breeching shackling to bolts in the ship's side; for the heavy gun, the ends of the breeching shackle to the brackets, the light being shackled under the centre of the port. These carriages are provided with breast-pieces for training, a training handspike, and tackles for running out and in. The light

gun is provided with the ordinary elevating-screw, but the heavy one has a rack, pinion, and hand-wheel for rapid and

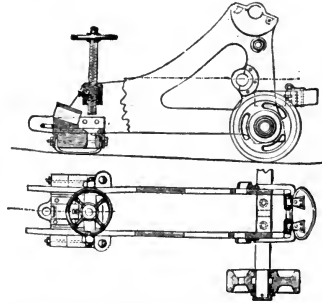

Broadside-Carriage for 8-cm. Boat-Gun.

extreme elevating. The pinion is held by a compressing lever. The trucks are of cast-iron with brass journals.

Broadside-Carriage for 12-cm. and 15-cm. Guns.

This carriage consists of two plate-iron brackets, a forward transom, and two bottom plates. The trunnion-holes, as in all other carriages, are broadened by brass journal-plates. It rests on two cast-iron trucks forward, and in rear on a rear chock. A swivel roller is fixed in the middle of this chock with a forked attachment, by which a trail handspike may be shipped at an angle of about 45° . Heaving down on this handspike lifts the rear of the carriage on the roller, and the lateral movement permitted to the handspike enables the carriage to be steered out. Bolted to the forward transom is a fork which, projecting forwards, forms a pivoting point. In running out it is necessary to run the end of this fork (which has jaws for the purpose) against the bolt provided for it to pivot about. The rear chock is of plate-iron with a brass shoe.

The recoil is governed by what is called the Brookwell apparatus. This consists of a drum with a friction-band controlled by a lever at the left side. Turns of a breeching are wrapped around the drum, the ends being fast to it, and the bight shackling to the pivot-bolt in the centre of the port. In running out, cranks slip on the ends of the axle, and the breeching is in this manner wound on the drum by heaving down the brake, the friction-band is tightened on the periphery of the drum, thus easing the recoil. The power of the cranks is not sufficient to enable the gun to be run out by this arrange-

ment, and side tackles have to be used. A reserve breeching is also kept rove, through breeching-holes in the forward part of the brackets.

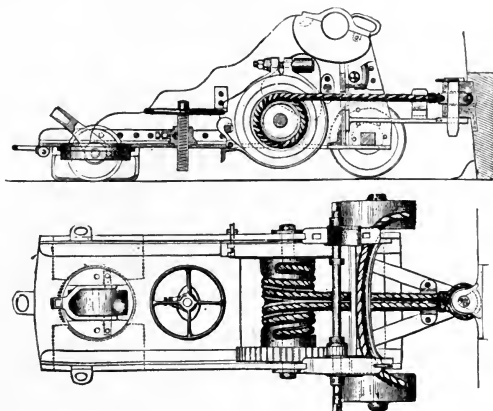

Brookwell Broadside-Carriage.

The ordinary elevating-screw is used, working in a screw-box through the rear transom.

Slide-Carriages.

Slide-carriages are used with all guns of seventeen centimetres and upwards. These carriages are classified as either carriages with fixed or with movable slides; and each of these is subdivided into slides for firing from ports or over the rail. As the necessities have arisen for modifications, changes have been made in the details of these carriages and slides, although the general form has remained the same. As a rule, the pivot centre of the slides is either in the middle of the gun-port or close to the spirketing, always forward of the body of the slide.

Slide and Carriage for Short 24-cm. and 21-cm. Guns, Pattern 1868.

The carriage-brackets are of the double-plate pattern, having a wrought-iron frame, and, connected by a bottom plate, forward and rear transoms secured by angle-irons. The carriage rests on rollers, both front and rear being on eccentric axles. The rear rollers are thrown into action by means of levers, and the act of lifting the rear of the carriage on the

axle throws the front rollers into action. The bottoms of the brackets are shod with brass friction-plates for travelling on the slide. The elevating-gear consists of a metal rack and pinion. The front edge of the rack is kept against the pinion by a smooth roller against the rear edge. The pinion is worked by means of a lever and capstan-head outside of the

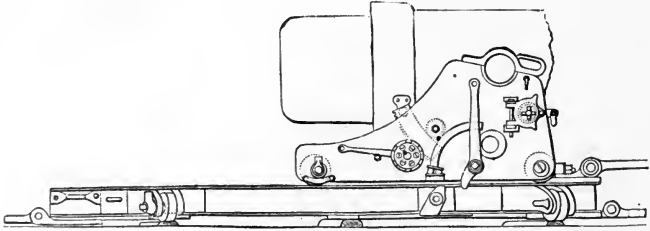

Carriage and Slide for 21-cm. Gun.

bracket. A screw-brake holds the gear fast, it being worked by a lever. When this lever is thrown up the brake is off, when down it is set fast. The carriage is run out and in by means of tackles, but one tackle being used on each side. The carriage-block for this tackle is a double block working on a hinge midway on the forward end of the bracket. The compressing arrangement is the Elswick pattern (see English Ordnance) of iron bars and plates worked by rocking levers, and having a compressing lever outside of one bracket and a regulating lever outside of the other, the former being provided with a trip for automatic compression. The carriage has also front and rear holding-down clips bolted to the bottom plate.

The slide consists of two heavy double T-iron rails bent in



Slide Tackle-Block.

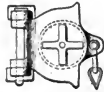

Hinged Carriage Tackle-Block.

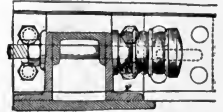

Buffer.

front. They are connected by three bottom plates, and an angle-iron joining the front ends. Seven compressor-bars are laid in the centre of the slide, and from the middle to the rear bottom plate a wooden platform is laid. Two railway buffers are provided at either end for taking up the shock in violent running in or out. The fighting pivot-flap is a stout bar hinged to the front end of the slide so as to have vertical motion; a

single eye in the end enters the jaws of the pivot-shackle in the centre of the port. The slide rests on front and rear rollers, the front ones being permanently in action and the rear



Centre Pivot-Bolt.

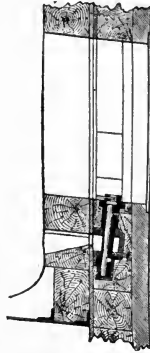

Centre-port Pivot-Bolt.

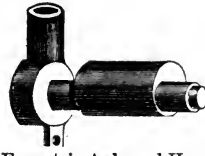

Eccentric Axle and Hand-spike Socket.

ones, on eccentric axles, being thrown into action by levers. The 24-cm.-gun slide is provided with a windlass for running in and out and training. This consists on each side of the

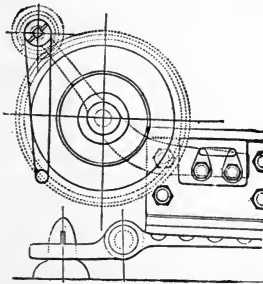

Windlass for Training and In Tackles.

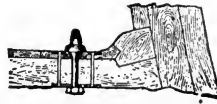

Front Housing-Bolt.

slide of a pinion turned by crank and gearing in a spur-wheel which carries the bollard. The out and in tackles are carried directly to the windlass. For training, the fall of the tackle is rove through a leading-block hooked just forward of the windlass to give a fair lead. Housing pivot-flaps are hinged at each end of the slide, which drop and key over bolts projecting from the deck. Bow and stern pivot-slides are provided with transporting rollers, which ship just inside the traversing rollers and work on eccentric axles. There are three traversing circles on the deck: the front and rear are for the front and rear rollers, the centre one holds the slide when it buckles from the position of the gun on it.

*Carriage and Slide for the Long 21-cm. Gun, Pattern
1869.*

This pattern only differs from the former in being heavier braced. The fighting pivot-flap is not hinged, but is three-armed and secures to the slide by shackle-bolts. Shifting-slides are provided with a third pair of rollers just forward of the centre of the slide, which are thrown in action when pivoting around the rear pivot-bolt; from their position, they lift the forward rollers clear of the deck when in action.

Cabin-Carriage for the Long 21-cm. Gun.

Owing to the cramped space for training bow and stern guns, and the necessity for rapid training, geared train-wheels

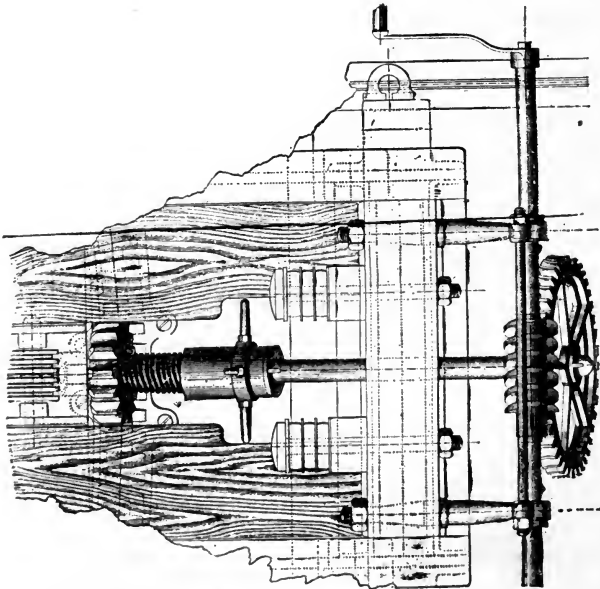

Training-Gear for Cabin-Carriage.

are used in this slide in place of the regular training-tackle. A sunken rack in the deck, midway of the slide, forms the track for a heave mitre-wheel, the axle of which cants up to the rear and is held by a journal in the rear transom. On its

outer end a large spur-wheel gears in an endless screw which is revolved by cranks. The axle of this endless screw also carries the windlass-drum for aiding the in and out tackle; it is therefore necessary that the screw and spur-wheel can un-gear. For this purpose the main axle is in two parts, the rear one carrying a heavy sleeve which is free to revolve, and has a female screw-thread worked in it and handles outside for turning. A male screw-thread is worked on the forward axle, and the end is also slotted to allow a tenon on the after axle to fit it. By revolving the sleeve, then, the rear axle is pushed to the rear through the rear journal, thus releasing the spur-wheel from the screw. In this carriage there is also a slight modification of the arrangement for jamming the elevating-gear. There is also but one compressor-lever working as a ratchet-lever in a ratchet-wheel on the compressor-axle. The slide-rollers of this type are on concentric axles in action permanently.

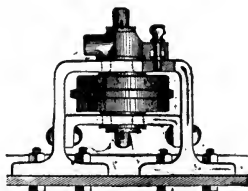

Slide Rear Roller, showing Manner of Pinning the Roller in Action.

Slide-Carriage for the Long 21-cm. Gun, Pattern 1873.

This pattern differs from the 1868 one in having a higher slide and lower carriage, gearing for training the gun, and the Scott endless chain for running out and in. The forward

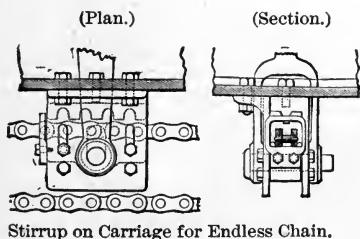

Stirrup on Carriage for Endless Chain.

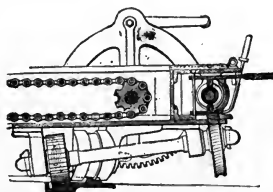

Rear of Slide, showing Training-Gear, Chain-Roller, Crank, and Recessed Rear Roller for taking Recoil.

rollers work automatically as in the former pattern. The levers for the rear rollers slip inside the brackets, and heave down instead of up for putting in action. The chain-clamp consists of a stirrup moving vertically, which carries the chain freely when down, but when hove up by a lever jams the links in a toothed rack. A stop on the outside of the brackets holds the stirrup when lifted by the lever. An endless chain

travels on each side, but only one is used, the other one being kept as a reserve. The slide-rollers are constantly in action, and are arranged to divide with the pivot-bolt the strain of the recoil. To accomplish this the circle, or racer, is made quite narrow, and the middle part of the roller is hollowed out so as to grip both sides of it. The training-gear is similar to the one

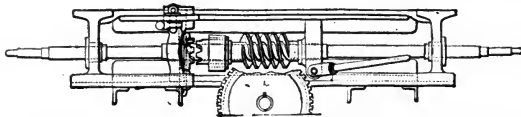

Axle-Grip for Putting Training-Gear in and out of Action.

for the cabin-carriage, except with regard to connecting the screw and spur-wheel. The screw is worked on a loose sleeve, which at its left end is toothed. A movable toothed gripe revolving with the axle, but free to move along it, is brought

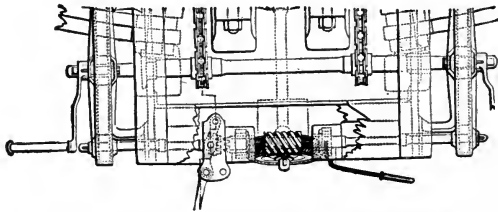

Training-Axle and Rear Chain-Axle with Gearing.

to the sleeve or retracted from it, as desired, thus revolving the screw or leaving it free on the axle. The gripe is moved by a lever. The screw-shaft is revolved by means of pinions at each end, which gear in large spur-wheels. The axle of these

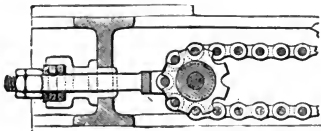

Front Chain-Roller.

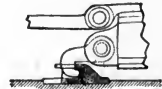

Recoil-Hook and Counter-sunk Traverse.

spur-wheels carries, also, inside the slide, the rear rollers of the endless chain. Outside of the spur-wheels are the cranks. By this arrangement, the same gearing runs the carriage in or out and trains the slide. If the gripe be backed clear of the screw-sleeve, the training-gear is thrown out of action, and by

heaving up the stirrup the carriage is clamped to the chain and run in or out. Reversing these processes, the carriage is thrown out of action and the slide is trained to the right or left.

Slide-Carriage for the Short 26-cm. Gun, Pattern 1875.

This pattern is similar in general to the one just described. The forward carriage-rollers are automatic eccentric ones, the

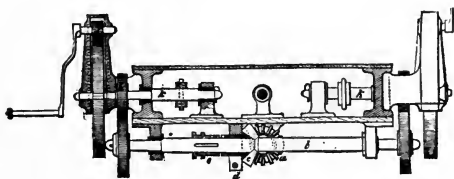

Gearing for Short 24-cm. Slide.

rear work by levers, the Scott chain-gear is used for running in and out, and similar training-gear is used. The pivot-bolt does not bear any of the shock of the recoil, it being taken up partially by the slide-rollers and partially by a cramp fixed to the forward end of the slide and travelling in an undercut circle on the deck. The slide inclines to the rear to facilitate running out.

The main difference between this carriage and the others is the use of a hydraulic recoil cylinder working in a manner

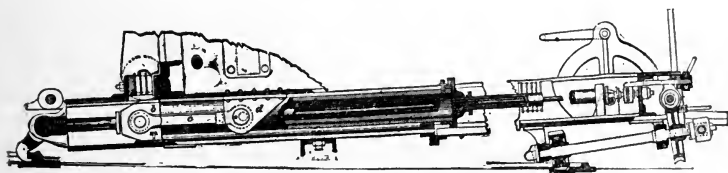

Hydraulic Recoil Cylinder and Piston.

quite different from the English style. The cylinder itself is of steel, and is hung on trunnions *to the carriage*. The piston-rod runs completely through it, and is secured at each end of the slide. Both ends of the cylinder are closed by cast-iron heads with stuffing-glands. The forward head, being the one which receives the violence of the recoil, is secured by a heavy iron brace which fastens to the cylinder trunnions. The cylinder is filled with glycerine, the filling and drip holes being both at the rear end. It rests and slides on a bed fixed along

the middle of the slide. The arrangement for checking recoil, and also for governing violent movements of the carriage, is contained in the piston-head. This head is made up of two discs which are bolted together, the interior face of each being hollowed out so as to form a chamber in the piston-head. Four holes are bored through each disc into the chamber, but they are not in line, the hole in one disc coming opposite a blank in the other. Four small valves close the inner ends of the forward holes, and these valves are secured to a plate which is free to move back and forth in the little chamber, and thus open or close the holes. A rod from the back of this plate passes through the hollow rear end of the piston-rod, and seats against a carriage-spring on the rear transom of the slide. This spring holds the valves forward, closing the forward piston-holes. A small hand-lever on the valve-rod enables it to be drawn back, thus opening the valves at will. The action of the compressor is as follows: The recoil of the gun carries

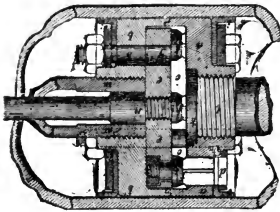

Piston-Head.

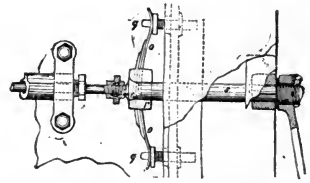

Rear End of Piston-Rod and Connections.

the cylinder to the rear and violently contracts the space forward of the piston-head; the oil is forced with violence through the forward holes, pressing back the small valves and escaping by the other holes to the rear of the cylinder. As the recoil ceases, the force of the spring carries the valve-stem and its valves forward again, closing the holes. The gun is held thus in position, as it cannot run out unless the valves permit the oil to pass into the forward end of the cylinder again. The pressure, however, comes against the back of the valves and keeps them closed. A slight turn of the hand-lever opens the valves, and the oil gaining free passage permits the gun to run out. The moment that the gun starts, however, to run out violently, a single movement closes the valves and the gun is held fast.

Slide-Carriage for the Short 24-cm. Gun, Pattern 1876.

This carriage differs in no important point from the last mentioned, except in the training-gear, which is more com-

pactly arranged. The training-shaft carries on its rear end, instead of a large spur-wheel, a small mitre-wheel. Instead of the endless screw on the shaft, there is a mitre-pinion worked on a loose sleeve and having the same locking apparatus as the one before mentioned. The outer gearing for revolving the train-work is similar to what has been described; the axle carrying the endless-chain rollers, however, is not continued across the slide, but each wheel is independent, its axle seating in a journal inside the slide.

Slide-Carriage for 17-cm., 15-cm., and 12-cm. Guns.

These carriages are of the ordinary pattern and simple in detail. The carriage-rollers are like the others, automatic forward and worked by levers in rear. The elevating-gear is rack and pinion style for the 17-cm., and simple screw for the others. In the carriages previous to 1875, breechings are used. Where the gun is not a shifting one, the bight is rove through holes in the forward ends of the brackets; where it is shifting, the ends of the breeching shackle to the brackets. The forward slide-rollers are permanently in action, the rear ones are worked by levers. Where the slide is a shifting one, a third-pair of eccentric rollers is midway of the slide and canted for rear-pivoting. The carriage is held on the slide by front and rear clips. Carriages later than 1875, unless they are of the newest type, have Elswick compressors; the latest have the before-mentioned hydraulic recoil cylinder in some instances, and in others the English style. These slides all have rear housing-bolts as above described. Where the fighting pivot-arm is long, a front housing-bolt and lip are used; if it is short, there is none. Tackles are used entirely for running in and out.

Half-Slide Carriage for the 17-cm. Gun, Pattern 1875.

(Side View.)

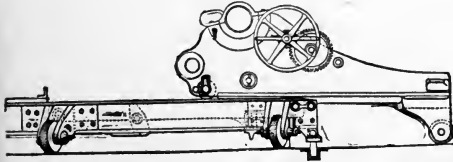

(End View.)

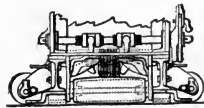

Half-Slide Carriage for 17-cm. Gun.

The general plan of slide and carriage is similar to the foregoing. The slide is, however, very low and short, its roll-

ers being permanently in action. The carriage has two front rollers on eccentric axles worked by levers. The rear of the carriage is somewhat longer than ordinary, and under it is hung a single long roller, which, when the gun is run out, does not touch the deck. In recoiling it drops to the deck and supports the rear of the carriage. The recoil is checked by the Elswick compressor, and in addition a breeching is provided, whose bight runs through holes in the front of the bracket. Rack and pinion elevating-gear is used. In slides intended for shifting ports, the rollers can be turned around a vertical axis and be locked so as to move the slide sideways.

Slide-Carriages for Light Guns Firing over the Rail.

The only difference between these and the others is that the slide is much higher and is centre-pivoting. In order to take off the shock of recoil from the pivot-bolt, the slide-rollers overlap the circles on both sides.

Slide-Carriage for the 30½-cm. Gun for Armored Gun-boats.

The general principle of the carriage is the same as the ordinary one. Its front and rear rollers are the same, and the elevating-gear is the rack and pinion type, the power being increased in accordance with the greater weight to be moved. The carriage is heavier braced, having three transoms in place of two. There are no out-tackles or chain-gearing, the slope of the slide (6°) being sufficient to run the gun out by its own weight. When it is necessary to run it in, in-tackles are used, the falls being taken over windlass-heads on the rear hurter of the slide. The slide is centre-pivoting, and traverses on four heavy rollers which overlap the edges of the circles to take the force of the recoil. A cramp under the forward end of the slide moving in an undercut circle on deck also takes the recoil shock. The gun is traversed by gearing. Just inside the roller-circles is a circular rack into which a pinion gears; the inner end of the pinion-axle carries a mitre-wheel whose upper and lower cogs gear in mitre-pinions which are worked on loose sleeves on a vertical axle. Between these pinions, revolving with the axle, but free to move vertically, is an iron grip which catches in the upper or lower pinion, according as it is desired to sweep the gun to the right or left. The vertical axle passes down to the lower deck, where is a train-work with crank-handles to be revolved by six men. By means of the simple grip arrangement between the mitre-pinions, the gun may be traversed to the right or left or stopped

without reversing the motion of the crank-handles below. The hydraulic recoil cylinder above described is used to check the recoil and control the running out of the gun. A sheet-iron musket-proof shelter is raised on the slide for the protection of the gun's crew. For lifting the projectile to the gun a derrick is fixed at the rear of the slide. The fall of the

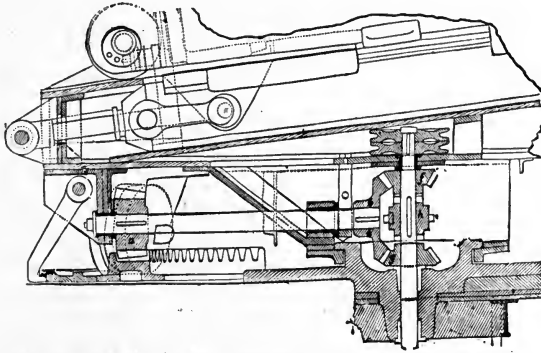

Front Half of Slide for Centre-Pivoting Gun-boat Carriage.

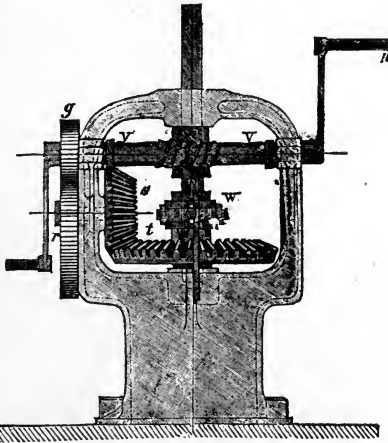

Gear below Deck for Revolving Gun-boat Carriage.

whip is taken around a windlass-head, and the davit is swung around by means of an endless screw and pinion.

Turret-Carriage for the 21-cm. Gun (Arminius).

The turret-slide is fixed, and forms a part of the turret. The rails incline forward at an angle of 6° , so that out-tackles

are unnecessary. The carriage-rollers are of the ordinary type. But one lever is used in throwing the rear trucks in action, as

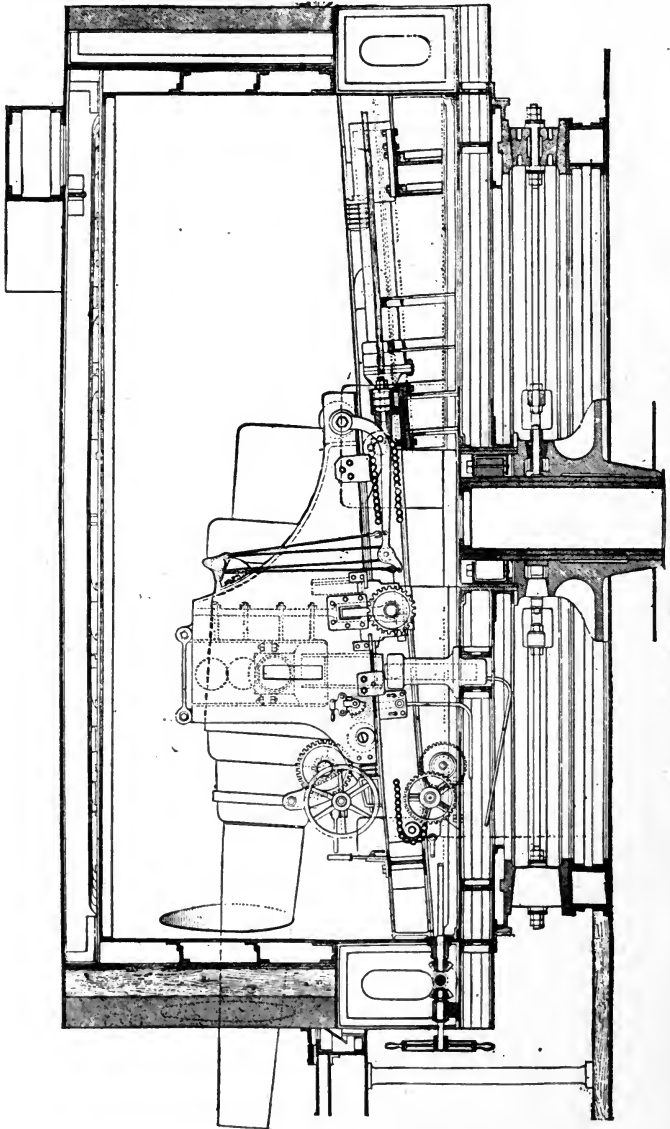

Turret Carriage for Minimum Port. (See next page.)

there is not room to work on the inside of the carriage. For running in, two chains shackle to the turret in rear of the gun

and pass over a drum in the centre of the carriage. The drum is revolved by gearing. The recoil is controlled by the Elswick compressor. The elevating-gear is the single-screw type.

Turret-Carriage for the 24-cm. Gun, Pattern 1874.

This carriage, intended for a small port, differs in height and shape from the previous ones in order to permit a vertical elevation and depression of the gun-trunnions. It is built on the double-plate plan, with heavy transoms and bottom plates. The four carriage-rollers are arranged in the usual manner, the levers for throwing the rear trucks in action being moved by a tackle. The elevating-gear is fixed to the chase of the gun forward of the trunnions. It is of the ordinary rack and pinion type, but does not connect with the carriage, being hung in a frame which projects from the trunnions. The gun is run in and out by means of the endless-chain gear, the gearing being connected to a long shaft outside of the turret, to which three hand-wheels are attached. These hand-wheels are of course underneath the upper deck, coming out directly under the port. The recoil is governed by a hydraulic recoil piston, the arrangement in this case being identical with the English system. (See English Ordnance.) The trunnions have three positions, the lower, middle, and upper. They are supported in a saddle whose arms travel in a framework in the brackets, being supported by iron blocks inserted through holes in the sides of the brackets. The saddle is raised by a hydraulic press, which is so fixed in the turret that the piston takes against the bottom of the saddle when the gun is run out. The details of this arrangement are precisely similar to those of the corresponding English turret-carriage. The slide-rails are fixed in the turret with a slope to the front of 5° . In addition to the chain nipping-gear and the hydraulic recoil piston, the gun-carriage is provided with bow-compressors on each side. (See English Ordnance.)

Boat-Carriages.

The boat-carriage complete consists of a wooden slide bound together in front and rear by iron plates, and a composite carriage made up of a wooden bed surmounted by an iron bed-plate and bracket-frames for the trunnions. Two buffers are put at the rear of the slide to take an over-recoil. The elevating-gear is the simple screw and hand-wheel. The compressor is a brass-faced block whose upper side takes in undercut spaces in the slide. The block is held up and tightened

by a screw and hand-clamp. For transporting the boat-carriage and gun together a small block-cart is used, which is

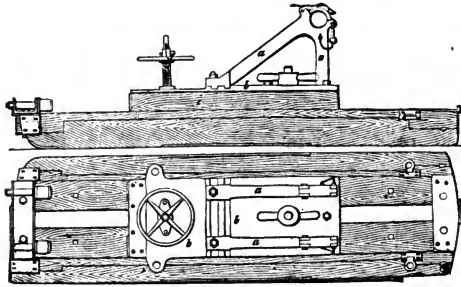

Boat-Carriage.

nothing more than a heavy, flat, wooden body provided with an axle and two gun-trucks.

Field-Carriages.

The field-carriage is of the ordinary type, consisting of two straight iron brackets, strengthened along the upper edge by angle-irons, and curved to form a sole at the bottom. To this a trunnion socket-frame is bolted. The brackets are braced by transoms and by two side rods. An iron axle bolts to the under side of the brackets just in rear of the trunnion-holes.

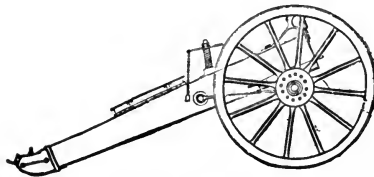

Field-Carriage.

The wheels are wooden with brass hub-boxes and iron tires. The elevating-gear is of the plain screw and hand-wheel pattern. A limber is provided with this carriage which carries two ammunition-boxes, each of which holds six rounds of shell and the corresponding cartridges (not fixed to the projectile). The carriage itself also carries two ammunition-boxes of the same size.

GUNPOWDER.

The gunpowder used for the majority of naval guns is of the kind known as prismatic powder. Of this there are two classes. The first, for use with the heaviest calibres, is solid; that for medium calibres is pierced with holes longitudinally—for the high calibres with one central hole, and for the medium with seven. Large-grained cannon-powder is used in shell-guns, whilst the usual classes of small-grained powder is used with small-arms and for shell-charges. Prismatic powder is invariably used for battering-charges in all calibres, the gradation with regard to time of burning being obtained by the holes pierced through the grains: slow powder, solid; medium, one hole; quick, seven holes.

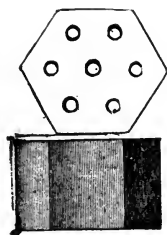

PROJECTILES.

The projectiles used in the German Navy are shot, shell, case-shot, and shrapnel. Shot are either solid or hollow for the lighter calibres, and hollow for the heavy ones. They are of ordinary cast-iron, chilled cast-iron, and steel, the solid shot being invariably made of ordinary cast-iron. They are of two

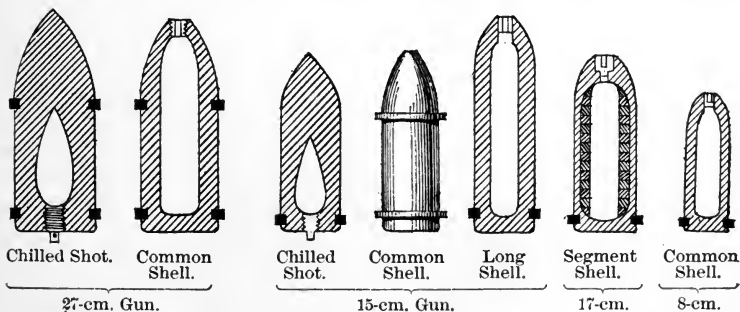

different types, according to the style of rifling arrangement. In the earlier patterns, all projectiles were provided with a lead belt extending from the shoulder to within about two inches of the base. To receive and hold this jacket, broad shallow grooves were cut around the circumference of the projectile, the ridges left having slots cut through them at intervals to resist the tendency of the jacket to slew around. The jacket was

moulded around the projectile and zinc-soldered. Corresponding with the grooves in the projectile, there were grooves in the jacket to receive the overflow of metal forced back when the projectile took the rifling.

In the late patterns, instead of a jacket, two rings are used; the forward one being for centring or holding steady the head of the projectile, and the rear and larger one for rifling. This rear one is provided with grooves to receive the overflow of metal. Both rings are copper. The steel and chilled shot are very similar in appearance.

Shell are similar in exterior shape and appointment to shot, and are all made of ordinary cast-iron. Double shell (see English Ordnance) are used with the 17-cm. and 15-cm. calibres.

Case-shot are of the ordinary pattern.

Shrapnel are only used with boat-guns, and are similar in construction to the English. (See English Ordnance.)

Solid shot are used only with the 17-cm. and 15-cm. guns.

Case-shot are not used with boat-guns.

Hollow-shot, shell, and case-shot are used with all the higher calibres.

Fuses are not used with hollow-shot, the bases of which are closed by a gun-metal screw-plug.

FUSES.

Both percussion and time fuses are used in the shells of all calibres. The percussion-fuse consists of a plunger having a fire-hole through the centre and surmounted by a pointed anvil. This is dropped into the fuse-hole of the shell, and hangs on a shoulder in the wall of the fuse-hole. Even with the point of the anvil a hole is bored through the wall of the shell



German Percussion-Fuse.

horizontally, into which a pin is inserted whose inner end covers the anvil and keeps it from going forward. A gun-metal case screws into the end of the fuze-hole, and into this screws a small cap carrying the fulminating composition. When the gun is fired the centrifugal force throws the pin out, and when the projectile strikes the plunger rides forward

against the fulminate and explodes it. The fulminate-cap and the pin are not inserted until the projectile is brought to the gun, the mouth of the fuse-hole being kept sealed by a wafer. The Krupp time-fuse consists of a gun-metal body which



German Time-Fuse.

screws into the fuse-hole and has two chambers. The lower one, containing the blowing-charge, opens into the shell. It is solid to the rear, except a diagonal channel on one side which is pierced up and opens on a small table which carries the fuse-composition disc. The latter is circular and on the principle of the Bormann fuse, its exterior wall being marked for seconds and fractions. The upper chamber of the fuse is open at its upper extremity and closed at the lower, except several side channels leading to the composition-disc. In the bottom of this chamber is a pointed anvil. The fuse-cap is ogival and screws over the upper chamber, fitting tightly down on the composition disc. In this cap is a plunger loaded with fulminating composition at its lower end, and suspended by five small tenons. The composition is ignited by the percussion part of the fuse on firing. A safety-pin passes through the fuse-cap and plunger, and is withdrawn when the shell is brought to the gun.

PRIMERS.

Friction primers are used altogether. These are of the same type as those used with English guns. (See English Ordnance.)

SIGHTS.

The sights used with naval guns are all of the tangent pattern, and all except the boat-guns are provided with sights on both sides. The socket for the tangent-sight is bored through the breech-piece, the upper part having steel or bronze bushing and a clamp-screw passing through at right angles. The sight is cylindrical, with a flat rear surface on which is marked elevations to sixteenths of degrees. On the left cylindrical side, elevations for every 100 metres are marked for com-

mon shell, and on the right for chilled or steel shot. The head of the sight consists of a rectangular cross-head fastened to the

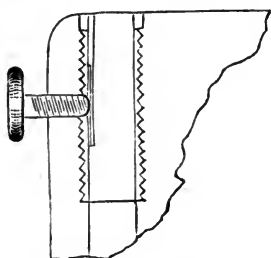

Sight-Bush and Clamp

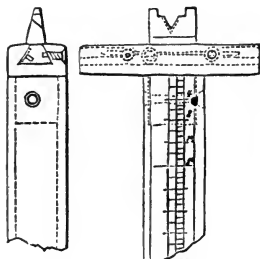

Rear-Sight.



Front-Sight.

top of the bar, in whose upper surface a swallow-tailed groove is cut in which travels the sight-notch. On the face of the cross-head, gradations of sixteenths of a degree corresponding to elevations are marked, and the sight-notch carries a small pointer. The gradations are marked each way so as to account

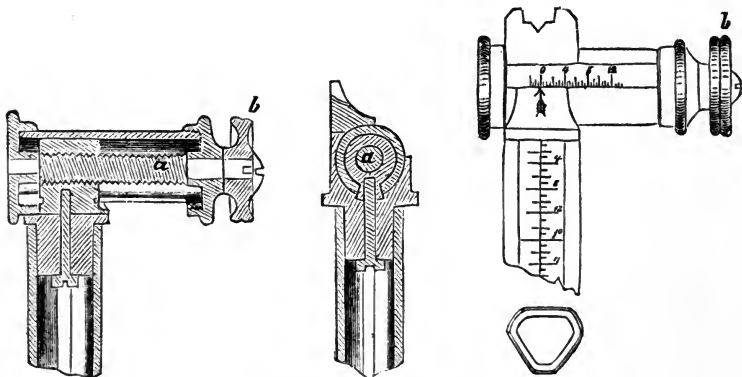

Rear-Sight for Light Guns.

for drift and deviation to the right or left. The forward sight is cylindrical, with a conical point, and screws into the trunnion-hoop. Sights for boat-guns differ in having gradations only on the rear face, and the sliding leaf works by an endless screw. These sights are all vertical. With some boat-guns, however, the tangent-sight is placed at a permanent angle of deflection, in which case there is no sliding leaf.

ITALIAN ORDNANCE.

NAME, NATURE, AND CLASSIFICATION.	LENGTH.				Number of Grooves.	WEIGHT.			
	Calibre.	Over all.	Rifled Bore.	Powder Chamber.		Twist of Rifling.	Gun entire, including Breech-block.		
							Lbs.	Lbs.	
	In.	In.	In.	In.		Calib.	Lbs.	Lbs.	
Armstrong pattern Muzzle-loaders.	43 cm.....	17	392	311.3	52	27	$\frac{0}{35}$	222,300	9,980
	28 " New Model....	11	173	120.5	24.4	9	$\frac{0}{35}$	55,800
	28 " Old "	11	173	119	26	8	$\frac{0}{35}$	55,800
	25 " No. 1 Long....	10.1	173.2	119.1	26	7	$\frac{0}{36}$	40,100
	25 " " Short ..	10.1	167.6	113.9	26	7	$\frac{0}{36}$	40,400
	25 " No. 2.....	10.1	156.1	111.1	14	8	55	27,000	630
	22 "	9	156.1	105.6	19.7	6	$\frac{0}{35}$	28,260
20 "	8	130	88.6	15.8	6	45	15,680	805	
Cast-iron Muzzle-loaders.	16 " Wrought-iron } Tube..... }	6.5	142.1	104	13.8	6	42.5	11,440	1,065
	16 "	6.5	126.7	94.1	13.9	6	42.5	7,920	924
Armstrong Breech-loader.	12 "	4.7	70.4	19.7	27	2,640	50.4
Bronze Breech-loader.	7.5 "	2.95	70.1	52.4	10.2	12	48.6	596	79.2
Bronze Muzzle-loaders.	8 "	3.4	45.3	9.8	6	25	726
	8 "	3.4	31.9	3.5	6	25	240
Cast-iron Muzzle-loader.	12 "	4.77	73.3	6.3	6	27	2,948

ITALIAN ORDNANCE—(CONTINUED.)

NAME, NATURE, AND CLASSIFICATION.	Weight of Carriages	Height of Axis of Trunnions above Deck-level.	PROJECTILES.					POWDER CHARGE.				
			Weight Complete.			Bursting Charge.		Chilled.	Common.	Ordinary.	Sighting.	
			Steel.	Chilled.	Common.	Chilled.	Common.					
	Lbs.	In.	Lbs.	Lbs.	Lbs.	Lbs.	Lbs.	Lbs.	Lbs.	Lbs.	Lbs.	
Armstrong pattern Muzzle-loaders.	43 cm.....	2,000	37	..	471	
	28 " New Model....	17,820	52	528	528	200	5.7	26	95	95	66	..
	28 " Old "	17,820	52	528	530	200	5.7	26	95	95	66	..
	25 " No. 1 Long ...	15,750	44	294	300	188	5	24	77	77	53	..
	25 " " Short ...	15,590	46	294	300	188	5	24	77	77	53	..
	25 " No. 2.....	12,620	42	288	284	135	3.3	18	64	64	42	..
	22 "	12,620	42	248	252	99	2.2	19	60	60	37	..
20 "	7,480	34	156	150	79	1.3	9.7	44	44	24	..	
Cast-iron Muzzle-loaders.	16 " Wrought-iron Tube.....	4,540	46	65	33	..	2.3	20	20	7	8
				66	33	..	3.3	7.7	..	8
Armstrong Breech-loader.	12 "	35	2.6	5.5	..	2.2
Bronze Breech-loader.	7.5 "	477.4	8	9	..	.5	1.5	..	1.4
Bronze Muzzle-loaders.	8 "	587.4	9	9.25	..	.7	1.2	..	1.2
	8 "	176	9	4.4	..	.77	..	1
Cast-iron Muzzle-loader.	12 "	550	26	22.6	..	3.1	3.3	..	2.2

ITALIAN ORDNANCE—(CONTINUED)

NAME, NATURE, AND CLASSIFICATION.	INITIAL VELOCITY.		WORKING EFFECT.		Penetration.	REMARKS.
	Chilled.	Common.	Chilled.	Common.		
	Ft.	Ft.	Ft. Tons.	Ft. Tons.	In.	
Armstrong pattern Muzzle-loaders.	43 cm.....	1,584	34,550	22.8
	28 " New Model...	1,312	1,312	6,300	6,300	12.1
	28 " Old " ...	1,312	1,312	6,262	6,330	12.1
	25 " No. 1 Long....	1,410	1,399	5,369	5,390	11.7
	25 " " Short....	1,410	1,399	5,369	5,390	11.7
	25 " No. 2.....	1,410	1,420	3,952	3,970	10
	22 "	1,476	1,476	3,731	3,790	10.3
	20 "	1,476	1,509	2,345	2,345	8.7
Cast-iron Muzzle-loaders.	16 " Wrought-iron } Tube..... }	1,525	1,066
	16 "	1,026	483
Armstrong Breech-loader.	12 "	1,368	457
Bronze Breech-loader.	7.5 "	1,312	97.5
Bronze Muzzle-loaders.	8 "	1,040	63.4
	8 "	764	33.8
Cast-iron Muzzle-loader.	12 "	1,095	12

ITALIAN ORDNANCE—(CONTINUED.)

The standard Italian naval ordnance is the Armstrong muzzle-loader. There are some batteries of breech-loaders of the French type, and now that the Armstrong 100-ton gun has become a part of the standard ordnance, the government have ordered them made breech-loading with the Armstrong breech mechanism. The guns are to be provided with arrangements for both breech and muzzle loading. With the breech-loading, as the block is turned to unlock it, a grip on the end of a hydraulic piston in rear takes in a slot in the block, and when the latter is unlocked, a movement of the piston to the rear withdraws it from the gun to a small car having a transverse motion by which the block is carried sideways so as to unmask the bore. An iron cylinder is then inserted and pushed up to the rear of the powder-chamber as a loading-plate, guarding the screw-threads from injury. The charge, being raised by a hydraulic press in the usual manner, is forced home by a hydraulic rammer, and the breech-block is closed by its car and piston. The Gatling gun is used, and there has been an attempt to introduce the Albertini machine-gun, which is used in the army. Although of native manufacture, it has not as yet been received with much favor, being still too complicated in its mechanism, although the instrument is not as yet perfected.

GREEK ORDNANCE.

The armament of the Greek Navy is exclusively of Armstrong muzzle-loaders.

DUTCH ORDNANCE.

The standard naval ordnance of Holland is at present the Krupp type. Many of their vessels have batteries of Armstrong muzzle-loaders, and there are a few Finspong guns. The Hotchkiss machine-gun has been adopted for torpedo defence. (See page 305.)

JAPANESE ORDNANCE.

The standard Japanese naval ordnance is the Krupp. There are a few batteries of Armstrong muzzle-loaders, but none are now purchased.

SWEDISH ORDNANCE.

NAME, NATURE, AND CLASSIFICATION.	Calibre.	LENGTH.			Number of Grooves.	Twist of Rifling.	WEIGHT.		
		Over all.	Rifled Bore.	Powder Chamber			Gunn complete, including Breech-block.	Breech-block.	
									In.
Rifled Breech-loaders, cast-iron with steel hoops.	27 cm.....	10.8	210	162	30 3	5	29 2	52,088	770
	24 ".....	9.4	179	133	26.6	5	29.3	31,800	528
	16 ".....	6.6	135	89.5	16.8	5	29.8	12,000	170
Cast-iron Muzzle-loader, Rifle.	12 ".....	4.6	102	97	13 6	4	40	4,200
	15 in.....	15	146	43,000
Cast-iron Smooth-bore.	9 ".....	9	158	38,000

NORWEGIAN ORDNANCE.

Armstrong Muzzle-loaders.	27 cm.....	10.5	162	110.6	30.5	8	55	40,500
	27 ".....	10.5	176	120	25	8	55	43,400
	27 ".....	10.5	206	47,700
	20 ".....	8	130	85.7	18.8	6	50	16,700
Fallsler Muzzle-loaders.	16 ".....	6.6	139	85.7	18.5	3	34.1	11,000
	15 ".....	6.1	123	93.2	10.8	3	34.1	7,700
Krupp Breech-loaders.	26 ".....	10.2	225	160.5	34	60	45	48,400	1,960
	15 ".....	5.9	152	112	22.6	36	45	8,800	304

SWEDISH ORDNANCE—(CONTINUED.)

NAME, NATURE, AND CLASSIFICATION.	Preponderance.	CARRIAGE.			PROJECTILES.				
		Upper Carriage.	Slide.	Height of Axis of Gun above Deck-level.	Complete Weight.		Bursting Charge.		
					Chilled.	Common.	Chilled.	Common.	
	Lbs.	Lbs.	Lbs.	In.	Lbs.	Lbs.	Lbs.	Lbs.	
Rifled Breech- loaders, cast- iron, with steel hoops.	27 cm.....	127	23,076	23,076	49	475	396	23.2
	24 ".....	220	5,370	45	317	220	9.3
	16 ".....	403	2,105	2,200	40	107	76.5	3.7
Cast-iron muzzle- loaders, cast- iron, Rifle.	12 ".....	85	2,105	900	41	34	2.2
	15 in.....	253	31	430	340	14
Cast-iron Smooth- bore.	9 ".....	53	31	150	112	5.8

NORWEGIAN ORDNANCE—(CONTINUED.)

Armstrong Muzzle- loaders.	27 cm.....	1,340	6,720	28	385	308	6	21
	27 ".....	440	7,600	8,000	38	385	308	6	21
	27 ".....	403
	20 ".....	761	7,000	7,000	39	149	149	1.76	10.1
Palliser Muzzle- loaders.	16 ".....	246	1,880	2,150	43	82.5	3.3
	15 ".....	246	1,000	2,300	43	58	3
Krupp Muzzle- loaders.	26 ".....	756	20,608	20,608	52	462	380	59.4	21
	15 ".....	160	5,600	5,600	41	86	70	1.1	5

SWEDISH ORDNANCE—(CONTINUED.)

NAME, NATURE, AND CLASSIFICATION.	POWDER CHARGE.		INITIAL VELOCITY.		WORKING EFFECT.		Penetration.	REMARKS.	
	Chilled.	Common.	Chilled.	Common.	Chilled.	Common.			
	Lbs.	Lbs.	Feet.	Feet.	F't Tons.	F't Tons.			
Rifled Breech-loaders, cast-iron with steel hoops.	27 cm.....	98	66	1,364	6,153	12	} Finspong Rifles.
	24 ".....	59.4	37.4	1,322	1,476	3,763	3,333	10	
	16 ".....	23.3	17.6	1,377	1,591	1,414	1,347	7.36	
Cast-iron Muzzle-loader, Rifle.	12 ".....	6.5	4.4	1,456	509	
	Cast-iron Smooth-bore.	15 in.....	50.1	35	1,213	
9 ".....		24.8	17.6	

NORWEGIAN ORDNANCE—(CONTINUED.)

Armstrong Muzzle-loaders.	27 cm.....	66	38.5	1,302	1,148	4,541	3,156	10.5
	27 ".....	71.5	38.5	1,371	1,148	5,032	3,156	11
	27 ".....
	20 ".....	29.7	19.8	1,364	1,148	1,938	1,360	7.9
Palliser Muzzle-loaders.	16 ".....	22	11	1,138	742	7.1
	15 ".....	7.1	1,115	404
Krupp Breech-loaders.	26 ".....	99	81.4	1,584	1,584	7,933	6,644	14
	15 ".....	18.7	18.7	1,590	1,640	1,528	8

NORWEGIAN AND SWEDISH ORDNANCE.

The Norwegian ordnance is both smooth-bore and rifled, the smooth-bore guns being of the Rodman (see page 283) and the rifles of the Krupp style. The Swedes manufacture their own breech-loaders, having chosen for their standard the French type of cast-iron body reinforced by steel hoops. These guns, known as the Finspong breech-loaders, have proved very satisfactory, the Swedish cast-iron being second only to American in excellence. The breech-blocks and steel hoops for these guns are all made in France. Two types of machine-guns, which have found general favor in Europe, are of Swedish invention.

The Nordenfeldt Machine-Gun.

This gun, which has been experimented with in the English Navy, is intended as a defence against torpedo-boats. It has four barrels placed in line, having a calibre of one inch, to fire a half-pound steel projectile. The projectiles are placed in guides behind the rear of the barrels, and by the movement of a lever are sent into the chamber, fired, and the empty shell extracted. Gearing worked by hand-wheels gives elevation and direction. The fire is rapid from this gun, and the results have been excellent for penetration. Weight of the gun complete, about 1000 pounds.

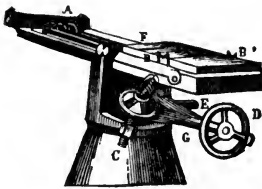
*The Palmerantz Machine-Gun.*

The Palmerantz mitrailleuse is a machine-gun for firing small-arm ammunition. It has ten barrels placed side by side and secured in a frame, the rear ends of the barrels being screwed into a single bar-transom, behind which the lock mechanism is placed in a flat rectangular box. The system is mounted on a swivel in such a manner as to give it free motion for elevating and depressing or sweeping. An eccentric cam attached to the crank-axle can be thrown into gear, by means of which the barrels are given an automatic sweep through a small arc. The whole gun is compact and light. Each barrel has a separate feeder, so that the velocity of discharge is very great, the barrels being fired in succession.

RUSSIAN ORDNANCE.

NAME, NATURE, AND CLASSIFICATION.	Calibre.	Length over all.		Number of Grooves.		Weight of Gun, including Breech-block.	Preponderance.	Weight of Upper Carriage.	PROJECTILES.			
		In.	In.	36	Cal.				Complete Weight.			
									Lbs.	Lbs.	Lbs.	Steel.
Krupp Russian pattern steel Breech-loaders.	Finished.	12 in.....	12	240.8	36	..	89,173	1,958	649	644
		11 ".....	11	219	36	70	57,280	0	10,604	495	462	439
		9 ".....	9	180	32	60	33,150	440	270	264	267
		9 ".....	9	156	32	60	29,920	748	270	264	267
		8 ".....	8	175	30	60	19,820	440	4,686	180	191	172
	Unfinished.	6 ".....	6	140	24	45	9,370	352	3,508	96	85.4	84
		8 ".....	8	175	30	60	17,570	792	4,868	180	191	182
		6 ".....	6	146	24	45	10,090	1,078	3,522	96	85.4	84
		9 pdr.....	4.2	16	..	1,738	...	693	24
		4 ".....	3.4	70	12	40	792	88	739	14
Bronze Rifled Muzzle-loaders	8 pdr.....	4	1,650	666	26	
	4 ".....	3.4	809	603	11.5	
	4 ".....	3.4	865	603	{ Cast-Round	Iron Shot. }	13.5	
American pattern cast-iron Smooth-bore Muzzle-loaders.	20 in.....	20	96,360	1,000	1,000	
	15 " new.....	15	180	72,160	0	440	440	373	
	15 " old.....	15	170	43,340	1,078	6,270	440	440	373	
	10 3/4 ".....	10.75	168	26,180	1,333	160	160	
	60 pdr. No. 1.....	7.6	135	10,780	792	2,220	57.7	57.7	43	
	60 " " 2.....	7.6	7,040	1,518	57.7	57.7	43	
	36 " " 1.....	6.8	7,040	1,518	40	40	29	
	36 " " 2.....	6.8	5,610	1,210	40	40	29	
	36 " " 3.....	6.8	4,590	990	40	40	29	
	36 " " 4.....	6.8	4,240	790	40	40	29	
	30 " " 1.....	6.4	6,864	1,408	32	32	26	
30 " " 2.....	6.4	5,214	1,188	32	32	26		
30 " " 3.....	6.4	4,330	1,528	32	32	26		
30 " " 4.....	6.4	1,770	32	32	26		

RUSSIAN ORDNANCE—(CONTINUED.)

NAME, NATURE, AND CLASSIFICATION.	PROJECTILES.			POWDER CHARGE.				INITIAL VELOC'Y.	Working Effect.	Penetration.		
	Bursting Charge.			For Steel and Chilled Shot.	Common Shells.	Ordinary.	Saluting.	Steel.				
	Steel.	Chilled.	Common.									
	Lbs.	Lbs.	Lbs.	Lbs.	Lbs.	Lbs.	Lbs.	Feet.			Ft. Tons.	In.
Krupp Russian pattern steel Breech-loaders.	Finished.	12 in	16	121	..	58.5	..	1,446	9,408	14.1
		11 "	12	7	13.5	82.5	..	41.2	9	1,205	5,844	11.6
		9 "	7	4.5	9.5	47	..	23.4	7.2	1,341	3,365	9.8
		9 "	7	4.5	9.5	43	..	23.4	7.2	1,276	3,043	9.3
		8 "	5	2	6.2	28.5	..	14.2	7.2	1,404	2,463	9.0
	Unfinished.	6 "	1.8	3	18	..	10.8	4.5	1,335	1,188	7.1
		8 "	5	2	6	22.5	..	14.2	7.2	1,246	1,938	7.8
		6 "	1.8	3	14.4	..	10.8	4.5	1,207	972	6.4
		9 pdr.	1	2.7	2.5	2.7	Common 1,049	183
		4 "5	1.5	1.5	1.5	Common 1,003	96
Bronze Rifled Muzzle-loaders.	8 pdr.	1.5	3.6	3.6	3.6	
	4 "8	1.5	1.5	1.5	Common 1,000	77	
	4 "	1	{ Cast-iron Round Shot }	2	1.8	1.8	
American pattern cast-iron Smooth-bore Muzzle-loaders.	20 in	117	1,118	8,581	
	15 " new	10.75	67.5	45	27	9	1,184	4,263	
	15 " old	10.75	67.5	45	27	9	971	2,872	
	10¾ "	36	9	
	60 pdr. No. 1	1.8	14.5	..	10	4.5	
	60 " " 2	1.8	10.8	..	2.6	4.5	
	36 " " 1	1	8	..	2	3.6	
	36 " " 2	1	8	..	2	3.6	
	36 " " 3	1	6.2	..	1.6	3.6	
	36 " " 4	1	5.5	..	1.4	3.6	
30 " " 18	9	..	2.3	2.7		
30 " " 28	6.7	..	1.7	2.7		
30 " " 38	5	..	1.2	2.7		
30 " " 48	3.5	..	.9	2.7		

RUSSIAN ORDNANCE—(CONTINUED.)

The standard type of Russian ordnance is the Krupp breech-loader, manufactured in their own workshops, and slightly modified in some few details of guns and carriages. Some of their monitors are armed with the Rodman type of 15-inch smooth-bore. During the first period of the development of rifled guns the Russians adopted the Armstrong muzzle-loader, and shortly afterward they passed to the French breech-loader, there being still several armaments of these types in the wooden fleet; but all types have been superseded by the Krupp. The circular iron-clads having their guns firing *en barbette*, are worked on depressing carriages of Russian invention.

The Razkazoff Depression-Carriage.

This carriage consists of a heavy bed-plate, at the forward end of which is a heavy solid axle forming a turning-point for two solid cast arms, the upper ends of which form seats for the trunnions. Connected to these arms are the piston-rods of hydraulic recoil cylinders. The breech of the gun is supported by auxiliary arms, the bottom rests of which are mounted on screws in such a manner that they may be traversed through short lengths, thus elevating or depressing the gun. When the gun is down in its loading position these arms may be freely traversed, and the desired elevation be thus attained before raising the gun for firing. Both the Palمرantz and the Hotchkiss machine-guns are used.

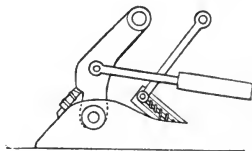

PERUVIAN ORDNANCE.

The naval ordnance of Peru consists of a few smooth-bores of the Rodman type and some Armstrong muzzle-loaders of the original type. They also have two or three Whitworth muzzle-loaders. The machine-guns are Gatlings.

PORTUGUESE ORDNANCE.

The Portuguese Navy has a few Krupp breech-loaders, but the wooden fleet is for the greater part armed with Armstrong muzzle-loaders.

SPANISH ORDNANCE.

The greater part of the Spanish fleet is armed with Armstrong muzzle-loaders, but medium-calibred steel guns of the French type are now manufactured in their own government workshops, some of which have been introduced into the navy, and it is supposed that at least for medium calibres this type will be the standard. There are some Krupp armaments, but these are exceptional. The Gatling machine-gun is used.

TURKISH ORDNANCE.

The greater part of the ordnance of the Turkish fleet is of the Armstrong muzzle-loading pattern, although there is a preference for Krupp armaments, which are used to replace the original type of Armstrong guns. The Gatling machine-gun is used.

EUROPEAN SYSTEMS.

Of the breech-loading systems of Europe there are at present but two distinct types in use—the French and the Krupp—the latter being the one at present most fully represented, it being the standard ordnance of Germany, Russia, Austria, Denmark, and Holland.

The French type is the standard of France, Spain, Sweden, and, as may now be claimed, Italy. Armstrong, whose artillery is almost as fully represented as Krupp's, has adopted the French type, and this will in all probability make this type the standard in those countries who purchase guns instead of manufacturing them.

The muzzle-loading types were abolished by all the manufacturing nations of Europe except England by 1864, although the prestige of Armstrong's ordnance has kept up the supply to the smaller nations to the present time. This ordnance has been steadily growing in disfavor, and the latest development in rifled ordnance (enlarging the powder-chamber) will probably lead to its disuse.

UNITED STATES ORDNANCE.

NAME, NATURE, AND CLASSIFICATION.	GUN.					Weight of Carriage.	Weight of Slide.	
	Length of Bore.	Calibre.	Number of Grooves.	Twist of Rifling.	Weight.			
	In.	In.		Feet.	Lbs.			Lbs.
Muzzle-loading Rifles.	8-inch converted	136	8	15	40	17 350	3,790	3,710
	100-pdr. Parrott.....	130	6.4	9	$\frac{9}{16}$	9,700	1,300	{ Directing } Bar
	60-pdr. "	105	5.3	7	$\frac{9}{16}$	5,400	1,970	"
	30-pdr. "		4.2	5	$\frac{9}{16}$	3,550	1,970	"
	20-pdr. "		3.7	5	$\frac{9}{16}$	1,750	802	"
	20-pdr. Dahlgren.....	65.6	4	3	$12\frac{1}{2}$	1,350	802	"
Breech-loading Rifles.	12-pdr. bronze.....	55	3.4	3	10	880	482	{ Boat } Carriage
	80-pdr. converted.....		6.4	9	$\frac{9}{16}$	10,166	1,300	{ Directing } Bar
	60-pdr. "		5.3	7	$\frac{9}{16}$	5,270	1,970	{ Directing } Bar
	30-pdr. "		4.2	5	$\frac{9}{16}$	3,428	1,970	"
	20-pdr. bronze, converted...		4	6	$12\frac{1}{2}$	1,340	832	{ Boat } Carriage
	20-pdr. converted.....		3.7	5	$\frac{9}{16}$	1,740	826	"
	7-pdr. bronze, heavy.....		3	16	$7\frac{1}{2}$	500	535	"
7-pdr. " light.....		3	16	$7\frac{1}{2}$	350	450	"	
Smooth-bores.				Weight of Shot.				
					Lbs.			
	15-inch.....	146	15	450		43,000	18,000	{ Turret } Carriage
	11-inch.....	131	11	166		16,000	3,790	3,710
	9-inch.....	107	9	90		9,000	1,300	Marsilly
	8-inch.....	96	8	65		6,500	860	"
	32-pdr.....	92	6.4	32.5		4,500	735	"
	24-pdr. bronze.....	58	5.8			1,310	730	"
12-pdr. " heavy.....	55	4.6	{ Shell } Guns.		760	Boat 482	Field 487	
12-pdr. " light.....	50	4.6			490	233	331	

UNITED STATES ORDNANCE—(CONTINUED.)

	NAME, NATURE, AND CLASSIFICATION.	Weight of Shell.	Charge of Powder in Shell.	Powder Charge.	Initial Velocity.	Muzzle Energy.
		Lbs.	Lbs. Ozs.	Lbs.	Feet.	Foot Tons.
Muzzle-loading Rifles.	8-inch converted.....	180	10 0	35	1,450	2,627
	100-pdr. Parrott.....	100	3 11	15	1,080	810
	60-pdr. ".....	48	2 2	6	1,320
	30-pdr. ".....	29	1 8	3 $\frac{1}{4}$
	20-pdr. ".....	18	0 13	2
	20-pdr. Dahlgren.....	18	1 0	2
Breech-loading Rifles.	12-pdr. bronze.....	12	0 8	1
	80-pdr. converted.....	80	3 11	15	1,250
	60-pdr. ".....	50	6
	30-pdr. ".....	30	3 $\frac{1}{2}$
	20-pdr. bronze, converted.....	18	0 8	2
	20-pdr. converted.....	20	2	1,070
	7-pdr. bronze, heavy.....	7	1	1,087	63
7-pdr. " light.....	7	3 $\frac{1}{4}$	1,087	63	
Smooth-bores.	15-inch.....	352	13 0	100	1,600	7,997
	11-inch.....	136	6 0	30	1,062	1,300
	9-inch.....	74	3 0	13	1,320	847
	8-inch.....	53	1 11	7
	32-pdr.....	27	0 14	6
	24-pdr. bronze.....	23	1 0	2
	12-pdr. " heavy.....	12	1 0	1
12-pdr. " light.....	12	1 0	1 $\frac{1}{2}$	

UNITED STATES ORDNANCE—(CONTINUED.)

GUNS.

In the United States Navy both smooth-bores and rifles are used, and of the latter both muzzle and breech loaders.

Smooth-Bores.

The smooth-bore guns used form a complete range of calibres from the 15-inch to the 6½-inch. The turret-guns, which are exclusively of the 15-inch pattern, are of the Rodman type of construction, of cast-iron, being cast on a core and

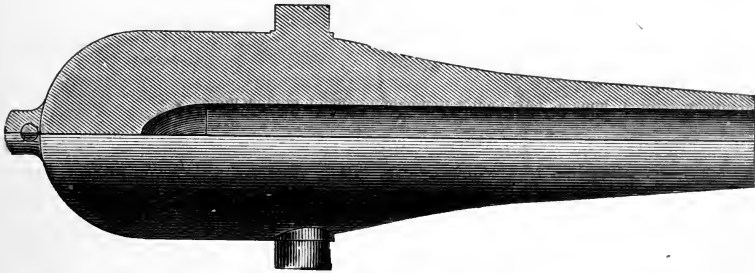

15-inch Rodman Gun (Smooth-Bore).

cooled from the interior. The exterior surface shows no sharp angles and no muzzle-ring, the general shape being that of a bottle with a rounded base. The chamber of the gun is of two types, cylindrical and conical, in accordance with different

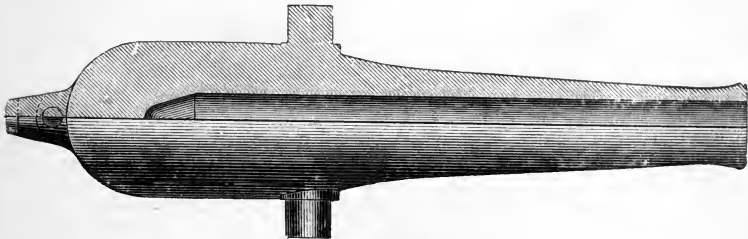

9-inch Dahlgren (Smooth-Bore).

dates of fabrication. The 11-inch guns are used exclusively for pivot-guns of first and second class corvettes, and it is this calibre that is being converted into 8-inch rifles, the intention

being to so transform all of this type. These guns are of the Dahlgren type of construction, being similar in shape to the

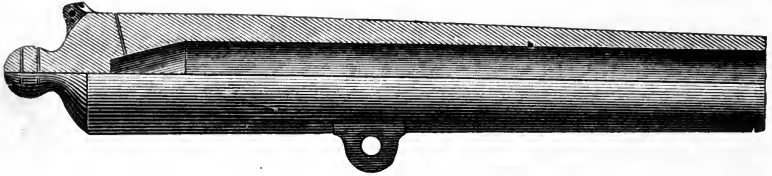

12-pdr. Bronze (Smooth-Bore).

15-inch (with the exception of having a swell at the muzzle), but *solid* cast. These guns all have conical chambers. The

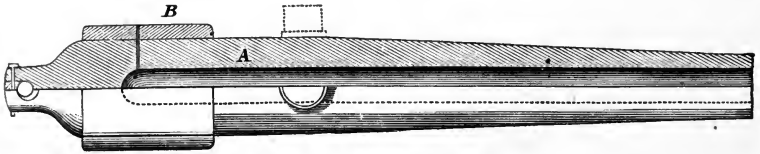

100-pdr. Parrott M. L. R.

9 and 8 inch and 32-pdr. are broadside-guns, and are similar in construction to the 11-inch. The 24-pdr. and two classes of

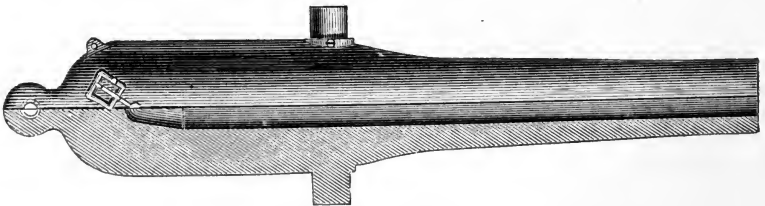

20-pdr. Bronze M. L. R.



12-pdr. Bronze M. L. R.

12-pdrs. are of bronze, having a conical exterior surface. These guns are used as light upper-deck guns and boat-guns.

Rifled Guns.

The muzzle-loading rifled guns are of three patterns.

1st. The 8-inch converted. These guns are all converted from the 11-inch smooth-bore on the Palliser system (see page 217), the length of bore being slightly increased by cutting back at the breech.

2d. The Parrott type, a compound gun consisting of a cast-iron body with a coiled wrought-iron hoop over the powder-chamber. These guns were introduced into the service in 1860, contemporaneously with the first development of rifled guns in Europe.

As early as 1862, guns of this type with a calibre of eight inches were in active service, being at that time as powerful as any guns in the world. The 8-inch calibre has never been extensively used in the service, and is at present obsolete.

3d. The Dahlgren type of bronze muzzle-loaders. The 20-pdr. gun of this type is similar in shape to the general smooth-bore type, slightly modified. The light calibres are similar to their corresponding smooth-bores.

Breech-Loaders.

The breech-loaders with the exception of the bronze and steel boat-guns are as yet entirely converted from the muzzle-loaders of the Parrott type. In this conversion, the

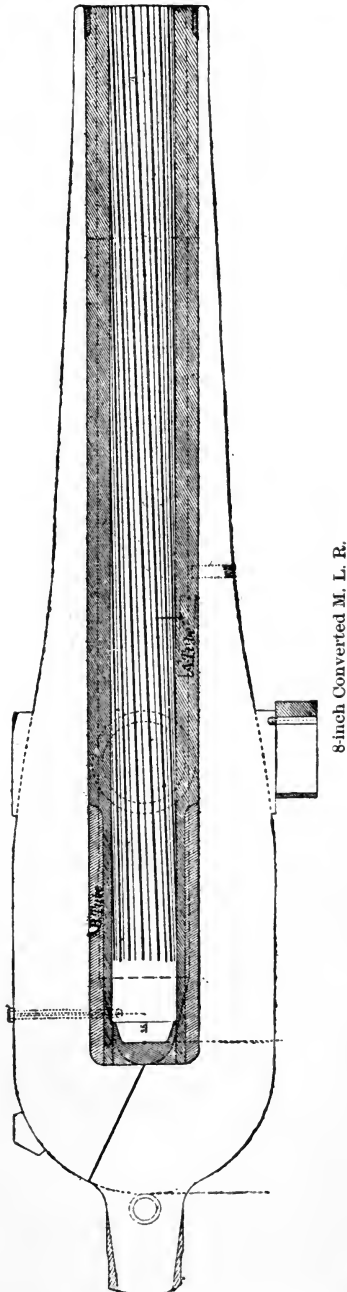

8-inch Converted M. L. R.

coiled hoop is removed, the cascabel is cut off to the powder-chamber, and the rear end of the bore as far forward as the trunnion is reamed out for the insertion of a steel tube, having

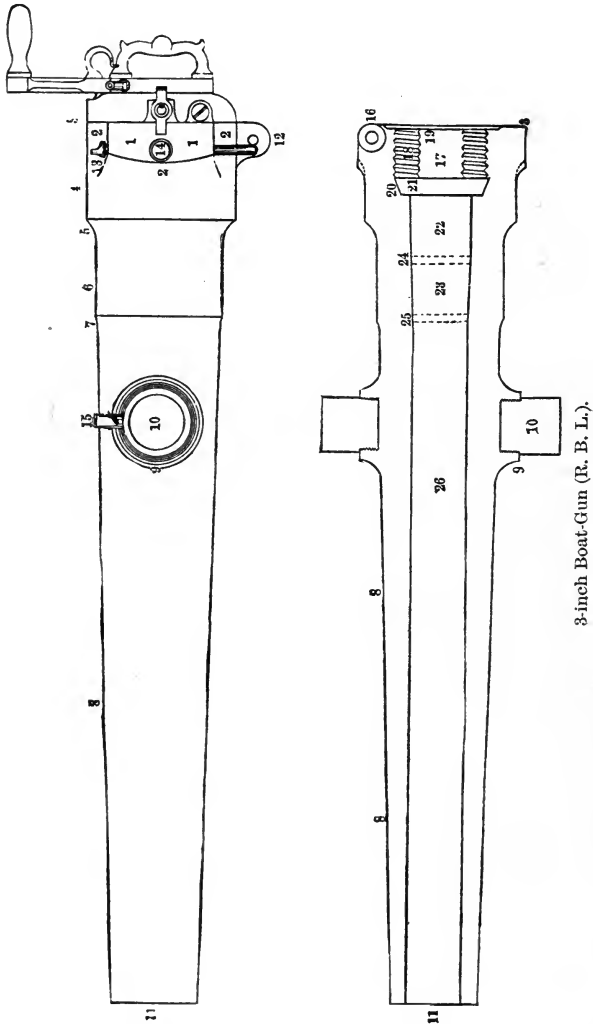

a heavy screw-thread at its rear end by which it is secured in the casing. The old rifling is then carried through this tube, leaving the calibre unchanged. The coiled hoop is replaced by another of similar type, but covering a longer space. The

breech mechanism is of the French type, with Broadwell steel gas-check fixed in its seat in the gun. The breech-block is provided with a steel nose-plate of the diameter of the face of the block, and having a copper ring countersunk in its forward face to form a bearing surface against the rear of the gas-check. The nose-plate is secured to the block by a long tenon which passes through the axis of the block and is secured by a nut at the rear. The vent is bored axially through this tenon,

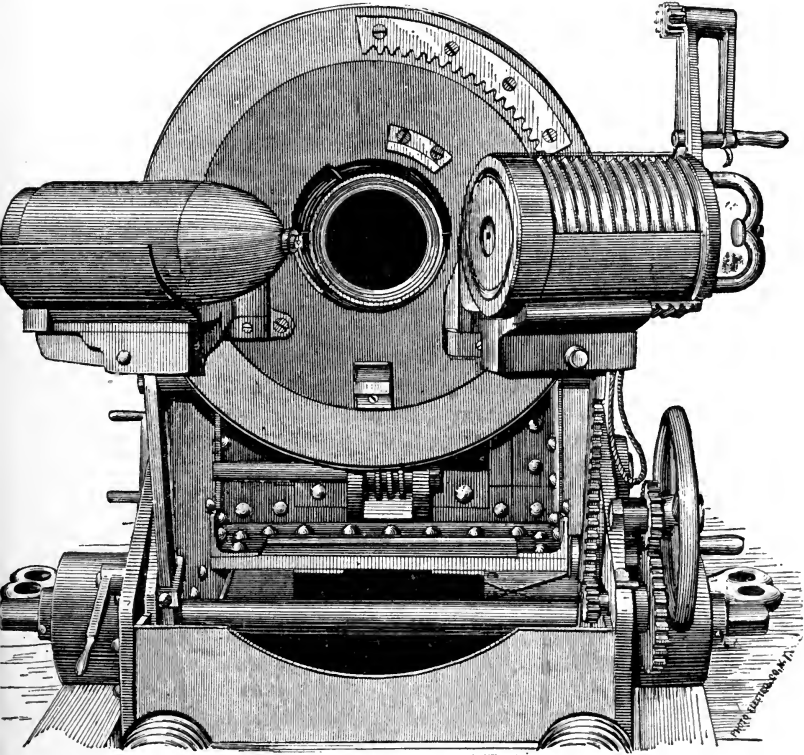

and is of two types, corresponding to date of fabrication, for preventing back-fire. In the first, a small steel plate covers the forward end of the vent, being loosely secured, so that on firing the flame escapes past the edges of the plate, but the back pressure holds the plate close over the vent; the action being precisely similar to that of an ordinary valve. In the other type, the forward part of the vent is reduced in size until just large enough to give free passage to

the flame, giving it a needle-point, which causes the flame to pierce well into the cartridge. The back pressure is neutralized in this manner, as it reacts before the forward flame pressure is relieved. It is intended to so modify the firing arrangement as to use percussion primers, the gun-lock forming the mask to the vent. The crank is double, there being a vertical arm having at its upper extremity a crank and a pinion working in a rack on the face of the breech. The swinging tray for the breech-block is hinged at the right side of the breech, while at the left side is hinged a loading-tray having a sliding guard on it. The projectile being placed on this guard and the tray swung around to face the bore, on pushing forward the projectile the guard also enters the breech-block seat, bringing up against the gas-check, and thus guarding both the check and the screw-threads. In the boat-guns there is no loading-tray, the remainder of the breech mechanism being of the same type. Boat-guns are both of steel and bronze, being in both cases made of a single block.

Grooves.

The grooves are of two types. Those for the Parrott and converted guns are of the plain rectangular type, the rule for their number and size being that they shall be uneven in number to bring a land opposite a groove; lands and grooves

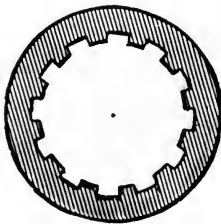

Parrott Groove.

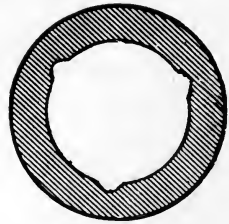

Dahlgren Groove.

shall be equal in width, and grooves for all calibres shall be the same depth— $\frac{1}{10}$ of an inch. Increasing twist. The Dahlgren type of groove is similar to the modified French groove (see plate, page 187), there being three only of a regular twist. These grooves are found only in the Dahlgren muzzle-loading bronze boat-guns.

CARRIAGES.

Naval gun-carriages are built of plate-iron, although there are still a few wooden carriages and slides for pivot-guns. Breechings are used with broadside-carriages, except in the directing-bar type.

Boat-Carriages.

As yet the designs for an iron boat-carriage for the breech-loading gun are not finished. The wooden carriage in use consists of a double wooden slide, the bed, or lower slide, having pivot-centres in front and rear and being slotted through the

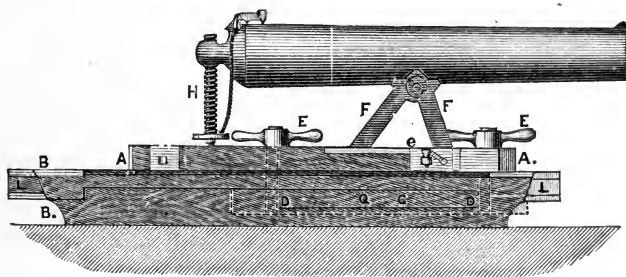

Wooden Boat-Carriage.

centre for the compressor. The upper slide traverses freely on the lower one, having a piece projecting from its lower face into the slot in the lower slide to act as a guide. A second heavy piece, used as a compressor, travels along the lower face of the slot, and is held in position by screw-handles working on threaded shafts which are tightened or loosened readily by hand. The upper slide holds the trunnion-rests, which are made in a single casting with a bottom plate to bolt on the slide.

Field-Carriages.

The field-carriages are of two types, both of iron. That for the muzzle-loader consists of a single bar to which the axle is bolted and stayed. To its lower end is bolted an iron box for a trail-wheel and a socket for a directing handspike. A small seat for the elevating-screw is bolted at its middle on top, and at the forward end is a light iron frame for holding two am-

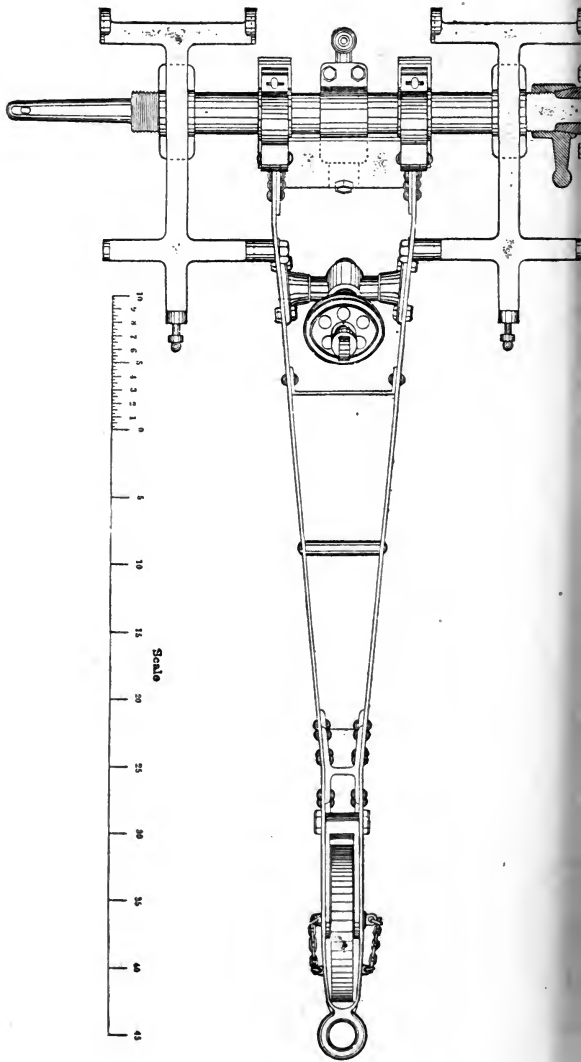

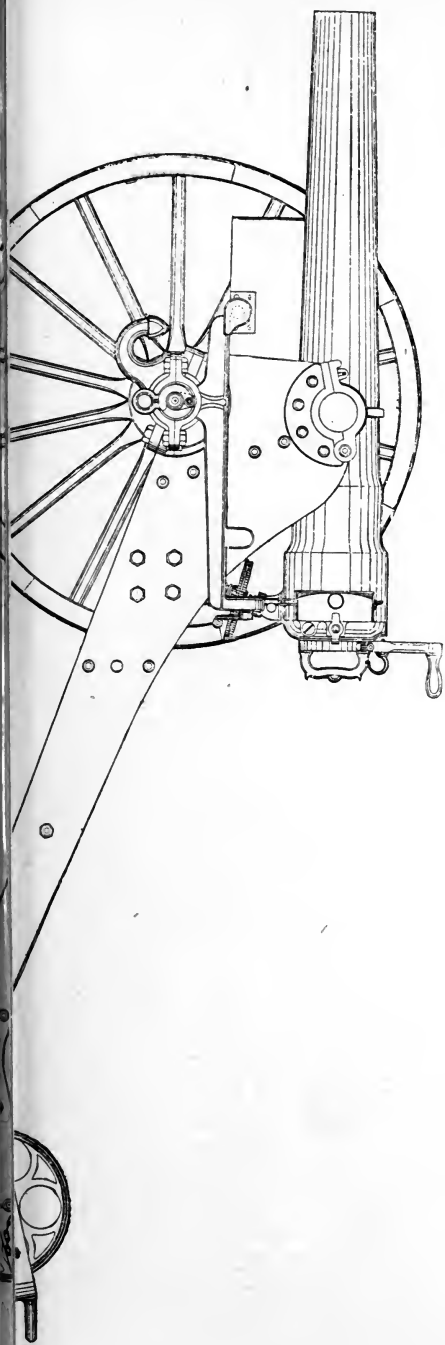

munition-boxes. The field-carriage for the breech-loader consists of two plate-iron brackets connected by the axle and three transoms. The lower part expands into a box for the trail-wheel, and the end is finished in a loop for a drag-rope. At the forward end is a lug for attaching a caisson, and a frame

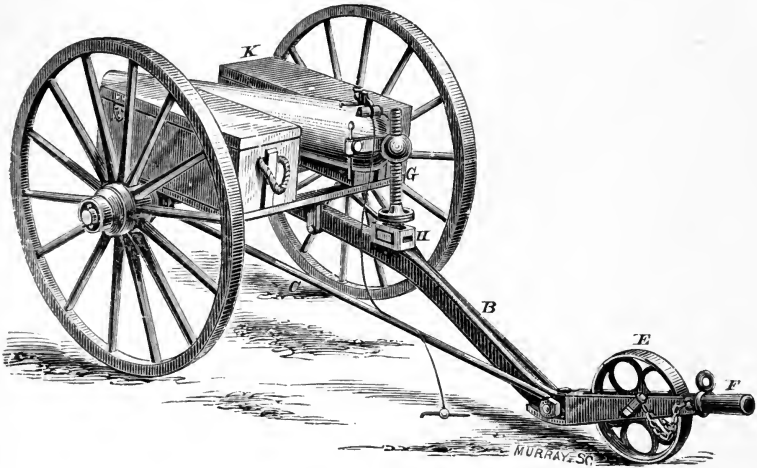

Iron Field-Carriage for Muzzle-Loaders.

on the axle outside of the brackets on each side for ammunition-boxes. The elevating-screw works in a pivoting screw-box. It will be noticed that the breech-loader has trunnions, while the muzzle-loader has only a lug, making the forward ends of the two carriages different in construction.

Broadside Marsilly Carriage.

The Marsilly or rear-chock carriage is the type used with the broadside smooth-bore guns. It consists of two plate-iron brackets with a transom across the front ends and a bed-plate in the rear, giving a support for the elevating-screw, and being provided with two brass friction-shoes resting directly on deck. Holes are cut in the brackets to lighten them. A wooden breast-sweep is bolted to the transom, and there are four bolts for hooking tackles, one at each end and one at the rear of each bracket. This carriage differs from European ones in the point of not having the breeching attached to it; the latter is secured to the gun.

Broadside Directing-Bar Carriage.

The directing-bar carriage is a broadside-carriage which combines the compactness of broadside types with the advantages of pivoting and checking recoil by friction instead of breechings. The top carriage is similar in type to the Marsilly,

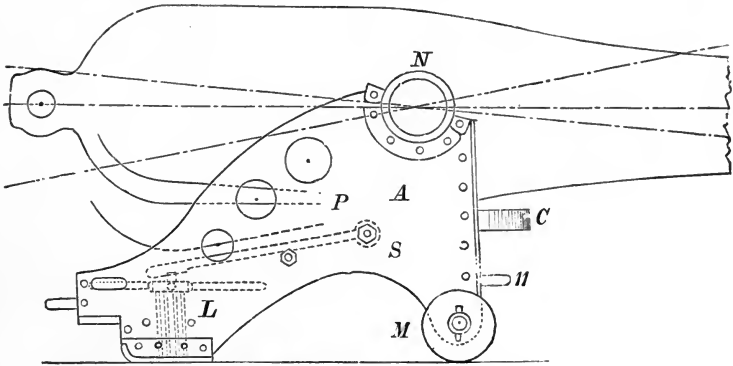

Broadside Marsilly Carriage. (Elevation.)

differing only in its attachments. Instead of using an elevating-screw (which with breech-loaders of medium calibre is unsafe), elevation is secured by geared racks. A rack is secured to each side of the gun and travels in guides in a similar

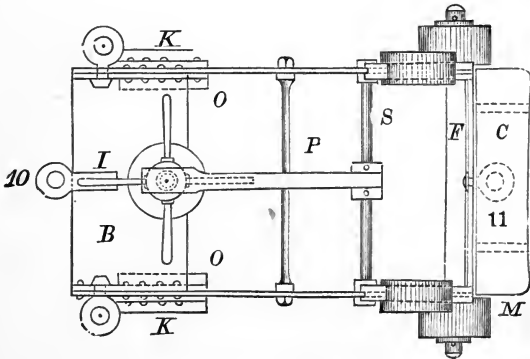

Broadside Marsilly Carriage. (Plan.)

manner on both sides ; whilst, however, there is a clamp to each rack, there is but one hand-wheel for elevating, on the right side of the carriage. Just in rear of the truck-axle, a heavy axle is secured in the brackets, carrying on its centre a large

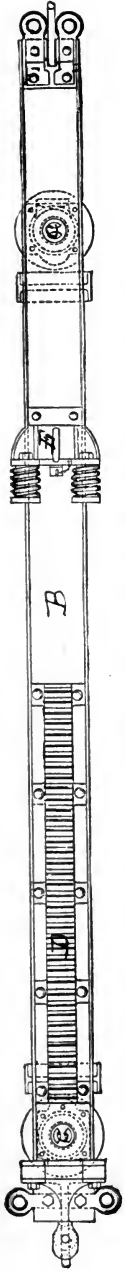

DIRECTING BAR CARRIAGE

FOR

60 Pdr.

(With Circular Brake Compressor.)

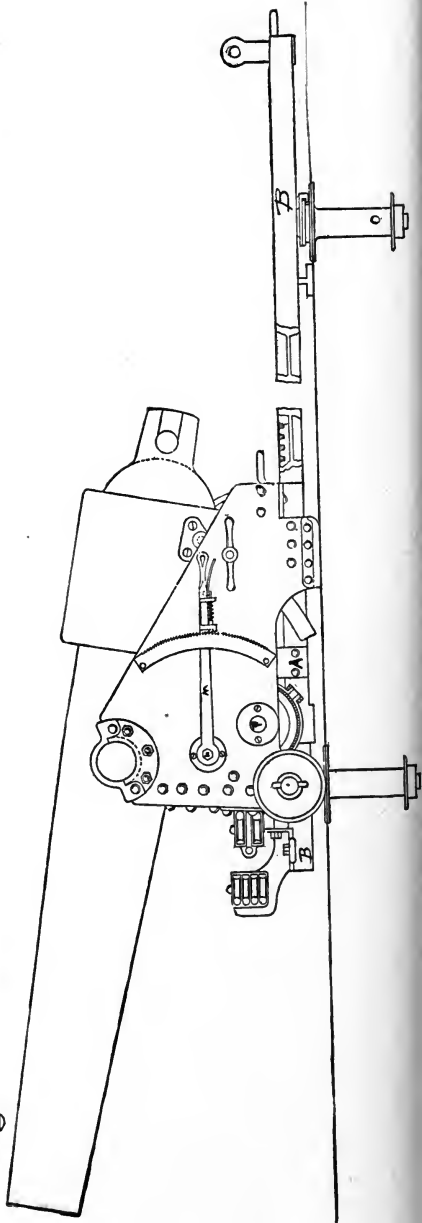
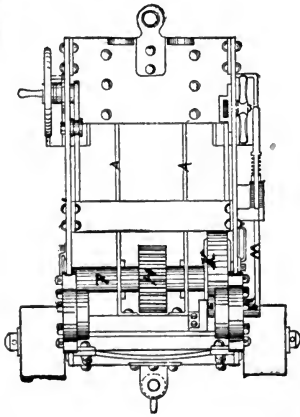
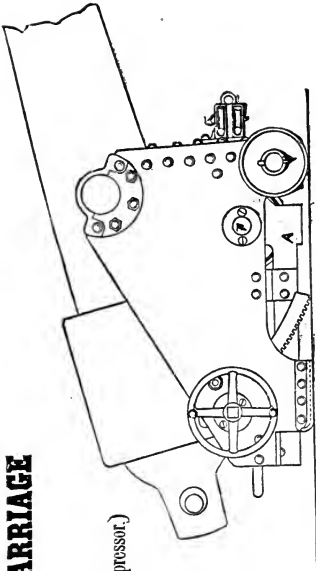

cogged wheel, and just inside the left bracket a friction-drum with a gun-metal friction-band worked by a lever outside the bracket. The lever is held in any desired position by a rack, thus regulating compression. A stationary double block is secured to the transom, and a single bolt to the rear of the bed-plate, for convenience in hooking a tackle. The directing-bar consists of a long I iron having a pivot-centre near each extremity and eye-bolts at each end for hooking training-tackles. A treble block fixed at its forward end serves with the double block on the carriage for reeving an out-tackle. Along the centre of the bar a metal rack is bolted, in which the cogged wheel of the carriage travels. About three quarters of the distance to the rear are secured two railroad buffers, which may be shifted or removed at will. The carriage rests with its trucks and chocks on deck; when running in and out the chocks may be lifted from the deck on a roller handspike, and in shifting from one port or pivot to another the carriage may be run over one of the pivot-centres and then lifted with the bar entirely clear of the deck.

Iron Pivot-Carriage and Slide for 11-inch Smooth-Bore.

The carriage consists of two plate-iron brackets with one transom and two bottom plates connected by angle-irons to the brackets. The forward trucks are permanently in action, the rear ones being mounted on eccentric axles. At the rear of the brackets are loops for the in and out tackles, and secured to the rear bed-plate are loops for a preventer-breeching. Two projecting lips protude from the forward bed-plate beyond the brackets, forming seats for a screw-compressor. The slide is made up of two heavy double T bars connected by bottom plates and rods. It is mounted on eccentric rollers, and both the forward and rear pivot-centres are in the bed-plates. The compressors (one on each side) are of the ordinary screw-press form, composed of a wrought-iron frame having a lip on its inner lower side which takes under the slide-bars, whilst a screw in the top of the frame seats on the projections of the carriage. This type of slide and carriage is going out of use.

Iron Pivot-Carriage with Central Recoil Check.

This carriage is the same in general principle as the ordinary pivot-carriage, the main modification being in the arrangement for checking recoil. A worm-shaft, attached to the transom of the carriage and worked by a hand-wheel outside the left

bracket; gears in a large cogged wheel just outside the transom. This wheel has at the lower end of its axle a screw-sleeve

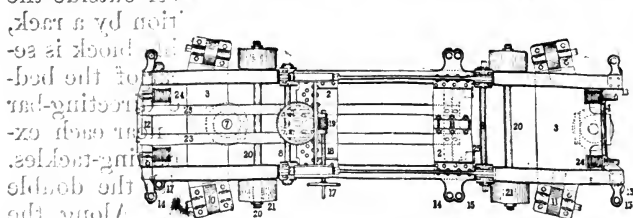

Central Recoil-Check Carriage.

operating a friction-plate which seats against two heavy bars secured to the slide. Railroad buffers are also fixed at each end of the slide.

Geared Broadside-Carriage and Slide with Hydraulic Recoil Check.

The carriage is very low, its bottom plates coming down inside the slide-rails, which are given a slope to the front. The slide is centre-port pivoting. The carriage is run out and in either by tackles or gearing. For the latter, long screw-shafts are fixed outside of the slide-rails on each side, geared by mitre-gearing to large cogged driving-wheels on the rear of the slide. A long lever is pivoted in wake of the trunnion-sockets, carrying at its lower end a half screw-sleeve. By heaving out on the lever, the sleeve engages in the screw-shaft and the gun is drawn in or out. The recoil cylinder is of the ordinary type, but provided with a circulating pipe and balanced valve by which the oil passes from one end to the other. The valve may be regulated for any desired amount of recoil. The training-gear is of the ordinary type, working a longitudinal shaft having on its outer end a cogged wheel to gear in a metal rack just inside of the rear slide-rollers.

*Ericsson's Broadside-Carriage and Slide with Friction Recoil.**

The recoil arrangement of this carriage is made up of two plates operated by a lever, and jamming between them a flat plate attached to the carriage. The carriage is run in and out by gearing, the driving-wheel engaging in racks inside the slide-rails. The training-gear is of the ordinary type, but gears directly into the slide-rollers, whose middle sections are cogged, the middle section of the circle or races being cut in a rack.

* See page 299.

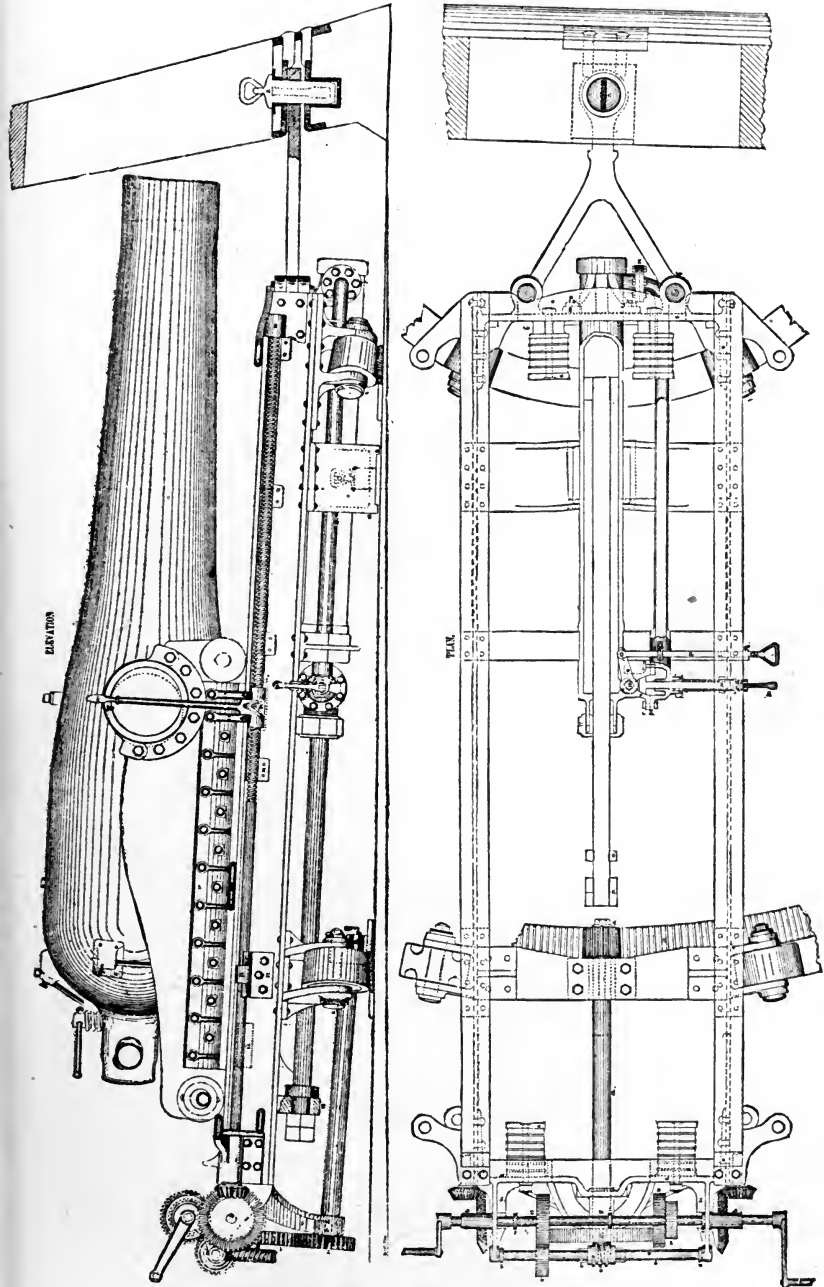

Geared Carriage and Slide with Hydraulic Recoil.

Ericsson's Turret-Carriage.

The slide of the turret-carriage consists of two bars built into the turret. The carriage is made of double plate-iron

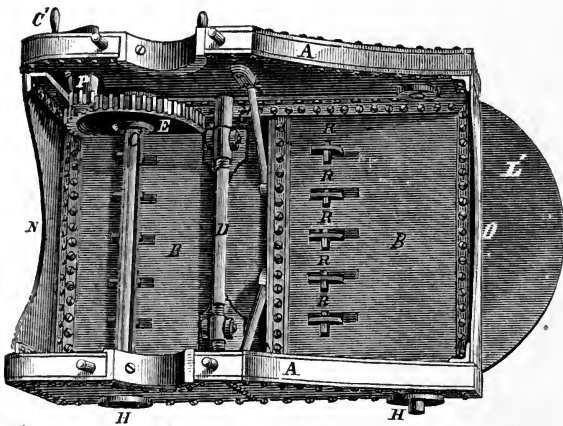

Ericsson's Turret-Carriage. (Top.)

worked on a frame. The compressor is the original of the Elswick compressor (see page 201), working on the same prin-

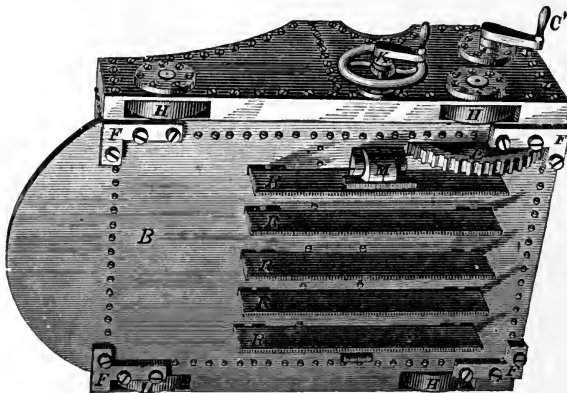

Ericsson's Turret-Carriage. (Bottom.)

ciple. The gun is run in and out by means of a large cogged driving-wheel gearing in a rack underneath the slide.

Friction-Drum Recoil-Check Carriage

The carriage and slide are similar to those of the 11-inch iron pivot-carriage, except with regard to the recoil check,

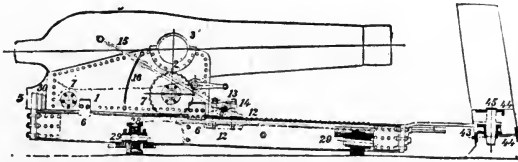

Ericsson's Friction Recoil Carriage.

which is exactly the same in principle as that of the directing-bar carriage.

GUNPOWDER.

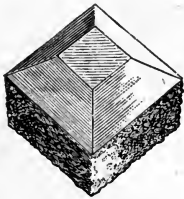

Cubical Powder.

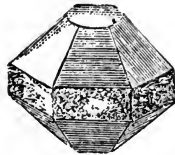

Hexagonal Powder.

Gunpowder is classed in accordance with its size of grain as follows :

Hexagonal	}	not less than 70 nor more than 75 grains to the pound.				
Cubical						
Mammoth		0.5	"	"	1	inch measurement.
Rifle		0.3	"	"	0.5	" "
Cannon		0.1	"	"	0.3	" "
Torpedo		0.1	"	"	.15	" "
Small-arm		0.05	"	"	.06	" "
Shell		.02	"	"	.06	" "

PROJECTILES.

The projectiles used with both smooth-bores and rifles are shot, shell, shrapnel, and case-shot.

All smooth-bore projectiles are of cast-iron.

All rifle projectiles except the 8-inch shot are common cast-iron; the shot are chilled-headed.

Rifled projectiles for the boat-guns (B. L.) are provided

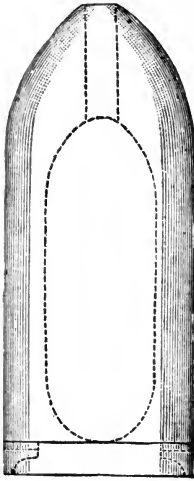

100-pdr. Parrott-Shell.

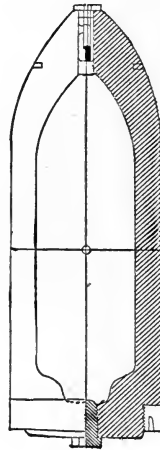

8 inch Shell.

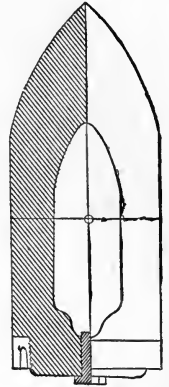

8-inch Shot.

with rotating grooved belts cast on them. They also have a rear centring ring. The rotating-rings for the larger calibres are brass rings screwing on the base of the projectile, and having an expansion groove or cup on the rear end. In the

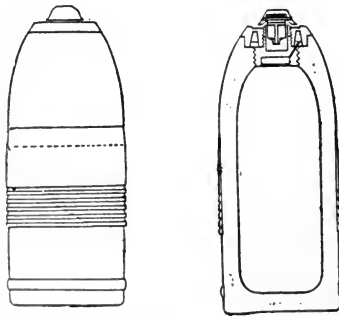

3-inch B. L. Shell.

Parrott projectiles the ring is cast on the base around a heavy dovetailed score, having jogs to prevent the ring turning on the base of the shell.

The shrapnel for the boat-guns is of the simplest description, having a thin shell and a central powder-chamber

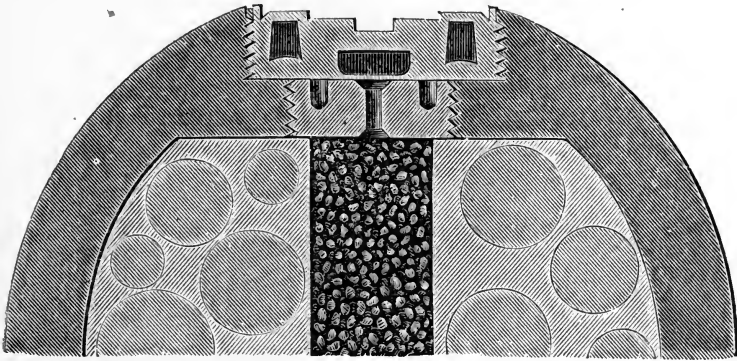

12-pdr. Smooth-Bore Shrapnel.

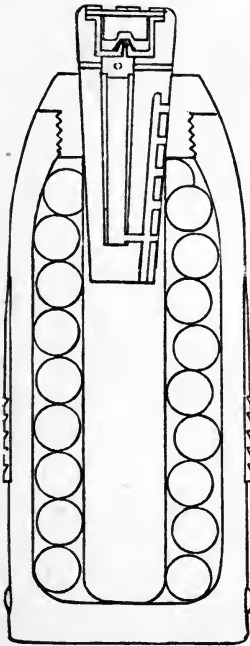

3-inch B. L. Shrapnel.

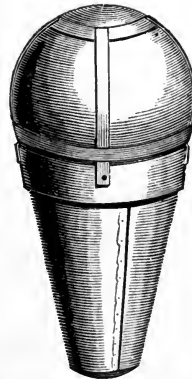

Fixed Charge for Boat-Gun.
(Shell and Cartridge.)

throughout its length. Shrapnel for the heavy calibres is similar to the English type. Case-shot is of the ordinary construction.

FUSES.

The fuses used in the navy are both time and percussion. There are three types of time fuses. The navy time-fuse, used in rifled and smooth-bore projectiles, consists of a brass fuse-case pierced by a centre hole, the bottom of which is closed by a small leaden plug simply jammed into place, called a safety-plug. On the top of this is the column of fuse composition

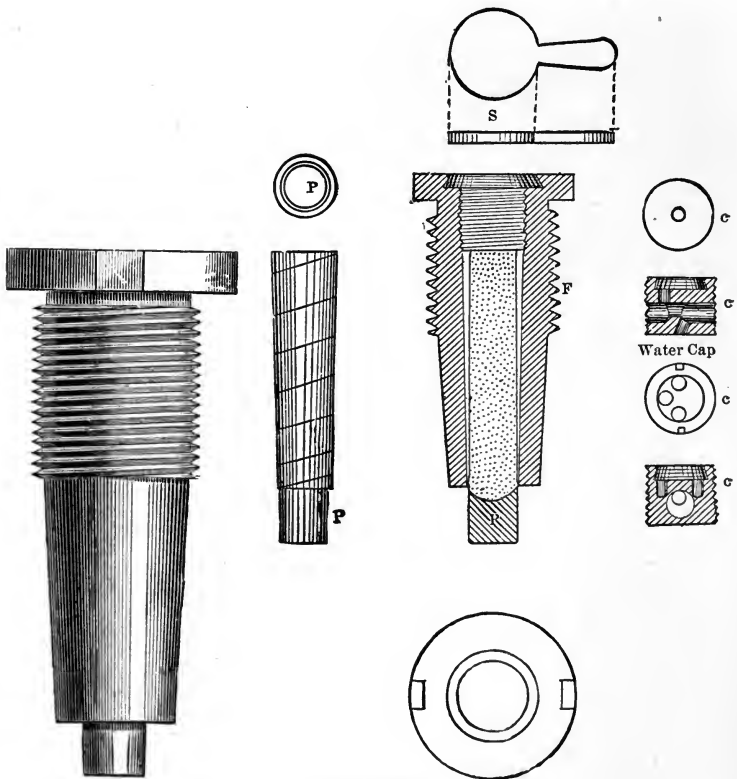

Navy Time-Fuse.

driven in a paper case. Over this screws a small metal plug, called a water-cap, having angular passages cut through it to prevent the passage of water to the flame. These holes are filled with igniting composition. Over the water-cap is secured a leaden patch, sealing the fuse. This patch is torn off when the projectile is put in the gun; the flame of discharge ignites the composition, and the projectile starting from its seat drives the

safety-plug out of its place into the shell, leaving the passage clear for the flame.

The Bormann fuse is used with the smooth-bore shrapnel. In this, the composition is driven in a horizontal cavity open-

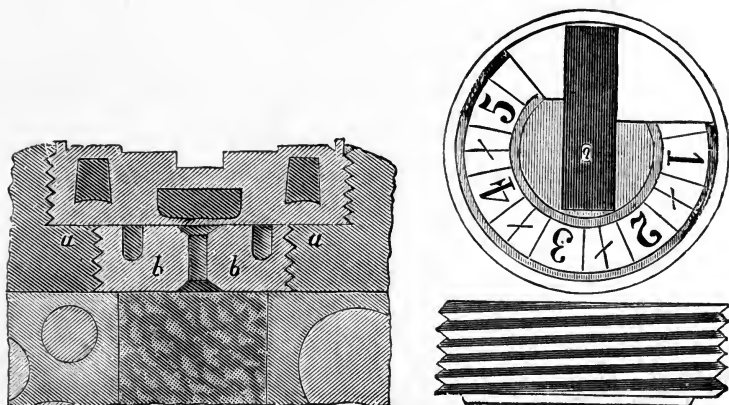

Bormann Fuse.

ing into a centre magazine. The top of the fuse is sealed, and its periphery marked to fractions of seconds. When inserting the projectile this fuse is cut, laying the composition bare at the desired time.

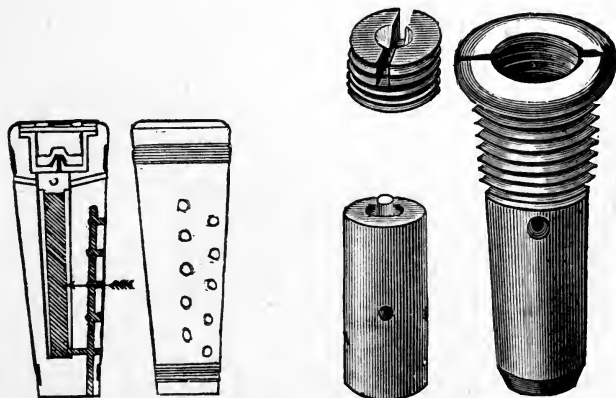

Boxer Time-Fuse.

Schenkl Percussion-Fuse.

The Boxer fuse is a wooden-cased fuse similar to its English original.

There is but one type of percussion-fuse used in the service.

It consists of a brass case containing a small iron hollow cylinder filled with composition, and having at its head a small anvil on which an ordinary percussion-cap is fitted. This cylinder is suspended midway of the case by a small brass screw through the wall of the case. The top of the fuse is closed by a small screw-cap, one side of which is hollowed in a small cavity. Ordinarily this cap is screwed in place with the cavity turned downward, so that in case the cylinder breaks from its fastening the cap cannot be struck as it enters the cavity, while the shoulders bring it up before striking. To prepare it for firing, the cap is unscrewed and reversed, putting its flat side down. When the time-fuse is used in rifled shells, the safety-plug is removed before inserting the fuse.

PRIMERS.

Both percussion and friction primers are used. The percussion primer consists of a quill tube, the upper end of which is split and spread out to form a wafer. The body is filled with fine powder, the lower end being sealed with shellac, and the wafer is filled with detonating composition, covered and sealed with shellac.

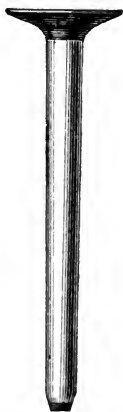

Percussion Primer.

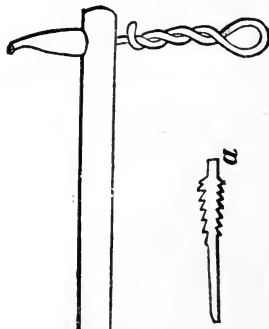

Friction Primer.

The friction primer is a quill tube filled with fine powder, and having in its head a wire igniter in contact with detonating composition. The end of the wire is twisted into a loop for the purpose of hooking a firing lanyard. A small pre-venter-loop is attached to the primer, hooking over a small pin just forward of the vent.

LOCKS.

Percussion-locks are used with all smooth-bores. They are of the ordinary type of heavy brass gun-locks, the pivot-hole being slotted so that in firing, after the lock strikes the primer it is drawn clear of the vent.

SIGHTS.

The smooth-bore broadside-guns are provided with centre-breech and reinforce sights, pivot-guns with centre and tangent sights, and the rifled guns with tangent-sights. The smooth-bore breech-sights are rectangular bars shipped with an angle to the rear so that two sides may be seen. These sights are marked on one side for ordinary and on the other for heavy charges, corresponding to shot and shell. The reinforce sights are of the ordinary pattern. The Parrott tangent-sight does not slide in a sight-box, but has a stem which seats in a casing. It is cylindrical, and the sight-notch, fixed to a ring, slides up and down the sight-bar. The sight-notch itself is a small capstan-head having four radial notches, and working on a screw perpendicularly to the sight-bar to allow for drift. The tangent-sight for the 8-inch M. L. R. is set at a permanent angle of deflection of $1^{\circ} 50'$, and is provided with a sliding leaf. The graduation on all sights except the Parrott rifles and the boat-guns is in hundreds of yards. In the remainder it is in fractions of degrees.

MACHINE-GUNS.

The Hotchkiss Revolving Cannon.

This gun is introduced into naval services with the especial objects of, first, repelling torpedo and boarding attacks; second, for use against light merchant vessels where a light, long-range artillery fire is most effective. The gun has five barrels, and can be fired at a rate of from 60 to 80 shots per minute without forcing. Its ammunition is shell and case-shot, the weight of projectile ranging from one and a half pounds in the light calibre to four pounds in the heavy one. The extreme range is about 4500 yards. The barrels are assembled about and revolve around a central axis, the cartridges being fed through a chamber in the left upper side of the breech-casing. There is but one lock, and each barrel fires once during a revolution.

The cartridge on falling into the chamber is carried forward by a cam into its barrel, being pushed close home and receiving

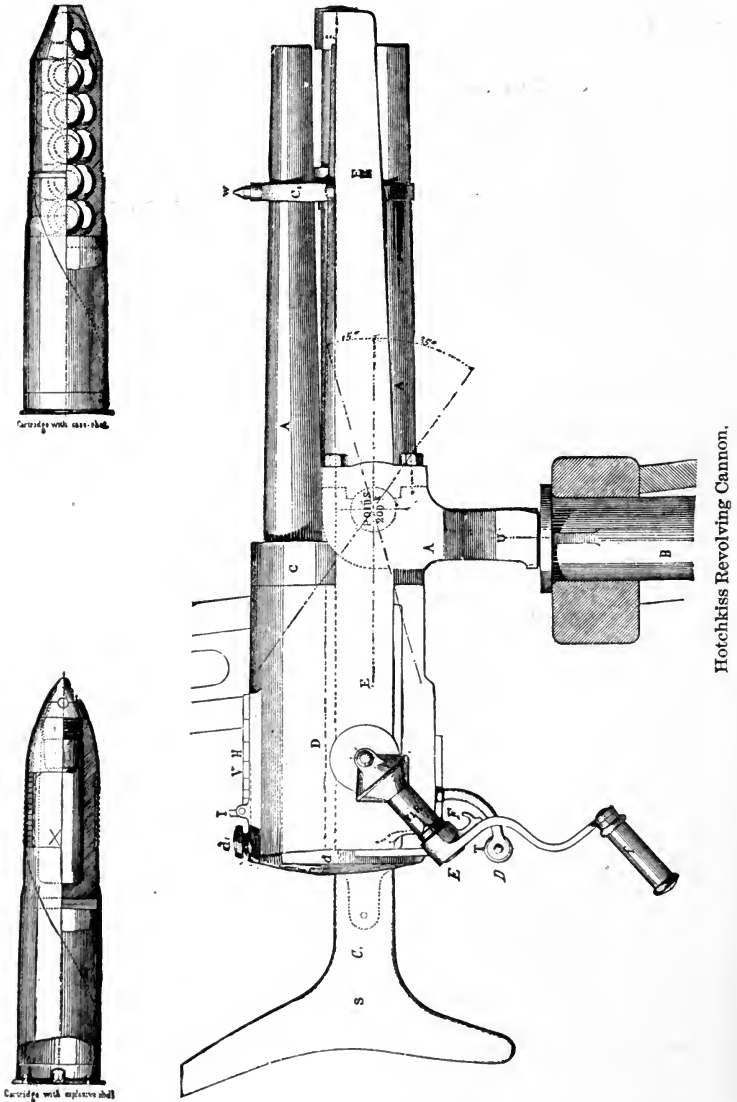

good support when passing in front of the firing-pin. The latter is retracted by a cam, plunging forward as the centre of

each cartridge comes in front of it. The rim of the cartridge-case is then seized by an independent extractor, withdrawn, and dropped to the ground. Although the crank is turned steadily, there is a certain amount of lost motion in the revolution of the barrels. This takes place as the cartridge reaches

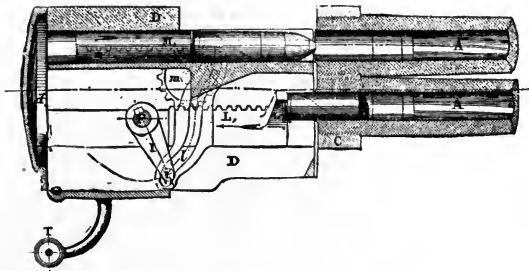

Chamber. (Longitudinal Section.)

the firing-point, and during this short time of rest one cartridge is fired and another empty case is ejected. No elevating-screw is used with this gun. It is mounted on trunnions in a saddle, and projecting from the rear of the breech-case is a wooden shoulder-piece, while underneath is a handle

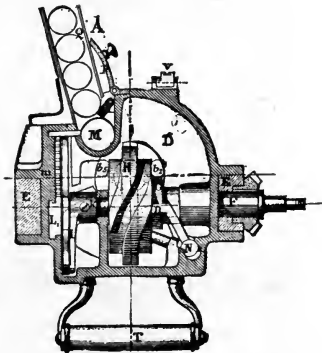

Chamber. (Vertical Section.)

to allow a support with the left hand. The cartridges are permanently attached to the rear of the projectiles. The shells are of steel with a percussion-fuse. The barrels of the gun are made of Whitworth compressed steel of the finest quality. This gun has up to the present time proved the most effective torpedo-gun in existence. Its only rival at present is the Nordenfeldt gun, which is not yet thoroughly developed.

The Gatling Gun.

This gun, which has as yet been unequalled as a mitrailleuse, finds a place in the armament of nearly all the navies of the

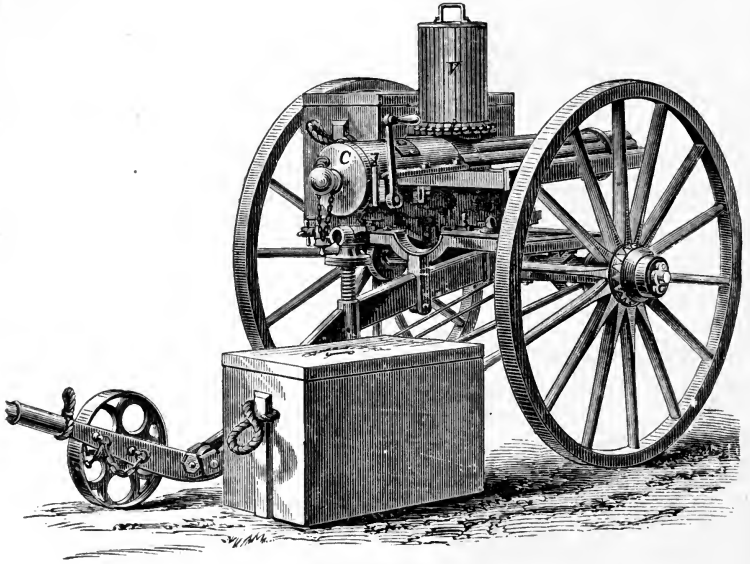

Long Pattern.

world. Hitherto the object of the gun in naval use has been simply to aid the small-arm fire whenever the latter was made

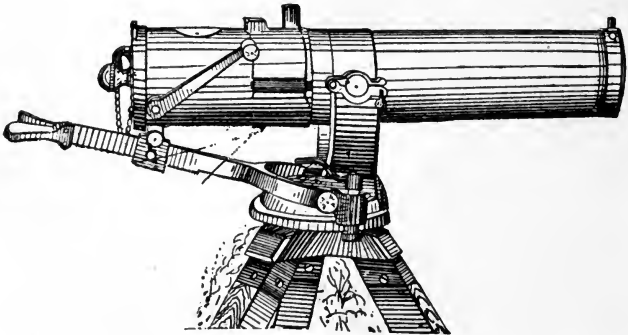

Short Pattern.

necessary, but at present it is the design to increase the calibre of the gun so as to enable it to fire projectiles of two or more

pounds. What modifications will be required in the present type of gun are not as yet known ; but although the Gatling and Hotchkiss guns are both American inventions, they must not in their present stages of development be considered as rivals. The Gatling is as a rule confined to the use of small-arm am-

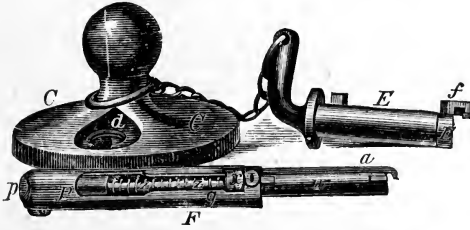

Lock, Extractor, and Breech-Cover.

munition ; on the other hand, the Hotchkiss is to be in reality classed with boat-guns.

The Gatling has ten barrels grouped about a central axis. Each barrel is provided with its own separate lock and extractor, retracted by a cam, the barrels being each fired as it comes to a certain point. The speed of firing can be carried

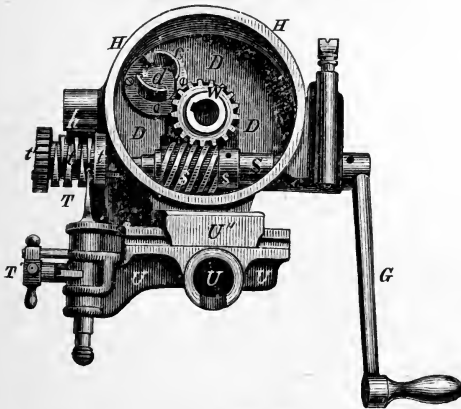

Breech Mechanism.

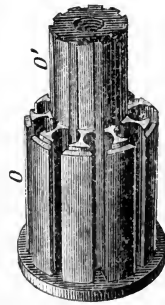

Chamber.

as high as between 400 and 500 cartridges a minute without much forcing. There are two patterns of this gun, known respectively as the long and the short gun, the latter being designed especially for use in ships' tops, while the former is used in landing and long-range firing. The cartridges are fed to the gun in tin cases holding 40 each, and which are rapidly

put in position and changed so that there is no especial time lost in removing one case and shipping another. In case that one barrel should become fouled or a lock be broken, the lock can be extracted very quickly and so no hindrance is offered to the working of the mechanism, as cartridges dropping into the

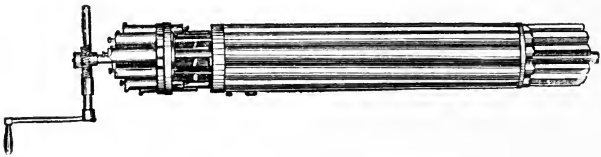

Barrels, Chamber, and Revolving-Gear.

faulty chamber are carried around and dropped out without being fired. Notwithstanding the great rapidity of the fire there is no danger of the barrels becoming too much overheated, and the great difficulty experienced in most guns of

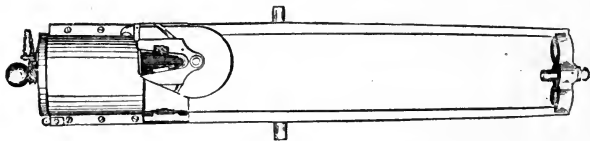

Frame and Covered Breech.

the mitrailleuse pattern of sticking and refusing to work, through the expansion of the barrels and mechanism due to the heat of rapid firing, is either fully avoided or compensated in the Gatling.

SMALL-ARMS.

Breech-loading small-arms are used in all the navies of the world, and, as with great-guns and machine-guns, although the greater nations strive to develop patterns of their own, many use the same pattern; small-arms of American manufacture being used by the majority. In many navies these arms are of two patterns, generally one of them being some system of conversion from old smooth-bores, whilst the other is a gun of a new pattern.

Types of Small-Arms in Use in the Different Navies.

COUNTRY.	TYPE.
ARGENTINE.....	Remington.
AUSTRIA.....	Werndl.
BRAZIL.....	Remington.
CHILI.....	Remington.
CHINA.....	Peabody-Martini.
DENMARK.....	Remington.
ENGLAND.....	{ Snider (converted), Peabody-Martini.
FRANCE.....	{ Tabatière (converted) Chassepot
GERMANY.....	Mausers.
HOLLAND.....	Beaumont.
GREECE.....	Chassepot.
ITALY.....	Vetterlin.
JAPAN.....	Remington.
NORWAY AND SWEDEN.....	Remington.
PERU.....	Remington.
PORTUGAL.....	Peabody-Martini.
RUSSIA.....	{ Krnka (converted), Berdan.
SPAIN.....	Remington.
TURKEY.....	{ Snider (converted), Peabody-Martini.
UNITED STATES.....	{ Remington, Hotchkiss (Magazine), Springfield (Marine Corps).

The United States Navy is the only one in which the magazine rifle has been introduced. The Springfield, used in this country by its Marine Corps, is a converted rifle. The Beaumont rifle, used in Holland, the Peabody-Martini and Snider, used in England, and the Berdan, used in Russia, are all modifications of original American types.

CONVERTED BREECH-LOADERS.

*Snider.**Tabatière.*

These two systems of conversion are almost identical, differ-

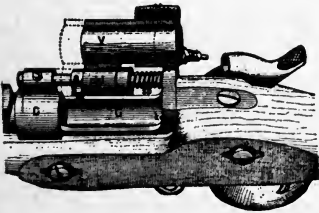

Snider.

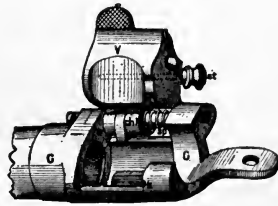

Tabatière.

ing only in one or two of the minor points. The breech-block is hinged to open transversely, the lug of the hinge being some-

what shorter than the axle, the intermediate space being filled by a spiral spring which holds the block forward. By drawing back the block against the spring after opening, the extractor which is attached to the forward part withdraws the empty cartridge-case. There is no lock on the block, the pressure of the hammer on the firing-pin holding it down.

Krnka.

This system is a Russian invention, and is exceedingly simple and compact. The breech-block revolves transversely, and the movement of opening causes the extractor, which is a

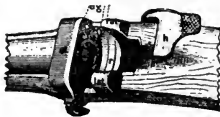

Krnka.



Breech-Block.

simple lever, to throw the cartridge-case out of the chamber. Two lugs rise in rear of the breech-block, leaving a cavity between them for the insertion and ejection of cartridges. The breech-block when closed is held down by the hammer on the firing-pin.

Springfield.

In the Springfield system the breech-block hinges at the upper forward end and is turned up. The extractor is operated by a small spring which ejects the cartridge-case forcibly on throwing open the breech-block. The firing-pin passes



Springfield.

diagonally through the breech-block to the axis of the bore. A catch holds the rear of the block down when closed, and the bottom of the block is hollowed out to lighten it.

NEW SYSTEMS.

Peabody-Martini.

In this system the breech-block is hinged at its upper rear end and drops down in opening. It is opened and closed by a bent lever in rear of the trigger-guard. The extractor is a bent lever, the lower front of the breech-block striking it in opening and causing it to violently eject the cartridge-case.

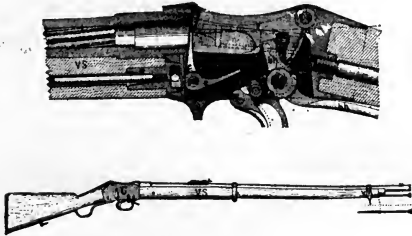

Martini-Henry.

The firing-pin is in the axis of the breech-block, and is retracted and cocked by the motion of opening the breech. By means of a small slide just in front of the trigger the firing-pin can be secured at full cock. A small pointer on the left outer face of the receiver serves as a tell-tale to show when the piece is at full cock.

Werndl.

The breech-block of this piece revolves about an axis just below the barrel, and by its revolution works the extractor and

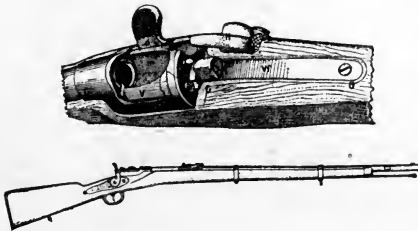

Werndl.

throws the empty cartridge-case out. The firing-pin is of the ordinary type, held back by a spring and operated by the blow of a hammer. The head of the bolt in which the breech-block revolves has for its section a segmental shape, and a flat spring

presses upwards against it. One of its flat sides presses on the spring at each extreme position of the breech-block, and by this means the block is held secure when open or shut, whilst the movement of opening is made with a snap, assisting in the ejection of the empty case.

Mauser.

The breech-block of this piece is a cylindrical block travelling lengthwise, and turned and moved by a projecting thumb-piece. A part of the right side of the slot-way in which it travels is cut away, so that in pushing forward the block to close the breech it may be turned also; projections on the thumb-piece cut with a slant, taking against the sides of the

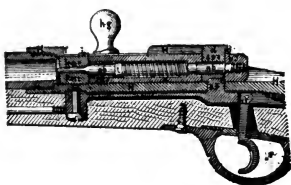

Mauser.

cut so as to force the block, close up wedge-fashion and hold it secure. The extractor is secured to the nose-piece of the block. The firing-pin travels in the axis of the block and is retracted, or rather the spring is pressed forward, as the block is drawn back, being held cocked by the sear when the block is pushed forward again. This gun is a modification of the old Chassepot.

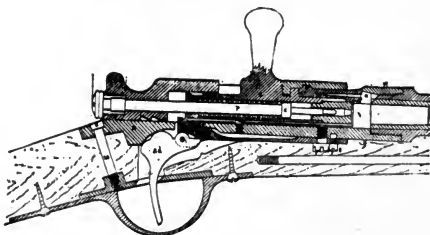

Chassepot.

Le Gras (modified Chassepot).

This gun is the same in principle as the one just described, it being in reality a system of conversion from the old needle-gun used in connection with a paper cartridge, to the new one

using brass cartridge-cases. The principal differences between the Mauser and the Le Gras are in the details of the trigger and in the use of a rubber gas-check.

Berdan.

The breech-block of this system is pivoted at the upper forward end, and is opened by drawing back the locking-bolt to its full extent and then throwing the breech-block up. In



Berdan.

drawing the bolt back the firing-pin is cocked, as in the Mauser pattern, and throwing the breech-block up operates the extractor.

Remington.

The breech-block of this system is pivoted at its lower extremity, and is held fast by a hammer-block. Cocking the



Remington.

latter, the breech-block may be thrown back, working the extractor.

Hotchkiss Magazine.

The breech-block of this system is on the principle of the Chassepot, being turned by a thumb-piece to unlock it and then retracted, the operation of retracting, cocking the firing-

pin, withdrawing and ejecting the old cartridge-case, and opening the magazine, from whence a fresh cartridge is pushed in

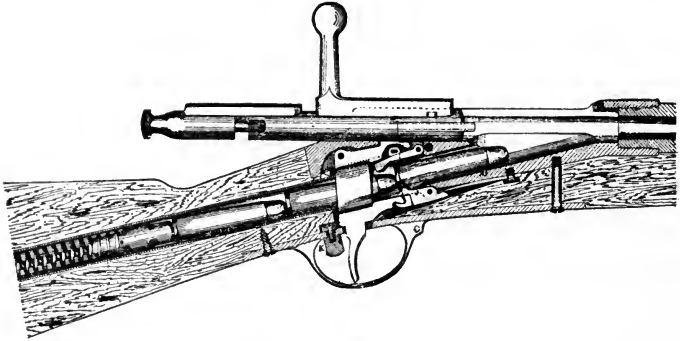

Hotchkiss Magazine.

front of the block by a spiral spring. The magazine runs along the axis of the butt-stock, and is provided with a feed-stop by which the supply may at any time be shut off.

RECAPITULATION OF NAVAL ORDNANCE.

NATION.	TYPE OF ORDNANCE.	CALIBRES.
		Inches.
AUSTRIA.....	Krupp steel breech-loaders.....	11, 10 $\frac{1}{4}$, 9 $\frac{1}{4}$, 8 $\frac{1}{4}$, 5 $\frac{7}{8}$
	Armstrong muzzle-loaders.....	9, 7
	Austrian bronze breech-loaders.....	3 $\frac{1}{2}$, 2 $\frac{1}{2}$
	Wernld (small-arms).....	0.42
	Hotchkiss revolving cannon.....	1 $\frac{1}{2}$
	Gatling machine-guns.....	$\frac{1}{2}$
BRAZIL.....	Whitworth muzzle-loaders.....	10 $\frac{1}{4}$, 9 $\frac{1}{2}$, 7, 6, 4 $\frac{1}{2}$
	Brazilian cast-iron smooth-bores.....	8, 6
	Gatling machine-guns.....	$\frac{1}{2}$
	Remington (small-arms).....	0.45
CHILI.....	Krupp breech-loaders.....	9 $\frac{1}{4}$, 8 $\frac{1}{4}$
	Armstrong muzzle-loaders.....	9, 4 $\frac{1}{2}$
	Gatling machine-guns.....	$\frac{1}{2}$
	Remington (small-arms).....	0.50
CHINA.....	Armstrong muzzle-loaders.....	12 $\frac{1}{2}$, 12, 10, 7
	Vavasseur muzzle-loaders.....	12
	Gatling machine-guns.....	$\frac{1}{2}$
	Peabody-Martini (small-arms).....	.45
DENMARK.....	Krupp breech-loaders.....	12, 10 $\frac{1}{4}$, 6 $\frac{1}{2}$
	Armstrong muzzle-loaders.....	10 $\frac{1}{4}$, 9, 7 $\frac{3}{4}$
	Nordenfeldt machine-guns.....	1 $\frac{3}{4}$
	Palmcrantz machine-guns.....	$\frac{1}{2}$
	Beaumont-Remington (small-arms).....	0.45
ENGLAND.....	Woolwich muzzle-loaders.....	16, 12 $\frac{1}{2}$, 12, 10, 9, 8, 7, 6 $\frac{1}{4}$, 3
	Armstrong muzzle-loaders.....	17, 7
	Palisser converted muzzle-loaders.....	6 $\frac{1}{4}$
	Armstrong breech-loaders.....	7, 4 $\frac{3}{4}$, 3 $\frac{3}{4}$, 3, 2 $\frac{1}{2}$
	Gatling machine-guns.....	1 $\frac{1}{2}$
	Snider converted (small-arms).....	0.57
	Peabody-Martini (small-arms).....	0.45
FRANCE.....	French breech-loaders.....	13 $\frac{1}{4}$, 12 $\frac{1}{2}$, 10 $\frac{3}{4}$, 9 $\frac{1}{2}$, 7 $\frac{1}{2}$, 6 $\frac{1}{2}$, 5 $\frac{1}{2}$
	French bronze muzzle-loaders.....	4 $\frac{3}{4}$, 3 $\frac{1}{2}$
	Hotchkiss machine-guns.....	1 $\frac{3}{4}$, 2
	Chassepot (small-arms).....	0.42
	Tabatière (converted small-arms).....	0.50
GERMANY.....	Krupp breech-loaders.....	12, 11, 10 $\frac{3}{8}$, 10 $\frac{1}{4}$, 9 $\frac{1}{4}$, 8 $\frac{1}{4}$, 6 $\frac{3}{4}$, 5 $\frac{7}{8}$, 4 $\frac{3}{4}$, 3 $\frac{1}{4}$
	Palmcrantz machine-guns.....	0.50
	Mauser (small-arms).....	0.42
GREECE.....	Armstrong muzzle-loaders.....	9, 7
	Chassepot (small-arms).....	0.42
	Hotchkiss machine-guns.....	1 $\frac{3}{4}$
HOLLAND.....	Krupp breech-loaders.....	11, 6 $\frac{1}{2}$, 7, 4 $\frac{3}{4}$
	Armstrong muzzle-loaders.....	11, 9
	Hotchkiss machine-guns.....	1 $\frac{3}{4}$
	Gatling machine-guns.....	0.50
	Remington-Beaumont (small-arms).....	0.45
ITALY.....	Armstrong muzzle-loaders.....	17, 11, 10, 9, 8
	Italian breech-loaders.....	4 $\frac{3}{4}$, 3 $\frac{1}{2}$, 3
	Hotchkiss machine-guns.....	1 $\frac{3}{4}$
	Albertini machine-guns.....	0.50
	Vetterlin (small-arms).....	0.42

RECAPITULATION OF NAVAL ORDNANCE—(CONTINUED.)

NATION.	TYPE OF ORDNANCE.	CALIBRES.
		Inches.
JAPAN	Krupp breech-loaders..... 9½, 6¾ Armstrong muzzle-loaders..... 9, 7 Gatling machine-guns..... 0.50 Remington (small-arms)..... 0.50	
NORWAY AND SWEDEN..	Krupp breech-loaders..... 10¼, 6 Finspong breech-loaders..... 10¾, 9½, 6½ Cast-iron muzzle-loaders..... 6½, 4½ Nordenfeldt machine-guns..... 1¾ Palmarantz machine-guns..... 0.50 Remington (small-arms)..... 0.45	
PERU	Whitworth muzzle-loaders..... 8½, 7, 6 Armstrong muzzle-loaders..... 9, 7 Gatling machine-guns..... 0.50 Remington (small-arms)..... 0.50	
PORTUGAL	Krupp breech-loaders..... 10¼, 6 Armstrong muzzle-loaders..... 6, 4¾ Gatling machine-guns..... 0.50 Peabody-Martini (small-arms)..... 0.45	
RUSSIA.....	Krupp breech-loaders..... 12, 11, 9, 8, 6, 4, 3½ Russian bronze muzzle-loaders..... 4, 3½ Rodman cast-iron smooth-bores..... 20, 15, 10¾, 7½, 7, 6½ Gatling machine-guns..... 0.50 Hotchkiss machine-guns..... 1¾ Krnka (converted small-arms)..... 0.50 Russian Berdan (small-arms)..... 0.40	
SPAIN	Armstrong muzzle-loaders..... 9¾, 9, 7¾ French breech-loaders..... 9, 7, 6¼, 4¾ Gatling machine-guns..... 0.50 Remington (small-arms)..... 0.45	
TURKEY.....	Armstrong muzzle-loaders..... 10, 9, 8, 7, 4¾ Krupp breech-loaders..... 10¾, 9¼, 6¾, 5¾, 3¼ Gatling machine-guns..... 0.50 Peabody-Martini (small-arms)..... 0.45	
UNITED STATES.....	French breech-loaders..... 7½, 5¼, 4¼, 4, 3½, 3 Dahlgren smooth-bores..... 15, 11, 9, 8, 6½, 3 Parrott muzzle-loaders..... 8, 6½, 5¼, 4¼, 4, 3 Hotchkiss machine-guns..... 1¾ Gatling machine-guns..... 0.50 Hotchkiss magazine (small-arms)..... 0.45 Remington (small-arms)..... 0.45 Springfield (converted small-arms)..... 0.45	

PENETRATING POWER OF ENGLISH PROJECTILES. 319

SHOWING THE PENETRATING POWER OF PROJECTILES FIRED FROM ENGLISH GUNS AGAINST IRON-CLAD SHIPS OF WAR.

EACH TARGET REPRESENTS A CERTAIN CLASS OF VESSEL AT A DISTANCE OF 30 YARDS EXCEPT WHERE THE RANGE AT WHICH PROJECTILES WOULD PENETRATE IS STATED

NOTE.— WHERE THE TARGET IS SHOWN PENETRATED BUT NO RANGE GIVEN IT INCLUDES ALL DISTANCES UP TO 3000 YARDS

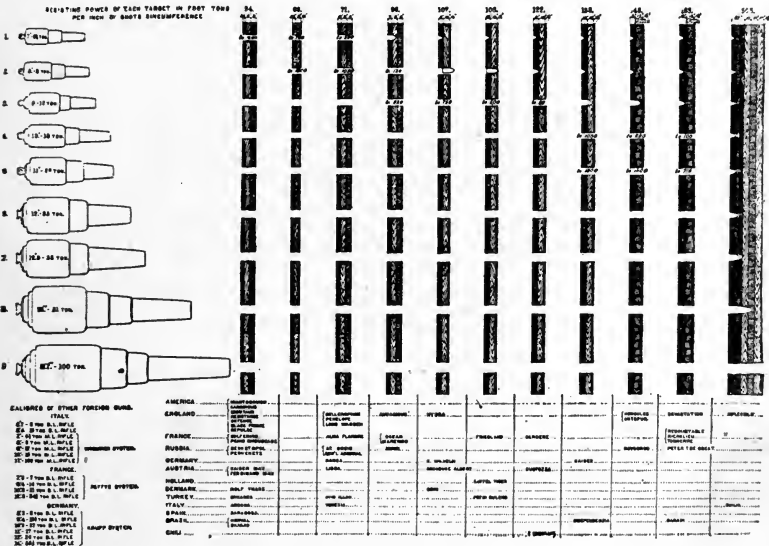

FRENCH GUNS

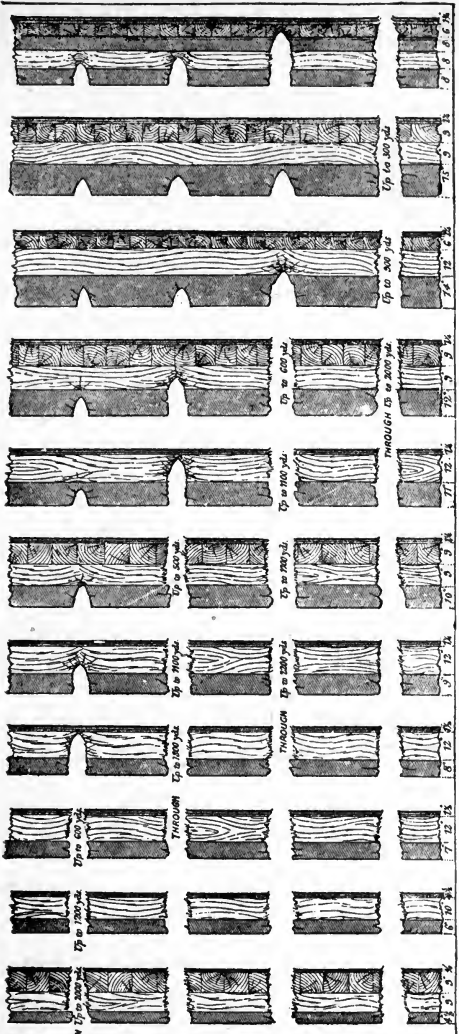
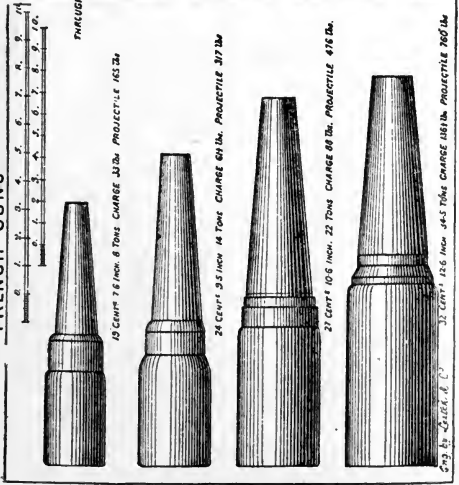

NOTE.—The upper scale is for guns $\frac{3}{16}$ of an inch to 1 foot. The lower scale is for targets $\frac{1}{4}$ of an inch to 1 foot.

322 PENETRATING ENERGY OF FOREIGN ORDNANCE.

SHOWING THE PENETRATING ENERGY, IN FOOT-TONS PER INCH OF SHOTS CIRCUMFERENCE, OF FOREIGN ORDNANCE, AT RANGES FROM 70 YARDS FROM THE MUZZLE OF THE GUN TO 1000 YARDS.

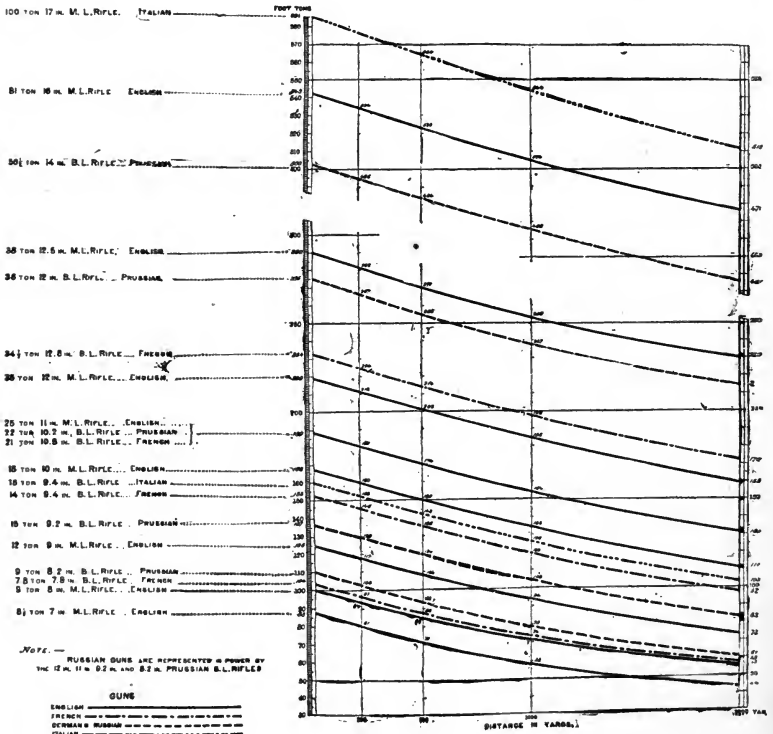

PART III.

TORPEDOES.

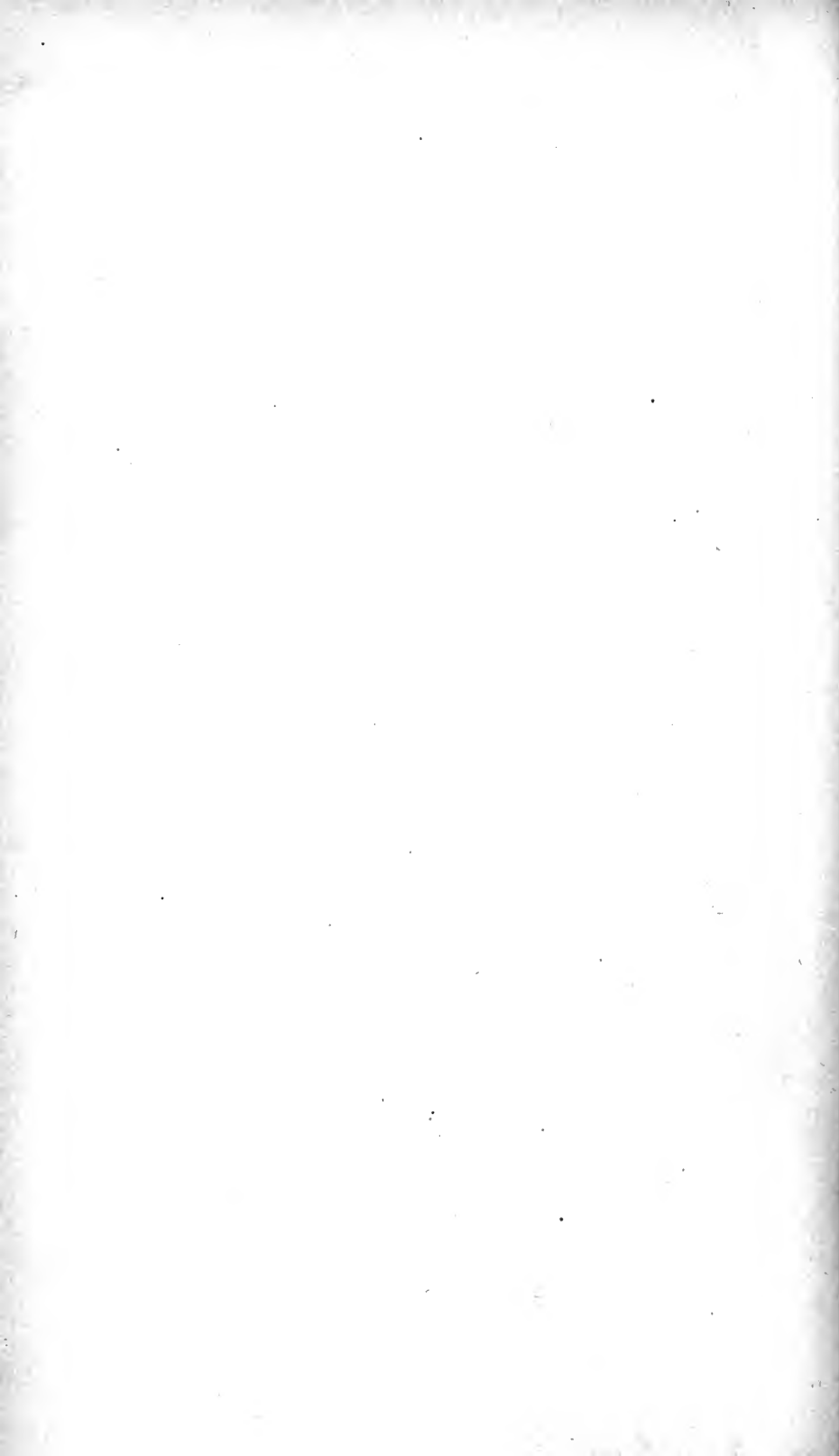

TORPEDOES.

THE torpedoes used by and against the different navies of the world may be classed under two general heads, viz., offensive and defensive.

Offensive torpedoes may be classified in accordance with the manner in which they are used, as Locomotive, Towing, Spar, and Drifting.

LOCOMOTIVE TORPEDOES.

The Whitehead Torpedo.

The Whitehead torpedo consists of a projectile, or more properly speaking a boat, containing a heavy explosive charge, an engine driven by compressed air, screw propellers, and mechanism for regulating the speed, depth of flotation, distance of run, and security of firing arrangements. The general exterior appearance of the torpedo is that of a spindle of revolution, its greatest diameter being in the middle and the lines being

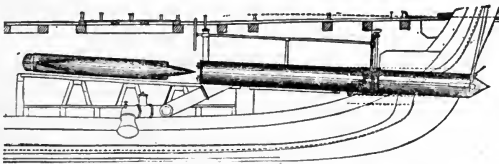

Whitehead Torpedo and Firing-Tube.

so curved as to present a surface of minimum resistance to the water. The dimensions of the torpedo range from fourteen feet in length by sixteen inches in diameter to nineteen feet by seventeen inches. The speed ranges from seven knots for a distance of eight hundred yards up to twenty-five and a quarter knots for two hundred yards, the most powerful combination being fifteen and a half knots for one thousand yards.

This torpedo, if adjusted to run at any desired depth of water of from five to fifteen feet, and if it be projected from either above water, at the water-line, or below the surface, will rapidly attain the desired depth and maintain it throughout the run. If fired in still water, it will make a straight run in the line of projection, allowance being made for the sweep of currents. It can be adjusted to stop after having run any distance up to its extreme range, and after stopping, it will sink, float, or explode as desired.

The gun-cotton charge is placed in what is termed a cartridge-case, which is a wooden case similar in shape to the forward section of the torpedo, somewhat smaller, and held in place in its compartment by wooden wedges. This charge is ignited mechanically, the arrangement being as follows: Extending from the nose of the torpedo to the cartridge-case is a tube terminating in a copper case, in which is placed the priming charge and the detonating composition; within the tube is a steel rod, two feet long, fitted with a needle-point at its inner end and having its outer end screwed into a frame; this frame is capable of moving in and out, and is connected with a spiral spring which tends to force it, and consequently the steel rod, inwards, the action being similar to that of the firing-pin of breech-loading small-arms. By compressing this spiral spring, the inner end of the frame is brought forward to a catch and held retracted. If now this catch is disengaged in any manner, the rod flies back, acting like an ordinary firing-pin on the detonating composition. The extreme forward point of the torpedo, called the nose-piece, is so fitted that it is capable of being forced inwards, but in a position of rest its inner edge is just clear of the catch. This nose-piece is provided with short horizontal and vertical arms, so as to insure good contact with the body struck. The collision of the nose-piece against any resisting body forces it back and releases the firing-pin. In order to secure against accident, the nose-piece is provided with a safety-wedge and key. Before discharging the torpedo the key is removed, and after the discharge the wedge is withdrawn by the action of mechanism, and is so arranged that it may be replaced automatically and thus disarm the torpedo after its run, in case it is desired to recover it.

The arrangement for adjusting the length of range and for drawing and replacing the wedge is as follows: Two cog-wheels, a large one and a small one, are fixed on the upper part of the after-end of the torpedo, just in front of the propellers. The small wheel has thirty teeth, gearing in an endless screw attached to the propeller-shaft, and of such a pitch that one revolution of the propeller moves the wheel one

tooth. The big cog-wheel is so arranged as to move one tooth for each revolution of the small wheel. In front of this gearing is a small stud that works fore and aft in a slot, being provided with a spring which tends to force it towards the after-end of the slot. This stud is connected by a rod to the valve which admits the compressed air to the cylinders of the engine. When the stud is in the forward part of the slot the valve is open, in the after part it is closed. By means of a lever the spring of the stud is compressed, and the stud is moved to the fore part of its slot; the big wheel is then moved around until a stud on its face is the desired number of teeth above the lever. Now for every thirty revolutions of the propeller, or one tooth of the big wheel, a certain known distance is travelled, varying according to the pattern of the torpedo, slip, etc. When the propeller has made the number of revolutions corresponding to the desired length of range, the stud on the big wheel presses against the lever of the spring and releases the latter, forcing the valve-rod back and closing the valve. Attached to the axle of the big wheel is a small brass arm which is connected by means of a brass rod to the safety-wedge, and is so arranged that after any required number of revolutions of the propeller the safety-wedge will be drawn out; or it may be drawn out at the instant of discharge. By means of an additional lever at the fore part of the torpedo, which is connected by means of a rod to the valve of the engine, and by arranging the attachment of the safety-wedge to the brass rod from the big wheel so that on the wedge being withdrawn it is released from the brass rod, the action of the closing of the valve after the run of the torpedo is completed, forces the wedge into its securing position again.

Naturally the torpedo would float at the end of its run from its difference of buoyancy, owing to the compressed air used in working the engines.

To sink the torpedo at the end of its run, a spiral-spring valve is placed in the after wall of the adjustment chamber, which can be attached to the brass rod working the engine-valve in such a way that when the latter valve is closed the spring-valve is opened, admitting water to the chamber and thus sinking the torpedo. If it is desired to explode the torpedo at the end of the run, the nose-piece is connected to the engine-valve, which, on closing, draws it violently back and releases the firing-pin. To adjust the depth of flotation, a small wheel, the face of which is marked in feet, is placed in the adjustment chamber, and is turned by means of a key until the number of feet desired comes under a pointer.

The secret of the Whitehead is in the mechanism by which

the torpedo maintains a desired depth. The adjustment chamber, which is next abaft the explosion chamber, is connected by screw to the forward and after chambers in such a manner that by means of a number of small holes bored around the circumference the faces of the chamber are exposed to the pressure of the outside water, which varies with the depth to which the torpedo descends. Within the adjustment chamber is an endless strong spiral spring, attached to the after face of the chamber, and so arranged that after being set to a certain tension, capable of resisting an equivalent pressure on the outside of the face, any increase or decrease in this pressure will cause this spring to work a rod by which the horizontal rudders of the torpedo are regulated. Within this adjustment chamber is also placed an automatic balance, which assists in maintaining the torpedo at the desired depth by swinging forward on the torpedo's descending or aft on ascending, and thus assisting the rudders.

The Whitehead may be discharged through a submerged tube in the stern or in broadside, from a carriage above the water-line, or from the surface.

For discharging under water a tube is fitted to an orifice in the stern or broadside, closed by a water-tight valve; the inner end is closed by a water-tight door. The torpedo, being prepared, is placed in the tube, the door is shut, water is admitted to the interior, and the valve is opened. The torpedo is then shot out and started by means of a piston bearing against its rear end and worked by compressed air. To prevent it from slipping out before the time, a stop is provided at the forward end of the tube, which is removed automatically at the same time that the compressed air is admitted to the piston. In the case of broadside discharge, the tube works inside an iron casing, through a stuffing-box at the inner end and in a shield at the outer end. The shield, placed on the forward side of the orifice, is of such a length as to protect the torpedo from the pressure of the water passing the vessel.

In projecting from above water, an iron carriage is used, which is fitted with a frame in which the torpedo rests. The outer end of this frame is provided with a lip a few feet long, by means of which the rear end of the torpedo is slightly canted up on leaving the frame, preventing undue strain on the extreme end. The frame is mounted in the carriage in such a way that it can be elevated or depressed by means of a screw, like a gun. The torpedo is ejected by means of a piston as before, the carriage being provided with a small reservoir of compressed air so that it may be moved to any point aboard ship.

To project from the surface, no tube is necessary; all that is

required is to set it for the depth, point it, and turn back the lever by hand, when it starts off of its own accord.

For discharging from boats, the torpedo is either mounted on its carriage forward or carried in iron slings suspended from davits. In the latter case the davits are pivoted, so that normally the torpedo rests in a cradle on deck; but the cradle being removed, the davits are swung over, lowering it to about two feet below water, where it is held securely until discharged.

The propeller is worked by means of a pair of Brotherhood engines, working to 60 indicated horse-power and giving 1000 revolutions a minute. Weight of charge, 33 lbs. gun-cotton; weight of torpedo, 500 lbs.

THE LAY TORPEDO.

The shape of the Lay torpedo is quite similar to that of the Whitehead, although it is considerably larger. As in the Whitehead, the forward section forms the explosion chamber. Next abaft this is a chamber for holding the gas reservoirs, carbonic-acid gas being the motive power. Next aft is the compartment for holding an electrical cable, which forms a constant connection between the torpedo and the operator. In rear of this is the compartment for the engines and steering



Lay Torpedo.

apparatus. These sections are separated from each other by water-tight bulkheads. The torpedo is propelled by double screws, the propellers working in opposite directions and being placed one abaft the other, the shaft of the forward one being hollow and that of the after one passing through it. The torpedo has four horizontal fins or wings, two forward and two aft; these wings are mounted on shafts or spindles passing transversely through the boat. A guide-rod or short staff is provided at each end of the torpedo to enable the operator to regulate the course. At night lanterns are hung on these rods. The electrical cable, made up of two insulated wires, is wound on a reel, and pays out through a hole in the bottom of the compartment as the boat advances. By means of one of these wires the boat is started, stopped, and steered, and by the other it is fired.

A double steering-rudder is used, one half being above and

the other below the line of the propellers; these rudders are worked by means of a small auxiliary engine, which is started, stopped, and reversed by means of the electrical current. The current passing in one direction starts the engine ahead, putting the helm to starboard. If the current is broken, the engine stops and the rudder swings amidships. The current passing in the opposite direction reverses the engine and puts the helm to port.

In the firing circuit there are two resistance-coils, one in the boat and one by the operator; the charge may be fired through either one of the coils, but not through both. When the nose of the torpedo strikes a resisting object the coil in the boat is cut out of circuit and the charge is exploded. If the operator desires to fire before striking, he can at any moment cut the coil near him out of the circuit and thus fire.

The propelling engines have a throttle-valve which controls the admission of gas from the reservoirs to the cylinders, the valve being in connection with a balanced lever. The current passing one way draws down one end of the lever, opening the valve, and passing the other draws the other end down, closing it.

In one modification of this torpedo the forward compartment or magazine is made detachable, so that on striking an object it breaks adrift and sinks a short distance before exploding, thus gaining the best depth of water. In launching these torpedoes from a vessel, a tube is provided opening below the water-line and being provided with a forward water-gate and a rear loading-door. The torpedo being put in place, the rear door is closed, the gate raised, admitting the water, and the torpedo launches itself after the engine is started. In order to sink or raise the boat, a water-chamber is supplied having a valve for admitting outside water and another for the admission of gas. By sending a current one way, the water-valve is opened and water is admitted until the torpedo is sunk to the required depth. By sending the current the other way, the gas-valve is opened and the pressure of the gas forces the water out and the torpedo rises.

The Lay torpedo may be used for clearing river obstructions, by laying out small charges in any position or by dragging a grapnel. In the latter case, an exploding charge is attached to the upper end of the grapnel-chain. When the grapnel holds fast to any obstruction the operator is notified, and by means of an electrical current he detaches the charge, which slides down the grapnel-chain and explodes at the obstruction, blowing it away.

TOWING TORPEDOES.

The Harvey Torpedo.

The general form of the Harvey torpedo is that of a box of a rectangular vertical and trapezoidal horizontal section, intended to float on end and tow at an angle from the ship's keel. The case is generally made of copper or Muntz's metal sheathed with wood; the upper inner edges being provided with shackles for attaching a towing-span. The body of the torpedo is also the magazine, large enough to hold from 33 to 58 lbs. of gun-cotton. The firing-bolt with its fuse attach-

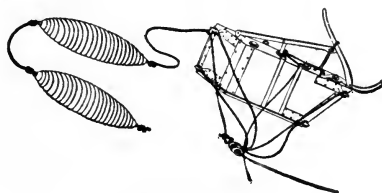

Harvey Torpedo.

ment enters the magazine from the middle of the top or deck of the torpedo. This bolt is acted upon by a series of levers so arranged that if the torpedo strikes in any position, one of the levers will drive the bolt down and explode the fuse. In the later patterns of Harvey torpedoes there is also a small rudder attached, by which the course of the torpedo is regulated when the tow-rope is suddenly slacked. The sling is made with four legs going to the corners of the torpedo and of a length

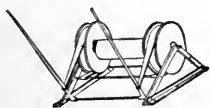

Towing-Reel.

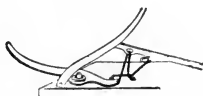

Levers.



Firing-Bolt.

to bring the centre of effort in the right position for towing the torpedo at a good angle of divergence. The firing-bolt is so arranged that the torpedo may be fired in three different ways: electrically on contact, mechanically on contact, or electrically at will. The mechanical arrangement is an ordinary chemical fuse placed in the firing-bolt in connection with a small vial of

sulphuric acid. When the firing-bolt is forced down by the contact of the levers with any resisting substance, the vial is broken by coming in contact with a stout needle and the acid ignites the fuse. For firing electrically at will, a platinum-wire fuse is used; one terminal going to earth at the torpedo, and the other passing through the firing-bolt and attaching to the insulated wire core of the tow-rope leading aboard ship. To fire on contact electrically, a resistance-coil is introduced in the circuit at the fuse in such a manner that by forcing the firing-bolt down the resistance-coil is cut out of the circuit and the fuse is fired by the short circuit.

The firing-bolt is fitted to act with a pressure of from 30 to 40 lbs. on its head, and under ordinary circumstances is secured by a key in the ordinary manner of keying bolts. If these torpedoes are left to sink of themselves, they will explode at a depth of about 60 fathoms from the pressure of the water on the head of the bolt.

In order to hold the torpedo steady when towing, it is provided with cork buoys which tow astern of it. The buoy-rope is rove through a ring at the after-end of the torpedo, and has an eye spliced in its end to which the tow-rope knots after reeving through the eye of the sling.

The firing-bolt key has a small line attached to it by which it is withdrawn whenever desired after the torpedo has been launched. The tow-rope coming from the torpedo reeves through a leading-block on a spar lashed about 25 feet above the deck, and, coming inboard through another leader, passes to a reel secured on deck and controlled by friction-brakes.

To launch this torpedo, it is hoisted by its tow-rope clear of the side, and the rope then being rapidly veered until the torpedo strikes the water and then gradually checked, it diverges at once. Veering then slowly, the torpedo takes its position at an angle of about 45° from the ship's side. In attacking a vessel, when the torpedo has been towed to within a short distance of the desired point, the tow-rope is rapidly veered and the torpedo dives; checking the rope, it rises almost immediately, and at a very sharp angle bringing up against the vessel's bilge. In case it becomes necessary to get rid of the torpedo, the tow-rope is cut at the reel and unreeves and the torpedo sinks. There are two rings for reeving the buoy-rope through, a large one and a small one. If the rope is rove through the large ring, the torpedo is lost when the tow-rope is cut; if rove through the small ring, the knot connecting the buoy-rope and the tow-rope brings up against it, and the torpedo is held up and buoyed the length of the buoy-rope below water. In securing the torpedo after the key has been

withdrawn from the firing-belt, a pair of tongs is used to grasp the bolt and keep it from being forced down.

The Menzing Towing Torpedo.

This is a modification of the Harvey, used in the German service, intended to overcome objections to the original in regard to facility of use. The general shape is slightly different, the forward end being wedge-shaped so that the torpedo may be towed on either side. This torpedo has two tow-ropes, each rove in a similar manner. The ends of the ropes are provided with two legs which are made fast to the after-end of the torpedo, where is a small rudder, the ropes coming to it and acting on it in such a manner that when a strain is brought on one it turns the rudder in the opposite direction. Secured to the bow of the torpedo is a crane, having at its end an eye through

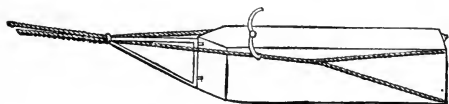

Menzing Torpedo.

which the main part of both tow-ropes reeves. If it is desired to tow on the starboard side, the starboard tow-rope is slackened, bringing the entire strain on the port one; the crane at the bow of the torpedo swings around by the strain until it brings up against a knot at the splice of the legs, thus forming with the legs a complete bridle; the divergence of the torpedo is at the same time assisted by the action of the rudder. Levers for firing mechanically are applied in much the same manner as in the Harvey. A circuit-wire for electrical firing and buoys for steadying the torpedo are also used. By these arrangements the torpedo may be towed astern until required for use, and then by slacking the necessary tow-rope it may be swung out on either quarter desired.

The French Towing Torpedo.

This torpedo is in the shape of a long box tapered at the forward end. It is made of wood, with a cork bow, the powder-chamber being hung between the cork and the main body in such a manner that it may be detached automatically. This is secured by a bolt projecting from the top of the powder-case, whose head is held by a movable plate. The slot in the plate

through which the bolt-head passes is larger than the bolt-head, so that when the plate is knocked back the bolt slips through and the magazine is detached. Two curved whiskers project forward from the plate as contact-points. In order that the torpedo may be exploded at the proper depth, two shafts are pivoted to the bottom of the float and attached to the magazine. When the latter is detached it drops down the full



French Torpedo.

length of the shafts (9 feet below the surface), and on reaching that position the electrical circuit is closed and the charge is fired automatically. To fire the torpedo at will, a miniature gun is mounted on the after-part of the plate, which is fired by electricity; the recoil draws the plate back and thus releases the chamber. The magazine of this torpedo holds 33 lbs. of dynamite.

SPAR-TORPEDOES.

The American Torpedo.

American spar-torpedoes are of two general forms. The first, for gunpowder charges, is in the shape of a long cylinder with hemispherical ends. The second, for dynamite charges, is in the shape of a large double convex lens. The powder

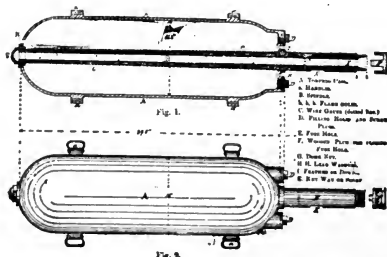

American Spar Torpedo.

torpedoes have a capacity for a charge of from 75 to 100 lbs. of small-grain powder; the dynamite ones have a capacity of from 15 to 30 lbs. In the gunpowder torpedo a large hollow spindle passes through the axis, closed and secured at one end by a large nut. This spindle is pierced with flame-holes at

short distances, so as to permit the flame from the fuse to penetrate and ignite all parts of the powder-charge at once. Around this spindle is a guard of wire gauze to prevent the powder from the charge sifting into and choking the flame-passages. This spindle projects some little distance beyond



Socket for American Spar-Torpedo.

the inner end of the torpedo-case, forming a handle or support by which the case is attached to a spar. At the inner end on each side of the spindle is a loading-hole secured by nuts and washers. There are also four handles, two on each side of the case, for convenience in transporting. The 100-pdr. torpedo loaded and fused weighs about 360 lbs. The torpedo-fuse,

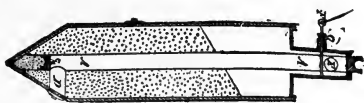

Wood and Lay's Spar-Torpedo.

which is an electric one, finds a place by itself inside the spindle, the terminal wires passing through a simple water-tight gland.

On the end of the torpedo-spar is lashed a cast-iron sleeve into which the end of the spindle is keyed. The torpedo-

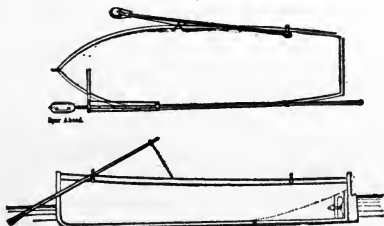

Boat-Fittings for American Spar-Torpedo.

spar for use on the bows or broadsides of vessels varies in length from 20 to 50 feet, and is supported and pointed by guys and lifts in the same manner as is common with swinging spars generally. The wires from the fuse are brought in

along the spar to the electrical machine and firing-keys arranged in suitable positions.

The spars used in boats are generally arranged on a different principle from those attached to the bows or beams of high-sided vessels. Arranged to work in a swivelled sleeve with a martingale at the rear end to regulate the depth to which they shall sink, the spar is either launched or dropped over and

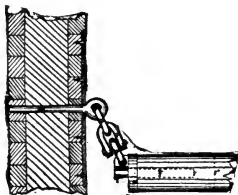

Fitting for Heel of Spar Ship-Torpedo.

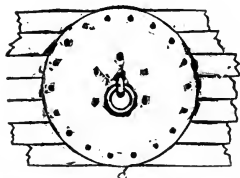

Chafing-Plate for Heel of Spar-Torpedo.

is permitted to swing without guys, the operator watching and exploding it as it is brought abeam and into the desired position by the driving ahead of the boat.

The spar used with the dynamite torpedo is an iron or steel bar of diminished cross-section in order to offer a minimum resistance to the water, with a hinged piece at its rear end bolting to the keelson of the boat and acting as a martingale.

TORPEDO VESSELS.

In several of the navies of the world gun-boats have been designed for the purpose of using torpedoes, either locomotive or spar, to the total exclusion of battery—or, in some cases, with a limited artillery—fire.

Pietro Micca (Italian).

This vessel, having a displacement of about 530 tons, is built very low in the water, with a curved deck or cover, and is not armored except as regards a deck under the curved cover and over the engines, intended to resist the penetration of plunging projectiles, and which is of laminated steel $2\frac{1}{4}$ inches thick. Her estimated speed is 18 knots, and she is provided with tubes for discharging Whitehead torpedoes ahead, abeam, and astern.

Rau (Swedish).*Ziethen* (German).*Vesuvius* (English).*Uzreef* (Russian).

Whitehead torpedo gun-boats of from 400 to 700 tons displacement and an estimated speed of from 13 to 16 knots. The peculiarity of the *Vesuvius* is in having an elbowed smoke-stack carried along the deck. The *Rau* carries a light rifled gun. All carry machine-guns.

The Alarm (American).

The *Alarm* is an iron ram gun-boat, built on the transverse bracket system, with a double bottom and water-tight bulk-heads every 25 feet. Her dimensions are: length, 173 feet; beam, 28 feet; draft, 11 feet—which may be increased by sinking the vessel to the level of the upper-deck beams, arrangements having been made for the admission and ejection of water in the compartments formed by the double hull. The torpedo system of this vessel consists of three hollow steel tubes, one projected from the end of the ram a distance of 30 feet, and one from each broadside, 17 feet. These tubes slide in and out on frames, and are worked by small auxiliary engines and winches; the torpedo is fitted to the end of the spar and is fired by electricity. The port from which the spar is projected, being below the water-line, is provided with a water-box and double doors and heavy rubber washers, which grip the spar water-tight as it is run out.

In addition to the torpedo system, this vessel is arranged to carry a 10-inch rifle forward. Her ram is strengthened, and her bow is protected for some distance by a plating of 4½ inches. On her rail she carries machine-guns to resist the attack of torpedo-boats. Her propeller is of a novel pattern, serving as steering-gear and propelling power. This vessel was originally fitted with a propelling apparatus known as the Fowler steering-wheel, a novel propeller which both gave the vessel headway and steered her. The blades of the propeller were worked by means of a simple steam-valve arrangement manipulated by the helmsman. The steering qualities with this apparatus were little short of marvellous, as she could be driven and steered with as great facility astern as ahead, and could even be worked sideways. Her speed, however, was deficient, never reaching ten knots. At present the vessel has been fitted with the Mallory steering propeller, a form of screw with a jointed shaft so that it may be revolved about a

vertical axis. This screw promises to give a speed more nearly warranted by the fine lines of the vessel.

The Intrepid (American).

This vessel is a gun-boat of about the dimensions of the Alarm, having a short, heavy ram bow and an armored belt at the water-line of five inches thickness all around. Her load draft brings her upper deck to within three feet of the water-line. This vessel carries no armament except a few Gatling guns on the rail, and her torpedo system consists of four ordinary swinging-spar torpedoes, two on each beam. Ordinarily these spars lie in crutches alongside, and they are manipulated by topping-lifts and guys in the ordinary way. The torpedoes are exploded by electricity.

The Destroyer (American).

This vessel is 130 feet long by 12 feet beam and 10 feet draft, built with a straight bow, bow and stern lines being the same and very sharp. She has no upper-deck rail, this deck being very low, with a long superstructure rising amidships. There are no openings in the sides of this superstructure, so

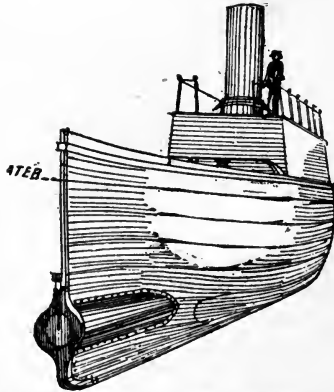

Ericsson's Torpedo Vessel (Destroyer).

that if desirable the vessel may be run with her upper deck completely under water. Thirty-two feet from the bow a heavy armored bulkhead crosses the vessel, inclined at a vertical angle of 45° , and intended as a thorough protection to the engines and boilers, enabling the vessel to approach bows on with impu-

nity. Her armament consists of a bow-torpedo, which is projected from a tube in a manner not unlike the firing of a projectile from a gun. This torpedo consists of a solid block of light wood having inserted in its forward end a heavy bursting-charge in a steel case. The transverse section of this torpedo is square; longitudinally it is a rectangle with sharpened ends. Ignition of the charge is obtained by means of a percussion-fuse. To project this torpedo, it is inserted in a tube provided with water-gates, fixed in the bow of the boat just above the keel. A steam piston-rod fits against the after-end and pushes the torpedo out with a velocity sufficient to send it at least 100 feet. The weight of the torpedo is about 1400 lbs. This vessel has been tried, but the system is not yet perfected.

The Ullan (German).

This vessel is of a novel type, consisting of two separate hulls, one within and abaft the other, the intervening space being filled with cork. She carries affixed to a ram which projects ten feet forward from the stem a dynamite contact torpedo. Arranged to travel at a high speed, the idea is to carry her at full speed against the enemy, the crew finding refuge on a small raft which she carries and which is detached just before her striking. It is not expected that the main hull, in which are the engines and steering-gear, will be injured by the explosion. The raft, it is understood, is not completely detached from the vessel, but a long tow-line is paid out rapidly, and after the explosion of the torpedo the crew haul alongside and take the boat clear ready for another attack.

TORPEDO-BOATS.

The Thornycroft Torpedo-Launch.

This boat is built to combine great speed with a moderate seaworthiness and resisting power. The dimensions range as follows: length, 57 to 85 feet; beam, $7\frac{1}{2}$ to 10 feet; draft, 3 to 4 feet. They are built of steel of an average thickness of $\frac{3}{16}$ of an inch, being completely decked over. Generally they are divided into six separate water-tight compartments. The forward and after ones are store-rooms; the second one is arranged for the accommodation of the crew; the third is the pilot-house; fourth, engine and fire room; and fifth, for the accommodation of officers. The single-screw shaft projects some distance beyond the stern-post to allow the

double rudder to work forward of it. The screw itself is of a peculiar construction, so built as to project the water straight aft instead of radially. These launches are fitted for either spar or Whitehead torpedoes. In the former case the swivelled sleeve in which the spar works pivots abreast the pilot-house. In the latter case two methods are in use. By one, a Whitehead is carried on deck on each side mounted on a carriage running on rails, by which they may be run up to a firing-case

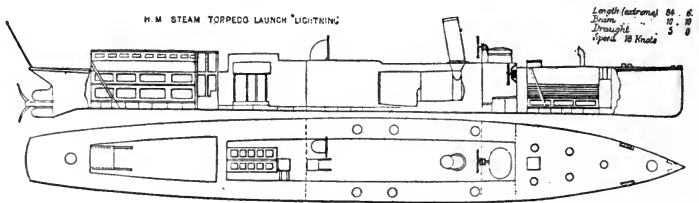

Thornycroft Torpedo-Launch.

on the forward part of the deck. This firing-case is mounted on a pivot-carriage and has depressing-gear, so that the torpedo may be pointed in any desired direction. A pointing apparatus is provided in the pilot-house by means of which allowance of angle may be made for the movements of the boat or of the attacked vessel. The pivot-circle is graduated so that the torpedo may be correctly aimed with but little difficulty. By the other arrangement, a Whitehead is carried on each side on pivoted davits in a sling, so that it may be lowered into the water; the machinery is then started by hand, and the torpedo moves off without being projected. In this case the torpedo can only be fired right ahead.

The Yarrow Torpedo-Boat.

This is a launch of the same general construction as the Thornycroft, although a higher rate of speed is attained by



Yarrow Torpedo-Launch.

this type, and there are several important modifications. The fire-room, or stoke-hole, is completely separated or bulkheaded off from the boiler, except the front part, so that in case the boiler collapses or is pierced by a shot there is no danger of

scalding the crew. The pilot-house is placed aft in the compartment occupied by the officers. There is no visible smoke-stack. Two ports are cut in the sides of the launch, one on each side, and the products of combustion may be carried through either or both. The ports are provided with valves, which are held open by the force of the blast, but which close immediately if struck by a wave. The helmsman can direct the smoke through either port, so that in approaching a vessel the one on the side next to her is closed and the smoke through the other port is partially masked by the side of the boat. When running in a seaway both these ports may be closed, and a temporary smoke-pipe is shipped in the usual place.

These boats are provided with a rudder at each end, both rudders being operated by the wheel at the same time. The forward rudder may be drawn up into a well, if desired, or in case that it gets fouled it can easily be dropped overboard. These boats have attained in smooth water a speed of 22 knots an hour. The torpedo arrangements are similar to those of the Thornycroft. Above 18 knots there is no noticeable vibration of the frame.

The Herreshoff Torpedo-Boat.

The general type of hull is the same as that of the Yarrow and Thornycroft, except that it is of composite construction,

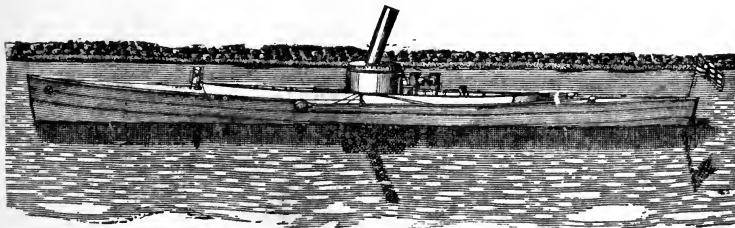

Herreshoff Torpedo-Launch.

having a steel frame with wood planking below water and steel above. The propeller is a single two-bladed screw, placed under the keel just abaft the middle of the boat, the hollow steel screw-shaft being put in on a curve. The rudder is of the balanced type, and is suspended underneath the after-part of the keel. The pilot-house is abaft the smoke-pipe. The boiler of this boat is of a novel character. It consists of a cylindrical combustion chamber about 4 feet in diameter, within which is a spiral coil of about 300 feet of two-inch pipe. This

coil is continued at the top so as to form a kind of dome under the cover of the combustion chamber. By the side of the boiler is a separator into which the steam passes before it goes to the engine. The water from the feed-pump is admitted at the top of the coil, and during its course to the bottom the greater part of it becomes converted into steam. Having passed through the entire length of the coil, the steam and water are discharged together into the separator, in such a man-

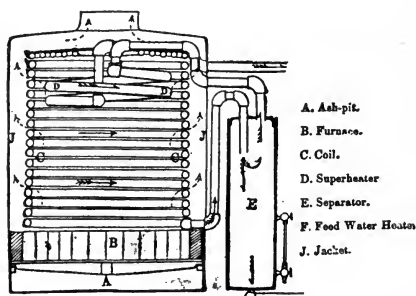

Herreshoff Boiler.

ner that the water is entirely separated from the steam and can be blown off as required. The steam is taken from the top of the separator and returns through a short coil placed inside the combustion chamber, where it becomes superheated and is led thence to the engines. By means of this boiler a good working pressure can be obtained in about five minutes from the time of lighting the fires. This boat may be rigged to carry either the Whitehead or the spar torpedoes. Its speed is about 18 knots, equal to that of the Thornycroft.

SHIPS' BOATS.

Steam-launches are at present, as a rule, fitted with spar or Whitehead torpedo-gear of a general and simple type. It is not intended that these boats should be classed as fighting torpedo-boats, as they lack the requisite speed and protection, and, as a rule, are too noisy to be of use except in a general or concentrated attack. Such boats find their greatest sphere of usefulness in clearing channels of obstructions and countermining. For the former work many are now provided with electrical valve-gear and steering apparatus, by which they may be controlled from a boat towed some distance astern, as in the manipulation of the Lay torpedo.

SUBMARINE BOATS.

At different times during the development of torpedo warfare there have been many attempts to construct and perfect submarine boats of different types, but in no case has an attempt to use one been successful. The United States corvette Housatonic was sunk off Charleston Harbor in 1864 by a submarine torpedo-boat, but there are excellent reasons for believing that she was at the time of the attack used as an ordinary surface-boat with a bow-torpedo on a spar. In most cases the boats used, or rather designed, have been propelled by hand-power, their rate of speed being very low. Attempts are being made in all countries to perfect some form of submarine boat, and, judging from the experimental success attained heretofore, it is fair to suppose that some type will finally prove successful, although in any case its use would be extremely limited.

DRIFTING TORPEDOES.

Torpedoes of this description have been used in great numbers in time of war, but only with indifferent success. The especial function of the drifting torpedo is the destruction of vessels lying at anchor, the torpedo being sent adrift at a convenient point and allowed to float either at the surface or by means of a buoy at some distance below, and by the action of the current to be carried into contact with the vessel, being exploded by a contact-fuse. There is no especial shape considered superior for this type, and generally the torpedoes are extemporized from the most convenient materials at hand. Of the many types that have been tried there are two which may be considered especially dangerous.

The first of these is a torpedo intended to be dropped by a vessel being chased, to be caught by the one in her wake. This type may be described in general as two torpedoes of a size sufficient to contain 20 or 30 lbs. of dynamite, connected by a rope or light chain bridle, and floated by flat water-colored buoys. Dropped from the stern of a vessel, the bridle is caught by the bow of the chaser, and the torpedoes being swept alongside explode against the bilges.

Lewis's Drifting Torpedo.

This torpedo, intended to reach a vessel at anchor and surrounded by a boom of logs, consists of a case of powder or

dynamite resting loosely on a small shelf attached to one extremity of a heavy pine beam, ballasting it in such a manner that it will float on end with the top just above water. The torpedo is attached to the beam by a loose chain bridle, the ends of which are stapled respectively to the lower end and just above the centre of gravity of the beam. The shelf itself is hinged, and is held in position by a catch operated by a small bell-crank lever on top of the beam. This beam on coming in contact with a boom is canted slightly, and the lever being tripped the shelf drops from under the torpedo, which, hanging by its bridle, cants the beam almost horizontally, thus allowing it to slip under the boom and float on against the ship's side, where the torpedo explodes on coming in contact.

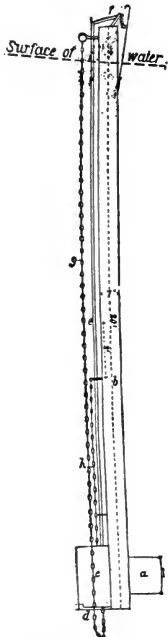

Lewis's Beam Torpedo.

DEFENCES AGAINST OFFENSIVE TORPEDOES.

Vessels at anchor in protecting themselves against torpedoes establish three separate lines of defence. The outer line consists of guard-boats; the boats of the ship, either carrying machine and boat guns or having their crews armed with rifles, patrolling the approaches to the ship at such a radius as may be well guarded by the number of boats employed. The second line consists of a boom of logs or spars arranged around the ship at a distance of from twenty to fifty feet, having in addition, wherever practicable, heavy nets which hang down below the level of the keel. The third and inner line consists of the machine-guns and small-arms of the crew, the double hull and compartment construction of the vessel itself, and powerful electric lights which at intervals sweep the water in the vicinity of the vessel, lighting up every approaching object.

DEFENSIVE TORPEDOES.

Torpedoes of this class may be described generally as being either heavy cases of explosive material resting on the bottom of shallow channels and fairways, and usually exploded at will by electrical fuses, or smaller torpedoes anchored and either buoyed or supported at from three to twelve feet below the surface. The first class of torpedoes is of crude and varied construction,

being simply heavy cases of boiler-iron of a capacity for from 100 to 200 lbs. of dynamite or 1000 to 2000 lbs. of powder, caulked water-tight and sunk generally within easy range of a heavy battery, in a position where a vessel would probably stop or anchor to open fire, or else in a shallow channel where a ship must pass directly over it.

The buoyant torpedoes are of different form ; the most successful types being

The Frame-Torpedo.

This consists of a row of heavy beams planted across a channel similar to a "chevaux de frise." The inner ends of the beams are securely anchored to the bottom, the latter giving them a support when they are run into. The outer ends carry each a single torpedo shaped like a large rifled shell and holding from 60 to 100 lbs. of powder ; bolted to it so that the tops of the torpedoes are about eight or ten feet below



Frame-Torpedoes.

water. These ends are moored so as not to swing about too much in the current. Just under the outer ends a frame is constructed to support the beams in case they get waterlogged. Contact-fuses are used with these torpedoes, and the whole arrangement serves the double purpose of acting as a torpedo and as a construction defence. These beams are also used singly in many cases.

Brooks's Torpedo.

This form of torpedo is intended to baffle attempts at removal by sweeping with drags and grapnels. The beam used in this case is of a length sufficient to allow the top of the torpedo to be at the proper distance below water when it is vertical. The heel of the spar is shod with a pointed iron casing having a ring in the end connected to an anchor-shackle, the anchor being completely buried. In this manner the beam is free to oscillate. The torpedo, which is conical with a dome

cover, ships on the upper end of the beam, all sharp corners and edges where a rope or grapnel might catch being avoided. In the top of the torpedo are placed five contact-fuses. In order to make this torpedo still more difficult of removal, it is placed in connection with a heavy ground-torpedo called a turtle-back in such a manner that any attempt to remove it from its berth causes the explosion of the turtle-back.

Singer's Torpedo.

This torpedo contains an air-chamber in the upper part, whilst all the lower portion is devoted to the charge, varying in weight from 50 to 100 lbs. of powder. On top of the case is a heavy conical iron cover loosely secured, so that if the tor-

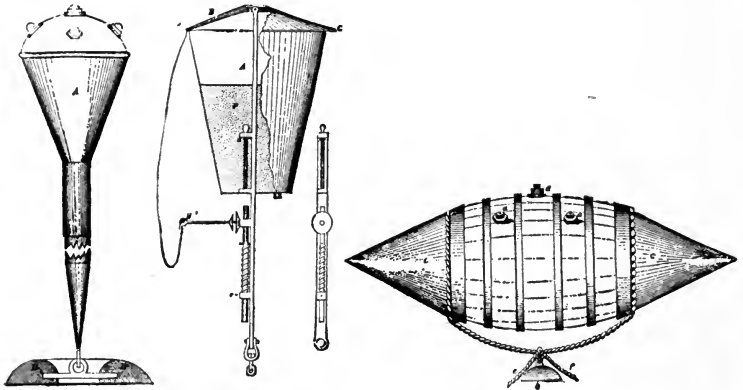

Brooks's Torpedo.

Singer's Torpedo.

Barrel Torpedo.

pedo is struck a violent blow or is canted well over it will fall off. This cover is secured by a wire to a mechanical fuse (there are several different types) in such a way that the jerk given to the wire when the cover falls off will explode it.

Barrel Torpedoes.

Barrels are frequently used as torpedoes, being thoroughly caulked and pitched and strengthened as much as possible. They are slung with rope or chain slings, moored in position, and exploded either by contact or electrical fuses. In the majority of cases with defensive torpedoes at present, they are so arranged as to be fired either by contact or at will.

TORPEDO-FUSES.

Torpedo-fuses may be classified under four different heads; viz., Percussion, Friction, Chemical, and Electric.

A percussion-fuse is one in which the flame is produced by a blow on some fulminating compound. Of such a type is the fuse of the Whitehead torpedo, which in principle is precisely that of the firing arrangement of breech-loading small-arms. The shock on the nose of the torpedo starts it back, releasing the firing-pin spring, which driving against a cap or fuse of fulminate, explodes it. The fuse of Singer's torpedo cannot depend directly on the shock of collision to explode it, as the shock might be very light. As an intermediary, therefore, the heavy cover of the torpedo is used, which falls off when the torpedo is tilted, and by its descending weight releases the lock mechanism. This consists of a firing-pin and spring secured vertically underneath the torpedo and held retracted by a small pin. This pin is withdrawn by the falling cover, permitting the firing-pin to drive forward against the bottom of the torpedo. Just over the spot where it strikes is a short rod travelling in guides, the upper end being in contact with a small capsule of fulminate, which is exploded by the shock of the outside pin.

The Torpedo Time-Fuse

is in principle a lock mechanism in which the firing-pin catch is in connection with a train of clockwork. This clockwork being set to run for a certain length of time, the torpedo is set adrift to float against the vessel or obstruction, and the torpedo explodes at the end of the time for which it is set. The original and most crude form of this type of fuse is a candle cut to a certain length, the bottom being connected to a quick-match. It is not in this case a percussion-fuse, as the quick-match communicates directly with the charge.

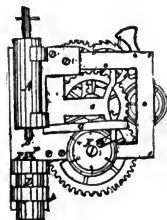

Clockwork Fuse.

McEvoy's Fuse

consists of a percussion system in connection with a small propeller. As long as the torpedo drifts with the current the propeller does not revolve, but if it is brought up in any way the force of the current starts the propellers, which after a few turns release the firing-pin spring.

The torpedo by means of which the Albemarle was sunk

(see cut, page 335) was exploded by a percussion-fuse of still a different nature. The torpedo itself was attached to the end of a spar, but just before explosion it was intended to detach and capsizes. A hollow tube passed through the axis of the torpedo, having at the nose-end an ordinary percussion-cap arrangement. The rear half of the torpedo formed an air-chamber, and at the rear end of the tube an iron ball, free to move along the tube, was held in place by a small pin to which

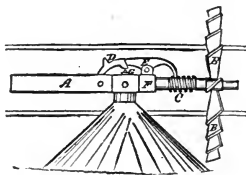

McEvoy's Propeller-Fuse.



English Dynamo-Electric Fuse.

a laniard was attached to be pulled by hand. The torpedo being thrust by the spar under a vessel was detached, and the air-chamber caused it to tumble bottom up immediately. The pin then being withdrawn by the laniard, the ball dropped on the percussion-cap and fired it.

Hill's Fuse

consists of a brass body having a percussion anvil screwed into its lower end. A spiral spring surrounds this anvil, projecting slightly above it and forming a seat for a light case holding the fulminate, which is of a very sensitive composition. Covering the top of the fuse-case, and just clear of the fulminate-case, is a light copper dome. A slight blow on this dome presses it in and drives the fulminate down on the anvil.

McEvoy's Improved Percussion-Fuse

consists of a fuse-case containing an ordinary spring gun-lock, nipple, and percussion-cap. The hammer of the lock is held back by a vertical rod free to travel in a guide. On top of the rod is a ball held in place lightly by the upward pressure of a spring. In case that the torpedo is struck and tilted over the ball falls from its seat on the rod, the latter is forced up by the spring, releasing the hammer and exploding the percussion-cap.

Friction-Fuses.

Friction-fuses as a rule consist of some arrangement by which an ordinary friction cannon-primer is exploded. This is done

by attaching a firing laniard to the friction-bar of the primer and either leaving it free, so as to fire at the will of the operator, or attaching it in such a way that the momentum of a vessel



Barrel Torpedoes with Friction-Fuses.

catching it will pull it. McEvoy's improvement on Singer's percussion-fuse consists in attaching the laniard of a friction primer to the heavy cover.

Chemical Fuses

are those in which substances separated until required for action are then brought into contact and unite chemically with an explosive effect.

Sulphuric-Acid Fuse.

This fuse consists of a brass fuse-case containing the magazine and crowned by a thin lead cylinder containing the chemicals, which consist of a small closely sealed glass phial of sulphuric acid placed in the tube and packed with a mixture of potassium chlorate and loaf-sugar. A slight blow on the lead cylinder breaks the bottle, thus permitting a contact between the explosive mixtures.

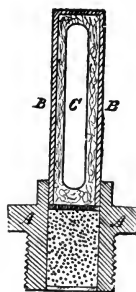

Chemical Fuse.

Harvey's Torpedo-Fuse.

The principle of this fuse is precisely similar. The bottom of the firing-rod is in this case hollowed and partially packed with the potassic chlorate and loaf-sugar mixture. Over it a small bulb containing a few drops of sulphuric acid is placed and packed carefully with raw cotton. The mouth of the hole is then sealed with a lead capsule. The firing-rod is itself suspended over a firing-pin against which it is driven by the levers on the top of the torpedo.

Electrical Fuses

depend upon the heating powers of an electrical current to ignite certain explosive substances, preferably gun-cotton. Although there are many modifications of the electrical fuse, they almost without exception agree entirely in general make.

Two current wires are necessary, called terminals, and having their inner ends separated, in order that some substance offering a high resistance to the passage of the current may be inserted between them. The terminals are of copper wire; the resistance material or bridge is generally of fine platinum wire, although other substances are used in different types. The terminals are as a rule separated by a small block

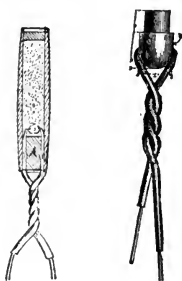

American
Dynamo-Electric Fuse.

English Dy-
namo-Electric Fuse.

of hard wood which forms an insulator and a support. Around the bridge a wisp of gun-cotton is generally wrapped, although here again other explosives are used in modified forms. This combination is called an exploder, and it is inserted in a fuse-case or magazine containing powder or gun-cotton. The exploder and magazine together form the fuse. One of the terminals is generally attached to the exterior of the torpedo, which forms an earth; the other one is connected with an insulated wire or cable leading to the electrical battery. These fuses are made to explode either at will or on contact. If they are to explode at will, the firing circuit as a rule is not completed until the moment desired for explosion. If they are to explode by contact, the general manner of use is to insert in the circuit at some part a resistance-coil of sufficient force to weaken the current below the firing point. At the moment of contact, the resistance-coil is automatically cut out and the torpedo is fired. Another way is to use what is called a circuit-closer, which normally leaves the circuit broken, but on being touched the circuit is closed and the torpedo is fired.

One advantage of the electrical fuse is the facility with which the whole circuit may be examined at any time to test its condition. It is simply necessary to send a very weak current through the circuit, and, the resistance being known, the length of the circuit can be measured electrically and the position of flaws may at any time be located. The modifications of the different fuses depend in a great manner upon the type of generator of the current, as voltaic batteries, dynamo-and magneto-electric machines are used according to the position of the torpedo.

CLEARING CHANNELS OF TORPEDOES.

The greatest skill and care is necessary in attempting to clear a channel of mines and torpedoes. Light-draught boats,

launches, gun-boats, drag-nets, grapnels, and materials for handling torpedoes at a distance of thirty or forty feet are indispensable. Torpedoes of the Brooks class may be dragged over many times and escape notice. The frame-torpedo requires the aid of counter-mines or large torpedoes extemporized and sunk on them to blow them to pieces. The shallow water both sides of the channel must be carefully and thoroughly dragged for leading wires. Boats on search must proceed with frames rigged from their bows to catch and explode torpedoes in advance. Deep-draught frames of timber must be dragged up or floated down a channel. Muddy bottoms must be thoroughly sounded, and after the search is complete deep-draught vessels cannot pass through suspected channels without torpedo-catchers rigged from their bows. Too close an examination of a torpedo after it is picked up must be avoided. It may almost invariably be easily and safely exploded, and no better disposition can be made of it.

EXAMPLES OF THE USE OF TORPEDOES DURING THE PAST
TWENTY YEARS.

Whitehead.

Sent from the British frigate *Shah* against the Peruvian iron-clad *Huascar*, May 29th, 1877. During the running fight between these vessels, the *Shah* discharged a Whitehead from a bow tube under water, which failed to reach the *Huascar*, the reason given being that at the moment of firing the latter changed her course. It is to be presumed that the torpedo in this case was carefully aimed, as there was no cause for great hurry. The *Huascar* could not be aware of the moment of firing, and the failure appears to demonstrate the great difficulty of using this type of torpedo between rapidly moving vessels at distances of eight hundred yards or over.

Sent from Russian steam-launches against Turkish iron-clads off Batoum, December 28th, 1877. The Turkish vessels in this instance were lying at anchor, surrounded by booms of logs and vertical timbers, and having guard-boats out. The Russian launches succeeded in passing the guard-boats and approaching to within less than a hundred yards of the Turks before they were discovered. Two Whiteheads were then launched at one iron-clad, missing their mark completely, both being found on the beach, unexploded, next morning. The attributed causes of the failure were non-familiarity with the complications of the torpedo itself, darkness, and a slight swell.

Sent from Russian torpedo-launches against a Turkish revenue vessel, January 26th, 1878. In this instance the torpedo-launches were entering Batoum harbor with the intention of attacking the iron-clad fleet, when they were met by a revenue steamer coming out. Whiteheads were discharged at a distance of less than one hundred yards, and the steamer was struck and sunk.

The Lay torpedo has never been used in war.

Towing-torpedoes were used on several occasions by the Russians against the Turks, but never successfully.

Spar-Torpedoes.

Attack by a steam-launch armed with a spar-torpedo on the Confederate iron-clad Albemarle, October 27th, 1864. The Albemarle in this instance was secured to a wharf and surrounded by a boom of logs at a distance of about thirty feet. The Federal steam-launch approached within one hundred yards of the boom without being discovered. Fire then being opened on her, she started ahead full speed, *passed* the ram, and made a complete turn in order to get speed and direction for striking the boom a fair blow. Hitting the boom, the launch breasted it in several feet and mounted it, evidently coming to a stand-still. At this moment, and whilst under a close fire, the torpedo-spar was pushed under the ram and the torpedo was exploded fairly, thus sinking her. In this case success was due entirely to a cool and deliberate execution of a thoroughly developed plan.

Attack by Russian launches armed with spar-torpedoes on the Turkish monitor *Duba Saife*, on the Danube, May 26th, 1877. In this attack the launches passed the guard-boats without being seen. The monitor was not protected by booms, and two launches, making a dash at her from opposite sides, planted their torpedoes fairly, exploded them, sank the monitor and escaped.

Attack by Russian spar-torpedo boats on the Turkish fleet at Sulina, June 10th, 1877. There were six torpedo-boats arranged in two divisions in this attack, the two fastest boats leading. These leaders reached to within thirty yards of the Turks before being discovered.

Fire was then opened on them. The first boat, coming down on the bow of one of the monitors, fouled her cable and swung alongside; her torpedo was exploded, but not being put in proper position no damage was done. The boat succeeded in getting clear, but was sunk by the Turks and the crew captured. The other boat succeeded in exploding her torpedo,

but also failed to get it in position. The other division of boats did not follow up the attack.

Attack on a Turkish monitor off Rustchuk by a Russian Thornycroft boat. In this attack the Russians approached very closely before being discovered. Fire was opened on the boat and the circuit-wires of the torpedo were cut, rendering it harmless; the boat escaped.

Attack on Turkish monitors at Soukum Kaleh, August 24th, 1877. Four torpedo-boats, taking advantage of an eclipse of the moon, dashed into the Turkish fleet. They were discovered at a distance and a heavy fire was opened on them, driving them off. One boat exploded her torpedo, but it was not properly placed and did no harm.

Attack by a spar-torpedo boat on the United States frigate *Minnesota*, April 9th, 1864. In this attack the *Minnesota* was unprotected; the torpedo-boat was discovered about fifty yards away and fire was opened on her. Her torpedo was properly planted and exploded, damaging the frigate considerably, but the charge was not heavy enough to sink her.

Attack by a spar-torpedo boat on the United States corvette *Housatonic*, February 17th, 1864. The boat used in this attack was in reality a submarine boat, but there are good reasons for believing that on this occasion she was used as a spar-torpedo boat. She was discovered about fifty yards away, but there was no time to open fire on her. She planted her torpedo fairly and exploded it, sinking the vessel and herself at the same time.

Besides these attacks there were several during the American civil war, in which the boats were discovered at a distance and driven off.

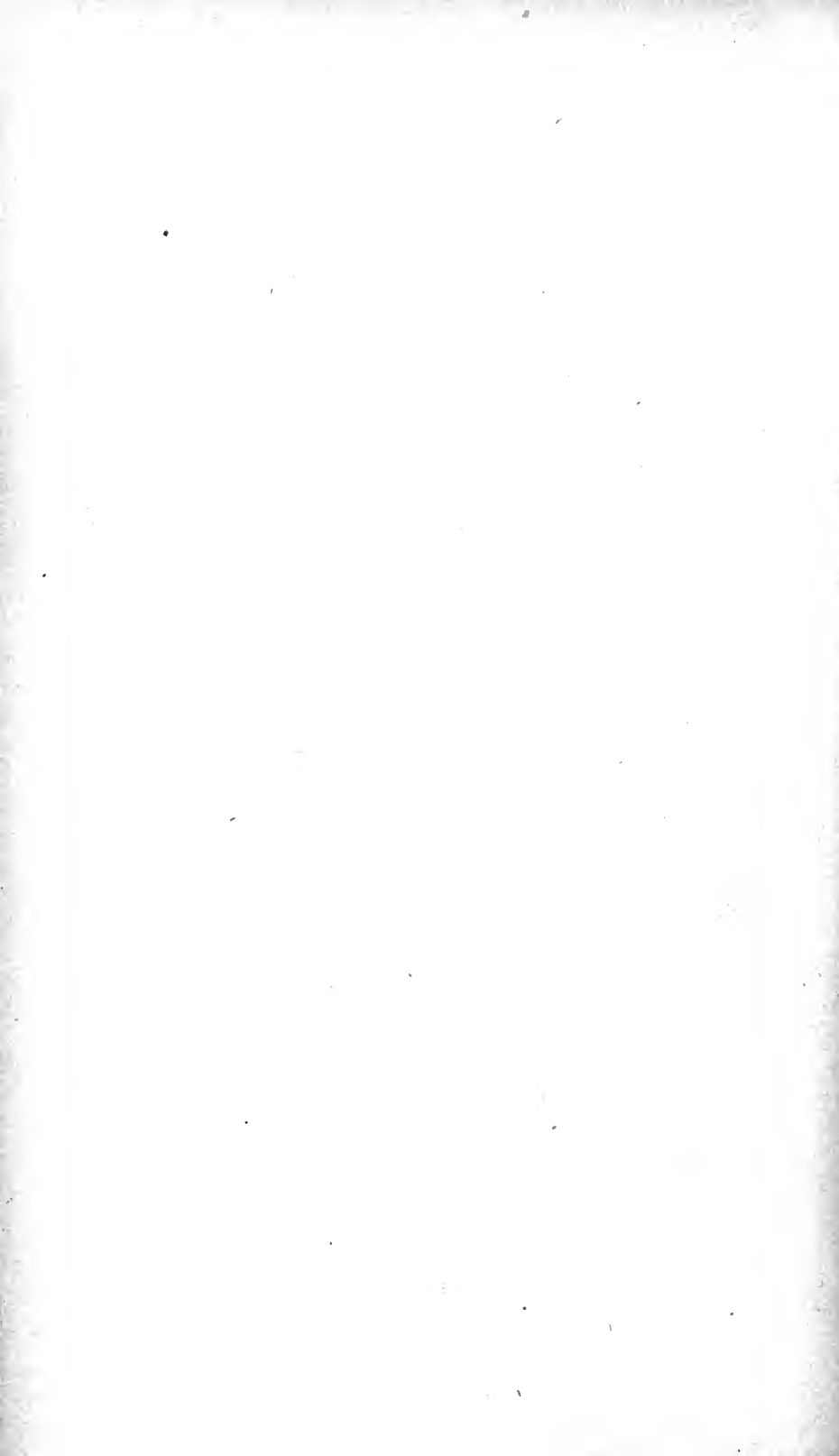

PART IV.

ARCHITECTURE AND CONSTRUCTION.

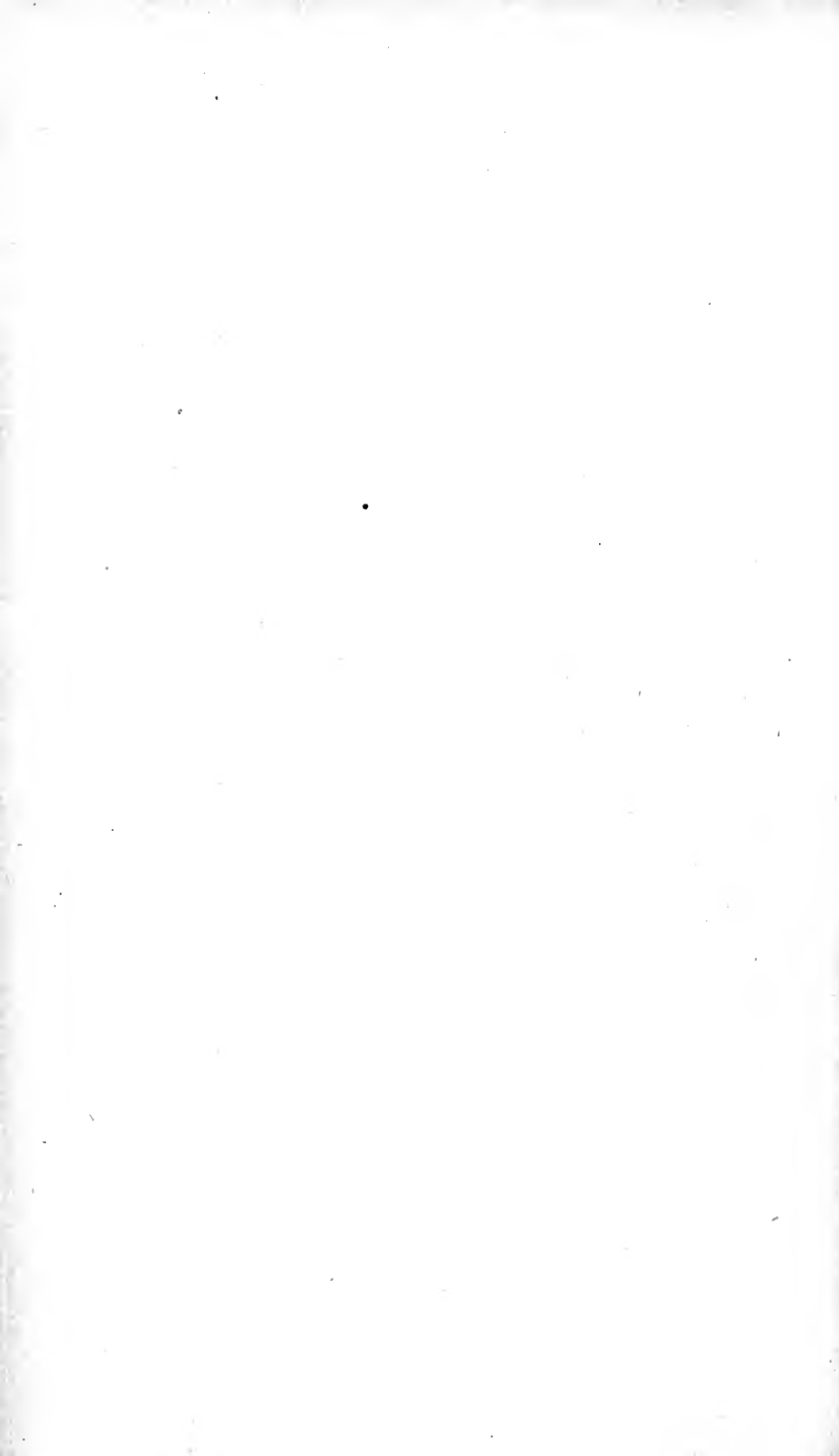

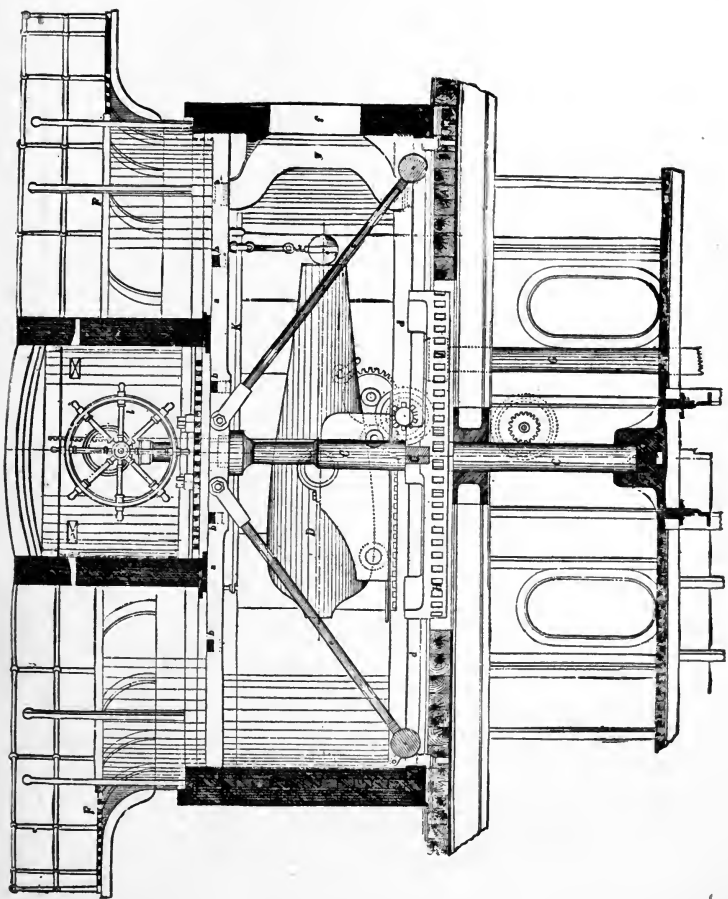

American Revolving Turret (Ericsson's System).

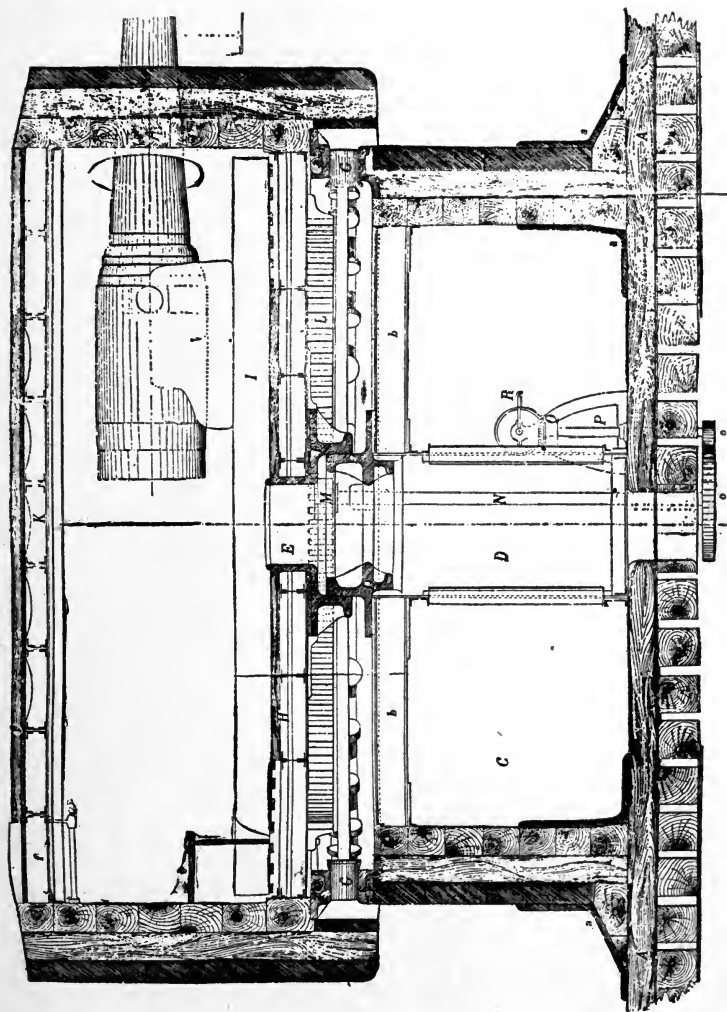

French Revolving Turret.

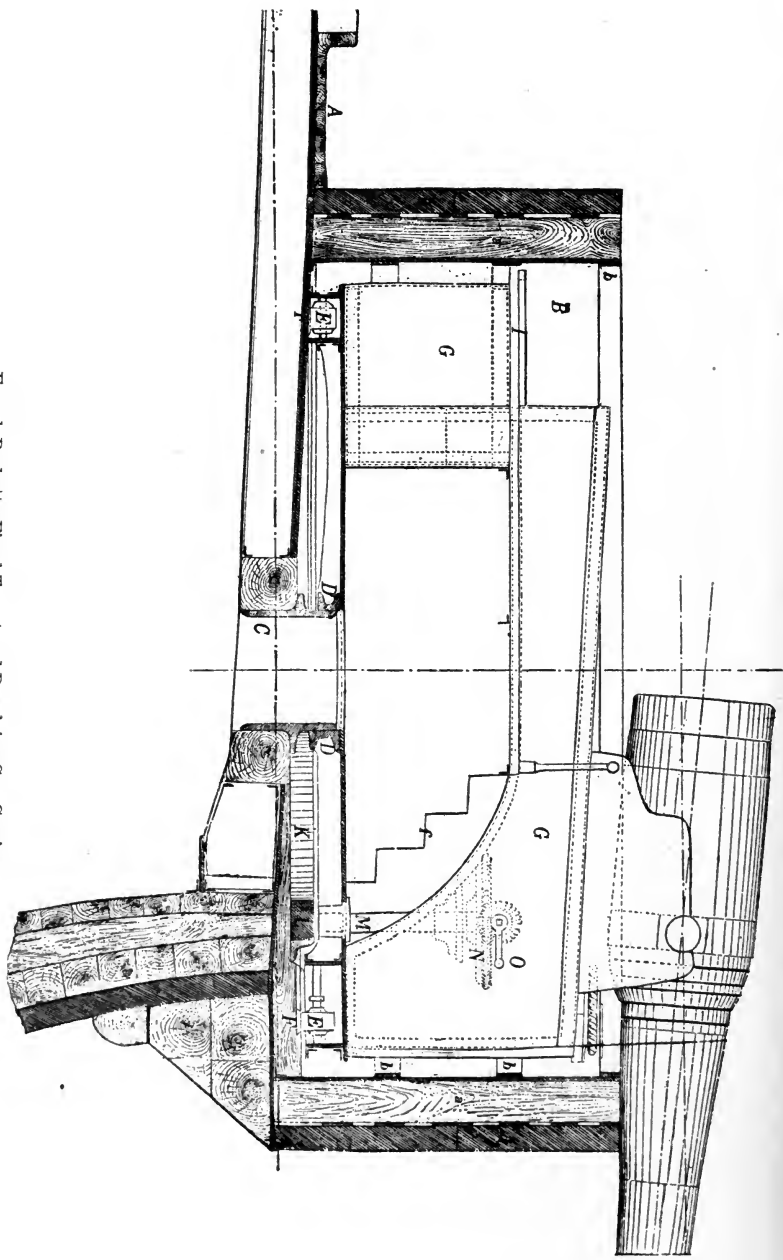

French Barbette Fixed Turret and Revolving Gun Carriage.

ARCHITECTURE AND CONSTRUCTION.

UNARMORED FLEETS.

ARCHITECTURAL DEVELOPMENTS.

EVER since the introduction of steam propulsion in ships of war, England, France, and the United States have taken the lead in the development of types of naval vessels, and in examining the various methods followed it is necessary to at first fully understand the conditions under which each nation acted and the obstacles against which each had to contend.

In Great Britain the navy has always been considered the main defence. Its support and development have for over two hundred years been considered of the first importance, and, in legislating for its maintenance, expense has seldom been spared. Since the Crimean war, no sudden strain has been imposed upon its administration tending to limit development to certain especial types. Experiments have been carried on with equal profusion in all types, from the line-of-battle ship to the gun-boat, and as each experiment resulted in the addition of a vessel to the fleet whose lifetime could be estimated safely at fifteen years, we find in this immense navy a most heterogeneous collection of ships, which it would be impossible to classify distinctly. Although this heterogeneity is a certain sign of extravagance, it by no means follows that it is a sign of weakness in the fleet itself. In all this range of liberal experiment there has been but one point where Great Britain has been really hampered, and the true advantage of a certain amount of restraint is well exemplified in the superiority of development brought about by it in this instance. In order to keep the fleet constantly up to the standard in number of vessels, a greater expenditure of timber was required than could be supplied by home production. It was easily foreseen that in case of a foreign war no dependence could be placed upon a constant supply from abroad, and to remedy this evil we find Great Britain the first to utilize iron in ship-construction, and

battling against the first and apparently insurmountable obstacles to carry iron ship-building to perfection, making it immeasurably superior to wood, and through its use extending the range of architectural development far beyond the old limits.

In France there has always been a generous system of legislation for the support of the marine, but in this country the navy has never been considered of the vital importance to the safety of the nation that it has in England; consequently naval controllers have always been obliged to exercise a much greater economy in development, and the rigidly mathematical system of the French in the exercise of all control is nowhere better exemplified than in the development of their fleet. The ships of the fleet will be found most rigidly classified, each type being clearly distinct. Reconstruction and development is carried on as it were *en masse* in accordance with the prescriptions of fleet programmes carefully studied out to meet the exigencies of the time, and once settled upon being rigidly followed to the end. It is on this account that the French are found as a rule backward in introducing radical changes of detail. Whilst keeping to their systems of classification, the French have kept close to the English in the matter of fleet strength. There has been one period in which France fell so far to the rear as almost to take third place in strength of fleet, whilst development ceased entirely. This was caused by the disastrous Franco-Prussian war, from whose effects the navy still suffers, although it has fully regained its former position close to that of Great Britain.

In the United States, naval development has been constantly hampered not only by parsimonious legislation but by a constant legislative meddling, imposing a restraint far more injurious than lack of funds or the distractions of war itself. At no time has the strength of the fleet been sufficient to bear a comparison with that of either England or France, but in the matter of architectural development the United States has repeatedly passed to the front at a single stride. In spite, however, of the advantages gained, parsimoniousness and political meddling have invariably interfered to hold the navy fast at its single stage of advance until its first developments sank into insignificance beside the modifications and perfections applied in Europe. During the Crimean war American architects laid down a programme for an efficient steam fleet and led the world in the development of the steam frigate and corvette. Notwithstanding this start, the outbreak of the civil war in 1861 found the navy with but the nucleus of a steam fleet. Whilst sailing war-vessels had almost disappeared from

European navies, giving place to steam types founded mainly upon the principles which had given American architects the lead, the bulk of the United States Navy was still composed of the old sailing frigates and sloops. The turreted iron-clad, the river gun-boat, and the rapid cruiser again showed the way to the world; but the close of the war brought demoralization to all systems of development.

In 1865 the United States possessed a fleet fully able to protect the whole line of its immense sea-coast against foreign aggression; in 1870 the fleet was reduced to a handful of vessels that, whilst showing heterogeneousness equal to the English fleet, did not possess a single element of strength.

At the date of the outbreak of the Crimean war, the building of sailing war-vessels may be said to have ceased throughout the world. Steam corvettes and frigates formed the bulk of the effective fighting fleets, whilst steam line-of-battle ships were being slowly introduced, as yet scarcely beyond the experimental stage. The introduction of steam propulsion and the advancement in the science of naval architecture had given rise not only to improvements in design, strength, and seaworthiness of men-of-war, but also to a gradual increase in dimensions of the different classes. The extent of this advancement is well shown in comparing the English line-of-battle ship *Victory*, Nelson's flag-ship at Trafalgar, having a displacement of less than 2900 tons, with the *average* displacement of English first-class frigates in 1854, which was not less than 2800 tons; the battery power of the frigates being more than twice as effective, steam-power being added, and handiness and speed under sail alone being much superior. Progress in this direction had been made to the extent that in 1854 the French had laid the keel of the *Imperatrice Eugénie*, a frigate of 3600 tons displacement, designed for a speed of 12 knots and a battery of 56 guns (five and six inch smooth-bores). At the declaration of war with Russia neither the English nor the French navy was in a condition to meet the suddenly created exigencies; both fleets were in a transition state from sail to steam. The necessity for steam-power on all ships was suddenly made forcibly apparent, and architectural development ceased almost entirely in the work of converting all the available line-ships and frigates of the old sailing fleet into steamers.

This total extinction of sailing vessels as fighting war-ships made its effects felt across the ocean, and an attempt was made in the United States to create an efficient steam navy. With but a limited supply of funds for its creation, American architects were forced to study fully the necessities of the fleet before embarking on the new work. Since the foundation of the

navy it had been always one of the principles of American construction to build ships whose measurement exceeded those of similar types in Europe. Carrying out this principle in the development of the new fleet, there appeared in 1855 four steam frigates superior in every way to any European vessels of their class that had yet appeared. The importance of these vessels did not lie simply in their excess of measurements over European frigates, but in the combination of all those parts which go to make up the efficient fighting vessel. The Imperatrice Eugénie with her 3600 tons displacement had surpassed previous frigate developments, but had made no impression on other types of vessels. On the contrary, the appearance of the Minnesota, Wabash, Colorado, and Merrimac was the signal for the disappearance of the line-of-battle ship. The displacement of these ships was about 4700 tons, or 1100 tons in excess of the Eugénie. The battery was of the same *number* of guns as in the French ship, but exceeded by an inch in calibre that of any broadside afloat, the combination of numbers and weight giving these ships superiority even over three-deckers. Whilst the design of the Eugénie called for a speed of 12 knots, her coal supply was sufficient for but 1500 miles. The Americans, with a speed of $9\frac{1}{2}$ knots, carried coal for 2500 miles. The sail-surface of these ships was enormous, ranging as high as thirty times the area of the immersed midship section. In 1858 a fifth vessel was added to this type (Niagara), the displacement in this instance being carried to 5500 tons, speed 12 knots, with a coal capacity for steaming 2500 miles, full sail-power, and a battery in which calibre had been carried to the extreme limit of broadside fire (11 inches).

Whilst the French were engaged on their Eugénie type the English had laid down a type of 3000-ton frigates (Emerald class) which reached a speed of 13 knots. On the appearance of the Wabash in European waters, the English at once designed a type to surpass her, and completely overshot the mark in the Mersey and Orlando, in which displacement was carried to 5600 tons; but in the attempt to realize a speed of 13 knots, they gave the vessels proportions that were unfit for wooden construction. With their profusion of experiments, however, we find between 1857 and 1860 a succession of types ranging from 2500 to 4600 tons, the majority averaging about 3800 tons. In these ships may be seen the constant search to find the one combination that shall possess all the excellences. All of these vessels were thorough cruisers, and in no case except in the Mersey type do we find the experiment resulting in worthlessness; still, an examination of the frigates will

show the impossibility of giving a distinct classification to them. Beyond the Crimean war it has been already stated that the development of the line-of-battle ship had scarcely passed the experimental stage, and after 1857 the sudden increase in power of the frigate, combined with the introduction of the sea-going iron-clad, stopped almost entirely the development of this type, although their construction was carried on until 1860.

In France a new fleet programme was laid down in 1857, in which the heavy American and English frigates were entirely ignored, and whilst new frigates of the Eugénie type were built almost without change, the increase in vessels of this class was confined almost exclusively to lengthening and converting the old frigates of 2500 tons into steamers of 3000. Development of wooden ships was found only in the corvette class. The reason for this independent departure was, in all probability, due to the original start made by France in the development of the iron-clad frigate in this same year, combined with a dissatisfaction on the part of the French with the speed realized in the Wabash and Orlando.

In 1858 the United States Navy put forth a type of vessel new in every particular, and one whose value, although not immediately recognized, has by its development become the true standard for effective medium unarmored cruisers. The Hartford, Brooklyn, Richmond, and Pensacola combined all the advantages of both the second-class frigate and the sloop-of-war. With a displacement of 3000 tons, which placed them in a line with light frigates, their steam-power was fully developed, whilst steaming capacity and sail-power were kept at a maximum, and strength of battery combined, in the best manner, calibre and number of guns. In the civil war, which soon followed, no class of vessels proved itself of so much fighting value as this. These vessels formed a distinct class in the navy, and contemporaneously with them appeared a third and lighter class (Iroquois, Wyoming, Mohican, and Narragansett), with a displacement ranging from 1600 to 1900 tons.

In France this latter type had appeared in the navy at the same time, the Cosmao and Dupleix, with a displacement of 1800 tons, realizing a speed of nearly two knots greater (12 knots), whilst steaming capacity and sail-power were the same, and the battery was inferior in about the same proportion as the speed was superior.

In England the development of this class was an extension of the old steam-sloop, realizing in the Challenger and Barossa type a displacement of 2350 tons, with the disadvantages of excessive draught of water, lack of development of speed

and steaming capacity. No better evidence of the complete demoralization of architectural development in the United States can be found than in the movement made in 1872, in which the Hartford class, after having established thoroughly its great utility, was by the addition of a spar-deck reduced to the plane of the Challenger, with increased draught, reduced speed and steaming capacity, and in fact a reduction of all the qualities which had rendered it superior, notwithstanding the total disappearance of the type not only in the English but in all foreign navies.

During the Crimean war a great number of gun-boats, ranging between 500 and 800 tons displacement, had been hastily but well constructed, and the type was continued after the war until 1860 almost without change. The same types with but slight modifications were contemporaneously introduced in France, those of the French Navy, as a rule, possessing a superiority in speed of about one knot.

With the Immortalité frigate, the Challenger sloop, and the Britomart gun-boat, the development of wooden war-vessels ceased in England in 1859, giving place to composite and iron construction.

In 1860 a new range of types appeared in the French Navy, the prominent feature throughout being the extreme development of speed and steaming capacity, combined with medium sail-power and a minimum battery-power, although here the French introduced the rifled gun as an offset to the heavier calibres of American smooth-bores, the primitive type of the rifle leaving it inferior to the latter in power. In the first rate appears a development of the English Challenger class.

RATE.	Name.	Displacement.	Speed.	BATTERY.
		Tons.	Knots.	
First	Venus.....	2,700	12.7	XIV 6½-inch rifles, VIII 6-inch smooth.
Second	Decrés	1,770	12	II 6½-inch rifles, IV 5¾-inch rifles.
Third	Talisman...	1,300	12.4	II 6½-inch rifles, IV 4¾-inch rifles.
Gun-boat	Adonis	730	9.3	IV 4¾-inch rifles.

The corresponding new types of the United States Navy as they appeared in 1862, excluding the frigates, although the Franklin appeared after this date as the last of this type, were:

RATE.	Name.	Displacement.	Speed.	BATTERY.
		Tons.	Knots.	
Second.....	Hartford....	2,900	10.5	{ II 11-inch, XVIII 9-inch smooth, I 5¼-inch rifle.
	Shenandoah.	2,100	12	{ II 11-inch, VIII 9-inch smooth, I 5¼-inch rifle.
Third	Iroquois....	1,575	10	{ II 11-inch, IV 9-inch smooth, I 4½-inch rifle.
Gun-boat	Saco.....	900	9.5	IV 6½-inch smooth.

From these lists the aims of the constructors in France and the United States may be seen. In the former, displacement was kept at a medium whilst speed was developed to the extreme, the balance in battery-power being sought in the introduction of rifles. With the latter, displacement and battery-power were carried to the extreme, speed being sacrificed, although in this respect great attention was paid to retaining fine underwater lines and a maximum of sail-power.

From 1860 to 1873 an interregnum in the development of French wooden types occurs corresponding to the length of time intervening between the fleet programmes.

At the outbreak of the civil war, the Hartford, Shenandoah, and Iroquois types were being built upon slowly, with every prospect of completing a small but compact and efficient cruising fleet. Whilst, however, this fleet had been designed especially for ocean cruising, the unforeseen exigencies of this war demanded the immediate introduction of a type of light-draught gun-boats for river service, as well as an immediate increase in the numbers of vessels for blockade duty. During the first two years blockading and river vessels were extemporized from whatever material could be found in the merchant service. It was this war, however, which gave birth to the Saco type of gun-boats, these vessels being of a greater tonnage and better fitted for blockade duty on the open coast than the gun-boats of foreign types. Although the vessels of this type, hastily constructed and of poor material, were completely worn out in five or six years' service, the type was renewed and has remained in the service. Two types of river gun-boats, both of which passed out of existence with the war, demand attention from their great usefulness. The first of these was the ordinary river ferry-boat. These vessels, having a displacement of less than 300 tons and a draught of water of seven feet, possessed two valuable qualifications for river fighting. They were built to run either end foremost with equal facility,

their speed being moderate and manœuvring qualities excellent. Their decks, intended to carry heavy moving weights, needed no especial bracing to prepare them for heavy batteries. These ferry-boats, without undergoing any transformations except those made necessary for the proper accommodation of the crew and the manœuvring of the guns, carried successfully throughout the war heavier proportional batteries than any vessels afloat before or since. The type itself, enlarged and modified so as to permit the vessel to do cruising duty as well as river service, appeared in 1863 in what was known as the double-ender, a vessel standing between the gun-boat and the second rate, but not to be classed with the regular third-rate cruiser.

The total ruin of American commerce, brought about by the depredations of half a dozen Confederate cruisers, led to the introduction of four new types of ships, and in these types American constructors sought in general to realize the maximum of speed without reducing any of the other qualities.

The first of these (in point of rate) was designed entirely with a view to securing the highest possible speed and steaming capacity, all other qualities being made subordinate. The displacement of this type was between 4800 and 5000 tons, ranging about 300 tons higher than the frigates of 1855, and they were designed for a speed of 17 knots, with a steaming capacity of 5600 miles at 10 knots. The speed alone was realized. The ships themselves being built of white oak rotted almost before they could be launched; the frame was not of sufficient strength to resist the powerful working of the engines or the wear and tear of cruising, failing in this particular as the English frigates *Mersey* and *Orlando* had in 1858. The consumption of fuel was beyond the calculations, reducing the steaming power to less than 3500 miles.

The second type was that of a fast frigate, or more properly first-rate (*Piscataqua*), in which strength of battery and sail-power were raised to their old proportions with regard to the displacement. The displacement of this type was 4000 tons, battery 25 nine-inch smooth-bores, and speed 12 knots, with a steaming capacity of 3000 miles at 10 knots. These ships were also built of white oak and soon rotted, and their general unhandiness combined, with the great expense of keeping them in commission, caused the type to drop out of existence.

The third type (*Congress*), having a displacement of 3000 tons, came nearer to the requirements of a large fast ocean cruiser than either of the others, proving fast under steam or sail, handy, and carrying a well-proportioned battery. This type died out with the others in the general demoralization following the reduction of the fleet after the war.

The fourth type (Plymouth), having a displacement of 2400 tons, with a battery of 12 guns and a speed of 12 knots, was in reality a development of the Shenandoah class, having for an increase of 300 tons a gain in battery proportional, and a maximum of speed both under steam and sail without any increase of draught. Of the four types, this one alone, which was a development of the Shenandoah class, the latter being modified from the Hartford, was the only real step in advance; but even this type has passed from the active list at present.

Between 1865 and 1873 England was the only country in which real development was carried on. The French, keeping closely within the limits of their programme, were engaged in developing speed and testing subordinate modifications in the lower rates of their vessels. By this is meant such modifications as testing the value of the topgallant fore-castle, leading to its adoption in all rates; the suppression of the poop-cabin, the test of the long ram bow for furnishing additional buoyancy forward, the merits of double and single screw propulsion, etc.—particulars which were subordinate to the main architectural development. The United States Navy from 1865 to 1873 passed through a period of uninterrupted decadence. Millions were spent in the futile effort to patch up the fast-rotting fleet of white-oak ships that had been hastily constructed during the war, while not a single attempt was made to benefit by the rapid development of the English.

Between 1860 and 1866 English attention had been almost exclusively turned to the development of the iron-clad fleet; that of the unarmored fleet consisted almost entirely of experiments in composite and iron construction, bringing out no new types, but perfecting constructional development. In the latter year, however, directly following the appearance of the Wampanoag, the same course was followed as with the Wabash ten years before. Before the world had had time to form any judgment with regard to the real value of the type, the lines of the Inconstant were laid down and the ship was pushed rapidly to completion. In this case the development of iron construction saved England from the blunder committed in 1858 with the Orlando. It was the American vessel that had overshot the mark in measurements for wooden construction. The English turned out a seaworthy ship, but her real utility is questionable owing to her unhandiness and the expense of keeping her in service. The displacement of the Inconstant is 5800 tons, battery ten 9-inch and six 7-inch rifles, speed 16 knots, and steaming capacity 2160 miles at 10 knots. The Americans attained superior speed and

steaming capacity by a sacrifice of battery-power. The English attempted to realize all the qualities.

At the same time two other fast cruisers approaching the rate of the Congress were built (*Volage* and *Active*). Between 1870 and 1873 is seen the same search amongst dimensions to find the ones which will best satisfy the demands of speed, steaming capacity, and battery-power. The *Shah*, *Raleigh*, *Boadicea*, *Bacchante*, *Euryalus*, and *Rover*, ranging in displacement from 3500 to 6000 tons, overshooting the mark at first, and apparently best satisfied with dimensions falling between the *Piscataqua* and *Congress* types. All of these ships belong more properly to the *Piscataqua* than to the *Wampanoag* type; the latter appearing fully developed in the *Iris* and *Mercury*, in which, as in the *Wampanoag*, all is sacrificed to speed. The modifications in this case consist, first, in the steel construction, giving a strength of frame sufficient to withstand the engine-power; second, the reduction of dimensions, giving a displacement of 3700 tons; third, the increase in speed to 18 knots.

In France is found, on the programme of 1873, provision for first-rate fast cruisers; accepting the necessity for this development of the general frigate type, this country deliberates and studies the birth of the type in 1865 in the United States, its development for six years in England, and finally crowns the English modifications with what to-day must be regarded as the most perfect development of the *Piscataqua* and *Shah* type. The *Duquesne* and *Tourville* have a displacement of 5400 tons, speed of 17 knots, and steaming capacity of 5000 miles at 10 knots. In these ships France borrows the English constructional development of iron sheathed with wood, while by an excellent arrangement she secures a full battery-power with an almost perfect command.

Next in order of rate in England, but last in development, is what is known as the C class of corvettes. Built of steel, with a displacement of 2380 tons, they truly represent the last development of the type whose foundation was the *Hartford*, and this type is apparently as great a favorite in the English Navy as the *Hartford* in her day was in that of the United States. In France the second-rate of the programme of 1873 is a distinctly new type. The *Duguay-Trouin* in one respect is a departure from French custom, her dimensions being carried to the maximum for this rate, giving her a displacement of 3200 tons, which is an increase over her own immediate predecessors of 1200 tons. Her battery-power is if anything lighter than the proportional French average and below that of the English and American vessels of lighter displacement.

She is designed for a speed of 16 knots and a steaming capacity of 3500 miles at 10 knots. The main architectural peculiarity of this vessel is the arrangement for securing great command of fire. Her battery is all carried on the upper deck, whilst she has a clear flush main-deck; the opening of fore-and-aft fire by carrying the gun-platforms beyond the upper-deck rail is also a modification. Contemporaneously with the Duguay-Trouin the Americans introduced a new type which comes nearer a modification of the Raleigh than any other class, although it springs directly from the attempted modification of the Hartford class referred to above by which spar-decks were added to them. The present Hartford, with her spar and main decks, and the development of the type in the Trenton show two ships wherein is well exemplified the absurdity of, as it were, putting new wine into old bottles. The Trenton has a displacement of 3900 tons, a battery of eleven 8-inch rifles, and a speed of 13 knots, with a steaming capacity of 3500 miles at 10 knots. In this ship, as in the Trouin, the dimensions of the second rate are carried to an extreme, although in this case the Americans hold fast to the idea of combining moderate speed with a maximum of battery-power and general cruising qualities. The Hartford, however, having proved herself possessed of all the excellences of her day, and these excellences having been secured by a wise distribution of architectural elements, was sacrificed to the crude development of a new type by the addition of a new deck. Although these two ships belong to the same type and rate, no comparison can be instituted between them, and at the very time that the English perfect the Hartford type in the C class of corvettes a blunder of the Americans disrates the original.

Below the C class in England appeared the Opal class of 1900 tons, a modification of the earlier Blanche type corresponding and following close after the American Plymouth type. At the same time a corresponding type appeared in France and the United States. In the former the Rigault de Genouilly has a displacement of 1640 tons, an increase of 400 tons over her immediate predecessors, a battery of eight 5½-inch guns, and a speed of 15 knots, with a steaming capacity of 4000 miles at 10 knots. In America the Marion has a displacement of 1900 tons, a battery of one 8-inch and seven 5½-inch guns, and a speed of 12 knots, with a steaming capacity of 2500 miles at 10 knots. The French in this class show the same difference in qualities from the English and American types that appeared twenty years before.

The English development closes with the gun-boats whose types come more directly from those commenced during the

Crimean war. The displacement of these vessels ranges from 400 to 900 tons, with a diversity that scarcely admits of a distinct classification. The American gun-boats are reductions of the Iroquois class of corvettes, exceeding the English in average displacement, or rather showing no types below 500 tons. The French gun-boats are more closely allied to English than to American types, although there is but little difference between the three, the English showing greater diversity, the Americans greater measurements, and the French greater precision of rating.

Chart of Architectural Development.—Unarmored Vessels.

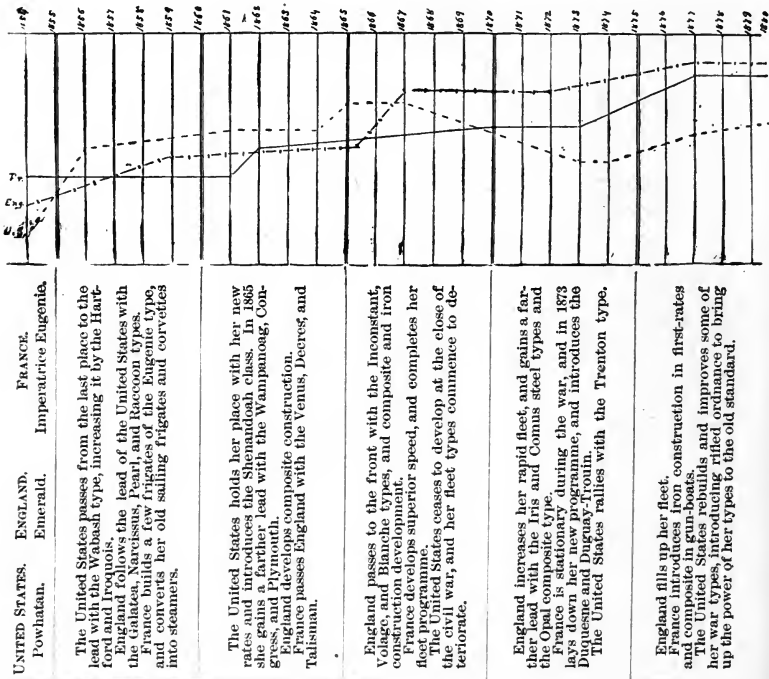

CONSTRUCTIONAL DEVELOPMENT.

Previous to 1857 wood construction was universal in the building of war-vessels. About this date England introduced iron frames in her first armored vessels, passing rapidly to the full development of iron construction in armored ships, composite construction in the medium and light classes of unarmored vessels, and iron or steel sheathed with wood in the first and second unarmored rates. By 1867 the old wood construction had been entirely discarded.

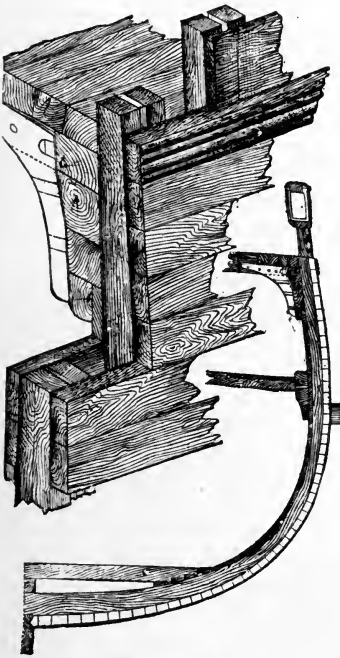

French Corvette La Clocheterie
(Wooden System.)

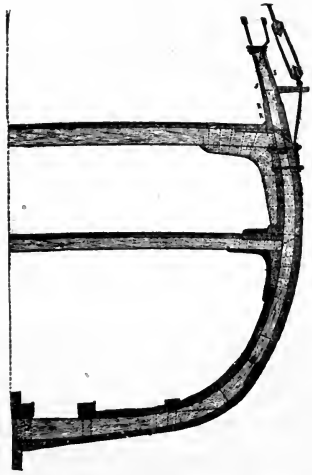

United States Corvette Plymouth.
(Wooden System.)

In France the wooden construction was almost exclusively used until the development of the programme of 1873. Iron was then introduced in the armored hulls, iron sheathed with wood in the first and second rate unarmored ships, and composite construction in the gun-boats of less than 700 tons, leaving the light second-rates and the third-rates to the old wood construction.

In the United States the wood construction is still invariably followed. There are no composite vessels in the navy, nor has any attempt been made to build one. There are two or three iron vessels of 1000 tons displacement, built during the period of greatest demoralization, and on account of political pressure brought to bear in the interest of iron merchant-ship building. These vessels can scarcely be pointed at with pride, since, throughout the naval world, pure iron construction is found only in transports and troop-ships. In England, where iron ship-building had its birth and development, constructors have never proposed this very excellent type of *merchant-ship* construction for war-vessels.

Wooden Construction.

The keel in the wooden construction is sided to a certain proportion to the beam of the vessel, the pieces composing it being generally connected by a plain scarf, the stem carrying the form up forward being hook-scarfed to the forward end of the keel and supported by the timbers of the deadwood and apron, forming a solid mass at the fore-foot. The stern boundary is carried up in the main stern-post, which seats with two tenons on the after-end of the keel, being supplemented in some vessels by a rudder-post, but generally in the larger classes of vessels the latter gives way to the equipoise rudder. The angle of the stern-post and keel is made up into a solid supporting mass by the after-deadwood. The junction of stern-post and keel is further strengthened by bronze castings bolted on each side. The keel is rabbeted each side to receive the garboard strake of planking, and the stern-post and apron prolong the rabbet at either end for the hooding-ends of the outside planking. The floor-timbers cross the keel, giving an alternate long and short arm on either side, the frames being carried up by futtocks and top-timbers shifting butts. Over the floor-timbers in the plane of the keel a heavy keelson is laid with, generally, sister-keelsons on each side, the system of keel and keelson forming the rigid back-bone of the ship.

The longitudinal supports of the ship are the boiler-keelsons, parallel to the main-keelson and forming the supports to the boilers; the diagonal bracing, composed of iron ribbons of about three fourths of an inch in thickness, crossing each other at an angle of 45°, and forming a complete lattice-work for the ship extending from the spar-deck to the turn of the bilge. These braces are generally worked on the inner side of the frames, but in certain cases they have been worked on the outside or on both sides. The inner planking, formed of the

thick strakes, bilge-strakes, and ceiling ; the deck-clamps, ranges of heavy plank for the support of the ends of the beams ; water-ways, covering the beam-ends and corresponding to the deck-clamps underneath ; and the outside planking.

The transverse supports are the beams with their connecting systems of knees and carlings, the breast-hooks and transoms, and finally the decks themselves, which furnish both longitudinal and transverse support. Of late years it has been the custom to make the beams, knees, breast-hooks, and transoms of iron, and it is a very general idea amongst those who have not paid especial attention to the subject that this modification, taken in conjunction with the introduction of diagonal braces, constitutes composite construction, which is by no means the case.

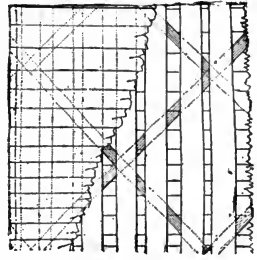

Diagonal Braces.

In the wooden construction the American and the English systems are very closely allied, whilst the French differs from both in many details. These differences are, however, in the detail work, a description of which would be scarcely warranted in the general summarizing of a system.

The outside planking is made up of a series of strakes differing in thickness of plank in accordance with the points at which the greatest strains are brought by the motions of the vessel. Next the keel on each side, and tending to give it thorough support, are ranges of plank firmly secured in the rabbet of the keel and thicker than the planking in general, called the garboard strakes. Outside of the gun-deck beams is another range of heavy planking called the main wales, and in two and three decked vessels other strakes called middle wales are worked abreast the other beams. In the same way a great longitudinal strengthening is gained in the deck-planking by the outer range of planks next to the water-ways, called the thick strakes.

It is considered that all these points are generally understood, and they are simply referred to on account of the necessity of bearing them in mind in following the developments.

Diagonal Construction.

This system of construction is found only in the English royal yachts and in their heavy wooden steam and sailing launches, but it is the opinion of an eminent English naval architect that had it not been for the very general introduction of iron in ship-building it would probably have taken precedence

over the ordinary wooden construction. Its only objectionable feature is its expensiveness, while it is much superior in point of lightness and structural strength. Whilst in the ordinary wooden construction the weight of hull ranges between 46 and 54 per cent of the displacement, it is reduced in the diagonal system to between 32 and 40 per cent.

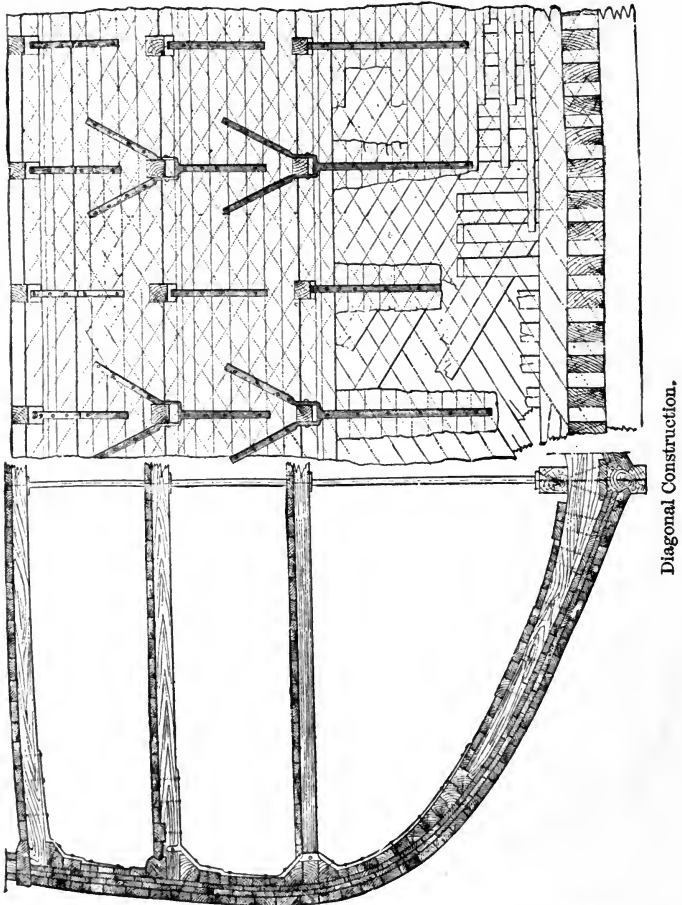

In this system the keel, keelsons, stem and stern posts, and floor-timbers are similar to the ordinary construction. The heavy frames, however, stop with the floor-timbers, and there is no diagonal iron framework. The outer and inner planking of the ship are the same as in the old construction except that the thick strakes of outer planking forming the wales are done away with, retaining only the heavy garboard-

strakes. In place of the futtocks and top-timbers of the old construction a double course of diagonal planking is introduced. That part of the inner planking which covers the floor-timbers is of the ordinary thickness, whilst beyond the timber-heads the planking is increased in thickness to give a smooth turn to the bilge ceiling. These four or five strakes are rabbeted into each other and into the timber-heads. The clamps and water-ways are as in the old type. In order to give transverse strength to this system, the knees are constructed in a peculiar manner. The lower leg of the orlop-deck hanging knee is carried down beyond the head of the floor-timber. Every other knee is forked, giving a housing to the beam-end, the two legs following the curve of the clamps and water-ways and rising with a spread of half the height between decks and beyond the foot of the hanging knee over it.

This system of construction has found great favor in England in the construction of yachts, and it has been very successfully applied to sailing merchant-ships and steamers.

Composite Construction.

The object of this construction is to combine, as far as possible, all the advantages of the wooden and the iron ship. There are three main systems of English types ranging from a close approximation to the wooden construction to that of the iron sheathed with wood, which latter forms the connection between composite and iron construction. In McLain's system, which is the closest approximation to the wood construc-

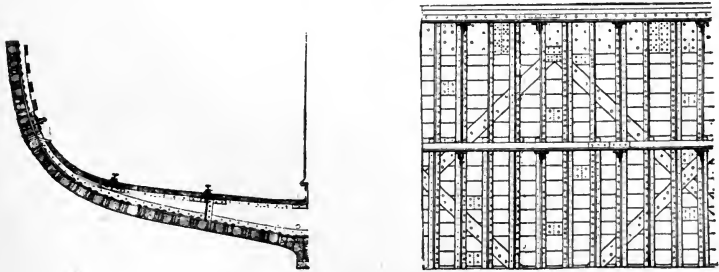

Jordan's Composite Construction.

tion, the keel, stem and stern posts, frame, and outer planking are of wood. The ceiling or inner planking, however, is of iron, forming a complete iron inner skin; the beams, knees, stringers, keelsons, transoms, and breast-hooks being also of iron. The wooden frames are of a smaller scantling than in the wooden system, being supplemented by angle-iron frames, by means of which the iron skin is secured to them. The

outer planking bolts directly to the wooden frames, being kept entirely clear of the iron inner hull. In Jordan's system the frames are entirely of iron, inner and outer skins being of wood, whilst the keelsons, stringers, and transverse supports are of iron. In Scott's system the frames are made of T-iron instead of angle-iron as in Jordan's system, and a modification is introduced by which the frames are spaced much farther apart. Between the frames oak or teak chocks are fitted,



Scott's Composite Construction.



McLain's Composite Construction.

bolted to the frames and calked throughout, thus forming a complete water-tight course. These are the main types as represented in England. In Russia is found another system which, doing away with diagonal braces, which it must be remembered are used with all the systems just described, makes use of the McLain system in connection with Mr. Scott Russell's method of longitudinal strengthening. In this, the keel, stem and stern posts, and outer planking are of wood,



Russian System.

whilst the frame is of iron with an iron skin outside of it, which in general terms would class the type with that of iron ships sheathed with wood. To the outside of this iron skin Z-iron stringers are bolted, the space between them being filled up by chocks to form a complete wooden sheathing. These chocks are made shorter than the spaces, and are wedged in their seats. Outside of this sheathing is run the wooden outer planking in the ordinary way. It will be seen by the descriptions

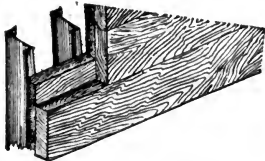

French Gun-boat Crocodile.
(Composite.)

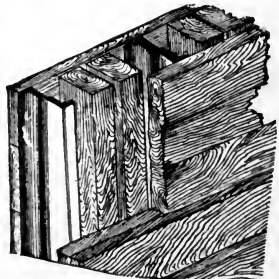

French Transport Annamite.
(Composite.)

following that this system can scarcely be classed as a true composite.

The French system as applied in their light gun-boats has the same wooden outer skin, with the ordinary iron frame. The outer planking is double, gaining great longitudinal strength by breaking seams. There is no diagonal bracing. This system of outer planking is the one used in the English Navy. In the French transports of the Annamite class a system of alternate framing is followed, with wooden ceiling and double outside planking. In these vessels additional longitudinal strength is gained by the use of heavy iron box-stringers in place of the ordinary water-ways.

Iron Construction.

In tracing the development of iron construction it is necessary to pass from the consideration of unarmored vessels to the armored types, as the pure iron construction is limited almost exclusively to these vessels. The advantages of iron over wood may be summed up as being, 1st, lightness combined with strength; 2d, durability when properly treated; 3d, ease and cheapness of construction and repair; 4th, safety when properly constructed and subdivided. Its disadvantages are: (1) easy penetration of the bottom by rocks or by other pointed substances; (2) fouling of the bottom and consequent loss of speed; (3) the immense holes made, not only by taking out solid pieces, but, what is worse, the long rents or tears made by a penetrating shot through the thin side-plates and frames. Fast cruisers cannot be built of iron alone on account of the fouling, and the smaller the ship the greater the harm from this cause. War-vessels of any kind are excluded from this construction on account of the vulnerability of the sides, combined with the impossibility to stop a shot-hole which is starred with long rents. In the heavy iron-clad, however, the third disadvantage is done away with by the application of armor. The second is partially overcome by the surplus engine-power, and the first is neutralized by the double bottom, wing passages and compartments which the large roomy hull allows to be introduced.

The Brazilian iron-clad corvette Brazil, although built as late as 1866, is a good example of the primitive iron construction as applied to vessels of war. The keel of this vessel is what is known as the solid-bar type, the plates forming the garboard-strakes turning down on each side of it. The frames, made of upper and lower angle-irons strengthened from the amidship line to the turn of the bilge by a deep web, abut against an interior keel formed of a single plate surmounted by a flat plate-keelson, the frames, keels, and keelson being

thoroughly bound together by angle-iron. The stem is scarfed into the keel, rising as a continuation of it and being rabbeted for the reception of the bow-plates. The main longitudinal strengthening consists in an iron bulkhead rising from the bilge to the under side of the main-deck and running fore and aft, forming water-tight wing passages. Just outside of the edges of the plate-keelson is what is called an intercostal longitudinal frame, consisting of short plates between the webs of the frames and secured to them by angle-irons; these frames run fore and aft. In addition to these longitudinal supports, a

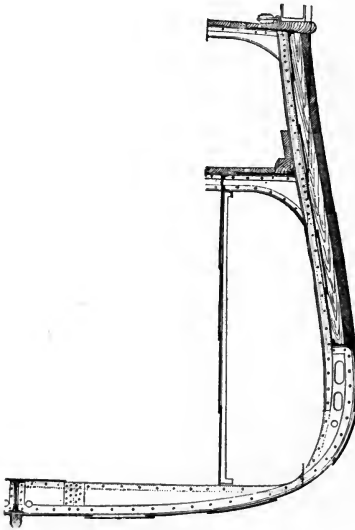

Brazil.

wide stringer-plate is carried along underneath the water-ways of both decks. In the formation of the armor-shelf, the exterior angle-irons of the frames, turned back along the edge of the web, form the shelf, while the interior angle-irons are carried up unbroken to the plank-sheer. The plating is the system generally applied of every other plate lapping on both edges.

In the Warrior the solid-bar keel gives way to the plate-keel, which in this case is double, the garboard-strakes butting against the edges of the internal plate, while the external one laps well over the joint. The continuous internal keel is found in this ship similar to the Brazil, secured by angle-irons to the inner keel-plate and the broad plate-keelson. The lower angle-irons in this case are continuous, while the upper ones

are in short lengths, permitting the upper angle-irons of the *frame* to pass across and form a continuous length from plank-sheer to plank-sheer. The web of the frame is here shown increased in depth to a maximum, being lightened as far as possible by circular sections cut out. The assemblage of a frame consists of the continuous inner angle-irons, one on each side of a narrow strip to which the deep web-pieces are bolted, and the lower angle-irons bounding the webs. In the Warrior will be noticed six longitudinal frames similar to the continuous

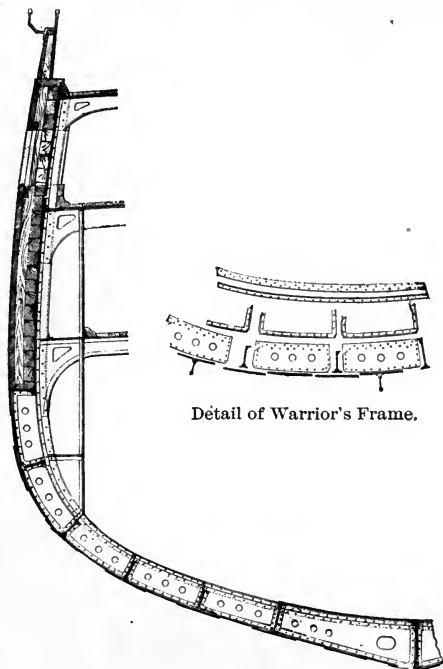

Detail of Warrior's Frame.

Warrior.

inner keel, and it will be noticed that the third of these frames, forming the seat of the wing-passage bulkhead, and the sixth, running along the outer edge of the floor-plates, project beyond the angle-irons of the transverse frame, being slotted to permit these angle-irons to pass them. The wing-passage bulkhead forms another longitudinal support, extending fore and aft from the turn of the bilge to the lower side of the main-deck. The armor shelf-plate in this instance consists simply of a broad plate bent at right angles and secured by angle-irons

to the inner plating. This is a noticeable feature, as the extreme strain on the plate in the sharp bend is a plane of weakness.

The Bellerophon shows the same arrangement of keel and keelson with the addition of wooden bilge-keels secured lightly to the bottom plates by angle-irons. The framing of this ship, however, is of the type known as the bracket-plate system. The features of this system are the adoption of a double bottom and of angle-irons connected by bracket-plates instead of by solid forged iron-work. The web of the frame in this instance is much deeper, giving a large space between the outer plating

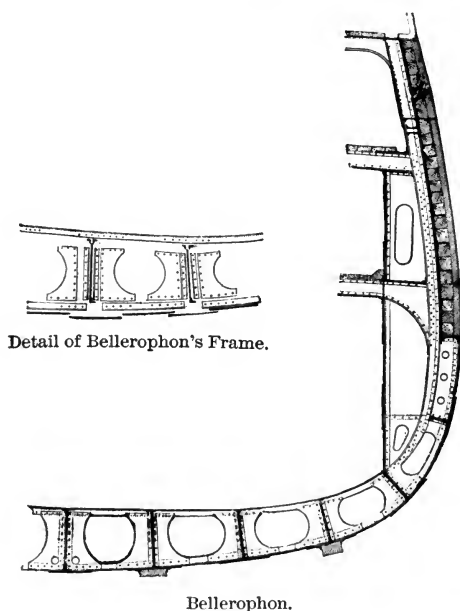

Bellerophon.

and the bottom formed by plating the floor edge of the transverse frames. In the Warrior it will be noticed this plating only extended to the third longitudinal on each side, while in the Bellerophon it reaches to the wing-passage bulkhead. The transverse inner angle-iron is continuous from bulwark to bulwark, the outer one being in short lengths to allow continuous longitudinals. The upper angle-irons of the longitudinal frames notch down over the transverse frames, while the lower ones are continuous. The spaces between the bracket-frames lighten the assemblage a great deal, while the longitudinals, being of continuous plate like the inner keel, are lightened by

having holes cut in them. In this manner large water-tight compartments are secured; for the inner keel, the third longitudinal, and the wing-passage bulkhead longitudinal are solid. The web just underneath the armor-shelf is of the old-style solid plate, to give better support than would be gained by bracket-plates. The double-bottom arrangement continues throughout two thirds of the length of the ship, the frames outside of this being reduced in dimensions. The armor-shelf of the *Warrior* proving a weak construction, that of the *Bellerophon* was better worked. The outer angle was formed by an angle-iron bolted to the vertical outside plating, and to a flat plate forming the armor-seat, the iron being on the inside of each plate. This left an open joint between the lower edge of the plating and the upper edge of the side-plate, but the joint is one easily calked.

In the *Hercules* the bracket-plate system is quite similar, and additional strengthening was put in by partially filling the wing-spaces with a strake of heavy teak backing. Two box-

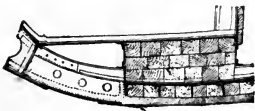

Filled Wing-Passage of Hercules.

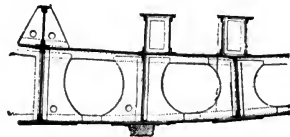

Floor of Hercules.

keelsons were also run on each side of the main keelson, and the main keelson itself was strengthened by being carried up above the floor and braced by brackets on each side. The armor-shelf in this instance was also slightly modified.

In the *Invincible* the wing-passage and its bulkhead is done away with, and in place of it the web of the transverse frame is deepened considerably, carrying the double-bottom arrangement up to the armor-shelf; and whilst retaining a good depth as security against the outer skin being broken by ramming, much space is gained in the hold.

These ships, being constructed for ramming, require a firmly braced stem. The stem itself is a solid forging, and attaches to the flat keel by a plain scarf, the outer keel-plate being carried some distance farther along the turn of the fore-foot than the inner one. The whole length of the stem is deeply rabbeted to receive the forward ends of the side-plates and armor, which all house in it. For a distance of forty or forty-five feet from the bow the bottom plates are doubled to give additional stiffness, each plate housing in a separate

rabbet. The rear side of the stem is cut square, the breast-hooks seating fairly on it.

Stern-posts are now invariably made in single solid forgings, and are plain scarfed to the keel as with the stem. Compartment bulkheads form an element of great transverse strength. There is no fixed rule for their application in war-vessels, but the usual number is seven. Of these, one is placed well forward, called the collision bulkhead, another is far enough aft to just enclose the screw-shaft stuffing-box, two others are respectively forward of the boilers and abaft the engines, and the others divide the remaining space as is best suited. Above the water-line, doors of a sufficient size to render free passage are worked in the bulkheads and are on hinges having clamps by which they may be screwed up water-tight. Below the water-line the doors slide either horizontally or vertically, being worked by gearing on the main-deck. The wing-passages are provided with small sliding doors generally kept closed. The compartments of the double bottom are connected by sluice-valves worked from the main-deck.

These points constitute the main peculiarities of iron ship-building as it is at present carried on. There are constant modifications made in details, many of which are of the greatest importance, but a description of them would be out of place except in a work on iron ship-construction.

Iron Sheathed with Wood.

It has been stated that in no navy (except that of the United States) are there to be found iron ships of the pure construction. When iron ship-building was first introduced in England, two iron sloops were laid down and experiments were carried on with targets representing their sides, to find out the effect of shot upon them. The frames of these vessels were spaced only one foot apart, and it was found that a very serious amount of splintering took place when a shot penetrated. It was also found that for thicknesses beyond half an inch the projectile was broken to pieces on contact. This advantage for iron was, however, soon counterbalanced by the rapid increase of calibre, change to rifled guns and high velocities, and the introduction of steel and chilled projectiles. The great advantages offered by iron construction, however, rendered its introduction an absolute necessity when it became a question of speed. The rapid fouling of bottoms, with its consequent loss of speed, could only be overcome by coppering, and this necessity introduced another and far more serious difficulty, that of galvanic action. The introduction of the sys-

tem of sheathing iron with wood is due directly to Mr. Grantham, an English builder. The main principles laid down by him were to have widely spaced transverse frames, and on the exterior of the iron skin to work a system of angle-irons which should in themselves bring up the strength of the hull to the standard, making up for the loss by wide spacing. The iron skin having been covered with pitch, a wooden filling was introduced between the angle-irons, wedged solid so as to form a complete wooden casing. Over this was placed a layer of tarred paper, and then the sheathing proper of the ship was fastened by brass screw-bolts to the wooden filling, completely insulating the iron hull. This sheathing could then be coppered. These exterior angle-iron frames, being worked as a support to the inner ones, take, as a rule, an opposite direction. Thus if the main inner frames are transverse, the exterior ones are longitudinal, and vice versa. Grantham's method is in reality the one shown in the description of the Russian composite system.

The English Admiralty method is somewhat different. Here the sheathing is in two thicknesses, the inner course being tap-bolted to the iron skin, the bolt-heads being sunk well into the planks and covered with pitch. The outer course shifts seams and butts with the inner one and is secured with brass screw-bolts. Over this course comes the copper. The Admiralty system is the one followed in France in the construction of the first and second rate fast cruisers. The difficulties of insulation are not yet solved by any means. Could the sheathing be absolutely excluded from moisture the system would be perfect, but as yet no means have been devised by which the wood can be prevented from becoming wet and thus serving the part of the porous jar in a voltaic cell.

In examining and discussing different systems of construction it is necessary to always keep in mind the great distinctions between composite, iron, and iron sheathed with wood. Those who cry down the wooden construction, in view of the rapid deterioration of the American unarmored fleet, must bear in mind that this fleet was constructed of the worst possible material. In discussing the advantages of the composite system, those of the diagonal system must not be lost sight of. Above all, it must be remembered that the disadvantages of the pure iron construction, as evidenced by English and French target experiments, have never been overcome. The iron and steel sheathed with wood is an amelioration, but as yet it is by no means a satisfactory one. Although England has totally discarded the wood construction, it must be remembered that France holds her own with but a partial introduction of iron

and composite in her highest and lowest rates. The subject of constructional development is still in its experimental stage, and to those nations who, unlike Great Britain, cannot depend upon legislative support and sympathy, nothing is more dangerous to the healthy development of an efficient unarmored fleet than a hasty adoption of a new constructional type.

ARMORED VESSELS.

ARCHITECTURAL DEVELOPMENT.

It would be useless to attempt to assemble in chronological order the many propositions that have been submitted to or even entertained by different maritime governments looking towards the building of armored vessels. The first serious attempt made and effectually carried out was by France in 1855, when there were built five floating batteries carrying an armor of five inches, which, although almost totally unmanageable from their bad lines and realizing a speed of but four knots, went into action on the 17th of October in that year and silenced the batteries of Kinburn.

These vessels taught nothing with regard to architectural development, but at the instance of France the English Government built nearly at the same time some vessels quite similar, and the attention which this movement caused led to a consideration of the suggestions of Captain Coles, who, in the same year, sent into action the little cupola vessel *Lady Nancy*.

Had it not been for the dire necessity for an armored vessel to hold the *Merrimac* in check, Ericsson would not have won for the United States the credit of introducing the monitor type of vessel. Whilst he was designing the lines and arrangements of the *Monitor*, Coles was engaged in almost precisely the same work for the Danish Government, designing the *Rolf Krake*.

From the successful work of the French floating batteries that government passed at a stride to the *Gloire*, laid down in 1858. Scarcely was this vessel's frame up before the keel of the *Warrior* was laid in England. In designing these two ships the honors of development are divided between the countries. England introduced iron ship-construction, France combined thickness and disposition of armor as well as dimensions of vessels which required the least change as development progressed. Before the end of 1862 all Europe had been aroused to the new marine development. France and England already possessed iron-clad fleets, whilst Spain, Italy, Austria, Denmark, Russia, Holland, and Sweden were ordering ships wherever they could be obtained. In the United

States a powerful fleet of monitors and armored river gun-boats was being rapidly formed, whilst to this country the eyes of the world were turned for the actual warfare tests of the new idea.

In England the development of the broadside sea-going iron-clad extends from 1858 to 1867. Commencing with the *Warrior*, there is a gradual increase in dimensions until the maximum of unwieldiness is reached in the *Minotaur*, the false development ceasing at her and falling back in the *Bellerophon* and *Lord Warden*, the last of the pure broadside type, to nearly the dimensions laid down by the French at the commencement of their work. In disposition of armor the English departed in the same manner from true development. Commencing with simply an armored battery in the *Warrior*, altering to a fully armored main-deck in the *Valiant*, changing again in the *Achilles* to an armored water-line and battery, and ending with a full water-line and main-deck armor in the *Minotaur* and *Bellerophon*—the system adopted by France at the start. During this period Coles's turret-ship development commenced with two different types of ships—a harbor-defence type, represented by the old line-of-battle ship *Royal Sovereign*, which was cut down, armored, and provided with revolving turrets mounted on a low flush deck, and the *Rolf Krake*, *Scorpion*, and *Wyvern*, constructed for foreign governments, and intended as low-freeboard sea-going vessels.

In France the lifetime of the pure broadside type was about the same as in England. Commencing with the *Gloire*, a tentative development of iron construction was made in the *Couronne*, but was not followed up. Remaining satisfied with the *Gloire* type as it was perfected in the *Flandre*, the French built up a homogeneous and effective fleet, making but one false step in the development. This was in the attempt to carry height and weight of battery to a maximum by introducing a two-decked frigate. In the *Magenta* and *Solferino* the armor of the upper gun-deck was confined to the battery, leaving the ends exposed as in the *Warrior*, but with far more injurious consequences; for the upper works in these ships being of wood were open to the ravages of fire caused by shell and hot shot, which would have inevitably put these ships *hors de combat*. The turret-ship development was also commenced at this period with the ram *Taureau*, an amplification of Coles' *Lady Nancy*; passing from thence to the *Cerbère* type, which was closely allied to the American monitors. In the private ship-yards of France, Germany had commenced an independent type with the *Prinz Adalbert*, a false design which was repeated but once, in the Confederate ram

Stonewall. In comparing the developments of France and England, there is one novel feature worthy of remark. France, ignoring iron construction, made no attempt to convert her wooden line-of-battle ships into armored vessels. England, throwing wood construction out entirely as unfit for application, converted a number of her wooden vessels into armored ones.

In the United States, attention was turned almost entirely to the development of the monitor type, passing from the single to the double turreted class, and overstepping the limit in the three-turreted converted ship *Roanoke*. The Confederates having designed an independent armored battery-ship (*Merrimac* type), the Federals developed it in the *New Ironsides*, carrying it to the end in the *Dunderberg*.

Spain, Austria, and Italy adopted the French development of the broadside ship, the latter country making a false step in the *Affondatore*, which belonged to the *Rolf Krake* type. The northern nations introduced the American development almost unchanged.

In 1867 England struck the death-blow to the pure broadside ship by the design of the belt and box ship *Enterprise*, passing rapidly and in a true line to the *Pallas*, *Penelope*, *Hercules*, *Sultan*, and ending with the *Audacious*. During this period the faulty development of Coles's low-freeboard sea-going turret system culminated in the *Captain*, with whose loss the inventor perished. His work was not lost, however, for in the *Monarch* appears the true development of his system. During this period also the English, taking the American monitor type in connection with Coles's turret, advanced the combination in the *Rupert*, *Cerberus*, *Glatton*, and *Fury* (*Devastation*).

In France the broadside type was modified by introducing the short main-deck battery, supplemented by the spar-deck barbette turrets in the *Belliqueuse*, carried forward in the *Alma* and culminating in the *Ocean* and *Richelieu*.

In the United States, iron-clad development had entirely ceased. In Germany the *König Wilhelm* represented the full development of the English *Enterprise*, and the *Friedrich Carl* entered her fleet as the model of the second-rate armored cruiser belonging to the *Alma* type. Russia failed in an attempt to advance the *New Ironsides* type in the cruising iron-clad *Perwenee*. Holland, with the *Buffel*, introduced a new type of high-freeboard monitor, and Turkey appeared developing a fleet of the *Hercules* type.

Since 1871 the English have in their sea-going frigates mainly developed individual ships of different types—the *Alexandria*, *Temeraire*, *Nelson*, and *Shannon*. Their turreted

ships have advanced from the Devastation to the Dreadnought and Inflexible, and with these ships the English have for a time rested.

In France development was stopped for a time by the war, but recommenced in 1875, when the Alma type was perfected in the Victorieuse, and the Redoubtable and Duperré commenced a new departure. Their coast-defence vessels were also remodelled, following closely the ideas expressed in the Glatton, improving on her in the Tonnerre type.

In Italy independent action appears in the new cruising types Venezia and Palestro, and her architects rightly claim half the honor of the last development of turreted vessels. Whether to Italy or to England belongs exclusively the Duilio and Inflexible type is a question that probably will never be satisfactorily answered.

Austria develops independently the Custoza and the Tegetthoff.

Russia makes a false development in the Popoffkas, and a true one in the Duke of Edinburgh.

Germany carries the Monarch development to its highest point in the Preussen, and the Redoubtable development in the Kaiser.

Chili, with the help of England, produces a new and true type in the Almirante Cochrane, and Japan and Portugal each appear with a well-designed reduction of the Redoubtable in the Foo Soo and the Vasco da Gama.

In this rush of development of twenty years it is true that all fleets have been immeasurably strengthened, but it has been at a cost far beyond what the result would warrant. It is only within the past five years that the development of iron-clad architecture can be said to have taken any steady course. As yet the full effects of this forced and feverish course can scarcely be realized; but as fleets grow now slowly and steadily, those nations who have waited a little and profited by the true developments of the more hasty ones will be in a far better position to meet the sudden exigencies of war than those who have counted on numbers of vessels and gross tonnage displacement as a true criterion of naval strength. From the number of cautious nations the United States must be excluded, since in this country the blow given to the development of private ship-building by the civil war and to the development of naval architecture by political intrigue and interference has resulted in the nearly complete destruction of the science itself.

Nothing is more common amongst naval people than speculations and arguments with regard to the true methods of de-

veloping a fleet, and it is generally taken for granted amongst those who give the subject but a superficial study that, since the designs that have been created are almost countless in their variety, and that amongst those nations that have attempted an independent development there is not one that does not count as many failures as successes, the matter of design is one of pure guess-work, not stopping to think that, as a rule, the designers themselves are men of the highest abilities, and that with a ship, as with everything else, there are certain limiting circumstances that the nature of the vessel itself forbids violating.

In this respect a comparison of the proportions of the different elements of vessels of varying types affords a useful lesson.

RATIOS OF THE PRINCIPAL ELEMENTS OF IRON-CLAD VESSELS TO THEIR DISPLACEMENT.

First-rate, Sea-going, Full-rigged Frigates.

DISPLACEMENT RANGING FROM 10,500 TO 5400 TONS.

NAMES.		Hull.	Armor.	Hull and Armor.	Ordnance.	Engines and Boilers.	Coal.	Spars, Crew, and Supplies.
French.	Gloire472	.144	.616	.066	.114	.116	.088
	Magenta474	.161	.635	.073	.107	.107	.078
	Provence441	.163	.604	.065	.134	.107	.090
	Marengo463	.180	.643	.063	.111	.078	.085
	Richelieu476	.195	.671	.067	.095	.085	.082
	Devastation389	.204	.683	.061	.118	.064	.074
Austrian.	Kaiser481	.147	.628	.055	.113	.083	.121
	Tegetthoff342	.289	.631	.051	.145	.087	.086
German.	König Wilhelm401	.216	.617	.066	.121	.111	.085
English.	Warrior518	.149	.667	.059	.101	.098	.075
	Achilles504	.183	.687	.048	.107	.072	.086
	Minotaur493	.194	.687	.047	.101	.072	.093
	Bellerophon483	.171	.654	.054	.118	.085	.089
	Sultan428	.209	.637	.062	.133	.080	.088
	Hercules431	.199	.630	.065	.138	.090	.077
	Audacious437	.221	.658	.055	.117	.085	.085
	Alexandra405	.246	.651	.072	.141	.053	.083
Temeraire404	.226	.630	.058	.158	.060	.096	

Second-rate, Sea-going, Full-rigged Frigates.

DISPLACEMENT RANGING BETWEEN 5150 AND 2950 TONS.

NAMES.		Hull.	Armor.	Hull and Ar- mor.	Ordnance.	Engines and Boilers.	Coal.	Spars, Crew, and Supplies.
French.	Alma519	.234	.753	.043	.107	.062	.035
	Victorieuse.....	.475	.172	.647	.075	.096	.068	.114
Eng- lish.	Pallas488	.153	.641	.038	.162	.074	.085
	Shannon.....655	.071
Ger- man.	Hansa416	.194	.610	.069	.157	.067	.097
Rus- sian.	Duke of Edinburgh.....	.379	.112	.491	.033	.197	.215	.064
Chil- ian.	Almirante Cochrane....073073
Aus- trian.	Drache.....	.526	.133	.659	.041	.086	.089	.125

Turreted Sea-going Iron-clads.

DISPLACEMENT RANGING BETWEEN 11,550 AND 8400 TONS.

Devastation301	.341	.642	.054	.117	.146	.041
Dreadnought.....	.342	.301	.643	.048	.131	.137	.041
Inflexible.....	.327	.362	.689	.070	.117	.103	.021
Duilio341	.315	.656	.053	.117	.108	.066
Peter the Great.....	.366051	.145	.092
Monarch.....	.433	.217	.650	.041	.133	.072	.104

Turreted Coast-defence Iron-clads.

DISPLACEMENT RANGING BETWEEN 5550 AND 2550 TONS.

Cerberus428	.309	.797	.059	.077	.036	.031
Hotspur430	.309	.639	.030	.133	.069	.029
Glatton.....	.320	.352	.672	.068	.114	.112	.034
Cyclops.....	.411	.331	.742	.068	.076	.082	.032
Javary288	.373	.661	.068	.106	.051	.114
Popoff.....	.291	.384	.675	.078	.150	.047	.050
Onondaga624	.117	.741	.059	.102	.068	.130
Tonnerre359	.371	.730	.036	.118	.052	.064

Although these tables are too limited to permit of a just appreciation of the development of iron-clad architecture, much profit may be derived from them. For example: it is known that the French have been slow in adopting iron hulls, and at the first glance many are inclined to sneer at their backwardness, but an inspection of the table will show that their caution was well founded. In weight of hull they never passed 48 per cent, while the English with their iron construction did not reach that point as a *minimum* until the Hercules was designed. Whilst, however, the French had reached the lowest possible limits with wood (between 44 and 48 per cent), the English by constant improvement steadily reduced the weight of their iron hulls from 52 per cent in the Warrior to 44 in the Audacious. The gradual perfection of steel manufacture coming to their assistance permitted the English by partially introducing it to reduce the weight to 40 per cent. At this point the French take up the iron hull and with the Devastation reach 39 per cent. The Austrians, appreciating the value of the saving in weight of hull, build an all-steel hull in the Tegetthoff, bringing the weight to its present minimum of 34 per cent. Since iron manufacture has never been in so advanced a state in France as in England, it is safe to state that had the Gloire's hull been of iron, it would have absorbed at least 52 per cent of the displacement, a very serious matter in the first stages of iron-clad building. The wisdom of choosing a wooden hull is then sufficiently shown in this one point of saving 6 per cent in weight, and as the French had commenced with a complete armored side, they could not build in iron until the weight of that system was reduced to that of wood. This necessity was all the more urgent as the percentage of armor increased more rapidly than that of hull diminished. From the Gloire to the Richelieu and from the Warrior to the Hercules the regularity of increase is remarkable, being about the same in both countries, and yet an examination of the weight of hull and armor together shows the French to have the advantage. A strictly true comparison of percentages of armor, however, would necessitate a closer examination of the system of application than is permissible in a general summary.

The advantages of a light hull, however, are well shown in the respective percentages of the Devastation and Tegetthoff. The 39 per cent of the Devastation is far beyond the English limit, but it also brings the hull and armor together about the same amount in advance, which is a clear disadvantage to other factors. By saving on the hull, however, the Tegetthoff gets the same high per cent of armor, while weight of hull and armor together are at the very lowest limit.

Passing to the second-rates we find the weight of hull averaging higher and that of armor lower, bringing the total weight about the same. The Duke of Edinburgh is of a special type which can hardly be compared with the others. Her hull of 38 per cent is evidently of iron and steel in the best combination, whilst her very low percentage of armor shows at once that it is extremely limited, bringing the total at least 12 per cent below the average, the reason for which is shown at once by referring to weight of engines and coal, which are carried far beyond the average. This vessel is intended to steam 16 knots, with a coal capacity for 6000 miles at 10 knots.

Turreted vessels having a low freeboard should naturally have a smaller percentage of weight of hull, which is found in the heavier types to range between 30 and 34 per cent (excluding the Peter the Great, which is of a comparatively early construction). As an offset to this, armor is applied until the difference is made up, bringing the total weight about the same. The Onondaga deserves especial examination, as showing the attention (?) paid by Americans to this point. Her weight of hull is 15 per cent more than that of the heaviest wooden hull amongst the French frigates, and 33 per cent more than that of the Javary, a vessel of an exactly similar type. Her armor, turrets included, is 3 per cent *less* than that of the Gloire, instead of being, as it should, 15 per cent more, and 25 per cent less than that of the Javary. Hull and armor together are at least 10 per cent above the average. By a bad construction of hull a clear 30 per cent of weight was completely wasted.

The very low percentage of ordnance seems no doubt strange to many who talk loosely of heavy guns and projectiles without thinking that this element is one of solid dead weight occupying an immense space. From 5 to 7 per cent includes the entire range, from the vessel sacrificing ordnance to speed to the one with a maximum of ordnance and moderate speed, the Duke of Edinburgh being again an exception. The limits of weights of engines and boilers may be placed at from 11 to 13 per cent, and those of the coal supply from 8 to 11 per cent. Great diversity should be expected in the percentages of ordnance, engines, and coal in the second-rates, depending upon their special objects, yet as is seen there is scarcely 4 per cent difference between the extremes. The remaining percentage should be about the same throughout, with a slight variation for the proportion of sail-power, the total allowance for this latter being from 1 to 3 per cent.

By means of these tables the beginner may get an adequate idea of the limiting proportions of the main elements of a

vessel. It is seen that the factor absorbing the greatest proportion of the displacement is the one that calls for a reduction, all others requiring extension. Weight of hull is an obstacle. In armor, by an increase of percentage an increase of defensive power is gained; with ordnance, an increase of offensive power; with boilers and engines, an increase of general effectiveness; with coal, an increase in endurance; while the percentage of spars, crew, and stores is a necessary constant. Thus the development of naval construction is seen to be a matter of vital importance. Had the Onondaga been properly constructed there would have been a useful percentage of fully 20 per cent to have been distributed in making her a sea-going vessel. This fact is plainly brought out in the breastwork modifications of the monitor type, in which the breastwork is a clear addition of dead weight on a similarly formed and proportioned body without being of any assistance as additional free-board. From the results attained in the Tegetthoff the lowest limit of weight of hull attainable with present perfections of steel construction may be placed at 34 per cent for first-rate frigates and about the same for second-rates. For turreted vessels it may fall to 28 or 27 per cent.

Although weight of armor is in a manner a direct measure of defensive power, it is an objectionable feature and one whose difficulty of counteraction has been almost insurmountable owing to the excessive cost of steel, whose superiority in the end was extremely doubtful. Within the past few years, however, a happy combination of iron and steel has been made which will go far towards saving percentage in weight, although apparently it will for some time to come make a saving in this direction of only the percentage between iron and steel framing. With iron framing and compound armor the same results of weight of hull and armor together may be attained that now hold with steel framing and iron armor, with the advantages of an increase in defensive power at about the same cost.

Wherever it is a question of rearmoring vessels, the compound armor is a great gain to the fighting power of the vessel, although in general the expense of the change is more than the result would warrant. The highest advantages of this armor are reaped by the second-rate cruisers, who retain their speed and coal capacity with an increase of defensive power that brings them within the fighting lines of first-rates.

Capacity for fuel is a matter of the greatest importance in time of war. England alone of all the maritime nations can afford to neglect this point. A man-of-war without steaming-power in war-time is helpless, and yet by the precepts of

international law she is debarred from getting this material in foreign ports. Russia, having a peculiarly vulnerable home coast, easily closed and hard to reach, has with great wisdom sacrificed all qualities in her fast cruisers to the two of speed and coal capacity. Keeping her sail-power as the constant factor, the two important ratios of ordnance and armor are reduced to the lowest point, their gain being entirely transferred to the coal capacity.

In considering the most advantageous method of placing and distributing armor, problems without end arise whose consideration requires the most careful weighing of all the different circumstances of its use, and yet it is in this particular that are generally found the most positive assertions and criticisms from those who have given but little or no attention to the subject. For the protection of the battery and above-water sections of a vessel the extremes of position of armor are the vertical, giving the greatest possible extent of protection, and the horizontal, giving none.

Arguments without end are found in favor of this or that type, varying between the two limits. The truth is, however, that there is scarcely any choice between these extremes. Experiment has fully proved that inclining armor at any angle less than 50° is of itself no advantage as regards preventing penetration. Beyond this angle the great increase of weight necessary to make up the vertical space required necessitates a curtailment in extent of armor entirely neutralizing all the benefits of the inclination. There is left then no choice between the vertical complete protection and the horizontal or armored-deck system giving none whatever. In the vertical protection the question of distribution presents itself anew, varying between the long rectangle and the circular turret. The minimum turret diameter may be safely taken at 20 feet inside. Here the greatest economy of room is attained, but this economy involves a reduction in the number of guns, a limitation in the position, and, unless the French barbette turret be used, the possibility of disabling at one blow the greater part of the offensive power of the ship by jamming the turret. With the same amount of armor that is used in a turret of 20 feet, the broadside may be well covered for a length of from 15 to 18 feet, giving protection to double the number of guns. This advantage, however, is purchased at the expense of a more unfavorable disposition of weight and a complication of upper-work framing. These points bear directly upon the service for which the vessel is intended, and are so intimately connected with the whole general type of the vessel that it becomes the most complete absurdity to assert that turrets alone

or armored broadsides alone shall be used. As weight of armor increases, the extent of its protection becomes one of the most serious of questions. In ten years from the date of its introduction it became impossible to completely protect the hull of the frigate, and in fifteen years we find it necessary to commence to strip the turreted vessel with her minimum of freeboard. If the greatest architects of the world find themselves almost at a loss to retain the effectiveness of the armor carried whilst keeping within proper bounds in weight, it is certainly idle for those who barely appreciate the necessity for covering battery and steering-gear to assert that armor should be carried thus and so.

The application of horizontal armor presents problems equally abstruse; more so in fact to the designer who does not fully appreciate all the obstacles to be surmounted and the real advantages which are to be obtained. A vessel having a heavy steel deck that shall fully protect her under-water sections and yet permit of such a division of above-water spaces as to permit her to be pierced with impunity whilst that space is left available for the many necessities of circulation and storage, is a consummation of architectural skill the most difficult of attainment.

The matter of properly proportioning the vital factors of a man-of-war, be she iron-clad or unarmored, is one of the highest consideration. To speak of designing ships to carry 40-ton guns and have a speed of 16 knots, and at the same time not to consider what are the absolute limitations in their construction, is as senseless as to attempt to rebuild a monitor without first finding out whether she will float or not after she is built. The Onondaga is an example of the first method of construction, the Puritan of the second. These two vessels represent the condition of naval architecture and construction in the United States for a period of ten years during which the naval architects of all the rest of the world have been advancing at giant strides.

Whilst then we may leave out of consideration those types of vessels which have clearly proved failures, there is not a single one that has been in any way successful that is not deserving of the closest attention and study. Whilst amongst English types we find the greatest diversity of application combined with the very highest architectural skill and development, it must not be forgotten that France, Italy, and Austria have architects second to none in the world, men whose national jealousies and ambitions lead them to totally independent lines of thought and action and whose works are worthy of the highest praise.

PART V.

PERSONNEL.

ORGANIZATION—FLEET DIVISION—BUDGETS.

PERSONNEL.

ARGENTINE REPUBLIC.

THE navy of this country is as yet not fully or independently developed, its administration and budget being incorporated with that of the army. All vessels of a larger size than gun-boats have been purchased from foreign governments, and until lately there have been no facilities for the repair of ships; at present, however, a dock-yard is in course of construction at Zarate, which when completed will furnish docking and repairing facilities for first-rate vessels. This yard is, however, hardly to be considered a building yard. Engines, boilers, and ordnance will be purchased from foreign markets for some time to come, as the mechanical industries are not yet sufficiently developed to permit the establishment in the country of the necessary machine-shops. A naval school has been established and measures have been taken to introduce apprentice instruction.

The personnel of the Argentine fleet is divided into three corps or divisions:

NAVAL DIVISION.

2 Fleet Commandants.	22 Cadets.
5 Colonels.	43 Midshipmen.
8 Lieutenant-Colonels.	7 Paymasters.
6 Majors.	26 Machinists.
7 Captains.	748 Men.
26 Lieutenants.	— Apprentices.
Total.....	900

MARINE INFANTRY AND ARTILLERY DIVISION.

2000 Men (National Guard).

TORPEDO DIVISION.

3 Chiefs. 8 Officers. 80 Men.

The yearly budget of the navy is about \$700,000, or a little less than one twenty-fourth of the entire national expense.

There are no cruising squadrons as yet, although more than half of the fleet is kept constantly in commission, policing the coast of Patagonia and the home coast.

AUSTRIA.

The Imperial Council being composed of three Ministers only, holding respectively the portfolios of foreign affairs, war, and finance, the navy although a branch of imperial control (as distinguished from the separate cabinets of Austria and of Hungary) is not distinctively recognized in the Council. The head of the Marine Section of the Ministry of War is a Vice-Admiral, who is Commander-in-Chief of the fleet and under whose direct control is placed the superintendence of all the departments of the navy, the Admiralty of the war station of Pola, and the command of the maritime district of Trieste.

The personnel of the navy has a double "cadre," one for war and another, somewhat reduced, for peace, there being during time of peace a reserve division of officers composed of those whose services can best be spared. The corps and grade divisions of the personnel correspond with those of other navies, the names and cadres being as follows:

SEA OFFICERS.

WAR.	PEACE.		WAR.	PEACE.
1	1	Admiral } Complimentary Grade.	146	100
3	2	Vice-Admiral.	73	50
7	6	Contre-Admiral.		
22	16	Linienschiffs Capitän.	216	155
21	19	Fregaten Capitän.	244	163
25	22	Corvetten Capitän.		

MARINE INFANTRY.

1	1	Contre-Admiral.	19	19
1	1	Linienschiffs Capitän.		
4	4	Fregaten Capitän.	9	9
3	3	Corvetten Capitän.		
			10	10

MARINE PRIESTHOOD.

1	Marine Pfarrer.	2	Marine Curat.	6	Marine Kaplan.
---	-----------------	---	---------------	---	----------------

(The Pastor and the Curates have permanent duty on shore.)

MEDICAL CORPS.

1	1	Oberster Marine-Arzt.	23	18
2	2	Marine-Ober-Stabsarzt.	25	18
4	4	Marine-Stabsarzt.	29	19

TECHNICAL DEPARTMENT.

Ship Building.

1 Oberster Ingenieur.	8 Ingenieur, 1 Klasse.
1 Oberingenieur, 1 Klasse.	8 Ingenieur, 2 Klasse.
2 Oberingenieur, 2 Klasse.	8 Ingenieur, 3 Klasse.
2 Oberingenieur, 3 Klasse.	4 Elève.

Engine Building.

1 Oberster Ingenieur.	3 Ingenieur, 1 Klasse.
1 Oberingenieur, 1 Klasse.	3 Ingenieur, 2 Klasse.
1 Oberingenieur, 2 Klasse.	4 Ingenieur, 3 Klasse.
2 Oberingenieur, 3 Klasse.	

Marine Artillery.

1 Oberster Ingenieur.	3 Ingenieur, 1 Klasse.
1 Oberingenieur, 1 Klasse.	6 Ingenieur, 2 Klasse.
2 Oberingenieur, 2 Klasse.	6 Ingenieur, 3 Klasse.
2 Oberingenieur, 3 Klasse.	6 Elève.

Building and Dock Construction.

1 Oberster Ingenieur.	1 Ingenieur, 1 Klasse.
1 Oberingenieur, 1 Klasse.	1 Ingenieur, 2 Klasse.
1 Oberingenieur, 2 Klasse.	2 Ingenieur, 3 Klasse.
1 Oberingenieur, 3 Klasse.	

Machinists.

2 Ober Maschinist.	35 Maschinist, 2 Klasse.
20 Maschinist, 1 Klasse.	55 Maschinist, 3 Klasse.

COMMISSARIAT DEPARTMENT.

1 Marine-Generaicommissär.	14 Marinecommissär-Adjunct, 1 Kl.
4 Marine-Obercommissär, 1 Klasse.	41 Marinecommissär-Adjunct, 2 Kl.
4 Marine-Obercommissär, 2 Klasse.	41 Marinecommissär-Adjunct, 3 Kl.
12 Marinecommissär.	14 Marinecommissär- Elève.

The number of enlisted men in time of peace is 5836, increased for a war footing to 11,532. These men are all drawn for service from the coast provinces, their length of service being three years in the fleet and seven in the reserve. From the time that men are drafted into the service until they pass into the reserve a thorough system of education is followed out. The depot for their reception is at Pola, where the recruits (received first in shore barracks) are divided into twelve companies, the arrangement being as nearly as possible in conformity with the intelligence of the individual. Company No. 6 is made up entirely of firemen and coal-heavers; Company No. 12, workmen employed in the gun-foundries and

RELATIVE RANK.

Rear-Admiral.....	Commissary-General.	Medical Commandant...	Engineer Commandant.	Chief Machinist.....	Naval Pastor.
Line-Ship Captain....	Chief Commissary, 1st class.	Medical Chief of Staff....	Chief-Engineer, 1st class.	Machinist, 1st class..	Curate.
Frigate Captain.....	“ 2d “ ..	Staff Surgeon.....	“ “ 2d “ ..	“ “ 2d “ ..	“ “ 2d “ ..
Corvette Captain.....	Commissary	Line-Ship Surgeon.....	Engineer, 1st class.....	“ “ 3d “ ..	“ “ 3d “ ..
Lieutenant, 1st class..	Asst. Commissary, 1st class..	Frigate Surgeon.....	“ 2d “ ..	“ “ 3d “ ..	“ “ 3d “ ..
“ 2d “ ..	“ “ 2d “ ..	Corvette Surgeon.....	“ “ 3d “ ..	“ “ 3d “ ..	“ “ 3d “ ..
Ensign.....	“ “ 3d “
Midshipman.	Commissary Cadet.....	Engineer Cadet.
Cadet.....

dock-yards. The remaining ten companies are the sailors of the fleet. Whilst in the company, the recruit is taught the elements of the drills and discipline, and a certain time is devoted each day to teaching reading, writing, and more especially the German language, as a great number of the recruits are totally ignorant of any tongue except that of their native province.

As the recruits advance in instruction, they are picked out for the formation of classes for instruction aboard ship, and at certain intervals a class is transferred to the guardship *Bellona*, where their instruction is extended somewhat, and during the course on this ship selections are made of those who are best qualified to become helmsmen and gunners. The course of instruction on this ship lasts for from six weeks to two months. From the *Bellona* the classes are transferred to the different school-ships in accordance with the especial line of instruction that is to be followed. The seamen go to the corvette *Minerva*, to which vessel also recruits who are already sailors are sent direct from the depot without passing through the *Bellona*, and men who have passed either

the helmsman's or gunner's course come here for their final course of seamanship. The *Minerva* is kept cruising almost constantly for exercise in seamen's duties, and the course of a class is about six months. At the end of this course those who show sufficient aptitude are transferred to the other ships for the complete course; the remainder, as well as all men who have passed the entire course, return to the depot, forming one or more of the twelve companies in readiness for transfer to any ship going into commission.

Those who are found too stupid or vicious to learn within a reasonable time are transferred from the ships to the depot, where they do the police work and are drafted as landsmen into cruising ships. The sloop *Saida* is the instruction vessel for helmsmen and quartermasters, the course being about three months. Men passing from the *Bellona* to the *Saida* are transferred to the *Minerva* for the final seamanship course, whilst the best of those from the *Minerva* pass to the *Saida* and thence to the gunnery-ship for complete instruction. The *Adria* is the gunnery-ship, the term of service being of the same length as that of the *Saida*. On board of this ship there is the ordinary gunner's course, a superior course for those seamen who are selected for non-commissioned officers of marine infantry, and an officer's course, the higher petty officers who are intended for instructors aboard ship being admitted to the latter.

There is attached to the depot a school for machinist petty officers, having for its object the perfection of the theoretical and practical knowledge of the workmen chosen from amongst the most capable of the 12th company. The length of the course is fixed at one year, at the end of which time an examination is held, and those who pass successfully are appointed machinists and embarked in cruisers at once; the remainder are returned to the depot for subordinate duties. For certain of those who in depot give promise of final success without having the knowledge requisite for an immediate entry into the machinist school, a preliminary six months' course is provided.

This system is a temporary one to furnish machinists until the thorough establishment of a new machinists' apprentice school, the duration of instruction in the latter being three years. This school is intended exclusively for the children of persons who have served in the navy. The entrance age is between fourteen and seventeen, and the children must already have served a partial apprenticeship in a machine-shop. They are obliged to serve for ten years in the navy after completing the course, and in case of failure for any cause except incapacity

they are obliged to render one year of general service for each year or part of year passed at the school. The number of apprentices is limited to 50, and whilst at the school they receive in addition to their clothing and sustenance eight cents a day.

There are in general about 2000 men in depot. The *Bellona's* complement is 300, the *Minerva's* 100, the *Saida's* 50, and the *Adria's* 500. The remainder of the cadre are embarked or on duty at the dock-yards. In addition to these and not counted in the general draft are the seaman apprentices, quartered on board the *Schwartzenberg* and numbering about 300. This school is open to all boys between the ages of fifteen and seventeen. The course is three years, with obligation to serve ten more after finally passing.

On leaving the apprenticeship at the end of the three years, the boys pass to the *Minerva*, *Saida*, and *Adria*, receiving certificates and advancement in grade in proportion to their aptitude. In case of failure to pass through the apprentice course they are transferred to depot to go through the recruit's course and serve out their time.

The Naval Academy is established at Fiume. The curriculum of the school is of the same grade as that of the municipal superior schools. Candidates are appointed by competitive examination, and must be between the ages of 13 and 15. The course is four years, at the expiration of which the student passes into service with the grade of cadet.

Aspirants are students passing into the service without having gone through the academy course. They must be between the ages of 15 and 17 and have successfully passed through the course of one of the municipal superior schools. Upon entering they take the regular course on board the school-ships, taking the grade of cadet at the final successful examination.

One - Year Volunteers.

This institution is a favor accorded to young men who, having prepared themselves by a course of study for a certain profession, do not wish to serve full time under their draft. During one year they receive naval instruction sufficient to fit them as sailors or petty officers in time of war. Particular attention is paid to as far as possible follow a course in consonance with their previous studies. At the end of the course they pass into the reserve. Professional mariners may enjoy this privilege upon presenting certificates stating that they have successfully passed examinations before any native or foreign marine school. They must in addition thoroughly understand

German and one other of the languages spoken generally throughout the empire. During their year of service they receive the pay of third-class seamen and their clothing. After passing the different school-ships they enter the reserve as officers if there are vacancies, otherwise as cadets. Students who are preparing themselves for engineers follow the courses of machinists or constructors in the same way. Students whose professions are in no way in accordance with that of the naval officer are sent to the Adria for a thorough course of gunnery. They enter the reserve at the end of a year as petty officers or seaman gunners, according to the rate of their examinations. Medical students have their year of service confined strictly to hospital duty, passing into the reserve as medical cadets, to serve as such in hospitals only, during war-time. Doctors having diplomas practise for a year in the hospitals and pass to the reserve with the grade of lieutenant. They are liable for sea service in time of war.

The depot, school-ships, machinists' school and apprentice school are all at Pola, and at the same place there is a school for the children of both sexes of people in the naval service in indigent circumstances.

In addition to these departments of the navy, there is a Hydrographic Department, charged with the care of the Observatory, correction of charts, and preparation of almanacs; the Permanent Artillery Commission, charged with all ordnance experiments; the Permanent Commission of Naval Constructions, charged with the examination of all modifications and improvements in the construction and outfit of war-vessels; the dock-yard at Trieste; and the arsenal at Pola. The iron-clads and large wooden vessels of the Austrian Navy are built in the private ship-yards of San Marco and San Rocco at Trieste, under the superintendence of constructing engineers. These yards are fully equal to building iron-clads of the largest type.

Austria has no foreign squadrons in time of peace. Her foreign cruisers are wooden corvettes which make cruises of from one to two years' duration. Her iron-clads are commissioned singly to cruise for short periods in the Adriatic. In time of war her whole iron-clad fleet is put in commission, the fleet being divided into squadrons of nine vessels each.

BRAZIL.

The Emperor of Brazil is Commander-in-Chief of the land and naval forces of the empire and President of the Supreme Council of War. The navy has a separate representative in the Cabinet, the Minister of Marine being always a civilian. In

the Supreme Council of War the navy is represented by four members, naval officers of the highest grades. The organization of the naval ministry consists of a civil and a naval department. The head of both departments is the Minister, assisted in the civil one by a Director-General, four Directors of sections and the under-officers of the sections. The naval department consists of a Naval Council having a vice-president, members, and a secretary. In addition to the Naval Council there is an Adjutant-General's Bureau with a vice-

Admiral at the head who is the immediate executive, a Controller's Bureau and a Finance Bureau, all within the limits of the Navy Department proper. There are five naval arsenals, situated at Rio Janeiro, Bahia, Pernambuco, Pará, and Matto Grosso. At the ports of Rio Janeiro, Espiritu Santo, Bahia, Sergipe, Alagoas, Pernambuco, Parahyba, Ceará, Rio Grande do Norte, Pianhy, Maranhão, Pará, Matto Grosso, Rio Grande do Sul, Porto Alegre, Santa Catarina, Parana, and San Paulo are established offices of naval control under the superintendence of a Captain of the Port, these places being recruiting depots. In addition to these departments there is a Naval School, Observatory, and Library at Rio Janeiro.

The naval personnel is divided into two main classes, the active and the reserve, the latter forming a very small minority. The grade divisions of rank are as follows:

There is a corps of pilots having no relative rank, and chaplains are assigned from the different sees without rank.

Warrant officers have the

Almirante			
Vice-Almirante			
Chefe de Esquadra			
Chefe de Divisão.....			
Capitão de mar e guerra.		Commissario de numero de não.	
Capitão de fragata			
Capitão tenente		Commissario de primeira classe.	
Primeiro tenente.....			
Segundo tenente.....		Commissario de segunda classe..	Machinista de primeira classe.
Guarda marinha.....		Commissario de terceira classe..	Machinista de segunda classe.
Aspirante.....			Machinista de terceira classe.

grade of second lieutenant. Machinists are graded into first, second, and third class, the first class having the grade of second lieutenant and the others no official grade.

Candidates for entrance into the Naval Academy are required to be between the ages of 14 and 17. The duration of the course is three years, during which time the exercises are pursued almost exclusively on shore. At the date of graduation the cadet takes rank at once as midshipman. The average complement at the Academy is 100. The cadre of the personnel of the navy is 821 officers, 100 cadets, 2993 men, 842 men of the marine battalion, and 1528 apprentices; total, 6184.

The Brazilians have no foreign squadrons, their practice being to send occasional cruisers to different parts of the world. Their own waters are, however, divided into squadron cruising grounds as follows: Sea coast, three districts, each employing a squadron of from three to seven vessels; river stations, five, as follows: Rio Grande do Sul, Uruguay, Amazon, Paraguay, Rio Plata, each one having a flotilla of from six to twelve gun-boats and iron-clads.

CHILI.

There is no distinct Navy Department in Chili, that administration forming one of the sections of the War Department, having one of the senior naval officers at its head. The central administration is at Valparaiso, and is in reality controlled by the civil governor of that district, who has on his staff a naval officer with the title of Major-General, for the superintendence of maritime affairs. Attached to the naval section are a Hydrographic Office, Observatory, and Naval School, and an Apprentice School. The navy is manned in time of peace entirely from voluntary enlistment. The war cadre is not known. That for peace is 148 officers and 5400 men, in addition to which there is a battalion of marine infantry and a battalion of marine artillery of the Civil Guard, amounting in all to 1200 men, making a grand total of 6800.

The grades of Chilian naval officers correspond to those of other services, except that there is no grade of Admiral. The Chilians have neither foreign cruising squadrons nor single cruisers, except an occasional single ship visiting the northern Pacific ports and the Brazil coast. There is but one dock-yard for general repairs at Valparaiso. The vessels composing the fleet with the exception of small gun-boats are purchased in foreign markets. The navy, although small, is in excellent discipline, and is rapidly developing in strength and general efficiency.

CHINA.

The control of naval affairs forms one of the sections of the Ministry of War, the central administration being at Peking, whilst the general administration is divided amongst three coast districts, at each of which is a dock-yard for construction and repair. To these districts correspond three distinct fleet divisions; 1st, Canton squadron; 2d, Foo Chow squadron; 3d, Shanghai squadron. At Foo Chow are the principal machine-shops and building-yard; at Shanghai the powder factory and arsenal; at Canton the naval school-ships. The fleet is manned by a coast conscription, the length of service being indefinite; cadre unknown.

ENGLAND.

The government of the navy is vested in a board known as the Board of Admiralty. This board consists of five members, namely: the First Lord, who is always chosen from civil life and is a member of the Cabinet; the Senior Naval Lord (naval officer); the Third Lord (naval officer); the Junior Naval Lord (naval officer), and the Civil Lord (civilian). Under the board is a Parliamentary Secretary, changing, like the five lords, with the government in power. The fixed administration, independent of political parties, consists of one permanent Secretary (naval), a Controller of the Navy (Vice-Admiral), Accountant General (naval), Director-General of the Medical Department (naval), Director of Engineering and Architectural Works (army), Director of Transports (naval), Director of Contracts (naval), Director of Naval Construction (naval), Director of Naval Ordnance (naval), and a Superintendent of Victualling and Stores. The First Lord has supreme authority and all questions are settled by his decision. The Senior Naval Lord directs the movements of the fleet and is responsible for its discipline. The Third Lord has the management of the dock-yards and superintendence of ship-building. The Junior Naval Lord deals with the victualling of the fleet and with the transport department. The Civil Lord has control of the accounts, and the Financial Secretary has charge of the purchase of all stores. The immediate chiefs under the board are the heads of bureaus or departments. In addition to those above named there are others not directly connected with the Admiralty Administration: the Chief of the Hydrographic Bureau, the Adjutant-General of Marines, the Astronomer Royal, and the President of the Naval College.

In the central administration the financial secretary assisted by the Civil Lord exercises a rigorous control over all the

expenses, guarding against extravagance by means of a system of inspection. For this duty there are two bureaux, the agents of which carry on a rigorous and personal inspection of all coming within their provinces in the different dock-yards. The inspectors of the first bureau are : 1 inspector of machinery, 1 inspector of works in progress, 1 inspector of timber, 2 examiners of completed works, 2 examiners of store accounts. In the second bureau are : 1 inspector of coal, 3 inspectors of dock-yard accounts, 1 examiner of shop accounts, and 1 inspector of buildings and coast-guard posts.

For the general administration there are four naval establishments of the first class, Portsmouth, Devonport, Chatham, and Sheerness, and four of the second class, Deptford, Woolwich, Pembroke, and Haulbowline. In addition to these there are 15 colonial depots : Gibraltar, Malta, Halifax, Bermuda, Antigua, Jamaica, Ascension, Sierra Leone, Cape of Good Hope, Trincomalee, Singapore, Hong Kong, Esquimalt, Sydney, and Queenstown.

The four first-class home stations are each under the immediate command of a commander-in-chief of the station. The Admiral exercises a military command over all the personnel of the reserve, the depots, school-ships, and vessels in commission. The discipline, instruction, and inspection are under his immediate direction. He has charge also of the police of the coasts and harbors of his district in time of peace and their defence and protection in time of war. With regard to the administration of the dock-yard he is only charged with a general surveillance, and under ordinary circumstances he never interferes with its affairs. He has the power to interfere in cases of necessity, but is obliged under such circumstances to render an immediate account of his actions to the Admiralty.

The immediate command of the dock-yard is entrusted to a Rear Admiral superintendent, whose assistants are the heads of the different departments of works.

The navy is manned entirely by voluntary enlistment. There are two main cadres of personnel, the active force and the reserve. The latter force is kept up by voluntary enlistment for periods of five years, with obligation to serve twenty-eight days in each year. This service carries with it certain marine privileges, pay, and after twenty years of service a life pension. Its advantages correspond quite closely to those of a life insurance. The apprentice system is also a permanent source of supply to the active personnel.

The period of enlistment in the active service is for five years, with increase of pay and allowances for continuous service.

GRADES AND RELATIVE RANK IN THE BRITISH NAVY.

EXECUTIVE CORPS.	MEDICAL CORPS.	SECRETARY'S CORPS.	PAY CORPS.	ENGINEER'S CORPS.
Admiral of the Fleet } Honorary.				
Admiral.				
Vice-Admiral.				
Rear-Admiral.	Inspector-Gen'l of Hospitals.			
Captain of the Fleet } Brevet.....	Inspector-Gen'l under 3 yrs.			
Commodore }				
Captain.....	{ Deputy Inspector - Gen'l } { of Hospitals. }	{ Secretary to Admiral } { of the Fleet. }	Paymaster-in-Chief.....	Chief Inspector of Machinery. { Inspector of Machinery afloat } { after 3 years. }
Captain under 3 years.....	{ Deputy Inspector - Gen'l } { under 3 years. }	{ Secretary to Comman- } { der-in-Chief. }	{ Inspector of Machinery under } { 3 years. }
Commander.....	Fleet Surgeon.....	{ Sec'y to Com-in-Chief } { under 5 years. }	{ Paymaster at 15 years' } { seniority. }	{ Chief - Engineer at 15 years' } { seniority. }
Lieutenant after 8 years.....	Staff "	Secretary to Flag Officer..	Paymaster of 8 years.....	Chief-Engineer of 8 years.
Lieutenant.....	Surgeon.....	Secretary to Commodore..	Paymaster under 8 years..	Chief-Engineer under 8 years.
Sub-Lieutenant.....			Assistant Paymaster.....	Engineer
Chief Gunner.				
Chief Boatswain.				
Chief Carpenter.				
Midshipman.....			Clerk.....	Assistant Engineer.

The coast-guard service, although not strictly naval, forms an auxiliary naval force, and is drawn entirely from the personnel of the navy. No person is eligible for the coast-guard who has not served eight years in the Navy and who has not qualified as a trained man or a seaman gunner.

The effective cadre of the British Navy is as follows :

OFFICERS.	MEN.
Executive Corps.....2,252	Petty Officers.....16,500
Engineer Corps..... 870	Blue Jackets, Firemen, etc...18,600
Pay Corps..... 526	Boys..... 6,300
Chaplains..... 164	Coast Guard..... 3,954
Medical Corps..... 415	Naval Reserve.....18,000
Coast Guard..... 346	
Naval Reserve..... 405	Total.....63,354
	Officers 4,978
4,978	Grand total.....68,332

In addition to this cadre there are two corps of marine troops. The marine infantry, intended exclusively for service aboard ship, consists of three divisions of sixteen companies each, comprising in all 300 officers and 11,092 non-commissioned officers and privates; the marine artillery, intended for garrison duty and to a limited extent as gunnery servants on board ship (in the proportion of 32 to a first-rate), 16 companies, comprising a cadre of 100 officers and 2800 non-commissioned officers and privates.

The number of civil employés in the dock-yards amounts to about 20,600.

Officers of the executive corps are drawn exclusively from the naval school established on board the school-ship *Britannia*. Those of the engineer corps are drawn from the engineer school-ship *Marlborough*. The other corps are drawn from civil life.

The Royal Naval College at Greenwich is an institute at which officers of the executive, construction, and engineer corps take an advanced course of instruction, for the purpose of raising the standard of naval education and efficiency. All officers between the grades of captain and sub-lieutenant are eligible after passing a preliminary examination. This institution, organized first in Great Britain, is rapidly being developed in all the other European navies.

At the Portsmouth dock-yard there is a special gunnery and torpedo school for the purpose of advanced instruction.

The highest grade of officers in the naval reserve is that of lieutenant. This grade is opened to masters of the merchant service under 45 years of age. The grade of sub-lieutenant is

open to the chief mates of the merchant service. The grade of midshipman is open to young gentlemen who have served not less than two years in one of the mercantile training-ships, and who are not over 18 years of age. There is an honorary reserve corps in which the grade of commander is reached, officers of this corps having served in the active reserve.

The course of instruction at the naval school-ship (Britannia) is two years, and the required entering age is between 12 and 13½.

All cadets, midshipmen, and acting sub-lieutenants in active service are required to pass a written examination every year on board the ship where they may be serving. The results of these examinations are forwarded to the Admiralty, and it is by means of them that these officers take their rank in the grade of sub-lieutenant. Those officers who make a specialty of gunnery or navigation and pilotage receive extra pay while doing duties in these specialties. A premium of extra pay is also offered to those officers who acquire fluency in some one of the generally used modern foreign languages.

The squadron divisions for foreign service exclusive of colonial-port stations are:

Channel Squadron.
Mediterranean Squadron.
North American Squadron.
Pacific Squadron.
China Squadron.

East India Squadron.
Australian Squadron.
Cape of Good Hope Squadron.
East Coast of Africa Squadron.
South American Squadron (Brazil).

The average strength of a squadron during time of peace is eight vessels, the great majority being light corvettes and gun-boats.

An independent naval establishment has been organized for the protection of the interests of the Indian Empire, called the Indian Navy. There are also independent Australian and Canadian services at the support of the colonies, and regarded as auxiliary forces for colonial coast-defence.

FRANCE.

The French Navy is represented in the Cabinet by a Minister of Marine, who is invariably chosen from the active list of Admirals. The Minister has as his immediate assistant and Chief of Staff a Vice or Rear Admiral. The central administration of naval affairs is the Naval Ministry at Paris, composed of a Ministers' Cabinet and five Sections or Directions, which are subdivided into Bureaus.

FIRST DIRECTION.

Personnel.—First Bureau: The Staff of the Fleet, controlling all affairs of the Admiralty Council, prefectures, officers, naval schools. Second Bureau: Technical Corps and General Agents, having charge of construction and engine corps, hydrographic office, commissariat clerks, chaplains, hydraulic engineers, watchmen, etc. Third Bureau: Sailors of the Fleet and Maritime Justice. Fourth Bureau: Marine Infantry and Artillery.

SECOND DIRECTION.

Matériel.—First Bureau: Naval construction and hydraulic works. Second Bureau: Ordnance. Third Bureau: Equipment.

THIRD DIRECTION.

Administrative Service.—First Bureau: Naval inscription and navigational police (control of merchant service). Second Bureau: Fisheries and maritime control. Third Bureau: Pay and clothing. Fourth Bureau: Subsistence and hospitals.

FOURTH DIRECTION.

Colonies.—The administration of colonial affairs is entirely under the direction of the Minister of Marine.

FIFTH DIRECTION.

General Accounts.—First Bureau: Funds and regulations for their expenditure. Second Bureau: Expenses abroad. Third Bureau: Examination of accounts. Fourth Bureau: Examination of receipts and expenditures. Fifth Bureau: Interior service, archives, and libraries.

These being the main divisions of control, there are certain commissions intimately connected with the regulation of affairs, most of the committees being permanent in character.

The Council of Naval Works examines the technical points connected with the introduction or manufacture of naval material.

The Superior Council of Health superintends sanitary matters.

The Council of Captures and Losses regulates prizes and reimbursements.

The Lighthouse Committee controls all lighthouse affairs.

The Forestry Committee has charge of all standing timber and timber lands.

The Committee of Inspection of Fuel has charge of the purchase, storage, and issue of fuel.

The Permanent Commission of Control and Revision of the Regulations, Armament, and Clothing attends to all matters of change of regulation.

The Consulting Commission for the Arrangement of Disputes has general consultation superintendence.

The Superior Commission of Submarine Defences has control of torpedoes.

The Central Commission for the Examination of Works of Officers is a committee through whose hands pass all the naval reports made by officers for the benefit of the service.

The Permanent Commission of Libraries has charge of libraries for naval stations, ships, and prisons.

The Direction for the Regulation of the Affairs of Pensioners and retired people of the service forms a separate department of the Ministry. The Hydrographic Office, Bureau of Longitudes, Museum, Naval and Apprentice Schools and the Artillery experimental firing-ground of Gavre form separate departments.

The general administration of affairs is carried on at the naval ports. The maritime territory of France is divided into five grand districts, each under the control of a *Préfet Maritime*, who is a Vice-Admiral, Commander-in-Chief of the station; the districts are subdivided, each subdivision being under the control of a Chief and a Captain of the Port. The First District extends from the Belgian frontier to Cherbourg; headquarters, Cherbourg; sub-districts, Dunquerque, Havre, and Cherbourg. The Second District extends from Cherbourg to Quimper, including adjacent islands; headquarters, Brest; sub-districts, Saint Servan and Brest. The Third District extends from Quimper to the Loire, including adjacent islands; headquarters, L'Orient; sub-districts, Nantes and L'Orient. The Fourth District extends from the Loire to the Spanish frontier; headquarters, Rochefort; sub-districts, Bordeaux, Rochefort, and Bayonne. The Fifth District comprises the whole Mediterranean coast and Corsica; headquarters, Toulon; sub-districts, Marseilles, Bastia, and Toulon.

The *Préfet Maritime*, being at the head of maritime affairs in his district, is assisted by—1st. Major-General of Marine, who has immediate command of all the personnel in the district, the instruction of officers and men, details for dock-yard duty, library, observatory, hydrographic establishment, inspection

of vessels fitting out, and the receipt and transmission of reports. This office is as a rule filled by a Rear-Admiral. 2d. A Commissary-General, who has control of the receipt and distribution of funds, enlistment of civil employés, the direction of the marine inscription, administration of police, detail of officers of the commissary department, and general charge of all accounts kept in the district, receiving, arranging, and forwarding them. 3d. A Director of Port Movements (Captain of the Port), who has charge of all vessels either in or out of commission, superintending their movement, anchorages, ballasting, careening, entrance into basins, etc., charge of fire apparatus, clearing of channels, placing of buoys, lights, and signals. 4th. A Director of Naval Constructions. 5th. A Director of Artillery. 6th. A Director of Hydraulic Works and Buildings. 7th. A Council of Health, composed of the surgeons stationed in the district. All of these officers are found at the headquarters port; at the ports of the sub-districts there are always two naval representatives: 1st. The "Chef de Service," who is a Commissary-General and whose principal charge is in relation to the inscription. 2d. The Captain of the Port, who in general is a Lieutenant.

The French Navy is manned by voluntary enlistment and by inscription. Every seafaring person is placed upon the inscription list upon reaching the age of eighteen, and between that and twenty he is bound to present himself at the headquarters of the district within which he lives. Here he passes through a preliminary course of instruction on board the school-ships lasting for a few months, at the expiration of which time if his services are not required in the fleet he is granted a leave of absence, without pay, which may be extended from time to time. During this period he may make foreign voyages, the only restriction being that he shall not change his calling. At the end of five years he passes into the first reserve, where for a period of two years he cannot leave the country. At the end of this time he passes into the second reserve and is practically free, being only liable to service under especial circumstances. Special inducements are held out for seafaring people. None but those who are or have been inscribed are allowed to fish in French waters or to be employed on French coasting vessels. While they are serving their time, troops cannot be billeted on them; they travel at military rates, and have the benefits of naval hospitals and naval insurance.

In drafting for active service great care is taken to only draft those who can be best spared from their homes, leaving the others at almost entire freedom.

At Brest there is a special school of instruction for appren-

NAMES AND ASSIMILATED GRADES OF THE DIFFERENT NAVAL CORPS.

CORPS DE LA MARINE.	ART. ET INF. DE MARINE.	CORPS DU GÉNIE.	CORPS DU COMMISSARIAT.	CORPS DE SANTÉ.	MÉCANIENS.
Amiral.					
Vice-Amiral	Général de Division.	Inspecteur Général..	Inspecteur Général.	
Contre-Amiral	Général de Brigade..	Directeur.....	Commissaire Général....	Directeur de Santé.	
Capitaine de Vaisseau....	Colonel.....	Ingénieur de 1re class.	Commissaire de Marine..	Médecin en Chef.	
Capitaine de Frégate.....	{ Lieutenant-Colonel } { Chef de Bataillon }	Ingénieur de 2de class.	Commissaire Adjoint....	Médecin Principal.....	Mécanicien en Chef.
Lieutenant de Vaisseau.	{ 1re cl. } { 2de " }	Sous-Ingér { 1re cl. } { 2de " }	Sous-Commissaire.....	Médecin de 1re classe..	{ Mécanicien Princi- pal, 1re classe.
Enseigne de Vaisseau....	Lieutenant { 1re cl. } { 2de " }	{ Sous-Ingénieur de } { 3me classe.	Aide Commissaire	Medecin de 2de classe.	{ Mécanicien Princi- pal, 2de classe.
Aspirant { 1re classe... } { 2de " " " " }	Sous-Lieutenant.....	Élève.....	Aide Médecin.	

tices, who are received under ordinary restrictions with regard to age and character, and who are obliged to serve for ten years after finishing their apprenticeship. The apprentice school and the schools of instruction for the "inscrits" are amongst the best of their kind in the world, complete records being kept of every man under instruction and the system of rewards being such as to render the inscription a benefit to the seafaring population instead of being a draft on them.

All officers, without distinction of corps, below the grade of Capitaine de Frégate, are obliged once in two years to submit to the Minister of Marine an essay on any subject that is of interest to the profession. These essays are examined and reported upon by a special committee. Those that are unsatisfactory are returned, and the writer is required to furnish a satisfactory one within three months.

Those that are satisfactory are recorded or disposed of by being published at government expense in the *Revue Maritime* or *Journal Officiel*. Rewards for satisfactory essays range from an honorable mention to promotion and the gift of the "Légion d'Honneur." Officers showing an especial aptitude are placed on a list for special duty. In this way all departments requiring specialists are filled by the best talent of the service.

Promotions are by seniority except in the highest grades. Retirement takes place forcibly after 65 years of age or 45 years of active service. The officers of every corps are graduates of separate naval schools, except in the medical corps, where the naval tutelage consists of a course of naval-hospital practice combined with an advanced course of medical lectures. In time of peace the grade of Admiral is honorary, bringing no especial command except that of appointment by chance to Minister. The marine artillery and infantry do no service in the fleet. The former have charge of the manufacture of ordnance and the garrisoning of naval fortifications; the latter do garrison duty at dock-yards, arsenals, and in the colonies. The Génie Maritime superintend the construction of ships and engines, hydraulic works, buildings, hydrographic work, and civil-engineering duty. They have no duty in the fleet. Machinists have duty almost exclusively in the fleet or in the schools of instruction of firemen. The effective force of the fleet is 1783 officers and 46,500 men; in addition to this force there are 155 officers of Génie Maritime, 825 officers of commissariat, 557 medical officers, 61 chaplains, 63 machinists, 1769 persons connected with the administration; four regiments of marine infantry, 16,000 men; 4500 men of the marine artillery, and 5 companies of gendarmerie with a complement of 660, making a grand total of 71,104 exclusive of the civil employés of the administration. Properly the marine artillery and infantry should be excluded, as their service is principally colonial and carried on by the army in other nations.

The French have six foreign-squadron cruising grounds, in which are included the colonial stations. The squadrons are divided as follows:

MEDITERRANEAN.

1st. Squadron of evolutions; consisting of from nine to twelve iron-clads and several despatch vessels, having headquarters at Toulon and cruising throughout the sea. 2d. Station of Algiers. 3d. Levant division, consisting of one or two vessels stationed permanently on the Egyptian and Greek

coasts, and generally one cruising division of the squadron of evolutions. 4th. Constantinople station; one or two vessels stationed permanently at Constantinople and the mouth of the Danube.

NORTH ATLANTIC.

1st. Subdivision of Newfoundland and station of St. Pierre and Miquelon, a small squadron cruising on the fishing grounds. 2d. Division of the Antilles, a small squadron cruising on the United States, Mexican, and Central American coasts. 3d. Three stations of Martinique, Guadaloupe, and Guiana.

SOUTH ATLANTIC.

1st. South Atlantic division, cruising on the Brazilian coast. 2d. Senegal station, on the west coast of Africa.

CHINA SEAS.

1st. China seas division, cruising on the coast of China and Japan. 2d. Station of Cochin China, with cruisers on that coast, Siam, and the Dutch East Indies.

INDIAN SEAS.

Indian station, with cruisers at each of the French possessions.

PACIFIC OCEAN.

1st. Pacific division, cruising on the west coast of South America. 2d. Tahiti station. 3d. New Caledonia station.

These stations require during peace a total of about 75 vessels and 11,000 men.

GERMANY.

The navies of the different states of the empire are consolidated into a single one under the chief command of Prussia, controlled by an Imperial Ministry. The cabinet representative of the navy is chosen from amongst the General officers of the army, bearing, whilst Minister of Marine, the honorary title of Admiral, and having naval officers for his immediate staff. The Imperial Admiralty is divided into three grand sections: 1st. The Military Section, composed of the Bureaus of Mobilization, Naval and Military Affairs, General Military Affairs, Instruction, Exploration and Coast De-

fence, Justice, Sanitary and Medical Affairs. 2d. The Technical Section, composed of the Bureaus of Equipment, Docks, Construction of Vessels, Construction of Engines, Construction of Ordnance, Construction of Torpedoes and Torpedo Defence. 3d. The General Section, composed of Bureaus of Constructional Affairs, Budget and Pay, Administration of Garrisons, Indemnities, Judiciary, Hydrography, and Observatory. In addition to these sections there are connected with the Admiralty: 1st. A Commission for the Examination of Officers of Marine Superintendence. 2d. The Administration of the Naval Stations of Kiel, Wilhelmshaven, Dantzic, and Friedrichsort, and the Naval Academy.

The navy is manned by inscription from the maritime districts, the obligation of service commencing on the 1st of January of the year in which the age of 20 is reached. Active service continues for three years, at the end of which time men pass into the First Reserve for a further period of seven years, during which time they are called for exercise twice in four years in time of peace, and on the breaking out of war they are called into active service. At the end of the seventh year in the first reserve they pass into the second reserve for a further period of five years (*seewehr*). The Second Reserve also includes those who have been subject to service but who have not been called on: these latter are exercised twice in twelve years. Sailors of the merchant marine are authorized to present themselves between the ages of 20 and 24 years. Mariners who have followed the sea for five years have only to serve for one year; those who have been to sea four years serve two years. For tradespeople and mechanics the term of active service may be reduced to one year. The maritime population of Germany is estimated at 45,000 men, of which number 12,000 may be called into service at any time, not counting sailors of the merchant service absent from home.

The cadre of the executive corps of officers is as follows:

1 Admiral (Honorary).	75 Capitän-Lieutenant.
1 Vice-Admiral.	148 Lieutenant zur See.
4 Contre-Admiral.	128 Unter-Lieutenant zur See.
23 Capitän zur See.	100 See-Cadet.
45 Corvetten Capitän.	

The sailors of the fleet, divided into two divisions, one being stationed at Kiel and the other at Wilhelmshaven, number 821 petty officers and 5621 men. There is also one division of apprentices, numbering 12 petty officers and 400 boys.

Apprentices are entered between the ages of 14 and 16,

and engage to serve for twelve years. The first two years they are placed aboard cruising school-ships, and for another year they are under general harbor instruction. At the end of the third year they pass into the fleet, and if successful in their examinations they are promoted at once to seamen.

Officers of the Second Reserve are recruited from five different sources: 1st. From officers who have retired from active service and who are less than 31 years old. 2d. From masters of the merchant marine. 3d. From one-year volunteers who are seafaring people. 4th. From certain auxiliary officers. 5th. From young men who have successfully passed a master's examination. Persons from the last three categories must serve for one year at least in the fleet, at the end of which time they receive the brevet of Sub-Lieutenant of Reserve. Officers of the Reserve may be promoted after a certain length of service to the grades of Lieutenant and Lieutenant-Captain, and if they are under 24 years of age they may pass into the active roster.

Machinists are recruited from volunteers and also from tradespeople of the inscription, and before entering the fleet they pass through a course of dock-yard instruction. In the permanent fleet there are 24 Machinist-Engineers, divided into 3 Superior Engineer-Machinists, 9 Engineer-Machinists, and 12 Sub-Engineer-Machinists. The total cadre of the dock-yard division, which includes machinists, petty officers, mechanics, firemen, and coal-heavers, numbers 1475 men.

In the Pay Department there are 26 Commissaries and 29 Sub-Commissaries.

The Medical Corps comprises 1 Surgeon-General, 5 Surgeon-Majors, 17 Surgeon-Majors (subs), and 22 Assistant Surgeons divided into three classes.

The Marine Infantry consists of a single battalion of six companies, organized in a similar manner to the line of the army, and comprising in its cadre 47 officers and 984 men, there being a Colonel in command. The officers are all recruited from regiments of the line.

The detachment of Marine Artillery is composed of three companies organized similarly to the Fortress Artillery of the army; 112 officers and 346 men. This detachment mans the batteries and coast-works under the control of the navy. In time of peace it is employed principally in the fabrication of munitions. The officers are all recruited from army artillery regiments.

Attached to the infantry battalion is a small body called the staff-guard, consisting of 52 Sergeant-Majors and Sergeants, who have charge of the police duties aboard ship and at the dock-yards.

The Technical Corps of Officers forms two divisions, one of Naval Constructions and the other of Engine Constructions, having grades not assimilated with those of officers of the fleet. There are 62 officers in the corps.

	CONSTRUCTION.	ENGINES.
Directors	3	3
Superior Engineers.....	4	3
Engineers	11	11
Sub-Engineers	13	9

At Kiel a Naval Institute has been established on the same principles as the Greenwich Royal Naval College, for the benefit of officers of higher rank than cadet. Officers as high as the grade of Captain are admitted for a course of two years. By this means the standard of general efficiency is raised. Officers receive instruction in all branches of their profession.

The men of the fleet are divided into two divisions, one being stationed at Kiel and the other at Wilhelmshaven. Each division is subdivided into two classes. To pass from the second to the first class, good conduct, a service at sea of 48 months, and a certificate of complete instruction is required. The men of the first class receive a higher pay and form the body of the petty officers of the fleet.

Firemen and coal-heavers may, by proper application, pass through the grades of Machinist to the Corps of Engineer Machinists. In general the Machinists are all drawn from apprentices of that class.

The Germans are just commencing the introduction of permanent foreign squadrons.

HOLLAND.

The King of Holland is Commander-in-Chief of the Dutch Navy, the Crown Prince being Rear-Admiral and Chief of Staff. The navy is represented in the Cabinet by a civilian Minister of Marine, the central control being divided into sections and bureaus in a similar manner to that of other European nations. The general administration is centralized at four dock-yard stations—Amsterdam, Willemsoord, Hellevoetsluis, and Fijenoord—Amsterdam being the principal building-yard, and Fijenoord being the boiler and engine factory.

The grades of the Dutch Navy correspond with those of other services, the names of those of the executive corps being :

Luitenant-Admiraal.	Luitenant ter Zee 1 ^e klasse.
Vice-Admiraal.	Luitenant ter Zee 2 ^e klasse.
Schout-bij-Nacht.	{ 1 ^e klasse.
Kapitein ter Zee.	Adelborst { 2 ^e klasse.
Kapitein Luitenant ter Zee.	{ 3 ^e klasse.

In addition to the dock-yard at Amsterdam there is a Naval School and school-ships for the instruction of seamen and apprentices. At Hellevoetsluis there is a school for machinists. Great attention is paid in Holland to the development of torpedo instruction, a special corps of officers being drawn from the executive corps.

The cadre of the navy is filled from both volunteer and inscription methods, the latter resembling the French. This cadre amounts to 788 officers and 6426 men, not including 1000 native sailors and 600 marines in the East Indian local service.

In addition to this force there is a corps of Marine Infantry amounting to 52 officers and 2100 men.

There are two main divisions of the Dutch fleet, the first for home service and the second for East India service. The foreign squadrons are: 1. The Curaçoa station. 2d. The Surinam station. 3d. The East India fleet, which is divided into three main squadrons and four subordinate flotilla stations for the purpose of patrolling the coasts of Borneo, Sumatra, Java, and the Celebes Islands. Single cruisers are sent out at short periods to make cruises around the world, whilst a large division is kept ready for service in the shallow home waters.

ITALY.

The Italian Navy is represented in the Cabinet by a Minister of Marine. The central administration is divided into four main departments: 1st. The Personnel, under the control of a Secretary-General. 2d. The Matériel. 3d. Artillery and Torpedoes. 4th. Merchant Marine. There is an Admiralty Council for the general consideration of naval affairs, and a Scientific Bureau for the regulation of hydrographic affairs. The general arrangement of bureaus and superintendencies is similar to that of France, the whole central department being classed under the head of the General Staff.

For the general administration of affairs there are two dock-yard stations, Spezzia and Venice, with a third in process of formation at Tarenta.

The grades of the executive corps of the service are as follows:

Ammiraglio.
Vice-Ammiraglio.
Contro-Ammiraglio.
Capitano di Vascello.

Capitano di Fregato } 1^a classe.
 } 2^a classe.
Luogotenente di Vascello.
Sottotenente di Vascello.
Guardia Marina di 1^a classe.

All of the officers of this corps are drawn from the cadets of the Naval School, the course being four years of instruction. At present the cadets pass two years at Naples and two at Genoa, but it is the intention to establish a single Academy at Spezzia. There are three divisions of this corps: the active, the reserve or retired, and the officers at stationary residence, the latter being those who have waived promotion in consideration of having fixed duties at a seaport.

The Medical Corps is divided in the same manner as in other countries, the grades being:

Medico Ispettore.	Medico di Fregata, 2 ^a classe.
Medico Direttore.	Medico di Corvetta } 1 ^a classe. 2 ^a classe.
Medico di Vascello.	
Medico di Fregata, 1 ^a classe.	

The Technical Corps or Corps du Génie and the Commissary Corps are called the naval auxiliary corps.

GÉNIE.

Ispettore Generale.	Sotto Ingegnere di 1 ^a classe.
Direttore delle Costruzioni Navali.	Sotto Ingegnere di 2 ^a classe.
Ingegnere di 1 ^a classe.	Allieve Ingegnere (Cadet).
Ingegnere di 2 ^a classe.	

COMMISSARIAT.

Commissario Generale di 1 ^a classe.	Sotto Commissario di 3 ^a classe.
Commissario Generale di 2 ^a classe.	Sotto Commissario Aggiunto di 1 ^a classe.
Commissario di 1 ^a classe.	
Commissario di 2 ^a classe.	Sotto Commissario Aggiunto di 2 ^a classe.
Sotto Commissario di 1 ^a classe.	classe.
Sotto Commissario di 2 ^a classe.	Scrivano (Clerk).

These corps at present have relative military rank, but measures have been taken to give both a strictly civil organization, as it is considered that their duties are not compatible with military subordination.

The Machinists' Corps comprises but three grades—

Machinists.	First Chief Machinists.	Second Chief Machinists.
-------------	-------------------------	--------------------------

These grades are entirely recruited from the master-machinists or petty-officers grade of firemen. The grade of Chief Machinist, which was the highest until of late years, has been abolished, the duties being performed by officers of the Corps du Génie.

For the purpose of naval inscription the coast of Italy is divided into three departments, Spezzia, Naples, and Venice, subdivided into 22 districts, under controls similar to those of

France. All persons interested in a trade bearing upon navigation are liable for service on reaching the age of 20. They are then drawn into one of two divisions according to lot. The first is under obligations to render service for four years either at sea or in the dock-yards, at the end of which time they are granted a leave for six years, which, though not confining them to the country, may be rescinded at any time. At the end of the tenth year they pass into the Second Reserve, and are not liable except for extraordinary service. The second division receive at once a leave for ten years, at the end of which time they pass to the Second Reserve. There is also a system of voluntary enlistment and apprenticeship.

The Corps of Marine Infantry is recruited from the inscription in the same manner as the army. The headquarters are at Naples. This corps is made up of three battalions (one for each department), and the service is divided between the fleet and the dock-yards. There is no marine artillery in the Italian Navy.

The effective cadre of the Italian Navy is 1084 officers and 14,200 men, 90 officers of Marine Infantry and 3000 men. In comparison with the number of petty officers and men, there are fewer officers in this navy than in any in the world. The Italians have no cruising squadrons; single vessels do the foreign service, while the home service is confined to a single large squadron of evolutions.

JAPAN.

The navy is represented in the Council of State by a Minister and two Vice-Ministers, the central administration being carried on by a department constructed much in the same manner as in most European countries. The general administration is at present also almost entirely directed by the Navy Department. There is but one dock-yard at present completed and in operation, that of Yokoska in the Bay of Yeddo, in connection with which there is quite an extensive foundry at Yokohama.

At Nagasaki, although there is no especial dock-yard, there are repair-shops, a marine railway, and a partially completed dry-dock. At Kobi there are repair-shops, and an attempt has been made to establish a dock-yard at Tokio, but the shallow approaches render it of but little importance. Connected with the central administration there is a Hydrographic Office, Observatory, Naval School, and schools of instruction for Marine Infantry and Artillery. At present the navy is manned

entirely from volunteer enlistment, but a system of inscription is being perfected by which every person following a maritime trade will be liable for service between the ages of 18 and 45. The officers heretofore have for the greater part been educated in foreign naval schools, but at present the Naval Academy at Tokio is fully equal to the task of keeping the cadre full. This Naval School is modelled after the general European plan, the course being four years. Officers, as a rule, are appointed from the Noble class. The cadre of the navy at present is 300 officers, 5138 men, and 113 cadets. The grades and corps correspond closely with those of foreign powers. But very few foreign officers are now employed in the naval service, none at all in the fleet, their duties being confined to instructional and yard superintendence.

As yet the Japanese have not instituted any squadron service whatever, keeping nearly every vessel of their fleet in constant commission for instructional service. It is the intention, however, to establish both home and foreign squadron service as soon as the naval development will permit it to be done. The cadre of the Japanese Navy is 1180 officers and 4270 men.

NORWAY AND SWEDEN.

The navies of Norway and Sweden are distinct services, each having its own complete organization and administration. The Norwegian Navy is represented in the Cabinet by a Rear-Admiral, Chief of the Marine Department, who is assisted by a second Rear-Admiral, Chief of Staff. The central control at Stockholm is divided into three main sections, with Controllers at their heads, and subdivided into bureaus. The general administration is divided in control between two dock-yards, Christiania and Stockholm. There is also a Naval Academy, Hydrographic Office, and Observatory.

The Swedish Navy is represented in the Cabinet by a Minister of Marine, the central control having two main divisions, Chancellery and Command. There is in addition a Commander-in-Chief of Personnel, a Military Department, Construction Department, Commissariat Department, Pilotage Department, Naval School, and Hydrographic Office. The general administration is divided between the two naval stations of Carlskrona and Stockholm.

The personnel of both navies is recruited by voluntary enlistment, there being a special arrangement for conscription, in case of war in the maritime districts, of all persons between the ages of 22 and 35 years.

The grades of officers of the different corps are similar to those of other services, there being no grade of Admiral. The cadre of the two navies is :

SWEDEN.		NORWAY.	
Officers.....	518	Officers.....	104
Men.....	5,051	Men.....	550
Total.....			<u>6,223</u>

The Norwegian fleet is entirely confined to coast-defence vessels, no cruisers being now sent out. The Swedish fleet is well provided with cruisers, but there are no foreign squadrons, the foreign cruising being confined to single ships.

RUSSIA.

The Russian Navy is represented in the Council of State by the Admiral-General, a prince of the blood, who is Commander-in-Chief of the naval force. The head of the central administration is a Minister chosen from the list of Vice-Admirals. There are six sections or departments of control : 1st. The Chancellery, having charge of the expenditure of the Budget. 2d. The Department of the Personnel. 3d. The Hydrographic Department. 4th. The Technical Committee, divided into three sections—Construction of Vessels, Construction of Machinery, and Construction of Ordnance. 5th. The Supreme Naval Tribunal. 6th. The Direction of the Health Service. The general administration is divided between the naval stations of St. Petersburg, Sebastopol, Odessa, and the naval stations of the Caspian and Aral seas and Petropaulovsk on the Amoor River.

The personnel of the Russian Navy is recruited by inscription throughout the maritime districts, the inscription carrying with it certain benefits to the seafaring population, as in other countries. There are two divisions, active and reserve, the time of service being seven years in the active division and three in the reserve. The grades correspond with those of other navies. The effective strength is 4219 officers and 26,683 men.

The fleet is divided into five divisions with squadron subdivisions : 1st. The Baltic Fleet, divided into the Squadron of Evolutions, Division of School-ships, Lighthouse and Survey Squadrons, and Cruisers, the latter being engaged in long foreign cruises independently. 2d. Black Sea Fleet, Division of School-ships, Coast Guard-ships, Lighthouse Service, Hydrographic Service, Port Guard-ships, and Cruisers confined to the Black and Mediterranean seas. 3d. The Caspian Flotilla.

4th. The Siberian Flotilla. 5th. All vessels in course of construction at St. Petersburg or Odessa.

SPAIN.

The Minister of Marine is invariably chosen from the grades of Vice or Rear Admiral, having an officer of one of these grades as an Assistant Secretary and Chief of Staff. The affairs of the Ministry are controlled by bureaus and sections, with special committees for the regulation of certain special affairs. For the immediate superintendence of the naval administration the Spanish coast is divided into three departments, each commanded by an officer of high rank. The headquarters of the Department of the East are at Cartagena, those of the South at Cadiz, and those of the North at Ferrol; the Eastern Department including the Balearic Isles, and the Southern the Canaries. Cuba and Porto Rico form a fourth department, with headquarters at Havana; and the Philippine Islands a fifth, with headquarters at Manila. The Commander-in-Chief of the department is also in command of the fleet at the station.

For the purposes of naval inscription the departments are subdivided into provinces and districts, there being in all 110 districts, each of which is in charge of a naval officer so far as marine inscription is concerned. The corps and grade divisions of the active personnel correspond with those of other nations, the grades of the executive corps being as follows:

Almirante.	Teniente de Navio	} 1 ^a cl. } 2 ^a cl.
Vice-Almirante.	Alferece de Navio.	
Gefe de Escuadra.	Guardia Marina.	
Capitan de Navio.		
Capitan de Fregata.		

The grades of the Medical Corps are:

Medical Inspector.	First Surgeon.
Medical Sub-Inspector.	Second Surgeon.
Surgeon-Major.	

The grades of the Commissary Corps are:

Superintendent.	First Asst. Commissary.
Purveyor	Second Asst. Commissary.
} (1st class). } (2d class).	Third Asst. Commissary.
	Supernumeraries.
Commissary	
} (1st class). } (2d class).	

Chaplains have their ecclesiastical rank, and also a naval grade:

Sub Vicar-General.	Second Chaplain.
First Chaplain.	Sacristan (lay official).
	Chorister (lay official).

The Technical Corps embraces in one body the ship and engine constructors, called Engineers of the Fleet, and having the grades of—

General Officer.	Frigate Captain.
Brigadier.	Lieutenant.
Ship-of-the-Line Captain.	Ensign.

For service in working engines aboard ship there is a corps of machinists:

First Machinists	{ 1st class.	Third Machinists.
	{ 2d class.	Fourth Machinists.
Second Machinists.		Assistant Machinists.

The total active personnel of the fleet is 1792 officers (exclusive of Midshipmen, Chaplains, and the Technical Corps) and 14,000 men.

In addition to this cadre, there is a corps of Marine Artillery (Technical).

1 General Officer.	16 Captains.
3 Colonels.	20 Lieutenants.
7 Lieutenant-Colonels.	

And a corps of Marine Infantry which is divided into two half brigades of two battalions each, besides two companies of native infantry at the Philippines. The strength of this corps is 170 officers and 6256 men, making a grand total of 1962 officers and 20,256 men.

For the administration of justice each department has a district court, the maritime superior court being at Madrid.

The Naval Academy, situated at Ferrol, furnishes all the officers of the executive corps of the service. The age of entrance to the Academy is between 12 and 14 years, the length of the course at the school being two years and a half. At the expiration of this time they pass to a school-ship as second-class midshipmen, where they remain one or two years according to the needs of the cadre, when they pass to active service as midshipmen of the first-class, and after one year are commissioned Ensigns (Alfarece).

There are special schools under naval control for the education of pilots of the merchant service, another school for machinists, and an academy for the Artillery and Technical Corps.

At Madrid there is a Hydrographic Bureau and a Naval Museum, and at San Fernando a Naval Observatory.

The Spanish have five squadron cruising-grounds: the Mediterranean, South American, West Indian, Asiatic, and Atlantic, and a small African station limited to the Spanish possessions in the Gulf of Guinea.

At each of the prominent ports both of the home and colonial coasts there is a naval control under the superintendence of a Captain of the Port.

Promotion in all grades of the service except to that of Rear-Admiral is by seniority. Rear-Admirals are appointed by choice from the list of Line-Ship Captains. All persons in the maritime districts who follow a calling connected in any way with the sea are subject to the inscription, and none but those who are inscribed can engage in fishery or work upon the wharves or piers. The term of service is four years in the active and four in the reserve division. Each department has a separate school-ship and divisional formation, so that those persons who are inscribed are seldom removed from their immediate homes except for short cruises. There is a system of voluntary enlistment by which the main part of the active cadre is kept constantly full. In Spain as in Italy the merchant service is entirely under the control of the navy. In the head-quarter ports of Spain, unlike those of other nations, the Commander-in-Chief has no flag-ship and does not display a broad pennant. Flag-ships represent strictly the commands afloat. This is a point of importance, as all ports visited by foreign men-of-war have a commanding naval authority of high rank, although there is no visible sign of such command.

TURKEY.

The navy is represented in the Cabinet by a Minister of Marine and in the Divan or Chancellery by an Assistant Secretary. For the central administration there is an Admiralty Council composed of Admirals and General Officers. The service is divided into four sections: 1st. Personnel. 2d. Matériel. 3d. Naval Constructions. 4th. Health. Each control has an Admiral at its head with the title of Director. The Minister has the supreme control of all naval affairs.

The fleet is recruited by inscription from the maritime districts, there being no reserve proper. The length of service is eight years.

The personnel of the navy consists of 1868 officers and 30,000 men, in addition to which there is a corps of marine infantry numbering 91 officers and 4500 men. The grades

correspond with those of other countries except that there is no grade of Admiral, and the grade of Ensign corresponds closely with that of Midshipman in other services, there being no Naval Academy and no grade of Cadet.

UNITED STATES.

The navy is represented in the Cabinet by a Secretary of the Navy, who is invariably a civilian; the President of the United States being the Commander-in-Chief, but without any immediate naval executive. The central control is divided into eight bureaus under the superintendence of naval officers of the different corps having the grade of Commodore: 1st. Bureau of Navigation, subdivided into the Office of Detail, having charge of the personnel of the fleet; Hydrographic Office, Naval Observatory, and Signal Office. 2d. Bureau of Ordnance, having charge of all artillery matters, including the torpedo station at Newport. 3d. Bureau of Equipment and Recruiting, having charge of outfits, recruiting, and the apprentice service. 4th. Bureau of Yards and Docks, having charge of all naval grounds and buildings. 5th. Bureau of Medicine and Surgery. 6th. Bureau of Provisions and Clothing, having charge of supplies and accounts. 7th. Bureau of Steam Engineering, having charge of the design and care of engines and boilers. 8th. Bureau of Construction and Repair. The Naval Academy is under an independent control attached directly to the superintendence of the Secretary of the Navy.

The general administration is divided into departments at the different dock-yards, each department corresponding with a bureau of the central control, and all under the superintendence of a commandant who is an officer of the executive corps having the grade of Commodore. There are no naval maritime districts in the United States, naval authority being limited strictly to the dock-yard government. There are seven dock-yards: Portsmouth (New Hampshire), Charlestown (Massachusetts), Brooklyn (New York), League Island (Pennsylvania), Norfolk (Virginia), Pensacola (Florida), and Mare Island (California). In addition to these there are three subordinate stations for coaling, recruiting, and repairing: New London (Connecticut), Port Royal (South Carolina), and Key West (Florida). The Coast Survey and Lighthouse establishments, although not under the control of the Navy Department, employ naval officers almost exclusively.

Officers of the Executive and Engineer Corps are drawn exclusively from graduates of the Naval Academy. The

ASSIMILATED GRADES OF THE CORPS OF THE UNITED STATES NAVY.

EXECUTIVE CORPS.	MEDICAL CORPS.	PAY CORPS.	ENGINEER CORPS.	CONSTRUCTORS' CORPS.	CORPS OF CHAPLAINS AND PROFESSORS.
Admiral..... } Honor'y. Vice-Admiral }					
Rear-Admiral.....					
Commodore	Surgeon-General	Paymaster-General	Engineer-in-Chief.....	Chief Constructor.	Officers of these corps bear the names of Chaplain and Professor, the grades being from Captain to Lieutenant, except that there is no grade to correspond with Lieut.-Commander.
Captain.....	Medical Director.....	Pay Director.....			
Commander.....	Medical Inspector.....	Pay Inspector.....	} Chief Engineer.....	Naval Constructor	
Lieutenant-Commander.	Surgeon.....	Paymaster.....			
Lieutenant.....	Passed Asst. Surgeon..	Passed Asst. Paymaster.	Passed Asst. Engineer.	} Assistant Naval Constructor.	
Master.....	" " "	" " "	" " "		
Ensign.....	Assistant Surgeon.....	Assistant Paymaster.....	Assistant Engineer.		
Midshipman.					
Cadet Midshipman.....			Cadet Engineer.		
Cadet.....			Engineer Cadet.		

other corps are drawn from civil life. Promotion is strictly by seniority in all grades. All officers except those in the Constructors' and Professors' Corps are obliged to pass a rigid examination in being promoted from one grade to another. The course of study at the Naval Academy is four years for both executive and engineer officers; the cadet then passes into the fleet for a period of two years for active service, at the end of which time he is eligible for promotion to the next grade. On reaching the age of 62 years or after 45 years of service, officers are retired from the active list. Officers failing twice in examination for promotion may be retired as mentally unqualified for active service.

In addition to these grades, in the regular line of promotion there are five subordinate; grades of what are called Warrant Officers namely, Boatswain, Gunner, Carpenter, Sailmaker, and Mate.

The cadre of the active list of the navy is 1678 officers, 7500 men, and 700 apprentices.

There is also a corps of Marine Infantry numbering 75 officers and 2500 men.

The method of enlistment is entirely voluntary, for periods of three years, with special inducements for re-enlistment. There is no reserve division of the service, the active cadre representing the entire disposable force. Apprentices are enlisted between the ages of 14 and 18, with obligatory service until they reach the age of 21. They are first put in training-ships, where they remain between two and three years, entering the fleet as soon as they are considered fully instructed. After entering the fleet they are eligible to advancement as seamen and petty officers.

The cruising fleet is divided into five squadrons—the North Atlantic, South Atlantic, European, Asiatic, and Pacific—with one vessel in constant commission cruising in the chain of great lakes on the northern boundary, and one in the Rio Grande on the Mexican boundary. Four ships (one steam frigate and three sailing corvettes) are also kept constantly in commission as cruisers with apprentices for instruction. The iron-clad fleet is kept in partial commission ready for service, but in fresh water, in order to prevent the fouling and corrosion of the bottoms.



DENMARK.

The navy is represented in the Cabinet by a Minister of Marine, the central administration having an officer of high rank at its head, bearing the title of Director-General. The control is divided into three sections: 1st. The Admiralty. 2d. The Commissariat. 3d. The Judiciary. The Admiralty is subdivided into departments of Personnel, Matériel, and Health. Grades of personnel are similar to those of other navies. The cadre of the navy is 120 officers and 2761 men. There are no foreign cruisers.

GREECE.

The navy is represented in the Cabinet by a Minister of Marine, and the central control is superintended by an Admiral bearing the title of Inspector-General of the Fleet. The grades of officers correspond to those of other navies. The cadre of the personnel of the fleet is 71 officers and 581 men.

PERU.

The navy is not a separate organization, being represented in the Cabinet by a Minister of War, and having at its head an Admiral Commander-in-Chief. The control is confined to the port of Callao, where in time of peace the fleet is kept almost permanently at anchor. Administration and cadre unknown.

PORTUGAL.

The navy of Portugal is represented in the Cabinet by a Minister of Marine, who has also the Colonial Service under his jurisdiction, as with the French. The King of Portugal is Commander-in-Chief of the navy (taking the rank of Admiral amongst his titles), the immediate executive control of the naval personnel being superintended by a Vice-Admiral Commander-in-Chief, assisted by a Board of Admiralty. Both the central and general controls are at Lisbon, where is situated the only dock-yard. The grades of the personnel of the Portuguese Navy are similar to those of other nations. The cadre is 393 officers and 3200 men.

The Portuguese fleet is distributed in squadrons at the different colonial stations, although they do but little cruising. A squadron is kept in commission at Lisbon, cruising to Madeira and the African coast in the fall of the year. In addition to the dock-yard there is a Naval School and Observatory, and a small repair-yard at Oporto. The navy is recruited by voluntary enlistment.

NAVAL BUDGETS.

TOGETHER WITH THE PROPORTION WHICH THEY BEAR TO THE ENTIRE EXPENSES OF THE GOVERNMENT FOR THE CORRESPONDING YEAR. (IN DOLLARS OF AMERICAN COIN.)

	AUSTRIA.		BRAZIL.		DENMARK.		ENGLAND.	
1875...	\$5,038,980	$\frac{1}{11}$	\$10,737,267	$\frac{1}{2}$	\$1,258,180	$\frac{1}{10}$	\$53,447,020	$\frac{1}{2}$
1876...	4,705,090	$\frac{1}{12}$	11,992,977	$\frac{1}{2}$	1,193,700	$\frac{1}{12}$	55,317,245	$\frac{1}{2}$
1877...	4,705,090	$\frac{1}{12}$	5,467,730	$\frac{1}{11}$	1,193,700	$\frac{1}{12}$	56,821,915	$\frac{1}{2}$
1878...	4,805,480	$\frac{1}{12}$	5,467,730	$\frac{1}{11}$	1,323,308	$\frac{1}{2}$	54,892,960	$\frac{1}{11}$
1879...	4,354,900	$\frac{1}{10}$	6,138,301	$\frac{1}{2}$	1,589,418	$\frac{1}{2}$	59,811,580	$\frac{1}{10}$
	FRANCE.		GERMANY.		GREECE.		HOLLAND.	
1875...	\$27,277,496	$\frac{1}{19}$	\$4,511,955	$\frac{1}{12}$	\$360,070	$\frac{1}{12}$	\$2,617,994	$\frac{1}{2}$
1876...	27,277,496	$\frac{1}{19}$	5,267,120	$\frac{1}{19}$	391,978	$\frac{1}{10}$	2,726,517	$\frac{1}{2}$
1877...	73,253,303	$\frac{1}{2}$	7,144,250	$\frac{1}{19}$	422,941	$\frac{1}{10}$	2,781,076	$\frac{1}{2}$
1878...	32,592,387	$\frac{1}{17}$	14,672,671	$\frac{1}{2}$	426,941	$\frac{1}{10}$	2,753,677	$\frac{1}{2}$
1879...	32,183,416	$\frac{1}{17}$	11,434,197	$\frac{1}{12}$	749,731	$\frac{1}{10}$	2,627,732	$\frac{1}{2}$
	ITALY.		JAPAN.		NORWAY AND SWEDEN.		PORTUGAL.	
1875...	\$7,468,184	$\frac{1}{19}$	\$1,800,000	$\frac{1}{10}$	\$1,526,275	$\frac{1}{18}$	\$1,468,800	$\frac{1}{10}$
1876...	7,543,390	$\frac{1}{15}$	2,700,000	$\frac{1}{15}$	1,725,350	$\frac{1}{17}$	1,554,406	$\frac{1}{10}$
1877...	8,326,156	$\frac{1}{11}$	3,549,700	$\frac{1}{10}$	2,204,040	$\frac{1}{10}$	1,878,665	$\frac{1}{17}$
1878...	8,870,282	$\frac{1}{12}$	3,217,500	$\frac{1}{17}$	1,944,875	$\frac{1}{10}$	1,876,264	$\frac{1}{17}$
1879...	8,864,877	$\frac{1}{12}$	2,636,300	$\frac{1}{17}$	1,896,750	$\frac{1}{17}$	1,952,837	$\frac{1}{10}$
	RUSSIA.		SPAIN.		TURKEY.		UNITED STATES.	
1875...	\$20,084,813	$\frac{1}{12}$	\$6,560,355	$\frac{1}{18}$	\$2,600,000	$\frac{1}{18}$	\$23,000,000	$\frac{1}{11}$
1876...	20,030,705	$\frac{1}{13}$	6,536,235	$\frac{1}{18}$	3,200,000	$\frac{1}{10}$	21,497,626	$\frac{1}{11}$
1877...	19,895,028	$\frac{1}{13}$	5,739,806	$\frac{1}{13}$	3,200,000	$\frac{1}{10}$	18,963,310	$\frac{1}{10}$
1878...	18,839,706	$\frac{1}{15}$	5,196,955	$\frac{1}{18}$	2,560,000	$\frac{1}{12}$	14,959,935	$\frac{1}{17}$
1879...	20,956,465	$\frac{1}{14}$	5,196,955	$\frac{1}{18}$	2,560,000	$\frac{1}{12}$	17,365,301	$\frac{1}{11}$

KRUPP'S CAST-STEEL COAST AND NAVAL GUNS OF 30 AND 35 CALIBRES LENGTH.

	12 cm.		15 cm.		17 cm.			
	Of 30 calibres length.	Of 35 calibres length.	Of 30 calibres length.	Of 35 calibres length.	Of 30 calibres length.	Of 35 calibres length.		
Calibre..... mm	120	120	149.1	149.1	172.6	172.6		
Total length..... "	3600	4200	4470	5220	5180	6040		
Length of bore..... "	3275	3875	4050	4800	4695	5555		
Weight of gun..... kg	2015	2260	4200	4750	6700	7500		
Weight of steel shell..... "	20	20	38.5	38.5	60	60		
Battering charge..... "	9	9	17	17	26	26		
Muzzle-velocity..... m	575	605	575	605	575	605		
Energy	total..... mt	337.03	373.12	649	718	1011.1	1119.4	
	per cm. of circumference... "	8.94	9.90	13.85	15.34	18.18	20.13	
	per cm ² . of cross section.... "	2.98	3.30	3.71	4.1	4.32	4.78	
	per 1000 kg of weight of gun. "	167.2	165	155	151	151	149	
Remaining velocity of steel shell	of 500 m..... m	516.5	543	526.7	554	533.3	560.5	
	" 1000 "..... "	464.5	487.5	482	506.7	494.5	520	
	" 1500 "..... "	418.5	438.5	442	464	458.6	482	
	" 2000 "..... "	380	397	406.7	426.3	425.5	447	
	" 2500 "..... "	348.5	362	375	393	397	415.8	
Energy	total	" 500 "..... mt	271.9	300.5	544.4	602.3	869.7	960.8
		" 1000 "..... "	219.9	242.2	455.9	503.8	747.8	826.9
		" 1500 "..... "	178.5	196	383.4	422.5	643.1	710.5
		" 2000 "..... "	147.1	160.7	324.59	356.6	553.7	611.04
		" 2500 "..... "	123.8	133.6	276	303.1	482	528.7
	per cm. of circumference	" 500 "..... "	7.21	7.97	11.62	12.86	15.65	17.28
		" 1000 "..... "	5.83	6.43	9.73	10.75	13.45	14.87
		" 1500 "..... "	4.74	5.20	8.18	9.02	11.57	12.78
		" 2000 "..... "	3.90	4.26	6.93	7.61	9.96	10.99
		" 2500 "..... "	3.28	3.54	5.89	6.47	8.67	9.51
per cm ² of cross section	" 500 "..... "	2.40	2.66	3.12	3.45	3.72	4.11	
	" 1000 "..... "	1.94	2.14	2.61	2.89	3.20	3.53	
	" 1500 "..... "	1.58	1.73	2.20	2.42	2.75	3.04	
	" 2000 "..... "	1.30	1.42	1.86	2.04	2.36	2.61	
	" 2500 "..... "	1.09	1.18	1.58	1.74	2.06	2.26	
When striking at right angles the steel shell penetrates a wrought Iron-Plate of the following thickness	at the muzzle at a distance. cm	23.5	25.5	29.5	31.5	34	37	
	of 500 m " "	20	22	26	28	30.5	33	
	" 1000 " " "	17	18.5	22.5	24.5	27	29.5	
	" 1500 " " "	15	16	20	21.5	24	26	
	" 2000 " " "	13	14	17.5	18.5	21.5	23.5	
Or two plates of the following thickness	at the muzzle at a distance. cm	10 + 18	10 + 20	15 + 20	15 + 22.5	18 + 22	18 + 25.5	
	of 500 m " "	10 + 14	10 + 16	15 + 16	15 + 18	18 + 18	18 + 21	
	" 1000 " " "	10 + 11	10 + 12.5	15 + 12	15 + 14	18 + 14.5	18 + 17	
	" 1500 " " "	10 + 8	10 + 9	15 + 8	15 + 10	18 + 11	18 + 13	
	" 2000 " " "	10 + 5	10 + 6.5	15 + 5	15 + 7	18 + 7	18 + 9.5	
	" 2500 " " "	10 + 3	10 + 4	15 + 1	15 + 4	18 + 3.5	18 + 6	

KRUPP'S CAST-STEEL COAST AND NAVAL GUNS OF 30 AND 35 CALIBRES
 LENGTH—(CONTINUED.)

	20 cm.		21 cm.		24 cm.				
	Of 30 calibres length.	Of 35 calibres length.	Of 30 calibres length.	Of 35 calibres length.	Of 30 calibres length.	Of 35 calibres length.			
Calibre	mm	200	200	209.3	209.3	240	240		
Total length	"	6000	7000	6280	7390	7200	8400		
Length of bore	"	5425	6425	5670	6720	6480	7680		
Weight of gun	kg	11000	12500	12500	14000	19000	21500		
Weight of steel shell	"	95	95	108	108	160	160		
Battering charge	"	40	40	45	45	65	65		
Muzzle-velocity	m	575	605	575	605	575	605		
Energy {	total	mt	1600	1773	1820	2014.8	2700	2985	
	per cm. of circumference...	"	25.5	28.25	27.68	30.64	35.8	39.6	
	per cm ² . of cross section....	"	5.1	5.65	5.29	5.86	5.96	6.6	
	per 1000 kg of weight of gun. "	"	145.5	142	145.6	144	142	139	
Remaining velocity of steel shell {	of 500 m	m	539.5	567.5	541	568.8	544	572.5	
	" 1000 "	"	505	532	509	535.2	514.7	541.5	
	" 1500 "	"	474.5	498.7	479	503.3	487	512.6	
	" 2000 "	"	445.5	468	451.5	473.8	461	485	
	" 2500 "	"	419	439.7	426.4	447	437.5	459.3	
Energy {	total {	" 500 "	mt	1409.4	1559.5	1611.1	1780.9	2415	2673
		" 1000 "	"	1237.4	1370.5	1426.1	1576.7	2165	2391.4
		" 1500 "	"	1090.3	1204.3	1263	1394.4	1934.2	2143
		" 2000 "	"	961.1	1060.6	1122.2	1235.7	1732	1918.4
		" 2500 "	"	850.1	936.2	1000.8	1099.8	1561	1720.5
	per cm. of circumference {	" 500 "	"	22.43	24.82	24.50	27.09	32.01	35.45
		" 1000 "	"	19.69	21.81	21.69	23.98	28.65	31.72
		" 1500 "	"	17.35	19.17	19.21	21.26	25.65	28.42
		" 2000 "	"	15.30	16.88	17.07	18.79	22.99	25.44
		" 2500 "	"	13.53	14.90	15.22	16.73	20.71	22.82
per cm ² of cross section {	" 500 "	"	4.49	4.96	4.68	5.18	5.34	5.91	
	" 1000 "	"	3.94	4.36	4.15	4.58	4.78	5.29	
	" 1500 "	"	3.47	3.83	3.67	4.05	4.28	4.74	
	" 2000 "	"	3.06	3.38	3.26	3.59	3.83	4.24	
	" 2500 "	"	2.71	2.98	2.91	3.20	3.45	3.80	
When striking at right angles the steel shell penetrates a wrought Iron-Plate of the following thickness {	at the muzzle at a distance.cm		40.5	43.5	42	45	47.5	51	
	of 500 m " "	"	36.5	39.5	38	41	43.5	47	
	" 1000 " " "	"	33	36	35	37.5	40	43.5	
	" 1500 " " "	"	30	32.5	31.5	34	37	40	
	" 2000 " " "	"	27.5	29.5	29	31	34	36.5	
Or two plates of the following thickness {	at the muzzle at a distance.cm		25 + 23	25 + 26.5	25 + 24.5	25 + 28.5	30 + 26.5	30 + 31	
	of 500 m " "	"	25 + 18.5	25 + 22	25 + 20	25 + 23.5	30 + 21.5	30 + 26	
	" 1000 " " "	"	25 + 14	25 + 18	25 + 16	25 + 19.5	30 + 17.5	30 + 21.5	
	" 1500 " " "	"	25 + 10	25 + 13	25 + 12	25 + 15	30 + 13	30 + 17	
	" 2000 " " "	"	25 + 5.5	25 + 9	25 + 8	25 + 11	30 + 8.5	30 + 12.5	
" 2500 " " "	"	25 + 0	25 + 4.5	25 + 4	25 + 7	30 + 3.5	30 + 8		

KRUPP'S CAST-STEEL COAST AND NAVAL GUNS OF 30 AND 35 CALIBRES LENGTH—(CONTINUED.)

	26 cm.		28 cm.		30½ cm.		
	Of 30 calibres length.	Of 35 calibres length.	Of 30 calibres length.	Of 35 calibres length.	Of 30 calibres length.	Of 35 calibres length.	
Calibre	260	260	280	280	305	305	
Total length.....	7800	9100	8400	9800	9150	10700	
Length of bore.....	7020	8320	7560	8900	8220	9770	
Weight of gun.....	25000	28100	33200	37300	42900	48400	
Weight of steel shell.....	205	205	255	255	329	329	
Battering charge.....	83	83	103	103	132	132	
Muzzle-velocity.....	575	605	575	605	575	605	
Energy	total.....	3454.5	3824.4	4297	4757.3	5544.2	6137.9
	per cm. of circumference....	42.29	46.82	48.85	54.08	57.86	64.05
	per cm ² . of cross section....	6.51	7.20	6.98	7.73	7.59	8.40
	per 1000 kg of weight of gun. "	138	136	129.5	127.5	129	127
Remaining velocity of steel shell	of 500 m.....	546.8	575.3	548.6	577.3	550.7	579.4
	" 1000 ".....	519.9	547	523.5	550.8	527.4	554.9
	" 1500 ".....	494.4	520.1	499.4	525.5	505.1	531.5
	" 2000 ".....	470.1	494.6	476.5	501.4	483.8	509
	" 2500 ".....	447	470.3	451.7	478.4	463.3	487.5
Energy	total	3123.5	3458	3912	4390.8	5085.3	5629.9
	" 1000 ".....	2824.1	3126.5	3561.2	3942.5	4664.5	5164
	" 1500 ".....	2553.5	2826.8	3242	3589.1	4278.5	4736.7
	" 2000 ".....	2308.7	2556	2951.3	3267.3	3924.4	4334.7
	" 2500 ".....	2087.5	2311.3	2686.7	2974.4	3599.6	3985
	per cm. of circumference	38.24	42.33	44.47	49.23	53.70	58.75
	" 1000 ".....	34.57	38.28	40.48	44.82	48.68	53.89
	" 1500 ".....	31.26	34.61	36.85	40.80	44.65	49.43
	" 2000 ".....	28.26	31.29	33.55	37.14	40.96	45.34
	" 2500 ".....	25.56	28.29	30.62	33.81	37.57	41.59
per cm ² of cross section	5.88	6.51	6.35	7.03	6.96	7.71	
" 1000 ".....	5.32	5.89	5.78	6.40	6.38	7.07	
" 1500 ".....	4.81	5.32	5.27	5.83	5.86	6.48	
" 2000 ".....	4.35	4.81	4.79	5.31	5.37	5.95	
" 2500 ".....	3.93	4.35	4.37	4.83	4.82	5.45	
When striking at right angles the steel shell penetrates a wrought Iron-Plate of the following thickness	at the muzzle at a distance.cm	51.5	56	55.5	60	60.5	65
	of 500 m " " "	48	51.5	51.5	56	56.5	61
	" 1000 " " " "	44.5	48	48	52	53	56.5
	" 1500 " " " "	41.5	44.5	44.5	48.5	49.5	53.5
	" 2000 " " " "	38	41.5	41.5	45	46.5	50
	" 2500 " " " "	35.5	38	38.5	42	43	47
Or two plates of the following thickness	at the muzzle at a distance.cm	35 + 26.5	35 + 31.5	38 + 26.5	38 + 32.5	40 + 34	40 + 37
	of 500 m " " "	35 + 21.5	35 + 26.5	38 + 23	38 + 27	40 + 26.5	40 + 32.5
	" 1000 " " " "	35 + 17	35 + 21.5	38 + 18	38 + 23.5	40 + 21.5	40 + 27.5
	" 1500 " " " "	35 + 12.5	35 + 17	38 + 13	38 + 18.5	40 + 17	40 + 23
	" 2000 " " " "	35 + 7.5	35 + 12.5	38 + 8	38 + 13.5	40 + 13	40 + 18
	" 2500 " " " "	35 + 2	35 + 7.5	38 + 2.5	38 + 8.5	40 + 7	40 + 13.5

KRUPP'S CAST-STEEL COAST AND NAVAL GUNS OF 30 AND 35 CALIBRES
 LENGTH—(CONTINUED.)

	35½ cm.		40 cm.		
	Of 30 calibres length.	Of 35 calibres length.	Of 30 calibres length.	Of 35 calibres length.	
Calibre	355	355	400	400	
Total length	10650	12400	12000	14000	
Length of bore	9510	11260	10700	12700	
Weight of gun	68000	76500	97200	109500	
Weight of steel shell	525	525	740	740	
Battering charge	210	210	295	295	
Muzzle-velocity	575	605	575	605	
Energy { total	8847	9794.5	12470	13805	
Energy { per cm. of circumference	79.33	87.82	99.23	109.86	
Energy { per cm ² . of cross section	8.94	9.60	9.92	10.99	
Energy { per 1000 kg of weight of gun	129	127	138.5	126.5	
Remaining velocity of steel shell {	of 500 m	554.3	583.2	556.3	585.4
	" 1000 "	534.3	562.2	538.2	566.3
	" 1500 "	515.1	542	530.8	547.9
	" 2000 "	496.6	522.5	503.8	530.1
	" 2500 "	478.7	503.6	487.5	512.9
Energy {	total { " 500 "	8221.5	9101.8	11673	12923
	total { " 1000 "	7640.2	8458.2	10927	12097
	total { " 1500 "	7099.8	7860.2	10228	11323
	total { " 2000 "	6598	7304.3	9574.6	10599
	total { " 2500 "	6131.3	6787.8	8962.6	9922.3
	per cm. of circumference { " 500 "	73.72	81.61	92.89	102.84
	per cm. of circumference { " 1000 "	68.50	75.84	86.95	96.26
	per cm. of circumference { " 1500 "	63.66	70.48	81.40	90.11
	per cm. of circumference { " 2000 "	59.16	65.49	76.19	84.35
	per cm. of circumference { " 2500 "	54.97	60.86	71.32	78.96
Energy {	per cm ² of cross section { " 500 "	8.31	9.20	9.29	10.28
	per cm ² of cross section { " 1000 "	7.72	8.55	8.70	9.63
	per cm ² of cross section { " 1500 "	7.17	7.94	8.14	9.01
	per cm ² of cross section { " 2000 "	6.67	7.38	7.62	8.44
	per cm ² of cross section { " 2500 "	6.19	6.86	7.13	7.90
When striking at right angles the steel shell penetrates a wrought Iron-Plate of the following thickness {	at the muzzle at a distance....cm	70.5	76.5	79	85.5
	of 500 m " " " "	67	72.5	75	81
	" 1000 " " " "	63.5	68.5	71.5	77
	" 1500 " " " "	60	64.5	68	73
	" 2000 " " " "	57	61	65	70
	" 2500 " " " "	54	58	62	66.5
Or two plates of the following thickness {	at the muzzle at a distance....cm	50 + 34	50 + 40.5	60 + 32.5	60 + 41
	of 500 m " " " "	50 + 29	50 + 35.5	60 + 27.5	60 + 35.5
	" 1000 " " " "	50 + 24	50 + 30.5	60 + 22.5	60 + 30.5
	" 1500 " " " "	50 + 19	50 + 26	60 + 17.5	60 + 25.5
	" 2000 " " " "	50 + 14.5	50 + 21	60 + 12	60 + 20
	" 2500 " " " "	50 + 9	50 + 16	60 + 5.5	60 + 15.

INDEX.

	PAGE
Alabama and Hatteras, duel.....	170
Kearsarge, ".....	171
Architectural Development—Unarmored fleets.....	361
Conditions affecting English.....	361
French.....	362
United States.....	362
Chart of.....	372
Armored fleets.....	386
Argentine Confederation Fleets, Table of.....	3
Description of.....	4
Ordnance, Description of.....	180
Type of small-arms used.....	311
Personnel.....	399
Armor—Table of penetration of English guns.....	319
French ".....	321
German ".....	320
Krupp's new long guns.....	435
Application of.....	395
Armstrong Breech-loaders, Table of measurements of.....	182
Description of.....	193, 194
Muzzle-loaders, Description of.....	192-194
Projectiles.....	209
Fuses.....	211
Grooves.....	192
Assaults—Fort Sumter.....	160
Fisher.....	160
Corean Forts.....	161
Assimilated Rank—Grades of Austrian officers.....	402
Brazilian officers.....	406
English officers.....	410
French officers.....	416
United States officers.....	431
Atlanta and Weehawken, duel.....	171
Austrian Fleets, Armored, Table of.....	5
General-service, Table of.....	9
Armored vessels, Ratios of elements.....	390
Ordnance, Table of.....	177
Description of.....	180
Types and calibres of.....	317
Personnel, Departmental organization of.....	400
Names of grades.....	400
Inscription and instruction.....	401
Relative rank.....	402
Cadre.....	400

	PAGE
Austrian cruising stations.....	405
Budgets.....	434
Bellerophon, Construction of iron hull of.....	382
Boat-carriages—English.....	197
French.....	235
German.....	263
United States.....	289
Bombardments—Callao.....	149
Danube Earthworks.....	149
Fort Darling.....	142
Donelson.....	142
Fisher.....	147
Henry.....	140
Hindman.....	144
Jackson and St. Philip.....	152
McAllister.....	147
Sumter.....	151
Wagner.....	146
Grand Gulf Earthworks.....	144
Hateras Inlet.....	139
Hilton Head.....	140
Kagosima.....	146
Roanoke Island.....	141
Simonoseki.....	145
Bouvet and Meteor, duel.....	172
Brazil, Construction of iron hull of.....	380
Brazilian Fleet, Armored, Table of.....	10
Description of.....	11
Unarmored, Table of.....	12
Ordnance, Description of.....	180
Types and calibres of.....	317
Personnel, Departmental organization of.....	405
Grades and relative rank.....	406
Cadre.....	407
Cruising stations.....	407
Budget.....	434
Breech-loaders—Armstrong.....	193
French, model 1870.....	225
model 1864.....	228
Finspong.....	276
German.....	244
Krupp's new long guns, table of measurements.....	435
United States.....	285
Whitworth.....	218
Breech Mechanism—Armstrong, original.....	193
improved.....	195
French, model 1870.....	226
model 1864.....	229
Hotchkiss revolving cannon.....	306
Gatling machine-gun.....	309
Krupp cylindro-prismatic.....	246
Small-arms.....	311
United States.....	287
Whitworth.....	218
Brooks's torpedo for harbor defence.....	345
Brookwell broadside gun-carriage.....	250
Cadre—Argentine Navy.....	399
Austrian.....	400
Brazilian.....	407

	PAGE
Cadre—Chilian Navy	407
Danish	433
Dutch	422
English	411
French	417
German	419
Greek	433
Italian	424
Japanese	425
Norwegian	426
Portuguese Navy	433
Russian	426
Spanish	428
Swedish	426
Turkish	429
United States	432
Cartridges—English	207
French	236
Charleston blockaders, Dash at	166
Chart of architectural development	372
Chilian Fleet, Armored, Table of	13
Description of	13
General-service, Table of	13
Ordnance, Description of	181
Types and calibres of	317
Personnel, Departmental organization of	407
Cadre	407
Chinese Fleet, Table of	16
Description of	16
Ordnance, Description of	181
Types and calibres of	317
Personnel	408
Compressors—Elswick	201
Bow	202
English hydraulic	203-206
French friction	231
Brookwell	250
Vavasseur	220
German hydraulic	257-263
United States boat-carriage	289
central recoil-check	295
hydraulic	296
Ericsson's friction	296
turret-carriage	298
English wooden slide-carriage	196
German boat-carriage	264
Construction, Ship, Development of	373
Wooden	374
Diagonal	375
Composite	377
Iron	379
Iron sheathed with wood	384
Iron hull of Brazil	380
Warrior	381
Bellerophon	382
Hercules	383
Invincible	383
Gun—Palliser	217
Armstrong	192

	PAGE
Construction, Gun—Whitworth	218
Vavasseur	219
Woolwich	186
Krupp	244
Finspong	276
American smooth-bore	283
Uchatius	180
American converted	285
French	225
Cruising Stations, Squadron—Argentine	400
Austrian	405
Brazilian	407
Dutch	422
English	412
French	417
Italian	424
Russian	426
Spanish	429
United States	432
Dashes—Passes of the Mississippi	165
Vicksburg (Arkansas passing Farragut's fleet)	166
Charleston blockading fleet	166
Monitor and Merrimac	170
Alabama and Hatteras	170
Weehawken and Atlanta	171
Kearsarge and Alabama	171
Meteor and Bouvet	172
Denmark Fleet, Armored	17
General-service	18
Ordnance, Description of	181
Types and calibres of	317
Personnel, Departmental organization of	433
Budgets	434
Directing-bar Carriage—French	234
United States	293
Distinguishing marks of English projectiles	216
Distribution of armor	395
Elevating-gear—Woolwich rack and pinion	201
boat-gun	197
hydraulic	205
French	231, 233, 234
German rack and pinion	252
boat-gun	250
United States boat-gun	280
breech-loader	293
smooth-bore	293
Hotchkiss revolving cannon	306
Gatling machine-gun	308
English Fleet, Armored, Table of	20
Description of	23
Fast cruisers, Table of	36
Description of	42
General-service, Table of	48
Ordnance, Table of measurements of	182
Description of	186
Types and calibres of	317
Revolving turret	358
Conditions affecting architectural development	361
Ratios of elements of iron-clad vessels	390

	PAGE.
English Personnel—Departmental organization.....	408
Dock-yards	409
Enlistment.....	409
Grades and relative rank.....	410
Coast-guard	411
Cadre.....	411
Royal Naval College.....	411
Gunnery and torpedo instruction.....	411
Naval reserve.....	411
Probationary course of young officers.....	412
Indian navy	412
Cruising stations.....	412
Budgets	434
Ericsson—Torpedo vessel.....	398
Development of Monitor.....	386
Turret gun-carriage.....	298
Broadside slide-carriage.....	297
Revolving turret.....	357
Field-carriages—United States.....	289
English.....	196
French.....	236
German.....	264
Finspong breech-loader.....	276
Fleets—Architectural development of armored.....	389
unarmored.....	361
Argentine.....	3
Austrian.....	5
Brazilian.....	10
Chilian.....	13
Chinese.....	16
Danish.....	17
Dutch.....	84
English.....	20
French.....	51
German.....	73
Greek.....	82
Italian.....	90
Japanese.....	96
Norwegian.....	99
Peruvian.....	103
Portuguese.....	104
Russian.....	106
Spanish.....	116
Swedish.....	99
Turkish.....	121
United States.....	128
French Fleet, Armored, Table of.....	51
Description of.....	55
Rapid cruisers, Table of.....	62
Description of.....	65
General-service, Table of.....	70
Ordnance, Table of measurements of.....	221
Description of.....	225
Types and calibres of.....	317
Towing torpedo.....	333
Revolving turret.....	359
Barbette fixed turret.....	360
Conditions affecting architectural development.....	362
Ratio of elements of iron-clad vessels.....	390

	PAGE
French—Wooden hulls, superiority over English iron ones	392
Personnel—Departmental organization	412
Maritime prefectures	414
Enlistment and inscription	415
Grades and assimilated rank	416
Official reports	416
Promotion	417
Cadre	417
Cruising stations	417
Budgets	434
Fuses—Boxer time	211
Armstrong time	211
Pettman percussion	212
French percussion	238
time	238
German percussion	266
Krupp time	267
United States Navy time	302
Borrmann time	303
Boxer time	303
Schenkel percussion	304
Torpedo time	347
McEvoy's time	347
percussion	348
Hill's chemical	348
friction	348
sulphuric acid	349
Harvey's chemical	349
electric	349
Gas-checks—Woolwich projectile	210
French	227-229
Armstrong, original	194
improved	195
Broadwell	246-248
Gatling machine-gun	308
General Actions—Memphis	163
Heligoland	163
Lissa	164
Point Tetras	173
German Fleets, Armored, Table of	73
Description of	75
Fast cruisers, Table of	80
General-service, Table of	81
Ordnance, Table of measurements	241
Description of	244
Types and calibres of	317
Ratios of elements of iron-clad vessels	390
Personnel—Departmental organization	418
Inscription	419
Cadre	419
Grades	419
Fleet divisions	421
Budgets	434
Grades—Officers of navy of Argentine Confederation	399
Austria	400
Brazil	406
England	410
France	416
Germany	419

	PAGE
Grades—Officers of navy of Holland.....	421
Italy.....	421
Spain.....	427
United States.....	431
Grand Gulf, Bombardment of earthworks of.....	144
Greek Fleet, Table of.....	82
Description of.....	83
Ordnance, Description of.....	272
Types and calibres of.....	317
Departmental organization.....	433
Budgets.....	434
Grooves—French.....	187
French modified.....	187
Woolwich.....	187
English plain.....	187
Armstrong, for breech-loader.....	192
shunt.....	192
French, model 1870.....	228
Krupp.....	245
Parrott.....	288
Dahlgren.....	288
Whitworth.....	219
Guns—Muzzle-loaders: Woolwich.....	186
English converted.....	189
Armstrong.....	192-194
French.....	229
United States smooth-bore.....	283
converted.....	285
Parrott.....	285
Breech-loaders: Armstrong, original.....	193
improved.....	195
French, model 1870.....	225
model 186.....	228
Krupp, government pattern.....	244
new long.....	435
Finspong.....	276
United States.....	287
Penetration of English, in armor targets.....	319
German, " ".....	320
French, " ".....	321
Krupp's new long.....	435
Gun-carriages—Field: English.....	196
French.....	236
German.....	264
United States.....	289
Boat: English.....	197
French.....	235
German.....	263
United States.....	289
Turret: English.....	203
French.....	232
German.....	263
Razkazoff depression.....	279
Ericsson's.....	298
Broadside: French slide.....	230
directing-bar.....	234
Vavasseur.....	220
German Brookwell.....	249
slide.....	254

	PAGE
Gun-carriages—Broadside: German half-slide	259
United States Marsilly	292
directing-bar	293
slide	296
Ericsson's slide	296
United States friction-drum	299
Mitrailleuse: French	236
Hotchkiss	306
Gatling	308
French centre pivot	233
German " "	260
United States pivot	295
Gun-locks—United States cannon	305
Gatling	309
Gunpowder—English	206
French	236
German	265
United States	299
Harvey towing torpedo	331
Hatteras Inlet, Bombardment of	139
Heligoland, Action off	163
Hercules, Construction of iron hull of	383
Herreshoff torpedo-boat	341
Hilton Head, Bombardment of	140
Holland Fleet, Armored, Table of	84
Description of	86
Unarmored, Table of	88
Ordnance, Description of	272
Types and calibres of	317
Personnel — Departmental organization	421
Grades	421
Cadre	422
Cruising stations	422
Budgets	434
Hotchkiss machine-gun	305
projectiles	306
magazine rifle	315
Hydraulic Compressors—English	203-206
German	257-263
United States	296
Loading apparatus, English	205
Gun-lift, English	205
Inscription, Maritime—Austrian	401
French	415
German	419
Italian	423
Japanese	425
Spanish	429
Invincible, Construction of iron hull of	388
Iron-clads <i>versus</i> wooden vessels—Hampton Roads	167
Roanoke River	167
Albemarle Sound	168
Black Sea	168
Ylo	169
Iquique Harbor	169
Italian Fleet, Armored, Table of	90
Description of	91
Fast cruisers, Table of	94
General-service, Table of	95

	PAGE
Italian Ordnance, Table of measurements of.....	269
Description of.....	272
Types and calibres of.....	317
Personnel—Departmental organization.....	422
Grades.....	422
Inscription.....	423
Cadre.....	424
Budgets.....	434
Japanese Fleets, Armored, Table of.....	96
Description of.....	97
Unarmored, Table of.....	97
Ordnance, Description of.....	272
Types and calibres of.....	318
Personnel—Departmental organization.....	424
Dock-yards.....	424
Cadre.....	425
Inscription and enlistment.....	425
Budgets.....	434
Kagosima, Bombardment of.....	146
Kearsarge and Alabama, duel.....	171
Krupp Guns—Standard German, Measurements of.....	242
New long guns of 30 to 35 calibres.....	435
Description of standard German.....	244
Groove.....	245
Lay's torpedo.....	329
Lewis's torpedo.....	343
Lissa, Battle of.....	164
Loading-gear, English hydraulic.....	205
Loading-plate—French.....	239
German.....	249
United States.....	287
Machine-guns—Gatling.....	308
Hotchkiss.....	305
Nordenfeldt.....	276
Palmerantz.....	276
Marine Infantry and Artillery—Argentine.....	399
Brazilian.....	407
Chilian.....	407
Dutch.....	422
English.....	411
French.....	417
German.....	420
Italian.....	424
Spanish.....	423
Turkish.....	429
United States.....	432
Memphis, Action off.....	163
Menzing towing-torpedo.....	333
Meteor and Bouvet, duel.....	172
Mitrailleuse, French.....	230
Monitor and Merrimac, duel.....	170
Muzzle-loading Guns—Woolwich.....	186
Armstrong.....	192
Whitworth.....	218
Vasseur.....	219
French.....	229
United States smooth-bore.....	283
rifles.....	285
Nipping-gear, Scott's.....	202

	PAGE
Nipping-gear—French.....	233
German.....	255
Vavasseur.....	220
Nordenfeldt machine-gun.....	276
Norwegian Fleet, Armored, Table of.....	99
Description of.....	100
Unarmored, Table of.....	101
Ordnance, Table of measurements of.....	273
Description of.....	276
Types and calibres of.....	318
Personnel—Departmental organization.....	425
Enlistment.....	425
Cadre.....	426
Budgets.....	434
Ordnance—Argentine.....	180
Austrian.....	177, 317
Brazilian.....	180, 317
Chilian.....	181, 317
Chinese.....	181, 317
Danish.....	181, 317
Dutch.....	272, 317
English.....	182, 317
French.....	221, 317
German.....	241, 317
Greek.....	272, 317
Italian.....	269, 317
Japanese.....	272, 318
Norwegian.....	273, 318
Peruvian.....	279, 318
Portuguese.....	279, 318
Russian.....	277, 318
Spanish.....	280, 318
Swedish.....	273, 318
Turkish.....	280, 318
United States.....	281, 318
Palliser gun-construction.....	217
projectiles.....	208
Palmeranz machine-gun.....	276
Passage of Forts—Jackson and St. Philip.....	154
Vicksburg (up stream).....	156
(down stream).....	159
Port Hudson Earthworks.....	156
Morgan.....	157
Passes of the Mississippi, dash.....	165
Penetration of Armor—English guns.....	319
French.....	321
German.....	320
Krupp's new 30 and 35 calibre guns.....	435
Personnel—Argentine Confederation.....	399
Austrian.....	400
Brazilian.....	405
Chilian.....	407
Chinese.....	408
Danish.....	433
Dutch.....	421
English.....	408
French.....	412
German.....	418
Greek.....	433

	PAGE
Personnel—Italian	422
Japanese	424
Norwegian	425
Peruvian	433
Portuguese	433
Russian	426
Spanish	427
Swedish	425
Turkish	429
United States	430
Peruvian Fleet, Description of	103
Ordnance, Description of	279
Types and calibres of	318
Personnel, Departmental organization of	433
Point Tetras, Action off	173
Portuguese Fleet—Armored corvette	104
Unarmored fleet, Table of	105
Ordnance, Description of	279
Types and calibres of	318
Personnel—Departmental organization	433
Cadre	433
Cruising stations	433
Budgets	434
Primers—English friction	212
electric	213
French percussion	239
friction	239
German friction	267
United States percussion	304
friction	304
Projectiles—Distinguishing marks of English	216
Woolwich	208
Palliser	209
Armstrong segment	209
German “	265
Whitworth	219
French	237
German	265
United States	299
Hotchkiss	306
Ratios of elements of iron-clad vessels, Table of	300
Razkazoff depression gun-carriage	279
Roanoke Island, Bombardment of	141
Russian Fleet, Armored, Table of	106
Description of	108
General-service, Table of	112
Ordnance, Table of measurements of	277
Description of	279
Types and calibres of	318
Personnel—Departmental organization	426
Inscription	426
Fleet divisions	426
Budgets	434
Scott's gun-carriage	200
nipping-gear	202
Sights—English	213
French	239
German	267
United States	305

	PAGE
Simonoseki, Bombardment of	145
Singer's torpedo for harbor defence	346
Slides—English upper-deck gun	198
ordinary broadside	199
heavy broadside	200
turret	205
French ordinary broadside	232
heavy broadside	231
barbette turret	232, 360
centre pivot	234
German broadside	251
heavy pivot	257
half "	259
centre "	260
United States ordinary pivot	295
heavy broadside	296
turret	298
Slide-rollers—French	232
German	255
Small-arms—Snider	311
Tabatière	311
Krnka	312
Springfield	312
Peabody-Martini	313
Werndl	313
Mauser	314
Le Gras	314
Berdan	315
Hotchkiss magazine	315
Remington	315
Spanish Fleet, Armored, Table of	116
Description of	117
Unarmored, Table of	118
Description of	120
Ordnance, Description of	280
Types and calibres of	318
Personnel—Departmental organization	427
Grades	427
Cadre	428
Inscription	429
Cruising stations	429
Budgets	434
Sumter, Bombardment of	151
Assault of	160
Swedish Fleet, Armored, Table of	99
Description of	100
Unarmored, Table of	101
Ordnance, Table of measurements of	273
Description of	276
Types and calibres of	318
Personnel—Departmental organization	425
Enlistment	425
Cadre	426
Budgets	434
Thornycroft torpedo-boat	339
Torpedoes—Whitehead	325
Lay	329
Harvey towing	331
Menzing "	333

	PAGE
Torpedoes—French towing.....	333
American spar.....	334
Wood and Lay's spar.....	335
Lewis's drifting.....	343
Frame.....	345
Brooks's channel.....	345
Singer's ".....	346
Barrel ".....	346
Clearing channels of.....	350
Torpedo Boats—Thornycroft.....	339
Yarrow.....	340
Herreshoff.....	341
Submarine.....	343
Launches.....	342
Vessels—Pietro Micca.....	94, 336
Rau.....	102-337
Vesuvius.....	47, 337
Ziefhen.....	337
Uzreef.....	337
Alarm.....	130, 337
Intrepid.....	129, 338
Destroyer.....	338
Uhlan.....	339
Fuses—Time.....	347
McEvoy's time.....	347
Hill's.....	348
McEvoy's percussion.....	348
Friction.....	348
Sulphuric-acid.....	349
Harvey's.....	349
Electric.....	349
Actions—Shah and Huascar.....	351
Russian boats off Batoum.....	351
Constantine and Turkish vessel.....	352
Cushing's attack on Albemarle.....	352
Russian attack on Duba Saife.....	352
at Sulina.....	352
Rustschuk.....	353
Soukum Kaleh.....	353
Confederate attack on Minnesota.....	353
Housatonic.....	353
Training-gear—German windlass.....	253
for cabin carriage.....	254
heavy slides.....	256
English windlass.....	200
rack and pinion.....	200
French rack and pinion.....	231
barbette slide.....	232
centre pivot.....	234
United States rack and pinion.....	296
Turkish Fleet, Armored, Table of.....	121
Description of.....	123
Unarmored, Table of.....	125
Ordnance, Description of.....	280
Types and calibres of.....	318
Personnel—Departmental organization.....	429
Inscription.....	429
Cadre.....	429
Budget.....	434

	PAGE
Turret—United States monitor.....	357
English revolving.....	358
French ".....	359
barbette.....	360
Carriages: French.....	232
English.....	203
German.....	263
United States.....	298
Uchatius gun-construction.....	180
United States Fleet, Armored, Table of.....	128
Description of.....	129
Unarmored, Table of.....	131
Description of.....	134
Ordnance, Table of measurements of.....	281
Description of.....	283
Types and calibres of.....	318
Conditions affecting architectural development.....	362
Ratios of elements of monitor Onondaga.....	391
Monitor turret.....	357
Personnel—Departmental organization.....	430
Dock-yards.....	430
Grades and assimilated rank.....	431
Cadre.....	432
Enlistment.....	432
Cruising station.....	432
Budgets.....	434
Spar-torpedo.....	334
Vavasseur construction.....	219
compressor.....	220
nipping-gear.....	220
Vents—French.....	227
Armstrong B. L.....	193
German.....	248
United States.....	287
Vent-guards, French.....	240
Vicksburg, Dash of the Arkansas past Farragut's fleet.....	166
Wads—English papier maché.....	210
French sea-weed.....	238
Warrior, Construction of iron hull of.....	381
Weehawken and Atlanta, duel.....	171
Whitehead torpedo.....	325
Whitworth gun-construction.....	218
groove.....	219
projectiles.....	219
breech mechanism.....	218
Windlass for in and out gear—English.....	200
German.....	253
Wood scale, English.....	213, 216
Woolwich—Description of guns.....	186
Measurements of guns.....	182
Groove.....	187
Projectiles.....	208
Yarrow torpedo-boat.....	340

113



RETURN
TO →

CIRCULATION DEPARTMENT
202 Main Library

LOAN PERIOD 1

2

3

RETURN
TO →

CIRCULATION DEPARTMENT
202 Main Library

642-3403

LOAN PERIOD 1

2

3

4

5

6

Desk
ste

LIBRARY USE

This book is due before closing time on the last date stamped below

DUE AS STAMPED BELOW

LIBRARY USE FEB 3 1979

REC. CIR. FEB 3 1979

BERKELEY

UNIVERSITY OF CALIFORNIA, BERKELEY

FORM NO. DD6A, 7m, 3/78

BERKELEY, CA 94720

©s

YC 62105

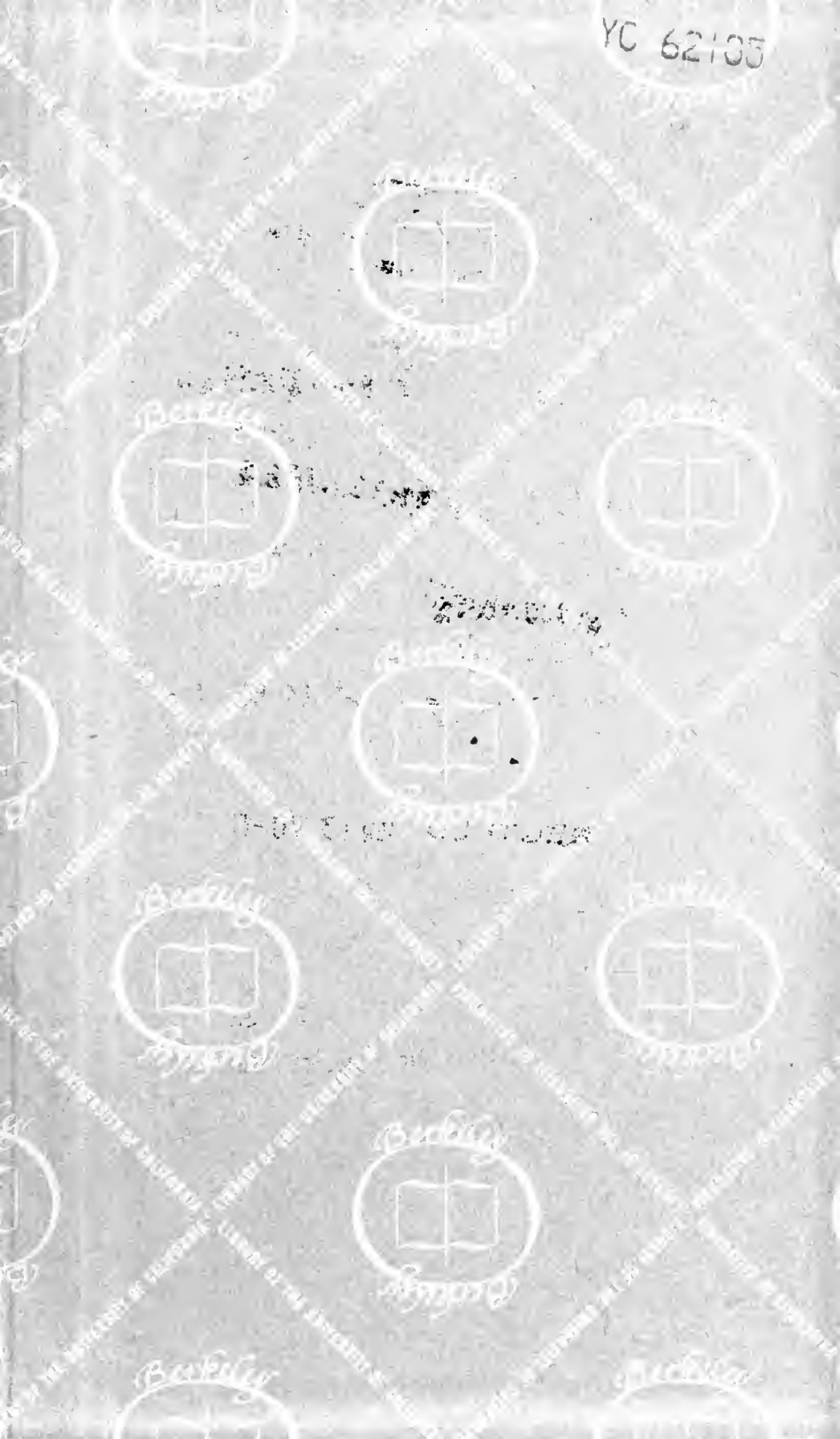

THE UNIVERSITY OF CHICAGO

