

EX LIBRIS

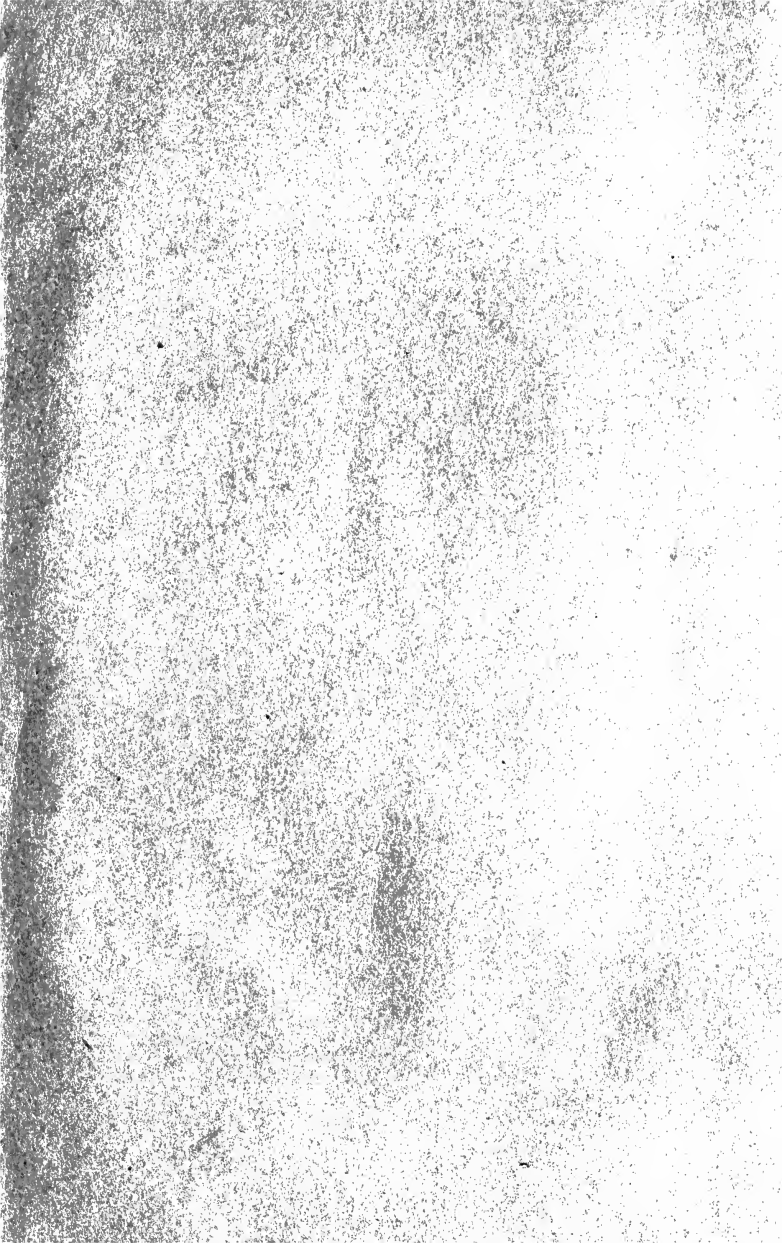

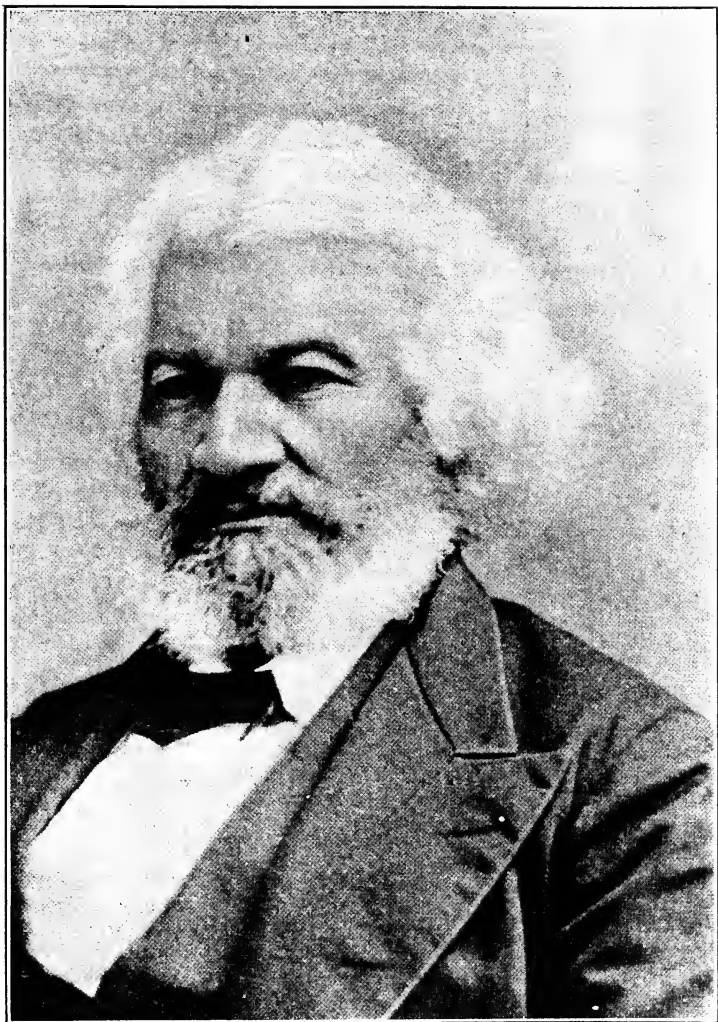

FREDERICK DOUGLASS

man

THE NEGRO IN OUR HISTORY.

BY

CARTER G. WOODSON, Ph.D.

*Editor of The Journal of Negro History, author of The Education
of the Negro Prior to 1861, A Century of Negro Migration,
and of The History of the Negro Church*



THE ASSOCIATED PUBLISHERS, INC.
WASHINGTON, D. C.

ABSTRACT

E185
W8

Copyright, 1922
By THE ASSOCIATED PUBLISHERS

To
MY BROTHER
ROBERT HENRY WOODSON

PREFACE

THIS book was written five years ago and would have been published at that time, had not the high cost of printing during the World War rendered its manufacture too expensive. A few pages have been added to bring the work nearer to the present date, but the leading facts as set forth herein appear as they were originally written.

The purpose in writing this book was to present to the average reader in succinct form the history of the United States as it has been influenced by the presence of the Negro in this country. The aim here is to supply also the need of schools long since desiring such a work in handy form with adequate references for those stimulated to more advanced study.

In this condensed form certain situations and questions could not be adequately discussed, and in endeavoring thus to tell the story the author may have left unsaid what others consider more important. Practically all phases of Negro life and history have been treated in their various ramifications, however, to demonstrate how the Negro has been influenced by contact with the Caucasian and to emphasize what the former has contributed to civilization.

The author is indebted to Mr. David A. Lane, Jr., who kindly assisted him in reading the entire proof.

CARTER G. WOODSON.

Washington, D. C.

April, 1922.

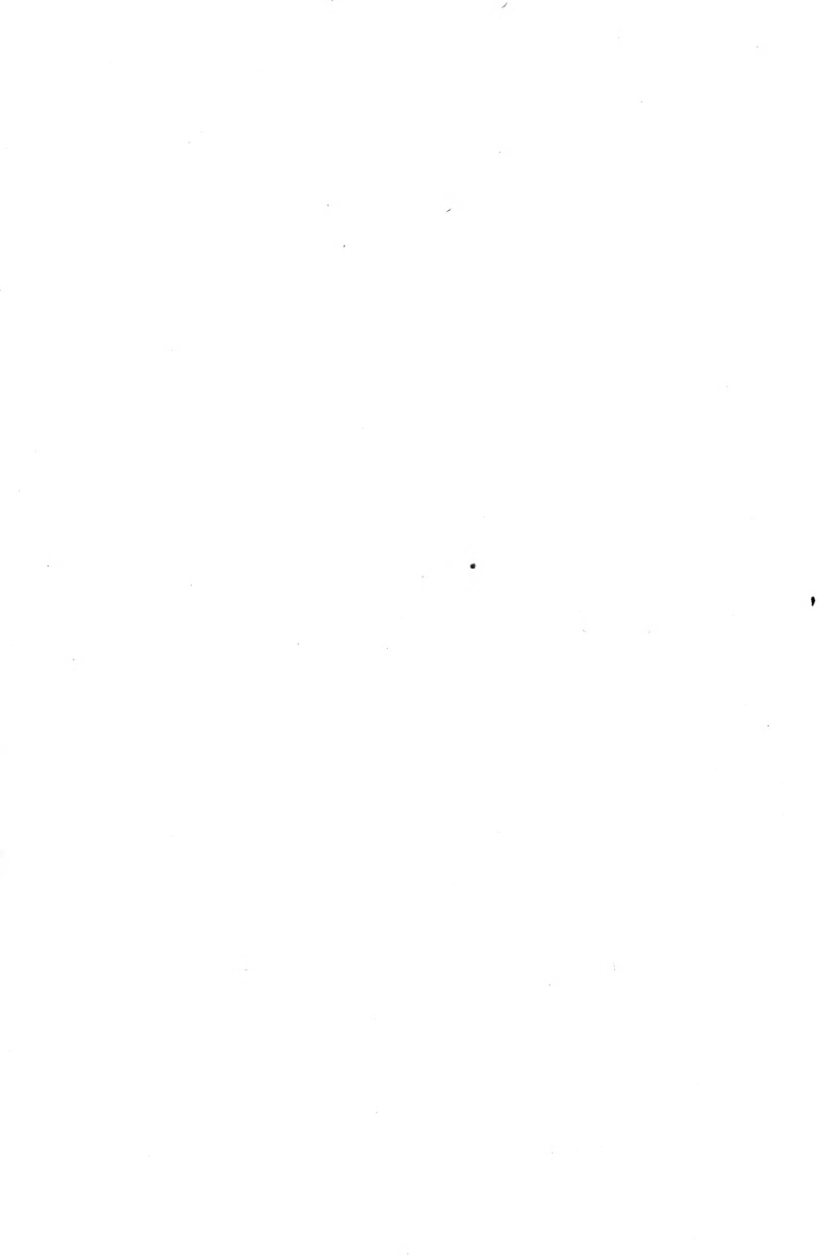

CONTENTS

CHAPTER	PAGE
I. THE NEGRO IN AFRICA	1
II. THE NEGRO ENSLAVED	15
III. SLAVERY IN ITS MILD FORM	34
✓ IV. THE NEGRO AND THE RIGHTS OF MAN	51
V. REACTION	71
VI. A DECLINING ANTISLAVERY MOVEMENT	86
✓ VII. ECONOMIC SLAVERY	99
✓ VIII. THE FREE NEGRO	124
IX. BLAZING THE WAY	138
X. COLONIZATION	153
XI. ABOLITION	169
XII. FURTHER PROTEST	182
XIII. SLAVERY AND THE CONSTITUTION	195
XIV. THE IRREPRESSIBLE CONFLICT	208
XV. THE NEGRO IN THE CIVIL WAR	221
XVI. THE RECONSTRUCTION	239
XVII. FINDING A WAY OF ESCAPE	260
XVIII. ACHIEVEMENTS IN FREEDOM	280
XIX. THE NEGRO IN THE WORLD WAR	305
XX. THE NEGRO AND SOCIAL JUSTICE	329
APPENDIX	243
INDEX	373



LIST OF ILLUSTRATIONS

FREDERICK DOUGLASS	<i>Frontispiece</i>
	PAGE
AN AFRICAN YOUTH	2
WAGING WAR TO SUPPLY THE AFRICAN SLAVE TRADE	3
SLAVERY AMONG THE ANCIENTS	7
AN AFRICAN KING AND COUNCIL	9
GUSTAVUS VASA	13
AN AFRICAN SLAVE MARKET	17
INSPECTING A NEGRO CAPTIVE	20
BRANDING A NEGRO WOMAN SLAVE	23
THE FAITHFUL SLAVE	26
THE DASH FOR LIBERTY	35
AN ADVERTISEMENT OF A RUNAWAY SLAVE	37
GRANVILLE SHARP	38
Attorney for the Slave in the Somerset Case.	
THE PUNISHMENT OF A RUNAWAY SLAVE	45
ENTERTAINMENT	48
THE DEATH OF CRISPUS ATTUCKS IN THE BOSTON MASSACRE	59
PETER SALEM AT BUNKER HILL	61
LEMUEL HAYNES	63
A Negro Soldier in the American Revolution and later a distinguished Congregational preacher to white people in New England.	
FACSIMILE OF AN HONORABLE DISCHARGE OF A NEGRO SOLDIER FROM WASHINGTON'S ARMY	64
PHYLLIS WHEATLEY	68
BENJAMIN BANNEKER'S ALMANAC	69
TOUSSAINT L'OUVERTURE	72
The Liberator of Haiti.	
BENJAMIN FRANKLIN	74
An Advocate of Freedom.	

	PAGE
RICHARD ALLEN	78
The Founder of the African Methodist Episcopal Church.	
AN EARLY COTTON GIN	79
ANOTHER SORT OF SLAVERY	83
THOMAS JEFFERSON	90
An Antislavery Reformer.	
THE NEGRO CALLS A HALT	92
NAT TURNER	94
THE MOTHER AND CHILD	96
JOSIAH HENSON	101
Prototype of <i>Uncle Tom's Cabin</i> .	
A SLAVE AUCTION	103
A PLANTATION	106
RILLIEUX'S EVAPORATING PAN	110
THE PURSUIT OF A SLAVE	113
HARRIETT TUBMAN	115
NEW YORK AFRICAN FREE SCHOOL No. 2	135
Built a century ago.	
FREEDOM'S JOURNAL	137
A Negro Newspaper edited a century ago.	
EMLÉN INSTITUTE	139
A Secondary School in Mercer County, Ohio, admitting Negroes in 1842.	
ELLEN CRAFT	142
A Fugitive disguised as her Master.	
WILLIAM STILL	143
An Agent of the Underground Railroad.	
MYRTILLA MINER	144
A missionary Teacher of Negroes.	
DR. J. McCUNE SMITH	145
FREE NEGROES IN THE CRISIS	146
WILLIAM WELLS BROWN	147
ALEXANDER CRUMMELL	148
HENRY HIGHLAND GARNETT	149
J. W. C. PENNINGTON	150
SAMUEL R. WARD	151
HARRIETT BEECHER STOWE	152
PAUL CUFFE	156
The first actual Colonizer.	

Illustrations

xiii

	PAGE
LOTT CARY	158
JOHN B. RUSSWURM	160
ROBERT PURVIS	162
WILLIAM WILBERFORCE	165
MARTIN R. DELANEY	167
An Author, Physician, and Leader before the Civil War.	
WILLIAM LLOYD GARRISON	170
LEWIS TAPPAN	171
WENDELL PHILLIPS	172
ANTISLAVERY APOSTLES	173
PRUDENCE CRANDALL	175
A Martyr in the uplift of the Negro.	
LUNSFORD LANE	176
A Native of North Carolina, who lectured in the North against slavery.	
LUCRETIA MOTT	177
CHARLES LENOX REMOND	178
SOJOURNER TRUTH	179
FREDERICK DOUGLASS	180
SOUTHERN ABOLITIONISTS	183
GERRIT SMITH	185
WHITE MARTYRS IN THE CAUSE OF ABOLITION	189
SENATOR JOHN P. HALE	193
JOHN QUINCY ADAMS	196
The Champion of Free Speech.	
JOHN C. CALHOUN	199
JOSHUA R. GIDDINGS	200
FRIENDS OF THE FUGITIVES	201
WILLIAM H. SEWARD	202
PROMOTERS OF THE UNDERGROUND RAILROAD	204
JOSEPH CINQUE	209
CHARLES SUMNER	210
HENRY WARD BEECHER	214
A Champion of Freedom.	
BENJAMIN F. WADE	219
The Defier of the Secessionists.	
JOHN BROWN	220
ABRAHAM LINCOLN	222

	PAGE
NEGROES IN THE SERVICE OF THE CONFEDERATES	224
U. S. GRANT	225
FACSIMILE OF THE ORIGINAL DRAFT OF THE EMANCIPATION PROCLAMATION	231
ROBERT GOULD SHAW	233
Leading the Fifty-fourth Massachusetts Regiment.	
COL. T. W. HIGGINSON	235
A Commander of Negro Troops.	
TEACHING THE FREEDMEN	241
SOME FACTORS IN THE RECONSTRUCTION	243
GENERAL O. O. HOWARD	246
JOHN M. LANGSTON	247
JOHN R. LYNCH	248
A Member of Congress.	
H. R. REVELS	249
United States Senator from Mississippi.	
SOME NEGRO CONGRESSMEN	250
B. K. BRUCE	251
United States Senator from Mississippi.	
JOSEPH H. RAINEY	252
A Member of Congress.	
JAMES T. RAPIER	253
A Member of Congress.	
P. B. S. PINCHBACK	254
Acting Governor of Louisiana.	
THE NEW FREEDOM	257
The first mixed jury in the District of Columbia.	
R. T. GREENER	264
JOSEPH C. PRICE	266
KELLY MILLER	267
BISHOP H. M. TURNER	269
A fearless Spokesman for his People.	
BOOKER T. WASHINGTON	275
W. E. B. DUBOIS	276
OSWALD GARRISON VILLARD	277
MOORFIELD STOREY, A FRIEND OF THE OPPRESSED	278
President of the National Association for the Advancement of Colored People.	

Illustrations

XV

	PAGE
A NEGRO COUNTRY SEAT	282
The Home of Scott Bond.	
THE RESIDENCE OF MADAME C. J. WALKER	283
JULIUS ROSENWALD	288
ANDREW CARNEGIE	289
JOHN D. ROCKEFELLER AND HIS SON	290
ROBERT RUSSA MOTON	291
MATZELIGER'S LASTING MACHINE	295
GRANVILLE T. WOODS	297
H. O. TANNER'S <i>Christ and Nicodemus</i>	300
PAUL LAURENCE DUNBAR	302
A RESULT OF THE MIGRATION	311
A Negro Teacher with Pupils of both Races.	
COLONEL CHARLES YOUNG	317
THE NEW YORK FIFTEENTH IN THE WORLD WAR	319
MAJOR JOEL E. SPINGARN	324
An enemy of prejudice in the Army.	
FIRST SEPARATE BATTALION OF THE DISTRICT OF COLUMBIA	326
Receiving the Croix de Guerre in France.	
JAMES WELDON JOHNSON	331
Secretary of the National Association for the Advance- ment of Colored People.	
MISS MARY WHITE OVINGTON	333
Chairman of the Board of Directors of the National Asso- ciation for the Advancement of Colored People.	
DR. FRANCIS J. GRIMKÉ	335
A Preacher of the New Democracy.	
ARCHIBALD H. GRIMKÉ	338
"A Defender of his People."	

MAPS

THE DISTRIBUTION OF THE NEGRO POPULATION IN 1860	218
PERCENTAGE NEGRO IN THE POPULATION OF THE UNITED STATES BY COUNTIES, 1910	308-309

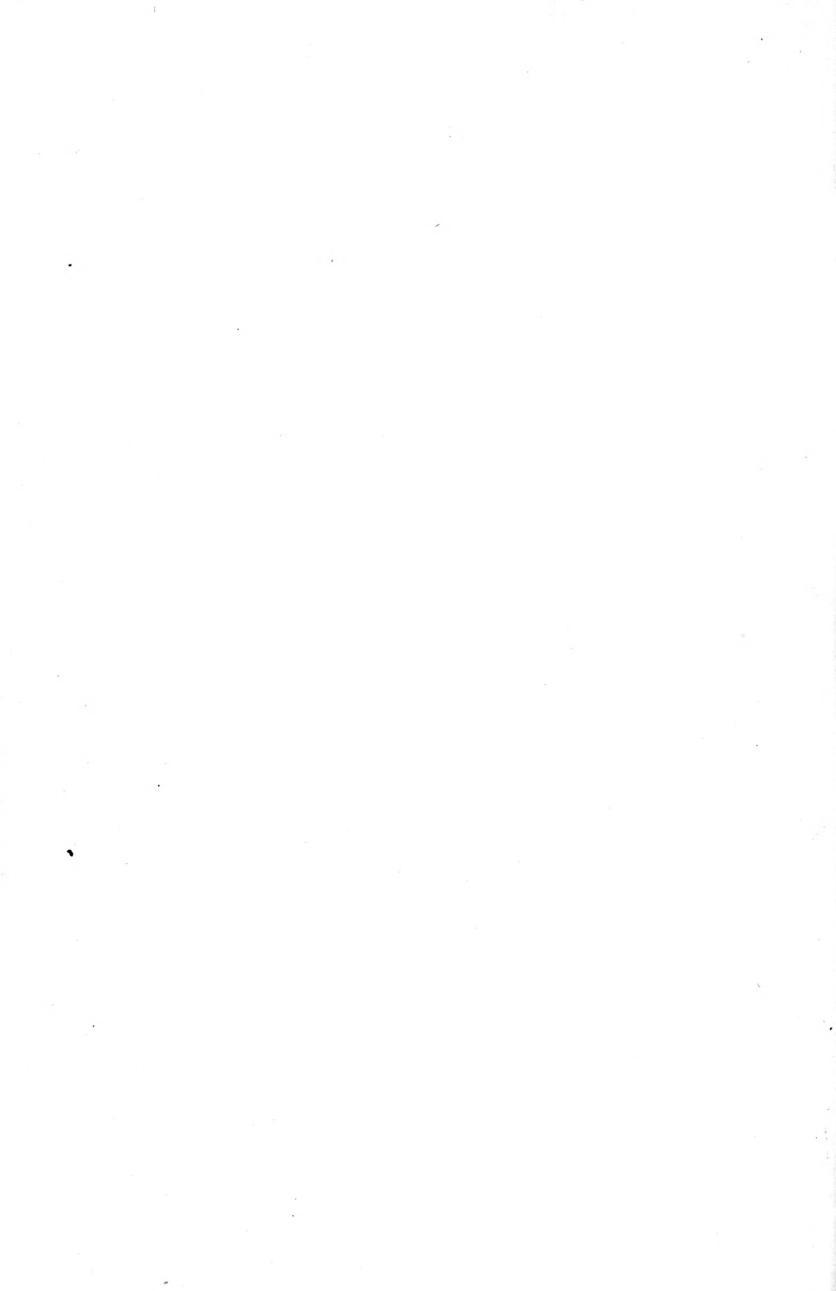

THE NEGRO IN OUR HISTORY

CHAPTER I

THE NEGRO IN AFRICA

THE ease with which the Negro thrives in centers of modern civilization, in contradistinction to the destructive effect of this influence on the belated peoples like the Indians, has evoked admiration and comment. In the beginning of the treatment of the rôle played by the Negro in our history, then, it may be well briefly to examine the situation in Africa with a view to determining exactly what accounts for the facility with which the culture of the Negroes brought to Europe and America has so easily fused with the culture generally known as that of the white man. Has the culture of the Negro anything in common with that of the western nations, or is the Negro merely imitative, as is often asserted by many writers? Since most historians in this field know practically nothing about the Negroes in Africa prior to their enslavement, it will be profitable to give their situation in that land at least a cursory examination.¹

In considering the forces effective in making the civilization of Africa it is well to note that although it is the second continent in size, it has such few inlets that it has the

¹ For more extensive treatment see W. Z. Ripley's *Races of Europe*, J. Deniker's *Races of Men*, J. Finot's *Race Prejudice*, F. Ratzel's *The History of Mankind*, Franz Boas's *The Mind of Primitive Man*, Spiller's *Inter-Racial Problems*, C. Bücher's *Industrial Revolution*, Casely Hayford's *Ethiopia Unbound* and his *Native Institutions*, James Bryce's *Impressions of South Africa*, Leo Frobenius's *The Voice of Africa*, and G. Sergi's *The Mediterranean Race*.

shortest coast-line of all. Some historians will therefore inform us that owing to this lack of good harbors Africa has not had, through commerce, sufficient contact with the outer world to keep its civilization abreast with that of other continents.

Although Africa has valuable land, it suffers from the handicap of being in the main

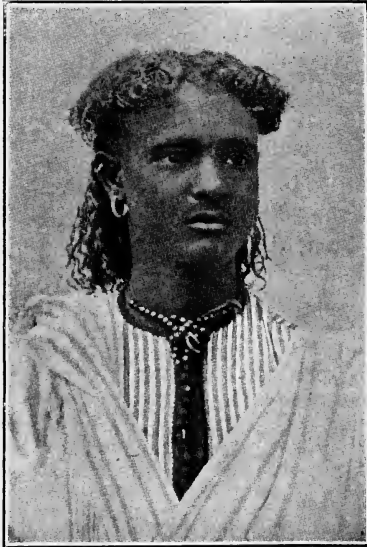

AN AFRICAN YOUTH

a high elevated table-land with rapids and falls rendering difficult the approach from the outer world; and the four great rivers, the Zambezi, the Niger, the Congo, and the Nile, are not sufficient to furnish facilities for transportation even in the interior. Africa lies in that part of the tropical world where, because of its peculiar location with reference to the directions of the winds, the climate is unusually warm and dry except in the region drained by the Congo,

where the abundant rainfall produces conditions very much like those in other parts of the torrid zone.

Because of these peculiar geographic conditions there exist various civilizations determined largely by the areas in which they have developed. For general purposes Africa may be divided into three zones. Stretching from

African a little above the equator to the south of that civilizations. circle is the region of the heaviest rainfall and consequently the most abundant vegetation. There

may be found swelling streams flowing through forests teeming with animals, natural crops, and an abundance of fruits serving as food for men, who on that account have no struggle for life. Above and below this zone are two others of less rainfall and consequently less vegetation. There it is necessary for man to cultivate the fields in order to make a living. Still farther beyond the limits of

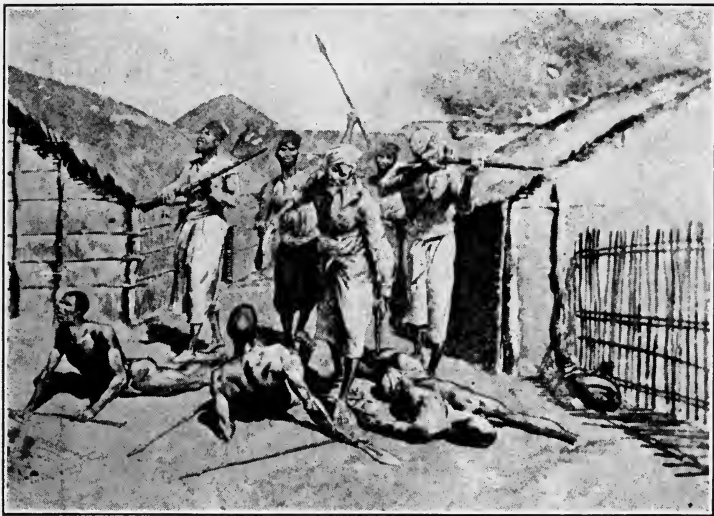

WAGING WAR TO SUPPLY THE AFRICAN SLAVE TRADE

the last named zones are areas of much less and, in the North, of practically no vegetation on account of the lack of rain. In those sections man must earn a living by pasturing cattle and the like.²

It is evident, therefore, that since environment is the great factor in the making of a people, various civilizations have sprung up in these respective zones. Those who

² This has been discussed by Jerome Dowd in *The Journal of Negro History*, Vol. II, pp. 1-16.

have lived under the equator where there is no struggle for life have not made much advancement. In that section it **Environment as a factor.** has not been possible for necessity to become the mother of invention. Those living in the areas requiring cultivation of the soil have made most progress. It has been necessary for them to bring under their control certain forces of nature to increase the food supply which nature in that zone niggardly yields. The dwellers in the arid regions are handicapped by being restricted to merely one industry from which returns are obtained with increasing difficulty. While under such circumstances the achievements of the people may in one or two respects reach a high stage, they must remain a backward stock for lack of proper environment and opportunity.

This situation throws much light on slavery and its concomitants in Africa. As there is not very much of an effort to earn a living in the region under the equator, slavery in that section seldom extends beyond that of women who are usually attached to men as wives. A man **Slavery in Africa.** in need of labor purchases additional wives to supply that need, and a wife is usually worth so many cows. As very few slaves are required and there is often a scarcity of meats, cannibalism is practiced, as the taste of human flesh does not differ materially from that of other animals. In the case of wars, therefore, when captives are taken they can be easily disposed of by sale, for the reason that they are not needed in the economy of the country.

In the zone farther north there is an urgent need for the labor of slaves. A living is obtained there with more difficulty than in the equatorial zone, and the effort on the part of one to shift arduous labor to the shoulders of another results in the enslavement of the weak to do the work of the strong. In the arid zone a slave class is not considered indispensable, since it cannot easily maintain

itself there and at the same time support superiors. As all of the population must work, free rather than slave labor is the rule.

The people of Africa inhabiting these various zones are commonly known as the black race, but because of climatic differences men in these parts have become widely different from each other. The records of archeologists indicate that the primitive African was not necessarily black, but of an Asiatic type of Ne- **African peoples.** groid features.³ There are certain records which lead to the conclusion that at one time the peoples of Africa were largely of the mulatto type, and today the natives of Africa are not generally black but exhibit in their racial characteristics all of the divergencies found among the people of color in the United States. There are in the main such types as the small primitive stock, the larger forest Negro in the center and on the west coast, and the tall blacks in the Sudan.

There seems to have been a movement of peoples and of civilizations from Asia into Egypt and from Egypt up the Nile into the interior of Africa, and again from Egypt westward to the Atlantic near the Gulf of Guinea.

There was, too, a backward movement from the West to the East causing a conflict, a fusion, and a destruction of cultures. Out of this chaos developed the Bantu, calling themselves *the people*, a war-like nation which imposed its sway and language on all of Southern Africa extending from the Gulf of Guinea.

The movements of peoples.

In the north the controlling forces centered for some

³ For a discussion of African races see *The Atlanta University Publications*, No. 20; *Select Discussions of Race Problem*. More detailed information may be obtained from G. Spiller's *Papers on Inter-Racial Problems*; *The American Journal of Anatomy*, Vol. IX, pp. 156-159; *Science N. S.*, Vol. XXXI, pp. 171-186; Thomas's *Source Book for Social Origins*, pp. 156-169; *The Journal of Race Development*, Vol. I, No. 4, pp. 482-500; and Boas's *The Mind of the Primitive Man*, pp. 251-278.

centuries in Egypt, which, although commonly regarded as a country of Asiatic civilization, was, like other parts of **Egypt and the North.** Africa, molded in this crucible of cultures. It was the land of mixed breeds or persons comparable to Negroes passing in this country as people of color. When these people were in ascendance, the great nations of the Mediterranean world, like the Greeks, the Italians, and Carthaginians, came into contact with them and were thereby influenced to the extent that investigators contend that the civilizations of southern Europe had African rather than European origin.⁴ These civilizations, however, did not endure.

It will no doubt be interesting, therefore, to trace briefly the rise and fall of some of these empires.⁵ The highest of these civilizations centered in the Nile region, with Ethiopia around the head waters of that river and Egypt **The rise of empires.** along the lower. The people of this country were mixed breeds, as evidenced by their monuments exhibiting Negro and mulatto faces. At least one-third of the Egyptians were distinctly black. History seems to indicate that the country was first settled by a Negro tribe that mingled later with the Mediterranean people coming from the North. Through this process a large number of Negroes went into Greece and even into Italy, where they influenced civilization not as slaves but as persons rising to positions of usefulness. As such, Egypt once led the world in culture. "Egypt," says Chamberlain, "acted as a channel by which the genius of Negroland was drafted off into the service of Mediterranean and Asiatic culture."

Ethiopia and Egypt were at first united, but in the course of time separated as two distinct empires. There

⁴ *The Journal of Negro History*, Vol. II, p. 331.

⁵ The rise of these empires is treated in Felix DuBois's *Timbuctoo the Mysterious*, and in F. L. S. Lugard's *Tropical Dependency*.

were various wars between the Egyptians and the Ethiopians when the former was trying to wrest the country from the invaders of the north. At no time, however, did the Negroes fail to figure conspicuously in the civilization of Egypt, as is evidenced by the fact



SLAVERY AMONG THE ANCIENTS

that full-blooded Negroes like Ra Nehesi and Nefertari sat on the Egyptian throne, and that many other of its rulers were of decidedly Negroid features. The affairs of the Ethiopian and Egyptian empires did not seem to become

separate until during the middle empire of Egypt, when Nepata and Meroe became centers of a largely native civilization. The new empire, however, continued its wars against the Ethiopians and gradually incorporated the country, until Ethiopia finally became subject to that land. In the course of time, however, Ethiopia asserted itself, easily overran Egypt, and appointed a son of the king of Ethiopia to rule the land of the Pharaohs.

The Negro was then at his best as a constituent factor in the affairs of the Egypto-Ethiopian empire. When, however, the country was conquered by the Assyrians and then by the Persians, Egypt became subject to the invaders from Asia, whereas Ethiopia continued its way. Ethiopia was again invaded by a Greek influence from the East and the influences of the tribes from the Sudan on the West, but the Ethiopian language and government tended to endure. Ethiopians persistently gave trouble to the Romans, who undertook to subdue them and failed thoroughly to do so because of their interior position. This country lay asleep during the Middle Ages. In later years it became known as Nubia, and finally as Abyssinia, after having experienced various conquests and subjugations resulting in changes which have not yet succeeded in blotting out altogether its ancient civilization.

With the exception of what the historian Herodotus has left in fragmentary form, not much is known about the early nations established on the Niger or the Sudan. They are connected in history with Ethiopia and
Sudan and the Niger. Egypt as a center of culture distinctly African, as evidenced by the figures of Sherbro and the megaliths of Gambia. The first actual history dates from the approach of the Mohammedans about the year 1000. The Mohammedans came largely as traders and gave much stimulus to the rise of commerce among these people, not

utterly changing the civilization but decidedly influencing the life and history of the people. Drawing no color line, these Arabs blended readily with the Negroes and gave rise to the prominence of certain Arabised blacks represented by Antar, who in Arabia became the national hero and one of the great poets of Islam. Carrying their civilization later into Spain, the Africans attained distinction there also, for a Negro poet resided at Seville and in 1757 a Negro founded a town in lower Morocco.



AN AFRICAN KING AND COUNCIL

In the eleventh century the Moslems found in the west the far advanced kingdom of Ghana, which they conquered after much resistance of the natives, who had an army of two hundred thousand men and sufficient wealth **The Kingdom of Ghana.** When this kingdom declined **of Ghana.** in the thirteenth century, Melle superseded it and added greatly to its wealth by the expansion of its commerce through welcoming the Mohammedan traders. They found

evidence of advanced civilizations even in the Congo, and learned that the Zulu chiefs, whose armies swept south-eastern Africa, exhibited unusual power of military organization.

Among the cities where this exceptional culture was discovered was that of Jenne, from which the modern name Guinea has been obtained. This city experienced, as usual, **The State of Jenne.** migrations and movements frequent in other parts of Africa, destroying many of the evidences of civilization. But according to Frobenius, the traveler observed an advanced culture in their terra-cotta industry, in their achievements in clay and stone and iron, in their glass beads, earthen and glassware, and in the dexterity of their weaving. This civilization shows the city group like that around Timbuctu and Hausa. These cities had a government largely like that of an autonomy of **Timbuctu.** modern times—what we would call the social and industrial state, but of an essentially democratic order. These achievements so impressed the world that in keeping with other claims based on prejudice, white men have undertaken to accredit whites with this culture.

There developed also the states commonly known as the Ashanti and Dahomey,⁶ which, because of their orgies of war and sacrifice of human beings exhibited a striking contrast to the city democracy of “elevated religious ideas, **Ashanti and Dahomey.** organized industry, and noble art.” So far as known, however, the white race has not yet made a strenuous effort to prove that this civilization was Caucasian, doubtless for the reason that these very backward conditions rendered the country so weak that it finally developed into a region of internecine wars which

⁶ The cruelty practiced in Dahomey is evident from a speech of the king of that country, found in *The Journal of Negro History*, Vol. I, p. 65.

paved the way for the lucrative slave trade carried on by the Christian nations.

In the regions of the great lakes flourished other centers of civilization. There, evidences of culture and the mining of silver and gold and trade in precious stones appeared. These Africans were the first to smelt iron and to use it as the great leverage of civilization by which the world has been enabled to accomplish its wonders in modern times. They had useful iron implements, erected well-constructed buildings and fortifications, made beautiful pottery, and worked extensively in the precious metals. As indicated by their utensils and implements, they had made much more advancement in religion than some of the other tribes, inasmuch as they had temples of significance comparing favorably with those of the Greeks and Romans. The government established was based on slavery and the people devoted themselves to agriculture and other industries.

There emerged, too, the large kingdom of Songhay, covering the period from the year 700 to 1335, with three well-connected dynasties distinguished by great warriors who extended the territory of the empire, and **The Kingdom** statesmen who distinguished themselves in **of Songhay.** administering its affairs. After resisting the Mohammedans for some time, the sixteenth king was converted to their faith about the year 1000. Among the greatest of these rulers was Soni Ali, noted for his military exploits and his success as a statesman. The country again saw something like a return to a golden age under another distinguished ruler called Mohammed Askia, who brought the country into contact with Egypt and the outer world, and finally marched against neighboring empires, which he conquered and ruled with a provincial system very much like that of Rome. He established schools of learning and promoted the study of law, literature, the natural sciences, and medicine.

In the end, however, this empire fell into the hands of undesirable rulers, and according to the pious annalist, "All was changed in a moment. Danger took the place of serenity, destitution of abundance; trouble, calamities, and violence succeeded to tranquillity. Everywhere the populations began to destroy each other. In all places and in every direction rapine became the law, war spared neither life, nor property, nor the position of the people. Disorder was general, and it spread everywhere till it reached at last the highest degree of intensity." "Things continued thus," adds the historian, "until towards the moment in which the Songhay dynasty approached its end, and its empire ceased to exist. At this moment faith was exchanged for infidelity; there was nothing forbidden by God which was not openly done. Men drank wine, they gave themselves up to vice. . . . Because of these abominations, the Almighty in his vengeance drew down upon the Songhay the victorious army of the Moors, whom he brought through terrible sufferings from a distant country. Then the roots of this people were separated from the trunk, and the chastisement they underwent was exemplary."⁷

It is clear that African culture prior to the exploitation of the new world was in many respects like the culture of Europe. The natives far removed from the equator had reached the stage of easily earning a subsistence by using iron implements, a thing which European nations were late in learning. In art and architecture they had advanced far beyond the primitive stage, in literature their achievements attained the rank of the world's best classics in the *Tarik é Soudan*, and in religion and morals most of them kept abreast with the times. In government the Africans united the best in democracy and monarchy. Theirs was a slave society, but

⁷ F. L. S. Lugard, *A Tropical Dependency*, pp. 283-284; *The Journal of Negro History*, Vol. II, p. 140.

there was a healthy sentiment against the exploitation of men. With the thinking class birth did not differ from birth; "as the freeman was born so was the slave." "In the beginning," said a pious African, "our Lord created all; with Him there is neither slave nor freeman, but every one is free." "To love a king," the African thought, "is not bad, but a king who loves you is better." And it sounds a little socialistic to hear the proverbs, "If thou art poor do not make the rich man thy friend," "If thou goest to a foreign country, do not alight at a rich man's house," or "It is better to be poor and live long than rich and die young."



GUSTAVUS VASA, a talented African

The African mind exhibited during these years evidences of a philosophy not to be despised. The native philosopher found three friends in "courage, sense and insight." The African realized that "the lack of knowledge is darker than night," that "an ignorant man is a slave," and that "whoever works without knowledge works uselessly." "Not to know," he believed, "is bad; not to wish to know is worse." Adhering to a high standard of morals, the African taught the youth that "there is no medicine for hate" and that "he who bears malice is a heathen; he who injures another brings injury to himself." To emphasize opportunity the moralist reminded his fellows that "the dawn does not come twice to wake a man." To teach politeness he asserted that "bowing to a dwarf will not prevent your standing erect again." In emphasizing the truth, he asserted that "lies, however numerous, will be caught by truth when it rises," and "the voice of truth is easily known." The selfish man was

**African
proverbs.**

warned that "if you love yourself, others will hate you; if you humble yourself, others will love you." Among the Africans there was a feeling that "a man with wisdom is better off than a stupid man with any amount of charm and superstition." Such sentient expressions as "A butterfly that brushes against thorns will tear his wings," and "He who cannot move an ant and yet tries to move an elephant shall find his folly," have the ring of the plantation philosophy developed in the United States. The proverbs "When the fox dies, fowls do not mourn," and "He who goes with a wolf will learn to howl,"⁸ exhibit more than ordinary mental development.

⁸ A larger number of these proverbs appear in *The Journal of Negro History*, Vol. I, pp. 42-48; but a detailed study in this field would require R. F. Burton's *Wit and Wisdom from West Africa*, S. W. Koells's *African Native Literature*, A. B. Ellis's *The Yoruba Speaking Peoples of the Slave Coast of West Africa*, and H. Chatelian's *Folk Lore of Angola*.

CHAPTER II

THE NEGRO ENSLAVED

THAT the Negro should be enslaved was in the halcyon days of the institution no exception to the rule. Slavery was once the normal condition of the majority of the inhabitants of the world. In many countries slaves outnumbered freemen three to one. **Ancient slavery.** Greece and Rome, the most civilized of the ancient nations in which the so-called democracy of that day had its best opportunity, were not exceptions to this rule. Primitive slavery, however, differed very much from the slavery of which our forefathers remind us. Among the ancients, slavery resulted from the effort to make a safe disposition of captives in war by using them as laborers at home while citizens and subjects in good physical condition went abroad to defend the honor of the nation.

It happened that centuries ago, when African civilization was not unlike that of the emerging modern Europe, Africa was disturbed from without and within by migrations like the movement which overthrew the Roman **The Fifteenth Century.** Being too weak to resist invaders while dealing with enemies at home, Africa yielded to the attacks of restless nations. When the Bantu hordes had destroyed the peace of the African empires, there came the Mohammedans in quest of slaves to supply their harems and armies, and finally the slave traders from the United States, giving cause for local

wars to secure a labor supply for the exploitation of the New World.¹

During the seventh and eighth centuries, the Mohammedan religion well established itself in Western Asia and began to take over Northern Africa. At first Africans **Mohammedan** already enslaved were bought from their **slavery.** masters and used in war, as was the custom throughout Europe and Asia. When, however, the exigencies of those circumstances demanded a larger number of slaves than could thereby be supplied, they were seized by well planned methods involving the enslavement and depopulation of large districts of Africa. This led to the overthrow of African nations long since established as centers of culture and the rise of other States committed to the policy of profiting by the lucrative slave trade. This trade finally extended to the very interior of the continent and became the most cruel traffic in human flesh theretofore known to the world. It is only of late that it can be said that this Mohammedan slave trade has been decidedly checked or brought to an end. It remained as a disgrace to certain Eastern nations during the latter part of the nineteenth century and even into the twentieth. Slavery among the Mohammedans, however, was not altogether a hopeless condition. If the slave professed faith in the tenets of Mohammed, he became a communicant in that connection, enjoying equality with the richest and the best, accepted on the principle of the brotherhood of man.

Following upon the Mohammedan quest of slaves came the discovery of America, which, being in itself a conspicu-

¹The conditions in Africa facilitating the increase in the slave trade are treated in T. K. Ingram's *History of Slavery and Serfdom*, John R. Spears's *The American Slave Trade*, W. E. B. DuBois's *Suppression of the African Slave Trade*, B. Mayer's *Captain Canot or Twenty Years of an African Slaver*, R. Drake's *The Revelations of a Slave Smuggler*, Bryan Edward's *West Indies*, and T. Clarkson's *History of the Abolition of the Slave Trade*, 2 Volumes.

ous event in the Renaissance, meant nothing less than the opening of a new field of exploitation in a hitherto unknown world. In carrying out the policy of commercial expansion so eagerly championed some years later by the leading nations of Europe, the planter class did not proceed far before they fell back on compulsory labor. At first they impressed the Indians into their service, but because of their intractability these proved in most cases to be unprofitable bondmen.

The slave trade.



AN AFRICAN SLAVE MARKET

Certain settlers established mainly in Pennsylvania, Maryland and Virginia made the experiment with indentured white servants. Some of these were, like the Pennsylvania Redemptioners, respectable persons bound to service for a number of years to pay their expense from Europe to the New World. To Virginia and Maryland, however, were transported a large number of convicts more or less desirable than the ruined and imprisoned debtors whose release was effected by Oglethorpe

Indentured servants.

that they might try life anew in Georgia. This traffic, like the slave trade, was objectionable to some colonies, and they enacted measures to restrict it; but these were vetoed by the King of England as being contrary to acts of Parliament granting authority for the continuation of the evil. As white servants, however, could not be obtained in sufficiently large numbers to supply the demand for labor, and as the indefinite term of their service was prejudicial to the interest of their masters, there followed, in the eighteenth century, an increasing demand for Negro slaves in the agricultural colonies.

The Christians, like the Mohammedans, justified their enslavement of foreigners on the ground of their being captives in war, but in the eighteenth and nineteenth centuries, when the Europeans were engaged in the exploitation of **Christian** the New World, slaves were no longer merely **slavery.** taken over as a sequel of war but became also an object of commerce to supply the colonies with cheap labor. This change of attitude was justified by the Christian world on the ground that, although it was contrary to an unwritten law to enslave a Christian, this principle was not applicable to the unconverted Negroes. Driven later from this position when numerous Negroes accepted Christianity, they salved their consciences by a peculiar philosophy of the officials of the church to the effect that conversion did not work manumission in the case of the Negro who differed so widely from the white man. The substance of this was soon incorporated into the laws of the colonies.

Prior to the operation of the slave trade for the purpose of exploitation, there had been sufficient infiltration of the Negroes into southern European countries to make their presence no exception to the rule. **African** slaves were brought to Spain, and this trade **slaves in** was further extended by the Portuguese when **Europe.** they conquered the Mohammedans of North Africa. After

the extensive explorations of Prince Henry, the Portuguese ships were bringing to that country more than seven or eight hundred slaves every year to serve as domestic servants and to work the estates evacuated by the Moors. Slaves were so common in the city of Seville in 1474 that Ferdinand and Isabella nominated a celebrated Negro, Juan de Valladolid, as the "mayoral of the Negroes" in that city.²

This slavery in the Iberian peninsula, of course, was of a mild form; for, despite the suggestions of men commercially inclined, the Christian Queen Isabella had refused to permit the traders to embark upon the enterprise as a commercial one. Furthermore, to prevent the spread of heathenism and to promote religion, she allowed only Christian Negroes to be carried to the colonies.³ At the death of Isabella, however, King Ferdinand, who was less interested in the Negroes than was his companion, gradually yielded to the requests of the merchant class, and unconverted Negroes were brought to the Spanish colonies. But Ferdinand did not give extensive privileges to all persons desiring to import Negroes, and at times undertook to check the trade. In the reign of Charles V, Bishop las Casas urged a plan for importing Negroes to take the place of the enfeebled Indian slaves, and this plan, once adopted, became the policy of the Spaniards in dealing with the Negroes in their colonies.

All of the seafaring nations of Europe took part in this enterprise. The Portuguese, the first to make extensive explorations on the coasts of Africa under the direction of Prince Henry of that country, built the first slave fort at Elmina, on the Gold Coast, in 1482. The Dutch, too, at the time of their struggle for freedom from Spanish domination in 1599,

**Slavery in
Spain.**

**Traders on
the African
Coast.**

² W. E. B. DuBois, *The Negro*, p. 146.

³ C. G. Woodson, *The Education of the Negro Prior to 1861*, p. 19.

attacked the forts of the Portuguese, then subject to Spain, and engaged in the slave trade themselves. The English, desirous of reaping some of these benefits for their own commerce, undertook in 1562 to secure this trade through Sir John Hawkins. Uniting religion with the slave trade, he ordered his crews to "serve God daily," and "to love one another."⁴ He went first to Hispaniola with three

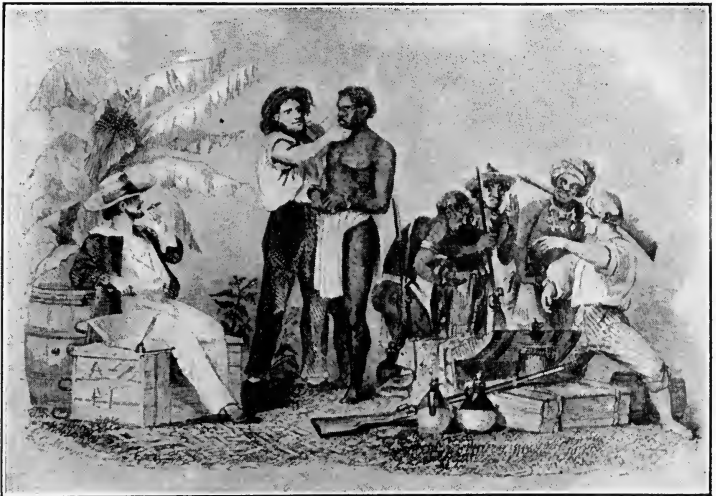

INSPECTING A NEGRO CAPTIVE

hundred Negroes whom he traded for pearls, hides and other products. The second voyage was more hazardous, and he failed in the third. In spite of his murderous plundering, however, his chronicler entreats that "his name be praised forevermore, Amen."⁵

Yet men of the type of Hawkins are not to be unsympathetically condemned. In that day there was no sharp

⁴ Hakluyt's *Voyages*, Vol. III, p. 521.

⁵ E. Channing, *History of the United States*, Vol. I, p. 115.

distinction between a pirate and an honorable seaman. Some of the sea rovers held commissions of their God-fearing sovereigns who promoted these enterprises. **Piracy and commerce.** The white race, moreover, has not yet emerged from the stage of primitive civilization when right was restricted to one's blood kin. If strangers within the gates could not be murdered, there was no moral law restraining one from abusing the subjects of non-Christian nations. Mendez believed that his slaughter of captives was for the glory of God, and Francis Drake, the notorious plunderer of his time, commended his lieutenant "to the tuition of Him that with his blood redeemed us."⁶ In this state of moral backwardness, therefore, it did not startle Christendom when there appeared in Virginia in 1619 "a Dutch manne-of-war that sold us twenty negars," thus introducing in the United States the curse of slavery from which this country has not yet been thoroughly redeemed.

The slave trade was mainly promoted through a few large trading corporations. Among the first of these were the Dutch West India Company, established in 1621, and the Royal African Company, chartered by the **Slave-trade corporations.** English in 1672. These corporations maintained a line of vessels plying between Europe and certain slave-trading ports established on the Guinea coast.⁷ The French operated in the region of the Senegal, the English on the Gambia, and the Dutch and English on the Gold Coast. In the course of time the slave trade in the interior of Africa was highly developed. Wars were being waged for the sole purpose of securing slaves for the market, and when captured they were brought to the coast and sold to the representatives of the companies with vessels in port for their exportation. They were not natives of the countries

⁶ E. Channing, *History of the U. S.*, I, p. 116.

⁷ For a sketch of the early slave trade see George F. Zook's *The Royal Adventurers Trading Into Africa*.

along the coast. In fact, Africans of these ports were seldom sold for this purpose except when a rival nation captured the slaves of the masters living in a hostile section. Most of the slaves supplying this demand were brought from the distant countries in the interior of Africa.

The commodities given in exchange for these slaves were sent out from manufacturing centers like Newport in Rhode Island and Liverpool in England. These vessels carried iron bars, rum, cloth, shells, crystal beads, brass pans, and **The Slavers.** foreign coins, to be exchanged for slaves. The slaves thus purchased had been driven to the coast in coffles, sometimes for distances of more than one thousand miles, crossing a country which had practically no facilities for transportation with the exception of those with which nature had endowed it. As it was necessary to go most of the way walking, and as the means of subsistence were not always to be secured, many of the slaves dropped dead from thirst and famine. Those who succeeded in surviving **Horrors of the** the ordeal of this drive to the coast were **Slave Trade.** presented for sale on arrival. Captives accepted as valuable were shackled and herded together like cattle in ships, which made their way to the West Indies. The space usually allowed for the standing room of a slave was just a few square inches. Crowded thus together in the lower parts of an unsanitary vessel, thousands of these unfortunates died of various diseases before reaching America. Occasionally there would arise, among the captives on board, a riot to liberate themselves by killing their owners, but the system was finally reduced to such a safe procedure that little fear therefrom was experienced.⁸

These slaves were not brought directly to the continental ports. Slave labor did not at first seem very profitable

⁸ This trade has been described by John R. Spears in his *The American Slave Trade*.

along the Atlantic, but in the West Indies, devoted to the production of cane sugar then so much in demand, African slaves were welcomed. They were carried to these islands, where they were exchanged mainly for such raw materials as molasses which, when brought by the slavers to our ports, was manufactured into rum. With this rum the ships set out to Africa again on their triangular route connecting with the commercial centers in three widely separated parts of the world.

Slaves carried to the West Indies.

In the West Indies the Negroes were successfully exploited so as to make those islands the wealthiest colonies of the world. In the course of time, however, after having been well broken in and in some cases after having taken over a considerable portion of the western civilization, many slaves were brought from the West Indies to the United States. Some of them had then learned to read and write two or three modern languages.⁹ When,



BRANDING A NEGRO WOMAN SLAVE

however, such Negroes proved to be the source of discontent and insurrections because of the mental development they had experienced, the American colonists deemed it wiser to import slaves in their crude form directly from Africa.

As to exactly how many Negroes were thus brought away from Africa, authorities widely differ. When the slave

⁹ For the mental development of these slaves see C. G. Woodson's *The Education of the Negro Prior to 1861*, pp. 82-84; and *The Journal of Negro History*, Vol. I, pp. 177-189.

trade was in full swing 50,000 or 100,000 were brought over every year. Some authorities believe that not more than 5,000,000, while others contend **The enormity of the trade.** that 10,000,000 Africans were expatriated. But to figure out the extent to which this process of depopulation affected Africa, one must bear in mind that for every slave imported into America at least four or five others had to meet death in the numerous wars waged solely for supplying the slave market, in the inhuman drive to the coast, and in the cruel shipment in unsanitary ships hardly suitable for importing hogs. Africa probably lost more than 50,000,000 natives. When we think of how the recent conscription of 4,000,000 men upset the economic and social life in our own country, we can easily estimate the effect of the loss to Africa of 50,000,000 of its inhabitants.

The source of these Negroes will be of much interest. They came in the main from Guinea and the Gold Coast. Among these were a few of the most intelligent of the **Sources of the slaves.** Africans, the Senegalese, with an infusion of Arabic blood, especially valuable for their work as mechanics and artisans. Then there were the Mandingoes, who were considered gentle in demeanor but prone to theft. The Coromantees brought from the Gold Coast were hearty and stalwart in mind and body, and for that reason frequently the source of slave insurrections which became the eternal dread of the masters. It was said, however, that the Coromantees were not revengeful when well treated. Slavers brought over some Whydahs, Nagoes and Pawpaws, as they were much desired by the planters because they were lusty, industrious, cheerful and submissive. There came also the Gaboons, who were physically weak and consequently unsuited for purposes of exploitation. The colonists imported, too, some Gambia Negroes, prized for their meekness, whereas the Eboes

from Calabar were not desired, because they were inclined to commit suicide rather than bear the yoke of slavery. The Congoes, Angolas and the Eboes gave their masters much trouble by running away.

The lot of the slave in the West Indies was most unfortunate. Owing to the absentee ownership, the inefficient management of the plantations, and the paucity of white women to serve as restraining influences on masters, the system of slavery developed there proved to be of a cruel sort. The slaves were treated more as brutes subjected to a process known as "breaking in." Some were assigned to work among well seasoned slaves, and a few were given individual tasks. When they became well "broken in," they were grouped by families in separate quarters, surrounded by small tracts of land on which they were required to raise their own food. Such things as clothing, dried fish, molasses, rum and salt, which they could not easily produce, were issued from the plantation commissary. They went to work in gangs, some tilling the sugar cane in the fields, some to work in the mills and stills, some at handicrafts, and others in domestic service.¹⁰

**The slave
in the
West Indies.**

As few implements had been introduced and the planters of that day did not easily take to labor-saving devices, most of the cultivation of the crops was done with the hoe, which required the hardest labor. Under these conditions the slaves could not develop into a robust class and, worst of all, many of them died as a result of this drudgery. While the death-rate was unusually high, the birth-rate was exceptionally small, as there was no provision for taking care of the African newborn. Speaking of Jamaica, a surgeon said that one-third of the babies died in the first month, and few of the imported

**Hardships
the cause
of death.**

¹⁰ This purely economic aspect of slavery has been unscientifically discussed by U. B. Phillips in his *American Negro Slavery*.

women bore children. A contemporary said that more than a quarter of the babies died within the first nine days of "jaw fall," and another fourth before they passed their second year. This meant that the colonies had to depend on the importation of new African slaves, thus giving stimulus to the slave trade to supply the demand for labor.



THE FAITHFUL SLAVE

Among the Spanish and French colonists the condition of the blacks was somewhat different. The home countries in these two cases insisted on the enlightenment of the slaves and were more generous than the English in offering bondmen opportunities to toil upward. While the slaves as such did not fare much better than they did on the English plantation, the tendency of the Latins to interbreed with the blacks, and their custom of recognizing and elevating their mulatto offspring, offered a way of escape to a large number of

**The enlight-
enment of
the slaves.**

Negroes among the French and Spaniards, who cohabited with Negro women rather than bring wives from their home countries. A large number of bondmen in Latin-America secured their manumission by meritorious service and thereafter had the status of freemen.¹¹

An individual of this class closely connected with our local history was Estevanecito, or little Stephen. He arose to usefulness and prominence among the Spaniards while they were extending their explorations into Mexico and into what is now the southwestern part of the United States. Estevanecito was the moving spirit of the expedition conducted there by Fray Marcos de Niza. He was usually the forerunner of the forces preparing the way for those who were to claim the country, going far enough in advance of the expedition to clear their path of hostile Indians. His work was well planned and successfully executed during the most of his tours, but he met a stubborn resistance at Cibola, where he fell mortally wounded in trying to carry the town by storm.¹²

**Estevanecito,
the Negro
explorer.**

¹¹ This interbreeding is set forth in detail by C. G. Woodson in *The Journal of Negro History*, Vol. III, p. 335.

¹² "Leaving the northernmost Spanish settlement of the western coast," says a legend, "Fray Marcos took with him Estevan, the black companion of Cabeza de Vaca, who had been in search of the El Dorado and Seven Cities of so much concern to the Spaniards. A few weeks after setting out Fray Marcos sent Estevan in command of a number of Indians fifty or sixty leagues ahead to discover the El Dorado. The arrangement was that if Estevan found anything worth while he would send back a large cross. If the information obtained did not seem valuable, he would send a small cross. Fray Marcos was much delighted four days later when there returned an Indian bearing a large cross and describing the seven large cities of imposing lime and stone structures with portals ornamented with turquoise. Too eager to await the coming of Fray Marcos, Estevan undertook to take the city, where he was overpowered by superior forces and slain. Presenting himself as the agent of the white man, he was branded a liar by the Indians, who thought it incredible for a black man to be the agent of two whites. They found Estevan greedy, immoral and cowardly, and when he sought to escape, killed him."—See Channing, *History of the United States*, Vol. I, pp. 75-76.

Among these fortunate Negroes there was in Guatemala, in the seventeenth century, a freedman who had accumulated much wealth. He had secured his liberty by paying his kind master a handsome sum for his freedom. There-

A thrifty freedman in Guatemala. after he bought a large farm and considerably increased his holdings by making other purchases. He lived in Agua Caliente, a little Indian village on the road to the city of Guatemala, in that part of the country then said to abound with gold, a treasure which the Spaniards had for many years sought in vain. Although the sources of this Negro's wealth were cattle, sheep, goats, and his trade in butter and cheese with the City of Guatemala, the Spaniards persisted in believing that his wealth came from the hidden treasure.¹³

In his travels through this tropical region, Sir Thomas Gage found a still more interesting Negro of this class. While sailing along the Atlantic coast of Costa Rica, Gage's **The Black Corsair.** ship was captured by two corsairs under the flag of the Dutch, who were then struggling against Spain for their freedom. The commander of this ship was a mulatto named Diaguillo, a native of Havana, where his mother then lived. Because of maltreatment by the Governor of Campeche, to whom he was attached as a servant, this mulatto desperately ventured to swim to one of the Dutch ships near-by. Offering himself to serve the Dutch against those who had abused him, he easily ingratiated himself into their favor. Soon thereafter he married a Dutch girl and arose to the position of captain of a vessel under the command of the famous and dreadful commander named Pie de Palo. Coming aboard the ship on which Gage was sailing, the corsair took four thousand pesos worth of jewelry and pearls and deprived the individuals of their personal belongings. But because of Gage's

¹³ *The Journal of Negro History*, Vol. I, p. 395; and Sir Thomas Gage's *Voyages*, Part 3, Ch. II.

ministerial profession Diaguillo permitted him to retain some books, pictures and clothes, saying to him, "If fortune to-day is on my side, to-morrow it will be on yours, and what I have won to-day, that I may lose to-morrow." Diaguillo then prepared a luxurious dinner, to which he invited Thomas Gage. Thereafter he took leave of the captives, thanking the crew for the good luck they had procured him.¹⁴

The most interesting example of the enlightened Negro of this class in the West Indies was Francis Williams, the son of one John Williams, liberated in 1708, and ranked among those persons in the island against whom slave testimony was forbidden. These same privileges then extended to other mem-

**Francis
Williams,
the scholar.**

bers of his family, and attached to them unusual importance among the white people with whom they moved socially. We have much more information about his son Francis. The family was of such good report, and the youth Francis had exhibited so many evidences of mental capacity, that early in the eighteenth century the Duke of Montague, desiring to put to test some of his opinions about the capabilities of the Negro, had Francis instructed in an elementary school in Jamaica and then sent to an English grammar school to prepare for Cambridge University. After some years Francis Williams completed his education at that institution and returned to Jamaica between 1738 and 1748.

Impressed more than ever with the truth that a Negro trained in the same way as a white man will exhibit the same intellectual attainments, the Duke of Montague sought further to advance his protégé by securing for him a seat in the Jamaica Council. This proposition, **The Duke of** however, was opposed by Governor Trelawny, **Montague.** who contended that admitting a black man to the Council

¹⁴ *The Journal of Negro History*, Vol. I, p. 395; and Sir Thomas Gage's *Voyages*, Part 3, Ch. II.

would excite restlessness among the slaves. Whether or not the governor was diplomatic or prejudiced is not known. He did add a Negro detachment to the army employed in Jamaica but he never permitted the ambitious youth to sit in the Council. Williams settled in Spanish Town, the capital of the island, and during the rest of his life conducted a classical school. In this position he made a reputation for himself as a schoolmaster and figured somewhat prominently as a poet. The only evidence of his attainments in this field, however, consists of a Latin poem which conforms in most respects to the standard of that age. It seemed, however, that the poet was not very popular among his own people, as he was regarded as haughty and opinionated, treating his fellow blacks with contempt and entertaining a rather high opinion of his own knowledge. He was also charged with being a sycophant and racial toady who said and did much to do his race harm.¹⁵

This better situation of a few Negroes was due also to the fact that a large number of slaves in remote parts of the West Indies and Latin-America asserted themselves and **The Maroons**, escaped to uninhabited districts to declare and maintain their independence rather than bear the yoke of bondage. In parts where the Negroes were as numerous as the whites, these fugitives often jeopardized the very life of the colony. As such, they were known as Maroons. They had few arms that the primitive man did not possess, but because of their resourcefulness and power in military organization they became a source of much terror throughout Latin-America.¹⁶ In the small colony of Guatemala in the seventeenth century there were as many as three hun-

¹⁵ The career of Francis Williams is treated in *The Journal of Negro History*, Vol. II, pp. 146-159. A better account may be found in William James Gardner's *History of Jamaica*, p. 31; and in Edward Long's *History of Jamaica*, p. 234.

¹⁶ Dallas, *History of Maroons*, p. 26.

dred such Negroes who had resorted to the woods and could not be subdued by the forces sent against them.

The greatest enterprise of the Maroons, however, was exhibited not by any particular individual but rather by that of the little Negro Republic in Brazil, called Palmares, styled by Professor Charles E. Chapman as **The Negro Numantia**, because its career resembles so much that of Numantia against which the Romans fought for a number of years before they could invade the beleaguered city. Because of the bad treatment of the Portuguese slaves, many of those imported from Guinea escaped to the forests, where they established villages called *quilombos*, the type to which Palmares, in the Province of Pernambuco, belonged. It was not long, however, before this town extended its sway over a number of others settled by persons of the same antecedents. At one time it was reported to have a population of twenty thousand, with ten thousand fighting men. Palmares, the name also of the capital of the republic, was surrounded by wooden walls made of the trunks of trees and entered by huge gates provided with facilities for wide surveillance and sentry service.

In the course of time the population of this village gradually increased because of the eagerness of slaves and freemen to try their fortunes in the forests. In the beginning they maintained themselves by a sort of banditry, taking food, slaves and women, whether mulatto, black, or white. They later settled down to agriculture, and established seemingly peaceful trade relations with the Portuguese settlements in the less hostile parts of Brazil. Palmares then developed into a sort of nation, uniting the desirable features of the republican and monarchial form of government, presided over by a chief executive called the *Zombe*, who ruled with absolute

authority during life. "The right to candidacy," says Professor Chapman, "was restricted to a group recognized as composing the bravest men of the community. Any man in the state might aspire to this dignity providing he had Negro blood in his veins. There were other officers, both of a military and a civil character. In the interest of good order the *Zombes* made laws imposing the death penalty for murder, adultery and robbery. Influenced by their antecedents, slavery was not discontinued, but a premium was placed on freedom in that every Negro who won his freedom by a successful flight to Palmares remained free, whereas those who were captured as slaves continued as such in Palmares."

This Negro Republic, however, was in the eyes of the Portuguese an unnatural growth. It was considered a resort for undesirable aliens who constituted an ever-increasing danger to the prosperity of Brazil. In 1698, therefore, Governor Caetano de Mello of Pernambuco ordered an expedition to proceed against the city. These brave blacks met the invading forces and indisputably defeated them. Returning later, however, with a formidable army of seven thousand men under the command of a more competent soldier and provided, too, with adequate artillery, the Portuguese reached the city after some difficulty and placed it in a state of siege. The defense of this city was heroic. "After the Portuguese had breached the walls in three places," says the annalist, "their infantry attacked in force. They entered the city, but had to take it foot by foot. At last the defenders came to the center of Palmares where a high cliff impeded further retreat. Death or surrender were the only alternatives. Seeing that his cause was lost beyond repair, the *Zombè* hurled himself over the cliff, and his action was followed by the most distinguished of his fighting men. Some persons were indeed taken, but it is perhaps a tribute to

**The
destruction
of Palmares.**

Palmares, though a grewsome one, that they were all put to death; it was not safe to enslave these men, despite the value of their labor. Thus passed Palmares, the Negro Numantia, most famous and greatest of the Brazilian *quilombos*." ¹⁷

¹⁷ *The Journal of Negro History*, Vol. III, pp. 31-32.

CHAPTER III

SLAVERY IN ITS MILD FORM

THE system of exploiting Africans in the West Indies did not reach the slave States until the cotton gin and other mechanical appliances instrumental in effecting the industrial revolution made slavery seemingly profitable in the United States through the cotton plantation system resulting therefrom.¹ The first slaves brought to the American colonies were few, and they served largely as house servants, so closely attached to the homes of their masters that they were treated like members of the families. No restriction on the mental development of the slaves was therefore devised, as it was deemed necessary to effect in them whatever speedy improvement was possible, with a view to increasing their efficiency.

In the course of time the number of slaves decidedly increased in certain colonies devoted to agriculture. There were about 6,000 slaves in Virginia in 1700, and they so rapidly multiplied as factors in the widely extending tobacco culture that in 1760 one-half of the inhabitants of that colony were slaves. To supply the need for cheap labor in the production of rice and indigo, the blacks in-

¹ Slavery in its first form is briefly treated in Channing's *History of the United States*, II, 336-400, and in A. B. Hart's *Slavery and Abolition*, Ch. IV. The slaves' opportunities for enlightenment are presented in C. G. Woodson's *The Education of the Negro Prior to 1861*, 18-150. See also Bryan Edwards' *History of the West Indies*; Sir Harry Johnston's *The Negro in the New World*; and the *Journal of Negro History*, I, 132-150, 163-216, 243-264, 399-435; II, 78-82, 105-125, 186-191, 229-251, 411-422, 429-430; III, 1-21, 22-28, 33-44, 45-54, 55-89, 211-328, 335-353, 381-434.

creased so fast in South Carolina after 1730 that slaves soon exceeded the whites and outnumbered them two to one in 1760. This increase tended to degrade the position of the white servant, to "cause pride and ruin the industry of our white people, who, seeing the race of poor creatures below them, looked down upon them as if they were slaves." In 1756 Andrew Burnaby reported that the people of Virginia hardly regarded the Indians and Negroes as human beings, and that it was almost impossible to convict a white man for killing a Negro or an Indian.²

There were not many slaves in the northern part of the



THE DASH FOR LIBERTY

United States. Pennsylvania had a considerable number, however, for William Penn himself owned slaves. A few toiled on the farms along the Hudson, and the number in the city of New York reached **Few slaves in the North.**

6,000 when the whole population was 40,000. Boston was one of the centers in New England to which some Negroes were brought, but a still larger number doubtless landed at the

ports connecting more closely with the West Indies. Many of these went to Newport and thence they gradually scattered to other points. In 1748 South Kingston had 1,405 whites, 381 Negroes and 193 Indians. New England, however, because of its economic condition, never became the home of many slaves; for in 1770, when there were 697,624 slaves in the thirteen States, only 3,763 of these were in

² Andrew Burnaby, *Travels Through North America*, p. 31.

New England. At that time 36,323 of the slave population lived in the Middle States and 656,538 in the South.

The Negroes, however, did not yield to this system without resistance. In New York, in 1712, an insurrection of slaves grew to such an extent that, had it not been for timely aid from the garrison, the city would have been burned. Whites were attacked in their homes and on the streets by the blacks in Charleston, South Carolina, in 1720. In 1730 many slaves in this colony actually armed and embodied to destroy the whites. Two hundred Negroes assembled near the mouth of the Rappahannock River, Virginia, to kill the white people in a church, but when the plot was discovered they fled. In 1723 some desperate Negroes planned to burn the city of Boston, and so much fear was expected that the city had to take extra precaution against "Indians, Negro or Mulatto Servants, or Slaves." A number of Negroes arose against their masters in Savannah, Georgia, in 1788, but fled when twice fired upon, as they were already disconcerted by a disagreement as to time.

In Williamsburg, Virginia, there occurred an insurrection of the blacks in 1730, occasioned by the rumor that Governor Spottswood had arrived with instructions to free all persons who had been baptized. Five counties sent forth armed men with orders to kill the slaves if they refused to submit. That year a Negro in Malden, Massachusetts, plundered and burned his master's home because he was sold to a man in Salem, whom he disliked. In 1731 slaves being imported from Guinea by George Scott of Rhode Island asserted themselves and murdered three of the crew. Captain John Major of Portsmouth, New Hampshire, in charge of a cargo of slaves, was murdered with all of his crew the following year by slaves carried on this same route. Captain Beers of Rhode Island, and all his unfortunate coworkers except

**Eighteenth
Century
uprisings.**

two, suffered the same fate when on a similar voyage a few years later.³

In 1741 there broke out a formidable insurrection of slaves in New York City. To repress this uprising thirteen slaves were burned alive, eighteen were hanged, and eighty transported. Two of those exiled were sent to the West Indies, and it became a custom thereafter **The New York Plot of 1741.** for persons having "any Negro men, strong and hearty, though not of the best moral character," to

IL s'est enfui de chez les Souffignés, la nuit du 12 du courant, Un Nègre Esclave nommé POMPEY, d'environ cinq pieds cinq pouces d'hauteur, robuste; il a été acheté dernièrement de M. Perras, négociant de cette ville; il avoit sur lui quand il a décampé un gilet et des culottes brunes: Celui qui le ramenera aura HUIT PIASTRES de Récompense, et les frais raisonnables qu'il aura faits. Qui-conque le retirera chez lui sera poursoivi suivant la dernière rigueur de la Loi, par

JOHNSTON & PURSS.



RUN-AWAY from the Subscribers, in the Night of the 12th Inst. a Sailor Negro Slave named POMPEY, about 5 Feet 5 Inches high, and is Robust; he was lately bought of Mr. Perras, Merchant in this Town; had on when he went away a brown Jacket and Breeches. Whoever brings him to the Subscribers shall have EIGHT DOLLARS Reward, and reasonable Charges paid. Any Person harbouring him will be prosecuted according to the utmost Rigour of the Law, by

JOHNSTON & PURSS.

AN ADVERTISEMENT OF A RUNAWAY SLAVE

brand them as subjects of transportation to the West Indies. In 1754 C. Croft of Charleston, South Carolina, had two of his female Negroes burned alive because they set fire to his buildings. In 1755 Mark and Phillis, slaves of John Codman of Charleston, having learned that their master had by his will made them free, poisoned him that they might expedite the matter. Mark was hanged and Phillis was burned alive.⁴

³ What the first slaves did to get rid of their masters is sketched in Joshua Coffin's *Slave Insurrections*.

⁴ *Ibid.*, p. 8.

In spite of these uprisings, however, the slave population continued to increase, and this result was not strange; for in 1770 there were in England itself not less than 15,000 slaves brought in by traders as attendants and servants. There was no decided check to this influx until the famous Somerset decision. Somerset had run away from his master in Virginia. When captured he was to be shipped to Jamaica, where he was to be sold. A writ was procured by Gran-

Slavery in England.

ville Sharp, however, and there followed a hearing which finally brought the question before Lord Mansfield, who gave the opinion

The Somerset decision.

that the state of a slave is so odious that it can be supported only by positive law to that effect, which did not exist in England.⁵ He therefore ordered the slave to be discharged. Liberal as this decision was, however, it did not seem



GRANVILLE SHARP

to have any effect on the colonies, although the struggle for the rights of man in this country tended to do much to direct attention to the condition of the Negro.

There were then in the American colonies many slaves whose condition constituted an exception to the rule, and the slaves as a whole were much better treated at that time than they were during the nineteenth century.

Exceptional slaves.

Most of them were given some opportunity for enlightenment and religious instruction. Embracing these opportunities, many of them early estab-

⁵ Hurd, *Freedom and Bondage*, I, 189-191.

lished themselves as freemen, constituting an essential factor in the economic life of their communities. Some became artisans of peculiar skill, others obtained the position of contractors, and not a few became planters themselves, owning extensive estates and numbers of slaves. Sir Thomas Gage found a number of such planters of color in Guatemala in the seventeenth century; the mixed breeds of Louisiana afforded a number of this type, and the English colonies along the coast were no exception to this rule. John Cassor, probably one of the Negroes brought over by the Dutch in 1619, became an owner of slaves in Virginia. Andrew Bryan, a Negro Baptist preacher, was widely known as a slaveholder in Savannah, Georgia, before 1790.

This attitude resulted largely from the number of white men who became interested in the welfare of the Negroes during the seventeenth and eighteenth centuries. Among these were Paul le June, a Jesuit missionary **The clergy and the blacks.** in Canada, Le Petit and François Phillibert Watrum of the same sect in Louisiana, Alphonso Sandoval in Havana, Morgan Goodwyn in Virginia, Thomas Bacon in Maryland, and George Keith in Pennsylvania. Some of these liberal workers coöperated with the Society for the Propagation of the Gospel in Foreign Parts, to which the Negroes were indebted for most of their early enlightenment. These reformers contended that the gospel was sent also to the slaves, who should be prepared by mental development to receive it. With the increasing interest in education, it became more restricted to the clergy and such other well chosen persons recommended by them and attached to the churches. The impetus given the propagation of the gospel among the crude colonists settling in America resulted also in the proselyting of the Negroes who were then being brought from the jungles of Africa in increasing numbers. It was soon evident, however, that little could be effected in the enlightenment of these blacks without first

teaching them the English language. In almost every case, therefore, during the eighteenth century, when the clergy undertook the teaching of the gospel among the blacks, it involved also extensive instruction in the fundamentals of education, that their message might have the desired effect.⁶

There was, therefore, in America during the eighteenth century, a sort of slavery differing materially from that of the nineteenth.⁷ In fact, the Negroes were about as well

**Eighteenth
Century
slavery.**

provided with schools as the whites in some of the colonies. The first school for the education of the whites in the Carolinas was established in 1716, and a school for the education of the Negroes was established about one generation later. There were in a few colonies, schools not only for free Negroes but for slaves, who were sometimes taught in the classes with the children of their masters. In some cases, when the Negroes experienced sufficient mental development to qualify as teachers themselves, they were called upon to serve their masters' children in this capacity. There were schools for Negroes in almost all of the cities and towns where they were found.⁸

It was fortunate for the Negroes that many schools of the middle colonies were conducted by the indentured servant class of low estate. It looks rather strange that our

**Convicts as
teachers.**

fathers should commit to the care of the convicts, who had been taken from the prisons in England and indentured in America, the task of educating their children. Yet this was the case. Jonathan Boucher said, in 1773, that two-thirds of the teachers in the colony of Maryland were such felons.⁹ As these were despised by

⁶ *The Journal of Negro History*, I, 87, 233, 361, and 492, and II, 51.

⁷ Woodson, *Education of the Negro Prior to 1861*, Chapter II.

⁸ *Ibid.*, 10 to 150.

⁹ Jonathan Boucher, *A View of Causes and Consequences of the American Revolution*, 39.

the whites of the higher classes, they were forced to associate with the Negroes, who learned from them how to read and write and were thereby prepared to enlighten their own fellow-men.

The location of some of these schools established for Negroes will be of much interest. Samuel Thomas undertook the instruction of certain Negroes in the Goose Creek Parish in Charleston, South Carolina, in 1695. A **Early schools for Negroes.** school for the more extensive instruction of the Negroes was established there in 1744, with Harry and Andrew, the first of the Negro race to be employed as teachers in America. Further interest was shown in the enlightenment of the slaves in that section by gentlemen and ladies of consequence, and especially by Eliza Lucas, later the wife of the renowned Justice Pinckney. The Rev. Mr. Davies devoted much of his time to this work among the Negroes in Virginia, as did Hugh Neill and William Sturgeon, ministers in Pennsylvania. Elias Neau had a school for Negroes in New York as early as 1706, and Anthony Benezet began to hold evening classes for them in Philadelphia in 1750. The settlers of New England then tolerated the instruction of the slaves along with their own children.

The evidences of the mental development of the Negroes of that day are found in the words of the masters themselves. In offering slaves for sale and advertising for fugitives, masters spoke of their virtues as well **Intellectual development.** as their shortcomings. Judging from what they said about them in these advertisements, one must conclude that many of the eighteenth century slaves had taken over modern civilization and had made themselves useful and skilled laborers, with a knowledge of the modern languages, the fundamentals of mathematics and science, and acquaintance with some of the professions. It was a common thing to refer to a slave as

being smart and exhibiting evidences of having experienced most of that mental development which usually results from what we now call a common school education. Some spoke "good English," in contradistinction to others who spoke "very much broken English." In other cases the fugitive would be credited with speaking "proper English" or speaking "very properly."

Brought in from the West Indies, where they had been in contact with all nationalities of Europe and had not been restricted in their development, many of these slaves had picked up more than the mere fragments of education.

Slaves with some knowledge. It was not unusual to find a slave speaking Spanish, French and English—and exceedingly good English. William Moore had a slave who spoke Swedish and English well. Philip French of Philadelphia had another who spoke Dutch and good English, and John Williams, of the same state, owned a Negro who spoke very good English and was very fluent in his talk. Another type of this sort was a slave who escaped from Charleston in 1799. He spoke both French and English fluently, was very artful, and succeeded in passing as a free man. A better example was a slave of Thomas May of Maryland, whom his master considered plausible and complacent. He could speak good English, a little French and a few words of High Dutch. He had been in the West Indies and in Canada, serving as a waiting-man to a gentleman, and had thereby had the opportunity of getting acquainted with the different parts of America.

In addition to the mere knowledge of how to express themselves fluently in the modern tongues, a considerable number of the fugitives advertised in some parts had learned to read and write. Advertising for a Negro named Cato, Joseph Hale said that **Slaves able to read and write.** "he speaks good English and can read and write." Another said, "he is an artfull fellow and can read

and write, and it is probable that he may endeavor to make his escape out of the Province." And still another was described in the terms, "He can read and write and it is likely that he may have a counterfeit pass." An examination of hundreds of advertisements for fugitive slaves during the eighteenth century shows that almost a third of them could read and write.¹⁰

Another evidence as to the favorable condition of the Negroes during the eighteenth century is their economic condition. The kind of garments they wore and the manner in which they lived throw much light on this situation. In some cases they lived in houses, enjoying the same comforts as their masters. In other cases their quarters were much better than those then provided for the poor whites in Europe and for the indentured servants in the colonies, as some masters did not take much care of such laborers, since, when their term of service expired, they would no longer be of use to them.

According to the testimony of many masters in the advertisements for fugitives, they were in most cases well attired. For example, a master of Philadelphia in 1721 said that his slave escaped, wearing "a dark brown colored coat and jacket, a pair of white fustian breeches, a **Slaves well dressed.** gray milled cap with a red border, a pair of new yarn stockings with a pair of brown worsted under them or in his pockets." A slave owner in Maryland spoke of another fugitive as having "a black cloth coat, a high hat, white flannel waistcoat, a checked shirt, a pair of everlasting breeches, a pair of yarn stockings, a pair of old pumps, a worsted cap, an old castor hat, and sundry other clothes." A Boston master in 1761 lost a slave, who had, "when he went away, a beaver hat, a green worsted coat, a close-bodied coat with a green narrow frieze cape, a gray coat, a

¹⁰ For a treatment of the eighteenth century slave see *The Journal of Negro History*, I, 175-189.

black and white homespun jacket, a flannel checked shirt, gray yarn stockings, a flannel shirt, a bundle of other clothes, and a violin." White persons at that time were not generally better clad.¹¹

In not a few other cases these fugitives are mentioned as persons who had not only an ample supply of clothing, but considerable money. John Dulin of Baltimore, in 1793, advertised for a slave supplied with ample funds, and

**Slaves in
good circum-
stances.**

the context of the advertisement indicates that the money was earned by the slave while hiring his time. Referring to another fugitive, a master said: "As I expect he has a sum of money with him, probably he may get some one to forge a pass for him and pass as a free man." Some Negroes were widely known, as they were serving as mechanics and artisans, and a few of them became contractors on their own account, overseers for their masters, and finally freemen established in business for themselves.¹²

In the absence of restrictions which characterized the economic slavery of the following century, they had entered many of the higher pursuits. Some of these Negroes were serving as teachers and preachers, and a few were engaged

**Slaves in
higher
pursuits.**

in the practice of medicine, as was then common in this country. Referring to one of his slaves, in 1740, James Leonard of Philadelphia said he could "bleed and draw teeth, pretending to be a great doctor and very religious, and he says he is a churchman." In 1797 James George of Charleston, South Carolina, had a slave who passed for a doctor among his people and, it was supposed, practiced in that capacity about town. Negroes were serving as privateers and soldiers in the army during the colonial wars and had learned so much about the military contests for possession in the new world that the

¹¹ *The Journal of Negro History*, I, 203.

¹² *Ibid.*, 203.

English feared that close relations between the French in the West and the slaves of the colonies along the coast might eventually lead to an understanding between the French and the slaves to the effect that the latter might cross the mountains into French territory.

Probably the most striking evidences of the favorable situation of the slaves during the eighteenth century is



THE PUNISHMENT OF A RUNAWAY SLAVE

their close relation with the poor whites, the most of whom, at that time, were indentured servants. Reduced to the same social status by common lot in servitude, these two classes were in many cases, especially in the colonies around the Chesapeake Bay, about equally treated. The slaves and the indentured servants followed the same occupations, had the same privileges and facilities, and experienced together the same pleasures.

Living on this common plane, these two classes soon proceeded to intermarry. In 1720 Richard Tilghman of Philadelphia complained that his mulatto slave, Richard Molson, had run away in company with a white woman named Mary, who, it was supposed, passed as his wife, and with a white man named Garrett Choise, and Jane, his wife. A mulatto servant man in Philadelphia named Isaac Cromwell ran away with an English servant woman named Anne Greene, in 1745. Two years later, Ann Wainrite, a servant woman of New Castle County, ran away, taking with her a Negro woman.¹³

These close relations between the blacks and the indentured servants later caused unusual dissatisfaction. Laws were therefore enacted to prevent this interbreeding of the races. In 1661 the preamble of such a law in Maryland said, "And forasmuch as divers freeborn **Dissatis-
faction.** *English* women, forgetful of their free condition, and to the disgrace of our nation, do intermarry with negro slaves, by which also divers suits may arise, touching the issue of such women, and a great damage doth befall the master of such Negroes, for the prevention whereof, for deterring such free-born women from such shameful matches, *be it enacted:* That whatsoever free-born women shall intermarry with any slave, from and after the last day of the present assembly shall serve the master of such slave during the life of her husband; and that all the issues of such free-born women so married, shall be slaves as their fathers were. And be it further enacted: That all the issues of *English*, or other free-born women, that have already married Negroes shall serve the master of their parents, till they be thirty years of age and no longer."¹⁴

This, however, did not seem to prevent the miscegenation

¹³ *The Journal of Negro History*, I, 206.

¹⁴ This social status is more extensively treated in *The Journal of Negro History*, I, 206-216, and II, 335-353.

of the two races, for planters sometimes married white women servants to Negroes in order to transform such servants and their offspring into slaves. This happened in the case of Irish Nell, a servant woman brought to Maryland by Lord Baltimore and sold later to a planter when the proprietor returned to England. The proceedings instituted to obtain freedom for her offspring by her Negro husband occupied the attention of the courts of Maryland for a number of years, after which the petition was finally granted. This procedure was especially legislated against in 1681, by a measure which penalized this custom then obtaining among the planters. The interbreeding of the races, however, in spite of the laws against it, continued. The public was burdened with so many illegitimate mulatto children that it became necessary to frame laws compelling the persons responsible to maintain these unfortunate waifs, and making the Negroes or the white persons concerned servants or slaves for a certain number of years.

In Virginia it was necessary to take the same action. Hugh Davis was whipped there in 1630 because he was guilty of defiling his body by lying with a Negro. In 1622 the colony imposed fines for fornication with a Negro, but did not restrict intermarriage until 1691. According to this law, if any free English woman should have a bastard child by a Negro or mulatto, she should pay the sum of fifteen pounds sterling, and in default of such payment she should be taken into the possession of the church wardens and disposed of for five years, and such illegitimate children should be bound out as servants until they reached the age of thirty. If the woman in question happened to be already in servitude, five years were added to the term for which she was then bound. This same law was further elaborated and extended by the Virginia law of 1753. Here, however, it developed, just as

Miscegenation.

Efforts to separate the races.

in the case of Maryland, that these laws failed to remedy the prevailing evil, and that State found itself with an unusually large number of illegitimate mulatto children on its hands. The officials hit upon the plan of binding them out, as was done in the case of David James in 1727, one Malachi on a plantation, and another free Negro in Norfolk County in 1770.



ENTERTAINMENT

North Carolina also undertook to put an end to this miscegenation. That colony provided in 1715 for the usual laws restricting the intercourse of the two races. Clergymen officiating at mixed marriages were penalized. These precautions, however, failed to meet the requirements, and the custom continued in North Carolina just as it had elsewhere, in spite of the fact that the law of 1741 legislated against "that abominable mixture and spurious issue,

which hereafter may increase in this government by white men and women intermarrying with Indians, Negroes, Mulattoes or Mustees." It was enacted that if any man or woman, being free, should intermarry with such persons, he should be fined fifty pounds for the use of the parish, and any white servant woman found guilty of such conduct should have two years of service in addition to the time for which she was already bound out.

This custom obtained in other parts where the Negroes were found in smaller numbers, and because of the scarcity of such population was checked with greater difficulty. Massachusetts enacted a law against it in 1705. Pennsylvania took action in 1725. These laws were extended and made more rigid in the course of time, as the custom gave more and more dissatisfaction. It was a long time, however, before it had very much effect in New York, and still longer in Pennsylvania. This intermixture endured, and when in 1780, during the struggle for the rights of man, this law was repealed, mixed marriages became common. But when the ardor of the revolutionary leaders had become much diminished towards the close of the eighteenth century, there set in a decided reaction against this miscegenation. It was therefore extensively agitated throughout communities where Negroes were found in large numbers, and various petitions came from those sections praying that intermarriage of the whites and blacks be prohibited. The first petition of consequence came from Green County in 1820. Such a marriage was the cause of a riot in Columbia in 1834, and another of a riot in Philadelphia in 1849. In 1838 members of the Constitutional Convention engaged in a heated discussion of the custom. The agitation, however, was generally ineffective, for race admixture continued, as is evidenced by the fact that one-fifth of

**Difficulties
in separating
the races.**

**Agitation
against
miscegenation.**

the Negroes in the State in 1800 were mulattoes and that in 1860 this proportion had increased to one-third.

Persons who professed seriously to consider the future of slavery, therefore, saw that miscegenation, and especially the concubinage of white men with their female slaves, introduced a mulatto race whose numbers would become dan-
The Danger of gerous if the affections of their white parents
miscegenation were permitted to render them free. The
to slavery.

Americans of the future would thereby become a race of mixed breeds rather than a white and a black population. As the lust of white persons for those of color was too strong to prevent race admixture, the liberty of emancipating their mulatto offspring was restricted in the slave States, but the custom of selling them became common.

These laws, therefore, eventually had their desired effect. They were never intended to prevent the miscegenation of the races, but to debase to a still lower status the offspring of the blacks, who, in spite of public opinion, might under
Laws finally other circumstances intermarry with the poor
effective. white women. The more important objective, too, was to leave the women of color without protection against white men, who might use them for convenience, while white women and black men would gradually grow separate and distinct in their social relations. Although thereafter the offspring of blacks and whites did not diminish, instead of being gradually assimilated to the type of the Caucasian they tended to constitute a peculiar class, commonly called people of color, having a higher social status than that of the blacks, but finally classified, with all other persons of African blood, as Negroes.

CHAPTER IV

THE NEGRO AND THE RIGHTS OF MAN

AFTER the patriarchal form of slavery became engrafted upon our civilization, the world-wide struggle for the rights of man worked a decided improvement in the condition of the Negro. There had always been some opposition to slavery from the very time it was first introduced.¹ The founders of Pennsylvania undertook to rid that colony of the perpetual servitude of the imported blacks by providing that the children should become free at the age of fourteen. Efforts were at first made to keep the institution out of Georgia, for the reason that slaves were not vigorous enough to furnish defense for a frontier colony and would starve the poor white laborers. William Usselinx proposed to prohibit its introduction in the Swedish colonies, because African slave labor would be less profitable than that of the Europeans.

More striking than these arguments were those of the Puritans and Quakers, based on religious principles. The religious element believed in slavery as connected in some way with religion. Although not advocates of social equality for the blacks, the New England colonists believed in equality before God

Early objections to slavery.

Religious bodies opposed slavery.

¹ For a lengthy discussion see M. S. Locke's *Antislavery in America from the Introduction of the African Slaves to the Prohibition of the Slave Trade*, pp. 1-157; and C. G. Woodson's *The Education of the Negro Prior to 1861*, Ch. III. Valuable information may be obtained from *The Journal of Negro History*, Vol. I, pp. 49-68; Vol. II, pp. 37-50, 83-95, 126-138.

and, therefore, in the freedom of the body. Having the same idea, Roger Williams protested against the enslavement of Pequot Indians in 1637. John Eliot and Cotton Mather attacked the institution because of its abuses. In 1701 Justice Sewell presented his convincing argument against it in his essay entitled *The Selling of Joseph*. The Puritans felt that slavery was the particular offense that called down the avenging wrath of God, and not wishing to make money of it, sought at first to restrict it to lawful captives taken in just wars. They felt that it was perilous to salvation in that the souls of the captives were often neglected.

Among the Quakers, who unlike the Puritans, believed in social equality as well as equality before God, the anti-slavery movement met with more success. The Quakers noticed especially the cruel treatment of slaves and the vices resulting from the system. They also endeavored to prove that the system was prejudicial to the interests of all in that it prevented the poor whites from finding employment, promoted idleness among the rich, cut off the immigration of industrious Europeans, and precluded the prosperity of whites already in the land.

These religious antislavery attacks, of course, were met by various other arguments. Some said that Negroes were slaves because of the curse of Canaan; others because they were ignorant and wicked, and might, therefore, rejoice over their opportunity to be led to Christ through enslavement by the Christian white race. Ralph Sandiford inquired: "If these Negroes are slaves of slaves, whose slaves must their masters be?"² Elihu Coleman, replying to the argument that Negroes should be enslaved because of their wickedness, said: "If that plea would do, I believe that they need not go far

² Ralph Sandiford, *Brief Examination*, Ch. IV, p. 5.

for slaves as now they do.”³ Seeing that the difference of race was the main thing, the Quakers of Germantown, Pennsylvania, said: “Now, though they are black, we cannot conceive there is more liberty to have them slaves, than it is to have other white ones. There is a saying that we shall do to all men like as we will be done to ourselves, making no difference of what generation, descent or color they are. Here is liberty of conscience which is right and reasonable. Here ought also to be liberty of the body.”⁴ This argument was further elaborated by George Keith, John Hepburn, William Burling and Benjamin Lay, all of whom were men of influence in shaping the thought of the Quakers.

This protest against slavery tended to become more and more religious. Sandiford said: “Shall we go to Africa for bread and lay the burden which appertains to our bodily support on their shoulders? Is this washing one another’s feet, or living by the Gospel, or **Ralph Sandiford’s** maintaining liberty and property? And to **ford’s** attack. live on another’s labor by force and oppression, is this loving mercy? And to keep them slaves to us and our posterity to all eternity, is this walking humbly with God?”⁵ Denouncing all slaveholders as sinners, Benjamin Lay said: “Slaves are bound to them; so are they to the **Benjamin Lay** Devil, and stronger, for as death loosens one, it fastens the other in eternal Torment if not repented and forsaken.” He styled as a sort of devils that preach to hell rather than to Heaven those ministers who, in leaving their homes on Sunday to preach the “Gospel of glad tidings to all men and liberty to the captives, directed the slaves to

³ Elihu Coleman, *Testimony*, p. 17.

⁴ *Germantown Friends’ Protest against Slavery* in A. B. Hart’s *American History Told by Contemporaries*, Vol. II, section 102, pp. 291-293.

⁵ Ralph Sandiford’s *Brief Examination*.

work to maintain them in pride, idleness, laziness and fullness of bread, and sins of Sodom." 6

These arguments were not merely empty protests but ideas translated into action by the Quakers. They promoted manumission by individual owners, and by 1713 **Manumission promoted.** worked out a definite scheme for the liberation of the Africans and their restoration to their native land, after having been prepared beforehand by instruction in religion and the fundamentals of education. Their protests against the purchase of Africans seriously impaired the market for slaves in Philadelphia by 1715, and decidedly checked the importation of slaves into Pennsylvania in 1743.

In later years the work of the Quakers became more effective. Most of the slaves of Quakers in New England and the Middle States were by moral suasion and religious coercion manumitted by the time of the American Revolution and in the Southern States not long after the close of the century. No such effective work was accomplished by any other body of Christians. Among the Congregationalists there were heard such protests as that of Samuel Hopkins of Newport and that of Ezra Stiles, the President of Yale College. Samuel Webster of Salisbury, and Nathaniel Niles and William Gordon of Roxbury also attacked the evil, but their group did not then make an organized effort for the extermination of the system.

These efforts in later years became more successful, not so much because of the forceful preachments of the sects but on account of the new impetus given the movement by forces set to work during the period following the French and Indian War and culminating in the spread of the nascent social doctrine which effected the American Revolution. The Brit-

After the French and Indian War.

6 Benjamin Lay, *All Slave-Keepers Apostates*, pp. 92-93.

ish, as a result of the military triumph of Wolfe at Quebec and Clive in India, had come into possession of vast territory. Parliament, under the leadership of Grenville, Townshend and North, hoped to incorporate these conquests into the empire and compel them to defray the expenses incident to the execution of the plan by enforcing the Navigation Acts, which had all but fallen into desuetude. Long since accustomed to freedom from such restraint, the colonists began to seek in law and history facts with which they disputed the right of Parliament to tax America, and on the basis of which they set forth theories justifying the religious, economic and political freedom of man.

During this period the colonists of the more democratic order obtained first toleration and finally religious freedom for their more popular sects. These were the Quakers, Methodists, Baptists and Presbyterians. Most of these at that time accepted the Negroes as human beings and undertook to accord them the privileges of men. For the Negroes this meant larger opportunities for religious development and intellectual progress, and finally, citizenship in the more liberal colonies, when political leaders imbued with the idea of the unalienable rights of man joined these religious bodies in the struggle for the freedom of the Negroes. These efforts of religious groups, formerly operating independently along parallel lines, finally culminated as one united movement when political leaders, impelled by the spirit of universal liberty, joined hands with theologians and humanitarians to translate these theories into vigorous action.

**Toleration
and the
Negro.**

In this struggle appeared some of the most forceful and logical protagonists who united the religious protests with that of the rights-of-man theory justifying universal liberty. In 1767 Nathaniel Appleton insisted that the slaves should not only "be treated with a respect agreeable" but that the institution should be abol-

**The Rights
of man.**

ished. If the West Indies, as some then contended, could not be cultivated without slave labor, "let them sink then," said he, "for it is more honorable to seek a support by begging than by theft."⁷ Anthony Benezet, a French Huguenot, who, in Philadelphia, became a member of the Society of Friends because of their antagonism to slavery, boldly attacked the institution and the slave trade as inconsistent with man's natural rights. John Woolman, one of the fathers of the Friends, carried the rights-of-man theory to its logical conclusion, insisting that liberty is the right of all men, and that slaves being fellow-creatures of their masters had a natural right to be free to discharge the functions of citizenship.

Playing their part in the antislavery drama, the Presbyterians took the position that slavery was wrong because it subjected the will of the slave to that of the master. The **Presbyterians**. Baptists often attacked the institution with such zeal that some of them became known as the Emancipating Baptists. The Methodist Episcopal Church, influenced by John Wesley, declared at its conference in 1786: "We view it as contrary to the golden law of God and the prophets, and the unalienable rights of mankind, as well as every principle of the Revolution, to hold in deepest abasement, in a more abject slavery than is perhaps to be found in any part of the world, except America, so many souls that are capable of the image of God."⁸ Strenuous efforts were then made to excommunicate slaveholders and especially those known as ministers.⁹

This success, however, was not necessarily due to the

⁷ Nathaniel Appleton, *Considerations on Slavery*, p. 19.

⁸ Lucius Matlock, *History of American Slavery and Methodism*, p. 29.

⁹ While the Quakers, however, discouraged the growth of the institution among their people, and actually exterminated it, the other sects kept the question in its agitated state until it finally divided several of them before the Civil War.

work of the clergy of the liberal sects. It was their effort supported by these political leaders who applied the principles of the Declaration of Independence to the Negro. The same theological doctrines and political theories which impelled the colonists to rise against the home country to establish the free government and religious liberty for which they left their homes in Europe, caused them also to contend that it was wrong for the whites to exploit the blacks. In many cases the foremost advocates of the rights of the colonists were also advocates of the right of the Negroes to be free, although there were many who contended that the principles of the Declaration of Independence did not apply to the Negroes, as slaves were not constituent members of our society.

Political
leaders and
the Negro.

Finding it difficult to harmonize their holding men in bondage with the assertion of the right of all men to be free, however, the revolutionary leaders boldly met the question. When James Otis was arguing the case of the Writs of Assistance, showing the immunity of the colonists from such violation of the laws of nature, he did not forget the Negroes, who, he said, should also be freed. It is little wonder, then, that John Adams, who heard the argument, shuddered at the doctrine taught and the consequences that might be derived from such premises. Patrick Henry soon discovered that his own denunciation of the clergy and other agents of royalty in America was broad enough to establish the right of the Negro to freedom, and later expressed himself accordingly.

Meeting
the issue.

Thomas Jefferson, the philosopher of the Revolution, found among other grounds for the justification of the revolt against Great Britain that the King had promoted the slave trade. Jefferson incorporated into his original draft of the Declaration of Independ-

The position
of Jefferson.

ence an indictment of George III to the effect that he had violated the "most sacred rights of life and liberty of a distant people, who never offended him, captivating them into slavery in another hemisphere or to incur miserable death in their transportation thither." Though not so outspoken, there stood with Jefferson almost all of the fathers of the American Revolution, even those in the South, like Henry Laurens, George Wythe, George Mason, and George Washington.

This new interest in the Negro during the American Revolution secured to the race an appreciable share in defending the liberty of the country.¹⁰ One cause of the Boston Massacre was that a slave, out of love of country, insulted a British officer. In the clash itself Crispus Attucks, another Negro, was one of the first four to shed blood in behalf of American liberty. During the war numbers of Negroes, like Lemuel Haynes, served as minute men and later as regulars in the ranks, side by side with white men. Peter Salem distinguished himself at Bunker Hill by killing Major Pitcairn, a number of other Negroes heroically rescued Major Samuel Lawrence, and Salem Poore of Colonel Frye's regiment acquitted himself with such honor at the battle of Charlestown that fourteen American officers commended him to the Continental Congress.

The organization of Negro soldiers on a larger scale as separate units soon followed after some opposition. The reasons for timidity in this respect are various. Having the idea that the Negroes were savages who should not be permitted to take part in a struggle between white men, Massachusetts protested against the enlistment of Negroes. The Committee of

¹⁰ This military history is well treated in W. B. Hartgrove's *The Negro Soldier in the American Revolution*, in *The Journal of Negro History*, Vol. I, pp. 110-131.

Safety, of which John Hancock and Joseph Ward were members, had the opinion that as the contest then between Great Britain and her colonies respected the liberties and privileges of the latter, the admission of any persons but freemen as soldiers would be inconsistent with the principles supported and would reflect dishonor on the colony. Although this action did not seemingly affect the enlistment of free persons of color, Washington, in taking command of

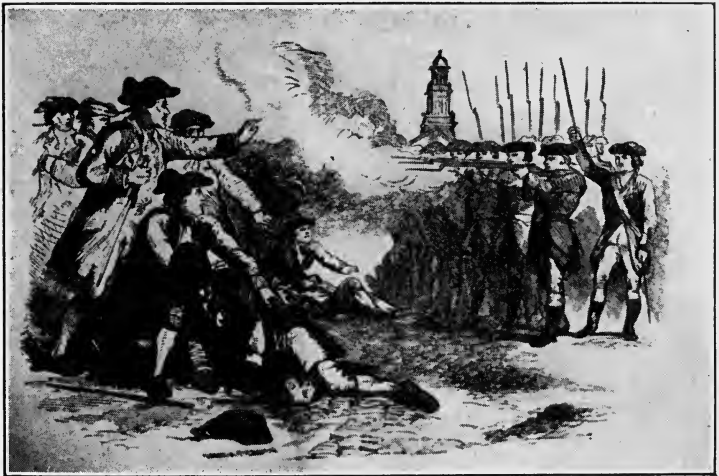

THE DEATH OF CRISPUS ATTUCKS IN THE BOSTON MASSACRE

the army at Cambridge, prohibited the enlistment of all Negroes. The matter was discussed in the Continental Congress and as a result Washington was instructed by that body to discharge all Negroes, whether slave or free. When the enlistment of Negroes came up again in the council of the army, it was unanimously agreed to reject slaves and by a large majority to refuse Negroes altogether. By these instructions, Washington, as commander of the army, was governed late in 1775.

Many of the colonists who desired to avail themselves of the support of the Negroes were afraid to set the example, thinking that the British might outstrip them in playing the same game and might arm both the Indians and Negroes faster than the colonies could. A few were of the opinion that the Negroes, seizing the opportunity, might go over to Great Britain, as was the case with the delegates from Georgia to the Continental Congress, who had grave fears for the safety of the South. They believed that if one thousand regular troops should proclaim freedom to all Negroes, twenty thousand of them would join the British in a fortnight.

As a matter of fact, they had good reason for so thinking. When Lord Dunmore, Governor of Virginia, was driven from the colony by the patriots, he summoned to his support several hundred Negroes to assist him in regaining his power, promising them freedom from their masters. The British contemplated organizing a Negro regiment in Long Island. Sir Henry Clinton proclaimed in 1779 that all Negroes in arms should be purchased from their captors for the public service and that every Negro who might desert the "Rebel Standard" should have security to follow within the British lines any occupation which he might think proper.

These plans, moreover, were in some parts actually carried out. The British made an effort to embody two Negro regiments in North Carolina. Between 1775 and 1783 the State of South Carolina lost 25,000 Negroes, who went over to the British. Probably three-fourths of all the Negroes then in Georgia were lost to the Americans. One-third of the men by whom Fort Cornwallis was garrisoned at the siege of Augusta were Negroes loyal to the English. A corps of fugitive slaves calling themselves the King of England's soldiers harassed for several years

the people living on the Savannah River, and there was much fear that the rebuffed free Negroes of New England would do the same for the colonists in their section.

It was necessary, therefore, for the leaders of the country to recede from this position of refusing to enlist Negroes. Washington within a few weeks revoked his order prohibiting their enlistment. The committee in the Continental Congress considering the matter recommended the reënlistment of those Negroes who had

**Negroes
enlisted.**

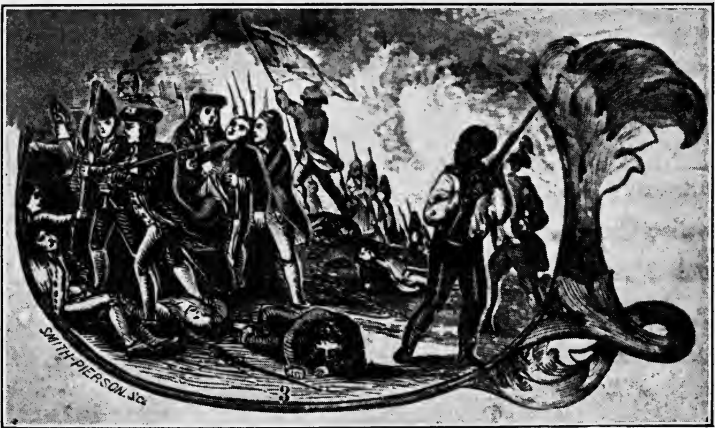

PETER SALEM AT BUNKER HILL

served faithfully, and Congress was disposed to leave the matter to the commonwealths, not wishing to infringe upon what they called States' rights. Most men of foresight, however, approved the recognition of the Negro as a soldier. James Madison suggested that the slaves be liberated and armed. Hamilton, like General Greene, urged that slaves be given their freedom with the sword, to secure their fidelity, animate their courage, and influence those remaining in bondage by an open door to their emanci-

pation. Henry Laurens of South Carolina, then in eternal dread of the disaffection of the slaves, said he would advance those who are unjustly deprived of the rights of mankind to a state which would be a proper gradation between abject slavery and perfect liberty, and would have a corps of such men uniformly clad and equipped to operate against the British. John Laurens, the son of Henry Laurens, was permitted by the Continental Congress to undertake such enlistment in South Carolina, but when he brought his plan before the legislature he was defeated by a "triple-headed monster that shed the baneful influence of avarice, prejudice and pusillanimity in all our assemblies."¹¹

In other parts of the country, however, the interest in the Negro was such that they regained the former standing in the army. Free Negroes enlisted in Virginia, and so many slaves deserted their masters for the army that the State enacted in 1777 a law providing that no Negro should be enlisted unless he had a certificate of freedom. But later many Virginia slaves, with the promise of freedom, were sent to the army as substitutes for freemen, and to prevent masters of such Negroes from reënslaving them, the State passed an act of emancipation, proclaiming freedom to all who had enlisted and served their term faithfully, and empowered them to sue in *forma pauperis*, should they thereafter be unlawfully held.

In his strait at Valley Forge, Washington was induced by General Varnum to enlist a battalion of Negroes in Rhode Island to fill his depleted ranks. The Rhode Island assembly acceded to this request, giving every effective slave the liberty to don the uniform on the condition that upon his passing muster

Solving the problem in the States.

¹¹ Sparks, *Writings of George Washington*, VIII, 322, 323.

he would become absolutely free and entitled to all the wages, bounties, and encouragements given to any other soldier. Connecticut undertook to raise a Negro regiment, and New York in 1780, promising masters the usual bounty land to purchase their slaves, proclaimed freedom to all bondmen thus enlisting for three years. This sort of action governed the enlistment of Negroes in New Hampshire, where it operated to exterminate slavery. In 1781 Maryland resolved to raise 750 Negroes to be incorporated with the other troops. Massachusetts, at the suggestion from Thomas Kench, considered the question of organizing in separate battalions the Negroes serving in the ranks among white men, thinking that in units by themselves they would exhibit a better *esprit de corps* and that a larger number would enlist; but as the suggestion led to a heated

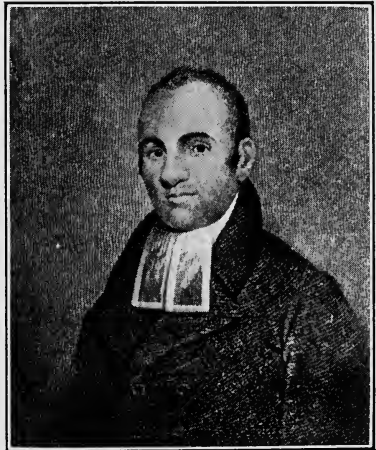

LEMUEL HAYNES, a Negro soldier in the American Revolution and later a distinguished Congregational preacher to white people in New England

debate in the legislature and to blows in the coffee houses of Boston, nothing definite was done.

In estimating the services rendered by the black troops of the American Revolution, observers and officers were loud in their praise. Speaking of the valor displayed by the Rhode Island regiment, the Marquis de Chastellux said: "At the passage of the ferry I met a detachment of the Rhode Island regiment, the same corps we had with us last summer, but they

Opinions as to Negro bravery.

The Negro In Our History

BY HIS EXCELLENCY
GEORGE WASHINGTON, ESQ;
General and Commander in Chief of the Forces of the United
States of America.

THESE are to CERTIFY that the Bearer hereof
Briston Baker Soldier
in the *Second Connecticut* Regiment, having faithfully
served the United States *from April 8th 1777 to*
June 9th 1783 and being enlisted for the War only, is
herely DISCHARGED from the American Army.

GIVEN at HEAD-QUARTERS the *9th June 1783*

By HIS EXCELLENCY'S
Command,

Thomas Bull
REGISTERED in the Books
of the Regiment,

THE above *Baker*
has been honored with the BADGE of MERIT for *his*
Years faithful Service. *W. Smith*

HEAD-QUARTERS, June *11th* 1783,

THE within CERTIFICATE shall not avail the
Bearer as a Discharge, until the Ratification of the definitive
Treaty of Peace; previous to which Time, and until Proclama-
tion thereof shall be made, He is to be considered as being on
Furlough.

GEORGE WASHINGTON

since have been recruited and clothed. The greater part of them are Negroes or mulattoes; but they are strong, robust men and those I have seen had a very good appearance." Referring to the behavior of Negroes who fought under General Greene, Lafayette said that in trying to carry the commander's position the enemy repeated the attempt three times and was often repulsed with great bravery. One hundred and forty-four of the soldiers holding this field were Negroes. Speaking of the troops who took part in the battle of Long Island, Dr. Harris, a veteran, said: "Had they been unfaithful or even given way before the enemy, all would have been lost. Three times in succession they were attacked with more desperate valor and fury by well-trained disciplined troops and three times did they successfully repel the assault, and thus preserved our army from capture." Negro troops sacrificed themselves to the last man in defending Colonel Greene in 1781 when he was attacked at Point Bridge, New York. Referring to the battle of Monmouth, Bancroft said, "Nor may history omit to record that of the Revolutionary patriots who on that day offered their lives for their country more than 700 black men fought side by side with the white." According to Lecky, "the Negroes proved excellent soldiers in a hard-fought battle that secured the retreat of Sullivan when they three times drove back a large body of Hessians."

Some of these Negro soldiers emerged from the Revolution as heroes. A Negro slave of South Carolina rendered Governor Rutledge such valuable services in this war that by special act of the legislature in 1783 his wife and children were liberated. Because of his unusual fortitude and valor in battle, the State and the people of Georgia honored Austin Dabney, a mulatto, who took a conspicuous part in many skirmishes in the South. Fighting under Elijah Clark, he was severely wounded by a bullet which in passing through his body wounded him for life. He received

a pension from the United States Government and was by an act of the legislature of Georgia given a tract of land. He subsequently accumulated considerable property, attained a position of usefulness among his white neighbors, had the respect and confidence of high officials, and died mourned by all.

The result of the increasing interest in the Negro was that with the exception of South Carolina and Georgia, a decided step forward in the extermination of slavery was taken during the revolutionary epoch. The black codes were considerably moderated and laws facilitating manumission were passed in most of the colonies. Vermont, New Hampshire and Massachusetts exterminated the institution by constitutional provision; Rhode Island, Connecticut, New Jersey, New York and Pennsylvania washed their hands of the stain by gradual emancipation acts; and the Continental Congress excluded the evil from the Northwest Territory by the Ordinance of 1787.¹² So sanguine did the friends of universal freedom become that they thought that slavery of itself would later gradually pass away in Maryland, Virginia and North Carolina.

To prepare the freedmen for this new opportunity,

¹² This prohibitory clause was:

There shall be neither slavery nor involuntary servitude in the said territory, otherwise than in the punishment of crime, whereof the party shall have been duly convicted: *Provided always*, That any person escaping into the same, from whom labor may be lawfully claimed in any one of the original States, such fugitive may be lawfully reclaimed and conveyed to the person claiming his or her labor or service as aforesaid.

Be it ordained by the authority aforesaid: That the resolutions of the 23d of April, 1784, relative to the subject of this ordinance, be, and the same are hereby, repealed, and declared null and void.

Done by the United States, in Congress assembled, the 13th day of July in the year of our Lord 1787, and of their sovereignty and independence the twelfth.

schools were established in almost all large groups in towns and cities. Efforts were made to apprentice such blacks to trades, to place them in the higher pursuits of labor, and to develop among them a class of small farmers who might be settled on unoccupied lands west of the Alleghanies. In fact, this was the halcyon day of the Negro race prior to its emancipation. Up to the closing years of the American Revolution never had so much been done in behalf of the blacks, never had there been such opportunities for developing their power to function as citizens. And so much of an impetus was then given to the cause of the Negroes that despite the reaction following this epoch they retained their citizenship intact in most parts of the North and even late in parts of the South, as was the case in North Carolina, where the Negroes voted until 1834.

The first impulse to general improvement of the Negroes came through the new sects, which in this social upheaval attained not only toleration but freedom. As there was less ground for antagonism to the development of the Negroes in this direction, many of them became socially equal with the white communicants, and some Negro churchmen trained by pious whites preached to audiences of the Caucasian race. Among these was Jacob Bishop, who so impressed his co-workers that he was at the close of the century made pastor of the first Baptist church (white) of Portsmouth, Virginia. William Lemon was at this time preaching to a white congregation at Pettsworth or Gloucester, Virginia. Some recognition by whites was given during these years to Henry Evans and Ralph Freeman of North Carolina, Harry Hosier of Philadelphia, Black Harry of St. Eustatius, and Lemuel Haynes, an intelligent Negro preacher to white people in Connecticut. Andrew Bryan, contemporary with

Preparation for emancipation.

Religious freedom.

Jacob Bishop.

Jacob Bishop, preached occasionally to the whites, but devoted his life to religious work among his own people. He

George Liele was the successor to George Liele, who, under
and Andrew the rule of the British in Savannah, had
Bryan. founded the first Baptist church of that city.

He went with them to Jamaica, where he established the first Baptist church in that colony. Bryan's task, however, was

not so easy as that of Liele.

The Americans who succeeded the British in authority at Savannah, persecuted Bryan, whipping him whenever he attempted to preach. In the course of time, however, he obtained the support of a few kind-hearted whites, who interceded in his behalf and secured for him the permission to preach without interruption. His work, thereafter, made progress, and extended to Augusta through the coöpera-



PHYLLIS WHEATLEY

tion of Henry Francis and others.

In the circle of intellectual Negroes there stood out two characters more prominent than these churchmen. These were Phyllis Wheatley¹³ and Benjamin Banneker.¹⁴ Phyllis Wheatley was a slave in a Boston family that gave her every opportunity for improvement. After receiving instruction for a few years she mastered the fundamentals of education and made unusual

¹³ R. R. Wright, *Phyllis Wheatley*.

¹⁴ Henry E. Baker, *Benjamin Banneker* in *The Journal of Negro History*, Vol. III, pp. 99-118.

advancement in the study of Latin and History. In the very beginning of her career she exhibited the tendency to write poetry. While present-day criticism would not classify her as a poet, she was, in her time, a writer of such interesting verse that she was brought into contact with some of the best thinkers of that period. All of them were not seriously impressed with her actual contribution to literature, but they had to concede that she had decidedly demonstrated that Negroes had possibilities beyond that of being the hewers of wood and drawers of water for another race.

Benjamin Banneker was a character of more genius than that with which many of his white contemporaries were endowed. Born in Maryland, of a white woman and black father, he was free, and at that time exercised most of the privileges accorded white men.

He was in a position to attend an elementary school, and upon the moving of the well known Ellicotts to his neighborhood about the time he was reaching his majority, Banneker had made such advancement in science and mathematics that Mr. George Ellicott supplied him with books. Studying these works, Banneker developed into one of the most noted astronomers and mathematicians of his time. He was the first of all Americans to make a clock, and published one of the first series of almanacs brought out in

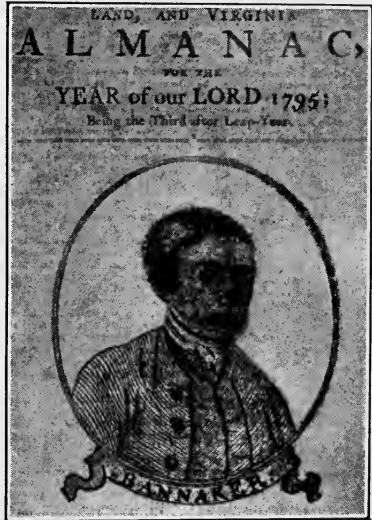

BENJAMIN BANNEKER'S ALMANAC

**Benjamin
Banneker.**

the United States. These meritorious achievements made him so prominent that he was sought and received by some of the most prominent men of the United States. Among these were James McHenry, once Vice-President of the United States; and Thomas Jefferson. The latter was so impressed with his worth that he secured for him a place on the commission that surveyed and laid out Washington in the District of Columbia.

CHAPTER V

REACTION

THE impetus given the uplift of the Negroes during the struggle for the independence of the country was gradually checked after 1783, when the States faced the problem of readjustment. In the organization of governments the States came to the conclusion that it was **Emancipation** necessary to restrain men to maintain order checked. and that they had to depart from some of the theories on which the Revolution was fought. In the elimination of the impracticable from the scheme of reconstruction after making peace with Great Britain, the proposal for the emancipation of the slaves was no longer generally heeded. In those colonies where the Negroes were not found in large numbers they were emancipated without much opposition and some of them were made citizens of the new States. But in those where the Negroes constituted a considerable part of the population there followed such a reaction against the elevation of the race to citizenship that much of the work proposed to promote their welfare and to provide for manumission was undone.¹

Certain States of the upper South did support the move-

¹ M. S. Locke, *Antislavery in America*, pp. 157-166; K. H. Porter, *A History of Suffrage in the United States*, Chs. II and III. C. G. Woodson, *The Education of the Negro Prior to 1861*, Chs. VI and VII; and A. D. Adams, *The Neglected Period of Antislavery in America*, *passim*.

ment to abolish the slave trade, but for economic rather than for sentimental reasons. The prohibition of the slave **Slave trade** trade in Delaware, Maryland, Virginia and **in the South.** North Carolina did not necessarily show a humanitarian trend. The reasons for such action were largely economic. Their industry had reached a settled state, and the influx of more slaves, they believed, would lead to a decrease in the value of slaves, cause the supply of Southern products to exceed the demand, drain the States of money, and constitute a sinister influence on Negroes already broken in. If imported in large numbers the trade



TOUSSAINT L'OUVERTURE

might force upon the communities a larger number than could be supported, and instead of promoting slavery might make instant abolition necessary. Furthermore, the successful rebellion of the Negroes in Santo Domingo, led by Toussaint L'Ouverture and Desalines, brought such a dread of servile insurrection among the slaveholders that many of them opposed the continuation of the slave trade. And

even in the radically proslavery South, as in the case of South Carolina, it was specifically provided that no slaves should be imported from this disturbed area in the West Indies. As a matter of fact, however, many refugees from

Refugees Hayti had come to the ports of Baltimore, **from Hayti.** Norfolk, Charleston and New Orleans, and they sowed seeds of discord from which came most of the

uprisings of Negroes during the first three decades of the nineteenth century.²

The Congress of the Confederation had very little to do with slavery, as it did not care to interfere with the rights of the States. Slavery as a national question, however, appeared in the adoption of the Ordinance of 1787, providing for the organization of the Northwest Territory. The sixth clause of that document provided that neither slavery nor involuntary servitude, except for punishment of crime, should be permitted in the said territory. This was enacted, of course, prior to the adoption of the Constitution of the United States and may seem to have no bearing thereon, but as its legality was questioned on the ground that no such power had been granted to the Continental Congress by the States or by any provision in the Articles of Confederation, it requires special attention. It is of importance to note that it was defended on the untenable ground that it was a treaty made by the States forming the Confederation rather than an agreement of the States to be organized in this territory thereafter. The best which can be said for it, however, is that it was merely a legislative act of Congress.³

The convention of 1787 desired to take very little interest in the antislavery movement in the organization of the Federal Government. Oliver Ellsworth of Connecticut and Elbridge Gerry of Massachusetts thought the question of slavery should be settled by the States themselves. As this question came more prominently

**Slavery and
the Ordinance
of 1787.**

**The Conven-
tion of 1787.**

² These uprisings are set forth in Joshua Coffin's *An Account of the Principal Slave Insurrections*. See also Edwin V. Morgan's *Slavery in New York* (American Historical Association Report, 1895), pp. 629-673; and E. B. Greene's *Provincial America* (The American Nation), Vol. VI, p. 240.

³ All of these aspects of the Ordinance of 1787 are thoroughly discussed in J. P. Dunn's *Indiana; A Redemption from Slavery*, Ch. VI; and in Chas. Thomas Hickok's *The Negro in Ohio*, chapter on the Ordinance of 1787.

before this body called to frame the Constitution of the United States, however, it had to be considered more seriously, to determine a method of returning fugitive slaves, the prohibition of the slave trade, and the apportionment of

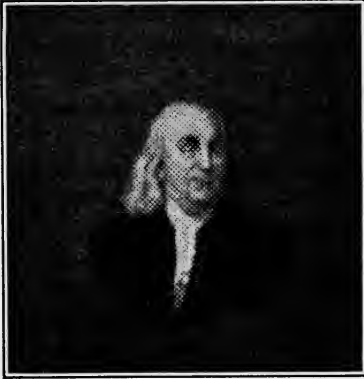

BENJAMIN FRANKLIN, an advocate of freedom

representation. When the South wanted the Negroes to be counted to secure larger representation on the population basis, although it did not want thus to count the blacks in apportioning federal taxes, some sharp debate ensued, but the northern antislavery delegates were not so much attached to the cause of universal freedom as to force their opinions on the proslavery group and thus

lose their support in organizing a more stable form of government.⁴ They finally compromised by providing for representation of the States by two Senators from each, and for the representation of the people in the House by counting all whites and five Negroes as three whites, and by further providing for the continuation of the slave trade until 1808, when it should be prohibited, and for a fugitive slave law to secure slaveholders in the possession of their peculiar property.

Immediately after the Federal Government was organized there seemed to be a tendency to ignore the claims of the Negro. In 1789 the Quakers at their annual meeting in

The Negro a negligible factor.

Philadelphia and New York adopted certain memorials praying the attention of Congress in adopting measures for the abolition of the

⁴ *The Journal of Negro History*, Vol. III, pp. 381-434.

slave trade and, in particular, in restraining vessels from being entered and cleared out for the purpose of that trade. There came also a memorial to the same effect from the Pennsylvania Society for the Abolition of Slavery, bearing the signature of its president, Benjamin Franklin. This led to much discussion of the slavery question, but the memorials were by a vote of 43 to 11 referred to a special committee which reported March 5, 1790. On the 8th the report was referred to the Committee of the Whole where it was debated a week. Several amendments were proposed and given consideration in the House. Finally the reports of the special committee and of the committee of the whole house were by a vote of 29 to 25 ordered to be printed in the Journal and to lie on the table. The principle of non-interference with slavery set forth in this report determined for a number of years the reactionary attitude of Congress with respect to slavery.⁵

⁵ The report of the Special Committee was: The committee to whom were referred sundry memorials from the People called Quakers; and also a memorial from the Pennsylvania Society for promoting the Abolition of Slavery, submit the following report:

That, from the nature of the matters contained in those memorials, they were induced to examine the powers vested in Congress, under the present Constitution, relating to the abolition of slavery, and are clearly of opinion,

First, That the General Government is expressly restrained from prohibiting the importation of such persons "as any of the States now existing shall think proper to admit, until the year one thousand eight hundred and eight."

Secondly, That Congress, by a fair construction of the Constitution are equally restrained from interfering in the emancipation of slaves, who already are, or who may, within the period mentioned be imported into, or born within any of the said States.

Thirdly, That Congress have no authority to interfere in the internal regulations of particular States, relative to the instruction of slaves in the principles of morality and religion; to their comfortable clothing; accommodations, and subsistence; to the regulation of their marriages, and the prevention of the violation of the rights thereof, or to the separation of children from their parents; to a comfortable provision in cases of sickness, age, or infirmity; or to the seizure, transportation, or sale of free negroes; but have the fullest confidence in the wisdom and humanity of the Legislatures

Congress refused also to intervene in behalf of certain manumitted Negroes of North Carolina, who after having been given their liberty by the Quakers were again reduced to slavery. The only action of this sort taken by Congress

**Non-inter-
vention by
Congress.** during its early operation was to pass the Fugitive Slave Law of 1793. This measure provided that a master might seize his absconding

slave taking refuge in another State, carry him before any magistrate and secure from that functionary authority to return the slave. Congress refused on this occasion to provide any safeguards to prevent the enslavement of free Negroes. No sympathy could then be expected from the North, for while that section considered the institution an evil, it had not in the least increased its love for the Negro, and evidences of unrest among Negroes did not make conditions more favorable. The North did not want the Negroes, and those southerners who had advocated their emancipation

of the several States, that they will revise their laws from time to time, when necessary, and promote the objects mentioned in the memorials, and every other measure that may tend to the happiness of slaves.

Fourthly, That, nevertheless, Congress have authority, if they shall think it necessary, to lay at any time a tax or duty, not exceeding ten dollars for each person of any description, the importation of whom shall be by any of the States admitted as aforesaid.

Fifthly, That Congress have authority to interdict, or (so far as it is or may be carried on by citizens of the United States, for supplying foreigners) to regulate the African trade, and to make provision for the humane treatment of Slaves, in all cases while on their passage to the United States, or to foreign ports, as far as it respects the citizens of the United States.

Sixthly, That Congress have also authority to prohibit foreigners from fitting out vessels, in any port of the United States, for transportation of persons from Africa to any foreign port.

Seventhly, That the memorialists be informed, that in all cases to which the authority of Congress extends, they will exercise it for the humane objects of the memorialists, so far as they can be promoted on the principles of justice, humanity, and good policy.

REPORT OF THE COMMITTEE OF THE WHOLE HOUSE

The Committee of the Whole House, to whom was committed the report of the committee on the memorials of the People called Quak-

were confronted with the question as to what should be done with them when freed.

The reaction in the North was generally manifested in the change of the attitude of the whites toward the blacks, who had during the struggle for the rights of man become connected with schools and churches throughout the section. It was therefore necessary for Negroes to establish independent churches of their own like those founded by Andrew Bryan in Georgia and Joseph Willis in Mississippi. Bearing it grievously that the people of color were suffering from a militant prejudice in the Methodist church, Richard Allen and James Varick established independent organizations out of which developed the African Methodist Episcopal Church and the African

**Reaction in
the Church.**

ers, and of the Pennsylvania Society for Promoting the Abolition of Slavery, report the following amendments:

Strike out the first clause, together with the recital thereto, and in lieu thereof insert, "That the migration or importation of such persons as any of the States now existing shall think proper to admit, cannot be prohibited by Congress, prior to the year one thousand eight hundred and eight."

Strike out the second and third clauses, and in lieu thereof insert, "That Congress have no authority to interfere in the emancipation of slaves, or in the treatment of them within any of the States; it remaining with the several States alone to provide any regulations therein, which humanity and true policy may require."

Strike out the fourth and fifth clauses, and in lieu thereof insert, "That Congress have authority to restrain the citizens of the United States from carrying on the African trade, for the purpose of supplying foreigners with slaves, and of providing by proper regulations for the humane treatment, during their passage, of slaves imported by the said citizens into the States admitting such importation."

Strike out the seventh clause.

Ordered, that the said report of the Committee of the Whole House do lie on the table.

See Text of both reports in the *House Journal*, 1st Cong., 2d Sess.; the report of the special committee is also in the *Annals of Congress*, 1st Cong., II, 1414, 1415, and in *Amer. State Papers, Miscellaneous*, I, 12. Full reports of discussions are in the *Annals*; condensed in Benton's *Abridgment*, I. See also von Holst's *United States*, I, 89-94; Parton's *Franklin*, II, 606-614; Wilson's *Rise and Fall of the Slave Power*, I, 61-67.

Methodist Episcopal Zion Church.⁶ In the same manner the opportunities for Negroes to acquire education became less frequent, as men tended to veer around to the exploitation conception of the Negro as a being desirable only so far as he answered some servile purpose of the white man. In education, however, the Negroes were too generally proscribed and they were economically too weak for independent action.

The treatment of the question of slavery in the purchase of Louisiana subsequently caused some debate when it was provided that in acquiring

**The
Louisiana
Purchase.**

the territory
of Louisiana
from France

the privileges and immunities enjoyed by those citizens under the government of the French would be guaranteed by the United States. This led to some future constitu-

tional questions, for the reason that since Louisiana was slaveholding prior to the purchase, the institution was thereby perpetuated in that territory. On the other hand, many of the Negroes of that territory belonged to the body of citizens exercising the same rights as the whites. When, a few years thereafter, Louisiana followed in the wake of the other reactionary States of the South and undertook to restrict the privileges of the free Negroes, it was contended that the action of the State conflicted with

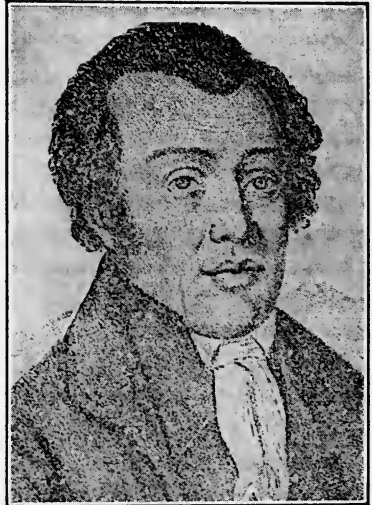

RICHARD ALLEN, the founder of the
A. M. E. Church

⁶ C. G. Woodson, *The Education of the Negro Prior to 1861*, p. 86.

this treaty guaranteeing those persons who were citizens at the time of the purchase the full enjoyment of the privileges which they had under the French régime. On the occasion of the enforcement of a law of that State depriving certain free Negroes of the right to attend school, this question was brought up in Mobile, Alabama, which at the time of the purchase belonged to the Louisiana territory. By special ordinance of the city council, however, these citizens were exempted from the operations of this law.

The great factors in bringing about the reaction, however, were primarily economic. During the second half of the nineteenth century, inventors, beginning with Watt, who built the first steam engine, brought out such mechanical appliances as the wool-combing machine, the spinning jenny, the powerloom, and finally Whitney's famous cotton gin. These revolutionized industries in the modern world, and in facilitating the making of cloth increased the demand for cotton, which led to the plantation system requiring the large increase in the importation of slaves. The cotton gin, a machine of revolving cylinders, one for tearing the lint from the seeds and another arranged to remove the lint from the first cylinder, simplified the process of seeding cotton, and in releasing labor for production multiplied its output in a few years. Cotton cloth was thereby cheapened and the demand for it so extensively increased that the South became a most inviting field in which was rooted one of the greatest industries of the world. Before the end of the second decade of the nineteenth century the States of the lower South became inalterably attached to slavery

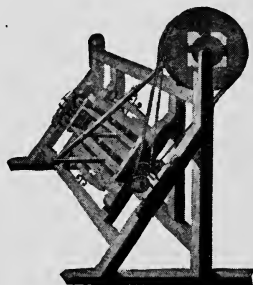

AN EARLY COTTON GIN

as an economic advantage in supplying the cheap labor it required and began to denounce those who persisted in dubbing it an evil.

With this increase in the demand for slaves there came numerous petitions for the reopening of the African slave trade in the lower South. The Northern and Middle States

Increase in the demand for slaves.

early prohibited the slave traffic, holding it as a grievance against George III that they were not permitted to do so earlier. Maryland prohibited it in 1783. North Carolina checked it by a rather high import duty in 1789, and South Carolina proscribed it by law for sixteen years. Georgia alone took no action except to provide for its own security in prohibiting the importation of insurrectionary slaves from the West Indies, the Bahamas and Florida, and to require free Negroes to furnish certificates of their industry and honesty.

An early effort was made to repeal the prohibitory provision against the traffic in South Carolina, but it was defeated. Those interested in the trade proceeded to smuggle slaves along the coast, and the efforts to enforce the prohibitory law were without success. Finally, in 1805, after much persistence, the slave-traders in that State carried their point, putting through the bill to remove all African restrictions but continuing the exclusion of Negroes from the West Indies and slaves from other States failing to have certificates of good character.

The action of South Carolina was interpreted as opening the door for all of the atrocities formerly practiced by the slave traders. North Carolina, New Hampshire, Vermont,

The Slave trade objectionable.

Maryland and Tennessee, therefore, requested their Congressmen to make an effort to have the Constitution of the United States so amended as to prohibit the importation of Negroes from Africa and the West Indies. Congress refused to act in this

case, not only because it had become reactionary, but for the reason that the time provided by the Constitution for the abolition of the slave trade would arrive in 1808. At the next session of Congress bills to prohibit the trade were introduced, but no action was taken.

In 1806 Jefferson took up the question in his annual message, urging Congress to interpose its authority to withdraw citizens of the United States from all further participation in those violations of human rights which had been "so long continued on the unoffending inhabitants of Africa."⁷ **Jefferson on abolition.** Senator Bradley of Vermont promptly introduced a bill with the provisions that interstate slave trade along the coast should be prohibited after the close of the year 1807 and that importation of slaves should be a felony punishable by death.⁸ In the House, where proslavery Congressmen managed the framing of the bill, it prohibited importation, provided fines and forfeiture of the slaves from abroad on board such vessels, and for the sale at public auction of slaves thus smuggled in. As it was evident that this bill would not prevent the enslavement of the blacks concerned, Mr. Sloan of New Jersey proposed to amend this bill so as to free the slaves thus forfeited. This proposition to turn loose in the South Negroes just from Africa evoked from Early, of Georgia, the prophecy of the prompt extermination of such Negroes in the Southern States. But speaking for his people, Smilie of Pennsylvania felt that he could not tolerate the idea of making the Federal Government a dealer in slaves. Such an act, thought he, would be unconstitutional. This provision was, after some excitement, stricken out.

An effort was then made to substitute imprisonment for

⁷ *Annals of Congress*, 1806-1807, p. 14.

⁸ The debate on the prohibition of the slave trade is treated in W. E. B. DuBois's *Suppression of the African Slave Trade*.

the death penalty, only to cause much more confusion. After more exciting discussion the House laid aside its bill for the one from the Senate, from which it promptly eliminated the death penalty and provided a penalty of imprisonment of not less than five nor more than ten years. The prohibition as to participation in coastal slave trade was eliminated also. The bill was then passed and sent back to the Senate. The Senate accepted this with the modification that the coastal trade provision be applied only to vessels of less than forty tons. There was still some opposition from Early of Georgia because he thought the bill in that form futile for the prevention of smuggling from Florida. John Randolph believed it interfered with a man's right of private property. The bill as passed penalized with imprisonment the importation of slaves from abroad, prohibited the slave trade along the coast in vessels of less than forty tons, required of larger vessels conformity to certain stipulated regulations, and placed smuggled slaves when seized at the disposal of the State where they might be landed.

This law, of course, was a victory for the lower South, then demanding an increase in the slave labor supply. With these evasive provisions favoring State control, the measure was never effective and the illicit trade flourished throughout the South without much interference. In fact, it was impossible to secure a conviction under this law until the Civil War, so effective had been public opinion in the South against the prohibition of the trade. This was the culmination of the reaction against the Negro in Congress. For economic reasons the South had pitted itself against the Constitution and, that Negroes might be further exploited by the whites, finally secured a majority sufficiently lacking in moral courage to evade carrying out the spirit of the fundamental law.

**Efforts in
behalf of
slave trade.**

**Victory for
the proslavery
group.**

The untoward condition of the Negro in the South resulted, too, from the unusually rapid spread of cotton culture and the extension of slavery in the uplands of the South, where it had been considered impracticable. The people of the frontier section, who had early constituted the opposition to the aristocratic pretensions of the slaveholders near the coast, gradually became indoctrinated in the tenets of the slaveholding aristocracy and began to develop the same thought as to politics

**Spread of
cotton culture.**



ANOTHER SORT OF SLAVERY

and religion as obtained near the coast. In the seaboard States, the interior of which lay among rugged hills or beyond seemingly insurmountable mountains, the hopes of democracy lingered longer because of the difficulty experienced in extending slavery beyond these barriers; but even these parts had to yield ground to the growing evil, despite

the warning given by statesmen in the prolonged debate resulting in the admission of Missouri as a slave State.⁹

In the same way the introduction of the culture of sugar in Louisiana accelerated the trade in that territory. By an additional act of Congress dealing with the prohibition of the slave trade in that State a loophole was left in the law so that it was construed to permit the importation of slaves from the other parts of the United States. Slave traders in some of the border States where the worn-out soil made the system unprofitable, moreover, supplied the Louisiana Territory in spite of restrictions to the contrary. They evaded the laws by purchasing slaves ostensibly for employment at home but only to be sold later in Louisiana after a brief stay to comply with the letter of the legal requirements. The result was an influx of speculators buying sugar land and bringing in slaves, until before the nineteenth century was far advanced the increasing number of estates reported and their large production placed the culture of sugar in the front rank of the industries of the South.

In this situation, then, the South soon reached the position that slavery is not an evil and by no means a sin, and that the only use to be made of a Negro is to impress him into the service of the white man. No care was taken of the blacks as of persons to be elevated, for they were to be beasts of burden. Negro women were often worked too hard to bear children, and it mattered not if they did not, since it was deemed less expensive to drive an imported slave to death during a few years and buy another in his place, than to undertake to increase his efficiency by methods of improvement. They were herded in pens like cattle, sold to do hard labor from the rising to the setting of the sun, given quarters in habi-

⁹ See the discourse of John Quincy Adams in the Appendix.

tations no better than the stables for animals, and fed upon the coarsest food known to be given to human beings. To prevent their escape, police control was effected by a patrol system which governed their going and coming so as to prevent them from assembling for help or from securing assistance or advice from sympathetic white friends and free Negroes.

CHAPTER VI

A DECLINING ANTISLAVERY MOVEMENT

AGAINST this system, which held in perpetual servitude millions of blacks, and prevented the elevation of the thousands of free persons of color to the dignity of citizenship, persons of sympathetic tendencies had for years persistently protested.¹ There was some antislavery sentiment from the very beginning of the introduction of slavery into the United States. Here and there in the colonies there were persons who seriously objected to the rigor to which the slaves were subjected in the development of the industries of the New World. These first protests, however, were largely on religious grounds, for the reason that the exploiting methods gave the Negroes no time for mental development or religious experience. Men who had at first accepted slavery as a means of bringing these heathen into a Christian land where they might undergo conversion to the faith, bore it grievously that selfish masters ignored the right of the Negroes to be enlightened.

Protests appeared more frequently during the eighteenth century, when religious freedom and liberty developed to the extent that the blacks were given some consideration. This antislavery sentiment, however, was not due primarily to cruel treatment of the slaves. In fact, the first Negro slaves were largely house servants, enjoying the treatment usually re-

**Effect on
the Negro's
status.**

¹ The early antislavery movement has been well treated in M. S. Locke's *Antislavery in America from the Introduction of the African Slaves to the Prohibition of the Slave Trade*, in Alice D. Adams's *Neglected Period of Antislavery in America*, and in the annual reports of *The American Convention of Abolition Societies*.

ceived among the ancient patriarchs. Some of them were servants indentured for a certain period, and even the slaves during the eighteenth century had many opportunities for obtaining freedom. The free Negroes had a social status of equality with that of the poor whites.

A bold attack on slavery, therefore, did not follow, as most of the objections raised during the eighteenth century were economic rather than sentimental, considering slavery prejudicial not only to the interests of the slaves themselves but to those of a country

**Mild attack
on slavery.**

desirous of economic betterment. As already observed, however, the struggle for the rights of man was productive of such a healthy sentiment in behalf of universal liberty that almost all of the fathers of the American Revolution favored a gradual extermination of the institution of slavery on the grounds that the Negroes had a natural right to be free. Antislavery societies were organized in the North and South immediately after the Revolution to secure to the slaves the fruits of the victory in behalf of the rights of man. To unify the efforts of these organiza-

**Abolition
societies.**

tions a national body, the American Convention of Abolition Societies, was formed to meet annually. A study of the records of these societies shows that the membership consisted largely of Quakers and such other enlightened persons of the more liberal connections as were disposed to attack the institution. These organizations were intended to mold public opinion in favor of the enslaved Africans with a view to exterminating slavery.

They did not contemplate instant abolition. The machinery for promoting the uplift of the Negroes, as further stated by them, had to do with methods of gradual emancipation. According to their scheme, they raised funds to purchase slaves, encouraged their emancipation, and provided for prospective freedmen opportunities for mental development and religious instruc-

**Gradual
emancipation.**

tion that they might properly function in society on becoming citizens. These bodies maintained, moreover, a sort of vocational guidance committee in each locality to look out for apprenticing Negroes to trades and to find employment for them in the various fields when they had developed into efficient mechanics.

The strongest influence against slavery which had hitherto developed, as already observed, came from the Quakers. After ridding themselves of slavery, they were, during the first decade of the nineteenth century, working strenuously to abolish the institution in other parts. They had, however, used passive means in reaching their ends, and for that reason had not gained very much ground; but they had done effective work in Virginia and North Carolina, and when they could not operate there as they desired they sent their slaves and others to the Northwest Territory where they had a new opportunity. It is doubtless due to their influence in North Carolina that a distinguished man like Judge William Gaston could call on the State to extirpate slavery. They, no doubt, had much to do with the fact that an appeal to abolish slavery in the North Carolina General Assembly failed only by the casting vote of the speaker, and that the institution was strongly attacked in the Virginia Convention in 1829-30, and in the legislature the following year.²

The inevitable effect of the reaction was sectionalism. As a more militant antislavery movement developed from the industrial revolution, which led to the extension of the plantation system, requiring more slaves, the South became gradually estranged from the North. The open violations of the act

**The results
of the
reaction.**

² C. G. Woodson, *Education of the Negro Prior to 1861*; S. B. Weeks, *Southern Quakers and Slavery*, and R. R. Wright, *Negro Rural Communities in The Southern Workman*, Vol. XXXVII, pp. 158-166.

prohibiting the African slave trade and the impetus given the domestic traffic to supply these plantations with Negroes, led to the bold attack on the institution during the first quarter of the nineteenth century. The cotton gin, although invented as early as 1793, had just then begun to do its work. During the first antislavery period there were no violent protests, as the workers concerned contented themselves with making an occasional speech or writing for a newspaper an article inveighing against the institution and setting forth plans for exterminating the evil. A considerable portion of the abolition literature which influenced public opinion appeared in the *Genius of Universal Emancipation*, published by Benjamin Lundy. Through this organ the sentiments of a large number of antislavery people living in the Appalachian highland found expression. They were descendants of the Germans and Scotch-Irish immigrants who came to this country to realize their ideals of religion and government, differing widely from those of the aristocratic planters who maintained a slavocracy near the coast. A few of these settlers of the uplands were gradually indoctrinated in the tenets of slavery in the proportion that the institution extended towards the mountains, but a large number of them continued even until the Civil War to work for the destruction of the institution. Out of this group developed a number of manumission societies in North Carolina, Tennessee and Kentucky. These organizations manifested the first radicalism the country had up to that time experienced.

Here we see the tendency not only to regard the institution of slavery as an economic evil but to consider it as a sin of which the Christian people should be ashamed. In 1810 Louis Duprey informed professing Christians that the great transgressions of slave commonwealths would lead to overwhelming judgments of God. Thinking of the evil of slavery, Thomas

Slavery an economic evil.

Jefferson, an uplander, said: "I tremble for my country when I reflect that God is just." David Barrow, of Kentucky, denounced in a pamphlet the inconsistency in the use of religious formulas in connection with the bequests of slaves, and advocated immediate emancipation. About the same time, John D. Paxton, a preacher in Kentucky and Virginia, believed in the "moral evil of slavery and the duty of Christians to aid slaves and free them." Daniel

Raymond of Maryland branded slavery as a "foul stain on our national escutcheon, a canker which is corroding the moral and political vitals of our country." Declaring slave traffic a curse to the master, John Randolph, of Virginia, said in Congress in 1816, "Do as you would be done by. Every man who leaves that great high road will have the chalice which he himself has poisoned—the chalice of justice, even-handed justice—put to his own lips

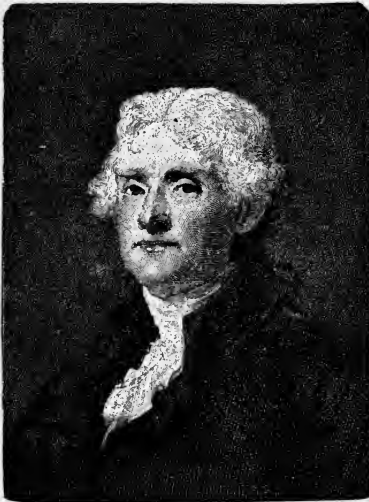

THOMAS JEFFERSON, an antislavery reformer

by the God of nature, who does not require abolition societies to carry his purpose into execution."

The spirit of antislavery, however, was declining in the South throughout the first half century of the republic.

Antislavery cause in the South. Free discussion of slavery was extended by the ardent debate over the Missouri question from 1819 to 1821. In this contest the proslavery and antislavery forces for the first time nationally

clashed. The question then was whether or not slave territory should be extended. By that time it was evident that the South was preparing to support the institution, whereas the North, in defense of free labor, had unconsciously become radically opposed to the extension of slavery. In so expressing itself in reply to the defense of the institution, the whole country became alarmed and the thinking public was impressed thereby with the idea that the country was then face to face with a problem requiring serious consideration. The United States had by this time developed a feeling of nationalism.

These protests, however, were scattered and they had little effect, for the abolition movement gradually became a sectional one. The antislavery societies which held wide sway until about the beginning of the nine-

The decline of the antislavery movement.

teenth century lost ground from year to year. The lower South early exterminated them, and, in the border States, where they had had extensive influence, they soon claimed only a few adherents. In 1827 there was one such society in Connecticut, none in Delaware, two in the District of Columbia, twelve in Illinois, eight in Kentucky, eleven in Maryland, two in Massachusetts, one in New York, fifty in North Carolina, four in Ohio, sixteen in Pennsylvania, one in Rhode Island, twenty-five in Tennessee, eight in Virginia. Less than a decade later almost all southern States in which most of these societies had developed ceased to support them, and the American Convention became largely a northern organization, and decidedly so, when it fell under the influence of the radicals.

As a sequel and a cause of the reaction came the bold attempts of the Negroes at insurrection.³ Unwilling to undergo the persecutions entailed by this change of slavery from a patriarchial to an economic system, a number of

³ For additional information as to the rising of slaves see Joshua Coffin's *Slave Insurrections*.

Negroes endeavored to secure relief by refreshing the tree of liberty with the blood of their oppressors. The chief source of these uprisings came from refugees brought to this country from Santo Domingo in 1793 and from certain free Negroes encouraged to extend

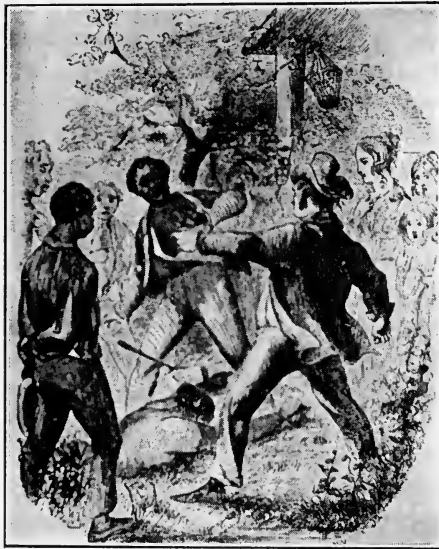

THE NEGRO CALLS A HALT

a helping hand to their enslaved brethren. The first effort of consequence was Gabriel's Insurrection in Virginia in the year 1800. It had been so deliberately planned that it was thought that white men were concerned with it, but an investigation, according to James Monroe, showed that there was no ground for such a conclusion. It was brought out, however, that these Negroes,

through channels of information, had taken over the revolutionary ideas of France and were beginning to use force to secure to themselves those privileges prized by the people in that country.

The insurrectionary movement was impeded but could not be easily stopped. At Camden in 1816, and some years later at Tarboro, Newberne and Hillsboro, North Carolina, there developed other such plots of less consequence. For some years these outbreaks were frequent around Baltimore, Norfolk, Petersburg and New

Orleans. In 1822, Charleston, South Carolina, however, was the scene of a better planned effort to effect the liberation of the slaves by organizing them to assassinate their masters. The leading spirit was one **Denmark Vesey**, an educated Negro of Santo Domingo, from which he had brought his new ideas as to freedom. It was observed that these Negroes in Charleston had been reading the slavery debate of the Missouri Compromise and were emboldened by the attacks on the institution to effect its extermination. In all of these cases the plans of the Negroes were detected in time to foil them, and the conspirators were promptly executed in such a barbarous way as to serve as a striking example of the fate awaiting those who refused to be deterred from such efforts.

An extensive scheme for an insurrection, however, came in 1828 from David Walker of Massachusetts, who, in a systematic address to the slaves throughout the country, appealed to them to rise against their masters. Walker said: "For although the destruction of the oppressors God may not effect by the oppressed, yet the Lord our God will bring other destruction upon them, for not unfrequently will he cause them to rise up one against the other, to be split, divided, and to oppress each other, and sometimes to open hostilities with sword in hand."⁴

But the most exciting of all of these disturbances did not come until 1831, when Nat Turner, a Negro insurgent of Southampton County, Virginia, feeling that he was ordained of God to liberate his people, organized a number of daring blacks and proceeded from plantation to plantation murdering their masters. Having obtained great influence over the minds of his followers, he was in a position to interest a much larger

Denmark Vesey.

David Walker's Appeal.

Nat Turner's Insurrection.

⁴ David Walker's *Appeal*, p. 5.

number of them than other Negroes who had undertaken to incite their fellows to self-assertion. With the aid of six desperate companions, who finally increased tenfold, he killed sixty whites. After a few days of slaughter and local warfare, Turner and his followers were finally driven into the swamps by the State militia and United States troops. On the first day over a hundred Negroes were killed. After

a few days of resistance they were overpowered and imprisoned. Twelve Negroes were promptly convicted and expatriated, but Nat Turner and twenty of his accomplices were hanged. An effort was made to connect William Lloyd Garrison and David Walker with this rising, but no evidence to this effect could be found. Garrison disclaimed any connection with the insurrection. The thought then that slaves themselves could cause such a disturbance



NAT TURNER

struck terror to the very heart of the South, which thereafter lived in eternal dread of servile insurrection.

This was sufficient to convince the South that if economic slavery was to be successful, the one thing needful was to close up the avenues of information to the Negroes. The

**Stringent
measures in
the South.**

first effort in this direction was to extend the slave code so as to penalize a number of deeds which theretofore had not been punishable by law. The Southern States enacted more stringent measures to regulate traveling and the assembling of slaves,

to make them ineffective in assembling for insurrection purposes or for information from contact with other persons or from schools. These stringent measures applying to traveling and assembly were not restricted to slaves but made applicable also to the free Negroes and mulattoes. The wording of these laws differed to a certain extent, but they usually provided that it would be unlawful for Negroes or slaves above a certain number, usually five, to assemble without the permission of their masters, even for worship, unless the services were conducted by a recognized white minister or observed by "certain discreet and reputable persons." Some States prohibited the immigration of free persons of color, and because of the circulation of bills, literature, and such inflammatory pamphlets as that of David Walker, there were enacted several laws to the effect that whosoever should write, print, publish or distribute such literature so as to spread discontent among the slaves would be imprisoned for life or put to death. It was still further provided that all persons who should teach or cause to be taught any slave to read or write should suffer the same penalty.

In many of the Southern States, however, the effort was made not only to regulate the traveling and assembling of the free Negroes but to get rid of them entirely by giving them so many days to leave the State.⁵ The **Free Negroes** Missouri General Assembly enacted in 1819 a **driven out.** law providing that there should be no more assemblages of slaves or free Negroes or mulattoes, mixing or associating with such slaves for teaching them to read, and when that State framed its constitution on being admitted into the Union it incorporated into that document a provision to prevent the immigration of free Negroes into that State. Louisiana prohibited the immigration of free persons of

⁵ See C. G. Woodson's *A Century of Negro Migration*, p. 40; and *The Education of the Negro Prior to 1861*, pp. 151-178.

color in 1814, and in 1830 excluded such persons from the State, giving them a definite period to leave.

In 1831 Mississippi followed in the footsteps of her sister State. In cases where free Negroes were not driven out, as in South Carolina, certain stringent measures to safeguard the interests of the slaveholders materially in-

terfered with the economic welfare of these persons of color. In 1834, when South Carolina provided that there should be no teaching of Negroes by white or colored friends and that their schools should be disestablished, it provided also that persons of African blood should not be employed as clerks or salesmen in or about any store or house used for trading. This legislation did not disgrace the statute books of the border States of Kentucky, Maryland and Tennessee, but public



THE MOTHER AND CHILD

opinion there sometimes had the same effect.

Against this system of repression, however, a few prominent men of the South continued to protest. Chancellor Harper of South Carolina felt that it was shameful to

Protests of sympathetic southerners.

prevent the blacks from obtaining sufficient knowledge to read the Bible. Daniel R. Goodloe, of North Carolina, was of the same opin-

ion. Southerners of the most radical type, moreover, did not like to live under the stigma with which they were branded by William Jay, who charged them with having closed up

the Bible in denying the Negroes the revelation of God, while at the same time they styled themselves Christians. Some opposition was, therefore, shown, and in certain parts it was found impossible to execute restrictive measures because of the healthy public opinion against them. The children of the sympathetic aristocratic slaveholders, and especially the wives and children of ministers, hardly ceased to teach Negroes to read as much as the Bible. Under the direction of Bishop Capers of South Carolina, Reverend Josiah Law and Reverend C. C. Jones of Georgia, and Bishop Polk of Louisiana, much was accomplished by a new system of training called religious instruction. Under this system the Negroes were not allowed to read and write but were taught to commit to memory in catechetical form the principles of religion and instructive parts of the Bible.⁶

This reaction, however, was not peculiar to the slave States.⁷ In the proportion that free Negroes, finding it impossible to live in the South, sought refuge in the North, race prejudice and friction increased. These culminated in race riots, easily developed in

**Reaction in
the North.**

that section at the time the country was receiving a number of Irish and German immigrants who competed directly with the Negroes as laborers. Negroes were not permitted to enter the academy thrown open to them at Canaan, New Hampshire, in 1834; the people of New Haven at a public meeting of their leading citizens strenuously protested against establishing there a manual labor school for the education of Negroes; and the citizens of Canterbury actually imprisoned Prudence Crandall by securing special legislation to that effect because she persisted in admitting Negro girls to her seminary, which in becoming attractive

⁶ See also C. G. Woodson's *A Century of Negro Migration*, pp. 39-60.

⁷ This is extensively treated in C. C. Jones's *Religious Instruction of Negroes* and in C. G. Woodson's *Education of the Negro Prior to 1861*, Ch. VIII.

to that race might increase the colored population of that city to the displeasure of its white citizens.

Riots of a graver sort were frequent throughout the North during these years. The first sanguinary conflicts of consequence took place in Ohio. In 1826 a mob under-
Race riots in took to drive the Negroes out of Cincinnati.
the North. In 1836 another mob not only attacked Negroes but broke up also the abolition press, which was supposed to encourage the influx of persons of that class. In 1841 there was in the same city a local race war which for a week disturbed that metropolis to the extent of resulting in the death of a number of persons and the expulsion of many Negroes from the city. On a "Black Friday," January 1, 1830, eighty of the two hundred Negroes living in Portsmouth, Ohio, were driven out of the city as undesirables. A mob of Germans drove John Randolph's Negroes from their own land in Mercer County, Ohio, where he had provided for their settlement and freedom.

The East offered no exception to this rule. The citizens of Philadelphia began to burn Negro homes in 1820, sought to expel the blacks from the city and State in 1830 and
Riots in actually mobbed them in 1834, destroying
the East. their churches and other property. In 1838 another conflict developed into a riot which resulted in the destruction of Pennsylvania Hall and the Colored Orphan Asylum in that city. When the Negroes in 1842 undertook to celebrate the abolition of slavery in the West Indies, another occasion was afforded for race conflict, which meant a loss of life and property to the Negroes. Pittsburg, following the example of Philadelphia, had such a riot in 1839. In 1834, this rule of the mob in New York City and Palmyra led to riots during which the Negroes were attacked along the streets and driven from their homes.

CHAPTER VII

ECONOMIC SLAVERY

THE plantation system resulting from the industrial revolution, the cause of the radical reaction, made slaveholding a business of apparently tremendous possibilities. Large sums were invested in the enterprise, and the South entered upon its career as a borrowing section. There was a rush of southern white men from the older States along the coast to the fertile cotton lands of the Gulf district as soon as they were opened for settlement. Many came almost empty handed, but the majority of those taking up large tracts of land brought their slaves with them. The number of slaves increased forty or fifty per cent between 1810 and 1820, and they came thereafter in droves.¹

On their way to the Southwest the slaves experienced the usual hardships of a long drive. The inhuman traders placed the children in wagons and forced the men and women to walk from twenty-five to fifty miles a day. Often traders encountered on the way bought some of the slaves in transit, after subjecting them to such an examination of their teeth and other parts as to determine their age and health. Featherstonaugh mentions his meeting in southwestern Virginia a camp of

¹ A. B. Hart, *Slavery and Abolition*, Chs. IV, V, VI, and VII; U. B. Phillips, *American Negro Slavery*, pp. 151-401; W. E. B. DuBois, *The Negro*, Ch. IX; M. B. Hammond, *The Cotton Industry; Debow's Review*; Williams Wells Brown, *The Rising Son*, 265-318; G. W. Williams, *History of the Negro Race in America*, Vol. I, pp. 115-324; and J. B. McMaster's *History of the United States*, VII, pp. 238-370.

Negro slave drivers just packing up to start. He said: "They had with them about three hundred slaves who had bivouacked the preceding night in chains in the woods. These they were conducting to Natchez, on the Mississippi River, to work upon the sugar plantations in Louisiana. It resembled one of the coffles spoken of by Mingo Park, except that they had a caravan of nine wagons and single-horse carriages for the purpose of conducting the white people and any of the blacks that should fall lame. The female slaves, some of them sitting on logs of wood while others were standing, and a great many little black children, were warming themselves at the fire of the bivouac. In front of them all, and prepared for the march, stood in double files about two hundred men slaves, manacled and chained to each other."²

Referring to one of these parties, Basil Hall said: "In the rear of all came a light-covered vehicle with the master and mistress of the party. Along the roadside scattered at intervals we observed the male slaves trudging in front. At the top of all, against the sky line, two men walked together apparently hand in hand, pacing along very sociably. There was something, however, in their attitude which seemed unusual and constrained. When we came nearer accordingly, we discovered that this couple were bolted together by a short chain riveted to broad iron clasps secured in like manner round the wrists."³

Josiah Henson, a Negro brought into this traffic, said: "Men trudged on foot, the children were put into the wagon, and now and then my wife rode for a while. We went through Alexandria, Culpepper, Fauquier, Harper's Ferry, Cumberland, and over the mountains to the Natural Turnpike to Wheeling. In

² G. W. Featherstonaugh, *Excursion through the Slave States*, Ch. I, p. 120.

³ Basil Hall, *Travels in North America*, Ch. III, pp. 128-129.

all the taverns along the road were regular places for the droves of Negroes continually passing along under the system of internal slave trade. At the places where we stopped for the night, we often met Negro drivers with their droves, who were almost uniformly kept chained to prevent them from running away. I was often invited to pass the evening with them in the bar-room—their Negroes,

in the meantime, lying chained in the pen, while mine were scattered around at liberty.”⁴

Edwin L. Godkin said: “The hardships these Negroes go through who are attached to one of these migrant parties baffles description. They trudge on foot all day through mud

Hardships.

and thicket without rest or respite. Thousands of miles are traversed by these weary wayfarers without their knowing or caring why, urged on by whip and



JOSIAH HENSON, prototype of
Uncle Tom's Cabin

in full assurance that no change of place can bring any change to them. Hard work, coarse food, merciless flogging, are all that await them, and all that they can look to. I have never passed them staggering along in the rear of the wagons at the close of a long day's march, the weakest furthest in the rear, the strongest already utterly spent, without wondering how Christendom, which eight centuries ago rose in arms for a sentiment, can look so

⁴ Josiah Henson, *Uncle Tom's Story of His Life*, p. 53.

calmly on at so foul and monstrous a wrong as this American slavery." ⁵

This migration, of course, had a disastrous effect on the seaboard States from which so many masters and their slaves were drawn. Industry was paralyzed on the lower Atlantic coast. There were the worn-out lands with deserted homes once characterized by abundance and luxury, ruined and distressed debtors wondering how to find relief, humiliated planters with no way of escape but migration. Efforts at fertilization to rebuild the waste places were tried, and with this the slave States near the Atlantic experienced a sort of revival about the middle of the nineteenth century. This was due also, some think, to the demand for slaves as laborers on the railroads which were then being constructed to unite the South and to connect it with the West.

To supply the Southwest with slaves, however, the domestic slave trade became an important business, and the older States which suffered from the migration devoted themselves to slave breeding for this market. In the work entitled *Slavery and the Internal Slave Trade in the South*, it is estimated that seven of the older States annually exported 80,000 to the South. These were Virginia, Maryland, North Carolina, Kentucky, Tennessee, Missouri and Delaware. Professor Asa Martin thinks that Kentucky furnished 5,000 a year. This flourished the more because of the restrictions on the African slave trade. One writer estimates the number of slaves exported from Virginia at 120,000. It is difficult to figure out numbers, however, for the documents bearing on the sale of slaves did not always determine exactly what their destination would be. Men sometimes bought them apparently for private use, concealing their ultimate aim to sell

⁵ *The North American Review*, Vol. CLXXXX, pp. 46, 47.

them South. Except when forced by economic necessity or in the case of insubordination, some masters refused to sell their slaves if they knew that they would have to undergo the tortures of servitude in the cotton and sugar districts. It is also difficult to determine who were the interstate slave traders. Almost all commission merchants dealt in slaves as in any other property, and they were not anxious to be known as being primarily interested in a



A SLAVE AUCTION

work which was in no sense popular among the more nearly civilized slaveholders.

Some of these masters, in advertising slaves for sale, specifically stated that they were not to be sold out of the State, and persons who were bold enough to proclaim themselves as such traders were mentioned with **Slaves sold south.** opprobrium in the older slave States.⁶ The presence of such traders in Winchester, Virginia, in 1818,

⁶ I. E. McDouglass, *Slavery in Kentucky* in *The Journal of Negro History*, Vol. II, pp. 226-230.

evoked the comment: "Several wretches, whose hearts must be as black as the skins of the unfortunate beings who constitute their inhuman traffic, have for several days been impudently prowling about the streets of this place with labels on their hats exhibiting in conspicuous characters the words, 'Cash for Negroes.' " Some time in the thirties of the last century a master of Danville, Kentucky, sold a Negro woman to a regular slave trader. Upon learning this, threats of a mob to do him violence compelled this master to go in quest of the trader, from whom he repurchased the woman at a decidedly increased price.⁷ Yet, intense as this feeling was, Delaware was the only slave State to legislate against the interstate slave trade. Maryland, Kentucky and Louisiana undertook somewhat to regulate it.

This enlightened minority could not stop this traffic, and it became for a number of centers in the border States a source of much revenue. Dealers bought up slaves in the local markets and confined them in jails, taverns, warehouses or slave pens, while awaiting buyers from the Southwest. The average slave pen had an administration building for the slaves, a court for the women and one for the men, with gates, barracks, and eating sheds. Some of the slave pens, however, were no more than stables for cattle or horses. On the convenient day they were placed on the sales block and auctioned off to the highest bidder. The slaves themselves, sometimes for personal advantage in determining their buyers, aided or impeded the sale by singing their own praises or proclaiming their shortcomings. Thus they spent weeks and months until the owner drove a bargain with a trader, who removed them in coffles to their doom in the rising cotton kingdom.

⁷ *The Journal of Negro History*, Vol. III, p. 229.

In this way the Negroes were made the means of exploiting the new Southwest by accelerating the westward movement from the South. The slaves were thereby taken from a declining section, where they had become such a burden that these States would have necessarily become antislavery, had they remained. These blacks were carried to the cotton district, where they were apparently profitable servants in developing a new industry. The 85,000,000 pounds of cotton produced in 1810 doubled by 1820, doubled again during the next decade, and doubled still once more by 1840. This was then about two-thirds of the cotton production in the world. After that period there was no question as to our leadership in the production of this raw material.

What, then, was the plantation system, serving as the basis of this large cotton industry? This was the method of cultivating an estate of hundreds and sometimes thousands of acres. The administration centered **The** in the residence of the planter or, in case of **plantation.** absentee ownership, in the home of the manager of the estate. Nearby stood the stable, smoke house, corn house, and a little farther away appeared the garden, potato field, watermelon patch, and the like. Somewhat distant from this central building were the homes of the slaves, commonly known as quarters. These were in most cases rude huts, often with dirt floors and so poorly constructed as to furnish little protection from bad weather. Furniture was generally lacking unless the few stools and the beds of straw be worthy of such designation. In some cases the slaves were allowed to till a patch of ground on which they produced their own vegetables, and some few of them were permitted to raise chickens or hogs. They had to look after these personal affairs at night, on Sundays, or holidays, as their whole time was otherwise required in the service of their masters.

In the case of just a few slaves the master often worked with them. On larger plantations, however, slaves worked in gangs under masters or their overseers, if the master had **Slaves at** sufficient holdings to afford such supervision. **work.** In the culture of rice the work could be so divided as to assign it as tasks, holding each slave responsible for a definite accomplishment. Some few planters, like McDonogh of Louisiana, and Z. Kingsley of Florida, ran

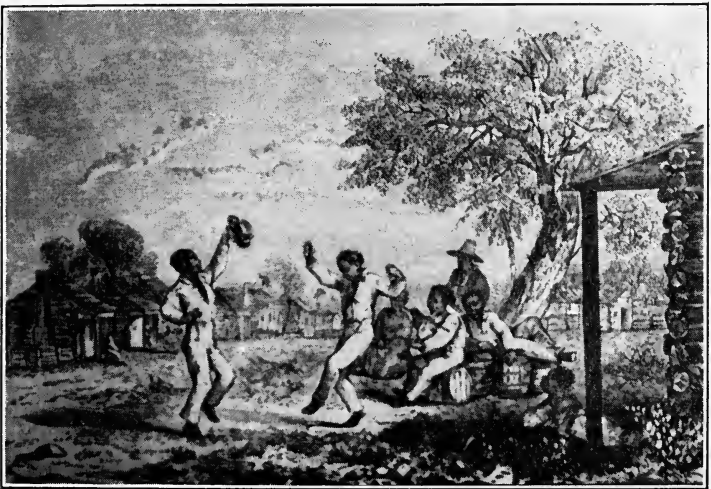

A PLANTATION

their plantations on something like the self-government basis. Slaves were thrown largely on their own initiative to earn what they could. The control was vested in courts, the personnel of which were slaves, and the administrative officers of which were also bondmen carrying out the mandates of these tribunals. Isaiah T. Montgomery of Mound Bayou, Mississippi, was taught with white children and trained as an accountant to serve in this capacity on the Joseph Davis plantation in Mississippi.

As a plantation was a community in itself, it had to be governed as such. On large plantations managed by men of foresight, definite rules were drawn up to determine the procedure of overseers and slaves. These were intended to maintain the government of the slaves, produce the largest crop possible, and at the same time to exercise such care over the bondmen as not to lose any of them by unnecessary harsh treatment and neglect of their health. On some plantations, however, masters either worked to their own detriment by driving their slaves to an untimely death, or by the absentee ownership procedure, permitted their overseers to do so. This was often true in cases in which overseers were paid by giving them a share of the crop. The abuses practiced by these managers caused many planters to brand them as being a negligent, selfish, and dishonest class. The situation was not any better when the slaves were placed under a Negro driver.

Slaves were not generally cared for when sick. Women in pregnancy were more neglected than ever, and some worked too hard to bear healthy children. Many slaves were not given sufficient of the simple corn-bread, bacon and salt herrings they were allowed, and a still larger number were not adequately clothed. Negroes supplemented their rations by hunting and trapping at night. Some of them, by working at night, accumulated means by which they added to the meager provisions for their families supplied by their masters. A few hoarded considerable sums with which they purchased their freedom and made their way to free States where they established themselves anew. Others had to steal to obtain a subsistence, and were even encouraged to do so by parsimonious masters.

Above all, punishments were crude and abusive. Because it would be prejudicial to their own economic interests, masters no longer mutilated Negroes or destroyed them

**Plantation
management.**

**The care
of slaves.**

on the wheel, as in the eighteenth century, unless it was absolutely necessary; but flogging, unmerciful beating and even burning at the stake sometimes followed. In cases of unruly Negroes they were sold South, where **Punishments.** they faced the alternative of either yielding or being punished to death. The runaway slaves were hunted with dogs. When brought back they were put in heavy iron shackles or collars and sometimes subjected to such tortures as drawing out the toe-nails. Those persisting in resisting their masters were sometimes murdered. These conditions, however, differed from plantation to plantation, according to the liberality of the master.

The slave, after the reaction, was not generally allowed any chance for mental development, of course, and could not learn to appreciate religion. Planters in some parts, **Enlightenment** thinking that the teaching of religion might **prohibited.** lead to the teaching of letters, prohibited it entirely. The best slaves could then do for mental development was to learn by contact and by stealth. Many a sympathetic person taught slaves to read, and in some cases private teachers were bold enough to maintain schools for them, as was done in Savannah, Charleston, and Norfolk.

How some of these slaves learned in spite of opposition makes a beautiful story. Knowing the value of learning as a means of escape and having a longing for it, too, because it was forbidden, many slaves continued **Stealing** **learning.** their education under adverse circumstances. Some of them, like Frederick Douglass, had the assistance of sympathetic whites who were a law unto themselves; others studied privately and even attended school. Children of the clergy, accustomed to teach slaves to read the Bible, were, by custom, regarded as enjoying an immunity. Some private teachers among the whites encouraged Negroes to steal away to secret places where their operations were shielded from the zealous execution of the law.

The majority of these enlightened slaves, however, learned by contact, observation and dint of energy.⁸ Many of them were employed at such occupations as to develop sufficient mental power to read, write, and cipher. **Learning by contact.** "Blazon it to the shame of the South," said

Redpath, "the knowledge thus acquired has been snatched from the spare records of leisure in spite of their honest wishes and watchfulness." Many, like Robert Williams and Albert T. Jones, stole enough to enable them to read with ease. Lott Cary heard a minister preach from the third chapter of St. John, and on returning home read that passage of scripture, although he had never before been taught to read and had not hitherto made such an effort. Dr. Alexander T. Augusta of Virginia learned to read while serving white men as a barber. President Scarborough of Wilberforce was taught by one J. C. Thomas, a cruel southerner of the bitterest type.

In spite of their circumstances a few slaves experienced another sort of mental development. Being in a rapidly growing country where the pioneers had to make use of the forces of nature, here and there a slave became **Inventions of slaves.** an inventor. According to the opinion of Henry E. Baker, an examiner in the United States Patent Office, slaves made certain appliances, experimenting with the separation of the seed from cotton, which, when observed by Eli Whitney, were assembled by him as the cotton gin. Freedmen, during these years, were more successful. While James Forten, a free Negro of Philadelphia, was making a fortune out of his new device which he perfected for handling sails, Henry Blair, of Maryland, interested in labor saving, patented two corn harvesters in 1834 and in 1836. Norbert Rillieux, a man of color in Louisiana, patented an evaporating pan by which the refining of sugar

⁸ C. G. Woodson, *Education of the Negro Prior to 1861*, Ch. IX.

The Negro In Our History

M. Rillieux

Evaporating Pan,

N^o 4,879

Patented Dec. 10, 1846

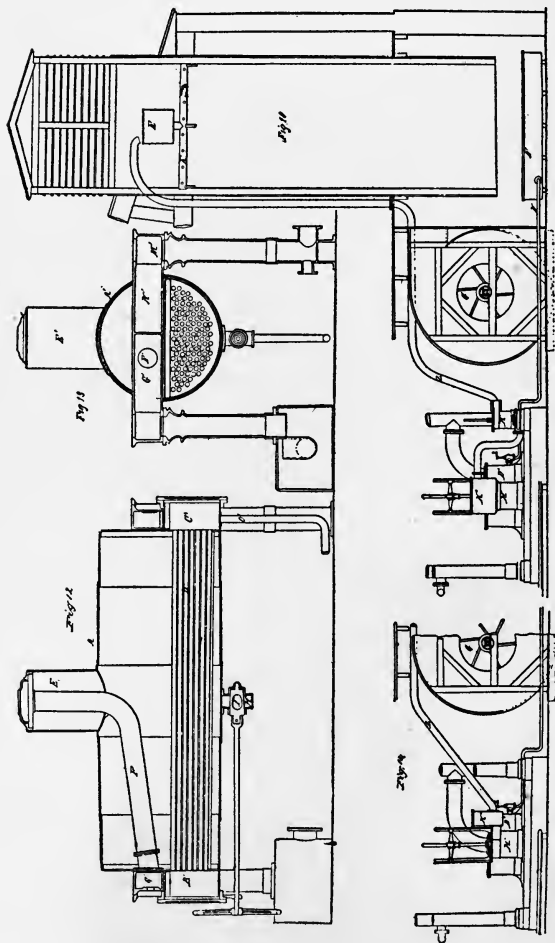

was revolutionized. There is much evidence that some of the inventions brought out by white persons in the South prior to the Civil War were devices invented by Negroes. The slave as such, according to an opinion of Jeremiah S. Black, attorney-general of the United States in 1858, could not be granted a patent, for the reason that the slave could neither contract with the government nor assign his invention to his master. Confronting this problem, when Benjamin T. Montgomery, a slave of Jefferson Davis, was on this ground denied a patent on an invention, the President of the Confederate States secured the enactment of the law providing for patenting inventions of slaves.⁹

In spite of these notable exceptions under this economic system, however, the Negro race became an element with which the whites would not deal as man with man. The whites were by law and public opinion re-
**Negroes
socially
proscribed.**
 strained from accepting Negroes as their social equals, and miscegenation of Negro men and white women was penalized as a high crime, although there were always a few instances of such association. Abdy, who toured the country from 1833 to 1834, doubted that such laws were enforced. "A Negro man," said he, "was hanged not long ago for this crime at New Orleans. The partner of his guilt—his master's daughter—endeavored to save his life, by avowing that she alone was to blame. She died shortly after his execution."

With the white man and the Negro woman, however, the situation was different. A sister of President Madison once said to the Reverend George Bourne, then a Presbyterian

⁹ This law was:

And be it further enacted, That in case the original inventor or discoverer of the art, machine or improvement for which a patent is solicited is a slave, the master of such slave may take oath that the said slave was the original; and on complying with the requisites of the law shall receive a patent for said discovery or invention, and have all the rights to which a patentee is entitled by law.

minister in Virginia: "We Southern ladies are complimented with the name of wives; but we are only the mistresses of seraglios."¹⁰ But the masters of the female slaves were not the only persons of such loose morals. Many women of color were prostituted also to the purposes of young white men and overseers. Goodell reports a well-authenticated account of a respectable "Christian" lady at the South, who kept a handsome mulatto female for the use of her genteel son, as a method of deterring him, as she said, "from indiscriminate and vulgar indulgences." Harriet Martineau discovered a young white man who on visiting a southern lady became insanely enamored of her intelligent quadroon maid. He sought to purchase her, but the owner refused to sell the slave because of her unusual worth. The young man persisted in trying to effect this purchase and finally informed her owner that he could not live without this attractive slave. Thereupon the white lady sold the woman of color to satisfy the lust of her friend.

Against the hardships of the system numerous slaves rebelled. Most of them did nothing to injure their masters, so thoroughly had they become intimidated after Nat Turner's fate, but they endeavored to make their escape into the woods, too often only to be brought back after a few weeks' adventure. The newspapers quickly proclaimed the news of a runaway, offering in its advertisements some attractive reward. White men assisted with firearms, and bloodhounds trained to run down fugitives, hunted them like game even in the North. That section, struck by the inhuman methods to recapture slaves, passed personal liberty laws to prevent the return of the Negroes apprehended, as many of these were kidnapped

¹⁰ *The Journal of Negro History*, Vol. III, p. 350.

free persons taken under pretext of being runaways.¹¹ These laws, however, were nullified by the decisions of the federal courts and the Fugitive Slave Law of 1850, which undertook to impress into the service of slave-hunting men who were conscientiously opposed to the institution. The North was then the scene of the most disgraceful deeds,



THE PURSUIT

which aroused the consciences of the people and swelled the ranks of the abolition minority which at one time seemed to decline to meet premature death.

The efforts of the slaves to escape from bondage, however, were unusually successful in the Appalachian mountains, where there had been retained a healthy sentiment against slavery. The mountaineers of North **Fugitives.** Carolina, Kentucky and Tennessee organized antislavery

¹¹ These Laws are collected in Hurd's *Law of Freedom and Bondage*.

societies during the first quarter of the nineteenth century. When that movement became unpopular they generally supported the cause of colonization, which served as the best solution of the immediate problem of the race; for the frontiersmen were not particularly attached to the Negro race but felt that the institution of slavery was an economic evil of which the country should rid itself by a system of gradual emancipation as soon as possible. When, however, the conditions of the Negroes in the South became so intolerable that it was necessary to flee for larger liberty in the Northern States, they found it easy to make their way through this region where the farmers were not attached to the institution. It was of some help, too, that they could easily hide in the mountains and in the limestone regions which furnished comfortable caves. The promoters of the Underground Railroad, therefore, offered them a way of escape by extending their system southward through the mountains of these States so as to connect with the fugitives escaping thither. These lines led through Kentucky into Ohio, Indiana and Illinois, and connected with the Great Lakes, over which the fugitives passed into Canada, under the guidance of persons like the heroic Josiah Henson, Harriett Tubman, and John Brown.¹²

Slaves in urban communities enjoyed more privileges. Employed in the trades and domestic service affording close contact with their masters, they were economically better off than the free Negroes whom they often doomed to poverty by crowding them out of the various pursuits of labor. There was scarcely any industry in which slaves did not engage, and in most cases to the exclusion or at the expense of the poor whites as well as of the free blacks. Some contractors owned their workmen

¹² W. H. Siebert, *Underground Railroad*, p. 166.

just as masters owned the Negroes on their plantations. Master mechanics less favorably circumstanced hired slaves. In a few cases slaves were employed under the direction of a slave master mechanic who took contracts, managed the business, and reported to the master at certain periods. It was soon learned, however, that a slave as such easily competed with free Negroes and whites. It was, therefore, necessary for the masters to grant such bondmen the larger freedom of profit-sharing or of hiring themselves to stimulate them to greater endeavor. This custom proved prejudicial to white mechanics, and in several States laws were passed to prevent the hiring of slaves to themselves. But this custom continued in spite of strenuous efforts to the contrary, as the enforcement of it would have materially restricted the use of slaves. Many slaves thus employed were cheated



HARRIETT TUBMAN

in the end by dishonest contractors, but others more fortunately situated contrived thereby to purchase their own freedom and that of their families. To do this many Negroes worked at night after finishing their tasks by day, but this privilege served as another reason for legislation against this custom, as it would lead to an increase in the number of free Negroes who might promote servile insurrection.

In the city, too, it was possible for the Negroes to main-

tain among themselves certain social distinctions based upon their advantages of contact with the whites and the amount of culture they had taken over. Those employed **Social distinctions.** in the higher pursuits of labor and as domestic servants to the rich whites were enabled by the working-over of cast-off clothes and imitating their masters' language and airs, to lord it over the crude slaves of the fields. In culture the less fortunate Negroes were further separated from these urban free blacks than the latter were from the whites. In their social affairs they sometimes had much liberty and apparently experienced much joy. They so impressed travelers with their contentment in this situation that some concluded that the Negroes had no serious objection to their enslavement.

Slavery as an economic system, however, required more restriction in religious matters, especially after the Southampton insurrection. Northern Negroes undertook to extend the work of their independent connections into the **Restrictions on religious affairs.** South, as in the case of Charleston, South Carolina, to which the African Methodists, after their withdrawal from the whites, summoned Negroes to be ordained to serve in that city. This freedom of action, however, was too much for the South, and the independent church movement there was stopped. Meetings were prohibited and the bishop, his exhorters, and immediate followers were ordered to be imprisoned if they did not depart from the State, while others were fined or given a number of lashes. As Negroes were thereafter forced to accept what accommodations were given them in the white churches, they gradually yielded room to the increasing membership of the whites until the blacks were forced to the galleries or compelled to hold special services following those of the whites. A refusal of Negroes to give up to the whites prominent seats long occupied by them in a church in Charleston, South Carolina, led to their ejection

by a group of white youths. When criticized for this these young members behaved so unbecomingly that nine of them had to be expelled; but to show their attachment to the southern policy one hundred and fifty others left with them.

Unsuccessful efforts were then made to establish separate churches for the slaves, like the Calvary Church in Charleston, and the African Baptist Church in Richmond. For feigned reasons the legal endorsement for the latter was not given until 1855, and then **Negro churches.** on the condition that a white minister be employed. In the churches in the cities in the border States, however, there was more religious freedom among the slaves. There was a Baptist Church in Lexington, Kentucky, in 1830. George Bentley, a Negro preacher of polemic distinction, was preaching to the most enlightened whites as well as blacks in Giles County, Tennessee, in 1859; and Henry Evans, a shoemaker and licensed Methodist minister, preached with such success for the conversion of the sinful in Fayetteville, North Carolina, that from his efforts there was organized a church with a membership drawn from both races. The white members became so numerous that they crowded out the Negroes. In the large cities there was still more religious freedom. Washington Negroes had several churches early in the nineteenth century, and Baltimore had ten churches for slave and free Negroes in 1834.

The South, however, had succeeded in hedging in the Negro so that he might forever afterward do the will of his master, but this seemingly sane method of developing the South was what resulted in its undoing. **Slavery, the undoing of the South.** Since migration of slaveholders promoted a segregation of planters of the same class, moving under similar conditions and to the same section, it made reform almost an impossibility, and in preventing the im-

migration of white laborers into the slave States the system became so strongly entrenched that it had to be attacked from without. In the first place, in the effort to exploit black men it transformed white men into bloodthirsty beings. The system, moreover, promoted the formation of wasteful habits. It prevented the growth of towns and cities and shut out manufacturing, leaving the South dependent on the North or European nations for its manufactures. While the North was receiving an influx of free laborers the South was increasing unnecessarily its slave labor supply, indulging in unwise investments, and overstocking the markets with southern staple crops. In making labor undignified, moreover, it reduced the poor whites to poverty, caused a scarcity of money, cheapened land, and confined the South to one-crop farming at the expense of its undeveloped resources.

The economic interests of the two sections, therefore, began to differ widely during the thirties. When Missouri asked for admission to the Union, the struggle which ensued emphasized these differences. Prior to this **Differing interests.** period slavery had well established itself in that territory. When everything had been arranged and Congress was about to pass the bill providing for its admission, James Talmadge, a representative from New York, upset things by offering an amendment providing that slavery should not be allowed in that territory. This led to a fiery debate participated in by the stalwart defenders of the proslavery section of the country and by the Congressmen of the North, who although at that time unprepared to advocate a general abolition of slavery, were convinced that it was an evil and desired to prohibit its expansion. It was pointed out by the antislavery element that some of the State of Missouri lies farther north than the mouth of the Ohio River, above which slavery was prohibited by the

Ordinance of 1787 organizing the Northwest Territory.¹³

The main question was whether or not Congress had any right to limit a State coming into the Union. Decidedly it had, but it was necessary to argue the question. It was pointed out that in the admission of the State of Louisiana Congress imposed certain conditions requiring that the State should use the English language as its official tongue, should guarantee the writ of habeas corpus and trial by jury, and incorporate into its organic laws the fundamental principles of civil and religious liberty. They could have pointed out, too, that Ohio was required to comply with a number of requirements, among which was the use of certain of its lands in the Western Reserve and in the southeast.¹⁴

The antislavery group, moreover, contended that inasmuch as Congress is required by the Constitution to guarantee to each State a republican form of government it was necessary to prohibit slavery, which **Binding a State.** was incompatible with that form of government. The proslavery party supported their cause on the ground that to impose a restriction on a State would place it on a basis of inequality rather than that of equality with other States. The privileges enjoyed by one State should be enjoyed by all. If one had the right to hold slaves, all should enjoy the same privilege as they had when all were admitted to the Union. It was contended, moreover, that powers not delegated to the United States Gov-

¹³ There are discussions of the constitutional question growing out of slavery in Herman von Holst's *The Constitutional and Political History of the United States of America*, in John W. Burgess's *Middle Period* and his *Civil War and Reconstruction*, and in James Ford Rhodes' *History of the United States*, Chs. VI and VII. Burgess and Rhodes, however, are generally biased.

¹⁴ Restrictions were also imposed later on California when it was provided that the duties on goods imported there should have to be fixed according to terms set forth in the amendment to the regular navy act.

ernment nor prohibited to the States were reserved to the States. The question as to whether a State should hold slaves, therefore, was reserved to that commonwealth and Congress had no right to interfere therewith.

It was asserted also, as was admitted thereafter, that the restriction against slavery in the Ordinance of 1787 was not binding on those States of the territory that had been **The Ordinance of 1787.** admitted to the Union, and that they could introduce slavery when they desired.¹⁵ The proslavery leaders believed that the institution of slavery would be beneficial to the country rather than an evil, in that it would provide for an extension of the system, reducing the number held by each person and, therefore, bringing the slave into more direct and helpful contact with the master. The agitation was quieted for the time being, after the compromise permitting Missouri to come into the Union as a slave State but prohibiting the institution south of parallel thirty-six, thirty constituting the southern limit of Missouri.

Another important question came forward in the Missouri debate when the question had been all but settled, that is, when the State had framed a constitution in keeping with **The citizenship of Negroes.** the instructions given in the enabling act, but had incorporated into this document a clause providing for the exclusion of free Negroes from that commonwealth. This provision was seriously attacked by the friends of justice, arguing that inasmuch as these Negroes were citizens of the United States, no State had a right to restrict their privileges, as such action would conflict with the Constitution of the United States, which guarantees to the citizens of each commonwealth all the privileges and immunities of citizens in every other commonwealth. This drove home the real truth which the

¹⁵ J. P. Dunn, *Indiana; A Redemption from Slavery*, pp. 218-260; N. D. Harris, *The History of Negro Servitude in Illinois*, Chs. III, IV and V; and B. A. Hinsdale, *Old Northwest*, pp. 351-358.

country had not before realized, that there was such a thing as citizenship of the United States in contradistinction to citizenship in a State, and that the citizenship of the United States is more than citizenship of a State. When a citizen, therefore, immigrated into and settled in another State, he should not, according to the Constitution, lose the right to be treated as a citizen of that commonwealth. When this involved the rights of the Negro it was certainly startling to the representatives of the South; and Missouri, for that reason, if for no other, was less inclined than ever to change that provision of its Constitution. The matter was settled by a second compromise, to counteract the effect this clause might have, by providing that nothing therein contained should be so construed as to give the assent of Congress to any provision in the Constitution of Missouri which contravened that clause in the Constitution of the United States which declares that the citizens of each State shall be entitled to all of the privileges and immunities of citizens in the several States.

Slavery again showed its far-reaching effects. During the first three decades of the nineteenth century, the South, in the natural order of things, became a section dependent solely on its peculiar institution, a district devoted entirely to agriculture and **Slavery and the tariff.** almost solidly organized in defending such interests. For this reason the South developed into a mere plantation. The North, on the other hand, in view of the shipping industry, its commerce, and the manufacturing, which of necessity grew during the war of 1812 and decidedly expanded thereafter, developed a number of business and industrial centers desirous of protecting their industries by imposing certain duties on goods imported from Europe. This caused a shift in the positions of the leaders of these two sections. Whereas, in 1816, John C. Calhoun was an advocate of a protective tariff and Daniel

Webster was a free trader, in 1832 Webster was in favor of import duties and Calhoun had constructed a policy of free trade. With the support of the West, desiring a protective duty on its hemp and the like, the manufacturing districts were able to secure the enactment of tariff-for-protection measures in 1824, 1828 and 1832.¹⁶

Against the protective tariff the commonwealths of the South began to argue that it was discriminatory and therefore unconstitutional, in that it imposed a tax upon one **Opposition to the tariff.** section for the benefit of the other. Congress, as the South saw it, had no right to legislate in behalf of one section at the expense of the other. So bitter did the South become because of this seeming imposition that in 1832 South Carolina undertook to nullify the tariff law of 1832, believing very much as Kentucky and Virginia had in 1798, that a State had a right to obey or to nullify a law passed by Congress, if, in its judgment, it found out that that law was prejudicial to the interests of the State concerned.

It was made clear, moreover, that South Carolina was of the opinion that this country was not a Union but still a Confederation loosely held together very much as the **A union or a confederacy?** States were under the Articles of Confederation. A State, therefore, as long as it chose to be bound by the terms of the Constitution could continue to do so, but if at any time it felt that the union with the other States was undesirable, it could of itself or in connection with a number of States constituting a majority call a convention representing the same power by which the Constitution was ratified and declare the severance of the ties that bound them to the Union.

It was necessary, therefore, for the Union to take high ground for its own self-preservation. Although Andrew

¹⁶ See Calhoun's speech in the Appendix.

Jackson, then President of the United States, did not hold any brief for the tariff himself, he could not countenance the act of nullification. He, therefore, threatened to use force should South Carolina refuse to obey the laws of Congress. This matter, like others threatening the foundation of the Union, was settled by a compromise brought forward by Henry Clay to the effect that the duties would remain as they were under the law of 1832, but by a gradual process would be diminished until they reached the rates acceptable to South Carolina.

Slavery brought out also another economic question in connection with internal improvements. It was difficult for a slaveholding section to expand as rapidly as the manufacturing and commercial parts of the country. In this all but phenomenal growth of the United States **Internal** there was an urgent need for canals and roads **improvements.** to tap the resources of the interior. As the South in its slow development did not feel this need and thought that it would not generally profit by these improvements, it usually opposed them on the grounds that the United States Government had no authority to make such improvements and the States had not the required funds. This opposition resulted from the observation that these improvements were unifying influences which strengthened the Union at the expense of the South, which hoped to hold the axe of secession over the heads of the Unionists.

CHAPTER VIII

THE FREE NEGRO

WHILE the fate of the slaves in the South was being determined, there was also a considerable number of free persons of color whose status was ever changing. Few people now realize the extent to which the free Negro figured in the population of this country prior to the Civil War.¹ Before slavery was reduced from a patriarchial establishment to the mere business of exploiting men, a considerable number of Negroes had secured their freedom, and the fruits of the American Revolution, effective long thereafter in ameliorating their condition, gave an impetus to manumission. In some colonies Negroes were indentured servants before they were slaves, and became free upon the expiration of their term of service. The result was that there were in this country in 1790 as many as 59,557 free people of color, 35,000 of whom were living in the South. During the two decades from 1790 to 1810, the rate of increase of free Negroes exceeded that of the slaves, and the proportion of free Negroes in the black population increased accordingly from 7.9 per cent in 1790 to 13.5 per cent in 1810. After

¹ John H. Russell, *The Free Negro in Virginia, passim*; E. R. Turner, *The Negro in Pennsylvania*; F. U. Quillin, *The Color Line in Ohio, passim*; C. T. Hickok, *The Negro in Ohio, passim*; C. G. Woodson, *A Century of Negro Migration*, pp. 1-100; the *Journal of Negro History*, I, 1-68, 99-100, 203-242, 302-317, 361-376; II, 51-78, 164-185; III, 90-91, 196-197, 360-367, 435-441, and *Negro Population in the United States, 1790 to 1915*.

this date the tendency was in the other direction because of the reaction against the Negro, bringing about a restriction on manumissions.

Between 1810 and 1840 the Negro population almost doubled, but the proportion of the free Negroes remained about the same. Because of further restriction on manumission and the more secure foundation of economic slavery with rigid regulations to prevent the fugitives from escaping, this proportion of free Negroes in the black population decreased to 11.9 per cent by 1850 and to 18 per cent by 1860. While the Negro population as a whole doubled its percentage of increase, then, that of the free blacks declined. It became smaller in parts of the North and declined to one-fourth of the rate of increase between 1800 to 1810. In 1860 the rate of increase was about one per cent a year. It is worthy of note, however, that there were 434,455 free Negroes in the United States in 1850 and 488,070 in 1860. At this latter date 83,942 of these were in Maryland, 58,042 in Virginia, 30,463 in North Carolina, 18,467 in Louisiana, 11,131 in the District of Columbia, 10,638 in Kentucky; in short, 250,787 in the whole South.

This increase of free Negroes was largely a natural growth. There had been, of course, some additions by purchases of freedom and the acquisition of new territory. They did not immigrate into this country, for only 7,011 free Negroes enumerated in 1860 were born abroad. Some idea as to the extent other factors figured in this may be obtained from the fact that 1,467 Negroes were manumitted in 1859 and 1,011 became fugitives. In 1859 there were 3,000 manumissions and 803 fugitives. The census of 1860 reports that probably 20,000 manumissions were made during the decade between 1850 and 1860.

Increase a natural growth.

Census Year	Negro Population, 1790 to 1860							
	Total	Free		Decennial Increase				
		Number	Per cent	Number	Free	Slave	Per cent	
			Slave	Free	Slave	Free	Slave	
1860....	4,441,830	488,070	11.0	3,953,760	53,575	749,447	12.3	23.4
1850....	3,638,808	434,495	11.9	3,204,313	48,202	716,958	12.5	28.8
1840....	2,873,648	386,293	13.4	2,487,355	66,694	478,312	20.9	23.8
1830....	2,328,642	319,599	13.7	2,009,043	85,965	471,021	36.8	30.6
1820....	1,771,656	233,634	13.2	1,538,022	47,188	346,660	25.3	29.1
1810....	1,377,808	186,446	13.5	1,191,362	78,011	297,760	71.9	33.3
1800....	1,002,037	108,435	10.8	893,602	48,908	195,921	82.2	28.1
1790....	1,757,181	59,557	7.9	697,624

The statistics of the Negro population between 1790 and 1915 suggest as an explanation for this decrease that the free people of color were much older and therefore subject to a higher mortality rate; that they were less normally distributed by sex and therefore probably characterized by a marital condition less favorable to rapid natural increase. Among the free Negroes at each of the five censuses, from 1820 to 1860, there were fewer males than females, whereas the distribution as to sex among the slaves remained about equally divided between the two. While this does not altogether account for the disparity, it doubtless had something to do with the situation, for the Negroes manumitted were, as a majority, men, and those who contrived to escape were largely of the same sex. Furthermore, masters controlled the slave supply so as to add what number they needed from whichever sex seemed deficient.

The customs and regulations restraining the slaves did not generally apply to the free people of color even when so provided by law. Some of them were closely connected with their masters, who gave them more consideration than that shown by many others who sold their own flesh and blood. In spite of the law to the contrary, a few such benevolent masters maintained schools for the education of their mulatto children. When that became unpopular they were privately instructed or sent to the North for education. Charleston, South Caro-

lina, affords a good example of the interest manifested in the free people of color by the attitude of citizens, who winked at the efforts of the free blacks to educate their children in well-organized schools in defiance of the law. In the State of Louisiana, where many of these mixed breeds were found, their fathers sometimes sent them to Paris to avail themselves of the advantages of the best education of that time.

These free Negroes were not all on the same plane. In the course of time they experienced a development of social distinction which largely resembled that of the whites. There were freedmen in possession of a considerable amount of property, others who formed a lower class of mechanics and artisans, and finally those living with difficulty above pecuniary embarrassment. Among those in the large cities social lines were as strongly drawn as between the whites and the blacks, and the antipathy resulting therefrom was hardly less.

The well-to-do free Negroes were not merely persons with sufficient property to form an attachment to the community. Many of them owned slaves, who cultivated their large estates. Of 360 persons of color in **Progressive freedmen.** Charleston, 130 of them were, in 1860, assessed with taxes on 390 slaves. In some of these cases, as in that of Marie Louise Bitaud, a free woman of color in New Orleans, in 1832, these slaves were purchased for personal reasons or benevolent purposes, often to make their lot much easier. They were sometimes sold by sympathetic white persons to Negroes for a nominal sum on the condition that they be kindly treated.

Some of these instances are enlightening. A colored man in 1818 bought a sailmaker in Charleston. Richard Richardson sold a slave woman and child for \$800 to Alexander Hunter, guardian of the Negro freeman Louis Mirault of Savannah. Anthony Ordingsell, a free man of color, sold

a slave woman in the same city in 1833. A Charleston Negro who purchased his wife for \$700 sold her at a profit of \$50 because she would not behave herself. To check this, laws restricting manumission, as in Virginia in 1806, were enacted to limit this benevolence of white men by imposing difficult conditions. Thereafter these freedmen were to be sent out of the State unless their former master agreed to support them.

Some other Negroes of less distinction accomplished much to convince the world of the native ability of the Negroes to extricate themselves from peculiar situations and to make progress in spite of opposition. **Undistinguished free Negroes.** Samuel Martin, a benevolent slaveholder of color residing at Port Gibson, Mississippi, purchased his own freedom in 1829, and thereafter purchased two mulatto women with their four children, brought them to Cincinnati in 1844, and emancipated them. Another Negro named Creighton, living in Charleston, South Carolina, accumulated considerable wealth which he finally decided to devote to the colonization of the Negroes in Liberia. He disposed of his property, offering his slaves the alternative of being liberated on the condition of accompanying him to Africa or of being sold as property. Only one of his slaves accepted the offer, but he closed up his business in Charleston, purchased for the enterprise a schooner of his own, and set sail for Liberia in 1821.

Among the prosperous free Negroes in the South may be mentioned Jehu Jones, the proprietor of one of the most popular hotels in Charleston and owner of forty thousand **Wealthy persons of color.** dollars worth of property. There lived Thomy Lafon in New Orleans, where he accumulated real estate to the amount of almost half a million dollars, and in the same city a woman of color owning a tavern and several slaves. A Negro in St. Paul's Parish, South Carolina, was said to have two hun-

dred slaves, and a white wife and son-in-law, in 1857. In 1833 Solomon Humphries, a free Negro well known by men of all classes in Macon, Georgia, kept a grocery store there and had more credit than any other merchant in the town. He had accumulated about twenty thousand dollars worth of property, including a number of slaves. Cyprian Ricard bought an estate in Iberville Parish, with ninety-one slaves, for about \$225,000. Marie Metoyer, of Natchitoches Parish, possessed fifty slaves and an estate of more than 2,000 acres. Charles Rogues of the same community left in 1848 forty-seven slaves. Martin Donato, of St. Landry, died in 1848, leaving a Negro wife and children possessed of 4,500 arpents of land, eighty-nine slaves and personal property worth \$46,000.

These Negroes, however, were exceptions to the rule. Most well-to-do free Negroes in urban communities belonged to the artisan class, and there were more of them than one would think. In southern cities most of the work in the mechanic arts was done by **Prosperous mechanics.** the slaves, as there was less discrimination in this field in the South than in the North. Contrasting the favorable conditions of southern Negroes with that of those in the North, a proslavery man referred to Charleston, South Carolina, as furnishing a good example of a center of unusual activity and rapid strides of thrifty free Negroes. Enjoying these unusual advantages, the Negroes of Charleston were early in the nineteenth century ranked by some as economically and intellectually superior to any other group of such persons in the United States. A large portion of the leading mechanics, fashionable tailors, shoe manufacturers, and mantua-makers were free Negroes, who had "a consideration in the community far more than that enjoyed by any of the colored population in the northern cities."

What then was the situation in the North? The fugitive slave found it difficult. Most Negroes who became free as

a result of manumission had been dependents so long that they lost their initiative. When thrown upon their own resources in the North where they had to make opportunities, they failed. In increasing the number of those seeking **Hardships in economic opportunities in the North, more-**
the North. over, they so cheapened the labor as to make it difficult for the free Negroes already there to earn a livelihood. They were, therefore, branded by the writers of the time as the pariahs of society. There was, in fact, as much prejudice against the free Negroes in parts of the North as in the South. This feeling, however, resulted largely from the antipathy engendered by the competition of the Negroes with the large number of Germans and Scotch-Irish immigrating into this country a generation before the Civil War.

Some few Negroes facing these conditions returned South and reënslaved themselves rather than starve in the North. A larger number in the South, however, were en-
The return to slaved against their wills for such petty of-
the South. fenses as theft and the like, which almost any poverty-stricken man would be liable to commit. They were ordinarily arrested as suspected fugitives, or for vagrancy and illegal residence, and finally sold for jail fees. As Negroes in these cases were not allowed to testify in their own behalf, the official arresting a free Negro generally preferred against him whatever charge best suited his convenience and disposed of the Negro accordingly. Eighty-nine were sold in Maryland under the act of 1858 justifying such reënslavement. Much of this repression was instituted for intimidation to keep the free Negroes down that they might never join with slaves in an insurrection.

How did the situation of the free Negro compare with that of the white man? In the first place, the freedman
Restrictions. was not a citizen in any Southern State after 1834 and was degraded from that status in certain States in

the North. In most States free persons of color had with some limitations the right to own and alienate property, even to own and sell Negro slaves. Early statutes and customs, however, prohibited them from owning whites as servants, and during the intense slavery agitation of the thirties this right of holding Negroes as slaves was gradually restricted to whites because of the benevolent use made of it by certain Negroes, who purchased more than their wives and children. For fear of improper uses, too, free Negroes in the South were not allowed to own such property as firearms, dogs, firelocks, poisonous drugs and intoxicants. As they were prohibited from serving in the State militia, they would have no need for firearms. The Negro, moreover, had a weak title to property in himself. If the Negro's right to be free were questioned, the burden of proof lay on him.

In some cases, however, the free Negroes had a little chance in the courts. The freedmen had the remedy of *habeas corpus*. They could bring suit against persons doing them injury, and in the case of seeming injustice in a lower court they could appeal to **Some** a higher. When charged with crime the free Negro had the right to trial by jury and could, after indictment, give bond for his liberty. The right of jury trial was after Nat Turner's insurrection in 1831 restricted in several southern States to cases punishable by death. It must be remembered, however, that the Negro could not expect a fair trial; for, consistent with the unwritten primitive law of the white man in dealing with the blacks, judgment preceded proof. In the case of ordinary misdemeanors the lot of the free Negroes was no better than that of the slave. Corporal punishment in these cases was administered to the Negroes without stint, whereas a white man guilty of the same offense would be requested to pay a fine. In most cases of felony the punishment for a white man and a free Negro **privileges.**

was the same in the beginning, but the reaction brought on certain distinctions.

At times the free Negroes could go and come to suit themselves. During the ardent slavery agitation, however, it was necessary for them to exhibit their free papers when questioned. They were later restrained from moving from one **Egress and** State to another or even from one county to **regress.** another without securing a permit. In some southern States, nearer the middle of the nineteenth century, it was unlawful for a free Negro to return to the State after leaving, as he might be spoiled by contact or education.

Although forcing the free Negroes to a low social status, the local government did not exempt them from its burdens. In Virginia, free Negroes were required to pay a poll tax of \$1.50 in 1813 and \$2.50 in 1815. In 1814, 5,547 free Negroes in that State paid \$8,322 in taxes, and in 1863 they paid \$13,065.22 in poll taxes. The Negroes in Baltimore paid \$500 in school taxes in 1860, although their children could not attend the city schools. Most States taxed the free Negroes inconsistently in the same way.

Socially, the Negro, whether slave or free under the economic régime, was an outcast. Prejudice based on color rather than on condition made him an object of opprobrium **The Negro** in the nineteenth century, in contradistinction **an outcast.** to his condition a hundred years earlier. In the seventeenth century there followed miscegenation of the races. In the eighteenth century free Negroes still experienced some interbreeding and moved with the whites socially in certain parts. In the nineteenth century all social relations between the whites and the free Negroes became about the same as those of the former with the slaves.

No laws prevented the intermarriage of the free Negroes

and Indians. Squaws accepted Negroes for husbands, and Indian men commonly had black wives. Extensive miscegenation of these stocks was experienced in most States in the South. As these two races were in common undesirables among the whites, the one early manifested sympathy for the other, as was evidenced by the fact that in the massacre of 1622 in Virginia not an African was killed. In the raids of the Indians on the settlers of Louisiana, Negroes often acted in concert with them. Efforts had to be made to separate the Negroes from the Indians, when the former eagerly resorted to their reservations as places of refuge. In some cases the Negroes on these estates survived the Indians, who became extinct.

Out of these unions came a class of Negroes commonly known as the mustees, or mestizos, and it became necessary for laws and legal documents citing persons of color to give in detail all of these various designations. No distinction was later made between them and other persons of color, however, and they passed as a part of the free Negro population. Evidences of their presence in Virginia appeared at an early date. In 1734 John Dingie, an Indian of King William County, married Anne Littlepage, a mulatto daughter of the wealthy Edmund Littlepage. He himself was occupied as a sailor, and his wife, a free woman, was the heir of considerable wealth.

Free Negroes mingled more with the slaves, however, than with any other class. This was not the condition in the beginning, but in the course of time, when the free Negroes dwindled in number and their chances for education and the accumulation of wealth grew less, the social distinctions between them and the slaves diminished and they associated with and married among them. This became common in the nine-

**Interbreeding
with the
Indians.**

**Mustees and
mestizos.**

**Relations of
free Negroes
and slaves.**

teenth century. In fact, when the question of employment became serious, it was often advantageous for a free Negro to marry a slave wife. This attachment too often prevented a free Negro from being expelled from the State by the hostile laws when he had this all but permanent connection with the community. A master would not force him to leave for fear that he might induce his family to escape. Some slaves disliked free Negroes because conditions had made the former apparently the inferiors of the latter.

The accomplishment of this task of reducing the free people of color almost to the status of the slaves, however, was not easy. In the first place, so many persons of color **Exceptions to the rule.** had risen to positions of usefulness among progressive people and had formed connections with them that an abrupt separation was both inexpedient and undesirable. Exceptions to the hard and fast rules of caste were often made to relieve the people of color. The miscegenation of the races in the South and especially in large cities like Charleston and New Orleans, moreover, had gone to the extent that from these centers eventually went, as they do now, a large number of quadroons and octoroons, who elsewhere crossed over to the white race. As the status of the Negroes remained fixed, however, while that of the poor whites changed, the close relations formerly existing between these classes gradually ceased.

The free Negro was in many respects a disturbing factor in the economic system. White laborers did not care to compete with them. The free Negro usually won in the **A disturbing factor.** contest, for the reason that his standard of living was lower and he could work for less. Moreover, being almost defenseless before a hostile public, he could be more easily cheated and was, therefore, to be preferred. According to testimony, however, they were of economic worth. Yet others called them idlers, criminals, vicious vagabonds, a vile excrecence and the like. These

opinions may not be taken seriously when there are so many others to the contrary.

In the North the Negroes were likewise socially and, in addition to this, economically proscribed. Yet they usually succeeded in permanently establishing themselves wherever they had an opportunity.²

**Successful
Negroes.**

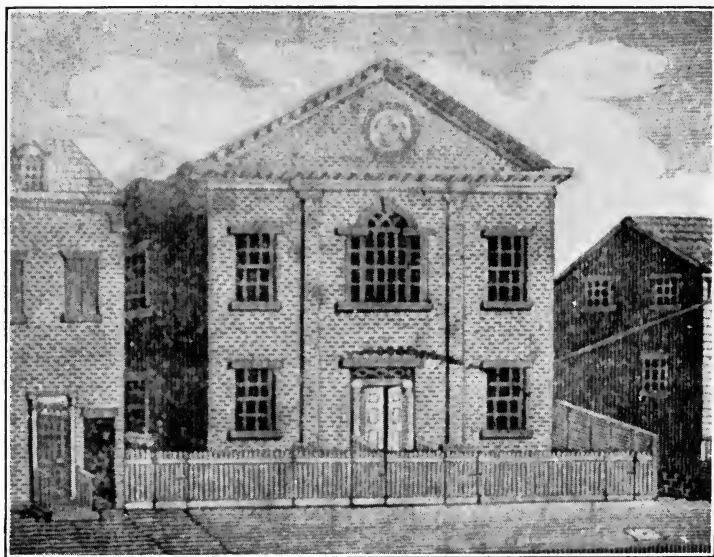

NEW YORK AFRICAN FREE SCHOOL, No. 2, built a century ago

Joseph C. Cassey and William Platt became enterprising lumber merchants in Western New York; Henry Topp came forward as a leading merchant tailor in Albany, and Henry Scott of New York City founded and promoted for a num-

² For other instances of free Negroes making economic progress, see William Wells Brown's *The Black Man*, M. R. DeLany's *The Condition of the Colored People of the United States*, Alexander Mott's *Biographical Sketches*, W. J. Simmons's *Men of Mark*, C. G. Woodson's *A Century of Negro Migration*, and *The Journal of Negro History*, under the caption *Undistinguished Negroes*,

ber of years one of the most successful pickling establishments in that metropolis, while along with him arose Thomas Downing, a caterer, and Edward V. Clark, a prosperous jeweler. Other Negroes were building churches, establishing schools, and editing newspapers promoting the interests of the people of color.

In Pennsylvania, where Negroes were found in large numbers, more evidences of progress were noted. The Negroes of Philadelphia had taxable property to the amount of \$350,000 in 1832, \$359,626 worth in 1837, and \$400,000 worth in 1847. They had established before emancipation more than a score of churches with which were connected more than a hundred benevolent societies and a number of schools. Five hundred of these Negroes were mechanics, and a considerable number ranked as business men. Among the latter were James Forten, a sail manufacturer, Joseph Casey, a broker, and Stephen Smith, a lumber merchant. William Goodrich of York was investing in railroad stock. Benjamin Richards of Pittsburg was accumulating wealth in the butchering business, and Henry M. Collins of the same city was developing a real estate enterprise of considerable proportions.

FREEDOM'S JOURNAL.

RIGHT-QUOTES EXALTBETH A NATION

NEW-YORK, FRIDAY, MARCH 30, 1827

[Vol. I. No. 3.]

MEMBERS OF CAPT. PAUL CUFFEE

Being the month of a cruel winter... about a person, and made a person... of a person, and made a person...

And the second Paul formed a connection... with a brother in the N. West... the first of the month...

And the third Paul formed a connection... with a brother in the N. West... the first of the month...

And the fourth Paul formed a connection... with a brother in the N. West... the first of the month...

(To be Continued.)

PEOPLE OF COLOUR.

Persons of colour are to be... in the... of a person...

And the first Paul formed a connection... with a brother in the N. West... the first of the month...

And the second Paul formed a connection... with a brother in the N. West... the first of the month...

And the third Paul formed a connection... with a brother in the N. West... the first of the month...

And the fourth Paul formed a connection... with a brother in the N. West... the first of the month...

(To be Continued.)

Persons of colour are to be... in the... of a person...

And the first Paul formed a connection... with a brother in the N. West... the first of the month...

And the second Paul formed a connection... with a brother in the N. West... the first of the month...

And the third Paul formed a connection... with a brother in the N. West... the first of the month...

And the fourth Paul formed a connection... with a brother in the N. West... the first of the month...

(To be Continued.)

Persons of colour are to be... in the... of a person...

And the first Paul formed a connection... with a brother in the N. West... the first of the month...

And the second Paul formed a connection... with a brother in the N. West... the first of the month...

And the third Paul formed a connection... with a brother in the N. West... the first of the month...

And the fourth Paul formed a connection... with a brother in the N. West... the first of the month...

(To be Continued.)

Persons of colour are to be... in the... of a person...

Printed and published for the proprietors of the Free Negro Journal, by William C. Co., Springfield, Mass.

CHAPTER IX

BLAZING THE WAY

THE free Negroes, moreover, exhibited not only the power to take care of themselves in old communities, but blazed the way for progress of the race in new commonwealths and in all but forbidden fields. In the Northwest Territory, where many free Negroes from the South were colonized, their achievements were no less significant. Luke Mulber came to Steubenville, Ohio, in 1802, hired himself out to a carpenter for ten dollars a month during the summer and went to school in the winter. At the expiration of three years he could do rough carpentry work and had about mastered the fundamentals of education. With this as a foundation he rose to a position of usefulness among the people of his town. Becoming a contractor, he hired four journeymen and did such creditable work that he was often called upon to do more than he could. David Jenkins, of Columbus, Ohio, was then a wealthy planter, glazier, and paper hanger. One Hill of Chillicothe was its leading tanner and currier.

In Cincinnati, where, as a group, the Negroes had their best opportunity, many made rapid strides forward. By 1840 the Negroes of this city had acquired \$228,000 of real estate. One Negro was worth \$6,000; another, who had purchased himself and family for \$5,000 a few years prior to 1840, was worth \$1,000. Another Negro paid \$5,000 for himself and family and bought a home worth \$800 to \$1,000. A freedman who was a slave until he was twenty-four years of age, then had two lots

worth \$10,000, paid a tax of \$40, and had 320 acres of land in Mercer County, Ohio. His estate altogether was worth about \$12,000 or \$15,000. A woman who was a slave until she was thirty then had property worth \$2,000. She had also come into potential possession of two houses, on which a white lawyer had given her a mortgage to secure the payment of \$2,000 borrowed from this thrifty woman. Another Negro, who was on the auction block in 1832, had



A SECONDARY SCHOOL IN MERCER COUNTY, OHIO, admitting Negroes in 1842

spent \$2,600 purchasing himself and family and had bought two brick houses, valued at \$6,000, and 560 acres of land, said to be worth \$2,500, in Mercer County, Ohio.

Out of this group in Cincinnati came some very useful Negroes, among whom may be mentioned Robert Harlan, the horseman; A. V. Thompson, the tailor; J. Presley and Thomas Ball, contractors; and Samuel T. Wilcox, the merchant, who was worth \$60,000 in 1859. There were among them two other successful Negroes, Henry Boyd and Robert Gordon. Boyd was a Kentucky freedman

Statistics.

who helped to overcome the prejudice in Cincinnati against Negro mechanics by inventing and exploiting a corded bed, the demand for which was extensive throughout the Ohio and Mississippi Valleys. He had a creditable manufacturing business in which he employed twenty-five men.

Robert Gordon, the other Negro there, was doubtless a more interesting character. He was born the slave of a rich yachtsman in Richmond, Virginia. His master placed **A shrewd business man.** him in charge of a coal yard, which he handled so faithfully that his owner gave him all of the slack resulting from the handling of the coal. This he sold to the local manufacturers, accumulating thereby in the course of time thousands of dollars. He purchased himself in 1846 and after inspecting several Negro settlements in the North went into the coal business in Cincinnati. Having then about \$15,000, Gordon made much more progress in this coveted enterprise than his competitors desired. They thereupon reduced the price of coal so as to make it unprofitable for Gordon to continue in the business. He was shrewd enough to fill all of his orders at the white coal yards by making his purchases through mulattoes who could pass for white. Soon there followed a general freezing on the Ohio River, making it impossible to bring coal down the river. Gordon then sold out his supply at advanced prices, so increasing his wealth that he was later in a position to invest extensively in United States bonds during the Civil War and afterward in real estate on Walnut Hills in Cincinnati.

This economic progress would have been greater, had it not been for race riots in communities in which free Negroes lived. On January 1, 1830, a mob drove eighty Negroes from Portsmouth, Ohio; 1,200 Negroes left Cincinnati **Riots.** for Canada as a result of the riot of 1829, and others lost life and property in the riots of 1836 and 1841. The disastrous effects of this unsettled state were further ag-

gravated by the Fugitive Slave Law of 1850. Many fugitives and their relatives residing in the free States moved immediately into Canada after the proclamation of this measure as the law of the land. Within thirty-six hours thereafter forty Negroes left Massachusetts for Canada. The Negro population of Columbia, Pennsylvania, decreased from 943 to 437. A Negro settlement at Sandy Lake in the northwestern part of that State was broken up altogether. Every member of a Negro Methodist Church, eighty-two in number, including the pastor, fled from a town in New York to Canada. The Negro churches of Buffalo lost many communicants. One in Rochester lost one hundred and twelve, including the pastor, and another in Detroit eighty-four. Some Negroes stood their ground and gave battle, as in the case of the Christiana tragedy in Lancaster County, Pennsylvania, where Edward Gorsuch was killed and his son wounded by free Negroes whom he wanted to enslave.

Those Negroes who dared to remain in the free States to defy the slave catchers were not thereafter in a frame of mind to promote their economic welfare, so great was the demand on their time for maintaining their freedom. In fact, the main concern of many leaders among the free Negroes and their sympathizers was aiding fugitives to reach free soil. William Craft, escaping from Macon, Georgia, with his handsome quadron wife who effected their escape by posing as his owner, caused unusual excitement in the North until this heroic dash for freedom ended with their flight to England. Then followed the arrest of Daniel as a fugitive in Buffalo, where the federal commissioner remanded him to his claimant. Hamlet was captured by his pursuers in New York City while the arrest of Jerry in Syracuse was stirring the whites and blacks throughout the North. Shadrach, claimed as a

**The Fugitive
Slave Law.**

**Personal
freedom
a concern.**

**Seeking
fugitives.**

slave in Boston, was imprisoned but almost miraculously spirited away to Canada. Thomas Simms, arrested later, however, was returned to slavery to please those who feared the southern threats of secession if the Fugitive Slave Law was not enforced, and to satisfy Boston business men who



ELLEN CRAFT, a fugitive disguised as her master

did not care to lose their trade with the South. Then for a similar reason came the return of Anthony Burns, a Baptist clergyman, arrested at the instance of Charles F. Suttle of Virginia, while two hundred special policemen had to be sworn in to restrain citizens who considered the law an infringement upon personal liberty. The Dred Scot decision, denying that the Negroes were citizens and making slavery national and freedom sectional, was the climax of these invasions of human rights.

Thousands of fugitives, however, were never apprehended. They were generally well directed through the free States by the agents of the Underground Railroad conducted by Quakers and militant abolitionists. This was not any well-known route controlled by a well organized body. It was rather a number of

Christian people scattered throughout the free States but united with their common purpose to promote the escape of slaves by clandestine methods in defiance of the mediæval

laws of the United States. There were near the border important stations which were always furnishing much excitement in the pursuit and capture, as related by William Still, in charge at Philadelphia, Levi Coffin, the station master at Cincinnati, and William Whipper, the moving spirit at Columbia, Pennsylvania.

Effective work was done in the Northwest Territory.

Through this section extended numerous routes from Kentucky and Tennessee to Canada. Josiah Henson and Harriett Tubman used these routes in conducting fugitives to freedom. The career of the latter in this hazardous enterprise was unusually romantic. Born a slave in Maryland but endowed with too much love of freedom not to break the chains which held her, she became in the North the most venturesome worker in the employ



WILLIAM STILL, an agent
of the Underground
Railroad

of the Underground Railroad. When her coworkers had much fear as to her safety, she dared to go even into the very heart of the South. Once she returned to her old home in Maryland, where she met her master along the road but easily contrived to prevent him from recognizing her. She did so much to aid the escape of fugitives and to rescue freedmen from slave hunters that the aggrieved owners offered for her capture a reward of \$40,000. For these unusual exploits she became known as the "Moses" of her people.

After the first excitement caused by the execution of the Fugitive Slave Law, conditions became a little more favorable for the Negroes in the North. Forcing upon the coun-

try a radical proslavery policy which men formerly indifferent as to the issue could not accept, the southern leaders made friends for the Negroes in the North. The effort to impress the North into the service of recapturing fugitive blacks, tended to raise up champions of individual liberty. The North had enacted personal liberty laws to



MYRTILLA MINER

counteract this slave-hunting, but these had failed. Sympathetic whites could not then go into the heart of the South to aid the blacks, but in the border States, and especially in cities like Baltimore and Washington, much was done for the improvement of Negroes through the many churches and schools established for their special benefit. Among many other workers promoting this cause was Myrtilla Miner, for years a teacher of girls of color in the District of Columbia and the

founder of the first girls' school of methods in Washington.

In spite of all of their difficulties some of the northern free Negroes attained national prominence.¹ Among those to appear after the reaction was John B. Russwurm, the first Negro college graduate, a classmate of John P. Hale at Bowdoin in 1826. Russwurm later went to Liberia and

¹ These persons of color are given more honorable mention in Simmons's *Men of Mark*, in William Wells Brown's *The Black Man*, and in his *Rising Son*.

served as governor. Dr. James McCune Smith, a distinguished graduate in medicine of the University of Glasgow and for years a practitioner in the city of New York, was better educated than Russwurm. Dr. Smith was a mixed breed of about equal proportion of Caucasian and African blood. In stature he was somewhat thick and corpulent. He had a fine head with a broad and lofty brow, round, full face, firm mouth, and dazzling eyes. As an educated man given to writing, he was easily drawn into the discussion on the race question, which his knowledge of history, science, and literature enabled him to treat in a scholarly way. He was also an eloquent speaker who always made himself clear and talked to the point.

**Prominent
Negroes.**

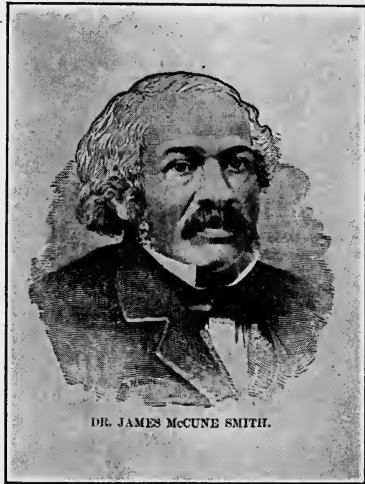

DR. JAMES McCUNE SMITH.

DR. JAMES McCUNE SMITH

In the field of writers there stood two other men as the first actual historians produced by the race. These were William C. Nell and William Wells Brown. There was then so much talk about the Negroes that men wanted to know more about the achievements of the race. These writers supplied this need. Nell was a native of Boston, a man of medium height, slim, genteel figure, quick step, elastic movements, a thoughtful yet pleasant brow, and thin face. Chaste in his conversation and devoted to literature, he passed as a man of learning with the reputation of being a person of unimpeachable character. Nell wrote a book, entitled *Colored Patriots of the American*

**William C.
Nell.**

The Negro In Our History

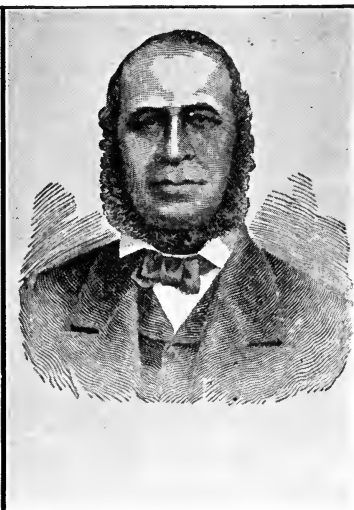
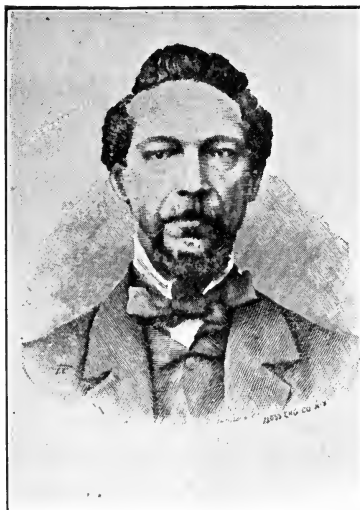
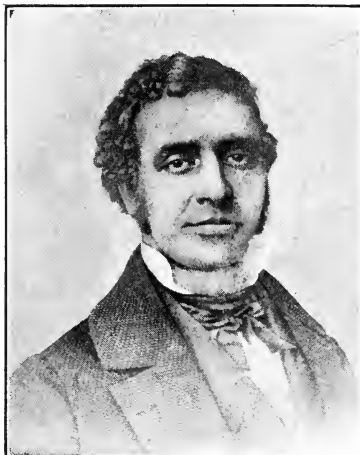

FREE NEGROES IN THE CRISIS
CHARLES L. REASON
PHILLIP A. BELL

WILLIAM WHIPPER
CHARLES B. RAY

Revolution, a volume containing numerous facts of the history of the race. He wrote other books of less importance and collected data which made him the best informed man in this field during his time.

William Wells Brown, the other writer, was born in

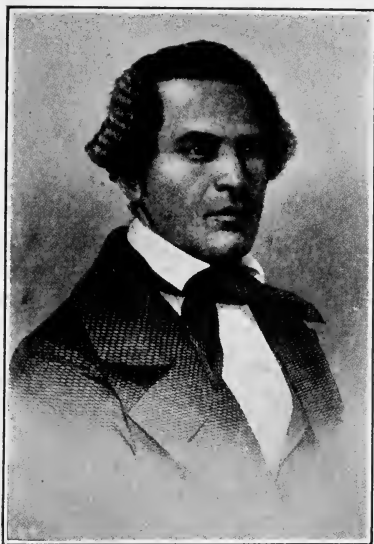

WILLIAM WELLS BROWN

Lexington, Kentucky, in 1816. His mother was a slave and his father a slaveholder. Serving in St. Louis in an office of Elijah P. Lovejoy before the editor was forced to go to Alton, Brown received his inspiration and start in education. He escaped North, where **William** he took an **Wells Brown**.

active part in the work of the Underground Railroad. From 1843 to 1849 he served as a lecturer of the American Antislavery Society. He then visited England and France, where he came into contact

with such lovers of freedom as James Houghton, Richard Cobden, Victor Hugo, and M. De Tocqueville, as set forth in his *Three Years in Europe*. Brown then published *Clotelle; or the President's Daughter*, a narrative of slave life in the Southern States. He studied medicine during these years, but never practiced much, as he was busily engaged in advancing the cause of freedom. He was a regular contributor to the *London Daily News*, *The Liberator*, *Frederick Douglass's Paper*, and *The National Anti-Slavery Standard*. In 1854 Brown published *Sketches of Places and People*

Abroad. His claims as an historian, however, are based on *The Black Man*, which appeared in 1863, *The Negro in the Rebellion*, published in 1866, and *The Rising Son*, brought out in 1882. Up to that date he had done more than any other writer to popularize Negro history.

There were at this time before the American public a number of other prominent Negroes ministering to other needs wherever necessary. There appeared Ira Aldridge, the successful Shakespearean actor; Edmonia Lewis, the



ALEXANDER CRUMMELL

sculptor; Edwin M. Bannister and William H. Simpson, painters of promise; Phillip A. Bell and Samuel E. Cornish, talented editors of the *Colored American*; James M. Whitfield and Frances E. W. Harper, writers of popular verse; Charles L. Reason, the educator called in 1849 to the chair of Mathematics and Belles Lettres of New York Central College; and George B. Vashon, a

graduate of Oberlin, admitted to the bar in 1847, but rather devoted to education at New York Central College, where he distinguished himself in teaching the classics.

Some of the useful preachers were William P. Quinn, Alexander W. Wayman, Jabez Campbell, Daniel A. Payne, Peter Williams, William Douglas, Charles B. Ray, John F.

Prominent ministers. Cook, Alexander Crummell, and Henry Highland Garnett. Most of these clergymen, like the two last mentioned, rendered important service in higher positions after the Civil War. Alexander Crummell, a man of unadulterated blood, attracted unusual attention by happily combining with his commanding appearance and fluent speech a liberal education in the classics and

theology obtained at Cambridge University, England. He made an impression by delivering in England in 1848 an address on the life and character of Thomas Clarkson. Crummell emigrated to Africa in 1852, but returned to this country in 1873.

One of the Negro students, because of whom the Canaan Academy in New Hampshire was closed, was Henry High-



HENRY HIGHLAND GARNETT

land Garnett, the son of a kidnaped African chief. He then sought education at the Oneida Institute under Beriah Green. He became a popular Presbyterian preacher and lecturer, but did not come into his own **Henry High-**
land Garnett.

until he delivered to the Convention of Colored Americans at Buffalo, in 1843, his famous address on the Negro. Recognized widely thereafter as

a man of influence on the platform, he went in 1850 to carry his message to England, from which he proceeded to Jamaica to serve as a missionary. He served as a Presbyterian minister in Washington and New York City, and for a few years was the President of Avery College.

In these ranks unselfishly toiled David Ruggles, J. W. C. Pennington, Samuel R. Ward, and Josiah Henson. Ruggles was a man of African blood, medium size, gentle address and polite language. He resided in **David**
Ruggles. the city of New York where he became an eternal enemy of slaveholders, bringing to that city servants, whose escape to freedom Ruggles often effected by

means of the Underground Railroad. Deeply interested in moral, social and political progress of the free Negro in the North, Ruggles published for several years *The Mirror of Liberty*, a quarterly magazine advocating the rights of the Negroes. In this work he exhibited unusual wit and logic in hurling blows at his opponents, as is well evidenced by his pamphlet, entitled *David M. Rees, M.D., Used Up*. In this Ruggles exposed the fallacy of the ardent colonizationists who had advocated the expatriation of the Negroes.

J. W. C. Pennington was born a slave in Maryland. He was a man of common size, of unadulterated blood and of strongly marked African features, slightly inclined to corpulency, with an athletic frame and a good constitution. He had no opportunities for early education, but after his release from bondage he so applied himself to the study of the languages, history, literature and theology that he became a proficient preacher in the Presbyterian denomination. He served as pastor of a church in Hartford, Connecticut, where he won distinction as a preacher and a lecturer. He then made several trips to Europe to attend Congresses at Paris, Brussels and London. On these occasions he was invited to preach and speak before some of the most refined and aristocratic audiences of Europe. In recognition of his scholar-

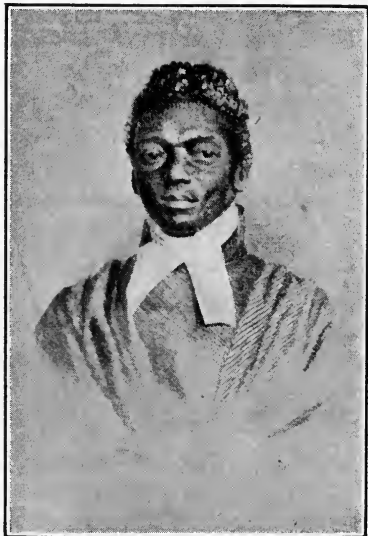

J. W. C. PENNINGTON

ship, the University of Heidelberg conferred upon him the degree of Doctor of Divinity.

Samuel R. Ward, thanks to aid received from Gerrit Smith, obtained a liberal education in the classics and in theology. For several years he acceptably served a white congregation of the Presbyterian denomination at South



SAMUEL R. WARD

Butler, New York. He was a black man, standing above six feet in height, distinguished by a strong voice, and energetic gestures. He shared with Fred Douglass the honor of being one **Samuel R. Ward.** of the most

popular orators of his day. He directed his appeal to the understanding rather than to the imagination; but, says a contemporary, "So forcibly did they take possession of it that the heart yielded." Ideas formed the basis of his method. His greater

strength lay in knowing that words and ideas are not inseparable. He never endeavored to be ornamental, although he was not inelegant. He was concise without being abrupt, clear and forcible without using extraordinary stress. Thus equipped for the deliverance of his great message, he preached or lectured in all the churches, halls and school houses in Western and Central New York. His work extended to other parts of the North and to Jamaica and England.

Josiah Henson had neither the intellect nor the natural

gifts of some of these men, but served as an example of the capability of the Negro. His experiences in slavery were **Josiah Henson**. so strange and peculiarly romantic that on hearing his story Mrs. Harriet Beecher Stowe reconstructed and embellished it so as to form the famous narrative known as *Uncle Tom's Cabin*. That he was the original Uncle



HARRIETT BEECHER STOWE

Tom, however, has been disputed. Josiah Henson settled in Canada and then rendered service in promoting the escape of 118 Kentucky slaves by means of the Underground Railroad through Ohio and Indiana. He thereafter devoted himself to preaching and education among his people, serving with Hiram Wilson as one of the founders of the British-American Manual Labor Institute. He engaged also in business in Canada, lectured throughout the North in behalf of the emancipation of the slaves, and finally visited England, where he was received by some of the leading men of that country and by Queen Victoria.

CHAPTER X

COLONIZATION

IN the proportion that slavery became an exploitation effort merely for the enrichment of the whites, the free Negroes who lived in the South became more and more undesirable in the eyes of the planters who had reduced the majority of slaves to the plane of beasts **The Cause.** of burden.¹ Debased also to a lower status, the free Negroes naturally thought of making an effort to extricate themselves from these untoward circumstances, remembering always their former state when slavery was of a patriarchal order. During the first two or three decades of the nineteenth century, therefore, they gradually found their way to the North, first by the aid of masters philanthropically inclined, especially the Quakers, who, seeing that their manumitted slaves had little chance for elevation in the midst of a slave society, sold out their holdings in the South and moved to the Northwest Territory where they undertook to establish them as freemen.

Another stage in the transplantation of the free Negroes was reached when because of their being apparently a menace to slavery the free Negroes were by legislation and pub-

¹ The story of colonization is given in documentary form in *The African Repository*, the official organ of the American Colonization Society. The attack on colonization is presented in William Jay's *An Inquiry Into the Character and Tendency of the American Colonization Society*. See also J. H. B. Latrobe's *Liberia; Its Origin, Rise, Progress and Results*; John H. T. McPherson's *History of Liberia*; Frederick Starr's *Liberia; Description, History, Problems*; C. G. Woodson's *Century of Negro Migration*, Chapter IV; and *The Journal of Negro History*, Vol. I, pp. 276-301, 318-338; II, 209-228.

lic opinion driven out of the South immediately or within a specified time. This forced into the North such a large number of free Negroes that there arose a strong protest from various communities, and some of them agitated prohibiting the immigration of Negroes into their commonwealths. Negroes were then coming into the North in larger numbers than could be easily absorbed, and coming, too, at the time when thousands of foreigners were immigrating into this country, they caused an intense race prejudice to develop against their group. From these two forces—that is, the effort to drive the Negroes from the South and the attempt to turn them away from the North—came a great impulse to the movement to colonize Negroes abroad. The condition of the free Negroes was such that it would seem that they should have been willing to go. They were proscribed by employers who preferred whites; they were denied consideration in the courts when they appealed to them for being imposed upon by ill-designing persons; and they were subject to the attacks of mobs spurred on to action by almost any petty offense committed by one of the free population of color.

The idea of colonization was not then new. From the very beginning of the antislavery movement there was an effort to provide for restoring the Africans to their native land. Such a scheme was developed by the Quakers under the inspiration of George Keith as early as 1713 and was forever thereafter kept before the people throughout America. In the beginning this idea was that of those persons sympathizing with the Negroes and desiring to ameliorate their condition by emancipation, but who were unable to think of incorporating them into their own society to live with the whites on a plane of equality.

The scheme was further advanced by Fothergill and Granville Sharp, and was given a new meaning by Anthony Benezet, who, having much confidence in the intellectual

power of the Negroes, felt that they might be colonized nearer to the white people. His proposal was that they should be settled on the western lands, which were ceded to the Congress of the Confederation. In this he was supported by a number of noted men of his time, chief among whom were Thomas Brannagan and Thomas Jefferson. During the Revolution, however, the manumissions of Negroes had led to the emancipation of a sufficiently large group of intelligent ones to justify the expectation that their liberation was not an experiment, should they be prepared by education and religious instruction; and the number of Negroes receiving their freedom during this time did not render an urgent agitation for the colonization of them abroad a necessity.

During the closing years of the eighteenth century and the first two decades of the nineteenth century, however, the desire for the colonization of the Negroes abroad became more widespread. Many slaveholders believed that the then ever-increasing important institution of slavery could be maintained only by removing from this country the most striking argument for its abolition, the free Negro; and the foreigners then crowding the free blacks out of the industries in the North hoped to remove them from the field of competition. Colonization, therefore, received a new impetus. The movement was no longer a means of uplift for the Negro but rather a method of getting rid of an undesirable class that slavery might be thoroughly engrafted upon our country.

Up to this time, however, there had not been any unifying influence to give the movement the support adequate to its success. The various advocates of the deportation of the Negroes had done little more than to express their views. A few had set forth some very elaborate plans as to how the machinery for the transportation of the Negroes abroad could be easily worked

**Promoters of
colonization.**

**Projects
abroad.**

**No concerted
action.**

out. Replying, in 1811, to Ann Mifflin, desiring an opinion on the matter of African colonization, Thomas Jéfferson said that he considered it the most desirable measure which could be adopted for the gradual drawing off of the black population. "Nothing," thought he, "is more to be wished than that the United States should thus undertake to make such an establishment on the coast of Africa." Unwilling, however, to content himself with this mere discussion, Paul Cuffe, a New England Negro known to the high seas, transported and established thirty-eight Negroes on the west coast of Africa in 1815. This was the first actual effort at colonization by Americans, and it served as an unusual stimulus to the movement. Cuffe recommended, however, that the region around the Cape of Good Hope be selected for colonization.

The colonization sentiment thereafter continued to grow. In the mountains of Tennessee and Kentucky, where the infiltration of slaves had made it impracticable for those emancipators in the mountains to continue to attack the institution, there developed a number of flourishing colonization societies which stimulated the movement. The Union Humane Society, an organization founded by Benjamin Lundy of Tennessee, had for one of its purposes the removal of Negroes beyond the pale of the white man. The same sentiment was expressed in Kentucky in its colonization society in 1812 and 1815, when it requested of Congress that some territory be "laid off as an asylum for all those Negroes and mulattoes who have been and who



PAUL CUFFE, the first actual colonizer

may thereafter be emancipated within the United States, and that such donations, allowances, encouragements, and assistance be afforded them as may be necessary for carrying them thither and settling them therein, and that they be under such regulations and government in all respects as your wisdom shall direct." Encouraged by Charles Fenton Mercer, a slaveholder of colonization tendencies, the Virginia Assembly, which, in 1800, had taken up with the President of the United States the question of colonizing emancipated slaves and free Negroes, passed a resolution in 1816 asking the American Government to find a place of asylum on the Northern Pacific coast on which to settle free Negroes and those afterwards emancipated in Virginia.

That very day a number of persons who had for years been interested in this movement met in Washington to effect a permanent organization. Among these persons who had fostered the cause of colonization was **Organization.** Robert Finley, a Presbyterian pastor who had served as president of the University of Georgia and had been in touch with Paul Cuffe. There appeared, too, Samuel J. Mills, a missionary and a promoter of all movements tending to uplift the man far down, Hezekiah Niles, the editor of the famous *Niles Register*, Elijah J. Mills, a Congressman of Massachusetts, and Elisha B. Caldwell, clerk of the United States Supreme Court. Among the men who attended the first meeting were Henry Clay, the compromiser, Francis Scott Key, the author of the Star Spangled Banner, John Randolph, a United States Senator from Virginia, Judge Bushrod Washington, a brother of George Washington, and Charles March, Congressman from Vermont. The first general conference of the colonizationists held in the home of Elisha B. Caldwell, was devoted largely to prayer for the success of the enterprise. Addresses were made by Henry Clay, discussing the delicacy of the question and expressing the purpose of the meeting and the con-

dition on which he had attended. The principal address, however, was delivered by Elisha B. Caldwell. Various views were expressed to indicate that although the members from the North had in mind the interests of the free Negroes, those from the South were primarily concerned with getting rid of this element.

Bushrod Washington was chosen president, and the machinery was constructed for the extension of the work of the Society into all States. In the course of time, therefore, we hear of several States having colonization societies, and in some of them they

Plans to extend colonization.

were organized in ordinary towns.

The purposes of these organizations varied according to the personnel of the management and the section of the country in which the Society was founded. The national organization established *The*



LOTT CARY

African Repository, the organ of the Society, and in that way made its declaration as to purpose to the whole world. Masters were not necessarily urged to free their slaves, but each community was called upon to take steps to provide for the transplantation to Africa of all slaves who might be liberated at the will of the masters concerned or purchased for this purpose, as was the case of Lott Cary, a Baptist preacher, who, in addition to rendering his denomination valuable service in Liberia, served

there creditably also as a governor of one of the provinces. The well-known promoter of colonization in later years was the successful lawyer and business man, John H. B. Latrobe, who, as secretary of the Maryland Colonization Society and finally President of the American Colonization Society, did more than any other individual to advance this cause.

It was finally decided to promote colonization in Africa. The United States Government was approached, and the matter received the attention of President Monroe, who submitted it to Congress. Upon his recommendation it was agreed to purchase in Africa certain territory lying near the Senegal River on the western coast. In making this purchase accordingly the country was designated as Liberia because it was to be the land of freedom. Its capital was called Monrovia in honor of James Monroe, the President of the United States under whom it was founded.

The problem then was to develop in this country a number of intelligent Negroes who might constitute a nucleus around which a government could be established. Here we see that the blacks were encouraged to develop the power to work out their own salvation. It gave an impetus to the movement for more thorough education of the Negroes at the very time when the South was trying to restrict them in such opportunities. Those Negroes to be sent out were to be trained in the manual arts, science, and literature, and in the higher professions. John B. Russwurm, an alumnus of Bowdoin, the first Negro to be graduated by a college in the United States, went as an educator to Liberia, where, after rendering valuable services as an educator and public functionary, he died.

**Preparation
of coloniza-
tionists.**

As the colonizationists had learned from experience that it was necessary to begin with the youth, better institutions of learning for Negroes were established for this purpose. Occasionally one would hear of a southern planter who

freed his Negroes and sent them to eastern schools to undergo such education as would prepare them for higher life in their new home in Africa. The Society, however, soon found itself in a dilemma of telling the people of this country that because the free Negroes were a depraved class they could not be elevated in this country, and at the same time encouraging these Negroes and their friends to promote the education of the few to be deported that they might have that same mental development which the whites in this country had experienced.

The colonizationists soon found themselves facing other difficulties. The very people for whom Liberia was established arrayed themselves against it.² It was in vain that some con-
Difficulties of tended that
colonization. it was a phil-

anthropic enterprise, since the meaning of colonization varied, on the one hand, according to the use the slave-holding class hoped to make of it and, on the other hand, according to the intensity of the attacks directed against it. The abolitionists and the free people of color opposed the Society because of the acquiescent attitude of colonizationists towards the persecution of the free blacks both in the North and the South. Almost before the colonization.

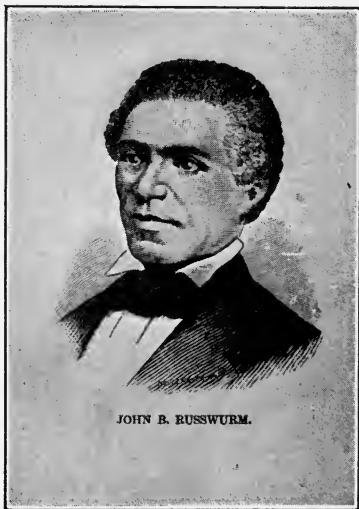

JOHN B. RUSSWURM.

JOHN B. RUSSWURM, first Negro to receive a degree from an American college

² L. R. Mehlinger, *The Attitude of the Free Negro Toward African Colonization in The Journal of Negro History*, Vol. I, pp. 276-301.

societies had been organized, therefore, the free people of color of Richmond, Virginia, thought it advisable to denounce the movement, saying that if they had to be colonized they preferred to be settled "in the remotest corner of the land of their nativity." They passed a resolution requesting Congress to grant them a portion of territory on the Missouri River.

About the same time about three thousand free Negroes of Philadelphia took even higher ground. They claimed this country as their native land because their ancestors were the first successful cultivators of its soil. **The protests of Negroes.** They felt themselves entitled to participation in the blessing of the soil which their blood and sweat had moistened. Moreover, they were determined never to separate themselves from the slave population of this country as they were brothers by "ties of consanguinity, of suffering and of wrongs." In 1831 a Baltimore meeting of free Negroes denounced the American Colonization Society as being founded more upon selfish policy than in the true principles of beneficence and, therefore, as far as it regards the life-giving principles of its operations, it was not entitled to their confidence and should be viewed by them "with that caution and distrust which happiness" demanded.

The free people of color in Boston inquired of those desiring to send them to Africa because they were natives of that land: "How can a man be born in two countries at the same time?" Referring also to the proposal to stop the slave trade by the establishment of a colony on the western coast of that continent, they said: "We might as well believe that a watchman in the city of Boston would prevent thievery in New York; or that the custom house there would prevent goods from being smuggled into any port in the United States." The Negroes of New York declared about the same time that the colonizationists were men of mistaken views, that their

offer to colonize the oppressed free people was unjust, and illiberal, tending to excite prejudice in the community. The free Negroes of Hartford, Connecticut, referred to the absurd idea of sending a nation of ignorant men to teach a nation of ignorant men. They asked, moreover, "why should we leave this land so dearly bought by the blood, groans and tears of our fathers? This is our home; here let us live and here let us die."

Some of the most distinguished men were effectively using the rostrum and press to impede the progress of the American Colonization Society. The best example of concerted action against the colonization movement, however, came from the annual convention of the free colored people held first in Philadelphia in 1830 and afterward in

Support of distinguished men. that and other cities annually until the

Civil War. The moving spirit of this enterprise was James Forten, ably assisted

by Robert Ray, James Cassey, Robert Purvis and James McCrummell. They early took the ground that they were unable to arrive at any other conclusion than that the doctrines which the society inculcated were "suitable to those who hold religion in direct violation of the golden rule, and that the inevitable tendency of this doctrine was to strengthen the cruel prejudice of their enemies and retard their advancement in morals, literature and science—in short, to extinguish the last glimmer of hope and throw an impenetrable gloom over their former and more reasonable prospects."

In 1852 there was held in Baltimore a pro-colonization meeting at which, after some discussion, it was decided to



ROBERT PURVIS

examine the different localities for migration, giving preference to Liberia. Liberia became the bone of contention, as very few Negroes were willing to go to that country and a majority of the Negroes in Baltimore were opposed to colonization of any sort. As these delegates had come from various parts of Maryland and did not voice the sentiment of the people of Baltimore, they were hissed and jeered from an outside meeting which developed almost into a mob, intimidating the delegates to the extent that they were not permitted to exercise that freedom of thought which the exigencies of the hour required. Another meeting of the Baltimore citizens denounced this assembly as unrepresentative and proceeded to proclaim the determination of the Baltimore people to oppose the policy of permanently attaching the free people of color to this country.

This feeling of antagonism of the free people of color manifested itself also in New York in 1848. W. S. Ball, who had been sent to Liberia by the free people of Illinois, undertook to report there to a colonization meeting as to the lay of the land. In expressing himself as to the attractions and opportunities of that country he was interrupted by one Morrell, who approached the platform and addressed the meeting, saying that the question as to colonization and the Liberia humbug had been settled long ago. The audience was then disturbed with hisses and jeers, and finally with yells for a fight, until the room was thrown into pandemonium and the meeting broken up in disorder.

Colonization seemed destined then to have rough sailing. Although the movement had the coöperation of an unusually large number of influential men both in the South and in the North, it failed to carry out the desired object of taking the free Negroes over to Africa. From 1820 to 1833 only 2,885 Ne-

Colonization in Baltimore.

An incident in New York.

The failure of African colonization.

groes were sent out by the Society. More than 2,700 of this number were taken from the slave States and about two-thirds of these slaves manumitted on the condition of their migrating. Of the 7,836 sent out of the United States by 1852, 2,720 were born free, 204 purchased their freedom, 3,868 were emancipated in view of removing them to Liberia, and 1,044 were liberated Africans sent out by the United States Government.

In the midst of the oppression of the free Negroes and the necessity for finding an immediate remedy, however, other schemes for colonization now came forward. There was proposed a colony of the Negroes in Texas, in 1833, prior to the time when the State became over-run with **Other** slaveholders. The opportunities of this coun-
schemes. try seemed to indicate that there was some reason for considering this plan feasible, but others thought that it would never suit Negroes because of the fugitives there from Mexico and the presence of a superior race of people there already speaking a different language and having a different religion. There was some talk, too, of the transplanting of a number of Negroes to British Guiana. It was thought that because Santo Domingo had become an independent republic, it would prove to be an asylum for the free people of color in this country, as Jefferson a number of years before had predicted.³

This tendency towards the West Indies was promoted by the dearth of labor there resulting from the emancipation of the slaves, which, thanks to the untiring efforts of **The danger of** Wilberforce and his coworkers, was effected
the exodus. by 1833. The West Indies offered inducements to Negroes immigrating into their country. Among these were Trinidad, which received a number of Negroes from Baltimore, Annapolis, and Philadelphia. Jamaica,

³ C. G. Woodson, *A Century of Negro Migration*, pp. 67-80.

with its many opportunities, placed her claims for these refugees and sent her agents into this country to proclaim the beauties of her civilization and the opportunities of the land. So favorable did this scheme become that the colonizationists had to redouble their efforts to prevent an unusually large number of Negroes from going to English-speaking colonies. Living on a plane of equality with the whites and enjoying the rights of citizens, they would as freemen become too powerful factors in the hands of the British, should they again undertake to wage war against the United States.

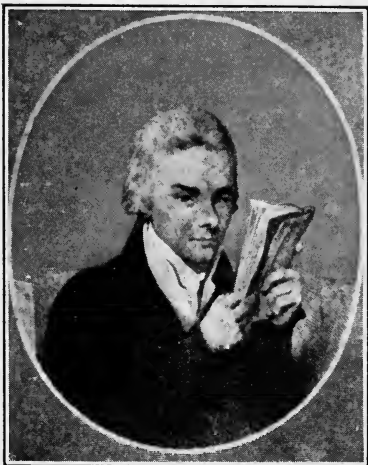

WILLIAM WILBERFORCE, the anti-slavery leader in England

The most successful colonization, however, was a sort of **Migration to Canada**, first proposed by Anthony Benezet, Thomas Brannagan and Thomas Jefferson. This was the migration to distant lands in America, especially to British Amer-

ica.⁴ Canada had served as an asylum for free Negroes who had made their escape into that country, but during the period of the cruel oppression of their class Negroes began to migrate there in large numbers. They secured land for farms, built homes, constructed churches, established schools and, in fact, covered a considerable portion of southern Ontario. In spite of the cold climate, the abolitionists and the free Negroes themselves usually con-

⁴ W. H. Siebert, *The Underground Railroad from Slavery to Freedom*.

sidered it more practical for Negroes to settle there than to avail themselves of the opportunities offered by the American Colonization Society in Africa.

Nearer to the Civil War there were established in Canada a number of Negro communities and towns. They exhibited the evidences of civilization found in other parts, and the **Progress in** Negroes themselves gave proof of what might **Canada.** be done, should their race as a whole be given the opportunity to make of itself what it would. They had learned to cultivate the soil, market their products, and engage in local manufactures. They were, moreover, not only coming into contact with the commercial centers of the United States but had begun to export and import from abroad. Out of these colonies in Canada emerged a number of intelligent Negroes who thereafter became factors in the progress of their race.

In the course of time, however, when the conditions of the free Negroes in Canada did not seem so inviting, a larger number of them began to think that colonization elsewhere **Recrudes-** was a necessity, although few of them believed **cence of** that they should go to Africa. To deal with **colonization.** this question there was organized in 1853 a national council of the leading Negroes, attracting representatives from as many as twelve State conventions. So divided on this question had the Negroes become, however, that only those persons who believed in colonization somewhere were asked to attend. Among the persons thus interested were William Webb and Martin R. Delaney, of Pittsburg, Doctor J. Gould Bias and Franklin Turner, of Philadelphia, Augustus R. Green, of Allegheny, Pennsylvania, James M. Whitfield, of New York, William Lambert, of Michigan, Henry Bibb, James Theodore Holly, of Canada, and Henry M. Collins, of California. Frederick Douglass, an uncompromising enemy to colonization, criticized this step as uncalled for, unwise, unfortunate, and premature.

“A convention to consider the subject of emigration,” said he, “when every delegate must declare himself in favor of it beforehand as a condition of taking his seat, is like the handle of the jug, all on one side.” James M. Whitfield, the writer of verse, came to the defense of his coworkers,

continuing a literary duel with Douglass for a number of weeks.

The convention was accordingly held. In it there appeared three parties, one led by Martin R. Delaney, who desired to go to the Niger Valley in Africa, another by James M. Whitfield, whose interests seemed to be in Central America, **Expeditions sent out.**

and a third by Theodore Holly, who showed a preference for Haiti. The leaders of the respective parties were commissioned to go to these various countries to do what they could

in carrying out their schemes. Holly went to Haiti and took up with the Minister of the Interior the question of admitting Negroes from the United States.

Before any results from these deliberations could be obtained, there appeared evidence of considerable interest in emigration. This was especially true of Illinois and Indiana, from which commissioners had been sent out to spy the land. This is evidenced, too, by the sentiment expressed by delegates attending the Cleveland Convention in 1854. **Interest in the West.** The next colonization con-

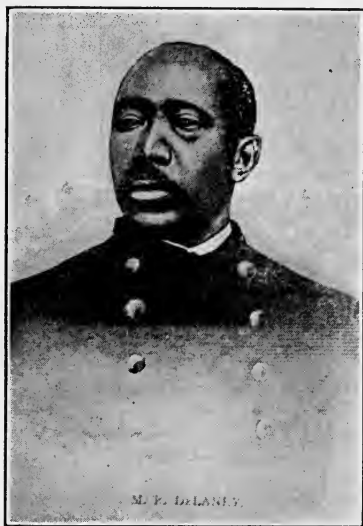

MARTIN R. DELANEY, an author, physician, and leader before the Civil War

vention was held at Chatham, Canada West, in 1856. One of the important features of this meeting was the hearing of the report of Holly, who had gone to Haiti the previous year. From this same meeting Martin R. Delaney proceeded on his mission to the Niger Valley in Africa. There he concluded a treaty with eight African kings, offering inducements to Negroes to emigrate. In the meantime, James Redpath had gone to Haiti and accomplished some things that Holly failed to achieve. He was appointed Haitian Commissioner of Emigration in the United States, with Holly as his coworker. They succeeded in sending to Haiti as many as two thousand emigrants, the first sailing in 1861; but owing to their unpreparedness and the unfavorable climate, not more than one-third of them remained.

CHAPTER XI

ABOLITION

BECAUSE of the hard lot of the Negro, the opposition to slavery was fanned into such a flame during the thirties that the movement could no longer be properly designated anti-slavery. It was abolition, an effort to effect the immediate emancipation of the slaves, since to hold them in bondage was contrary to the law of God.¹ The most formidable leader of this radical reform was William Lloyd Garrison, who came forward with the argument that slavery was contrary to the natural rights of humanity, had bad effects upon the southern whites, and handicapped the whole Union, not only as an evil but as a sin.² Coming at a time when the world was again stirred by the agitation for the rights of man in Europe, this radical movement secured much more attention than it would have otherwise received. Men were then concerned with the better treatment of paupers, convicts, and the insane. They were directing their attention to special education for dependents and delinquents. There was an increasing interest in temperance, the rights of the laboring man then .

¹ William McDonald, *Select Statutes*, 385-437; A. B. Hart, *Slavery and Abolition*, 152-295; his *History Told by Contemporaries*, IV, 24, 42, 72-143; William Jay, *Miscellaneous Writings*; W. P. and F. J. Garrison, *William Lloyd Garrison, passim*; F. L. Olmsted, *Back Country*; F. A. Kemble, *Georgian Plantation, passim*; D. R. Goodloe, *Southern Platform*; H. von Holst, *History of the United States*, III; J. B. McMaster, *History of the United States*, VI, 567-571.

² See Appendix for extract from the *Liberator*.

claimed all but national attention, and woman suffrage came forward as a promising reform of the time. It was helpful to the Garrisonian movement, too, that new fields of opportunities were then opening in the North and West. With the growth of foreign trade, there arose a need for that sort of labor which the unskilled slave could not furnish. Appearing then at this time, Garrison could more easily arouse the people of the whole country as to the inevitable doom of a slaveholding nation.

Basing his fight, therefore, on moral grounds and contending that slavery could not be defended, he evoked the censure of the proslavery people, who became just as radical and fiery in the defense of the institution as he was in attacking it.

Slavery a moral evil. After having been forced out of Baltimore because of his antislavery utterances he went to Boston and founded the *Liberator*.³ The result was such a clash of words and a multitude of threats that it seemed likely that the South



WM. LLOYD GARRISON

might secede. This feeling was further intensified by a number of uprisings among Negroes during the first three decades of the nineteenth century, culminating in Nat Turner's insurrection in Virginia in 1831. But intense as this excitement became, Garrison could not be hushed. His very words will give a better idea as to the earnestness of his purpose. He said, "I shall strenuously con-

³ Almost any work on abolition deals largely with the career of William Lloyd Garrison, but the standard biography of the reformer is Wendell Phillips Garrison and Francis Jackson Garrison's *William Lloyd Garrison*, the story of his life told by his children.

tend for the immediate enfranchisement of our slave population. I will be as uncompromising as justice on the subject—I am not wrong, I will not equivocate, I will not retreat a single inch and *I will be heard.*”

The *Liberator*, of course, could not have at that time a very wide circulation, but it did find sufficient friends interested in the cause to maintain the publication. Garrison showed that he was by nature a jour- Garrison asnalist whose opportunity was unexcelled. He a journalist. always succeeded in making his newspaper lively by conducting editorial combats and infuriating his antagonists. His work was made more effective by his fire-eating oratory. “No banderillero,” says A. B. Hart, “ever more skillfully planted his darts in the flanks of an enraged bull!” He had no mercy on slaveholders, accepted no excuses for their institution and did not distinguish between those of the patriarchial order and those exploiting the slaves. Intensely interested in his cause, he breathed the very earnestness of his truths in everything that he said. Returning from one of his meetings he remarked: “The whole town has known of freedom. Every tongue is in motion. If an earthquake had occurred it could not have excited more consternation.”

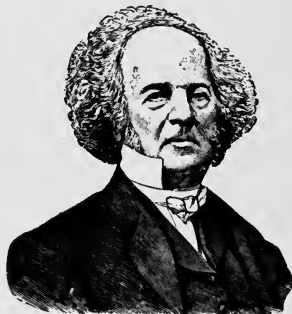

LEWIS TAPPAN

To promote the cause effectively national organizations soon seemed a necessity. On October 29, 1833, therefore, there was issued by Arthur Tappan, Joshua Leavitt, and Elizur Wright, officers of the New York Antislavery Society, a call for antislavery representatives to meet in Philadelphia on the fourth of the following December. Sixty

delegates appeared and adopted a constitution,⁴ together with a declaration of sentiments, the original draft of which was drawn by William Lloyd Garrison. This organization for some years thereafter served as a clearing house for the expression of abolition sentiment, but because of differ-

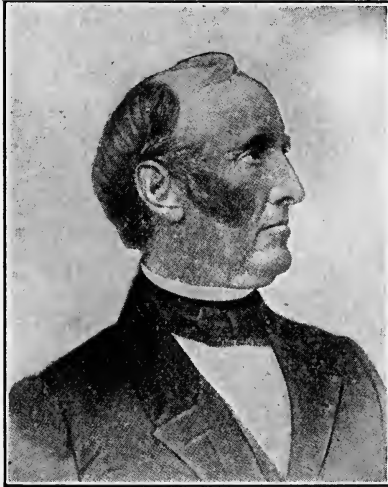

WENDELL PHILLIPS

ences arising in the ranks thereafter, it had to share the field with an American and Foreign Antislavery Society meeting the requirements of those who could not conform with the methods and procedure of the American Antislavery Society.

Along with Garrison worked a number of radicals.⁵ There stood Wendell Phillips, a well made, remarkably graceful person of expressive countenance with a sort

of fascination in the soft gaze of his eyes, attracting attention wherever his beautifully musical voice was raised in

behalf of the slave. Had he been interested in some other element than the Negro, he would to-day be known to history as the superior of Pitt, Sheridan, or Burke. Although having bright prospects for a future as a popular public man, he early chose the part of coöperating with the much-hated abolitionists and ever

⁴ See Appendix for a copy of this constitution.

⁵ The efforts of these various workers are sketched in William Wells Brown's *Rising Son*, Ch. on Abolitionists; A. B. Hart's *Slavery and Abolition*, pp. 152-323; and W. P. Garrison and F. J. Garrison's *William Lloyd Garrison*.

Abolition

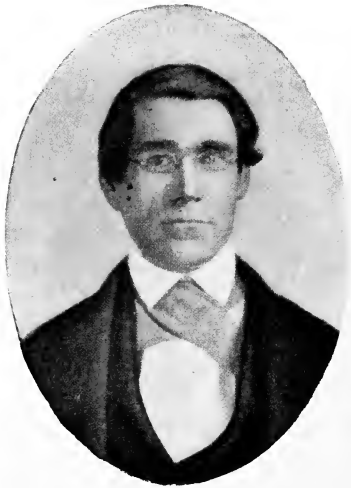

ANTISLAVERY APOSTLES

ABBY KELLY FOSTER
LUCY STONE

STEPHEN S. FOSTER
GEORGE THOMPSON

thereafter wielded his eloquence in behalf of freedom and democracy.

A number of others aligned themselves with these champions of liberty. There was the brilliant scholar, Edmund Quincy, not so eloquent as Wendell Phillips, but none the less staunch in his advocacy of freedom. **Other co-workers.** There appeared also Francis Jackson, one of the first to stand by Garrison when the mob broke up his antislavery meeting in 1835. Maria Weston Chapman, another of this group, contributed much to the support of abolition by raising funds through the Antislavery Bazaar. Charles F. Hovey, the abolition merchant, gave large sums to support the cause. Eliza Lee Follen, a poet, sang of liberty and freedom. Sydney Howard Gay, the polished writer, boldly advocated instant emancipation. William J. Bowditch, a scholarly lawyer, used his talent to promote freedom. With sketches of intelligent Negroes Lydia Maria Child gave the race a hearing in circles formerly closed. Thomas Garrett kept the same fires burning in proslavery Delaware.

Prominent in this group was Samuel May, Jr., who for some years served efficiently as the general agent of the Society. When the cause of abolition seemed helpless, **Samuel May.** abandoned a church paying him a lucrative salary that he might help to save the work, and, says an historian, "To his perseverance, industry, gentlemanly manners and good sense the Society owed much of its success." Although simple and plain, he was an earnest speaker, showing such depth of thought that persons concerned with universal freedom learned to wait upon his words.

Samuel J. May, another abolitionist of almost the same name, was a philanthropist by nature. He sympathized with Garrison and assisted in the organization of the Society, being one of the signers of Garrison's "Declaration of Sentiments," presenting the principles upon which the

right of man to freedom is based and the call to all men to promote emancipation. May was one of the few who stood by Prudence Crandall in Canterbury, Connecticut, when she was by special enactment imprisoned because she dared to admit girls of color to her academy. He made his home

a place of refuge for fugitive slaves and opened his church to any intelligent lecturer who carried the message of freedom.

To promote this cause a corps of workers were required to serve as lecturers in the field. These had to do the most difficult work of win- **Antislavery**
ning the pub- **lecturers.**

lic to the movement. Hissed and jeered by proslavery sympathizers hurling upon them rotten eggs, sticks and stones, these agents unselfishly performed their task. Some neither asked nor received any compensation; others gave their



PRUDENCE CRANDALL

time and paid their own expenses. Among these lecturers who thus toiled was Abby Kelly Foster, the Joan of Arc of the antislavery movement. She was a slim but well proportioned and fine-looking woman of **Abby Kelly**
bright eyes, clear voice, drawing such life-like **Foster.**
pictures of the black woman in chains that one could not hear her without shedding tears. A logical, forceful speaker, successful with irony or argument and quick at repartee, Mrs. Foster usually convinced her audience or

discomfited her opponents. Along with Mrs. Foster went her faithful husband, Stephen S. Foster. He was one of those who did not despise the cause in its day of small things. He labored incessantly to promote the work, and because of his unusual zeal and honest method of "hewing to the line and the plummet" he became the most unpopular of the antislavery agents. Yet he always told the truth, did not overstate a question and usually proved his point.

There were others scarcely less active. The eloquent Charles C. Burleigh, one of the most successful debaters championing the cause of the slave, would have been almost as effective as Wendell Phillips had he not spoken rather fast. Burleigh rendered the cause much aid as a lecturer and the editor

of *The Pennsylvania Freeman*. Lucy Stone, an unprepossessing but pleasant woman of medium stature, round face, sparkling eyes, and with her hair cut short, became with her abundance of enthusiasm one of the most active abolitionists, moving the people by forceful arguments and pathetic appeals. Susan B. Anthony, later known to greater fame as an advocate of woman suffrage, stood out as an eloquent abolition speaker with few equals. Andrew T. Foss left his pulpit to devote

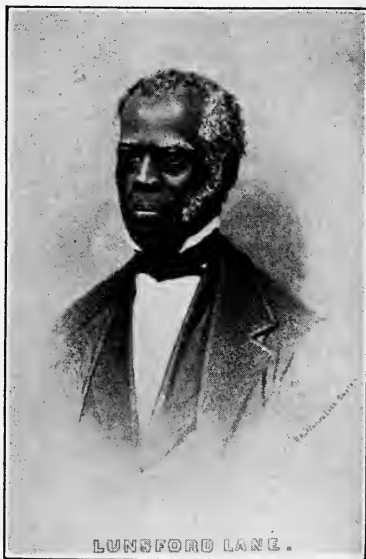

LUNSFORD LANE, a native of North Carolina, who lectured in the North against slavery

all of his time to abolition. Sallie Hollie put so much Scripture and prayer into her appeals that few refused her a hearing. Oliver Johnson, the ready debater, accomplished writer and eloquent speaker, not only served on the platform but at times edited *The Herald of Freedom*, *The Antislavery Standard*, and *The Antislavery Bugle*. Henry C. Wright devoted the best years of his life to the cause. The Grimké sisters, daughters of a prominent citizen in Charleston, South Carolina, left the South that they might without interruption bear witness against slavery. Charles B. Stebbins, the acute thinker and able speaker, also decidedly aided the movement. Nathaniel P. Rogers, with his penetrating mind, dealt hard blows at slavery through *The Herald of Freedom*. William Goodell and Theodore F. Weld exposed the institution by publishing works on slavery. James Miller McKim, a promoter



LUCRETIA MOTT

of the Underground Railroad, was once the moving spirit of the Antislavery Society in Pennsylvania, where he was ably assisted by the untiring and eloquent Mary Grew.

Abolition was put on its feet in Pennsylvania, however, by Lucretia Mott.⁶ She was a woman of faultless head, thoughtful countenance, beaming eyes, and full voice, hesitant in speech at the beginning and then growing easily eloquent. Assisted by a husband giving his means and time to the work, Lucretia Mott stirred up the people. Abolitionist to the manner born, she endeavored to effect a proscription of the products of slave labor by discouraging the use of clothing and foods produced in

⁶ A. D. Hallowell, *James and Lucretia Mott; Life and Letters*.

the South. She carried with her, to sweeten her tea, sugar produced by free labor rather than run the risk of having to use that produced by slaves. A woman of culture and conversant with the conditions obtaining among the slaves, she attracted the attention of the indifferent observer and impressed upon his mind a new thought of the man far down. In her attack on slavery no abolitionist was more fearless, none more successful in presenting the cause.

Yet eloquent as was the appeal of white men in behalf of the slave the aboli-

Charles L. Remond. tionists soon realized that

the Negro pleading his own cause could wield effective blows against slavery. The first Negro to be called to this service was Charles L. Remond, who, until the rise of Frederick Douglass, was probably the ablest repre-

sentative of the Negro race. He was small of stature, of spare build, neat and genteel in appearance. He possessed a pleasing voice and early attained rank as an acceptable speaker. A free-born Negro himself, he felt more keenly the prejudice against his class than he did the persecution of the slaves, and confined his speeches largely to the desired change in the attitude of the whites toward the people of color. So proud was he of being a free man of color that he often boasted that he had not a drop of slave blood in his veins. He contributed to newspapers and magazines fre-

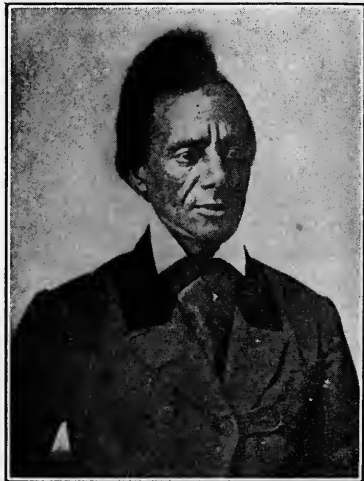

CHARLES LENOX REMOND

quent letters and articles exhibiting clearness, force, and depth. It was said that no other man could put more real meaning in fewer words. Remond, thus equipped for his task, was employed by the Antislavery Society as a lecturer for about thirty years. In 1840 he attended the Convention of the World Antislavery Society in England, remaining abroad two years to lecture in Great Britain and Ireland, where he made a very favorable impression.

Other Negroes were also successful. William Wells Brown thus served the Society from 1843 to 1849, and also Lunsford Lane of North Carolina, some years later. Sojourner Truth, by her mysterious communings, seemed to acquire miraculous power as a co-worker of the abolitionists to stir audiences with her heavy voice, quaint language and homely illustrations. But another Negro thus employed was more successful. He was not merely a Negro asking for the rights of freemen, but

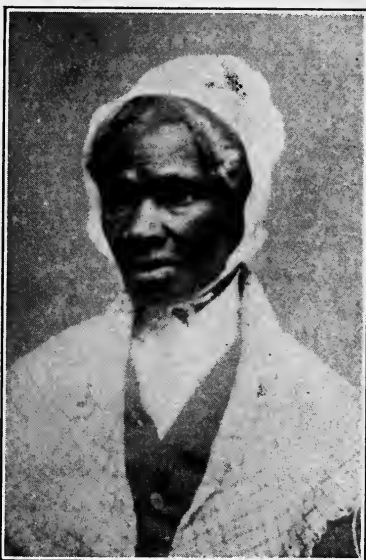

SOJOURNER TRUTH

the developed emancipated slave going through the country as the embodiment of what the slave was and what he might become. He was then not only the thing discussed by the abolitionists, but the union of the lecturer and his subject. Endowed, too, with philosophical insight and broader intellect than most men, he

**Frederick
Douglass.**

soon developed an effective oratory with which nature had enriched his gifts. This man was Frederick Douglass.⁷

Unlike Remond, Douglass had much originality and unadorned eloquence rather than a fine flow of language.

When the country, therefore, had heard Frederick Douglass, Remond became a second-rate man. This

soured the spirit of the latter, who fell a victim of speaking disparagingly of his coworker. But Remond was not the only anti-

The success of Douglass. slavery orator to pale into insignificance on the approach of the "eloquent fugitive" from slavery in Maryland; for the people preferred to hear Douglass. And well might they desire to see and hear this man. He was tall and well

made, with a fully-developed

forehead. He was dignified in appearance, polished in his language, and gentlemanly in his manner. A contemporary said: "He is a man of lofty reason, natural and without pretension; always master of himself; brilliant in the art of exposing and abstracting." Another said: "In his very look, his gesture, his whole manner, there is so much of genuine, earnest eloquence, that they have no time for reflection. Now you are reminded of one rushing down some

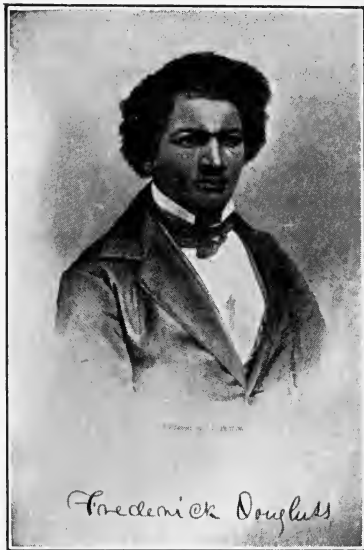

FREDERICK DOUGLASS

⁷ See Frederick Douglass' *Narrative of the Life of Frederick Douglass, as an American Slave*, and his *Life and Times of Frederick Douglass from 1817 to 1882*.

fearful steep, bidding you follow; now on some delightful stream, still beckoning you onward. In either case, no matter what your prepossessions or oppositions, you for the moment, at least, forget the justness or unjustness of the cause, and obey the summons, and loath, *if at all*, you return to your former post.”

CHAPTER XII

FURTHER PROTEST

IN the western part of the country, too, abolition was for economic reasons gradually gaining ground. There had always been much antislavery sentiment in the mountains of North Carolina, Tennessee, Kentucky and West Virginia.

Abolition in the West. When the intolerable condition of the Negroes in the South made it impossible for the persons

in that part of the country to do for the Negroes what they desired, they moved into the Northwest Territory where they could carry out their plans for the uplift of the blacks.

Accordingly, in these mountains there arose a number of antislavery societies. Among the persons operating as the nucleus around which this sentiment developed were such men as Benjamin Lundy in Tennessee, James G. Birney in Kentucky, and Daniel R. Goodloe in North Carolina. Other ideas, too, tended to influence the youth, as it happened in the case of the students in Maryville College in Tennessee, more than half of whom had become antislavery by the year 1841, and in that of Berea College in Kentucky, which developed from a group of students influenced largely by

In Kentucky. Cassius M. Clay, the antislavery editor, and John G. Fee,¹ the abolition orator who founded that institution.

As this sentiment tended to spread in the proportion that the antislavery leaders of the western slave States were forced to go North, there was made possible a better chance for abolition in centers where it had been considered danger-

¹ John G. Fee's *Antislavery Manual*.

Further Protest

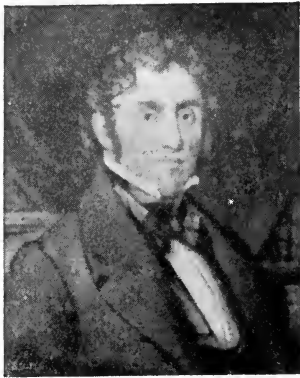

SOUTHERN ABOLITIONISTS

BENJAMIN LUNDY

DANIEL R. GOODLOE

JOHN G. FEE

JAMES G. BIRNEY

CASSIUS M. CLAY

ous. In Lane Theological Seminary in Cincinnati, the ardent discussion of slavery led to a sort of upheaval, resulting in a division of the students. Theodore **Lane Seminary.** F. Weld, one of this group, actually espoused the cause of Garrison and undertook to translate into action his theories of Negro uplift by actually teaching colored children. As Lane Theological Seminary was then attended by a number of southern students, a separation of those who had thus become divided was necessary. When the trustees tried to prevent further discussion of slavery four-fifths of the students withdrew. Fifty-four asserted their right to a freedom of discussion of this important topic, and under leaders like Asa Mahan and John Morgan retired to the Western Reserve and established Oberlin College.²

In that same section of Ohio, however, antislavery societies had already flourished under the leadership of Samuel Crothers, John Rankin, and Elizur Wright, later a **The Western Reserve.** professor in the Western Reserve College. These antislavery centers, too, were further strengthened by the coming of James G. Birney³ from Kentucky, from which he had been driven because of his antislavery utterances. He first established in Cincinnati, Ohio, the *Philanthropist*, a newspaper which wielded great influence in preparing the minds of the people of this country for a fair discussion of slavery, although his life was several times endangered and his press was twice broken up and destroyed.

Another group of abolitionists deserve honorable mention. These were reformers of a milder sort, who could neither tolerate radicalism nor approve the methods of some of the

² This is narrated in the *First Annual Report of the American Anti-Slavery Society*.

³ James G. Birney, *The American Churches, the Bulwarks of American Slavery*; and William Birney, *James G. Birney and His Times*.

less ardent antislavery group. Among those taking this position was Dr. William Ellery Channing, a Unitarian minister of much fame in Boston and New-
port. His appeal was to the intellect rather than to the emotion. In presenting his case he wrote essays on slavery, making a forceful argument as to evil of the institution but suggesting some remedy other than instant abolition. Along with Channing may be mentioned scores of writers like Fredrika Bremer, Frances Kemble, Henry Wadsworth Longfellow, James Russell Lowell, and John G. Whittier.

**William E.
Channing.**

There were abolitionists who in addition to appearing on the platform otherwise rendered the cause valuable service. Among these were Arthur and Lewis Tappan, successful merchants of New York, who had for years supported the cause of coloni-



GERRIT SMITH

zation but, seeing that it did not reach the root of the evil, abandoned that movement to promote abolition. More prominent than these was Gerrit Smith of Peterboro, New York, son of an ex-slaveholder. He too, had at first restricted his efforts at uplifting the Negroes to what could be effected through the colonization society. Becoming more interested in the behalf of the Negroes and also developing in his mind anti-land monopolist tendencies, he devised the scheme of improving their condition by

transplanting them from the city to small farms in the country. He therefore addressed a letter to Charles B. Ray, Dr. J. McCune Smith and Theodore S. Wright, prominent Negroes of New York City, asking them to designate a number of Negroes whom he might thus colonize on his lands in certain counties in southeastern New York. This list was accordingly given and the enterprise undertaken, but because of the infelicity of the soil and the lack of initiative on the part of the Negroes, it failed.

The more intense the abolition agitation grew, however, the more sectional the movement became. Backward as the institution of slavery seemed, the South became more and more attached to it and would not countenance any attack on it. Not only was the old-time abolitionist in danger there after 1840, but the ordinary observer who suggested moral suasion held his social position by precarious tenure. Cassius M. Clay was driven out of Lexington, Kentucky, by proslavery citizens who could not tolerate the antislavery sentiments expressed in his *The True American*. Upon receiving some copies of the *Emancipator*, which he loaned to white friends while in Washington, Dr. Reuben Crandall of New York was arrested and imprisoned on the charge of inciting a riot among the slaves but, after waiting trial eight months in jail, he was declared not guilty. Not knowing the temper of the South, an English traveling bookseller was whipped and driven out of Petersburg, Virginia, in 1832, because he dared to say at the time of the Nat Turner insurrection excitement that the blacks as men were entitled to their freedom and should be emancipated. Amos Dresser, a student of Lane Seminary and of Oberlin College, was whipped and expelled from the State of Tennessee because, while selling books in that State, he had a copy of the *Emancipator* wrapped around a Bible left in a Nashville hotel.

Abolition in the South, therefore, ceased to be openly

agitated. The radicalism of Garrison tended to solidify the South against the struggle for free institutions. His advice to Negroes to educate their children, to build up their own trades, aid the fugitives, and to qualify as voters, stirred up the South; for there it was believed that if both races were

**Abolition
quelled in
the South.**

free, one would have to be driven out by the other or exterminated. Southerners caused alarm by the false rumor that the abolitionists advocated the amalgamation of the races, although Jay did not think that white men would have to select black wives and John Rankin disclaimed any such desire for miscegenation, while Channing thought we have no right to resist it and it is not unnatural. Southerners were successful, too, in promoting their cause by raising the complaint of the circulation of incendiary publications portraying by pictures, cuts and drawings, the cruelties of slavery to acquaint the bondmen with the awful state to which they were reduced. These publications, however, because of the crass ignorance in which most Negroes were kept, as a rule, never reached them. With the exception of a few like Samuel Green, a free Negro, in Maryland, who was sent to the Maryland penitentiary for having in his home a copy of *Uncle Tom's Cabin*, there were not many instances of Negroes making use of these publications.

Moderate abolitionists in the South thereafter either abandoned their plan or coöperated with the colonizationists in seeking an opportunity for the national development of the Negro abroad. Radical abolitionists either left for the North or remained in the South to entice Negroes to escape from their masters by way of the Underground Railroad. As this was a rather dangerous risk in the South where such was heavily penalized, many of these persons almost suffered martyrdom in behalf of the fugitives. Jonathan Walker was branded

**Martyrdom of
abolitionists.**

with a hot iron for aiding the escape of a slave. In 1841 Thompson, Burr and Burke, abolitionists from Illinois, were sentenced to serve a term in the Missouri penitentiary for persuading slaves to escape from the town of Palmyra. In 1844 L. W. Paine, a Rhode Island machinist working in Georgia, was thus imprisoned six years for the same offense. John L. Brown was, in 1846, condemned to be hanged for aiding fugitives, but the sentence was commuted to a whipping. Daniel Drayton, captain of a vessel upon which he permitted seventy-seven slaves to escape from their masters in the District of Columbia, lost his health while he was being almost starved there in confinement in an unsanitary prison cell. Another of these sympathizers, Delia Webster, a young lady from Vermont, teaching in Kentucky to find an opportunity for thus aiding fugitives, was sent to the penitentiary for two years. Calvin N. Fairbank, her accomplice, was sentenced to serve a term of fifteen years in the State prison. When pardoned by Governor John J. Crittenden, he immediately resumed his work in defiance of law and public opinion, and in 1852 was imprisoned the second time for fifteen years. He was not released until 1864, when the sympathetic Acting Governor Richard T. Jacobs, taking advantage of the absence of Governor Bramlette, pardoned Fairbank. Charles T. Torrey, a graduate of Yale and Andover Theological Seminary, went to Annapolis to report a slaveholders' convention, for which he was arrested and required to give bond for his good behavior. Some years later, upon being charged with having assisted a slave in escaping from his master, Torrey was convicted and imprisoned in a Maryland penitentiary, in which he died.

Exactly what the abolitionists accomplished is difficult to estimate. Some are of the opinion that the radicals did the cause of emancipation more harm than good. Few white men of that day felt that the slaves could be in-

Further Protest

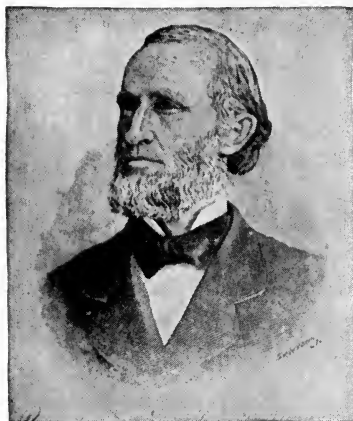

WHITE MARTYRS IN THE CAUSE OF ABOLITION
DANIEL DRAYTON
CALVIN FAIRBANK

L. W. PAINE
CHARLES T. TORREY

stantly emancipated. Most advocates of freedom had thought of gradual methods, and the radical reformers who stirred up the whole country with the idea of immediate abolition set the conservatives against emancipation. The agitation itself, however, was hopeful. It showed that the country had developed a feeling of nationalism. A man living in Boston had begun to think that to some extent he was responsible for an evil obtaining in South Carolina. Leaders of thought were no longer content to leave it to the various States to decide for themselves whether or not an evil should be tolerated within their limits. Slavery had become so engrafted upon the country as to require national attention and national treatment. It resulted, therefore, in inciting a large number of antislavery people to greater activity and enabled the abolition societies to unify their efforts throughout the North by organizing and stimulating local bodies, all of which helped to make possible the destruction of slavery.

In the beginning their struggle was a hard one, but they had, after 1836, gained considerable ground. In the first place, the North did not take seriously the agitation for the abolition of slavery in a section closely connected with its financial and manufacturing centers. Others, who had no such interests, moreover, regarded the abolition agitation as a direct attack on the Union, in that the provision for the continuance of slavery in the Constitution was attacked; and citizens in Southern States, considering these attacks as intended to disturb the peace in their commonwealths, declared that it furnished sufficient ground for withdrawal from the Union. In several of the Northern States, therefore, legislation was proposed to penalize discussions "calculated to excite insurrection among the slaves," as an offense against the peace of the State. Some undertook to brand the efforts of the abolitionists as acts of sedition. As the abolitionists made good

their right of free speech, however, they were not hampered in the North by such laws.

As it was therefore necessary for the opponents of the abolitionists to express themselves in some other way, they resorted to mob violence. During the years from 1834 to 1836 about twenty-five or thirty efforts were made to break up abolition meetings. There was an anti-**Antislavery** abolition riot at Clinton Hall in New York in **riots.** 1833. Then followed a number of riots, culminating in the destruction of the property of the abolitionists in 1834, when the same sort of violence broke out in Utica, New York. When George Thompson, the experienced spokesman of the abolitionists in England, came to this country to further the cause, and had himself advertised to speak in Boston, the so-called friends of the Union organized a mob, but Thompson, having had notice as to what they hoped to do, failed to appear. William Lloyd Garrison, who had the courage to attend, found himself in the midst of a riotous crowd whom the mayor, despite his efforts, could not control. When the mayor made known his inability to control the mob, the crowd ran Garrison down, put a rope around his body and pulled him through the streets of Boston. "The man," said an observer, "walked with head erect, flashing eyes, like a martyr going to the stake, full of faith and manly hope." To save his life, the mayor sent Garrison to the Charles Street jail, where he was with some difficulty rescued from the mob.

In Pennsylvania, in which the large city of Philadelphia offered many reasons for close commercial attachment to the South, the cause of abolition had much opposition, despite the healthy antislavery sentiment among the Quakers. As the city of Philadelphia was being **Disorder in** rapidly filled up at this time with Germans **Pennsylvania.** and Scotch-Irish, who observed the prosperity of migrating freedmen with a covetous eye, these business men could by

a very little encouragement to the disorderly crowd bring about a riot, especially so when the city was very poorly policed. A mob disgraced the city in 1834 by beating up a number of Negroes and damaging fifty-four houses. It was somewhat difficult thereafter to find a place for abolition meetings. Negro churches closed their doors to these agitators, not because they could not appreciate the impetus the abolitionists gave the cause of freedom, but, knowing that any building in which an abolition meeting was held might be burned, the Negroes had to exercise precaution. To solve this problem, the abolitionists constructed a building of their own, known as Pennsylvania Hall, but when it was noised abroad that Garrison and other abolitionists had addressed a meeting there, on May 16, 1838, there was formed a mob which broke open the doors, set fire to the building, and prevented the authorities from extinguishing the flames. Pittsburgh had such an outbreak the following year.

In the western part of the United States, where the abolitionists were equally bold, the same sort of riotous condition obtained. In 1836 a mob, long since enraged because of the advocacy of abolition in the *Philanthropist*, edited by James G. Birney, destroyed his office and made desperate efforts to take his life. In Alton, Illinois, the place in which Elijah P. Lovejoy had sought refuge for his abolition efforts, when he had been forced to leave St. Louis for criticizing the burning of a Negro at the stake, the same violence broke out. After his press had been twice destroyed, his building was attacked by a mob on November 7, 1837. He returned their fire but, on waiting patiently on the outside for the exit of Lovejoy some time thereafter, the mob shot him dead. The jury appointed to inquire into the guilt of the offenders required only ten minutes to bring in a verdict of not guilty.

Instead of preventing the rise of abolition, as was

expected, these efforts rather tended to increase the sentiment in the North against slavery. In some of the State legislatures there began to appear a number of antislavery members, and very soon even in Congress. **Results of riots.**

John P. Hale first took a stand against slavery in the Senate. In 1838 there came to Congress the down-right abolitionist, Joshua R. Giddings of the Western Reserve.

William Slade of Vermont, an antislavery man, was sent to that body in 1840. There appeared, too, Thomas Morris, a United States Senator from Ohio, who rendered the cause much assistance.

The abolitionists then had the opportunity to gain national recognition as a body primarily interested in promoting the moral life and atmosphere of the country. But they were far apart in their method of procedure, and radical utterances denouncing the Constitution as a proslavery document, while others argued that it was antislavery, did their cause unusual harm.

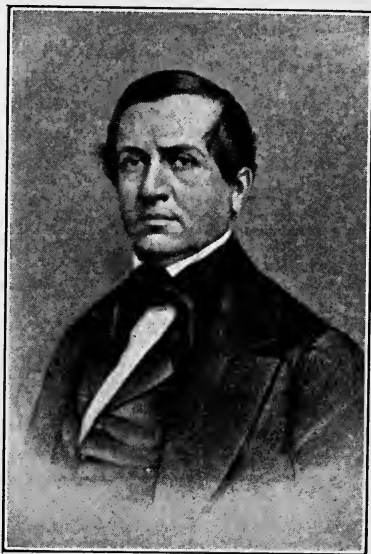

SENATOR JOHN P. HALE

Salmon P. Chase insisted that the Constitution is an anti-slavery document, making the institution a black forgery. Replying to the arguments of the proslavery element that slavery was maintained by the Federal Constitution, some others, although not advocates of instant abolition, insisted that a higher

**Radical
leaders
increased.**

law than the Constitution protested against the action of Congress on this point. According to the law of human nature "no greater crime against human beings can be committed than to make him a slave." While Garrison, in 1835, called God to witness that the abolitionists were not hostile to the Constitution⁴ of the United States, in 1843 he declared "that the compact which exists between the North and the South is a covenant with death and an agreement with Hell, involving both parties in atrocious criminality, and should be immediately annulled." There still remained milder abolitionists like William Jay and Channing, who disavowed the extreme theory. The cause of abolition, however, continued to suffer, for it had not only failed to interest a majority of the people in the North but had furnished sufficient radicalism upon which the pro-slavery spokesmen could stir up the country with threats of disunion, and terrorize the gradual emancipationists in the South.

⁴ See the appeal of a Southern matron in the Appendix.

CHAPTER XIII

SLAVERY AND THE CONSTITUTION

DURING these years, important constitutional questions grew out of the encroachment of slavery and its haughty pretension to national precedence. The abolitionists had, by 1830, become unusually aggressive and were organizing throughout the country to make a bold at- tack on the institution. They were then presenting to the State legislatures and Congress various petitions asking, among other things, for the abolition of slavery in the District of Columbia. These petitions at first were received and then refused favorable consideration. They had in the course of time been more easily disposed of by merely being referred to a committee which permitted them to die a natural death. Upon the occasion, however, of a petition of John Quincy Adams, long known as the only spokesman in behalf of free speech in Congress, the House voted to refuse such petitioners a hearing. This implied that a reasonable portion of the citizens of the United States were denied the right of petition guaranteed by the Constitution of the United States.¹ Adams contended that these petitions must be received, heard, and referred to a committee, but when he

¹ John W. Burgess, *Middle Period*, Chs. IV, X, XI, XIII, XVIII, XX; J. B. McMaster, *History of the United States*, VIII, pp. 473-521, 438-512; James Schouler, *History of the United States*, V, 389-433; T. C. Smith, *Parties and Slavery*, *passim*; James F. Rhodes, *History of the United States*, III, IV, V, VI; William MacDonald, *Select Statutes* I, 343, 365-372, 385-390, 397-454; II, 35-38, 42-43, 113; A. B. Hart, *American History Told by Contemporaries*, III, 574-655; IV, 122-192.

insisted that there should be a report from the committee and a vote upon that report it looked too much like an insult from the antislavery party. He was, therefore, censured by the proslavery element in the House.²

It is well to keep in mind, however, that Adams was not an antislavery man. His career had shown proslavery tendencies.³ In the Senate, in 1807, when the prohibition of the slave trade was brought before that body, he voted against the measure. As a member of the mission negotiating the treaty with Great Britain,

**The record
of Adams.**

by which the War of 1812 was closed, he demanded compensation for slaves who had been carried away from their masters by the British Army. During his incumbency as Secretary of State he was unfriendly to the proposal of Great Britain for a slave trade treaty in the interest of the Africans, and as President he manifested no particular interest in the bond men. Throughout his struggle

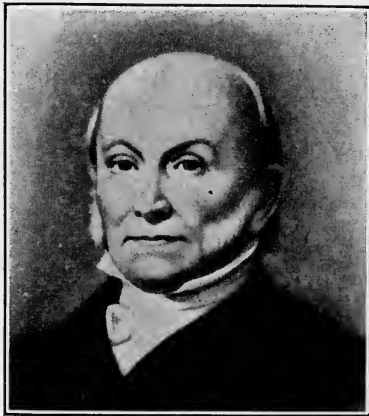

JOHN QUINCY ADAMS, the champion of free speech

for the right of petition in Congress, therefore, he was interested, not in the work of abolitionists but in defending the right of the people of his section to free speech.

When the House, in 1835, tabled an antislavery petition presented by John Quincy Adams, Henry A. Wise of Vir-

² John W. Burgess, *The Middle Period*; A. B. Hart, *Slavery and Abolition*; and Herman von Holst, *Constitutional and Political History of the United States*.

³ See the speech of John Quincy Adams quoted in the Appendix.

ginia took occasion to remark: "Sir, slavery interwoven with our very political institution is guaranteed by our Constitution, and its consequences must be borne by our northern brethren as resulting from our system of government, and they cannot attack the institution of slavery without attacking the institutions of the country, our safety and welfare." In December of that same year Slade of Vermont took occasion to remark that as a constitutional right an abolition petition should be printed, and that Congress had power to prohibit slavery in the District of Columbia. He believed, moreover, that the progress of abolition must be necessary to preserve the balance of the situation or, rather, to restore it. When a few days later two other such petitions were presented by Morris of Ohio and Buchanan of Pennsylvania, John C. Calhoun declared such a memorial "a foul slander on nearly one-half of the States of the Union," and urged "that a stop be put to that agitation which had prevailed in so large a section of the country and which, unless checked, would endanger the extension of the Union." Congress did not grant the desire of John C. Calhoun, but did vote to reject the prayer of the petition.

Southern members immediately thereafter secured a special "gag rule" that all petitions, memorials, resolutions, propositions or papers relating in any way or to any extent whatever to the subject of slavery or the "Gag Rule." abolition of slavery should without being either printed or referred be laid upon the table and that no further action whatever should be had thereon. The proslavery advocates had taken the advanced position that Congress could not legislate on slavery in the District of Columbia and that the wishes of the slave States bordering on the District of Columbia took precedence over the power of Congress to legislate for the District, although the Constitution provides that Congress shall make no law abridging the freedom of

speech or the rights of the people peaceably to assemble or to petition the government for the redress of grievances. Adams, therefore, held the resolution to be a direct violation of the Constitution of the United States and the rules of the House and of the rights of his constituents.

A new stage in the discussion of the right of petition in Congress was reached when, in 1837, there were presented resolutions from Vermont legislature praying that **A petition from a State.** slavery be abolished in the District of Columbia. As in accordance with the southern idea of State rights, no State could be questioned in presenting any petition to Congress, although citizens might be restrained therefrom, Rhett of South Carolina summoned to his support his southern coworkers to devise a plan for peaceably dissolving the Union. They finally agreed, however, to undertake the enactment of a law providing for a more successful "gag rule," which declared it "the solemn duty of the government to resist all attempts by one portion to use it as an instrument to attack the democratic institutions of another."

At this time Henry Clay and Daniel Webster, two of the weakest men in this country, were dodging the slavery question, although they saw the encroachment of the slave power upon the rights guaranteed the individual in the **Webster and Clay.** Constitution. Henry Clay, who declared that he was not a friend of slavery, preferring rather freedom for all men, nevertheless considered the petitions for the abolition of slavery "a great practical inconvenience and annoyance," from which he hoped the people in the North would desist. In 1830 Daniel Webster considered domestic slavery one of the greatest evils, both moral and political. In 1836 he felt that it was the duty of Congress to take care that the authority of this government was not brought to bear upon slavery by any indirect interference. He later announced that as to slavery he

would do nothing to favor or encourage its further extension. Yet with regard to abolition he felt that it had taken such strong hold on the consciences of men that, if it were coerced into silence, he knew nothing even in the Constitution or in the Union itself which would not be endangered by the explosion which might follow. Hoping to become president, he later tended to become neutral, and bartered

his birthright by an unsuccessful attempt to swallow the Fugitive Slave Law of 1850.

Growing bolder from year to year, the South during this period finally became **Calhoun, the proslavery leader.**

solidly organized under the leadership of John C. Calhoun, who had departed from his early position of nationalism to defend the institution of slavery. In 1836 he boldly declared that "Congress has no legitimate jurisdiction over

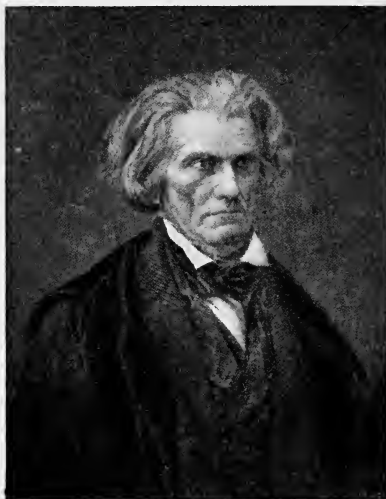

JOHN C. CALHOUN

the subject of slavery either in the District of Columbia or elsewhere."⁴ He believed that the abolitionists had no right to discuss slavery at all, that Congress should pass affirmative laws for the protection of slaveholders against abolition by mail and that the Northern States should be prohibited from engaging in the agitation. He insisted that "the conflicting elements would burst the Union asunder, powerful as are the links that hold it to-

⁴ See Appendix for J. R. Giddings's attack on this policy.

gether. Abolition and the Union cannot coexist; come what will, should it cost every drop of blood and every cent of property, we must defend ourselves.''

As the State of Texas, developed under direction of pro-slavery men led by Samuel Austin and Samuel Houston, became an independent slaveholding section desiring annexation to the Union, Calhoun found for the South a safety valve in championing the desirable policy of expansion. This extension of our territory

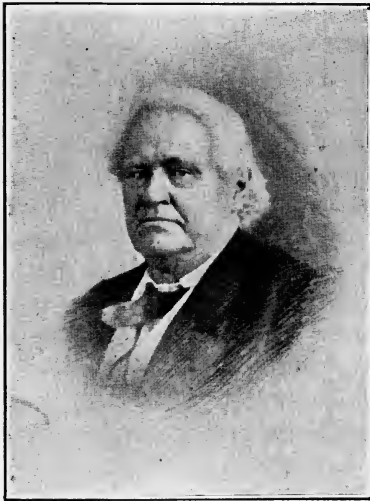

JOSHUA R. GIDDINGS

could not be easily defeated, although the purpose was to secure slave territory. Joshua R. Giddings, the first militant abolition member of Congress, however, showed in a speech attacking slavery, in 1841, exactly how the admission of Texas would increase the power of the South and effect the economic history of the whole country.⁵

Many constitutional difficulties were encountered after some of the States had abolished slavery. The

South continued to have trouble with fugitives escaping from its ports. It was always easy, moreover, for a few slaves to arrange with the Negro cooks and stewards on vessels to conceal them as cargo and deliver them to some agent of the Underground Railroad on arriving in the North. In 1837 the schooner *Susan*, sailing from Georgia, permitted a Negro stowaway to escape on

The return of fugitives.

⁵ See Giddings's speech in the Appendix.

Slavery and the Constitution

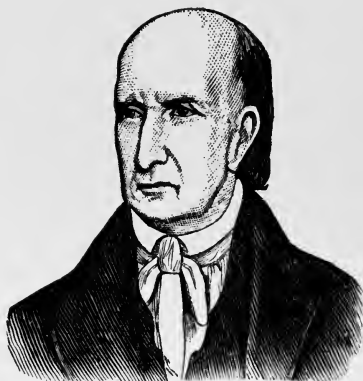
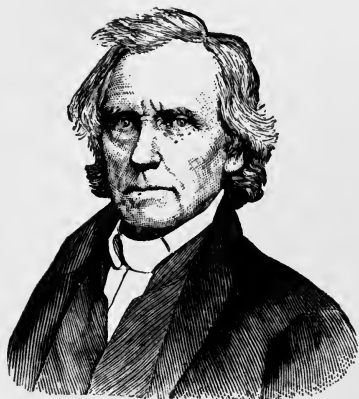

FRIENDS OF THE FUGITIVES

JOHN NEEDLES
GRACE ANNE LEWIS

ABIGAIL GOODWIN
DANIEL GIBBONS

reaching a port in Maine. The State of Georgia preferred charges against the officers of the ship and undertook to take them into custody, but the Governor of Maine refused to honor the requisition on the grounds that they had left Georgia before they were charged with the crime. Three

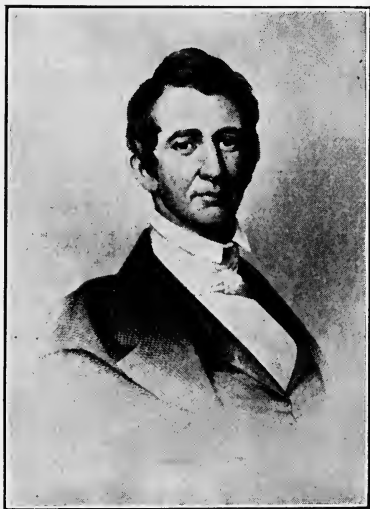

WILLIAM H. SEWARD

sailors coming into New York with the slave they helped to escape from Norfolk in 1839, were similarly protected by Governor William H. Seward, who despised the institution of slavery. This caused a prolonged controversy between the chief executives of the two States and the expression of much bitter feeling on both sides. Virginia finally passed a law requiring the inspection of all vessels bound for New York. Mississippi, taking up her cause, proposed "to unite with

other States in any measure of resistance or redress."

Because of the disturbances resulting from the Negro insurrection in 1822, South Carolina passed certain "Negro Seamen Acts" requiring all Negroes on vessels to go to jail

**Seamen
Acts.**

on arriving in port and to remain there until their vessels set sail again. These acts were earnestly protested against by Northern States and by England, all of which had constant commercial intercourse with South Carolina. The measures were relaxed with reference to England, but with respect to the Northern States they continued as law. Thinking that it would be advisable

to make a test case of this legislation, antislavery members of the Massachusetts legislature sent Samuel Hoar to intercede in behalf of a Negro thus deprived of his rights in that State. Upon arrival Hoar was notified that his life was in danger for the reason that he was "an agent coming in not as a citizen of the United States but as an emissary of a foreign government hostile to the domestic institutions and with the sole purpose of subverting its internal policy."

The South undertook also to indict as criminals against the laws of the States persons who, although they did not come within the limits of the States, had by way of mail or message incited insurrection or aided slaves to escape from their masters. **Attacks on slavery.** William Lago, a free Negro, was thus indicted in Kentucky. The Supreme Court decided that the governor of the State had a moral right to surrender Lago, but that the Federal Government had no power to compel him to do so. Joseph P. Mahan, a Methodist minister of Brown County, Ohio, was indicted by a grand jury of Kentucky for having aided the escape of certain slaves. Upon receiving a requisition from the Governor of Kentucky, the Governor of Ohio issued a warrant for the arrest of the minister. Not long after, however, the Governor of Ohio became convinced that the warrant had been issued without authority because Mahan had never been in Kentucky. The grand jury of Tuscaloosa County thus indicted R. G. Williams of New York in 1835, and the chief executive called upon Governor Marcy of New York to surrender him. The requisition was refused for the reason that Marcy could not see how a man could be guilty of a crime in Alabama when he had never been there. Rewards were offered for abolitionists like Arthur Tappan, and the State of Georgia appropriated \$5,000 as a reward for William Lloyd Garrison, the editor of the *Liberator*.

This same assumption of authority in the defense of

The Negro In Our History



PROMOTERS OF THE UNDERGROUND RAILROAD

WILLIAM WRIGHT

E. F. PENNYPACKER

J. M. MCKIM

SAMUEL RHOADS

JOHN HEMAN

WM. H. FURNISS

JOHN HENRY HILL

BARTHOLOMEW FUSSELL

slavery extended also to the search of the mails for incendiary matter sent by the abolitionists to slaves and their sympathizers in the South. Because of the annoyance from which the South had suffered therefrom, Calhoun introduced, in 1836, a bill providing that mail matter other than letters touching the subject of slavery should not be delivered in any State prohibiting the circulation of such matter. Congress, however, could not pass such a law, since many States had not prohibited the circulation of such matter. The matter was settled by a general search of the mails throughout the South, just as is done today in the time of war.

There arose also the question as to what effect on the status of the slave would his removal to a free State have and if, according to the law of that State it worked his manumission, would he be free on his return to the slave State from which he went. In Massachusetts slavery was forbidden for any cause, whereas in Missouri and Louisiana it was held that a freedman voluntarily returning to his master reverted to slavery. Indiana gave the master the right of transit with his slaves in that State. In Pennsylvania, however, it was not allowed. When John H. Wheeler of North Carolina passed through that State on his way to New York, from which he was to proceed to Nicaragua, Passmore Williamson informed Jane Johnson, the attending servant, that she was free under the laws of that State, and the courts upheld that opinion.

During the darkest days of slavery when many of them escaped to the Northern States, however, in spite of sentiment to the contrary, masters hunted them down in the North, demanding of the local courts their return to slavery. The local courts often refused to carry out these mandates, and certain Northern States passed personal liberty laws to impede these efforts

**Searching
the mails.**

**Removal to
a free State.**

**Personal
Liberty Laws.**

by granting alleged fugitives a trial by jury. In Vermont and New York local officials were deprived of jurisdiction in such cases, and State attorneys were required to act as legal advisers for Negroes thus accused. Ohio, however, egged on by the mob cruelly treating free Negroes migrating from the South to that State, enacted in 1839 a Fugitive Slave Law more drastic than the Federal measure of 1793. Some excitement was caused in 1837, however, when a Kentucky slave, Matilda, who, without being asked any questions, entered the service of James G. Birney at Cincinnati, was claimed and surrendered as a fugitive. In 1840 John Van Zandt was, despite the appeal to the Supreme Court by such valuable counsellors as Salmon P. Chase and William H. Seward, fined \$1,200 because he rescued one of nine slaves who had escaped to the other side of the Ohio River.

1850 An epoch was reached in the execution of the Fugitive Slave Law, however, when Edward Prigg of Maryland undertook to return from Pennsylvania the fugitive Margaret Morgan. Because Prigg seized her without first instituting proceedings in the courts of the State he was arrested for violating the Pennsylvania statute against kidnapping. Upon appealing to the United States Supreme Court, however, the opinion was given that the owner had a right to recover the slave but that the act of 1793 could not be construed as making its execution an obligation of the State officials. Following this decision John Shaw of Boston refused not long thereafter to grant a writ of habeas corpus in accordance with the State personal liberty law to remove Latimer, a fugitive, from custody of the Federal authorities. There followed such a storm of protest, however, such an array of abolitionists against the authorities thus administering the law, that an observer of the trend of the times could easily see that feeling was running too high to calm

The Prigg Case.

The Latimer Case.

the people of the North who were then openly resisting the execution of Federal law. The southern people bore it as a grievance, therefore, that the enemies of their basic institution could by the application of personal liberty laws deprive them of their property. They urged, therefore, the enactment of a more stringent measure which eventually culminated in the passage of the Fugitive Slave Law of 1850.

CHAPTER XIV

THE IRREPRESSIBLE CONFLICT

SLAVERY became more troublesome for the United States at home when it involved the country in entanglements abroad. The British Government gradually emancipated its slaves in the colonies after 1833, and there was a tendency on the part of slaves and their sympathizers to seek refuge in those parts when carried on the high seas. For years very little effort had been made to stop the numerous violations of the slave trade, despite the fact that European governments had repeatedly called upon the United States to unite with them to abolish this traffic in men. When the ship *Comet*, in 1831, carrying slaves, and bound for the United States, was wrecked at the Bahamas, they were brought ashore and set free on the ground that the British Government did not recognize slavery on the high seas. Similar instances occurred in the case of the *Encomium* in 1835, and the *Enterprise* and the *Hermosa* in 1840. The United States Government promptly demanded an indemnity, contending that the accidental presence of the vessels in British waters did not interfere with the relation of master and slave; but, doubtless for the reason that emancipation was not at that time completed in the West Indies, Great Britain granted the United States, in 1840, an indemnity of \$115,000 for the slaves of the *Comet* and *Encomium*, but nothing was granted for the others.

The only consolation our government received was to declare it a violation of international law for which no redress could be obtained.

There took place, moreover, a number of mutinies of slaves on the high seas, which, the proslavery element believed, required intervention on the part of the United States. One of the most significant of these **L'Amistad** cases was that of the *Amistad*. There were on board the schooner fifty-four Negroes who were being carried coastwise from Havana to Neuvitas on the island of Cuba in 1839. Under the leadership of the African, Joseph Cinque, the Negroes murdered the passengers and the crew with the exception of two Spaniards spared to steer the vessel toward freedom. After roaming on the high seas a few days, the vessel came ashore for water and provisions at Culloden Point on the east end of Long Island, and was espied and taken possession of a short while thereafter by Captain Gedney of the United



JOSEPH CINQUE

States Navy. Joseph Cinque, the leader, undertook to escape, but finally yielded. The captives were then brought before the United States Circuit Court in Connecticut, presided over by Andrew T. Judson. As the proceedings lasted for some months, Cinque and his companions were turned over to certain abolition teachers, who so thoroughly grounded him in the fundamentals of education that he

developed into a man of considerable intelligence, showing natural ability as an orator. The outcome of the case was that although Van Buren was ready to remand them, the Supreme Court on appeal decided that the Negroes being free when they left Havana were violating no law in killing those trying to enslave them. They were therefore set free.

The mutiny of the slaves on the *Creole*, en route from Richmond to New Orleans, in 1841, gave rise to another Congressional inquiry in which the right of the United States to exercise authority over slaves on the high seas was questioned. Under the leadership of Madison Washington, who had made his

The Creole Case. escape from slavery in Virginia to Can-

ada, but on returning to rescue his wife had been captured and sent South for sale, one hundred and thirty-four slaves overpowered the officers of the vessel, killed one, and directed the ship to the British port Nassau, where they were held to await instruc-

tions from the British government. When proslavery men in Congress sought to have these Negroes returned to their masters on the ground that they were legally held at the time of their departure, Charles Sumner¹ insisted that the slaves became free when taken, by the voluntary action of their owners, beyond the jurisdiction of the slave States. On the other hand, Daniel Webster, then Secretary of State, contended that inasmuch as slaves were recognized as property by the Constitution of the United States, where slavery



CHARLES SUMNER, a fearless advocate of democracy

¹ See Appendix for Sumner's ideas.

existed, their presence on the high seas did not effect a change in their status. The matter between Great Britain was drawn out into ten years of negotiations and was finally settled in 1853 by arbitration with the provision that the British Government should pay an indemnity of \$110,000 for having permitted these Negroes to go free.

To combat this view Joshua R. Giddings, an antislavery member of Congress, offered in connection with this case in 1842 resolutions to the effect that "slavery, being an abridgment of the natural rights of man, can exist only by force or positive municipal law."² Botts of Virginia thereupon secured the adoption of a resolution to the effect that "this House hold the conduct of said member altogether unwarranted and unwarrantable, and deserving the severe condemnation of the people of this country and of this body in particular." Giddings was,

Giddings'
Resolution.

² Giddings' resolutions were:

1. *Resolved*, That, prior to the adoption of our Federal Constitution each of the several States composing this Union exercised full and exclusive jurisdiction over the subject of slavery within its own territory, and possessed full power to continue or abolish it at pleasure.

2. *Resolved*, That, by adopting the Constitution, no part of the aforesaid powers were delegated to the Federal Government, but were reserved by and still pertain to each of the several States.

3. *Resolved*, That, by the 8th section of the 1st article of the Constitution, each of the several States surrendered to the Federal Government all jurisdiction over the subjects of commerce and navigation upon the high seas.

4. *Resolved*, That Slavery, being an abridgement of the natural right of man, can exist only by force of positive *municipal law*, and is necessarily confined to the territorial jurisdiction of the power creating it.

5. *Resolved*, That when a ship belonging to the citizens of any State enters upon the high seas, the persons on board cease to be subject to the slave laws of such State, and therefore, are governed in their relations to each other by, and are amenable to, the laws of the United States.

6. *Resolved*, That when the brig *Creole*, on her late passage for New Orleans, left the territorial jurisdiction of Virginia, the slave laws of that State ceased to have jurisdiction over the persons on

therefore, twice censured by the proslavery Congress. To show the attachment of his district to free institutions, however, he resigned and appealed to his constituents in the Western Reserve, who immediately returned him that he might introduce these resolutions again.

The interpretation of the constitution was again appealed to when, in the development of the proslavery policy which dominated this country up to the Civil War, the South **The Wilmot Proviso.** actually forced the country into a struggle with Mexico to acquire territory for the extension of slavery. A rather serious question arose when an act appropriating money for the purchase of territory from Mexico was blocked by David Wilmot's amendment providing that in the territory to be thus acquired slavery should be forever prohibited. This amendment caused much trouble years thereafter; for, introduced from session to

board said brig, and such persons became amenable only to the laws of the United States.

7. *Resolved*, That the persons on board the said ship, in resuming their natural rights of personal liberty, violated no law of the United States, and are incompatible with our national honor.

8. *Resolved*, That all attempts to regain possession of or to re-enslave said persons are unauthorized by the Constitution or laws of the United States, and are incompatible with our national honor.

9. *Resolved*, That, all attempts to exert our national influence in favor of the coastwise slave trade, or to place this nation in the attitude of maintaining a "commerce in human beings," are subversive of the rights and injurious to the feelings of the free States, are unauthorized by the Constitution, and prejudicial to our national character.

See *Text* of the resolutions in *House Journal*, 27th Con., 2d Sess.; for the resolution of censure, *ib.*, p. 580. For the discussions see the *Cong. Globe*, or *Benton's Abridgment*, XIV. The diplomatic correspondence regarding the *Creole* is in the *House Exec. Doc. 2*, 27th Cong., 3d Sess., pp. 114-123, and *Senate Doc. 1*, pp. 116-125. See also von Holst's *United States*, II, 479-486; J. Q. Adams's *Memoirs*, XI, 113-115; Wilson's *Rise and Fall of the Slave Power*, I, Chap. 31; Benton's *Thirty Years' View*, II, Chap. 98.

The work of this statesman is treated in Byron R. Long's *Joshua R. Giddings, A Champion of Political Freedom* and in George W. Julians' *Life of Joshua R. Giddings*. See also J. B. Moore's *International Arbitrations*, I, 417.

session, it became the nemesis of the proslavery party in quest of new territory. The proviso evoked from the proslavery advocates the claim that Congress had no right to legislate on this question and that the question of slavery should be decided by those persons who would settle in the said territory.

About the year 1850, when the antislavery agitation was at its height and the various laws of interest to the many contending elements emerged in the form of the Omnibus Bill, several constitutional questions of importance were raised. There came up the question of the admission of California, the paying of certain Texas claims, the organization of territory acquired from Mexico, the abolition of the slave trade in the District of Columbia, and the provision for a more effective fugitive slave law. The friends of slavery objected to having the State of California admitted without passing through the territorial probation period, and did not agree with Henry Clay, who contended that slavery in that State illegally existed. They believed that slavery existed everywhere unless it had been positively prohibited by law. Many northerners objected to paying claims incurred by the acquisition of slave territory and were not disposed to hurry up with the organization of slave States to be formed therefrom.³ As to the prohibition of slavery in the District of Columbia, the southerners were still of the opinion that the Constitution had not given Congress any power to legislate regarding slavery. On the other hand, the friends of freedom were of the opinion that the proposed fugitive slave law intended to impress into the service of slave-catching men who had no inclination to perform such a task, that it interfered with a man's rights as a citizen, and that it was unconstitutional because it did not guarantee the suspects any right of trial by jury and did not permit a fugitive to

The crisis
of 1850.

³ This is well expressed by Giddings's speech in the Appendix.

testify in his own behalf. In the midst of so many conflicting efforts to bring about a compromise between two militant sections, far-sighted men like William H. Seward ⁴ and Henry Ward Beecher saw no hope for peace in the Omnibus Bill.

A more interesting constitutional question arose some years later when out of the territory in the West it was proposed to organize Kansas and Nebraska without regard to slavery. Stephen A. Douglas, the champion of this movement, seemed to stultify him-

**The Kansas-
Nebraska
Question.**

self in trying to harmonize his theory of squatter sovereignty with that of the freedom of the people in determining for themselves how the new commonwealth should come into the Union. How Douglas could make it possible for a man to take his slaves wherever he would



HENRY WARD BEECHER, a champion of freedom

and still hold them as goods and chattels, while at the same time the law would guarantee to the people in a new commonwealth when framing the Constitution the right to decide for themselves whether or not the State should be free, was never satisfactorily explained to the increasing number of antislavery men.

The most formidable of all of these protagonists, however, was not among the first to appear. He was a back-

⁴ See Appendix for Seward's *Higher Law*.

woodsman born in Kentucky and developed to manhood in Indiana and Illinois. As a rail-splitter he could understand the hardships entailed upon those compelled to engage in drudgery. When a young man he went on a flat boat on a trading trip to New Orleans. On the market square he saw human beings auctioned off like cattle, and being deeply impressed with the evil thereof he said to himself that if he ever had a chance to strike slavery he would strike it and would strike it hard. Some years later, when Elijah Lovejoy was killed at Alton, Illinois, by the proslavery leaders because of his diatribes hurled at the bold defenders of that institution, the legislature of the State passed a resolution which seemingly condoned that murder. Thereupon this representative joined with Daniel Stone in a protest to the effect that "they believed that the institution of slavery is founded on both injustice and bad policy." This man was Abraham Lincoln.⁵

Against all temporizing and compromising efforts to placate the mad proslavery advocates, Lincoln persistently warned his fellow-countrymen. He early saw that the country had by its continuation of the policies of the proslavery party decided upon a fatal course of winking at a terrible evil. "Under the operation of that policy," said he, "that agitation has not only not ceased, but has constantly augmented. In my opinion, it will not cease until a crisis shall have been reached and passed. 'A house divided against itself cannot stand.' I believe this government cannot endure permanently half slave and half free. I do not expect the Union to be dissolved—I do not expect the house to fall—but I do expect it will cease to be divided. It will become all one thing, or all the other. Either the opponents of slavery will arrest the further spread of it, and place it where the public mind shall rest in the belief that it is in the course of ultimate extinction; or its advo-

⁵ See Lincoln's speech in the Appendix.

cates will push it forward till it shall become alike lawful in all the States, old as well as new, North as well as South.”⁶

The culmination of the proslavery discussion was the Dred Scott decision. This was the case of a Negro who had been taken from the slave States into free territory a second **The Dred Scott Decision.** time, when he instituted proceedings to obtain his freedom. The case passed through the local and higher courts and finally came before the Supreme Court of the United States, which decided that at that time, when the Constitution of the United States was adopted, Negroes were not regarded as citizens of this country and they could not, therefore, sue as such in the United States courts. That tribunal then had no jurisdiction in such a case and it was dismissed. This was to say that the Negro, so far as the United States Government was concerned, had no rights that the white man should respect, and that although certain sections of the country by regulations were generally free, any part of the country might become slave, should persons owning Negroes choose to settle therein. Slavery was therefore national, while freedom was sectional.

Against this interpretation of the Constitution to justify such encroachment upon the rights of the individual, the friends of freedom persistently protested. Wendell Phillips, the staunch advocate of liberty, equality, **Increasing opposition.** and fraternity, saw in the constitution thus interpreted such an inhuman law that he refused to seek election to Congress because he could not conscientiously take the oath to support it. William Henry Seward, then coming forward as the spokesman of those who dared to engage in the battle for the rights of citizens under the constitution, accepted the challenge in his *Impending*

⁶ Abraham Lincoln, *Speeches and Debates* (New York, 1907), p. 36.

*Crisis and Irrepressible Conflict.*⁷ Salmon P. Chase and Charles Sumner, though not at first militant abolitionists, had reached the conclusion that slavery would have to yield ground to free soil, free speech and free men.

The slavery debate then ceased to be a constitutional question and became largely political. The organization of the Republican Party in 1854, and its all but successful campaign in 1856 with John C. Fremont on the **Slavery in** platform of prohibiting the extension of slav- **politics.** **ery,** made this question the dominant thought of most forward-looking men. Here we see the agitation for the rights of man connecting opportunely with modern economic movements to reduce slave labor to the point of a death struggle with free labor. Although aware of the fact that the civilized world had proscribed slavery, the South was willing to remain in a primitive state to retain it. The North was determined not to yield any more ground to an institution in which it had no interest and against which it had many reasons to be opposed. Then followed the popularization of *Uncle Tom's Cabin*, the famous debates of Lincoln and Douglas, the division of the truncated Democratic Party, the accession of northern liberals to the ranks of the Republicans, and the triumph of the Republican Party in 1860.

The southern States, believing that their last chance to maintain slavery in the Union had passed, thereupon seceded to establish a confederate government in keeping with their institutions. South Carolina took such action December 20, 1860, and before Lincoln had been inaugurated the following **The Last stand of the South.** March all of the cotton States had followed her example. Was secession constitutional? James Buchanan, the weak executive then finishing his term as President, said that

⁷ See Appendix for Seward's thought on the crisis.

these commonwealths had no right to leave the Union, but he did not believe that he had any constitutional power to interfere with their going. This was the most critical period through which the Union had passed, and persons who had for some years observed the development of disintegrating forces doubted that it would weather the storm.

When the Federal Constitution was framed and adopted

1860

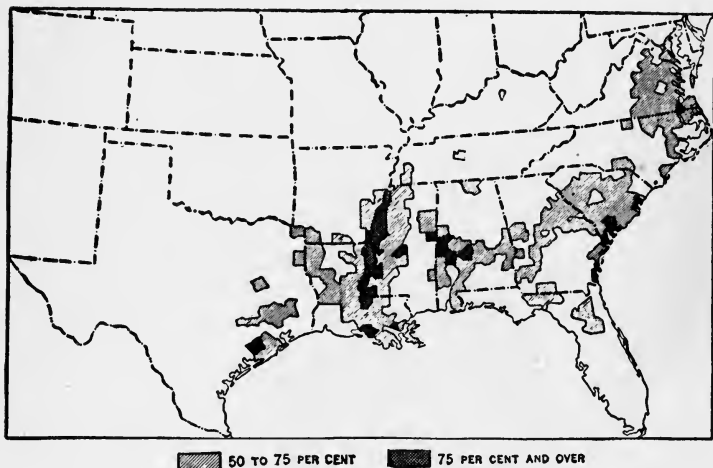

THE DISTRIBUTION OF THE NEGRO POPULATION IN 1860

By permission of the United States Bureau of the Census

few persons were conscious of the fact that the foundation for a durable union of the States had been laid. The very **The nature of the Union.** language of the Constitution itself indicates that a consolidation of the States ratifying that agreement was not clear in the minds of the framers. In the course of time, however, the country developed into a Union, the majority of the States taking the position that it could not be broken. Some States were in doubt as to whether a State could secede at the time of the agitation

of the Alien and Sedition Laws which culminated in the high ground taken by Virginia and Kentucky in their threatening resolutions. More strength for the Union was evidenced when New England, because of its dissatisfaction with the conduct of the War of 1812, felt disposed to make an effort at secession. The Union sentiment was much more pronounced at the time of the nullification of the efforts of South Carolina in 1833, indicating, as Benjamin F. Wade

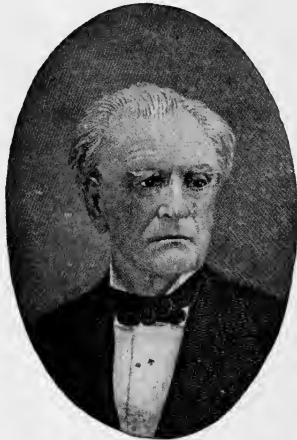

BENJAMIN F. WADE, the
defier of the Seces-
sionists

of Ohio boldly asserted, that there was little chance for a State to leave the Union of its own accord.⁸

In spite of this nationalistic attitude, however, the South had become so much attached to slavery and the North so far removed from it that this institution tended so to **Threats of secession.** widen the breach

that to carry its point the South for three decades threatened the country with secession. Before the two participants in this contest lay the promising West. Each was making an effort to in-

vade that domain to establish there States which would support their respective claims. As a free society expands much more rapidly than a slave community, the North easily outstripped the South and in seeking an advantage by preventing the expansion of slavery in the interest of free labor, it forced the South to the radical position of undertaking secession. These threats were very much pronounced during the ardent slavery debates of 1849 and 1850,

⁸ See Appendix for Wade's speech.

leaving certain sores which the all-comprehending compromise of 1850 failed to heal. And when the agitation had seemingly been all but settled by these arrangements, the matter broke out anew in the effort to provide a govern-

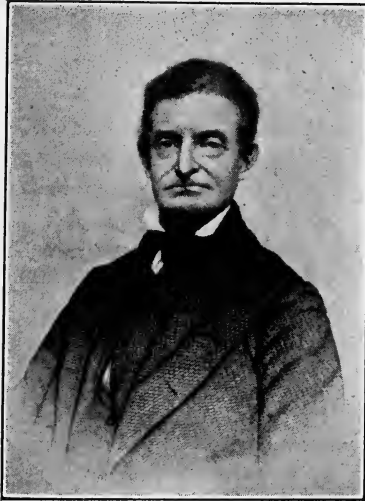

JOHN BROWN

ment for Kansas and Nebraska and in the struggle there between the representatives of the North and South. The bloodshed in Kansas was the beginning of the Civil War, and the raid of John Brown at Harpers Ferry in 1859 was but another event of the same struggle.⁹ Although he overestimated the effect of his exploits he did drive home, however, the fact that a number of people in the North had thought so seriously about slavery as to endanger their lives in try-

ing to exterminate the institution. It made the country realize that something would have to be done to bring the matter to a conclusion, and the Civil War was the crowning event of this long-drawn-out movement.

⁹ See the last words of John Brown in the Appendix.

CHAPTER XV

THE NEGRO IN THE CIVIL WAR

WHEN the war broke out, the President of the United States openly declared that it was not his purpose to interfere with the institutions of the South, meaning of course, that he had no desire to attack slavery in those commonwealths in which it existed. The South, on the other hand, anxious to win favor abroad and knowing how it would harm its cause in foreign countries to have it said that it had undertaken a war to promote slavery, declared its position one of self-defense to maintain its right to govern itself and to preserve its own peculiar institutions. Negroes, therefore, were not to be freed and of course were not to take a part in the war, as it was considered a struggle between white men. This does not mean, however, that Abraham Lincoln had lost sight of the fact that he had been elected by a party opposed to the extension of slavery, nor that he ceased to put forth efforts, whenever possible, to check the institution as he had formerly declared. After the war had been well begun and it was evident that such efforts as the peace convention could not succeed, Lincoln took up with the border States the question of setting the example of freeing the Negroes by a process of gradual emancipation.¹

¹ J. K. Hosmer, *The Appeal to Arms and his Outcome of the Civil War*; J. W. Burgess, *Civil War and the Constitution*; James Ford Rhodes, *History of the United States*, Vol. III; J. B. McMaster, *History of the United States*, Vol. VIII, p. 473; James Schouler, *History of the United States*, VI, 1861-1865, *passim*; William Wells Brown, *The Rising Son*, 341-381; George W. Williams, *History of*

The Negro In Our History

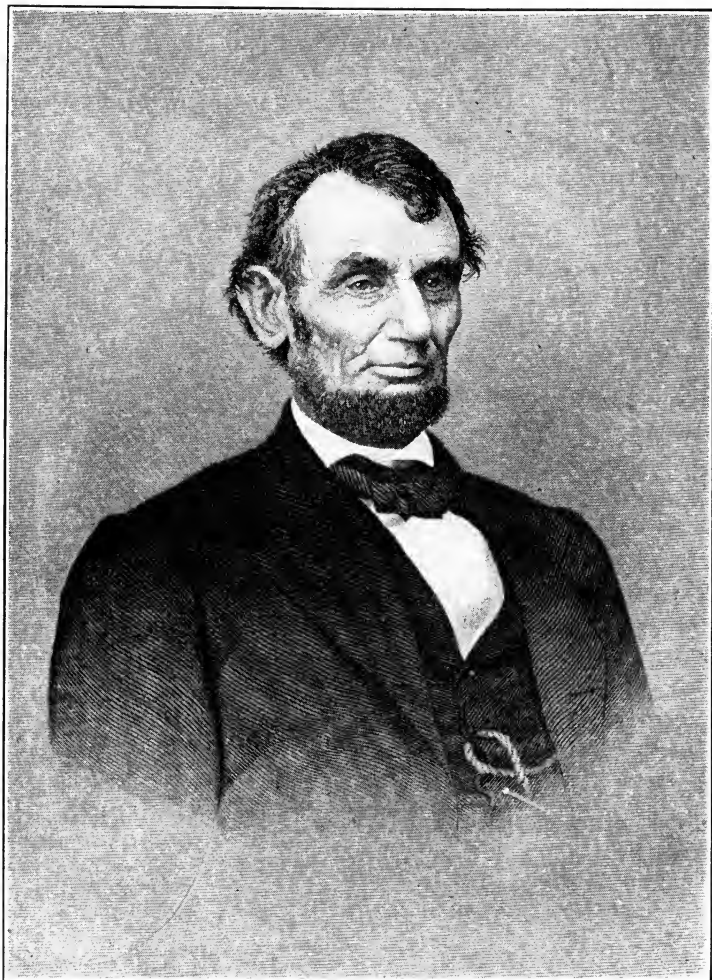

ABRAHAM LINCOLN

Before the war had proceeded very far, however, the Negroes came up for serious consideration because of the many problems which developed out of the peculiar situation in which they were. In the first place, **The Negro** there were in the North free Negroes who **involved**, were anxious to do their share in defeating the purposes of the Confederate States, knowing that the success of their cause meant the perpetuation of slavery. There were in the North, moreover, white men who were of the opinion that free Negroes should share a part of the burden entailed by waging the Civil War. Furthermore, as soon as the invading Union armies crossed the Mason and Dixon line into the South, disturbing the plantation system and driving the masters away from their homes, the Negroes were left behind to constitute a problem for the army. There arose the question as to what was the status of such Negroes. Nominally they were slaves, actually they were free, but there was no law to settle the question. A few slaves who had been taken over by the Union armies from persons in rebellion against the United States, were confiscated by virtue of the legislation providing for this disposition of such property of the Confederates. Yet there were Negroes who did not wait for the invading armies but, when their masters had gone to the front to defend the South, left their homes and made way to the Union camps.²

The first effort to deal with such slaves was made by General Butler at Fortress Monroe in 1861. **Butler's** Such slaves as escaped into his camp in flight **contrabands**, from their masters, he accepted as contrabands of war on the grounds that they had been employed in assisting the

Negro Troops in the War of the Rebellion, passim; William MacDon-ald, *Select Statutes of United States History*, 34-39; and A. B. Hart, *American History Told by Contemporaries*, IV, 181-458.

²The best authority on the Civil War is James Ford Rhodes. See his *History of the United States from the Compromise of 1850 to the Final Restoration of Home Rule in the South*; Volumes I-IV.

Confederate armies and could be confiscated in the same sense that one would take over other supplies of the Confederates. Much discussion was aroused by the action of General Butler, and there was doubt as to whether or not it would be supported by the President. This plan, however, was followed by General Wood, Butler's successor, and by General Banks when he was operating in New Orleans. General Halleck, while operating in the West, at first

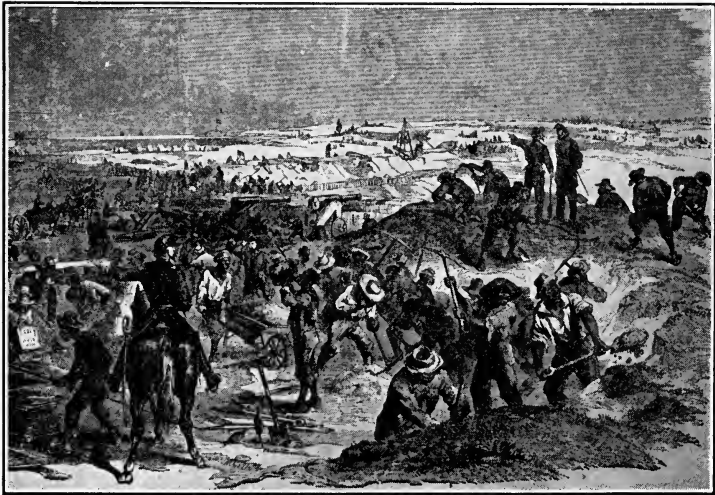

NEGROES IN THE SERVICE OF THE CONFEDERATES

excluded slaves from the camps, as did also General Dix in Virginia. Some generals, like General McCook and General Johnson, permitted slave hunters to come into their lines and reclaim their fugitive slaves. Later, however, General Halleck seems to have receded from his early position. General Grant refused to give permits to those seeking to recapture the Negroes who had escaped from their former masters, and used the blacks at such labor as the building of roads and fortifications, very much as they were first

used by General Butler. This anticipated a policy which was later followed by the United States Army.³

In the course of time, however, the national government saw the necessity of treating the Negro question more seriously. It was evident that if the South continued to use the Negro slaves in building fortifications and roads and bridges and, in fact, to do practically all of the labor required in the army, it was incumbent upon the Union armies operating in the South to do likewise. Lincoln, therefore, soon accepted the policy of using the slaves in this capacity, receding from his former position of thinking that should the slaves be given any encouragement to leave their homes they might start a servile insurrection, and in promoting such he would weaken himself in his hold on the North.

At first these Negroes did not find their life a pleasant one. They were suddenly thrown among strange men from the North, who had never had much dealing with the Negroes and whose first impression of them was not favorable. Arriving among these soldiers, naked, hungry, and often diseased—moreover, lacking the initiative to provide

**The Negro
question
serious.**

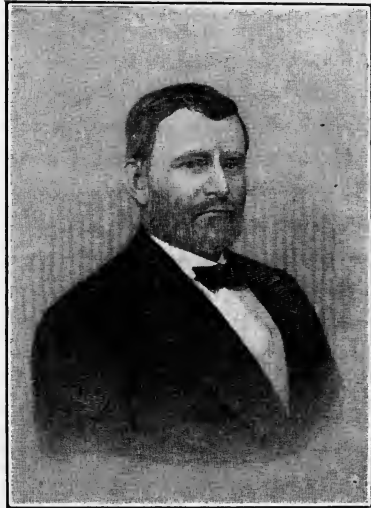

U. S. GRANT

**The Negro in
the camps.**

³ G. W. Williams, *History of the Negro Troops in the War of the Rebellion, passim*; William Wells Brown, *The Rising Son*; and John Eaton, *Grant, Lincoln, and the Freedmen*.

for themselves what the average freeman was expected to do, they presented a piteous spectacle which baffled the skill of the army. The refugees were finally organized under directions sent out from headquarters of the army, and placed in charge of a superintendent having under him sufficient assistants to relieve most of the cases of distress and to make some use of the able-bodied Negroes.

Most of these refugees were sent to Washington, Alexandria, Fortress Monroe, Hampton, Craney Island, Yorktown, Suffolk, Portsmouth, Port Royal, South Carolina, and certain camps of the West near Memphis. At one time, in the camp at Arlington, just across from Washington, there were as many as 30,000 Negroes. This number increased to almost 100,000 in the various camps near Washington, in the proportion that the war advanced and the territory of the Confederates became overrun by the invading Union armies.⁴ It was easy to find employment for those in camps near cities. Some of them were put to work on deserted plantations. Others were incorporated into the army as teamsters, mechanics, and common laborers. Sojourner Truth, who served the Union army as a messenger and a spy, rendered valuable service in these camps by teaching the refugees cleanliness and habits of industry.

It was arranged also to send a number of these Negroes from the congested districts in the loyal States as fast as opportunities for their employment presented themselves. Those found near cities and manufacturing points, where **Fugitives sent North.** there was a demand for labor, were in some cases employed to do work in which white men sent to the war had been engaged. A good many passed

⁴ For more extensive treatment, see John Eaton, *Grant, Lincoln and the Freedmen*; E. L. Pierce's *The Freedmen of Port Royal, South Carolina*; G. W. Williams's *The History of Negro Troops*, 90-98; E. H. Botume's *First Days Amongst the Contrabands*, and *The Atlantic Monthly*, XII, 308.

through Cairo, Illinois, into the West, and some others were sent through York, Columbia, Harrisburg, and Philadelphia to points in the North. This, however, did not continue to a very great extent, for the reason that there was some apprehension that the North might be overcrowded by such freedmen. Several schemes were set forth to transport this population, and when this number was still further increased by the thousands of Negroes emancipated in the District of Columbia in 1862, Abraham Lincoln himself thought to get rid of these freedmen by promoting a scheme to colonize them in foreign parts.

To carry out this plan as he desired, he sent a special message to Congress expressing the necessity for Congressional action in the way of an appropriation to finance such an enterprise. The Secretary of State, there-
**Lincoln's
colonization
plan.**

Negroes, thinking that they could be induced to accept Negro emigrants from this country. He conducted correspondence then with Great Britain, Denmark, France, Sweden and all of the South American countries. In the beginning it became evident that only two countries, Liberia and Haiti, each of which were settled by Negroes, were willing to admit these refugees. But the Negroes themselves, because of their prejudice against Liberia and the unsuccessful effort at colonization in Haiti, did not care to emigrate to those countries. Favorable replies, however, finally came from the Island of A'Vache. The government immediately planned to send a colony to that settlement by virtue of an appropriation made by Congress. Bernard Koch approached the government and induced the authorities to make with him a contract for the transportation of Negroes to this island.

At the same time Koch connected himself with certain

business men in New York, who, in return for commercial advantages to be gained there, agreed also to finance the enterprise. When this double dealing was discovered the United States Government severed connection with Koch. The capitalists, however, still determined to conduct this enterprise, engaged the services of Koch as governor. Accordingly a number of Negroes were sent to this island in the year 1862, but owing to the unfavorable conditions and their lack of initiative, unusual suffering ensued. It was necessary for the Government, because of the many complaints received therefrom, to send a special investigator to report on the situation, and finally, on account of his unfavorable report, to dispatch a transport to bring the emigrants back to the United States.

Lincoln, however, remained fundamentally an antislavery man in spite of this untoward enterprise, but he religiously adhered to his gradual emancipation schemes. He would not permit the antislavery sentiment of the country to force upon him the policy of instant emancipation. As there were in the field generals availing themselves of every opportunity to weaken the slave power, much vigilance had to be exercised to avoid extreme measures which might embarrass the Federal Government. Taking the advanced position that the slaves should be free, Fremont issued a decree abolishing slavery in Missouri. It was necessary for Lincoln to say to him on September 2, 1861: "I think there is great danger that the closing paragraph, in relation to the confiscation of property and the liberating slaves of traitorous owners, will alarm our southern Union friends and turn them against us; perhaps ruin our rather fair prospect for Kentucky. Allow me, therefore, to ask that you will, as of your own motion, modify that paragraph so as to conform to the first and fourth sections of the act of Congress, entitled *An Act to*

Confiscate Property used for Insurrectionary Purposes.”

The following May, Lincoln had to deal similarly with Major-General Hunter, then stationed at Port Royal, South Carolina. This commander had issued a declaration to the effect that the commonwealths within his jurisdiction having deliberately declared themselves no longer under the protection of the United States of America and having taken up arms against the United States, it became a military necessity to declare martial law, and as slavery and martial law were incompatible in a free country, the persons of these States held to service were declared free. Lincoln then issued a proclamation declaring that neither General Hunter nor any other commander or person had been authorized by the government of the United States to take such action and that the supposed proclamation in question, whether genuine or false, was altogether void so far as respects such a declaration. He considered it sufficient at that time to rely upon his proposed plan for the gradual abolition of slavery on the compensation basis recently accepted by Congress.

Writing Hunter again on the eleventh of the same month, Lincoln said: “The particular clause, however, in relation to the confiscation of property and the liberation of slaves appeared to me to be objectionable in its nonconformity to the act of Congress passed the 6th of last August upon the same subjects; and hence I wrote you, expressing my wish that that clause should be modified accordingly. Your answer, just received, expresses the preference on your part that I should make an open order for the modification, which I very cheerfully do. It is, therefore, ordered that the said clause of said proclamation be so modified, held, and construed as to conform to, and not to transcend, the provisions on the same subject contained in the act of Congress, entitled *An Act to Confiscate Property used for Insurrectionary Purposes.*”

It was growing more and more apparent, however, that the Negro would have to be treated as a citizen of the United States. In the army he had demonstrated his capacity as a man. He had shown that he could become industrious, that he was thrifty, and that he would serve unselfishly. Where he had an opportunity to toil upward he succeeded. It was therefore recommended by a number of men, and among them General Grant himself, that certain Negroes be so equipped and trained that they might be employed not only as teamsters and mechanics and the like, but as soldiers. This change of policy was necessary not merely for sentimental reasons but because the North, in its effort to subjugate the cavalier South, had found those warriors too well trained and too spirited to be easily conquered. In most of the important engagements the South had won. Farragut had captured New Orleans, Thomas and Grant had won a few victories in the West, and the *Monitor* had held its own with the *Merrimac* in defending the nation's cause, but the Union army had been twice ingloriously defeated at Manassas, and McClellan had lost in his Peninsular campaign and had thrown away his advantages gained at Antietam. As the army was unsuccessful under Burnside at Fredericksburg, and under Hooker at Chancellorsville, the North, growing tired of the war, was becoming fertile ground for seeds of a second secession sown by copperheads who were planning to establish another republic in the Northwest. It was deemed advisable, therefore, to bring the Negro into the army that he might help to save the Union. By this time, too, the Federal Government had reached the position that slavery, the root of most of the evils of the country and the actual cause of the war, would have to be exterminated. Congress passed sweeping confiscation acts by virtue of which the armies could take over slaves, and, in 1862, Lincoln came forward

**The
Emancipation
Proclamation.**

with the Emancipation Proclamation, declaring that after the first of January in 1863 all slaves in those parts of the country where the people might remain in rebellion against the United States, should be declared free.

*That on the first day of January in the year of our Lord, one thousand eight hundred and sixty-three, all persons held as slaves, within any state, or designated part of a state, the people whereof shall then be in rebellion against the United States, shall be then, thenceforward, and forever free. and the executive govern-
 including the military and naval authority, thereof
 ment of the United States, will, during the war,
~~discontinue~~ ~~office of the present~~ ~~maintain~~, re-
 and maintain the freedom of
 cognize, such persons, ~~as being free~~, and will
 do no act or acts to repress such persons, or any
 of them, in any efforts they may make for their
 actual freedom.*

FACSIMILE OF THE ORIGINAL DRAFT OF THE EMANCIPATION
 PROCLAMATION

Northern men like General DePeyster, General Thomas W. Sherman, General Hunter, Governor Yates of Illinois, Henry Wilson, and Charles Sumner, had been emphatic in urging the United States Government to arm the Negroes to weaken the South. And well might the United States

Army take this action, for the seceders had not only made use of the Negroes as laborers, but in Tennessee and Louisiana had actually organized free Negroes for military service in the Confederate Army. Yet, although the confiscation acts and other legislation justified the employment of Negroes, Lincoln hesitated to carry out these provisions. In 1862, however, General David Hunter, commanding in South Carolina, issued an order for recruiting a Negro regiment, which in a few months was in the field. This caused much dissatisfaction among the Unionists, who did not feel that Negroes should be called on to fight the battles of a free republic. An effort was made to embarrass General Hunter, but he emerged from the investigation without being reversed, although he did not have the support of Lincoln. General J. W. Phelps, under General B. F. Butler in Louisiana, undertook to carry out Hunter's policy, but his superior was then willing to use the Negroes as laborers only.

Certain leaders in the North, however, were becoming a little more aggressive in their demand for the employment of Negroes as soldiers. On August 4, 1862, Governor Sprague of Rhode Island urged Negro citizens to enlist, and that same month Butler himself appealed to the free people of color of Louisiana to come to the defense of the Union. The next month a regiment of Negroes marched forth to war as the "First Regiment of Louisiana Native Guards," soon changed to the "First Regiment Infantry Corps d'Afrique." There was later organized the "First Regiment Louisiana Heavy Artillery." Other Negro regiments soon followed, and before the end of 1862 four Negro regiments had been brought into the military service of the United States. Then came the "Kansas Colored Volunteers" early in 1863, and when the Emancipation Proclamation had been signed Lincoln officially authorized the raising of Negro troops. Then followed the famous Fifty-

fourth Massachusetts and so many other troops that there was established in Washington a special bureau for handling affairs respecting these units, aggregating before the end of the war 178,975.

In keeping with the custom which was all but followed during the World War, the Negro troops were commanded almost altogether by white officers. There was some doubt



ROBERT GOULD SHAW LEADING THE FIFTY-FOURTH MASSACHUSETTS REGIMENT

that the Negro would make a good soldier and, of course, the Negro officer was then almost impossible. **The use of** Massachusetts, however, commissioned ten **Negro troops.** Negro officers, Kansas three, and the military authorities a considerable number in Louisiana. Negroes held altogether about seventy-five commissions in the army during the Civil War. Among these officers were Lieutenant Colonel

William N. Reed of the First North Carolina, a man well educated in Germany. He made a gallant charge with his regiment at the battle of Olustee, Florida, where he was mortally wounded. In the Kansas corps there were Captain H. Ford Douglass, First Lieutenant W. D. Matthews and Second Lieutenant Patrick A. Minor. In the U. S. C. T. One Hundred and Fourth Regiment there were Major Martin R. Delaney and Captain O. S. B. Wall of Company K. Dr. Alexander T. Augusta, who was surgeon of the U. S. C. T. Seventh Regiment, was finally breveted with Lieutenant-Colonel. Dr. John V. DeGrasse was assistant surgeon of the U. S. C. T. Thirty-fifth Regiment. Charles B. Purvis, Alpheus Tucker, John Rapier, William Ellis, Anderson R. Abbott and William Powell were hospital surgeons at Washington, D. C.

One might inquire, too, as to exactly what was the status of the Negro troops. In the first place, they were not treated as the equals of white men. There was objection to giving them the same compensation offered the whites.

The status of the Negro soldiers. / In the matter of bounties there was a discrimination against Negro soldiers who were slaves on April 19, 1861. This caused dissatisfaction among the Negro troops, whose families thereby seriously suffered. Sergeant William Walker was shot by order of court martial because he had his company stack arms before the captain's tent for the reason that the Government had failed to comply with its contract. The Fifty-fourth of Massachusetts nobly refused to receive its pay until it had been made equal to that of the whites. Negro troops, moreover, were often used by white troops for fatigue duty. Because of this notorious discrimination many of these soldiers became restive, sullen and even insubordinate.

Yet these Negroes distinguished themselves as soldiers.

Men under whom these troops fought in battle were loud in praise of their gallantry and martyrdom. Negroes served in almost all parts of the South. They engaged in the perilous South Edisto Expedition to burn a bridge above Walton Bluff to aid General Sherman, and participated in the action at Honey Hill. Speaking of their behavior in the expedition to Dobey River in Georgia, General Rufus Saxton said that they fought with most determined bravery. Surgeon Seth Rogers, operating in South Carolina, said that braver men never lived. Colonel T. W. Higginson himself believed that "it would have been madness to attempt with the bravest white troops what he successfully accomplished with the black." Even in the failure to carry Fort Wag-

ner, a point necessary to the capture of Charleston, the Negro troops bore the severest tests of valor, following their gallant leader, Colonel Robert Gould Shaw, who in this charge fell mortally wounded.

In the Mississippi Valley they fought still more bravely. Negro troops made six such desperate charges on a fort at Port Hudson that a reporter said that the deeds of heroism performed by these black men were such as the proudest white men might emulate. General Banks said in referring to their behavior: "It gives me great pleasure to report that they answered every expectation. Their conduct was heroic; no troops could be more determined or more daring." Other troops from



COL. THOMAS W. HIGGINSON, a commander of Negro troops

Valuable
service.

Bravery in
the West.

Louisiana showed themselves equally brave at Milliken's Bend. Reporting this battle, Captain Matthew M. Miller said: "So they fought and died, defending the cause that we revere. They met death coolly, bravely; nor rashly did they expose themselves, but all were steady and obedient to orders." And so went others to death in the massacre at Fort Pillow in Tennessee, where the Confederates, in keeping with their bold declaration not to give quarter to the slaves striking for their own freedom, slaughtered them as men kill beasts.

In the Department of the Potomac the Negro maintained there his reputation as a soldier. Under General Wild, at Fort Powhatan in 1864, the Negro soldiers bravely held their ground against the heavy onslaught of Fitzhugh Lee's brilliant soldiers, who were badly worsted in the conflict. When General Grant was endeavoring to reduce Petersburg, a brigade of Hinck's Negro division brilliantly dashed forward and cleared a line of rifle-pits and carried a redoubt ahead. They did valiant work of the same order at South Mountain and died bravely in carrying the fortified positions of the Confederates at New Market Heights and nearer to Petersburg. In the dash along the James and in the pursuit of Lee's weakened forces, the Negroes under arms maintained their bearing as brave men and came out of the Civil War as heroes.

In carrying on the Civil War many constitutional questions arose. Chief among these was the suspension of the writ of habeas corpus in the cases of certain copperheads or "pacifists" in the North, who arrayed themselves against the United States Government and at one time even threatened the country with an additional secession. The Constitution provided for the suspension of the writ in times of great danger, but it is not clear whether the framers of the Constitution contemplated that this power should be exercised by the President of the

**Bravery
along the
Potomac.**

**Constitutional
questions.**

United States. Furthermore, those who asserted that the writ could be suspended under certain conditions did not concede the right to the President to suspend it in sections where the courts were open and where the armies were not in operation. The most important case of this kind was that of Milligan, when by operation of the courts the plaintiff undertook to secure his liberty through a writ of habeas corpus and the President of the United States interfered.

There arose also a question as to taxing the people unduly to support a government waging war to coerce certain States, interfering with the freedom of the press by the censorship established during the war, enforcing conscription acts compelling men to fight against their will, and finally, by action of Congress, providing for gradual emancipation in certain border States and the abolition of slavery in the District of Columbia. Whether Congress could constitutionally legislate respecting slavery was still a question, but the Civil War gradually brought the country to a realization that Congress, representing the people of the United States, had adequate power in the premises. Because of vesting the President with dictatorial power to wage the war effectively, however, there came from certain sources a bitter antagonism which led to the organization of a party of opposition advocating the Union as it was and the Constitution as it is.

The most important constitutional matter coming up during the Civil War was that of the Emancipation Proclamation itself. Lincoln had for some time wondered whether or not he had such authority, and long hesitated to issue this mandate declaring free all the Negroes in the districts then in rebellion against the United States. Fremont, Hunter and Butler, in charge of Union armies, had undertaken to do this, but had to be restrained. One of the members of Lincoln's cabinet

Taxation.

**The
emancipation
problem.**

was of the opinion that he had no such power and that such a step would doubtless do more harm than good. In the end, however, just after a number of encouraging Union victories, the Emancipation Proclamation was issued and had its desired effect, but to become legal it had to be fortified by the Thirteenth Amendment. Few persons have since questioned the Thirteenth Amendment, but the Fourteenth and Fifteenth which followed thereupon have since given rise to all sorts of constitutional questions involving the rights of the Negroes.

CHAPTER XVI

THE RECONSTRUCTION

As soon as the Union armies began to occupy a considerable portion of the territory of the so-called seceded States, there was some thought about the rehabilitation of these commonwealths.¹ As to the exact position of these commonwealths which had undertaken to withdraw from the Union, there

Lincoln's
reconstruction.

was a wide difference of opinion. Lincoln himself was of the impression that a State could not get out of the Union. "Once in the Union, forever in the Union," was his theory. Lincoln therefore issued, on December 8, 1863, a proclamation setting forth a plan for the reconstruction of these commonwealths. Making exception of those who had served in the civil or diplomatic service of the Confederate Government or in judicial stations, of those who had served in the army or navy with rank above colonel, or who had abandoned Congress to aid the rebellion, resigned commissions in the army, or cruelly treated Negroes or white persons in charge of them, Lincoln pro-

¹ There are no scientific studies of the nation-wide reconstruction in which the Negroes took a part. W. L. Fleming, James F. Rhodes, W. A. Dunning and J. W. Burgess have written works in this field, but they are biased and inadequate. Almost a score of other so-called scientific studies of Reconstruction in the various States have been made, but these merely try to make a case for the white man's side of the question as to whether the reduction of the Negro to serfdom was just. John R. Lynch in his *Facts of Reconstruction*, and W. E. B. DuBois in his *Reconstruction, and Its Benefits* (in the *American Historical Review*, XV, No. 4) have undertaken to point out these defects.

claimed full pardon to the people in the Confederate States with the restoration of all rights of property except as to slaves if they should take and subscribe to an oath of allegiance to the United States Government and thenceforward keep and maintain this oath inviolate.

Lincoln further proclaimed that whenever in any of these States there should be loyal persons to the number of not less than one-tenth of the votes cast in such States at the presidential election of the year 1860, each having taken **The ten per cent basis.** this oath and not having violated it and being a qualified voter by the election law of the State existing prior to the secession, the commonwealth should establish a State government. This government should be democratic, should be recognized as the true government of the State, and should receive the benefits of the constitutional provision which declares that the United States shall guarantee to every State in this Union a republican form of government.

Lincoln also proclaimed that any provision which these commonwealths thus restored might adopt in relation to the freed people within their limits, which should recognize **Interest in the freedmen.** and declare their permanent freedom, and provide for their education, which might then be consistent as a temporary arrangement with their condition as a laboring, landless and homeless class, would not be objected to by the President. The President was of the opinion that the name of the State, the boundary, subdivisions, constitution, and the former code of laws should be maintained, subject only to the modification made necessary by the conditions elsewhere stated in the proclamation, and such others, if any, not contravening the conditions of the proclamation and which might be deemed expedient by those framing the new State government.

Upon this basis Lincoln undertook the reconstruction of

the States of Louisiana, Arkansas, and Tennessee prior to the close of the Civil War as soon as loyal men to the number of one-tenth of the voters exercising suffrage in the presidential election of 1860 were found in those commonwealths. When the cessation of arms finally came, several other rebellious commonwealths, thinking that the States as such could never be destroyed, proceeded to organize similar governments,

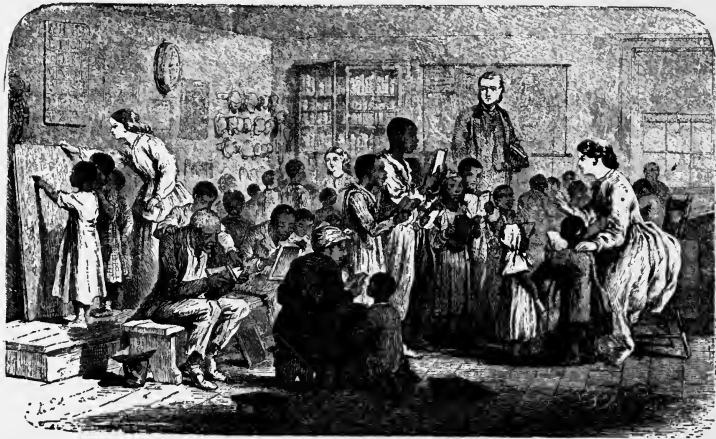

TEACHING THE FREEDMEN

complying with the conditions of repudiating the Confederate debts, declaring allegiance to the Union, and ratifying the Thirteenth Amendment. They, therefore, feeling that they would be immediately admitted to the Union with the rights and privileges formerly enjoyed by the Southern States, elected representatives and senators to sit in Congress. Believing that Lincoln's position in this case was sound, Andrew Johnson, his successor, undertook to carry out this policy. This, however, was not acceptable to the statesmen then in control of affairs, and the right of such

persons to serve as representatives of these commonwealths was questioned.

They found in Congress men led by Thaddeus Stevens, who was of the opinion that inasmuch as the Southern States had rebelled and had failed to maintain their cause, **Various theories.** they were then subject to the same treatment as any other people in a conquered territory. This, to be sure, conflicted with certain other views, as it admitted that secession had been temporarily successful, and conflicted with the administrative plans of Lincoln and Johnson to the effect that secession was merely an unsuccessful effort and that the States were still in the Union. Shellabarger contended that secession was a nullity, which although it could not assume control of the territory in which it existed, nevertheless worked a loss in the status of a member of the Union, and the citizens remaining therein were, therefore, exclusively subjected to the jurisdiction of the United States Government. This was endorsed by Sumner, Fessenden and Wilson, and became, in fact, the theory of the Republican Party in Congress, which grew antagonistic to the administration and led to the long differences of opinion between that body and Johnson, finally culminating in the impeachment of the President.

There came also to the national capital various reports which further convinced the gentlemen in charge of affairs in Congress that the South was unwilling to grant the Negro **The unwilling South.** the right to enjoy the fruits of the victory of the Civil War, for the freedmen were being oppressed almost to the extent of being enslaved. The first reports were brought in by General Grant and Carl Schurz, the former contending that the southerners were in the main willing to accept the changes effected by the Civil War, and the latter being of the opinion that the rebellious commonwealths were not loyal and intended to reënslave the Negroes. Some of these States were enacting black

The Reconstruction

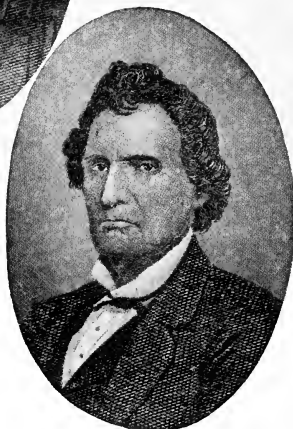
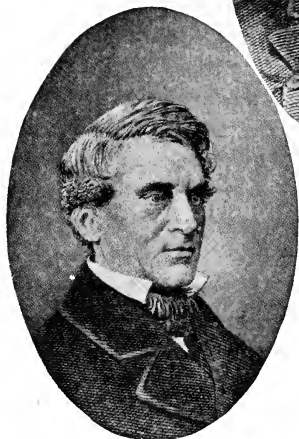
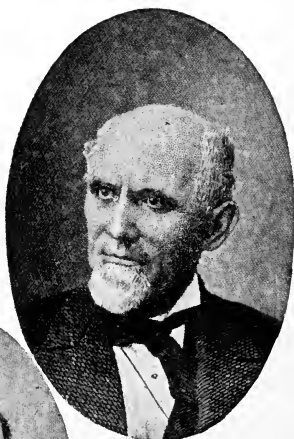

SOME FACTORS IN THE RECONSTRUCTION

WILLIAM P. FESSENDEN

SAMUEL SHELLABARGER

CARL SCHURZ

FREDERICK T. FRELINGHUYSEN

THADDEUS STEVENS

codes providing for apprenticeship, penalizing the vagrancy of Negroes, and interfering with the civil rights of the freedmen. Many of the blacks, having wandered about or flocked to the towns where they too often were reduced to poverty and subject to temptations and vicious influences, tended to retrograde rather than advance. The vagrancy laws, therefore, generally provided for fines, corporal punishment, indenturing for a certain period of service, and in a few cases required that every Negro should be attached to some employer. Furthermore, there had set in a general intimidation of Negroes, and in some parts, as in Louisiana, large numbers of the race were massacred by antagonistic whites, with no excuse but that of trying to regain the lost cause. Assured that the situation was deplorable, Congress proceeded to draft the Fourteenth Amendment as a condition of readmission of a seceded State to the Union, endeavoring to prevent any State from making or enforcing a law which would encroach upon the privileges or immunities of citizens of the United States, deprive them of life, liberty or property without due process of law, or withhold from any one within its jurisdiction the equal protection of the law. In this way the South, by taking a radical position in its unwise application of its power to deal with persons over whom it would have been given more control, brought upon itself a military rule from which it would not have suffered if it had been disposed to treat the freedmen humanely.

These reports led also to the organization of what is known as the Freedmen's Bureau,² the commission established for the protection and the assistance of the freedmen. Some such idea had for some years been expressed from

² On the twenty-fifth of May the committee reported the House bill with a substitute amendment, and the bill thus amended passed the Senate on the twenty-ninth of June by a vote of 21 to 9. The select committee of the House recommended that the amendments of the Senate be disagreed to and further action was postponed until Decem-

time to time in Congress. A bill "to establish a bureau of emancipation" was reported in the House, December 22, 1863, by Eliot, of Massachusetts, from the **The Freed-**
Select Committee on Emancipation, and men's Bureau. then recommitted. The bill was reported with amendments on the thirteenth of January, 1864, and on the first of March passed the House by a vote of 69 to 67. In the Senate the bill was referred to the Select Committee on Slavery and Freedmen, of which Charles Sumner was chairman. A bill to establish a bureau of freedmen was reported from the committee on the twelfth of April. On the third of March the report of a second conference committee was agreed to by both houses. The measure to establish the department was vetoed by President Johnson who, in giving his reasons, so antagonized the leaders in Congress as to widen the irreparable breach between the executive and legislative departments. This bill, with certain objectionable features removed, was later passed over the President's veto, but had to be amended thereafter.

The act provided for the appointment of a commissioner with a number of assistants under the administration of the President to care for the freedmen in the districts in rebellion or controlled by the Union army. Primarily the Freedmen's Bureau was intended to aid refugees and freedmen by supplying them with provisions and in taking up abandoned lands in the South, which were to be distributed in parcels of not more than forty acres each. On account of misrepresentations many Negroes expected from this quarter forty acres of land and a mule for each of the landless freedmen, and this prospective charity tended to produce vagrancy and shiftlessness among people indulged

ber. On the twentieth of December a conference committee was appointed. The report of the committee was accepted by the House on the ninth of February, 1865, by a vote of 64 to 62, 56 not voting; but it was rejected by the Senate on the twenty-second by a vote of 14 to 24. See also the Freedmen's Bureau Act in the Appendix.

as dependent children. The Freedmen's Bureau was vested with the power to build school houses and asylums for the Negroes, and it was proposed to give it unusual power in its jurisdiction over all civil and criminal cases where



GEN. O. O. HOWARD, head of the Freedmen's Bureau and founder of Howard University

equality in civil rights and in the application of justice was denied on account of race, color, or previous condition of servitude. With this unusual power vested in machinery coming from without the State and intended to benefit persons recently enslaved, the Freedmen's Bureau became a source of much irritation to the whites of the South. Grant thought that the officers of the Freedmen's Bureau were a useless set of men and recommended that the work be placed in charge

of army officers. It was for a number of years directed by General O. O. Howard, the founder of Howard University.

When Congress finally decided to ignore Johnson's reconstruction schemes, a committee was appointed to work out a more acceptable plan. After some deliberation these gentlemen returned with a majority and a minority report.

Congressional recon-struction. The majority report, representing the views of the Unionists, was to the effect that the attempted secession of eleven States had resulted in the loss of their stateship and in their becoming disorganized communities, but that although the State governments in the same had been destroyed, the common-

wealths had not escaped the obligations of the Constitution and the authority of the United States Government. The minority report, representing the secessionist theory, was that a State could never be anything less than a State, regardless of what its deeds may be, and each was, therefore, entitled to the same powers, rights and privileges under the Constitution as those given any other State. It is needless to say that under these circumstances the minority report had little weight.

Congress thereupon proceeded in accordance with the views of the majority to work out a plan for the control

of the disorganized States. In spite of the President's opposition and his vetoes, it was decided to divide the seceded States into five military districts, to each of which the President would assign an army of-

**Military
districts.**

an officer of not lower rank than a brigadier general, with a sufficient force to enable him to carry out the laws of the Union. The commanders were to govern these districts by martial law as far as



JOHN M. LANGSTON

in their judgments the reign of order and the preservation of public peace might demand. No sentence of death, however, could be carried out without the approval of the President. To escape from this military government, a rebellious State had to accept universal manhood suffrage of all male citizens of twenty-one years of age without regard to color, race or previous condition of servitude. This election would provide for the framing of a State constitution through delegates to be chosen, excepting persons who were disqualified by participation in the rebellion. There would have to be a ratification of this

constitution by a majority of the voters as designated by the same law of suffrage for the delegates of the convention. These States, moreover, would have to ratify the Fourteenth Amendment, which protected the Negroes from the oppression of the whites in that it guaranteed to them the enjoyment of the privileges and immunities of citizens without regard to race, color or previous condition of servitude. The South had refused to ratify this amendment.

Some of the States immediately availed themselves of this opportunity to be relieved of the military régime, for there was among them a natural antago-

Different nism to martial law.
courses Other States, Vir-
followed. ginia, Georgia and
Texas, however, refused to take advantage of this concession, hoping to find a better solution of the problem by adopting the policy of watchful waiting. The



JOHN R. LYNCH, a member of Congress

citizens of these States found out that the military government was more acceptable than the governments so quickly organized in some of the other Southern States, and decided then for the time being to obey the dictum of the army. In the course of time there was an enlargement of the white majority by the extension of the terms of granting pardon to those who had participated in the rebellion, and as there was already a larger percentage of white persons than Negroes in these three States when the time did come for them to organize State governments, there soon developed a majority opposed to radical reconstruction. The other States in the South, from 1868 to about 1872, became

subjected to what is commonly known as Negro carpet-bag rule.

To call this Negro rule, however, is very much of a mistake when, as a matter of fact, most of the local offices in these commonwealths were held by the white men, and those Negroes who did attain some of the higher offices were

usually about as competent as the average whites thereto elected. Only twenty Negroes served in Congress from 1868 to 1895. The Negroes had political equality in the Southern States only a few years, and with some exceptions their tenure in Congress was very short.

Hiram R. Revels **Not a Negro** of Mississippi com- régime.

pleted an unexpired term in the Senate and B. K. Bruce served there six years. John M. Langston, the Negro member from Virginia, served in the House one term. From North Caro-

lina there were sent to the House of Representatives, John A. Hyman for one term and James E. O'Hara, H. P. Cheatham and George H. White for two terms each. Jefferson F. Long represented a district of Georgia a part of a term. Josiah T. Walls of Florida served in the House two terms. Alabama elected to Congress Jere Haralson, Benjamin S. Turner and James T. Rapier, who served one term each. Louisiana sent Charles E. Nash for one term, and Mississippi John R. Lynch for two. South Carolina had the largest number of Negro representatives in the House. Joseph H. Rainey of that Commonwealth sat in Congress five terms; Richard H. Cain, two; Robert C.

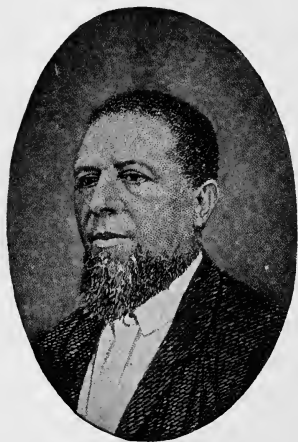

H. R. REVELS, U. S. Senator
from Mississippi

The Negro In Our History

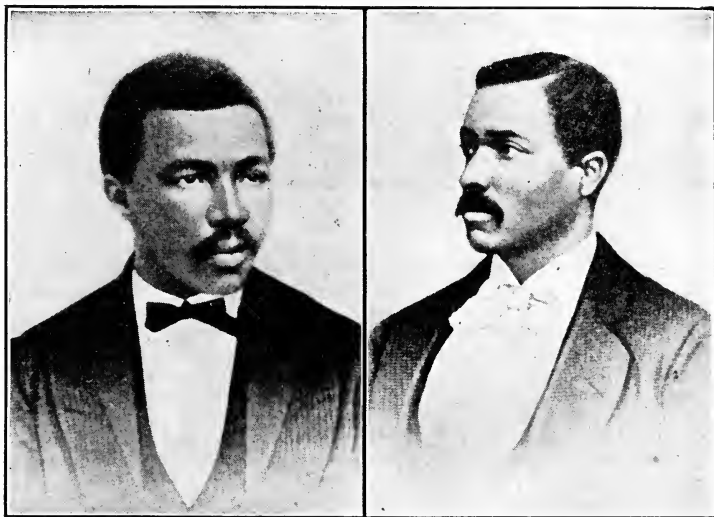

SOME NEGRO CONGRESSMEN

ROBERT B. ELLIOTT
ROBERT C. DELARGE

JOSIAH T. WALLS
RICHARD H. CAIN

DeLarge, one; Alonzo J. Ransier, one; Robert B. Elliott, two; Robert Smalls, five; Thomas E. Miller, one; and George W. Murray, two.

The charge that all Negro officers were illiterates, ignorant of the science of government, cannot be sustained. Some of

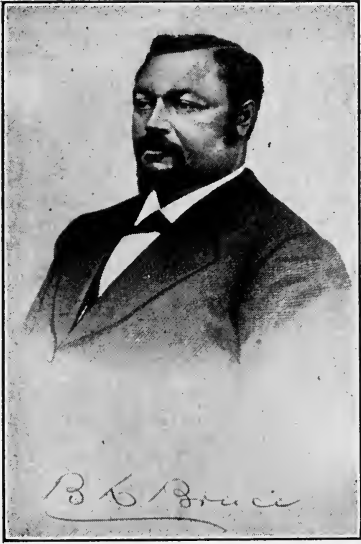

B. K. BRUCE, U. S. Senator from Mississippi

them had undergone considerable training and had experienced sufficient mental development to be able to discharge their duties with honor. Hiram R. Revels spent two years in a Quaker sem-
inary and was later in-

Literacy of voters and officers.

structed at Knox College; B. K. Bruce was educated at Oberlin College. Jere Haralson learned enough to teach. R. H. Cain studied at Wilberforce. James T. Rapier was well educated in a Catholic school in Canada. Benjamin Turner clandestinely received a

fair education in Alabama. James E. O'Hara obtained a secondary education. Robert Brown Elliott, educated at Eton College, England, had, according to Frederick Douglass, no peer in his race except Samuel R. Ward. John M. Langston, after finishing both the college and theological courses at Oberlin, practiced law in Ohio. John R. Lynch, as evidenced by his addresses and writings, was well educated by his dint of energy, although he had only a common school training. Most Negroes who sat in Congress during the eighties and nineties, moreover, had more

formal education than Warren G. Harding, now President of the United States.

Other Negro officeholders, furthermore, were liberally trained. Richard T. Greener, a Reconstruction officeholder in South Carolina, was the first Negro graduate of Harvard College. F. L. Cardozo, another functionary

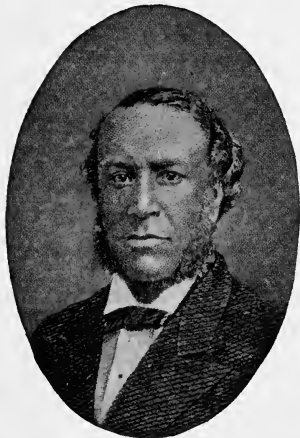

JOSEPH H. RAINEY, a member
of Congress

in the same State, was educated at the University of Glasgow, Scotland. E. D. Bassett, who distinguished himself as an educator and as Minister to Liberia, studied the classics, mathematics and general literature at Yale after being graduated at the Birmingham Academy and the Connecticut State Normal School. P. P. S. Pinchback admirably united common sense with his fundamental education obtained largely at Gilmore's High School in Cincinnati, Ohio, prior to the war.

Were Negroes in general capable? To what extent were they qualified to discharge the duties of citizens? It is true that many of them were not prepared to vote, and decidedly disqualified for the positions which they held. In some of the legislatures, as in Louisiana and South Carolina, more than half of the Negro members could scarcely read or write and had, therefore, to vote according to emotions or the dictates of the demagogues, as, of course, it has been true of legislature composed entirely of whites. In the local and State administrative offices, however, where there were frequent chances for corruption, very few ignorant Negroes ever served. In

fact, most Negroes insisted on finding the best qualified candidates for important positions. That they often failed in obtaining such is not due to the shortcomings of the Negro but to the leadership of the white adventurers and to the refusal of ex-slaveholders to coöperate with the freedmen in establishing the Reconstruction gov-



JAMES T. RAPIER, a member of Congress

ernments on a sounder basis.

Most of the local, State and Federal offices, however, were held not by Negroes but by southern white men, and by others who came from the North and profited by the prostration of the South. They were in many respects self-fish men, but not **White men in control.**

always utterly lacking in principle. The northern whites, of course, had little sympathy for the South and depended for their constituency upon the Negroes, who could not be expected to placate the ex-slaveholders. Being adventurers and interested in their own affairs, the carpet-baggers became unusually corrupt in certain States, administering affairs not for the benefit of the body politic but for their own personal aggrandizement. Yet although Negroes were implicated in these offenses, few of them materially profited by this procedure. Most Negro officers who served in the South came out of office with an honorable record. Such was the case with J. T. White, Commissioner of Public Works and Internal Improvements in Arkansas, M. W. Gibbs, City Judge in Little Rock, J. C. Corbin, State Superintendent of Schools in the same State, F. L. Cardozo, State Treasurer of South Carolina, T. Morris Chester, Brigadier General in charge

of the State Guards of Louisiana, and P. B. S. Pinchback, Lieutenant and Acting Governor of Louisiana. Others who held office elsewhere lived up to the same record. Chief among these may be mentioned Frederick Douglass, who served in the District of Columbia as Marshal and Recorder of Deeds and abroad as Minister to Haiti.

Whether or not the Negro was capable, whether he was honest, however, had little to do with the southern white man's attitude toward the Negro office holders. To produce evidence that the Negroes lacked these essentials, the whites well knew, **Prejudice a factor.** would help them to justify themselves to the world for using such harsh measures to overthrow the new régime. But the Negro was unacceptable merely because he was black, because he had not enjoyed the distinction of wringing his bread from the sweat of another's brow. Government, as the southern man saw it, should be based on an aristocratic exploitation of the man far down. As the slaveholders had for centuries enjoyed this exclusive privilege, they could not but bear it grievously that it had been suddenly taken away.

That the new governments were corrupt was not an exception to the rule of that time. With the reorganization of things throughout the country after the Civil War, and **Corruption explained.** the opening up of new industries and opportunities in the undeveloped parts of this country, there came an era of speculation, dishonest business, and corrupt governments, implicating the highest State and Federal functionaries. There never was a more corrupt



P. B. S. PINCHBACK, acting Governor of Louisiana

government than that conducted by the whites, constituting the Tweed ring in New York. The very persons who complained of the corruption in the Negro carpet-bag governments and who effected the reorganization of the State governments in the South when the Negroes were overthrown, moreover, became just as corrupt as the governing class under the preceding régime. In almost every restored State government in the South, and especially in Mississippi, the white officers in control of the funds defaulted. These persons who had been so long out of office came back so eager to get the most out of them that they filled their own pockets from the coffers of the public.

In contradistinction to this rule of stealing from the public treasury, Debuclet, the Negro who served as Treasurer of the State of Louisiana and who, when the government of that State was taken from the Negroes by the restored aristocrats, had still two years to serve, was investigated with a view to finding out some act of misuse of the public funds that he might be impeached and thrown out of office. The committee, of which E. D. White, late Chief Justice of the United States Supreme Court, was chairman, after much deliberation reported that his funds had been honestly handled and that there were no grounds on which proceedings against him could be instituted.

**Excellent
record of
Debuclet.**

The gravest charge against the Negroes seemed to grow out of the unwritten law that the superior white race should not be ruled by its inferiors. That there should be unusual friction in communities where persons, who a few years prior to their elevation to citizenship had served as goods and chattels, should at that time be passing among the whites as civil and military officers, should excite little surprise. But true students of history know that the Negroes were not especially anxious to put themselves forward. While there were a good many among them seeking to be

Haughtiness.

placed where they could not serve, the majority of the blacks were anxious to secure the coöperation of the best whites. But because of the unusual antagonistic attitude of the former slaveholders, feeling that the Negro should have no part in the government at all, they refused to coöperate, hoping that they could in some way effect the complete elimination of the Negro from politics, as they have done in recent years. The result, therefore, was that the Negroes were in the beginning compelled to support for office white men who had never been tried and who had in some cases given evidence of dishonest purposes.

The argument against this, however, is that the Negroes should not have been enfranchised and that the government should have been organized among the loyal whites. To **Enfranchise-** this it may be replied that there were few loyal **ment question.** whites, and many of those who pretended that they were and undertook to organize governments proved to be just as oppressive as they ever had been, and in fact undertook to reëstablish slavery. Had there been a close coöperation among the best whites in the South and a gradual incorporation of the intelligent freedmen into the electorate, many of the mistakes made would have been obviated; and the recent steps backward towards lynching and peonage would not have been made.

These criticisms of the carpet-bag government had the desired effect among the poor and ignorant whites who, reared under the degrading influences of slavery, could not **Ku Klux Klan.** tolerate the blacks as citizens. The Negroes thereafter were harassed and harried by disturbing elements of anarchy, out of which soon emerged an oath-bound order called the Ku Klux Klan, terrorizing the Negroes with lawlessness and violence. Congress, therefore, deemed it necessary to pass a series of repressive measures, known as "force bills," to protect the Negroes in the enjoyment of the civil and political rights. The President was author-

The Reconstruction



THE NEW FREEDOM, the first mixed jury in the District of Columbia

ized to suppress insurrection in the Southern States where and when local authorities were powerless and might suspend the writ of habeas corpus. The jurisdiction of the Federal courts was so extended as to take cognizance of cases in which Negroes complained of being deprived of their rights. This legislation also contemplated the use of Federal troops to secure fair election in these States. While these measures offered temporary relief they caused such deep resentment in the South, especially among those whites who were endeavoring to suppress mob violence, that the South tended to become a smoldering volcano awaiting an opportunity for eruption.

The dénouement came from President Rutherford B. Hayes in the withdrawal of the troops to the support of whom he probably owed his doubtful election. The occasion

The withdrawal of troops. was the consideration of the question of continuing the use of troops in South Carolina.

Hayes said: "In my opinion, there does not now exist in that State such domestic violence as is contemplated by the Constitution as the ground upon which the military power of the National Government may be invoked for the defense of the State, but these are settled by such orderly and peaceable methods as may be provided by the Constitution and laws of the State. I feel assured that no resort to violence is contemplated in any quarter, but that, on the contrary, the disputes in question are to be settled solely by such peaceful remedies as the Constitution and the laws of the State provide."

The withdrawal of the national troops from the South gave much relief to the whites in that section and pleased a majority of the Northern citizens, who, despite the efforts of the Southerners to break up the Union, could not support the policy of forever afflicting them with martial law. The Negroes and their sympathizers, however, have always considered this the most unstatesman-like act any President

has committed since the war. They contend that it almost immediately restored to power the unreconstructed element which, because of the color of the freedmen, segregated, disfranchised and lynched them to the extent that the United States can now be criticized for not complying with that clause of the Constitution guaranteeing every State a republican form of government. These troops should have undoubtedly been withdrawn by gradual process, in the proportion that the districts thus relieved exhibited evidence of the ability to protect all citizens in the enjoyment of their rights and privileges.

The closing chapter in the reconstruction is its undoing. The whites reclaimed the governments from the Negroes. Not only were they anxious to take over the offices and the public funds, but to prevent the Negroes from participating thereafter in the governments of those States they enacted measures which by peculiar provisions in the laws of suffrage for the qualifications of voters eliminated most Negroes from the electorate on the grounds that they could not read and write, did not own property, or were not descendants of persons who had voted prior to certain dates. In this way they hedged around the Fifteenth Amendment, which provided that the right to vote should not be denied on account of race, color or previous condition of servitude. They, moreover, curtailed the privileges of the Negroes by segregation laws dealing first with places of amusements like theaters and parks, with the schools, and finally with farming and residential districts in most parts of the South.

The undoing
of the re-
construction.

CHAPTER XVII

FINDING A WAY OF ESCAPE

THE abridgment of the Negroes' rights came as such a calamity that for a generation following the restoration of the reactionaries to power, the Negroes were in a state of confusion seeking to extricate themselves from their difficulties.¹ There then ensued a most cruel persecution of the blacks by the degraded and impecunious poor whites. Although assured that the Negroes could not under the circumstances soon regain their political rights, certain criminal communities have found special delight in killing and lynching Negroes on account of offenses for which a white man would hardly be accused, if the complainant happened to be black. The local newspapers, by their art of psychological appeal to the race prejudice of the masses, have succeeded in convincing the public that the general cause of these lynchings was criminal assault, but statistics show that ordinary misdemeanors of Negroes have been the sole excuse for three out of every four of these lynchings.

The extent to which the country has been disgraced by

¹ George W. Williams, *History of the Negro Race*, II, 375-380; C. G. Woodson, *A Century of Negro Migration*, chs. VII and VIII; *The Atlantic Monthly*, XLIV, page 222 *et seq.*; *The Vicksburg Commercial*, May 6, 1919; *The Nation*, XXVIII, 242, 386; *The American Journal of Social Science*, XI, 1-35; *Public Opinion*, XVIII, 370 *et seq.*; *The American Law Review*, XL, 29, 52, 205, 227, 354, 381, 547, 590, 695, 758, 865, 905; *Reports of Committees of the Senate of the United States for the First and Second Sessions of the Forty-sixth Congress*, 1879-1880, pp. iii-xiii.

the institution of lynching may be more easily estimated by a few statistics. According to General Sheridan, 3,500 persons were killed in the South during the first **Lynching.** decade after emancipation; 1,884 were killed and wounded in 1868, and probably 1,200 between 1868 and 1875. Most of these massacres occurred in the disturbed area of Louisiana. Following that period the number of Negroes annually lynched in the whole country aggregated between fifty and a hundred, and the whole number for the reconstruction and readjustment periods not less than 2,500. As the Negroes were no longer valuables attached to owners, as horses or cattle, there was little to restrain the degraded class from murdering them in communities where few white men had any conception of the blacks as persons entitled to life, liberty, and the pursuit of happiness.

The economic situation in the South in the meantime became critical. The poor whites who were unwilling to labor themselves so disturbed the Negroes that their employment was precarious. The ex-slaveholders, more- **The economic** over, imposed upon the Negroes willing to **situation.** work. The Negroes were the only dependable laboring classes in the South, and too many were trying to live on the fruits of the Negroes' labor. Whether aware or not of being duped, the Negroes had to seek employment by the whites, as they had no capital to operate farms and factories independently. Some of those who, during the happiest days of reconstruction, succeeded in acquiring property, saw it thereafter seized on the plea of delinquent taxes and transferred to the master class.

The land in the South, moreover, remained mainly in large tracts held by planters, who, except in the case of poverty, never desired to dispose of it; and even if they had been thus inclined, the Negroes could not un- **Land Tenure.** der the existing régime quickly earn sufficient money to purchase large holdings. There was then no chance for the

Negroes to develop at once into a desirable class of farmers. They then became mainly a wage-earning element dependent on the will of their employers. As few of the Negroes could read and write, they were cheated in signing contracts and had to suffer the consequent privations aggravated by cruelty, if they unduly complained.

The wage system of the South early failed to give satisfaction, except in the sugar district. The planters then made the experiment of working on shares, but had to **Wage system** abandon this because the employer was not **tried.**

always able to advance the Negro tenant supplies pending the growth of the crop, and some insisted that the Negro was too indifferent and lazy to make the partnership desirable. It was then decided to resort to the renting system, which became the accepted tenure in the cotton district. While this system apparently threw the tenant on his own responsibility, it frequently made him the victim **Rent system.** of his own ignorance and the rapacity of his landlord. As the Negroes could do no better they had to pay such high rent that they hardly derived from their labor adequate returns to support their families.

The worst feature of the rent plan was its iniquitous concomitant, the credit system. Having no capital to begin with, a Negro tenant became dependent on his landlord for **The credit** advance of supplies of tools, food and clothing **system.** during the year, secured by a lien on the crop. As these new tenants had had only a few years of freedom to learn business methods, they became a prey to dishonest men who, through their stores and banks, extorted from the Negroes practically all of their earnings before the end of the year. A few honest planters desired to protect the Negroes by supplying them at reasonable prices; but subject to usury themselves, their efforts availed little. It was necessary then for the Negro tenant to begin the year with three mortgages, covering all he owned, his labor

for the coming year, and all he expected to acquire during that twelvemonth. According to an observer of the time, he paid "one-third of his product for the use of the land; he paid an exorbitant fee for recording the contract, by which he paid his pound of flesh; he was charged two or three times as much as he ought to pay for ginning his cotton; and, finally, he turned over his crop to be eaten up in commissions, if any was still left to him."

Various means of escape from these conditions were therefore considered. Some Negroes still looked forward to a change in politics, believing that a reconstructed Republican Party would again interfere in southern affairs to relieve the Negroes. Others had the idea that religion would be the solution of the problem. They insisted that the calamities of the race resulted as an affliction with which they had been visited because of their wandering away from God, who would right their wrongs as soon as they heeded His pleading voice.

**Remedies
proposed.**

The unrest, however, first found a safety valve in the exodus of the Negroes. During the seventies a considerable number of them moved from North Carolina to Indiana, where because of the pivotal political situation in that State their migration gave rise to the accusation that they were being brought thither for the purpose of carrying doubtful States for the Republican Party. A Congressional investigation proved that these charges were absurd. The larger number of the Negroes who, during this period, were induced to move North, went not to Indiana but to Kansas, because of its known attitude towards the black man as evidenced by its willingness to bleed in behalf of freedom.

This movement was an organized one, promoted by two men who were not widely known as race leaders but attained distinction as the organizers of one of the most disturbing migrations ever effected among Negroes. They were Henry Adams of Louisiana

**The exodus
to the West.**

and Benjamin or "Pap" Singleton of Tennessee. Seeing that the Negroes had almost lost the fruits of their emancipation and that there was little hope that their situation would be greatly improved, they had organized a committee which they later increased by the hundreds to circulate



R. T. GREENER

information as to the intolerable oppression of the blacks and the opportunities in the West for relief therefrom. In this way, according to these promoters, they interested 100,000 or 200,000 Negroes, although not more than one-fourth or one-fifth of this number actually went West.

This unusual movement of the Negroes threatened the South with economic ruin. The thinking class saw that the section was

soon to lose the economic foundation of its prosperity, and that if something were not speedily done the land would doubtless become a waste place in the wilderness. Meetings, therefore, were called among the whites and the blacks to induce the latter to remain where they were. The most important meeting of this kind was that held at **Alarm among the planters.** Vicksburg, Mississippi, on May 6, 1879. There were assembled the representatives of the best of both races seeking to reach some conclusion as how to deal with the situation. Frank expressions as to the causes of the grievances were made on both sides, and most persons concerned were willing to make such sacrifices of personal feeling and opinion as to remedy the evils complained of.

Unwilling to rely upon moral suasion, however, the whites resorted to force to stop the exodus by denying the Negroes

transportation and imprisoning them on false charges; but Negroes to the number of many thousands continued their way West despite this opposition—despite even the discouragement of their greatest leader, Frederick Douglass, who advised them to remain in the South where they would have sufficient numbers to wield political power. The promoters of the movement were fortunate in having the support of Richard T. Greener and John M. Langston, who, having sufficient foresight to see that the United States Government would not soon interfere in behalf of the Negroes in the South, advised them to flee from political oppression to a free country, considering it a hopeful sign that the blacks had passed through that stage of development of appealing to philanthropy into that of appealing to themselves.

This rapid migration was soon checked, but the Negroes gradually continued to go West into the industrial centers of the Appalachian mountains and into the Southwest. The masses of the Negroes, however, became settled in the South in a condition not much better than their former state; for the planters forgot their promises of better treatment just as soon as the exodus ceased. The economic adjustment after the Civil War, culminating in the resumption of specie payments in 1879, moreover, brightened somewhat the dark age through which the South was passing. During the eighties and nineties the masses of Negroes could do little more than merely eke out an existence, but following this period some of them prospered sufficiently to appreciate the difference between free and slave labor. The income of the average Negro even then, however, was very small. The most fortunate Negro tenants or farmers did not generally come to the end of the year with more than they needed to keep them while pro-

**The resort
to force.**

**The migration
checked.**

ducing their crop during the next. The rural wage earner did well to receive for his toil, from sunrise to sunset, twenty-five or thirty cents a day, including board restricted to half a gallon of meal and half a pound of fat bacon. Mechanics believed that they were highly favored when they earned from seventy-five cents to a dollar and a half a day.

In the midst of such circumstances, the Negroes could not establish homes and educate their children.

It was of much assistance to the Negroes in the

Education
tried.

South, however, that the

North raised considerable money and sent some of her best citizens to found institutions for the enlightenment of the freedmen. This philanthropic scheme presupposed that education in the classical field was the urgent need of Negroes, in that



J. C. PRICE

it was essential to a proper understanding of the problems of government, and that when this was supplied the masses thus enlightened would have an advantage by which they could triumph over all opposition. Heeding this call to avail themselves of such opportunities, Negroes not only crowded these institutions, like Howard, Fisk, Lincoln, Morehouse, and Atlanta, but began to establish higher institutions of their own. Out of these schools came not many scholars, but enthusiastic teachers devoted to the enlightenment of their people, a large number of race-leading preachers proclaiming religion as the solution of the problem, many well informed orators,

like J. C. Price and William Pickens, and educating controversialists, like Kelly Miller and W. E. B. DuBois. Under different conditions these men, no doubt, would have been historians, scientists, or mathematicians, but their race was passing through the ordeal of kith and kin democracy, and their talent had to be impressed into the service of

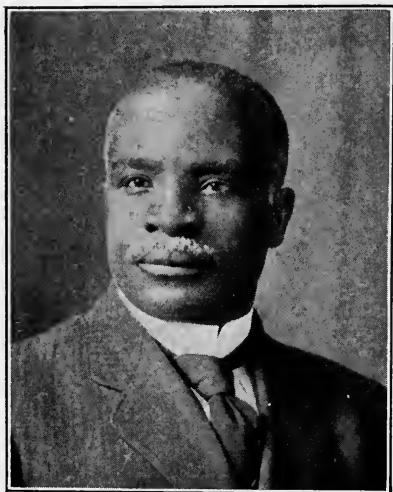

KELLY MILLER

exposing the folly of the reactionaries promoting the return to medieval civilization in proscribing the citizenship of the Negroes.

The majority of the Negroes in the South finally be- **Resignation**
c a m e set- to fate.

tled to conditions as they were, endeavoring to make the most of an undesirable situation; but Negroes who, having experienced mental development, had had their hearts fired

with the desire to enjoy the rights so eloquently set forth by their uncompromising leaders, endeavored to escape from their political and civic humiliation. To these Negroes of talent it seemed that the South would never be a decent place to live in, especially when the North turned a deaf ear to the pleadings of their spokesmen sent thither to portray to the children of the Negroes' former friends exactly how the fruits of their victory for human rights had been permitted seemingly to perish from the earth. After the reconstruction period, the North was too busy in developing its industries and had es-

established too close relations with the South to think of severing these ties. The prevailing opinion was that the South should be permitted to deal with the Negroes as it felt disposed.

As the South, in this position of renewed supremacy, became increasingly intolerant of the talented freedmen, many of them left. To this the whites offered no objection whatever. The exodus of the intelligent Negroes was much desired by the southerners, for every one migrating diminished the chances of the Negro for mental development, a thing which most southerners believed spoils the Negro. It has been the policy of most Anglo-Saxon nations to keep in ignorance the exploited races, that in their ignorant state the one group may be arrayed against the other to prevent them from reaching the point of self-assertion. In keeping with that same policy southerners would not only not encourage but would have little dealing with the talented Negroes, and in making desire father to the thought, insisted that there were no intelligent Negroes. Well might some sections reasonably reach this conclusion as to the mental development of the Negroes, if it is to be judged by the amount of money spent for their education. In its backward state the South could not afford large appropriations for education, but in most of the districts the Negro public schools were almost a mockery, and with the exception of the State industrial schools almost no provision at all was made for the higher education of the Negro after the undoing of reconstruction.

In the effort to get away from the South there was a renewal of the colonization scheme under the leadership of **Colonization** Bishop H. M. Turner. With the encourage-
again. ment of Senator Morgan of Alabama, who, after the reactionaries had well completed the task of depriving the Negroes of their rights, felt that they should

then go to a foreign land to develop independently a nation of their own, it seemed that the plan might prove feasible. Some thought again of Africa as the place of refuge, but the memory of the antebellum struggle of the free Negroes to defeat that enterprise made that continent too frightening to attract many. In the early nineties, a few Negroes emigrated to Mapimi, Mexico, from which, after some hardships, they returned to their homes in Georgia and Alabama. Resorting to Africa then, 197 Negroes sailed from Savannah, Georgia, for Liberia in 1895. The expedition to Liberia was not as unsuccessful as that to Mexico, but the deportationists soon discovered in carrying out their plan that it is impossible to expatriate a whole race.



BISHOP H. M. TURNER, a fearless spokesman for his people

Many of the talented Negroes who had been conspicuous in politics, thereafter decided to yield to the white man's control, and devoted themselves to the accumulation of wealth. But, as hell is never full and the eyes of man are never satisfied, the mere domination did not meet all of the requirements of the degraded class of whites. Slavery had made them brutal. They had been accustomed to drive, to mutilate, to kill Negroes, and such traits could not be easily removed. The reign of terror, ostensibly initiated to overthrow the carpet-bag governments by means of the Ku Klux Klan, continued, and it became a special delight for the poor whites to humiliate and persecute the

Negroes who had acquired education and accumulated some wealth. The effort was to make the Negro realize that he lives in a white man's country in which law for the Negro is the will of the white man with whom he meets. The Negroes had to undergo punishment for presuming to assume the reins of government during the reconstruction. They had to be convinced that this country will never permit another such revolution. Further legislation to restrict suffrage inalterably to the whites as a majority, to deprive Negroes of the right to serve in the State Militia, to segregate them in public conveyances, and exclude them from places of entertainment, soon followed as a necessity for maintaining white supremacy, so precarious has its tenure at times seemed.

At the same time the laboring Negroes not only saw themselves overwhelmed by a rent and credit system which would not pass away, but lost further ground in the new form of slavery called peonage, which once had legal sanction in Alabama, Florida, Georgia, Mississippi, North Carolina, **Peonage.** and South Carolina. This was a sort of involuntary servitude by which the laborer is considered bound to serve his master until a debt he has contracted is paid. The origin of this was in a custom in Mexico, and the opportunity lay in the poverty of the Negroes who had to borrow from the whites. In working to pay these debts they must still borrow to live. As the white man was the bookkeeper and his statement of account was law in the courts, it was the former master's prerogative to say how much the peon owed, to determine exactly when he should leave his service, or whether he should ever leave.

Peons during these years were recruited from another source. In collusion with courts arranging with the police **Peonage and the courts.** to arrest a required number of Negroes to secure the desired amount in fees and fines, innocent Negroes were commonly arrested, and when fined in

court had to agree to enter the service of some white man, who would pay their fines for the opportunity to reduce them to involuntary servitude. A brief account from one of these peonage districts is sufficient to illustrate this point. Passing along the street where a Negro was employed by a white man, a sympathetic observer noticed that his employer frequently kicked and cuffed the Negro when he was not working satisfactorily. "Why do you stand this? Why do you not have this man arrested for assault?" inquired the observer. "That is just the trouble now," responded the Negro. "I complained to the court when another white man beat me, and the judge imposed upon me a fine which I could not pay, so I have to work it out in the service of this man who paid it to have the opportunity to force me to work for him." The Supreme Court of the United States undertook to put an end to such legislation in 1911 by declaring the Alabama peonage law unconstitutional, but in the many districts where there is no healthy public opinion to the contrary or where the employer is a law unto himself, peonage has continued in spite of the feeble effort of the Federal Government to eradicate the evil.

These increasing encroachments convinced many thinking Negroes that they should no longer endure such humiliation. They could not adequately educate their children at public expense, although taxed to support the public schools; they enjoyed little security in the possession of property, and dared not defend their families from insult. Their first thought, then, was to go North. For more than a century the North, despite its lack of hospitality for the Negroes, had remained in their minds as a place of refuge. From time immemorial Negroes had gone to that section, and sometimes in considerable numbers. During the nineties and the first decade of the present century these numbers decidedly

Negroes going North.

increased and brought nearer home to the North the so-called race problem.

There went first the dethroned politicians who, when failing to secure employment in Washington, endeavored to solve the problem by migration. A few Negroes well established in business, moreover, closed up their affairs and moved out. The educated Negroes—especially the Negro college graduates who were imbued with the principles of justice set forth by Pickens, Trotter and DuBois—had too much appreciation for freedom to remain longer where they were politically and socially proscribed. A few professional men, who under the undesirable conditions were reduced to want, also made their escape. Intelligent laborers who knew that they were not receiving the proper returns from their labor tired also of the ordeal and went in due time to try life in other parts. In fact, this slow but steady migration was a gradual drawing off from the South of the most advanced classes, those best qualified to lead the race more rapidly toward achievement. In its backward state, however, the South could not appreciate this loss, so willing has it been to pay the high cost of race prejudice.

The undesirable feature of this migration was that it was mainly to the cities. The hostility of the trades unions to the Negroes was already a handicap rendering their presence in large northern cities a problem, and the increase of numbers resulting from this influx aggravated the situation. It was further aggravated in the course of time when, because of the increasing popularity of the North, many Negroes “just happened” to go. Some went on excursions to Columbus, Indianapolis, Chicago, Cleveland, and the like, and never returned South. In the North, moreover, educated Negroes had to follow drudgery rather than to practice professions or work at

Politicians leaving the South.

The rush to cities.

skilled labor as they could in the South. They were willing, however, to pay this price for social and political rights, hoping that at some time the fates would bring it to pass that they would secure an economic foundation in the North. The attainment of this end, notwithstanding some encouraging events, however, has been a battle against well-established precedents in the effort to maintain the economic supremacy of the laboring whites, who feel that they should not be compelled to compete with Negroes. In labor, as in other things, they contend, the sphere of great remuneration must be restricted to the white man, and drudgery to the Negro.

Some systematic efforts were made to break down the barriers of these trades unions. White men, like Eugene V. Debs, high in the councils of these bodies, attacked this medieval attitude of the white laborers, but to no avail. As Negroes in the North and West, therefore, **Trades unions.** were pitted against the trades unions, they embittered much the feeling between the races by allying themselves with the capitalists to serve as strike breakers. In this case, however, the trades unions themselves were to be blamed. The only time the Negroes could work under such circumstances was when the whites were striking, and it is not surprising that some of them easily yielded then to the temptation. In those unions in which the Negroes were recognized they stood with their white coworkers in every instance of making a reasonable demand of their employers. Some of these unions, however, accepted Negroes merely as a subterfuge to prevent them from engaging in strike-breaking. When the Negroes appealed for work, identifying themselves as members of the union in control, they were turned away with the explanation that no vacancies existed, while white men were gladly received.

As a rule, therefore, the Negroes migrating to the North

had to do menial service. It was pathetic for the traveler to see Negroes, once well established in a business in the

In menial service.

South, reduced to service as porters to earn a living in the North. The Negroes were so scattered in the North that they did not supply the opportunity for mutual help, and since the whites were not willing to concede economic opportunity the northern Negroes were, so to speak, isolated in the midst of a medieval civilization founded on the caste of color. While the migrating Negroes of intelligence hid their lights under a bushel in the North, the illiterate Negroes in the South, in need of their assistance in education and enterprise, too often fell into the hands of the harpies and sharks, many of whom had the assistance of unscrupulous Negroes in plundering these unfortunates.

Results in the South.

There came forward then a Negro with a new idea. He said to his race: "Cast down your buckets where you are." In other words, the Negroes must work out their salvation in the South. He was a native of Virginia. He had

Booker T. Washington's idea.

been trained at Hampton and under adverse circumstances had founded a school in Alabama, affording him the opportunity to study the Negroes in all their aspects. Seeing that the need of the Negro was a foundation in things economic, he came forward with the bold advocacy of industrial education of the Negroes "in those arts and crafts in which they are now employed and in which they must exhibit greater efficiency if they are to compete with the white men." The world had heard this before, but never had an educator so expounded this doctrine as to move the millions. This man was Booker T. Washington.

The celebrated pronunciamento of Washington was set forth in his address at the Atlanta Exposition in 1895, and his educational theory and practice have not since ceased to be a universal topic. He insisted that since the Negroes

had to toil they should be taught to toil skillfully. He did not openly attack higher education for Negroes, but insisted that in getting an education they should be sure to get some of that which they can use.

**The Atlanta
Address.**

In other words, the only education worth while is that which reacts on one's life in his peculiar situation. A youth, then, should not be educated away from his environment, but trained to lay a foundation for the future in his present situation, out of which he may emerge into something above and beyond his beginnings.

Washington's plan was received by the white people in the South as a safe means by which they could promote Negro education along lines different from those followed in the education of the white man, so as to make education



BOOKER T. WASHINGTON

mean one thing for the whites and another for the Negroes. The North was at first divided on the question. The sympathetic class felt that such a policy would reduce the Negroes as a whole to a class of laborers and thus bar them from the higher walks of life through which the race must come to recognition and prominence. The wealthy class of whites in the North took the position that there was much wisdom in Washington's plan accepted. The industrial program, with the millions with which they

have endowed Tuskegee and Hampton, and the support given the many other schools established on that basis, they, in less than a generation, have brought most northern people around to their way of thinking.

The Negroes, however, with exception of a small minority, regarded this policy as a surrender to the oppressors who desired to reduce the whole race to menial service, and they proceeded militantly to attack Washington, branding him with **Opposition to Washington.** the opprobrium of a traitor to his people. In the course of time, however, when the South, following the advice and example of Washington, reconstructed its educational system for Negroes and began to supply these schools with faculties recommended by men interested in industrial education and too



W. E. B. DuBois

often by Washington himself, there were gradually elevated to leadership many Negroes who, in standing for industrial education, largely increased the support of Washington among his people. When, moreover, his influence as an educator extended into all ramifications of life, even into politics, to the extent that he dictated the rise and fall of all Negroes occupying positions subject to the will of the whites, that constituency was so generally increased that before he died there were few Negroes who dared criticize

him in public or let it be known that they were not in sympathy with his work.

Against this policy, however, there always stood forth some Negroes who would not yield ground. The most outspoken among these were W. M. Trotter and W. E. B. DuBois. These men have had the idea that the first efforts to secure recognition for the

**Trotter and
DuBois.**

Negro must come through agitation for higher education and political equality.

What they demand for the Negro is the same opportunity, the same treatment, generally given the white man. To accept anything less means treachery. Feeling that Washington's position was a compromise on these things, they persistently denounced him from the rostrum and through the press in spite of the great personal sacrifices which they thereby suffered. DuBois lost the

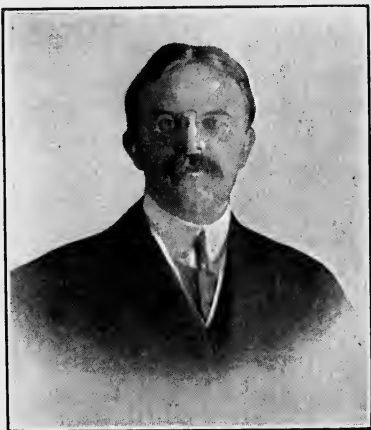

OSWALD GARRISON VILLARD

support of white friends who cannot understand why all Negroes do not think alike, and Trotter suffered unusual humiliation because he undertook by unlawful means to break up one of Washington's meetings in Boston.

This agitation has exhibited evidences of unusual vitality. It has given rise to widely circulated organs which stand for equal rights and equal opportunities—in short, for a square deal for all men regardless of race, color or previous condition of servitude. One of these, *The Crisis*, is now a self-supporting popular magazine with a circulation of almost 100,000. It is the organ of the National Association

for the Advancement of Colored People, a movement launched by the remnant of the abolition and reform element of the North, in connection with the militant Negroes. The personnel of the management of the Association is composed of some of the most prominent Negroes and white men



MOORFIELD STOREY, President of the National Association for the Advancement of Colored People

and women of the country. Among these are Oswald Garrison Villard, the grandson of William Lloyd Garrison; Moorfield Storey, one of the most prominent members of the American Bar; Joel E. Spingarn, a scholar of national reputation; Jane Addams, the social reformer; and A. H. Grimké, a fearless advocate of equality for all. While the Association and its promoters may have at times gone rather far in blaming Washington for his silence, it has nevertheless kept before the Ne-

groes the ideal which they must attain if they are to count as a significant factor in this country.

Washington's long silence as to the rights of the Negro, however, did not necessarily mean that he was in favor of the oppression of the race. He was aware of the fact that

An unjust criticism.

the mere agitation for political rights could not at that time be of much benefit to the race, and that their economic improvement, a thing fundamental in real progress, could easily be promoted without incurring the disapproval of the discordant elements in the South. He may be justly criticized for permitting himself to be drawn

into certain entanglements in which he of necessity had to make some blunders. As an educator, however, he stands out as the greatest of all Americans, the only man in the Western Hemisphere who has succeeded in effecting a revolution in education. A few centuries hence, when this country becomes sufficiently civilized to stand the truth about the Negro, history will record that Booker T. Washington, in trying to elevate his oppressed people, so admirably connected education with the practical things of life that he effected such a reform in the education of the world as to place himself in the class with Pestalozzi, Froebel and Herbart. The Negroes as a whole have little to say now against his educational policy, seeing that the white people have realized that industrial education is not only a good thing for the Negro but a blessing to the white man. The whites have accordingly proceeded to spend millions of dollars for buildings and equipment to secure these advantages to their youth. Washington's advocacy of industrial education, moreover, in spite of all that has been said, was not a death blow to higher education for the Negro. That movement has lived in spite of opposition, and Washington himself frequently stated that industrial education, as he emphasized it, was for the masses of the people who had to toil. He did not object to higher education, knowing that the race had to have men to lead it onward.

CHAPTER XVIII

ACHIEVEMENTS IN FREEDOM

DURING the years when the Negroes have had all sorts of advice as to how they might emerge from the muddle of controversy about the best solution of their problems, they have not all spent their time in academic discussion. Building upon the foundation that they made before the Civil War, the Negroes have developed into one of the most constructive elements in our economic system.¹ The census of 1910 shows that although the Negroes constitute about thirty per cent of the population of the South, more than half of the agricultural laborers of that section are Negroes. In the main, moreover, the Negroes are useful citizens, showing little tendency to become peddlers, agents, and impostors who make their living robbing the people. On the corners of the streets in some cities there may be found a few Negroes who are not disposed to work for a living, but these constitute a small fraction of one per cent of the Negro population of the United States.

The census reports will help us further to determine what the Negroes in this country have been doing. In 1910, 5,192,535, or 71 per cent, of the 7,317,922 Negroes between

¹ The statistics bearing on the progress of the Negro are found in the *United States Census Reports*. Other valuable facts may be obtained from Monroe N. Work's *Negro Year Book* and the files of *The Crisis*. There is also Mr. Henry E. Baker's informing article on *The Negro in the Field of Invention* (in the *Journal of Negro History*, II, 21-36). Dr. Thomas J. Jones's *Negro Education* in two volumes throws light on what has been going on in that field during the last half century.

the ages of 10 years and over were engaged in agriculture, forestry and animal husbandry. In the number employed in agriculture are included 893,370 farmers, planters and overseers; 218,972 were owners, 672,964 tenants, and 1,434 managers. Owners free of debt possessed 8,835,857 acres, owners having mortgaged farms had 4,011,491, and part owners 2,844,188. There were 12,876,308 acres operated by cash tenants; 13,691,494 by share tenants, and 349,779 by managers. This area of 42,279,510 acres will appear more realistic when one realizes that it is as large as New England, or Belgium and Holland combined.

The field in which most Negroes have been employed is agriculture, and next to that domestic and personal service. While in most of the unskilled occupations the Negroes constitute a larger percentage than their percentage of the entire population, the increasing number of skilled laborers has reduced the percentage of unskilled laborers from a very high mark to about seventy per cent. The standard of the unskilled laborer, moreover, has been raised, peonage has been gradually giving way to a system of wages, the intelligence of the workmen has increased, and the Negro laborers have become so dependable that despite the large influx of immigrants they have been able to withstand the competition. So much improvement in the Negro unskilled laborer has been made during the last generation that his increasing efficiency has rendered difficult the distinction between skilled and unskilled labor.

Recent statistics as to the number of Negroes employed at skilled labor will further emphasize this point. According to the census of 1910 there were among the males 12,401 brick and stone masons, 9,727 blacksmiths, 8,035 glaziers, painters and varnishers, 6,175 plasterers, 5,188 locomotive firemen, 4,802 stationary engineers, 3,296 machinists and millwrights, 2,304 coopers,

**Occupations
of Negroes.**

**Unskilled
labor.**

**Skilled
labor.**

The Negro In Our History

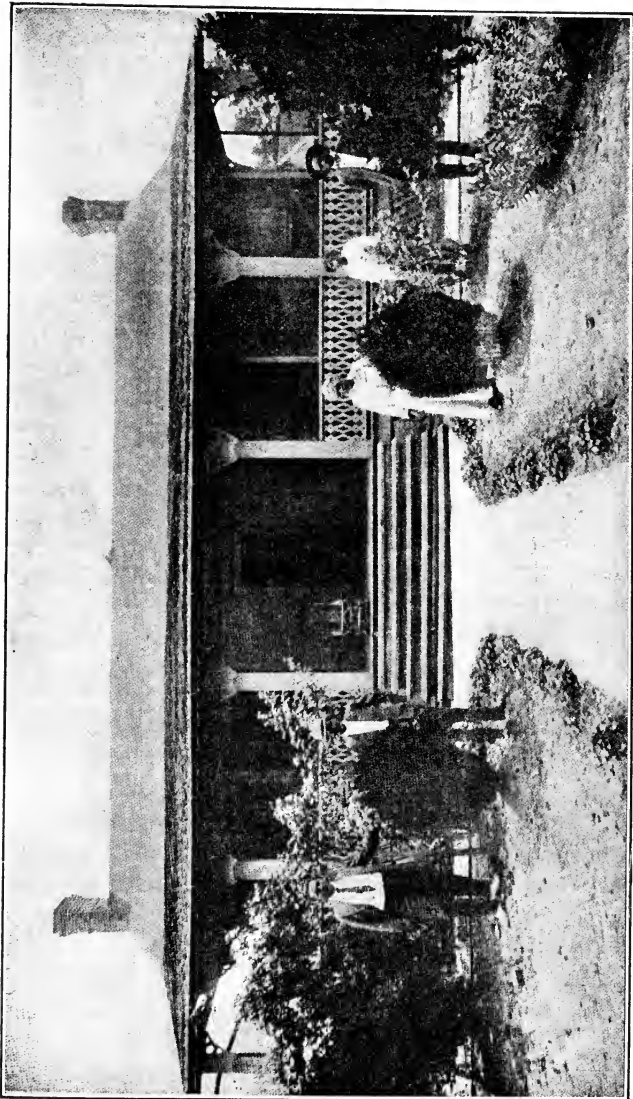

A NEGRO COUNTRY SEAT, the home of Scott Bond

2,285 plumbers, and gas and steam fitters, 2,156 molders, and 4,652 tailors. At the same time there were among the females, 38,148 dressmakers and seamstresses, 8,267 operators in cigar and tobacco factories, and 6,163 employed in general manufacturing.

Building upon these achievements in labor, the Negroes have towered higher and higher in the professions. In 1910



THE RESIDENCE OF MADAME C. J. WALKER

one Negro out of every 146 was engaged in some professional pursuit, whereas one white person in every 51 was thus engaged. The proportion of clergymen among Negroes exceeded that among the whites, but in the other cases the whites showed the excess of the ratio of population to professional workers. While it appears that professions among Negroes are still undermanned, a decided increase in this direction has been noted during the last generation. It means a great deal to be able after fifty years of freedom to produce 29,485 teachers,

5,606 musicians and teachers of music, 3,077 physicians and surgeons, 478 dentists, 798 lawyers, 123 chemists, 329 artists, sculptors and teachers of art, 247 authors, editors and reporters, 59 architects, and 237 civil engineers. That they have in half a century achieved enough in the professions to bring them within the range of comparison with the whites is striking evidence of the ability of the Negro to meet the test of competition.

This growing usefulness of the Negro in the new fields has meant a corresponding reduction in the numbers of those disposed to waste their time. The criminal class of the **Less crime.** Negroes in America, therefore, has decidedly improved, despite the reports to the contrary. These false alarms are based largely on unwarranted charges growing out of the convict lease system and the imposition of unjust fines for ordinary misdemeanors and such petty offenses as vagrancy. The attitude of the Negroes themselves toward maintaining the peace is well reflected in their efforts to better conditions by establishing law and order leagues working in coöperation with the local governments. To further this cause the Negroes have had the coöperation of the Southern Sociological Congress and the University Race Commission, which, although far from being unbiased, have done some good. These organizations are endeavoring to investigate the causes of the crimes of the whites against Negroes, as well as crimes of the latter. Both races have been much aided by the abolition of the liquor traffic.

The actual forces which have in general effected the improvement in the Negro race, however, have been strictly Negro organizations themselves. Chief among these are the Negro churches, social welfare agencies, and schools. In **Churches as factors.** 1906 the Negroes of white denominations had 6,210 churches with 514,571 communicants, 5,330 Sunday schools, 293,292 scholars, and property worth \$12,107,655. The independent Negro denominations had

33,220 churches with 3,789,898 communicants, 30,999 Sunday schools, 1,452,095 scholars, and property valued at \$45,191,422. These churches are in the main Baptist and Methodist. While the latter are divided into three groups, known as the African Methodist Episcopal Church, the African Methodist Episcopal Zion Church, and the Colored Methodist Episcopal Church, the Baptists had until the schism of 1916 only one national organization, exercising loose supervision over the whole denomination. Although smaller in numbers, however, these various Methodist churches have, by their well constructed organizations, been able to accomplish much in the extension of religion and education through their thirty-six well-informed bishops and enterprising general officers. The work of other denominations, like the Episcopalians, the Presbyterians, Congregationalists and the Catholics, has also been very effective in Negro uplift wherever they have secured a following.

Coöperating with these have come the 3,077 physicians, surgeons, and dentists, preachers of health, supplementing the work of the ministers of the gospel. They have been able to call the attention of entire communities to **Physicians.** the necessity of observing the laws of health and of making the community a decent place to live in. These well-trained men have therefore been able to supplement the work of the Anti-Tuberculosis League and the American Hygiene Association and to extend the operations of the annual school conferences held at Atlanta University, Hampton, and Tuskegee. So much good has been recently accomplished by the staff of workers lecturing to the soldiers in the camps on social hygiene that national bodies promoting health are now paying more attention to the problems of Negroes. As a result of this persistent struggle against ignorance, poverty and negligence, the mortality rate among Negroes has decreased and much improvement has been noted in their physique.

To do for the race some of the things which the church has not accomplished, social welfare work was undertaken among Negroes decades ago. The first colored Young Men's Christian Association was organized in Washington, D. C., **Work of the Y. M. C. A.** in 1853 by Anthony Bowen, a man of color; the second in Charleston, South Carolina, in 1866; and the third in New York City in 1867. The first colored Student Association was organized at Howard University in 1869. E. V. C. Cato, of the New York City Branch, attended the Montreal Convention in 1867 as the first Negro delegate thus to serve. In 1876 George D. Brown, ex-Confederate soldier, was appointed to supervise the Negro Branches of the Young Men's Christian Association throughout the country. In 1888, however, the lamented William A. Hunton, a man of color, who had been appointed as general secretary of the Negro Young Men's Christian Association of Norfolk, Virginia, was appointed to succeed Mr. Brown, and thereafter the work has been under the supervision of Negro secretaries.

The work was greatly extended with some difficulty, and was given much needed impetus by the accession to the ranks of enterprising secretaries laboring in many cities and in most Negro schools of the South. Interesting here **The growth.** and there persons who were prejudiced against the movement because of the failure to understand it, these gentlemen gradually worked their way into the very hearts of indifferent communities until in almost all of the large cities where Negroes are found in considerable numbers, business and professional men of both races, thanks to the noble example set by the large donations of Julius Rosenwald, have united to establish for Negroes branches of the Young Men's Christian Association, where they enjoy a comradeship and temporary home-like life which the transient of color could not theretofore find in those cities. Recently an effort has been made to provide for young

women in these centers the same facilities, and the success of the useful branches of the Young Women's Christian Association already established in New York, Washington, Louisville and St. Louis, has been sufficient encouragement to the authorities in charge to provide elsewhere similar facilities for women of color.

As a result of the work of these agencies the home life of the Negroes has been decidedly improved. Every Negro, of course, has not heeded the advice of his friends, and the fact that some have lagged behind while others have gone forward makes it no longer possible to speak of all Negroes as belonging to two classes, as it was before the Civil War when they were known as slaves and free persons of color. **Improvements in homes.** Negro homes now show the same difference in standards as found among the whites. The majority of Negroes have advanced beyond the point of being satisfied with a one-roomed hut conspicuous by its lack of ordinary comforts. They are buying land and building houses of several rooms. An effort is made to decorate the walls and supply the home with adequate furniture. Negro children attending school read the latest books, newspapers, and magazines. Where the evidence of such progress is not manifest it is possible in most cases to show that, because of economic conditions, the Negroes concerned have been too much handicapped by poverty to improve their situation as they would like. Recent improvements in their economic situation, however, have made these conditions exceptions to the rule.

For the remaking of Negroes most credit must be given to the schools at work among them. The teacher has made the school, the school has figured largely in the making of the home, and the home has produced a new **The Efforts of schools.** civilization. While, despite the efforts of kindly disposed educators like Ruffner, Curry, and Dillard, the facilities for education offered Negroes in the public

schools of the South have been unusually meager, hardly extending beyond that of teaching them to read and write, there have been offered in schools maintained in the South by northern philanthropy opportunities for so much enlightenment that teachers going out from these institutions have come to their people like missionaries inspired to preach a new gospel to the lowly. Lincoln and Wilberforce



JULIUS ROSENWALD

Universities set a high standard for the education of the Negroes prior to the Civil War, and Howard University, under its distinguished founder, General O. O. Howard, undertook to equip for leadership a number of youths of color so to toil for the enlightenment of their people as to mark a new epoch in their progress. A large number of other philanthropists having the same ideals as the founders of these institu-

tions, established others, like Fisk, Atlanta, Tougaloo, Talladega, Morehouse, Livingstone, Knoxville, and Straight.

Industrial schools.

Then came Hampton, Tuskegee and the like, directing attention primarily to the education of the masses in things fundamental so as to enable the youth to begin with life where he is and to make of it what his opportunities will permit.

Meeting thus in a way almost every need for Negro education, offering facilities for training of all sorts, the Negro schools have been very successful because of the impetus given them by such philanthropists as William H. Baldwin,

Jr., Robert C. Ogden, H. H. Rogers, John D. Rockefeller, Andrew Carnegie, and Julius Rosenwald, through their liberal contributions to the establishment and the development of various institutions. While education may at times have been ill assorted, in that persons have without giving due consideration to their capacity and opportunities wasted time undertaking to master things to which they were ill adapted and which they would never have to do, the readjustment has worked out in such a way that Negroes, like the whites, now have opportunities to equip themselves for whatever they feel disposed to do, and in life they have exhibited the same mental endowment found among the people of all other races.

The good work of these institutions has been effective in putting the Negro on his feet, so to speak, enabling the Negro to do for himself what the thousands of sympathetic and benevolent whites of the missionary spirit had to do for the Negroes in leaving their homes in the North. Out of these schools have come thousands of Negroes of scholarly tendencies who have, in devoting their time and means to the study of educational problems and school administration, equipped themselves for leadership in education in the South. It has for some time been a matter of much regret that white persons in

**Aid from
philanthro-
pists.**

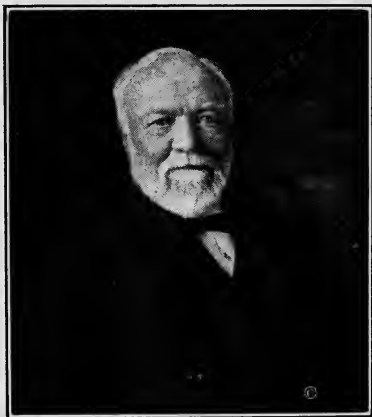

ANDREW CARNEGIE. The donor of \$600,000 to Tuskegee. The first philanthropist to set the example of giving large sums of money for the elevation and development of the Negro race.

Copyright by Marceau.

**Trained to
leadership.**

The Negro In Our History



JOHN D. ROCKEFELLER AND HIS SON. Through appropriations of the General Education Board and the Laura Spelman Rockefeller Memorial large sums have come from these philanthropists to agencies engaged in the uplift and the education of the Negro.

Copyright by Underwood & Underwood.

charge of schools maintained by philanthropy in the South have failed to recognize this ability of the Negro and still adhere to the policy of restricting them to subordinate positions. Negroes have borne it grievously that they have had to contend with white persons who feel that whenever a Negro is given a position of responsibility he needs careful

watching or supervision by some white man that it may be done in keeping with some established policy.

The Negroes have not only learned lessons in religion, education and health, **Progress in business.** but have shown

unusual progress in the business world. They have accumulated so much property in the rural districts that they constitute a desirable class of small farmers.

In the cities in which recently there has taken place the concentra-



R. R. MOTON, the Principal of Tuskegee

tion of large numbers of Negroes, enterprising men of color are gradually taking over business formerly monopolized by whites. Near a Negro church you will find an undertaker of color. In almost any Negro urban community there is a successful real estate dealer, a reliable contractor, an insurance office, and sometimes a bank. So popular has it become for Negroes to deal with their own people, that white men owning business in Negro sections have learned to employ considerable Negro help.

The Negro in business, however, is not a new thing. The point to be noted here is the unusual progress of the race in this field during recent years. It is more **Unusual achievements.** than encouraging, moreover, to observe how easily the Negroes have learned the lesson of pooling their

efforts in larger enterprises. To promote the economic progress of the race, Negroes have been wise enough to organize several efficient agencies. The first of these to attain importance was the National Business League founded by Dr. Booker T. Washington. There are also the National Negro Bankers' Association, the National Association of Funeral Directors and the National Negro Retail Merchants' Association. Negro fraternal organizations, although established for social purposes, have in recent years taken on a business aspect in providing for the purchase of property and the insurance of the lives of their members. In some parts of the South the Negroes use no other insurance, and the managers of this work constitute in reality an industrial insurance company. The Negroes have about fifty banks and ten insurance companies, three of which are regular old line life insurance companies. In 1910, 3,208 Negroes were employed in banking and brokerage, 2,604 in insurance, and 1,095 in real estate.

Among these captains of industry thus pressing forward should be mentioned John W. Lewis, President of the Industrial Savings Bank and the Whitelaw Apartment House Corporation of Washington; Samuel W. **Captains of industry.** Rutherford, secretary of the National Benefit Association of the same city; Isaiah T. Montgomery, the capitalist of Mound Bayou, Mississippi; John Merrick, founder of the North Carolina Mutual and Provident Association; R. L. Smith, the organizer of the Farmers' Improvement Society of Texas; Heman E. Perry, President of the Standard Life Insurance Company of Atlanta; and the late Madame C. J. Walker, the manufacturer of toilet articles, out of which she accumulated more than a million dollars worth of property. The Negroes in the United States now own property worth more than a billion dollars.

In the midst of the busy bustle and the economic de-

velopment of the United States since the Civil War the Negro has not only demonstrated his ability to accumulate a portion of the world's goods, but has by his inventive genius contributed much toward the economic progress of the country. As to exactly how many Negroes have appeared in the field of invention we are still in doubt. The United States Patent Office has not in all cases kept a record as to the race of the applicants. While in many instances the racial connection has been easily determined, an investigation has shown that many inventors of color have not disclosed facts to this effect because the value of the invention might thereby be depreciated. By correspondence with patent attorneys and the inventors themselves it has been established as a fact that there are in the United States Patent Office a record of 1,500 inventions made by Negroes. This number, no doubt, is only a fraction of those which have been actually assigned to persons of color.

Some of these inventions have been remarkable. Probably the most significant one of them is that of a machine for lasting shoes invented by Jan E. Matzeliger, a Negro born in Dutch Guiana in 1852. Early in his youth Matzeliger came to this country and served as an apprentice at the cobbler's trade in Philadelphia and in Lynn, Massachusetts. Undergoing unusual hardships which undermined his health, Matzeliger applied his brain to working out a labor-saving device by which his trade might be relieved from drudgery. He invented, therefore, a lasting machine which adjusted the shoe, arranged the leather over the sole, and drove in the nails. Matzeliger died in 1889, in his thirty-seventh year, before he could realize the value of his invention. The patent was bought by Sydney W. Winslow, who, upon the advantages derived from this machine, established the well-known United Shoe Machinery Company, which absorbed over 40 smaller corporations.

This company is operated now with a capital stock of more than \$20,000,000, employing 5,000 operators in factories covering more than twenty acres of ground. Within the twenty years from the time of its incorporation its product increased from \$220,000 to \$242,631,000 and the shoes exported increased from 1,000,000 to 11,000,000. As a result the cost of shoes decreased fifty per cent, the wages of the operators decidedly increased, the working hours diminished, and laboring conditions improved.

Some other inventions of Negroes of less consequence were of much value and deserve mention. J. H. Dickinson and S. L. Dickinson, both of New Jersey, have been granted **Valuable inventions.** a dozen patents for mechanical appliances used in player piano machinery. W. B. Purvis of Philadelphia has accumulated much wealth by his inventions of machinery for making paper bags, most of these having been sold to the Union Paper Bag Company of New York. A. B. Albert, a native of Louisiana, invented a few years ago a cotton picking machine. Charles V. Richey of Washington, D. C., invented and patented several devices for registering calls and detecting the unauthorized use of the telephone. Shelby J. Davidson invented a mechanical tabulator or adding machine; Robert A. Pelham, a pasting machine; and Andrew F. Hilyer, two hot-air register attachments. Benjamin F. Jackson of Massachusetts invented a heat apparatus, a gas burner, an electrotypers' furnace, a steam boiler, a trolley wheel controller, a tank signal, and a hydrocarbon burner system. Frank J. Ferrell of New York obtained about a dozen patents for improvements in valves for steam engines. George W. Murray, a former member of Congress from South Carolina, patented eight inventions of agricultural implements. Henry Kreamer of New York made seven different inventions in steam traps. William Douglass of Arkansas secured six patents for inventions of harvesting machinery. James

Achievements In Freedom

J. E. MATZELIGER

LASTING MACHINE

No. 274,207.

PATENTED MAR. 20, 1883

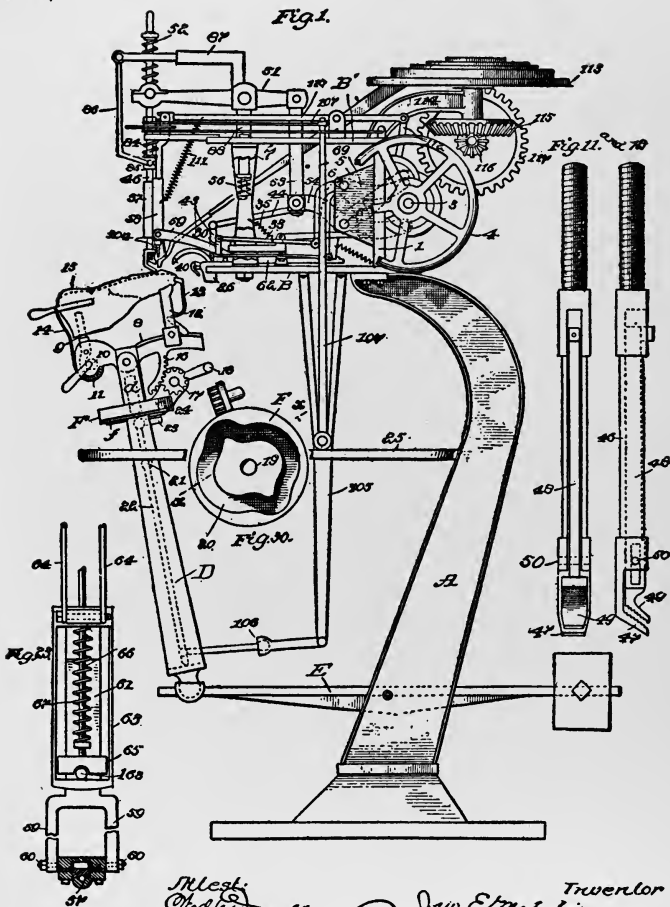

Inventor
J. E. Matzelliger
by Edward
1883

Witness
J. E. Matzelliger
by Edward
1883

AN ILLUSTRATION SHOWING THE MODELS MADE BY MATZELIGER TO ILLUSTRATE HIS INVENTIONS IN SHOE MACHINES.

Doyle of Pittsburgh devised the automatic serving system so as to dispense with the use of waiters in cafes.

Fred J. Lowden, known to fame as one of the Fisk Jubilee Singers, patented in 1893 a fastener for the meeting rails of sashes, and a key fastener the following year. J. L. Pickering of Haiti, James Smith of California, W. G. Madison of Iowa, and H. E. Hooter of Missouri, have been granted patents for inventions in airships. No less significant, moreover, was the patent, in 1897, of Andrew J. Beard, of Alabama, for an automatic car-coupling device, sold to a New York car company for more than \$50,000. William H. Johnson of Texas invented a successful device for overcoming dead center in motion, one for a compound engine and another for a water boiler. While keeping a hotel in Boston, Joseph Lee patented three inventions for kneading dough. Brinay Smart of Tennessee invented a number of reverse valve gears. J. W. Benton of Kentucky invented a derrick for hoisting heavy weights. John T. Parker invented screws for tobacco presses with which he established a thriving business as the Ripley Foundry and Machine Company of Ripley, Ohio.

The most useful inventor with a career extending into the twentieth century, however, was Granville T. Woods, who doubtless surpassed most men in his field in the number and variety of his devices. He began in Cincinnati, Ohio, in 1884, where he obtained his first patent on a steam boiler furnace. Then came an amusement machine apparatus in 1880, an incubator in 1900, and electrical air brakes in 1902, 1903, and 1905. He then directed his attention to telegraphy, producing several patents for transmitting messages between moving trains, and also a number of transmitters. He thereafter invented fifteen appliances having to do with electrical railways and a number of others for electrical control and distribution.

To further his interests he organized the Woods Electrical Company, which took over by assignment all of his early patents. As in the course of time, however, he found a larger market for his devices with the more prosperous corporations in the United States, the records of the patent office show the assignment of a large number of his inventions to the General Electric Company of New York, the Westinghouse Air Brake Company of Pennsylvania, the American Bell Telephone Company of Boston, and the American Engineering Company of New York. During this period of his larger usefulness he had the coöperation of his brother, Lyates Woods, who himself invented a number of such appliances of considerable commercial value.



GRANVILLE T. WOODS

Another inventor of consequence was Elijah J. McCoy. He was unique in that he was the first man to direct attention to the need for facilitating the lubrication of machinery. **Elijah J. McCoy.** His first invention was patented in 1872 as a lubricating cup. From that day his fame as an inventor of this useful appliance went throughout this country and abroad. In responding to the need for still further improvements in this work, he patented about fifty different inventions having to do with the lubricating of machinery. His lubricating cup became of general use on the leading railroads in the United States and abroad and on the vessels on the high seas. In his work, however, Mr. McCoy was not restricted to lubricating machinery. He patented a variety of devices for other purposes, and he was long active in the production of other mechanical appliances in demand in the industrial world.

The achievements of the Negroes in this field become much worthier of mention when one takes into consideration the hard problems of the inventor of color. In this country it has not been a very easy matter for white men with ample protection of the law to secure to themselves by patents the full enjoyment of the fruits of their own labor. The achievements of Eli Whitney and Robert Fulton are cases in evidence. Henry A. Bowman, a Negro inventor of Worcester, Massachusetts, therefore, found himself facing the same difficulty. After he had established a thriving business on the basis of his invention of a new method of making flags, he discovered that a New York firm was outstripping him by using his invention. As he was unable to hire competent attorneys to protect his interests, he was soon compelled to abandon his business. The experience of E. A. Robinson of Chicago is another case in evidence. He invented a number of devices, such as the casting composite for car wheels, a trolley wheel, a railway switch and a rail. His patents, however, were infringed upon by two large corporations, the American Car and Foundry Company and the Chicago City Railway Company. To restrain these corporations from appropriating his property to their use, he instituted proceedings in the local courts and finally in the Supreme Court of the United States, but hitherto he has been unable to have his patent protected.

Exhibiting this same sort of genius ever manifesting itself despite difficulties, Negroes have shown in other fields evidences of unusual attainment. In music the world has seen the lowly life and higher aspirations of the Negro in J. W. and F. W. Work, Will Marion Cook, Nathaniel Dett, and Harry Burleigh, following in the footsteps of Samuel Coleridge Taylor. In sculpture the race has been well represented by Meta Vaux Warrick Fuller, who won fame by her first work in clay

**Difficulties
of the
inventor.**

**The Negro
in music.**

in the Philadelphia School of Industrial Art. She studied in Paris, where she attracted the attention of the great sculptor, Rodin. In 1893 she exhibited the highly prized model of art, *The Wretched*, her masterpiece. She has since added some other works, *The Dancing Girl*, *The Wrestlers*, and *Carrying the Dead Body*. In the same field has also appeared Mrs. May Howard Jackson, whose works have elicited honorable mention in many circles. E. M. Bannister, William A. Harper, and William E. Scott have attracted considerable attention by their paintings.

The most distinguished Negro in the field of art, however, is Henry O. Tanner, who, with the white artist, Sargent, represents the best America has produced in painting. He had little encouragement in this field, but **Henry O. Tanner.** early attracted attention by *The Bagpipe Lesson*, portraying a workman sitting on a wheelbarrow observing the efforts of a youth on a musical instrument. Lacking in this country the atmosphere conducive to the development of the best in man, Mr. Tanner went to the city of Paris in 1891 where, under the instruction of Jean Paul Laurens and Benjamin Constant, he mastered the principles of art. There, in contact with men in his own sphere, he has developed into one of the greatest artists of his time.

His first painting of value was exhibited in 1894. The following year he completed *The Young Sabot Maker*, but it was not until 1896 that with the encouragement given him by the great artist Gérôme Mr. Tanner won recognition as a painter. In 1897, however, his *Raising of Lazarus* attracted so much attention far and wide that thereafter there was little doubt in the circles of art as to the greatness of this man. This picture was awarded the gold medal by the French government and placed in the Louvre. In 1898 he presented to the public *The Annunciation* at the Academy of Fine Arts in Philadelphia, eliciting

ing unusually favorable comment. His *Judas*, presented to the public in 1899, was bought by the Carnegie Institute of Pittsburgh. That same year *Nicodemus*, awarded the Walter Lippincott prize of \$300, was purchased by the Pennsylvania Academy of Fine Arts. For his *Daniel in the Lion's Den* he was awarded second class medals at the Universal Exposition in Paris in 1900, at the Pan-American Exposition in 1901, and at the St. Louis Exposition in 1904. In 1906 his *The Disciples at Emmaus* was awarded the the

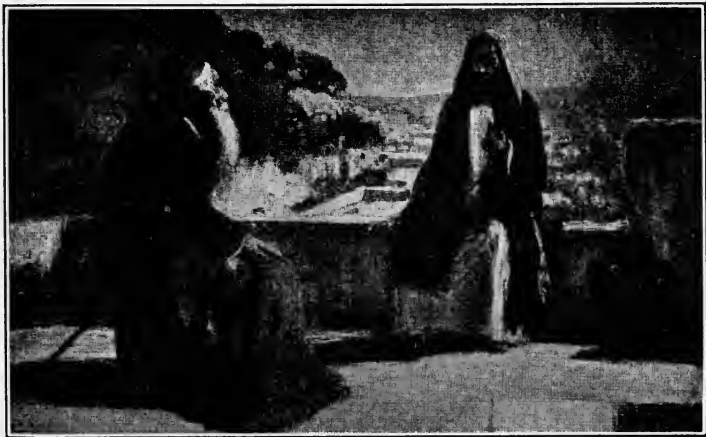

H. O. TANNER'S *Christ and Nicodemus*

second gold medal and purchased by the French Government. That same year his *The Disciples at the Tomb* was declared the best painting at the annual exhibition of art in Chicago and was awarded the N. W. Harris prize of \$300. In 1908 appeared *The Wise and Foolish Virgins*, which was characterized as a masterpiece of a sincere artist.

As a painter, Mr. Tanner has directed his attention largely to religious and lowly life, as evidenced by the names of his paintings. He no doubt owes this attitude to the fact that he is the son of a bishop of the African Methodist

Episcopal Church, and early in life was encouraged to apply himself to theology. As an artist his productions have a reverent atmosphere, and his pictures are clean-cut and luminous. In his paintings there are subtle power, purity of line, and thorough charm, with sentiment prevailing over technique. While the shades are luminous, the coloring is neither heavy nor muddy. "He always brings out of all his work," says one, "an admirable dramatic sentiment given full value and fully expressed."

In the field of literature the Negroes are sometimes considered as beginners, but much progress in this field is evident. Kelly Miller, W. E. B. DuBois and William Pickens have done well in controversial literature. **In literature.** George W. Williams, John W. Cromwell and Booker T. Washington have made contributions to history. Following in the wake of Jupiter Hammon, Phyllis Wheatley and Frances E. W. Harper, writers of interesting verse, Paul Laurence Dunbar came before the public in the early nineties as a man endowed with the unusual gift of interpreting the lowly life of the Negro. As an elevator boy in a hotel, writing a few lines in dialect, he himself did not realize his poetic genius. Succeeding, however, in having a few of these published in daily papers and magazines, he attracted attention. It was not long before William Dean Howells, a contemporary, became interested in his works and proclaimed him to the world as a poet worthy of the consideration given Whittier, Lowell and Longfellow. **The rise of Dunbar.** Dunbar had fortunately reached that unusual stage in the development of a belated people of having his education react upon his environment. He saw the Negro as he is, saw something beneath the surface of his mere brogue, in fact, saw a philosophy for which the world wanted an interpretation. This interpretation came in his first book, *Oak and Ivy*, and was still better exhibited in his second work, *Majors and Minors*, appearing in 1895.

Very soon then we hear of him such comments as that coming from Richard Watson Gilder, saying that Dunbar is the first black man to feel the life of the Negro esthetically and to express it lyrically.

Dunbar made an attempt at novel writing, as appears in his *The Uncalled*. This was a character study upon which

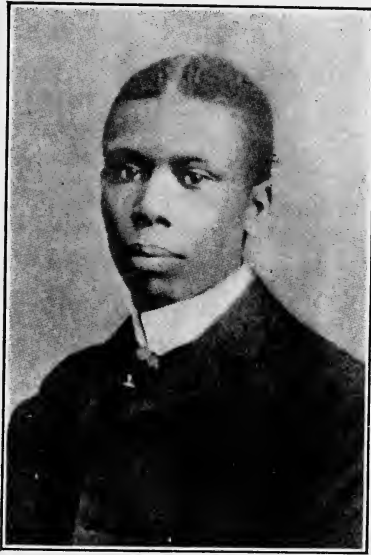

PAUL LAURENCE DUNBAR

fortunately his reputation as a literary man does not rest, for it does not come up to the standard of his verse. Unstinted praise awaited him upon his publication of *Lyrics of Lowly Life*, *Folks from Dixie*, *Lyrics of the Hearthside*, *Poems of Cabin and Field*, *The Strength of Gideon*, *The Love of Landry*, *The Fanatics*, *The Sport of the Gods*, *Lyrics of Love and Laughter* and *Candle Lighting Time*. Some of the popular poems in this collection which are worthy of special mention are *When Malindy Sings*,

When the Co'n Pone's Hot, *The Party* and *The Poet and his Song*.

His success as a literary man was due to his originality. While there had appeared from time to time scores of whites and blacks who had undertaken to write verse in Negro dialect, Dunbar was the first to put into it such thought and make of it such a portraiture of the feeling and the aspirations of the Negroes as to give his work the stamp of originality. While he was always humorous, his

poetry showed deep pathos and sympathy. With no problems to solve and no peculiar type of character to represent he went into the Negro life, saw it as it was, and emerged portraying it with living characters exhibiting the elasticity, spirit, tone, and naturalness in the life about him.

In life he was respected and known throughout this country and abroad. In 1897 he visited England, where because of his fame as a poet he was received with marked honor. Upon returning to this country his literary engagements became such that he could devote himself entirely to work in his field. His health early began to decline, however, and he died at the age of thirty-four at his home in Dayton, Ohio, which, thanks to the interest of sympathetic persons of both races, is now maintained as a monument to remain as a museum in honor of the poet, Paul Laurence Dunbar.

Since the days of Dunbar a number of other Negro writers of prominence have considerably interested the public. Among these should be mentioned Angelina W. Grimké, a woman of poetic insight; Benjamin Other writers. Brawley, an author of many interests; Jessie R. Fauset, a writer of varying purpose; Georgia Douglas Johnson, whose interesting poems have recently appeared as *The Heart of a Woman*; Leslie Pinkney Hill, distinguished by his *Wings of Oppression*; Joseph Seaman Cotter, known to the public through his poems contributed to various magazines and his collection entitled the *Band of Gideon*; and James Weldon Johnson, whose invaluable works are collected in the volume, *Fifty Years and Other Poems*. These authors are at their best in writing poems which have no bearing on the life of the Negro. In this field they have exhibited evidences of the thought, feeling and imagination found in the best literature. In taking up Negro life, however, they have not reached the standard of Dunbar. Their difficulty has been that because of sufferings from social

proscription in the white men's world they have faced their task with a problem to solve and, unlike Paul Laurence Dunbar, who went into life and merely portrayed what he saw, they prejudice their readers against them by a premature introduction to an unpleasant atmosphere.

The most remarkable writer of Negro blood since Dunbar is William Stanley Braithwaite, who as a writer is not a Negro. Although realizing the fact that the race has obstacles to surmount, that it is in a great struggle, and that the battle is being hard fought, Mr. Braithwaite has by his literary production and criticism won much consideration for the Negroes, not by singing of their woes, but by demonstrating that the Negro intellect is capable of the same achievements as that of the whites. In his poems, his annual publication, the *Anthology of Magazine Verse*, and his numerous literary criticisms appearing from time to time in the leading publications of this country, Mr. Braithwaite, although a man of African blood, is accepted as one of the foremost literary critics of our day.

CHAPTER XIX

THE NEGRO IN THE WORLD WAR

WHILE the Negroes were suffering from persecution in the South and economic proscription in the North, the world plunged almost unexpectedly into a universal struggle which materially affected the interests of the blacks.¹ The heir-presumptive to the Austro-Hungarian throne was shot at Serajevo June 28, 1914. Blaming the Serbs for this crime, the Austrian government sent Serbia an ultimatum demanding that the offenders be brought to trial by a tribunal in which Austria should be represented. Serbia refused to yield to these demands and was supported by Russia in this position; but Germany upheld Austria, feeling that if such an act passed without punishment, it would soon be impossible for the crowned heads of Europe to maintain their empires. England, France, and Italy recommended that the matter be adjusted by arbitration, but Germany, contending that mobilization of the Russian army was in reality a declaration of war against her, declared war on Russia the first of August and on France two days later. England sympathized with France, to which she was attached by various ties, and accordingly entered the war against Germany.

¹ The history of the World War has not yet been written. There have appeared several subscription volumes for the purpose of making money rather than to publish the whole truth, and they have been extensively sold. As to the rôle of the Negro in this drama there is but scant reliable information. Emmett J. Scott has written a popular account of the achievements of the Negroes in this struggle, but it is hoped that this may soon be followed by a scientific treatise.

When Germany showed such disregard of her treaty obligations as to invade Belgium, a neutral country, she lost the sympathy of most European and American countries, many of which finally joined the allies to curb the power of the Hohenzollerns.

As the United States, although deeply sympathizing with the struggle against autocracy, did not deem the interference with our commerce and even the sinking of our **Prosperity.** neutral ships sufficient cause for intervention, this country entered at once upon an unprecedented period of commercial prosperity in becoming the source of supply for almost everything needed by the numerous nations involved in the war. Industries, formerly in a struggling state, received an unusual impetus; new enterprises sprang up in a day; and persons formerly living merely above want multiplied their wealth by fortunate investments. The aggressions of Germany upon our commerce resulting in the death of our citizens upon ships destroyed on the high seas became so numerous, however, that thousands of Americans, led by Theodore Roosevelt, insisted upon a declaration of war against Germany. But our trade with the Allies was so lucrative that it was difficult to convert a majority of the people of the country to the belief that it would be better for us to disturb the era of commercial prosperity to go to war for the mere principle that Germany wronged us in trying to break up our lawful commerce with the belligerents in Europe.

This continued prosperity brought on a new day for the laboring man and consequently a period of economic advancement for the Negro. The million of immigrants annually reaching our shores were cut off from **A new day for labor.** this country by the war. Labor in the United States then soon proved to be inadequate to supply the demand. Wages in the industrial centers of the North and West were increased to attract white men, but a sufficient

number of them could not be found in this country, so great was the demand in the industrial centers, the plants, and cantonments, making preparations for war. Departing then from the time-honored custom in the North, the needy employers began to bid for Negro labor of the South. All Negroes who came seeking unskilled labor were hired, and occasionally skilled workmen of color found employment. But the Negroes of the South were not merely invited; they were sent for. Those who first ventured North to find employment wrote back for their friends, and when this method failed to supply the demand, labor agents were sent for that purpose wherever they could find men; but the Mississippi Valley, for several reasons, proved to be the most favorable section. Through this valley conditions had at times become unsettled on account of the periodical inundations of the Mississippi, and the Negroes in those lowlands, usually the greatest sufferers, welcomed the opportunity to go to a safer and more congenial part. Throughout the Gulf States, however, where the boll weevil had for years made depredations on the cotton crop, Negroes were also inclined to move out to a section in which their economic progress might be assured. In short, the call from the North came at the time the Negroes were ready and willing to go.

Negro labor
in demand.

It may seem a little strange that Negroes who had for years complained of intolerable persecution in the South never made any strenuous efforts to leave until offered economic advantages in the North. Such a course was inevitable, however, for, intolerable as conditions were in the South, the Negro had to live somewhere and he could not do so in the North because of the monopoly of labor maintained there by the hostile trades unions. In this more recent movement, instead of making his way to the North where among unfriendly people he would have to eke out an existence as

Economic
advantages
in the North.

The Negro In Our History

PERCENTAGE NEGRO IN THE POPULATION

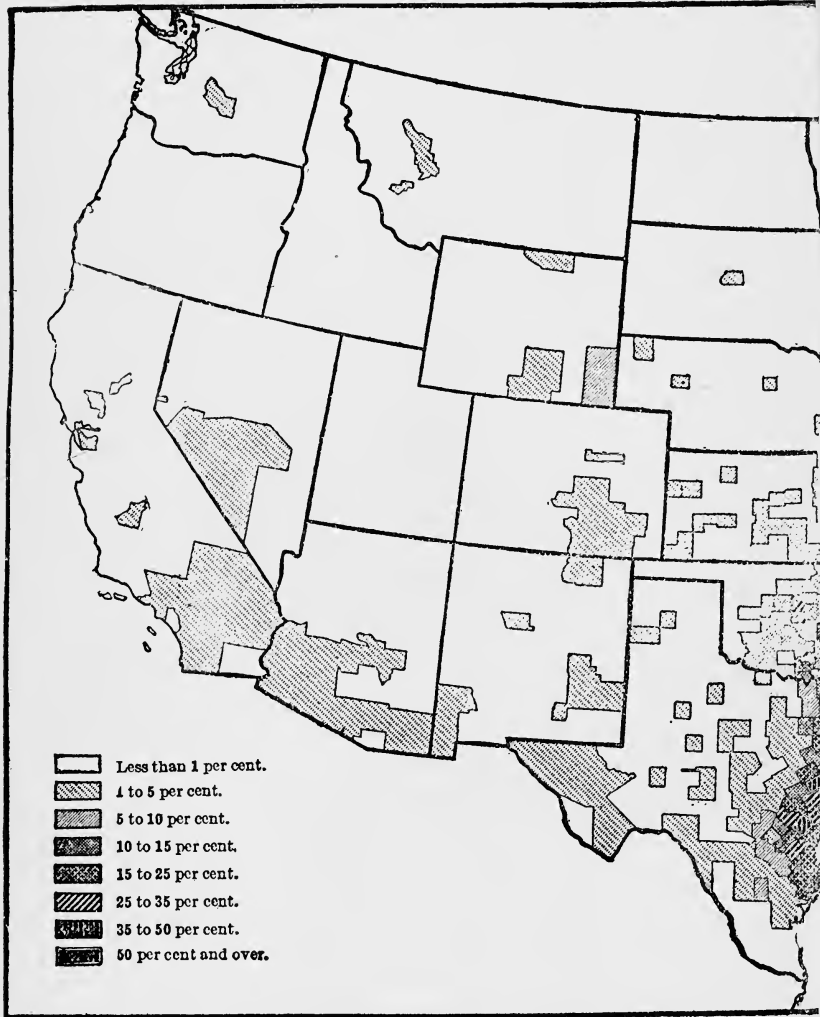

The Negro In the World War

OF THE UNITED STATES, BY COUNTIES· 1910.



a menial, he was invited to come to these industrial centers where friends and employment awaited him. History, moreover, does not show that large numbers of persons have migrated because of persecution. If not assured of an equally good economic foundation elsewhere, the majority of those persecuted have decided in the final analysis to bear the ills they have rather than fly to those they know not of.

The oppression of the Negroes in the South, however, was also a cause of the exodus, though not the dominant one. When men from afar came to tell the Negroes of a way of **Oppression,** escape to a peaceful and law-abiding land, **a cause.** they were received as spies returning from the inspection of a promised land. While the many were moved by the chance to amass fabulous sums, they all sighed with relief at the thought that they could at last go to a country where they could educate their children, protect their families from insult, and enjoy the fruits of their labor. They had pleasant recollections of the days when Negroes wielded political power, and the dream of again coming into their own was a strong motive impelling many to leave the South. Negro leaders primarily interested in securing to the race the full enjoyment of its rights rejoiced that they were going North, while the conservative, sycophantic toady classes advised them to remain in the service of their employers in the South.

In the North, however, although the Negroes readily entered upon the enjoyment of many privileges denied them in the South, they have here and there been brought into **Troubles in** competition with the radical white laboring **the North.** element which at Chester, Youngstown, and East St. Louis precipitated riots in trying to get rid of Negro labor. At East St. Louis in July, 1917, Negroes long harassed by this element finally became the object of onslaughts by the whites. They were overcome by the

mob, which was supported by the silence of the militia sent to maintain order and even outwardly by certain of its members, who permitted individuals to take their guns to drive the Negroes into their congested quarters, where they massacred and burned 125. The administration of justice in this northern State seemed no better than that in the South; for although the whites were the aggressors in the

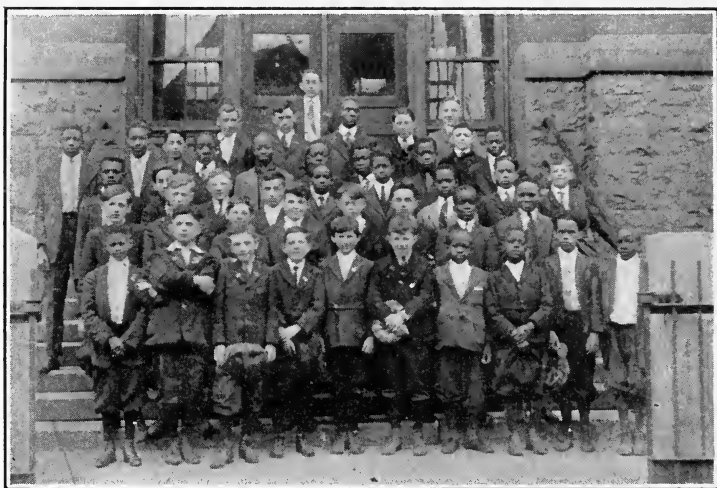

A RESULT OF THE MIGRATION. A Negro teacher with pupils of both races.

riot, the court inflicted more punishment on the Negroes than on the whites. One Negro was sentenced to life imprisonment but later acquitted. Ten other Negroes were to serve fourteen years, whereas four white men were imprisoned for from fourteen to fifteen years, five for five years, eleven for less than one year; eighteen were fined, and seventeen acquitted.

These outbreaks, of course, justified the predictions of

southern employers that the Negroes would not be welcomed in the North and strengthened certain seriously thinking Negroes in believing that the prosperity of the Negro in the industrial centers was merely temporary and that the trades unions, especially when strengthened by the immigrants from Europe after the war, would eventually force the Negroes out of employment after having severed the ties which bound them to the South. Other Negroes had little fear from the immigrants. Believing that the depopulation of Europe during this war will render a large immigration from that quarter an impossibility, others urged the Negroes to continue their coming North in spite of all conflicts and difficulties, seeing that they are now migrating in such numbers as to be materially helpful and to wield economic and political power.

Knowing that the South was losing the only sort of labor it can use in its exploiting system, employers of that section considered the exodus a calamity. They, therefore, took steps to impede and if possible to stop the movement. Moral suasion was first used. Negroes were told of the horrors of the North and especially of the hard winters. When letters to Negroes from friends who were easily braving these hardships reached the South, another sort of argument was necessary. Labor agents were first handicapped by requiring of them a high license; they were then by special ordinances prohibited from inducing Negroes to leave, and finally driven out of the South. As the mail proved to be almost as good an avenue for reaching the prospective migrant, those seeking to prevent the exodus found their efforts still futile. Negroes going North were then driven from the railway stations, taken from trains, and imprisoned on false charges to delay or prevent their departure from southern cities, but the Negroes continued to go North. The movement was not checked until after the

intervention of the United States in the war, when the administration spent so much money in the South while hurrying the preparation for war that wages so rapidly increased and work became so general that it was unnecessary for the Negroes to go North to improve their economic condition.

The final intervention of the United States in the World War marked another epoch in the history of the Negro in this country. In the first place few people in America were anxious to go to the front, although a majority of our citizens felt that the Hohenzollern autocracy should be destroyed. Men had to be converted to the war. German spies had long been abroad in this country, and millions, because of their German descent, felt bitter toward the United States for going to the aid of the Allies. There was then much apprehension as to the attitude of the Negroes, as they throughout this country had been treated as pariahs unprepared for the full measure of that democracy for which Woodrow Wilson desired to fight in Europe that the world might be a decent place to live in. As a matter of fact German spies did approach Negroes, and a few of them expressed themselves as being in sympathy with Germany. A still larger number boldly advocated making this country a decent place for the Negroes before taking Negroes to Europe to secure to the oppressed there privileges which the blacks could not enjoy at home.

The intervention of the United States.

German spies.

In thinking that the Negro would prove disloyal to the United States, however, the white man showed that he did not understand the race. The Negroes of this country love their native soil and will readily die, if necessary, to defend it. However, they do not love the reactionaries, who during the last fifty years of their control of the Federal Government have failed to live up to their oath to carry out the Constitution of the

The Negroes loyal.

United States, which guarantees to the Negroes the enjoyment of every right, immunity, and privilege, found in the most liberal democracy on earth. The Negroes will continue to be loyal to their country, with the hope that the degraded elements in control may become sufficiently civilized to abandon medieval methods for government based on liberty, equality, and fraternity. As the principle is worth fighting for, and as the struggle for it must not be hopeless in view of the interest occasionally shown in the man far down, the Negroes would not permit their dispositions to sour; they forgot their wrongs and offered themselves to fight the battles of humanity.

The reactionary class, however, although ready to brand the Negroes with suspicion and to prosecute them for dis-

**Reactionaries
against
Negroes.**

loyalty, urged the government not to recruit Negroes. The Negroes, according to the whites of this attitude, constituted an inferior class which should not participate in the struggle of white men. Many Southerners, moreover, who, in their faulty judgment, have solved forever the race problem by depriving Negroes of social, political and civic rights, considered it alarming to train them in the arts of war; for men who have waded through blood to victory are not easily intimidated into subjection to the insult and outrage legalized in the backward districts. The efforts of the reactionaries were futile, however, and the Negroes were drawn into the army in much larger numbers than they should have been. Although constituting one-tenth of the population, the Negro element furnished thirteen per cent of the soldiers called to the colors. At the same time the European nations had not sufficient prejudice to hesitate as did Americans in deciding the question of employing Negro troops. There were 280,000 Senegales who had helped to repel the Germans on the Ourcq and the Marne, 30,000 Congolese, and about 20,000 from the British West Indies,

who also did their part in saving France from autocracy.

When the American Negro was finally decided upon as desirable for the army, the same reactionaries in control of the Federal Government endeavored to restrict them in the service. Negroes had to register under methods of discrimination, that they might not be confused with the whites. No provision in the beginning was made for training Negro officers, and southern congressmen urged that all Negroes be confined to stevedore regiments to labor under white commissioned and non-commissioned officers. Fearing that this would be done, Negro leaders protested, charging the War Department with conscripting Negroes for labor. The Secretary of War, of course, assured them that nothing of the sort was planned when it was actually being done.

**Restriction
in the service
required.**

To the Service of Supply regiments most Negro draftees were sent. Not less than three-fourths of the 200,000 of the Negroes sent to France were reduced to laborers. It resulted that one-tenth of the population of the nation was compelled by a country fighting for democracy abroad, to supply three-fourths of the labor of the expeditionary force. They were commanded, moreover, largely by illiterate, prejudiced white men, and finally all but enslaved in the Service of Supply divisions abroad by unsympathetic whites, the majority of whom were southerners on the order of slave drivers. These draftees were subjected to unnecessary rigor; they were assigned unusually hard tasks; they were given inadequate recreation, while white soldiers in the same camp were exempted from these hardships. Abusive language, kicks and cuffs and injurious blows were the order of the day in dealing with the Negroes impressed into this branch of service. As there were in these camps no Negroes in touch with the outside world except the Young Men's Christian Association secretaries, and the slave-driving officers suc-

**In the Service
of Supply.**

ceeded in displacing some of these, there was no one to whom these Negroes could take a complaint. The Bureau of Negro Economics directed by George E. Haynes in the Department of Labor was very busy with various plans during the war, but did not seem to improve the life of the Negro laborer in the army or in civil life; and the services of Emmett J. Scott as Special Assistant to the Secretary of War had little bearing on the situation.

These Negroes, however, accepted their lot as good soldiers. Loyal to the cause of humanity, they without murmur faced humiliation, hardships, and insult. But the universal opinion is that the Negro stevedore, in spite of all he had to endure, was the best laborer in the war and that without this efficient service the Allies could not have been supplied with food and munitions rapidly enough to save them from exhaustion. These men were stationed at the English and French ports and at depots like that at Givres, where millions of American wealth handled by 25,000 men passed through enormous masses of warehouses with 140 miles of interior railroad lines for the handling of freight. They unloaded the transports, prepared the vehicles to convey the supplies to the interior, and built depots for storing them. When the way to the expeditionary force lay through woods and over hills, the labor battalions built roads from the port of entry to the front. They, moreover, buried the dead, salvaged war material, and detonated explosives scattered over France by the enemy.

The Negroes were diplomatically told that they would be drafted to fight in the ranks as other men. The War Department, however, was not at first sure that the army could make use of the Negro as an officer. Seeing what little hope this situation offered the thousands of well-educated Negroes who in the army would be serving under inferior whites, the students and a few members of the faculty

**Loyal in
spite of dis-
crimination.**

of Howard University instituted a nation-wide campaign for a training camp in which Negroes of certain educational qualifications should have the opportunity to qualify as officers in the national service. As this movement soon had the support of all Negro schools of consequence and was promoted, too, by many white and black citizens, the War Department was forced to take the matter under advisement. After

**The demand
for Negro
officers.**

some hesitation the administration decided to establish at Fort Des Moines a camp for the training of colored officers. There was, however, much apprehension as to how the experiment would work out and still more as to whether the United States Government would actually commission a large number of Negro officers. Six hundred and seventy-five of the twelve hundred accepted at the camp, however, were commissioned



COL. CHARLES YOUNG, the highest ranking Negro graduate of West Point

in October, 1917, and the country saw going hither and thither the largest number of Negroes who had ever worn the stripes and bars.

The Negro officer, however, had already been proscribed. The administration had granted the Negro this recognition to secure the support of the Negroes for the war, but the Negro officer was not desired in the army, and the personnel in control did not intend to keep him there. Colonel Young was soon

**Proscription
of the Negro
officer.**

retired because of high blood pressure from which he did

not dreadfully suffer until in a time of rapid promotion in the army it seemed likely that he would advance high enough to command too many white men and disturb race superiority in the United States. Then followed in the cantonments the campaign to discredit and force the Negro officer out of the army. Through the Secretary of War, Emmett J. Scott was able to counteract some of these efforts made within the limits of the United States.

This attack, however, finally centered on the Negro officer in action in France, as it was a little difficult to do here some things which could be effected abroad before the War Department could intervene. In the **Fighting the Negro officer in France.** 92nd Division, in which most of the Negroes trained at Fort Des Moines served, the Negro officer suffered unusually. The division was placed in command of an incompetent man, General Ballou, who, surrounded by officials prejudiced against the Negro, became unduly influenced thereby and shaped his policy accordingly. He showed very little judgment in trying to force his division to accept race discrimination, and still less in criticizing Negro officers in the presence of their subordinates, saying that they were failures before they had been tested. Wherever Negro officers were stationed, moreover, a systematic effort was made to get rid of them by bringing them as early as possible before efficiency boards to find excuses for their retirement or assignment to labor battalions. In regiments where there were all Negroes, as in the New York Fifteenth, from which Colonel Hayward, the white commander, secured the transfer of all Negro officers after retiring a few for inefficiency, the same end was reached. The staff could then contend that as additional officers thereafter were necessary and other Negro officers could not be supplied, the regiment would have to take on white officers altogether, since officers of the two races

The Negro In the World War



THE NEW YORK FIFTEENTH IN THE WORLD WAR

could not serve together. Many superior officers openly asked that white officers be sent to their regiments regardless of the question of efficiency.

To carry out this purpose grave complaints were filed against the Negro officers. They were often charged with cowardice, although the Negro soldier was by the same man **Methods used.** praised for his bravery. Such a charge was preferred against four officers of the 368th Regiment who, having received the wrong orders and finding themselves entangled in barb wire while under the fire of the enemy's guns, retreated. As a matter of fact, these troops had not been prepared for this attack. They were without maps, without hand grenades, and without adequate ammunition. Major Elser, a white officer supposed to be leading them, was nowhere to be found during the engagement. Two of the Negro Captains, according to Ralph W. Tyler, a war correspondent, after they had gone over the top and had run into a nest of machine guns, turned back and asked for support and got the third battalion. But they could not get into touch with their Major, who, immediately after the engagement became serious, had retired to the rear somewhere, making it impossible for the captain to connect with him to secure orders. This Major, however, because of the failure of the engagement under such circumstances, charged the Negro officers with cowardice and inefficiency. As a reward for his cowardice, however, he was a few days thereafter raised to the rank of Lieutenant-Colonel and given command of a Negro regiment. An investigation by the Secretary of War showed that these officers were not to be blamed and he exonerated them, taking occasion to laud these and other Negro soldiers for their valor and patriotism.

In keeping with the policy of eliminating Negro officers from the army, Colonel Allan J. Greer addressed a letter for this purpose to Senator K. D. McKellar, in violation of

a law which, in a country believing in justice, would subject him to court martial. Pointing out the so-called weakness in the Negro officer he said: "Now that a reorganization of the army is in prospect, and as all officers of the temporary forces have been asked if they desire to remain in the regular army, I think I ought to bring a matter to your attention that is of vital importance, not only from a military point of view but from that which all Southerners have. I refer to the question of Negro officers and Negro troops.

A step beyond Bounds.

"The record of the division," said he, "is one which will probably never be given full publicity, but the bare facts are about as follows: We came to France in June, we were given seven weeks in the training area instead of the four weeks in training area as usually allotted, then went to a quiet sector of the front. From there we went to Argonne, and in the offensive starting there on September 26, had one regiment in the line, attached to the 38th French Corps. They failed there in all their missions, laid down and sneaked to the rear, until they were withdrawn. Thirty of the officers of this regiment alone were reported either for cowardice or failure to prevent their men from retreating, and this against very little opposition. The French and our white field officers did all that could possibly have been done; but the troops were impossible. One of our Majors commanding a battalion said, 'The men are rank cowards; there is no other word for it.' "

While these white officers of superior rank were persistently trying to weed out the Negro officers on the grounds of their inefficiency, the French, who were fortunately brigaded with some of the troops commanded by them, had nothing but words of praise for their gallant leadership. Among the French officers of consequence who thus complimented them were Colonel Tupes and General Goybet. In fact, the French

Praised by the French.

officers, easily observing that the trouble with the Negro officer and his American superior was merely a question of color, often interfered to save many a Negro officer from humiliation and from dishonorable discharge from the army. That there was no truth in the reports as to the general inefficiency of the Negro officer is evidenced by the fact that the 370th (the 8th Illinois), which was officered throughout by Negroes, rendered such gallant service that it received more citations and *croix de guerre* than any other American regiment in France. And many wondered how it could be possible for a Negro to be such a good soldier and have no possibility for leadership.

It is true that some Negro officers were inefficient; and so were many whites, thousands of whom could not stand the ordeal. It is true also that it does not make for the morale of the army to criticize, abuse and humiliate an officer in the presence of his men. **The criticism unjust.** If the white officers could not by army regulations be forced to respect the Negro officers, how could the Negro soldiers be expected to do so? Yet it is not true that the Negro soldiers in France did not respect and follow their Negro officers. Unusually proud of the honor conferred upon men of their race, they rather treated them with every mark of respect. The Negro officers were not lowered in the estimation of the Negro soldiers by the whiff and scorn of the white officers higher in the ranks, for the same dart of prejudice hurled at the Negro officer was also directed against Negro soldiers. They were all in common to be socially proscribed in France by Americans while fighting to make the world safe for democracy.

A few cases in evidence will be interesting. Certain colored troops were ordered to sail on the battleship *Virginia*, but after going aboard, the officer in charge had **Insult.** these troops removed on the ground that no colored troops had ever traveled on board a United States

battleship. Where under ordinary circumstances it would have been sometimes necessary for officers of both races to eat together, special arrangements were made so as to have the whites report to certain quarters while the blacks went to another, the blacks having in most of these cases inferior accommodations. Planning for a reception of General Pershing at one of the forwarding camps, General Logan ordered that all troops except Negroes should be under arms. Negro troops not at work were to be in their quarters or in their tents.

Every effort was made to separate the Negro soldiers from the French people. General Ervin, desiring to reduce the Negro soldier to the status of undesirables, issued among other regulations in his order *Number 40* a proclamation that Negroes should not associate with French women. The order, of course, was not obeyed, but an effort was made to enforce it even in the case of Negro officers. Some Negro officers who were in school at Vannes accepted the invitation to attend certain entertainments given for charity as Franco-American dances requiring an admission fee. Upon hearing of this, General Horn prohibited their attendance by ordering that no officer of the 167th Brigade should be permitted to attend a dance where a fee was charged, although the white officers at this same school, but belonging to other brigades, could attend.

To extend systematically the operation of race prejudice throughout France the Americans had issued, August 7, 1918, through a French mission from General Pershing's headquarters certain *Secret Information concerning Black American Troops*. The Americans proclaimed that it was important for French officers in command of black Americans to have an idea as to the status of the race in the United States. The Negroes were branded as a menace of degeneracy which could be escaped

Prejudice in the army.

A bold slander.

only by an impassable gulf established between the two races, and especially so because of the tendency of the blacks to commit the loathsome crime of assault, as they said the Negroes had already been doing in France. The French were, therefore, cautioned not to treat the Negroes



MAJOR JOEL E. SPINGARN, an enemy
of prejudice in the army

with familiarity and indulgence, which are matters of grievous concern to Americans and an affront to their national policy. The Americans, it continued, were afraid that the blacks might thereby be inspired with undesirable aspirations. It was carefully explained that although the black man is a citizen of the United States he is regarded by the whites as an inferior with whom relations of business and service only are possible; that

the black is noted for his want of intelligence, lack of discretion, and lack of civic and professional conscience. The French Army then was advised to prevent intimacy between French officers and black officers, not to eat with them nor shake hands nor seek to talk or meet with them outside of the requirements of military service. They were asked also not to commend too highly the black American troops in the presence of white Americans. Although it was all right to recognize the good qualities and service of black Americans, it should be done in moderate terms strictly in keeping with the truth. The French were urged

also to restrain the native cantonment population from spoiling the Negroes, as white Americans become greatly incensed at any deep expression of intimacy between white women and black men.

From accessible evidence it is clear that if some of the American soldiers had struggled as hard to defeat the Germans as they did to implant race prejudice in France, the army would have been much nearer the Rhine when the armistice was signed. They failed, however, to bring the French around to their way of seeing liberty, and the Negroes, in appreciation for the democracy of France as they saw it and felt it, willingly sacrificed their lives to save the beautifully humane people. Whether in Champagne, in the Argonne Forest or at Metz, it was the history of the Negro repeating itself—unflinching stand before the brutal enemy, eagerness to engage in the conflict, and noble daring endurance in the heat of the battle. Many a white soldier, many a white officer, returned with the testimony that they were braver than any white man that ever lived. They fought the enemy from behind and in the front and still came out the victor. But they were not merely victors. A score of them, like Roberts and Johnson of the New York Fifteenth, returned as heroes decorated by France for their bravery in action and their glorious triumph over Germans by whom they were greatly outnumbered.

Thinking that the record of the Negro in France might be taken as a reason for enlarging his measure of democracy for which he fought, the Negro-hating element in the army, navy, and civilian life organized to prevent this even before the close of the war. They tried so to intimidate the Negroes on their return home that they might remain content to continue in a position of recognized inferiority. The temper of editorials appearing in reactionary newspapers indicated

The Negro as a fighter.

The welcome home.

a hostile reception for Negro soldiers returning from the war, and soon southerners openly declared that such demands would be firmly met with opposition typical of the Ku Klux Klan. The returning Negro soldier was, therefore, for the South, an object of contempt. The very uniform on a Negro was to the southerner like a red rag thrown in the face of a bull. Negro soldiers re-



FIRST SEPARATE BATTALION OF THE DISTRICT OF COLUMBIA, receiving the Croix de Guerre in France

turning to the South then were beaten, shot down, and lynched, to terrorize the blacks insisting on better treatment for their race. They were not guilty of the violation of any law, but the South considers it advisable to lynch a few Negroes even when it is known that they are innocent; for it generally results in terrorizing others who might otherwise insist that they be treated as men.

This post-war down-with-the-Negro propaganda spread from the South into some points in the North, and finally

reached Washington, the capital of the nation, itself. During the second decade of the century Washington was southernized by an influx of public functionaries and civil service employés hypocritically parading as promoters of democracy but inalterably attached to the caste of color. On the nineteenth of July, 1919, then, there appeared in the streets of Washington, a number of soldiers, sailors and marines, who because of exaggerated reports that Negroes had assaulted white women and the rumor that the wife of a marine had been thus attacked, proceeded to the southwest section of Washington where they beat several innocent Negroes. On Sunday, the following day, these whites on leave from the United States Army and Navy, supported by civilians, had effected a better organization to carry out their purposes. They formed at Pennsylvania Avenue and Seventh Street a mob which took over the city from the Capitol to the White House. Negroes were pulled from vehicles and street cars and beaten into unconsciousness. One was thus taken possession of by the mob and beaten unmercifully right in front of the White House, where the President must have heard his groans but has not as yet uttered a word of protest. Other Negroes were shot and left to die on the streets.

Race war in Washington.

Going along Pennsylvania Avenue, that night, the author himself walked into the midst of the mob at the intersection of Eighth Street and Pennsylvania Avenue. Before he realized where he was, there resounded shots all around him. A large mob swept down Pennsylvania Avenue pursuing a Negro yelling for mercy, while another mob at the debouchment of Eighth Street had caught a Negro whom they conveniently adjusted for execution and shot while the author, walking briskly as possible to escape the same fate himself, heard the harassing groans of the Negro. To be sure that their murderous

A lynching in Washington.

task was well done a leader yelled to the executioners, "Did you get him?" The reply was, "Yes, we got him."

The events of the following day, however, showed that this mob had misjudged the Washington Negroes. They made extensive preparation for the retaliatory onslaught of the whites. Weapons were bought, houses were barricaded, and high powered automobiles were armored for touring the city late in the night. The augmented police force and the 300 provost guards supplied with rifles and machine guns did not deter the Negroes. When attacked by the white mob they easily stood their ground, and took the offensive when the white mob attempted to invade Negro quarters, although Thomas Armistead, charging in defense of the Negroes, fell mortally wounded. Whereas the whites wounded about 300 Negroes the Sunday night when they were not expecting the attack, the casualty list of Monday night showed two Negroes and four whites killed and a much larger number of whites wounded than Negroes.

A riot almost of the same order broke out in Chicago a few weeks later. In that city the large migration of Negroes to its industrial plants and the invasion of desirable residential districts by these newcomers incensed the whites to the point of precipitating a race war. The Negroes, however, showed by the number of whites killed the same tendency of the Washington Negro to retaliate when attacked by cowards. The Negro helped to save democracy abroad, but he must fight to enjoy it at home.

CHAPTER XX

THE NEGRO AND SOCIAL JUSTICE

DURING the last quarter of a century the Negro has had some ground for hope in the forces which bid fair to bring about a social readjustment involving the leveling of society if not the elevation of the underman to rule over his hitherto so-called superiors.¹

**Impending
crisis.**

All elements of our population during this period have been subject to change by these evolutionary movements at work among the masses. The laboring man is no longer a servile employee of serf-like tendencies, but a radical member of a dissatisfied group, demanding a proper division of the returns from his labor. He is made more potential in this position by a recent propaganda to the effect that, so far as the laboring man is concerned, political affiliation means little, since all parties have been under the influence of aristocratic leaders, who, taking advantage of the ignorance of their constituents, have been able to rule this country for the benefit of those that *have* rather than in the interest of those that *have not*. In conformity then with the cycles of government borne out by history, this country has passed through the stage of aristocracy to that of the white man's democracy and bids fair to be revolutionized

¹ This study may be further extended by reading W. E. B. DuBois's *The Soul of Black Folk*, his *The Negro*, William Picken's *The New Negro*, Kelly Miller's *Race Adjustment*, *Out of the House of Bondage*, and *Appeal to Reason*. *The Atlanta University Studies* and the *Occasional Papers of the American Negro Academy* are helpful. The files of *The Crisis*, *The Messenger*, *The Crusader*, *The Boston Guardian*, *The Chicago Defender* and *The New York Age* should be consulted.

in the near future by the rule of the mob represented by so-called organized labor. In other words, the country has developed from aristocracy to frontier democracy, from frontier democracy to progressivism and from progressivism almost to socialism.

This has been all but true even in the South where this social upheaval has expressed itself politically in the rise of the poor white man. During the days of slavery the South and, to some extent, the whole country, continued under the domination of aristocratic slaveholders. The poor whites, driven to the uplands and the mountains where slavery was unprofitable, never accumulated sufficient wealth to attain political recognition enjoyed by those living near the coast, despite the fact that there were numerous clashes, urgent debates, charges, and counter-charges coming from discordant elements among the mountain whites requiring an equalization of political power. When, however, after 1850 and especially after the Civil War there resulted an extension of the franchise, making it universal free manhood suffrage, the poor whites did not long delay in realizing the power given them through the ballot. Under the leadership then of men like James K. Vardaman, Benjamin Tillman, and Cole Blease, these uplanders have come into their own. Lacking that sympathy for the Negroes found among the ex-slaveholders, these poor whites have in getting control of the southern governments, however, effected sufficient changes to deprive the blacks of their civil and political rights and even of some economic opportunities. Giving so much attention to the perpetuation of caste, then, the molders of public opinion in the South have not permitted the radically democratic movements to invade that section. There it was discovered that it would be impossible to live up to the principles set forth without giving the Negroes a larger share of social and

**The rise of
the poor
whites.**

**Radical
leaders.**

political privileges. In the North, where a smaller number of Negroes have been found, there has not been any serious handicap to such movements. So far as the **The situation in the North.** Single Taxers, the Socialists, and the *Bolsheviks* are concerned, the Negro may share at their table the same blessings vouchsafed to others. The rank and file of

the people, however, have hesitated to recognize the Negro. Leaders in the North are still trying to decide how large a share of social justice, how much of the world-wide democracy, the Negro should enjoy.

The Negro, however, has been loath to Conservatism drift into anarchy. His claim for social justice is rightly based on his work as a conservative and constructive force in the country. Although the present day encroachment on the part of the degraded class of whites has forced many Negroes to take up

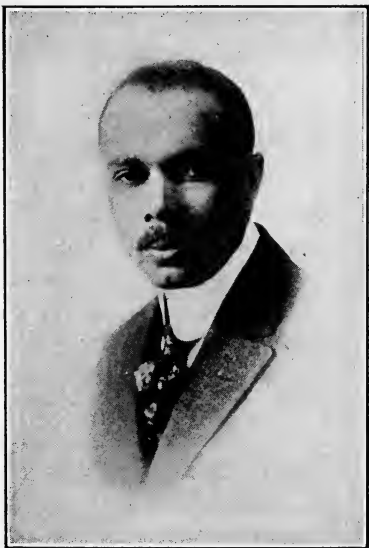

JAMES WELDON JOHNSON, Secretary of the National Association for the Advancement of Colored People

arms in self-defense, as in Houston, Washington, and Chicago, in Elaine, Arkansas, Knoxville, Tennessee, and Tulsa, Oklahoma, the blacks have not and do not desire to become radical. Increasing persecution, however, is gradually forcing Negroes on the defensive into the ranks of the Socialists and Radicals. Negro preachers, editors, and teachers, who have for years pleaded at the bar of public opinion for the recognition of the Negro as a man, now find

colored
people
members

themselves unconsciously allied with the most radical forces in the United States. This, of course, if not arrested by a more sympathetic consideration of the Negro's rights, may increase the ranks of the malcontents to the extent of effecting a general upheaval in this country.

It is well to note that there no longer exists a frontier with all of its opportunities for free arable land, where in the midst of so many changes, frontiersmen passed so rapidly through the various stages of the civilization of the backwoods, the farm, the town and the city that in a generation they became thoroughly Americanized. Since 1890 we have been confronted with the aftermath of the frontier—the increase of restlessness, pessimism and revolutionary sentiment, aggravated by the presence of un-Americanized foreigners who, no longer able to go West, must remain in our large cities to wage war against the capitalists whom they now consider the source of all their evils.

Labor and capital now face each other in the cities in a restricted area, and each has to combine to protect its **The conflict in cities.** interests. The combination of capital was impossible when land was abundant and individualism was strong. To protect the weak we are now reduced to a new sort of radicalism which differs from that of the European Socialists in that while the latter are trying to build a democracy out of the remains of monarchical life, our malcontents are resorting to various political experiments to hold on to the ideals of the frontier which have been shattered by the concentration of the population in cities. There has followed, therefore, such assimilation of the black and white people to urban conditions as to mark an epoch in the making of our civilization, effecting a revolution not only in industry but in politics, society, and life itself. The rural society has been destroyed by commercialism, which has transformed the majority of the

American people into commercial beings. As more than half of the people of the United States now live in urban communities of over 5000 inhabitants, the problems of this country tomorrow will be the problems of the city. As the cities are now in control of the most radical elements in the United States, it is only a matter of time before the national policy will be dominated by radical thought, and men disposed to hold on to the best in republican government should think seriously of the danger of driving by persecution into the ranks of this unrestrained element the Negroes, who constitute the most conservative and the most constructive stock in America.

With the migration of a large number of Negroes to northern cities, however, there have been tendencies indicating that wherever Negroes are numerous enough to impress themselves upon the community,

disturbing race prejudice develops. We hear, therefore, of the agitation for separate schools in **Race conflict.** Philadelphia, Pittsburg, Columbus, Indianapolis, and Chicago. There is also a desire among certain whites, not necessarily to segregate the Negroes by special ordinances to that effect, but by a common understanding to restrict them to certain parts of the cities where they



MARY WHITE OVINGTON, Chairman of the Board of Directors of the National Association for the Advancement of Colored People

may not come into such close contact with the so-called superior whites. Race prejudice in these parts then has become much more volcanic at times than it is in certain sections of the South, as was evidenced by the recent riots at Chester, Pennsylvania, Youngstown, Ohio, East St. Louis, and Chicago. Although it does not appear that any part of the North has, as in the case of the regions like that around Tyler, Texas, developed into what may be properly styled a criminal community, it has shown possibilities in that direction.

The greatest difficulty of all which the Negroes have had in the North has been the problem of earning a living. When the North had few Negroes on its hands it was an **The economic problem.** unusually pleasant experience for a Negro to go to that section and spend his money without restriction, enjoying all of the social privileges usually denied the Negroes in the South. But until recently it had always been extremely difficult for the same persons of color permitted to worship in a white church or to attend a white school to earn a living among these same sympathetic persons. It is only since 1916, when the Negroes went North in such large numbers as to enable employers to hire enough of them to take over the entire operation of plants, that they have easily succeeded in finding employment.

This difficulty has seemed a problem impossible of solution for the reason that back of the protests against the employment of Negroes in higher pursuits have been the **Trades unions.** unions, wielding such power that in the economic world their will has been law. Several years ago the American Federation of Labor declared that its purpose was for the organization of all working people without regard to class, race, religion, or politics; that many organizations affiliated with the American Federation of Labor had within their membership Negro workmen with

all other workers of trades; and that the American Federation of Labor had made and was making every effort within its power for the organization of these workmen. This, however, was largely diplomacy; but a change of attitude was evident as early as 1910 when the national council of the American Federation of Labor unanimously passed a resolution inviting persons of all races to join, giving also instructions for making a special effort to organize Negroes, in 1913. It required the dearth of labor during the World War, however, to give the Negroes such a basis for economic freedom in the North as to secure actual consideration from the trades unions. Seeing that Negroes had to be employed and that they would be worth so much more to the trades unions than the latter would be to the Negroes, the American

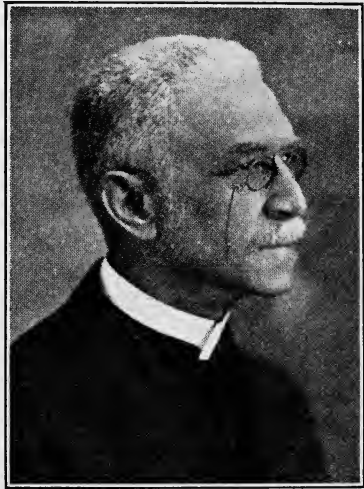

DR. F. J. GRIMKÉ, a preacher of the New Democracy

Federation of Labor feebly expressed a desire for the organization of Negro laborers as units of the various trades unions.

In carrying out this program, however, the American Federation of Labor was taking high ground. In fact, it found itself far in advance of the sentiment favorable to the Negro in the rank and file of the local trades unions themselves. There was a tendency nominally to admit the Negroes to the union when it was found that their competition was such as to necessitate

**The position
of the unions.**

their admission, and thereafter, by certain excuses and peculiar methods of evasion, to employ white men in preference to the Negroes, although the latter might be members of the union. During the migration, however, the American Federation of Labor had to take another stand. At the annual meeting of the American Federation in 1916, therefore, it was reported that the Negroes who were then being brought North were to fill the places of union men demanding better conditions and it was, therefore, felt necessary to take steps to organize these Negroes who were coming in rather large numbers to be checked by strikes and riots.

The following year, the American Federation of Labor, after giving more attention than ever to the situation of labor conditions among the blacks, found it-
Attention self somewhat handicapped because of the
given fact that not only was there an antipathy of
Negroes. the Negro toward the labor unions, but they were not informed as to their operations and their benefits. It was, therefore, urged that a Negro organizer be appointed to extend the work of these trades unions among them. Many of the delegates assembled thought it advisable to suggest that at the peace table closing up the World War the American people should endeavor to influence the nations participating in this conference to agree upon a plan of turning over the continent of Africa or certain parts thereof to the African race and those descendants of the same residing in this country.

At the meeting of the American Federation of Labor in Atlantic City in 1919, there was reached the decision to admit Negroes indiscriminately into the various trades unions, enjoying the same privileges as the whites.
The American Proclaiming thus so boldly the abolition of
Federation of race distinction in the labor organizations, the
Labor in 1919. American Federation of Labor has at least laid the foun-

dation for the economic advancement of the blacks. This declaration, however, must be accepted merely as a basis upon which the Negro may take his stand for the economic struggle before him. Broad as the decision may seem, it must, like any other law or constitution, be carried out by persons who, if not sympathetically disposed, may give this decision such an interpretation as to make it mean nothing. Liberal as the American Federation of Labor may now be, moreover, the Negroes to come into their own, enjoying economic liberty, must still bring about such changes in the laws and constitutions of the labor locals as to permit the carrying out of the purpose of the national body. As the matter now stands, then, the victory has been won in the national council, but the battle is yet to be waged in the locals.

A number of Negroes, not content with the efforts for their economic advancement made from without, have endeavored to remedy their own evils through agencies either established by Negroes or by white persons closely coöperating with them. One of the factors in effecting the proper distribution of labor during the World War and in securing for them justice

**Efforts
among
Negroes.**

in many communities where they would have otherwise been imposed upon, was the National League on Urban Conditions among Negroes. This is an organization with eighteen branches dealing with the Negro laboring, dependent, and delinquent classes in the various large cities. The Negroes have organized also in New York a Negro labor union largely intended to find employment for Negroes rather than to secure an increase in their wages. In the Southwest, there has been organized the Inter-State Association of Negro Trainmen of America, intended to perfect the union of all unorganized railway employees of color. During the World War there have been several such organizations following in the wake of this, and recently an

effort has been made to effect the organization of a national body which will be for the Negroes just what the American Federation of Labor has been for the whites.

The Negroes have sought justice, too, not by trying to force themselves socially on the whites, but by certain im-

**A just
complaint.**

provements in the situations in which they now are. One of their attacks is directed

against the poor railroad accommodations in the separate cars and stations assigned Negroes in the South. They

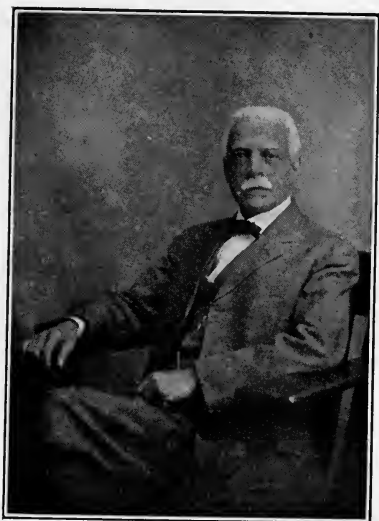

A. H. GRIMKÉ, "A Defender of His People"

complain also of the inadequate school facilities, contending that it is poor logic to insist that the Negroes must be denied certain privileges because of their undeveloped state and at the same time be refused those opportunities for improvement necessary to make themselves worthy of those privileges which they are denied. They have insisted that certain recreational facilities be given the Negroes in the interest of their contentment and health, which are essential to the

maintenance of that physical strength necessary to efficient labor. They have wisely contended also that if the white man is the superior of the two, the Negro must be brought into sufficiently close contact with the whites so as to learn by example. Segregation will tend to keep one part of a community backward while the other is hopelessly struggling to go forward.

In spite of this, however, the South has spoken out more boldly than ever for a more radical segregation of the race, with a view to preventing miscegenation. Southern leaders believe that if you permit Negroes to be elevated to positions of importance, it will be **Radical reaction.** only a matter of a few generations before they will be sufficiently attractive to white persons to promote the intermarriage of the races. Inalterably attached to their own ideal and believing in their superiority as the chosen people of God in line of succession with the Jews, the whites have insisted upon all sorts of social and political proscription, in fact, every measure necessary to discourage the recrudescence of the miscegenation of the races. There has been, therefore, among those southerners who have endeavored to fall in line with the radical democratic and social movement, a tendency to accept the program so far as it does not include the Negroes. As a natural consequence, then, they have brought around to their way of thinking a large number of southern men who have gradually gained control of the northern press, idealizing the institutions of the South, pitying that section because of being handicapped by the presence of the Negro and demanding for the freedman exemption from unusual cruelties and persecution only, while ignoring the clamor for recognition as a real citizen of the United States.

To justify this position there have come forward a number of writers disguised as scientific investigators to prove by psychology and ethnology that the Negro is a sort of inferior being. They disregard the conten- **Biased** tion of the world's best scientists that no race **investigators.** is essentially inferior to any other race and that differences in civilization have resulted from varying opportunities and environments. Loath to give up this theory of superiority, however, they have devised various schemes to make a case for the natural superiority of the white man.

Among these methods have been the collection of data intended to show that the Negro is naturally a criminal. Some have made psychological measurements of various types of humanity with a view to proving that the Negro is mentally weaker than other peoples. Others are busy writing history of the countries outside of Africa to prove that the Negroes in Africa are inferior to races without.

A passing remark as to these methods may be worth while. In almost all of the investigations as to the crime of the Negroes the evidence is *ex parte*. No man should **Unscientific** be condemned as a criminal merely on the **conclusions.** testimony of his enemies. In the matter of criminal statistics of the Negro the evidence is always questionable, for the white man is the sole judge. He makes the arrest, determines the guilt of the Negro, and applies the penalty. Just as during the days of slavery prejudiced masters spoke of the crimes of their slaves and branded free Negroes as pariahs of society, so now we hear the same concerning the Negroes. In other words, all of this evidence is from those persons who, making desire the father of thought, have issued statements without evidence to support them. Such so-called statistics of the whites adversely critical of the Negroes, against whom they are intensely prejudiced and to whom they have denied the rights and privileges of men, are worthless in seeking the truth.

In making some of the psychological measurements the experiments have been very interesting. One man found in a white school a Negro who showed more mental capac- **Measurements** ity than any other member of the institu- **used.** tion. To explain this away in keeping with his theory that the Negro is inferior, he contended that the Negro far off in the North among the white people by himself was better selected than the whites. In another case, in which the purpose of the experiment was to prove that the

Negro was inferior both to the Indian and white man, it was discovered that the Negro stood between the Indian and the white man. Adhering to the contention that the Negro was still inferior even to the Indian, the biased writer attributed the Negro's superior mental capacity to his closer contact with the white man.

Until the students of the white race give the same attention to the study of Africa which they have given to the study of the history of Europe and Asia, they will be unprepared to reach any conclusions as to the sort of civilization which the Negro race has produced and its relative value. The fact

**The
necessity for
investigation.**

is that the white man is still ignorant as to what has taken place in Africa. His knowledge is confined largely to the countries on the border and the reports of sporadic explorations into the interior. Because the whites of modern times succeeded in finding in Africa slaves for exploitation at the time when the country was torn to pieces by wars of migrating hordes, they have concluded that these weak captives in war, whom they enslaved and debased, must be taken as a sample of what the Negro is capable of. Yet if the Negroes of this country are to serve as an indication of the capabilities of the race, it is both unscientific and unjust to expect the Negroes to pass through two hundred and fifty years of slavery and in three generations achieve as much as the whites have during many centuries. If they could, instead of thereby showing that they are equal to the whites, they would demonstrate their superiority.

To disabuse the public mind of this slander proceeding from ill-designing investigators, C. G. Woodson organized the Association for the Study of Negro Life and History in Chicago in 1915, hoping to save and publish the records of the Negro, that the race may not become a negligible factor in the thought of the

**The study of
the Negro.**

world. The work of this Association is to collect sociological and historical data, to publish books on Negro life and history, to promote studies in this field through schools and clubs with a view to bringing about harmony between the races by interpreting the one to the other. The supporters of the movement have been well known philanthropists like Moorefield Storey, Julius Rosenwald and John D. Rockefeller, Jr., writers like Roland G. Usher, John M. Mecklin, Justice W. R. Riddell, Jerome Dowd, J. Franklin Jameson, and Charles H. Wesley, and publicists like Frederick L. Hoffman, Talcott Williams, and Oswald Garrison Villard. For several years the Association has published works bearing on all phases of the Negro and also *The Journal of Negro History*, a quarterly scientific magazine which now circulates throughout the civilized world as a valuable help to students and investigators.

A new note in the progress of the Negro has been sounded in the appeals of the churches and the civic organizations in behalf of a square deal for the Negro, as the murder of Negroes has led to the murder of white men and the whites,² therefore, call for a halt all along the line. Citizens of both races have been appointed by mayors, governors and the like to effect an agreement by which both races may live together for the greatest good of the greatest number. An effort also has been made to bridle the radical press which, during the last two generations, by playing up in bright headlines the crimes of Negroes and suppressing the similar crimes of whites, has inflamed the public mind against the Negroes as a naturally criminal class. A new day is dawning.

² See Lincoln's speech on lynching in the Appendix.

APPENDIX

Speaking of the effect of the Missouri Compromise, John Quincy Adams, then Secretary of State, said :

I said that this confounding of the ideas of servitude and labor was one of the bad effects of slavery; but he (Calhoun) thought it attended with many excellent consequences. It did not apply to all kinds of labor—not, for example, to farming. He, himself, had often held the plow; so had his father. Manufacturing and mechanical labor were not degrading. It was only manual labor—the proper work of slaves. No white person could descend to do that. And it was the best guarantee to equality among the whites. It produced an unvarying level among them. It not only did not excite, but did not even admit of inequalities, by which one white man could domineer over another.

I told Calhoun I could not see things in the same light. It is, in truth, all perverted sentiment—mistaking labor for slavery, and dominion for freedom. The discussion of this Missouri question has betrayed the secret of their souls. In the abstract they admit that slavery is an evil, they disclaim all participation in the introduction of it, and cast it all upon the shoulders of our old Grandam Britain. But when probed to the quick upon it, they show at the bottom of their souls pride and vainglory in their condition of masterdom. They fancy themselves more generous and noble-hearted than the plain freemen who labor for subsistence. They look down upon the simplicity of a Yankee's manners, because he has not habits of overbearing like theirs and cannot treat negroes like dogs. It is among the evils of slavery that it taints the very sources of moral principles. It establishes false estimates of virtue and vice; for what can be more false and heartless than this doctrine which makes the first and holiest rights of humanity to depend upon the color of the skin? It perverts human reason, and reduces men endowed with logical powers to maintain that slavery is sanctioned by the Christian religion, that slaves are happy and contented in their condition, that between master and slave there are ties of mutual attachment and affection, that the virtues of the master are refined and exalted by the degradation of the slave; while at the same time they vent execrations upon the slave-trade, curse Britain for having given them slaves, burn at the stake negroes convicted of crimes for the terror of the example, and writhe in agonies of fear at the very mention of human rights as applicable to men of color. The impression produced upon my mind by the progress of this discussion is, that the bargain between freedom and slavery contained in the Consti-

tution of the United States is morally and politically vicious, inconsistent with the principles upon which alone our Revolution can be justified; cruel and oppressive, by riveting the chains of slavery, by pledging the faith of freedom to maintain and perpetuate the tyranny of the master; and grossly unequal and impolitic by admitting that slaves are at once enemies to be kept in subjection, property to be secured or restored to their owners, and persons not to be represented themselves, but for whom their masters are privileged with nearly a double share of representation. The consequence has been that this slave representation has governed the Union. Benjamin portioned above his brethren has ravened as a wolf. In the morning he has devoured the prey, and at night he has divided the spoil. It would be no difficult matter to prove, by reviewing the history of the Union under this Constitution, that almost everything which has contributed to the honor and welfare of the nation has been accomplished in despite of them or forced upon them, and that everything unpropitious and dishonorable, including the blunders and follies of their adversaries, may be traced to them. I have favored this Missouri Compromise, believing it to be all that could be effected under the present Constitution and from extreme unwillingness to put the Union at hazard. But perhaps it would have been a wiser as well as a bolder course to have persisted in the restriction upon Missouri, till it should have terminated in a convention of the States to amend and revise the Constitution. This would have produced a new Union of thirteen or fourteen States unpolluted with slavery, with a great and glorious object to effect, namely, that of rallying to their standard the other States by the universal emancipation of their slaves. If the Union must be dissolved, slavery is precisely the question upon which it ought to break. For the present, however, this contest is laid asleep.—Stedman and Hutchinson, *American Literature* (N. Y., 1888), IV, 213-233, *passim*.

On these restrictions in Missouri John Sergeant, Pennsylvania member of Congress and appointed commissioner to the Panama Congress, said:

It is time to come to a conclusion; I fear I have already trespassed too long. In the effort I have made to submit to the committee my views of this question, it has been impossible to escape entirely the influence of the sensation that pervades this House. Yet I have no such apprehensions as have been expressed. The question is indeed an important one; but its importance is derived altogether from its connection with the extension, indefinitely, of negro slavery, over a land which I trust Providence has destined for the labor and the support of freemen. I have no fear that this question, much as it has agitated the country, is to produce any fatal division, or even to generate a new organization of parties. It is not a question upon which we ought to indulge unreasonable apprehensions, or yield to the counsels of fear. It concerns ages to come and millions to be born. It is, as it were, a question of a new political creation, and it is for us, under Heaven, to say what shall be its condition. If we

impose the restriction, it will, I hope, be finally imposed. But, if hereafter it should be found right to remove it, and the State consent, we can remove it. Admit the State, without the restriction, the power is gone forever, and with it are forever gone all the efforts that have been made by the non-slaveholding States, to repress and limit the sphere of slavery, and enlarge and extend the blessings of freedom. With it, perhaps, is gone forever the power of preventing the traffic in slaves, that inhuman and detestable traffic, so long a disgrace to Christendom. In future, and no very distant times, convenience, and profit, and necessity, may be found as available pleas as they formerly were, and for the luxury of slaves, we shall again involve ourselves in the sin of the trade. We must not presume too much upon the strength of our resolutions. Let every man, who has been accustomed to the indulgence, ask himself if it is not a luxury—a tempting luxury, which solicits him strongly and at every moment. The prompt obedience, the ready attention, the submissive and humble, but eager effort to anticipate command—how flattering to our pride, how soothing to our indolence! To the members from the south I appeal, to know whether they will suffer any temporary inconvenience, or any speculative advantage to expose us to the danger. To those of the north, no appeal can be necessary. To both, I can most sincerely say, that as I know my own views on this subject to be free from any unworthy motive, so will I believe that they likewise have no object but the common good of our common country; and that nothing would have given me more heartfelt satisfaction than that the present proposition should have originated in the same quarter to which we are said to be indebted for the ordinance of 1787. Then, indeed, would Virginia have appeared in even more than her wonted splendor, and spreading out the scroll of her services, would have beheld none of them with greater pleasure, than that cries which began, by pleading the cause of humanity in remonstrances against the slave trade, while she was yet a colony, and embracing her own act of abolition, and the ordinance of 1787, terminated in the restriction of Missouri. Consider, what a foundation our predecessors have laid! And behold, with the blessing of Providence, how the work has prospered! What is there, in ancient or in modern times, that can be compared with the growth and prosperity of the States formed out of the Northwest Territory? When Europeans reproach us with our negro slavery, when they contrast our republican boast and pretensions with the existence of this condition among us, we have our answer ready—it is to you we owe this evil—you planted it here, and it has taken such root in the soil we have not the power to eradicate it. Then, turning to the west, and directing their attention to Ohio, Indiana, and Illinois, we can proudly tell them, these are the offspring of our policy and our laws, these are the free productions of the constitution of the United States. But, if, beyond this smiling region, they should descry another dark spot upon the face of the new creation—another scene of negro slavery, established by ourselves, and spreading continually towards the further ocean, what shall we say then? No, sir, let us follow up the work our ancestors have begun. Let us give to the world a new pledge of our sincerity. Let the standard of freedom

be planted in Missouri, by the hands of the constitution, and let its banner wave over the heads of none but freedom—men retaining the image impressed upon them by their Creator, and dependent upon none but God and the laws. Then, as our republican States extend, republican principles will go hand in hand with republican practice—the love of liberty with the sense of justice. Then, sir, the dawn, beaming from the constitution, which now illuminates Ohio, Indiana, and Illinois, will spread with increasing brightness to the further west; until in its brilliant luster, the dark spot, which now rests upon our country, shall be forever hid from sight. Industry, arts, commerce, knowledge, will flourish with plenty and contentment for ages to come, and the loud chorus of universal freedom, re-echo from the Pacific to the Atlantic, the great truths of the declaration of independence. Then, too, our brethren of the south, if they sincerely wish it, may scatter their emancipated slaves through this boundless region, and our country, at length, be happily freed forever from the foul stain and curse of slavery. And if (may it be far, very far distant!) intestine commotion—civil dissension—division, should happen—we shall not leave our posterity exposed to the combined horrors of a Civil and a servile war. If any man still hesitate, influenced by some temporary motive of convenience, or ease, or profit, I charge him to think what our fathers have suffered for us, and then to ask his heart, if he can be faithless to the obligation he owes to posterity!—Moore, *American Eloquence* (N. Y., 1864), II, 531-532.

Calhoun, the champion of the slaveholding interests and a fearless defender of the justice of slavery, thus commented on abolition in 1837:

As widely as this incendiary spirit has spread, it has not yet infected this body, or the great mass of the intelligent and business portion of the North; but unless it be speedily stopped, it will spread and work upwards till it brings the two great sections of the Union into deadly conflict. This is not a new impression with me. Several years since, in a discussion with one of the Senators from Massachusetts (Mr. Webster), before this fell spirit had showed itself, I then predicted that the doctrine of the proclamation and the Force Bill,—that this Government had a right, in the last resort, to determine the extent of its own powers, and enforce its decision at the point of the bayonet, which was so warmly maintained by that Senator, would at no distant day arouse the dormant spirit of abolitionism. I told him that the doctrine was tantamount to the assumption of unlimited power on the part of the Government, and that such would be the impression on the public mind in a large portion of the Union. The consequences would be inevitable. A large portion of the Northern States believed slavery to be a sin, and would consider it as an obligation of conscience to abolish it if they should feel themselves in any degree responsible for its continuance,—and that this doctrine would necessarily lead to the belief of such responsibility. . . .

They who imagine that the spirit now abroad in the North will die away of itself without a shock or convulsion, have formed a

very inadequate conception of its real character; it will continue to rise and spread, unless prompt and efficient measures to stay its progress be adopted. Already it has taken possession of the pulpit, of the schools, and, to a considerable extent, of the press; those great instruments by which the mind of the rising generation will be formed.

However sound the great body of the nonslaveholding States are at present, in the course of a few years they will be succeeded by those who will have been taught to hate the people and institutions of nearly one-half of this Union, with a hatred more deadly than one hostile nation ever entertained toward another. It is easy to see the end. By the necessary course of events, if left to themselves, we must become, finally, two people. It is impossible under the deadly hatred which must spring up between the two great sections, if the present causes are permitted to operate unchecked, that we should continue under the same political system. The conflicting elements would burst the Union asunder, powerful as are the links which hold it together. Abolition and the Union cannot co-exist. As the friend of the Union, I openly proclaim it,—and the sooner it is known the better. The former may now be controlled, but in a short time it will be beyond the power of man to arrest the course of events. We of the South will not, cannot, surrender our institutions. To maintain the existing relations between the two races, inhabiting that section of the Union, is indispensable to the peace and happiness of both. It cannot be subverted without drenching the country in blood, and extirpating one or the other of the races. Be it good or bad, it has grown up with our society and institutions, and is so interwoven with them, that to destroy it would be to destroy us as a people. But let me not be understood as admitting, even by implication, that the existing relations between the two races in the slaveholding States is an evil:—far otherwise; I hold it to be a good, as it has thus far proved itself to be to both, and will continue to prove so if not disturbed by the fell spirit of abolition. . . .

I feel myself called upon to speak freely upon the subject where the honor and interests of those I represent are involved. I hold then, that there never has yet existed a wealthy and civilized society in which one portion of the community did not, in point of fact, live on the labor of the other. Broad and general as is this assertion, it is fully borne out by history. . . . I fearlessly assert that the existing relations between the two races in the South, against which these blind fanatics are waging war, forms the most solid and durable foundation on which to rear free and stable political institutions. It is useless to disguise the fact. There is and always has been in an advanced stage of wealth and civilization, a conflict between labor and capital. The condition of society in the South exempts us from the disorders and dangers resulting from this conflict; and which explains why it is that the political condition of the slaveholding States has been so much more stable and quiet than that of the North. The advantages of the former, in this respect, will become more and more manifest if left undisturbed by interference from without, as the country advances in wealth and numbers. We have, in fact, but just entered that condition of society where the

strength and durability of our political institutions are to be tested; and I venture nothing in predicting that the experience of the next generation will fully test how vastly more favorable our condition of society is to that of other sections for free and stable institutions, provided we are not disturbed by the interference of others, or shall have sufficient intelligence and spirit to resist promptly and successfully such interference. It rests with ourselves to meet and repel them. I look not for aid to this Government or to the other States; not but there are kind feelings toward us on the part of the great body of the non-slaveholding States; but as kind as their feelings may be, we may rest assured that no political party in those States will risk their ascendance for our safety. If we do not defend ourselves none will defend us; if we yield we will be more and more pressed as we recede; and if we submit we will be trampled under foot. Be assured that emancipation itself would not satisfy these fanatics;—that gained, the next step would be to raise the negroes to a social and political equality with the whites; and that being effected, we would soon find the present condition of the two races reversed. . . . Calhoun, *Speeches* (N. Y., 1856), II, 628-633 *passim*.

The beginnings of the *Liberator* are well set forth in this extract:

To the Public.

In the month of August I issued proposals for publishing the *Liberator* in Washington city; but the enterprise, though hailed in different sections of the country, was palsied by public indifference. Since that time, the removal of the *Genius of Universal Emancipation* to the Seat of Government has rendered less imperious the establishment of a similar periodical in that quarter.

During my recent tour for the purpose of exciting the minds of the people by a series of discourses on the subject of slavery, every place that I visited gave fresh evidence of the fact, that a greater revolution in public sentiment was to be effected in the free States—and particularly in *New England*—than in the South. I found contempt more bitter, opposition more active, detraction more relentless, prejudice more stubborn, and apathy more frozen, than among slave-owners themselves. Of course, there were individual exceptions to the contrary. This state of things afflicted, but did not dishearten me. I determined, at every hazard, to lift up the standard of emancipation in the eyes of the nation, *within sight of Bunker Hill and in the birthplace of liberty*. That standard is now unfurled; and long may it float, unhurt by the spoliations of time or the missiles of a desperate foe—yea, till every secret abettor tremble—let their northern apologist tremble—let all the enemies of the persecuted blacks tremble. . . .

I shall not array myself as the political partisan of any man. In defending the great cause of human rights, I wish to derive the assistance of all religions and of all parties.

Assenting to the "self-evident truth" maintained in the American Declaration of Independence, "that all men are created equal, and endowed by their Creator with certain inalienable rights—among which are life, liberty, and the pursuit of happiness," I shall strenuously contend for the immediate enfranchisement of our slave population. In Park Street Church, on the Fourth of July, 1829, in an address on slavery, I unreflectingly assented to the popular but pernicious doctrine of *gradual* abolition. I seize this opportunity to make a full and unequivocal recantation, and thus publicly to ask pardon of my God, of my country, and of my brethren, the poor slaves, for having uttered a sentiment so full of timidity, injustice, and absurdity. A similar recantation, from my pen, was published in the *Genius of Universal Emancipation*, at Baltimore, in September, 1829. My conscience is now satisfied.

I am aware that many object to the severity of my language; but is there not cause for severity? I *will be* as harsh as truth, and as uncompromising as justice. On this subject, I do not wish to think, or speak, or write, with moderation. No! no! Tell a man whose house is on fire to give a moderate alarm; tell him to moderately rescue his wife from the hands of the ravisher; tell the mother to gradually extricate her babe from the fire into which it has fallen,—but urge me not to use moderation in a cause like the present. I am in earnest—I will not equivocate—I will not excuse—I will not retreat a single inch—and I will be heard. The apathy of the people is enough to make every statue leap from its pedestal, and to hasten the resurrection of the dead.

It is pretended that I am retarding the cause of emancipation by the coarseness of my invective and the precipitancy of my measures. The *charge is not true*. On this question my influence,—humble as it is,—is felt at this moment to a considerable extent, and shall be felt in coming years—not perniciously, but beneficially—not as a curse, but as a blessing; and posterity will bear testimony that I was right. I desire to thank God, that he enables me to disregard "the fear of man which bringeth a snare," and to speak his truth in its simplicity and power. And here I close with this fresh dedication:

Oppression! I have seen thee face to face,
 And met thy cruel eye and cloudy brow;
 But thy soul-withering glance I fear not now—
 For dread to prouder feelings doth give place
 Of deep abhorrence! Scorning the disgrace
 Of slavish knees that at thy footstool bow,
 I also kneel—but with far other vow
 Do hail thee and thy herd of hirelings base:—
 I swear, while life-blood warms my throbbing veins,
 Still to oppose and thwart, with heart and hand,
 Thy brutalizing sway—till Afric's chains
 Are burst, and Freedom rules the rescued land,—
 Trampling Oppression and iron rod:
Such is the vow I take—so help me God!

—W. L. Garrison, *Works* (Boston, 1905), pp. 70-73.

The constitution of the American Antislavery Society was:

Whereas, the Most High God "hath made of one blood all nations of men to dwell on all the face of the earth," and hath commanded them to love their neighbors as themselves; and whereas, our National Existence is based on this principle, as recognized in the Declaration of Independence, "that all mankind are created equal, and that they are endowed by their Creator with certain inalienable rights, among which are life, liberty, and the pursuit of happiness"; and whereas, after the lapse of nearly sixty years, since the faith and honor of the American people were pledged to this avowal, before Almighty God and the World, nearly one-sixth part of the nation are held in bondage by their fellow-citizens; and whereas, Slavery is contrary to the principles of natural justice, of our republican form of government, and of the Christian religion, and is destructive of the prosperity of the country, while it is endangering the peace, union, and liberties of the States; and whereas, we believe it the duty and interest of the masters immediately to emancipate their slaves, and that no scheme of expatriation, either voluntary or by compulsion, can remove this great and increasing evil; and whereas, we believe that it is practicable, by appeals to the consciences, hearts, and interests of the people, to awaken a public sentiment throughout the nation that will be opposed to the continuance of Slavery in any part of the Republic, and by effecting the speedy abolition of Slavery, prevent a general convulsion; and whereas, we believe we owe it to the oppressed, to our fellow-citizens who hold slaves, to our whole country, to posterity, and to God, to do all that is lawfully in our power to bring about the extinction of Slavery, we do hereby agree, with a prayerful reliance on the Divine aid, to form ourselves into a society, to be governed by the following Constitution:

Article I.—This Society shall be called The American Antislavery Society.

Article II.—The objects of this Society are the entire abolition of slavery in the United States. While it admits that each State, in which Slavery exists, has, by the Constitution of the United States, the exclusive right to *legislate* in regard to its abolition in said State, it shall aim to convince all our fellow-citizens, by arguments addressed to their understandings and consciences, that Slaveholding is a heinous crime in the sight of God, and that the duty, safety, and best interests of all concerned, require its *immediate abandonment*, without expatriation. The Society will also endeavor, in a constitutional way, to influence Congress to put an end to the domestic Slave trade, and to abolish Slavery in all those portions of our common country which come under its control, especially in the District of Columbia,—and likewise to prevent the extension of it to any State that may be hereafter admitted to the Union.

Article III.—This Society shall aim to elevate the character and condition of the people of color, by encouraging their intellectual, moral, and religious improvement, and by removing public prejudice, that thus they may, according to their intellectual moral worth, share

an equality with the whites, of civil and religious privileges; but this Society will never in any way countenance the oppressed in vindicating their rights by resorting to physical force.

Article IV.—Any person who consents to the principles of this Constitution, who contributes to the funds of this Society, and is not a Slaveholder, may be a member of this Society, and shall be entitled to vote at the meetings.

The text is in a pamphlet, entitled *Platform of the American Anti-slavery Society and Its Auxiliaries* (New York, 1855), pp. 3, 4. The fullest account of the convention is in *William Lloyd Garrison: Story of His Life Told by His Children*, I, pp. 392-415, where is also a copy of the Declaration. The Declaration is also in the pamphlet above cited. For Whittier's account, see *Atlantic Monthly*, Vol. XXXIII, pp. 166-172. (February, 1874.)

This appeal of a Southern Matron for patience is a case in evidence of the thinking element in the South:

Shut your eyes no longer, my countrymen—the Union is threatened; and all the blessings it confers, and which our fathers suffered and died to attain, must perish with it. Scorn not the feeble voice of a woman, when she calls on you to awake to your danger, ere it be forever too late. We are told that the citizens of the North would arouse our slaves to exert their physical force against us—but we cannot, we will not believe the foul, shocking, unnatural tale. What! have the daughters of the South inflicted such injuries on their Northern brethren, as to render them objects of their deadly, exterminating hate? Have helpless age, smiling infancy, virgin purity no claims on the generous, the highminded and the brave? Would they introduce the serpents of fear and withering anxiety into the Edens of domestic bliss; bathe our peaceful hearths with blood, and force us to abhor those ties which now unite us as one people, and which we so lately taught our sons to regard as our pride? We cannot believe it. We cannot be so unjust to the enlightened and humane citizens of the Northern States, as to suppose for a moment that they approve of the course pursued by those reckless agitators who seek to inflict such cruel calamities on the South. The poor slave himself merits not at their hands the mischief and woe which his mistaken advocates would heap on his devoted head; for even they cannot imagine that an exertion of physical force on their part could result in aught but his destruction. No—the Northern people are too well acquainted with historical facts, to condemn us for evils which we deprecated as warmly as themselves, but which were ruthlessly imposed on us by the power of Great Britain.

So far from condemning, they must sympathize with us; for they well know that slavery was forced upon us, and that as early as 1760 the Southern colonies earnestly sought to avert it by passing acts imposing duties on slaves, and even prohibiting their importation. In spite of sectional prejudices (alas, too often fostered for the worst ends by the unprincipled and ambitious)—in spite of conflicting in-

terests, the people of the North are our brethren. Together our fathers shared many a peril. Side by side, they fought and bled in defense of their common country. Their united wisdom was exerted to form our glorious Constitution, and these republican institutions, which so justly are our boast, and the safeguard of our liberties. Would the sons overthrow the noble fabric their fathers assisted to rear, even now, when towering aloft in its majesty and beauty, it attracts the admiration of the world?—We cannot believe they are prepared for so suicidal an act. The States are all more or less dependent on each other. Let one portion be weakened and depressed, the whole must ultimately suffer. Oh! that a spirit of compromise, forbearance, and brotherly love could be infused into our councils, and animate the bosoms of our public men. Then the voice of contention would be hushed into silence. The insidious treachery of the incendiary would meet the contempt it merits, and factious demagogues would shrink abashed beneath the deep, stern voice of a nation's censure. Then the daughters of America could look joyfully on their sons and indulge the proud hope that they and their children would live and die the free and happy citizens of the great, flourishing and United States of America.

Deluded emancipators of the North, we now appeal to you! We deprecate slavery as much as you. We as ardently desire the liberty of the whole human race; but what can we do? The slow hand of time must overcome these difficulties now insurmountable. An evil, the growth of ages, cannot be remedied in a day. Our virtuous and enlightened men will doubtless effect much by cautious exertion, if their efforts are not checked by your rash attempts to dictate on a subject on which it is impossible that you can form a correct judgment. Forbear your inflammatory addresses. They but rivet the fetters of the slaves, and render them ten thousand times more galling. You sacrifice his happiness, as well as that of his owner, for, by rendering him an object of suspicion and alarm you deprive him of the regard, confidence, and, I may add, with the utmost truth, the affection of his master. You render a being now light-hearted and joyous, moody, wretched—yes, hopelessly wretched. You wreak on the innocent and helpless, who, had they the will, possess not the power to bid the slave be free from all his imagined wrongs. You agonize gentle bosoms, which glow with Christian charity towards the whole human race, of whatever color they may be. Fearful forebodings mingle with all a deep, imperishable love, as the matron bends over the infant that smiles in her face, and with more shuddering horror, she trembles as she gazes on the daughters, whose youthful beauty, goodness and grace shed the sunshine of joy and hope over the winter of life. I appeal to you as Christians, as patriots, as men, generous, highminded men, to forbear. By all you hold sacred—by your own feelings or the wives of your bosom and the children of your love, pause and reflect on the mischief and woe you seek to inflict on both the white and colored population of the Southern States. . . .

“A Southern Nation,” *The Colonizationist* (Boston, 1834), 75-77.

The following speech of John Quincy Adams shows his later attitude on slavery and the like :

The inconsistency of the institution of domestic slavery with the principles of the Declaration of Independence was seen and lamented by all the Southern patriots of the Revolution; by no one with deeper and more unalterable conviction than by the author of the Declaration himself. No insincerity or hypocrisy can fairly be laid to their charge. Never from *their* lips was heard one syllable of attempt to justify the institution of slavery. They universally considered it as a reproach fastened upon them by the unnatural step-mother country; and they saw that, before the principles of the Declaration of Independence, slavery, in common with every other mode of oppression, was destined sooner or later to be banished from the earth. Such was the undoubting conviction of Jefferson to his dying day. In the memoir of his life, written at the age of seventy-seven, he gave to his countrymen the solemn and emphatic warning that the day was not distant when they *must* hear and adopt the general emancipation of their slaves. "Nothing is more certainly written," said he, "in the book of fate, than that these people are to be free. My countrymen! It is written in a better volume than the book of fate; it is written in the laws of Nature and of Nature's God."

We are told, indeed, by the learned doctors of the nullification school, that color operates as a forfeiture of the rights of human nature; that a dark skin turns a man into a chattel; that crispy hair transforms a human being into a four-footed beast. The master-priest informs you that slavery is consecrated and sanctified by the Holy Scriptures of the Old and New Testament; that Ham was the father of Canaan, and all his posterity were doomed, by his own father, to be hewers of wood and drawers of water to the descendants of Shem and Japhet; that the native Americans of African descent are the children of Ham, with the curse of Noah still fastened upon them; and the native Americans of European descent are children of Japhet, pure Anglo-Saxon blood, born to command, and to live by the sweat of another's brow. The master-philosopher teaches you that slavery is no curse, but a blessing! that Providence—Providence!—has so ordered it that this country should be inhabited by two races of men,—one born to wield the scourge, and the other to bear the record of its stripes upon his back; one to earn, through a toilsome life, the other's bread, and to feed him on a bed of roses; that slavery is the guardian and promoter of wisdom and virtue; that the slave, by laboring for another's enjoyment, learns disinterestedness and humility; that the master, nurtured, clothed, and sheltered, by another's toils, learns to be generous and grateful to the slave, and sometimes to feel for him as a father for his child; that, released from the necessity of supplying his own wants, he acquires opportunity of leisure to improve his mind, to purify his heart, to cultivate his taste; that he has time on his hands to plunge into the depths of philosophy, and to soar to the clear empyrean or seraphic morality. The master-statesman—ay, the statesman in the land

of the Declaration of Independence, in the halls of national legislation, with the muse of history recording his words as they drop from his lips, with the colossal figure of American Liberty leaning on a column entwined with the emblem of eternity over his head, with the forms of Washington and Lafayette speaking to him from the canvas—turns to the image of the father of his country, and, forgetting that the last act of his life was to emancipate his slaves, to bolster up the cause of slavery, says, “*That man was a slaveholder.*”

My countrymen! these are the tenets of the modern nullification school. Can you wonder that they shrink from the light of free discussion—that they skulk from the grasp of freedom and of truth? Is there among you one who hears me, solicitous above all things for the preservation of the Union so truly dear to us—of that Union proclaimed in the Declaration of Independence—of that Union never to be divided by any act whatever—and who dreads that the discussion of the merits of slavery will endanger the continuance of the Union? Let him discard his terrors, and be assured that they are no other than the phantom fears of nullification; that, while doctrines like these are taught in her schools of philosophy, preached in her pulpits, and avowed in her legislative councils, the free, unrestrained discussion of the rights and wrongs of slavery, far from endangering the Union of these States, is the only condition upon which that Union can be preserved and perpetuated. What! are you to be told, with one breath, that the transcendent glory of this day consists in the proclamation that all lawful government is founded on the inalienable rights of man, and, with the next breath, that you must not whisper this truth to the winds, lest they should taint the atmosphere with freedom, and kindle the flame of insurrection? Are you to bless the earth beneath your feet because she spurns the footsteps of a slave, and then to choke the utterance of your voice lest the sound of liberty should be reëchoed from the palmetto groves, mingled with the discordant notes of disunion? No! no! Freedom of speech is the only safety-valve which, under the high pressure of slavery, can preserve your political boiler from a fearful and fatal explosion. Let it be admitted that slavery is an institution of internal police, exclusively subject to the separate jurisdiction of the States where it is cherished as a blessing, or tolerated as an evil as yet irremediable. But let that slavery which intrenches itself within the walls of her own impregnable fortress not sally forth to conquest over the domain of freedom. Intrude not beyond the hallowed bounds of oppression; but, if you have by solemn compact doomed your ears to hear the distant clanking of the chain, let not the fetters of the slave be forged afresh upon your own soil; far less permit them to be riveted upon your own feet. Quench not the spirit of freedom. Let it go forth, not in panoply of fleshly wisdom, but with the promise of peace, and the voice of persuasion, clad in the whole armor of truth, conquering and to conquer.

Josiah Quincy, *Memoir of the Life of John Quincy Adams* (Boston, 1858), 272-275.

In the following speech Joshua R. Giddings attacked the policy of yielding ground to slavery :

It is well known, Mr. Chairman, that, since the formation of this confederacy, there has been a supposed conflict between the southern and the northern States. I do not say that the conflict is *real*; I only say that, in the minds of the people, both North and South, and in this hall, such a conflict exists. This has given rise to a difference of policy in our national councils. I refer to the tariff in particular, as being a favorite measure of the North, while free trade is advocated more generally by the South. I refer also to our harbor improvements, and the improvement of our river navigation, as another measure in which the Northwest and West have felt great interest, and to which the South have been constantly opposed. But so equally balanced has been the political power, between these opposing interests, that for five years past our lake commerce has been entirely abandoned; and such were the defects of the tariff, that for many years our revenues were unequal to the support of government.

By the fixed order of nature's law, our population at the North has increased so much faster than it has in the slave States, that under the late census the North and West hold the balance of political power; and at the present session we have passed through this body a bill for the protection of our lake and river commerce, which awaits the action of the Senate to become a law. But let us admit Texas, and we shall place the balance of power in the hands of Texas. They, with the southern States, will control the policy and the destiny of this nation; our tariff will then be held at the will of the Texan advocates of free trade.

Are our friends of the North prepared to deliver over this policy to the people of Texas? Are the liberty-loving democrats of Pennsylvania ready to give up the tariff? To strike off all protection from the articles of iron and coal and other productions of that State, in order to purchase a slave-market for their neighbors, who, in the words of Thomas Jefferson Randolph, "breed men for the market like oxen for the shambles?"

I do not argue the policy of protecting our American manufactures. I only say, that at this time, New England and the free States generally are in favor of it, while the slave States are equally opposed to it. And I ask are the mechanics and manufacturers of the North prepared to abandon their employments, in order that slave-markets may be established in Texas, and a brisk traffic in bodies, the flesh and blood of our southern population may be maintained? Are the farmers of the West, of Ohio, Indiana, and Illinois, prepared to give up the sale of their beef, pork, and flour, in order to increase the profits of those who raise children for sale, and deal in the bodies of women? Are the free States prepared to suspend their harbor and river improvements for the purpose of establishing this slave-trade with Texas, and to perpetuate slavery therein?

But, if Texas be admitted to the Union, it is to be a slave-holding State, out of which several States are hereafter to be ad-

mitted, with the advantages over our free States of holding a representation on this floor, and a vote in the election of president and vice-president, and in the administration of the federal government, in proportion to the number of slaves they shall hold in bondage. In other words, their influence on all these subjects is to be proportioned to their contempt of liberty. The Texan, who holds five slaves, is to wield an influence over our national interests equal to four of our northern freemen. If each holds fifty slaves, his influence will be equal to that of *thirty-one* of the independent electors of the free States. I ask the learned gentleman from Indiana (Mr. Owen) if he really estimates the political worth of his constituents so low as to require thirty-one of them to form an aggregate of political influence equal to that of the piratical owner of fifty "human chattels" in Texas? Or does he estimate his own political worth at one-fourth part of that which he attaches to the holder of five slaves in Texas? I wish gentlemen here would speak out, and let us know the real estimate which they put upon the moral and political worth of northern men? Would to God I were able to speak to every man of every party, north of Mason and Dixon's Line. I would demand of them as *men*, as *freemen*, to come forward, and let the country understand whether any one of them is willing thus to degrade himself; or whether any one of them is willing to be thus degraded by his representatives in this hall. This proposition, come from whom it may, from persons high in office, or from those *wishing* to be high in office, is insulting to northern feeling and northern honor. Sir, why not propose at once that our people shall surrender themselves as slaves to the Texan planters? Why not advise the people of our free States at once to leave their homes, to go to Texas, and become the voluntary "hewers of wood and drawers of water" to those fugitive criminals, who, within the last fifteen years, were driven from the United States to avoid punishment for their crimes? . . .

Joshua R. Giddings, *Speeches in Congress* (Boston, 1853), 104-106.

As the following extract from his speech shows, Sumner believed in the equality of all men before the law. He said :

The way is now prepared to consider the nature of Equality, as secured by the Constitution of Massachusetts. The Declaration of Independence, which followed the French Encyclopedia and the political writings of Rousseau, announces among self-evident truths, "*that all men are created equal; that they are endowed by their Creator with certain unalienable rights; that among these are life, liberty, and the pursuit of happiness.*" The Constitution of Massachusetts repeats the same truth in a different form, saying, in its first article: "*All men are born free and equal, and have certain natural essential, and unalienable rights, among which may be reckoned the right of enjoying and defending their lives and liberties.*" Another article explains what is meant by Equality, saying: "No man, nor corporation or association of men, have any other title

to obtain advantages, or particular and exclusive privileges, distinct from those of the community, that what arises from the consideration of services rendered to the public; and this title being in nature neither hereditary, nor transmissible to children, or descendants, or relations by blood, the idea of a man being born a magistrate, law-giver, or judge is absurd and unnatural." This language, in its natural signification, condemns every form of inequality in civil and political institutions.

These declarations, though in point of time before the ampler declarations of France, may be construed in the light of the latter. Evidently they seek to declare the same principle. They are declarations of *Rights*; and the language employed, though general in character, is obviously limited to those matters within the design of a declaration of *Rights*. And permit me to say, it is a childish sophism to adduce any physical or mental inequality in argument against Equality of Rights.

Obviously, men are not born equal in physical strength or in mental capacity, in beauty of form or health of body. Diversity or inequality in these respects is the law of creation. From this difference springs divine harmony. But this inequality is in no particular inconsistent with complete civil and political equality.

The equality declared by our fathers in 1776, and made the fundamental law of Massachusetts in 1780, was *Equality before the Law*. Its object was to efface all political or civil distinctions, and to abolish all institutions founded upon *birth*. "All men are *created* equal," says the Declaration of Independence. "All men are *born* free and equal," says the Massachusetts Bill of Rights. These are not vain words. Within the sphere of their influence, no person can be *created*, no person can be *born* with civil or political privileges not enjoyed equally by all his fellow-citizens; nor can any institution be established, recognizing distinction of birth. Here is the Great Charter of every human being drawing vital breath upon this soil, whatever may be his condition, and whoever may be his parents. He may be poor, weak, humble, or black;—he may be of Caucasian, Jewish, Indian, or Ethiopian race,—he may be of French, German, English, or Irish extraction; but before the Constitution of Massachusetts all these distinctions disappear. He is not poor, weak, humble, or black; nor is he Caucasian, Jew, Indian, or Ethiopian; nor is he French, German, English, or Irish; he is a *MAN*, the equal of all his fellow-men. He is one of the children of the State, which, like an impartial parent, regards all its offsprings with an equal care. To some it may justly allot higher duties, according to higher capacities; but it welcomes all to its equal hospitable board. The State, imitating the divine justice, is no respecter of persons.

Here nobility cannot exist, because it is a privilege from birth. But the same anathema which smites and banishes nobility must also smite and banish every form of discrimination founded on birth,—

"Quamvis ille niger, quamvis tu candidus esses."

Charles Sumner, *Works* (Boston, 1875), II, 340-342.

Voicing a strong protest against the theory that the rightfulness of slavery must not be publicly discussed or questioned, Joshua R. Giddings said:

Sir, certain Senators in the other end of the capitol have for months been endeavoring to convince the people of the necessity of passing the "omnibus bill," as it is called. No arguments could be raised in favor of that measure, for it was not founded on reason. One consideration alone was pressed upon the public mind. The cry was raised that "*the Union was in danger!*" The newspapers here responded, "*the Union is in danger!*" The country press repeated the alarm. The cry was caught up and echoed by every timid, faltering poltroon of the North. Petitions to "*save the Union*" were circulated. Public meetings were held in our commercial cities where Texas scrip was mostly influential, and resolutions were adopted "*to save the Union.*" The supplications were not that we "*may legislate in righteousness,*" deal out justice and mercy to those who are oppressed and degraded by our laws. These were regarded as objects of trifling importance, when compared with the pending danger that *Texas would dissolve the Union.* Indeed, they are never mentioned by our chaplain.

Sir, I am nauseated, sickened at this moral and political effeminaey; this downright cowardice. It is unworthy of American statesmen. Our constituents sent us here to maintain and defend their rights; not to surrender them; not to make ourselves and our people tributary to Texas. In electing us, they had no expectation that we would turn upon them and violently thrust our hands into their pockets and take therefrom ten millions of dollars, and hand it over to the slave-holders of Texas, for territory which belongs to us, and to which Texas never had any title whatever.

Sir, gentlemen here may say what they please; the people have no fears of a dissolution of the Union. They understand this kind of gasconade. The cry of "dissolution" has been the dernier resort of southern men for fifty years, whenever they desired to frighten doughfaces into a compliance with their measures. It may alarm gentlemen here; but I do not think you can find in northern Ohio an equal number of nervous old women or of love-sick girls, who could be moved by it.

Again, it is said that we must stop this agitation in relation to slavery! The people see us here passing laws to enslave our fellow men; to sell women in open market; to create a traffic in the bodies of children. They know this to be opposed to the self-evident truth that "all men are created equal," "that governments are constituted to sustain that equality of rights"; and they converse on the subject, examine the reasons on which such traffic is based, and vote for men who will oppose such barbarous practices. This is called *agitation*; and gentlemen here talk of suppressing it by passing such laws as that on your table. This is the manner in which we are to stop the progress of truth; to seal the lips of philanthropists; and to silence the voice of humanity. Yes, Sir, it is gravely proposed

that we should set bounds to the human intellect, and to limit political investigations by statute laws.

Sir, the great founder of our holy religion, when he proclaimed the Heaven-born truths of his Gospel, was denounced as an "agitator." He was arrested, condemned, and executed for asserting truths which the Scribes and Pharisees were too stupid to comprehend. It was done to stop *agitation*; but truth, emanating from "the Holy One," has extended, spread, and progressed, and will "go on conquering and to conquer," in spite of all the political Scribes and Pharisees in Congress, and the quaking and trembling of doughfaces here and elsewhere.

This progress in morals and in political intelligence is in strict accordance with the law of our being, and cannot be prevented. The idea of setting bounds to the human intellect, of circumscribing it by statute law, is preposterous. Why not limit the arts and sciences by conservative legislation, as well as moral and political progress? Why not follow the example of those who attempted to stop the agitation of Galileo, when he proclaimed the truth of our solar system, and the laws by which the planets are retained in their orbits? He caused great agitation, and was excommunicated for his *infidelity*, in thus daring to proclaim truths which the *conservatives* of that age were too ignorant to comprehend. It required two hundred and fifty years for the stupid clergy of that day to understand the truths for which he had been expelled from their Christian fellowship. How long it will require certain theological professors of the present day to comprehend the "self-evident truths" of man's equality, is not yet determined. Or how long it will require our political doctors to comprehend the very obvious fact that an educated and reflecting people *will think and act for themselves*, is yet to be ascertained.

But, if we are to have conservative legislation, let us tear down the telegraphic wires, break up our galvanic batteries, and imprison Morse, and stop all agitation upon the subject of your "magnetic railroads of thought." Lay up your steamboats, place fetters upon your locomotives, convert your railroads into cultivated fields, and erase the name of Fulton from our history. Go down to yonder Institute, drive Page from his laboratory, break in pieces his galvanic engines, and unchain the imprisoned lightning which is there pent up; then pass an act of Congress prohibiting all further agitation on these subjects, and thus carry out your conservative principles, of which some men are continually boasting. . . .

Joshua R. Giddings, *Speeches in Congress* (Boston, 1853), 409-411.

Giving great offense to Jefferson Davis and other Southern friends, William H. Seward spoke thus for *The Higher Law than the Constitution*:

There is another aspect of the principle of compromise which deserves consideration. It assumes that slavery, if not the only institution in a slave State, is at least a ruling institution, and

that this characteristic is recognized by the Constitution. But *slavery* is only *one* of many institutions there. Freedom is equally an institution there. Slavery is only a temporary, accidental, partial, and incongruous one. Freedom, on the contrary, is a perpetual, organic, universal one, in harmony with the Constitution of the United States. The slaveholder himself stands under the protection of the latter, in common with all the free citizens of that state. But it is, moreover, an indispensable institution. You may separate slavery from South Carolina, and the state will still remain; but if you subvert freedom there, the state will cease to exist. But the principle of this compromise gives complete ascendancy in the slave states, and in the Constitution of the United States, to the subordinate, accidental, and incongruous institution, over its paramount antagonist. To reduce this claim of slavery to an absurdity, it is only necessary to add that there are only two states in which slaves are a majority, and not one in which the slaveholders are not a very disproportionate minority.

But there is yet another aspect in which this principle must be examined. It regards the domain only as a possession, to be enjoyed either in common or by partition by the citizens of the old states. It is true, indeed, that the national domain is ours. It is true it was acquired by the valor and with the wealth of the whole nation. But we hold, nevertheless, no arbitrary power over it. We hold no arbitrary authority over anything, whether acquired lawfully or seized by usurpation. The Constitution regulates our stewardship; the Constitution devotes the domain to union, to justice, to defense, to welfare, and to liberty.

But there is a higher law than the Constitution, which regulates our authority over the domain, and devotes it to the same noble purposes. The territory is a part, no inconsiderable part, of the common heritage of mankind bestowed upon them by the Creator of the universe. We are his stewards, and must so discharge our trust as to secure in the highest attainable degree their happiness. How momentous that trust is we may learn from the instructions of the founder of modern philosophy:

"No man," says Bacon, "can by care-taking, as the Scripture saith, add a cubit to his stature in this little model of a man's body; but, in the great frame of kingdoms and commonwealths, it is in the power of princes or estates to add amplitude and greatness to their kingdoms. For, by introducing such ordinances, constitutions, and customs, as are wise, they may sow greatness to their posterity and successors. But these things are commonly not observed, but left to take their chance."

This is a state, and we are deliberating for it, just as our fathers deliberated in establishing the institutions we enjoy. Whatever superiority there is in our condition and hopes over those of any other "kingdom" or "estate" is due to the fortunate circumstance that our ancestors did not leave things to "take their chance," but that they "added amplitude and greatness" to our common-wealth "by introducing such ordinances, constitutions, and customs, as were wise." We in our turn have succeeded to the same responsibilities, and we cannot approach the duty before us

wisely or justly, except we raise ourselves to the great consideration of how we can most certainly "sow greatness to our posterity and successors."

And now the simple, bold, and even awful, question which presents itself to us is this: Shall we, who are founding institutions, social and political, for countless millions; shall we, who know by experience the wise and the just, and are free to choose them, and to reject the erroneous and unjust; shall we establish human bondage, or permit it by our sufferance to be established? Sir, our forefathers would not have hesitated an hour. They found slavery existing here, and they left it only because they could not remove it. There is not only no free State which would now establish it, but there is no slave State, which, if it had had the free alternative as we now have, would have founded slavery. Indeed, our revolutionary predecessors had precisely the same question before them in establishing an organic law under which the states of Ohio, Indiana, Michigan, Illinois, and Wisconsin, have since come into the Union, and they solemnly repudiated and excluded slavery from those states forever. I confess that the most alarming evidence of our degeneracy which has yet been given is found in the fact that we even debate such a question. . . .

The senator proposes to expel me. I am ready to meet that trial, too; and if I shall be expelled, I shall not be the first man subjected to punishment for maintaining that there is a power higher than human law, and that power delights in justice; that rulers, whether despots or elected rulers of a free people, are bound to administer justice for the benefit of society.

William H. Seward, *Works* (N. Y., 1853), I, pp. 74-129.

The following speech from Lincoln exposed the fallacy of the so-called reasonableness of slavery:

Equality in society alike beats inequality, whether the latter be of the British aristocratic sort or of the domestic slavery sort. We know Southern men declare that their slaves are better off than hired laborers among us. How little they know whereof they speak! There is no permanent class of hired laborers amongst us. Twenty-five years ago I was a hired laborer. The hired laborer of yesterday labors on his own account to-day, and will hire others to labor for him to-morrow. Advancement—improvement in condition—is the order of things in a society of equals. As labor is the common burden of our race, so the effort of some to shift their share of the burden onto the shoulders of others is the great durable curse of the race. Originally a curse for transgression upon the whole race, when, as by slavery, it is concentrated on a part only, it becomes the double-refined curse of God upon his creatures.

Free labor has the inspiration of hope; pure slavery has no hope. The power of hope upon human exertion and happiness is wonderful. The slave-master himself has a conception of it, and hence the system of tasks among slaves. The slave whom you cannot drive with the lash to break seventy-five pounds of hemp in a day, if you will ask

him to break a hundred, and promise him pay for all he does over, he will break you a hundred and fifty. You have substituted hope for the rod. And yet perhaps it does not occur to you that to the extent of your gain in the case, you have given up the slave system and adopted the free system of labor.

If A can prove, however, conclusively, that he may of right enslave B, why may not B snatch the same argument and prove equally that he may enslave A? You say A is white and B is black. It is color, then; the lighter having the right to enslave the darker? Take care. By this rule you are to be slave to the first man you meet with a fairer skin than your own. You do not mean color exactly? You mean the whites are intellectually the superiors of the blacks, and therefore have the right to enslave them? Take care again. By this rule you are to be slave to the first man you meet with an intellect superior to your own. But, you say, it is a question of interest, and if you make it your interest you have the right to enslave another. Very well. And if he can make it his interest he has the right to enslave you.

The ant who has toiled and dragged a crumb to his nest will furiously defend the fruit of his labor against whatever robber assails him. So plain that the most dumb and stupid slave that ever toiled for a master does constantly know that he is wronged. So plain that no one, high or low, ever does mistake it, except in a plainly selfish way; for although volume upon volume is written to prove slavery a very good thing, we never hear of the man who wishes to take the good of it by being a slave himself.

Most governments have been based, practically, on the denial of the equal rights of men as I have, in part, stated them; ours began by affirming those rights. They said, some men are too ignorant and vicious to share in government. Possibly so, said we; and, by your system, you would always keep them ignorant and vicious. We proposed to give all a chance; and we expected the weak to grow stronger, the ignorant wiser, and all better and happier together.

We made the experiment, and the fruit is before us. Look at it, think of it. Look at it in its aggregate grandeur, of extent of country, and numbers of population—of ship, and steamboat, and railroad. . . .

Thus we see that the plain, unmistakable spirit of that age toward slavery was hostility to the principles and toleration only by necessity.

But now it is to be transformed into a "sacred right." Nebraska brings it forth, places it on the highroad to extension and perpetuity, and with a pat on its back says to it, "Go, and God speed you." Henceforth it is to be the chief jewel of the nation—the very figure-head of the ship of state. Little by little, but steadily as man's march to the grave, we have been giving up the old for the new faith. Nearly eighty years ago we began by declaring that all men are created equal; but now from that beginning we have run down to the other declaration, that for some men to enslave others is a "sacred right of self-government." These principles cannot stand together. They are as opposite as God and Mammon; and whoever holds to the one must despise the other. When Pettit, in connection

with his support of the Nebraska bill, called the Declaration of Independence "a self-evident lie," he only did what consistency and candor require all other Nebraska men to do. Of the forty-odd Nebraska senators who sat present and heard him, no one rebuked him. Nor am I apprised that any Nebraska newspaper, or any Nebraska orator, in the whole nation has ever rebuked him. If this had been said among Marion's men, Southerners though they were, what would have become of the man who said it? If this had been said to the men who captured André, the man who said it would probably have been hung sooner than André was. If it had been said in old Independence Hall seventy-eight years ago, the very door-keeper would have throttled the man and thrust him into the street. Let no one be deceived. The spirit of seventy-six and the spirit of Nebraska are utter antagonisms; and the former is being rapidly displaced by the latter.

Fellow-countrymen, Americans, South as well as North, shall we make no effort to arrest this? Already the liberal party throughout the world express the apprehension "that the one retrograde institution in America is undermining the principles of progress, and fatally violating the noblest political system the world ever saw." This is not the taunt of enemies, but the warning of friends. Is it quite safe to disregard it—to despise it? Is there no danger to liberty itself in discarding the earliest practice and first precept of our ancient faith? In our greedy chase to make profit of the negro, let us beware lest we "cancel and tear in pieces" even the white man's charter of freedom.

Our republican robe is soiled and trailed in the dust. Let us repurify it. Let us turn and wash it white in the spirit, if not in the blood, of the Revolution. Let us turn slavery from its claims of "moral right" back upon its existing legal rights and its arguments of "necessity." Let us return it to the position our fathers gave it, and there let it rest in peace. Let us readopt the Declaration of Independence, and with it the practices and policy which harmonize with it. Let North and South,—let all Americans—let all lovers of liberty everywhere join in the great and good work. If we do this, we shall not only have saved the Union, but we shall have so saved it that the succeeding millions of free, happy people, the world over, shall rise up and call us blessed to the latest generations.

Abraham Lincoln, *Early Speeches* (N. Y., 1907), 216-264.

Some of the thoughts of *The Irrepressible Conflict of Freedom and Slavery* were:

This African slave system is one which, in its origin and in its growth, has been altogether foreign from the habits of the races which colonized these states and established civilization here. It was introduced on this continent as an engine of conquest, and for the establishment of monarchial power, by the Portuguese and the Spaniards, and was rapidly extended by them all over South America, Central America, Louisiana, and Mexico. Its legitimate fruits are

seen in the poverty, imbecility, and anarchy which now pervade all Portuguese and Spanish America. The free-labor system is of German extraction, and it was established in our country by emigrants from Sweden, Holland, Germany, Great Britain, and Ireland. We justly ascribe to its influences the strength, wealth, greatness, intelligence, and freedom, which the whole American people now enjoy. One of the chief elements of the value of human life is freedom in the pursuit of happiness. The slave system is not only intolerable, unjust, and inhuman, toward the laborer, whom, only because he is a laborer, it loads down with chains and converts into merchandise, but is scarcely less severe upon the freeman, to whom, only because he is a laborer from necessity, it denies facilities for employment, and whom it expels from the community because it cannot enslave and convert into merchandise also. It is necessarily improvident and ruinous, because, as a general truth, communities prosper and flourish, or droop and decline, in just the degree that they practice or neglect to practice the primary duties of justice and humanity. The free-labor system conforms to the divine law of equality, which is written in the hearts and consciences of men, and therefore is always and everywhere beneficent.

The slave system is one of constant danger, distrust, suspicion, and watchfulness. It debases those whose toil alone can produce wealth and resources for defense, to the lowest degree of which human nature is capable, to guard against mutiny and insurrection, and thus wastes energies which otherwise might be employed in national development and aggrandizement.

The free-labor system educates all alike, and by opening all the fields of industrial employment and all the departments of authority, to the unchecked and equal rivalry of all classes of men, at once secures universal contentment, and brings into the highest possible activity all the physical, moral, and social energies of the whole state. In states where the slave system prevails, the masters, directly or indirectly, secure all the political power, and constitute a ruling aristocracy. In states where the free-labor system prevails, universal suffrage necessarily obtains, and the state inevitably becomes, sooner or later, a republic or democracy. . . .

Hitherto the two systems have existed in different states, but side by side within the American Union. This has happened because the Union is a confederation of states. But in another aspect the United States constitute only one nation. Increase of population, which is filling the states out to their very borders, together with a new and extended network of railroads and other avenues, and an internal commerce which daily becomes more intimate, is rapidly bringing the states into a higher and more perfect social unity or consolidation. Thus, these antagonistic systems are continually coming into closer contact, and collision results.

Shall I tell you what this collision means? They who think that it is accidental, unnecessary, the work of interested or fanatical agitators, and therefore ephemeral, mistake the case altogether. It is an *irrepressible conflict* between opposing and enduring forces, and it means that the United States must and will, sooner or later, become either entirely a slave-holding nation or entirely a free-labor

nation. Either the cotton or rice fields of South Carolina and the sugar plantations of Louisiana will ultimately be tilled by free labor, and Charleston and New Orleans, become marts of legitimate merchandise alone, or else the rye-fields and wheat-fields of Massachusetts and New York must again be surrendered by their farmers to slave culture and to the production of slaves, and Boston and New York become once more markets for trade in the bodies and souls of men. It is the failure to apprehend this great truth that induces so many unsuccessful attempts at final compromises between the slave and free states, and it is the existence of this great fact that renders all such pretended compromises, when made, vain and ephemeral. . . .

At last, the Republican party has appeared. It avows, now, as the Republican party of 1800 did, in one word, its faith and its works, 'Equal and exact justice to all men.' Even when it first entered the field, only half organized, it struck a blow which only just failed to secure complete and triumphant victory. In this, its second campaign, it has already won advantages which render that triumph now both easy and certain.

The secret of its assured success lies within that very characteristic which, in the mouth of scoffers, constitutes its great and lasting imbecility and reproach. It lies in the fact that it is a party of one idea; but that is a noble one—an idea that fills and expands all generous souls; the idea of equality—the equality of all men before human tribunals and human laws, as they all are equal before the Divine tribunal and Divine laws.

I know, and you know, that a revolution has begun. I know, and all the world knows, that revolutions never go backward. Twenty Senators and a hundred Representatives proclaim boldly in Congress to-day sentiments and opinions and principles of freedom which hardly so many men, even in this free state, dared to utter in their own homes twenty years ago. While the Government of the United States under the conduct of the Democratic party, has been all that time surrendering one plain and castle after another to slavery, the people of the United States have been no less steadily and perseveringly gathering together the forces with which to recover back again all the fields and all the castles which have been lost, and to confound and overthrow, by one decisive blow, the betrayers of the Constitution and freedom forever.

William H. Seward, *The Irrepressible Conflict: A Speech Delivered at Rochester*, Oct. 25, 1858 (no title page, New York, 1858), 1-7 *passim*.

This review of the struggle by Senator Benjamin F. Wade, an Ohio antislavery senator who frequently assailed slavery, shows how the sentiment in the South had drifted toward secession:

There is no principle held to-day by this great Republican party that has not had the sanction of your Government in every depart-

ment for more than seventy years. You have changed your opinions. We stand where we used to stand. That is the only difference. . . . Sir, we stand where Washington stood, where Jefferson stood, where Madison stood, where Monroe stood. We stand where Adams and Jackson and even Polk stood. That revered statesman, Henry Clay, of blessed memory with his dying breath asserted the doctrine that we hold to-day. . . . As to compromises, I had supposed that we were all agreed that the day of compromises was at an end. The most solemn compromises we have ever made have been violated without a *whereas*. Since I have had a seat in this body, one of considerable antiquity, that had stood for more than thirty years, was swept away from your statute books. . . . We nominated our candidates for President and Vice-President, and you did the same for yourselves. The issue was made up and we went to the people upon it. . . . And we beat you upon the plainest and most palpable issue that ever was presented to the American people, and one that they understood the best. There is no mistaking it; and now when we come to the capitol, I tell you that our President and our Vice-President must be inaugurated and administer the government as all their predecessors have done. Sir, it would be humiliating and dishonorable to us if we were to listen to a compromise (only) by which he who has the verdict of the people in his pocket should make his way to the Presidential chair. When it comes to that you have no government. . . . If a State secedes, although we will not make war upon her, we cannot recognize her right to be out of the Union, and she is not out until she gains the consent of the Union itself; and the chief magistrate of the nation, be he who he may, will find under the Constitution of the United States that it is his sworn duty to execute the law in every part and parcel of this Government; that he cannot be released from that obligation. . . . Therefore, it will be incumbent on the chief magistrate to proceed to collect the revenue of ships entering their ports precisely in the same way and to the same extent that he does now in every other State of the Union. . . . What must she do? If she is contented to live in this equivocal state, all would be well perhaps, but she could not live there. No people in the world could live in that condition. What will they do? They must take the initiative and declare war upon the United States; and the moment that they levy war, force must be met by force; and they must, therefore, hew out their independence by violence and war. There is no other way under the Constitution, that I know of whereby a chief magistrate of any politics could be released from this duty: If this State, though seceding, should declare war against the United States, I do not suppose there is a lawyer in this body but what would say that the act of levying war is treason against the United States. That is where it results. We might just as well look the matter right in the face. . . .

I say, sir, I stand by the Union of these States. Washington and his compatriots fought for that good, old flag. It shall never be hauled down, but shall be the glory of the Government to which I belong, as long as my life shall continue. . . . It was my protector in

infancy, and the pride and glory of my riper years; and although it may be assailed by traitors on every side, by the grace of God, under its shadow I will die.

Nicolay and Hay, *Abraham Lincoln: A History* (New York, 1890), Ch. II, pp. 412-414.

These last words of John Brown show exactly how radical the antislavery movement had become:

I have, may it please the Court, a few words to say.

In the first place, I deny everything but what I have all along admitted—the design on my part to free the slaves. I intended certainly to have made a clear thing of that matter, as I did last winter, when I went into Missouri, and there took slaves without the snapping of a gun on either side, moved them through the country, and finally left them in Canada. I designed to have done the same thing again, on a larger scale. That was all I intended. I never did intend murder, or treason, or the destruction of property, or to excite or incite slaves to rebellion, or to make insurrection.

I have another objection: and that is, it is unjust that I should suffer such a penalty. Had I interfered in the manner which I admit, and which I admit has been fairly proved,—for (I admire the truthfulness and candor of the greater portion of the witnesses who have testified in this case)—had I so interfered in behalf of the rich, the powerful, the intelligent, the so-called great, or in behalf of any of their friends, either father, mother, sister, brother, or wife, or children, or any of that class, and suffered and sacrificed what I have in this interference, it would have been all right, and every man in this Court would have deemed it an act worthy of reward rather than punishment.

This Court acknowledges, as I suppose, the validity of the Law of God. I see a book kissed here which I suppose to be the Bible, or at least, the New Testament. That teaches me that all things whatsoever I would that men should do unto me I should do even so to them. It teaches me further, to “remember them that are in bonds as bound with them.” I endeavored to act up to that instruction. I say, I am yet too young to understand that God is any respecter of persons. I believe that to have interfered as I have done, in behalf of His despised poor, was not wrong, but right. Now, if it is deemed necessary that I should forfeit my life for the furtherance of the ends of justice, and mingle my blood further with the blood of my children, and with the blood of millions in this slave country whose rights are disregarded by wicked, cruel, and unjust enactments—I submit; so let it be done.

Let me say one word further:

I feel entirely satisfied with the treatment I have received on my trial. Considering the circumstances, it has been more generous than I expected. But I feel no consciousness of guilt. I have stated from the first what was my intention and what was not. I never had any design against the life of any person, nor any disposition to com-

mit treason, or excite slaves to rebel, or make any general insurrection. I never encouraged any man to do so, but always discouraged any idea of that kind.

Let me say, also, a word in regard to the statements made by some of those connected with me. I hear it has been stated by some of them that I have induced them to join me. But the contrary is true. I do not say this to injure them, but as regretting their weakness. There is not one of them but joined me of his own accord, and the greater part at their own expense. A number of them I never saw, and never had a word or conversation with, till the day they came to me, and that was for the purpose I have stated.

Now I have done.

James Redpath, *The Public Life of Capt. John Brown* (Boston, 1860), pp. 340-342.

The Act to Establish a Bureau for the Relief of Freedmen and Refugees was:

Be it enacted . . . That there is hereby established in the War Department, to continue during the present war of rebellion, and for one year thereafter, a bureau of refugees, freedmen, and abandoned lands, to which shall be committed, as hereinafter provided, the supervision and management of all abandoned lands, and the control of all subjects relating to refugees and freedmen from rebel states, or from any district of country within the territory embraced in the operations of the army, under such rules and regulations as may be prescribed by the head of the bureau and approved by the President. The said bureau shall be under the management and control of a commissioner to be appointed by the President, by and with the advice and consent of the Senate, . . . And the commissioner and all persons appointed under this act, shall, before entering upon their duties, take oath of office prescribed in . . . (the act of July 2, 1862). . . .

Sec. 2. *And be it further enacted*, That the Secretary of War may direct such issues of provisions, clothing, and fuel, as he may deem needful for the immediate and temporary shelter and supply of destitute and suffering refugees and freedmen and their wives and children, under such rules and regulations as he may direct.

Sec. 3. *And be it further enacted*, That the President may, by and with the advice and consent of the Senate, appoint an assistant commissioner for each of the states declared to be in insurrection, not exceeding ten in number, who shall, under the direction of the commissioner, aid in the execution of the provisions of this act. . . . And any military officer may be detailed and assigned to duty under this act without increase of pay or allowances. The commissioner shall, before the commencement of each regular session of Congress, make full report of his proceedings with exhibits of the state of his accounts to the President, who shall communicate the same to Congress, and shall also make special reports whenever required to do so by the President or either house of congress; and the assistant

commissioners shall make quarterly reports of their proceedings to the commissioner, and also such other special reports as from time to time may be required.

Sec. 4. *And be it further enacted*, That the commissioner, under the direction of the President, shall have authority to set apart, for the use of loyal refugees and freedmen, such tracts of land within the insurrectionary states as shall have been abandoned, or to which the United States shall have been abandoned, or to which the United States shall have acquired title by confiscation or sale, or otherwise, and to every male citizen, whether refugee or freedman, as aforesaid, there shall be assigned not more than forty acres of such land, and the person to whom it was so assigned shall be protected in the use and enjoyment of the land for the term of three years at an annual rent not exceeding six per centum upon the value of such land, as it was appraised by the state authorities in the year eighteen hundred and sixty, for the purpose of taxation, and in case no such appraisal can be found, then the rental shall be based upon the estimated value of the land in said year, to be ascertained in such manner as the commissioner may by regulation prescribe. At the end of said term, or at any time during said term, the occupants of any parcels so assigned may purchase the land and receive such title thereto as the United States can convey, upon paying therefor the value of the land, as ascertained and fixed for the purpose of determining the annual rent aforesaid.

Sec. 5. *And be it further enacted*, That all acts and parts of acts inconsistent with the provisions of this act, are hereby repealed.

Approved, March 3, 1865.

Text in U. S. Statutes at Large, XIII, 507-509. For the proceedings see the *House and Senate Journals*, 38th Congress, 1st and 2d Sess., and the *Cong. Globe*. On the work of the bureau see *Senate Exec. Doc. 28*, 38th Cong., 2d Sess.; *House Exec. Docs. 11, 70, and 120*, 39th Cong., 1st Sess.; *House Exec. Doc. 7*, 39th Cong., 2d Sess.; *House Report 30*, 40th Cong., 2d Sess.; *House Exec. Doc. 329, ibid.*; *House Exec. Doc. 142*, 41st Cong., 2d Sess.; *House Misc. Doc. 87*, 42d Cong., 3d Sess.; *House Exec. Doc. 100*, 43d Cong., 1st Sess.; *House Exec. Doc. 144*, 44th Cong., 1st Sess. On the condition of Freedmen see *Senate Exec. Doc. 53*, and *Senate Report 25*, 38th Cong., 1st Sess.; *House Exec. Doc. 118*, 39th Cong., 1st Sess. Southern State legislation respecting freedmen is summarized in McPherson, *Reconstruction*, 29-44. See also Cox, *Three Decades*, chap. 25.

It may be interesting to note Abraham Lincoln's prophetic protest against lynch law uttered in 1830. He said:

In the great journal of things happening under the sun, we, the American people, find our account running under date of the nineteenth century of the Christian era. We find ourselves in the peaceful possession of the fairest portion of the earth as regards extent of territory, fertility of soil, and salubrity of climate. We find

ourselves under the government of a system of political institutions conducing more essentially to the ends of civil and religious liberty than any of which the history of former times tells us. We, when mounting the stage of existence, found ourselves the legal inheritors of these fundamental blessings. We toiled not in the acquirement or establishment of them; they are a legacy bequeathed us by a once hardy, brave, and patriotic, but now lamented and departed, race of ancestors. . . .

At what point then is the approach of danger to be expected? I answer, if it ever reach us it must spring up amongst us; it cannot come from abroad. If destruction be our lot we must ourselves be its author. We must live through all time or die by suicide.

I hope I am over wary; but if I am not, there is even now something of ill omen amongst us. I mean the increasing disregard for law which pervades the country—the growing disposition to substitute the wild and furious passions in lieu of the sober judgment of courts, and the worse than savage mobs for the executive ministers of justice. This disposition is awfully fearful in any community; and that it now exists in ours, though grating to our feelings to admit, it would be a violation of truth and an insult to our intelligence to deny. . . .

Turn then to that horror-striking scene at St. Louis. A single victim only was sacrificed there. This story is very short, and is perhaps the most highly tragic of anything of its length that has ever been witnessed in real life. A mulatto man by the name of McIntosh was seized in the street, dragged to the suburbs of the city, chained to a tree, and actually burned to death; and all within a single hour from the time he had been a freeman attending to his own business and at peace with the world.

Such are the effects of mob law, and such are the scenes becoming more and more frequent in this land so lately famed for love of law and order, and the stories of which have even now grown too familiar to attract anything more than an idle remark.

But you are perhaps ready to ask, "What has this to do with the perpetuation of our political institutions?" I answer, "It has much to do with it." Its direct consequences are, comparatively speaking, but a small evil, and much of its danger consists in the proneness of our minds to regard its direct as its only consequences. . . . But the example in either case was fearful. When men take it in their heads today to hang gamblers or burn murderers, they should recollect that in the confusion usually attending such transactions they will be as likely to hang or burn some one who is neither a gambler nor a murderer as one who is, and that, acting upon the example they set, the mob of tomorrow may, and probably will, hang or burn some of them by the very same mistake. And not only so; the innocent, those who have ever set their faces against violations of law in every shape, alike with the guilty fall victims to the ravages of mob law; and thus it goes on, step by step, till all the walls erected for the defense of the persons and property of individuals are trodden down and disregarded. But all this, even, is not the full extent of the evil. By such examples, by instances of the perpetrators of such acts going unpunished, the lawless in spirit are

encouraged to become lawless in practice; and having been used to no restraint but dread of punishment, they thus become absolutely unrestrained. . . . Thus, then, by the operation of this mobocrat spirit which all must admit is now abroad in the land, the strongest bulwark of any government, and particularly of those constituted like ours, may effectually be broken down and destroyed—I mean the attachment of the people. Whenever this effect shall be produced among us; whenever the vicious portion of (*our*) population shall be permitted to gather in bands of hundreds and thousands, and burn churches, ravage and rob provision stores, throw printing presses into rivers, shoot editors, and hang and burn obnoxious persons at pleasure and with impunity, depend upon it, this government cannot last. By such things the feelings of the best citizens will become more or less alienated from it, and under such circumstances, men of sufficient talent and ambition will not be wanting to seize the opportunity, strike the blow, and overturn that fair fabric which for the last half century has been the fondest hope of the lovers of freedom throughout the world. . . .

The question recurs, "How shall we fortify against it?" The answer is simple. Let every American, every lover of liberty, every well-wisher to his posterity swear by the blood of the Revolution never to violate in the least particular the laws of the country, and never to tolerate their violation by others. As the patriots of seventy-six did to the support of the Declaration of Independence, so to the support of the Constitution and laws let every American pledge his life, his property, and his sacred honor—let every man remember that to violate the law is to trample on the blood of his father, and to tear the charter of his own and his children's liberty. Let reverence for the laws be breathed by every American mother to the lisping babe that prattles on her lap; let it be taught in schools, in seminaries, and in colleges; let it be written in primers, spelling-books, and in almanacs; let it be preached from the pulpit, proclaimed in legislative halls, and enforced in courts of justice. And, in short, let it become the political religion of the nation; and let the old and the young, the rich and the poor, the grave and the gay of all sexes and tongues and colors and conditions, sacrifice unceasingly upon its altars. While ever a state of feeling such as this shall universally or even very generally prevail throughout the nation, vain will be every effort, and fruitless every attempt, to subvert our national freedom. . . .

A, Lincoln, *Early Speeches* (N. Y., 1907), 14-21 *passim*.

INDEX

- Abbott, A. R., a Negro surgeon, 234
- Abdy's observation of interbreeding, 111
- Abolition, 169-181; in the South, 182-183; quelled in the South, 187; rise of, in the West, 182-183
- Abolitionists, achievements of, 188-190
- Achievements, of Negroes unusual, 291-292
- Achievements of Negroes in freedom, 280-301
- Adams, Henry, a leader of Negro migrants, 263-264
- Adams, John, fear of, 57
- Adams, John Quincy, the champion of free speech, 195-198; not an antislavery man, 196; comment of, on the Missouri Compromise, 343-344; on slavery, 353-354
- Africa, the Negro in, 1-14; features of, 2; civilizations of, 2-3; slavery in, 3-4; peoples of, 5-6; empires in, 6, 7, 8-12; Negro colonists in, 269
- African colonization in the Niger Valley, 167-168
- Alabama, peonage in, 270
- Albert, A. B., an inventor, 294
- Aldridge, Ira, an actor, 148
- Alexandria, fugitive slaves in, 226
- Alien and Sedition Laws, the bearing of, on secession, 219
- Allen, Richard, founder of the A. M. E. Church, 77-78
- Alton, Illinois, the murder of Lovejoy at, 215
- American Antislavery Society, the constitution of the, 350-351
- American Federation of Labor, the, and the Negro, 334-337
- Anthony, Susan B., an abolitionist, 176
- Anti-abolition riots, 191
- Antislavery cause during the American Revolution, 66; in the South, the decline of, 86-98
- Antislavery movement restricted to the North, 187
- Antislavery argument, 52-53
- Angolas, the, 25
- Appeal, the, of a Southern Matron, 351-352
- Appleton, Nathaniel, an advocate of the rights of man, 55-56
- Apprenticeship enforced, 244
- Arkansas, the reconstruction of, 241
- Arming Negroes, the, advised, 231-232
- Artisans, Negro, 115
- Ashanti, the state of, 10
- Association for the Study of Negro Life and History, the, 341-342
- Attacks on slavery through the mails, 202
- Attacks on slavery milder, 87
- Attucks, Crispus, a martyr for freedom, 58
- Augusta, A. T., a Negro surgeon, 234
- A'Vache colony, the, 227-228
- Bacon, Thomas, interest of, in the instruction of Negroes, 39
- Baker, Henry E., opinion of, as to the Negro invention of the cotton gin, 109

- Baldwin, William H., a philanthropist, 288-289
- Ball, Thomas, a Negro contractor in Ohio, 139
- Ballou, General, a commander of Negro troops, 318
- Baltimore, Lord, the owner of Irish Nell, 47
- Baltimore, colonization in, 162, 163
- Bancroft's opinion as to the valor of Negro soldiers quoted, 65
- Banks, General, opinion of, as to Negro troops, 235
- Banks controlled by Negroes, 292
- Banneker, Benjamin, the mathematician and astronomer, 68, 69-70
- Bannister, E. M., a painter, 148, 299
- Bantu, the, 4, 15
- Baptists, the Emancipating, 56
- Barrow, David, an antislavery man in Kentucky, 90
- Bassett, E. D., a reconstruction officeholder, 252; the education of, 252
- Beard, Andrew J., an inventor, 296
- Beers, Captain, the killing of, by slaves, 36-37
- Bell, Phillip A., an editor, 148
- Benezet, Anthony, a friend of the Negro and promoter of Negro colonization, 56, 154, 155, 165
- Bentley, George, a Negro preacher, 117
- Benton, J. W., an inventor, 296
- Berea College, antislavery, 182
- Beriah Green, a teacher of Negro youth at Oneida Institute, 149
- Bias, J. G., an advocate of colonization, 166
- Biased investigators, 339-341
- Binding a State, 119-120
- Bibb, Henry, a colonizer, 166
- Birney, James G., an abolition editor, 182; press of, destroyed, 184, 192; the employment of Matilda by, 206
- Black, Jeremiah, opinion of, on granting slaves patents, 111
- Black Corsair, the, 28
- Blair, Henry, an inventor, 109
- Blazing the way on free soil, 138-152
- Blease, Cole, a leader of the poor whites, 330
- Bold slander, a, 323-325
- Booker T. Washington idea, the, 274-275
- Boston, the rising of slaves in, 36; colonization in, 161
- Bowditch, William J., an abolitionist, 174
- Bowman, Henry A., an inventor, 298
- Boyd, Henry, a successful manufacturer, 139
- Braithwaite, W. S., a literary critic, 304
- Bradley, Senator, effort of, to stop the slave trade, 81
- Brannagan, Thomas, the interest of, in colonization, 155, 165
- Brazil, the Negro Numantia in, 31-33
- Bremer, Fredrika, an abolition writer, 185
- British, the arming of Negroes by, 60-62
- British American Manual Labor Institute, the establishment of, 152
- British Guiana, sought as a place for colonization, 165
- Brown, George D., a social worker among Negroes, 286
- Brown, John, the martyrdom of, 220; the last words of, 367-368
- Brown, William Wells, a Negro historian, 146-147; an antislavery lecturer, 179
- Bruce, B. K., United States Senator, 249; education of, 251
- Bryan, Andrew, a pioneer preacher, 39, 67-68; organizer of an independent Baptist Church, 77
- Buchanan, James, a weak president, 217-218
- Bureau for the Relief of Freedmen, the, 368-369
- Burke, the imprisonment of, 188
- Burleigh, Charles C., an abolitionist, 176
- Burleigh, Harry, a musician, 298

- Burnaby, Andrew, comment of, on slavery, 35
- Burns, Anthony, the return of, 142
- Burr, the imprisonment of, 188
- Business, the progress of Negroes in, 291
- Business League, 292
- Butler, General B. F., the contrabands of, 223-224
- Cain, Richard H., a member of Congress, 249; education of, 251
- Calabar, Eboes, from, 25
- Caldwell, Elisha B., a promoter of colonization, 157, 158
- Calhoun, John C., the defense of slavery by, 197, 199-200; effort of, to have mails searched, 205, 346-348
- California, a free State, 213-214
- Canada, progress of Negroes in, 166
- Camden, Negro insurrection at, 92
- Campbell, Jabez, a churchman, 148
- Canaan Academy, the breakup of, 149
- Canada, colonization in, 167-168
- Canterbury, Ct., the Prudence Crandall affair in, 175
- Capability of Negro officeholders, 252
- Capers, Bishop, interest of, in the religious instruction of Negroes, 97
- Carnegie, Andrew, a philanthropist, 289
- Cardozo, F. L., a reconstruction officeholder, 252; the education of, 252; honorable record of, 253
- Cary, Lott, a colonizationist, 158
- Cassey, James, opposition of, to colonization, 162
- Cassey, Joseph C., a successful Negro, 135-136
- Cassor, John, a Negro owning slaves, 127
- Catto, E. V. C., a social worker, 286
- Chamberlain, quotation from, 6
- Channing, W. E., an abolitionist, 185; opinion of, on miscegenation, 187; interpretation of the constitution by, 194
- Chapman, Professor Charles E., quoted, 31
- Chapman, Maria Weston, an abolitionist, 174
- Charleston, South Carolina, refugees in, 72-73; the free Negroes of, 126-127; the prosperity of, 129
- Chase, S. P., construction of the constitution by, 194; counsel in the Van Zandt case, 206
- Chastellux, Marquis de, opinion of, as to the valor of Negro soldiers, 63-64
- Cheatham, H. P., a member of Congress, 249
- Chester, T. Morris, honorable record of, 253
- Chicago, race riot in, 328; segregation tendencies in, 333
- Child, Lydia Maria, an abolitionist, 174
- Choise, Garret, escape of, with a Negro woman, 46
- Christian slavery, 18
- Christiana tragedy, the, 141
- Churches, Negro, broken up by the Fugitive Slave Law, 141; the progress of, 284-285
- Cincinnati, the free Negroes in, 138-139, 140; riots in, 98, 140
- Cinque, Joseph, the leader of the rising on *L'Amistad*, 209
- Citizenship of Negroes, 120-121
- Civilization of Africa, 2-3
- Clark, Edward V., a successful business man, 136
- Clarkson, Thomas, a discourse on, 149
- Clay, Cassius M., an antislavery editor, 182; expulsion of, from Kentucky, 186
- Clay, Henry, interest of, in colonization, 157; the evasive position of, 198-199; the compromiser, 213
- Clergy, the attitude of, toward the blacks, 39

- Coast, Gold, the Dutch traders on, the, 21
- Codman, John, slaves of, put to death because of insurrection, 37
- Coffin, Levi, the promoter of the Underground Railroad, 143
- Collins, Henry M., a successful business man, 136; an advocate of colonization, 166
- Colonization, African, 153-168; impetus to, 154; the difficulties of, 160; protest of free Negroes against, 161-162; support of, from Negroes, 162-163; the failure of, 163-164; other schemes of, 164-168; in Canada, proposed, 165-166; in Texas, proposed, 164; in British Guiana, 164; in Santo Domingo, 164; in the West Indies, 164-165; in Trinidad, 164; revival of by Lincoln, 227; revival of, by Turner and Morgan, 268
- Colonizationists not interested in Africa, 166-167
- Columbia, the Negroes at, distributed, 141
- Columbus, segregation tendencies in, 333
- Comet, The*, freedom of slaves of, 208
- Compensated emancipation proposed, 221
- Complaint, a just, 338
- Compromise of 1850, the, 213-214
- Compromises on slavery by the Convention of 1787, 74
- Conflict of classes in cities, 332-333
- Conflict of races in cities, 333-334
- Confiscation of property, an act for, 228-230
- Congo, the, 2
- Congoes, the, 25
- Congress, the action of, on the memorial from the Quakers and from the Pennsylvania Abolition Society, 75-77; report of, adopted, 75-77; lack of interest in the Negro, 76-77
- Congress of the Confederation, silence of, on slavery, 73
- Congressional reconstruction, 246-248
- Conservatism of the Negro, 331
- Constitution of the American Antislavery Society, the, 350-351
- Constitutional questions, 236-238
- Contrabands, 223-224
- Control of white men in reconstructed States, 253
- Convention of 1787, the attitude of, toward slavery, 73-74
- Convicts as teachers of Negroes and whites, 40-41
- Cook, John F., a minister and teacher, 148
- Cook, Will Marion, a musician, 298
- Corbin, J. C., honorable record of, 253
- Cornish, Samuel E., an editor, 148
- Coromantees, 24
- Corruption explained, 254-255
- Cotter, Joseph Seaman, a writer, 303
- Cotton, the increase in the production of, 70, 83
- Cotton gin, the, invention of, 79; the effect of, 80
- Craft, William, the escape of, 141
- Craft, Ellen, a fugitive, 141
- Crandall, Prudence, the imprisonment of, 97-98, 175
- Crandall, Reuben, imprisonment of, 186
- Craney Island, fugitives in, 226
- Credit system for the freedmen, 262
- Creighton, a Negro slaveholder, 128
- Creole Case, the, 210-212
- Crime, the decrease in, 284
- Crisis of 1850, the, 213
- Crisis, The*, 277-278
- Criticism of Negroes in the army, 322
- Crittenden, Gov. John, pardon of C. Fairbank by, 188
- Croft, C., slaves of, burned alive, 37

- Cromwell, Isaac, escape of, with a white woman, 46
- Cromwell, J. W., an historian, 301
- Crothers, Samuel, an antislavery leader in the Western Reserve, 184
- Crummell, Alexander, a churchman, 148-149
- Cuffe, Paul, the interest of, in colonization, 156, 157
- Culture of Negroes, 1-14
- Curry, J. L. M., efforts of, for Negro education, 287
- Dabney, Austin, a soldier of distinction during the American Revolution, 65-66; the pension of, 66; standing of, 66
- Dahomey, the State of, 10
- Daniel, the fugitive, arrested, 141
- Dred Scott decision, 142
- Davidson, S. J., an inventor, 294
- Davis, Hugh, a white man charged with lying with a Negro woman, 47
- Davis, Joseph, attitude of, toward his slaves, 106
- Declaration of Independence, the, and the Negro, 56-57
- Decline of the Seaboard Slave States, 102
- De Grasse, John V., a Negro surgeon, 234
- Delaney, Martin R., a colonizationist, 166, 167, 168; an officer, 234
- DeLarge, R. C., a member of Congress, 249-250
- De Mello, Caetano, expedition of, sent against Palmares, 32
- Des Moines, the training camp for Negro officers at, 317-318
- De Niza, Fray Marcos, Estevanecito with, 27
- Desalines, child of the rebellion in Haiti, 72
- Dett, Nathaniel, a musician, 298
- Diaguillo, the Black Corsair, 28
- Dickinson, J. H., an inventor, 294
- Dickinson, S. L., an inventor, 294
- Dillard, J. H., efforts of, for Negro education, 287-288
- Discrimination against Negroes in the army, 315-323
- District of Columbia, emancipation in, urged, 213; slave trade in, abolished, 214
- Dix, General, attitude of, toward Negro fugitives, 224
- Donato, Martin, a Negro slaveholder, 129
- Douglas, Stephen A., popular sovereignty of, 214
- Douglass, Frederick, an opponent of colonization, 160-167, 168; an antislavery lecturer, 179-181; an officeholder, 254
- Douglass, H. F., a Negro officer, 234
- Douglass, William, a churchman, 148
- Douglass, William, an inventor, 294
- Dowd, Jerome, interest of, in the study of the Negro, 342
- Downing, Thomas, a successful Negro, 136
- Doyle, James, an inventor, 295-296
- DuBois, W. E. B., an educator and leader, 267; opposition of, to Booker T. Washington, 276-277; a controversial writer, 301
- Dubuclet, the excellent record of, 255
- Dulin, John, intelligent slave of, 44
- Dunbar, Paul Laurence, a poet, 301; works of, 301-303
- Duprey, Louis, an antislavery man, 89
- Dutch West India Company, 21
- Drake, Sir Francis, the plundering of, 21
- Drayton, D., the imprisonment of, 188
- Dred Scott case, the 216, 217
- Dresser, Amos, the punishment of, 186
- Early, of Georgia, the effort of, in favor of the slave trade, 81-82
- Eboes, 24, 25
- Economic condition of the freed-

- men, 261-263; remedies for, proposed, 263
- Economic problem of the Negro after the migration, 334
- Economic slavery after the reaction, 85, 99-123
- Education of Negroes in the Eighteenth Century, 40-42, 43, 44; prohibition of, in the South, 96; of slaves, 108-109; trial of, in solving the Negro problem, 266
- Educational advantages of Negro reconstruction officeholders, 251-252
- Efforts for economic betterment made by Negroes themselves, 337-338
- Egypt and the North, 6, 7, 8, 11
- Ellicott, George, the friend of Benjamin Banneker, 69-70
- Elliott, Robert B., a member of Congress, 251; education of, 251
- Ellis, William, a Negro surgeon, 234
- Ellsworth, Oliver, attitude of, toward slavery, 73
- Emancipation by enlistment during the Revolutionary War, 62-63; by statute, 66-67; the check of, 71; proclamation of, by Fremont during the Civil War, 228; the same by Hunter, 229; by Lincoln, 230-231, 237-238
- Emancipation Proclamation, the, the issuance of, 230-231; the constitutional aspect of, 237-238
- Emlen Institute, 139
- Encomium, The*, freedom of slaves of, 208
- Enfranchisement of Negroes, the question of, 256
- England, slavery in, 38
- Enlightenment of slaves, 108-109
- Enterprise, The*, the freedom of the slaves of, 208
- Environment, the effect of, 4-5
- Equality before the law advocated by Sumner, 356-358
- Estevanecito, explorations of, 27-28
- Ethiopia, the rise, of, 6, 7, 8
- Europe, African slaves in, 18, 19
- Evans, Henry, a preacher, 117
- Exceptional slaves, 38-39
- Explorers, Negroes with, 27-28
- Exodus of 1879, the, 263-266
- Fairbank, Calvin, the imprisonment of, 188
- Fauset, Jessie R., a writer, 303
- Featherstonaugh, comment of, on the internal slave trade, 99-100
- Fee, John G., an abolitionist, the founder of Berea College, 182
- Ferdinand, King, and the slave trade, 19
- Fessenden, W. P., reconstruction ideas of, 242
- Fighter, the Negro as, a, 325
- Finding a way of escape, 260-280
- Fifteenth Amendment, 238
- Finley, Robert, a promoter of colonization, 157
- First Regiment Infantry Corps d'Afrique, 232
- First Regiment of Louisiana Heavy Artillery, 232
- First Regiment of Louisiana Native Guards, 232
- Florida, peonage in, 270
- Follen, Eliza Lee, an abolition poet, 174
- Force bills, the enactment of, 256-258
- Force, the use of, to check the exodus of Negroes, 265
- Forten, James, an inventor, 109; a successful business man, 136; opposition of, to colonization, 162
- Fortress Monroe, fugitive slaves at, 226
- Foss, Andrew T., an abolitionist, 176-177
- Foster, Abby Kelly, an antislavery lecturer, 175-176
- Foster, Stephen, an abolitionist, 176
- Fothergill, interest of, in colonization, 154-155
- Fourteenth Amendment, 238, 244
- Francis, Henry, a teacher and minister, 68-69

- Franklin, Benjamin, interest of, in emancipation, 74-75
- Fraternal organizations, 292
- Fray, Marcos de Niza, Estevanecito with, 27
- Free Negroes, 124-137; expulsion of, from the South, 95-96; restrictions on, 95-96; the status of, 126-127; the progress of, 127; owners of slaves, 127-128; the wealth of, 128-129; relations with slaves, 133-134; a disturbing factor, 134-135; the progress of, 135; opposition of, to colonization, 160-163
- Freedmen among the Latins, 26-27; in Guatemala, 28; maltreatment of, in the South, 244
- Freedmen's Bureau, the, 245-246, 368-369
- Freedom and the Negro during the American Revolution, 58
- Fremont, John, C., the emancipatory order of, 228
- French generals, the praise of, for Negro soldiers, 321-322
- French traders of the Senegal, 21
- Fugitive, the, 112-113, 114, 142-143; reactionary measures dealing with, 202; in the army camps, 223-227; Lincoln's policy with respect to, 225; sent North, 226-227
- Fugitive Slave Law, the effect of, 141; the law of 1850, 213-214
- Fuller, Meta V. W., a sculptor, 298
- Gaboons, 24
- Gabriels Insurrection, 92
- Gag rule, the adoption of, 197-198
- Gage, Sir Thomas, quotation from, concerning the Black Corsair, 28-29; observer of exceptional slaves and Negroes, 39
- Gambia, the megaliths of, 8; English traders in, 21; Negroes from, 24
- Garnett, Henry H., a churchman and educator, 148-149
- Garrett, Thomas, an abolitionist, 174
- Garrison, William Lloyd, supposed connection with Nat Turner, 94; humiliation and imprisonment of, 191; the antislavery efforts of, 169, 170, 172; comment of, on the Constitution, 194; reward offered for, 203; extracts from *The Liberator* of, 348-350
- Gaston, William, an antislavery man in North Carolina, 88
- Gay, Sydney Howard, an abolitionist, 174
- George, James, an intelligent slave of, 44
- George III and the slave trade, 58
- Georgia, peonage in, 270
- Germans, influence of, 89; competition of, with Negro laborers, 97-98, 130
- Gerry, Elbridge, attitude of, toward slavery, 73
- Ghana, the kingdom of, 9
- Gibbs, M. W., honorable record of, 253
- Giddings, Joshua R., an antislavery congressman, 200; resolutions of, on the mutiny of the Creole slaves, 211-212; the censure of, 211; the resignation of, 211; the return of, to Congress, 212; remarks of, on slavery, 355-356, 358-359
- Godkin, E. L., comment of, on the internal slave trade, 101-102
- Goodell, William, report of, on miscegenation, 112; an abolitionist, 177
- Goodloe, Daniel R., position of with reference to teaching Negroes, 96; a southern abolitionist, 182
- Goodrich, William, a business man, 136
- Goodwyn, Morgan, appeal of, in behalf of slaves, 39
- Gordon, Robert, a successful Negro coal-dealer in Cincinnati, 139-140

- Gordon, William, interest of, in freedom, 54
- Gorsuch, the, killing of, 141
- Goybet, General, praise of, for Negro soldiers, 321-322
- Gradual emancipation becoming popular, 87-88
- Grant, U. S., attitude of, toward fugitive slaves, 224-225; the use of Negroes in the army by, 230; report of, on the South, 242-243
- Greeks and the Negro, 5, 6
- Green, Augustus R., an advocate of colonization, 166
- Green, Samuel, imprisonment of, 187
- Greene, Anna, a white woman escaping with a Negro man, 46
- Greene, Colonel, defended by Negro soldiers, 65
- Greene, General, interest of, in the enlistment and freedom of the Negroes, 61; Negro soldiers under, during the Revolutionary War, 65
- Greener, R. T., a reconstruction officeholder, 252; the education of, 252
- Greer, Allan J., an officer arrayed against Negroes, 320; letter of, to Senator McKellar, 321
- Grimké, A. H., a protagonist in the struggle for social justice, 278
- Grimké sisters, abolitionists, 177
- Guatemala, a Negro freedman in, 28; maroons in, 29-30
- Guinea, the Gulf of, 5
- Guinea Coast, slave trade on, 21
- Haiti, Negro insurrection in, 72-73; colonization in, 167, 168
- Hale, John P., an antislavery senator, 193
- Hale, Joseph, slave of, able to read and write, 42
- Hall, Basil, comment of, on the internal slave trade, 100
- Halleck, General, attitude of, toward Negro fugitives, 224
- Hamilton, Alexander, interest of, in the freedom of the Negro, 61
- Hamlet, the fugitive, arrested, 141
- Hammon, Jupiter, a writer of verse, 301
- Hampton, fugitive slaves, in, 226
- Hampton Institute, the progress of, 288-289
- Hancock, John, opposition of, to the enlistment of Negro troops, 59
- Haralson, Jere, a member of Congress, 249
- Harper, Chancellor, position of, on the teaching of Negroes, 96-97
- Harper, Frances E. W., a writer of verse, 301
- Harper, William A., a painter, 299
- Hardships of Negroes in the North, 130
- Harlan, Robert, a successful Negro in Ohio, 139
- Harris, Dr., opinion of, as to the valor of Negro soldiers in the American Revolution, 65
- Hart, A. B., quoted, 171
- Hartford, Connecticut, colonization in, 162
- Hausa, the state of, 9, 10
- Haughtiness of the aristocratic class, 255-256
- Hawkins, Sir John, exploits of, 20
- Hayes, R. B., the withdrawal of the Federal troops by, 258-259
- Haynes, George E., head of the Bureau of Negro Economics in the Department of Labor, 316
- Haynes, Lemuel, a patriot and soldier of the American Revolution, 58, 63
- Hayward, Colonel, a commander of Negro troops, 318
- Henson, Josiah, comment of, on the internal slave trade, 100-101; a promoter of the Underground Railroad, 143; the prototype of *Uncle Tom's Cabin*, 151-152

- Henry, Patrick, an advocate of freedom, 57
- Hermosa, The*, freedom of the slaves of, 208
- Higher pursuits, slaves in, 44-45
- Higginson, T. W., a leader of Negro troops, 235
- Hill, of Chillicothe, a successful Negro, 138
- Hill, L. P., a writer, 303
- Hillsboro, Negro insurrection at, 92
- Hilyer, A. F., an inventor, 294
- Hispaniola, slave traders, 20
- Hoffman, Frederick L., interest of, in the study of the Negro, 342
- Hollie, Sallie, an abolitionist, 177
- Holly, J. T., a colonizationist, 166, 167, 168; in Haiti, 168
- Homes of Negroes, improvements in, 287
- Hooter, H. E., an inventor, 296
- Hopkins, Samuel, interest of, in freedom, 54
- Hovey, Charles F., an abolition merchant, 174
- Howard, O. O., head of the Freedmen's Bureau, 245-246; founder of Howard University, 246, 288
- Howard University, the establishment of, 246
- Howells, W. D., a friend of Dunbar, 301
- Hunter, Alexander, the purchase of a slave by, 127
- Hunter, Major General, the emancipatory order of, 229; Negroes armed by, 232
- Humphries, Solomon, a wealthy Negro, 129
- Hunton, William A., first Negro International Young Men's Christian Association Secretary, 286
- Hyman, John A., a member of Congress, 249
- Impending Crisis, The*, 216-217
- Indianapolis, segregation tendencies in, 333
- Industrial revolution and the reaction, 79-80
- Industrial Schools, Negro, the progress of, 288-289
- Inferiority of races, question of, 339-341
- Institutions of learning founded, 266
- Insurance companies controlled by Negroes, 292
- Insult to Negro army officers, 322-323
- Insurrection of the Negroes during the early periods in the colonies, 36-37; in the West Indies, 72-73; in the United States, 92-94
- Intellectual development, 41-42, 43-44
- Interbreeding, 133
- Interest, differing, of the sections, 118-119
- Internal improvements, the question of, 123
- Internal slave trade, 99-102
- International entanglements, 208-212
- Interstate slave trade, 104; the regulation of, 103
- Intimidation of Negroes in the South, 244
- Inventions of Negroes, 109, 110, 111, 293; the difficulties of, 298
- Investigation of social problems a necessity, 341
- Investigators, biased, 339-340
- Irish Nell, marriage of, to a Negro slave, 47
- Irish in the North, competition of, with Negro laborers, 97-98, 130
- Irrepressible Conflict, The*, of William H. Seward, 363-365
- Isabella, Queen, attitude of, toward slavery, 19
- Jackson, Benjamin F., an inventor, 294
- Jackson, Francis, an abolitionist, 174
- Jackson, May Howard, a sculptor, 299

- Jacobs, Governor R. T., pardon of Fairbanks, by, 88
- Jamaica, Francis Williams, the scholar, in, 29; agents from, in quest of Negro immigrants, 164-165
- James, David, an illegitimate mulatto bound out, 48
- Jameson, J. F., interest of, in the study of the Negro, 342
- Jay, William, the enemy of colonization, 96-97; thought of, on miscegenation, 187; opinion of, as to the Constitution, 194
- Jefferson, Thomas, an opponent of slavery, 57-58; message to Congress concerning, 81; his fear of the evil, 90; interest of, in colonization, 155; correspondence of, with Banneker, 70
- Jenkins, David, a successful Negro in Ohio, 138
- Jenne, the state of, 10
- Jerry, the fugitive arrested in Syracuse, 141
- Johnson, Andrew, acceptance of Lincoln's reconstruction plan by, 241-242
- Johnson, Georgia Douglas, a poet, 303
- Johnson, James Weldon, a writer, 303
- Johnson, Oliver, an abolitionist, 177
- Johnson, William H., an inventor, 296
- Johnson, a hero of the World War, 325
- Johnson, General, the attitude of, toward fugitive slaves, 224
- Jones, C. C., interest of, in the instruction of Negroes, 97
- Judson, Andrew T., the decision of, in the *Amistad Case*, 209
- Kansas-Nebraska question, 214
- Kansas Colored Volunteers, 232
- Keith, George, interest of, in the instruction of Negroes, 39; in colonization, 154
- Kemble, Frances, an antislavery writer, 185
- Kench, Thomas, interest of, in the enlistment of Negroes, 63
- Kentucky, failure of, to prohibit the teaching of Negroes, 96
- Key, Francis Scott, a promoter of colonization, 157
- Koch, Bernard, the agent of the colonizationists of the Civil War period, 227-228; governor of the A'Vache colony, 227-228
- Kreamer, Henry, an inventor, 294
- Ku Klux Klan, the operations of, 256-258, 269; recrudescence of, 325-326
- Labor a factor in the Negro situation, 306-307
- Loyalty of Negroes, 313, 314, 316-317
- Lafayette, Marquis de, opinion of as to the valor of Negro soldiers, 65
- Lafon, Thomy, a wealthy Negro, 127
- Lago, William, the indictment of, in Kentucky, 203
- Lambert, William, a colonizationist, 166
- L'Amistad*, the freedom of the slaves of, 209
- Lane, Lunsford, an antislavery lecturer, 176, 179
- Lane Theological Seminary, antislavery, 184
- Langston, J. M., a member of Congress, 249; the education of, 251
- Latimer Case, the, 206-207
- Last words of John Brown, 367-368
- Latins, the enlightenment of slaves among, 26
- Latrobe, J. H. B., a factor in colonization, 159
- Laurens, Henry, the proposal of, for enlisting and freeing Negroes, 58, 62
- Law, Josiah, interest of, in the instruction of Negroes, 97
- Lawrence, Samuel, rescue of, by Negroes, 58

- Lay, Benjamin, attack of, on slavery, 53-54
- Leadership, trained, 290
- Leavitt, Joshua, an abolitionist, 171
- Lecky's opinion of the valor of Negro soldiers mentioned, 65
- Lecturers, antislavery, 175-177
- Lee, Joseph, an inventor, 296
- Le Jeune, Paul, a missionary, 39
- Leonard, James, an intelligent slave of, 44
- Le Petit, a missionary, 39
- Lewis, Edmonia, the artist, 148
- Lewis, John W., a Negro business man, 292
- Liberator, The*, the influence of, 170, 171; beginnings of the, 348-350
- Liberia, the exodus of Negroes to, 128
- Liele, George, a pioneer preacher, 68
- Lincoln, Abraham, the slavery issue by, 215, 216, 221, 228; interest of in compensated emancipation, 221; policy of, in dealing with fugitive slaves, 225; interest of, in freedmen, 227, 240; emancipation by, 229-230; powers of, 238-239; plan of, for reconstruction, 239-240; comment of, on lynching, 370-371
- Long, Jefferson F., a member of Congress, 249
- Longfellow, H. W., antislavery writings of, 185
- Louisiana, reconstruction of, 241
- Louisiana Purchase, the, and slavery, 78-79
- L'Ouverture, Toussaint, leader of the insurrection in Haiti, 72
- Lovejoy, Elijah P., the murder of, 192, 215
- Lowden, Fred J., an inventor, 296
- Lowell, J. R., the antislavery writings of, 185
- Lundy, Benjamin, an abolitionist, 182
- Lundy, Benjamin, a gradual emancipationist, 89; a colonizationist, 156
- Lynch, John R., a member of Congress, 249; the education of, 251
- Lynching on the increase, 261; in Washington, 327-328; remarks of Lincoln on, 369, 371
- McCook, General, attitude of, toward the fugitive slaves, 224
- McCoy, Elijah J., an inventor, 297
- McCrummell, James, the opposition to colonization, 162
- McHenry, James, a friend of Benjamin Banneker, 70
- McKellar, Senator K. D., the letter of Allan J. Greer to, 320
- McKim, an agent of the Underground Railroad, 177
- Madison, James, suggestion as to emancipation, 62
- Madison, James, the complaint of the sister of, as to miscegenation, 111-112
- Madison, W. G., an inventor, 296
- Mahan, Asa, an antislavery student at Lane Seminary, 184; one of the founders of Oberlin College, 184; indictment of, in Kentucky, 203
- Mail, the use of, in reaching Negroes, 203
- Major, John, the murder of, by slaves, 36
- Mansfield, Lord, the Somerset decision of, 38
- Manumission after the French and Indian War, 54-55; in the Middle States, 54, 55
- March, Charles, a colonizationist, 157
- Marcy, Governor, attitude of, toward the fugitive, 203
- Maroons, the, 30-31; in Guatemala, 29-30
- Martin, Samuel, a Negro slaveholder, 128
- Martin, Asa, estimate of the extent of the internal slave trade by, 102
- Martineau, Harriet, a case of miscegenation observed by, 112

- Maryland, failure of, to prohibit the teaching of Negroes, 96
- Maryland, miscegenation in, 46-47; free Negroes sold in, 130
- Maryville College, antislavery, 182
- Mason, George, an advocate of freedom, 58
- Massachusetts, Negroes of, leave for Canada, 141; the uprising of slaves in, 36; protest of, against the enlistment of Negroes in the American Revolution, 58
- Massacres of Negroes, 261
- Matilda, the question as to the freedom of, 206
- Matthews, W. D., a Negro officer, 234
- Matzelliger, Jan E., a noted Negro inventor, 293; results from patent of, 293-294
- May, Thomas, an intelligent slave of, 42
- May, Samuel, Jr., an abolitionist, 174
- May, Samuel J., an abolitionist, 174, 175
- Measurements, psychological, 340-341
- Mechanics, Negro, 115
- Mecklin, John M., interest of, in the study of the Negro, 342
- Mediterranean world, Negroes in, 6, 7, 8
- Melle, the kingdom of, 9-10
- Memphis, fugitive slaves in, 226
- Menial service of Negroes in the North, 274
- Mendez, exploits of, 21
- Mercer County, Ohio, the Negroes in, 139
- Mercer, Charles Fenton, interest of, in colonization, 157
- Merrick, John, a business man, 292
- Methodists, opposition of, to slavery, 56
- Metoyer, Marie, a negro slaveholder, 129
- Mexico, the organization of territory acquired from, 213; Negro colonists in, 269
- Middle States, slavery in, 35-36; Manumission in, 54
- Miflin, Ann, interest of, in colonization, 155-156
- Migration of the Negroes to the North, 265-266, 306-310; causes of, 309-310
- Military districts in the South, 247
- Mild attack on slavery, 87
- Miller, Kelly, an educator, 267, 301
- Miller, Matthew, opinion of, as to Negro troops, 236
- Miller, Thomas E., a member of Congress, 251
- Milligan Case, the, 236
- Mills, Elijah J., a promoter of colonization, 157
- Mills, Samuel J., a colonizationist, 157
- Miner, Myrtila, the work of, 144
- Minor, Patrick A., a Negro officer, 234
- Miscegenation of the whites and blacks, 45-50, 133; danger of, 50; cases of, 111-112
- Mississippi, peonage in, 270
- Missouri Compromise, 120-121; comment on, by J. Q. Adams, 343-344; remarks of John Sergeant on, 344-346
- Mobile, Alabama, the Negroes of, protected by the Louisiana Purchase Treaty, 78-79
- Mohammed Askia, 11
- Mohammedans in Africa, 8, 9, 10, 11, 12, 15, 16, 17
- Molson, Richard, the escape of the slave of, with a white woman, 46
- Montgomery, Benjamin T., an inventor, 111
- Montgomery, Isaiah T., experiences of, as a slave, 106; a business man, 292
- Monroe, President, interest of, in colonization, 159
- Moore, William, intelligent slave of, 42
- Morgan, John, an antislavery student at Lane Seminary,

- 184; one of the founders of Oberlin College, 184
- Morgan, Senator, interest of, in colonization, 268-269
- Morris, Thomas, an antislavery congressman, 193
- Moton, R. R., the head of Tuskegee, 291
- Mott, Lucretia, an abolitionist, 177
- Mott, James, an abolitionist, 177
- Mound Bayou, the home of a former slave, 106
- Mulattoes, 133
- Mulber, Luke, a successful Negro in Ohio, 138
- Murray, George W., a member of Congress, 251; an inventor, 294
- Mustees, 133
- Nagoes, 24
- Nash, Charles E., a member of Congress, 249
- National Association for the Advancement of Colored People, the work of the, 277-278
- National Association of Funeral Directors, 292
- National Negro Bankers' Association, 292
- National Negro Retail Merchants' Association, 292
- Negro, the, enslaved, 15-34; the rights of man and the, 51-52; status of, reduced, 86, 87; in the Civil War, 221-238; in the World War, 305-328; the, and social justice, 328-342
- Negro contrabands, the record of, 230
- Negro Churches, 117
- Negro preachers, 117
- Negro soldiers, enlisted in Virginia, 61; in Rhode Island, 62-63; in New York, 63; in New Hampshire, 63; in Maryland, 63; opinions as to service of, 63-65
- Negro units proposed for the American Revolutionary forces, 58-59; protest against, 58-59; decision against, 59; fear of, 60-61; armed by British, 60-62
- Negroes as refugees during the Civil War, 223-230; loyal to the United States, 313-314
- Nell, Irish, marriage of, to a slave, 47
- Nell, William C., a Negro historian, 145-146
- Newberne, Negro insurrection at, 92-93
- New England, slavery in, 35
- New England and secession, 219
- New Orleans, Haitian refugees in, 72-73
- New York City, the Negro riot in, 37, 98; miscegenation in, 49; colonization in, 161, 162, 163; antislavery society in, 171-172; anti-abolition movement in, 191; the fugitive question in, 203
- New York Fifteenth, 318
- Niger, the, 2, 8; Martin R. Delaney in the valley of, 167-168
- Nile, the, 2, 6, 7
- Niles, Hezekiah, a promoter of colonization, 157
- Niles, Nathaniel, interest of, in freedom, 54
- Ninety-second Division, of Negro soldiers, 318
- Norfolk, Haitian refugees at, 72
- North, reaction against the Negro in, 76-77; the free Negroes in, 129-137; fugitives in, 226-227; the migration of Negroes to, 271-272, 306-310; the advantages of Negroes in, 307, 308; troubles of Negroes in, 310-311; the recent situation in, 331
- North Carolina, miscegenation in, 48-49; Negro voters in, 67; peonage in, 270
- Numantia, the Negro, 31-33
- Oberlin College, the establishment of, 184
- Officers, Negro, the demand for, 316-317; discrimination against, 317-325; training of, at Des Moines, 317-318; praised by French, 321-322

- Ogden, Robert C., a philanthropist, 289
- O'Hara, James E., a member of Congress, 249; the education of, 251
- Ohio, the question of fugitives in, 203; anti-Negro laws of, 206
- Opposition to slavery, 216-217
- Oppression a cause of migration, 310
- Ordinance of 1787, the emancipatory clause of, 66, 73, 120
- Ordingsell, Anthony, the sale of a slave by, 127
- Otis, James, an advocate of freedom, 57
- Outcast, the free Negro an, 132-133
- Paine, L. W., the imprisonment of, 188
- Palmares, the Negro Numantia, 31-33; the destruction of, 33
- Palmyra, riot at, 98
- Parker, John T., an inventor, 296
- Pawpaws, 24
- Paxton, John D., the attack of, on slavery, 90
- Payne, Daniel A., a churchman, 148
- Pelham, Robert A., an inventor, 294
- Penn, William, the owner of slaves, 35
- Pennington, J. W. C., a churchman, 149-150
- Pennsylvania, miscegenation in, 49-50; anti-abolition riots in, 191-192
- Pennsylvania Society for the Abolition of Slavery, memorial of, to Congress, 75; action taken thereon, 75-77
- Peonage, 270-271
- Pernambuco and Palmares, 31-33
- Perry, Heman, a business man, 292
- Personal liberty laws, 112-113, 205-206
- Phelps, J. W., the arming of Negroes, undertaken by, 232
- Philadelphia, miscegenation in, 49; manumission promoted in, 54; riot in, 98; progress of free Negroes in, 136; segregation tendencies in, 333
- Philanthropist, The*, 184
- Phillips, Wendell, an antislavery orator, 172, 174; attitude of, toward the Constitution, 216
- Physicians, Negro, 285
- Pickens, William, an orator, 267, 301
- Pickering, J. L., an inventor, 296
- Pinchback, P. B. S., a reconstruction officeholder, 252; the education of, 252; record of, 254
- Piracy, 21
- Pittsburg, riot in, 98; segregation tendencies in, 333
- Plantation system as a result from the industrial revolution, 79-80, 105, 106, 107
- Platt, William, a successful free Negro, 135
- Politics and slavery in the South, 83
- Politicians, Negro, leaving the South, 272
- Polk, Bishop, interest of, in the instruction of Negroes, 97
- Popular sovereignty, 214
- Portsmouth, Ohio, riot at, 98, 140; fugitive slaves in, 226
- Port Royal, South Carolina, fugitive slaves in, 226
- Portugal, slaves in, 1
- Poore, Salem, exploits of, 58
- Potomac, the bravery of Negroes along, 236
- Powell, William, a Negro surgeon, 234
- Prejudice a factor in the South, 254; in the army, 323
- Preparation of slaves for emancipation, 67-68
- Presbyterians, opposition of, to slavery, 56
- Presley, J., a successful Negro in Ohio, 139
- Price, J. C., an orator and educator, 266
- Prigg Case, the, 206

- Prince Henry, explorations of, 19
Privileges of free Negroes, 131-132
Professions, Negroes in, 283-284
Progress of the Negro race, statistics on, 280-283; of the Church, 284-285
Promoters of colonization, 154-155
Property of Negroes, the worth of, 292
Proslavery argument, 52-53
Proslavery victory in the mild prohibition of the slave trade, 82
Protest, further, 182-194
Proverbs, African, 12-14
Punishment of slaves, 108
Puritans, attitude of, toward slavery, 52
Pursuits, higher, slaves in, 44-45
Purvis, Robert, opposition of, to colonization, 162
Purvis, Charles B., a Negro surgeon, 234
Purvis, W. B., an inventor, 294
- Quakers, attitude of, toward slavery, 52, 54; memorial of, to Congress, 74, 75, 76; opposition of, to slavery continued, 88; interest of, in colonization, 154-155
Quincy, Edmund, an abolitionist, 174
Quinn, William P., a minister, 148
- Races in Africa, 1-14
Race riot in Washington, 326-328
Radical leaders of poor whites, 330
Rainey, J. H., a member of Congress, 249
Randolph, John, the attitude of, toward the slave trade, 82; comment of, on slavery, 90; on colonization, 157
Rankin, John, an antislavery leader in the Western Reserve, 184; comment of, on miscegenation, 187
- Ransier, Alonzo J., a member of Congress, 251
Rapier, James T., a member of Congress, 249; the education of, 251
Rapier, John, a Negro surgeon, 234
Rappahannock River, the rising of slaves on, 36
Ray, Charles B., a churchman, 148; letter of, Gerrit Smith to, 186
Ray, Robert, opposition of, to colonization, 162
Raymond, Daniel, the opposition of, to slavery, 90
Reaction against the Negro, 71-85; in the North, 97-98
Reason, Charles L., a scholar, 148
Rebellion of the Negroes in the West Indies, 72-73
Reconstruction of the Southern States, 239-259; various theories about, 242; the plan of Congress for, 246-248; the undoing of, 259
Redpath, James, a colonizationist, 168
Reed, William N., a Negro officer, 233-234
Refugees, Haitian, in United States, 72-73; influence of, 92-93
Religious bodies opposed to slavery, 51-52
Religious freedom, the bearing of, on the emancipation of the Negroes, 67-68
Removal of a slave to a free State, the effect of, 205; in Pennsylvania, 205; in Massachusetts, 205
Remond, Charles Lenox, an antislavery lecturer, 178-179, 180
Rent system for the freedmen, 262
Republican Party, the organization of, 217
Relations of slaves and free Negroes, 133-134
Religious instruction limited, 116-118

- Restored South, 268; the cruelty of, 268
- Resignation of Negroes to fate, 267
- Restrictions on manumissions, 128; on free Negroes, 130-131
- Return of Negroes to the South, 130
- Return of fugitives, the constitutional question of, 200-202
- Revels, Hiram R., a member of the United States Senate, 249; the education of, 251
- Rhett, of South Carolina, in the defense of slavery, 198
- Ricard, Cyprian, a wealthy Negro, 129
- Richardson, Richard, the sale of a slave by, 127
- Richards, Benjamin, a business man, 136
- Richey, Charles V., an inventor, 294
- Riddell, W. R., interest of, in the study of the Negro, 342
- Right of petition denied, 195-198
- Rights of man and the Negro, 55-56
- Rillieux, Norbert, an inventor, 109-110
- Riots of Negroes with Irish and Germans in the North, 98, 140-141
- Rise, the, of the poor whites, 330
- Roberts, a hero of the World War, 325
- Robinson, E. A., an inventor, 298
- Rockefeller, John D., a philanthropist, 298
- Rockefeller, John D., Jr., interest of, in the study of the Negro, 342
- Rogers, H. H., a philanthropist, 289
- Rogers, N. P., an abolitionist, 177
- Roques, Charles, a Negro slaveholder, 129
- Rosenwald, Julius, a philanthropist, 289; interest of, in the study of the Negro, 342
- Royal African Company, 21
- Ruffner, effort of, for Negro educator, 288
- Ruggles, David, a leader in the crisis, 149
- Rush of Negroes to cities, the, 272, 273
- Russwurm, John B., the first Negro college graduate in the United States, 144-145; a colonizationist, 159, 160
- Rutherford, S. W., a Negro business man, 292
- Rutledge, Governor, a Negro slave of, distinguished by his valor, 65
- Salem, Peter, the killing of Major Pitcairn by, 58
- Sandiford, Ralph, attack of, on slavery, 53
- Sandoval, Alphonso, protest of, 39
- Sandy Lake, the settlement of, broken up, 141
- Santo Domingo, Negro insurrection in, 72; sought as a place for colonization, 165
- Savannah, Georgia, the uprising of slaves at, 36
- Schools, Negro, the progress of, 288-289
- Schurz, Carl, report of, on the South, 242-243
- Scotch-Irish, influence of, 89
- Scott, Emmett J., Special Assistant to the Secretary of War, 316, 318
- Scott, George, the self-assertion of the slaves of, 36
- Scott, Henry, a successful Negro, 135-136
- Scott, William E., a painter, 299
- Seamen Acts of South Carolina, 202
- Searching the mails, 205
- Secession undertaken, 217, 218, 219-220
- Secret Information concerning Black American Troops, 323-324
- Senegal, traders on, 21; colonization on the, 159
- Segregation, the results of, 338

- Sergeant, John, remarks of, on the Missouri Compromise, 344-346
- Servants indentured, 17, 18
- Service of Negro troops, 234-236
- Settlements of Negroes broken up, 140-141
- Sevilla, slaves in, 19
- Seward, W. H., attitude of, toward the fugitive, 202; an antislavery leader in Congress, 216; counsel in the John Van Zandt case, 206; *Higher Law than the Constitution* of, 359-361; *Irrepressible Conflict* of, 363-365
- Shadrach, the fugitive, arrested, 141
- Sharp, Granville, attorney in the Somerset case, 38; interest of, in colonization, 155
- Shaw, John, refusal of, to grant a writ for the freedom of a fugitive, 206
- Shaw, R. G., a commander of Negro troops, 235
- Shellabarger, reconstruction plan of, 242
- Sherbro, the figures of, 8, 9
- Singleton, Benjamin, a leader of Negro migrants, 264
- Simms, Thomas, the fugitive arrested, 142
- Simpson, William H., a painter, 148
- Skilled labor, 281-282
- Slade, William, an antislavery congressman, 193
- Slander, a bold, 323-325
- Slavebreeding, 102
- Slave trade, 16, 17; the horrors of, 22, 24; in the South, 72; efforts to stop the, 80-82
- Slave trading corporations, 21
- Slavery, ancient, 15; Mohammedan, 15, 16, 17; Christian, 18; European, 18, 19; the introduction of, in America, 21; in its mild form, 34-50; slavery in the North, 35; in New England, 35; in the Middle States, 35-36; slavery in England, 38; in the eighteenth century, 40; early objections to, 51-52; as affected by the Louisiana Purchase Treaty, 78-79; the effect of, on the South, 117-118; with respect to the tariff, 121-122; attacked as an evil, 170; with respect to the Constitution, 195; in politics, 217; the defense of, by J. C. Calhoun, 346-348; the comment of J. Q. Adams on, 353-354; remarks of J. R. Giddings on, 355-356, 358-359; comment of A. Lincoln on, 361-362; remarks of B. F. Wade on, 365-367
- Slavers, 22
- Slaves, brought to the West Indies, 23; source of, 24-25; hardships of, 25-26; the enlightenment of, among the Latins, 26; able to read and write, 42-43; well-dressed, 43; slaves in good circumstances, 44; slaves in higher pursuits, 44-45; relation with poor whites, 45-46; sold South, 103-104, 105; control of, 106; the care of, 107; the punishment of, 108; in towns, 114-115; relations of, with free Negroes, 133-134
- Smalls, Robert, a member of Congress, 251
- Smart, Brinay, an inventor, 296
- Smilie, of Pennsylvania, the effort of, against the slave trade, 81
- Smith, Gerrit, the antislavery efforts of, 185-186
- Smith, James, an inventor, 296
- Smith, James McCune, a Negro physician in New York, 145; letter of G. Smith to, 186
- Smith, R. L., a business man, 292
- Smith, Stephen, a lumber merchant, 136
- Social relations of Negroes and whites, 111, 116
- Society for the Propagation of the Gospel in Foreign Parts, 39
- Soldiers, Negro, in the World

- War, 314-325; restriction of, in the service, 314-315; assignment of, to labor divisions, 315-316; the abuse of, 315-316; the record of, 325
- Somerset decision, 38
- Songhay, the empire, of 11-12
- Soni Ali, 11
- South, the situation in, after the reaction, 84-85; affected by slavery, 117-119; the last stand of, 217-218; under martial law, 247; the exodus of Negroes from, a calamity, 312-313; radical reaction in, after the World War, 339
- South Carolina, the reopening of the slave trade by, 80-81; secession of, 217; peonage in, 270
- Southern matron, the appeal of a, 351-352
- Southern States, the adoption of different plans by, 247-248
- Spain, African slaves in, 18, 19
- Spingarn, J. E., a friend of the oppressed, 278
- State, limitations on a, 119-120
- Statistics on free Negroes, 124-126; on the progress of, 138-140, 281-283; on the Negro Church, 284-285
- Stebbins, Charles B., an abolitionist, 177
- Stiles, Ezra, interest of, in freedom, 54
- Still, William, an agent of the Underground Railroad, 143
- Stone, Daniel, an opponent of slavery, 215
- Stone, Lucy, an abolitionist, 176
- Storey, Moorfield, a friend of the oppressed, 278
- Stowe, Harriet Beecher, the writings of, 152
- Stringent measures in the South, 94-95
- Study of the Negro, the, undertaken, 341-342
- Sudan, the empires of, 7
- Suffolk, fugitive slaves in, 226
- Sugar industry and slavery, 84
- Sumner, Charles, opinion of, on the mutiny of the Creole slaves, 210; reconstruction ideas of, 242; interest of, in the freedmen, 245; on equality before the law, 356-358
- Suttle, Charles F., claimant of Anthony Burns, 142
- Talmadge, James, effort of, to prevent slavery in Missouri, 118
- Tanner, H. O., a renowned painter, 299-300; paintings of, 299-300; prizes of, 299-300
- Tappan, Arthur, an abolitionist, 185; a reward offered for, 203
- Tappan, Lewis, an abolitionist, 171, 185
- Tariff and slavery, 121-122; opposition to the tariff, 122
- Tarboro, Negro insurrection at, 92
- Taxation during the Civil War, 237
- Tennessee, failure of, to prohibit the teaching of Negroes, 96
- Tennessee, the reconstruction of, 241
- Ten per cent governments, 240
- Terrell, Frank J., an inventor, 294
- Terrorism in the South, 269
- Texas, slavery and, 200; sought as a place for colonization, 165; the claims of, 213
- Thirteenth Amendment, 238, 241
- Thompson, A. V., a successful Negro in Ohio, 139
- Thompson, George, lecture of, stopped by mob, 191
- Thompson, the imprisonment of, 188
- Tillman, Benjamin, a leader of the poor whites, 330
- Tilghman, Richard, the escape of the slave of, with a white woman, 46
- Timbuctu, the city of, 10
- Toleration and the Negro, 55
- Topp, Henry, a successful Negro, 135
- Torrey, C. T., imprisonment of, 188

- Town slaves, 114-115
 Traders, slave, 19-20
 Trades unions and the Negro, 273, 334-337
 Trinidad, colonization in, 164-165
 Troops, Federal, in the South, 258; the withdrawal of, 258-259
 Troops, Negro, the use of, 233-234; the status of, 234; the record of, 234-236
 Trotter, W. M., a leader opposed to Booker T. Washington's policies, 277; the humiliation of, 277
 Truth, Sojourner, an antislavery lecturer, 179
 Tubman, Harriett, the career of, 115; a promoter of the Underground Railroad, 143
 Tucker, Alpheus, a Negro surgeon, 234
 Tupes, Colonel, praise of, for Negro soldiers, 321-322
 Turner, Benjamin, a member of Congress, 249; education of, 251
 Turner, Franklin, an advocate of colonization, 166
 Turner, Bishop H. M., interest of, in colonization, 268-269
 Turner, Nat, insurrection of, 93-94
 Tuscaloosa County, the indictment of R. G. Williams by, 203
 Tuskegee, the progress of, 288-289
 Tyler, Ralph, a war correspondent, 320
Uncle Tom's Cabin, 152, 217
 Underground Railroad, 113-114, 142-143, 152
 Union, the nature of, 122, 218-219; the cause of, at first a failure, 156
 Union Humane Society, 156
 Usher, Roland G., interest of, in the study of the Negro, 342
 Unskilled labor, 281
 Untoward condition of the freedmen, 260-261; economic situation, 261-262
 Unwilling South, the, 242-243
 Vagrancy laws of the South, 244
 Valladolid, Juan de, 19
 Van Zandt, John, the fine of, 206
 Van Buren, attitude of, in the *L'Amistad* case, 210
 Vardaman, J. K., a leader of the poor whites, 330
 Varick, James, founder of the A. M. E. Zion Church, 77-78
 Varnum, General, enlistment of Negroes by, 62-63
 Vasa, Gustavus, 13
 Vashon, George B., a lawyer, 148
 Vermont, the fugitive in, 206
 Vesey, Denmark, leader of an insurrection, 93
 Vicksburg, meeting at, to check the exodus of 1879, 264
 Villard, O. G., grandson of William Lloyd Garrison, 278; interest of, in the study of the Negro, 342
 Virginia and Kentucky Resolutions, the bearing of, on secession, 219
 Virginia, miscegenation in, 47-48
 Wade, Benjamin F., the defiant unionist, 219; attack of, on slavery, 365-367
 Wage system for the freedmen, 262
 Wainrite, Anne, escape of, with a negro woman, 46
 Walker, Madame C. J., a business woman, 292
 Walker, David, appeal of, 93, 95; connection of, with the Nat Turner insurrection questioned, 94
 Walker, John, suffering of, 188
 Wall, O. S. B., a Negro officer, 234
 Walls, Josiah T., a member of Congress, 249
 Ward, Joseph, the opposition of, to the enlistment of Negro troops, 59

- Ward, S. R., a minister and orator of power, 149, 151
- Washington, Booker T., the policy of, 274; the Atlanta address of, 274-275; ideas of, accepted, 275; opposition to, 276; the results of the work of, 279; a writer, 301
- Washington, Bushrod, a promoter of colonization, 158
- Washington, George, order of, to stop the enlistment of Negro troops, 59; revocation of the order, 61; the enlistment of Negroes by, 61; interest of, in emancipation, 58
- Washington, fugitive slaves in, 226; race riot in, 326-327; a lynching, 327-328
- Watrum, F. P., a missionary, 39
- Wayman, Alexander W., a churchman, 148
- Webb, William, an advocate of colonization but not of African deportation, 166
- Webster, Delia, the imprisonment of, 188
- Webster, Daniel, the evasive position of, 198-199; opinion of, on the Creole slaves, 210
- Webster, Samuel, interest of, in freedom, 54
- Weld, T. F., an antislavery student at Lane Seminary, 184; an abolitionist, 177
- Wesley, Charles H., interest of, in the study of the Negro, 342
- Wesley, John, opposition of, to slavery, 56
- West Indies, slaves carried to, 23; the lot of slaves in, 25, 26
- Wheatley, Phyllis, a writer of verse, 68, 301
- Wheeler, John H., the escape of the slave of, 205
- Whipper, William, the agent of the Underground Railroad, 143
- White, George H., a member of Congress, 249
- White, J. T., honorable record of, 253
- Whitfield, James M., a writer of verse, 148; an advocate of colonization, 166, 167
- Whittier, John G., the antislavery writings of, 185
- Whydahs, 24
- Wilberforce, the antislavery efforts of, 165
- Wilcox, Samuel T., a Negro grocer in Cincinnati, 139
- Williams, Francis, the scholar, 29-30
- Williams, G. W., an historian, 301
- Williams, John, intelligent slave of, 42
- Williams, Peter, a churchman, 148
- Williams, Roger, protest of, against slavery, 52
- Williams, R. G., the indictment of, in Alabama, 203
- Williamsburg, Virginia, an insurrection of slaves in, 36
- Williamson, Passmore, efforts of, to obtain the freedom of Jane Johnson, 205
- Willis, Joseph, organizer of Baptist churches in Mississippi, 77
- Wilmot Proviso, the, 212
- Wilson, Henry, reconstruction ideas of, 242
- Wilson, Hiram, a worker among Canadian Negroes, 152
- Winslow, Sydney W., the purchaser of Matzeliger's patent, 293
- Wise, Henry A., the defense of slavery by, 196-197
- Woods, Granville T., an inventor, 296-297
- Woods, Lyates, an inventor, 297
- Woodson, C. G., founder of the Association for the Study of Negro Life and History, 341
- Woolman, John, a Friend pleading the cause of the Negro, 56
- Work, F. W., a musician, 298-299
- Work, J. W., a musician, 298
- World War, the Negro soldiers in, 305-328
- Wright, Elizur, an abolitionist, 171; an instructor, 184

- Wright, Henry C., an abolitionist, 177
- Wright, Theodore S., letter of Gerrit Smith to, 186
- Wythe, George, an advocate of freedom, 58
- Yorktown, fugitive slaves in, 226
- Young, Colonel Charles, the proscriptioin of, 317-318
- Young Men's Christian Association, the work of, among Negroes, 286-287
- Young Women's Christian Association, the work of, among Negroes, 287
- Zambezi, the, 2

213





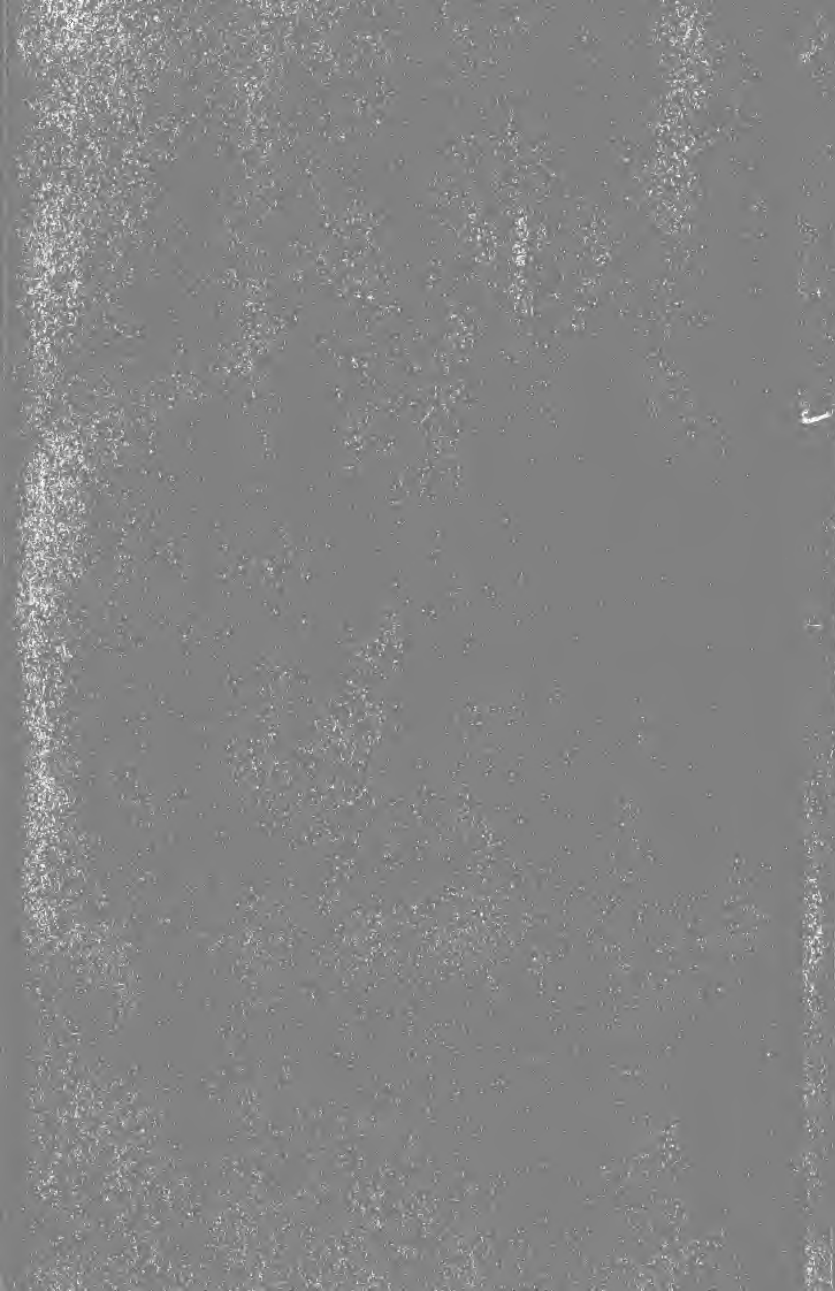

**RETURN
TO** →

MAIN CIRCULATION

ALL BOOKS ARE SUBJECT TO RECALL
RENEW BOOKS BY CALLING 642-3405

DUE AS STAMPED BELOW

FEB 03 1995

FEB 28 1997

APR 07 1997

MAR 17 2002

SENT ON ILL

JAN 02 2003

U. C. BERKELEY

UNIVERSITY OF CALIFORNIA, BERKELEY
BERKELEY, CA 94720

FORM NO. DD6

EDUC. PSYCH. LIBRARY

AUT

YB 20436

U. C. BERKELEY LIBRARIES



C042551757

486514

E
185
W9

THE UNIVERSITY OF CALIFORNIA LIBRARY

