

THE NEW YORK TRADE SCHOOLS
TEXT BOOK ON PATTERN DRAFTING



Class TS 250

Book 1 N 7

Copyright N^o _____

COPYRIGHT DEPOSIT.

THE
New York Trade School's Textbook
ON
Pattern Drafting

SUITABLE FOR ALL WORKERS IN SHEET METAL.

*This Treatise represents the Course of Instruction provided by the
New York Trade School in its Sheet Metal Department*

DRAWINGS AND TEXT PREPARED BY
WILLIAM NEUBECKER, INSTRUCTOR

FIRST EDITION

COPYRIGHTED, 1905, BY
NEW YORK TRADE SCHOOL

T 31200
.NS

LIBRARY of CONGRESS
Two Copies Received
NOV 24 1905
Copyright Entry
200 24 1905
CLASS Cl Xxc. No.
131901
COPY B.

31

5-40298

PREFACE

In addition to the practical construction of metal cornices and skylights, and the preparation of patterns bearing on those branches, the Course of Instruction in the Sheet Metal Department of the New York Trade School is now enlarged to include pattern drafting for sheet metal workers in general.

The course represented by this textbook comprises three divisions, namely:

Part 1. Parallel Line Developments.

Part 2. Radial Line Developments.

Part 3. Triangulation.

All told, there are 235 exercises, and in arranging the course of study, heed has been given to the selection of problems of practical utility. The course covers, thoroughly and concisely, the principles which underlie pattern drafting, and, supplemented by the verbal instruction imparted by the teachers, will enable the student to prepare the patterns for the usual forms arising in sheet metal work.

Before entering upon the studies in this textbook, a short course in elementary geometry is provided.

PRELIMINARY

Each illustration shows how many times the problem is to be enlarged when drawn by the student. Thus (E 2x) means enlarge twice; (E 3x) enlarge three times, and so on. All drawings will then be of ample proportions to clearly show all points of intersection, and to permit each step in the development of the pattern to be easily shown.

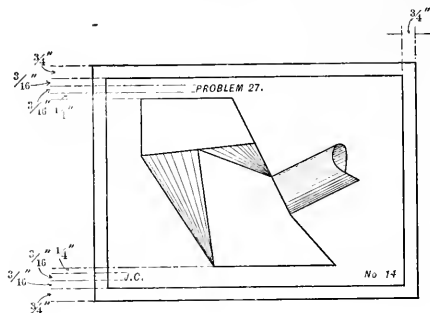

FIG. 1.

The letters and numerals of the pattern need not be reproduced on the student's own drawing, unless he otherwise desires.

Each plate must have marginal lines as illustrated in Fig. 1, together with the proper lettering. The number of problems to be placed on each plate, will be governed by the size of the respective drawings. Over the center of each drawing, the word "Problem" and its "Number" is to appear, the problems as developed being numbered consecutively by the student. At the bottom of the plate to the left, the student should place his name, and to the right, his class number. Have a space of $\frac{1}{4}$ " between all lettering



FIG. 2.

and the drawings. Letters and numerals to be drawn on an angle of 60° . Fig. 2 shows style of lettering desired. All the patterns illustrated are net. That is, no allowance has been made for a lap for the purpose of soldering, seaming or riveting.

Before starting a problem, the text should be carefully read by the student, so as to acquire an intelligent conception of the drawing he is to undertake.

PART ONE—PARALLEL LINE DEVELOPMENTS

Under this head comes all patterns that can be developed by means of parallel lines. This method is one of the most simple that can be used in getting out the pattern of any form the opposite lines of which are parallel, such as piping, flaring ware with parallel bends, mouldings, skylights, etc. There are certain fixed principles that apply to developments by this method, and they are set forth in connection with Fig. 3, *viz.*:

1. There must be an elevation or plan *A*, showing the line of joint or miter line *B C*.
2. In line with either the plan or elevation, the section or profile *D* of the article to be developed must be drawn, and if curved, must be divided into any convenient or equal number of spaces as shown from 1 to 10. From these points, lines are projected to the miter line, parallel to the lines of the article.

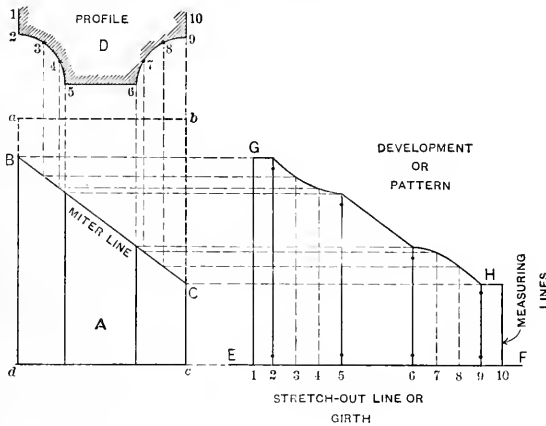

FIG 3.

3. At a right angle to the plan or elevation *A*, draw the line *E F*. This is the stretch-out line or girth. Upon this line, reproduce the measurements 1 to 10. This gives, in the flat, the length of material required to bend the profile *D*.

4. At a right angle to the stretchout line *E F*, and from points 1 to 10, erect measuring lines, which are then intersected by lines, drawn at a right angle to the lines of the article *A*, from similar intersections on the miter line *B C*.

5. A line then traced through intersections thus obtained, as shown by *E F H G*, gives the desired pattern.

It is immaterial what shape the section or profile may be; or whether the merit

line BC is straight, curved or irregular, the principle is similar in all cases. Suppose $abcd$ to be a zinc moulding, in shape similar to the profile D , and that a piece is cut from it with a saw, on the line BC . If the lower portion A is now drawn apart and flattened, the shape will be the same as the pattern $EFGH$. Thus it will be seen that the principles of parallel line development is to find the true girth, and on the measuring lines erected therefrom, place the various lengths obtained from the intersections on the miter line.

While some of the problems appearing in Part One require also a knowledge of projection, that subject will be explained when such problems are reached.

PATTERNS FOR VARIOUS PIECED ELBOWS

FIG. 4. Shows patterns for a two and three-pieced elbow, also for an elbow at any angle, all having the same plan or profile.

First draw the elevation of the two-pieced elbow as shown by $AB C D E F$. In line with one arm of the elbow, place the plan G , after which, draw the diameter 1-7. As both halves of the plan are symmetrical, divide the upper half only into equal parts as shown from 1 to 7. From these points, erect vertical lines, intersecting the miter line CF as shown. Extend the line DE as shown by $\check{y}K$, and upon this line place the stretchout of the full plan, as shown by similar figures on $\check{y}K$. From these points, and at a right angle to $\check{y}K$, erect lines as shown, which intersect with lines drawn at a right angle to FE from like numbered intersections on the miter line CF . Trace a line through points thus obtained, then will $\check{y}KL$ be the pattern for one of the arms of a two-pieced elbow. This method can be used for any pieced elbow, no matter what the angle may be. There is another method for getting out a two-pieced elbow having an angle of 90° , and the pattern can be developed without using the elevation or miter line, *viz.*: After the stretchout $\check{y}K$ has been obtained, and knowing the length of the throat as $K1$, it is only necessary to place the profile of half the pipe on the line $K1$ extended to 7, and as shown by H , and, dividing H into similar parts as G , horizontal lines are drawn, which intersect vertical lines drawn from $\check{y}K$, resulting in a shape similar to that obtained from the miter line. As previously stated, this rule is applicable only to two-piece elbows, constructed at a right angle, and it does not matter what shape the pipe may have.

The elevation of a three-pieced elbow is shown by $MNO P R S T U$ and is drawn as follows: First draw the right angle MVP , and knowing the depth of the throat VR and the diameter of the pipe RP , use V as center, and draw the quadrants or quarter circles RU and PM . From P and R erect vertical lines, and from M and U draw horizontal lines, which are to intersect lines drawn at an angle of 45° tangent to the two quadrants, thus obtaining the intersections N , O , S and T . From N and O draw the miter lines toward V as shown. Then $PRSO$ and $TUMN$ are each one half

of $N O S T$. From the various intersections in the plan G , lines (not shown) are erected until they intersect the miter line $S O$. From here, the same steps are followed as in the two-pieced elbow, and the pattern shown by $W X Y$ is obtained. $W X Y$ represents the pattern for both the top and bottom pieces of the elbow. By reversing the pattern

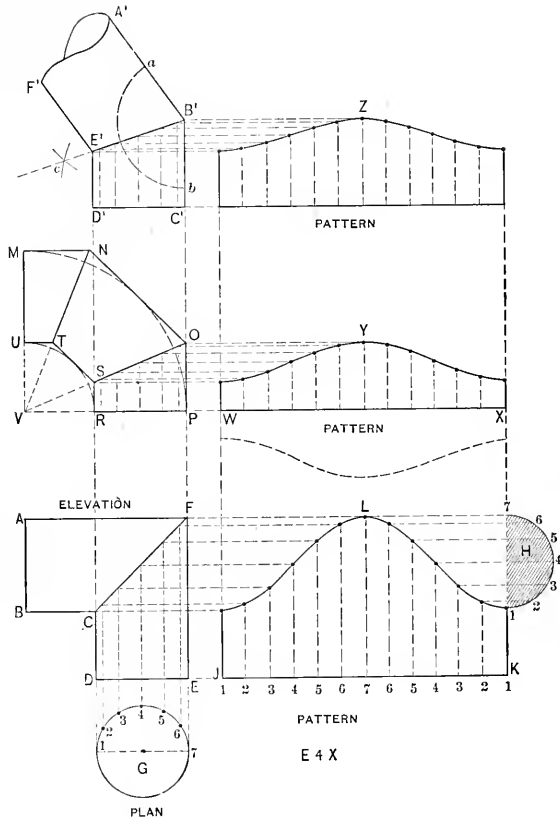

FIG. 4.

and tracing it opposite the line $W X$, as shown by the dotted line, the pattern for the middle piece is obtained. No matter how many pieces an elbow may have, the pattern for either end is always one half the pattern for the other pieces.

When an elbow must be made to fit a certain angle, the method of obtaining the miter line is as follows: Let $A^1 B^1 C^1$ be the desired angle. With B^1 as center and any convenient radius, describe the arc $a b$. With a and b as centers and a radius slightly

larger than before, draw arcs intersecting at c . Then draw the miter line $B^1 c$, and knowing the diameter of the pipe, draw the lines $D^1 E^1$ and $E^1 F^1$ parallel to $C^1 B^1$ and $B^1 A^1$. The pattern Z is then obtained in the manner already explained.

When obtaining the patterns for pieced elbows, it is not necessary to draw the entire elevation to obtain the rise of the miter line, as was done in the three-pieced elbow. By a simple rule, and with the aid of the protractor, the rise of the miter line can be found, no matter what the throat or diameter of the elbow may be. If the pattern for a six-pieced elbow had to be laid out, the throat of which was 30 inches and diameter 20 inches, it would hardly be practicable to first draw the full quadrant in order to obtain the rise of the miter line. Using the protractor as illustrated in Figs. 5 and 6, much time can be saved over the method shown in Fig. 4. As a rule, all elbows join together and form an angle of 90° no matter how many pieces they contain. The angle at which the elbow is to be connected, forms the basis by which the rise of the miter line is computed.

FIG. 5. Shows a three-pieced elbow, which, when completed, should have an angle of 90° . As the middle section B equals twice A , then 4 will be the divisor for 90 . $\frac{90}{4} = 22\frac{1}{2}$. Thus the first miter line will have a rise or angle of $22\frac{1}{2}^\circ$. As $B = 2 \times A$, the second miter line will be drawn at an angle of $67\frac{1}{2}^\circ$. We then have $22\frac{1}{2} + 45 + 22\frac{1}{2} = 90$. Therefore in all elbows of no matter what angle, the following rule should be followed, *viz.*: For each of the end pieces count 1, and for each of the other pieces count 2.

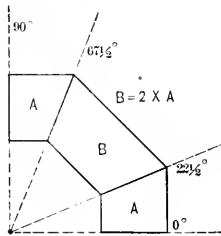

FIG. 5.

FIG. 6. Illustrates how the protractor is used. Assuming that patterns are wanted for 2, 3, 4, 5, 6 and 7-pieced elbows, each having a throat measurement of 15 inches, and a diameter of 6 inches, the elbows when finished to have an angle of 90° , we would proceed as follows: Extend the line of the base of the protractor as shown by $A C$. Make $A B$ 15 inches and $B C$ 6 inches, and from B and C erect vertical lines of indefinite length. As a two-pieced elbow has but two end pieces and the angle when completed is to be 90° , then $\frac{90}{2} = 45$ or the degree at which a line must be drawn from the center A until it intersects the vertical lines of the pipe at D . This line will be the miter line for a two-pieced elbow. For a three-pieced elbow, the two end pieces count 2 and the

middle piece counts 2 which equals 4; $\frac{90}{4} = 22\frac{1}{2}$ or the degree at which a line will be drawn from A, as shown by A E. In similar manner, also shown in Fig. 6, we obtain the rise of the miter line for 4, 5, 6 and 7-pieced elbows. For example, a seven-pieced elbow is desired. The two end pieces count 2 and the other five pieces 10; $2 + 10 = 12$;

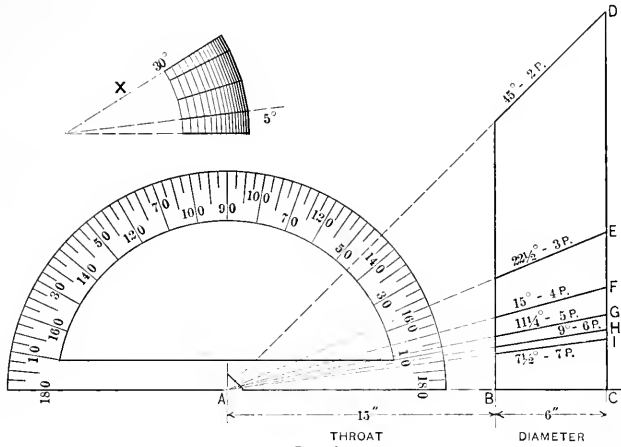

FIG. 6.

$\frac{90}{12} = 7\frac{1}{2}$, which represents the angle of the miter line. If a four-piece elbow was to be made, having an angle of 30° , as shown by X, the same rule is employed. The two end pieces count 2 and the other two pieces count 4. $4 + 2 = 6$; $\frac{90}{6} = 15^\circ$, or the angle of the miter line, as shown.

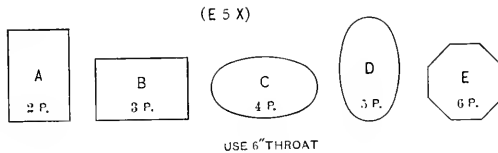

FIG. 7.

FIG. 7. Using the protractor by which to obtain the angle of the miter line, lay out the patterns for a 2, 3, 4, 5 and 6-pieced elbow, the respective profiles or sections being as per outlines A, B, C, D and E in Fig. 7. Each elbow to have a 6-inch throat and an angle of 90° . The patterns for the end pieces only are required, similar to W X Y in Fig. 4.

FIGS. 8 and 9. Here is shown the method of drawing the elliptical figure when the length and width are given. These two rules appear in many text books, and are repeated here because of their simplicity. If an ellipse is required with length equal to AB in Fig. 8 and width equal to CD , then take the distance from C to D and place it from B to a , and divide aA into three equal spaces, as shown by b c . With a radius equal to two spaces, and with E as center, describe the arcs on AB at e and d . With

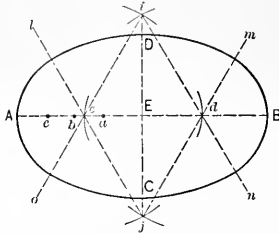

FIG. 8.

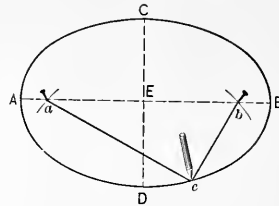

FIG. 9.

a radius equal to ed and with e and d as centers, describe arcs intersecting each other at i and j . Draw lines from i and j , through d and e as shown. Then i and j are the centers from which are drawn the arcs no and lm , and e and d the centers from which are drawn the arcs ol and nm . This ellipse is constructed from four center points and is of value in laying out flaring work when the centers, from which the arcs are struck, must be known. In the case of elbows, when the center points have no value and the ellipse is large, the figure can be constructed with string and pencil as illustrated in Fig. 9, in which half of AB is taken as radius, and with C or D as center, arcs are drawn on AB , as shown by a and b . At a and b stick two pins and make a loop around the pins with a string, so that when the pencil draws the string taut, the pencil point will meet D . With the pencil in position, as shown at c , describe the ellipse, allowing the string to guide the pencil point. These methods of drawing the ellipse should be used in connection with the problems shown in Fig. 7.

PATTERNS FOR VARIOUS INTERSECTING PIPES

FIG. 10. Shows the intersections and patterns of a round and square pipe at right angles, the round pipe being placed over the angle of the square pipe. The profile of the square pipe is indicated in the end view by $ABCD$, and in the side view, by $EFGH$. \checkmark and K show, respectively, the positions of the round pipes in both views. Above \checkmark and K in their proper positions draw the profiles of the round pipes as shown by L and L' . Divide both into equal spaces being careful that if 1 and 7 are at top and bottom in L , they will be at the sides in L' , because each represents a different view. From the various points in L , draw lines parallel to the pipe \checkmark until they intersect the

sides $B A$ and $A D$ of the square pipe. From these intersections draw horizontal lines, which in turn are intersected by vertical lines drawn from similar points in the profile L , resulting in the miter line $U V W$. The pattern for the round pipe is obtained by drawing the horizontal line $1^{\circ} 1'$, upon which, the stretchout of the full circle is placed, as shown. From the various points on $1^{\circ} 1'$, drop vertical lines, which intersect by lines drawn from similar points on the sides $B A$ and $A D$. Trace a line, as shown by $M N O$, and the desired pattern is secured. To get out the pattern for the opening in the square pipe, take the stretchout of the various points on $B A D$ and place them on $F G$, extended as $B^1 D^1$. Draw the measuring lines, as shown, at right angles to $B^1 D^1$, which intersect by vertical lines extended from similar intersections in the miter line $U V W$. Trace a line as shown by $P R S T$, which gives the desired opening.

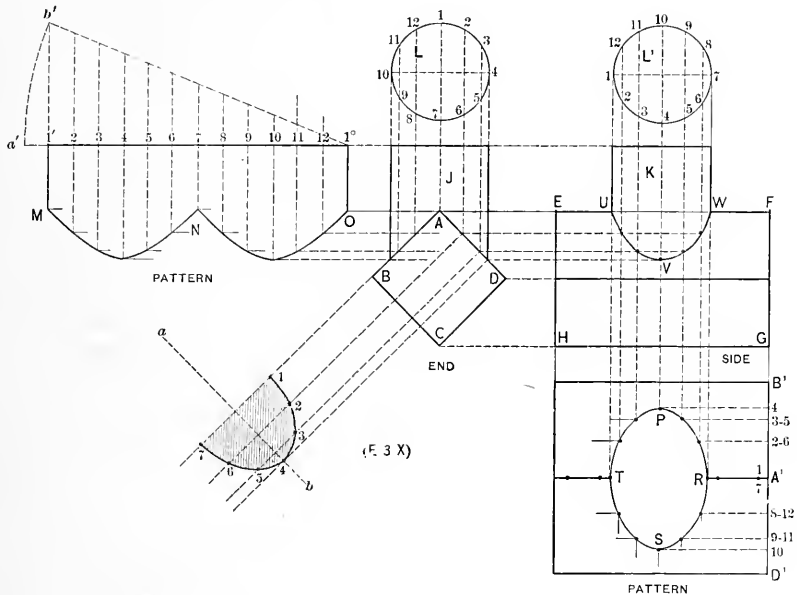

FIG. 10.

This opening can also be obtained from the end view as follows: At right angle to $A D$ from the various intersections, project lines indefinitely as shown, and at a right angle to these lines draw a line as $a-b$. Then measuring from the line 4-10 in the profile L , take the various distances to points 1, 2 and 3, etc., and place them on lines having similar numbers on either side of the line $a-b$. The shaded portion represents half of

the opening. When sheet metal work is constructed from No. 20 to 30 gauge metal, it is not customary to allow for its thickness in the development of the pattern, but when heavier gauge than No. 20 is used, it is the practice to increase the stretchout. Some mechanics allow 3.1416 times the thickness of the metal, while others allow four and six times the thickness. The best practice is to allow seven times the thickness. Whatever the allowance may be, the rule for setting it proportionally throughout the stretchout is as follows: Suppose the pipe \tilde{y} was to be constructed of $\frac{1}{4}$ -inch metal, then $7 \times \frac{1}{4} = 1\frac{3}{4}$; the extra allowance to be placed on the stretchout line from r' to a' . Then using r' as center and $r'a'$ as radius, an arc is struck until it intersects the vertical line at b' erected from r' . Draw a line from b' to r' and erect lines as shown. This divides $b'r'$ into equal parts, which line is then used the same as $r'r'$ in developing the pattern when heavy metal is to be used. When a complete circle is employed, seven times the thickness of the metal must be added to the stretchout. If a half or a quarter circle is employed, one-half or one-quarter of seven times the thickness is added to the stretchout. Whatever the fractional part of the profile may be, similar fractional amount is added to the stretchout. This feature will be taken up as we proceed.

FIG. 11. Applying the method given in Fig. 10, develop the patterns for the T-joint in Fig. 11, when the pieces A and B are at a right angle, also when A is at an angle of 45° , as shown at C . The method of obtaining the miter line on side is easily ascertained by referring to like letters and figures in both views.

FIG. 12. Shows a Y the diameter of each branch being the same. The miter line $a e$ is obtained by bisecting the angle $b a c$ by the line $d e$. A is the profile.

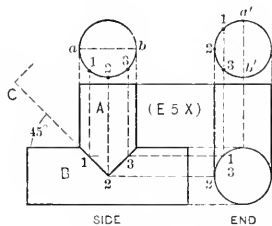

FIG. 11.

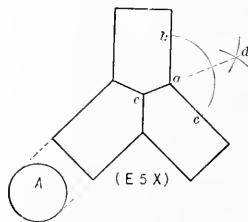

FIG. 12.

FIGS. 13 and 14. Show pipes of different diameters, the vertical pipe in one case being placed in the center and in the other to one side of the horizontal. Also at right angle and at an angle of 45° , as shown by the solid and dotted lines respectively.

Note how the miter lines on the side are projected. In the problems in Figs. 13 and 14 where the intersections are at right angles to each other, the small and large pipes A and B in both figures are to be constructed from $\frac{1}{4}$ -inch metal, and the patterns

for the vertical pipes *A* are to be developed as shown in Fig. 10. In order that the method of allowing for the thickness of the metal in the opening in the horizontal pipe may be understood, the pattern for the opening in *B* in Fig. 14 has been prepared. Take the stretchout of 1-2-4-3 in end view and place it on *a-b* as shown. As the smaller pipe intersects one-quarter of the circumference of the larger pipe, and assuming that $\frac{1}{4}$ -inch metal is used, then take one-fourth of $7 \times \frac{1}{4}$ or $\frac{7}{16}$, and place it on *a-b* from 3 to *c*. With *r* as center, draw the arc *c 3'*, which intersect by a line drawn from 3. Draw a line from *3'* to *r*, which intersect by a line drawn from 2-4. Take the stretchout of *3' b* and place it on *d e* as shown. Draw the usual measuring lines and obtain the opening shown by the shaded lines. In finding the opening in Fig. 13, measurements

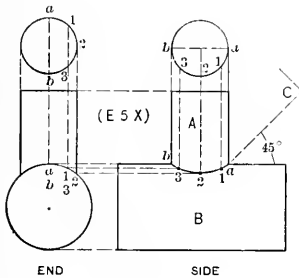

FIG. 13.

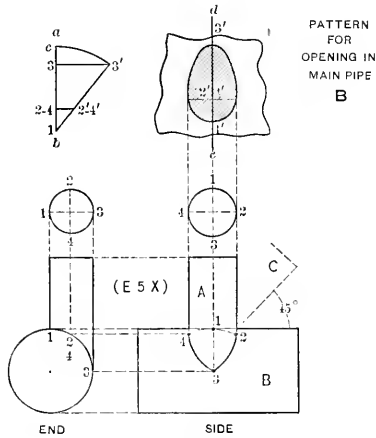

FIG. 14.

are taken in the end view, to ascertain how much of the circumference is intersected by the small pipe, and if it be one-fifth, then one-fifth of $7 \times \frac{1}{4}$ is to be added to the stretchout.

FIG. 15. Shows the intersections between a rectangular and round pipe for which patterns are to be obtained in accordance with principles already explained.

PATTERNS FOR PIPES INTERSECTING PITCHED ROOFS

FIG 16. Shows the method of obtaining the patterns for the pipe and roof flange when the pipe passes through one side of the roof. *A B* shows the pitch of the roof, *C* the side view of the pipe and *D* its section. The section is divided into equal parts as shown, and the pattern *E* obtained in a manner similar to the development of elbow

patterns. To obtain the pattern for the roof flange, or the opening to be cut in the roof, draw lines at right angles to AB from the various intersections 1 to 5. On the line 1-3 place half of section D , as shown by D^1 , which divide into equal spaces to correspond to D . From these points in D^1 draw lines parallel to AB , intersecting similar lines extended from $A B$. A line traced through the points as shown will be the desired opening. A more simple way of obtaining this roof opening is to use the method given in Fig. 9. The size of the flange required should be added around the opening just obtained in Fig. 16.

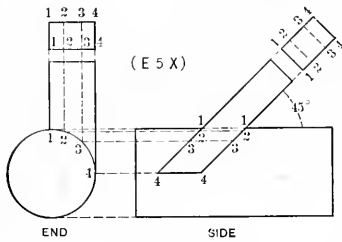

FIG. 15.

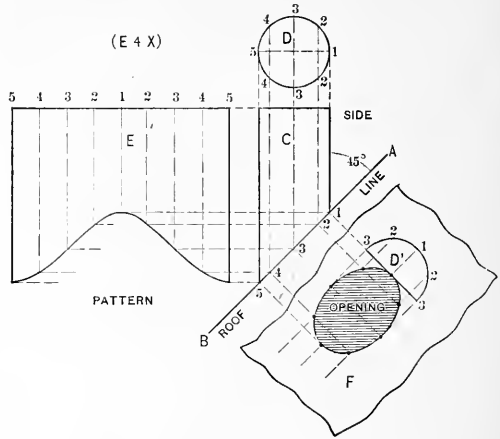

FIG. 16.

FIG. 17. When a pipe is to set over the four hips of a roof, the patterns are obtained as shown in Fig. 17. ABC shows the pitch of the roof, and $DEFG$ the plan view. Draw the plan of the hips GE and DF . In this case an octagon shaft or tube is to be used as shown in plan by H and in elevation by A . As the pattern for one-quarter answers for all four sides, then number all corners and intersection at the hips alike, as shown by 1, 2, 2, 1, etc. From these points drop lines intersecting the pitch AC . From the intersections on AC , draw horizontal lines to meet lines drawn vertically from similar numbers in plan as shown, thus giving the miter line in elevation. This miter line is not necessary in developing the pattern, but is shown here to explain the method of projecting the miter line, no matter what shape the pipe, or what pitch the roof may have. The pattern for the octagon pipe is shown by γKLM and is like similar developments already gone over. To obtain the pattern for the opening in one side and the pattern for one side of the hip roof, take the stretchout of $A 1 2 B$ in elevation and place it at right angles to DE in plan as shown by $A^1 1 2 B^1$. Through these

points, draw vertical lines to intersect horizontal lines drawn from similar numbers in plan, resulting in the pattern shape shown.

FIGS. 18 and 19. Show respectively a cylinder passing through a double pitched roof, and a cylinder setting on a hipped roof. In each case the patterns for both cylinder and roof openings are to be developed.

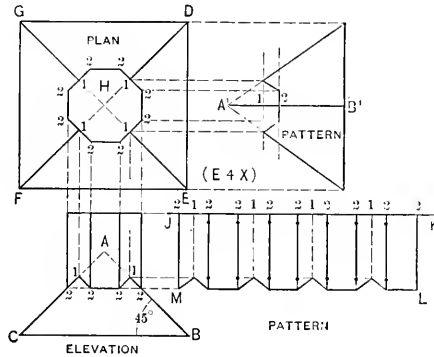

FIG. 17.

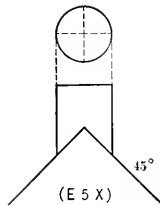

FIG. 18.

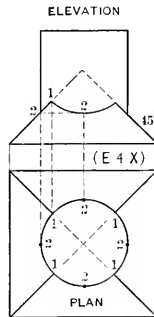

FIG. 19.

INTERSECTIONS BETWEEN VARIOUS SHAPED SHAFTS AND SPHERE

FIG. 20. In ornamental sheet metal work it often happens that moulded shafts or mouldings will miter against a sphere at various angles. When the shape of the shaft is round or square, or the shape is such that each of the sides are symmetrical and the shaft miters directly over the center of the sphere, then the patterns can be developed as shown in Fig. 20, in which the sphere in plan is struck from A as center, and the

various arcs forming the shaft are struck from a , b , c and d . With B as center, draw the elevation of the sphere. Then divide the quarter plan of the shaft as shown, from which points drop perpendicular lines intersecting the sphere in elevation at 1, 2 and 3. From these intersections, carry lines at right angle to the center line, until they intersect CD at $1'$, $2'$ and $3'$. Then, using B as center, with radii equal to $B1'$, $B2'$ and $B3'$, draw arcs to meet vertical lines drawn from similar numbered intersections in the opposite quarter plan of the shaft, resulting in the miter line between the shaft and sphere, shown

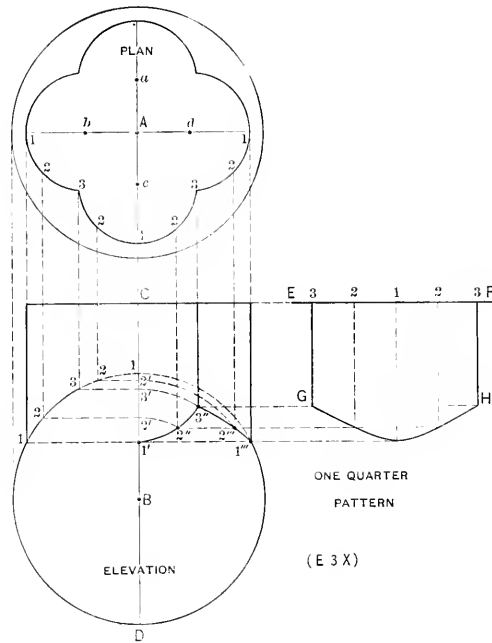

FIG. 20.

by $1'$, $2''$, $3''$, $2'''$ and $1'''$. In this problem, as well as in others which will follow, the line of intersection or miter line must first be obtained before the pattern can be developed. It is, therefore, important that the student bear in mind the method of projecting the miter line. After the miter line has been obtained, draw the stretchout line EF , upon which place the stretchout of one-quarter of the shaft in plan as shown by the duplicate numbers on EF . Draw the measuring lines in the usual manner, to intersect lines drawn parallel to EF from similar numbers in the miter line. Then $EFHG$ is the pattern for one-quarter of the shaft.

FIG. 21. When the shaft or moulding intersects the sphere to one side of its center, as in Fig. 21, the miter line and pattern are obtained by means of horizontal planes drawn through the sphere. In this case the intersection is between a moulding placed at an angle of 45° , and a sphere. Draw the elevation of the sphere *B*, and at an angle of 45° , draw the outline of the moulding *LMG*. Below the elevation draw the section of the sphere *A*, upon which, in its proper position, draw the section of the mould as shown. It will be noticed that the rear of the mould touches the center line of the sphere. With *A* as center and the bends in the mould as radii, draw the concentric semi-circles shown. Establish a few other points at pleasure so as to obtain intermediate points in the profile, and draw semi-circles as shown, intersecting the center line at *a*, *b*, *c*, *d* and *e*. These semi-circles then represent horizontal planes, which are projected

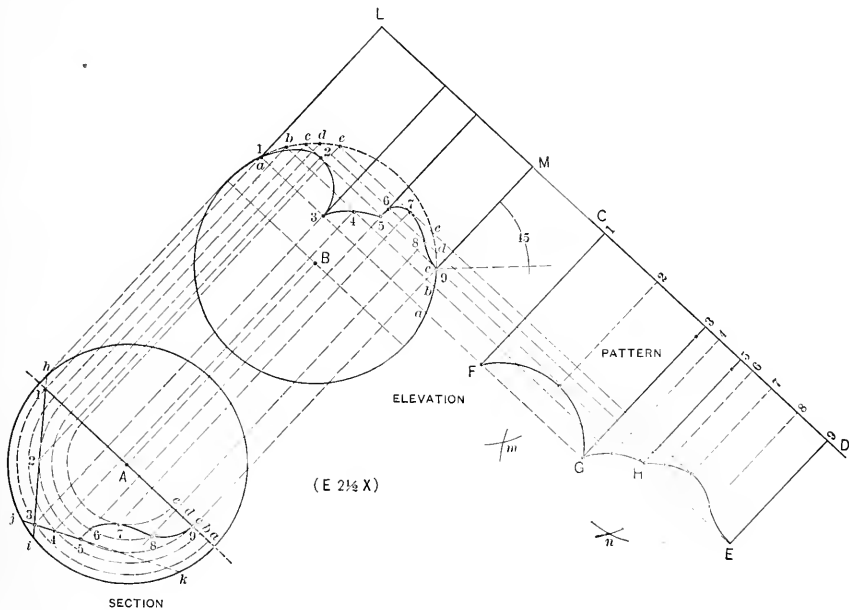

FIG. 21.

into the elevation by drawing lines at right angle to *ha* in section until they intersect the sphere in elevation at *a*, *b*, *c*, *d* and *e*. From these intersections, lines are drawn parallel to *LM* as shown. As the points 1 and 3 in the section intersect the plane *a*, then project the points 1 and 3 until they intersect similar points in plane *a* in elevation at 1 and 3. In the same manner project points 2 to 9. Trace the miter line through points thus obtained in elevation as shown. The pattern is developed by extending

the line LM , as CD , upon which place the stretchout of the mould in section, being careful to measure each space separately because they are all unequal. Measuring lines are now drawn and intersected as shown, resulting when traced in the pattern $CDEF$. As any plane section through a sphere is a circle, then it is evident that one-half of ih in section is the radius with which to complete the arc FG in the pattern. Therefore take one-half of ih as radius, and with F and G as centers, intersect arcs at m , which is the center point from which to get the arc FG . In similar manner find the center n , by using as radius one-half of jk in section.

FIGS. 22 and 23. Applying the method given in Fig. 20, develop the patterns for the shafts shown in Figs. 22 and 23, representing a square and octagonal shaft, mitering over the center of a sphere. In these two problems, as well as the two which follow, all points of intersection have similar letters and numbers.

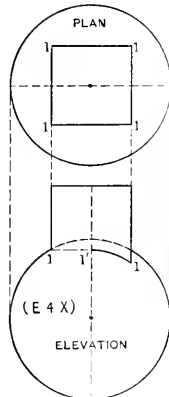

FIG. 22.

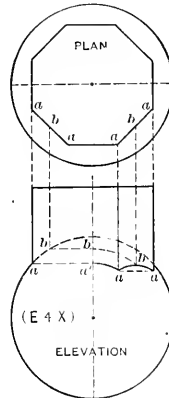

FIG. 23.

FIGS. 24 and 25. A round shaft placed to one side of the center of a sphere is shown in Fig. 24, and in Fig. 25 a square shaft is set diagonally past the center of the sphere. Develop the patterns for each problem, following the method explained in connection with Fig. 21. The miter line in Fig. 25 is not completed, the three points of intersections only being shown. These three points are all that is necessary in developing the pattern. The arcs between these points in the pattern are to be obtained by using one-half of de and hi in plan as radius.

PATTERN FOR FLARING PAN

FIG. 26. When the pattern for a flaring pan is required, the corners of which are to be made watertight by folding together and turning them to the sides or ends of the

pan, it is necessary to know how much must be notched from the corners, so that when folded they will come directly under the wired edge of the pan. This is accomplished in the manner illustrated in Fig. 26, the pattern being shown for a pan in which the

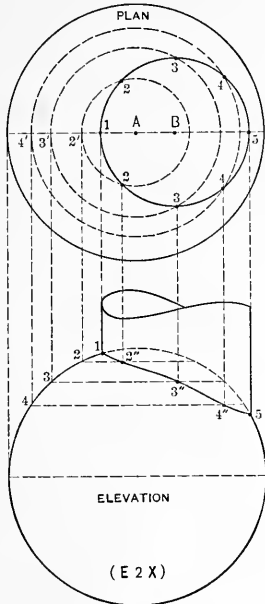

FIG. 24.

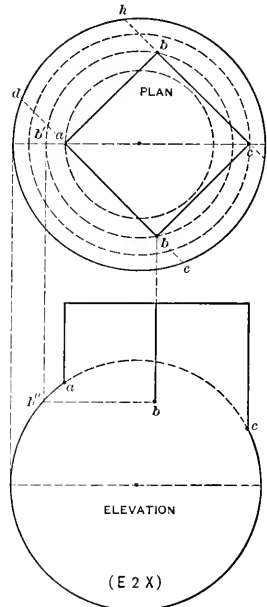

FIG. 25.

sides have more flare than the ends. Let $ABCD$ be the bottom of the pan. The end and side views are also drawn as shown, the vertical heights Fa and Ia' being the same. Thus $EFGH$ is the end view, and $I'JKL$ the side. Extend AB as BM , which is made equal in length to FG in end view. Through M , parallel to BC , draw the line PU , which intersect by lines drawn from K and L in side view and at a right angle to PU . Connect the corners C to U and P to B . In similar manner extend CB as BN , which make equal in length to IL in side view. Through N draw the line VO , which intersect by vertical lines drawn from H and G in end view. Draw VA and BO . Trace similar miters on opposite side and end as shown. Then will $VOPUTSRiABCD$ be the pattern for the pan if the corners were to have a raw edge. It will be noticed that the miters OB and BP have different angles, but have similar lengths as shown by the arc OP , struck from B as center. Assuming that the corner is to be turned towards the end of the pan, then bisect the angle OBP , obtaining the line of bisection bbB . Now with O of the end miter as center and with a radius less than would touch bbB , draw the arc cd , intersecting OB

at e . With e as center and ec as radius, intersect cd at d . Draw a line from O through d , meeting bb at f . From f draw a line to P . Then OfP is the amount to be notched from the corner, when it is turned towards the end. When the corner is to be turned towards the side, the operations are similar, excepting that i is used as the center in

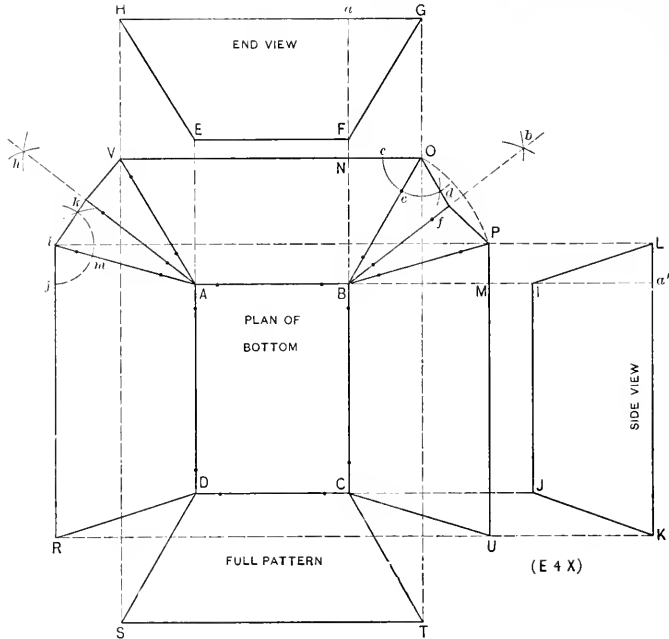

FIG. 26.

transferring the angle ijm . By referring to the various letters, the operation is easily followed.

FIG. 27. Shows two other styles of pans. A is to have equal flare all around, while B will have no flare, the bottom of the pans to be square.

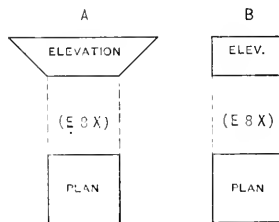

FIG. 27.

PATTERN FOR TRANSITION PIECE

FIGS. 28 and 29. The former shows the rule for obtaining patterns in piping when the lower pipe, in passing up, has to fall over and twist one-quarter way around to pass through given points. The principle is similar to Fig. 26 in the mitering of unequal flares. Thus in Fig. 28 *NOPR* is the lower pipe, which is to turn in the position shown by *JKLM*. The front view is shown by *ABCD* and the side view by *EFGH*. *EF* in side view represents the measurement of material required for the side 1 in plan, *DC*

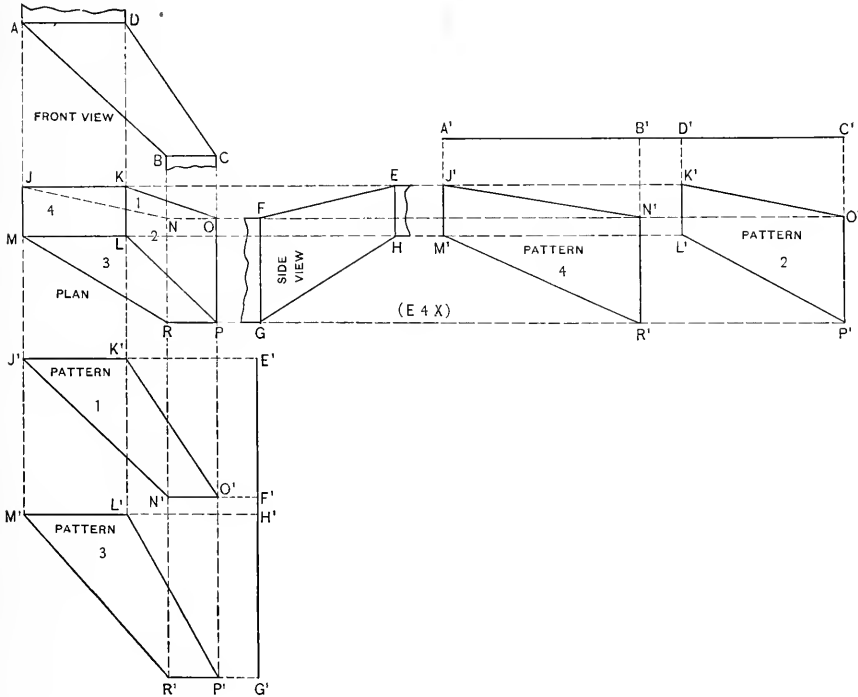

FIG. 28.

in front for side 2, *HG* for side 3 and *AB* for side 4. Having the plan, front and side views drawn in their proper positions, the patterns for sides 1 and 3 in plan are obtained as follows: Draw any vertical line as *E'G'*, upon which place the stretchout of *EF* and *HG* in side view, as shown respectively by *E'F'* and *H'G'*. From these points draw lines at a right angle to *E'G'*, which intersect by lines drawn from corresponding points

in plan. Trace lines through the various points obtained. Then will $\overline{J^1K^1O^1N^1}$ and $\overline{M^1L^1P^1R^1}$ be the patterns for the sides, having similar letters in plan. In a like manner obtain the patterns for the sides 2 and 4 in plan, as shown by the patterns marked 2 and 4. When these transition pieces are large they are gotten out in four separate parts and double-seamed at the corners. If the size is such that they can be conveniently made from one piece of metal, then the various patterns are joined, as shown in Fig. 29.

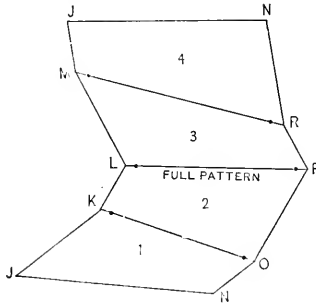

FIG. 29.

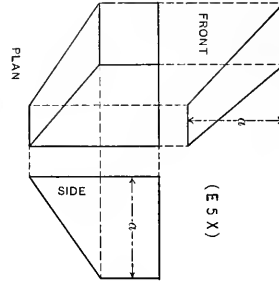

FIG. 30.

FIGS. 30, 31 and 32. Are three problems to be solved according to the principle given in Fig. 28. Fig. 30 shows a transition piece, the base of which is oblong and top square, the vertical height a being equal. Fig. 31 shows an offset with equal dimensions at top and bottom. Fig. 32 shows similar pipes crossing each other. Each side is to be developed separately and then joined in one full pattern as shown in Fig. 29.

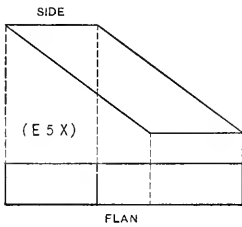

FIG. 31

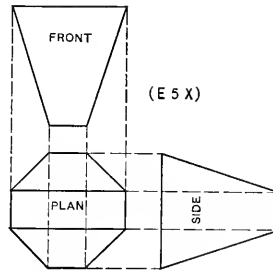

FIG. 32.

PATTERN FOR SCALE SCOOP

FIGS. 33 and 34. When developing patterns for various shaped scoops, the parallel line method should be employed. Under this method the various shapes are cut from

a cylinder or part of a cylinder as shown in Fig. 33, *AB* representing the cylinder and *C* and *D* scoops of different shapes cut from same. In the scoop *C*, the miter line takes up but part of the cylinder. Fig. 34 illustrates how the pattern is obtained. First

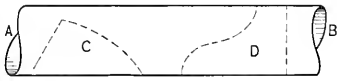

FIG. 33

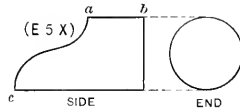

FIG. 35

draw the elevation of the scoop as shown by *ABCD* and extend *CD* as *CF*. At a right angle to *CF*, from any convenient point, draw the line *FE*, upon which at pleasure establish the center point *H*, so that *FH* will be the required radius with which to draw the arc $\tilde{F}HK$. As both halves of the section are symmetrical, then divide one-half into equal spaces, from which points and parallel to *CD*, draw lines intersecting the outline *DB* and miter line *BC*. At a right angle to *CD* draw the stretchout line *LM* upon which

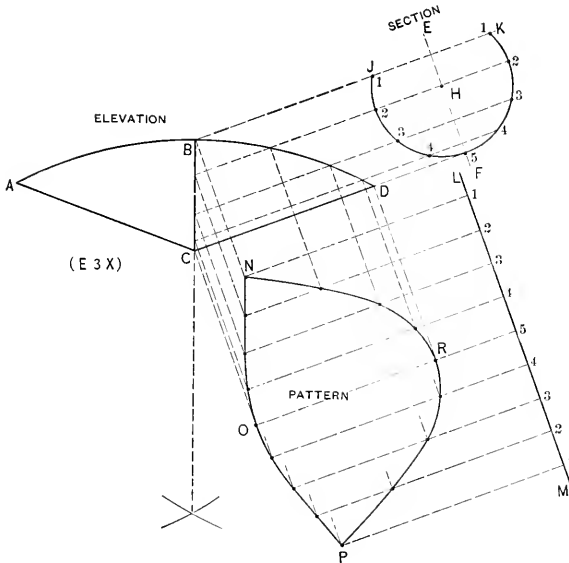

FIG. 34.

the full stretchout is placed as shown. The pattern *NOPR* is then developed in accordance with the principles with which the student should now be familiar.

FIG. 35. Shows a hand scoop. The section is a full circle from *a* to *b* and an irregular curve from *a* to *c*. Full patterns are required.

PATTERN FOR PIPE INTERSECTING ELBOW MITER

FIGS. 36 and 37. When a branch must be taken from the angle of an elbow, the rule to be employed is shown in Fig. 36. It does not matter what size the branch or elbow may have, or how many pieces the elbow contains, or whether the branch is placed in the center of the elbow or to one side, the principle explained applies in each case.

Let A , in plan, represent the center from which the circle $B, C, 1, 5$ is struck, being the profile of the elbow shown in elevation by $KLHG$, $\tilde{y}1'$ representing the miter line of the 45° angle. Draw the plan of the branch in its desired position as shown by $1DE5$; also its profile shown by F . Assuming that the center line of the branch in elevation is to fall upon the corner $1'$, at an angle of 90° to the line of the elbow $L1'$, draw the line $1'1$ indefinitely, upon which establish the center F^1 , and draw the profile in size equal to F in plan. Divide both of the profiles F and F^1 into the same number of spaces, being careful that if 1 and 5 represent the sides of the branch in plan, they will be placed in their relative positions in elevation. Parallel to the line $5-E$ in plan and from the various intersections 1 to 8 in F , draw lines intersecting the circle A at 1, 2-8, 3-7, 4-6 and 5. From these intersections draw vertical lines intersecting the miter line $\tilde{y}1'$ as shown, from which points parallel to $1'L$, draw lines indefinitely. Now from the various intersections in the profile F^1 parallel to $1-1'$, draw lines intersecting similar numbered lines drawn from the plan, resulting in the points of intersections shown in elevation by $1', 2', 3', 4', 5', 6', 7'$ and $8'$. Trace the curved line of intersection from $4'$ to $3'$ to $2'$ to $1'$ to $8'$ to $7'$ to $6'$ to $5'$. It is evident that before a line can be traced from $5'$ to $4'$, the point of intersection b must first be found between the branch and the miter line $\tilde{y}1'$. To find this point it is only necessary to assume that the portion of the elbow $K\tilde{y}1'L$ is a straight cylinder, on to which the half profile F^1 from 1 to 5 is to be mitered. Therefore extend the line cd (which represents the line taken from the point 5 in plan) indefinitely, which intersect by a line drawn from point 5 in the profile F^1 , and obtain the intersection $5'$. Then trace a line from $4'$ to $5'$, intersecting the miter line $\tilde{y}1'$ at b , the desired point. From b , parallel to the branch, draw a line intersecting the profile F^1 at b' ; also drop a vertical line, intersecting the plan A at b'' . These points will be used when developing the patterns. Trace a line from $4'$ to b . It is also evident that the line from b to $5'$ must be curved, as the profiles of both pipes are circles. Therefore at pleasure, establish on the line GH in elevation between the points $5'$ and b any point as a , through which draw the vertical line intersecting the plan A at a' . From this point, parallel to $5E$, draw a line intersecting the profile F at a'' . Take the distance from 5 to a'' and place it from 5 to a''' in the profile F^1 , from which point, parallel to the lines of the branch, draw a line intersecting similar line at a''' . Draw a line from b through a''' to $5'$, which completes the miter line between the branch

and elbow. In the illustration the patterns are only shown for the openings to be cut from the elbow patterns; but in drawing this problem the student is to develop the full patterns for the various pieces with seam at *B* in plan. To obtain the pattern for the opening in $\tilde{y}GH1'$, extend the line *GH* as *HM*, upon which place the stretchout of the necessary spaces in 5-1 in plan *A* as shown. Erect vertical lines from *HM*, which intersect by horizontal lines drawn from similar intersections in elevation. Trace a line

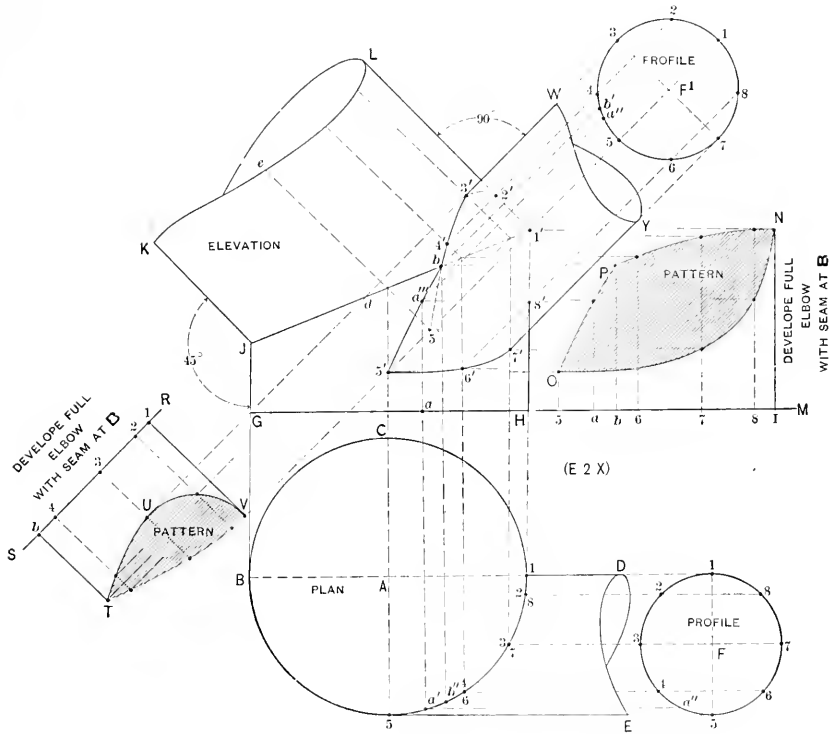

FIG. 36.

through points thus obtained, then *PON* or the shaded portion is that part to be cut out of the full elbow pattern to admit the mitering of the branch. In similar manner obtain the opening for the piece $\tilde{y}KLI'$. At right angle to $\tilde{y}K$ draw the line *RS*, upon which place the stretchout of the required spaces in that portion of the plan *A* shown from *b''* to *1*. Draw perpendicular lines from *SR*, which intersect by similar numbered lines drawn from the elevation at right angles to $\tilde{y}K$. *TUV* or the shaded portion is

the desired opening. To avoid a confusion of lines, a tracing of the branch $W3'5'Y$, with the various intersections, has been placed horizontally in Fig. 37. This pattern is obtained by drawing the vertical line AB upon which the stretchout of the profile F^1 in Fig. 36 is placed, as shown in Fig. 37. Horizontal or measuring lines are drawn, which are intersected by vertical lines drawn from similar numbered intersections in WY , resulting in the pattern CDE .

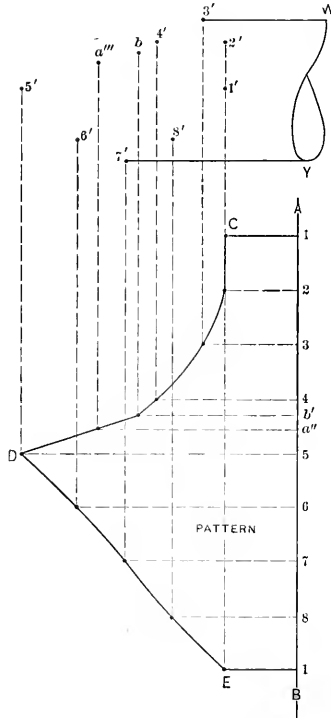

FIG. 37.

FIG. 38. Shows the intersection between a rectangular pipe and elbow, both of which are to be developed full.

PATTERN FOR STATIONARY AWNING

FIG. 39. In this figure ABC represents the elevation of a semi-circular window, on which is to be hung a stationary sheet metal awning, the latter to be constructed of $\frac{1}{4}$ -inch metal. The semi-circle from 4 to 4 is struck from D as center, the sides 4-B and

4-C being straight. *EFG* shows the side view, the distance *FG* being established at pleasure. Having the front and side in their proper position, divide the profile *BAC*

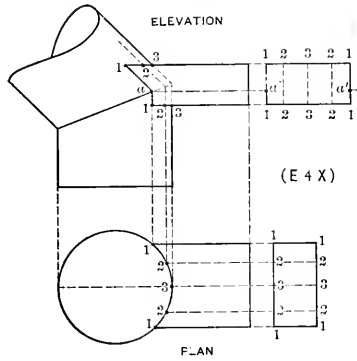

FIG. 38.

into equal spaces as shown, and draw horizontal lines until they intersect *EF*, from which intersections, parallel to *EG*, draw lines indefinitely cutting *FG* as shown. From

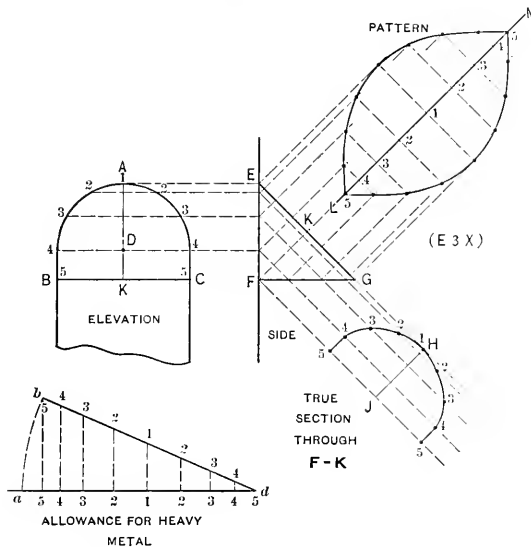

FIG. 39.

any convenient point as *H*, at a right angle to *EG* draw *Hf*. Now measuring from the line *AK* in elevation, take the various distances to points 1 to 5 and place them on lines

having similar numbers, measuring on either side of the line Hf . A line traced from 5 to H to 5 will be the true section through FK , from which the stretchout is obtained with which to develop the pattern. As the awning is to be made from $\frac{1}{8}$ -inch metal, allowance for the thickness of the metal must be added to the stretchout, the manner of doing this being explained in connection with Fig. 10. Therefore in Fig. 39 draw any horizontal line as ad , upon which place the stretchout of the true section $5H5$, as shown by similar figures on ad . As seven times the thickness of the metal should be added to the stretchout for a full circle, and as we have but a half circle $4A4$ in elevation, add one-half of seven times $\frac{1}{8}$ -inch or $\frac{7}{16}$ -inch, as is indicated by $5-a$ on the line ad . With d as center and da as radius, draw the arc ab , which intersect by the vertical line drawn from 5. Draw a line from 5 to d , also vertical lines from the points on ad , intersecting bd as shown. Then will the various divisions on bd be the required stretchout, which transfer to line LM drawn at right angle to EG in side view. Measuring lines are now drawn and intersected in the usual manner and as shown in the drawing.

FIG. 40. In this figure, A shows the elevation of a can lip, the plan view of which is cde . A true profile or section must be found through $a-b$. The lip is to be constructed from No. 24 iron, and no allowance is necessary for the thickness of the metal.

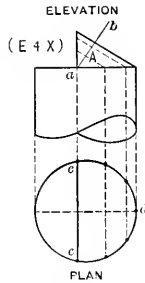

FIG. 40.

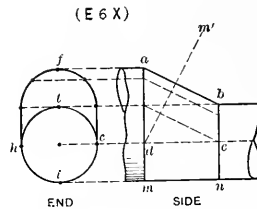

FIG. 41.

FIG. 41. Shows how the parallel line method can be employed for developing the gusset sheet $a-b-cd$, when the horizontal widths through ad and bc are equal. Here $jcil$ is the section through am and $teih$, the section through bn . Prepare the pattern for that portion shown by $abcd$, a true section being required through $m'd$. The gusset sheet is to be constructed from $\frac{1}{8}$ -inch metal, and follow the rule given in Fig. 39.

FIGS. 42 and 43. Are to be constructed from No. 24 metal and no allowance is required for the thickness of the metal. In Fig. 42 BC is the plan of the can struck from A , and 3-4-5-6 the plan of the boss, the section of which on 4-5 is the diameter of the faucet shown at D . The true section is shown at E . The pattern for half of the boss is to be developed, with a seam as shown at top and bottom. Fig. 43 shows the plan

and elevation of a tub with a flaring head, the width at top and bottom being equal. Only the pattern of *abcd* is to be developed.

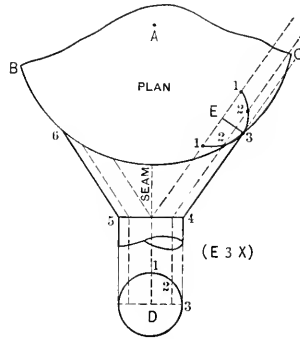

FIG. 42.

PATTERN FOR TWISTED CURVED ELBOW

FIG. 44. Shows the plan and elevation of an elbow curved in both views. The horizontal section through *ij* in elevation is shown by *1''j''1'''* in plan, while the vertical section through *5'''6''* in plan is shown by *5-6-6'-5'* in elevation. The curves in plan and elevation are struck from the centers *Y* and *X* respectively. While a com-

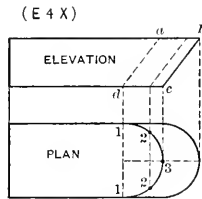

FIG. 43.

pleted elbow of this kind appears like a complicated piece of pattern work, its development is very simple. Having drawn the plan and elevation in their proper positions, either one of the curves in plan or elevation can be divided into equal spaces (in this case the top curve *A*), as shown by the small figures 1 to 6. From these points vertical lines are drawn, intersecting the curves *B*, *C* and *D*, as shown by similar letters and figures. Establish an intermediate point in the curve *B* at *e*, another in the curve *C* at *h*, and one in the curve *D* at *D*. Draw vertical lines through these points into the plan and

elevation as shown. It will be noticed that in place of dividing each curve into equal spaces, only one curve (A) has been so divided, making all the other spaces in the curves B, C and D unequal. This method avoids a confusion of lines, and only necessitates placing each space separately on the various stretchouts as will be explained. Therefore, to obtain the pattern for the top A, draw any horizontal line as EF, upon which place the stretchout of the top curve A, as shown by similar figures on EF. At a right

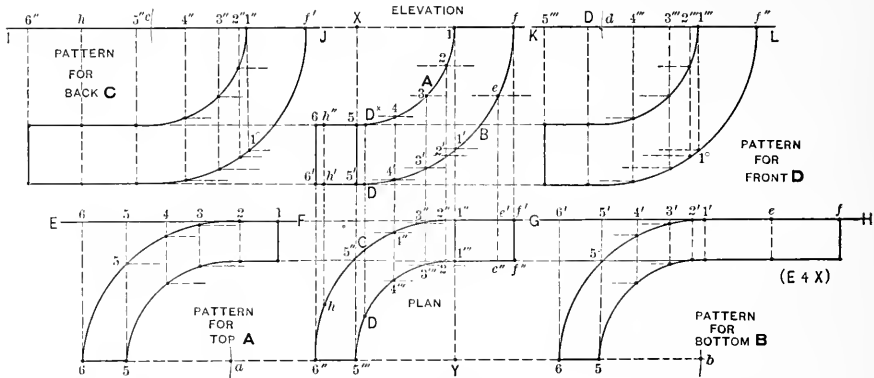

FIG. 44.

angle to EF, through the small figures, draw the usual measuring lines, which intersect by horizontal lines drawn from similar numbers in the plan, resulting in the pattern for top A. The portion shown by 5-6-5° is a reproduction of 5"-6"-5" in plan, and is obtained by using 6"Y as radius, and then with 6 in the pattern for top as center, intersecting the line 6Y' at a. Using the same radius, with a as center, draw the arc 6-5°. In precisely the same manner the pattern for the bottom B is obtained. Measure the various spaces in the curve B and place them on the stretchout line GH. Draw the usual measuring lines and intersect same as before, b being the center from which to draw the arc 6-5°. To obtain the patterns for the back C and front D in plan, take the stretchouts of the curve C and curve D, and place them on the horizontal lines IJ and KL respectively. Draw the usual measuring lines, which intersect by lines drawn from similar numbered intersections in elevation, parallel to the stretchout lines, resulting in the patterns shown. 1''f'1° and 1'''j'1° are reproductions of 1f1' in elevation, the radii c' and d' being obtained from Xf in elevation.

FIG. 45. Shows the plan and elevation of an elbow, the horizontal and vertical sections of which are shown respectively by abcd in plan and abcd in elevation.

PATTERNS FOR FACE MITERS

FIG. 46. Shows the elevation of a panel, the corners of which are broken on the one end, thus forming outside miters at *ab* and *ji*, and an inside miter at *cd*, the other end being circular, struck from the center *A*. The shaded portion indicates the section of the panel mould. It will be noticed that the miter

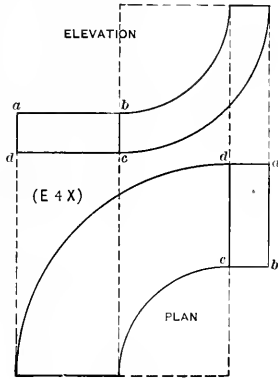

FIG. 45.

ines of the in and outside angles are perfectly straight, as shown by one of the miter lines *ad*, while the miter line between the straight moulding *DE* and curved moulding *Eh* is an irregular line as shown by *EXF*. To obtain the miter line *EF*, take the vertical distances of 2, 3, 4 and 5 in the section, and place them on the horizontal line *BC* as shown by *hfjwc*. Then using *A* as center, draw the various arcs intersecting similar numbered horizontal lines as shown. For the pattern for *DEFG*, place upon the stretchout line *∫H*, the stretchout of the mould 1 to 6 as shown. Draw the measuring lines at right angle to *∫H*, which intersect by lines drawn at right angle to *DE* from similar points on the miter lines *DG* and *FE*, resulting in the pattern shape *LMNO*. *OL* is the outside miter for the exterior angles shown in elevation, while the reverse of *OL* or the cut belonging to the dotted lines is the inside miter for the interior angles. Take the distance of *ic* or *ca*; or *jd* or *db*, and place it as shown by *OP* and *LR* and draw from *P* to *R* a duplicate of the cut *OL*. Then *OPRL* is the pattern for *icdj* or *cabd*. To get the pattern for *mniij*, take one-half of *mj* and place it as shown from *R* to *S* and draw the vertical line *ST*. Then *TPRS* is the half pattern. The patterns for the circular mould will be explained in Part Two.

FIGS. 47, 48, 49 and 50. In Fig. 47 the patterns for *a* and *b* are to be developed. In Fig. 48 a triangular raised panel is to be drawn, the three sides of which are equal, as shown by the dotted curves. *a-b* is the section through *cd*. The center point *c* is

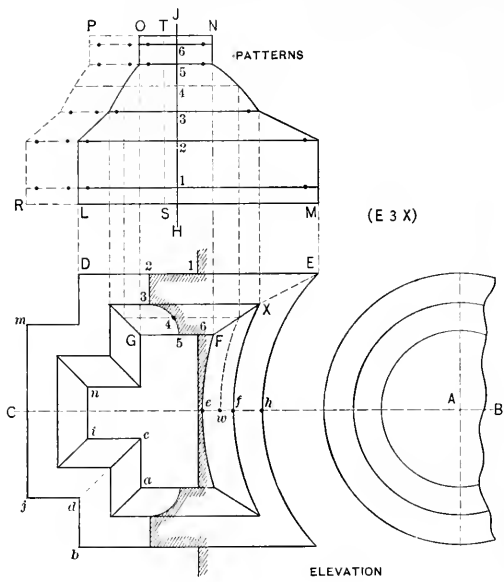

FIG. 46.

obtained by dropping the vertical line *jd* and intersecting it by a line drawn from the apex *h* at right angles to *fi*. All three being alike, the pattern for *e* only is required

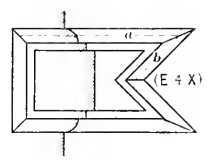

FIG. 47.

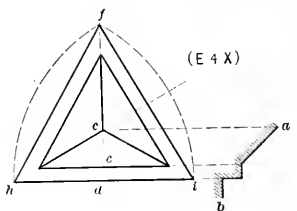

FIG. 48.

Fig. 49 shows another form of face miters in the style of a pediment in a cornice. After the elevation *ABCD* has been drawn, draw the vertical miter line *HI*, and find the miter line *Fγ* by bisecting the angle *AFH* by the line *a-b*. Place the profile *E* in position and

proceed as shown by the dotted lines. Only the pattern for $FHI\tilde{y}$ is to be developed. Fig. 50 is another form of face miter, where a horizontal moulding AD joins a circular moulding BC . The vertical heights on $a-b$ are placed on BC , and with F as center, arcs are drawn as explained in Fig. 46, resulting in the miter line GH in Fig. 50. The pattern for $AGHD$ is to be developed.

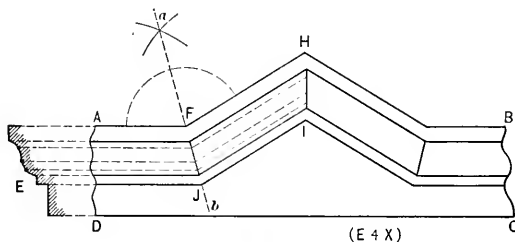

FIG. 49.

PATTERNS FOR RETURN MITERS

FIG. 51. Shows the long and short method of obtaining a square return miter, also for obtaining return miters at any angle. Let A represent the elevation of a moulding, and B the plan of the in and outside miter. The long method of obtaining a square return miter is shown by $EDGF$. The mould A is divided into equal spaces and from

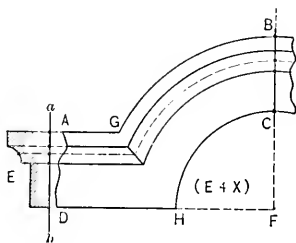

FIG. 50.

the points vertical lines are drawn to the miter line $a-b$ in plan. The stretchout of the mould A is now placed upon the horizontal line ED , from which measuring lines are drawn and intersected by lines drawn from similar points on the miter line ab , parallel to ED . $EDFG$ is the pattern for a square return miter. This same pattern can be obtained without the use of a plan, but the rule can only be employed for square miters, or 90° angles. At right angle to the line of the moulding A erect the stretchout line

LM, upon which the stretchout of the profile *A* is placed. Measuring lines are drawn and intersected as shown, resulting in the pattern shape *LMNO*. Upon comparison, the two patterns will be found alike. Should an inside square miter be required the

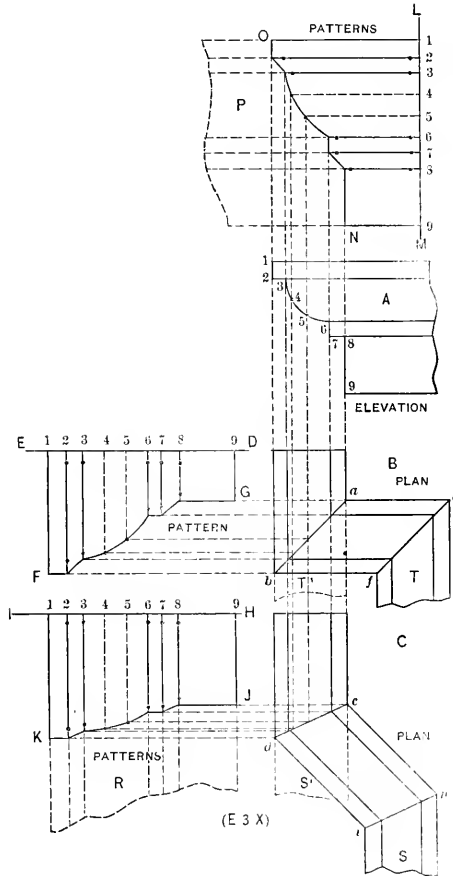

FIG. 51.

opposite cut of the outside miter is used, as shown by the dotted portion *P*. This is self-evident, because if we take that portion shown by *T* in plan, and place the miter line *fe* against the miter line *ab*, it will form one continuous mould, as shown by the dotted portion *T'*.

The principle used for obtaining a square return miter by the long method, can also be applied to getting out patterns for return miters at any angle. Let C be the plan of the mould at any given angle. Find the miter lines cd and hi , and having the profile of the mould in its proper position, it is only necessary to drop lines intersecting the miter line cd , when the pattern is obtained as shown by $HI\tilde{y}K$. For the inside miter hi in plan, the opposite cut of $\tilde{y}K$ in pattern is all that is required, as shown by R , because if ihS is placed on the miter line cd , a straight mould is the result as shown by the dotted part S' . No matter what profile or angle is required, these principles hold good in all cases.

FIG. 52. In this figure, A is the profile of an eave trough, for which square in and outside miter patterns are to be developed by the short rule, placing the patterns above the section. The in and outside miter patterns are also to be obtained for the angle shown by abc in plan.

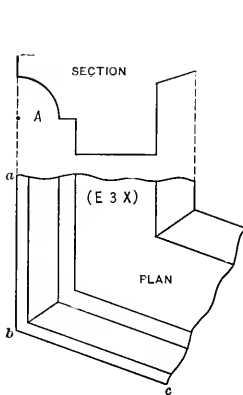

FIG. 52.

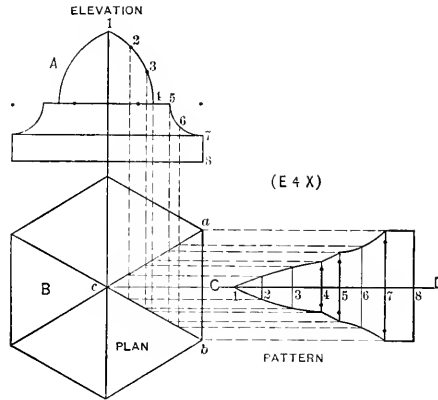

FIG. 53.

PATTERNS FOR ARTICLES WHOSE BASES ARE REGULAR POLYGONS

FIG. 53. The principles explained in the preceding problem are also applicable to regular polygons. In Fig. 53, A shows the elevation of a cap, the plan of which B is a hexagon. Draw the miter lines in plan as shown. Divide the profile in elevation into equal spaces, and extend vertical lines cutting the miter lines ac and bc in plan. At right angle to ab draw the stretchout line CD , and proceed to develop the pattern in the usual manner.

FIGS. 54, 55. The former shows the elevation and plan of a ball to be made in ten sections. In developing a pattern for a ball constructed in gore sections, it is

always best to first draw the plan, making *ba* the semi-diameter of the required ball, and then in line with *ad* construct the elevation. In developing patterns for any article, the bases of which are regular polygons, the student should bear in mind that the true profile must always be placed on a line at right angles to one of the sides in plan as *ad*, and not at right angles to the miter line *ab*. The pattern for one section *abd* is all that is required. Some times it is necessary to make a finished elevation, showing the

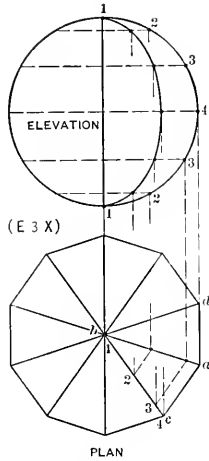

FIG. 54.

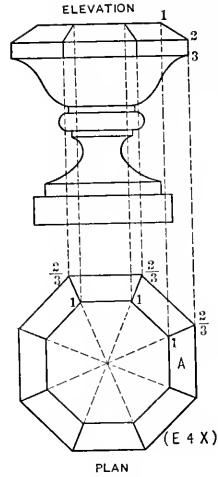

FIG. 55.

miter lines, and while this is not necessary in developing the pattern, the principle will be explained. From the various intersections in the half ball, drop lines to the miter line *ab*, from which points, parallel to *ac*, draw lines intersecting *cb*. From these points lines are erected, intersecting similar horizontal lines in elevation, as shown by the inner curved line. In Fig. 55 is shown an urn, the plan of which is an octagon. Make a finished elevation, showing the miter lines projected from the plan and develop the pattern for side *A*.

PATTERN FOR ELBOW JOINING VERTICAL ROUND PIPE

FIGS. 56, 57, 58 and 59. When pieced elbows are to be joined to round square or rectangular pipes, whether the pipe is in a vertical or horizontal position, or whether the center of the elbow is in line with the center of the pipe, as shown in plan in Fig. 56, or placed to one side, the principles here given are applicable to all. Let *ABCD* represent the elevation of the vertical pipe, *DE* the throat and *DF* the dia-

meter of the elbow. Erect the vertical line EG and with E as center and ED as radius, draw the quadrant DH . As the elbow is to have four pieces, and as each of the middle sections represent two end sections, then divide the quadrant into six equal parts, making Hc and aD each equal to one part, and ab and bc each equal to two parts. From E , through a , b and c , draw the miter lines af , bc and cd and complete the outline of the elbow $DFGH$. Draw the profile of the elbow as shown at \mathfrak{F} , dividing it into equal parts as shown from 1 to 7. In its proper position draw the plan of the

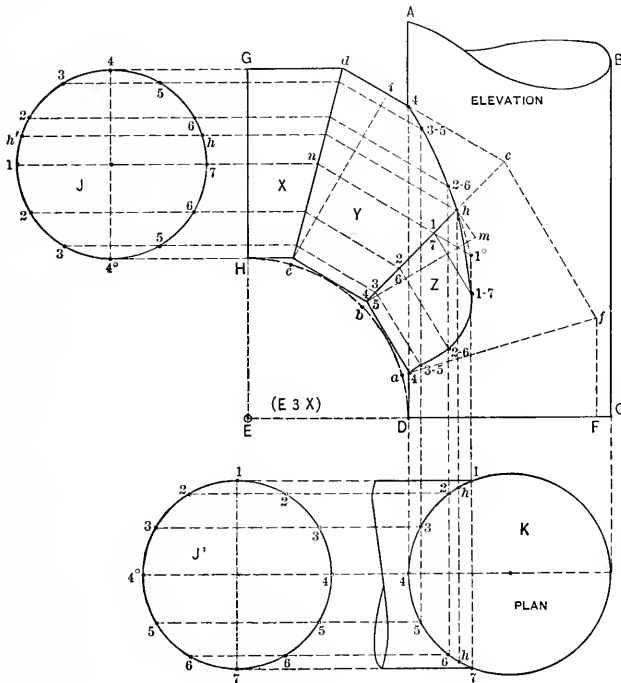

round pipe K . As the center of the elbow is to meet the center of the pipe, place a duplicate of the profile \mathfrak{F} in elevation, as shown by \mathfrak{F}' in plan. If the line $4-4^\circ$ is vertical in elevation, it must show horizontal in plan. Through the small figures in \mathfrak{F}' draw horizontal lines until they intersect the profile K as shown, from which intersections erect lines indefinitely. Through the small figures in the profile \mathfrak{F} in elevation, draw horizontal lines until they intersect the miter line dc , from which points parallel to dc , draw lines intersecting similar numbered vertical lines erected from the

plan, as shown by 4, 3-5 and 2-6, allowing the balance of the lines to intersect the miter line bc as shown. From the intersections on the miter line bc , parallel to cf , draw lines intersecting similar vertical lines drawn from the plan. Through points thus obtained, trace the line in section Y' , as shown from 4 to 3-5 to 2-6; and in section Z , a line from 4 to 3-5 to 2-6 to 1-7. It is evident that a straight line should not be drawn from the intersection 2-6 in section Y' to 1-7 in section Z , it being necessary to first find the point of intersection, where the joint line between the elbow and vertical pipe crosses the miter line bc of the elbow. This point can be found by assuming that the section Y' of the elbow is a straight pipe intersecting the vertical pipe at the angle shown. Therefore, extend the line $u1$ until it intersects the line drawn from 1 in plan at 1° in elevation. Trace a line from 2-6 in section Y' to 1° , which cuts the miter line bc of the elbow at h , giving the desired point. Trace a line from h to 1-7 in section Z . Then $4h4$ is the line of joint between the elbow and pipe. Drop the point h in elevation, into the plan K as shown by h and h' . Also project this point h in elevation parallel to the elbow ad and dG until the intersections h and h' are obtained in the profile \mathcal{Y} . These points will be used in developing the patterns. Notice that the portion of the elbow shown dotted is not required. To obtain the pattern for the opening to be cut in the vertical pipe, take the stretchout of all the spaces contained in 1-4-7 in plan, and place them on the horizontal line AB in Fig. 57, as shown by similar numbers. From these small figures erect vertical lines as shown. Now, meas-

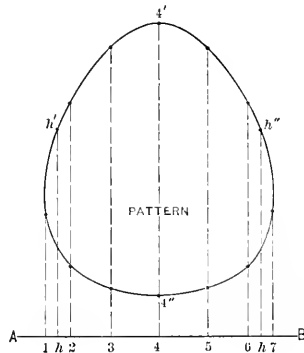

Fig. 57.

uring in each instance from the line DC in elevation in Fig. 56, take the various vertical heights to the intersections 4, 3-5, 2-6, 1-7, h , 2-6, 3-5 and 4, and place them on similar vertical lines in Fig. 57, measuring from the line AB , resulting in the pattern shape, when a line is traced through points thus obtained, as shown by $h'4'h''4''$. The pattern for the section X in Fig. 56 is obtained along the lines previously explained.

To get the pattern for section *Y*, draw any vertical line as *ic* in Fig. 58, upon which place the stretchout of the profile \tilde{y} in Fig. 56. Draw the measuring lines in Fig. 58 at right angles to *ic*. From *c* in Fig. 56 draw the line *ci* at right angle to *dc*. Now, measuring from this line, take the various distances to the various intersections on the miter lines *dc* and *4hb*, and place them on similar lines in Fig. 58, measuring on either

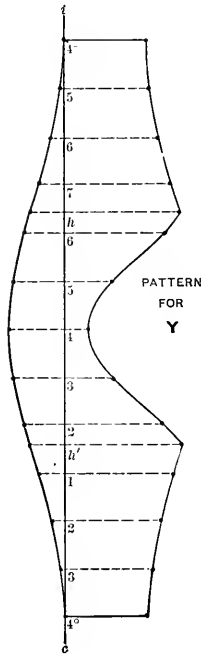

FIG. 58.

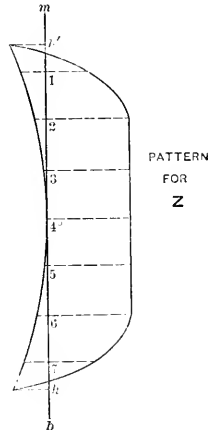

FIG. 59.

side of the line *ic*, giving the pattern shown. As the pattern for section *Z* in Fig. 56 only requires the stretchout of \tilde{y} from *h* to 4° to *h'*, place the stretchout upon the vertical line *mb* in Fig. 59 and obtain the pattern in a manner already explained, measuring from the line *bm* in Fig. 56 to the various intersections on the miter lines *hb* and *ha*.

FIG. 60. Shows the intersection between a four-pieced elbow and rectangular pipe.

Note that the intersection *a* is obtained by drawing a line from *4* to 5° , and the intersection *b*, by drawing a line from *2* to 3° . The intersections *a* and *b* are both projected into the plan and profile in elevation as shown. The patterns are to be developed for sections *A* and *B* of the elbow, and for the opening in the side *C* of the vertical pipe.

PATTERNS FOR REDUCED MITERS

FIG. 61. The principles given in Fig. 61 for obtaining the patterns for a square reduced miter, are applicable to any reduced miter, no matter what shape it may have in either plan or elevation. Let $CDEFGH$ be the plan of the reduced miter.

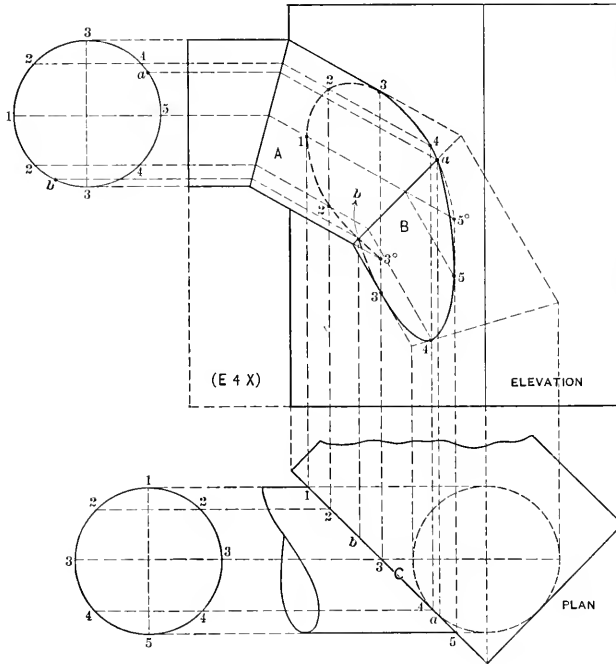

FIG. 60.

The section at right angle to DE is shown by A . Divide this profile into convenient spaces and from these points project lines to the miter line DG , from which vertical lines are erected indefinitely. At right angle to CD from any convenient point as b , draw $b1$. Now, measure the various distances from the line $a1$ in A to points 1 to 7 and place them on similar lines, measuring from $1b$ in the profile B , thus obtaining the profile B , which is the section through HC in plan. It is evident that the height of the moulding remains the same, but the distances in plan EF and HC are unequal. The pattern for $DEFG$ is obtained by placing the stretchout of A on $F\bar{f}$ and proceed-

ing in the usual manner. The pattern for *CDGH* is developed by placing the stretch-out of *B* on *HL*.

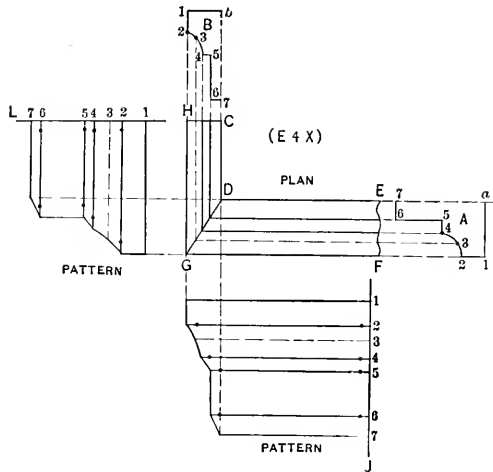

FIG. 61.

FIGS. 62, 63, 64 and 65. In Fig. 62, *A* is the given profile through *a-b*. The angle of the plan is an octagon and the true profile through *C* and the patterns for *B* and *C* are to be developed. Fig. 63 shows the plan and elevation of a cap, the patterns for *A* and *B* to be developed. Fig. 64 shows a moulded base, the bottom of which is an

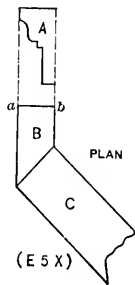

FIG. 62.

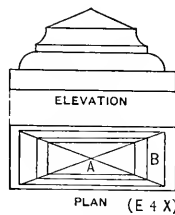

FIG. 63.

octagon and top *abcd* square. Develop the patterns for the side *A* and gore piece *B*; also project the miter line *ef* from plan to elevation. Fig. 65 shows the soffit plan and elevation of the bottom of a bay window. In this problem the profile through *A* is

given and it is necessary to find the true profiles through *B* and *C*, at right angles to their face lines, after which the patterns are to be developed for *A*, *B* and *C*. The miter lines should also be projected from the plan to the elevation, although this is not necessary in the development of the patterns. In practice only one-half of elevation and plan is necessary.

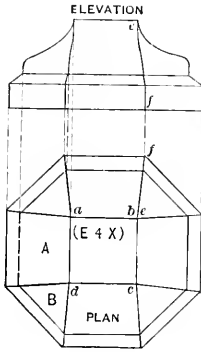

FIG. 64.

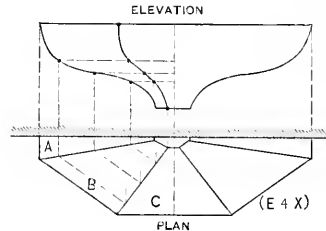

FIG. 65.

PATTERN FOR ROOF DORMER

FIG. 66. Shows the elevation and side view of a roof dormer. The roof or top *DE*, instead of being on a horizontal line, has an incline and butts against the main roof *FE*. If the roof *DE* were horizontal, the problem would present nothing more than a butt miter and the true profile would be shown by the elevation *ABC*. But as the roof *DE* is inclined, a true profile must first be found through *DH* before the pattern can be developed. First draw the elevation *ABC*, using *a*, *b* and *c* as centers from which to strike the arcs *ABC*. Also draw the side view *DEF*, showing the dormer and main roofs at their proper angles, and divide the half elevation *BC* into equal spaces, as shown from 1 to 6. From these points draw horizontal lines, cutting the face of the dormer *DC* in side view from 1 to 6. From these intersections parallel to *DE*, draw lines cutting the main roof line *FE* also from 1 to 6. From *D*, at right angle to *DE*, draw the line *DH* intersecting the various lines drawn from 1 to 6, and extend *DH* until it intersects the line drawn from point 6 parallel to *DE* at *H*. Now, take the various divisions on *DH* and place them on the center line extended in elevation as *D'H'*, from which points, horizontal lines are drawn and intersected by lines drawn at right angles to *AC*, from similar numbered points in the half elevation *BC*. Trace a line through points thus obtained, then *D'H'* will be the half true profile through *DH* in side view. Take a

stretchout of this profile $D'f$, and place it on the line LK , which is drawn at right angles to DE . Through the small figures and at right angles to LK draw the usual measuring lines, which in turn are intersected by lines drawn at right angles to DE , from similar numbered intersections on the roof line EF and the face line CD . MNO then represents the half pattern for the dormer roof. Some times it is necessary to find the shape of the opening to be cut in the main roof. This is accomplished by drawing $F'E'$ parallel to FE and at right angle to FE , from the various intersections, 1 to 6, draw lines indefinitely, crossing $F'E'$ as shown. Then measuring in each instance from the center line Ba in elevation, take the various horizontal distances to points 1 to 6 in BC , and

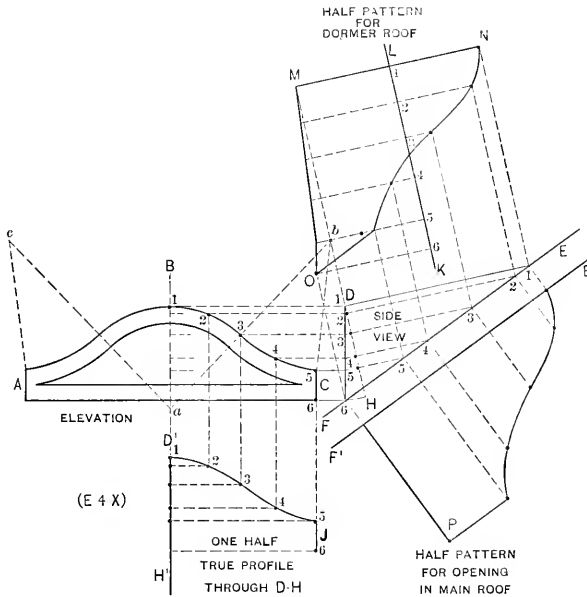

FIG. 66.

place them on similar numbered lines, measuring in each instance from the line $E'F'$. Tracing a line through these points will give the half pattern shape $E'PF'$. No matter what shape the dormer may have, or whether the main roof is inclined or curved, the principles are the same.

FIG. 67. Shows a dormer in which the curves in elevation are struck from the centers a, b and c and the roof having the incline ih . The main roof is curved, the arc de being struck by a given radius. Find the true profile, also the pattern for one-half of dormer roof and half the opening for the main roof.

PATTERNS FOR MITERS BETWEEN MOULDINGS OF DIFFERENT PROFILES

FIGS. 68, 69. When different shaped mouldings are to join together at various angles, either inside or outside miters being desired, the principles illustrated in Fig. 68 should be employed. *A* and *B* represent two different mouldings to be joined together

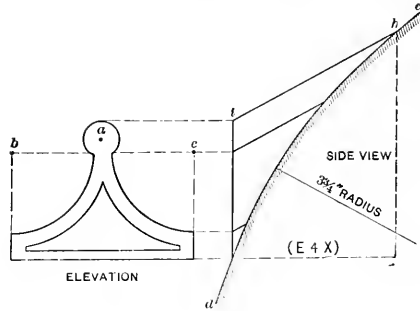

FIG. 67.

at a right angle. Divide either one of the profiles (in this case *A*) into an equal number of spaces as shown by the small figures 1 to 9, from which points horizontal lines are drawn, intersecting the profile *B* from *r'* to *q'*. To obtain the pattern for the mould *A* mitering against the mould *B*, take the stretchout of *A* and place it on the vertical line *BC* as shown. Draw the usual measuring lines to intersect vertical lines drawn from similar intersections in *B*. Trace the pattern line *FG*. In similar manner obtain the pattern for the mould *B*, mitering against the mould *A*. Take the stretchout of *B* (measuring each space separately because they are all unequal) and place the spaces on the vertical line *DE*, as shown by similar numbers. From these points horizontal lines are drawn, which are intersected by vertical lines dropped from the profile *A*. Trace the pattern line *JK*. If the patterns shown by the solid lines were formed up according to their respective profiles and then joined together they would form an interior angle shown by *HEJABC* in Fig. 69. If an exterior angle were desired as shown by *NBLFED* it would only be necessary to take the opposite pattern cuts shown dotted by *H* and *L* in Fig. 68, which would give the desired angle.

FIG. 70. In Fig. 70 is shown the front and side view of a keystone, to which the principles explained in Fig. 68 are applied. The patterns are to be developed for *A* and *B*.

FIG. 71. Shows the intersection between a vertical and inclined moulding in elevation. In this case, before the patterns can be developed, the miter line between the two moulds in elevation must first be obtained and the method is easily traced by re-

ferring to the plan and elevation, the angle $r-a$ being 45° . The profiles in plan and elevation are similar. The pattern for A and the opening to be cut in the mould B are both to be developed.

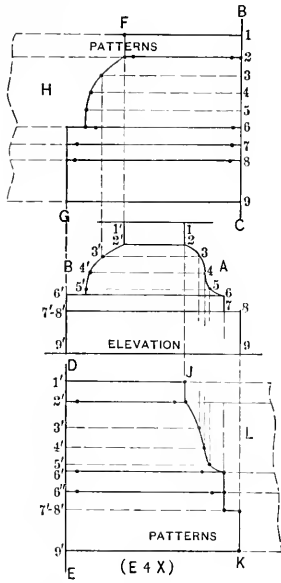

FIG. 68.

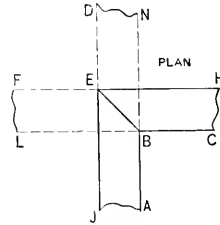

FIG. 69.

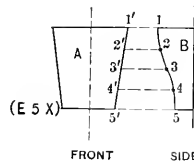

FIG. 70.

FIG. 72. When an inclined moulding, as B in Fig. 72, is to be mitred to the return of the horizontal mould A , at an angle shown by A^2 in plan, then divide either one of the profiles (in this case cd) into an equal number of spaces, and from these points, parallel to ca , lines are drawn intersecting ab . To obtain pattern for the inclined moulding B , the stretchout of $a-b$ is laid out on $a'-b'$ and the intersections in the pattern obtained from cd . For the pattern of the return, shown by A^2 in plan, the stretchout of cd is placed as shown by $c'd'$ and the intersections in the pattern obtained from the projection of the mould ab as shown. A^1 is then the pattern for the return of A , and B^1 the pattern for the inclined mould B .

FIG. 73. When two unequal moulds are to be joined horizontally at other than a right angle in plan, the method shown in Fig. 73 is employed. In this case A and B are the two profiles, one of which (A) must be divided into convenient spaces, shown from 1 to 10, then horizontal lines drawn, intersecting B from $1'$ to $10'$. Draw the

proper angle, whether interior or exterior, as shown by CDE in plan, and place duplicates of the profiles in their proper positions as shown. Parallel lines are drawn in plan intersecting each other from 1° to 10° . The patterns for A' and B' are developed in the usual manner, the stretchout taken from each mould being indicated by similar figures.

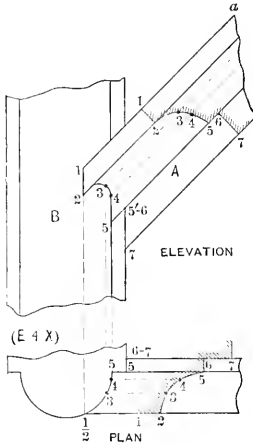

FIG. 71.

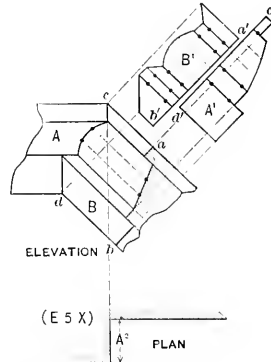

FIG. 72.

PATTERNS FOR VARIOUS BUTT MITERS

FIG. 74. Illustrates the principle applicable to various butt miters, whether the moulding or other object butts against a plain or curved surface in either plan or elevation. Let A represent the profile of the mould in elevation butting against the plain surface BC or curved surface DE , the curved surface being struck by a radius equal to $1\frac{1}{2}$ inches. Divide the profile into equal spaces and draw lines parallel to the lines of the moulding until they intersect BC and DE . The stretchout of A is then laid out on GF , the usual measuring lines drawn, which are intersected by vertical lines drawn from the various intersections on BC and DE . The miter cut $B'C'$ is the pattern for the mould A butting against the plain surface BC in elevation. It will be noticed that where the vertical surfaces $1-2$ and $6-7$ in the profile A , butt against the curved line ED , similar surfaces in the pattern will be reproductions of these curves. To obtain these curves in the pattern take the radius of the curve DE , and with $1'-2'$ and $6'-7'$ in the pattern as centers, draw arcs intersecting each other at a and b respectively. Using the same radius, with a and b as centers, draw the arcs $1'-2'$ and $6'-7'$. Then

FIG. 75. In Fig. 75, *A* shows the profile of a moulding butting against the plain surface *BC* and curved surface *DE*, in plan. Obtain the pattern showing the two cuts.

FIG. 76. Shows the front and side view of a bracket. The drop *A* is to butt against the curve *B*, as shown in side view. The stretchout should be laid off as indicated by *a-b* and the full pattern developed.

FIG. 77. Shows another style of bracket, the pattern for the return around *a, b, c* to be laid out in one piece.

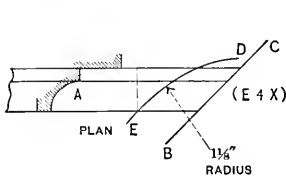

FIG. 75.

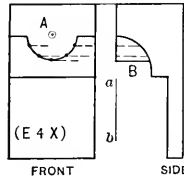

FIG. 76.

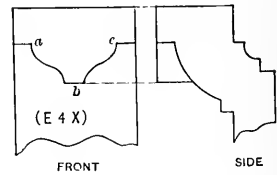

FIG. 77.

FIG. 78. Shows an inclined moulding *A* in elevation, butting against an oblique surface *a-b* in plan. In cases of this kind the miter line *cf* in elevation must first be obtained. This is done by taking a duplicate of the profile in *A* and placing it as shown by *A'* in plan. Lines are projected against the plain surface (or curved surface which ever it may be) *a-b*, from which vertical lines are erected and intersected by similar numbered lines, drawn from the profile in *A*, parallel to the lines of the moulding. The stretchout is then laid off on *cd* drawn at right angle to *A*.

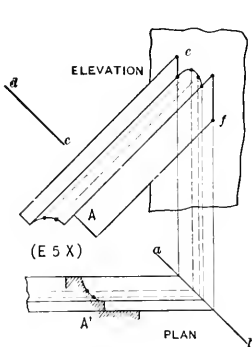

FIG. 78.

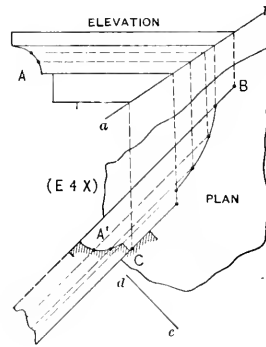

FIG. 79

FIG. 79. Shows another case of a horizontal moulding butting against a plain sur-

face *ab* in elevation, the moulding being placed in an oblique position when viewed in plan. The same operations are gone through as in Fig. 78, the difference being that the position of the mouldings are reversed in Fig. 79. A^1 is a duplicate of *A*, and after the miter line *BC* in plan has been obtained, the stretchout is laid off at a right angle to the lines of the moulding in plan as shown by *de*.

FIG. 80. When a moulding is to butt against a dome or sphere, the work is done as shown in Fig. 80, where the center line *AB* must first be drawn, and with *F* as center draw the one-quarter plan of the dome *DB*. Above this in its proper position, using *E* as center, draw the half elevation of the dome shown by *ACF*. Place the profiles *G* and G^1 in their proper positions in both elevation and plan respectively, and divide each

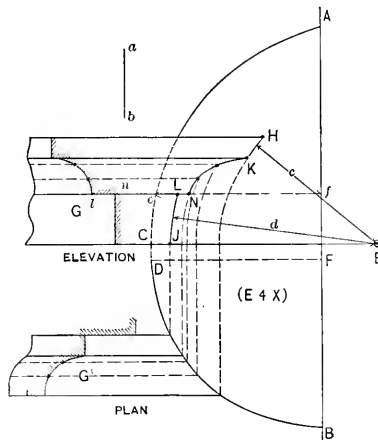

FIG. 80.

into the same number of spaces. From the divisions in G^1 draw horizontal lines until they cut the curve *DB*, from which points, erect vertical lines cutting the base line *CE* of the dome as shown. Now, using *E* as center, with the divisions on the base line as radii, draw arcs, which intersect by lines drawn from similar numbers in the profile *G*, parallel to the lines of the mouldings, giving the miter cut Hj . The stretchout is laid off on the vertical line *ab*. When developing the pattern, the arcs *HK* and Lj are obtained by using as radii the distances *c* and *d* respectively. As that portion of the profile *G* from *l* to *n* cuts the dome on a horizontal plane, the radius with which to strike the arc from *L* to *N* on the pattern is obtained by using the distance through *LN*, shown from *e* to *f*; for it is evident that all horizontal planes are true circles and therefore the plane through *LN* has a radius equal to *ef*.

PATTERN FOR DROP ON A SPHERE

FIG. 81. In making up urns or vases, it is usual to place drops around the sphere or other object to give an ornamental finish. The principle employed in developing the face and return strip is shown in Fig. 81. First draw the center line A_4^8 and using B in elevation as center, draw the semi-sphere CDE . Below the elevation draw a horizontal line as FG , crossing the center line at H . In this case the sphere is to be encircled by a band having four drops. Therefore, from the center H draw the radial lines HI and $H\tilde{J}$ at 45° . Add the projection of the band in elevation shown from E to T , and with BT as radius and H in plan as center, draw the semi-circle G_4^8F , cutting the radial

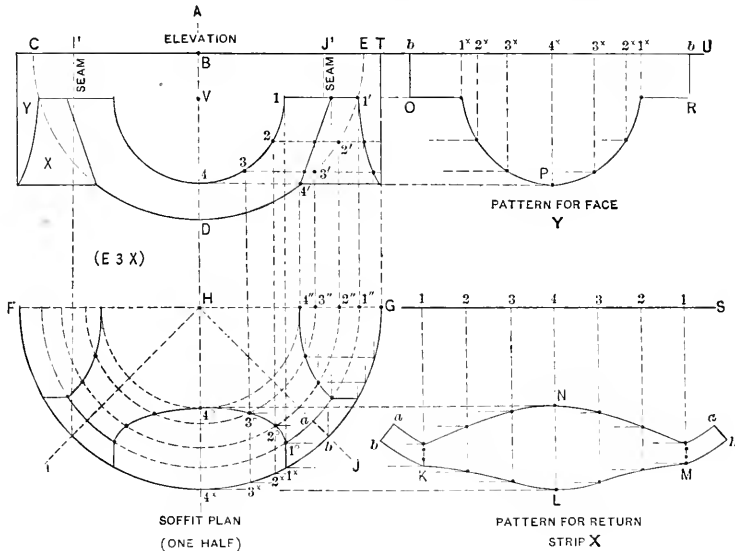

FIG. 81.

lines as shown, and from these intersections extend vertical lines into the elevation as I^1 and \tilde{J}^1 , which lines represent the seam lines. Within the points I^1 and \tilde{J}^1 draw the elevation of the drop as shown, struck from the center V . Divide the quarter circle shown from 1 to 4 , from which points horizontal lines are drawn cutting the sphere ED from $1'$ to $4'$. These horizontal lines then represent planes, the sections of which are true circles and are obtained by projecting vertical lines from points $1'$ to $4'$, cutting the center line FG in plan from $1''$ to $4''$. With H as center and the various points $1''$ to $4''$ as radii, draw semi-circles as shown, which are intersected by vertical lines dropped

from similar numbered points in the elevation V , resulting in the points of intersections in plan 1° to 4° . Extend these lines until they cut the semi-circle GF from 1° to 4° . Then $a-1^{\circ}-4^{\circ}-4^{\circ}-1^{\circ}-b$ represents the half soffit plan of one drop and is all that is required for developing the pattern. Notice that all of one-half of soffit plan has been drawn. This is done in order to show how the complete elevation would appear, when the various intersections in plan have been projected to the elevation. If six or eight or any number of drops were to encircle the sphere, it would only be necessary to divide the plan into the desired number of spaces and obtain the points as shown in this case by 1° and 2° , inside of which the elevation of the drop is drawn. To get pattern for the return strip X in elevation, double the distance 1 to 4 in elevation, and place it on the horizontal line GS , at right angle to which vertical lines are drawn and intersected by horizontal lines drawn from the intersections 4° to 1° and 1° to 4° . Draw a line through points thus obtained, and extend on each side by tracing the bottom of the horizontal band shown in plan by $a-b-1^{\circ}-1^{\circ}$, resulting in $a-b$. Then will $a-b-K-L-M-b-a-N$ be the desired pattern. The pattern for the face is obtained by taking twice the stretchout of the spaces contained in $b-4^{\circ}$ in plan, and placing them on the line TU . Vertical lines are drawn and intersected by horizontal lines drawn from similar numbers in elevation. $bOPRb$ is then the pattern for the face, four such pieces being required to encircle the sphere.

FIG. 82. In this figure $a-b-c$ represents a spun ornament. The plan is a true circle, one half being shown by def . Four drops shown by A will encircle the ornament, the

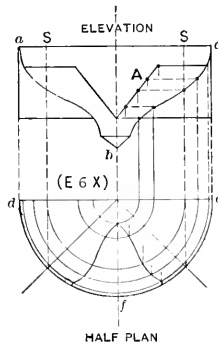

FIG. 82.

location of the seams being shown by $S-S$. Develop the pattern for the face A and its return strip, using the principles given in Fig. 81.

PATTERN FOR INCLINED MOULDING ON A WASH

FIG. 83. The principles used in developing this problem are similar to those given in connection with Figs. 78 and 79, the only difference being in the position of the moulding in Fig. 83. ABC represents the half elevation and $C'D$ the section showing the pitch of the wash. Place the sections or profiles of the mould in their proper positions in both views, as shown by E and E^1 , and divide each into the same number of spaces. From the divisions in the profile E drop lines until they intersect the wash as

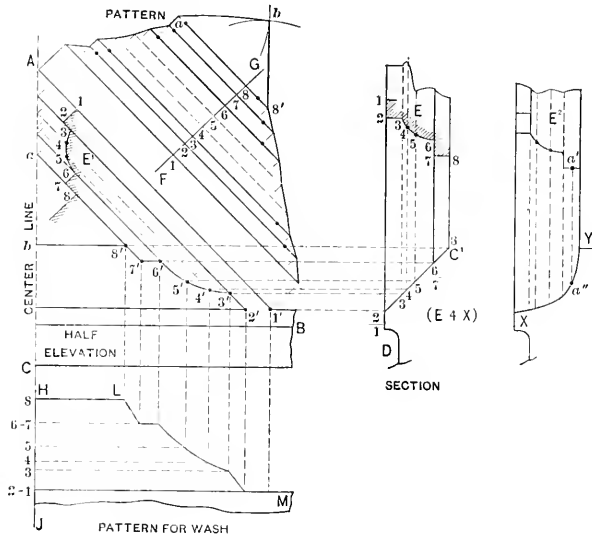

FIG. 83

shown, from which points horizontal lines are drawn in the elevation and intersected by lines drawn parallel to the lines of the inclined moulding, from similar intersections in the profile E^1 . If a line is traced through points thus obtained, it will show the miter line r' to s' . The miter line being obtained, the pattern for the inclined moulding is developed by laying off the stretchout of E or E^1 on FG and intersections obtained in the usual manner as shown. If the triangular piece $a-b-s'$ was to be added to the pattern, then with $s'-b$ and $a-b$ in the elevation as radii, and s' and a in the pattern as centers, describe arcs intersecting each other at b . Draw lines from a to b to s' as shown. To obtain the cut in the wash so as to admit of the mitering of the inclined moulding, take all the divisions contained on the wash in the section and place them on the ver-

tical line $H\tilde{y}$ as shown. Draw the usual measuring lines, which intersect by lines dropped from similar intersections in the miter line $1'$ to $8'$. Then LM is the desired cut.

Applying the method just explained, develop the inclined moulding and wash when the inclined moulding has similar dimensions as shown in Fig. 83, but the wash is curved, as shown from X to Y , the profile E^2 being similar to E . An additional point a' must be used, intersecting the curve at a'' . Why this has been done will become evident when developing the patterns.

PATTERNS FOR RAKED MOULDINGS

FIG. 84. When an inclined moulding is to miter with a horizontal return, whether the plan is a right angle or any given angle, a change in the profile in one or the other of the mouldings is necessary before the patterns can be developed. Hence the term raked moulding. This means a moulding the profile of which is a modification of the normal or given profile. In Fig. 84 let ABC represent the elevation of a pediment, mitring with a horizontal return moulding at top and bottom, at a right angle in plan, as shown by $E\tilde{y}F$. In drawing the elevation, establish the point $7'$ and draw the horizontal line $7'-C$ and the inclined line $7'-7''$. As the inclined moulding is to have the normal or given profile, place this profile D in its proper position as shown. Take a duplicate of D and place it in its proper position in plan as shown by D^1 and complete the plan $F\tilde{y}EHG$.

Divide both D and D^1 into the same number of spaces, and through D parallel to $7'-7''$ draw lines indefinitely. Through D^1 in plan and parallel to $F\tilde{y}$, draw lines intersecting the miter line $\tilde{y}G$, from which intersections erect vertical lines, intersecting the lines previously drawn parallel to $7'-7''$. The result is the miter line and profile B . Parallel to the lines of the inclined moulding, draw $a-b$, perpendicular to which draw lines from the intersections in the profile D , cutting $a-b$ from 1 to 9 . Establish the point $1''$ in elevation, and take the various distances on $a-b$ and place them on the horizontal line $a''-b''$, being careful to have the point 1 come directly over $1''$. From the various intersections on $a''-b''$ drop vertical lines, intersecting similar lines in the inclined moulding, giving the miter line or profile A . When the horizontal moulding returns at a right angle in plan as in this case, the plan is not necessary in obtaining the profile B , but is shown here, to give the principles necessary in obtaining the miter line in elevation when the plan is other than a right angle. The profile or miter line B could be obtained by taking the various divisions on $a-b$, and placing them as shown by $a'-b'$, and intersecting lines as in A . The raked profiles A and B having been obtained, the patterns for the inclined moulding and top and bottom returns are ready to be developed. The pattern for B need not be developed from the plan when the return

is a right angle, but is here shown, to explain the principles which must be used when the plan has an angle other than a right angle. The stretchout of B is placed on KH , the usual measuring lines drawn, and intersected by lines extended from the miter line $\tilde{y}G$; $r'-o$ being equal to HG . B^1 is the pattern for the return B . This rule is applicable for any angle. To obtain the patterns for the right angle returns B and A , without using the plan, apply the method for cutting a square miter. Take the stretchouts of B and A and place them as shown respectively by LM and PR , bearing in mind, that while the normal profile D is divided into equal spaces, the raked profiles B and A have unequal spaces, and each one of these spaces must be carried separately onto their respective stretchout lines. Draw the usual measuring lines, which intersect by vertical lines, dropped from similar points in the profiles B and A . Make the distance NL and PS each equal to HG in plan, or the desired depth of the return. Then B^2 and A^1 represent the patterns for bottom and top returns. The pattern for the inclined moulding is obtained by placing the stretchout of D on the line TU , which is drawn at right angle to the inclined moulding. Measuring lines are drawn and intersected by lines drawn parallel to TU from similar intersections in B and A . The desired pattern is shown by $VWXY$ or D^1 .

FIGS. 85, 86 and 87. Raked mouldings are frequently met with in cornice work and in order that the student shall have ample practice in developing this class of patterns, a number of such problems are given. The first problem to be drawn is a pediment having an outline similar to $hijk$ in Fig. 84, but the return of which has an angle shown by cde in plan. The miter line dj is obtained as shown. The normal profile is to be placed in the inclined moulding as shown by D , and the upper return is to return at right angle in plan. It will not be necessary to develop the upper return as this was done in the preceding problem, and therefore the elevation can be broken on the line ZZ . As the given profile is in the inclined moulding, a duplicate of same must be placed on the line dc in plan, and the miter line projected in the elevation in exactly the same way as in the right angle return. The patterns for the lower part of the inclined moulding and the horizontal return cd in plan are to be developed. The second problem is to use the same elevation as before, but place the normal or given profile at the foot of the gable as at D in Fig. 85, and obtain the raked profiles of the inclined and upper mouldings, also the patterns for the lower, inclined and upper mouldings when the plan is a right angle, in which case no plan is necessary as previously explained. The third problem is to have the same elevation as in Fig. 84, with the normal profile in the horizontal return as shown at D° in Fig. 84, but this return to have an angle as shown by cde in plan. As the horizontal return has the normal or given profile, a duplicate of D° must be placed on the horizontal return cd in plan and the miter line in elevation projected as before. In this problem the patterns for the upper return, and the inclined and lower return mouldings are to be developed, after the raked profiles of the inclined moulding and upper return are obtained. The fourth problem

is given in Fig. 86, which shows a curved moulding, joining a horizontal moulding at right angle hij in plan, D being the normal profile. The same principles are employed

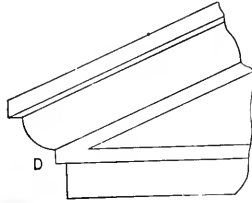

FIG. 85.

as in Fig. 84, with the exception that concentric curves are drawn in elevation, using c as center in Fig. 86. The raked profile D^1 for the curved moulding is obtained by drawing lines at right angles to cd and these lines are intersected from divisions on $a'b'$, which are obtained from the line $a-b$. Obtain the pattern for the right angle return hi in plan, without using the plan view. The method of developing the pattern for the curved moulding will be explained in Part Two. The fifth problem is to develop the pattern for the horizontal return joining a curved moulding at an angle shown by

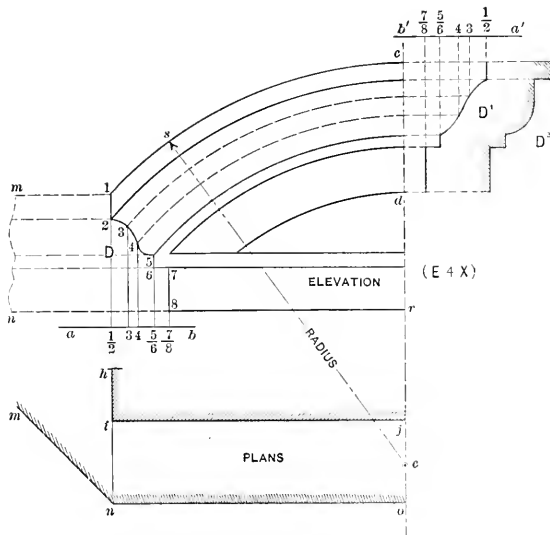

FIG. 86.

mno. In this case the plan must be used, and as the normal profile is given in the horizontal return, a duplicate of D must be placed on line with $m-n$ in plan and elevation and the miter line obtained in elevation. From these intersections concentric curves are drawn and the raked profile D^1 obtained as before. The sixth problem is to obtain the raked profile and pattern for a horizontal return when the normal profile is given in the curved moulding as at D^2 and the plan is a right angle. In this case the profile D^2 must be divided into equal spaces, from which points perpendicular lines are drawn to the center line. Then using e as center, concentric curves are drawn, and in turn, intersected by lines erected from $a-b$ on which the projections of the various spaces in D^2 are placed. Should the circle be of such size that the center line ce could not be used, then any radial line as se can be taken, on which to project the divisions in D^2 , bearing in mind that the profile D^2 must always be placed at right angle to the radial line. The seventh problem is to obtain the raked profile and pattern for the horizontal return when the normal profile is in the curved moulding and the angle is an octagon as shown by $m-n-o$. As the given profile is in the curved moulding, a duplicate of D^2 must be placed in line with $n-o$ in plan, and the miter line projected to the elevation, as previously explained. From the intersections obtained in elevation, horizontal lines are drawn and intersected from projections obtained from the profile D^2 , giving the raked profile from which the stretchout is obtained and used to develop the pattern for the return at right angles to $m-n$ in plan. The eighth problem is given in Fig. 87, and shows the principles used when any number of gables are to be joined together at any angle in plan. Part of the front elevation of a gable is shown, four of which are to be joined at right angles in plan. A is the given profile and is duplicated at A^1 in plan, the miter line cd in elevation being obtained as shown. In both, Figs. 84 and 87, the plan is not required as the gables join at a right angle, but is now shown to explain the principles which apply when the angle is other than a right angle. Without using the right angle plan, all that is necessary, is to obtain the projection from A on the line ab and place the divisions as shown by $a'b'$ and obtain cd . Solve this problem without using a plan and develop the pattern for the gable moulding ic , and add to the pattern the roof of the gable, by placing the distance of the ridge line ih at right angle to the line of the pattern ic and draw a line from h to c in the pattern. The ninth problem is to draw an elevation similar to that shown by the front elevation in Fig. 87, eight gables of which are to join at octagon angles in plan as shown. When drawing this problem, complete a quarter plan of the eight gables through ih in elevation, similar to that shown in the reduced diagram \tilde{y} , showing the ridge and valley lines. A being the given profile, place a tracing of same in the octagon plan at A^2 and proceed to obtain the miter line in elevation. Develop the pattern for the gable mould; the plan of which is an octagon, and add the roof to same by placing the length of the ridge line $m-n$ in diagram \tilde{y} , at a right angle to the line of the pattern—corresponding to ic , and drawing a line or valley line h to c in the

pattern. The tenth problem explains the principles to use when gables are to be joined and when the sides are of unequal widths. In this problem four gables are to be joined, the front and side of which are equal to that shown in Fig. 87, the given profile being shown at *A* and the modified or raked profile at *B* in side elevation. Should the given profile be placed in the side elevation, the raked profile in the front would

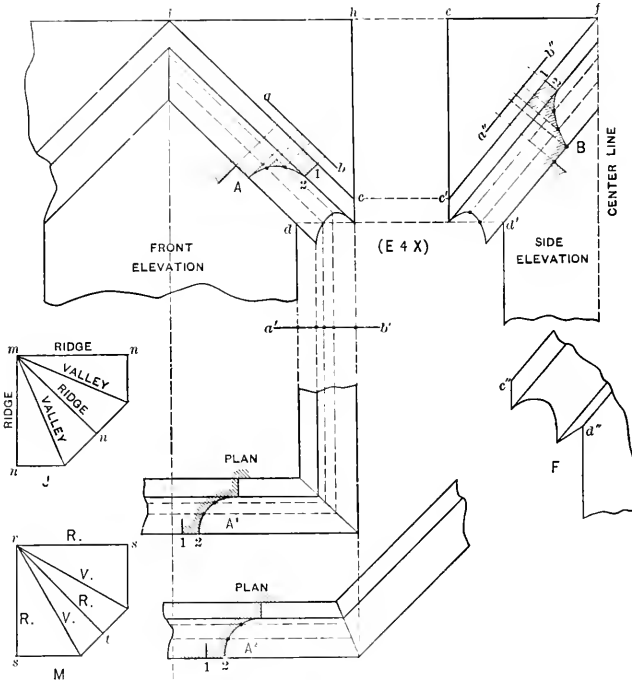

FIG. 87.

be obtained in precisely the same manner as that which will follow. The miter line *cd* being obtained as before, a horizontal line is drawn from *d*, meeting the vertical line in side elevation at *d'*. A duplicate of *cd* is placed in position as shown by *c'd'*. The center line in the side elevation is now established and a line drawn from *i* in front view, intersecting this center line at *j*. Draw a line from *j* to *c'*. Draw lines parallel to *c'j* as shown and place the divisions of *ab* on *a''b''* and obtain the raked profile *B*. As the pitch in the front elevation is less than that of the side, it will be found when drawing this problem to enlarged size, that a double line will show as at *d''* in diagram

F, while a single line shows in side elevation, owing to the small size of the drawing. Why this double line appears will become evident when solving the problem. Obtain the pattern of the front gable by taking the stretchout of *A* and placing it at right angle to *ic*, and add the roof to this pattern by taking the distance of the ridge line *cf* in side, and placing it at a right angle to the line in the pattern, corresponding to *ic* in front. For the pattern of the side gable, use the stretchout of the raked profile *B*, and when adding the roof to the pattern take the distance of the ridge line *hi* in front. The eleventh problem is to obtain the patterns for eight gables, joining at octagon angles in plan, each alternate side being different in width, similar to that shown in diagram *M*. Let the front elevation in Fig. 87 represent one of the wide sides, and the side elevation, one-half of one of the narrow sides, the given or normal profile to be placed in the wide side, as at *A*. Draw a quarter plan of the gables below the front elevation, through *ih* in elevation, showing the ridge and valley lines in plan, from which the true lengths of the ridge lines can be obtained, as shown reduced in diagram *M*, in which *rs* shows the ridge line for the wide side, and *rt* the length for the narrow side. Place a duplicate of the normal profile *A* in the quarter plan just drawn, in the position shown by *A*² in plan, and obtain the miter line *cd* in elevation in the same manner as in the square gable. Transfer *cd* to the side view and obtain the raked profile *B*. What has been said about the double line in *F* is also applicable to this problem.

When laying out the pattern for the wide side, use the stretchout of *A* and add the roof pattern by placing the length of the ridge for the wide side *rs* in *M*, as explained in connection with the square gable. For the pattern of the narrow side, use the stretchout of *B*, and for the roof pattern add the length of the ridge *rt* in *M*. Should the normal profile be placed in side view, the raked profile in front would be obtained by reversing the operations.

PATTERN FOR GUSSET PIECE

FIG. 88. When two pipes of unequal diameters intersect each other, and a gusset piece is required to strengthen the joint or intersection, the principles to be employed (whether the smaller pipe joins the larger at right angles or not) are shown in Fig. 88. *A* is the end view of the large pipe, and *B* the side view, *C* and *C*¹ representing the sections of the smaller pipe. Establish at the desired distances the height and projection γ' and γ'' of the gusset piece, and draw a line from γ' to γ'' . Divide the circles *C* and *C*¹ into equal spaces as shown, being careful to place the vertical line 1-7 in *C* in a horizontal position in *C*¹. Drop vertical lines from *C* to *A*, from which points horizontal lines are drawn and intersected by vertical lines, dropped from similar numbered intersections in *C*¹ from 1 to 4, and resulting in the miter line *b-4'*. From 4' draw a line to γ' , and from the intersections 4 to 7 in *C*¹, drop vertical lines cutting

the miter line $4'-7'$ as shown. From the various intersections on $4'-7'$, draw lines parallel to $7'-7''$ indefinitely, intersecting similar horizontal lines previously drawn from A and resulting in the points of intersections $5''$ and $6''$. $7'-4'$ is then the line of joint between the gusset piece and small pipe, and $4'-7''$ the joint line between the gusset and large pipe. A true profile must now be obtained of the gusset piece, at right angle to $7'-7''$ or through the line $a-4'$, and is obtained by taking a tracing of $4-7-4$ in C^1 and placing it in the position shown by C^2 . Perpendicular lines are drawn, as shown, intersecting similar lines previously drawn. Then $4^0-7^0-4^0$ is the true profile through $a-4'$.

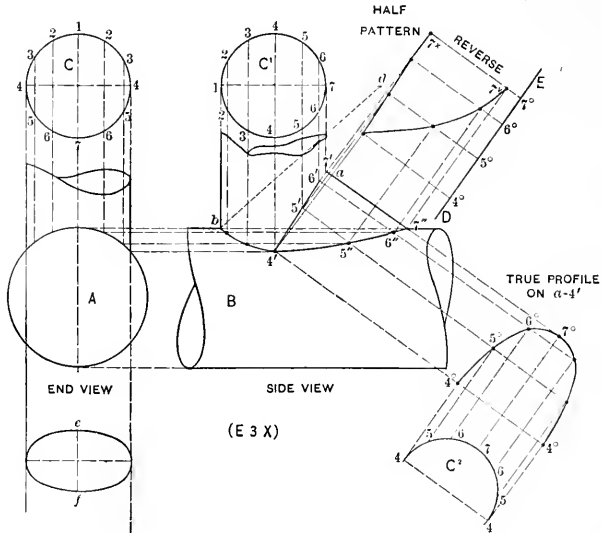

FIG. 88.

Take a stretchout of this profile and place it on the line DE drawn at right angles to $7'-7''$. Draw the usual measuring lines, which intersect by lines drawn at a right angle to $7'-7''$ from similar numbered intersections on $7'-4'$ and $4'-7''$. It will be noted that the half pattern is shown, the full pattern being required and is obtained by reversing on the line 7^*7^* . Obtain the true profile and pattern for a gusset piece, to be placed between the pipes forming an acute angle, when the profile of the small pipe is to be an ellipse as shown in end view Fig. 88, and the angle of the small pipe is to be similar to the dotted line db in front view. In this case the minor axis of the ellipse ef must be placed at a right angle to the line of the pipe bd in front view, the ellipse to be drawn by the method given in Fig. 8.

PATTERN FOR PANELED LEADER OFFSET

FIG. 89. Occasionally a leader or conductor passes down the interior angle of a wall and makes an offset over a wash or other object as shown in Fig. 89. CD represents the wash over which the leader is to pass, but at an angle shown by AB in plan. In this case it is desired that the miter lines appear in the elevation as shown by $1e$ and $1k$, the lines through 1 and e and 1 and k to show horizontal lines when viewed from the front. Draw the plan of the wash CD , as shown by AB , and place the sections of the leader in position as shown by A and B and connect similar corners as shown. Project the elevation of the pipe and draw the section of the panel heads as shown by $cdefh$ and $ijkmn$. Having drawn the plan and elevation, the pattern for the vertical pipe C is obtained by taking a tracing of that part and placing it as shown by C° , at right angle to which the stretchout line $c'd'$ is drawn. On this line the stretchout of either A or B in plan is placed and the pattern obtained in the usual manner. The opposite of the pattern for C° will answer for the pattern for the lower pipe D . To obtain the pattern for the middle section of the elbow, an oblique view must be drawn as follows: Parallel to $1-1$ in plan and of equal length draw the line $1'b'$. From 1 in elevation draw the horizontal line $1-b$, cutting the line projected from $\frac{1}{2}$. Take the height $b \frac{1}{2}$ and place it on the line $1-b'$ extended in the oblique view, as shown from b' to 1° . Draw a line from 1° to $1'$, which is the true length of the pipe on $1-1$ in plan. From the various intersections 1 to 8 in the section A at right angle to $1-1$ draw lines indefinitely, as shown. Measuring from the line $b1$ in elevation, take the various distances to points 1 to 8 on the miter line $\frac{1}{2}e$, and place them on similar numbered lines in the oblique view, measuring in each instance from the line $b'1'$, and resulting in the miter line 1° to 8° . Parallel to $1^\circ-1'$ from these intersections draw lines as shown. The next step is to obtain the true profile of this oblique view by extending the lines just drawn, at a right angle to which draw the line LM . From any point as a in plan, draw the perpendicular aR , crossing the lines shown. As a is placed upon the line $8-8$ in plan, then the intersection of the line LM with the line drawn from 8° in the oblique view as shown by $8'$, will represent similar point. Now take the various distances from a in plan to lines $7-6-5-4-3-2$ and 1 and place them in the oblique view, on similar numbered lines measuring from the line LM . Then E is the true profile for the middle section of the pipe. The stretchout of E is now placed on a line drawn at a right angle to $7^\circ F$ and the pattern obtained as shown. G then represents the pattern for the upper part of the middle section of the elbow, and H the pattern for the lower miter. The patterns for the panel heads are obtained as follows: Where the points $cdefh$, and $ijkmn$ in elevation touch the various bends, project same into the plan intersecting similar numbered

bends, as shown by the small dots. Now take the stretchouts of *cdefh* and *ijkmn* and place them at right angles to *A* and *B*, respectively in plan, as shown by similar letters. Draw the usual measuring lines, which are intersected by lines drawn from similar points of intersections shown by the dotted lines. Then will *N* be the pattern for the panel head shown by *ch* in elevation, and *O* the pattern for the head shown by *i-k-n* in elevation. If it were not necessary for the lines through $\frac{1}{2}$ and *e* in elevation to be horizontal

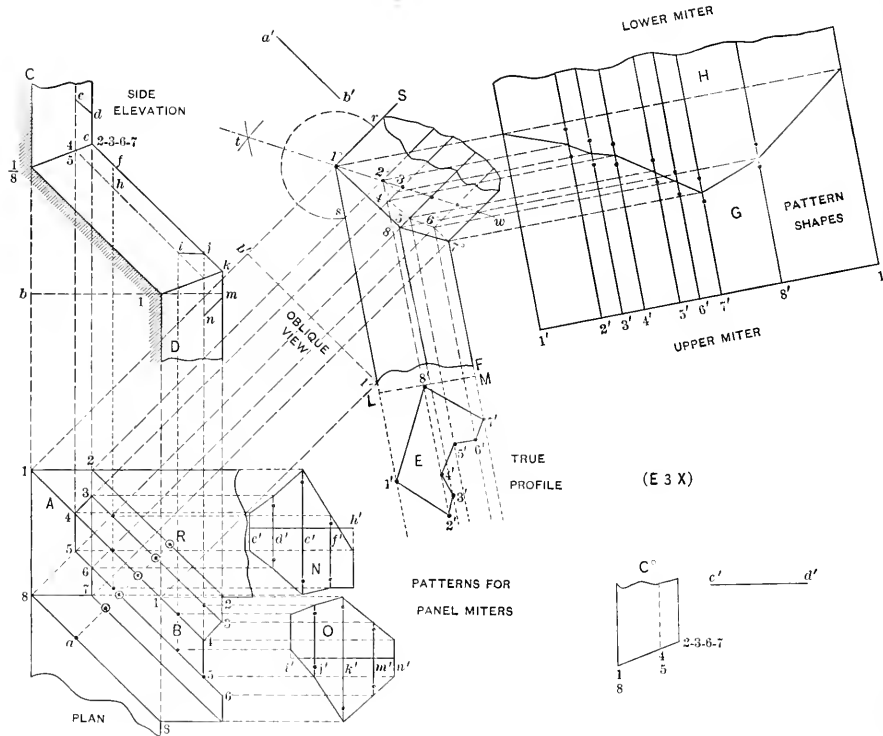

FIG. 89.

lines, when viewed from the front, the patterns for this elbow could be developed by using the same profile *A* or *B* throughout the entire elbow without any change of profile, but the miter line would pass through the diagonal line of the pipe. Further practice in this principle is given in the next problem.

Develop the patterns for an elbow similar to that shown in Fig. 89, using the profiles *A* or *B* throughout the entire pipe. In this case it is only necessary to construct the

oblique view $1^{\circ}-1'-b'$ as before, then bisect the angle $S1^{\circ}1'$ by means of the arc rs and intersecting arcs t and draw the miter line $t1^{\circ}-w$. The intersections 1 to 8 in A are then projected until they cut the miter line tw as shown. The stretchout of A is now placed at right angle to $1^{\circ}S$, as shown by $a'b'$, and the pattern obtained the same as in ordinary elbow work. This one pattern then answers for all of the cuts for the entire elbow. While this is a simple rule it can only be used when the miter line runs through the diagonal of the pipe.

PATTERNS FOR A RAKING BRACKET

FIG. 90. Shows the method of developing the face and side of a raking bracket. The normal side is shown by C , and the normal face of the drop is shown by D . First draw the rake which the moulding is to have, as shown by AB . Place in its proper position the side of the normal bracket C drawn at a right angle to the rake; draw the face of the drop D and also the side of the cap \mathcal{F} . In enlarging this drawing, more spaces should be employed then here shown. Establish at pleasure the point E and draw the vertical line EF . Divide the normal face D , also the circle in same, into equal spaces, and draw lines parallel to the rake as shown. Now take a tracing of D and place it as shown by D^1 , so that the side Z will be in line with $E-F$. From the various points in D^1 erect vertical lines intersecting similar lines drawn from D . A line traced through points thus obtained, as shown by G , 1, 2, 3, 4, 5, 6, 7 and F will be the raked face of drop. Extend $G-1$ to H . For the pattern of the return strip of drop D^2 , take the stretchout of 1-7 in D^2 and place it on the line 6- V extended in the normal bracket as shown by $a-b$. Draw the usual measuring lines which intersect by lines drawn at right angle to the rake from similar intersections on the curve 8-13, resulting in the pattern shown. For the pattern of the lower face of the bracket, divide the normal side into equal parts shown from 8 to 13, from which points lines are drawn parallel to the rake, intersecting the sides of the raking bracket GH and EF as shown. At a right angle to HE draw the stretchout line cd , upon which place the stretchout of 8-13 in the normal bracket. Draw lines at right angle to cd , which intersect by lines drawn from similar intersections on GH and FE at right angles to HE , resulting in the pattern shown. From these same intersections on one of the sides of the raking bracket as FE and at right angle to it, draw horizontal lines as shown, crossing the vertical line $m'n'$ previously drawn. Now measuring in each instance from the line mn in the normal side, take the various distances to points 6, 7, 8 to 13 and place them on similar lines, measuring in each case from the line $m'n'$. A line traced through these intersections will be the pattern for the side of the raking bracket. Divide the normal profile of the cap \mathcal{F} into equal spaces shown from 1 to 6, from which points draw lines parallel to the rake indefinitely. Take a tracing of \mathcal{F} and place it on either side of the raking bracket as shown by \mathcal{F}^1 . From the various intersections in \mathcal{F}^1 , erect lines intersecting similar lines drawn from \mathcal{F} . K then represents the profile of the upper return and L the profile of the lower return. To get the pattern for the cap face of the raking bracket, take the stretchout of \mathcal{F} in the normal side and place it at right angle to the rake as shown by cf , the measuring lines being intersected by lines drawn from similar points in L and K . For the patterns of the returns K and L , take the stretchout of each and place them on the line mn extended, as shown respectively by ih and hj . Draw the usual measuring lines which are intersected by lines drawn parallel to mn , from similar numbers in the profiles \mathcal{F} and \mathcal{F}^1 .

resulting in the patterns for the returns *K* and *L*. Using the same principles given in Fig. 90, develop the patterns for the drop, face and side, when the normal face and side is to be as shown by *Y* and *X*. In this case, the only points necessary to develop the raked face of drop *T* are shown by the small dots. The patterns for the cap need not be laid out.

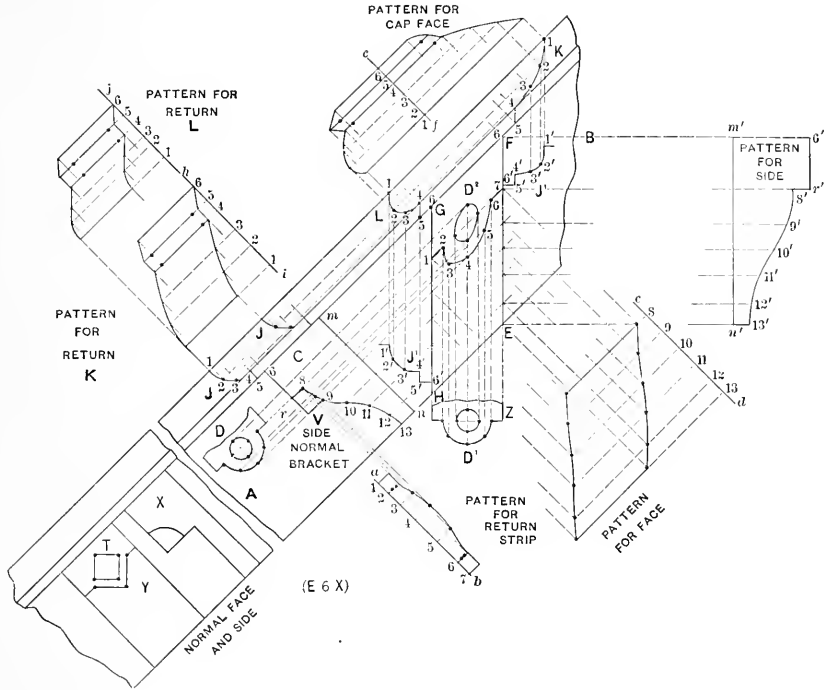

FIG. 90

PATTERNS FOR A RAKING OCTAGONAL BALUSTER CAP

FIG. 91. Shows the method of obtaining the various patterns for a raking octagonal baluster cap. The same principles can be used, no matter how many corners the plan may have or whether the plan has interior or exterior angles; it also being immaterial what pitch the mould may have in elevation. Let *ABCDEF* represent the half plan. Place the normal profile on *CD* as shown by *H*, which divide into equal spaces as shown

and complete the plan $a-b-c-d$. Draw the miter lines Ea , Db , Cc and Bd . Draw the elevation of the body of the baluster as shown by $LI\tilde{J}K$. Take a tracing of H in plan and place it as shown by H' in elevation which represents the given and true profile for the middle part of the baluster. Through the various intersections in H' draw lines parallel to LK , which intersect by vertical lines erected from similar intersections on the miter lines Ea , Db , Cc and Bd and resulting respectively in the miter lines M , N , O and

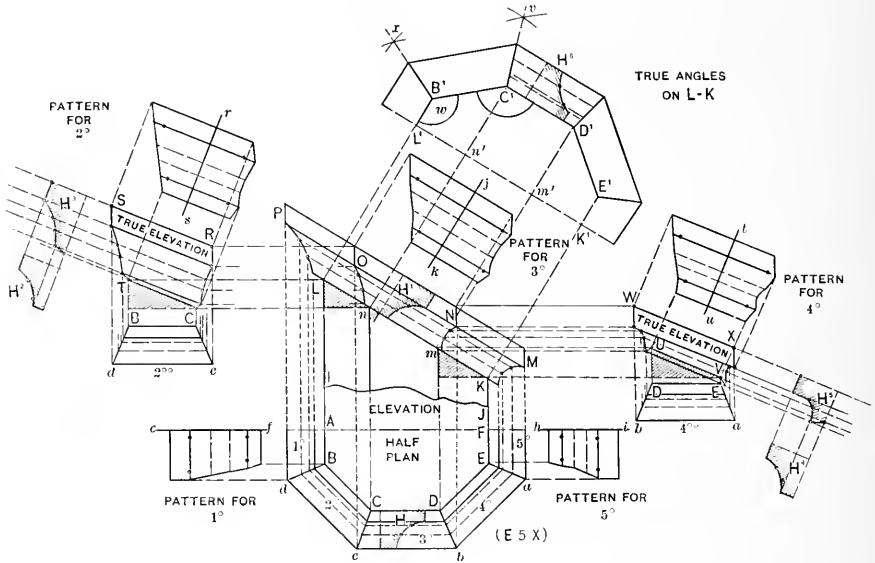

FIG. 91.

P in elevation. The intersections have not been numbered, but by following the dotted lines, the points of intersection are made clear. The various sides of the mould have been marked in plan 1° to 5° . For the pattern 3° , take the stretchout of H' in elevation and place it as shown by kj . Draw the usual measuring lines, which intersect by lines drawn at a right angle to LK from similar intersections in the miter lines N and O . To get the patterns for 1° and 5° in plan, take the stretchouts of PL and KM and place them as shown respectively by cf and hi in plan, and obtain the patterns from intersections on the miter lines Bd and Ea as shown.

Before the patterns for 2° and 4° can be developed, true elevations and profiles must be obtained. Take a tracing of 2° and place it in the horizontal position shown by 2^{00} .

From the various intersections on Cc in 2° , erect vertical lines, which are intersected by horizontal lines drawn from similar points in the miter line On in elevation, resulting in the miter line RC in the true elevation. From L in elevation, draw the horizontal line, which intersect by the vertical line erected from B in 2° . Draw the line TC which represents the true pitch. Parallel to TC from the various intersections in CR , draw lines indefinitely which are intersected by vertical lines, erected from Bd in 2° , and resulting in the miter line ST . $STCR$ is then the true elevation of the side 2° in plan. A true profile must now be obtained by placing a tracing of the normal profile H in plan, as shown by H^2 , and drawing perpendiculars, resulting in the true profile H^3 . Take a stretchout of H^3 and place it as shown on rs and obtain the pattern for 2° as shown by the dotted lines. In precisely the same manner obtain the true elevation and profile for 4° in plan, as shown respectively by $WVVU$ and H^5 . The stretchout of H^5 is placed on tu and the pattern obtained as shown. It should be understood that when the position of all the members as P , O , N and M are vertical the pattern for each side must be obtained as explained. When, however, a given profile can be used throughout the entire pitch, so that the members will stand at right angles to the rake, the method to be employed is as follows: At a right angle to LK from L , n , m and K draw lines indefinitely as shown. Parallel to LK draw $L'K'$. Measuring from the line AF in plan, take the various distances to B , C , D and E , and place them on similar lines, measuring from the line $L'K'$ and obtain B' , C' , D' and E' , which will represent the true half section and angles on LK . Assuming that the profile H in plan is to be used, it is only necessary to place same as shown by H^6 after the miter lines $x-w$ and $v-C'$ have been obtained. The patterns are then developed in the usual manner.

FIG. 92. Applying the principles explained in preceding problem, develop the patterns for an eave and gable moulding, having a pitch equal to $F5$ in elevation in Fig. 92 and a plan, as shown by $ABCDE$. The eave mould H in this case is to be so placed that 1-2 and 3-4 are in vertical positions. From the corners 1 to 5 in H lines are drawn parallel to $F5$ as shown. Take a tracing of H and place it as shown by H^1 in plan and obtain the miter lines B_1^1 , C_1^1 and D_1^1 . Lines are erected from miter lines to intersect similar lines in elevation, as shown by the miter lines \mathcal{Y} and I . To obtain pattern for the eave mould H , take the stretchout of H and place it on $a-b$ in plan, and obtain pattern from intersections on the miter line D_1^1 . Take a tracing of H and place it as shown by H^2 and obtain the true profile for the mouldings HI and $\mathcal{Y}K$, as shown by H^3 . The stretchout of H^3 is now placed on cd and ef , and the patterns for the mouldings HI and $\mathcal{Y}K$ are developed from intersections in H and I , and \mathcal{Y} and K respectively. Before the pattern for $I\mathcal{Y}$ can be laid out, a true elevation and profile must be obtained as follows: Take a tracing of BC in plan and place it as shown by $B'C'$. From C' lines are erected and intersected by those drawn from I in elevation, resulting in L . From 5 in B' erect a line which intersect by a line drawn from 5^o in \mathcal{Y} . Draw a line from 5 to 5 in the true elevation, and parallel to same from the points in L , draw lines which are intersected

by those erected from B^1 , resulting in M . Take a tracing of H and place it as shown by H^1 and obtain H^2 . Take a stretchout of H^2 and place it on hi , and obtain the patterns from intersections on M and L at a right angle to $r-1$. If $r-2$ in both $\tilde{\gamma}$ and I in elevation were allowed to stand at a right angle to the rake, a simpler method could be employed for obtaining the patterns using but one profile, the principles being similar to

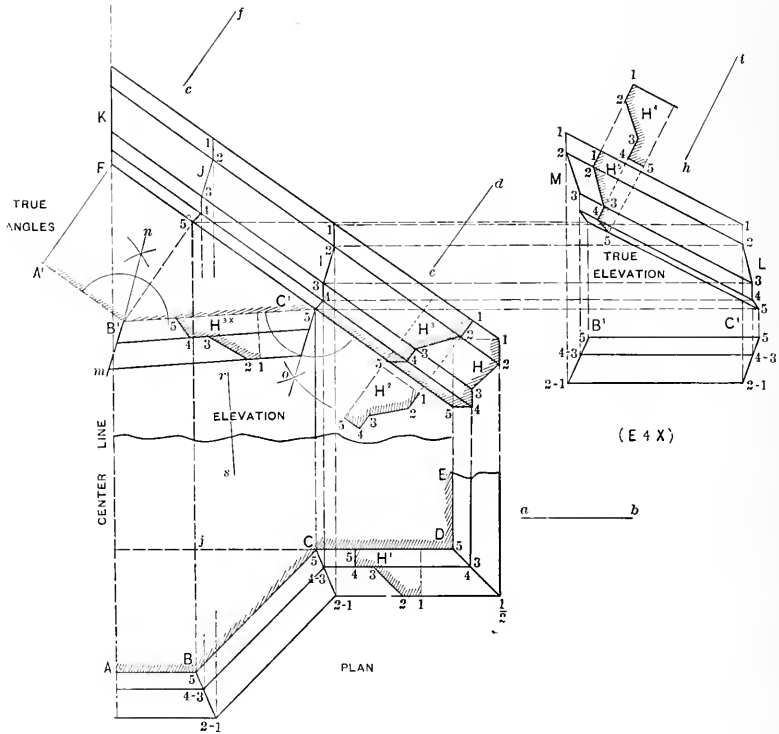

FIG. 92.

that given in Fig. 91. At a right angle to $F5$ in Fig. 92, from points F and 5^o , the lines FA^1 and 5^oB^1 are drawn equal to jB in plan, resulting in the true angle $A^1B^1C^15$. Next place the profile H^2 as shown in the true angles by H^{2x} . A stretchout of this profile is then placed on rs and the pattern obtained from intersections on $n-m$ and $5-o$, which

gives the pattern for the middle moulding. The lower miter pattern H and upper one K , previously obtained from similar letters, are correct, but the upper miter pattern I , for the piece HI and lower miter pattern \tilde{y} for the piece $K\tilde{y}$, must be traced from the patterns obtained from 5-0 and $n-m$ respectively in the true angles.

PATTERN FOR HIP RIDGE

FIGS. 93 and 94. When patterns are to be developed for hip ridges, no matter what their profile, or what angle the roof may have in plan; or whether the sides of the roofs have equal or unequal pitches, the principles given in Figs. 93 to 95 inclusive apply to each case.

In Fig. 93 is shown the elevation of a mansard roof A , with a gutter at the foot and a deck moulding at the top, the deck moulding having an apron attached shown by i in section, which miters with the hip ridge C at c . B is the plan, a right angle as shown by the solid lines or an octagon angle as shown by the dotted lines. A circular corner piece de is attached to the ridge and apron at a and b . Having drawn the elevation the miter for the deck mould could be obtained direct from same, but before the pattern for the hip ridge can be developed, a true face of the mansard must be drawn giving the true angle and miter line. In practice a full elevation is unnecessary. All that is required is the pitch of the roof as shown by DEF , and the patterns are obtained as follows: Take a tracing of FED and place it as shown by FED in Fig. 94, and if the plan of the roof is a right angle, take the length of DF and place it on the vertical line $D^{\circ}F^{\circ}$, and draw the lines $D^{\circ}A$ and $F^{\circ}B$ and intersect same at D° and F° , by vertical lines dropped from D and F in the pitch of roof. Then $AD^{\circ}F^{\circ}B$ is the true face and angle. Knowing the profiles that the hip and apron are to have, place in position as shown by 1-2-3 and $H\tilde{y}$ and draw the lines $\tilde{y}I_2$. With I as center and the desired radius IK , draw the corner piece $\tilde{y}K_3$. Then $\tilde{y}K_3I$ is the pattern for the corner piece. For the apron $H\tilde{y}$, take the stretchout of 1-2-3 and place it as shown from $1'$ to $3'$. Then obtain the pattern shown. For the hip pattern take twice the stretchout of 1-2-3 and place it on $a-b$ drawn at a right angle to $D^{\circ}F^{\circ}$ as shown. Draw the usual measuring lines which intersect as shown. Then L is the upper miter cut joining the apron and M the lower miter cut running parallel to the cornice line. Before bending-up this ridge in the brake, a true profile must be obtained. We know that the profile of the ridge on a horizontal plane is a right angle, but it will be more than a right angle when viewed at right angles to the hip line. The two methods of obtaining this true profile or angle is shown in the plan. Draw the miter line of the plan NO and parallel to it draw RP . Make PD' equal to ED in pitch of roof and draw $D'R$. Then RPD' is the true elevation through ON in plan. At pleasure, at right angle to ON , draw cd , cutting ON at j .

Extend cd , cutting RP at e . From e , at right angle to $D'R$, draw ef . Through e , parallel to RD' , draw hi . Take the distance jc or jd in plan and place it as shown by ec' and ed' . Draw a line from f to c' and d' , getting the angle desired. Next take a tracing

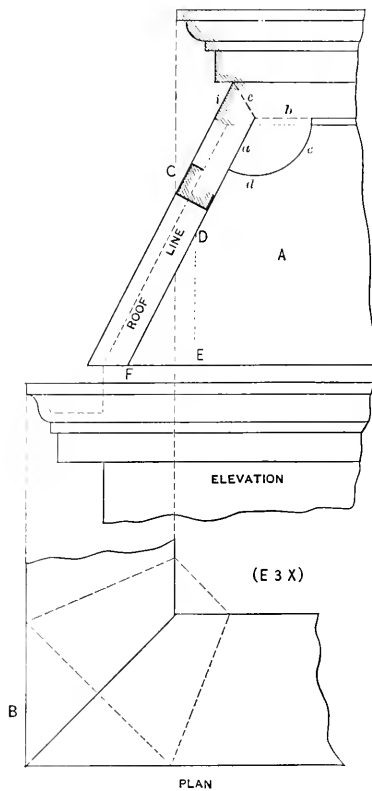

FIG. 93.

of 1-2-3 in the true face and place it as shown by $f-2''-3''$ on either side in the true angle. This same angle could be obtained by taking the distance ef and placing it as shown by ff' in plan and drawing lines from f' to c and d .

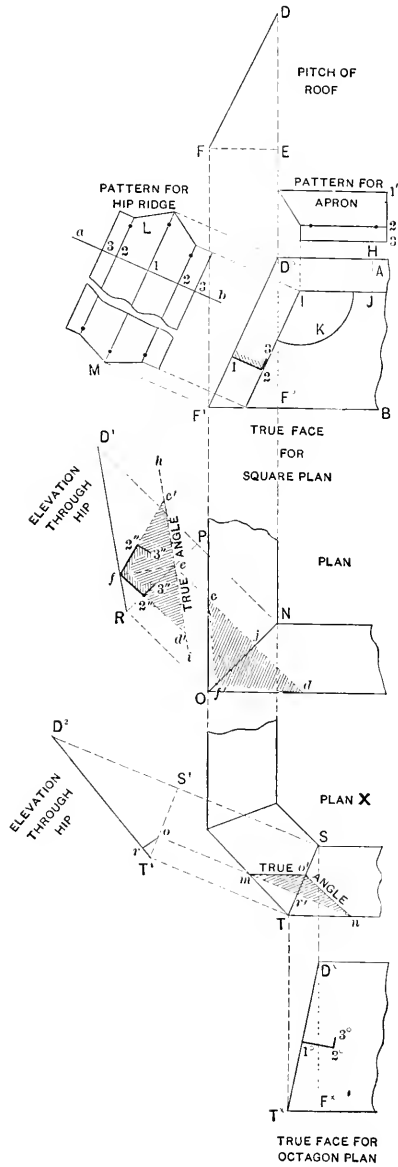

FIG. 94

Using the same pitch of roof, develop the patterns for the apron and hip, when the plan of the roof is an octagon, as shown in plan *X*, Fig. 94. In this case *DF* is placed as shown by $D^x F^x$, and D^x and T^x , obtained from *S* and *T* in plan. The half profile of the ridge is placed as shown by $1^\circ-2^\circ-3^\circ$ and the patterns developed as before. The true angle of the octagon hip *ST* is obtained by drawing $S^1 T^1$; make $S^1 D^2$ equal to *DE* in pitch of roof and draw $D^2 T^1$; *n-m* is extended to *o*, from which *or* is drawn at a right angle to the hip. *or* is then placed in plan from *r'* to *o'* and the true angle obtained.

FIG. 95. In this connection it may not be out of place to apply these principles to roofs having unequal pitches, as shown by *A* and *B* in Fig. 95. *C* is the elevation. Draw the miter line *DE* and draw *a'c* parallel to it. Make *a'b'* equal to *ab*. Draw *b'c*. Draw at pleasure and at a right angle to *DE* the line *cd*, extending same to *c*, from which point draw *cf* at right angle to *b'c*. With *c* as center, draw the arc *fh*, and from *h* parallel to *cE* draw *hi*, which is the same as if we had taken the distance from *c* to *f* and placed it as shown from *s* to *i* in plan. Draw a line from *i* to *c* and *i* to *d*. Then *cdi* is the true angle. In obtaining the miter patterns for the apron and hip ridge, true faces would have to be obtained for each side having a different pitch, in the same manner as shown in the true face for square plan in Fig. 94; the patterns for the aprons are obtained as there shown, but only the pattern for the hip ridge for each side is necessary, because each side has a different pitch in Fig. 95. After obtaining the true angle in Fig. 95, the patterns can be omitted.

FINDING TRUE ANGLES IN IRREGULAR PIECED ELBOWS

FIGS. 96, 97 and 98. When patterns are desired for irregular pieced elbows, the difficulty does not lie in preparing the patterns, but in obtaining the true angles. Fig. 96 is an example that is apt to arise in furnace piping, blower pipes, etc. The pipe *A*¹ leaves the furnace top at an incline, but on a horizontal line *A* in plan. The second section of the elbow *B*¹ not only inclines in elevation as shown, but also away from the horizontal as indicated by *B* in plan. The upper section is vertical as shown by *C*¹ in elevation and *C* in plan. The problem is to find the true angles between the first and second sections and between the second and third sections. After the true angles are secured the elbow patterns are developed in the usual manner, and a slip joint placed in the second section, as shown by *a-b* which will allow the upper elbow to be turned upon the lower one, until their correct relative positions are obtained. The method of obtaining these true angles is shown in Fig. 97, in which *A* and *B* represent respectively the elevation and plan of portion of the furnace hood. When obtaining these true angles it is only necessary to deal with the center lines after which the half diam-

eter of the pipe is placed on either side and the miter line obtained. Therefore we will assume that C in elevation is the point where the center of the pipe will come, that length will equal CD and have a rise equal to ED , leaving the furnace in plan on a horizontal radial line shown by $C^{\circ}D^{\circ}$. The second section of pipe has an incline equal to DF , with a rise equal to GF , but is brought forward a distance equal to HF° in plan, as shown by $D^{\circ}F^{\circ}$. The third section of pipe rises in a vertical line FK in elevation and is shown by the dot F° in plan. For the true angle of KFD in elevation, draw any line parallel

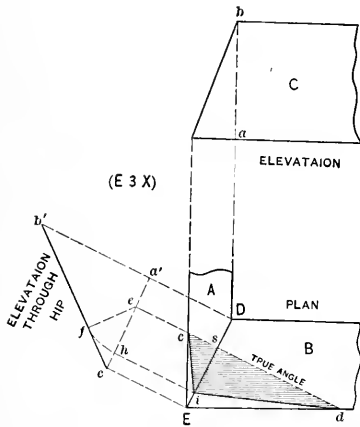

FIG. 95.

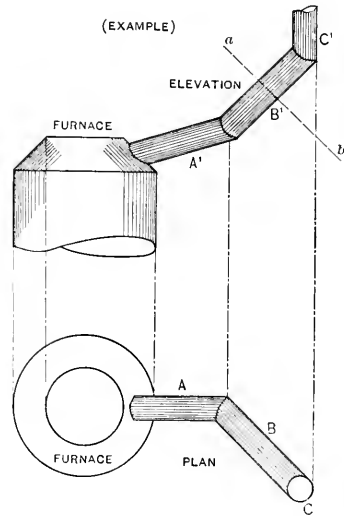

FIG. 96.

and equal in length to $D^{\circ}F^{\circ}$ in plan, as shown by D^1F^1 . Erect the perpendicular from F^1 making F^1F^x equal to GF in elevation. Draw $D^1F^xK^1$, which is the true angle for similar letters in elevation. On either side of $D^1F^xK^1$ place the half diameter of the pipe, draw the miter line ab and develop the patterns in the usual manner. For the true angle of CDF in elevation, take the distance from C° to F° in plan and place it as shown by $C^{\circ}F^{\circ}$ in Fig. 98. Erect the vertical line $F^{\circ}F^{\circ}$ equal to $\tilde{y}F$ in elevation in Fig. 97 and draw a line from F to C° in Fig. 98. This line then represents the base of the

angle to be obtained. As CD in Fig. 97 is the true length of the first section and D^1F^* the true length of the second section, it is only necessary to take the distance of CD as radius and with C° in Fig. 98 as center, describe the arc D , which then intersect by an arc struck from F as center, the radius being F^*D^1 in Fig. 97. Draw the angle FDC°

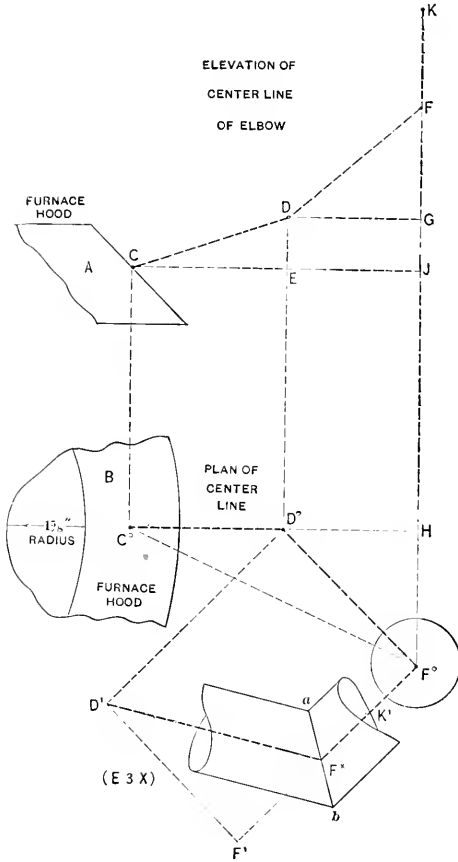

FIG. 97.

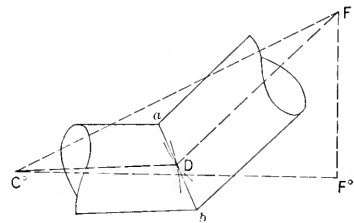

FIG. 98.

in Fig. 98, which is the true angle for similar letters in elevation in Fig. 97. The pipe is now constructed around the true angle in Fig. 98 and the miter line ab , and patterns obtained in the usual manner. The method of obtaining the pattern between the conical hood A and round pipe in Fig. 97 will be described in Part Two.

FIGS. 99, 100 and 101. Applying the principles of the preceeding problems, next obtain the true angle of an elbow turning around a building whose corner is square as shown in the example in Fig. 99, by $A-B$. The pipe C has an angle indicated by a and the pipe D an angle indicated by b . It is immaterial what angle the wall may have in plan, the principles are similar.

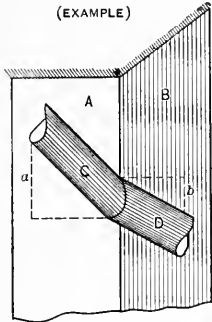

Fig. 99.

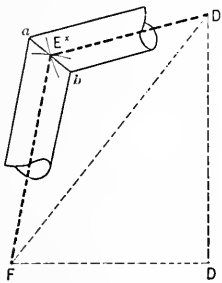

Fig. 101.

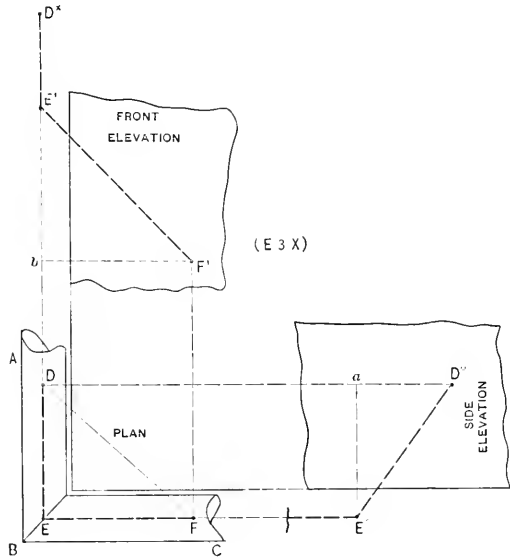

Fig. 100.

In Fig. 100 is shown the plan and elevations. ABC represents part plan of pipes. Draw the center line and locate at pleasure the points D and F . $D^{\circ}E^{\circ}$ in the side elevation shows the true length and pitch of DE in plan, and E^1F^1 in front elevation the true length and pitch of EF in plan; E^1D° in front elevation is equal to aD° in side. Knowing the true lengths, the true angle is found by taking the distance DF in plan and placing it as shown by DF in Fig. 101. From D erect DD^1 equal to bD° in Fig. 100. With $D^{\circ}E^{\circ}$ in side as radius and D^1 in Fig. 101 as center draw the arc E^x , which intersect by an arc struck from F as center and F^1E^1 in Fig. 100 as radius. Then will D^1E^x in Fig. 101 be the true angle. The pipe is then placed in position and the miter line $a-b$ drawn as shown.

PATTERNS FOR HIPPED SKYLIGHT

FIGS. 102, 103, 104, 105, 106 and 107. In Fig. 102 is shown the method for obtaining the patterns for a hipped skylight with ventilator. These same principles are applicable to skylights having single or double pitches with or without ventilators. The method of computing the lengths of the hip, common and jack bars in various sized skylights when the curb measure is known, will also be explained. The skylight drawings are one-fourth full size or three inches to one foot, so that when the full size patterns are developed they can be used in shop practice. In obtaining the length of the various bars, measurements are taken upon the glass line, so that the size of the glass can be obtained and cut, before the skylight is set together, which avoids unnecessary delay.

The usual pitch for hipped skylights is one-third the span. In other words, if the run is 6 feet, the rise will be $\frac{1}{3}$ or two feet. Knowing the pitch wanted (in this case one-third) proceed to draw the half section as follows: Draw the center line CA^1 at right angles to which, from A , draw AB equal to 12 inches; make AC 8 inches or one-third of 2×12 , and draw CB . Draw the lower curb B as shown, also the upper bar E , and place in the position shown the profile of the common bar D . Complete the ventilator as shown by the sections F and G , also the section of the brace H . If no ventilator was wanted, the ridge bar \mathcal{F} would be placed in the position shown, by tracing E on either side of the center line. For the common bar pattern take the stretchout of D and place it on the line $a-b$ as shown, and draw the usual measuring lines which are intersected by lines drawn from B and E , resulting in the pattern shown. When measuring the length of the common bars, line 2 in the pattern is used, because the hypotenuse of the triangle CBA falls upon line 2 in the half section. To obtain the patterns for the hood G , brace H , outside vent F , and inside vent E , take stretchouts of each of these parts and place them on the vertical line cd , as shown in Fig. 103. Draw measuring lines as shown and intersect same by taking the various distances from the center line in the half section in Fig. 102 to the different points in the ventilator, and placing them on either side of the center line cd in Fig. 103. Then G^1 , H^1 , F^1 , E^1 are the patterns for the parts having similar letters in the half section in Fig. 102. The arrow points on the patterns in cd in Fig. 103 indicate where measurements must be taken when laying out ventilators for different size skylights. The pattern for the curb in Fig. 102 is obtained by taking the stretchout of B and placing it on hi as shown, after which the measuring lines are intersected by lines dropped from B . The letters e and f in the pattern B^o indicate where the holes should be punched to allow the inside condensation to escape to the outside at 4 in B . The measuring line in B^o is indicated by the arrow. Before the pattern for the hip bar can be obtained, a plan view must

be drawn as shown. As the plan of the skylight is to be square, the hip line $A'B'$ is drawn at an angle of 45° . If the plan of the skylight were other than a right angle, the

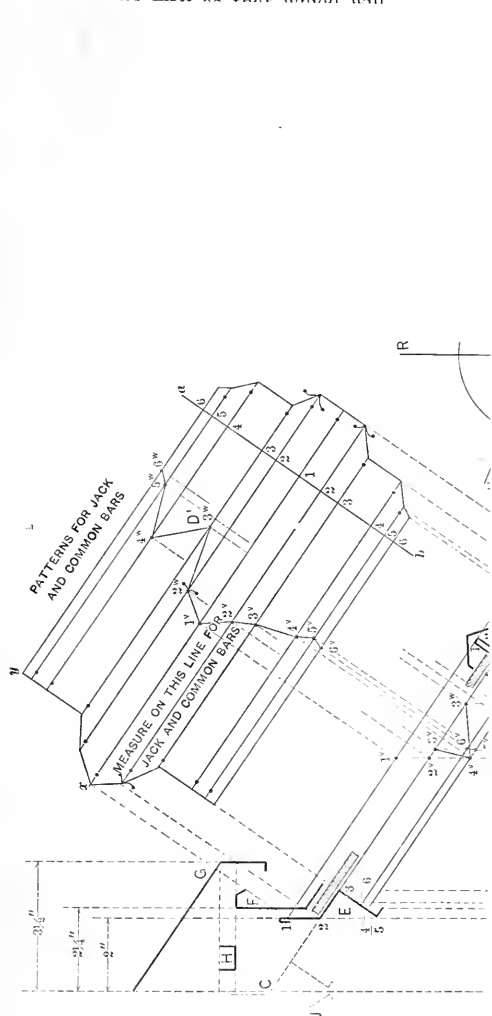
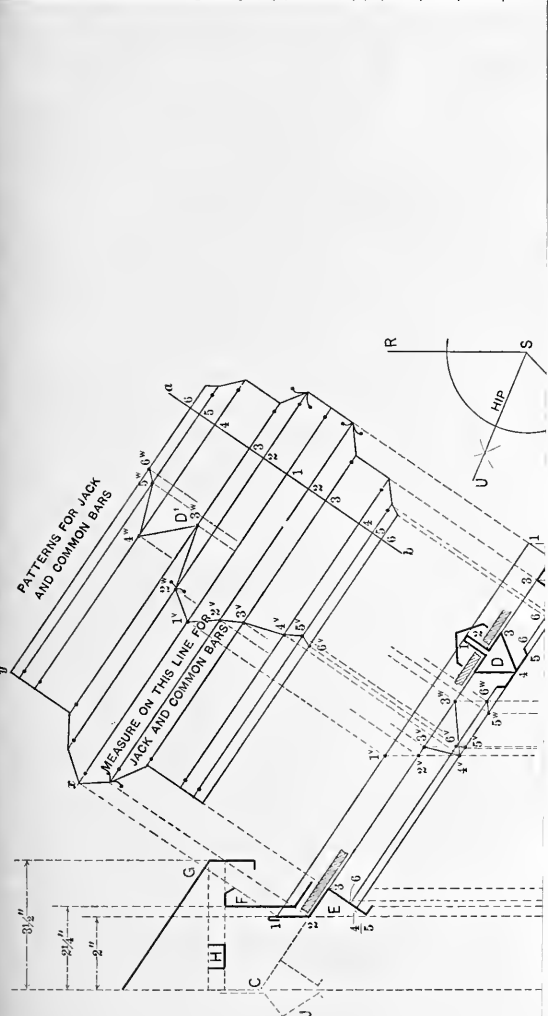



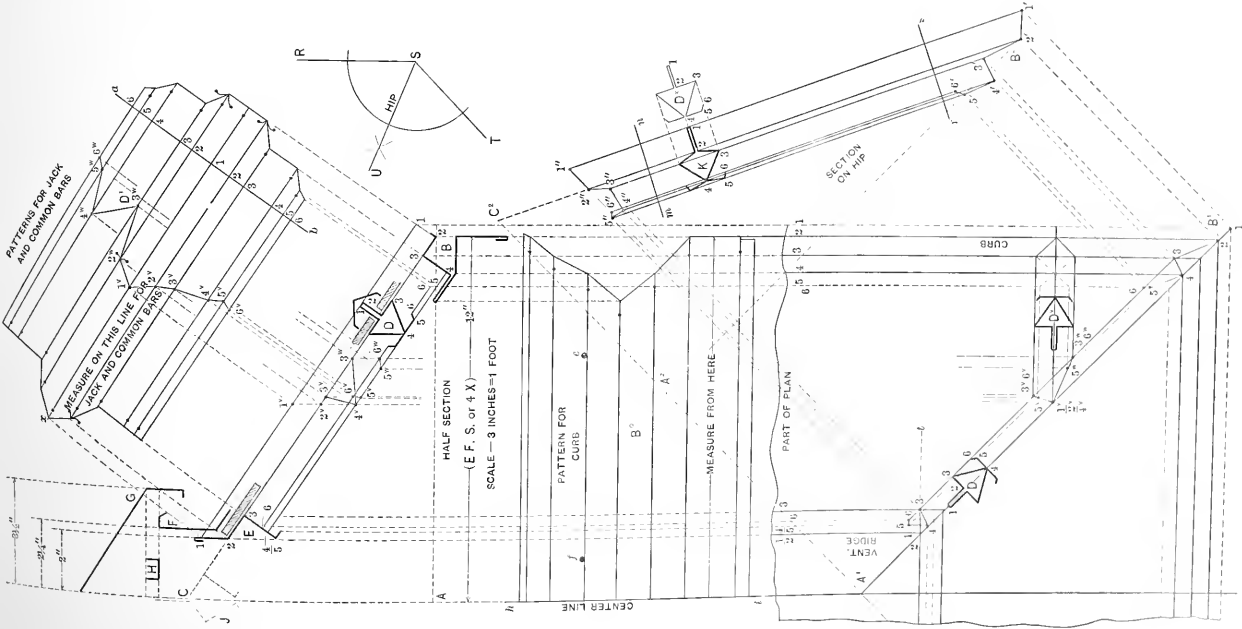

FIG. 102.

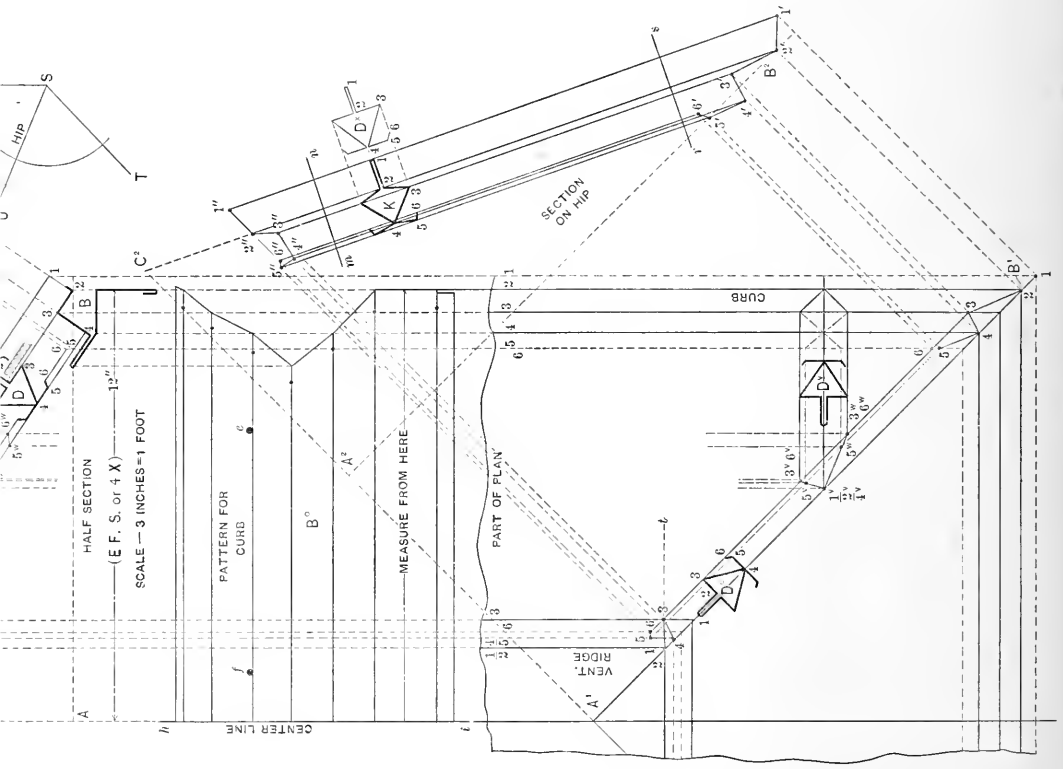

Fig. 102.

be drawn as shown. As the plan of the skylight is to be square, the hip line A^1B^1 is drawn at an angle of 45° . If the plan of the skylight were other than a right angle, the pattern for the hip would be developed in precisely the same way as that which will follow, bearing in mind that the miter or hip line would be the bisection of the given angle, as shown by $RSTU$. From the various intersections in B and E in the half section drop lines intersecting the hip line in plan as shown, from which points horizontal lines are drawn as shown, completing the quarter plan. A profile of the common bar D is now placed on the hip line A^1B^1 in plan, as shown by D^o , so as to obtain the horizontal measurement. Through the small figures in one-half of D^o , lines are drawn parallel to A^1B^1 , intersecting those previously dropped from B and E in the half section, and resulting in the points of intersections 1 to 6 in B^1 and 1 to 6 in A^1 . Parallel and equal to A^1B^1 draw A^2B^2 , making A^2C^2 equal to AC in the half section. Draw a line from C^2 to B^2 . From the various intersections in plan 1 to 6 at the curb and 1 to 6 at the ridge, erect lines indefinitely as shown. Measuring from the line AB in the half section, take the various heights to points 1 to 6 in B and E and place them on similar lines erected from plan, measuring in each instance from the line A^2B^2 in the hip section, and resulting in the points of intersections $1'$ to $6'$ in B^2 and $1''$ to $6''$ at the top vent ridge. Connect the similar points by lines as shown, which, if correct, must run parallel to C^2B^2 . This then represents the true section on the hip line in plan. The true profile of the hip bar is found by placing a duplicate of D as shown by D^x and perpendiculars drawn, intersecting similar lines in the hip section. By connecting points as shown by K , the desired profile is obtained. The pattern for the hip could be drawn at a right angle to $1'-1''$, but for want of space it has been transferred as shown by K^1 in Fig. 103. Take the stretch-out of K in Fig. 102 and place it on $m'-n'$ in Fig. 103 as shown. Draw the usual measuring lines as shown. Now draw at pleasure in Fig. 102 the two perpendiculars in the hip section, shown by $m-n$ and rs . With the dividers, take the various distances from $m-n$ to points $1''$ to $6''$, and place them in K^1 in Fig. 103 on similar lines, measuring from $m'-n'$. Make the distance between the lines $m'-n'$ and $r'-s'$ equal to the distance between similar lines in the hip section in Fig. 102. Measuring from $r-s$ take the various distances to $1'-6'$ and place them on similar lines in Fig. 103, measuring from $r's'$. Trace lines through these points, which gives the pattern for the hip bar. The arrow points indicate the measuring line. The last pattern is that of the jack bar, shown in Fig. 102. Take a tracing of D and place it in any position horizontally in plan, as shown by D^v . Through the various points in D^v , draw horizontal lines, intersecting similar numbered lines in the hip bar in plan as shown from 1^v to 6^v and 1^v to 6^w . From these intersections lines are carried into the half section, intersecting similar lines, resulting in the points of intersections 1^v to 6^v and 1^v to 6^w , from which, at right angle to CB , similar lines are intersected in the pattern D^1 by dotted lines, as shown by similar numbers. This gives the pattern for the upper cut of the jack, the lower cut being similar to that shown on the common bar. If a ridge bar is desired in place of the

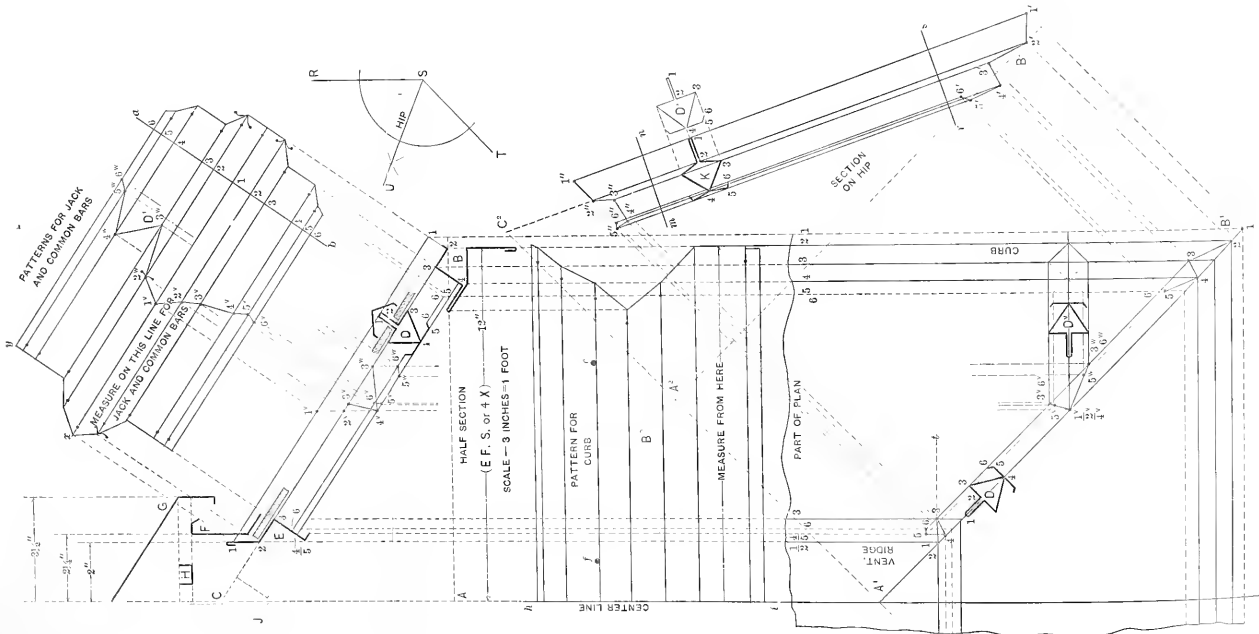

FIG. 102.

ventilator, the pattern shown by E^1 in Fig. 103, could be used, simply duplicating E^1 opposite the line ef , so as to form up the profile \tilde{f} in the half section in Fig. 102. In using a ridge bar, the common and hip bars are sometimes attached in a manner shown in Fig. 104. A is the ridge bar intersected by the two hips B and B and requires a miter cut $2-l$. The miter cut $2v$ is shown in Fig. 103 in the pattern K^1 from v to w . For the cut $2t$ in Fig. 104 it would only be necessary to draw a horizontal line from 2 in plan in Fig. 102,

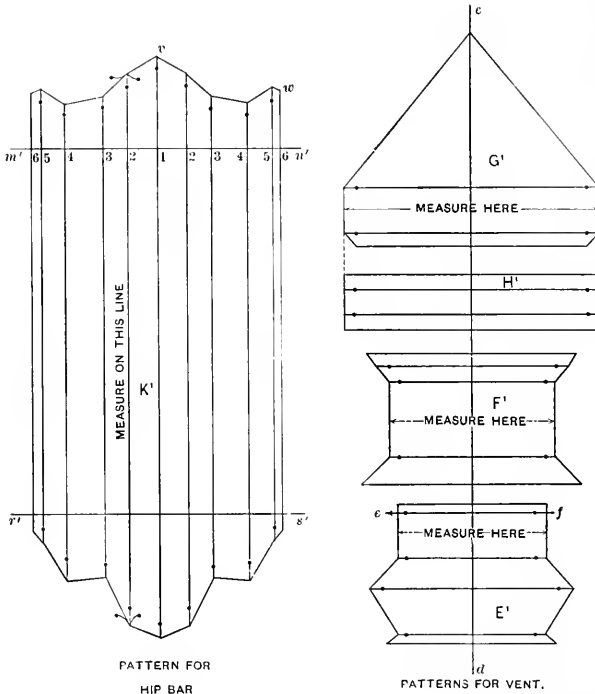

FIG. 103.

as shown by $2t$, and where this line intersects the various lines in the half hip, project lines at a right angle to the hip line, and intersect similar numbered lines in the hip section. Measurements are then taken from the line $m-n$ to these points and transferred to the pattern K^1 in Fig. 103 on the opposite side of vw . While this pattern has been omitted for want of space, the student should project these points to his pattern on the full-size drawing. When the common bar C in Fig. 104 intersects the two hips

BB , the cuts $2a$ and $2a$ are similar to the miter cut shown from 1^v to 6^w in the pattern D^1 in Fig. 102. If the center of the common bar D in Fig. 104 were attached, as shown at 2, then the cut $2c$ would be the same as xy in D^1 in Fig. 102 and $2b$ in Fig. 104, the same as 1^v-6^w in D^1 in Fig. 102. To illustrate the rule for obtaining the lengths of the various bars in any given size skylight, Figs. 105 to 107 have been prepared. Take a tracing of ABC in the half section in Fig. 102, and place it as shown by ABC in Fig. 105. Divide AB into inches, half inches and quarter inches, and erect vertical lines cutting BC as shown. This triangle is then used for obtaining the true lengths of jack and common bars. In similar manner take a tracing of $A^2B^2C^2$ in the section on hip

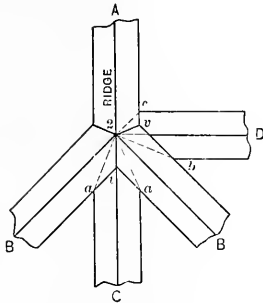
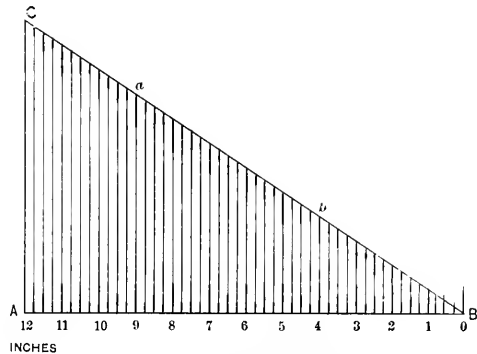

FIG. 104.



OBTAINING FULL SIZE MEASUREMENTS FOR JACK AND COMMON BARS.

FIG. 105.

in Fig. 102 and place it as shown by similar letters in Fig. 106. As A^2B^2 represents the plan of the hip bar, whose common bar measures 12 inches in plan, then divide A^2B^2 into twelve equal parts as shown, and project lines upward intersecting B^2C^2 as shown. This triangle will be used for obtaining the length of the hip bar. Assume that two skylights are to be constructed, the curbs being 4×8 feet as shown at A in Fig. 107, one without a ventilator as shown by the solid line, and one with a ventilator 6 inches wide, as shown by the dotted lines. Knowing the size of the curb, the pattern shown by B^0 in Fig. 102 is used, measuring from the arrow points. To obtain the lengths of the ventilator, ridge, common, jack and hip bars the following methods can be employed, no matter what size the skylight may be. In the following rules S will indicate the shortest side of curb, L the longest side and V the given width of the ventilator.

Rule I. To obtain the true length of the ridge bar.

$$L - S = \text{length of ridge bar.}$$

Rule II. To obtain the true length of the ventilator.

$$L - S + V = \text{length of ventilator.}$$

Rule III. To obtain the measuring lengths of the common and hip bars when no ventilator is used.

$$\frac{S}{2} = \text{measuring length for common and hip bars.}$$

Rule IV. To obtain the measuring lengths of the common and hip bars when a ventilator is used.

$$\frac{S - V}{2} = \text{measuring length for common and hip bars.}$$

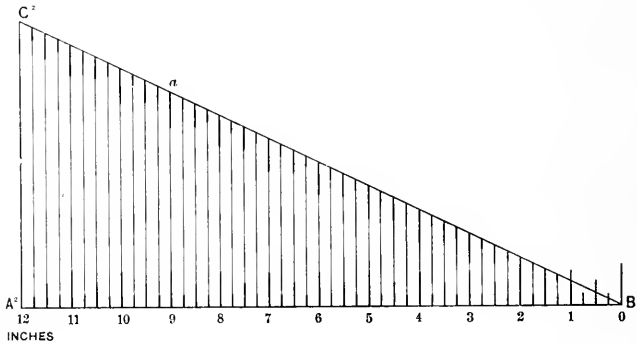

OBTAINING FULL SIZE MEASUREMENTS FOR HIP BARS

FIG. 106.

To obtain the measuring length of the jack bar use dimensions in diagram as given in Fig. 107. The first step in applying the foregoing rules is to make a diagram as shown at A, giving the size of glass and divisions of the bars. Then the length of the ridge bar a would be 8 feet - 4 feet = 4 feet, to be measured from the arrow points in E^1 in Fig. 103. The length of the ventilator in A in Fig. 107 would be 8 feet - 4 feet = 4 feet + 6 inches = 4 feet 6 inches, to be measured from the arrow points in E^1 in Fig. 103. The length of F^1 would be 4'-6½" and the hood G^1 , 4'-9", because F and G in the half section in Fig. 102 project over E, ¼ and 1½ inches respectively. Referring to A in Fig. 107 the measuring lengths of the common and hip bars, when no vent is used, would be 4 feet ÷ 2 = 2 feet. As AB in Fig. 105 equals 1 foot, then for 2 feet the length of the common bar would be twice CB, measuring from arrow points in the pattern for common bar D^1 in Fig. 102. Using the same measuring length, the hip bar would be twice C^2B^2 in Fig. 106, measuring from arrow points in K^1 in Fig. 103. If a 6-inch vent was employed, as shown in Fig. 107, the measuring length would be 4 feet - 6 inches

= 3 feet 6 inches \div 2 = 1 foot 9 inches. The true length of the common bar would then be equal to CB in Fig. 105 plus the distance aB , which is found by erecting the line from 9 to a . The true length for the hip bar would be found by taking the distance C^2B^2 in Fig. 106 plus aB^2 . As the dimension of the jack bar in Fig. 107 is 1 foot 4 inches, the true length is found by taking the distance CB in Fig. 105, and adding

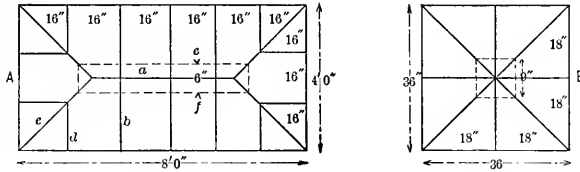

FIG. 107.

to it, the distance bB , which is found by erecting a line from 4. This length is then measured from the arrow points in the pattern for jack bar D^1 in Fig. 102. If desired, all the glass can now be cut, before the skylight is set together, the length of the glass being equal to the length of the bar, and the width equal to the dimensions in Fig. 107, minus $\frac{1}{4}$ inch in length and width for play room.

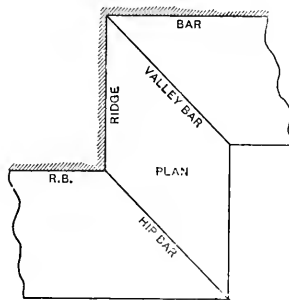

FIG. 108.

FIG. 108. Make a new drawing of the half section in Fig. 102 without a ventilator, and develop the pattern for a valley bar only, as shown in the reduced plan in Fig. 108. Compute the lengths of the common and hip bars in the skylight, the size of which is shown at B in Fig. 107, one without a ventilator and one with a ventilator 9 inches square. Find the lengths of the various pieces in the ventilator.

PART TWO — THE PRINCIPLES OF RADIAL LINE DEVELOPMENTS

FIGS. 109, 110 and 111. By radial line developments we mean patterns that have been developed by means of radial lines, converging to a common center. The forms or shapes considered within this part have for their base either the circle, figures of equal or unequal sides, or any of the regular polygons that can be inscribed in a circle, the lines drawn from the corners of which would terminate in an apex or point, directly over the center of its base as shown in Figs. 109 and 110. In Fig. 109 *ABCD* represents the base of a circle, the center *E* coming directly under the apex *F*. Knowing the height of the axis *EF*, all lines drawn from either of the points in the circle as *A*, *B*, *C* and *D*, will terminate at *F* as shown, and all lines will be of equal length and pitch because the apex *F* appears directly over the center point *E*. This is equally true when

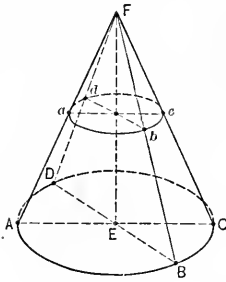

FIG. 109.

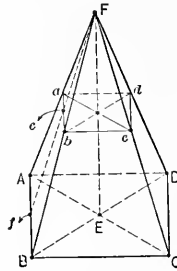

FIG. 110.

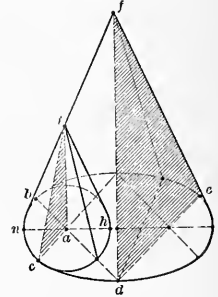

FIG. 111.

a frustum of a cone is employed, as shown by *abcd*, the pitch and length of the lines *Fa*, *Fb*, *Fc* and *Fd* being equal. What is true of the circle is also true of any other figure the base of which can be inscribed in a circle. In Fig. 110 a pyramid is shown, the base *ABCD* being square and the axis equal to *EF*. In these cases all lines drawn from the corners also terminate at the apex *F*. The length of any one of these lines becomes the radius by which to strike the pattern, but *Fj* represents the true length of the pitch at right angle to the base *AB*, while *cf* would be the true pitch if a frustum was desired, as shown by *abcd*. *Fb* and *FB* would be the radii with which to describe the frustum. There is still another figure which should be considered in this part, and while its base is not a true circle, it is composed of arcs of circles, shown by the ellipse in Fig. 111; *a* being the center from which the arc *bc* is struck, and *d* the center from which *bc* is struck. The principle in this figure is the same as in Fig. 109. In Fig. 111 *df* is the axis of the larger curve, and *fc* or *fb* the radius by which to strike the pattern, while *ai* is the axis of the smaller curve, and *ih* or *in* the radius by which to

strike the pattern. The patterns for another figure known as the scalene cone, can also be developed by means of radial lines, although its apex is not directly over the center of its base. This figure will be considered in Part Three.

When obtaining patterns for tapering forms the following rules should be employed.

(1.) There must be an elevation, section or other view, showing the true height of the axis, see aA in Fig. 112, and the true length of the radius with which to strike the pattern as shown by AB or AC .

(2.) A plan must be drawn from which the stretchout can be obtained as shown by $B'C'$.

(3.) This stretchout, if measured along the plan of the base as shown, must be laid off on the arc $1-1'$ in the pattern, which represents the base; or if measured along the plan of the top as $E'D'$, it must be laid off on the arc drawn from ED in elevation, as DF .

(4.) Should a curved, irregular or straight line be drawn through any cone, as illustrated by the straight line $a-b$ in Fig. 114, and which the radial lines in elevation will intersect, then, from these intersections on $a-b$, lines must always be carried at right angles to the axis $A-4'$, until they intersect the true length used to describe the pattern, as shown from 1 to 7 on $A-7'$. With A as center, the points of intersections are then carried to similar radial lines in the pattern, as shown from 7^x to 7^x .

(5.) When obtaining the true section on any curved or straight line as $a-b$ in Fig. 114, which is not at a right angle to the axis line, the shape of the section when developed will be different in shape from that shown in the plan for base, and must be obtained as indicated in the illustration. This will be explained in detail in the problems that follow.

PATTERN FOR A RIGHT CONE

FIG. 112. First draw the center line $A-7$, upon which place the height of the cone as Aa ; through a draw the horizontal line BC , making aC or aB equal to one-half width of the base, and draw lines from B and C to A . Then AC or AB is the radius with which to describe the pattern. In practice the half elevation only is required. Directly below the elevation, draw the plan of the base $B'C'$, which is divided into equal spaces shown from 1 to 12. The radial lines drawn in plan and elevation are not necessary, but are shown to make clear their relation to each other. To obtain the pattern for the cone, use A as center, and with AC as radius, describe the arc $1-1'$. From 1 draw a line to A , and set off on $1-1'$ the stretchout of the base $B'C'$, and draw a line from $1'$ to A . Then $A-1-1'$ is the desired pattern for the cone. If a frustum of a cone is desired, as shown by $BCDE$, then using AD as radius the arc DF would be drawn, making $D-F-1-1'$ the desired pattern. $E'D'$ represents the section of the top

PATTERN FOR FRUSTUM AND SECTION OF RIGHT CONE

FIG. 114. Shows the method of obtaining the frustum and section of a right cone when the upper plane $a-b$ is oblique to the line of its axis. First draw the elevation of the cone $A-1'-7'$ and directly below it the plan view on the line $1'-7'$. Divide the plan into equal spaces as shown by the small figures 1 to 7, and draw radial lines to

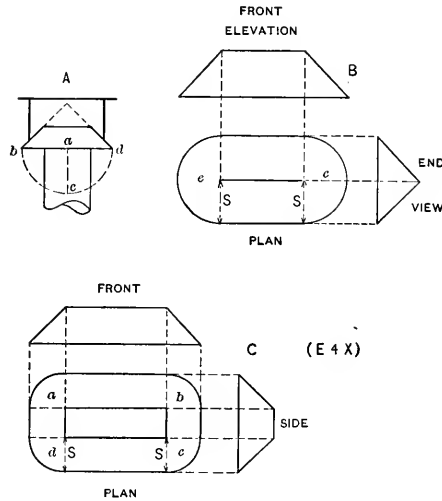

Fig. 113.

the center A' . From the various intersections 1 to 7 erect lines intersecting the base of the cone from $1'$ to $7'$, and from the latter intersections draw lines to the apex A . Let ab represent the plane drawn oblique to the axis of the cone, which also intersects the radial lines from 1 to 7. Using A as a center and with $A7'$ as radius, describe the arc $7''-7''$, upon which the stretchout of the plan is placed, as shown by similar numbers on the arc $7''-7''$. From these points draw radial lines to A . From the various intersections on $a-b$ at right angles to the axis line, draw lines as shown, cutting the line $A-7'$ from 1 to 7. Then using A as center with radii equal to the various divisions as A_1, A_2, A_3 , etc., draw arcs, intersecting similar radial lines in the pattern giving the intersections 7^x to 7^x . A line traced through points thus obtained as shown by $7^x-7''-1''-7''-7^x-1^x-7^x$ will be the desired pattern. If the pattern or true section was desired so as to close the top ab in elevation, whether the line were curved as shown by $m-n$ in Y or vertical as shown by st in X , the same principle would be employed

as that used in obtaining the section on $a-b$. From the various intersections 1 to 7 on $a-b$, drop vertical lines, intersecting similar radial lines in plan as shown from 1° to 7° ; to obtain the point 4, a horizontal line is drawn through 4, until it intersects the side of the cone at d , from which point it is carried vertically to the plan, inter-

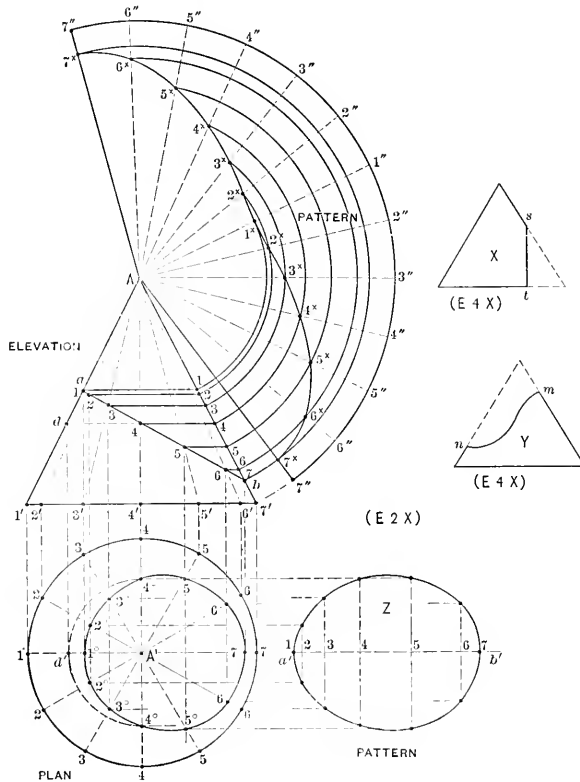

FIG. 114.

secting the center line 1-7 at d' ; then using A' as center describe the arc cutting the radial line 4-4 at $4^\circ-4^\circ$. Next take the stretchout of $a-b$ and place it on the center line 1-7 extended in plan as $a'b'$. At right angle to $a'b'$ through the various points, draw vertical lines, which intersect by horizontal lines drawn from similar points 1° to 7° in plan, and resulting in the pattern Z. In Fig. 114 obtain the developed sections only for the vertical plane st in X and the curved plane $m-n$ in Y, using the method shown in getting out the pattern Z.

FIG. 115. Develop the pattern for the head *mnor* in Fig. 115, shown in plan by *aebcjd*. Draw the center line *Sm* and extend *no* obtaining *t*, which is the center point from which to strike the pattern. Develop this pattern below the plan, placing on the outer arc twice the girth of *ae* in plan.

FIG. 116. Develop the patterns for the foot and body of a hip bath, shown in Fig. 116 by *abcdjh*, the outline being indicated by *bc*, which is drawn at pleasure. The centers are represented by *j* and *i* from which points strike the patterns. The plan *A* represents a section through *dc*. Vertical lines are erected from the plan, cutting *bc* as shown, and from these intersections lines are drawn radially from *j*, cutting *bc*, from where they are carried at a right angle to the center line until they cut the side *bc*; then proceed as shown in Fig. 114, placing the patterns in any convenient position in Fig. 116.

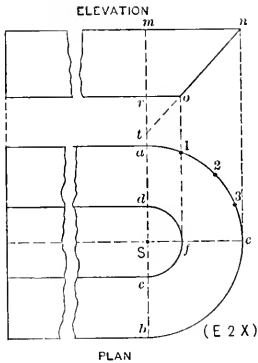

Fig. 115.

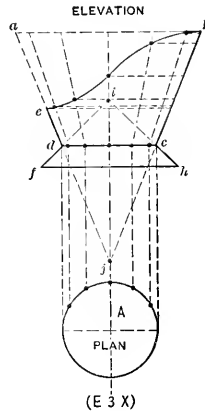

Fig. 116.

FIG. 117. Obtain the pattern for a tapering collar *ced* in Fig. 117, when the roof has a single pitch as shown by *AD*, also when it has a double pitch shown by *FED*. *a-b* represents the center line of the collar, *b* being the apex of the cone and *B* the half section on the line *cf*.

FIG. 118. Develop the pattern for a conical boss shown by *EFGH*, *AB* representing the part plan of the can, while *EHLj* shows the half section on the line *EH*. *DC* shows the center line through the boss, and *C* the center from which the arc *AB* is struck.

FIG. 119. Develop the patterns for the double scale scoop *HEFGDj*. It is to be cut from the two cones *ABCD*. Apply the method used in Fig. 116.

PATTERN FOR SQUARE PYRAMID

FIG. 120. Shows the development of a pattern for a square pyramid; this principle is applicable to the various shaped ornaments arising in cornice work or other articles in the sheet metal line. First draw the center line Aa , and set off the distance aC and aB and draw the elevation ABC . In its proper position draw first the plan, r ,

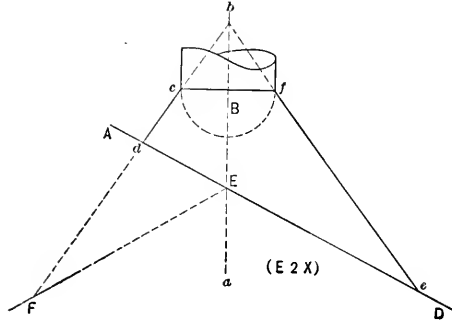

FIG. 117.

2, 3, 4, and then the miter lines 1-3 and 2-4. AB or AC represents the true length on $a'b$ in plan, but the true length on $a'-2$ in plan must be found, by erecting the per-

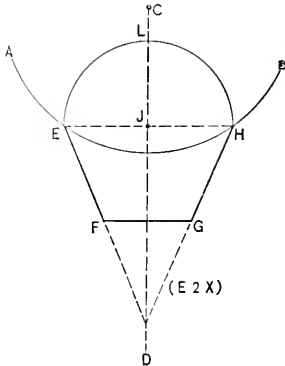

FIG. 118.

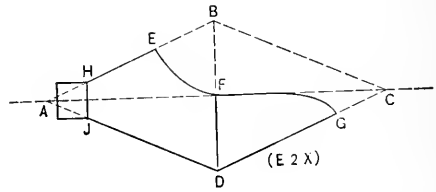

FIG. 119.

pendicular $a'A^1$ equal to the vertical height aA in elevation. The line A^12 then represents the true length or radius with which to develop the pattern. With any point

as A^2 as center, describe the arc $1'-1''$. Set the dividers equal to the spaces in plan and step off on the arc $1'-1''$, the divisions shown by $2'-3'$ and $4'$ and draw lines to the apex A^2 . Connect lines with the outer corners, then will $1'-3'-1''-A^2$ be the desired pattern.

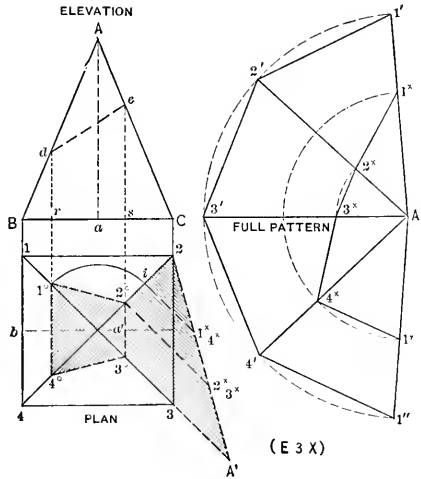

FIG. 120.

FIG. 121. Using the same rule given in the preceding problem, develop the patterns for the pyramids shown in Fig. 121. All elevations are to be similar to ABC and the plans as shown by D, E, F, G and H . Note that all of these plan views are inscribed in circles, and the lines drawn from the corners of same, terminate in an apex, directly over the center of their base. Each plan is to have a separate elevation, with a vertical height equal to Aa . The radius with which to develop the patterns is obtained in each case by placing the vertical height Aa at a right angle to the miter line in the various plans, as shown by a', a'', a''', a^o and a^x . AX' represents the line in elevation on the corner X in plan H . The center point in the plan D can be obtained by bisecting bd , and obtaining e , through which draw a line towards f until it intersects the center line Ad . The shaded section in each plan represents the true sections on the respective miter lines.

PATTERN FOR FRUSTUM AND SECTION OF SQUARE PYRAMID

FIG. 122. Draw the plan and elevation of a square pyramid, similar to Fig. 120, and develop the pattern as shown on that plate. Draw the oblique plane de and obtain the frustum as follows: From the intersections d and e , drop vertical lines, inter-

secting similar lines in plan as shown by the shaded portion. With a' as center and $a'1^\circ$ as radius, describe the arc cutting $2-4$ at i . Erect the perpendicular from i , cutting $A'2$ at 1^x4^x ; also from 2° erect a line cutting $A'2$ at 2^x3^x . Then $i1^x$ and $2^\circ-2^x$ will equal rd and se respectively in elevation. Using A^2 in the pattern as center, and with $A^1-2^x3^x$ and $A^1-1^x4^x$ as radius, intersect similar lines in the pattern and obtain points of intersections $1^x, 2^x, 3^x, 4^x, 1^x$. Then $1^x-1^x-1^x-1^x$ will be the pattern for the frustum. The true section on de is obtained by taking this distance and placing it on any line as de in Fig. 122, making $e2^\circ, c3^\circ$ and $d1^\circ$ and $d4^\circ$ equal respectively to $a'2^\circ, a'3^\circ$ and the distance from the center line to 1° and 4° in plan in Fig. 120.

FIGS. 123 and 124. Obtain the frustum and section of the hexagonal pyramid shown in Fig. 123, in which ABC represents the elevation cut by the oblique plane DE . The plan view on the base line is shown and the horizontal section through ED appears shaded. The intersection between the plane ED and the center miter line a''' is shown in plan by $a'-a'''$ and is obtained by projecting a horizontal line to a on AC , then to a in plan, then to a' and a''' as shown by the semi-circle. The true length on the hip line in plan is obtained by taking the distance cd and placing it as shown by $c'd'$, then obtaining A° . From the various intersections on ED , lines are projected to $A^\circ d'$. The pattern for the frustum is shown in Fig. 124, the various radii in Fig. 123 on $A^\circ d'$, being used and intersecting similar miter lines in Fig. 124. The true section on ED in Fig. 123 is shown by $E^\circ D^\circ$.

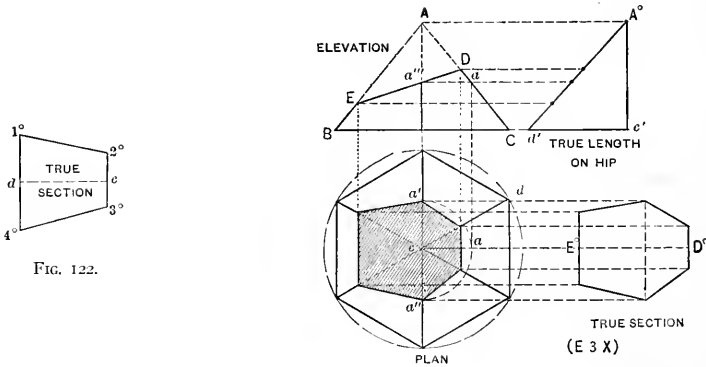

FIG. 122.

FIG. 123.

FIG. 125. Obtain the frustum and section of a pyramid when the plan is irregular as shown. The center point i in plan is obtained by bisecting ac by the line ef . In this case AC shows the true length of the hip, because it lies in a horizontal plane in

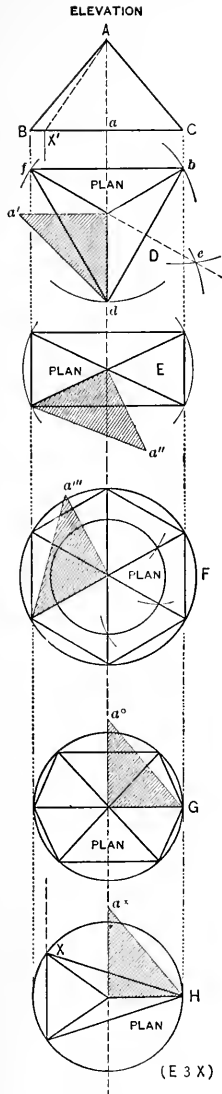

FIG. 121.

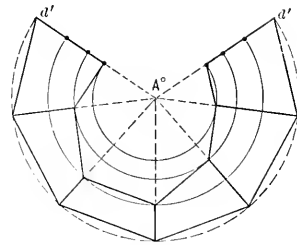

FIG. 124.

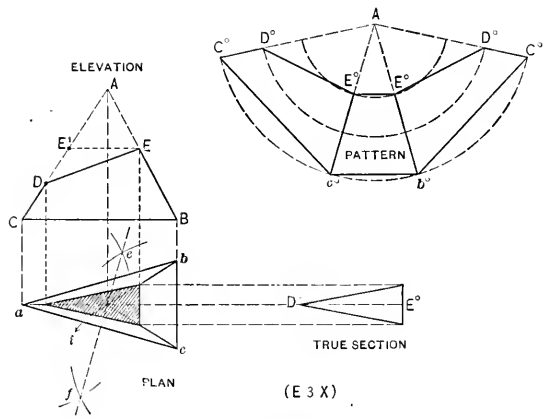

FIG. 125.

plan as shown. The patterns for the frustum and section are developed, as shown by similar reference letters.

PATTERN FOR ELLIPTICAL FLARING ARTICLE

FIGS. 126 and 127. Show the method of developing the pattern for an elliptical flaring article. These principles are applicable to any shape or form constructed of arcs of circles. Draw the plan view according to the rule given in Figs. 8 or 9 in Part One and obtain the centers A, B, A', B' in Fig. 126. Draw the elevation $CDEF$ and obtain

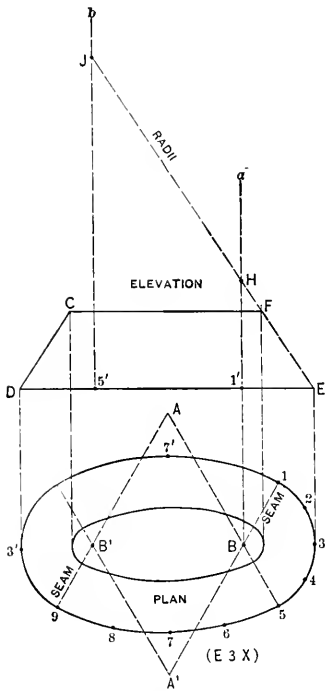

FIG. 126.

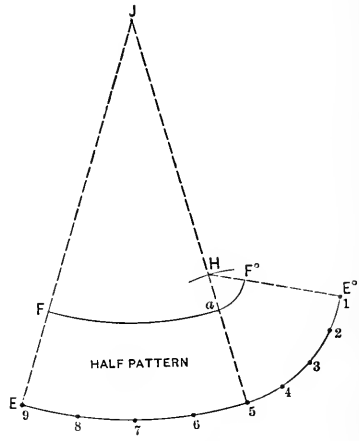

FIG. 127.

the radii with which to strike the pattern, by taking the distances in plan $B-1$, and $A-5$, and placing them in elevation as shown, respectively by $E-1'$ and $E-5'$. From $1'$ and $5'$ erect perpendicular lines, a and b , which intersect by the flare EF extended, at H and J . Then JE is the radius with which to strike the pattern for that part shown by $9-5-A$ in plan, and HE the radius for that part shown by $1-5-B$ in plan. With JE

as radius and \tilde{y} in Fig. 127 as center, describe the arc 9-5. Starting at any point as 9 set off on 9-5 the stretchout of 9-5 in plan in Fig. 126. Draw lines from 5 and 9 to \tilde{y} in Fig. 127. Then with HE in Fig. 126 as radius and 5 in Fig. 127 as center, describe an arc, cutting 5- \tilde{y} in H . Using the same radius and H as center, draw the arc 5-1, on which lay off the stretchout of 5-1 in plan in Fig. 126. In Fig. 127 draw a line from 1 to H . Now, with radii equal to $\tilde{y}F$ and HF in Fig. 126 and with centers \tilde{y} and H in Fig. 127, describe the arcs Fa and aF° . $FF^\circ E^\circ E$ is then the half pattern with seams at 1 and 9 in Fig. 126.

FIG. 128. Solve the problem shown in Fig. 128, the plan of which is an egg-shape oval; the elevation is shown by A , the plan by B , and the various radii with which to develop the pattern by CD . In striking the pattern have the seam come at $S-S$ in plan.

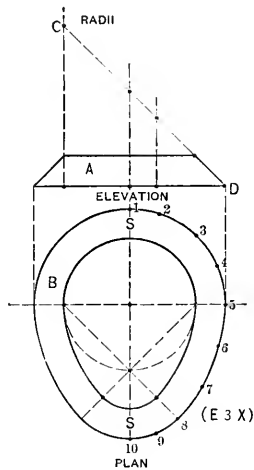

FIG. 128.

PATTERN FOR TAPERING ELBOW, ROUND IN SECTION

FIGS. 129 and 130. The former illustrates the method of obtaining the patterns for a three-pieced tapering elbow, which, when completed, will appear at an angle of 90° , as shown in Fig. 130 by dotted line through center. The method here explained of finding the true miter lines and developing the patterns in Fig. 129, apply to any pieced tapering elbow, no matter what degree it may have. First draw the elevation

of the frustum of a cone from which the several pieces are to be cut, as shown by *ABCD*. Extend the sides until they meet in the apex *E*. On *DC*, with *F* as center, draw the half section of the pipe as *D₄C*. Divide this half section into equal spaces, from which points erect perpendicular lines, cutting the base *DC* as shown. From the intersections on *DC* draw lines to the apex *E*. The elbow in this case is to consist of three pieces

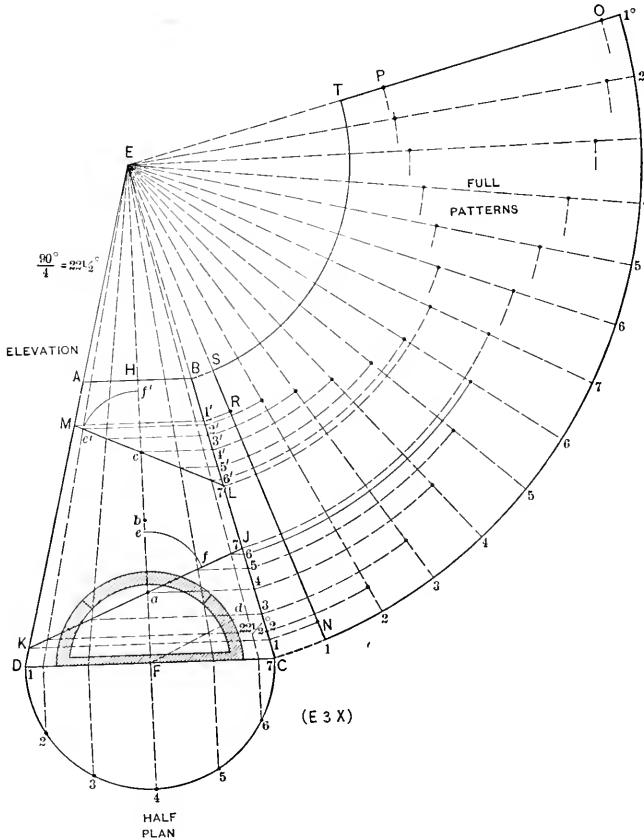

FIG. 129.

with an angle of 90° on its center line when completed. Then following the rule given in Fig. 6, Part One, for obtaining the rise of the miter lines in pieced elbows, we have $22\frac{1}{2}^\circ$ for the rise of the miter line, because 90 divided by 4 equals $22\frac{1}{2}$. Now set the

protractor on the center line in Fig. 129 and draw a line from the center F through $22\frac{1}{2}^\circ$ as shown by Fd . This is all that is required so far as the miter line is concerned. As we do not know the length each piece will have in the throat, the correct length of each piece on its center line can be accurately ascertained as follows: As the end pieces in elbow work count one, and the middle sections two, we have in a three-piece elbow, the number 4. Divide the center line HF in four equal parts as shown by $a-b$ and c . Through a , parallel to Fd , draw the miter line $K\tilde{y}$. In similar manner through c , but in the opposite direction, draw the miter line LM . This miter line LM is obtained by simply transferring the angle as follows: With a as center and any desired radius, draw the arc ef ; again using the same radius, with c as center, draw the arc $f'e'$, making the distance $f'e'$ equal to fe , and draw a line through $e'c$ and extend same either way, until it intersects at M and L . Where the radial lines intersect these miter lines, lines are drawn at right angles to the axis until they intersect the line BC from 1 to 7 and 1' to 7'. The development of the pattern now becomes a simple matter, the principle being similar to that given in Fig. 113. In Fig. 129 $1-N-O-1^\circ$ is then the pattern for the lower section of the elbow; $NRPO$ the pattern for the middle section, and $RSTP$ the pattern for the upper section. When the elbow is completed, it will have the appearance shown in Fig. 130. It should be understood that this rule can only be employed when the elbow

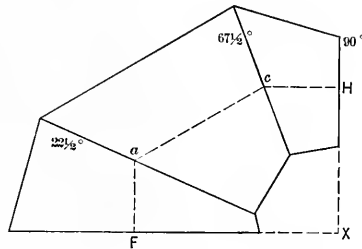

FIG. 130.

has no given dimensions as regards height XH and projection FX . When these dimensions are given, the elbow can only be developed by triangulation, as explained in Fig. 208 in Part Three. Using the same size elevation and plan as in Fig. 129, develop the patterns for a two-pieced elbow whose angle on its center line will be 60° when completed. Also develop the patterns for a four-pieced elbow whose angle will be 90° when completed.

PATTERN FOR OCTAGON SPIRE ON EIGHT GABLES

FIG. 131. Shows the principle to follow when developing the various spires on gables. The problem as presented is an interesting study in projections and contains but little in developments. Let 1 to 8 represent the horizontal section through AB in elevation, in practice the one-quarter plan only being required. Bisect each side in plan as shown by F, E, C, D, G , from which points, and also the corners 1 to 8, draw lines to the center H . Next establish the height of the gables above the line AB in elevation as shown by F^1-G^1 , and from the center of the gables F, E, C, D and G in plan, erect lines intersecting the line F^1G^1 at F^1, E^1, C^1, D^1 and G^1 respectively. In similar manner from points 1 and 2 in plan, erect lines intersecting AB in elevation at $1'$ and $2'$. Connect the gable lines in elevation as shown, these lines representing the extreme upper edge of the mouldings A and B as shown. From A in elevation, which represents the lowest edge of the valley 8- H in plan, draw a line to C^1 in elevation, which represents the highest point of the valley and ridges. The line AC^1 then represents a vertical section of the valley line 8- H in plan, when viewed parallel to 7-8. Establish at will where the lowest point of the spire is to meet the line AC^1 , in this case at a , and draw a line to the apex \mathcal{Y} , cutting the ridge line of the gables at E^1 . Project E^1 of the ridge and a of the valley, cutting the ridge and valley in plan, at e and a' respectively. Using H as center and He and Ha' as radii, intersect the various lines, partly shown by e' and a^x . From e' and a^x , project line vertically cutting the ridge and valley lines at e'' and a° respectively. Draw lines from F^1 to E^1 to e'' to a° to \mathcal{Y} . Complete the opposite side as shown. A line drawn from e'' to a would show the cut of one side of the spire over the gable E in plan, although not necessary in developing the pattern. For the pattern, use \mathcal{Y} as center, and with radii equal to $\mathcal{Y}E^1$ and $\mathcal{Y}a$ describe the arcs shown. Draw any radial line as $L\mathcal{Y}$, intersecting the inner arc at E^2 . On either side of L , perpendicular to $L\mathcal{Y}$, set off La'' equal to $L^\circ a^\circ$ in elevation, and draw lines from a'' to E^2 and \mathcal{Y} . If the whole pattern is desired in one piece, join eight patterns. When the spire is large, the pattern for one side is used, allowing edges for soldering.

FIG. 132. Obtain the pattern for the spire shown in Fig. 132, which is to be square, fitting upon four gables. The bottom of the spire at a and b is to be in a vertical line over the body of the shaft A and B . After obtaining the height of the gable the pattern is obtained by using Dc and Db as radii; da represents the projection in the center of the pattern, at right angle to its center line.

PATTERNS FOR FLARING STRIPS FOR A SPHERE

FIG. 133. When obtaining the flaring strips for a sphere, the method shown in Fig. 133 is applicable to any size or number of pieces, in this case three in the half

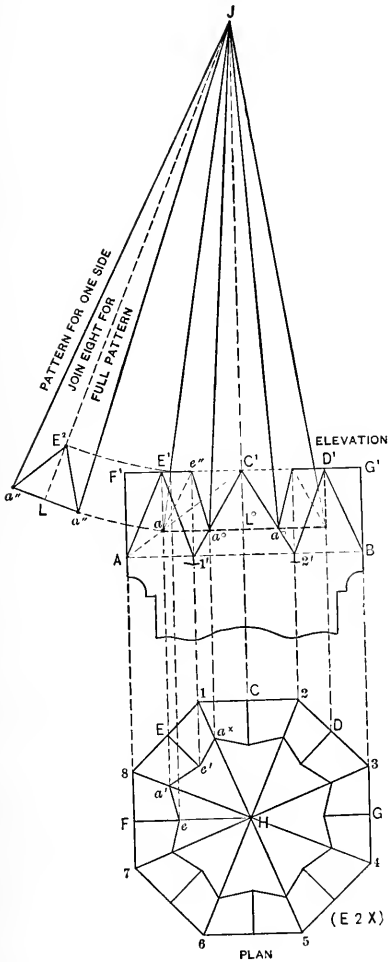

FIG. 131.

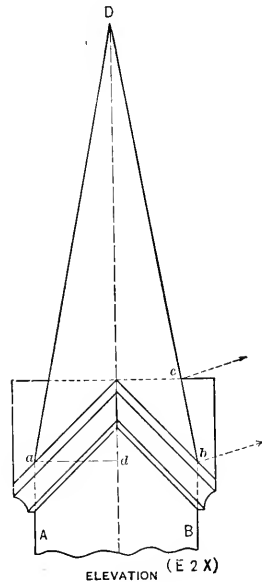

FIG. 132.

sphere. Using *A* as center, describe the circle *BHCN*, and erect the center line *AĴ*. Divide the quarter circle *HC* into equal spaces, and have as many spaces as there are flaring strips in the half sphere, as shown by *D* and *G*. Through these points draw the dotted lines *BC*, *ED* and *FG*. Now applying the same principle used in obtaining the frustum of a right cone, draw lines through *CD* and *DG* until they intersect the center

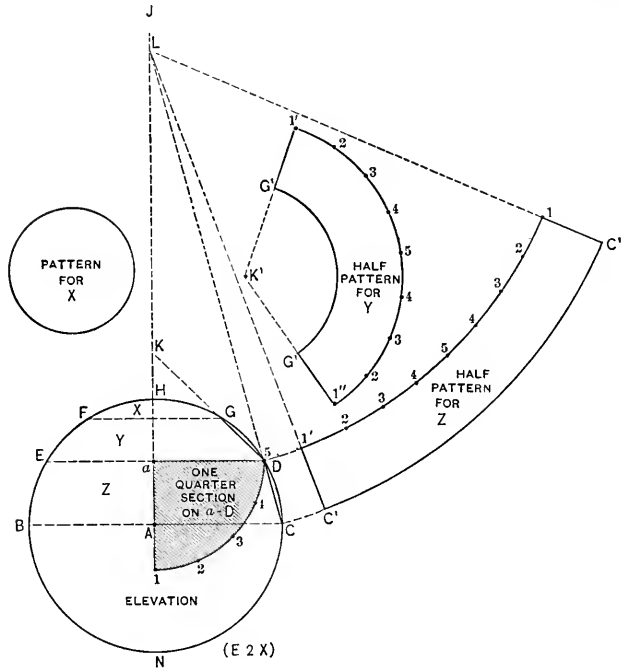

FIG. 133.

line at *L* and *K* respectively. *L* then becomes the center from which to strike the flaring strip for *Z*, and *K* the center for the flaring strip *Y*. As *Z* and *Y* join on the line *ED*, use *a* as center and describe the one-quarter section as shown. Divide this into equal spaces as shown from 1 to 5. Now develop the half pattern for *Z* as shown by 1-C¹-C¹-1'; also the half pattern for *Y*, as shown by 1'-G¹-G¹-1'', using *K*¹ as center, care being taken to place twice the stretchout of the quarter section on the inner curve of the pattern for *Z*, and on the outer curve of the pattern for *Y*. With *HG* as radius, describe the pattern for *X* as shown.

FIG. 134. Obtain the half patterns of the various flaring strips for the shape shown in Fig. 134, the article to be constructed of four pieces as shown by EE' , DD' , aa' and BC . $a-a'$ and $b-b'$ are the centers from which the various outlines are obtained. M is the quarter section on $a'-a$, and N the quarter section on $E'-E$. The various radii with which to strike the flaring strips, are obtained by extending to the center line the lines aC , aD , DE and EA .

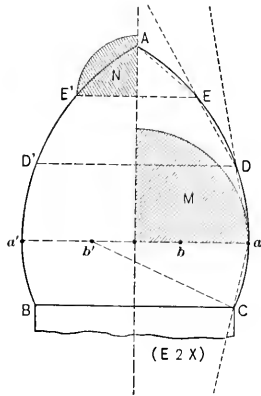

FIG. 134.

PATTERNS FOR FLARING STRIPS FOR CIRCULAR WORK, WHEN MADE BY HAND IN FULL CIRCLES

FIG. 135. In Fig. 135 is shown how to obtain the flaring strip for a cove, having a full circle in plan when completed. A moulding of this kind would require "stretching" along its outer edges C and D , the center portion b remaining stationary. As b represents the stationary point, this point can be used from which to obtain the true length on the flaring strip as in ordinary flaring work. The rule to be observed is as follows: Let $CDD'C'$ be the elevation of the cove to be "stretched" in a full circle in plan, the coves being struck from the centers a and a' . First draw a line from C to D and bisect the cove CD at b . Through b parallel to CD draw the line cd , extending it until it intersects the center line AB at E . Take the stretchout from b to C and from b to D and place it as shown respectively from b to c and from b to d . From b draw the horizontal line $b-e$ and using c as center, describe the quarter circle b_4 , which represents the quarter section on the line cb . Divide this quarter section into equal

spaces as shown. With radii equal to Ed , Eb and Ec , and with E' as center, describe the arcs $d'd''$, $b'b''$ and $c'c''$. Starting from a' on the center line, set off on either side twice the stretchout of the quarter section in elevation, and through b' and b'' in the pattern draw radial lines to the center E' , intersecting the inner and outer arcs at $d'd''$ and $c'c''$, thus completing the full pattern.

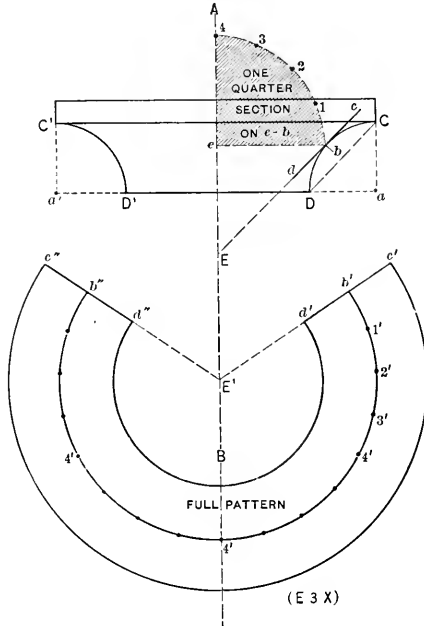

FIG. 135.

FIGS. 136 and 137. These figures illustrate the practical rule for obtaining the flaring strip when the quarter round AB is to be "raised." In this problem the half elevation only is to be drawn. Draw a line from A to B , bisect same and obtain E . From E at right angles to AB draw Ed , which divide into as many spaces as the radius EF contains inches. As any fractional part less than one-half inch is not taken in consideration, and as the distance FE will be $3\frac{3}{4}$ inches, then divide Ed in four spaces as shown, and through the space nearest to the cove as o draw a line parallel to AB , intersecting CD at 5. Take the stretchout from d to A and from d to B and place it as shown from o to a and from o to b . From o draw the horizontal line oe and with e as center and eo as radius, describe the quarter section $o-5$, which then divide into equal spaces as

shown. With radii equal to $5-b$, $5-o$ and $5-a$, and with 5° in Fig. 137 as center describe the arcs as shown by similar reference letters, making the girth along the arc $o-o'$ equal to four times the quarter section on $e-o$ in Fig. 136.

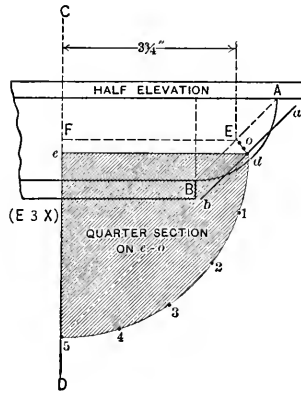

FIG. 136.

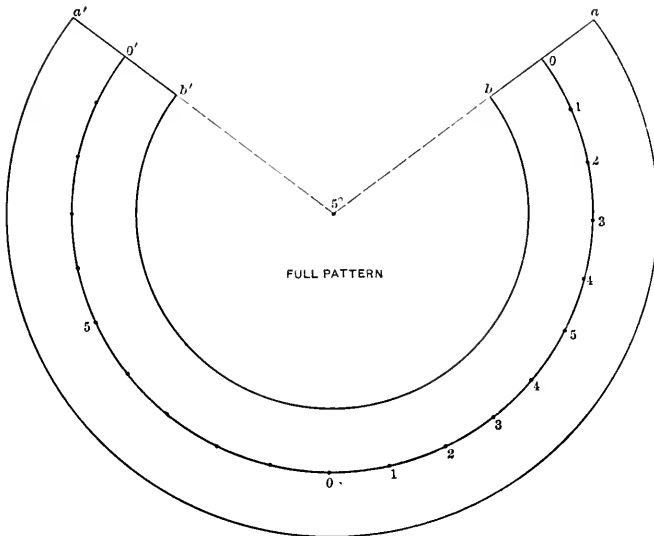

FIG. 137.

FIG. 138. When a flaring strip is desired of an ogee, having a flare in the center, as shown in Fig. 138, the following rule should be used. Draw the half elevation as shown and through the flaring part of the ogee AB , draw the line c_1 , extending it until it intersects the center line CD at D . Take the stretchout from c to A and from 1 to B and place it as shown respectively from c to a and 1 to b . As either 1 or c represents stationary points, take 1 and draw the semi-diameter $1-E$, and using E as center, draw the quarter section $1-6$, which then divide as shown. Next develop the half pattern shown by similar reference letters, being careful to place twice the girth of the quarter section on similar arc $1-1'$ in the pattern as shown.

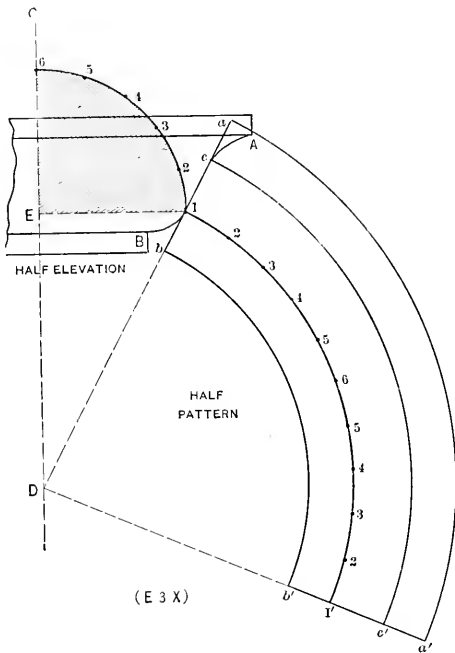

FIG. 138.

FIG. 139. Applying the rules explained in connection with Figs. 135 to 138 inclusive, obtain the flaring strips for the various moulds $A-B-C$ shown in final Fig. 139, each strip to be in one piece.

PATTERNS FOR FLARING STRIPS FOR CIRCULAR WORK, WHEN MADE BY HAND IN ARCS OF CIRCLES

FIG. 140. When obtaining the flaring strips for window caps, circular pediments, etc., where the pattern is laid out in sections equal to 30 or 36 inches, the rule to be

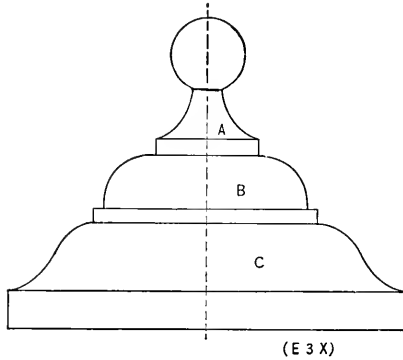

FIG. 139.

used is shown in Fig. 140, in which the elevation of a window cap is shown, with three different profiles on *CA*, as *D*, *E*, and *F*. From *A*, the center from which the arc is struck, draw the horizontal line *AB*. Assuming that the cove *D* is to be used, and requires "stretching," draw a line from *a* to *b*, and parallel to same tangent to the

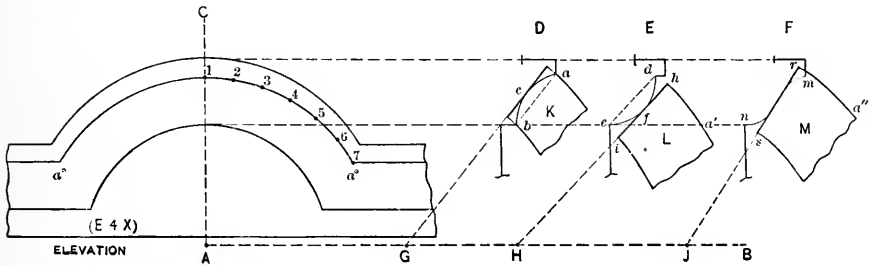

FIG. 140.

curve at *c* draw the line *cG*, intersecting *AB* at *G*. Obtain the stretchout of the cove as given in the preceding problems and as shown by the solid line *c*. Then with *G* as center, the blank or pattern *K* is obtained. The amount of material required can be measured along the arc $a^{\circ}-a^{\circ}$ and placed on the outer curve *a* in the pattern *K*,

PATTERN FOR FLARING STRIP FOR CIRCULAR WORK, WHEN MADE BY MACHINE

FIG. 143. Shows the rule employed when obtaining the flaring strip for machine work. Let $ABCD$ represent part elevation of a moulding running around the corner of a building as shown by $EFGH$ in plan, the arc being struck from the center J

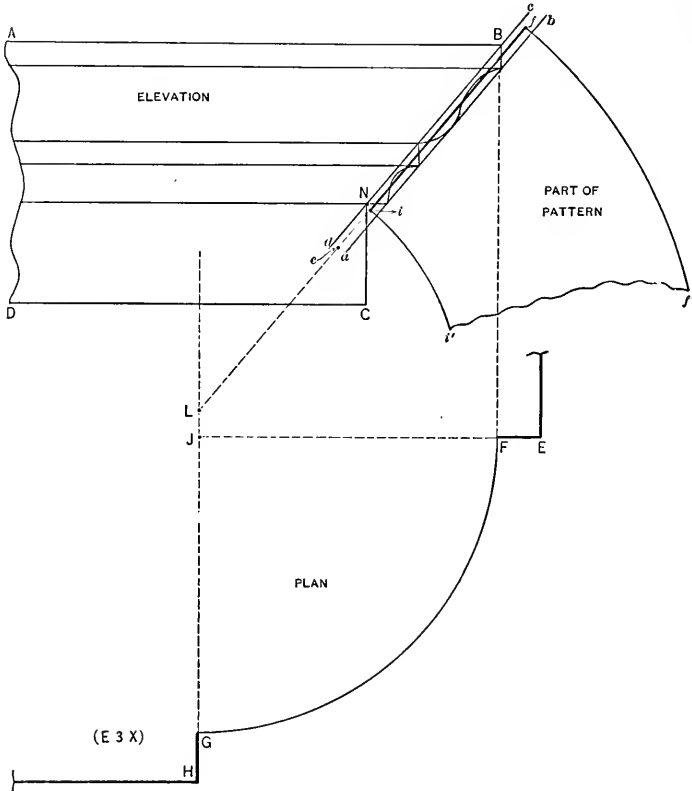

FIG. 143.

Above F , as shown, draw the profile BN and through the outer extreme points draw the line $a-b$; also through the inner extreme points draw dc . Bisect the distance da and cb and obtain e and f . Through f and e draw a line, extending it until the ver-

tical line drawn through the center point \mathcal{F} in plan, is met at L . Then L becomes the center from which to strike the pattern. Starting at the lowest point of the moulding as i , obtain the stretchout of NB and place it as shown from i to j . Using L as center the part pattern $jj'i$ is struck. The length can be measured along FG in plan and placed on jj' in the pattern. It should be understood that in obtaining the length of FG , allowance must be made on jj' , because when passing the flaring strip through the dies in the machine, the ends have a tendency to round more than is called for. By having more material, the ends are cut as required, to make a miter joint with EF and GH in plan.

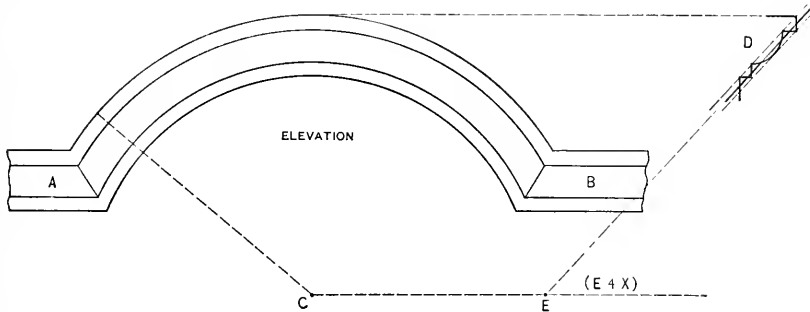

FIG. 144.

FIG. 144. Shows part elevation of a circular pediment by AB , C being the center point. D is the section of the mould and E the center for the pattern. Using the same rule given in previous problem, obtain the part pattern for the flaring strip.

and 5". From these intersections, horizontal lines are drawn, which are intersected by vertical lines, drawn from similar numbers in the profile of the cylinder in plan, resulting in the intersections 1° to 5° in elevation. From 1° and 5° erect the vertical lines 1°*F* and 5°*G*, which connect from *F* to *G*. Then 1°-5° shows the miter line between the cylinder and cone. The pattern for the cylinder is obtained by Parallel Line Developments as in Part One. The stretchout of *a* in plan is placed on *H* \bar{y} , and the pattern obtained as shown by *H* \bar{y} *P*. As the pattern for obtaining the cone is similar in process to Fig. 112, we will only describe in Fig. 145 the method for obtaining the opening in the cone. With *A* as center and radii equal to *A*-5", *A*-4", *A*-3", *A*-2" and *A*-1", describe short arcs as shown. At pleasure draw the center line *Ab*. Then measuring, in each instance, from the center line *DE* in plan, take the various distances along the arcs to points 2, 3 and 4 and place them on similar arcs in the pattern, measuring on either side of the line *Ab*, thus obtaining points 1^x to 5^x. The shaded portion is the desired opening. Using the same size plan and elevation as in Fig. 145, obtain the necessary patterns, when the pipe is square, and placed diagonally as in Diagram *X*; also when the pipe has semi-circular ends as in Diagram *Y*. In working out these problems, the points *a'*, *e'* in *X* and *a''*, *e''* in *Y*, should be placed over *a* and *e* in plan.

PATTERNS REQUIRED FOR INTERSECTION BETWEEN CONE AND CYLINDER PLACED HORIZONTALLY

FIG. 146. The principles in Fig. 145 are also applicable to the problem given in Fig. 146. Draw the elevation *ABC* and the plan view *D*. In its proper position in elevation draw the cylinder *E*-3°-3°-*F*, also its profile shown by *H*, which divide into equal spaces shown from 1 to 5 to 1. Through these points draw horizontal lines, intersecting *AC* as shown. From these intersections drop vertical lines intersecting *cb* in plan at 2-4, 1-5 and 2-4. Using *a* as center, draw the circles shown. On the center line *bc* extended, place a tracing of *H*, as shown by *H*¹, giving the circle a quarter turn, bringing point 1 to the top. From these intersections horizontal lines are drawn, intersecting circles having similar numbers, as shown by 1' to 5' to 1'. From these intersections vertical lines are erected, intersecting similar planes in elevation as shown from 1° to 5°. A line traced through these points gives the miter line between the cylinder and cone, which, however, is not necessary in developing the pattern for the cylinder, because the pattern could be obtained from the intersections in plan as well as from the elevation. The pattern for the cylinder is obtained in the usual manner. The opening in the cone is obtained in the manner explained in Fig. 145, being careful to take the distances along the arcs in plan in Fig. 146, measuring on either side of the center line *bc*, and placing them on similar arcs in the pattern measuring on either side

of Ab' . Making drawing similar in size to that in Fig. 146, develop the patterns required when the section of the pipe is square, as shown by the dotted lines inside of

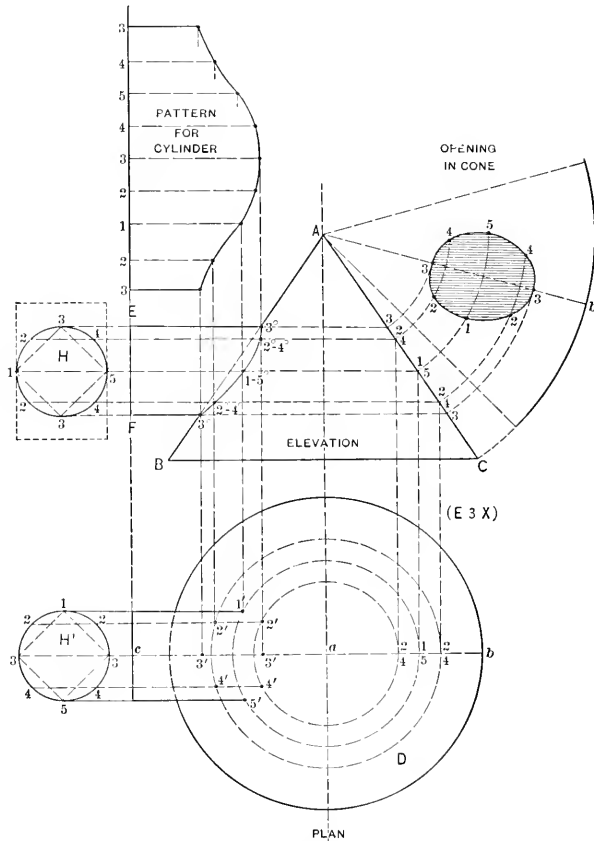

FIG. 146.

the circle H , also when the pipe is rectangular and is placed in a position shown by dotted lines outside of the circle.

PATTERNS REQUIRED FOR INTERSECTION BETWEEN CONE AND RECTANGULAR PIPE PLACED HORIZONTALLY, TO ONE SIDE OF THE CENTER OF THE CONE

FIG. 147. The principle in this problem, Fig. 147, does not differ from that given in Fig. 146, except in placing the horizontal pipes. In Fig. 146 the side view of the pipe is shown, while in Fig. 147 the end view is shown. We will assume that a rectangular pipe, $2-2^x-5^x-5$, is to join a cone, so that the corner 2^x will meet the side of the cone as shown. Divide 2^x-5^x into any convenient number of parts and draw the horizontal

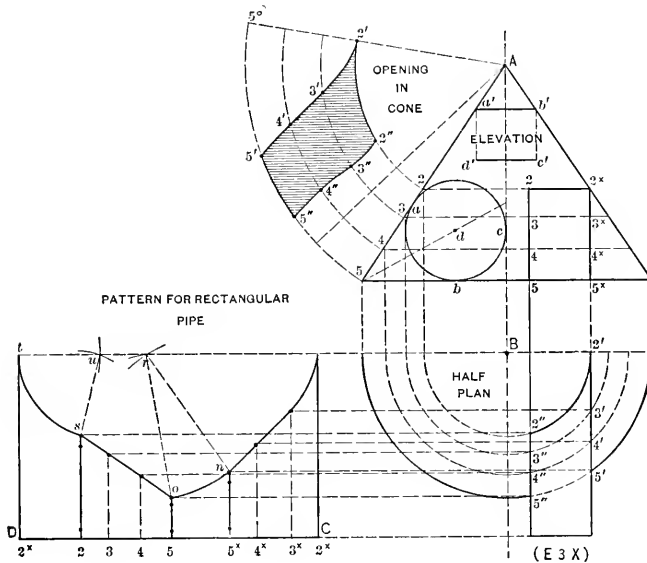

FIG. 147.

planes through 2^x , 3^x , 4^x and 5^x , cutting the side of the cone as shown by 2-3-4-5. Draw the half plan on the various planes as shown, and complete the plan view of the pipe, cutting various planes in plan at $2'$ to $5'$ and $2''$ to $5''$. The pattern for the rectangular pipe is obtained in the usual manner, placing the stretchout of the rectangular pipe on DC , drawing the customary measuring lines, and intersecting same by lines drawn from similar numbers in plan. The radii from which the arcs $n-o$ and st in the pattern are struck are obtained respectively from $B-5'$ and $B-2'$ in plan, using r and u as center points in the pattern. For the opening in the cone, draw any radial line as $A-5^\circ$. With

A as center and radii equal to $A-2$, $A-3$, $A-4$ and $A-5$, draw arcs as shown. Now measuring in each case from the line $B-2'$ in plan, take the various distances along the various arcs, to points $2'-2''$, $3'-3''$, $4'-4''$ and $5'-5''$ and place them on similar arcs in the pattern as shown by similar numbers, the shaded portion being the opening required. Applying the same principles as in Fig. 147, develop the patterns when the cylinder $a-b-c$ is tangent at $a-b$ and c . Also obtain the patterns when the rectangular pipe $a'b'c'd'$ is placed in the center of the cone, the two corners a' and b' touching the sides of the cone as shown. The patterns for the intersections between the pipe $a'b'c'd'$ and the cone could be obtained as in Fig. 146, but is introduced in Fig. 147 to show how it can be developed by placing the pipe in end view. It should be understood that the method shown in Fig. 146 can be used when the pipe comes centrally over the center line of the cone. But when the pipe intersects to one side of the center line, Fig. 147 presents the operations more clearly.

PATTERNS REQUIRED FOR INTERSECTION BETWEEN CYLINDER AND CONE AT OTHER THAN RIGHT ANGLES

FIG. 148. The principles illustrated in Fig. 148 for obtaining the intersections between a round pipe placed to one side of the cone at an angle in elevation, is applicable to any size cone or pipe, whether the pipe is round, square or elliptical and placed to one side or over the center of the cone. This problem presents an interesting study in projections and should be closely followed. Draw the center line AB , on either side of which place the half elevation of the cone as GCF . Using H as center draw the quarter plan 9-13. Divide this quarter circle into equal spaces, as shown by the small figures 9, 10, 11, 12 and 13, from which points draw radial lines to the center H . From these figures erect lines, cutting the base of the cone at $9'-10'-11'-12'$ and $13'$, from which draw radial lines to the apex C . At the proper distance above F on the line FE , draw the elevation of the cylinder, also its section d , which divide into equal spaces as shown from 1 to 8, through which points parallel to the lines of the pipe draw the various planes, cutting the radial lines in elevation, also the center line AB and the base line GF as shown. It now becomes necessary to obtain in plan the different horizontal sections on the various planes in elevation. For example, where the plane 1- e in elevation crosses the various radial lines, drop vertical lines to the plan intersecting similar numbered radial lines as shown, and take the horizontal distance from e to e' in elevation and place it as shown from H to 1 in plan. The curved line 1-1 in plan then represents the horizontal section on the plane 1- e in elevation. Obtaining the other sections in the same manner, 2-8, 3-7, 4-6 and 5-5 in plan represent respectively the horizontal sections on the planes, f -2-8, 3-7, 4-6 and 5 in elevation. Having established these sections in plan, the next step is to locate the position where the side of the

pipe 3 in d' in plan, is to meet the cone (in this case at $3'$) on the section 3-7, representing the plane 3-7 in elevation. This point being established, take a tracing of d and place it in the position shown by d' . Through the various figures in d' , draw horizontal lines cutting similar numbered sections, as shown by intersection $1'$ to $8'$. From these intersections vertical lines are erected, intersecting similar numbered planes in elevation as shown from $1''$ to $8''$. For the pattern of the opening in the cone pro-

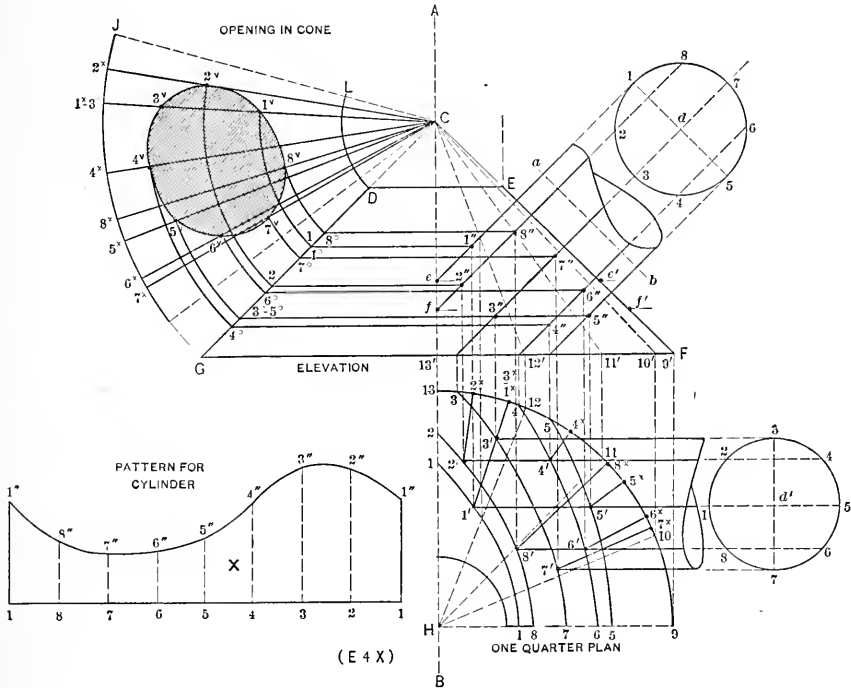

FIG. 148.

ceed as follows: Through the various intersections $1'$ to $8'$ in plan, draw radial lines from the center H , intersecting the quarter circle 9-13 from 1^x to 8^x as shown. Also from the various intersections $1''$ to $8''$ in elevation draw horizontal lines, cutting the side of the cone CG , from 1^o to 8^o . With C as center and radii equal to CG and CD , draw the arcs $G\tilde{y}$ and DL . Next take the various divisions in plan from 7^x to 6^x to 5^x to 8^x to 4^x to 1^x3^x to 2^x and place them on the arc $G\tilde{y}$, as shown by similar numbers, and draw lines to the apex C . Using C as center with radii equal to the various divisions between 4^o and 8^o , draw arcs, intersecting similar radial lines in the pattern, as shown

from 1^v to 8^v. Trace a curved line through these points, then will the shaded part be the desired opening. The pattern for the cylinder in *X* is obtained in the usual manner. A stretchout of *d* is placed on the line 1-1 in *X*, measuring lines erected and the various distances taken from the line *a-b* to points 1" to 8", and placed on similar lines in *X*, as shown by similar numbers.

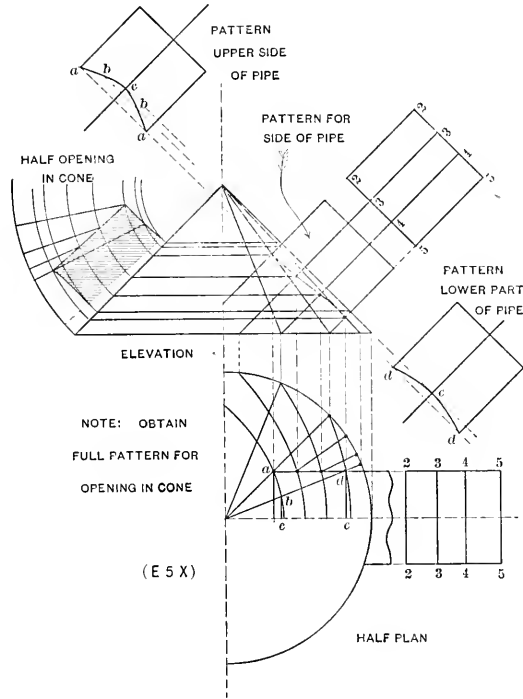

Fig. 149.

FIG. 149. Using the principle in Fig. 148, obtain the patterns for the intersection between a square pipe and cone, the square pipe to be placed in the center of the cone, as shown in plan in Fig. 149. 2-2-5-5 is the profile of the square pipe, through which various planes are drawn as shown. The sections through the various planes are shown in plan, also the various points of intersections. The various patterns are also shown minus the reference letters. By carefully studying the diagram the student should have no difficulty in solving the problem.

PATTERNS REQUIRED FOR CONE INTERSECTING CYLINDER AT AN ANGLE OF FORTY-FIVE DEGREES

FIG. 150. The principles given in Fig. 150 for obtaining the intersection and developments between a cylinder and cone, can be applied to any problem, no matter what the angle may be; whether the vertical pipe is round, square or rectangular or whether the cone is placed in the center or to one side of the pipe. In this problem first draw the elevation of the round pipe *BCDE*, and below same the plan view, struck

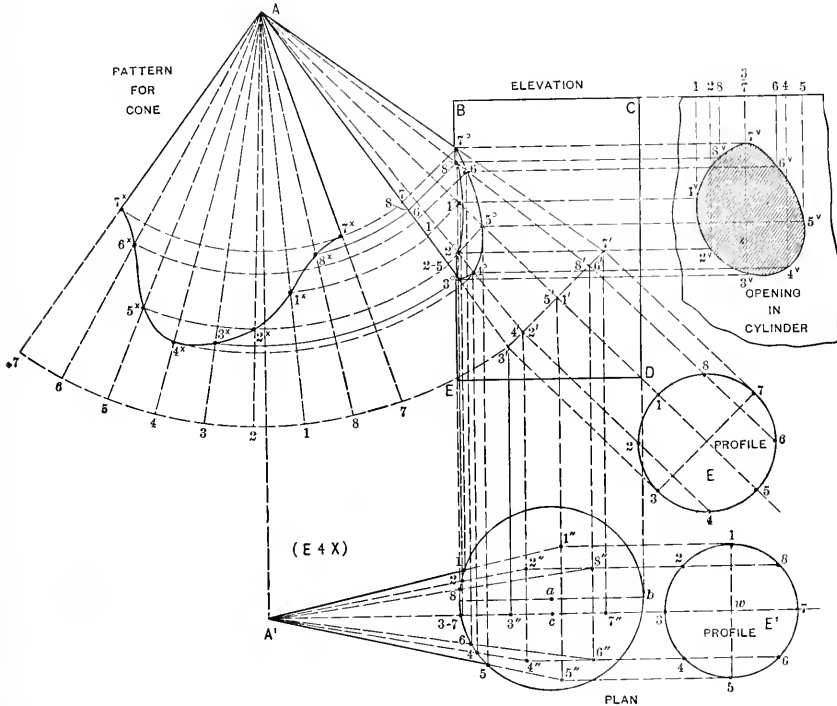

Fig. 150.

from the center *a*. In its proper position in elevation draw the cone *A-7°-3°*, extending the sides of the cone equally until a convenient base line *3'-7'* is obtained. Below this line draw the profile *E* of the cone as shown, which divide into equal spaces 1 to 8. From these points, parallel to the center line of the cone, erect lines, cutting the base line of the cone from *1'* to *7'*, from which points radial lines are drawn to the apex *A*.

In this problem the center line of the cone in plan is to be placed to one side of the center line of the cylinder, the distance to be as is indicated from a to c . Therefore, through c parallel to ab , draw the line $7A^1$, and from A in elevation drop a vertical line, intersecting this line at A^1 . With w as center, draw the profile E^1 , which is a duplicate of E , and change the position of the small figures as shown in E^1 . From the points 1 to 8 in E^1 draw horizontal lines, which intersect by vertical lines dropped from similar intersections on $3'-7'$ in elevation, resulting in the points of intersections in plan shown from $1''$ to $8''$. From these intersections draw lines to the apex A^1 , crossing the plan of the cylinder from 1 to 8. From the intersections 1 to 8, vertical lines are erected, intersecting similar numbered radial lines in elevation as shown from 1° to 7° . A line

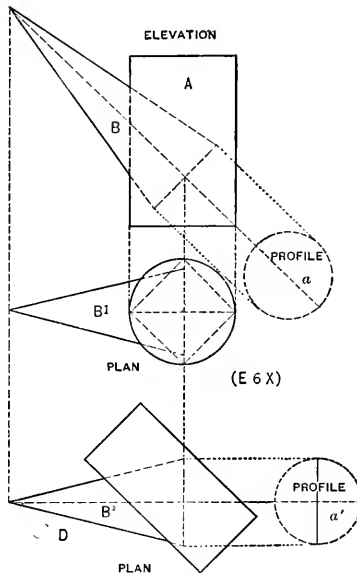

FIG. 151.

traced through these points as shown, gives the line of intersection. From the various intersections 1° to 7° at right angle to the axis of the cone, draw lines until they intersect the side of the cone from 1 to 8. For the pattern of the cone, use A as center, and with $A-3'$ as radius, describe the arc $7-7'$. On this arc lay off the stretchout of the profile E . As the seam is desired at $A-7^\circ$ in elevation, then start at 7 on the arc $7-7'$,

as shown from 7 to 8 to 1 to 2, etc. From these figures draw radial lines to A , which intersect by arcs drawn from similar numbers on $A-3'$ with radii equal to the various divisions, resulting in the intersections 7^x to 7^8 in the pattern. $7^x 4^x 7^8 A$ is the desired pattern. The pattern for the opening in the cylinder is obtained by taking the stretch-out of the various intersections in plan and placing them on the line BC extended, as shown by similar numbers. Vertical lines are now drawn, and intersected by horizontal lines from similar numbers in the miter line in elevation, giving the intersections 1^v to 8^v in the pattern. The shaded portion shows the desired opening. When enlarging this problem, the profiles E and E^1 should be divided into twelve spaces.

FIG. 151. Using the principles in Fig. 150, solve in Fig. 151 the intersection between the cone B with the cylinder A , when the cone is placed in the center of the cylinder as shown in plan by B^1 . The profile of the cone is shown by a . Also obtain the patterns when the cone intersects a vertical square pipe, as shown by the dotted square in plan. D represents the plan view of a cone intersecting the side of a rectangular pipe placed diagonally in plan, a' representing the profile of the cone. Patterns for these two pieces are also to be developed.

PATTERNS REQUIRED FOR INTERSECTION BETWEEN TAPERING SQUARE PIPE, AND VERTICAL SQUARE PIPE, PLACED DIAGONALLY

FIG. 152. In this figure $ABCD$ represents the plan view of a square pipe placed diagonally, intersected by a tapering pipe as shown in plan and elevation. The principles in this problem are similar to those in Fig. 150. E in Fig. 152 is the elevation of the square pipe; F , 1-2, 3-4, the elevation of the square tapering pipe, extended to an apex F , and a^x the section on the base line a . From the intersections 1-2 and 3-4 on the base line a , lines are projected into the plan, and the intersections $1'-2'$ and $3'-4'$ obtained by taking the distances from a to 1-2 and a to 3-4 in elevation and placing them in plan as shown from a' to $1'$ and $2'$ and from a'' to $3'$ and $4'$. From these points radial lines are drawn to F^1 , cutting ABC of the square pipe from $1''$ to $4''$. From these intersections lines are erected cutting similar radial lines in elevation as shown from 1^o to 4^o . It will be noticed that the centers of the top and bottom of the tapering pipe intersect the corner of the vertical pipe in plan at B , shown in elevation by B^1 and B^2 . Before the pattern for the tapering pipe can be developed, the true radii must be found as follows: Equal in length and parallel to Fa , draw de . Take the distance of the diagonal $a^x 1'$ and place it as shown from e to a^v and draw $a^v d$. At right angle to Fa and from the various intersections 1^o-2^o , 3^o-4^o and b draw lines intersecting $a^v d$ at 1^o-2^o , 3^o-4^o and b . With d as center and da^v as radius, draw the arc 1-1, on which lay off the girth of a^x and draw radial lines to d as shown. Bisect 1-2 and 3-4

in the pattern and obtain B and B' , which represents respectively the center lines of the upper and lower sides of the tapering pipe. With d as center and radii equal to $d-b$, $d-1^{\circ}2^{\circ}$ and $d-3^{\circ}4^{\circ}$, draw arcs intersecting similar radial lines in the pattern as shown. Take the distances of fB' , the center length of the upper side of the pipe and bB' , the center length of the lower side of the pipe, and place them in the pattern as shown respectively by fB' and bB' . Connect the various points as shown by the heavy lines, which gives the desired pattern. The opening to be cut in the square pipe is shown shaded and is obtained by taking the girth of $4''-1''-B-2''-3''$ in plan, and plac-

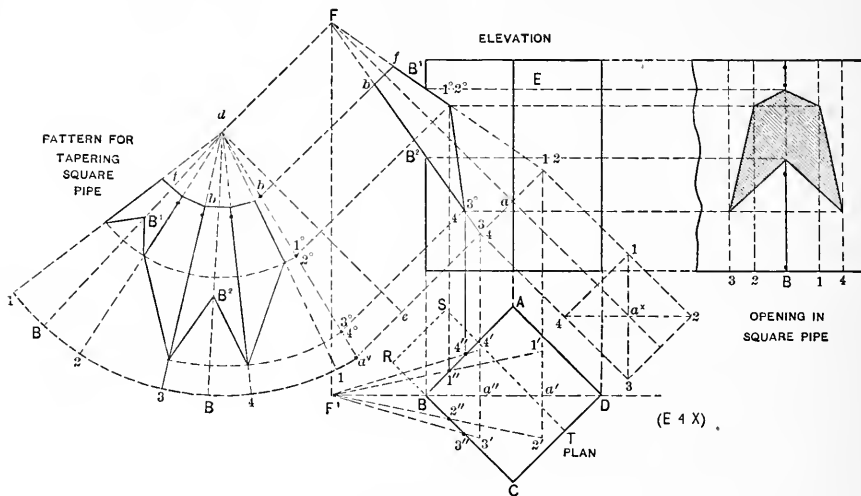

FIG. 152.

ing it on the lower line in elevation extended, as shown by similar numbers, from which vertical lines are erected and intersected by horizontal lines drawn from similar numbers in the miter line in elevation. Obtain the patterns required when the tapering pipe in Fig. 152 intersects the side of a rectangular pipe placed in the position in plan as shown by $RSTC$. The angle of the tapering pipe in elevation is to be similar as shown in the preceding problem.

PATTERNS REQUIRED FOR INTERSECTION BETWEEN TWO CONES OF UNEQUAL DIAMETERS

FIG. 153. The principles in this problem are similar to those given in Fig. 148. First draw the elevation of the cone as ABC in Fig. 153 and in its proper position below

same place the plan view *D*. Divide the quarter plan 1-3 into equal spaces (in this case two) as shown by the figures 1-2-3, and draw radial lines to *A*' as shown. In

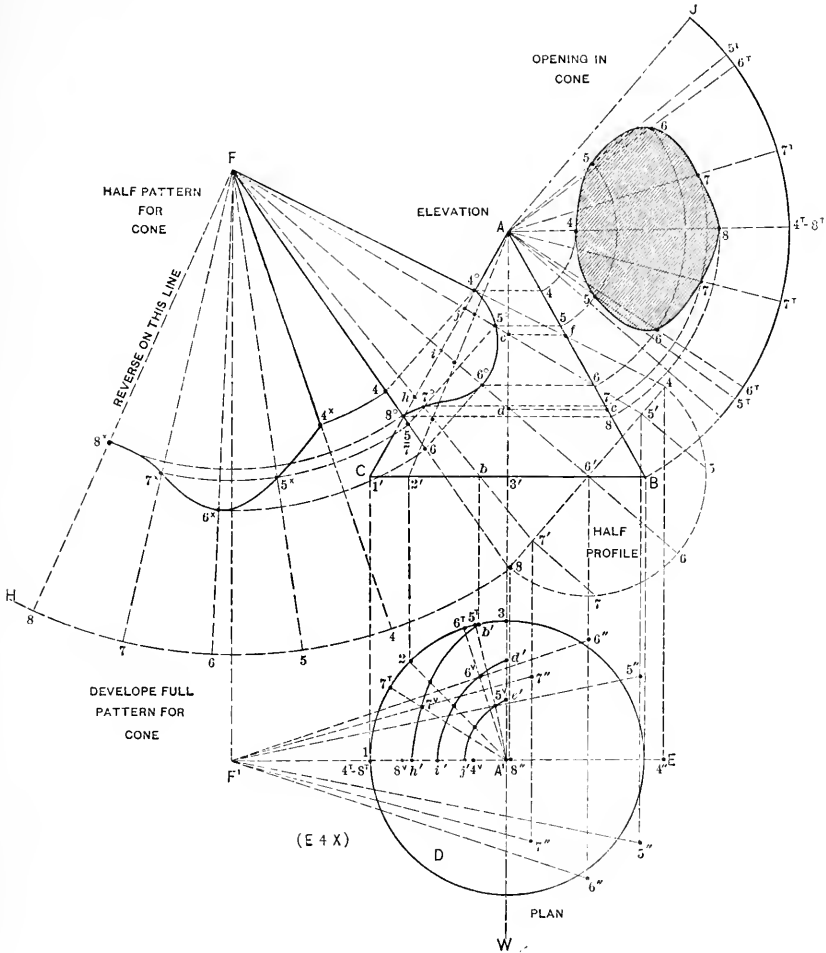

FIG. 153.

enlarging this problem a larger number of divisions should be used in the quarter plan *D* and the half profile 4-6-8. From the intersections 1, 2 and 3 in plan, erect lines cut-

ting the base line CB at $1'-2'$ and $3'$, from which radial lines are drawn to the apex A . In its proper position draw the elevation of the intersecting cone, as shown by F , $4^\circ-8^\circ$. Extend each side equally any convenient distance, as shown by F_4 and F_8 . Draw the line $4-8$, bisect same, and obtain $6'$, which use as center and draw the semi-circle $4-6-8$. Divide this into equal parts, shown from 4 to 8 , from which points perpendicular to $4-8$, erect lines cutting $4-8$ at $5'-6'$ and $7'$. From these points draw radial lines to F , intersecting the radial lines in the cone ABC as shown. The next step is to obtain the horizontal views of the cone ABC on the planes $F-5'$, $F-6'$ and $F-7'$. As the cones intersect each other center on center, then 4° and 8° in elevation will meet the center line in plan at 4^v and 8^v . Where the plane $F-7'$ crosses the radial lines drawn from $1'$ and $2'$ and the base line at b , lines are projected into the plan (not shown) until they intersect similar radial lines 1 and 2 , also the plan of the base at b' . $b'h'$ is then the horizontal section through the plane bh in elevation. In similar manner obtain the horizontal sections through the planes id and je , as shown in plan by $i'd'$ and $j'e'$, the distances from A^1 to e' and A^1 to d' being obtained from e to f and d to c respectively in elevation. The next step is to find where the various planes in the intersecting cone $F_4^\circ 8^\circ$ cut the horizontal sections in plan. This is done by dropping lines from the points 4 , $5'$, $6'$, $7'$ and 8 into the plan as shown, making the distances $5''$, $6''$ and $7''$, measuring from the center line F^1E , equal to the distance 5 , 6 and 7 in the half profile measuring from the line $4-8$. Thus a line drawn from $5''$ to F^1 in plan cuts the section $e'j'$ at 5^v ; a line drawn from $6''$ cuts the section $d'i'$ at 6^v and a line from $7''$ cuts the section $b'h'$ at 7^v . Now, from the intersections 4^v , 5^v , 6^v , 7^v and 8^v erect lines intersecting similar radial lines in elevation at 4° , 5° , 6° , 7° and 8° as shown. From these intersections at right angle to the axis $F-6'$ and $A-3'$ draw lines intersecting respectively the sides of the cones at $F-8$ and $A-B$ as shown by similar numbers. For the pattern of the cone (only one-half shown), use F as center and $F-8$ as radius and describe the arc $8-H$, upon which place the girth of the half profile and draw radial lines to F , which intersect by arcs, drawn from F as center and radii equal to the divisions 4 to 8° on the line $F-8$, resulting in the intersections 4^x to 8^x in the half pattern. Through the various intersections 4^v to 8^v in plan, draw radial lines from the center A^1 , intersecting the circle at 4^r-8^r , 7^r , 6^r and 5^r . To get the opening to be cut in cone, use A as center and with AB as radius describe the arc $B\check{y}$. Draw any line as $A-4^r 8^r$ on either side of which place the stretchout of the spaces designated by T in the plan as shown on the arc $B\check{y}$. Draw radial lines as shown, which intersect by arcs drawn from A as center with radii equal to the divisions between 4 and 8 on AB , resulting in points of intersections 4 to 8 in the pattern which is shown shaded.

FIG. 154. Solve this problem in which two cones intersect, both axis being parallel, using the principles explained in Fig. 145. The outlines of the cones in Fig. 154 are first drawn as shown by ABC and CDE . The space between the intersections 1^x and 4^x

is divided into any convenient number of parts as shown by 2 and 3 and horizontal planes 1-1, 2-2, 3-3 and 4-4 drawn through both cones. Show the horizontal sections in plan, through the planes 1, 2, 3 and 4 in the cone *ABC*, as indicated from 1° to 4°,

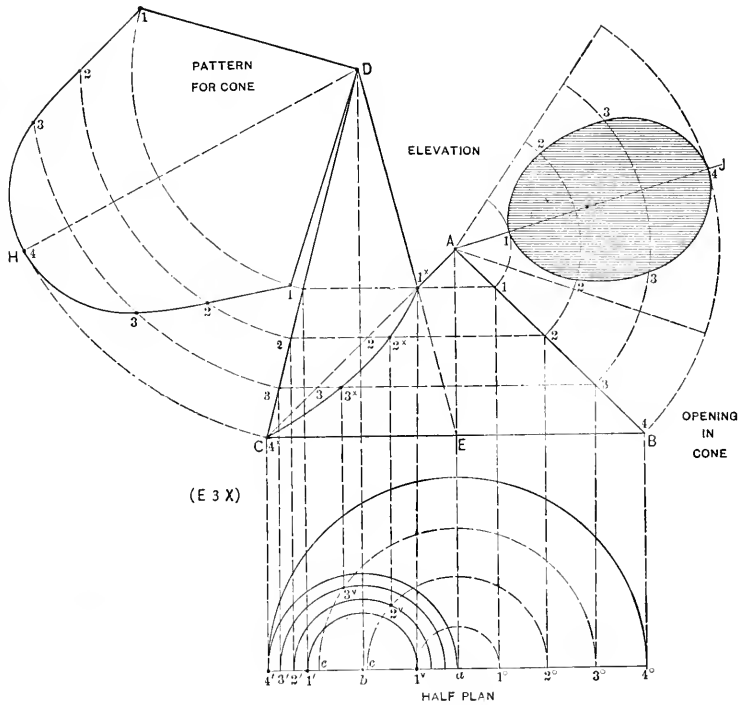

FIG. 154

using *a* as center. In similar manner show the sections through the planes in the cone *CDE* indicated in plan from 1' to 4' struck from the center *b*. Where similar numbered semi-circles intersect as at 1^v, 2^v, 3^v and 4', lines are erected, intersecting similar planes in elevation as shown from 1^x to 4^x. Now, with *D* as center and with radii equal to *D1*, 2, 3 and 4^x, describe arcs as shown. At pleasure draw *DH*. Obtain the girth in plan of 3' to 3^v, 2' to 2^v and 1' to 1^v and place it on either side of the center line *DH* in the pattern, on arcs having similar numbers, thus obtaining the points of intersections 1 to 4, the heavy line showing the full pattern. For the opening in the cone draw the arcs as shown, and take any center line as *AĴ*. Obtain the girth of

c to 2^v and e to 3^v and place it on similar numbered arcs in the pattern, as shown from 1 to 4 on either side. Then will the shaded portion be the desired pattern. This same principle is applied no matter what size cones or frustums are used.

PART THREE—THE PRINCIPLES OF TRIANGULATION AS APPLIED TO DEVELOPMENTS OF IRREGULAR FORMS

There are numerous irregular forms arising in sheet metal work, the patterns for which cannot be obtained either by parallel or by radial line developments. While possessing straight lines, these lines are not parallel, nor do they run to a common center. In working out patterns of this character, it becomes necessary, first of all, to divide the drawing representing the surface of the article into triangles. Then from the drawing, the true lengths of the various sides must be found, and the triangles constructed therefrom. This is the basis of Triangulation. After the length of each side is known, it becomes a simple problem in geometry to construct the triangle, as illustrated in Fig. 155. In this figure, $a-b$, $b'-c$, and $c'-a'$ are the given lengths from which to construct the triangle $a-b-c$. In the problems that follow, two methods of developing the pattern are shown, *viz.*, with and without the aid of a plan. Understanding both methods, the student will be in a position to apply, in practice, the one best suited to the work in hand.

PATTERN FOR TRANSITION PIECE, RECTANGULAR TO SQUARE

FIGS. 156 and 157. While irregular forms are largely curved surfaces, we can at the outset best illustrate development by triangulation by using a solid having plane surfaces, as shown in Fig. 156, in which $ABCD$ is the plan of the rectangular base, and $EFH\checkmark$ the plan of the square top, each side of which shows its true length. From the corners in the square plan draw lines to the corners in the rectangular plan, as shown. These lines then represent the bends which must be made in the article so as to form the transition piece, and also represents the bases of the triangles, which must be constructed so as to find the true lengths of these lines. Knowing that the attitude is equal to LM in elevation the triangles are constructed as follows: Draw any horizontal line as aE and from a , erect the perpendicular $a-b$ equal to the altitude of the article LM . As the square $FE\checkmark H$ is placed directly in the center of the rectangle, then all that is necessary is to find the true lengths of EB and $\checkmark B$. Take these two distances and place them as shown from a to E and a to \checkmark , and draw the lines $\checkmark b$ and Eb , which represent respectively the true lengths of the lines $\checkmark B$ and EB in plan. As-

sume that the pattern is to be laid out in one piece, with a seam through *NE* in plan. Take this distance *NE* and place it as shown from *a* to *N*, and draw a line from *N* to *b*, which will be the true length on *NE* in plan. Having found the true lengths of all the lines in plan, it only remains to place the various triangles in position in the pattern by using the same method as explained in connection with Fig. 155. Draw

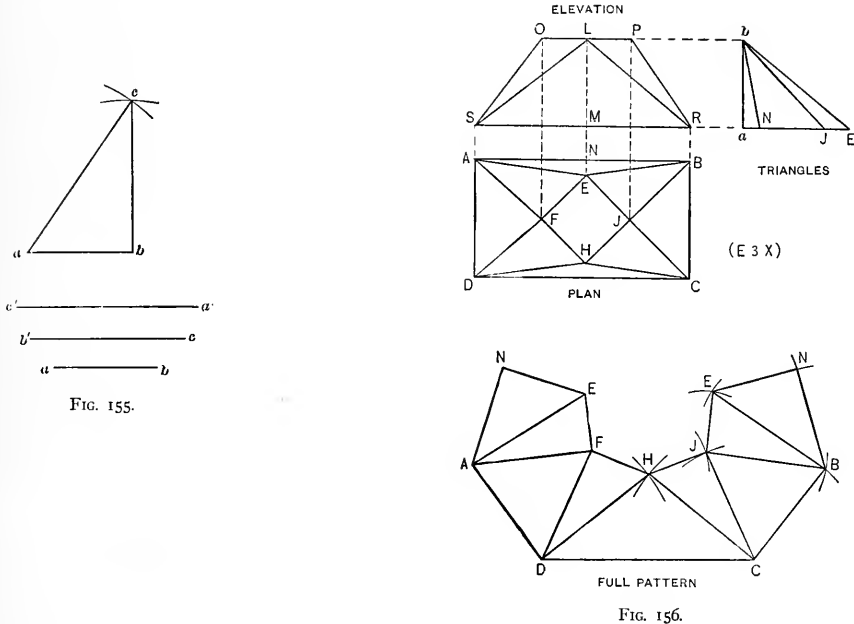

FIG. 155.

FIG. 156.

any horizontal line as *DC* in the pattern in Fig. 156, equal to *DC* in plan. Now with radius equal to *bE* in the triangles, and *D* and *C* in the pattern as centers, describe arcs intersecting each other at *H*. Draw lines from *D* to *H* and *H* to *C*. Then *DHC* is the pattern for *DHC* or *AEB* in the plan. With *H* as radius, and *H* in the pattern as center, describe the arc *h*, which intersect by an arc, struck from *C* as center, and *h* in the triangles as radius. Draw a line from *H* to *h* to *C* in the pattern. Then *HhC* is the pattern for either *HhC*, *hEB*, *EFA* or *FHD* in the plan. With *h* as radius and *h* in the pattern as center, describe the arc *B*, which intersect by an arc struck from *C* as center and *CB* in plan as radius. Draw a line from *h* to *B* to *C* in the pattern, which is the pattern for the sides *hBC* and *FAD* in plan. *hEB* in the pattern is the reverse of *hHC*. Now, with radius equal to *BN* in plan, and *B* in the pattern as center, draw the arc *N*, which intersect by an arc struck from

E as center and bN in the triangles as radius. Draw the lines E to N to B in the pattern which is the development of either ENB or ENA in plan. Take a tracing of $ENCH$ in the pattern, and place it opposite the line HD and obtain the full pattern. This same pattern can be obtained by another method wherein the plan view is dispensed with. It is important to remember that the method which follows, can only be employed when both halves of the article to be developed are symmetrical, as shown in Fig. 157 by A and B , in which $a-b$ and $c-d$ are the center lines. If the article is not symmetrical as in plan C in Fig. 157, then the method just gone through must be employed.

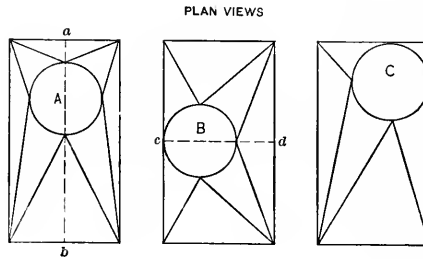

FIG. 157.

FIG. 158. To prove the second method and to show that the true lengths of the various lines will result alike in both methods, Fig. 158 is given, in which $OPRS$ is a reproduction of $OPRS$ in Fig. 156. Take the half profiles of the top and bottom in plan and place them as shown, shaded by OEP and $SDCR$ in Fig. 158. From E draw the vertical line Ea , and from a draw lines to S and R . Then will these lines in elevation become the base lines, and the vertical heights in the profiles, the attitudes of the triangles, which will be constructed as follows: Take the distances PR and Ra and place them on any horizontal line as P^1R^1 and R^1a^1 . Make the distance a^1E^1 and R^1C^1 equal respectively to aE and RC and draw lines from E^1 to R^1 and C^1 to P^1 representing respectively the true lengths of aR and RP in elevation, and being equal to similar true lengths Eb and $\bar{y}b$ in Fig. 156. To find the true length of the seam line $a-b$ in Fig. 158 place it on a^1-b^1 and make a^1E^1 and b^1C^1 equal to aE and RC . Then will the distance E^1C^1 be the true length on $a-b$ and equal in length to Nb in Fig. 156. Having found the true lengths in Fig. 158, the pattern is developed the same as in Fig. 156. In the problems that follow, the patterns are developed with and without the aid of the plan. Being familiar with both methods, the student, in practice, can apply either as best suits the work he has in hand.

FIG. 159. Shows the plan and elevation of a transition piece from square to rectangle, both halves of which are not symmetrical when cut diagonally through 4-2, thereby making a plan view necessary in the development of the pattern. 1-2-3-4 is the plan of the base, and 5-6-7-8 the plan of the top, *a-b* showing the vertical height of the article.

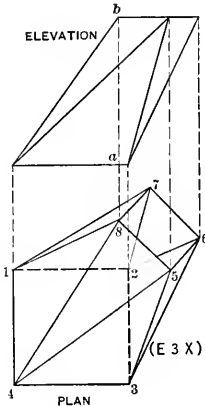

FIG. 159.

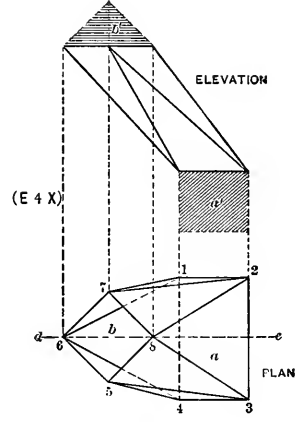

FIG. 160.

FIG. 160. Shows the plan and elevation of a transition from rectangular to square, both halves of which are symmetrical when cut through *de*. 1 to 4 is the plan of the base, and 5 to 8 the plan of the top. In this case no plan view is necessary in laying out

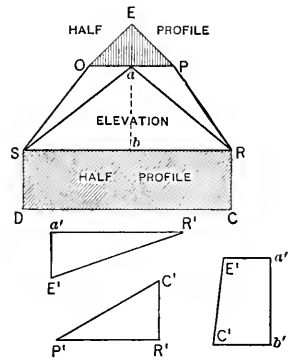

FIG. 158.

the pattern. Simply take the half profiles of *a* and *b* in plan, and place them in their proper positions in elevation as shown by the shaded parts *a'* and *b'*, and develop the half pattern as explained in connection with Fig. 158.

PATTERN FOR OBLIQUE CONE

FIG. 161. Shows the manner of developing the pattern for an oblique or scalene cone. The student should understand that any plane in a scalene cone drawn parallel to its base as *DE* in elevation, will have a similar shape as the base differing only in size. This applies to all articles, the bases of which can be inscribed in a circle. Let *ABC* represent the elevation of a scalene cone. Draw the plan view on the line *AB*, struck from the center *a* and through *a* draw the horizontal line *a-C'*, which intersect at *C'* by a line drawn from *C* in elevation at right angle to *AB*. Divide the circle *a*

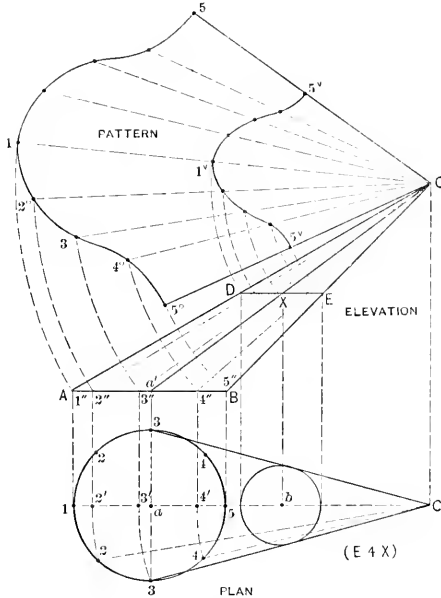

Fig. 161.

into equal parts shown from 1 to 5 to 1, and draw lines to the apex *C'*. (In enlarging this problem divide the circle *a* into twelve parts. With *C'* as center and radii equal to *C'1*, 3 and 2 draw arcs intersecting the center line *1C'* at *2'*, *3'* and *4'*, from

which points erect lines intersecting the base line AB at $2''$, $3''$ and $4''$. Lines are drawn to the apex C , but are not necessary in practice. Using C as center, with radii equal to $C1''$, $C2''$, $C3''$, $C4''$ and $C5''$, draw arcs as shown. Draw any line from the arc made from radius $5''$, as $5^{\circ}C$. Now set the dividers equal to the spaces contained in the plan a , and starting from 5° step from one arc to another, as shown by 4° , 3° , 2° and 1° , after which complete the opposite half to 5° . A line traced through these points as shown by $C5^{\circ}1^{\circ}5^{\circ}C$ will be the desired pattern. As previously stated, the section of any line or plane drawn parallel to the base will have similar section differing only in size; therefore to prove this, draw at pleasure any line as DE , and from a in plan erect a vertical line, intersecting AB at a' , from which draw a line to the apex C , cutting the line DE at X . From X drop a vertical line, intersecting similar center line in plan at b . Now, with b as center and radius equal to either XE or XD , draw the circle shown, which will be tangent to the lines $3-C$. $DEBA$ represents a frustum of an oblique cone, and to obtain the upper cut DE on the pattern, use C as center, and with radii equal to the various divisions on DE , draw arcs intersecting similar radial lines in the pattern, thus obtaining the cut $5^{\circ}1^{\circ}5^{\circ}$.

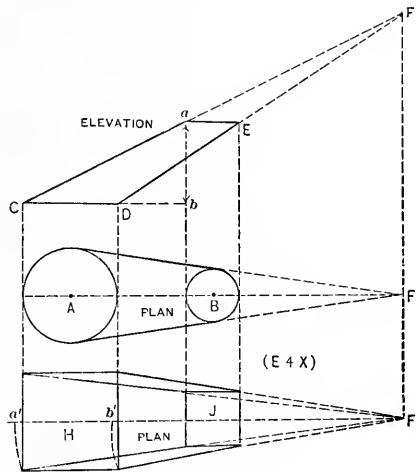

FIG. 162.

FIGS. 162 and 163. The preceding rule can be used whether the pipes are round or square, also when the ends are semi-circles, as shown in Fig. 163. In large work, when the center point C in Fig. 161 cannot be used in describing the patterns, a different method is employed, which will be explained later. The method in Fig. 161

is also employed for developing reducing offsets, as will be seen in the problem that follows. Obtain the pattern for a reducing offset, having outlet equal to A in Fig. 162 and an inlet equal to B ; the distance from center to center being equal to AB and the vertical height equal to ab . Construct from the plan the elevation $aEDC$, and extend the lines until the apex is obtained. Obtain the apex F^1 in plan and proceed to develop the pattern as explained in Fig. 161. Referring again to Fig. 162, make a new drawing and in a like manner obtain the pattern for a reducing square pipe. The sizes of H

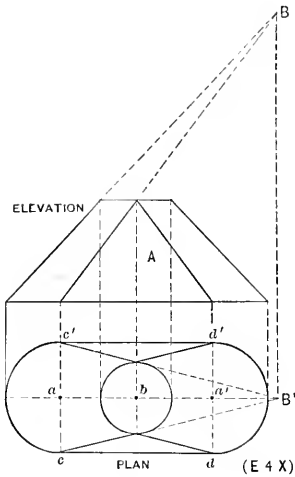

FIG. 163.

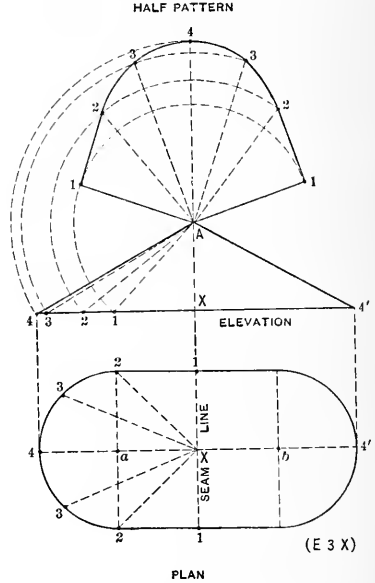

FIG. 164.

and γ are as shown. The altitude is to be equal to $a-b$. The true lengths of the corners must be obtained as partly indicated by a' and b' . In Fig. 163 the pattern is to be obtained for the transition piece, the sides of the base being flat, with semi-circular ends, and the top round. In this problem $a-b$ and $a'b'$ in plan, represent each one-half of a scalene cone, whose apex in elevation and plan are shown respectively by B and B^1 . When the pattern for $a-b$ is developed, it is only necessary to add the flat sides $c-d$ and $c'd'$ to it. This flat part appears in elevation by A , but does not show its true surface.

PATTERN FOR RAISED COVER

FIG. 164. The principle given in the preceding problem is applicable to the raised cover development in Fig. 164, where 1-4-1-4' is the plan view and 4-A-4' the elevation, the semi-circles in plan being struck from a and b . As the four quarters in plan are symmetrical, then divide the quarter plan as shown from 1 to 4, being careful to have more divisions when enlarging the problem. Draw lines to the apex X in plan and let 1-X-1 represent the seam line of the cover. Take the various distances in plan as $X1$, $X2$ and $X3$, and place them in elevation from X to 1, 2 and 3 and draw lines to A . These lines then represent the true lengths of similar numbered lines in plan. For the half pattern use A as center and with radii equal to $A1$, $A2$, $A3$ and $A4$ draw arcs as shown. From the arc made from point 4 draw the line 4-A in the pattern. Next set the dividers equal to the various divisions in the quarter plan 4-1 and lay the spaces off on corresponding arcs in the pattern, on either side of the line 4-A. A line traced through the various intersections shown by $A-1-4-1-A$ is the half pattern, with seam on 1-1 in plan.

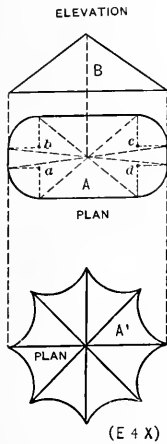

FIG. 165.

FIG. 165. By the preceding method solve the two problems given in Fig. 165, the altitude in elevation of both to be equal to B . A is the plan view of the one with rounded corners, struck from the centers $a-b-c$ and d , and plan $A1$ is a rosette having eight flutes. Separate drawings are to be made for each problem.

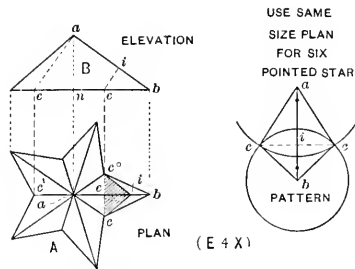

FIG. 166.

FIG. 166. The principles in Fig. 165 also apply to Fig. 166, which shows a plan view of a five-pointed star, the height of which is equal to $n-a$ in elevation. As $a-b$

in plan is placed on a horizontal line, $a-b$ in elevation will show its true length on $a-b$ in plan. In plan $c-b$ also shows its true length. The true length of $a-c$ in plan is obtained by taking the length of $a-c$ or $a-c'$ in plan, and placing this distance from u to c in elevation, and drawing a line from c to a the length desired. For the pattern, make $a-b$ in the pattern equal to $a-b$ in the elevation; with bc in plan as radius and b in pattern as center, draw the circle $c-c$, which is intersected by the arc $c-c$, struck from a as center and $a-c$ in elevation as radius, then $a-c-b-c-a$ is the pattern for one point. If a section were required on the line $c-c^\circ$ in plan, at right angle to $a-b$ in elevation, then extend $c-c^\circ$ until it intersects the base line in elevation at e , from which point at right angle to $a-b$ draw ei . Place this distance ei from e to i in plan. The shaded section is the true profile desired, and the distance of either ic or ie° will equal ic in the pattern. In similar manner develop the pattern for a six-pointed star, making a separate drawing.

PATTERN FOR TRANSITION PIECE, IN WHICH BOTH HALVES ARE SYMMETRICAL AND NO PLAN IS REQUIRED

FIG. 167. In developing this problem the principles made use of are those given in connection with Figs. 158 and 160, and as illustrated in Fig. 167, which shows a transition piece, both sides being symmetrical as indicated in plan. When the student becomes familiar with this method of development, no plan view is necessary, but is here shown so as to make clear the various steps taken. In this method, when omitting the plan, the elevation of the article to be developed *must always be drawn at a right angle to the line which divides the article into two symmetrical parts*, as per line $a-b$ in plan. Let 1-5-6-9 be the elevation of the transition piece. Place the half profile of the round top on 1-5, as shown by 1-3-5, and the half profile of the rectangular base on 6-9, as shown by 6-7-8-9. Divide the semi-circle into equal spaces as shown (being careful to use double the number of divisions in enlarging this problem) and from the points 2 to 4 drop vertical lines intersecting 1-5 at 2'-3' and 4'. From points 2' and 3' draw lines to 9 and from 3' and 4' draw lines to 6. These lines will then represent the base lines of the sections to be constructed, the altitudes of which will be equal to the various heights in the half profiles. These true lengths are shown in A and B and are drawn as follows: Take the distances in elevation of 9-1, 9-2' and 9-3' and place them on the horizontal line in A , as shown by similar numbers. At right angle to the horizontal line in A , erect the lines 9-8, 2'-2 and 3'-3, equal respectively to similar numbers in the half profiles in elevation. Then 8-1, 8-2 and 8-3 in A represent the true lengths of similar lines in elevation. The true lengths shown in B are obtained in a similar manner from measurements in elevation. In this case two diagrams A and B are shown,

but in practice one diagram is sufficient on which all the true lengths can be found. Assuming that the pattern is to be developed in two pieces, with seams at *d* and *e* in plan, draw any line 1-9 in *D* equal to 1-9 in elevation. With 9-8 in the half profile as radius, and 9 in *D* as center, draw the arc 8, which is intersected by an arc, struck from 1 as center and 1-8 in *A* as radius. Draw a line from 1 to 8 to 9 in *D*. Now with 8 as center and radius equal to 8-2, and 8-3 in *A*, draw the arcs 2 and 3 in *D*. Set the dividers equal to 1-2 and 2-3 in the half profile, and starting from 1 in *D*, lay off this distance on arcs 2 and 3, and draw a line from 3 to 8. With 8-7 in the half profile as radius, and 8 in *D* as center, draw the arc 7, which intersect by an arc struck from

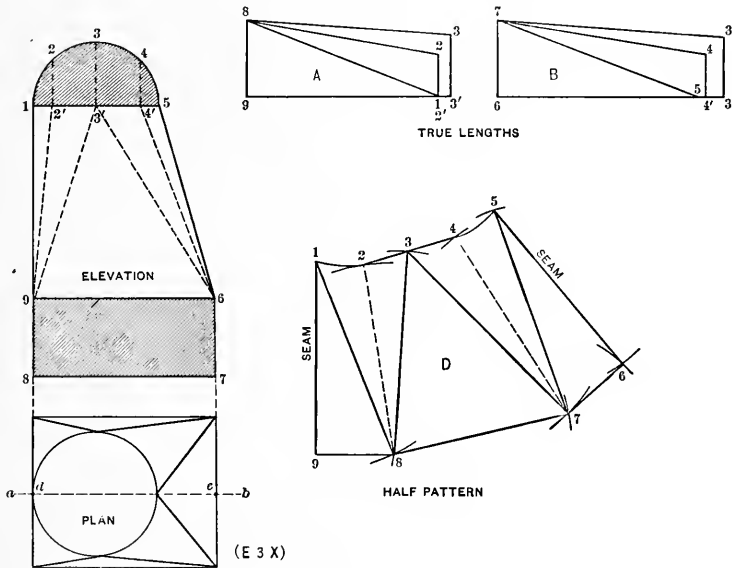

FIG. 167.

3 as center, and 3-7 in *B* as radius. Draw a line from 3 to 7 to 8 in *D*. Now with radius equal to 7-4 and 7-5 in *B* and 7 in *D* as center, describe the arcs 4 and 5. Set the dividers equal to the spaces 3-4 and 4-5 in the half profile in elevation, and starting from 3 in the pattern *D*, step to arc 4, then to 5 and draw a line from 5 to 7. With radius equal to 6-7 in the half profile in elevation, and 7 in *D* as center, draw the arc 6, which intersect by an arc struck from 5 as center, with radius equal to 5-6 in elevation. Draw a line from 5 to 6 to 7 in *D*. Then 5-6-9-1 is the half pattern. No matter what the profiles of the ends may be, the above principle is used, it being

immaterial whether the lines 1-5 and 6-9 run parallel to each other or not, as will be explained in the following problems. In the sixteen problems that follow, the profiles should be divided into twice the number of spaces shown in some of the problems, for the reason that the more spaces that are used, the more accurate is the pattern. The plan views will be shown in the sixteen problems that follow, but that view is not necessary in the development of the patterns; they indicate only that both halves of the article are symmetrical. In developing these patterns for these sixteen transition pieces, only one-half the pattern is required, with seams through *a-b*, excepting Figs. 182 and 183, in which the full patterns are required. In Fig. 167 a transition was developed, in which one side was vertical.

FIG. 168. In this figure a transition piece is to be developed where the upper pipe comes directly in the center of the rectangular base. *A* shows the elevation, *B* the half profile of the top and *C* the half profile of the base.

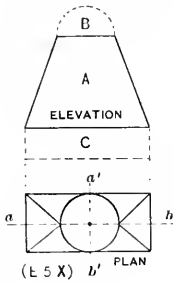

FIG. 168.

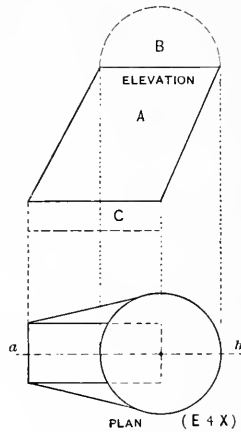

FIG. 169.

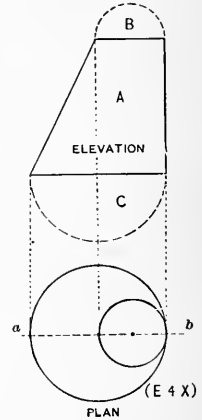

FIG. 170.

FIG. 169. Develop the half pattern of the transition piece, whose base is rectangular and top round, placed to one side. It will be noticed that the elevation *A* is drawn at a right angle to the line *a-b*, which divides the article into two symmetrical parts. On the top of the elevation *A* in Fig. 169 the half section *B* is placed, and on the bottom, the half section or profile *C*, the true lengths and pattern being obtained as in Fig. 167.

FIGS. 170 and 171. In Fig. 161 we explained how the pattern for an oblique cone was developed when the center point could be used. Figs. 170 and 171 show how a transition piece forming a frustum of an oblique cone is developed, when the work is

large and no center can be used. The principles are exactly the same as in Fig. 167. In Fig. 170 is shown a transition piece, both ends of which are round, one side being vertical. *A* shows the elevation with both half profiles in position as *B* and *C*. The method of drawing the base lines is the same as given in Fig. 171, in which the top opening is placed outside of the lower one. The elevation *A* and the half sections or profiles being drawn, *B* and *C* are both divided into the same number of spaces, and from these points lines are drawn at right angles to their respective base lines as shown. Alternate solid and dotted lines are then drawn as shown, connecting opposite points, after which the true lengths and pattern are obtained as before.

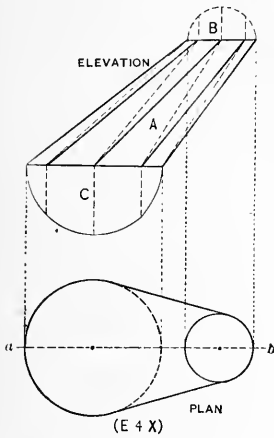

FIG. 171.

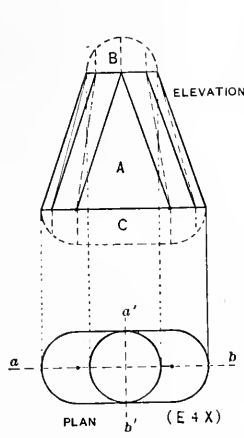

FIG. 172.

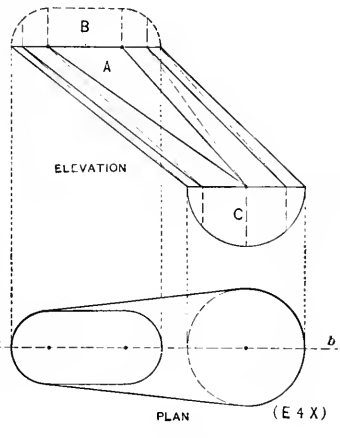

FIG. 173.

FIG. 172. Shows a transition piece, having a top that is round and base that is oblong with semi-circular ends. The half profiles *B* and *C* are placed on the elevation as shown, and each of the quarter circles in *C*, divided into one-half the number of spaces contained in *B*. Then solid and dotted lines are connected as shown.

FIG. 173. Is a problem where the oblong top is similar and connected to a round base placed outside the top. The half profiles *B* and *C* are placed on *A* as shown, and divided as shown and explained in the previous problem.

FIG. 174. Shows a transition piece, the bottom of which is oblong, placed at right angles to the center line *a-b*, the top being a rectangle. Note that the semi-circle in *C* is equally divided, and lines carried to the base line $6'-10'$, thence to the corners $2'$ and $3'$. $2'-10'$ and $6'-3'$ in *A* show their true lengths, but the others must be found as previously explained.

FIG. 175. Shows a transition piece where two oblong pipes, with semi-circular ends, cross each other. The elevation *A* is drawn and the half profiles placed in the position shown. Be sure to divide the quarter circles in *B* and *C* into the same number of parts as shown, and connect solid and dotted lines as there indicated. Whether the profiles are oblong or elliptical the rules remain the same.

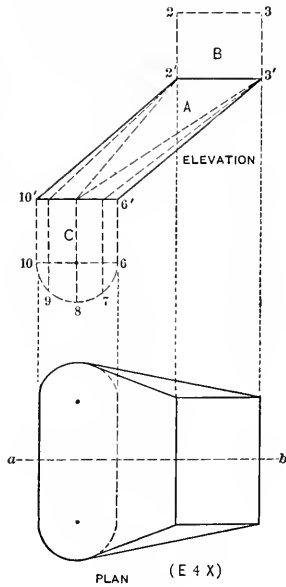

FIG. 174.

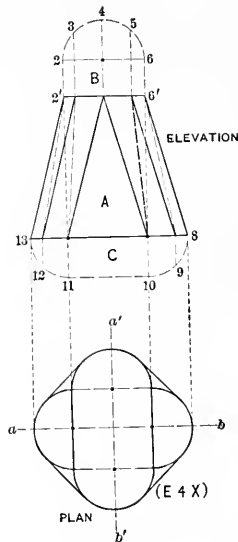

FIG. 175.

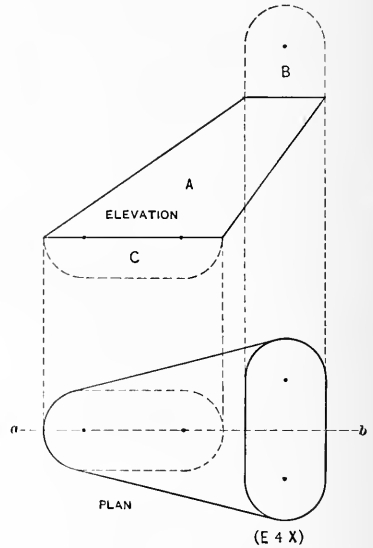

FIG. 176.

FIG. 176. Shows a similar problem, the upper opening being placed away from the lower. The half profiles *B* and *C* are joined to *A* as shown, and spaced in a manner similar to Fig. 175.

FIG. 177. Shows a transition piece where the top plane $a'c'$ does not run parallel with the bottom. In this case, as in the others, no plan view is required; for knowing that both halves on either side of $a-b$ are symmetrical, the half profiles are placed on either end of *A* as shown by *B* and *C*, both of which are divided into the same number of spaces and the solid and dotted lines drawn as before. A horizontal view on $a'-c'$ would show an elliptical figure in plan. Although this view is not necessary, the method of obtaining it will be described. $a'b'c'$ in plan is equal to $a'b'c'$ in elevation, and $a''c''$ in plan is obtained by projecting vertical lines from $a'-c'$ in elevation as shown.

FIG. 178. In this figure *A* shows the side view of a transition piece, whose openings run at right angles to each other. A front and plan view are shown to make the drawing more clear, but are not necessary when developing the half pattern. The method of spacing the half profiles *B* and *C* are clearly shown.

FIG. 179. In this figure the inlet and outlet are both rectangles, otherwise the problem is similar to Fig. 178. In this problem no front or plan views are required, the half profiles *B* and *C* being placed on *A* as shown. As the half profiles have no curved surfaces, the only line required is that from *3'* to *7'*. The true lengths and half pattern are obtained in precisely the same manner as in former problems. If, in this problem, one end was square and the other round, the method of drawing the solid and dotted lines would be the same as in Fig. 167.

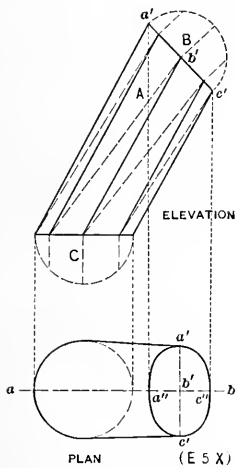

FIG. 177.

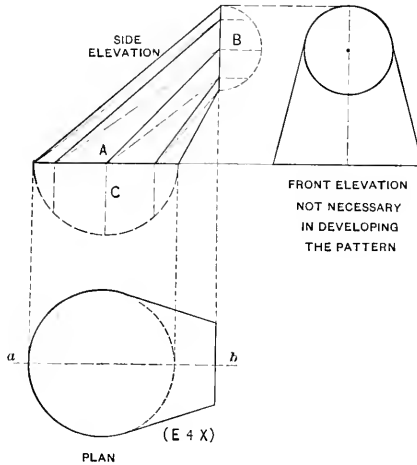

FIG. 178.

FIG. 180. In this figure 1-5-6-10 is the elevation of a tapering collar, to fit over a pitched roof, indicated by *DE*. The lower part of the collar along the line *DE* is to have an equal horizontal projection all around the upper opening 1-5, as indicated by *hi* and *de*. The full horizontal diameter is equal to *rs*, which bisect and obtain *t*. From *t* drop a vertical line, cutting *DE* at *n*, and from *n* draw the perpendicular *n-8* equal to *rt* or *ts*. Now, through *h-8-e* draw the curve shown, which in this case has been struck from *w*. The half profiles *B* and *C* are spaced as shown.

FIG. 181. Shows a similar collar having a round top and a square base, when viewed on a horizontal line. In other words the projection on either side of the round top is to be equal, as shown by $d-8'$ and $e-7'$. The full distance being equal to hi , take one-half of this and place it at a right angle to $8'-7'$, as shown by $8'-8$ and $7'-7$. The half profiles B and C are then placed on A as shown.

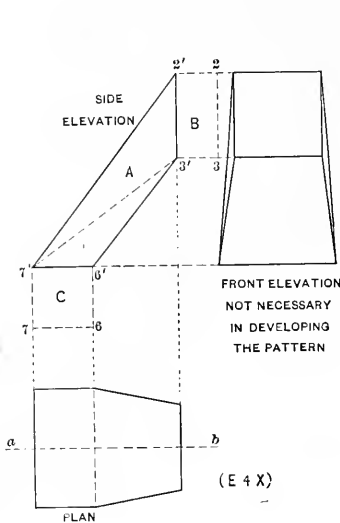

FIG. 179.

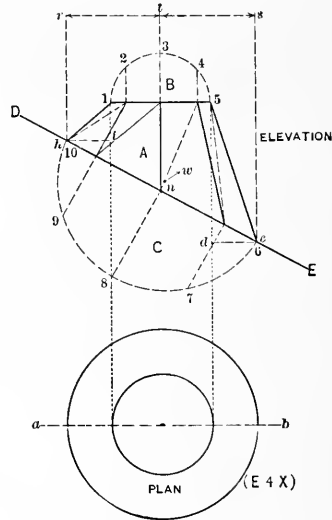

FIG. 180.

FIG. 182. In this figure A shows the side view of a tank hood, the section of which on the base line is equal to part of a circle, as shown in plan by cfe , and the section on the vertical line in A being shown in front view by $c'ie'$. It should be understood that no plan or front view is necessary when developing the pattern. All that is required is the half profile def placed at C , and the half profile $c'd'i$ placed at B . Both profiles are divided into the same number of parts as shown, and the true lengths obtained and full pattern developed. If the height $d'i$ in front view were not given, the pattern could be obtained by parallel lines as shown in Figs. 39 and 40 in Part One.

FIG. 183. Illustrates the development of the full pattern for a forge hood. $1-5-6-8^{\circ}-10$ is the side view of the hood, B the half profile of the upper opening, C the half profile of the forge, to which it connects as shown in plan by hij , and D the section which must be found by drawing a line at a right angle to $10-8^{\circ}$, from the point 8° to $8'$, equal in length to $8^{\circ}-8$, and then at pleasure drawing the curve $8'-10$. In spacing

the profiles in any article in which three profiles are given, the following rule should always be followed, *viz.*: To divide the profile *B* into as many divisions as there are spaces in the profiles *C* and *D*. In enlarging this problem more divisions should be used than here shown. There is no limit to the various transition pieces which can be developed by the method of omitting the plan, when both halves are symmetrical.

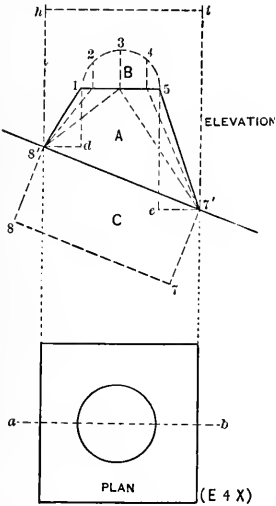

FIG. 181.

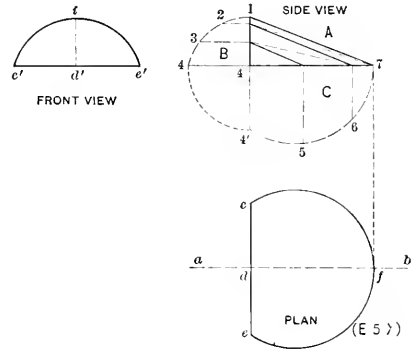

FIG. 182.

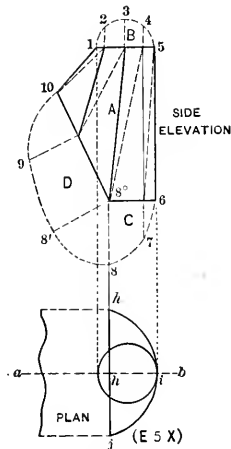

FIG. 183.

PATTERN FOR A TRANSITION PIECE, IN WHICH BOTH HALVES ARE NOT SYMMETRICAL, AND A PLAN IS REQUIRED

FIG. 184. Shows a transition piece. The base is rectangular and top round, and the halves are not symmetrical. In this case the true lengths are obtained by using the lines in plan as the base lines, and the vertical height bc as the altitude. $ABCD$ is the plan of the base, and 1-3-5-7 the plan of the top, struck from the center a . $EFH\tilde{}$ is the elevation. In diagram L the true lengths appear for those lines shown in plan in $A-1-3$. In diagram M , N and O the true lengths are shown respectively for

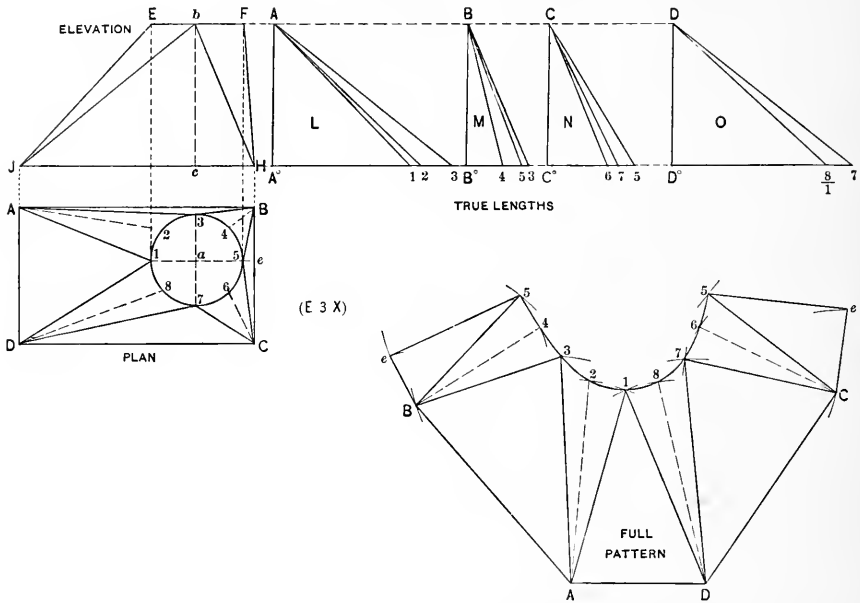

FIG. 184.

the lines in plan in $B-3-5$, $C-5-7$ and $D-7-1$. For example: the distances of A_1 , A_2 and A_3 in plan are placed on the line \tilde{H} extended, as shown by A^o_1 , A^o_2 and A^o_3 , and slanting lines drawn to A also shown, A^oA being the altitude equal to $a-b$. Assuming that the pattern is desired in one piece with a seam along $5e$ in plan, start by taking AD in plan and placing it on AD in pattern. Using A and D as centers, with radii equal to $A-1$ in L and D_1 in O , draw arcs intersecting each other at 1 in the pattern. Proceed to develop the pattern as shown in Fig. 167, following the reference figures

and letters in Fig. 184, the lengths $5e$ in the pattern being obtained from FH in the elevation. By comparing measurements between the plan, the true lengths and the pattern, no trouble should be experienced in developing the pattern by following reference letters and figures.

FIG. 185. Develop the full pattern for the transition piece shown in Fig. 185, with the seam on $A1$ in plan, the vertical height being indicated by $a-b$ in elevation. The method of obtaining the true lengths and pattern is similar to that shown in Fig. 184, but care must be taken to divide the plan view as indicated in Fig. 185. Note how the sides of the rectangular base terminate in the four parts of the circle; that is, AD to 1, DC to 7, CB to 5, and BA to 3; then each of the quarter circles to corresponding corners in the base. In plan, c is the center of the circle.

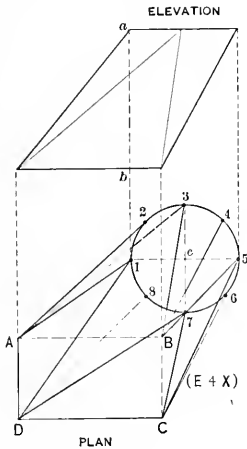

FIG. 185.

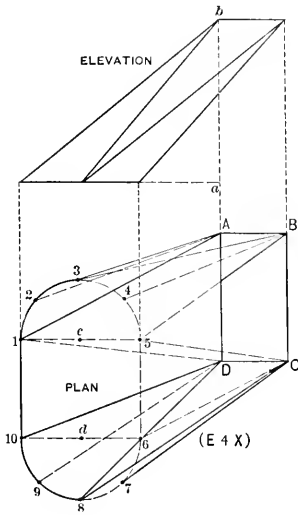

FIG. 186.

FIG. 186. Is the plan and elevation of a transition piece oval to rectangle. The vertical height is equal to $a-b$ and the semi-circles in plan are struck from c and d . The flat surface 1-10 connects to $A-D$, 5-6 to $B-C$, CD to 8, and BA to 3. The quarter circles 1-3 connect to A , 3-5 to B , 6-8 to C , and 8-10 to D . Develop the full pattern with a seam on 1-A.

FIG. 187. Develop the full pattern for the transition piece shown in Fig. 187, with a seam on $1-1'$. The flat sides in the oval section $1'-1''$ run to 1, and $5'-5''$ run to 5. The semi-circles in top and bottom are both divided into similar spaces as shown and

connected by solid and dotted lines. Thus, solid lines are drawn from 6 to 6', 7 to 7', 8 to 8', etc., and then the dotted lines connected the shortest way, as from 6 to 5'', 7 to 6', etc. *a* and *b* are the centers of the semi-circles, *c* the center of the circle, and *cd* the vertical height of the transition. In obtaining the true lengths, make a separate diagram for the solid lines, and a separate one for the dotted lines.

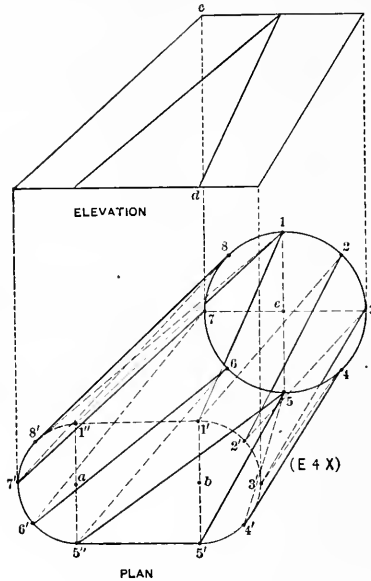

FIG. 187.

PATTERN FOR TRANSITION ELBOW, ROUND TO OBLONG, IN WHICH THE EXTERIOR ANGLE IS A RIGHT ANGLE

FIG. 188. Shows the method employed, when transition elbows are to be developed in two pieces, whether the exterior angle is a right angle or otherwise, and the upper arm a parallel pipe, and the taper taking place on the inside angle of the lower arm. In this case there is a transition elbow having an oblong inlet with semi-circular ends and the outlet a circle. *A* represents the elevation of the elbow, *B* the profile of the top arm and *C* the profile of the opening of the lower arm. The miter line 1-5 can be the bisection of the exterior angle, or may be established at pleasure. The profile *B* is divided into equal spaces (have more spaces in enlarging the problem) and lines

carried parallel to the upper arm, until they intersect the miter line 1-5. The pattern for the upper arm is shown by *D* and is obtained as explained in Part One on Elbow Patterns. The pattern for the lower arm forms a transition piece and is developed by triangulation as follows: Divide the semi-circles in the profile *C* into the same number of spaces as shown in the semi-circles in *B*. Erect vertical lines from *C*, intersecting the base of *A* as shown. Draw solid and dotted lines in *A* as shown and obtain the

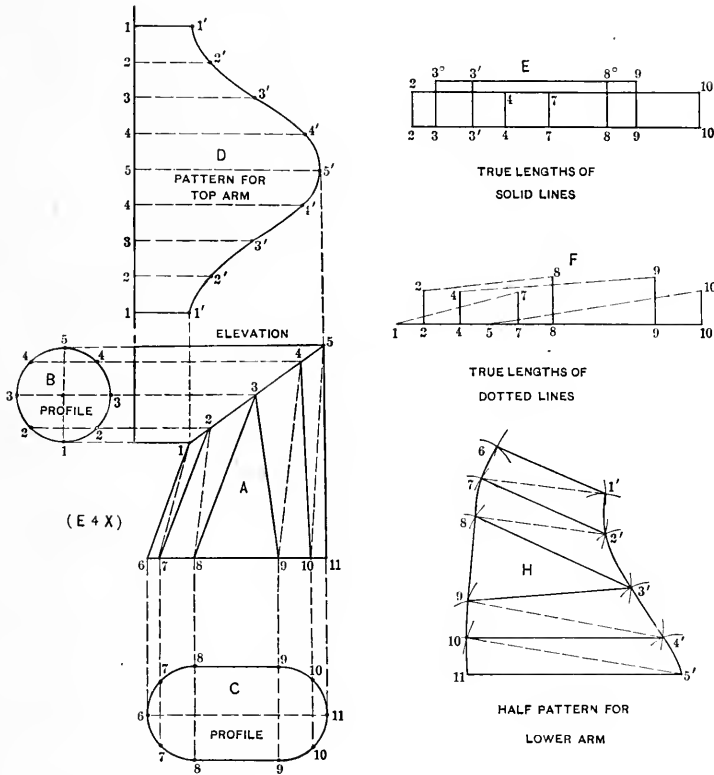

FIG. 188.

true lengths of the solid lines in *A*, by taking those distances and placing them on the horizontal line in *E*, as shown by similar numbers, and from these numbers erect vertical lines, making them equal in height to similar numbers in *B* and *C*, measuring from the line 1-5 and 6-11 respectively. For example: 3-8 in *A* is placed on the horizontal line as 3-8 in *E*, the vertical heights 3-3° and 8-8° being equal to the heights

measured from the line 1-5 to the point 3 in *B*, and from the line 6-11 to the point 8 in *C* respectively. $3^{\circ}8'$ in *E* then shows the true length of the line 3-8 in *A*. In this manner all of the true lengths of the solid lines in *E* and dotted lines in *F* are obtained. The pattern for one-half the lower arm is shown developed and is obtained as follows: Take the distance 5-11 in *A*, which shows its true length, and place it as shown by 11-5' in *H*. Using 11-10 in *C* as radius, and 11 in *H* as center, describe the arc 10, which intersect by an arc struck from 5' as center, and 5-10 in *F* as radius. Now, with 5'-4' in the pattern *D* as radius, and 5' in *H* as center, describe the arc 4', which intersect by an arc struck from 10 as center and 10-4 in *E* as radius. Proceed in this manner, using alternately as radius, first the divisions in the profile *C*, then the true length in *F*; the divisions in the miter cut in *D*, then the true lengths in *E*, the distance 1'-6 in *H* being obtained from 1-6 in *A*.

FIG. 189. Apply the same principles given in Fig. 188 to Fig. 189, in which an elbow is shown round to square. *A* is the elevation of the upper arm, and *D* its profile. *B* is the elevation of the lower arm, and *C* its profile on 1'-5'. The pattern for *A* is laid off on *ed*. Solid and dotted lines are drawn in *B* as shown. The true lengths of the lines are obtained by using these lines as bases, and the heights in the semi-profiles *D* and *C* as altitudes, measuring from the lines *a-b* in *D*, and 1-5 in *C* respectively.

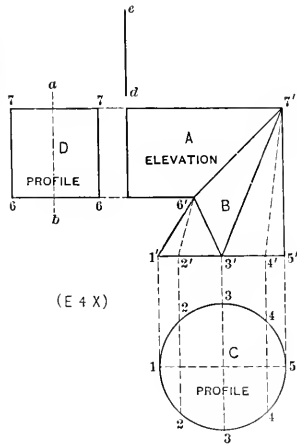

FIG. 189.

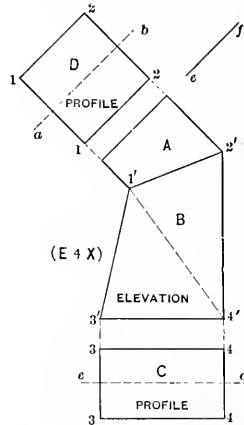

FIG. 190.

FIG. 190. Develop the patterns for an elbow rectangle to square, having an exterior angle of 45° . The pattern for *A* is laid off on *cf*. *D* is the profile for the opening in *A*, and *C* for the opening in *B*. A dotted line is drawn from 1' to 4'. The altitudes

for obtaining the true lengths are obtained from the semi-profiles *D* and *C*, with bases equal to the lines in *B*. Note the reference numbers in the profiles.

FIG. 191. Shows an elbow to be developed, both profiles of which, *D* and *C*, are equal but cross each other at right angles when viewed in plan. Note how the profiles are spaced and the dotted and solid lines drawn. The pattern for *A* is laid off on *cd*, the true lengths obtained by using the lines in *B* as base lines, and the heights in the semi-profiles *D* and *C* as altitudes. The pattern for *B* is obtained in a similar manner to that used for obtaining *H* in Fig. 188.

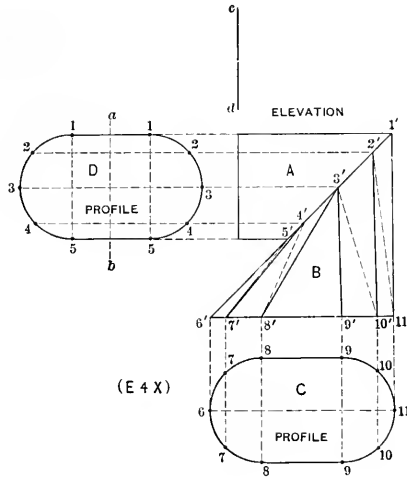

FIG. 191.

PATTERN FOR TRANSITION ELBOW, ROUND TO OBLONG, IN WHICH BOTH EXTERIOR AND INTERIOR ANGLES TAPER

FIG. 192. The principles given in connection with Fig. 192 can be applied to any tapering elbow, no matter what profile either end may have. Let *ABCDEF* be the elevation of a tapering elbow with section on *DC* as shown by *G*, and section on *AF* as shown by *H*. Since the width of one-half of *H* is less than one-half of *G*, the width at *i'* on *EB* should be a medium between the two. Therefore, take the distance of *i-c* in *H* and place it from *i* to *e'* in *G*. Bisect *e'-f* and obtain *o*. Then *i-o* is the distance to be placed in the center and at a right angle to *EB*, as shown by *i'-o'*. Through

Eo'B draw the semi-elliptical figure shown which will be the true half section on *EB*. Knowing the true profiles or sections on *AF*, *EB* and *DC*, proceed to obtain the pattern in precisely the same manner as explained in connection with the transition piece in Fig. 167 and as solved in the problems Fig. 168 to Fig. 181 inclusive. *X* in Fig.

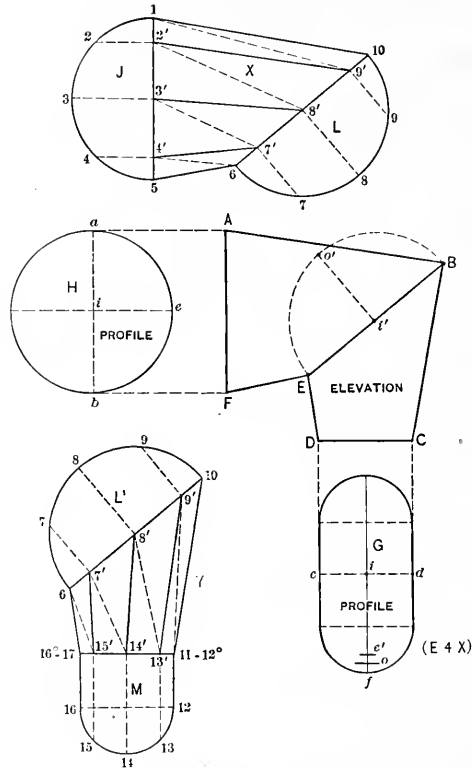

FIG. 192.

192 is a reproduction of *ABEF*, $\frac{1}{2}$ the half profile of *H*, and *L* a reproduction of *Bo'E* in elevation. The sections $\frac{1}{2}$ and *L* are divided as shown. *Y* is a reproduction of *BEDC*, *L'* being a reproduction of *L* in *X*, and *M* one-half of the section *G*. The semi-circle in *M* is divided into as many spaces as contained in *L'*, and solid and dotted lines drawn in the usual manner.

FIG. 193. Develop the patterns for a tapering two-pieced elbow from round to rectangular, as shown in Fig. 193. The opening of *A* is shown by *C*, while the opening

of *B* is shown by *D*. The distance *ac* in *C* is set off from *a'* to *c'* in *D*, and the distance *h* to *c'* bisected, thus obtaining *i*. This distance *a'-i* is set off at a right angle to *a°-a°*, as shown from *a°* to *i°* on both sides. Reproductions of *A* and *B* with their respective profiles are then drawn as explained in Fig. 192.

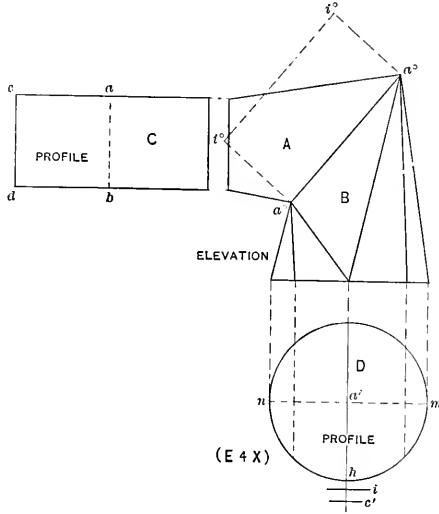

FIG. 193.

PATTERN FOR THREE-PIECED TRANSITION PIECE

FIG. 194. The problem given in Fig. 194 does not differ from that given in Fig. 188 as far as the principles are concerned. Fig. 194 shows the elevation of a three-pieced transition piece round to round. *A* is the upper arm with profile as shown by *B*, and *C* the lower arm, the profile of which is *D*, both being parallel pipes. Both profiles are divided into similar number of spaces as shown, and lines carried parallel to the line of the pipes *A* and *C*, until they intersect the miter lines 6-10 and 1-5 respectively. The patterns for *A* and *C* are obtained by parallel lines as shown. Solid and dotted lines are now drawn in *H* and represent the base lines of sections which are to be constructed, with altitudes equal to the various distances in the semi-profiles *B* and *D*, each having similar numbers; or in exactly the same manner as explained in connection with diagrams *E* and *F* in Fig. 188. After the true lengths have been obtained for Fig. 194, the pattern for *H* is developed, by using the true lengths

which are to be found, and the various distances in the miter cuts *F* and *E*, or in exactly the same manner as explained in connection with developing the pattern *H* in Fig. 188. The diagram of sections and pattern for *H* in Fig. 194 are not shown, but are to be drawn when enlarging this problem.

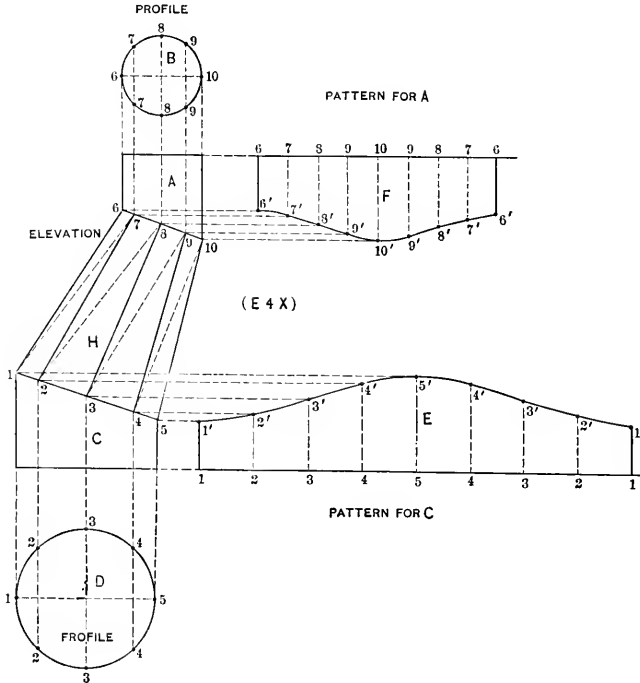

FIG. 194.

FIG. 195. Develop the patterns for a transition boot, oblong to square, illustrated in Fig. 195. *A* is the upper arm, having profile *B*, and *C* the lower arm, having profile *D*. The patterns for both of these arms are laid off on *c-d* and *a-b* respectively. The profiles are spaced and numbered as shown, and the true lengths of *E* and its pattern are obtained as in Fig. 194. A line should be drawn from 1 to 5 in elevation in Fig. 195.

FIG. 196. Develop the patterns for a three-pieced elbow round to square. The pattern for the square pipe is laid off on *c-d* and for the round pipe on *a-b*. The method of spacing the profile is shown.

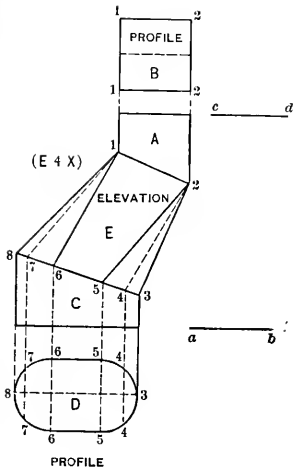

FIG. 195.

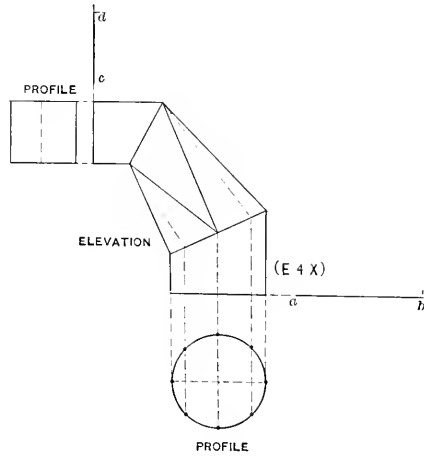

FIG. 196.

FIG. 197. In this figure develop patterns for an elbow oblong to round. It makes no difference whether the transition piece is shaped as shown in Fig. 194 or as shown in Fig. 197, the same methods apply in each case.

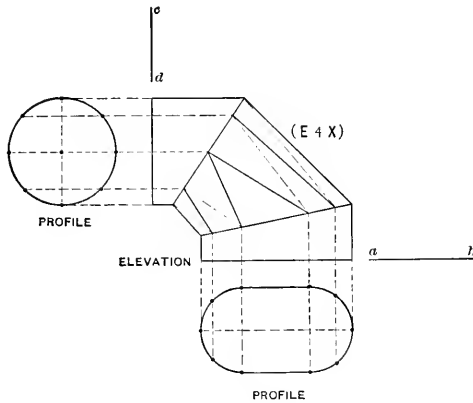

FIG. 197.

PATTERN FOR TWO-PIECED TAPERING FORK

FIG. 198. Shows the principle that can be used in developing a two-pieced tapering fork, in which the diameters of both *A* and *B* are equal. Draw the elevation as shown, and at right angle to the various openings place the profiles in position. As *hk* represents the seam line between the two forks, a true section must be found on this line as follows: As the horizontal distance through *k* is equal to *b-c* in the profile, then take one-half this distance as *a-c*, and place it at right angle to *h-k*, as shown by *k-i*, and at pleasure draw any desired curve as *i-h*. The shaded part *h-k-i* then becomes the true half section on *h-k* and is used when obtaining the pattern by triangulation, in a manner as shown in Fig. 183, and as will be explained in connection with Fig. 198.

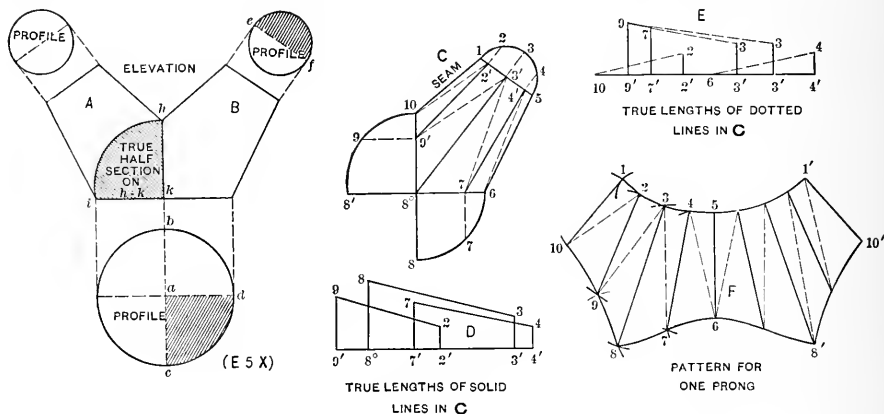

FIG. 198.

To avoid a confusion of lines, *C* is a reproduction of *B*. Take the half shaded profiles *c-f*, *h-k-i* and *a-c-d* in *B* and place them in *C*, as shown respectively by *1-3-5*, *10-8°-8'* and *8°-8-6*. Divide the profiles into equal spaces as shown, being careful to divide *1-3-5* into as many spaces as there are spaces in *10-8'* and *8-6*. From the points in the various profiles, perpendicular lines are drawn as shown, and solid and dotted lines drawn in the usual manner. Diagrams *D* and *E* show the true lengths of the solid and dotted lines respectively. See similar reference figures. For example: To obtain the true length of the dotted line *4'-6* in *C*, place the length of that line on the horizontal line in *E*, shown from *4'* to *6*; from *4'* erect the perpendicular *4'-4* equal to *4'-4* in the profile in *E*. As point *6* in *C* has no height, draw a line from *4* to *6* in *E*, which is the true length desired. Proceed in similar manner for the true lengths shown in

D and *E*. As both prongs *A* and *B* are similar, only the pattern shown by *F* is required. Assuming that the seam is to come on 1-10 in *C*, the pattern is developed as follows: Take the distance 5-6 and place it on 5-6 in *F*; with 5-4 in *C* as radius, and 5 in *F* as center, draw the arc 4, which intersect by an arc struck from 6 as center, with 6-4 in *E* as radius. Now, with 6-7 in *C* as radius, and 6 in *F* as center, draw the arc 7, which intersect by an arc struck from 4 as center, and 4-7 in *D* as radius. Proceed in this manner until the line 3-8 is obtained. Then using 8'-9 in *C* as radius and 8 in *F* as center, draw the arc 9, which intersect by its proper radius found in *E*; then use the spaces in 1-5 in *C*, and the proper length in *D*, until the line 1-10 in *F* is drawn, which is obtained from 1-10 in *C*. No matter what profiles the prong may have or in what positions the prongs are placed, the foregoing rule holds good. More spaces should be used in dividing the profiles, when enlarging this and the various problems which will follow.

FIG. 199. Shows a prong from round to oblong. Both prongs are equal and the pattern for either *A* or *B* only is needed. The true half section on *c-a'* is shown by

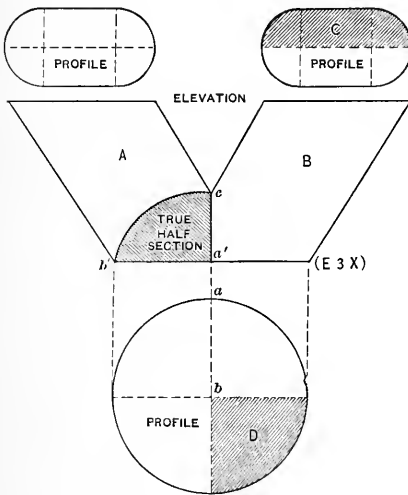

FIG. 199.

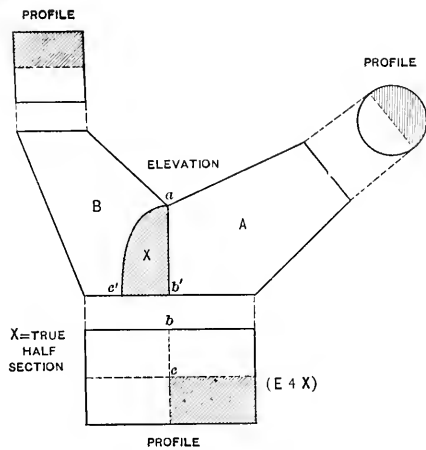

FIG. 200.

c-a'-b'; the distance *a'-b'* being obtained from *a-b*. The true half section, and the shaded profiles *C* and *D* are used when developing the pattern.

FIGS. 200 and 201. In similar manner develop the patterns for a two-pronged fork, the base being a rectangle and the opening of one prong being round and the other

square, each prong having a different angle as shown in Fig. 200. N shows the true half section on $a-b'$, the distance $b'-c'$ being obtained from bc . The shaded profiles show the parts to be used when developing the arms A and B , which are reproduced by A and B in Fig. 201 to show how the shaded profiles in Fig. 200 are placed in position in Fig. 201. Note how the profiles are spaced and the solid and dotted lines drawn. Develop the pattern for each arm.

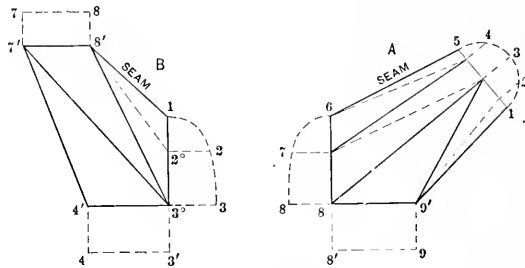

FIG. 201.

PATTERNS FOR TWO-PIECED TAPERING FORK, MITERING WITH PARALLEL PIPES AT ANY ANGLE

FIG. 202. Shows how the patterns are developed when the prongs are mitered to horizontal or vertical pipes. $ABCD$ is the elevation of the prong, the base being round, the prong C mitering with the horizontal pipe D , and prong B mitering with the vertical pipe A . The true section on $H\tilde{f}$ is obtained the same as in Fig. 198, but the true sections on the miter lines 1-5 and 6-10 are obtained as follows: Divide the profile F in equal parts as shown, from which parallel to the lines of the pipe D draw lines intersecting the line 1-5, at 1, 2, 3, 4 and 5. From these points at right angle to 1-5 erect lines equal in height to similar numbered lines in F , measuring from the line 1-5. Through the points 1-2'-3'-4' and 5, trace the semi-elliptical section shown shaded by N , which is the half true section on 1-5. In similar manner obtain L . Having the true half section on the line 1-5 shown by N , the true half section on $H\tilde{f}$ shown by R , the true half section on the line 6-10 shown by L , and the quarter section P , the true lengths of the solid and dotted lines (not here shown) and the patterns for B and C are to be obtained in precisely the same manner as described in connection with C in Fig. 198. Care must be taken in enlarging this problem that the half profiles L and N are each divided into as many spaces as are contained in the profiles R and P . The pattern for the pipe D is laid off on $a-b$, and the pattern for A , laid off on cd . The pat-

terns for *B* and *C* are to be developed, and when completed will form a fork as shown in elevation. Or, two prongs like *C* could be joined, making a fork shown by $C^{\circ}C^{\circ}$, or two of *B* joined, making a fork shown by $B^{\circ}B^{\circ}$.

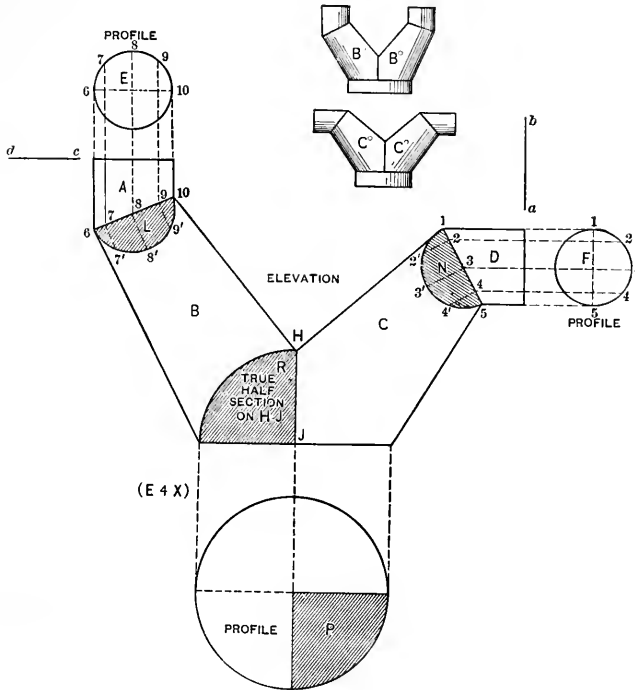

FIG. 202.

FIG. 203. Develop the patterns for a fork as shown in Fig. 203, the base being a rectangle, the opening of one prong round and the opening of the other square. The patterns for the parallel pipes are laid off on *a-b* and *c-d*. The true sections on the miter lines are obtained as in the preceding problem, and the true section on the seam line *ea'* obtained, by taking the distance *ab* and placing it as shown by *a'b'*. At pleasure obtain the desired section, which can be drawn as shown by *e-f-b'-a'*, or as shown by *cb'a'*, or a straight line can be drawn from *c* to *b'*. It is immaterial what shaped section is placed on *e-a'*, providing the distance of *a'b'* is equal to one-half of the width of the base as shown by *a-b*.

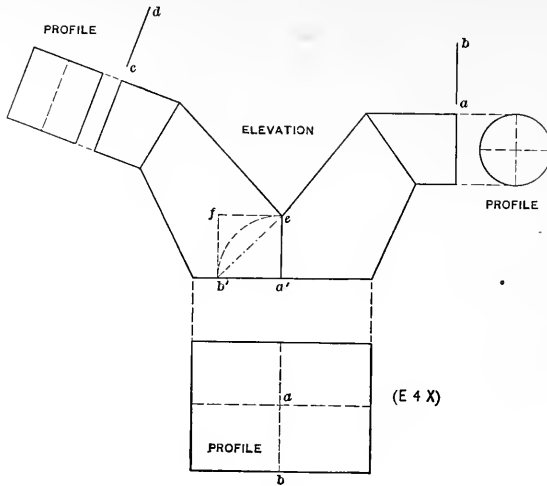

FIG. 203.

PATTERN FOR A THREE - PIECED TAPERING FORK

FIG. 204. Shows the principle required in developing forks which contain three or more prongs. This same principle is applicable whether the prongs pitch at the same angle or not, or whether one prong is round and the other square. In this problem we have three prongs all having the same angles and diameters, so that the pattern for one will answer for all. In laying out the drawing it is only necessary that one prong be drawn at right angle to its center line $1'B$ in plan, as shown by $1-4'-7'-8-14$. This rule applies to any number of prongs. First draw the profile of the base, as shown in plan by $A-4''-Y$. As three prongs are required, divide the circle into three equal parts and draw the joint or miter lines $A-1'$, $4''-1'$ and $Y-1'$. From $1'$ erect the line $1'-1$ and establish at pleasure the height $a-1$. From $4'$ erect the line $4'-4$ and at pleasure draw the curve $1-4$. Then $1-a-4$ represents the true section on $1'-4'$ in plan. Divide this section into equal parts as shown, and from these points drop vertical lines, cutting the miter line $1'-4'$ at $2'$ and $3'$. With $1'$ as center and radii equal to $2'$ and $3'$ transfer these points to the miter line $1'-4''$, as shown by $2''$ and $3''$. From these intersections erect lines, which are intersected by lines drawn from similar numbers in the section $1-4$, parallel to the base line $4-7'$, thus obtaining the intersections $2'$, $3'$ and $4'$. The curved line $1-4'$ is then the foreshortened miter line shown in plan by $1'-4''$. Now divide the distance from $4''$ to 7 in plan in equal parts, as shown by

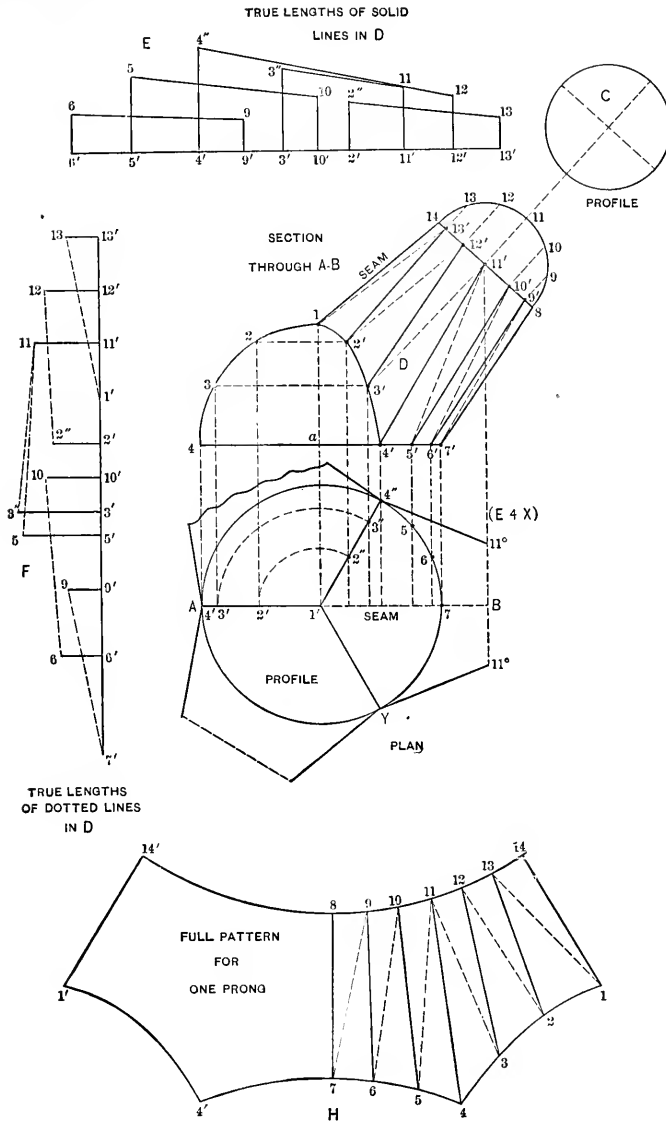

FIG. 204.

4", 5, 6 and 7, and erect lines cutting the base line of the fork at 4', 5', 6' and 7'. *C* represents the profile of the upper opening of one prong. One-half of this is placed in position, as shown on the line 8-14, and the semi-circle divided into as many spaces as there are divisions in the section 1-4 and in the part plan 7-4" or six spaces. Number these spaces as shown from 8 to 14 and draw perpendiculars to the line 8-14 as shown. Now draw solid and dotted lines in *D* as shown, and obtain their true lengths as shown in diagrams *E* and *F* respectively. For example: To find the true length of the solid line 3'-12', place this distance as shown from 3' to 12' in *E*, from which erect the perpendicular 3'-3" and 12'-12 equal respectively to the distances measured from the line *AB* in plan to the point 3" and from the line 8-14 in *D* to the point 12. The

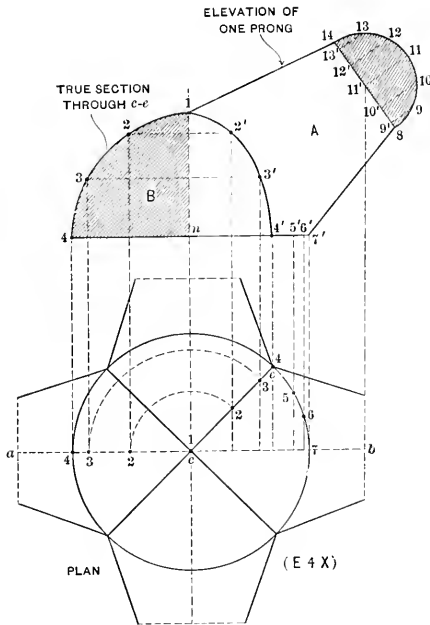

FIG. 205.

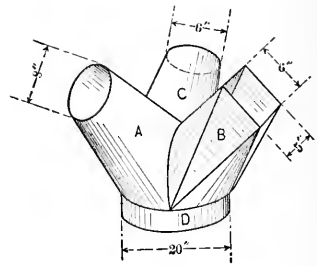

FIG. 206.

distance from 3" to 12 in *E* is then the true length of 3'-12' in *D*. Having found the true lengths shown in *E* and *F* by similar reference letters, the pattern is developed as is shown in *H*. 7-8 and 1-14 are equal to 7'-8 and 1-14 in *D*. The divisions from 8 to 14 in *H* are obtained from the semi-profile in *D*. The divisions from 1 to 4 in *H* are obtained from 1 to 4 in the section 1-4, while the divisions from 4 to 7 in *H*

are taken from the spaces 4" to 7 in plan. The opposite half of the pattern is traced as shown by 8-14'-1'-4'-7.

FIGS. 205, 206 and 207. Develop the pattern for a four-pronged fork, the plan of which is shown in Fig. 205. The four prongs being equal, only one pattern is required. *A* shows the elevation of one prong, and *B* the true section through the miter line *c-e* in plan. This true section *B*, as explained in the preceding problem, can be drawn at pleasure after knowing the height *n-1* and making the distance *n-4* equal to

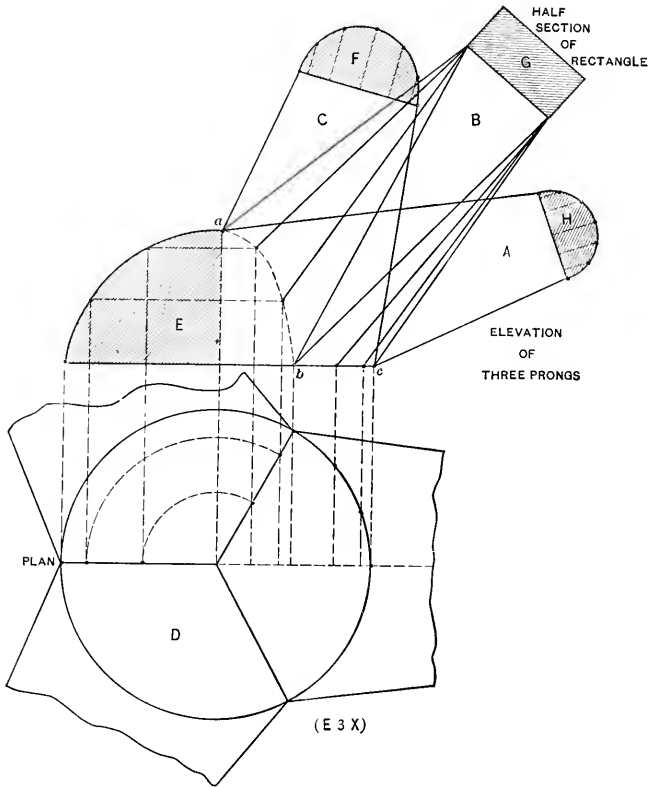

FIG. 207.

any one of the miter lines in plan as *c-e*. The half section is placed on 8-14 as shown. Note that the foreshortened miter line *1-4'* in *A* is obtained by dropping vertical lines from *B* to the center line *a-b* in plan, which are then projected to the miter line *c-e*, from which vertical lines are erected, resulting in *1-4'*. To show how this same prin-

ciple can be applied to unequal prongs projecting at various angles and having different profiles, Fig. 207 has been prepared. Each of the three prongs must be developed separately. Fig. 206 gives a better idea of what we intend to work out in Fig. 207. Let A , B and C in Fig. 206 represent a three-pronged fork each projecting at a different angle, joining a base of 20 inches diameter, one prong to be 6 inches diameter, the other 8 inches and the other 5 by 6 inches rectangular. The plan D in Fig. 207 is first drawn and divided in the usual manner as shown. After obtaining the true section E and the foreshortened miter line $a-b$, the prong A is drawn at the desired angle, and the half section H placed in position, and the pattern for this prong obtained in the same manner, as if all the prongs were to be the same as A . Now using the same miter line $a-b-c$, the prong B is drawn at its proper angle, placing the half section G of the rectangle in the position shown, and the various lines drawn in B as shown, and the pattern also developed as if the three prongs were to be similar to B . Finally the prong C is drawn with the semi-profile F , as before. Thus it will be seen that the miter lines ab and bc remain the same, no matter what angle or profile the prong may have.

PATTERN FOR SHIP VENTILATOR

FIGS. 208 and 209. Illustrates how the patterns are developed for a ship ventilator, or any other form of tapering elbow making a transition from one profile to another. First draw the outline of the ventilator, shown by $AKLB$. The curve LB is struck from R and the curve AK from P . $KLMN$ is a straight piece of pipe having profile as shown by G . The section or opening on AB is shown by the elliptical profile $STVU$ in the front elevation and is drawn by using the rule given in Fig. 8, Part One. Complete the side elevation of the elbow by dividing the curves AK and BL both into the same number of spaces as shown, and draw the miter lines CD , EF and $H\checkmark$. Bisect AB , CD , EF , $H\checkmark$ and KL and obtain a , b , c , d and e . Next complete the front elevation by setting off on either side of the center line SW , the distance WM° and WN° , equal to fM and fN in side elevation. Using X as center, draw the arc TN° in front view, also the arc UM° . The distance between these arcs are used for obtaining the minor axis of the elliptical sections on the various miter lines in side elevation. It should be understood that the arc TN° can be drawn at pleasure, but when once drawn it remains a fixed line. Having drawn the front and side elevations, the method of finding the various sections on the various miter lines is illustrated in connection with Fig. 209, in which 1-7-8-14 is a reproduction of $ABCD$ in Fig. 208. Take a tracing of the half section SUV in Fig. 208 and place it as shown by 1-4-7 in Fig. 209. From the various points $a-b-c-d$ and e in Fig. 208 draw horizontal lines into the front view, cutting the curved lines on both sides at $a'-b'-c'-d'$ and e' . b on DC is represented

in Fig. 209 by 11'. From this point at right angle to 8-14 draw the line 11'-11, equal to one-half the width of $b'b'$ in Fig. 208. Using the rule given in Fig. 8, Part One, draw the semi-elliptical section in Fig. 209. Divide both half sections into equal spaces

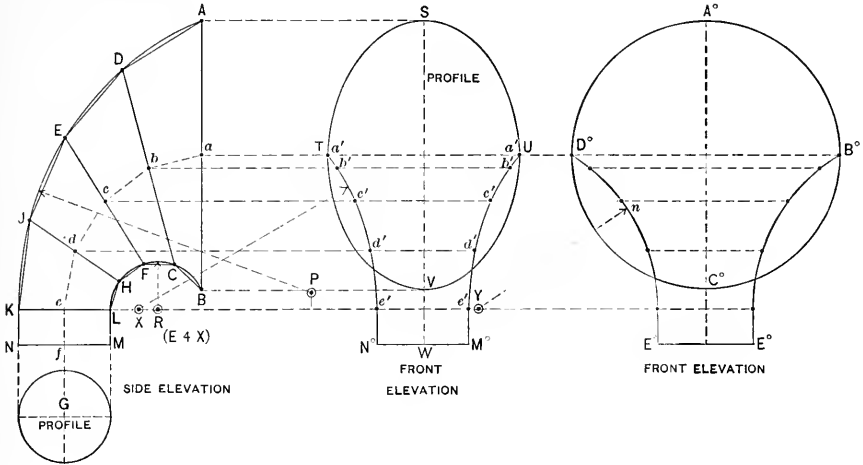

FIG. 208.

as shown from 1 to 7 and 8 to 14. From these points erect perpendiculars as shown, and draw the solid and dotted lines in the usual manner. These lines then represent the bases of sections which must be constructed, the altitudes of which are equal to the various heights in the half profiles, in the same manner as the sections and pat-

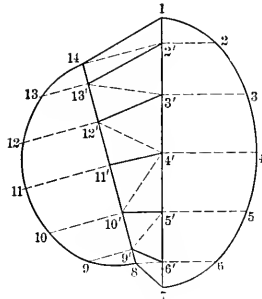

FIG. 209.

terns were developed for the articles given in Figs. 171, 178 and 180. Develop the half pattern for each of the four pieces in Fig. 208, obtaining the true profiles on EF and

$H\tilde{Y}$, as explained in Fig. 209. Using the same size side elevation as in Fig. 208, develop the half patterns only, for a ventilator or elbow, round to round, as shown in front elevation by $A^\circ B^\circ C^\circ D^\circ$. The curved lines $D^\circ E^\circ$ and $E^\circ B^\circ$ are struck with a radius equal to Yn .

PATTERN FOR TRANSITION PIECE BETWEEN TWO ELBOWS AND VERTICAL PIPE

FIGS. 210 and 211. In the former figure X shows the elevation of a five-pieced elbow, three pieces of which as A , B and C are to be joined to a transition piece, as shown in Fig. 211, in which both portions of the elbow are indicated by A , B and C , the profile of the elbow being shown by D and D . The transition piece for which

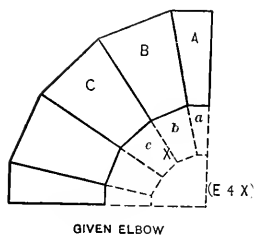

GIVEN ELBOW

TRANSITION PIECE WITH SEMI-PROFILES

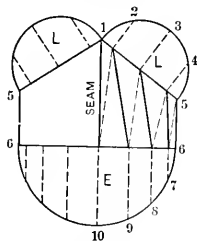

FIG. 210.

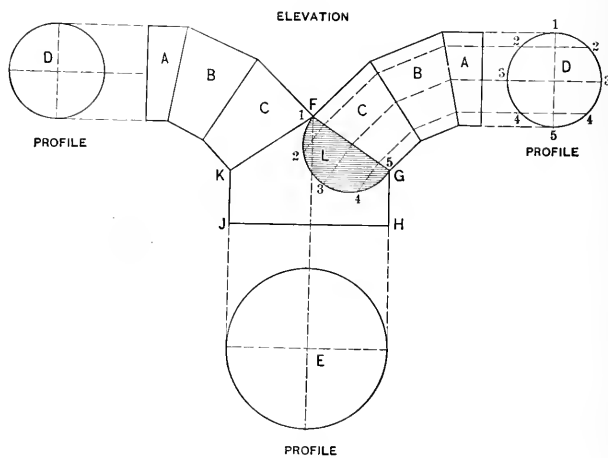

FIG. 211.

the pattern is required, is shown by F , G , H , \tilde{Y} , K , the profile on $\tilde{Y}H$ being indicated by E . The patterns for the elbows need not be developed, as this was clearly explained in Part One. Before proceeding with the pattern for the transition piece, a true section on the miter line FG must be obtained. This is done by dividing the profile D

into equal spaces, as shown from 1 to 5, from which points lines are carried parallel to the lines of the elbow as shown, until they intersect the miter line FG . From these points at right angle to FG draw the lines 2-3 and 4, equal to like numbered heights in D , measuring from the line 1-5. The shaded portion L then represents the true section on FG . To avoid a confusion of lines, take a tracing of the transition piece and place it as shown in Fig. 210. Now take a tracing of L in Fig. 211 with the various points of intersections on same, also a tracing of the semi-profile E , and place them as shown by L , L and E in Fig. 210. Divide the profile L into equal spaces, and one-half of the semi-profile E into the same number of parts, as shown from 1 to 5 in L and 6 to 10 in E . Draw perpendiculars in the usual manner, then the solid and dotted lines as shown. As both halves L and L are symmetrical, it will only be necessary to develop the half pattern with seam, as shown. The true lengths of the various solid and dotted lines are now obtained and the pattern developed in precisely the same manner as explained in connection with Fig. 198.

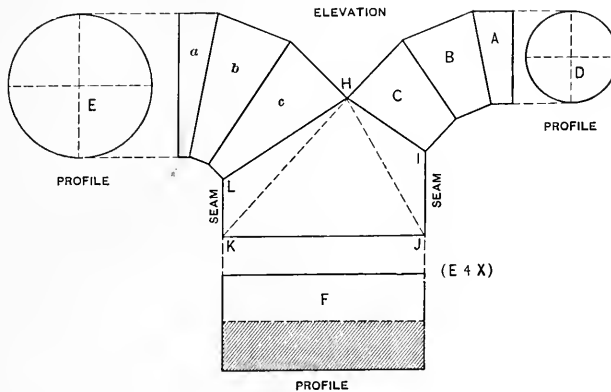

FIG. 212.

FIG. 212. The method given in the preceding problem is applicable to any similar shape or form, as will be seen in the problem now taken up, and in which two elbows of unequal size are to be joined to a rectangular transition piece, as shown in Fig. 212. The elbow ABC is similar to ABC in Fig. 210, and the elbow abc in Fig. 212, similar to abc in Fig. 210. E in Fig. 212 is the profile of the large elbow, and D the profile of the smaller one. F shows the true profile on $\check{Y}K$. In developing the half pattern, have the seam come on LK and $\check{Y}I$. True sections must be found on the miter lines HI and HL , and the half profile of F must be placed on $\check{Y}K$, as shown by the shaded

portion; then following the same rule as in Fig. 210, the true lengths and pattern are obtained.

PATTERN FOR IRREGULAR T-JOINT

FIG. 213. In enlarging this problem, more spaces should be used in the profile C than appear in the illustration. This problem shows the intersection between a transition pipe whose vertical profile on $5^\circ-6^\circ$ is shown by B , intersecting a vertical cylinder D , the profile of which is indicated by C . While a plan view is shown, it is not necessary in the development of the pattern when both halves are symmetrical. After the outline of the T is drawn, bisect the angle $6^\circ-1'-d$ as shown by cde , and draw the line $e-1'$ until it intersects the center line of the vertical pipe at $3'$, from which draw a line to 1° . Now divide the semi-profile C in equal parts, as shown from 1 to 3 on both sides, and erect lines, cutting the lines $1'-3'-1^\circ$ at $1', 2', 3', 2^\circ$ and 1° . For the opening cut in the vertical pipe, take the stretchout of the semi-profile C and place it on $a-b$. Erect perpendiculars as shown, which intersect by horizontal lines drawn from similar numbered intersection in D , resulting in the points of intersections shown by $1^v, 2^v, 3^x, 2^x$ and 1^x in the pattern. The shaded portion shows the developed opening. From the various intersections $2'$ and $3'$ in S draw lines to 6° , and from the intersections $3'$ and 2° in R draw lines to 5° . These lines then represent the bases of sections having altitudes equal to the heights in the semi-profiles B and C . $5^\circ-1^\circ$ and $6^\circ-1'$ show their true lengths. To find the true length of $5^\circ-3'$, place this distance as shown by $5^\circ-3'$ in E ; draw the perpendiculars $5^\circ-5$ and $3'-3$ equal in height to $5'-5$ in B and one-half of $3-3$ in C . Then $3-5$ in E shows the true length of $3'-5^\circ$ in R . E shows the true lengths of the lines in R , and F the true lengths of the lines in S . The half pattern is shown developed by T . The distances $5'-1^v$ and $6'-1^x$ are obtained from $5^\circ-1^\circ$ in R and $6^\circ-1'$ in S respectively. The distances $5'-5$, $5-6$ and $6-6'$ in T , are obtained from the semi-profile B ; the true lengths in T , from the diagrams E and F , and the divisions from 1^v to 1^x in T from similar divisions in the pattern for the opening in the vertical pipe, all as shown by similar reference figures.

FIG. 214. Develop the pattern for the opening in the vertical pipe A in Fig. 214, when intersected by the transition piece C , laying off the pattern on cd . Also develop the pattern for C . B is the profile for A , and D the profile of the opening in the transition piece C . The true lengths are found by using the solid and dotted line in C as base lines, and the heights on one side of the center line ab in both D and B as altitudes, as shown by similar figures.

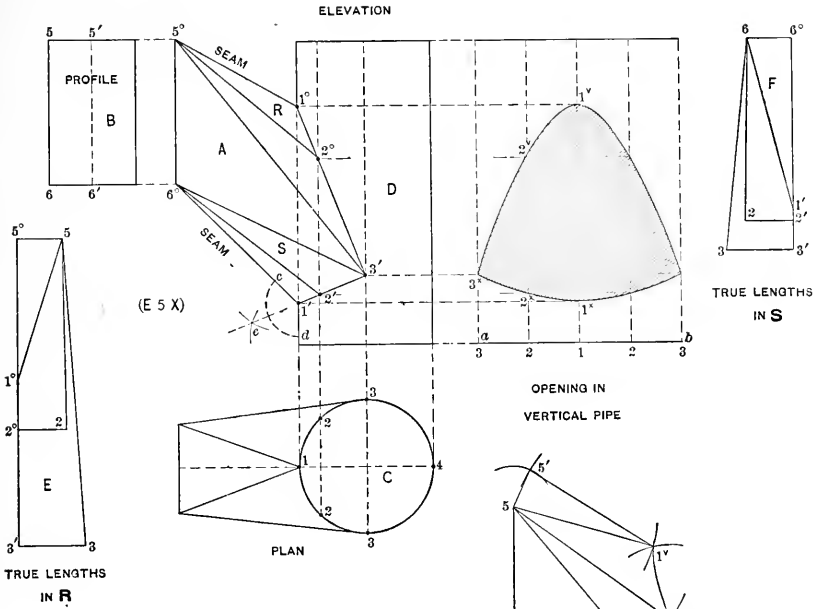

FIG. 213.

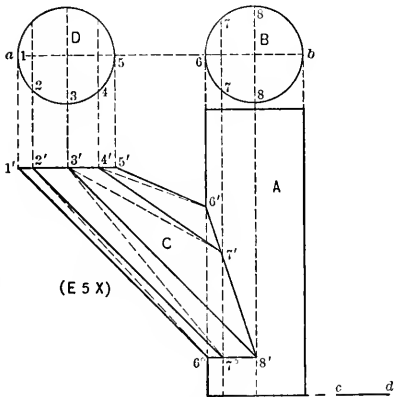

FIG. 214.

PATTERN FOR IRREGULAR TRANSITION PIECE, INTERSECTING HORIZONTAL CYLINDER

FIG. 215. The principles shown in Fig. 215 are applicable to any irregular transition piece such as is here shown, no matter whether the outline is diamond-shape, round or elliptical. The problem here shown represents a diamond boss mitering against a cylinder whose profile is partly shown by AB and is struck from the center C . The side elevation of the boss is shown by $5^{\circ}-5^{\circ}-4^{\circ}-4^{\circ}$. $5^{\circ}-8^{\circ}-5^{\circ}-8^{\circ}$ represents the plan view on $5^{\circ}-5^{\circ}$ in elevation, and $1-4-1'-4'$ the plan view on $4^{\circ}-4^{\circ}$ in elevation. As the four quarters in plan view are alike, it will only be necessary to develop one-quarter, then join two of these to make a half pattern with seams as shown in plan. Therefore divide the quarter circle in plan into equal spaces, as shown from 1 to 4, which points are represented in elevation on the plane $4^{\circ}-4^{\circ}$, as shown by $1^{\circ}-2^{\circ}-3^{\circ}$ and 4° . In similar manner divide part of the curve 5° to 8° also into four parts as in P , as shown by $5^{\circ}-6^{\circ}-7^{\circ}$ and 8° , from which points drop vertical lines intersecting $5-8$ in plan at $5-6-7$ and 8 . Solid and dotted lines are now drawn in plan, which represent respectively the bases of triangles which will be constructed with altitudes equal to the various heights in the side elevation. For example: The true distance of $3-6$ in plan is found by placing this distance as shown by $3-6$ in R . From 6 the vertical line $6-6'$ is erected, equal to the vertical height from the line $4^{\circ}-4^{\circ}$ in side elevation to the point 6° . The hypotenuse $6-3'$ in R then represents the true length of $6-3$ in plan. In this manner the true distances of the solid lines in R and the dotted lines in S are obtained. The distance along $5-8$ in plan does not show its true length because the line $5^{\circ}-8^{\circ}$ in elevation does not lie on a horizontal plane. Therefore this true length on $5^{\circ}-8^{\circ}$ in elevation or, what is the same, $5-8$ in plan is obtained as follows: Take the various points of intersections on $5^{\circ}-8^{\circ}$ in elevation and place them on the line $5'-5$ extended in plan, as shown by similar numbers 5° to 8° . From these points erect perpendiculars, which are intersected by horizontal lines drawn from similar numbered intersections in plan, resulting in $5^{\circ}-6^{\circ}-7^{\circ}$ and 8° in T , which represents the true length desired. $8^{\circ}-5^{\circ}-8^{\circ}$ also represents the quarter opening in cylinder. Having found the necessary true lengths the one-quarter pattern is developed as shown in W . The distances of the solid lines are taken from R ; the distances of the dotted lines from S ; the various divisions 1 to 4 in W' are obtained from 1 to 4 in plan, while the various divisions from 5 to 8 in W' are obtained from 5° to 8° in T . Trace the quarter pattern opposite the line $1-8$ in W' , then $5-5'-4'-4$ will be the half pattern, with seams as shown in plan. Develop the half pattern for an irregular transition piece. The section or profile on the line $4^{\circ}-4^{\circ}$ will be the same as P in plan, but the lower outline will be an

ellipse having a major axis equal to 5-5' in plan, and a minor axis equal to 8-8'; this ellipse to represent a horizontal section on the angle 5°\15° in elevation, against which it is to miter in place of the curve A-8°-B. Use the same size drawing as before, only changing to the angle in elevation and to the ellipse in plan.

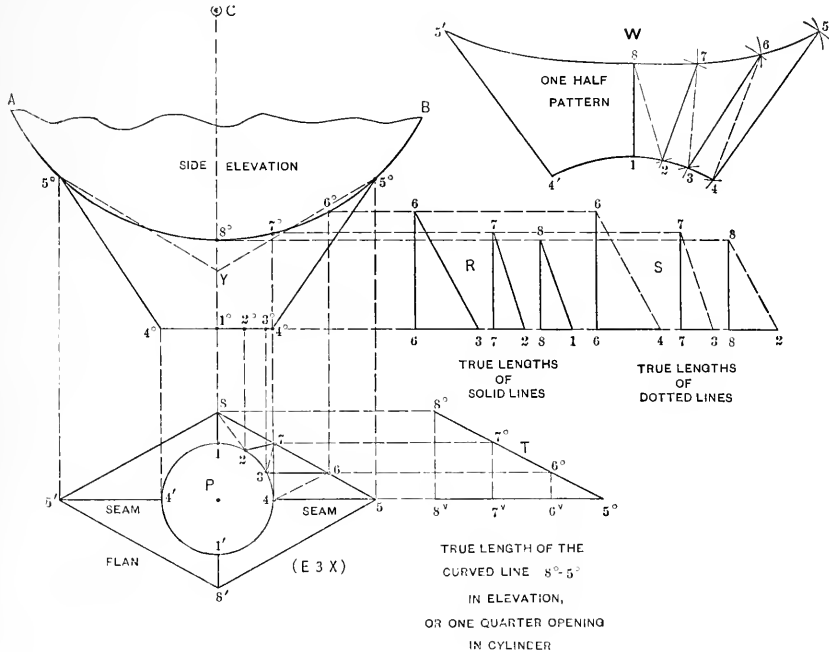

FIG. 215.

PATTERN FOR A BATH TUB

FIG. 216. The principles in this problem are similar to those shown in Fig. 215, only the operations will be reversed when obtaining the true lengths of the solid and dotted lines in the diagrams *H* and *Y* in Fig. 216. In other words, instead of using the plan for obtaining the bases, and the elevation for obtaining the altitudes, as was done in Fig. 215, we will now use in Fig. 216 the lines in elevation as the bases, and the various half distances in the horizontal sections as the altitudes, as hereafter explained. What

method to employ is left to the judgment of the pattern cutter. First draw the elevation of the tub as shown by *C*. In its proper position draw the horizontal section on 1-7 in elevation as shown by *A*, the semi-circles being struck from *a* and *b*, and the straight lines drawn tangent to them. In similar manner, in its proper position, draw the horizontal section on 1'-7' in elevation, as shown by *B*, the semi-circles being struck from *d* and *e*, and the straight lines drawn tangent to them. Now divide the curves in the half profile *A* into equal spaces, as shown from 1 to 3 and 4 to 7, from which erect vertical lines intersecting the base lines 1-7 in *C*, as shown by similar numbers. In similar manner divide the curves in the half profile *B* into the same number of spaces, as shown from 1' to 3' and 4' to 7', from which points lines are dropped cutting the outline 1'-7' in *C*, as shown by similar numbers. The curved outline 3' to 4' in *C* is now divided into equal parts, as shown by 8'-9' and 10', from which lines are erected to the section *B*, intersecting same at 8'-9' and 10'. Solid and dotted lines are now drawn in the elevation *C*, as shown, which represent the bases of the sections to be constructed, and which are shown in diagrams *H* and *J*. Thus the true length of the dotted line 4'-5 in elevation is obtained by placing this distance on the horizontal line in *J*, as shown by 4'-5, then erecting the perpendiculars 4'-4' and 5-5, equal to similar numbered distances measured from the line 1'-7' in *B*, to the point 4', and from the line 1-7 in *A* to the point 5 respectively. The slanting line 4'-5 in *J* then represents the true length of 4'-5 in *C*. As the line 1'-7' in *C* does not lie on a horizontal plane, then *B* does not show the developed section, the same as *A* does on the line 1-7 in *C*. To find this developed section on 1'-7' in *C*, take the various divisions on this curved line and place them on the line *de* extended in *B*, as shown by similar figures 1" to 7" on *FE*. From the various divisions 1" to 7" drop perpendicular lines, which intersect by horizontal lines drawn from similar numbered intersection in *B*, resulting in the intersections 2° to 6° in *D*. A line traced through these points is the half developed section through 1'-7' in *C*. Having the various true lengths, the half pattern is developed as shown in diagram *M*, in which the solid lines are obtained from *H*, the dotted lines from *J*, the divisions from 1 to 7 in *M* are obtained from *A*, and the divisions from 1' to 7' in *M* from *D*. 1-1' and 7-7' in *M* are obtained respectively from 1-1' and 7-7' in *C*, on which lines the seam is located. Use the same size drawing as in Fig. 216 and obtain the half pattern for a bath tub, when the top has a slant line as shown by the dotted line from 1' to 7' in *C*.

PATTERN FOR A FUNNEL COAL HOD

FIG. 217. Shows how the pattern is obtained for a funnel coal hod. The principles in this problem do not differ from those given in the preceding problem. The side elevation A is first drawn, then the horizontal section on $6'-10'$ placed in its proper position as shown by B . In similar manner the section C is placed in line with $1'-5'$. A horizontal section on the curved line $11'-15'$ is now constructed as shown by D , in which a is the center of the semi-circle $b-11-b$; b the center of the arc bi , and c the center of the arc $i-i$. Each of the semi-sections B , C , D are divided into the same number of spaces, and perpendiculars drawn until they cut the various section lines in elevation, as shown by similar reference figures. Note how the solid lines in elevation are drawn, also the dotted lines connecting opposite points. These solid and dotted lines represent the bases of sections, the altitudes of which equal the distances in the various semi-sections in B , C and D respectively, as shown by similar reference figures in the diagrams \checkmark and L , which represent respectively the true lengths of the solid and dotted lines in A . A developed section must now be found on $11'-15'$ in A as shown by E . Take the girth of $11'-15'$ in A , and place it on the center line in D extended as shown in E . Draw perpendiculars as shown, which intersect by horizontal lines drawn from similar numbers in D as 11, 12° , 13° , 14° and 15 in E . A line traced through these intersections will give the half developed section on $11'-15'$ in A . Having found the various true lengths, the pattern is developed as shown in M , in which the distances 5-6, 10-11 and 15-1 are obtained respectively from $5'-6'$, $10'-11'$ and $15'-1'$ in A . The divisions from 5 to 1 in M are obtained from the semi-section C ; the divisions from 15 to 11 in M from the half developed section E ; the divisions from 6 to 10 in M from the semi-section B , and the lengths of the various solid and dotted lines in M from the slant lines in the diagrams \checkmark and L . 1, 5, 6, 10, 11, 15 in M is then the half pattern for the hod A , with seams at $1'-15'$, $5'-6'$ and $10'-11'$. If a full pattern is desired with seams at top $1'-15'$ and back $10'-11'$, it is only necessary to trace the half pattern in M opposite the line 5-6, as shown by $1'-15'-11'$ and $10'$. H is the pattern for the foot F .

FIGS. 218 and 219. Solve the problem shown in Fig. 219, a perspective of which is shown in Fig. 218, being an open top coal hod. A in Fig. 219 shows the side elevation of the hod, B the true section on $1'-5'$, and C the horizontal section on $6'-10'$. a is the center of B , and b the center from which the semi-circle in C is struck. Divide both the semi-sections in the same number of spaces as shown; obtain the various intersections in elevation, and draw the solid and dotted lines in the usual manner. The true lengths of the solid and dotted lines are obtained, by using the various solid

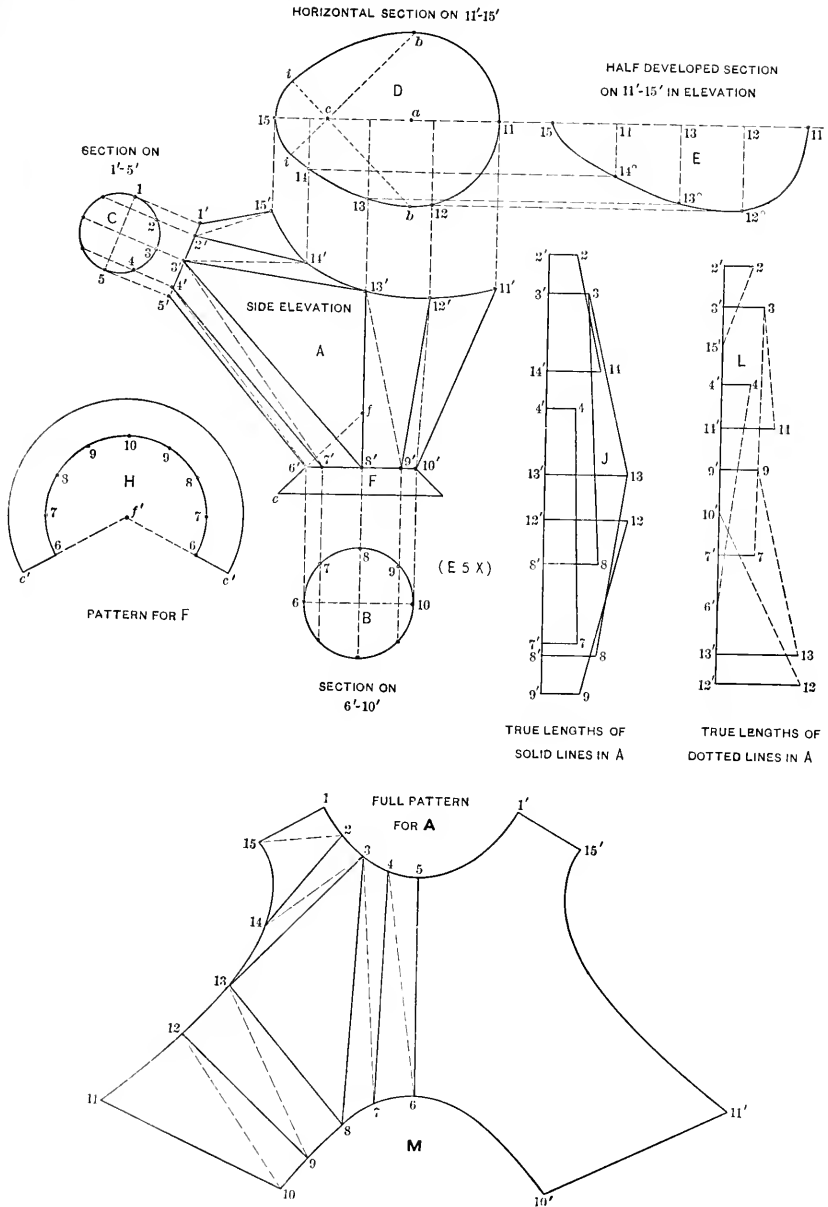

FIG. 217.

and dotted lines in *A* as bases, and the various distances in the semi-sections as altitudes in precisely the same manner as was done in Fig. 217. The developed section on 6'-10' in Fig. 219 is obtained in similar manner as *E* was obtained in Fig. 217.

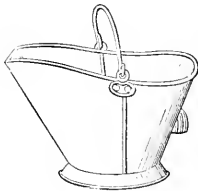

FIG. 218.

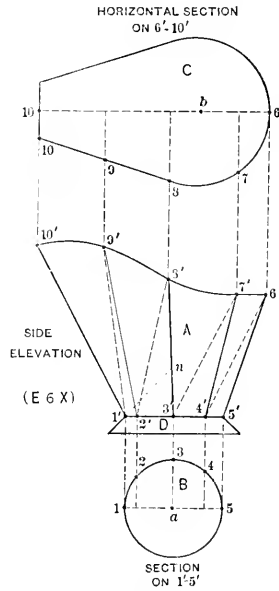

FIG. 219.

Develop the pattern for the hod in Fig. 219 in one piece with a seam on 5'-6' in side elevation. Also develop the pattern for the foot *D*. *n* shows the center from which the pattern is struck, the pattern being obtained as shown in diagram *H* in Fig. 217. In enlarging the problem in Fig. 219 double the amount of spaces should be used in the sections *B* and *C*.

CONCLUSION

The variety of forms arising in sheet metal work is practically unlimited, and many more problems could be furnished. But the principles involved would simply be a repetition of what has already been explained. The course of instruction in which this textbook is used, imparts the basic principles of pattern drafting. Having once mastered the principles, the student should experience no difficulty in preparing patterns for any of the various forms he may encounter in practice.





LIBRARY OF CONGRESS



0 003 318 833 A