

BOOKBINDING
FOR
LIBRARIES

DANA

UC-NRLF



\$B 242 055

LIBRARY
SCHOOL

LIBRARY
OF THE
UNIVERSITY OF CALIFORNIA.

Class

63-73

A. E.



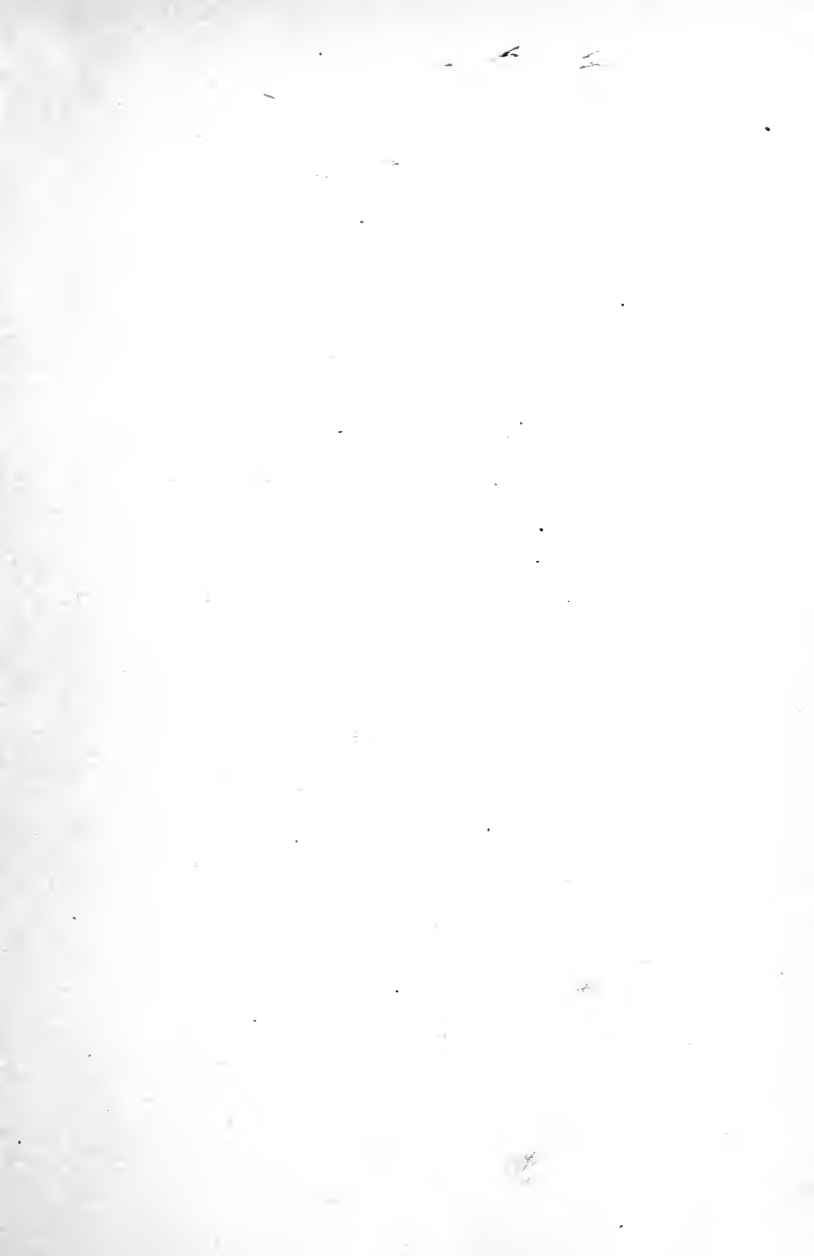

Digitized by the Internet Archive
in 2007 with funding from
Microsoft Corporation



The picture opposite the title-page is a reprint of a page from the volume of plates, made in 1771, to illustrate Diderot's *Encyclopædia*. This page is one of six, each 8x12 ins. in the original, illustrating the article in the encyclopædia on binding.

The picture in the upper part of the plate represents a binder's workshop. The person at A is beating a book. The woman at B is sewing. The man at C is cutting or trimming the edges of a book. The man at D is working a press.

Of the figures below: 1 is a piece of marble on which books are beaten; 2 is a piece of marble of different shape for the same purpose; 3 is a beating hammer; 4 is a sewing table or bench, on which books are sewn; 5 and 6 are balls of thread for sewing books; 7, 8, 9, 10, 11, and 12 are parts of a sewing bench; 13 and 14 are large and small paper folders.



LIBRARY
OF THE
UNIVERSITY
OF
CALIFORNIA

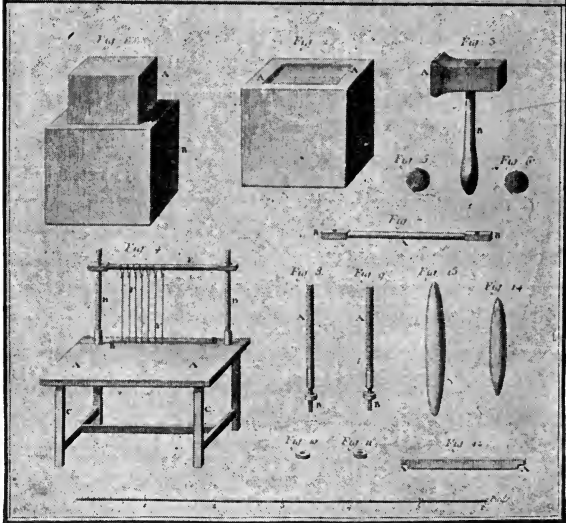
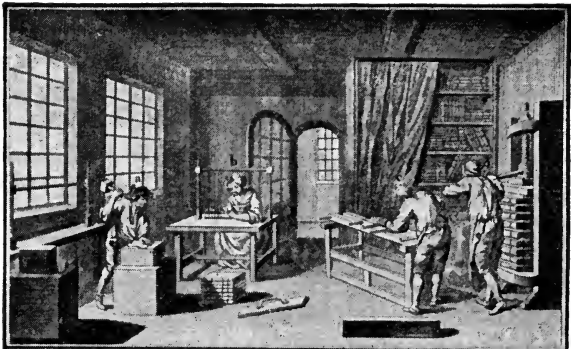

Notes on
Bookbinding for Libraries

By
John Cotton Dana

Librarian Free Public Library,
Newark, N. J.

Revised and Enlarged Edition



Library Bureau, Chicago
1910

Z271
D2
1910
LIBRARY
SCHOOL-

GENERAL

COPYRIGHTED
1910
LIBRARY BUREAU

Naudé On Binding

“The fourth is, to retrench & cut off all the superfluous expences, which many prodigally and to no purpose bestow upon the binding and ornaments of their Books, and to employ it in purchasing such as they want, that so they may not be obnoxious to that censure of *Seneca*, who handsomly reproaches those, *Quibus voluminum suorum frontes maxime placent titulique*; & this the rather, that the binding is nothing but an accident & form of appearing, without which (at least so splendid and sumptuous) Books become altogether as useful, comode & rare; it becoming the ignorant onely to esteem a Book for its cover; seeing it is not with Books, as it is with men, who are onely known and respected for their robes and their clothes, so that it is a great deal better, and more necessary, for example, to have a good quantity of Books, well & ordinarily bound, than to have a little Chamber or Cabinet full of washed, gilded, ruled, and enriched with all manner of nicity, lux and superfluity.”

From John Evelyn's translation of Gabriel Naudé's "Instructions Concerning Erecting of a Library." London. 1661. Chapter 5.

Preface to Second and Revised Edition

In the first edition of this book I said that it ought not to be taken as a final authority, but as a set of suggestions which I hoped would arouse interest in the subject of library binding and lead a few to pursue the subject further. Some of the changes made for this edition indicate that I have followed the topic a little further myself,—I hope with advantage to my readers.

Several chapters are new. There are many minor changes and omissions. The lists have been enlarged and brought into one.

I had looked into the subject of library binding and discovered the ignorance concerning it of American librarians, including myself, before I visited Mr. Chivers' beautiful bindery in Bath, England, several years ago. That visit had much to do with the contents of this little book. Mr. Chivers was quite of my opinion that the only way to induce librarians in America to improve our binding was to persuade us to look into the subject. If the book has led some to do this it has accomplished its purpose. As to the fundamental points in it, they largely come, I am pleased to confess, from England, by way of that bindery in Bath.

At the risk of seeming to speak to commercial ends I quote in effect some of the things said by

Mr. Chivers in one of his circulars, prefacing the quotation with the remark that the point I wish chiefly to make in this book is the advantage of having certain books, when new, bound once for all:

“The following statement is not an exaggeration: A library saves half the cost of new popular books, and of replacements for which much use may be anticipated, if it purchases them in Cedric Chivers’ patent bindings. New books supplied in these bindings are sold as being bound once for all. It is thought that they are so bound as to serve for quite fifty per cent. more issues than will a book purchased in publisher’s cloth, used for a time, and then rebound in the ordinary way. Generally speaking such results and even better results are obtained. Occasionally, however, a book does not come up to these expectations. In such cases it is especially desired that its failure be reported and, if necessary, that the book be returned for examination. The paper used in modern books is of such varying quality that it is sometimes difficult to tell without actually trying what is the best manner of treating it.”

Buy books well bound direct from publishers’ sheets; mend ordinary books very little; rebind them early; watch results; tabulate them, and make use of experience. These are the main themes of this book.

J. C. D.

Free Public Library,
Newark, N. J., May, 1909.

Contents

	PAGE
Description of Frontispiece.....	4
Quotation from Naudé.....	9
Preface to Second and Revised Edition.....	11
Table of Contents.....	13
List of Illustrations.....	15
CHAPTER	
I. Introductory.....	17
II. Binding: the Process Described.....	26
III. The Literary Side of Library Rebinding.....	36
IV. Binding Materials Suitable for a Library.....	41
V. Rebinding for Libraries.....	44
VI. Lettering and Numbering the Backs of Books	53
VII. Pamphlets.....	58
VIII. Magazine Binders.....	61
IX. Repairing Books, General Rules.....	68
X. Repairing Books, Newark Methods.....	74
XI. Repairing Books, Materials and Tools.....	86
XII. Covering Books.....	90
XIII. Leather, General Notes.....	93
XIV. Paper and Paper Making.....	101
XV. Binding Records.....	110
XVI. Binding Records and Notes—Newark.....	112
XVII. Bindery Equipment.....	115
XVIII. List of Technical Terms.....	119
XIX. List of Makers of and Dealers in Bookbinders' Materials, Tools and Machinery.....	161
XX. A Few of the Best Books on Bookbinding, Paper and Leather.....	163
Index.....	169



List of Illustrations

	PAGE
Old Picture of Bindery and Tools.	<i>Frontispiece</i>
Sewing, Drawing Showing Four Methods.....	27
Sewing on Tapes.....	32
Method of Attaching Slips on Ends of Bands to Boards	34
Plates, Two Methods of Inserting Them.....	48
Method of Lacing in Slips on Ends of Bands.....	49
French and Ordinary Joints.....	50
Anatomy of a Joint.....	51
Type Faces Suitable for Lettering.....	55
Type Cabinet.....	56
Backing Boards, metal.....	121
Backing Boards, wood, steel-faced.....	121
Backing Hammer.....	122
Backing Press.....	123
Beating Hammer.....	124
Boards, brass-bound.....	125
Hand Wheel Drive Cutter.....	131
Finishing Presses.....	135
Finishing Stand.....	136
Lettering Pallet.....	149
Flat Polisher.....	151
Rounding Hammer.....	153
Sewing Bench.....	155
Standing Press of Wood and Iron.....	158

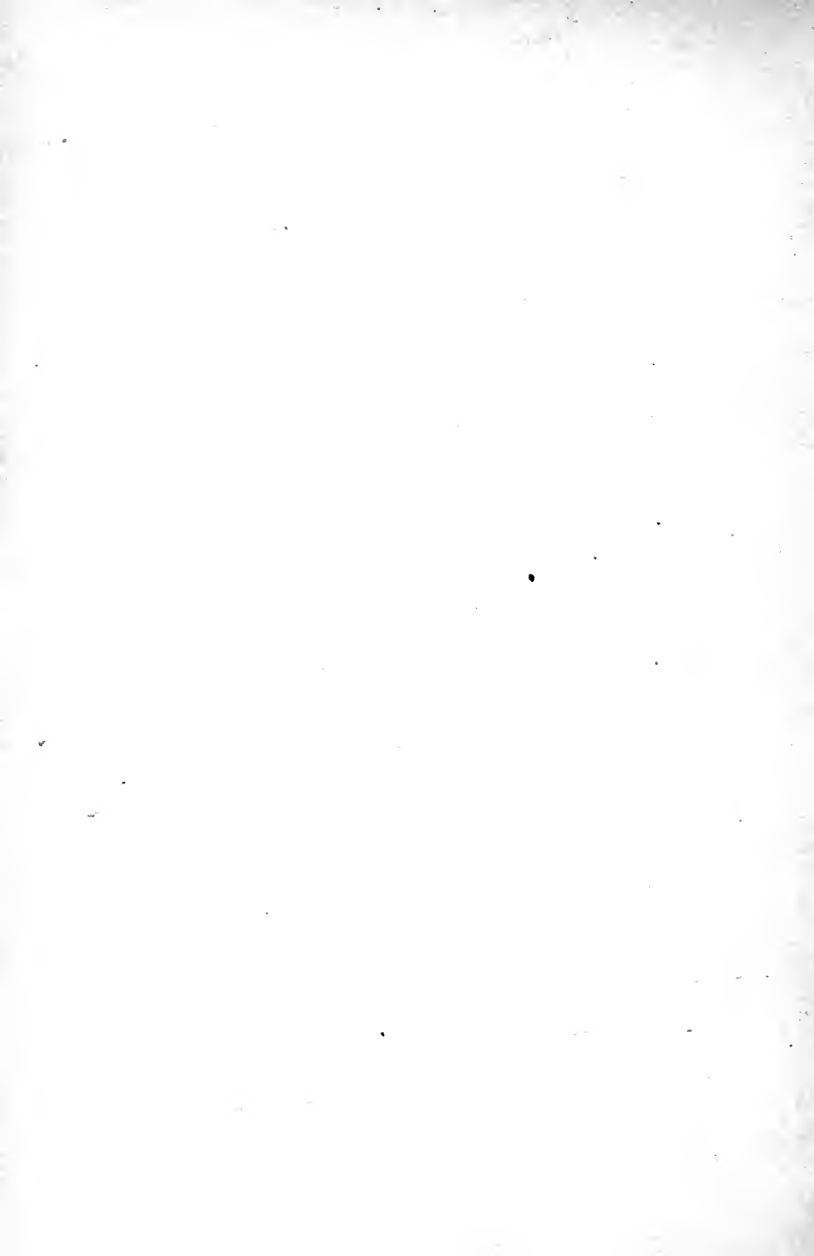



CHAPTER I

Introductory

As the title indicates these notes have been compiled in the hope that they may be of assistance to librarians in caring for the binding and rebinding of library books. They hardly touch upon publishers' binding or the decoration of bindings. The suggestions and advice they give should not be taken as final, for the binding and rebinding question is not yet settled. They may help some to carry out more successfully their own inquiries and experiments. If good binders were more common librarians would need little of the information here briefly set forth. But under the present conditions of the book-binder's art in this country librarians themselves must often furnish considerable expert knowledge, if they wish their work well done.

I have refrained from going much into the details of the process of binding. The details can only be made clear by means of illustrations, and have already been most admirably set forth in Douglas Cockerell's book. I have tried to draw attention to the important points. The librarian ought to know good results when he sees them, or at least when he tests them on his books; the details of every step he can learn if he will, by a little practice and

a good deal of observation. No librarian should try to bind or to conduct personally his own bindery. Binding is a special trade, and skill and speed in it come only by long practice. The librarian cannot become a skilled binder. He should become familiar with the results of the binding he gets by a study of his books. If he finds they do not wear well, but rot, break or show loose pages, let him keep a few statistics, and if he learns he is wasting money on cheap work or poor material, let him change his material and his processes, and perhaps his binder. I hope this book may lead some to test the work they are now getting, and may help some to get more satisfactory workmanship and more enduring materials. It is not a guide to the craft of binding. To get good binding, go to a good binder; to learn about the binding craft, practice it and read Cockrell; to discover if your binding is good, watch it and gather statistics of its wear.

Much of the information, many reports of experiences and many suggestions will be found in the lists of leathers, etc., and definitions of terms used in binding. It seemed unwise to repeat them as part of a connected text.

In considering the subject of economical binding and rebinding for libraries, we find that we are entirely without standards. We have no figures for comparisons. Librarians have, save in a very few cases, made no study of the comparative value of bindings, either of original cloth or of the rebindings they have had put on their books. If a few

librarians would note the number of times books can be issued without rebinding after they are received in the original publisher's cloth, and how many issues they will stand after they have been once, or twice, rebound, they would, in a few months, have data from which they could draw helpful conclusions in regard to the comparative value of bindings and rebindings.

The test of a binding, whether publisher's original, special from the sheets, or a rebinding, lies, for ordinary lending books, in the ratio of its cost to the number of times the book it covers is lent for home use before being discarded. This ratio has rarely been systematically noted.

To the inquiry, does the method of rebinding which my library now employs give the best possible return for the money spent? most librarians must reply that they do not know.

Reference and college libraries are often also much in the dark. The continued quite general use for permanent bindings of a leather which tests have shown will not last over 25 or 30 years at the most is an evidence of this.

In England, as is well known, a good many years of careful observation and comparison of experiments have led a large number of librarians to the conclusion which some American librarians also accept, that it is the part of sound economy to have books carefully bound directly from publishers' sheets, even though the prices of such bindings seem at first unduly high.

I sent a letter of inquiry to a large number of libraries asking for detailed information about the wear of books in publishers' bindings and in the one or more rebindings which were placed on them. Replies were received from 18 libraries, giving brief life histories of 74 books. Definite conclusions cannot be drawn from these reports, as librarians differ much in their ways of treating books. Some rebind them as soon as they show serious signs of wear; others keep them in circulation long after they have begun to go to pieces. But the figures indicate that it would pay these libraries, as it probably would all others, to get most of the books which are to be subjected to much handling strongly bound direct from publishers' sheets.

The reports show that 74 books cost, including first price, rebinding and labor of handling for rebinding, an average of \$1.38 each; that they were lent an average of 79 times in the two states, new and rebound; and that they were out of use an average of five weeks while being rebound. A book of a nature similar to those reported on, well-bound from publishers' sheets costs about \$1.50; can be lent from 100 to 150 times and loses no time in being rebound.

Of these books 52 were rebound a second time at an average cost, including labor in preparation, of 40 cents; were out of use an average of five weeks; and were lent an average of 43 times each in this second binding. The complete history of the books a second time rebound is as follows:

First cost	.95
Cost of first rebinding	.36
Cost of time in handling	.07
Cost of second rebinding	.33
Cost of time in handling	.07
	<hr/>
Total cost	1.78

Times lent in publishers' cloth	32
Times lent in first rebinding	47
Times lent in second rebinding	43
	<hr/>
	122

Time out of use first rebinding	5.5 weeks
Time out of use second rebinding	5. weeks
Total time out of use	10.5 weeks

These figures do not tell the whole story. The book bound strongly and flexibly from publishers' sheets is from the first more convenient to handle and pleasanter to read, and usually looks better throughout all its one long life than do, on the average, those books which twice or thrice in their histories get into a broken-backed, loose-leaved, generally disreputable condition. Furthermore, and this is most important, a book is most wanted in a library when it is new; if sent out to be rebound for five and a half weeks after it has been lent 32 times it is out of use just when it is most in demand; and the library loses in its effectiveness—that is, in the service it can render its public for the money expended—much more than the mere difference in the money cost of the two kinds of binding would indicate. The durable first binding gives us a book which can be in constant service from 100 to 150 times from the

day it goes to the shelves, just when it is most needed. A book once or twice rebound in the first few months of its life is a special source of annoyance—the paradox is permissible—by its very absence.

Table of life histories:

Library	No. of books reported on	First cost of books	Times lent before rebounding	Cost of rebounding	Weeks out of use	Cost of handling	Times lent in rebounding	Cost of 2d rebounding	Weeks out of use	Cost of handling	Times lent in 2d rebounding
1	9	9 00	30	4 50	6		40				
2	2	2 00	40	70	8	20	70				
3	5	3 25	19	2 50	6	50	23				
4	10	9 80	15	4 50	4	60	25	4 50	8	60	32
5	1	1 00	28	35	4	12	50				
6	10	10 00	28	2 50	6	30	31	2 50	6	30	22
7	4	4 00	20	1 80	4	40	25	1 80	4	40	15
8	1	1 00	70	54	10	08	100				
9	1	1 00	75	35	10	08	45	54	10	08	100
10	3	3 00	29	1 05	2	30	80	1 05	2	30	115
11	1	99	37	40	6	12	36				
12	3	2 70	35	1 20	6	36	40				
13	1	96	18	35	6	10	64	35	6	10	32
14	2	1 80	22	50	5	16	14	70	5	16	14
15	4	2 72	19	1 40	4	32	19	1 40	5	32	14
16	15	15 00	45	3 75	4	1 50	60	3 75	4	1 50	50
17	1	1 00	15	25	4	06	60	15	4	06	50
18	1	98	30	35	4	08	62	35	4	08	28
Totals	74	70 20	575	26 99	99	5 22	844	17 09	58	3 84	472
Averages for each Book		95	32	36	5½	07	47	33	5	07	43

In the Newark library an examination of 56 books, chiefly novels, from 15 or 20 different publishers, shows that on the average they were lent in publishers' binding only 25 times each before being rebound;

and that 42 books in the juvenile department were lent in the publishers' binding an average of only 17 times each.

In bindings and rebindings one of the most essential things to be secured is ease of opening. A book that opens out easily, and lies flat without being pressed or held in position, will probably keep clean and whole for more than twice as many lendings as one that is held together tightly at the back. As a great many of the library books which call for rebindings have to be trimmed at the back and overcast, it is essential that the overcast sewing be of a flexible nature, one that permits of the easy opening of the book. Probably few of the factors in book construction and book injury have been more effective than the tight binding, held open with difficulty, which is produced by nearly all of the current overcasting or whipstitching.

Another point that cannot be too strongly insisted on is that books not only differ from one another in their natures and so require different treatment in binding; but also differ in the use they are to receive, and require different bindings on that account.

It should be understood that bookbinding is a craft in the best sense of that word. To bind a book well calls for good judgment and care at every step. The librarian can draw up schedules with infinity of detail, and make them as correct as he may please, basing them on experience without end; and the binder, so far as material and processes are concerned, may seem to follow these specifications exactly, and

still may produce poor bindings. To secure a good binding the spirit of the binder must go into it. In drawing the thread, in paring and placing the leather, in applying the paste and glue, and in every other of the many processes involved, the man without good will, as the man without skill, can spoil the whole binding. Librarians should learn to esteem bookbinding highly. It is a craft which lies close to them. It is preëminently their business to encourage it to grow in excellence. They should develop their local binder's interest in his calling, stand by him, urge him on to better work, and pay him adequately for it.

One may frankly say that the character of binding done in nearly all libraries in America has been, up to the present time, a discredit to the library profession. We owe it to ourselves to take up this craft and do what we can to elevate it.

One objection sometimes made to bindings of the highest grade is that they last too long; and after the book is too greatly soiled and tattered within to be longer kept, the binding itself still holds, showing that more care has been put into its construction, and consequently more cost, than it needed. The objection needs only to be stated for its absurdity to be seen. The thorough binder, the skilled craftsman, adapts his binding to the book and to the use, as far as he can judge of it, which it is to receive.

He binds each book so well that it will hold together to the end of time; or until its paper fairly drops to pieces. He can issue with each volume no guarantee

that it will not receive more than its proper baptism of dirt from careless borrowers long before the paper in it begins to give way and fray out. The binder's obligation is to bind the book well. It is the librarian's business to see that the book is, as to its interior, well treated. As to its binding lasting too long, why should the librarian concern himself about the shell after the kernel is eaten? It should be noted again, however, that a book well bound, opening easily, and lying open without pressure from fingers or thumbs, keeps clean many times longer than one that opens hard.

The sum of all my observations is, the best is the cheapest. If a book is worth binding let it be bound by the best man available. If possible, buy books so well bound from the publishers' sheets, that they will never need to be bound again.

CHAPTER II

Binding: The Process Described

Books are now printed in large sheets from 4 to 64 pages at a time. In many cases paper is drawn from a roll (as it is in the printing of a newspaper), printed on both sides in large sections of 64 pages, and cut and folded as it leaves the press. These sheets, of several pages each, after being printed, are gathered into a complete book, sometimes by a machine, and are then sewn together by a machine. This machine for sewing is a comparatively recent invention. In most cases sewing done on a machine is not as strong as the old-fashioned hand sewing. The sections, or signatures, or folds of the book, as the several sets of several pages each are called, are caught together only by thread; strings or tapes are not used. This sewing is then reinforced by a piece of cloth, usually thin, cheap muslin, or poor super, which is pasted over the back and allowed to extend a little way down each side. But sewing on a machine can be done with strings added and made very strong.

Covers for books are now made by machines into which are fed pieces of cardboard and a roll of cloth. The machine cuts the cloth into the proper size, pastes it and folds it over the boards into a cover,

leaving a loose place between the two boards to be filled by the body of the book. This cover is then printed in a machine much like a printing press; the gold of the title on the back or sides or both, and the colors or blank impressions, for ornament, all being impressed on it with great rapidity. The completed cover, called a case, is then pasted to the

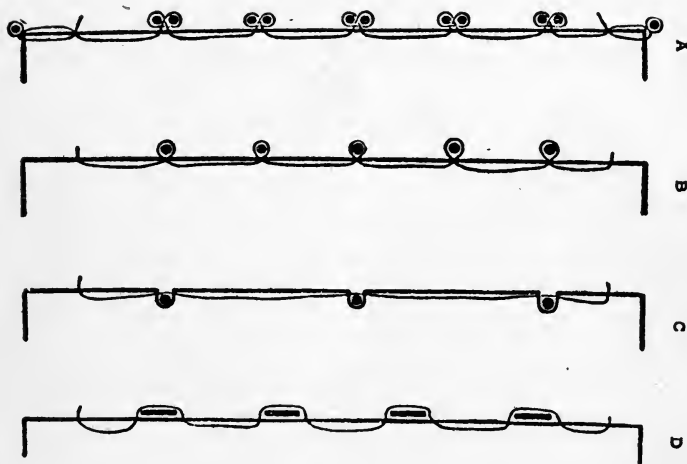

Sewing

- A Section of Fifteenth Century sewing on double bands with head and tail bands.
- B Section of modern "flexible" sewing round single bands.
- C Section of ordinary sewing with sunk bands.
- D Section of tape sewing advocated for cheap work in place of C.

From report of the Committee on Leather for Bookbinding
 Edited for Society of Arts. London: Bell & Sons, 1905.

sides of the book. A book thus bound has nothing to hold cover and inside together save a strip of thin muslin, with a strip of paper which goes over it, passing from the back of the book to the inside of the board covers. This strip grows weak after a little use and frequently breaks, or pulls away from the cover, or from the back, or from both. Books printed on cheap paper and folded and sewed and bound by machinery in the manner thus very briefly outlined can be produced and sold at present for 10 cents each, or even less.

Books printed with more care, on better paper, with a better quality of cloth on the cover, and a more elaborate title in real gold instead of some cheaper imitation of it, books, that is, like the novels issued by the better class of publishers, can be produced in quantities of from one to three thousand, for from 15 to 30 cents each. Few of the novels put on the market today cost the publishers, for their making alone, as much as the latter price. To this must be added a royalty to the author, generally 10% of the retail price, the cost of the management of the business and the advertising. In the case of small editions, one or two thousand, this brings the original cost of the average work up to 50 or 75 cents. Suppose this book to be offered at retail at \$1.25. There must then be deducted from this retail price the discount to the jobber, 25 to 40 + 10%, and the royalty, and the advertising, and the cost of production, etc., leaving a profit to the publisher of from 5 to 20 cents on each volume. A well-made

and widely advertised novel which does not sell more than a thousand copies is not a very profitable product for a publisher to put out.

The school text-books issued by the more reputable publishing houses are generally very well made. They are printed on good paper, usually rather highly calendered, with good ink, are bound with extra care, and have good material in their covers. The competition between school book publishers makes it necessary for them in self-defense to produce books which will wear well in the hands of the average pupil.

Up to a few years ago all books were sewn by hand, the covers were made by hand, and hand work was employed in putting book and cover together.

The process of sewing by hand may be briefly described as follows: Two or more strings or tapes are stretched between the edge of a board and a stick held horizontally above it by two uprights. The book folded and ready for sewing, after having been either pressed or beaten with a hammer to make it lie smooth, is held in a vise and two saw cuts are made in the back at about the same distance from each other and from the ends. Two smaller saw cuts are also made in the back of the book, one between each of the larger ones and the opposite ends of the back. The first signature—the fold or section made of a large sheet folded—of the book is laid on the board so that the larger saw cuts are opposite the two strings. A thread is passed through the small cut at one end, into the middle

of the fold, then out again by the first string, around the string, and in again to the middle of the fold, then along the inside of the fold to the next string, around that string, along inside the fold, then out again at the other small cut. The second signature is then laid on top of the first. The thread is passed into the small cut, along and around the two strings, as with the first signature, and out at the other end, where it is tied to the end of the thread which has been left sticking out of the first saw cut for this purpose. This process is continued until the book is all fastened together and to the strings. As the sewing goes on, the several signatures are caught together at the smaller holes at each end by passing the thread, as it comes out of the hole, down and under the loop made by the passing of the thread between the two signatures previously sewn. In the case of a book containing a large number of signatures the thread does not extend the whole length of each fold, but passes from one to another as it goes the length of the book, gathering on two signatures at once. Sometimes, by using four strings instead of two, the string is made to pass through and to sew on three signatures at a time. Examples of this two-on and three-on method can be seen in almost any large book bound prior to 15 or 20 years ago. In very careful binding by hand in the early days of book-making, the strings were not set into saw cuts, but were simply laid across the back of the book. The thread came out of the signature and passed around the strings, and went in again.

The strings, with the thread thus wrapped around them, made a welt across the back of the book. These welts, when covered by the leather of the binding, showed as raised bands. These raised bands are imitated by pasting bits of leather on the back in much so-called fine binding today. In some cases the old process is employed and the bands have a real reason for existence. Books are sometimes sewn on tapes or strips of vellum. These, laid across the back, sometimes make ridges which are treated as bands in the completed book.

In old bindings, to give the book a better appearance at top and bottom, what is called a headband was put on with thread, the thread passing through the signatures and from one signature to another in such a way as still more securely to hold these together. Today the headband is still used; but usually it is simply pasted in and is little more than an ornament. Sometimes the book's back is still further reinforced by pasting or gluing to it a piece of vellum, leather or heavy cloth before the process of putting on the cover begins.

Set rules for sewing books should not be laid down. Each book is treated by the skillful binder, or should be, in accordance with the character of its paper, the number of inserts, the thickness of the paper, the size of the signatures, the size of the leaves, the use it is to receive, and other facts. The good binder binds each book well according to its kind.

After the book is properly sewn, the strings on which it is gathered are cut off a short distance from

the sides. Pieces of cardboard are cut of the proper size for a cover. The ends of the strings are laced into them or fastened down upon them with paste

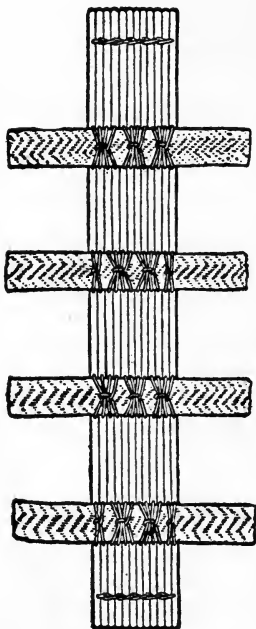

Showing a Method of Sewing on Tapes

The catching up of the alternate groups of threads as they cross the bands renders the sewing firmer. There are other methods of achieving this end.

From report of the Committee on Leather for Bookbinding
Edited for Society of Arts. London: Bell & Sons, 1905.

or glue. The leather for the cover is then pasted or glued to the back and the outside of the boards. The ends are turned over the boards and at the top and bottom of the book are turned down and pasted to themselves, thus forming a roll or crown which lies up close to the headband. The sides are then covered, if the book is not to be bound in full leather, with cloth or paper or other material. The outside sheets of the books, called end-sheets, are then pasted to the inside of the cover and the book is practically complete.

The back of the book is always covered with glue after the sewing and before the leather or cloth is put on. This glue is thin and hot, and is put on to hold together the backs of the signatures. In rounding, the binder manipulates the book with the hands, and taps it with a hammer until the proper shape is secured. This is done after the coat of glue has been applied. In edition work this is done on a machine. In backing the book is held between two metal, or metal-edged, plates close up to the back, the back having been stiffened previously with a coat of glue which has not set very firmly; and with a hammer the backs of the signatures are pounded down and out, making a slight ledge or groove along the outer edges against which set later the boards of the covers.

If the book is to be tight back the cloth or leather is glued direct to the backs of the signatures thus rounded, though often a thin piece of cloth, super, is first glued on, extending over onto the sides. If

it is to be loose back a double fold of paper is attached to the back, one sheet to the back and one to the cover material. The leather or cloth then stands out from the book, when it is open, being attached to it only at the joints. It is in loose back binding, as said above, that cloth or leather is sometimes glued fast and with great care to the back before the cover goes on, thus taking the place of the leather of the cover in the tight back book. In the best binding this backing extends over through or past the joint and onto the sides or covers; and is also firmly

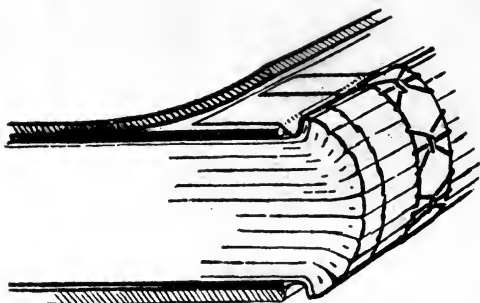

Showing Method of Attaching Tape Slips or Ends of Bands to a Split Board Leaving a "French Joint"

From report of the Committee on Leather for Bookbinding.
 Edited for Society of Arts. London: Bell & Sons, 1905.

attached, at the joint, to the leather of the back. In the Newark library we use for this a thin soft muslin of the best quality.

This description of the process of binding is a suggestive outline only. Enough has been said,

however, to show that the books sewn by hand and fastened carefully to the cover as described will, if properly made, wear much longer than a book bound by machinery, if bound as above described. But, just as a machine properly handled can produce paper of greater uniformity of thickness and of a quality superior in many respects to the best hand-made paper, so the machines used in binding can, if properly handled, bind books even more strongly than can any save the most careful workman. The possible differences between machine-made books can easily be noted in the cheap novels of the day, which are poorly bound, and well-made law books and encyclopædias. These latter are often faithfully put together and will stand almost as much wear as any books ever produced.

CHAPTER III

The Literary Side of Library Rebinding

After satisfactory materials and methods of binding for a library have been discovered and adopted, there still remain many questions which can be well answered only by one having a wide knowledge of books. Nor is a general knowledge of books alone enough to qualify one to answer wisely these questions. Close acquaintance with the library's policy in regard to book-saving and book-buying and of its attitude toward the demand for popular and ephemeral fiction; knowledge of its reference work; of the amount of handling its books receive by the public, and of its financial condition and policy—all this and much besides the person in charge of binding should have before she can make wise decisions. And particularly she needs knowledge of paper, editions, prices and similar matters.

Take fiction for example. More than half of the binding bills of most free public libraries are probably chargeable to novels. One of these comes to the hands of the person in charge of binding in such condition that at the first glance it seems desirable to rebind it. Let us suppose that it is still in publisher's cloth; is quite soiled outside, but still fairly clean within; that the cover has parted from the

book in front; that several leaves are loose and two of them frayed at the edges; that at the back the outside sheets of several signatures are nearly worn through or broken; and that the label is off. Should it be rebound; or what should be done with it? Before deciding its fate, questions like the following must be answered.

If this is not the only copy of this book now in the library, are the other copies in good condition?

If they are, can the library spare this copy because the demand for this particular title is past? And is it not better economy to throw it away or sell it—as it will probably never be wanted again—than to spend money in binding it?

That is to say, if it is bound, will it not stand idle on the shelf?

If it continues to be somewhat popular, and this copy would get some use if it were replaced, still, is it a book the use of which it is the library's policy to encourage?

If not, has it not served its purpose and should it not be put away, rather than entail on the library another expense item in cost of binding?

If it is the only copy in the library, is it a book the library wishes to retain or has it been in effect on trial, and has proved not to be worth keeping?

If so, would not the binding of it be a use of money far less justifiable than its original purchase?

Or is it perhaps of interest now simply as a part of the history of fiction and so still worth keeping?

But, if kept for this purpose, does it need binding

at all? Will not a little mending make it hold together sufficiently well? Perhaps the best plan would be to reclassify it for the literature section, wrap it in paper, mark the wrapper, and put on the shelf.

If it is a good book, in constant demand, the question is still not a simple one. Is it on poor paper, so poor that in our style of rebinding it will last but a short time? If so, would not a new copy be a better investment than the rebinding of this one?

If the paper is good enough for rebinding, will it stand mending and further wear without making its ultimate binding very difficult?

If there are other editions of this book obtainable, does this sample indicate that this particular edition is the best one to buy hereafter?

These and many other questions confront the librarian every time a book, of any kind, comes up for binding. Because they are not wisely answered the shelves of every library show examples of the unwise expenditure of money. To take a specific example in this same field of fiction. The library has several sets of Cooper. In each of them is the Chainbearer. Consider any one of the library's copies of this book: No one reads it. But mere shifting on the shelf gradually wears it out. It goes through the bindery, and, being by Cooper, and a novel, it is bound, in the same style as the Spy which happens to go with it, in half leather. The Spy is used; the leather on it keeps soft and pliable and

wears a year or two, until the book is too dirty to keep it longer. But the Chainbearer stands untouched and its leather hardens and breaks. It must be bound again within three or four years, even though it has not been lent once in that period. If it had received a plain cloth binding, that binding would have cost less and lasted indefinitely. If it had been thrown away the library would have been the gainer.

The problem is not less complex when books in classes other than fiction are up for consideration. Many of them are rarely used; why rebind them at all, no matter how broken? To tie a string about them or to wrap in paper and mark them would often be wiser economy. Often they are single volumes from long sets, an edition, for example, of some history bound about 1800. The binding is calf. In rebinding, to match the set is very unwise, for all calf now on the market will rot in a few years. It must be bound, let us suppose, as it is occasionally called for; yet it will not, like a popular novel, wear out or become unbearably dirty in a half century.

Shall it be put in morocco? This would be a mistake, for it is doubtful if present-day morocco will last 50 years, probably not half that time. The only alternative is cloth, and that with no leather title label on the back. One of the best things is, for a large book, heavy duck back, light gray or light green, lettered in printers' ink, with sides of any good book cloth. This spoils the looks of the set. Moreover, the cloth catches dust and dirt, and grows

soft and flabby. But it is today one of the few safe bindings. If the book is small, full art canvas or imperial morocco cloth is better.

So, as I have said, paper, leather, cloth, sewing, joints, gold, and many other things the librarian must know; and to these must add knowledge of literary values, popularity of books and authors, editions, prices and a score of other things before he can be sure, if he ever can be sure, that he is really binding economically, in the long run.

CHAPTER IV

Binding Materials Suitable for a Library

The Newark Library has tried many experiments in the choice of materials. It finds that thin, imported, acid-free pigskin, first used in this country by Mr. Chivers, is the best material for backs. It wears well; does not rot; is easily manipulated and takes gold lettering well. A disadvantage is its tendency to darken with handling. It works well on books of all sizes and all kinds, whether they are handled much or not.

Morocco, if tanned so that it will not rot, is more expensive than pigskin. For the finer books it is better than pigskin as it preserves better its appearance under much handling.

Cowskin is good for books which are to be much handled and are likely to be worn out and discarded within five years. Only the best quality should be used. Dark red is usually preferable to light red or brown. It costs less than pigskin.

English Imperial Morocco cloth makes a good full binding for books that are not to receive much wear. It cannot be lettered easily, and if much handled soon looks dingy at the top and bottom of the back and along the joint and at the corners.

Dark blue art canvas, the kind in which both

warp and woof are dyed blue, makes a serviceable and inexpensive full binding. It can be recommended for books which are to be handled but little.

Large volumes like periodicals and society proceedings should have backs of gray or light green duck, with black letters, and sides of art canvas or morocco cloth.

Newspapers should also have backs of duck. The sides may be covered with paper, but art canvas or art vellum is better.

If newspapers are to be consulted often they should be carefully bound of course. But in a great many libraries it is wise to tie most newspapers up in flat packages instead of binding them.

For the sides of books, bound with pigskin or morocco backs, which are to be much handled the Newark Library has found nothing as good as keratol, elsewhere described. For books which are not to be much handled, morocco cloth is excellent. On books which are bound with an eye to their beauty,—curios, rarities, books to be exhibited, etc.—Newark uses three-fourths morocco with sides of paper or of cloth of appropriate color.

The joint committee on printing of the House of Representatives, Washington, D. C., made an investigation in 1907 of several binding materials. This investigation was made with special reference to the binding of the publications of the United States government. It included the subjects of endurance, wear, tensile strength, tendency to absorb moisture,

readiness with which attacked by insects. Incidentally other qualities were considered.

An outcome of this investigation was the publication by the Bureau of Standards, Washington, of specifications for bookcloth for binding depository sets of public documents. The specifications state that the cloth shall be from first quality staple cotton, uniformly woven and of the grade known as firsts. The surface shall be smooth and hard and show no tendency to stick when folded upon itself. Further specifications cover the strength of the material, its tendency to absorb moisture, its resistance to mold and insects and other characteristics.

These specifications may be used by all librarians in selecting cloth for ordinary library binding. The Bureau of Standards will make tests according to the specifications for any library, charging a fee for the work. The cloth which conforms to these specifications is a smooth cotton fabric similar to that used by the best law book publishers in this country, and to the duck mentioned above. It is much heavier than ordinary publisher's book cloth.

CHAPTER V

Rebinding for Libraries

Libraries differ as to bindings in their needs and in their possibilities. Books differ even more. No library can or should exactly follow any one style in its rebinding work. I add, however, the following directions for ordinary, much-used 12mo volumes, in the hope that they may be found suggestive. They should be read in the light of all the rest of this book, and not taken as final authority at any point.

Pull apart with great care. Remove all threads and old paste and glue. Smooth out the backs by beating. Guard the outer and inner leaves of all signatures that are broken or weak with paper or jaconet.

Loose pictures, if they are to be kept, put in with guards. Frequently in rebinding the illustrations may be dropped with no loss either to the reader's pleasure or the cause of art.

See that the leaves are all in and complete.

No. 1. Books sewed regularly, that is, not whip-stitched. Guard the first and last signatures with jaconet. If the title-page or frontispiece is an insert, paste the guard along the insert and over the first signature. This saves the labor of guarding the insert and first signature separately.

Guard with jaconet the inner side of the inside leaf of every signature that is at all worn or weak; if badly worn guard also the outer side of the outside leaf. In some cases every leaf should be guarded. But remember that guards thicken the back.

Make two sets of four-page end-sheets by folding once with the grain pieces of lithographed lining paper; and two sets of waste papers by folding once pieces of good book-paper, about 60 lb. Guard the outside of the folds of all of these with jaconet, and place one of each kind at the front and back of the book, the lithograph one on the outside in each case.

Use Hayes's standard linen thread of a weight adapted to the book. The cotton thread used in book sewing machines wears well, but is not recommended for hand-work. No. 25 is good for books with light sections, 16 for those with heavy sections, and 20 for those with medium. Sew the book on four stout but flexible tapes, each about a quarter of an inch wide. Sew all along throughout.

Leave about three-fourths of an inch of tape projecting each side when cutting off.

From here on the process is very similar for this kind of binding sewed in the ordinary way, and for No. 2, whipstitched, which follows.

No. 2. Books which are whipstitched, being in such condition or of such character that they have to be trimmed at the back, being then simply piles of loose sheets.

Cut off as little of the backs as possible. Prepare and place end sheets and waste papers as above

described, except here paste the jaconet guard only along one side, the outer, of the folds of all of them. This gives firm hold for first overcast stitches.

Glue the back of the book slightly so that it may be divided into signatures of a few leaves each which will hold together.

Sew on same tapes as for a regularly sewed book.

In overcasting or whipstitching do not take up more than one-eighth of an inch for the deepest stitches. Make the signatures small and pass the needle through two of them with each stitch, taking the stitch diagonally.

Paste the lining papers to the waste sheets, all over, front and back. Paste ends of tapes on top of lining papers. Trim the book, cutting it as little as possible.

Glue the back slightly, and, when it is partly dried, round the book and then back it. In backing do not break the threads or pull them through the paper. This is especially to be guarded against on whipstitched books.

After rounding and backing, glue to the back and over onto the sides, passing beyond the jaconet guards, a strip of medium weight, soft, bleached muslin.

Measure and cut the boards, which should be of good quality, adapted to the wear the book is likely to have.

Cut the leather back, of pigskin. Do not pare it save slightly at the edges. Put a little paste on the boards to make them stay in place, and set them in place on the book.

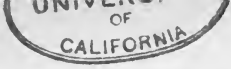

Put on the leather, leaving the boards in place, tucking the leather in at top and bottom,—head and tail.

When the leather is partly dried, the book having been kept under slight pressure, cover the boards with keratol or appropriate cloth. Make the corner fold by first turning the cover material in straight across the corner and then bringing in the folds from right and left.

Paste the end sheets firmly down on the inside of the covers. This fastens the book securely into its case. Press until thoroughly dry.

Letter in gold with large, rather heavy, black-face letters. Reduce the lettering to as few words as possible.

No rule can be given as to the glue to be used. Let your binder be sure that what he uses is good, whether the price he pays be high or low. He can tell whether it is good or not by testing it. Glue pots should be cleaned out frequently. Glue should be treated with judgment as to heat and degree of thickness at which it is used. It is animal matter that quickly changes its character and loses its strength under wrong conditions.

The boards to be used in a book should depend, as to quality and thickness, on the character of the volume they cover. Expensive boards on a book which will probably soon be too dirty to be kept, are not essential.

Neither strings nor tapes need to be laced into the boards on ordinary library work. They hold

well if carefully glued down on the inside, and very well if pasted between two boards or into a split in one.

Some books are best bound with tight backs, some with loose. There is no invariable rule in regard to this; it depends partly on the thickness of the

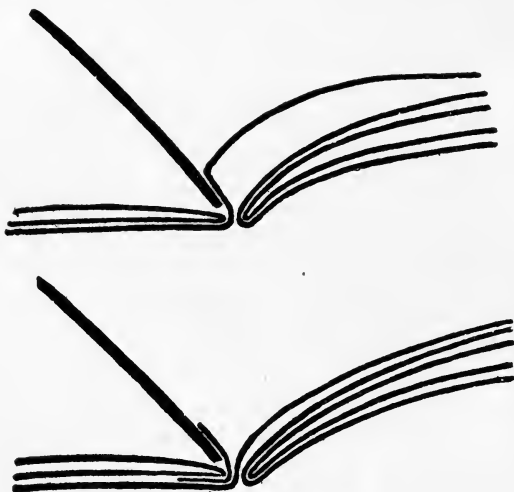

Plates

The first diagram shows in section a plate pasted on to a leaf of a book. This method is faulty, because it takes up some of the back margin of the leaf; if the leaf is pressed back the plate is apt to split off.

The second diagram shows the method of attaching a plate by means of a "guard."

From report of the Committee on Leather for Bookbinding.
Edited for Society of Arts. London: Bell & Sons, 1905.

book. Very thick volumes should have loose backs, usually.

It is usually wise to trim books when they are rebound. But this trimming should of course be as little as possible.

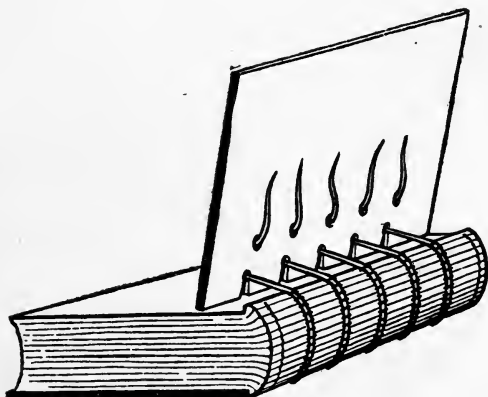

Showing the Method of Lacing in the Slips or Ends of Bands on a Flexible Bound Book

If depressions are cut in the board as shown, the slips can be left with an adequate margin of strength without clumsiness.

From report of the Committee on Leather for Bookbinding.
Edited for Society of Arts. London: Bell & Sons, 1905.

It is possible to whipstitch a book, even one which is printed on stiff paper, in such a way that it will be almost as flexible and open almost as easily as if it were sewed on tapes in the regular way. It is possible, but difficult. Few have done it. Few bind-

eries, if any, in this country have workers who can and will give to the work of whipstitching the care and thought necessary to produce a good job.

Some strengthen the top and bottom of the back, the head and tail, by a piece of cloth or tape passing



Showing the Advantage of a "French Joint" over an Ordinary Joint

No. 1. A section of an Ordinary Joint with the board open shows that the creasing of the leather is concentrated on one line.

No. 2. A section of a "French Joint" shows how this creasing is distributed over a great surface, and so enables sufficient flexibility to be obtained with much thicker leather than can be used with an ordinary joint.

From report of the Committee on Leather for Bookbinding.

Edited for Society of Arts. London: Bell & Sons, 1905.

over the back of the signatures and held to them by the sewing in a manner difficult to describe.

Music should be sewed regularly or all along and the inside and outside sheets of all signatures should be guarded with jaconet. This guarding of the inner

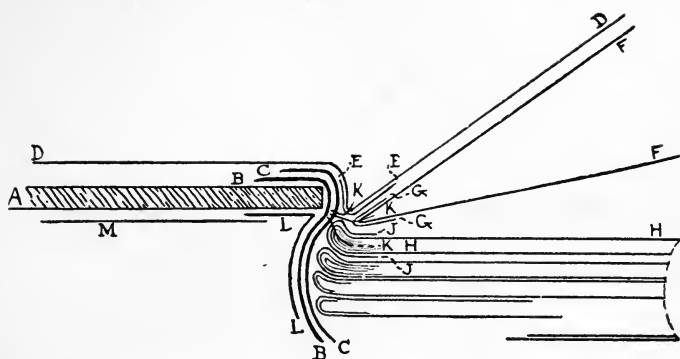

Anatomy of a Joint

- A Board of cover.
- B B Bleached muslin, pasted over back after rounding and backing.
- C C Strings or tapes on which the book is sewn.
- D D End sheets of lithograph paper. The part at the left is pasted to the inside of the board and becomes the lining paper. B and C being pasted over on to D, when D is pasted to A they are carried with it and lie under the end sheet or lining paper.
- E E Jaconet or thin muslin guard pasted on D before the book is sewn.
- F F Waste papers of good book paper.
- G G Jaconet guard of waste papers. Before the book is trimmed F and D are pasted together and become a doubled fly leaf.
- H H The first signature of the book.
- J J Jaconet guard of the first signature.
- K K K Paths of threads.
- L Leather back.
- M Cloth or paper side.

sheets makes the binding stronger, as the inner pages of a section always tend to work loose if much handled. The side and top squares should be about $\frac{1}{8}$ of an inch; but the bottom square about $\frac{3}{8}$ inch. This large square at the bottom raises the book on the instrument to allow the easy turning of leaves, as the pages frequently catch when the squares are the usual size all around. Newark finds half pig with Keratol sides very durable.

Large maps, drawings, etc., may be mounted on linen, jaconet, nainsook, ordinary bleached, or unbleached muslin. The material used should be five or six inches larger all around than the map to be mounted for convenience in stretching and working. Tack the cloth on a clean board, table or floor. Put the tacks very close together and tack the selvage edge first. The surface may be covered with waste paper before stretching the cloth on it. Apply a thin coat of thin paste all over. When dry, paste the map and allow it to stand about ten minutes to give it time to stretch. Lay the map on the muslin and rub it down under a stout piece of paper. Thorough rubbing down is absolutely necessary to make every part adhere. Proceed from the center outward, carefully rubbing out creases and bubbles. Dry thoroughly before taking up.

One person alone cannot mount a very large sheet.

Very small maps in books which have become somewhat worn and creased can be mounted on Japanese mending tissue. This paper is quite tough and thin, and wears well.

CHAPTER VI

Lettering and Numbering the Backs of Books

Several methods of lettering the backs of books are in use in libraries. The best is gilding. If this is well done with genuine gold it will remain bright for many years, and will stand hard wear better than any other style of marking. On leather this method should always be followed. Only the best work in gilding is worth the money it costs, and there is no substitute for gold that deserves mention.

Gilding on cloth by hand is rather difficult. It does not show well on light-colored cloth, or on some dark colors. On some cloths, also, gold titles become quite invisible in certain lights, probably because of a certain combination in them of color and texture. Dark green is often quite objectionable on this account, and the same is true of some shades of red, in cloths of a certain texture. This difficulty should be noted, and only those cloths used on books which are to have gold titles on which the letters show well, at whatever angle the light may strike them.

The process of gilding is described in books on binding. It costs usually about two cents a line.

Black ink is very good for lettering on some kinds of cloth, particularly on light-colored duck, canvas, buckram, whether cotton or linen, and art vellum.

The ink used should be "bookbinder's title ink," made for the purpose. The letters should be large and heavy-faced and not set very closely together. The method of applying the ink is to pour some of it on a piece of marble and then to apply to the type with a rubber pad. As the type is cold, considerable pressure is necessary to make the ink take well. Black lettering costs about the same as gilding, say, two cents per line.

Letters in gold are sometimes applied to books bound in cloth by printing them on a very thin piece of leather and then gluing the latter to the back. This method is also occasionally used on books in leather. These leather labels can be stamped by machinery in quantities, as is done for large editions by commercial binders, though this is not practicable for the ordinary library binder. They usually look very well when first applied; but it is not very easy to make them hold permanently.

The better method in almost all cases is to letter directly on the book, no matter what material it is bound in.

The binder should use brass type letters in most cases; they wear well and give a clear impression. Ordinary printer's type will do excellent work for a time. Brass type costs from 10 to 20 cents per letter, common type from one to five dollars per font, according to size and number of types. The best style for ordinary use is condensed gothic. A heavy-faced Roman, like Jensen, is sometimes good, and on larger books looks very well in capitals and

small letters. Use as large letters as the back of the book will permit. Reduce the number of words in all titles to the lowest possible number.

Samples of type well adapted to lettering in gold on the backs of books:

Sample 1—Gothic condensed, 18 point.

CARNEGIE PUBLIC LIBRARY
Free for the people

Sample 2—Schoeffer, 18 point.

CARNEGIE PUBLIC LIBRARY
Free for the people

Sample 3—Lining condensed title, 12 point.

CARNEGIE PUBLIC LIBRARY
Free for the people

Titles can be printed on paper also and the paper then pasted or glued on. This plan is not at all satisfactory for books which are to have much use, as the paper soon gets soiled and is very apt to peel off.

Many libraries have bound books in light-colored cloth, usually art vellum, and then lettered them by hand with india-ink. The result is not very satisfactory. The time taken in lettering them neatly is considerable; the letters soon get soiled and illegible, and even if very well done they look cheap and home-made. At the ordinary cost of gilding, about two cents per line, hand lettering is almost as expensive as gilding if the cost of the time spent on it is fairly

estimated. Then, to make them legible, the cloth chosen must be so light in color that it soon shows the results of handling and becomes dingy and disreputable. A dark cloth of the best quality and gold letters pay best.

On books bound in dark cloth or leather, numbers can be written in white ink. Some librarians find

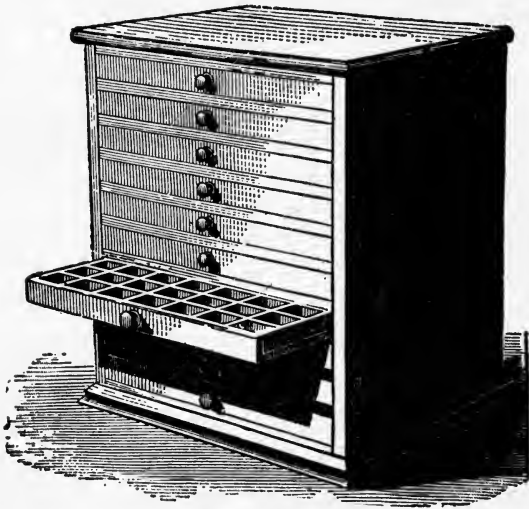

Type Cabinet

this plan quite satisfactory. The method is this: The place for the number being located, wash the varnish away from it with a clean cloth, dampened with a mixture of ammonia one part and water two parts, and allow to dry. Then write the letters with a fine camel's hair brush, about No. 2 in size. When thoroughly dry give the letters a thin coat

of shellac. David's white letterine is one of the best white inks. White ink is difficult to manage and wears off soon if not very carefully put on.

Labels should always be put at least four inches from the bottom of the back, the tail, that they may not be soiled or worn off in handling. They should be marked with india-ink in large, plain figures. On many books it will pay to have them gilded, as when thus put on they do not detract from the book's appearance and look well for an indefinite time. If labels are used, put them on as follows: The place for the label being located, wash away the varnish from that place a little with a clean cloth dampened with water and ammonia. If the book is thin cut the label before it is put on, so that it does not quite reach the edges of the back. If the book is so thin that there would not be sufficient room for the book number on a label cut to fit it, place the label on the upper left corner of the front cover. Press the label tightly and evenly down until it sticks firmly all over. This is most important. Use Dennison's round gummed labels. These, being round, present no corners to be easily ruffed up. They are free from lines around the border, so their whole surface is available for the book number. They can be had in several sizes.

Lay out a scheme for marking books, and then make model labels to be followed in marking fiction, classed books, reference books, juveniles, magazines, etc., so that the same kinds of combinations of letters and figures will always be written in the same way.

CHAPTER VII

Pamphlets

The subject of the care of pamphlets in a library does not come within the field of these notes; but it may be proper to say that experience and observation have led me to the conclusion that many pamphlets are bound and entered in the catalog which are not worth the labor they have entailed. How those should be kept that are thought worth keeping I do not attempt to say. Often those kept are not worth keeping, and still oftener those bound and catalogued are not worth binding. If they are bound, the style of binding they should receive, if they are in fact books in paper covers, is to be decided by the same rules as is the same question in regard to other books. If they are in fact pamphlets—a few pages with no cover, and must stand on the shelf and will be little used, a cheap binding may be made thus: Take off the cover; fold once a sheet of stout paper to the pamphlet's size; cut two boards for covers, a little narrower than the pamphlet; paste them to the paper mentioned about half an inch apart; paste a strip of book cloth down the back and over the edges of the boards; paste the cover to the boards, front and back; sew the pamphlet into the case thus roughly made with

stout thread through three or five holes along the back (this last process is called stabbing); trim. This is simple, strong and inexpensive.

If the pamphlet consists of one signature only the method just described can be followed; but the sewing should be through the back, a saddlestitch, with the knot inside. The binder's knot or stitch is thus made: Having three holes for the thread, go first down through the center one, back through one of the end holes, down again through the other end hole, up through the center, and tie the two ends over the thread which passes from end hole to end hole. With five holes the process is similar and easily followed.

A very neat pamphlet binding, for pamphlets too large to be saddle-stitched, is the following:

Cut two pieces of smooth, hard, "flat" paper the size of the pamphlet; along one edge of each paste a strip of thin cotton cloth, bleached muslin, about half an inch wide; lay one piece each side of the pamphlet, cloth strips at the back, and sew the pamphlet through these strips, close to the back, with three holes or five as seems advisable. Make two end-sheets of two leaves each, the size of the pamphlet; guard each with muslin; paste these to the first sheets, all over, one on each side of the pamphlet; cut boards and paste them down on the outer halves of the end-sheets (each end-sheet has now become, one-half the lining paper for the cover, the other half, half of a double fly leaf); put on a back of art vellum, leather or other material; paste on the pamphlet's cover;

trim. This binding is very strong, very neat, opens quite easily and will wear well. The boards can be covered all over with cloth, and the binding will then wear much longer.

Ballard's clips find favor with many librarians, for both pamphlets and magazines. They hold things together neatly and securely, and hold magazines into covers of cloth or leather quite effectively. They are strips of sheet steel, of several widths, bent into about three-fourths of a circle. Small steel levers fit into cleverly adjusted holes and make opening easy.

CHAPTER VIII

Magazine Binders

It has long been one of the library traditions that magazines used in the reading room should be put into stiff and heavy temporary binders as soon as received, and so arranged, usually on racks holding them vertically, that they can all be seen at once. It is now permitted to doubt the wisdom of this proceeding. The binders are expensive; the best of them soon get a worn and dingy look, even if they hold together for a long time; the racks with their contents are usually not ornamental and are often quite the reverse. The space taken by the racks can ill be spared, especially when the area needed by browsers in front of them is included. If the number of periodicals taken is quite large the display space needed for them is quite out of proportion to the use made of them. Recent back numbers of most journals, as well as the last numbers, should be made accessible to readers, and for this there is no provision in the vertical file arrangement. There seems no better reason for exposing to the casual reader of the reading room the full fronts of all the journals the library takes than there is for making a similar display of all the books the library buys.

To the display of all journals on terrace tables

most of the objections just noted are also applicable. A careful consideration of the relative value of current numbers of periodicals in a library and of space, time and energy that should be put on their presentation to the public, will lead one to the conclusion that the best way to handle them is to lay them in alphabetical order on plainly labeled ordinary book shelves wide enough to hold the larger ones, set about six inches apart, that the numbers for the past six months may be kept together.

The thin journals which are most read, like "Puck" or the "Scientific American," may well be slipped for a week into an inexpensive binder like the one called "Cleveland" in the list which follows. Magazines much read, like the "Century" and "McClures," can be so reinforced in a few minutes, as described below, that they will keep quite neat for several months.

This method is economical of space; keeps the journals easily in one alphabetical series; makes six numbers accessible instead of one; eliminates the question of binders; saves the assistant's time, relatively to the service given to the public; and asks the public simply to remember their alphabet and to read the shelves.

Binders that require the punching of holes through the backs of magazines should be looked on with suspicion; though in spite of its expense the binder of this type, with flexible metal strips in place of strings and with polished sides containing actual covers of the magazine within, has had much use.

It wears well, is put on about as quickly as any, exposes the date and name along the magazine's back, and looks more attractive than any other binder when perched in rows in vertical racks.

All other binders may be divided into three kinds: The Clip, the Bar and the String.

The Clip is based on the Ballard clip idea. The Johnston is a good example. A spring in the back grips the sides of the magazine and holds the binder on. It tends to make a magazine less easy to hold open. It pleases a good many.

The Bar has for its main feature one or more strips of steel, which run down the back of the magazine and are fastened to the binder by a hinge at one end and a hook at the other. Of all of this kind the best for the money is, perhaps, the New Haven.

The String uses a string or elastic band to hold the magazine. In the one called the Springfield, first used in Los Angeles in 1890, the string passes through the magazine, between sections, and through three holes in the back of the binder in a binder's stitch.

The Newark Library has tried many kinds of material for binders. Thin book cloth soon wears out. Heavy and strong cloth soon gets soiled. Full leather is very expensive, unless the leather used is light and poor, and then it soon wears out. Good leather backs outwear sides of any cloth. A Cleveland binder made for "Harper's Weekly," with heavy cowskin back and keratol sides, was in constant use for 30 months and looked well nearly all

that time. It costs 70 cents. The few binders now used in the Newark reading room are made in this style.

Covers of strong paper pasted to the outsides of single copies of magazines to protect them during reading-room use or for lending, the Newark Library has not found satisfactory. We reinforce the covers of single magazines for this purpose as follows and find the method quite satisfactory:

If the original cover is loose, take it off and paste on again carefully. Line the cover with thin, white bond paper, pasted on all over and lapping a half-inch onto the magazine itself. Press for ten minutes in a copying press. Paste a strip of thin dark-colored book cloth down the back on the outside. Put under moderate pressure until dry. Write the name and date of the magazine on the strip of cloth with white ink.

Sew large magazines like the "Ladies' Home Journal" into covers of stout paper. A strip of paper an inch and a half wide placed in the center of the section through which the magazine is sewed keeps the sewing from tearing the paper.

Single copies of magazines can be bound for lending, at about 15 cents each, in this manner: Take off covers; trim; remove table of contents if it faces the cover; paste strip of strong cotton cloth down the back, and extending about an inch over the sides; staple this on with at least three staples in the same line with the staples which hold the magazine together, or sew with stout thread through five

holes; cut covers as for an ordinary binding; paste them to the strip; cover all over with art vellum; line covers with paper (this lining can be put on all over as the first step in the process, and pasted to the covers after they are on, thus forming the end paper); paste the front cover of the magazine on the front in such a way that the date line down the back comes on the back of the new cover. This is neat, convenient and quite durable.

A few of the more popular binders are listed below. The material used to cover them can be endlessly varied.

1. The New Haven Binder, designed by Mr. W. K. Stetson, Librarian of the Public Library of New Haven. A solid back of metal. A metal rod hinged at one end passes through the middle section of the magazine. The free end of the rod is formed into a hook which, being slipped under a metal loop attached to the back of the binder, holds the magazine firmly in place. Costs from 85 cents to \$1.15. A simpler binder, also designed by Mr. Stetson and made on the same principles, sells at 55 cents.

2. The Johnston Binder, made by William G. Johnston & Co., Pittsburgh, Pa., has a round steel spring back which grips the magazine. Costs from 75 cents up, according to size.

3. The Boston Binder, made by the Office, Bank and Library Co., 157 Summer St., Boston. A rounded wooden back supports the binding device which consists of two bars of steel pivoted at one end and

fastened at the other with a pin. Costs from 75 cents to \$2.00 according to size and material used.

4. The Torsion Binder, made by the Barrett Bindery Co., 180-182 Monroe St., Chicago. Two flat steel wires are hinged to the binder at the top and fitted with knobs at the free ends. These pass inside the magazine and a slight pressure on the knobs sends the free ends of the wires into an inclined slot. Costs from 95 cents to \$4.50 according to size and material used.

5. The Springfield Binder has a strip down the back of a simple cover or case, with three holes punched therein through which the magazine is laced in by strings. Shoe strings or tape may be used. Costs from 25 cents up.

6. The Chivers Binder, made by Cedric Chivers, Bath, England, and Brooklyn, N. Y., is like the Springfield cover, but with a separate flat brass rod around which the magazine is sewed into the cover.

7. The Weis Binder, made by the Weis Co., Toledo, Ohio, has metal grooves in the back which hold the magazine.

8. The Buchan Binder, made by Buchan Mfg. Co., Newark, N. J., has a steel back which consists of a hinge regulated by a screw. One or more magazines may be kept in the binder. Good for magazines that are poorly put together.

9. The Roedde Magazine Binder, made by the Flexible Back Looseleaf Ledger Co., Buffalo, N. Y., varies somewhat from the Torsion and Boston

Binders, but is built on the same principle. Costs from \$1.10 to \$8.00.

10. Cleveland Binder, so called because much used in the Cleveland Library. A simple cover or case in the back of which are holes half an inch from the top and bottom; through these a piece of narrow elastic is sewed. The magazine, opened at the middle of a section, is slipped under the elastic. Recommended for weekly journals.

11. Klip Binder, made by H. H. Ballard, Pittsfield, Mass. A simple cover attached to the magazine by a pair of steel clips, put on with keys. Price of klips, 50 cents per box of 10.

12. The Philadelphia Binder, made by G. D. Emerson, Philadelphia, Pa. A rod passes through the magazine and springs into hooks at each end of the back.

CHAPTER IX

Repairing Books, General Rules

The universal rule in this matter is, don't. To this there are exceptions; but many if not most of the books which are repaired are so injured by the process itself, or by the wear they receive after they are repaired, that it would have been better for them if they had not been repaired at all, but sent direct to the binder.

Librarians do not pay sufficient attention to book surgery.

All repairing of books should be done by skilled persons. The question of whether or not repairs shall be made at all should be decided by a person who has not only technical skill in repairing; but also knowledge of the use to which the book in hand is likely to be subjected. This, because in many cases it will be evident to a person who knows about the use the books are to have that certain of them should not be repaired at all, no matter if in quite a dilapidated condition, with loose covers and loose leaves; but should be neatly wrapped in good manila paper, labeled plainly on the back and set again on the shelf. The few times in a year when little-used books are wanted do not, in many cases, warrant their rebinding. Repairs on them, no matter how

well done, are likely to injure them. Books which are rarely borrowed, even though they are used occasionally, or are even a good deal handled because they stand near books which are much used, should perhaps be mended a little; loose leaves should be tipped in, at least. But work on them beyond that is often injurious.

The feeling that all books in a library should be neatly bound has caused much unnecessary expense.

In most libraries of moderate size and in all large ones, there should be a supervisor of binding and repairs; a person thoroughly familiar with the whole routine of library work, familiar also with literature, keeping close watch of the rise and fall in popularity of new books. Such a person could say, for example, that the library's third copy of the *Valley of Decision* and the fourth copy of the *Crisis*, if ready for repairing or rebinding, could with good economy be placed on a reserve shelf, not accessible to the public, there to be held until the delivery desk assistants find a call for them. That is, she would know that with two or three copies in good condition of these books in circulation there would almost always be one in the library. When the library's stock of such books as those named becomes reduced to one sound copy she can then tell, from the demand for it, if it is wise to bind one copy, or all; or if it is wise to do more than mend.

This omniscient person who has charge of binding and repairs, reports to the head of the library that such and such books are past repairs; that they will

cost 35 to 50 cents apiece to be properly rebound, and asks, "Will the library ever want them again?" If not, then she will advise that they be given away and their cards removed from the catalog. Or, if they must be kept for historical or religious or superstitious or other reasons she will advise that they be neatly tied up in paper, labeled, and put back on the shelf.

Knowledge of the art of mending implies not only knowledge of the process of making a book by machinery and by hand; but also knowledge of the different kinds of paper, how they wear, if they break easily, if they will soon grow brittle, and the effect on them of attempts to hold them with paste or glue.

Along with this knowledge should also go knowledge of the cost of each individual book, and such knowledge of their use as will enable the repairer to decide at once whether 10, 20, or 30 cents spent in repairs will or will not pay.

As long as there are so few assistants who are at all familiar with paper, type, binding, literary quality, popularity, cost, etc., it is well to discourage almost all book repairs.

As soon as we admit, as we must, that a good book, costing from one to two dollars, must be mended carefully if at all, we have opened the door for a large expense. An assistant can easily spend an hour or two on a book, repairing its cover, mending a few leaves and putting it in order. When she gets through she will have put from 30 to 50 cents'

worth of time into it, has probably permanently injured it, and in a few months or years it will be in worse condition than if she had never touched it at all. Moreover, the same amount of money put out in cash instead of time would in many cases have rebounded it.

In a measure the remarks just made apply even to popular books, much used by children or adults. It is easy to spend more money in mending them than good economy can justify. Mend sparingly; rebind early.

The reason for this warning against mending lies in the anatomy of the book and the injury it receives from handling after it begins to break up, and especially after its first breaks have been mended by a prentice hand.

The weakest point in a book is the joint. In publishers' binding of today this joint is made by a piece of super, which is glued to the back of the book and then to the inside of the cover, plus the end paper which is pasted over it and also onto the cover. This super is weak. If it is put on with a poor glue that glue soon grows hard and the joint is further weakened thereby. It breaks or tears easily. Also, it parts easily from the back to which it is glued and from the cover. No strings or tapes pass from the book to cover. When the joint once comes loose from either back or cover, or breaks, it cannot well be either attached or mended again. It is sometimes possible to take a broken book out of its case entirely, remove the old and attach new

super, add new end sheets, put it again into the case and get considerable use from it. But any other kind of mending of the joint is almost futile and even this is injurious. And the better such mending seems at first to succeed, the greater the harm it is really doing to the whole book. For the mending usually consists in pasting a strip of strong paper or cloth along the joint. This simply conveys the strain from the joint proper, where it belongs, to the first leaf of the first signature. This is only paper, usually poor at that. It soon breaks and lets its other half loose. Very commonly other injuries are worked at the same time. The book gets loose again, if it was ever really tightened. The super with hard glue attached rubs about on the backs of the signatures; several of them are cut through, and the possibility of a rebinding with proper sewing is either gone forever or can be regained only after the long labor of mending many signatures.

When the cords or bands are broken in a book in which they are used it is as useless to attempt to fasten book and cover together as it is when the super gives way in publishers' binding.

Loose leaves appear earliest in books printed on paper which is so heavy that it breaks almost as soon as it is folded. If the loose leaves of such books are tipped in they tend to tear out with them the ones they are tipped onto. Leaves should rarely be tipped into books which have never been rebound. In rebound books which are in their last days and

will never be rebound again it is sometimes proper to tip in.

Full-page illustrations which come loose can in most cases be left out to advantage. To tip them in again hurts the leaves they are fastened to. They are usually so poor that it is a kindness to the reader to throw them away.

In the long run a book needing more than very slight repairs will give better return if so rebound at once that it will hang together until so dirty that it will have to be thrown away.

Some books, especially some of those printed on cheap, heavy, coated paper, will never pay to rebind. They should be mended, each according to its constitution, and when beyond mending thrown away.

Good general rules for mending books are few. The first and most important of all is: Be sparing with paste or other stickist. Another is: If a machine-bound book is broken at the joint, the cover beginning to part from the back, send it straight to the binder.

The best plan is to buy your books as far as possible properly bound for library use direct from the publishers' sheets. Such books never need mending or rebinding. Being flexible and easily opened their leaves are rarely torn; and, for the same reason, getting no hard pressure from moist or dirty hands in trying to keep them open, their leaves keep clean for a long time.

Books not thus bound in the first place should be rebound in first-class manner when they begin to break. Parsimony in rebinding is a library thief.

CHAPTER X

Repairing Books, Newark Methods

Books are sent to the bindery and repair department from the delivery department, as the head of the latter department may direct; and the head of the bindery department, or some one under her direction, is constantly looking over the shelves for books that need attention.

In the repair department, which attends to the repair of books and to the sending of those needing binding to the bindery, these directions are followed:

When a book looks dilapidated, note carefully its condition throughout. Consider these questions in regard to it: Is it worth repairing? Should it be covered? Should it be rebound? Should it be discarded? No general rules can be given by which to answer these queries. Each case must be decided by itself.

General cleaning. Look through book; turn out corners of leaves which have been turned in; mend torn leaves with transparent mending paper, or Japanese mending tissue; erase dirt and pencil marks.

Pencil marks. For removing soil and pencil marks, we have tried the Ruby, Cerise, and Ideal erasers, Art gum, and ivory soap and water. We like the Cerise, manufactured by Eberhard Faber, as having

more grit than the Ruby and yet not injurious to the paper.

Torn leaves. Ordinary circulating books are best mended with narrow strips of Japanese tissue and paste. This is cheaper than commercial gummed paper and is preferable to it also, as the mucilage on the latter grows dark and brittle in a short time. Dennison's adhesive tape costs about three cents for a roll of four yards, while one sheet of Japanese tissue, costing two and a quarter cents, cuts into 46 yards of strips the width of Dennison's.

Torn leaves in choice books may thus be mended: Match the edges of the tear carefully and apply a narrow line of paste along them. Lay over this a piece of Japanese tissue larger than the tear, and rub it down very lightly. Repeat this on the other side of the leaf and put under moderate pressure. When dry, pull off all the tissue that will come away easily.

Cleaning publishers' bindings. Often there are a few spots on books which make them unsightly. It is not advisable to wash a cloth cover, unless very dirty, as the finish is thereby removed, thus permitting the book to become soiled again almost with first handling. In case, however, a publisher's cloth binding has become so soiled as to need washing, it can be very well cleaned and given a new finish by the process described below. If the directions are carefully followed books treated in this way will look almost new and will keep clean almost as well as they did when they came from the publishers' hands:

Hold the book by the leaves in the left hand, with the covers outside of fingers and thumb; rub the cover gently with a sponge dipped in a mixture of vinegar and water, half of each. Continue to rub it carefully until it is quite clean; but do not press hard enough or rub persistently enough to take off any of the color. Rub gently, slowly and carefully, letting the vinegar and water do most of the work. When thoroughly clean, or as clean as the character of color and cloth will permit the book in hand to be made, stand it on end to dry. The drying will take at least a half hour; a good plan, consequently, is to clean as many books at one time as one can do in about forty-five minutes. The first one cleaned will then be ready for the next step when the whole lot has been finished.

In a common drinking glass, place one teaspoonful of egg albumen, to be had at any book bindery, and two teaspoonfuls of vinegar, add half a glass of water and let this stand over night. The next day, add two teaspoonfuls of binders' paste, stir thoroughly, and it is ready for use. With a sponge give the cleaned books one coat of this mixture and again stand on end to dry. This mixture will not make the covers as shiny as does shellac or varnish, but will cover the surface well and protect it. It will be sticky when first put on.

Leather decay. Leather bindings which show signs of decay may be treated to an application of vaseline or olive oil, or a solution of paraffin wax in twice its weight of castor oil, slightly warmed.

Rub in well with fingers or cloth. The progress of decay can in some cases be stopped by this means.

Labels. Take off and replace with fresh ones all torn and badly soiled back labels. To do this, apply to them a mixture of two parts water and one part ammonia. After they are soaked enough to come off very easily, take them off with a dull knife. In most cases let the water remain on the label for several minutes. To scratch off the label without soaking it first will often injure the book. Labels that have been varnished are sometimes very difficult to remove and great care should be exercised with them.

Replacing labels. Follow method used in putting them on when book is new, except that it is not necessary to moisten with ammonia and water the place on which the label is to go. Use Dennison's round gummed label, of a size small enough to rest entirely on the back of the book. Never let a label extend over and around the edge of the back. For quite small books trim the label. Moisten the gum slightly and press and work it down carefully until it has set all over. This is very essential. Mark the book with indelible ink. Cover label with quite thin white shellac. The shellac should extend a little onto the book beyond the label all around. Let the first coat dry thoroughly and then apply a second.

Labels on the sides of books. If the cover is durabline or keratol, first put a coat of shellac on the place where the label is to be placed. Allow this to

dry. Paste and put on the label, rubbing it down thoroughly. Allow it to dry and give it a coat of shellac. If the cover is cloth, use ammonia and water instead of shellac before putting on the label.

Loose leaves. If the loose leaves are illustrations in an ordinary novel, take them out and send them to the picture department. Replace other pictures with a guard of Japanese mending tissue. This tissue takes up less space than bond paper and must always be cut with the grain of the paper or it cannot well be handled. Rub the tissue down, first laying over it a piece of paper.

Single leaves can be inserted in three different ways:

1. Fold half-inch strips of bond paper in the center lengthwise along the grain. With a small brush apply paste to the outside of this strip. Attach half of it to the edge of the loose leaf and the other half to the adjoining leaf, close in by the fold. Cover the strip with paste evenly, but sparingly and quickly, stretching it as little as possible. If it does stretch, and it tends to do so as soon as moistened, it will when dry wrinkle the page to which it is attached. Loose leaves should be attached in this way only in books which are in good condition.

2. Draw a soft piece of twine over a board which has received a thin coat of paste; then pull this cord through the back of the book where the loose leaf is to be inserted. This leaves in the book just enough paste to hold in the loose leaf. Work the loose leaf carefully back into its place, close the back and let it dry. This method is not advised for general use.

3. On the back edge of the loose leaf put a little paste. Lay the leaf in place and close the book for a second, then open and push leaf in place with folder. This method is used with whipstitched books.

The first two methods are generally used with books sewed in the ordinary way on tapes or cords.

Sewing in loose sections and loose leaves.

1. Loose back books. Thread a darning needle three inches long with Barbour's linen thread, No. 40, or Hayes's linen thread, No. 20. Open the book in the middle of the loose section. Near the top and bottom of the fold will be seen holes made by the binder. Pass the needle through a hole near the top, and out between the book and its loose back. Do not pull the thread clear through. Drop the needle and thread between the back of the book and the loose part of the binding to the bottom, then run it from the outside into the middle of the loose section through the hole at the bottom thereof, and tie at the point of beginning. Insert Japanese guard over thread. This holds the section in fairly well. Always guard a section before replacing by pasting a half-inch strip of bond paper, folded in the middle, along the folds.

2. Tight-back books. Cut a guard of jaconet or bond paper three-fourths of an inch wide and as long as the book. Sew the signature to the middle of this guard and then paste the guard in the book, attaching half of it to each of the leaves adjoining the loose section.

Broken bindings. Books in publisher's cloth, which are breaking out of their bindings, are mended in some libraries with considerable success as follows:

The case is taken off with care. If possible, the lining of the boards is removed in such a way as to permit of its being put on again. The super is removed from the margins of the boards and from the back. Necessary repairs are made to end leaves and stitches are taken in the book when out of the case, if need be. The back of the book and the end leaves are then covered with a thin coat of flexible glue. The book is then again put together. This glues the back of the case directly to the back of the book, making it a tight back. It is reported that books thus repaired wear very well. Newark has not had success with this kind of work.

Fly leaves and end papers. To add a new fly leaf. Cut suitable paper just the length of the leaves of the book but half an inch wider, fold over the half inch and paste it; attach this half inch to the last fly leaf in the book, close to the joint.

If a book has two or more fly leaves, very often you can save much time and still have your work look well by turning the first leaf back and pasting down the page facing.

If leaves stick out of book after they have been tipped, guarded or sewed in, trim them off even with the others.

If the end sheet or lining paper of the cover is soiled or injured, cut a sheet of suitable paper to

fit the lining paper exactly and paste the new sheet down all over, fully covering it.

After the new lining paper is put in, keep the book for a time under moderate pressure or the cover will curl.

Loose joints. If books are loose along the joint they can sometimes be repaired by pasting along the joint inside as a guard a strip of thin muslin or bond paper, an inch and a quarter wide. Fold the strip through the center, paste it and apply it to fly leaf and book cover. A better material than muslin for this purpose is jaconet, being light in weight and starched a little. The book should lie open and flat after mending until it is dry.

This, as has already been noted, is a poor method of mending a broken joint. By it the strain is passed from the cover through the new joint to the fly leaf, and the strength of the new joint is only the strength of the fly leaf itself, which is generally a poor piece of paper. A better way, in some cases, is to take the book entirely out of its cover, pull the super from the back, sew on new end sheets and glue a new piece of super or muslin over the back and extending half an inch onto the sides. Let this dry thoroughly. Then cover with paste the back and the end leaves, the latter being the sheets which are now to become lining papers, and put the book again into its case. This is recasing, in effect, in the manner in which the book was first put together.

Loosened back. A book which is in fairly good condition, with sewing protected, but loose in the

case, can sometimes be strengthened by applying paste or glue down the inside of the loose back of the cover. This can be done fairly well with a long handled brush. This changes the binding from a loose to a tight back.

To reattach loose covers. The method here described should be applied only to books which are little used. Cut a strip of muslin the length of the book, and about an inch and a half wider than its back. Apply hot binder's glue to it and put it over the back on the outside. When this is dry, cover the book with brown wrapping paper as described under the heading "Covering books," as a book thus mended is quite unsightly.

When a book is out of the cover, but has its sewing intact and the super or paper over the sewing firmly in place, it may be wise to give the back a coat of hot glue and put book again into its cover, thus making it a tight back.

Covering books. Cut brown Rugby wrapping paper into sheets of such a size that they will extend from 2 to 2½ inches all around beyond the book when laid open on them. This size will be found to be nearly 13x17 inches for the ordinary 12mo. Lay the closed book on the paper with back in the center and toward you, making sure that the proper margin of paper is left all around. Fold the paper over the front edge of top cover; reverse book, this time with front edge toward you, and fold and stretch paper tight over the front edge of the cover. Take book by the back in the left hand. With scissors cut the

paper at top and bottom, with slight inward slant from its outer edges down to the four ends of the joints. Take out the book, and turn in these center flaps with a double fold, putting a little paste on them after first turn. Replace the book in the cover, flush with head and tail. Tuck in folds at the corners of the front and back lap, making not too great an angle; crease well. The top and bottom laps should lie over the front and back laps. Put a touch of paste on laps at corners, but do not put any on the book itself.

Residing books. Books in good condition as to their bindings, being still solid, but having badly worn or badly soiled sides, send to bindery to have the covering of the boards, not the leather of the back, taken off and replaced with fresh keratol. This costs about 10 cents per volume. This can also be done in the repair department, and book cloth can be used instead of keratol.

Soiled edges. The edges of soiled books can be somewhat improved by rubbing them with sand paper.

To cut fore edges of bound book. This is never done to a book of value or to one that can be rebound; but cheap, shabby books with sound leather backs which hold together well can be freshened by cutting the fore edges and, if necessary, residing. Sometimes one can cut straight down through the front edges and the two boards, reside and insert new end pages. This seems a barbarous process; still, it freshens the appearance of the book very much and often prolongs its usefulness.

Maps. When small folded maps are badly torn line them throughout with Japanese tissue, jaconet or nainsook.

To freshen black leather. Sponge off with ordinary black ink; dry; rub over with paste; dry; apply a coat of bookbinders' varnish; dry; rub with vaseline.

Broken boards. Books which have one or both of their sides broken, but are otherwise perfect, can have their boards replaced. Do not do this to books in publisher's binding, as such books will soon have to be rebound in any case.

On a book which is hand sewn, with leather back, a broken board can be replaced thus: Pull off the cloth side, lift up the leather carefully where it laps over the side, also the muslin on the inside and pull out the broken board. Put hot glue along both edges of new board to be inserted, and put in place. Rub down well, and put under pressure, then reside and insert new end leaf.

Ink stains. These if on the leaves can generally be removed with ink eradicator or javelle water; but if they are on the edges and have soaked down into the book, nothing can be done but to cut the edges and have the book rebound. If the stains on the edges have not soaked in very deep, sandpaper can be used on them with good results.

Ink stains can be removed from Keratol by applying to them household ammonia of full strength with a small bristle brush, working it over a little to loosen the ink. Allow this to stand a minute

or two and then rub with soft cloth and wash well with water. This cannot be done with imperial cloth, as ink sinks into its fiber.

General stains. Many brown stains can be removed with a strong solution of washing soda, or better with javelle water. Wash with clear water and dry thoroughly after removing the stain or a dark line will later appear at the edge of the spot which was wet; put in a press with clean papers between the leaves. Alum and water also give fairly good results. Water and a little ivory soap will remove some finger marks. All of these methods have the disadvantage of removing the size or finish in the paper so that it soils quickly again.

Grease marks. For spots made with grease use benzine; while still moist apply a hot iron, with a blotting paper on each side of leaf.

Paste. Paste must not be used if not in a good condition. The thickness at which it should be used varies with different kinds of work. Thin paste is quickly taken up and under its application paper quickly expands. In most cases this stretching or expanding of the paper is a disadvantage. If it is desirable that the paper be so applied as not to draw or curl that to which it is applied, it should be covered quickly with thick paste, then applied at once and not much rubbed after it is in place.

The dishes in which paste is kept should be thoroughly and often cleaned; brushes the same. Bits of cloth used in pasting should either be thrown away or washed after they have been used a short time.

CHAPTER XI

Repairing Books: Materials and Tools

In spite of the remarks heretofore made about the injury often done to books by repairing them, even when the repairs are cleverly made, it is well for any library, however small, to have a mending table at which such work on books as seems necessary can be done. The materials for this work can in part be obtained from a bindery. There one can get super, pieces of book cloth of several colors, and some of other things mentioned below and in the list of technical terms. One needs for book repairs some or all of the following things, according to the amount of work to be done.

Brushes. Buy a small brush, about as large as a lead pencil, and another half an inch in diameter. Their prices vary with their quality, from 6 cents up. These will be sufficient for most purposes. Get good ones; and for paste and glue the kind set in cement, not in glue. Artists' bristle brushes are good.

Cloth. A yard or two of super. This is stiffened a little and pastes and handles more easily than ordinary muslin. If you are going to put backs on books you will need also pieces of bookbinder's cloth. These can be bought at almost any bindery in yard lengths. Get also pieces of cambric and fine muslin

called nainsook, or jaconet, for guarding signatures and similar work. It costs 15 cents a yard.

Copying press. For pressing books. One 10x12 inches will cost about \$3.75.

Cutting board. The best cutting board is one of hard wood. A common bread-board will serve for small work and costs only a few cents.

Folder. Flat piece of bone. 15 cents.

Glue pot. Get the regular double pot of iron. A No. 2 will cost about 75 cents.

Ground glue. Best, 18 cents a pound.

Gummed paper. Paper and cloth ready gummed and other useful repair material can be bought of Gaylord Bros., Emerson Building, Syracuse, N. Y., and also of Holden Patent Book Cover Co., Springfield, Mass.

Japanese mending paper. Handmade Japanese Window or Shoji Paper used for mending and guarding can be obtained from Japan Paper Co., 34 Union Sq., N. Y. Price \$5.00 per ream of 500 sheets 16x22. This is the best of all mending papers for repairing torn leaves.

Knife. A good knife is what is called a shoemaker's knife, a long blade, square at the end. 15 cents. Keep the corner square by occasionally knocking a piece off the end. For a sharpener wrap a piece of fine emery paper about a square stick and tack it down.

Mending tissue. See Japanese mending paper.

Needles. Several sizes, especially the regular sewing needles of the binder.

Paper. Different kinds of book paper, to be obtained from any printer, will be needed for replacing end sheets, also thin bond paper for guarding leaves. Rope manila of the best quality will also be found useful. Get also some of the rolls of adhesive paper sold by The Dennison Manufacturing Company, 11 Dey St., New York ($\frac{3}{4}$ inches wide, per dozen spools 40 cents), for mending torn pages. It is very convenient.

Paste. Buy this at a bindery, if you use much. For occasional use it can be thus made: stir flour in cold water until smooth, add hot water, let it boil for a few minutes, and add a little salt and alum as preservatives. Good paste can be bought in jars. Higgins's is the best. The cost is 25 cents per 8-ounce jar. Almost any stationer carries it, or it can be ordered of Charles M. Higgins, 168 Eighth St., Brooklyn. A convenient thing for paste in small quantities is the tube. The several makes are all about equally good.

Paste made of starch is best for work on fine books, as it is more transparent and shows less than other paste.

Ruler. One with a brass edge is handy, but not essential.

Scissors. Slender, 6-inch blades, good quality, 75 cents.

Sewing bench. This can be made as follows: Take a board 24 in. long and 10 in. wide. On the side of it and 14 in. apart nail two uprights, $\frac{3}{4}$ in. square and a foot long. Across the top of these

nail a stick $\frac{3}{4}$ in. square. Tacks can be driven into the board and into the cross stick above where needed, and cords or tapes stretched between them. This gives you all the essentials of a sewing bench.

Thread. Some of Hayes's best Irish linen thread, smaller size, say No. 18. Or Barbour's linen, No. 30.

CHAPTER XII

Covering Books

Few libraries now cover their books. The reasons for covering them usually given are, that the paper covers gather dust less easily than do the publisher's cloth bindings; and that the paper covers can be renewed when soiled and books can thus be kept at small expense fairly clean as to their exteriors.

The objections to the paper cover may thus be stated: It takes away the individuality of the book and thus detracts from its interest; the cover has a tendency, unless very carefully put on, to strain the back of the book; borrowers are more careless in handling a covered than an uncovered book.

The only use the Newark Library has found for book covers is on old volumes which are very rarely used and yet are too broken or too much worn and disfigured to look well on the shelf. Frequently old leather bindings crack along the joint so that the sides separate from the back. When this occurs a piece of muslin covered with hot glue applied to the back of the book, extending onto the sides, will hold it together fairly well, and then a paper cover hides the defacement.

The process of putting on a paper cover is described in the chapter on Repairing.

The Newark Library has experimented with several materials and at this date has found that Rugby wrapping paper has given better satisfaction than any other. It is a tough brown paper, which can be obtained from Lindenmeyr & Sons, New York. Cost, \$3.30 per ream; size, 24x36, 60 lbs.

The arguments for covering books used in schools are somewhat different from those that may be applied in regard to the same practice for books in libraries. The Holden Patent Book Cover Company, of Springfield, Mass., makes an adjustable cover of very stout, water-proof paper. This cover and others akin to it are used to a great extent in the public schools.

The same Holden Company publishes a little pamphlet called, "How to Care for Books and Keep Them in Perfect Repair." This they present to teachers who make use of their appliances for repairing books. These appliances include thin transparent paper glued on both sides; the same glued on one side; polished cloth in several colors glued on one side; paper in long strips, so folded and glued that they can be conveniently used to strengthen and repair bindings; self-binders, which are strips of glued cloth with little tongues cut out and projecting from them, that may be used to hold cover and book together.

It appears that in schools which purchase materials like those made by the Holden Company, and instruct their teachers to use them on books as soon as any of them show the need of repairs, the annual cost of text-books is reduced. Probably the cost

would be still more reduced were the books mended very little by a skilled person, and were they properly rebound as soon as they need to be.

Gaylord Brothers, of Syracuse, N. Y., make and sell repair material similar to that of the Holden Company.

Further light is thrown on this subject by certain answers to questions recently received from forty superintendents in the United States. These answers show that in two only of forty cities where text-books are furnished is any systematic attention given to the care of text-books. In two cities there is an official curator of books who looks after the covering, repairing, and rebinding of them.

The custom in public schools seems to be to purchase text-books, to keep them in use with a minimum of repairs until they are too tattered and soiled to be thought respectable even by the most careless teacher, and then throw them away. This practice is probably wasteful and extravagant; at least it seems to be so in the light of the experience in libraries in the same matter.

CHAPTER XIII

Leather: General Notes

The names given to different kinds of leather come sometimes from the character of its surface, that is, from the "grain," or roughness or corrugation it has; sometimes from the animal it once covered; sometimes from the method of tanning; sometimes from the fact that it is part of a skin which has been split; sometimes from the place or country where it is made or where the animal it once covered lived, and sometimes from a combination of two or more of these.

The subject of the leathers used in bookbinding is a very difficult one. Tanners, dealers and binders, dictionaries, encyclopædias and books on tanning disagree with one another as to the proper terms to use in speaking of different kinds of leather. Imitations are many, and very successful. In the list below I have tried to follow the usage of binders; but I am sure no expert would accept it throughout as correct.

With this variety in definition goes a corresponding variety in character in leather of the same name. Different skins tanned in the same way, apparently, and called by the same name by dealers and binders, will wear, some well, some not so well. The only

quite definite assertion which can be made is, that of modern leathers, few save the best morocco and pigskin will keep their strength for any length of time in an American library, and morocco and pigskin usually for not much over 20 years.

As the remarks which follow indicate, English leather makers have recently procured leathers guaranteed to be dressed on the lines recommended by the Society of Arts Report. See also the revised report, and the little volume, with samples, called *Leather for Libraries* by Hulme, Parker and others.

Leathers made from the skins of animals of the same kind, the goat for example, though made by the same process, vary somewhat with the animals' sex, age when killed, the food on which they lived, the climate in which they matured, and their manner of life, and, if females, with the fact that they have or have not had young. Also, the leather made from the skin of one part of the body differs materially from that made from the skin of another part.

Moreover, some dyes seem to hasten decay, some to retard it. Red seems least hurtful, black the most so; though this difference is probably due more to chemicals used in the preparation of the skin for the dye than to the dye itself. Brown generally stands well; most other colors, except red as stated, do not.

With all these, and other, factors to be taken into consideration it is evident that full knowledge of leather is not given to anyone. In a general way it may be said that good leather cannot be told by

name, or looks, or feel; but only by trial. Dealers, even, cannot tell the good from the best.

The sum of all advice is, having found, by your own or others' tests, that a certain leather is good, use it as long as you can get it. The British museum sets a good example in this. It has in recent years bound many thousands of volumes in morocco made by Meredith-Jones & Sons, Wrexham, Wales, which experience thus far shows to be very good. We have tried it and in the brief trial we have given it, found it excellent.

Dr. J. Gordon Parker, Herold's Institute, Drummond Road, Bermondsey, England, has made an arrangement with the council of the Library Association of England by which he has become their official examiner of leather and he will test samples for acids, nature of tannage, etc., at reasonable rates.

John Muir & Son, tanners and curriers, Beith, Scotland, offices: 3 Arundel St., Strand, London, W. C., England, prepare pigskin for bookbinding; so do Edw. & Jas. Richardson, Elswick Leather Works, Newcastle-on-Tyne, England.

J. Meredith-Jones & Sons, Ltd., Cambrian Leather Works, Wrexham, Wales, make bookbinders' leathers guaranteed to be dressed on the lines recommended by the Society of Arts Report, and free from mineral acids. Specialty: Welsh sheep.

Much has been written on the wearing and lasting qualities of leather. The best discussion of the subject is the Report of the committee on leather for bookbinding, made to the Society of Arts, Eng-

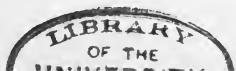

land, and published in its Journal, July 5, 1901. I allude to this report frequently, and for convenience speak of it as "Report '01." The committee who made this report found that the leather made today does not last as long as that made 75 years ago. They found that the heat and fumes of gas help to hasten the decay of the leather on books. These factors are more effective in American superheated libraries than in English ones. If books bound in leather are much handled they last longer than if they stand undisturbed on the shelves, because the oil from the hand helps to keep leather soft, pliable, and alive. The committee concluded that no leather, with the sole exception of Niger goat, made by the natives on the river Niger in Africa, and imported just as it leaves their hands, can be fully recommended as free from elements which lead to its early decay. Since this report was published imitations of this leather have been put on the market, and it can no longer be relied upon. We have found it beautiful in color and texture, easy to work and wearing admirably on large and much-used books. But it does not keep clean as well as a good morocco of coarse grain. It is very expensive, and first-class morocco is probably better where strong, enduring leather is advisable which is only on books which are to be much used.

The most important points made in the report of the Society of Arts committee on leather for book-binding, referred to above, are the following:

Books bound during the last 80 or 100 years show

far greater evidence of deterioration than those of an earlier date. Many recent bindings show evidence of decay after so short a period as ten or even five, years. Modern leather is certainly far less durable than old leather.

The most prevalent decay is a red decay, and this may be differentiated into old and new, the old red decay being noticeable up to about 1830, and the new decay since that date.

Another form of deterioration, more noticeable in the newer books, renders the grain of the leather liable to peel off when exposed to the slightest friction. This is the most common form of decay noted in the most recent leathers.

Decay is caused by both mechanical and chemical influences. Of the latter some are due to mistakes of the leather manufacturer and the bookbinder, others to the want of ventilation, and improper heating and lighting of libraries. In some cases inferior leathers are finished (by methods in themselves injurious) to imitate a better class of leathers, and of course where these are used durability cannot be expected. But in the main the injury for which the manufacturer and bookbinder are responsible must be attributed rather to ignorance of the effect of the means employed to give the leather the outward qualities required for binding, than to the intentional production of an inferior article.

Embossing leather under heavy pressure to imitate a grain has a very injurious effect.

The shaving of thick skins greatly reduces the

strength of the leather by cutting away the tough fibers of the inner part of the skin.

The use of mineral acids in brightening the color of leather, and in the process of dyeing, has a serious effect in lessening its resistance to decay

Quite modern leather dyed black seems, in nearly all cases, to have perished, although old black morocco (sixteenth, seventeenth and eighteenth centuries) in good condition is not uncommon.

In a very large proportion of cases the decay of modern sumac-tanned leather has been due to the sulphuric acid used in the dye bath, and retained in the skin.

Tobacco smoke has a darkening and deleterious effect on leather bindings.

Light, and especially direct sunlight and hot air, possess deleterious influences which had scarcely been suspected.

Gas fumes are the most injurious of all the influences to which books are subjected, no doubt because of sulphuric and sulphurous acid they contain. They are especially injurious to books on the upper shelves of a high room.

The importance of moderate temperature and thorough ventilation of libraries cannot be too much insisted on. With proper conditions of ventilation, temperature, and dryness, books may be preserved without deterioration, for very long periods, on open shelves.

On the other hand, as a general rule, tightly fitting glass cases conduce to their preservation.

Leather bindings that have been coated with glair or varnish seem to keep better than those without.

The bookbinder shares, in no small measure, with the leather manufacturer and librarian, the blame for the premature decay of leather bindings.

Books are sewn on too few and too thin cords, and are not firmly laced into the boards. This renders the attachment of the boards to the book almost entirely dependent on the strength of the leather.

The use of hollow backs usually throws too much strain on the joints in opening and shutting the book.

If the headbands are not strong the leather of the back is apt to become torn.

The leather is often made very wet and stretched a great deal in covering, with the result that, on drying, it is further strained, almost to breaking point, by contraction, leaving a very small margin of strength to meet the accidents of use.

The use of oxalic acid for washing backs of books, or of leather for bookbinding, is fatal to durability. Vinegar, even in its pure state, is injurious.

Paste should be used in a fresh condition, otherwise it is liable to undergo an acid fermentation, and to favor the growth of injurious moulds and bacteria.

In all contracts and specifications for bookbinding, the use of East India-tanned goat and sheep, whether retanned or not, should be absolutely forbidden.

It appears to be the general opinion that leather, and especially Russia leather, lasts better on books that are in constant use. This is attributed to the

slight amount of grease absorbed by the leather from the hand, and it is suggested that possibly a suitable dressing may be discovered which would have a similar effect to that produced by this grease.

While the leather now used for binding books is less durable than that employed 50 years and more ago, there ought to be no difficulty in providing leather at the present time as good as any previously made.

It is possible to test any leather in such a way as to guarantee its suitability for bookbinding.

A reissue of the report summarized above was published, in cloth, in 1905. It is entered in the list of books at the end of this volume. In this reissue the arrangement of the original report is somewhat modified; a paper on leather dyes and dyeing has been added; the report of the scientific sub-committee has been practically rewritten; many illustrations have been added, some of them colored; 12 samples of leather prepared in accordance with the committee's conclusions are inserted; and the volume is handsomely printed, and bound in cloth. The reissue, however, does not make necessary any change in the above summary.

CHAPTER XIV

Paper and Paper Making

Much of the paper used in books today is made of wood. Wood is converted into paper-making material in three ways. In one, it is cut into convenient lengths, stripped of its bark and finely ground on grindstones, and bleached. The product is called ground wood pulp. The paper made from this pulp is hastily and cheaply put together, has little strength, and soon turns yellow and grows brittle. There is often added to ground wood before making it into paper, more or less sulphite or soda pulp, usually the latter, the product of another process of turning wood into paper-making material.

In the sulphite and soda processes the wood is freed of bark, cut into small pieces, and reduced to a pulp by being heated with water and chemicals under pressure in an air-tight steel tank or boiler. Sulphite and soda pulp, which get their names from chemicals used in reducing the wood to pulp, have longer and better fiber than ground wood pulp. In both processes certain means are used to whiten the fiber and free it from sap, gum, and other things which would prevent it from acting properly in the paper-making machine, or would tend to make it grow yellow or spotted. Spruce or basswood are

the woods chiefly used, and they seem to submit themselves to treatment better and to give a longer fiber than other kinds. The pulp made from rags is often mixed with sulphite and soda pulp. The rag-pulp fiber improves the quality of the resulting paper for reasons not easily set forth. Paper made entirely of wood may be of good quality, especially sulphite papers. The popular outcry against wood paper is based on the fact that much of it is made very cheaply and poorly.

The rags used in paper making are nearly all cotton. They are not all of them rags in the ordinary sense of the term. Many of them are cuttings from clothing factories and have never been used. New rags do not act the same way under the treatment which changes them to paper pulp as do the old ones. The paper made entirely from new cloth differs somewhat from that made from old rags. The best book papers, however, contain only stock prepared from old rags.

The process of changing rags into paper is very similar to that of changing wood into paper. The rags are cleaned, freed from foreign substances, cut into small pieces, thoroughly washed, bleached, and then beaten to a pulp, under water, by machines which convert them into a soft, homogeneous, creamy mass, called technically stuff, and yet preserve the greatest possible length of fiber. This process of beating rags into good paper-making material requires care and considerable time. If the process is hastened unduly the resulting material is not so good.

Paper is made from other materials besides wood and cotton; but nearly all of that used in books in this country is made of one or other of these two materials, or of a combination of the two.

The stuff produced as described, almost milk-like in its consistency, is pumped from a tank, in which it is kept constantly stirred to prevent the fiber from settling, onto the paper-making machine. This machine is an evolution from a simple hand appliance which was used by paper makers for several centuries. It was a shallow tray with a bottom made of a network of wires. This was held in the hands, dipped into a vat containing the paper-making material, and as much of the latter taken up on the wires as in the judgment of the maker was sufficient for a sheet of paper. It was then shaken gently, and deftly handled, until the water, running through the wires, left on the latter, and spread evenly over them, a layer of fibers. These dried and matted together in a few seconds sufficiently to enable the maker to turn them out on a blanket; on this another blanket was spread, and on this was laid another layer of fibers. The skilful maker of paper by hand (in a few places in this country the craft is still practiced) can secure considerable evenness in the layers of fiber or pulp on the wire of his frame; but the layer is never of quite the same thickness throughout. Handmade paper can sometimes be distinguished by these variations in its thickness. Machine-made paper is of nearly uniform thickness. In the process of taking up from the vat by hand a thin

layer of stuff, the maker wove together the fibers in every direction by skilful and delicate movements of the frame. A paper-making machine cannot so thoroughly interweave the fibers. Paper made by hand, therefore, has a quality which cannot be secured on a machine. This peculiar texture of handmade paper of the first class delights the connoisseur, and furnishes a printing surface superior, in some respects, to any machine-made paper.

The paper-making machine consists primarily of an endless roll of wire screen, similar to that forming the bottom of the shallow tray used in making paper by hand. This wire screen, stretched around rollers, travels almost horizontally away from a broad shelf from which it receives a stream of stuff pumped onto the latter from the tank before mentioned. As the pulp pours out onto this wire it settles over the screen, and is woven together by the latter's oscillating and forward movement, and by the time it reaches the end of the screen is sufficiently matted and dry to hold its shape, the water being removed by suction. It is then picked up by a roller, and goes through a succession of rolls, varying in size, number, character, heat and pressure, according to the quality of the paper being made and the surface desired thereon. In some cases, toward the close of the process, it is passed through a tank containing a thin mixture of glue and water, called size, and then is again dried. Coming out as paper at the end it is cut into lengths and piled, or gathered on a roll.

The wire diaphragm onto which the paper pulp

first pours, and during the passage over which it is worked into a mat, the water meanwhile being extracted from it, is of varying styles. If perfectly plain the resulting paper is almost without marks, and is said to be wove. If made of wires of different sizes properly arranged the paper, as it lies on it, receives deeper impressions from the larger wires than from the smaller and the former appear as light lines running through it when finished. Paper thus marked is called laid, to distinguish it from the wove. As the paper comes from the wires it passes under the dandy roll. This roll sometimes has figures or letters raised on its surface. These impress themselves on the soft paper and produce a greater transparency where they touch, sometimes reducing the thickness, and give the finished paper what is called a watermark. It is so called not because it is made of water or by water, but because it looks as though it were drawn on the paper with a point dipped in water.

Endless varieties of paper can be made from the same materials. It may contain more or less rag; may be beaten to a greater or less extent and with more or less care; may be spread thicker or thinner; may be rolled on hot rolls, or polished, more or less; may receive more or less sizing; may be dyed in a vat before it starts for the machine, or dipped in dye after it is made, or color may be applied to one surface by machine. The fiber may be carelessly produced, and the chemicals used in bleaching and cleaning it may be only partially neutralized, with

the result that the paper will soon act as if being eaten with acid, and will rapidly turn yellow under a bright light.

The ordinary observer can distinguish between very poor and fairly good paper in books. He cannot distinguish between paper of fairly good quality and the best.

The paper used in newspapers is nearly all made entirely of ground wood. Most of it is made as cheaply as possible, and soon grows brittle and dark in color. This is of little consequence in most cases. For the ordinary newspaper the paper has served its purpose if it looks well for twenty-four hours after it is printed and exposed to the light.

Books are generally printed on paper which has not been very highly polished. Ink is taken from the type more readily by paper of this kind, especially if the latter be rather soft in texture, so that the press drives into it the face of the type bearing the ink. Modern processes of reproducing pictures give plates for printing, many of which are made up of very fine lines placed very closely together and having very shallow depressions between them. To print from these with good results the paper used must have a very smooth, highly polished surface. The press drives soft paper down into the narrow places between the fine lines and blurs the impression of the cut. Newspapers which use process-cuts of the kind mentioned are obliged to use paper with a smooth surface to get good results. This smooth surface is generally produced, as already noted,

by passing the paper between hot metal rollers, a process called calendering. In a more expensive process, called plating, the paper, cut into sheets, is laid between sheets of zinc until a pile of several inches in thickness is formed, and this pile is passed several times under rollers exerting a heavy pressure. This smooths, polishes and hardens the paper. Much of the paper used for illustrations in books has a surface made by applying a coating of clay or other material to it and then polishing it. Quite good results can be obtained with fine line cuts on calendered or plated paper without the addition of a coating of clay. The illustrations on coated paper which are found in books are very commonly printed separately from the book itself, which is on ordinary uncoated paper, and inserted separately. Generally these inserts are not carefully fastened in and cause much annoyance by falling out after the book has been subjected to a little use.

Recently paper makers have succeeded in producing a paper which has a smooth surface without the high polish usually found on that which is coated, or highly calendered. The polished surface of these papers, especially of the coated, is very objectionable to readers, light being reflected from it in an unpleasant way.

It will be seen from what has been said that it is difficult so to describe what we may call good book paper that it can be readily distinguished. Constant study and careful comparisons of the papers one meets in books will enable one to judge of them

with some success. One who has much to do with books should take note of the paper of which they are made, and learn to distinguish between poor and good, and the good and the best, as far as possible. This is especially desirable for one whose work with books includes their rebinding and repairing. Coated paper breaks easily, the stiffening added to it by the coat of clay giving it a tendency to fall apart as soon as it has been folded in the same place a few times. Soft and fragile paper, such as is found in many books, will stand very little wear at the joint in the back. Paper not carefully bleached and freed from the chemicals used in bleaching, rapidly discolors at the edges where exposed to light. Such facts as these, and many others, will be found useful when one comes to have books rebound, or attempts to repair them.

That side of the paper which touched the wires on which it is made is different from the other. This difference is usually visible to the trained eye. It is often taken into consideration in fine printing.

As the pulp flows out upon the wires it tends to mat together more thoroughly along the line of flow than across it. This gives paper a grain, along which it tears and folds more readily than across it. This fact also is often taken advantage of in good printing.

All paper expands or stretches when wet. This is to be kept in mind in mending books. An added strip, pasted on, usually draws and wrinkles, when it dries, the paper to which it is applied. Hence the rule, in mending, to use thick paste and apply the

pasted sheet or strip to its place as quickly after pasting as possible.

Mr. Chivers has recently made, 1909, with the help of chemists and other experts, a very careful examination of the composition, structure, tensile and folding strength and other qualities of the paper now used in several thousand popular books. The results of this examination, when applied to the subjects of book-selection and book-buying, will be of great value to libraries. The quality of the paper used in the books on which libraries spend a large per cent of their book fund—novels—is the question that should be first considered in selecting editions. Libraries may hope soon to be able to select editions much more wisely than heretofore. The investigations by Mr. Chivers, and those carried on by U. S. Government experts in Washington, will not only enable libraries to discover the best editions for purchase, but will also enable them to secure bindings so carefully adapted to the quality of the paper in each book as to give that book the longest possible life of usefulness.

CHAPTER XV

Binding Records

By binding records are meant the reports of books sent to the bindery, their return, styles, cost, etc. There are many ways of keeping these. For the small library great simplicity is desirable and possible. The large library usually works out a method adapted to its own conditions.

In sending books to a binder it is usually not necessary to keep any record other than the book card, on which may be written or stamped the word Binder and the date sent. To this may be added a few words or a number indicating material and style. The binder himself is usually content with general instructions for each separate lot, such as, "These 25 vols. bind in half brown cowskin with keratol sides; special sewing." Some libraries attach a note to the title-page of each book saying how it is to be bound and giving the lettering for the back. This is not often necessary. It is usual to note the latter point on the title page by underscoring the first letter of each word which is to appear on the back. In doing this, reduce the lettering as far as possible by omitting unnecessary words. In most libraries, for example, the new title for "The Adventures of Huckleberry Finn" can be reduced to advantage to "Huck Finn."

Special books must be specially marked of course, and books in sets and series should be lettered in the same style throughout. This can be assured by sending a sample volume or a rubbing of the back. The rubbing is got by laying a piece of paper on the back of the volume the style of which is to be copied and rubbing it hard with a large, soft pencil or rub-off wax.

As books are returned they should be checked by whatever record was kept of them. Then their number, sizes and styles should be entered in a book kept for the purpose. From these items the bill will be checked when sent in.

CHAPTER XVI

Binding Records and Notes, Newark

Rules followed in Newark Library in sending books to bindery.

Remove book slip, having first compared its number with the number on the book pocket. This book slip is stamped with the word Bindery and with the date, and then is filed with other similar slips, all being kept in groups in accordance with the kinds of binding the books are to receive. The slips for the books sent each month are also put together.

On the title page of the book underline with light pencil marks such words as are to be gilded on the back. Make the title for the back as short as it can be made without loss of identity. If the name on the title page is a pseudonym, write the author's correct name beside it in small letters.

Most books are sent in groups with a general note of instruction as to the binding of the whole group. For example, a hundred books may be sent in one lot with a note saying, "Bind in pigskin in the usual style."

When special bindings are required, which call for special instructions, tip slightly in the front of the book, usually on the title page, a slip of yellow paper 3x5 inches. Bright yellow is chosen because it is

easily distinguished from the white paper of the book, even at night, and yet writing on it is quite legible. On this slip write the call number of the book, the special style of binding wanted and other remarks when needed, such as the following:

Rush. If the book is to be returned in haste.

See sample. When book is one of two or more volumes and a special style of binding is to be carried out through the whole set.

Do not trim at all. When the book is of some special character and it is desired to preserve all the paper.

When books come back from the bindery stamp the date of their return on the lower left corner of the back cover immediately on their receipt. Add to this date the name of the binder if the library employs more than one firm.

This date makes it possible to tell how bindings wear, how many years they last, etc.

Note the style of binding of each book and look for its book slip among the other slips for books of this style.

For some reasons it would be wise to keep the slips from all books sent to the bindery in one alphabetical series. In the Newark Library this proves not to be as convenient as the method described, of keeping it first by days or months and next by styles of binding.

Examine the lettering and the numbers on the back to see if they are correct, comparing with the title page. Examine also the binding throughout.

If all is satisfactory, put pockets and book plates in all the books which require them.

Mark the pockets. Open each book carefully and thoroughly that the back may be loosened and made more flexible.

All magazines send with yellow slips containing directions as to style of binding, etc.

CHAPTER XVII

Bindery Equipment

The small library will find it does not pay to have a bindery of its own. This is a safe general rule to which there are exceptions, of course. Special conditions, such as remoteness from good binderies, may make it worth while for a library which spends only about \$1,000 a year in binding to put in a small plant and do its own work. Even then, however, it is usually better to find a binder who will take the contract from the library at a fixed price per volume, using the library's room and material. Such a binder can sometimes get additional work from other libraries or from private individuals. It should be noted that the amount paid for binding is not quite all that a binder who works in the library may expect to divert to his own shop; for a clever and obliging workman will make himself useful in repairing and in doing many small jobs of cutting, mounting, etc., which will add a good deal to his income. Still, as I have said, the small library will usually find that it is not economical to have its own bindery. Were there in this country plenty of commercial binderies, where first-rate work is done at fair prices—I do not mean low prices—it would not pay even the larger libraries to open their

own binderies. The large shop is the only place in which some of the most important economies are possible, and only the large shop can afford to hire the most competent foremen and workers. Even the large libraries find it wise to rent their binderies to competent men who will do binding at contract prices. Under this arrangement some libraries find it pays to give up room to a bindery; though, as I have already remarked, they would not find it economical to do so were there efficient library binding establishments in the immediate vicinity.

As the large libraries have a good deal of work which the average commercial binder does not care to take, like map mounting, rare-book mending, and ordinary book repairs, the ideal condition for them would be a small bindery with two or three hands, in the building; a contract for all ordinary binding and rebinding with an outsider, and the purchase of many new books especially bound direct from the sheets.

The following list includes the machinery, tools and materials needed in opening a bindery. The full list would equip fairly well a shop employing one foreman, who is also a finisher; one forwarder; one boy (helper or apprentice), and three girls for sewing. This shop would turn out, say, 10,000 books a year, its output depending very largely on the character of the work.

If the shop is to bind, say, only 2,000 books per year the items marked S on the list will prove sufficient. These estimates are very general.

Equipment for Bindery

Standing press, large.....	\$100.00
S Standing press, small	30.00
S Board shears	\$100 to 125.00
S 2 backers, 17-inch.. ..	65.00
S Cutting machine	325.00
S 10-case type cabinet (6-case \$8.00).....	12.00
S Finishing press, 21-inch.....	2.75
S Lettering pallet... ..	6.00
S 20 brass-bound boards, 16x24, at \$3.25 per board	65.00
Case for 14 boards.....	4.00
16 press boards, 16x24.. ..	16.00
16 press boards, 10x13... ..	7.20
14 press boards, 8x12... ..	5.60
S 3 sewing benches, at \$1.00.....	3.00
S 2 back saws, at \$1.00.... .	2.00
S 3 bone folders.....	.36
S 1 glue brush, No. 4.....	1.00
S 2 paste brushes, No. 7.	2.00
S 2 backing hammers, at \$1.25.....	2.50
S Knives and shears.....	3.00
S Gas stove.....	1.00
Iron bench-block, 15x12x2 inches.....	7.50
S Glue kettle.....	1.00
Compass.....	1.00
S Gold cushion.....	3.00
S Gold knife.....	.75
4 tables, benches, drawers.....	100.00
S Paring knife.....	.50
S Band nippers... ..	2.00
S Flat polisher.....	2.00
S Round polisher.....	3.50
S Creaser.....	1.50
S Agate burnishers.. ..	3.75
S Band rubber.....	1.50
Rolls and stamps.....	20.00

S Type, ordinary, 4 fonts at \$3.00; brass, 3 fonts at \$15.00.....	\$ 57.00
Shelving and bookcases.....	100.00
Total.....	<u>\$1083.41</u>

With treble the number of books to be bound, there should be added to the above list:

1 large press.....	\$100.00
1 backer.....	65.00
1 finishing press.....	2.75
30 brass-bound boards, 16x24, at \$3.25 per board	97.50
5 sewing benches, at \$1.00.....	5.00
1 back-saw, at \$1.00.....	1.00
5 bone folders.....	.60
1 glue brush, No. 4.....	1.00
3 paste brushes, No. 7.....	3.00
2 backing hammers, at \$1.25.....	2.50
Glue kettle.....	1.00
Compass.....	1.00
Knives and shears.....	3.00
Gold knife.....	.75
Paring knife.....	.50
Band nippers.....	2.00
Type.....	15.00
Lettering pallet.....	6.00
Iron bench block.....	7.50
Total.....	<u>\$315.10</u>

CHAPTER XVIII

List of Technical Terms, Leathers and Other Binding Materials, Tools, Styles of Ornament Used in Binding

The quotations are from the report of committee on leather of the Society of Arts, England, 1901.

Aldine or Italian Style. Ornaments of solid face without any shading whatever, such as used by Aldus and other early Italian printers. The ornaments are of Arabic character. A style appropriate for early printed literature.

All-along. When a volume is sewed, and the thread passes from kettlestitch to kettlestitch, or from end to end in each sheet, it is said to be sewed all-along.

American Russia. See Cowhide.

Antique. See Blind-tooled.

Arabesque Style. A fanciful mixture of animals, birds, insects, and of plants, fruits and foliage, involved and twisted.

Arming press. See Blocking press.

Art canvas. A book cloth, made in several colors by the Holliston Mills, 67 Fifth Ave., New York; Jos. Bancroft & Sons, Wilmington, Del. (A. D. Smith, 35 Thomas st., New York, agent); the Interlaken Mills, 111 Duane st., New York, and others.

It is known both as art canvas and buckram. The Newark library, in experimenting to find a substitute for leather, tried in succession the green, red, brown and blue. The green proved the poorest, the blue made by Holliston Mills the best in wearing quality. One reason for the poor results with all the colors tried, with the exception of the blue, is that the cloth of these colors is made with a colored thread running one way and a gray or white thread the other; the colored thread soon wears off on the edges and corners and the gray thread gives the book a very dingy appearance. Dark blue has given us the best results. Art canvas costs 22 cents a square yard by the roll of 40 yards.

Art vellum. A book cloth made in several colors and styles of finish by the firms which make art canvas. It is not suitable for full binding on books subject to much wear. It costs about 16 cents per square yard. Most publishers' bindings are in cloth of the art vellum grade.

Our own experience with art canvas and art vellum for full bindings on books much used seems to have been that of many other libraries. Popular books in these materials from about a dozen public libraries all seem to have worn poorly. The joints soon become soft and loose; the corners fray out and look ragged; the gold of the titles does not stand out well when first put on and rapidly grows dim.

Azure' tools. Used in binding, where the heavy and wide marks, instead of being a solid mass, are made with horizontal lines.

Azured style. Ornamentations outlined in gold and crossed with horizontal lines in the manner of indicating azure in heraldry

Back, tight and loose. Binding is said to be tight back when the leather, cloth or other material of the back is pasted or glued to the back of the book. This style of binding is commonly used in fine work. Most books, often quite large ones, were formerly bound in this way.

Binding is said to be loose back when the leather, cloth or other material of the back is fastened to the book only along the joints. To the question, which is the better binding for library books, no definite answer can be given.

Backing. Bending over the folds at the back of a book to form a ridge or projection called a joint.



Backing Boards, Metal

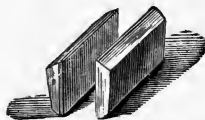

**Backing Boards, Wood,
Steel Faced**

Backing boards. Used for backing or forming the joint. They are made of very hard wood or faced with iron, and are thicker on the edge intended to form the groove than upon the edge that goes toward the fore-edge of the book, so that when placed one each side of the book and all are placed in the laying

press, the whole power of the press is directed toward the back.

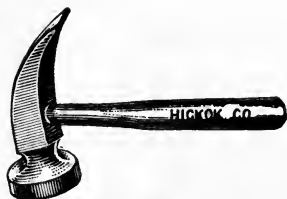

Backing Hammer

Backing hammer. The hammer used for backing and rounding. It has a broad, flat face similar to a shoemaker's hammer.

Backing machine. A machine for backing books. If not carefully handled it

is apt to injure books by crushing and breaking the paper at the folds. Used on publishers' binding.

Backing press. A press having two, vertically mounted, steel plates brought together by a screw. A book is held in this press with the back slightly projecting above the plates, and then backed with a hammer.

Band-driver. A tool used in forwarding to correct irregularities in the bands of flexible backs.

Band nippers. Pinchers with flat jaws used for straightening bands by nipping up the leather after it is in place. They should be nicked to prevent the iron staining the leather.

Bands. The strings, cord or twine on which a book is sewed. They are usually made of hemp, are loosely twisted, are 2, 3, 4-ply according to the size of the book, and cost about 35 cents per pound. This twine is loosely twisted that it may be flexible and less likely to break when glued and dried, and that it may be easily frayed out at the ends for pasting down on the inside of the covers.

When the book is sewed flexible the bands appear upon the back. When the back is so sawn as to let



Backing Press

in the twine, the appearance of raised bands is produced, if at all, by gluing narrow strips of leather across the back before the volume is covered. A

hard, closely twisted cord is also sometimes used in fine binding.

Bastard title. See Half-title.

Bead. A little roll formed by the knots of the headband.

Beating hammer. The heavy, short-handled hammer used in beating, weighing generally about 10 lbs. Books are beaten to make the leaves lie close to one another.



Beating Hammer

Beating stone. The bed of stone or iron on which books are beaten.

Beveled boards. Very heavy boards for sides, chamfered along the edges.

Binder. A temporary cover for periodicals and pamphlets, usually so arranged that it may be taken off and attached to successive numbers of a publication.

Bindery. A book-binding establishment.

Blank books. Applied to a large variety of books which are bound with blank leaves, or leaves having ruled lines and little or no printing: account books, memorandum books, ledgers, etc. The binding of such books is a special trade.

Bleed. When a book on being trimmed is so cut that some of the print is taken off it is said to bleed.

Blind-tooled. When tools are impressed upon the leather, without gold, they are said to be blind or blank, and the book is blind-tooled. This tooling is sometimes called antique.

Blocking press. Another and more general term for the stamping or arming press; one of the chief implements used in cloth work. Used for finishing or decorating the sides and back of a cover by a mechanical process.

Board papers. Those parts of the end papers which are pasted onto the boards.

Board shears. Heavy shears, usually fitted to a table, and with a gauge for cutting boards.

Boards. Are of several kinds, such as pressing, backing, cutting, burnishing, gilding, etc. The paste-

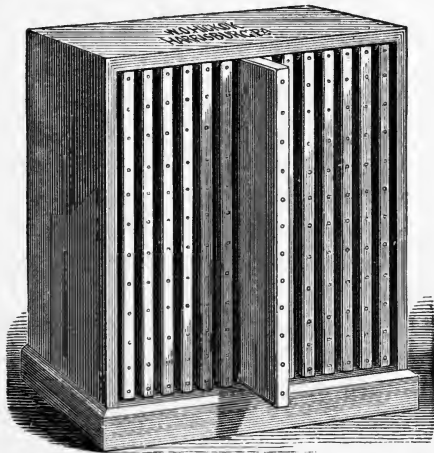

Boards, Brass Bound, in Case

boards used for side covers are termed boards. The boards used for cutting books "out of boards" are called steamboat-boards. Tinned boards are used for finished work, while brass or iron-bound boards

are used for pressing cloth-work. See also In boards.

Bock morocco. The name given to a leather made of Persian sheepskin usually finished in imitation of morocco. It does not wear well and soon decays.

Bodkin or stabbing-awl. A strong point of iron or steel fixed in a wooden handle to form the holes in boards through which to lace bands. Used also for tracing lines for cutting fore-edges.

Bolt. Folded edge of sheets in an unopened book.

Books, sizes of. See folio, quarto, octavo, sixteenmo, thirty-twomo, etc.

Bosses. Brass or other metal ornaments fastened upon the boards of books.

Brass-bound boards. See Boards.

Broken up. When plates are folded over a short distance from the back edge before they are placed in the book, that they may be turned easily, they are said to be broken up. The same process is sometimes applied to an entire book.

Buckram. Properly a coarse linen cloth, stiffened with glue or gum. Most buckram, so-called, is made of cotton. See also Linen-finish buckram and Art canvas.

Buffing. The name given to the thin sheet of cowhide taken off in the operation of buffing or splitting. It is usually of very inferior quality.

Buffingette. See Keratol.

Burnished. The effect produced by the application of a burnisher to edges.

Burnishers. Pieces of agate or bloodstone affixed to handles. With them a gloss is produced on the edges of a book.

Calf or calfskin. Leather made of calves' skins. It has a smooth and uniform surface. It was formerly much used in binding, and is very beautiful; but that made in recent years lasts only a short time, soon growing hard and brittle and even falling into dust. Even when new the surface is easily broken and torn.

"During the latter part of the eighteenth century it became customary to pare down calf until it was as thin as paper. Since about 1830 little sound calf seems to have been made, as, whether thick or thin, it appears generally to have perished, turning red and crumbling into dust."

"Sprinkled or marbled calf is in a specially bad state."

See also Divinity, Kip, Marbled, Sprinkled and Tree calf.

Calf-lined. When the inside of a limp cover is lined with calfskin, this taking the place of that half of the end paper which is usually on the inside of the cover. This calf lining is thin and soft and is usually glued to the leather cover only at the latter's outer edges, thus leaving the cover pliable.

Cancel. Leaves containing errors which are to be cut out and replaced with corrected pages.

Canvas. See Duck.

Caps. Paper coverings used to protect the edges while the book is being covered and finished. Also

the leather coverings of headbands. See Head cap.

Case bindings. The ordinary cloth binding of commerce. Books in these bindings are folded and sewn, rounded and backed by machinery. A machine also makes the cases, covering the two pieces of cardboard which form the sides with cloth as needed. These cases are separately printed before being put on the books. The book is then glued and put into its case by machinery.

Catchword. A word placed under the last line on each page of some old-time books, the word being the same as the first word on the next page; a direction word.

Center tools. Tools cut for ornamentation of center of panels and sides of book covers.

Circuit edges. Bibles and prayer-books are sometimes bound with projecting covers turned over to protect the leaves; these are called circuit or divinity edges.

Clasp. A hook or catch for fastening the covers of a book together, usually at the fore edge.

Clearing out. Removing the waste paper and paring away superfluous leather upon the inside, preparatory to pasting down the lining-paper.

Cloth boards. Stiff boards covered with cloth.

Cobden-Sanderson style. An arrangement of graceful curves or stems, flowers, buds and leaves, treated conventionally; the background being often powdered with nebulae of gold stars or dots. The lettering of title, etc., on back and sides is treated fanci-

fully and often made an integral part of the design.

Collating. Examining the signatures, or sheets, after a volume is gathered, to ascertain if they be correct and follow in numerical order. Also, examining a book page by page to see if it is complete.

Combs. Instruments with wire teeth used in marbling. The colors being upon the surface of water, the comb is drawn across a portion in such a way that a new form is developed.

Corners. Leather pieces pasted on the corners of a half-bound or three-quarter-bound book.

Cowhide. The thick, coarse leather made from the skin of a cow. By binders it is commonly known as "American Russia," or "imitation Russia." It is much used for binding popular books of fiction. It has a slight grain or corrugation on the surface, is tough and strong, takes gilding well, wears well and if of best quality and handled much is usually quite durable; that is, will last five or six years on popular fiction.

Creaser. The tool used in marking each side of the bands, generally made of steel.

Cropped. When a book has been cut down too much it is said to be cropped.

Crushed. Leather which has been pressed between sheets of metal to smooth or give a finish to its coarse grain is said to be crushed. The process is usually applied to morocco or its imitations. See Crushed levant.

Crushed levant. Levant morocco, with the grain crushed down until the surface is smooth and highly polished. In fine binding this is done by hand after the leather is on the book. Most crushed levant morocco, however, is surfaced by a machine before it is applied to the book.

Cut edges. See Edges cut.

Cut flush. Means that the cloth cover, which is usually limp (without boards), is drawn on the book and the whole cut at once, cover and all, the edge of the cover being cut flush with the edge of the book. It is a suitable way of binding only when strength and elegance are not required.

Cutter, or Cutting machine. The machine on which the edges of the leaves of books are cut or trimmed. Running such a machine is now a special branch of the binder's trade. Sometimes called a guillotine.

Cutting boards. Wedged-shaped boards somewhat like backing-boards, but with the top edge square; used in cutting the edge of a book and in edge-gilding.

Cutting in boards. Cutting the edges of a book with a plough after the boards are laced on.

Cutting press. When a lying press is turned so that the side with the runners is uppermost it is called a cutting press.

Dandy. A roller affixed to paper-making machines. The wet web of paper carried on the endless wire of the machine passes under this roller and is pressed by it. It gives the laid or wove appearance to the

sheet, and when letters, figures, or other devices are worked in fine wire on its surface it produces the effect known as water-marking.

Deckle-edge. The rough untrimmed edge of hand-made paper. Deckle-edges are poorly imitated by



Oswego Hand Wheel Drive Cutter

cutting and tearing machine-made paper, sometimes with the aid of a jet of water.

Dentelle border. A tooled pointed border with finely dotted or Gascon ornaments in imitation of lace.

Derome style. This style has ornaments of a leafy character, with a more solid face, though lightly shaded by the graver. The ornaments are often styled Renaissance, being an entire change from the Gascon. The Derome is best exemplified in borders, Vandyke in design; it is simple in construction but rich in effect, and is appropriate for art publications. Time, eighteenth century.

Diaper. A term applied to a small repeating all-over pattern. From woven material decorated in this way.

Divinity calf. A dark brown calf bookbinding decorated with blind stamping, and without gilding; so called because formerly used in binding theological books.

Divinity edges. See Circuit edges.

Double. See Doublure.

Doublure. The inside face of the boards, especially applied to them when lined with leather and decorated. When thus lined a cover is said to be "double."

Duck, sometimes called Canvas. This is made by many firms in a wide range of colors and qualities. It is in fact a heavy cotton cloth. Slate-colored duck 28 in. wide, 10 oz. to the yard, costs about 20 cents per yard. This is a firmly woven, smooth material. We have used a light green. It takes printers' ink for lettering fairly well, though it soon soils if handled. It is a very desirable binding for heavy books not much used. All such books should be stiffened by pasting or gluing cloth on the

backs, if loose back, and should be reinforced at head and tail.

Dutch metal. An imitation of gold leaf, sometimes used on cheap bindings. It soon grows dark or tarnishes.

Edges cut. A book or pamphlet cut down sufficiently to make all the edges quite smooth.

Edges gilt. Book edges cut and gilded.

Edges opened. A book or pamphlet opened, the folds of the leaves being cut by hand with a paper knife.

Edges red. Book edges cut and colored red.

Edges rolled. When the edges of the covers are marked with a roll, either in gold or blind.

Edges rounded. Corners rounded to prevent their becoming dog's-eared.

Edges trimmed. A book or pamphlet with the edges cut enough to make them tidy, but not enough to cut the folds of the leaves.

Edges untouched. A book or pamphlet with edges uncut and unopened.

Edition de luxe. Applied to large paper editions of books, and to special editions which are in fact, or are claimed to be, unusually well and expensively made.

Embossed. When a plate is so stamped upon a sheet or cover as to produce a raised figure or design.

End leaves or Lining papers. Are the sheets which are pasted to the inside of the covers, and are either plain white or colored, according to the style of binding. Marbled papers are largely used on fine leather

work. Sometimes in fine bindings the end leaves are made of silk or leather.

End papers. The papers placed at each end of the volume and pasted down upon the boards. Also, the paper placed at each end of the volume, a portion of which is usually removed when the lining-paper is pasted down upon the boards.

English linen or Low buckram. A linen cloth, highly polished, well colored, strong, durable, made in England, and costing in this country about 70 cents per square yard. In De Jonge's list (De Jonge, dealer in leather, book cloths, etc., 69-73 Duane St., New York) it is called Low buckram. We have used it for the backs of books, light and heavy. It promises to stand indefinitely if not much handled. Under handling it grows soft and flabby like other book cloths, though not rapidly, and without losing its strength. We have discarded it for the books on which we first tried it, periodicals subject to much use. It is not easy to letter in gold by hand, and does not hold gold well under wear.

Eve style. A framework of various geometrical-shaped compartments linked together by interlaced circles; the centers of the compartments are filled with small floral ornaments and the irregular spaces surrounding them with circular scrolls and branches of laurel and palm. An elaborate style of the end of the sixteenth and beginning of the seventeenth century.

Extra binding. A trade term for the best work.

Fanfare style. When the compartments on a decorated corner formed by fillets or curves, or both,

are filled with little branches, vines, etc., the style of decoration is said to be fanfare—from its first having been used on a book of which this word formed the principal part of the title.

Fillet. A cylindrical tool upon which a line, lines, or figures are engraved. Used in finishing.

Finishing. The department which receives books after they are put in leather, and ornaments them as

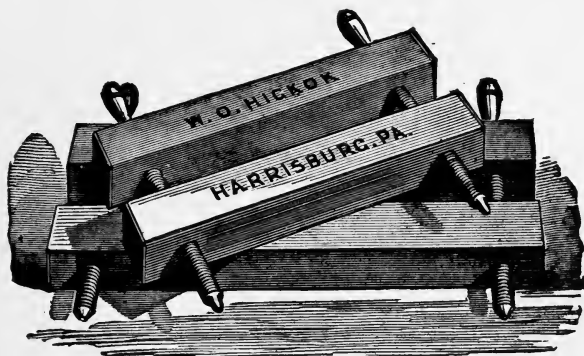

Finishing Presses

required. It includes lettering, tooling, polishing, etc. Also, the ornaments placed on a book. One who works at this branch is termed a finisher.

Finishing press. A small press with which a book is held firmly with its back upward and exposed for work.

Finishing stove. A small gas heater, similar to a "hot plate," for heating finishing tools.

Flexible binding. When a book is sewn on raised bands or cords and the thread is passed entirely

round each band, and the whole binding is such as to permit the book to be opened readily.

Flexible glue. This is usually made by adding about two tablespoonfuls of glycerine to half a pound of the glue in a dry state.

This glue used on the backs of books makes the

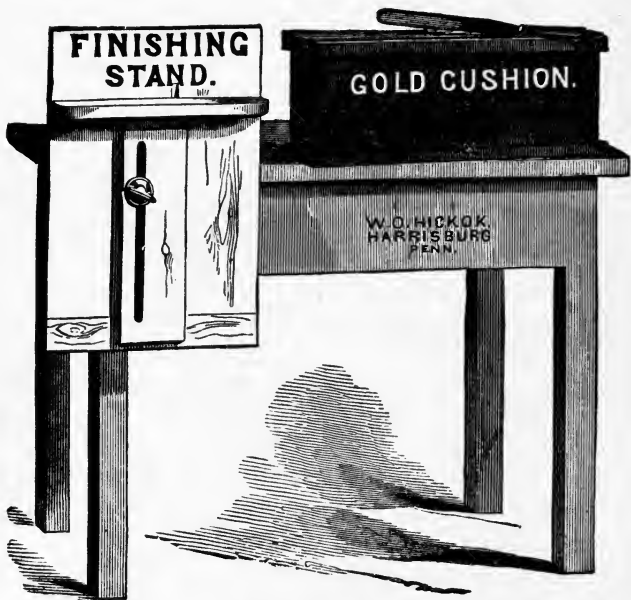

Finishing Stand

binding somewhat more flexible. It cannot be recommended for all books in all cases as the glycerine tends to weaken the glue, at the same time that it prevents it from becoming very hard.

Flexible sewing. When the cord rests on instead of being sunk into the back and the thread is carried around it; a book thus sewn usually opens freely.

Flush cut. See Cut flush.

Fly leaves. The blank leaves at the beginning and end of a book, between the end papers and the book proper.

Folder. A flat piece of bone or ivory used in folding the sheets and in many other manipulations. Also applied to the person engaged in folding sheets.

Folio. A sheet folded once, consisting of two leaves, or four pages; the size of the sheet being usually understood as about 19x24 inches, giving a leaf 19x12 inches. Also, the consecutive page numbers of a book, pamphlet, etc.

Fore-edge. The front edge of the leaves.

Forwarding. All processes through which a book passes after sewing, other than those of ornamentation by means of tools or rolls. Also that department which takes books after they are sewed and advances them until they are put in leather ready for the finisher. One who works at this branch is termed a forwarder.

French guard. Made by turning over half an inch or more of the back edge of a printed sheet or illustration and then folding it around the next signature.

French joint. A joint in which the board is not brought close up to the back, thus giving more play in opening.

French morocco. An inferior quality of levant

morocco, having usually a smaller and less prominent grain.

Full-bound. When the sides and back of a book are entirely covered with one piece of the same material it is said to be full-bound.

Gascon, Le, style. The distinguishing feature of this style is the dotted face of the ornaments instead of the continuous or solid line. Wherever these dotted ornaments are used the style is called Le Gascon. Time, the first half of the seventeenth century, immediately following that of Nicholas and Clovis Eve.

Gathering. The process of collecting the several sheets which make a book and arranging them according to the signatures.

Gaufre edges. Impressions made with the finisher's tools on the edges of the book after gilding.

Gauge. The tool used in forwarding to take the correct size of the volume and to mark it upon the boards for squaring.

Gilding press. A press made of two square blocks brought together by screws, to hold books for gilding.

Gilt. Applied to ornamental work on covers and also to edges of a book; in the latter case, chiefly used for the top.

Gilt edges. See Edges gilt.

Gilt tops. Books with the top edges cut and gilded. This prevents their being soiled by the dust that may collect on them.

Glair. The white of eggs beaten up and used in finishing and gilding the edges of the leaves.

Goffered edges. See *Gaufre* edges.

Gold cushion. A cushion of leather on which the finisher cuts gold leaf into pieces.

Gold knife. The knife for cutting the gold leaf; long and quite straight.

Gold leaf. Gold beaten into very thin leaves, occasionally used for printing purposes, but more particularly for the decoration of book covers

Gouge. A gilding tool cut to impress a curved line or segment of a circle upon the leather

Grain. The term applied to the outer side of a piece of leather, from which the hair was removed. This word is also used in describing the different kinds of surface given to leather in the making, often with a qualifying adjective, as, seal-grain, like the grain on sealskin; coarse grain; pebble-grained, that is, grained in an irregular manner, as though numerous small pebbles of different sizes had been pressed upon its surface; water grain; smooth grain; brass board grain, usually put into cowskin, etc.

Graining. The process of giving to leather surfaces of different kinds.

Grater. An iron instrument used by the forwarder for rubbing backs after they are paste-washed.

Grolier style. An interlaced framework of geometrical figures—circles, squares, and diamonds—with scrollwork running through it, the ornaments of which are of moresque character, generally azured in whole or in part, sometimes in outline only. Parts of the design are often studded with gold dots. Time, first half of the sixteenth century.

Groove. That part of the sections which is turned over in backing to receive the board. Also called the Joint.

Guards. Strips of paper inserted in the backs of books to which plates or pictures or any extra leaves are to be attached. These strips must always be cut with the grain. They make the back as thick as the book will be when the plates have been attached to them. Also, the strips of paper or cloth pasted along the folds of leaves to strengthen them. Also, the strips pasted to the edges of single leaves, whether plates or not, folded about the next signature and sewn through with it.

Books with thick, heavy leaves are sometimes guarded or hinged throughout that they may open freely. A narrow strip is cut from the back of each leaf. This strip is then again attached to the leaf from which it was cut by a strip of thin paper or muslin which acts as a hinge. The leaves are then bound together through and by the strips cut from them.

Guides. The grooves in which the plough moves upon the face of an old-style cutting-press.

Guillotine. A machine with a heavy knife having a perpendicular action, used for cutting paper. Usually called a Cutter, or Cutting machine.

Half-bound. When the back of a book is covered with leather and the sides with paper or cloth. Some binders call a book half-bound when it has leather on the back and small pieces on the corners. Three-quarters bound means wide leather back and large leather corners.

Half-title. The brief title which precedes the main title page, usually a single line in plain type; the bastard title.

Hand letters. Letters fixed in handles; used singly for lettering.

Head and tail. The top and bottom of the back of a book.

Headband. The silk or cotton ornament worked at the head and tail of a book to give it a finished look, to strengthen it and to make the back even with the squares or boards which form the sides. On cheap binding the headband is cut from a strip of machine-made material and pasted in merely for ornament.

Heel-ball. A preparation of wax used by shoemakers, in the form of a ball, in burnishing the heels of shoes.

Head cap. The fold of leather over the headband.

Imitation Russia. See Cowhide.

Imperial morocco cloth. A grain-finished linen-thread cloth manufactured by the Winterbottom Book Cloth Company of England. It is made in different colors; of these the library has tried but one, the green. On books which have some, but not constant use, it is a very good substitute for leather. It takes lettering well, and wears better than any of the cloths the library has tried. The price is 48 cents per square yard by the roll, fast color, duty paid. (De Jonge & Co., 69-73 Duane St., New York.)

In boards. When a book is cut after the boards are affixed to form the sides, it is said to be cut in boards. The term is also applied to a style of binding in which the boards are covered with paper only.

Inset. When one sheet is placed inside of another, both being folded.

Inside margins. The border made by the turn in of the leather on the inside of boards.

Inside tins. Sheets of tin; so called from being placed inside the boards when a book is put in the standing-press.

Jansen style. Without line or ornament either in blank or gold. It permits decoration on the inside cover, but demands absolute plainness on the outside, with the exception of lettering. It is only appropriate for crushed levant, it being dependent for its beauty on the polished surface of the leather.

Javelle water. To one pound of chloride of lime add four and a half pints of water, and put in a jar with tight cover. Dissolve 20 oz. of ordinary washing soda in four and a half pints of boiling water, in a separate vessel, and immediately pour into the first mixture. When cold add enough water to make eleven pints in all. Strain through muslin, settle, and pour off the clear solution. This will remove many stains; but care must be taken to rinse thoroughly the paper with water after using it, as it tends to rot paper.

Joints. The projections formed in backing to admit the boards. Also the leather or cloth, with its lining, where it passes from the book proper to

the boards when the volume is covered; that is, the part of the binding that bends when the boards are opened. See also French joint.

Justification. The process of making the pages of a book lie opposite one another to insure a straight and equal margin throughout.

Keratol, the B B B grade, or Buffingette manufactured by the Keratol Company, cor. Clifford and Van Buren Sts., Newark, N. J., at 35 cents per yard. A waterproof cloth made in imitation of leather. It is excellent for the sides of books which receive much wear, as it does not show either finger or water marks, and outlasts the ordinary book cloth. It cannot be recommended for full binding as it is difficult to letter and wears away quickly at the joints. At first it has a disagreeable odor, but this wears off. An objectionable feature is that labels cannot easily be pasted upon it. To overcome this difficulty, put a thin coat of shellac on the place where the label is to go. The objectionable point mentioned is overbalanced by the material's good qualities.

Kettlestitch. As the sewer draws the thread out through the hole near the end of a signature she passes it between the two preceding signatures and around the thread which connects them, before she passes it into the hole in the signature she next lays on. This is called the kettle-stitch, a word said to be a corruption of either catch-up stitch or chain stitch.

Keys. Little metal instruments used to secure the bands to the sewing bench.

Kip calf. Made from the skin of a heifer; much stronger than ordinary calf.

Knocking-down iron. A heavy iron plate on which are placed the sides of a laced-in book when the lacings of string, tape or vellum, are pounded down with a hammer so they will not show when the book is covered.

Laced in. When the boards are affixed to the volume by passing the bands, strings, or tapes on which it is sewn through holes made in the boards, they are said to be laced in.

Laid paper. Having lines water-marked in it, running through it at equal distances apart, the lines being thin places made by the pressure of projections on the dandy-roll.

Laying press. See Lying press.

Law sheep. Law books are usually bound in sheep left wholly uncolored, hence the term. Many law books are now bound in buckram, canvas or duck.

Leatherette. Cloth or paper made to look like leather. There are many kinds used in binding, some of which look very well and wear about as long as poorer kinds of cloth.

Lettering block. A piece of wood of about the size and shape of a large book. Leather labels which are to be lettered in gold are laid on the rounded edge of this block that the pallet may be pressed on them more readily.

Lettering box. The iron box in which type are screwed up preparatory to lettering. To the box is attached a handle, the whole forming a pallet.

Lettering pallet. See Pallet.

Levant morocco. Originally made in the Levant from the skins of Angora goats. A superior quality of morocco, having a large and prominent grain. French levant morocco has long held its place as the best of all leathers for bookbinding.

Limp binding. Binding with a thin and yielding cover. A perfectly limp leather book can be rolled up easily.

Linen. See English linen.

Linen-finish buckram. Polished buckram and satin-finish book cloth. Manufactured by Jos. Bancroft & Sons Co., Rockford, near Wilmington, Del. (New York agent, Albert D. Smith, 35-37 Thomas St., New York.) The special features of these cloths, in which it is claimed they are superior, are uniformity of color, finish and fabric, wearing qualities, tensile strength, and easy application of decoration, ink or metal.

Lining papers. The colored or marbled paper at each end of a book. Called also End papers, which see.

Loose back. See Back, tight and loose.

Low buckram. See English linen.

Lying press. The term applied to the under side of the cutting press when used for backing. Usually called laying press.

Maioli style. A style prior to and contemporary with the early (Italian) examples of the Grolier. Generally composed of a framework of shields or medallions, with a design of scrollwork flowing

through it. Portions of the design are usually studded with gold dots. Ornaments are of moresque character.

Marbled calf. Calf so treated with acid that it bears some resemblance to marble.

Marbler. A workman who marbles the edges of the leaves.

Marbling. A process of decorating sheets of paper and edges of books with variegated colors in irregular patterns.

Millboard. The boards that are attached to the book to form the covers. Several kinds are in use now; the best is made of old naval cordage.

Millboard machine. See Board cutter.

Mitred. When the lines in finishing intersect each other at right angles and are continued without overrunning each other, they are said to be mitred.

Morocco. Leather made from goatskins, tanned with sumac, originally made in the Barbary states, but afterwards very largely in the Levant, and now produced in Europe and America from skins imported from Asia and Africa. The peculiar qualities of true morocco are great firmness of texture, with flexibility, and a grained surface, of which there are many varieties. This surface is produced by a process which consists largely in rolling and folding, called graining. True morocco is of extreme hardness, and makes the most durable book bindings; it is used also for upholstering seats and for similar purposes, and to a certain extent in shoemaking.

“Early specimens of red morocco, from the six-

teenth to the end of the eighteenth century, were found in good condition, and of all leathers noticed this seems to be the least affected. In the opinion of the committee, most of this leather has been tanned with sumac or some closely allied tanning material. Morocco bindings earlier than 1860 were generally found to be in fairly good condition; but morocco after that date seems to be much less reliable, and in many cases has become utterly rotten."—Report '01.

Leather called morocco, sometimes with a qualifying adjective, is now made in Europe and America. Much of this is very good, even when made, as it often is, from other skins than those of goats. Even the experts seem often unable to distinguish the good from the best. None of it is to be condemned or approved because it is or is not made in the Levant, or from goatskins.

Morocco. The name given to any imitation, often made of sheepskin, of the genuine morocco.

Morocco. For Bock, French, Levant, Persian, Turkey morocco, see the several words.

Morocco cloth. See Imperial morocco cloth.

Mosaic binding. A binding of leather decorated with designs made in whole or in part by inlaying pieces of leather or other material of different colors. The designs are usually outlined with gold.

Mottled calf. A light brown calf bookbinding, made to look mottled by treatment with acid.

Niger goatskin. Brought from Africa by the Royal Niger Company. A native production. It has a

very beautiful color and texture, with no grain. It has stood all the tests given it without serious deterioration. It does not keep clean under handling as well as a good coarse-grained morocco. Especially recommended by the committee appointed to investigate leather by the Society of Arts, of England.

Octavo. A sheet of paper folded into eight leaves, being, when folded, about $8\frac{1}{2} \times 5\frac{1}{2}$ inches; usually written 8vo.

Off-set. The impression made by print against the opposite page, when a book has been rolled or beaten before the ink is dried; also called Set-off.

Opened edges. See Edges opened.

Out of boards. When a volume is cut before the boards are affixed it is done "out of boards." Nearly all work is now done out of boards.

Overcasting. Sewing the leaves or signatures of a book together over and over. Usually done only when the book consists of single leaves or plates; but is quite commonly employed now in rebinding books, especially on the last two or three signatures front and back. Also called whip-stitching. Probably 90 per cent. of the books published today will stand wear better if they are properly overcast than if they are sewed in the ordinary way.

Pallet. Name given to the tool used in gilding upon the bands; sometimes applied to the steel box, with a handle, in which letters are fastened when they are pressed upon the back.

Panel. The space between bands; also applied to beveled and sunk sides.

Paneling. The sides of books are sometimes ornamented with sunken panels. Paneled covers



Lettering Pallet

are usually made of wood and covered with leather, though sometimes a paneled effect is produced on cardboards by heavy pressure.

Papering up. Covering the leaves of a volume to protect them while the volume is being finished. This is often done in fine binding, especially after edges have been gilded.

Paring. Reducing the edges of the leather by cutting them down to form a gradual slope. In large binderies now done by a machine.

Paring knife. The knife used for paring.

Pastewash. A thin dilution of paste in water.

Payne, Roger, style. The ornaments of this style are easily identified, being free and flowing in stem and flower; whereas before Payne's time they had been stiff and formal. The honeysuckle is a customary ornament. The impressions of the tools are usually studded round with gold dots, whether used in borders, corners, or centerpieces. The style is well suited for early nineteenth century literature, especially poetry.

Pebble grained. See Grain.

Persian morocco. A kind of morocco leather much used in bookbinding. It may be finished by graining in several styles. It is mostly made in Germany, from the skins of hairy sheep called Persian goats, whence its name is derived.

"East Indian or 'Persian' tanned sheep and goat-skins, called 'Persian morocco' or 'Persian sheep,' now used largely for cheap bookbinding purposes, are extremely bad. Books bound in these materials have been found to show decay in less than 12 months and probably no book bound in these leathers, exposed on a shelf to sunlight or gas fumes, can be expected to last more than five or six years."—Report '01.

Petits Fers. Small hand tools used in finishing, as distinguished from the stamps or blocks worked in a press.

Pieced. When the space between bands, where lettering or title is placed, has fastened to it a piece of leather different from the back, it is said to be pieced or titled.

Pigskin. Leather made of pigskin. It is very tough and if constantly handled wears well.

“Modern pigskin, if genuine, seems to last very well in some colors and in an undyed condition; but some colored pigskin bindings have utterly perished. Pigskin is naturally hard and rather stiff leather and is suitable for large books rather than small, and for books which are much handled.” “If submitted to severe softening processes in manufacture its durability is very small.”—Report '01.

Chivers has used a soft, thin pigskin with great success, here and in England.

Plate. An illustration printed from a plate. Term often incorrectly applied to illustrations printed from wood-cuts. Also, any full page illustration printed on paper different from that of the rest of the book is usually called a “plate.”

Plough. An instrument used in cutting the edges of books and boards.

Pointille style. The dotted style of ornament of Le Gascon.

Points. Small holes made in the sheets by the printer which serve as guides in registering and folding.



Flat Polisher

Polisher. A steel instrument for giving a gloss to leather after finishing.

Powder. See Seme.

Press. There are several kinds of presses, viz.: plough and press, for cutting, and standing, stamping, embossing, gilding, and finishing presses.

Press pin. An iron bar used for turning the screws of presses.

Pressing boards. Boards put between books when they are pressed. They are usually made of carefully seasoned wood, and have a heavy strip of brass about their edges, which projects a little above the board's surface. Books are laid on the boards with their backs projecting over this band enough to bring the latter exactly into the groove of the joint. Another board is laid on these books in the same position as the first, and so on. All are then pressed.

Pressing plates. Thin plates of metal, japanned or nicked, used to give a finish or polish to the leather on a book by placing them next to the leather and then subjecting book and plates to heavy pressure.

Publishers' bindings. See Case bindings.

Quarto. When a sheet is folded into four leaves, the size of the folded piece being about $11 \times 8\frac{1}{2}$ inches; usually written, 4to.

Quire. Twenty-four sheets. When the sheets of a pamphlet are folded and set into each other in one section, they are quired.

Recto. The right page; verso is the left page.

Red edges. See Edges red.

Register. When the print on one side of a leaf falls exactly over that on the other it is said to

register. Also, a ribbon placed in a book as a marker.

Renaissance ornaments. See Derome style.

Roan. Leather made of sheepskin and not split. See Sheepskin.

Rolled edges. See Edges rolled.

Rolling machine. A machine introduced to save the labor of beating. By it the sheets are passed between two revolving cylinders. Used in publishers' binding.

Rolls. Wheels of brass, cut to any pattern, for impressing gold leaf on leather.

Roulette border. A border design produced by a wheel on the circumference of which is engraved a pattern that reproduces itself as the wheel is revolved.

Rounded edges. See Edges rounded.

Rounding. The process by which the back of a book is made round.

Rounding hammer. A heavy, round-faced hammer used in rounding books.

Roundlet. A small circle in gold.

Roxburgh binding. A binding with a rather narrow leather back, without bands, simply lettered, paper sides and no leather corners.

Rubbing or rub-off. The name usually given to the copy of the lettering on the back of the book,



Rounding Hammer.

made by holding thin paper tightly over the back and rubbing the paper with a heel-ball or a piece of plumbago.

Run up. When a back has a fillet run from top to bottom without being mitred at each band, it is said to be run up.

Russia leather. A fine leather prepared in Russia, and imitated elsewhere, by very careful willowbark tanning, dyeing with sandalwood, and soaking in birch oil. It is of a brownish red color, and has a peculiar and characteristic odor. The genuine is not often used in binding; it is not as strong as cowhide.

“In nearly all samples of Russia leather a very violent form of red decay was noticed. In many cases the leather was found to be absolutely rotten in all parts exposed to light and air, so that on the very slightest rubbing with a blunt instrument the leather fell into fine dust.”—Report '01.

Saddle-stitched. A pamphlet or book of one signature only sewed with thread or fastened with wire staples along the back is said to be saddle-stitched.

Sawing in. Making grooves in the back of a book with a saw to receive strings or bands.

Seal grain. See Grain.

Section. A folded sheet. See Signature.

Seme, or Semis, or Powder. Ornamentation in which a device is repeated at regular intervals.

Set-off. See Off-set.

Setting the head. Covering the headband neatly with the leather to form over it a kind of cap.

Sewer. The person who sews together on a sewing bench the sheets, called when folded sections or signatures, to form a book.

Sewing bench. A board from one side of which rise two sticks across which is a bar, which can be moved up and down and fixed in any desired posi-

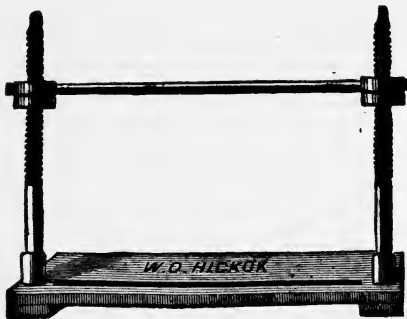

Sewing Bench

tion. Strings, bands, or tapes are stretched vertically between the edge of the board and the cross bar; against these the signatures of a book are successively placed and to them sewed.

Sheepskin. The commonest leather used for binding. When unsplit it is called Roan. When split in two, the upper half is called Skiver, the under or fleshy half a Flesher. This leather is easy to work, takes gold lettering easily, and looks fairly well on a book. But it is not strong, and most kinds dry out and break within three to five years, even if much handled. The leather made from the skin of the sheep is not all alike. The remark already

made, that a given piece of leather is not to be condemned for its name, applies to all the other leathers in this list. The skin from some mountain-bred sheep, for example, if well tanned, makes a good leather.

“Sheepskin bindings of the early part of the century are many of them still in good condition. Sheepskin, in a fairly natural state, seems to keep its flexibility, but it is very easily damaged by friction. Since about 1860 sheepskin as sheepskin is hardly to be found. We have instead sheepskins grained in imitation of various other leathers, and these imitation grained leathers are, generally speaking, in a worse condition than any others, excepting, perhaps, some of the very thin calf bindings.”—Report '01.

Shelf-back. The back of the book, showing the title, bands, decorations, etc.

Signature. The letter or figure under the foot-line of the first page of each sheet or signature to indicate the order of its arrangement in the book; often applied to the sheet itself.

Sixteenmo. A sheet folded into sixteen leaves, about 4x6 inches when folded. Usually written 16mo.

Size. A preparation of pastewash used in finishing and gilding.

Sizes of books. See folio, quarto, octavo, etc.

Skiver. The outer hair or grain side of sheepskin which has been split. It is commonly the thinner of the two parts, as when the inner is prepared for chamois. It usually looks well, and is

easily worked, but is not strong. Much used for bindings. See Sheepskin.

Slips. The ends of the band, twine or tape on which the book is sewn that project beyond the back after it is sewed.

Smooth calf. Plain or undecorated calf.

Split leather. Leather split by machine. Two or more pieces or splits are thus obtained either of which may be used. The inner layer is usually of inferior quality. Sometimes leather is split simply to secure uniformity of thickness in the outer parts.

Sprinkled calf. Calf so treated with acid that it looks as if it had been sprinkled with a dye.

Sprinkled edges. Cut edges of books sprinkled with color, that the marks made by handling may be less evident.

Squares. The portion of the boards that project beyond the edge of the leaves of the book.

Stabbed. A pamphlet or book of one or more signatures held together by thread or wire staples driven vertically through near the back edge is said to be stabbed.

Stabbing. The operation of piercing the boards with a bodkin for the slips to pass through. Also the piercing of pamphlets for stitching. Also the process of fastening pamphlets together with staples of fine wire, done on a machine.

Stamping press. See Blocking press.

Stamps. The brass tools used in finishing to impress figures upon the leather; they are distinguished as hand stamps and stamps for the press.

Standing press. A large press with screw for pressing many books at once.

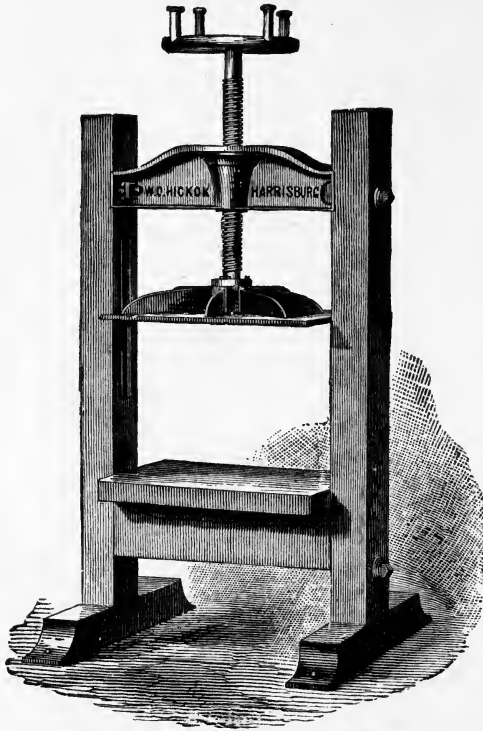

Standing Press of Wood and Iron

Start. When, after cutting, one or more sections of the book come forward, making the fore edge irregular, they are said to have started.

Steamboating. Cutting books out of boards, a number being cut at the same time.

Straight edge. A flat ruler.

Super. A thin, loosely woven cotton cloth, glued onto the backs of books to help to hold the signatures together and, by extending over to the inside of the cover, to hold book and cover together. In publishers' binding this is usually all that holds a book in its case. It is thin and loosely woven that it may be easily glued down and starched that it may be easily handled. Its place is taken in good binding by fine muslin or jaconet.

T. E. G. Top-edge gilt.

Tacky. Sticky; spoken often of glue after it has set, but before it is quite dry.

Tail. See Head and tail.

Tape. Cotton tape on which many books are best sewn. It should be stout but flexible.

Thread. The thread with which books are sewn is usually made of linen, unbleached. It comes in several sizes. If of good quality, say Hayes's Standard linen, it costs about \$1.25 per pound for No. 18 2-cord.

Silk thread is sometimes used in extra binding and on very thick books.

In machine sewing cotton thread is used and wears well.

Thirty-twomo. A sheet of paper folded into thirty-two leaves; usually written 32mo.

Three-quarters bound. See Half-bound.

Tight back. See Back, tight and loose.

Title. The space between the bands upon which the title is lettered.

Titled. See Pieced.

Tools. Brass stamps used for impressing gold leaf on leather. Applied particularly to the hand stamps and tools used in finishing.

Top cover. The upper or front cover of a book in binding.

Top edges. The head or top of a book, in contradistinction to fore-edge or tail.

Top gilt. Used in speaking of a book of which the top edge only is gilded.

Top side. The front side of the cover of a book in binding.

Tree calf. A bright brown calf stained by acids in conventional imitation of the trunk and branches of a tree.

Trimmed. The edges of a book are said to be trimmed when the edges of the larger or projecting leaves only have been cut.

Trindle. A strip of thin wood or iron used to take the round out of a book when it is cut.

Tub. The stand which supports the lying press. Originally an actual tub to catch the shavings.

Turkey morocco. Made of goatskins from Turkey. It is very strong, durable leather; expensive, but worth the money.

Turning up. The process of taking the round out of a book when the edge is cut. All books that are cut in boards have a pair of trindles thrust between the boards and across the back to assist in this operation.

Tying up. Tying a volume with heavy twine after the leather cover has been drawn on to make the leather adhere to the sides of the bands; also to help in setting the head.

Uncut. A book is said to be uncut when the edges of the paper have not been cut with the cutting machine.

Unopened. A book is said to be unopened if the bolts of the sheets have not been cut.

Vellum. See Art vellum.

Verso. The left page.

Waste, or Waste leaves. Part of the end papers and the blank leaves between the colored end papers and the book proper; should be part of the same lot of paper with which the book is printed. One of the waste leaves is often pasted to the loose half of the lining paper or end sheet, thus forming a doubled fly-leaf.

Waste papers. See End papers.

Waterproof sheets. Sheets of celluloid or waterproof cardboard sometimes laid in or between books when pressing.

Whatman paper. A high grade quality of English hand-made paper, both laid and wove, chiefly used for drawing.

Whipping. Same as whipstitching or overcasting.

Whipstitching. See Overcasting.

White edges. Simply cut, without being gilded or colored.

Whole binding. When the leather covers the back and sides of a volume.

Wire staples. Fine wire staples used by certain book-sewing machines in the place of thread for holding the sections to a piece of muslin. Also the staples used in place of thread in saddle-stitching a pamphlet of one signature on a machine. Used also in holding a book of several signatures together, the staple being driven through all the signatures close to their back edges.

Witness. When a book has been trimmed, leaving some of the leaves still rough, the latter are a witness as to the original size of the sheet and prove that it has not been cut down.

Wove paper. That which does not show water-marked lines running across it; distinguished from laid paper.

CHAPTER XIX

Makers and Dealers in Bookbinders' Materials, Tools and Machinery

Jos. Bancroft & Sons, manufacturers, Rockford, Wilmington, Del. Book cloths. Albert D. Smith, 35 and 37 Thomas St., New York, New York agent.

John Campbell & Co., 34 Ferry St., New York. Leathers, book cloths, marble papers, etc.

Cedric Chivers, 911 Atlantic Ave., Brooklyn, N. Y., and Bath, England. Binder from publishers' sheets, rebinder, art binder.

Crawley Book Machinery Company, Newport, Ky. Bookbinders' machinery.

Louis De Jonge & Co., 71-73 Duane St., New York. Leather, book cloths, fancy paper, bookbinders' supplies and machinery.

Dennison's Manufacturing Co., 15 John St., New York. Gummed labels and other office supplies.

Miss Edith Diehl, 131 E. 31st St., New York. Leather and binding supplies.

Gane Bros., 81 Duane St., New York. Leathers, cloths, boards, bookbinders' supplies and machinery of every description.

Thos. Garner & Co., 181 William St., and 22 Spruce St., New York. Manufacturers of leathers and bookbinders' supplies.

Gaylord Bros., 117 Emerson Building, Syracuse, N. Y. Book repair material of many kinds.

The H. Griffin & Sons Company, 75-77 Duane St., New York. Leathers, book cloths, marble papers and bookbinders' materials of every description.

The Hamilton Manufacturing Company, main office and factory, Two Rivers, Wis.; eastern office and warehouse, Middletown, N. Y. Bookbinders' furniture and supplies.

C. B. Hewitt & Brothers, 48 Beekman St., New York. Paper, boards and glue.

The W. O. Hickok Manufacturing Co., Harrisburg, Pa. Bookbinders' machinery.

Holliston Mills, Norwood, Mass., and 67 Fifth Ave., New York. Book cloths.

Hoole Machine and Engraving Works, 29 Prospect St., Brooklyn, N. Y. Manufacturers of bookbinders' tools and machinery.

Interlaken Mills, 111 Duane St., New York. Book cloths.

Japan Paper Co., 34 Union Square, E., New York. Hand-made Japanese window or Shoji paper for repairing leaves, also called Japanese mending tissue.

Keratol Company, corner South and Van Buren Sts., Newark, N. J. Manufacturers of imitation leathers.

Latham Machinery Company, 197-201 S. Canal St., Chicago, Ill. Manufacturers of bookbinders' and printers' machinery.

Lindenmeyr & Sons, 20 Beekman St., New York. Paper.

J. W. O'Bannon Company, 74 Duane St., New York. Dealers in all bookbinders' supplies.

Oswego Machine Works, Oswego, N. Y. Bookbinders' machinery.

C. & W. Pyle Company, 4th and Van Buren Sts., Wilmington, Del. Bookbinders' material.

Schulte & Co., 51 N. 7th St., Philadelphia, Pa. Leather and book cloths.

T. W. & C. B. Sheridan, 56 Duane St., New York. Bookbinders' machinery.

J. L. Shoemaker & Co., 15th and S. 6th Sts., Philadelphia, Pa. Machinery, paper, leather, etc.

Standard Machine Co., Mystic, Conn. Bookbinders' machinery.

Stark & Selig, 458 W. Broadway, New York. Book stamps and embossing dies.

F. Wesel Manufacturing Company, 10 Spruce St., New York. Bookbinders' machinery.

CHAPTER XX

A Few of the Best Books on Bookbinding, Paper and Leather

Those marked (S) will be found the most useful books for a small library.

Adam, Paul. Practical bookbinding. Van Nostrand. New York. 1903. \$1.25. This is a translation from the German, the author being the director of the Düsseldorf Technical School of Artistic and Practical Bookbinding. It treats mainly of the practical side of binding and describes with considerable detail the materials used in the work. It is illustrated mostly with outline cuts which aid the reader or student to understand the several methods and processes.

Brassington, W. S. History of the art of bookbinding. Stock. London. 1894. \$10.00. Interesting illustrations of ancient records before book making. Notices of printers, collectors, binders and famous books. Appendix C gives samples and brief descriptions of oriental forms of binding. Very good general work.

Butler, J. W. The story of paper making. Butler Paper Co. Chicago. 1901. \$1.25. An interesting account of paper making from its earliest known record down to the present time.

(S) Chivers, Cedric. Improvements in the binding of books. Cedric Chivers. Bath, England. Free. Description of the methods used by Chivers in his own bindery. The writer has a high reputation, and probably binds books more satisfactorily for libraries than any binder in the world today.

(S) Cockerell, Douglas. Bookbinding and the care of books. Appleton. New York. 1902. \$1.25 net. Text-

book of workshop practice from personal experience and critical examination of methods current in shops. It supplements workshop training and is a help in the selection of sound bindings. The best single book for the librarian who wishes to know about the craft of binding. Does not treat the subject of strong rebinding for the public library.

Cockerell, Douglas. A note on bookbinding . . . with extracts from the special report of the Society of Arts on leather for bookbinding. London. Issued by W. H. Smith & Son, for their bookbinding department. 1904. Price 1 penny.

7 Crane, W. J. E. Bookbinding for amateurs. L. Upcott Gill, London, no date. Price \$0.65. This gives a description of the various tools and appliances required and minute instruction for their use.

Cundall, Joseph, ed. On bookbindings ancient and modern. Bell, London, 1881. Price \$12.00. An excellent history of the art from earliest times. Contains a chronological list or table of famous bookbinders, with their nationalities, dates of birth and death.

Fletcher, W. Y., F. S. A. Bookbinding in France. Macmillan & Co., New York, 1894. \$0.75. An accurate brief account of the history and growth of the art in France. Profusely illustrated, with cuts in the text and with facsimiles in color.

(S) Gane Brothers. Bookbinders' stock. Free. Gane. 81 Duane St., New York. A trade catalogue, giving cuts of articles as well as prices.

Growoll, A. The profession of bookselling. 2v. Publisher's Weekly. New York. 1895. \$4.00 net. Contains an excellent article on bookbinding with descriptions of leather and other cover material, cost and other details. A list of authorities is given and a description of technical terms.

Hasluck, Paul N., ed. Bookbinding. David McKay, Philadelphia, 1903. \$0.50. A practical text-book with numerous engravings and diagrams.

Horne, Herbert P. The binding of books. Scribner, New York, 1894. \$2.00. Shows how good decoration on bindings can be made only by those who understand design.

(S) Hulme, Parker and others. Leather for libraries. Published for the Sound leather committee of the Library Association, England, by the Library Supply Company. London. 1905. Price \$0.40. A summary of the report of the committee of the Society of Arts, brought down to date, and with helpful notes added. Includes small samples of leather.

Journal of the Society of Arts. 4 nos. 20 cents each. London. Sept. 11, 18, 25, Oct. 2, 1903. Four lectures delivered by Julius Hübner, director of the paper making department, at the Municipal School of Technology, Manchester, England, giving a practical treatise on paper making. Also issued as "Cantor Lectures" in one pamphlet, same society. 25 cents.

Journal of the Society of Arts. 20 cents. London. July 5, 1901. Report of a committee on leather for bookbinding. The decay of leather, a subject which has attracted a great deal of attention and interest among librarians and collectors. The best thing for librarians ever published on leather.

Matthews, Brander. Bookbinding, old and new. Macmillan, New York, 1895. \$3.00. Notes of a book-lover, with an account of the Grolier Club of New York.

Nicholson, James B. Manual of the art of bookbinding. Baird, Philadelphia, 1856. \$1.00. Instructions in the different branches of forwarding, gilding, finishing and marbling.

(S) Pearce, W. B. Practical bookbinding. Marshall & Co., London, no date. 25 cents. A text-book designed to give sufficient help to enable handy persons to bind their own books. Illustrated with photographs and drawings.

Prideaux, S. T. An historical sketch of bookbinding. Lawrence. London. 1893. \$1.50 net. Intended as a help in the first steps. A chronological table of French and

English sovereigns is added with a bibliography and explanation of technical terms. An appendix treats of ornamentation.

Public Libraries, June, 1904. Binding number.

Public Libraries, June, 1906. Binding number.

Report of the committee on leather for bookbinding. Edited by Cobham and Wood for the Society of Arts. London. Bell. 1905. \$2.80. Contains some material on dyeing leather not in the original report; has numerous illustrations, 12 samples of leather, well printed, bound in cloth.

Society of Arts—Committee on the deterioration of paper. Report . . . with two appendixes: 1, abstracts of paper on German official tests, 1885-96; 2, correspondence. London. 1898. 25 cents.

Zaehnsdorf, J. W. The art of bookbinding. \$1.25. Bell. London. 1880. \$1.25. Step by step an imaginary book is bound, as in an "extra shop," to show the amateur how to bind his own book or how to know a good binding when purchasing. Illustrations of machinery used are given and practical receipts.

Zahn, Otto. On art binding. S. C. Toof & Co., Memphis, 1904. \$1.50. Illustrated with half-tone pictures of fine bindings by the author.

Index

- Acids used in dyeing, Effects
of, 76, 95
Aldine style, 119
All-along sewing, 119
American Russia leather, 154
Antique, 124
Arabesque style, 119
Art canvas, 41, 119
Art vellum, 120
Azure tools, 120
Azured style, 121
- Backing, 33, 121
Backing boards, 121
Backing hammer, 122
Backing machine, 122
Backing press, 122
Backs, 121
Backs, loose, repairing, 81
Backs, material for, 41
Band driver, 122
Band nippers, 122
Bands, 122
Bead, 123
Beating hammer, 124
Beating stone, 124
Beveled boards, 124
Bibliography of bookbinding,
165
Binder, 124
Binder's workshop in 1771, vi
Binders for magazines, 61
Bindery, equipment, 114
Binding, flexible, 135
Binding from publishers'
sheets, 20
Binding materials for backs,
41
- Binding materials for sides,
42
Binding, mosaic, 147
Binding records, 110
Bindings, broken, 124
Bindings, broken, mending, 80
Bleed, 124
Blind tooling, 124
Blocking press, 125
Board papers, 125
Board shears, 125
Boards, 47, 125
Boards, binding in, 142
Boards, broken, repairing, 84
Boards, pressing, 152
Bock morocco, 126
Bodkin, 126
Bolt, 126
Book covers, machine-made,
26
Book list on bookbinding,
165
Bookbinding terms, 119
Bosses, 126
Boston binder, 65
Broken bindings, mending,
80
Broken boards, replacing, 84
Brushes, 86
Buchan binder, 66
Buckram, 126
Buckram, Linen finish, 145
Buffing, 126
Buffingette, *see* Keratol, 143
Bureau of standards, speci-
fications for book cloth, 43
Burnishers, 127
Burnishing, 126

- Calf lined, 127
 Calf, marbled, 146
 Calf, sprinkled, 157
 Calf, Tree-, 160
 Calfskin, 127
 Cancels, 127
 Canvas, 132
 Caps, 127
 Case bindings, 128
 Catchword, 128
 Center tools, 128
 Chivers binder, 66
 Circuit edges, 128
 Clasp, 128
 Cleaning books, 74
 Clearing out, 128
 Cleveland binder, 62, 67
 Clip binders, 63
 Cloth, 86
 Cloth boards, 128
 Cloth, English Imperial Morocco, 41, 141
 Cloth, standards, 43
 Cobden-Sanderson style, 128
 Collating, 128
 Combs, 129
 Copying press, 87
 Corners, 129
 Cost of binding, 20
 Covering (repairing), 82
 Covers, loose, reattaching, 82
 Cowhide, 129
 Cowskin, 41
 Creaser, 129
 Cropped binding, 129
 Crushed leather, 129
 Crushed levant, 129
 Cut flush, 130
 Cutter, 130
 Cutting boards, 87, 130
 Cutting machine, 130
 Cutting press, 130

 Dandy, 130
 Dealers in bookbinding materials, 163

 Decay of leather, 76, 95
 Deckle edge, 131
 Dentelle border, 131
 Derome style, 132
 Diaper, 132
 Divinity calf, 132
 Doublure, 132
 Duck, 132
 Dutch metal, 133

 Eau de Javelle, 142
 Edges, Gaufre, 138
 Edges, gilt, 138
 Edges, soiled, cleaning, 83
 Edges, treatments in binding, 133
 Edition de luxe, 133
 Embossed, 133
 End leaves, 133
 End papers, 134
 End papers, renewal, 80
 End sheets, 45
 English linen, 134
 Eve style, 134
 Extra binding, 134

 Fanfare style, 134
 Fillet, 135
 Finishing, 135
 Finishing press, 135
 Finishing stove, 135
 Flexible binding, 135
 Flexible glue, 135
 Flexible sewing, 137
 Fly leaves, 137
 Fly leaves, removal, 80
 Folder, 87, 137
 Folio, 137
 Fore-edge, 137
 Fore-edges, cutting, 83
 Forwarding, 137
 French guard, 137
 French joint, 34, 50, 137
 French morocco, 137
 Full bound, 138

- Gascon style, Le, 138
 Gathering, 138
 Gaufre edges, 138
 Gauge, 138
 Gilding, 53
 Gilding press, 138
 Gilt, 138
 Gilt edges, 138
 Gilt tops, 138
 Glair, 138
 Glue, 47
 Glue, flexible, 135
 Glue pot, 87
 Goatskin, Niger, 147
 Goffered edges, 139
 Gold cushion, 139
 Gold knife, 139
 Gold leaf, 139
 Gouge, 139
 Grain (leather), 139
 Graining, 139
 Grater, 139
 Grease marks, removal, 85
 Grolier style, 139
 Groove, 140
 Ground glue, 87
 Guard, French, 137
 Guards, 140
 Guards for plates, 48
 Guides, 140
 Guillotine, 140
 Gummed paper, 87
 Half-bound, 140
 Half-title, 141
 Hand letters, 141
 Hand-sewing, 45
 Head and tail, 141
 Head cap, 141
 Heel-ball, 141
 Imperial morocco cloth, 141
 Ink stains, removal, 84
 Inset, 142
 Inside margins, 142
 Inside tins, 142
 Italian style, 119
 Jansen style, 142
 Japanese mending paper, 87
 Japanese mending tissue, 52
 Javelle water, 142
 Johnston binder, 65
 Joint, French, 137
 Joints, 142
 Joints, repairing, 81
 Justification, 143
 Keratol, 143
 Kettlestitch, 143
 Keys, 143
 Kip calf, 144
 Klip binder, 67
 Knife, 87
 Knocking-down iron, 144
 Labels, 57
 Labels, renewal, 77
 Laced in, 144
 Laid paper, 144
 Law sheep, 144
 Leather, 93
 Leather, decay, 76, 95
 Leather, grain in, 139
 Leather, Russia, 154
 Leather, treatment with oil,
 76
 Leatherette, 144
 Le Gascon style, 138
 Lettering, 47, 53
 Lettering block, 144
 Lettering box, 144
 Lettering pallet, 148
 Lettering by hand, 55
 Lettering in white ink, 56
 Levant morocco, 145
 Library binding, 17 and foll.
 Life histories of library bind-
 ings, 22
 Limp binding, 145
 Linen, English, 134
 Linen-finish buckram, 145
 Lining papers, 133, 145
 Loose backs, repairing, 81

- Loose joints, repairing, 81
 Loose leaves, inserting, 78
 Low bruckram, 134
 Lying press, 145
- Magazine binders, 61
 Magazines, binding single
 copies, 64
 Maioli style, 145
 Maps, mounting, 52
 Maps, repairing, 84
 Marbled calf, 146
 Marbler, 146
 Marbling, 146
 Margins, 142
 Marking books, 57
 Mending books, 68
 Mending tissue, 87
 Millboard, 146
 Mitred, 146
 Morocco, 41, 146
 Morocco, French, 137
 Morocco, Levant, 145
 Morocco, Persian, 150
 Morocco, Turkey, 160
 Morocco cloth, 41, 147
 Morocco cloth, Imperial, 141
 Mosaic binding, 147
 Mottled calf, 147
 Mounting, 52
 Music, binding, 50
- Needles, 87
 Newark library, binding rec-
 ords, 112
 Newark library, binding sta-
 tistics, 22
 Newark library, repairing
 methods, 74
 New Haven binder, 65
 Newspapers, binding accord-
 ing to use, 42
 Niger goatskin, 147
 Numbering backs, 53
- Octavo, 148
 Off-set, 148
- Opening, ease of, 23
 Out of boards, 148
 Overcasting, 46, 148
- Pallet, 148
 Pamphlets, binding, 58
 Panel, 148
 Paneling, 149
 Paper, 101
 Paper, determining quality,
 109
 Paper, mending, 88
 Paper, laid, 144
 Paper, qualities, 106
 Paper covers, 90
 Paper used in books, 106
 Papering up, 149
 Paring, 149
 Paring knife, 149
 Paste, 85, 88
 Pastewash, 150
 Payne, Roger, style, 150
 Pencil marks removed, 74
 Persian morocco, 150
 Petits fers, 150
 Philadelphia binder, 67
 Pieced space, 150
 Pigskin, 41, 151
 Plane, 151
 Plates, broken-up, 126
 Plates, insertion on guards,
 48
 Plates, pressing, 152
 Plough, 151
 Pointille style, 151
 Points, 151
 Polishers, 151
 Powder, 154
 Press, 152
 Press pin, 152
 Pressing boards, 152
 Pressing plates, 152
 Publishers' bindings, clean-
 ing, 75
 Publishers' bindings, stat-
 istics of wear, 20

- Quarto, 152
 Quire, 152

 Rag paper, 102
 Rebinding, cost of, 20
 Rebinding for wear, 36
 Rebinding, preparation of
 books for, 44
 Records of binding, 110
 Recto, 152
 Register, 152
 Repairing books, 68
 Repairing joints, 71
 Re-siding books, 83
 Roan, 153
 Roedde magazine binder, 66
 Roger Payne style, 150
 Rolling machine, 153
 Rolls, 153
 Roulette border, 153
 Rounding, 153
 Rounding hammer, 153
 Roundlet, 153
 Roxburgh binding, 153
 Rubbing, 153
 Rugby wrapping paper for
 covers, 91
 Ruler, 88
 Run up, 154
 Russia leather, 154

 Saddle-stitched, 154
 Sawing in, 154
 Scissors, 88
 Seme, 154
 Setting the head, 154
 Sewer, 155
 Sewing all along, 119
 Sewing by hand, 27
 Sewing in loose sections, 79
 Sewing, flexible, 137
 Sewing bench, 88
 Sheep, Law, 144
 Sheepskin, 155
 Shelf-back, 156
 Sides, material for, 42

 Signature, 156
 Sixteenmo, 156
 Size, 156
 Skiver, 156
 Slips, 157
 Split leather, 157
 Springfield binder, 66
 Sprinkled calf, 157
 Sprinkled edges, 157
 Squares, 157
 Stabbed, 157
 Stabbing, 157
 Stabbing awl, 126
 Stains, removal, 85
 Stamps, 157
 Standing press, 158
 Start, 158
 Steamboating, 159
 Stitching, 154
 Straight edge, 159
 Style, Grolier, 139
 Style, Le Gascon, 138
 Style, Pointille, 151
 Style, Roger Payne, 150
 Style, Roxburgh, 153
 Super, 159

 Tacky, 159
 Tape, 159
 Thirty-two-mo, 159
 Tapes, sewing on, 32
 Terminology of bookbinding,
 119
 Thread, 45, 89, 159
 Tins, Inside, 142
 Tipping-in, 71
 Title, 160
 Tools, 160
 Top cover, 160
 Top edges, 160
 Top gilt, 160
 Top side, 160
 Tops, gilt, 138
 Torn leaves, mending, 75
 Torsion binder, 66
 Tree calf, 160

- Trimming, 160
Trindle, 160
Tub, 160
Turkey morocco, 160
Turning-up, 160
Tying-up, 161
- Uncut, 161
Unopened, 161
- Waste leaves, 161
Waterproof sheets, 161
- Wearing qualities of leather,
95
Weis binder, 66
Whatman paper, 161
Whipping, 161
Whipstitching, 45
White edges, 161
White ink, 56
Whole binding, 161
Wire staples, 162
Witness, 162
Wood paper, 101
Wove paper, 162







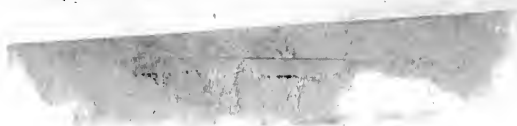

202024

UNIVERSITY OF CALIFORNIA LIBRARY

