

Micro. info.
UCLC: 5248064

A
0005501580
UC SOUTHERN REGIONAL LIBRARY FACILITY

CONFIDENTIAL!
FOR OFFICIAL USE ONLY

NOT TO BE TAKEN INTO FRONT LINE TRENCHES

NOTES ON RECENT OPERATIONS

No. 2

EDITED AT THE ARMY WAR COLLEGE
FROM FRENCH AND BRITISH SOURCES

Spencer

JULY, 1917

UNIVERSITY OF CALIFORNIA
AT LOS ANGELES

MAR 28 1934
LIBRARY



WASHINGTON
GOVERNMENT PRINTING OFFICE
1917

WAR DEPARTMENT

Document No. 641

Office of The Adjutant General

WAR DEPARTMENT,

WASHINGTON, *August 1, 1917.*

The following Notes on Recent Operations, No. 2, is published for the information of all concerned.

(300.6, A. G. O.)

BY ORDER OF THE SECRETARY OF WAR:

TASKER H. BLISS,

Major General, Acting Chief of Staff.

OFFICIAL:

H. P. McCAIN,

The Adjutant General.

(3)

WAR DEPARTMENT,
THE ADJUTANT GENERAL'S OFFICE,
Washington, June 19, 1917.

To all officers of the Army:

You are advised that this and all subsequent documents of a similar character which may be furnished to you from this office are to be regarded as strictly confidential. They are to be kept at all times in your personal possession, and are not to be copied, nor are any parts of their contents to be communicated either directly or indirectly to the press, nor to any persons not in the military or naval service of the United States. In Europe these documents are not to be carried into the front-line trenches, nor farther to the front than the usual post of the officers to whom issued.

Strict compliance with this injunction is enjoined upon every officer into whose hands any of these confidential documents may come.

By order of the Secretary of War:

H. P. McCain,
The Adjutant General.

(4)

TABLE OF CONTENTS.

	Page.
1. Notes on fortification shelters in the position warfare of the present time.....	7
2. German land mines.....	11
3. Combat in woods.....	22
4. Mont Cornillet Tunnel.....	25
5. Tactical principles in defensive combat, position warfare..	27
6. Methods of German infantry attack.....	33
7. German charged entanglements.....	38
8. Bicycle units.....	40
9. German methods in establishing lines of defense.....	44
10. New organization of the German infantry company.....	45
11. Notes on the field recruiting depot.....	47
12. The light machine guns recently put into service in the German infantry.....	49
13. German helmet for lookouts.....	50
14. Notes on light infantry trench mortars and machine guns..	51

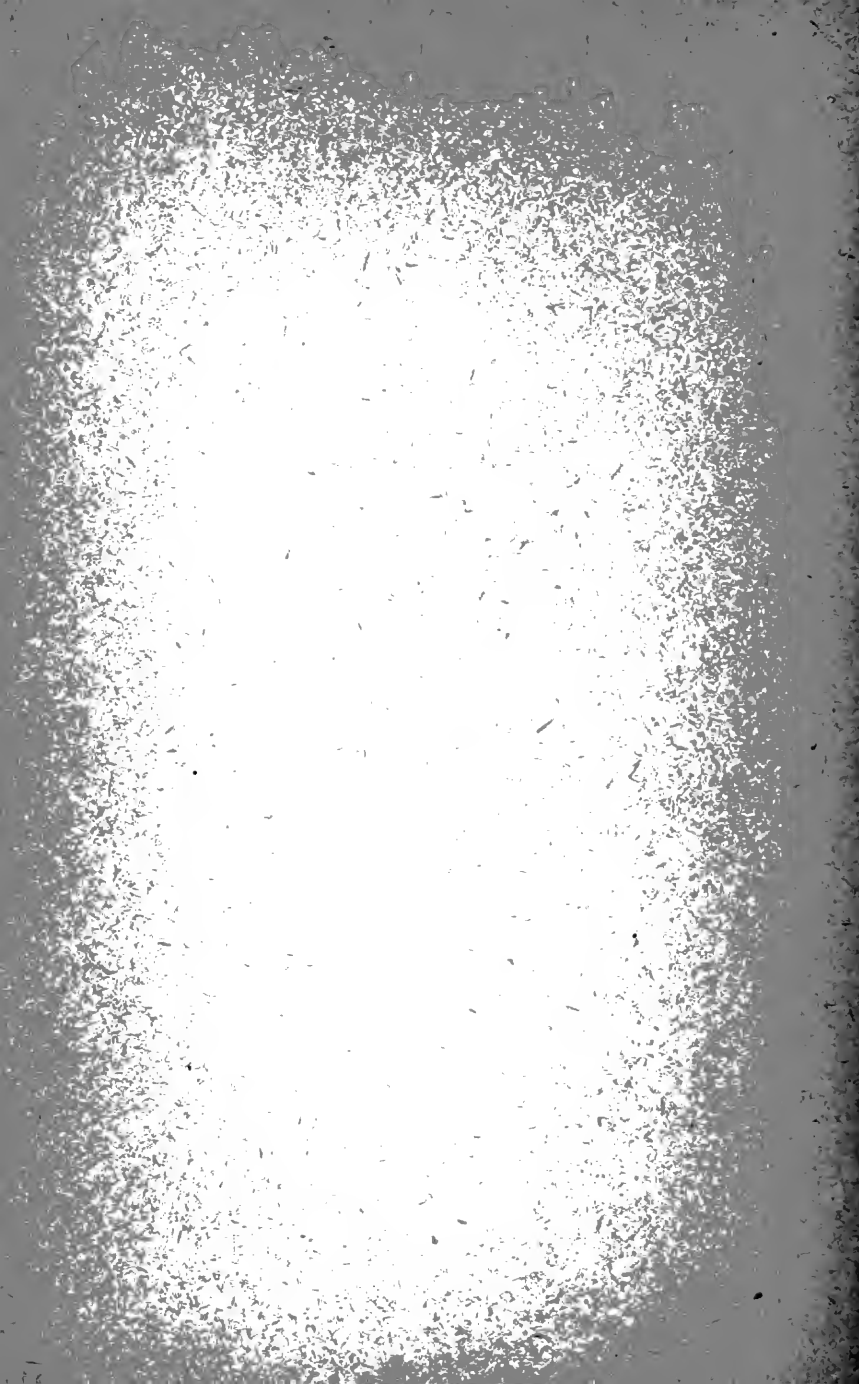

NOTES ON FORTIFICATION SHELTERS IN THE POSITION WARFARE OF THE PRESENT TIME.

(WRITTEN BY A FRENCH GENERAL STAFF OFFICER, JULY 12, 1917.)

To assist in the study of "Instruction in Field Works" of December 21, 1915.

1. The first duty of a commander is to reduce losses as much as possible. It is therefore necessary to construct numerous and highly resistive shelters.

On the other hand, it is necessary that a body of troops be always ready to repel an attack, and not be surprised in its bombardment shelters. Hence, the depth of the shelters, and consequently their resisting strength, depends on the position they occupy in the defensive organization. The light shelters are generally improvised in the advance lines. The bombproofs are systematically constructed farther back.

2. *Light shelters.*—The first position comprises a series of successive lines formed in depth. Except at certain points peculiarly important, as, for example, the observing stations, it is conceded that the first line is one of advance posts, occupied only by lookouts. Indeed, in the actual procedure of attack (in force or by surprise) the attacker is always certain of penetrating the first hostile line. Furnishing it with defenders consequently allows the enemy to take prisoners easily, which is often the object of local attacks. In case of a local attack, the first line is evacuated almost completely, and the enemy is ousted by an immediate counter attack. In case of a general attack, some sacrifices in men are made to hold the first position. Hence, as a general rule, shelters are useless and even dangerous in the line of lookouts, since they tempt the lookouts to take refuge in them under bombardment, and consequently to neglect their duty.

To the rear of the line of lookouts is the real line of resistance, that which should be occupied in case of attack. In ordinary times the garrison of this line occupies shelters located to the rear—e. g., on a line with the lateral communication trench, if there is one, and connected with the line by numerous and easily accessible communication trenches.

The model of these shelters is usually that of the dugout shelter under a parapet (fig. 76 of the instruction of the field works), proof against "105's" or "150's."

They should have numerous exits and the criterion of good arrangement of these shelters is the speed with which the garrison can be brought out to man the firing parapet. Means of protection should be taken against gas (wet cloths to close the shelters, etc.).

Care must be taken to have a shelter lookout always at one of the entrances to give the alarm in case of attack. This is a general rule for all troops under shelter. In most cases sufficient protection is secured by simple trenches, which are narrow and deep. They can be used when it is desired to mass troops close to the advance line in expectation of an attack. They are then called "places of arms."

A small safety garrison is usually left in the trench itself. This garrison can protect itself from shrapnel by one of the methods indicated in figures 60, 61, 62 of the same instructions.

Niches in the walls endanger the solidity of the parapet if the earth is not very consistent. Covered trenches prevent the combatants from going over the parapet, and create, if used on a wide front, a dangerous trap.

Behind the line of resistance is the line of supports. On the level of the line of supports the local reserves are held. These reserves are charged with reenforcing the garrison of the line of resistance, or with making a counter attack to recapture this line if it has been pierced at any point.

The works in which these reserves are held usually come under the second category mentioned in paragraph 1 (bomb proofs systematically constructed, which we will meet with again in the second positions and the positions in the rear).

3. *Bomb-proof shelters.*—The form of these works depends on the terrain. It is essential to provide against inundations of water. Whenever the nature of the soil, the slope, or facilities for drainage allow, the mine gallery shelter is preferable, as it is the most solid, the least visible, and the most quickly built.

In France, special battalions, called M. D. battalions (Mascart Desolliers), construct this kind of work very rapidly with the help of improved matériel.

If it is necessary to establish shelters above the ground, one should use layers of logs, reenforced by bursting layers or slabs of cement. One must remember that in this type (fig. 73) the sides are as vulnerable as the roof, and must be protected in the same way. Actually, the only shelter above ground that provides an absolute protection

is the one strengthened with concrete (fig. 91), but, because of the slowness and cost of the work, it should generally be reserved for the important parts of the defense (command posts, machine gun blockhouses, observing stations, telephonic centers, etc.).

(a) Important command posts include a sufficiently large number of different apartments to be able to billet all additional personnel—artillery commander, liaison agents, telegraphists, signalers, etc.

They are usually of the mine gallery type (M. D.). It is important to place them in the neighborhood of an observing station and a communication route, while avoiding locating them in villages, which are points highly conspicuous for the enemy's artillery.

(b) The machine guns are placed in concrete casemates or in the open. They are placed in concrete casemates when they are to fill a peculiarly important checking mission in a given direction (enfilade fire into a ravine, flanking fire on an obstacle, etc.). In this case the machine gun shoots through an embrasure and the casemate includes room for the gunners. The machine guns are usually found in casemates in the lines of supports of the advance position and in the rear positions, because time and a certain amount of tranquillity is necessary for building them.

Frequently machine guns are placed in the open, either in the trench or even forward in the shell craters. The gunners then have a special shelter, connected with the machine gun emplacement by a communication trench or by a sap coming out on the surface through a shaft.

(c) The observing stations, by reason of their positions, need very thorough protection. As a rule they are constructed of concrete. It is often possible to construct shelters for the men on a slope hidden from view, and to cut a tunnel having a loophole on the enemy's side.

It is quite evident that, whenever possible, natural cover of the country must be utilized. In many places use is made of former stone quarries, or of house cellars. In the latter case, the vaulting is reinforced by materials from the demolition of near-by houses. Both quarries and cellars make excellent shelters. In connecting one shelter with another, bomb-proof communications are constructed to facilitate coming and going. Each cantonment ought to have bombardment-proof shelters for the garrison, either in the cellars or outside the village.

It is very important to hide the artificial shelters from view. To this end, they must be carefully concealed, not only after their completion, but also during construction, because aerial photographs infallibly reveal the slightest modifications made in the appearance

of the terrain. The works are disclosed by the change in color due to the overturned earth, by the tracks made by a constant circulation over the same routes, and by the traces of ditches dug for the underground telephone lines, which are visible even after the ditches have been filled in.

In the organization of all parts of a position, the construction of shelters comes after the construction of obstacles (wire entanglements) and flanking works (machine guns), but before the deepening of the trenches.

NOTE.—Upon arriving at the front, the American Army will find an existing situation, and will first have to perfect the shelters. But later on it will have to organize an entire position. These indications aim at a clarification of the French regulations, which are, unfortunately, rather barren.

GERMAN LAND MINES.

DESCRIPTION OF MINES AND FIRING APPARATUS, ETC., EXTRACTED FROM THE "SPRENGVORSCHRIFT."

Land mines are employed on the roads likely to be used by the enemy during an advance; on probable sites for batteries and parks; in ground defiladed from view of the German position; in combination with other obstacles; to increase the difficulties of hostile reconnaissance and destruction of obstacles; and particularly in front of a position in danger of assault. Both observation and contact mines are employed.

Mines are marked in some way to insure that German troops do not march over them. but this is done in such a manner that the marks are not likely to attract the attention of even a wide-awake enemy.

(According to Belgian accounts mines have been placed in buildings, under pavements, and even in soldiers' graves, with the corpses over them.)

OBSERVATION MINES.

These are fired electrically. They can not therefore be very far from the position that they defend. They are generally to be found in front of permanent or semipermanent fortifications, the leads having been laid during the construction of the works. They are seldom employed in field works on account of the great length of wire required. Observation mines are laid in groups of 3 or more, each group in continuous circuit. The charges used and the depth at which they are placed vary. To stop an assault they are laid either 30 to 50 cm. (12 to 20 inches) under the surface, so that the high explosive acts direct on the enemy, or 1 to 2 meters (3 feet 4 inches to 6 feet 8 inches) deep, so that masses of earth are thrown up. The effect is sometimes increased by covering the mines with stones (see fig. 1). In this case the mines in a group may be from 50 to 75 meters (55 to 62 yards) apart. The charges are so calculated that when a group is fired only a shallow trench is formed, which gives no appreciable cover to the enemy.

The leads are buried at least 30 cm. (12 inches) under ground to avoid damage, and those of different groups are laid 2 meters (6 feet 8 inches) apart so that the same shell can not disconnect two groups.

The firing station is situated so as to secure good observation of the mine field, both by night and day. It is provided with light-

OBSERVATION MINE.

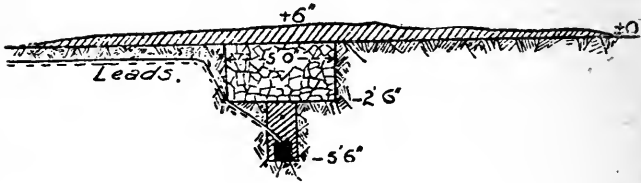

Fig. 1.

CONTACT MINE.

Top View.

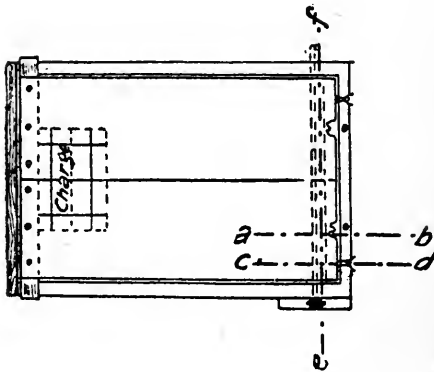

Fig. 2.

ball pistols and, if possible, a searchlight. These may therefore give a clue to its position.

CONTACT MINES.

Contact mines, if used in large numbers, are generally laid out in mine fields. As they are as dangerous to German troops as to the

CONTACT MINE.
UNDERSIDE OF I.I.D.

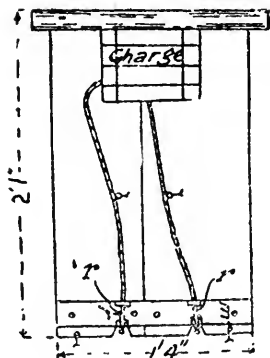

Fig. 3.

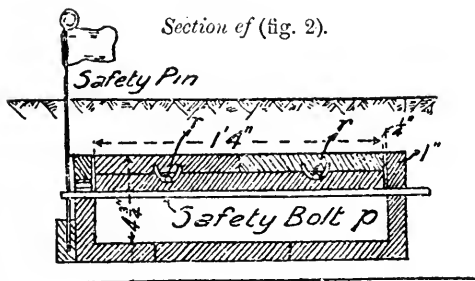

Fig. 4.

enemy's, it is considered desirable that they should be kept ready but not laid until shortly before they are wanted. When the opposing forces are very close to each other the mines are sometimes

used singly to block approaches and breaches, and in ditches, etc. They are often laid in craters made by shells.

One kind of contact mine is fired by treading on it. The means of firing may be mechanical or electrical. The board used as contact maker is about 40 cm. (16 inches) broad and from 40 cm. to 80 cm. (16 to 32 inches) long. A larger surface is apt, it is considered, to betray the presence of the mine even if only recently laid. About 5 to 10 cm. (2 to 4 inches) of earth is laid on the contact maker, with a piece of sailcloth or similar material under to prevent the soil getting into the mine. The charge is from 4 to 22 lbs. of high explosive.

The mechanical contact mine is made in the form of a wooden box (see figs. 2 to 6) with a lid fitting loosely inside it. One end of the lid is pivoted; the other is prevented from falling inwards by two loops of three strands of copper wire. Each loop is attached to a nail or screw "n" (fig. 5) on the end of the box and passes round another nail "m" on the underside of the lid. A space of about 2 to 4 inches is left between the lid and the end of the box so that the lid can fall and is not jammed when it is trodden on and the wire loops are broken.

Two mechanical fuze lighters "rr" with fuze leading to the charge are screwed to the lid (figs. 3 and 6). A description of the lighter is given below. The firing pins are attached by wire to a screw or nail "o" (Fig. 6) on the end of the box. When the pins are drawn by the lid dropping the fuze lighters are set in action.

A safety bolt "p" is provided which is withdrawn after the mine has been laid.

The mechanical fuze lighter is shown in fig. 7 which sufficiently explains it. It is made fast to the lid by a clip with screw fastenings.

The charges are made up to the required weight in "cartridges," each containing 1 k.g. (2.2 lbs.) of explosive. The "cartridges" consist of 5 slabs, each wrapped in paraffined paper, and inclosed in a tin box about 20 cm. by 7 cm. by 5 cm. (8 in. by 2.8 in. by 2 in.) On three sides of the box (fig. 8) will be found a hole covered with parchment paper for insertion of the fuze. Wires "ww" are soldered alongside the hole to secure the fuze.

THE ELECTRO CONTACT MINE

is, in its general appearance and method of attaching the lid of the box, similar to the mechanical one, but it is fired by means of an electric fuze. The battery is buried near it. When the lid is trodden on, a contact is made between metal strips attached to it and to the body of the box (see fig. 9).

CONTACT MINE.

Section cd. (fig. 2).

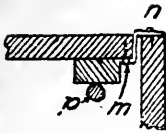

Fig. 5.

Section ab. (fig. 2).

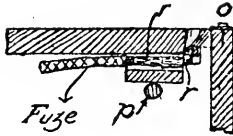

Fig. 6.

MECHANICAL FUZE LIGHTER.

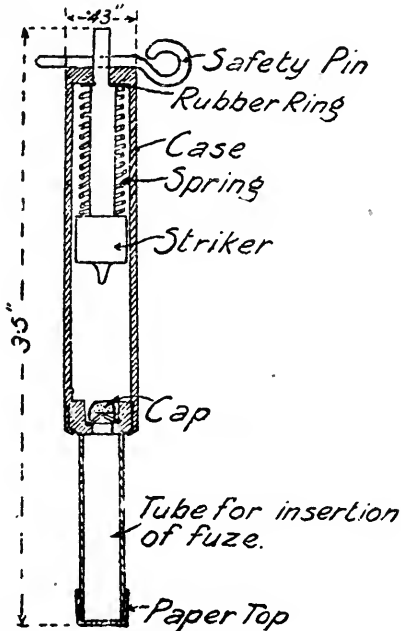

Fig. 7.

TRIP WIRE MINES.

These mines are fired by the enemy cutting or disturbing a wire attached to them. As trip wires are difficult to conceal even in long grass, this type of mine is as a rule used only close in front of the position or in, or in front of, a wire entanglement. If used at a

CARTRIDGE.

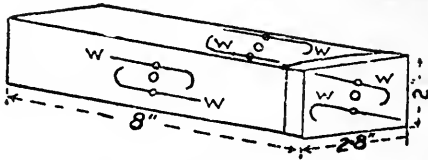

Fig. 8.

ELECTRO CONTACT MINE.

Section.

Fig. 9.

greater distance they are placed where their removal can be hindered by fire.

A special mechanical fuze lighter is used with trip wire mines (see Figs. 10 and 11), but the fuze lighter already described can also be employed.

The mines are laid as shown in figs. 12 and 13. In the former two posts are driven in about 8 meters (9 yards) apart and connected by a

TRIP WIRE MINES.
FUZE LIGHTER.

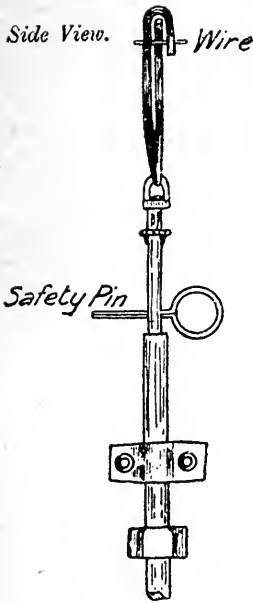

Fig. 10.

SECTION.

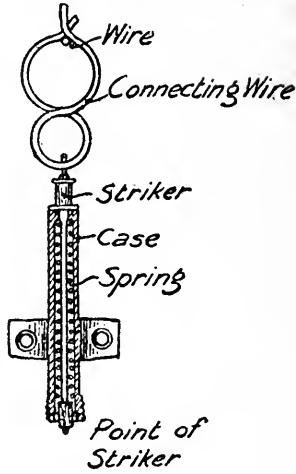
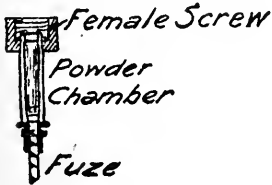

Fig. 11.

POWDER CHAMBER
(which screws on to Fig. 11).



DETAIL OF STRIKER.



thin wire stretched tight. The connecting wire of the fuze lighter is made fast to this wire; the other end of lighter is nailed to the top of a third post so that the lighter is in tension.

TRIP WIRE MINES.

First Method.

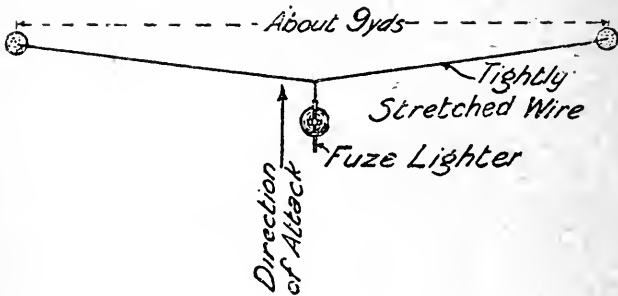

Fig. 12.

Second Method.

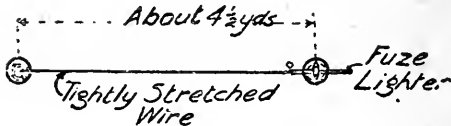

Fig. 13.

The charge is buried in the ground. In laying, the "powder chamber" is not screwed to the body of the fuze lighter until all arrangements are completed; after this has been done the safety pin is removed, from a safe distance, by pulling a cord. The striker

acts if the wire is cut or drawn away from the post to which the lighter is fixed.

GERMAN LAND MINES.

PREPARED TO COVER RETREAT IN BELGIUM.

Electro Contact Mine.

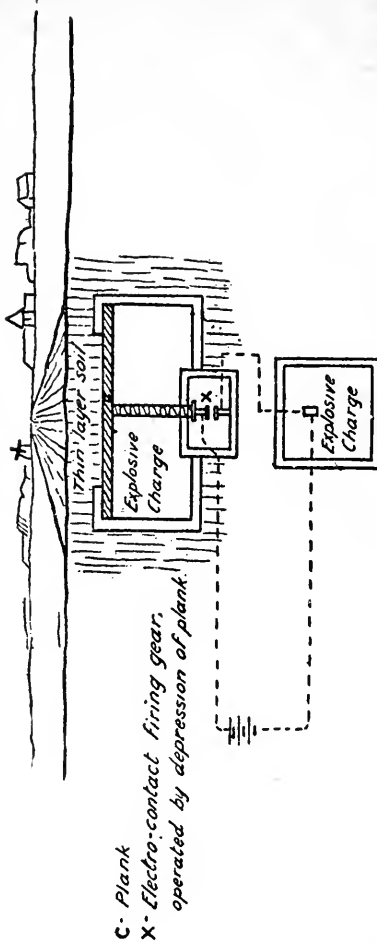
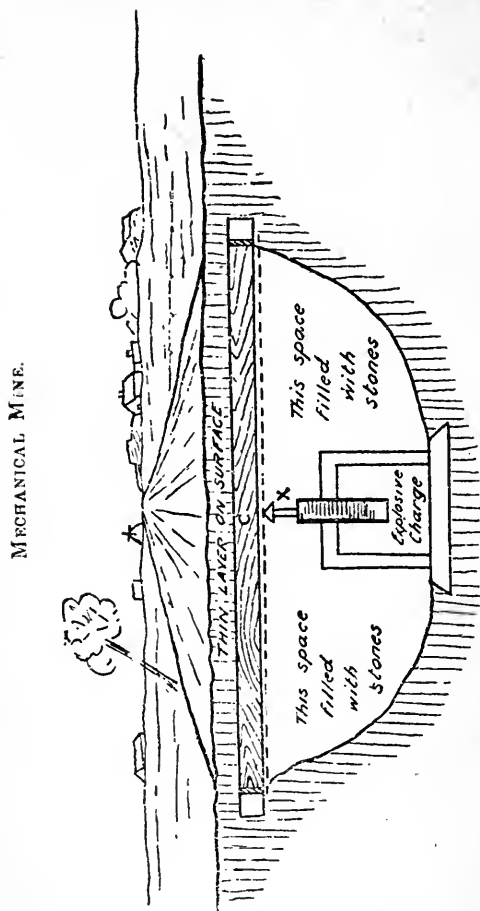

Fig. 14.

In the second form (fig. 13), two posts are placed about 4 meters (4.4 yards) apart; the fuze lighter is nailed on one post and attached by a wire to the other.

DESTRUCTION OF LAND MINES.

The following remarks may be useful as regards the search for and destruction of an enemy's land mines. Great skill and care



C.—Plank.
X.—Firing gear operated by depression of plank.

are required. Suspected localities should first of all be studied with good field glasses. The following signs should be looked for: Freshly turned up earth, settlement of the ground, oval marks on

the ground after rain, patches of grass that stand out conspicuously, narrow strips where the earth has been disturbed which may mark where leads have been laid, ends of wire, cord, and canvas sticking up, numerous foot tracks on a confined space, litter of materials such as powder, guncotton, shavings, paper.

If no signs of mines, or only doubtful ones, can be observed, engineers must be sent to creep forward and reconnoiter. For this purpose they should be provided with wooden mallets and probes. A probe is a thin iron rod about 3 feet long and provided with a handle. If a contact mine is discovered, it should be marked and destroyed later by firing a slab of guncotton on top of it. Trip-wire mines can be destroyed by attaching a guncotton primer to the wire and detonating it, or by firing the mine by means of a long cord made fast to the trip wire. When the leads of observation mines are discovered they should be cut singly and the ends turned up. Contact mines have sometimes been exploded by driving cattle over them. During his march through Georgia, in 1865, General Sherman notified the enemy's authorities that if they did not inform him of the position of their land mines he would be compelled to march batches of prisoners in front of his columns, and found it necessary to carry out his threat. In any case the inhabitants should be questioned as regards mines in roads and buildings.

The simplest way to clear suspected localities, for instance lanes left through obstacles, is by firing a long line of small charges. Single charges of 100 lbs. of high explosive are effective for destroying contact mines within a radius of 38 yards by the force of the explosion alone, but they are useless against trip-wire mines.

The artillery can give much assistance in preparing the way for the engineers.

Figs. 14 and 15 represent land mines reported to have been laid under roads in Belgium. No reason is given for the two charges in fig. 15 being arranged for firing in series, nor is it clear whether they are side by side or one below the other. The actual firing arrangements are no doubt similar to those described above.

COMBAT IN WOODS.

TRANSLATION OF A GERMAN DOCUMENT.

The chapter on combat in woods should be particularly emphasized in the noncommissioned officers' course.

General considerations.—When they escape the enemy's view, woods form important supporting points or flanking positions, and may even become the center of the combat. On the other hand, if seen from a distance, they easily draw the artillery fire, and are therefore unavailable for defilade from the enemy's sight, even if they are of small importance. Woods allow small effectives to defend themselves against a larger force, and favor a combat designed to gain time. They aid in deceiving the enemy as to the forces before him. They are also useful when we wish to disengage from the combat and disappear. When our troops occupy woods, the enemy, who still seeks a decision outside the woods, may be forced to employ a large force, out of proportion to the end in view.

I. *Defense of woods by the French.*—The French like outposts and machine guns to push to the edge of a wood, where they construct a wire entanglement. They then establish defensive works in the interior, such as low blockhouses, connected by entanglements. The obstacles are so placed, from the edge to the interior of the wood, that the enemy will be led into *cul-de-sacs* covered by machine guns. Sharpshooters and machine guns in the trees cover the roads and paths. They make great use of sound signals, intended to warn the defenders in time of the enemy's approach. (In the Vosges, Chasseurs Alpines hidden in the trees gave the alarm to the garrison by imitating birds' cries.) The defense is prepared in an offensive manner (prepared ambushes), and above all with the object of falling on the enemy's flank when it advances without method.

II. *Combat on the edge of the woods, and advance into the woods.*—The edge of the woods is taken like any other position. Only in sparse woods should the advance be made rapidly to the opposite edge and the machine guns placed there in position. Infantry detachments with machine guns surround the woods. The difficulty arises when the woods are large.

Instructions: Advance for about 50 meters in the woods. Place pursuing patrols in advance on all roads; outside the wood, have strong combat patrols in liaison with the troops on the roads leading from the edges to the interior.

Mark out carefully the direction of the march (with a compass). Fix the leader's position. Assure transmission of information. Bring up the led horses, ammunition wagons and combat train.

The following points are important while waiting to encounter the enemy in the woods:

The formation of the troops depends on the density of the woods. A close line of skirmishers with supports following closely is best suited to open woods. The skirmishers should be grouped in dense woods. In echelon formation, often designated by the name "wood formation" (waldformation), has shown itself effective in dense woods. The platoons in line of squad columns, the front files acting as scouts, keep near enough not to be lost sight of. The buglers and drummers stay in rear of the front to assure the liaison, which is much more useful than blowing a bugle or beating a drum. The small column can quickly deploy for fire and easily make its way through the woods. Weapons are carried in the hands. Absolute silence is maintained. The advance is slow. The question whether it is well to keep the troop outside the woods in touch with the advance by means of illuminating signals should be studied. The men should not debouch in clearings or on wide roads and should not leave the opposite edge without taking precautions. Precautions must be taken against asphyxiating shells.

3. *Encounter with the enemy in woods.*—Note the importance of the surprise. Allow the enemy to come under fire, then follow the surprise with an attack. Choose the quickest and strongest men for lookouts. Choose their positions carefully. Whenever the enemy is repelled, he must be forced back vigorously in order to avoid a return offensive. At the same time the liaison to the rear and to the flanks must be kept up. Special detachments must be detailed to clean up the captured position, as there is danger of receiving blows from the rear from small detachments which later surrender.

4. *Retreat across woods.*—The woods make it easy to break contact in the retreat. An able defensive may be maintained by a weak rear guard. The enemy's overhasty efforts can be checked until the main body of friendly troops are safely on the march in the desired direction or are in a position to make a counterattack. It is usually easy for the rear guards to draw the enemy in a desired

direction favorable to the counterattack. It is well to be abundantly supplied with machine guns in order to economize the infantry. Protect the forced retreat and the taking up of positions with good field of fire by means of shock groups armed with machine guns and using the inequalities of the ground. Retreat by rushes.

5. *Combat in woods in position warfare.*—In combat of long duration in woods in position warfare the trees disappear little by little, and the field of view is disclosed. At the beginning of an action in large woods the artillery is not very effective; but its effectiveness increases gradually, particularly in combat of long duration, thanks to the use of technical methods.

When attacking well-defended woods, shock groups armed with machine guns, light trench mortars, and flame throwers should precede the assaulting waves.

The trace of the works, the entire trench system, and the method of occupation of the enemy's position are very difficult to determine. Information on these points, as well as on the flanking works, should be obtained by reconnaissance patrols and observation from the trenches before an attack is carried out. Great attention is paid to the organization of the infantry and artillery observation.

The sharpshooters and machine guns hidden in the trees should be specially watched. These should be rendered harmless by spraying the tops of the trees with machine-gun fire before the main body of the troops enter into action.

The woods offers to the defense the essential advantage of concealing works from the enemy, and even from the aviators. Methodical bombardment of these works by the artillery is very difficult.

A wood lends itself to the construction of surprise works, such as machine-gun blockhouses. Counter attacks against the enemy, who may have penetrated the line, is easy for the defender who knows the terrain.

Abatis do not form good obstacles. They dry up rapidly, and enemy patrols and artillery fire may set them on fire. Bombardments inflict great damage upon them.

Men familiar with life in the woods should be chosen for the listening posts—foresters, hunters, woodcutters, etc. It is possible, by minutely observing the motions of the birds, to determine the position of enemy observing stations in the trees, or the approach of enemy patrols. The flight and the perch of the birds give indications of the enemy's presence. Birds flying toward the large trees and suddenly startled a short distance from them may betray the presence of sharpshooters.

NOTE ON MONT CORNILLET TUNNEL.

During the late operations on the French front the Germans have made great use of "tunnels," or underground shelters of great capacity, to permit important reserves to be kept as near the front line as possible. These reserves generally escape the preparatory fire and are ready to carry out strong counterattacks on the enemy who is assaulting the first lines.

In this connection may be noted the cases of the old Didier Mill, east of Filain, accessible to wagons and capable of holding three companies; the quarries north of Colligis, which can hold 3,000 men; the Kohlershole, west of Froidemont, where two battalions were sheltered before the attack on May 18; the Brimont gallery, capable of holding a battalion; the underground galleries on Hill 108, etc.

The Cornillet Tunnel.—A similar tunnel, located in the Cornillet Hill, played an important part in the April-May operations in Champagne, and while it presented the advantages of this type of work, it also showed their disadvantages.

The Cornillet was of great importance to the Germans as an observing station and supporting point. A line of trenches behind wire entanglements surrounded the summit. The trenches offered little shelter, but a tunnel with three entrances on the northern slopes afforded shelter for important reserves.

Its construction.—The tunnel contained three galleries, each about 300 meters long and 2 to 3 meters wide, cased with timber on the inside. The galleries were united by a transverse corridor about 50 meters from the entrances. The entrances, one to each gallery, are north of Cornillet and south of the edge of Wood B-47. The principal entrance is that of the central gallery, at the end of a path coming from Nauroy. Ventilation was effected by several chimneys, aided by hand ventilators. The tunnel was capable of holding 3 battalions (one to each gallery), 10 days' reserve rations, and a large amount of munitions of all descriptions. Supply service was made at night by the transport troops at Beine, where the wagons stopped. Between the entrances of the tunnel and the summit of Cornillet, a line of strongly constructed shelters was established for the machine gunners and the grenadiers.

Its part in the attacks of April 17 and May 4.—At the time of the attacks of April 17 and May 4, our destructive fire was unable to do any permanent damage to the tunnel, and the garrison successfully repaired the damage to the entrances. The garrison

remained fresh, and carried out several counterattacks with success, aided by the resistance of several groups of defenders on the outside which were amply provided with light machine guns.

Its part in the attack on May 20.—On the night of May 19-20, fire with special shells on the entrance overcame the pioneers and prevented them from repairing the damage. On the morning of the 20th fire with 400 cm. shells was used on the tunnel, doing great damage. One shell, penetrating by a ventilating shaft, overthrew the intersection of the transverse gallery, crushed the room containing the two battalion commanders, killing one and mortally wounding the other. A part of the garrison was asphyxiated, and the remainder demoralized. The stopped-up exits could not be excavated.

The garrison, comprising the 2 battalion commanders, their adjutants, their liaison personnel, several artillery officers, 6 infantry companies, the elements of two machine-gun companies, 4 pioneer platoons, 1 dressing station, 1 detachment of earth conduction telegraphy, were grouped less than 500 meters from the first line, and had no chance to intervene after the assailant had passed the first line.

Our attack, following the barrage fire step by step, reached the outlets of the tunnel before the defenders noticed it and no troops could leave the tunnel.

Conclusion.—To sum up: The Cornillet Tunnel effectively sheltered a very strong garrison as long as it was not subjected to a heavy bombardment. But from the time our large calibers reached it effectively, and its defenders were prevented from repairing the damage inflicted on its few outlets, which its proximity to the first line rendered inevitable, one single round shut in this important command and made it unavailable.

TACTICAL PRINCIPLES IN DEFENSIVE COMBAT, POSITION WARFARE.

[Translation of an official German document of March, 1917, captured by the French.]

EDITED BY THE WAR COLLEGE, JULY, 1917.

1. INFANTRY.

Energetic measures are taken to see that the infantry on the line continues its work on its positions, even during combat. All infantry officers and officers of higher rank make certain of this by personal inspections.

At night, and particularly in foggy weather, it is often necessary to reinforce the first-line garrison or to bring up the reserves nearer to the first line. In foggy weather a special form of alarm should be arranged.

The shell holes between the defensive works are a source of danger. They should be filled up by fire from the rear and flanks and watched by the infantry and artillery. At night in foggy weather they should be guarded by advance posts.

When the reserves are in position, it is essential that they be kept hidden and be divided skillfully on the terrain to avoid all unnecessary losses. Avoid isolated farms, small woods, dales, and depressions, as experience shows that these are always violently bombarded.

When the action is on exposed ground or in positions that offer little shelter, the first line must be held by small detachments, while the rest of the troops are echeloned in great depth, as if in a thoroughly fortified position.

When an enemy attack commences with a long and intense preparation by large and very large caliber artillery and by trench mortars, the first trenches are rapidly changed into shell-hole positions, in which groups of riflemen, composed of isolated squads, form around the lookout posts and the shelters, wherever these still exist.

It is essential that the men be trained to join these points together and to unite them to the trenches in the rear, taking advantage of lulls in the combat, of night, or fog.

The influence of the company commanders and the platoon leaders during combat in shell-hole positions is felt only by those men who

surround them. In these circumstances, courageous men with iron nerves become the backbone of the combat. Nevertheless, the leaders on the first line, superior officers, or subalterns, by their calm attitude and their example, should seek to keep their men in a state in which they can resist or counterattack rapidly.

It is not necessary in combat of this nature to reinforce the first-line garrison nor to send up reinforcements continually. The garrison suffers increasing and repeated losses, which, being useless, undermines the morale of the troops. The more advanced positions can not be held simply by a rigid defense, combined with reinforcing the first-line garrison. To obtain this result, tactics of a different nature are required.

The number of men holding the first line should not be large, and the men should not be rigidly held in a position in which they can no longer find shelter, but should, within certain limitations, change their position to escape an intense bombardment. Experience shows that, no matter how carefully the enemy directs his fire, there are portions of each sector assigned to a unit where the fire is less effective. The point of fall of enemy projectiles should be observed, and one should avoid the more intense fire by advancing, by drawing off to one side, or by falling back on the nearest supporting lines. The best method is to advance, as that is the quickest way to avoid the enemy's fire. In movements toward the flanks, or toward the nearest supporting trench in rear, there is some danger that the continuity of the firing line will be broken, and that the enemy will establish small outposts without being noticed. The detachments in the shell holes should not therefore lose sight of each other, and the first line should constantly be watched from the rear.

If the enemy infantry leaves the trench to attack our lines each infantry soldier should remember that the surest means of repelling an attack are his rifle, hand grenades, and bayonet, and that even a few machine guns are sufficient to break up an attack. The use of artillery barrage to throw back an attack is of great value, but is not of itself sufficient to repel violent attacks.

All rifles and machine guns that can operate effectively, whether on the firing line or on the defensive positions in the rear, should be trained on the enemy's attack. In addition, destructive fire and artillery barrage, trench mortars, and grenade mortars also take part.

If, in spite of this, the enemy manages to penetrate into our trenches, the artillery's task is to cut off the attacking waves and reserves that follow by barrage and annihilating fire, while enfilading

and frontal fire (rifles, automatic rifles, and machine guns) is directed at the enemy infantry who have penetrated into our trench to prevent their advance. Trench and grenade mortars, especially, should be used against the enemy while he is taking up the position. The artillery also takes part, provided that observation can be secured.

The difficult situation in which the enemy is now found should be followed up without waiting for further orders. The detachments from the trench garrison retiring on the flanks and rear, as well as the supports who are held behind the first line and whose rôle must be as second nature to them, should promptly counterattack and retake the first line. They must, in certain cases, fall under the enemy's artillery fire. In hand-to-hand combat the enemy must be destroyed to the last man by hand grenades and bayonets. An essential condition of success in these tactics is to establish observation, by the infantry, of the terrain which extends in front of the trenches and between the lines.

The security posts do not take part in these counter attacks.

If the counter attack is successful, the first line should immediately be put in a state of defense, but the garrison of the trench should be reduced to its original number. *In this way, the action does not take place in the first line, but for the first line and around it.*

It is essential that the men be thoroughly trained in these tactics, and that the subordinate officers receive precise, clear, and detailed instructions as to what they are to do, and when and where they are to do it. The greatest effort each man is capable of should be demanded of those taking part in the attack.

If the troops who are in the advance area of the attack can not throw back the enemy or hold him, a combined attack of general reserves should be made while the enemy is still occupied with preparing the defense of an unfamiliar trench system and fighting with local reserves for the possession of supporting points, etc. Each man who fights in the advance zone should clearly understand that, by holding on, even if completely surrounded, he is making easier the counter attack, which will surely be carried out, and that he is thus contributing to his own rescue. He must therefore fight as long as he can make use of his weapons.

The attack itself should be carried out in light waves, attacking detachments being used on isolated points. The attack should be supported by the fire of machine guns echeloned in advance, by grenade mortars and trench mortars, by infantry guns, and by the artillery situated more in the rear. The success of these attacks de-

pend, not on the strength engaged, but on the energy of will, the cooperation of all means of combat, and the rapidity of execution.

A decisive factor of success is the choice of a propitious moment for the throwing in of the reserves. Experience shows, on the other hand, that demands for reinforcements sent by the first line are often not justified, or are premature. If the reserves are brought up too soon, their combative force is dissipated and the junior chiefs are forced to crowd their lines with too many men.

If an immediate attack does not drive off or annihilate the enemy who has succeeded in penetrating the position, the latter can only be retaken by a methodical attack.

Relief.—Frequent relief of the infantry is not desirable, either from the commander's or the troops' point of view. Changes prevent the troops from familiarizing themselves with the position and diminishes their interest in improving it.

Experience shows that confusion often occurs during the relief and that small portions of terrain are lost.

Precautions must be taken beforehand, in the case of approaches discovered by the enemy and blocked by his fire, to replace them by other well-known and clearly-established communications.

2. ARTILLERY.

Fire on zones (if not confined to narrow limits by means of registration points near the target, coordinated by data obtained from an accurate map) and surprise fire with explosive shells against enemy artillery groups are useless, as a rule. On the other hand, zone fire with gas shells may be very useful to paralyze the artillery temporarily. Gas shells are not used by counter batteries which seek to destroy an enemy battery.

When the trenches are separated by an average distance (150 to 200 meters), barrage fire must fall *on* and *close in front of* the first enemy trench, for otherwise the security of our own trench garrison, which must not be compromised under any circumstances, is not guaranteed. If the enemy jumping-off trenches are so near our own lines that barrage fire may inflict damage on our own troops, bombardment of the jumping-off trenches should be left to the trench mortars, grenade mortars, and infantry. The artillery barrage fire should then be directed against the enemy's rear trenches, so as to cut off his first attacking waves from their supports, and strike the latter while they are concentrating. If the enemy's first line trenches are more distant from our lines (more than 300 meters), the barrage fire should adapt itself to the progress of the enemy's attack.

Artillery action against the enemy tanks is of great importance in repelling attacks because of the novelty of the engines and the lack of experience in regard to them.

Destructive and barrage fire directed against depressions, roads, and enemy positions will often halt the tanks by the density of fire, so that only a few can reach or penetrate our lines.

Infantry guns and close-combat guns with direct fire and short range are used against tanks. These guns are furnished with a special projectile for this purpose. It is important that fire should not be opened too soon, so that the positions of the guns will not be located, and so that they will still be on hand when needed.

Batteries of heavy howitzers are also used to attack the tanks. They have special sectors assigned to them—as a rule, strips of ground near and in front of our lines, which they can observe well, and on which they can get the range for their fire in periods of calm. If a tank penetrates into a zone to which a battery is assigned, all its guns are turned on the tank, and volleys are fired until the tank has been put out of action.

Only a bombardment carefully organized in this way will be successful against the tanks. General orders under which all the batteries which see the tanks approach are to open fire result only in confusion and checks.

In rare instances heavy guns with a flat trajectory, firing direct fire and with direct observation, can be effective if the tanks have penetrated the lines.

Division of the artillery.—The artillery assigned to the armies to reinforce them in a defensive battle should be distributed between the divisions according to the importance of their respective sectors. Artillery should not be massed. Distribution in depth forces the enemy to scatter his fire.

3. AERONAUTICS (INCLUDING ANTI-AIRCRAFT DEFENSE).

It is advisable to increase considerably the aeronautics (reconnaissance and artillery planes, monoplane battle planes, captive balloons, and anti-aircraft guns) before the defensive battle begins, for the enemy's first object is to secure complete mastery of the air. This must be prevented as soon as possible.

When the situation is clear, and the decision to impede the enemy is made, the reinforcement of the menaced front is ordered. The aerial forces and the anti-aircraft defenses are considerably increased. Aeroplanes, balloons, and anti-aircraft guns should be withdrawn without hesitation from less important fronts.

4. PIONEERS.

(a) The pioneers should never be employed on any works that the infantry can carry out.

(b) The divisional chief of engineers also commands the divisional pioneer battalion. The pioneer and trench mortar companies, the divisional searchlight platoon, and, as a rule, the working companies are under his orders. The general commanding the division regulates the assignment and disposition of the pioneer and trench mortar companies, as well as the searchlight units which are temporarily attached to the division.

(c) Defensive action also gives the trench mortars the special rôle of attacking the tanks. As in the case of the heavy artillery, special zones in front of our lines which can be accurately observed are assigned to the heavy and medium trench mortars. If the tanks enter the zones, the designated trench mortars turn their fire from all other targets and direct it on the tanks.

INFORMATION ON THE SECOND ARMY.

METHODS OF GERMAN INFANTRY ATTACK.

In all the combined operations that took place in the region of Verdun from February 21 to April 15 the Germany Army corps engaged by division, side by side, except when the width or the importance of the zone of action assigned to an army corps only called for the engagement of one division, the other division resting in the rear ready to relieve the division extended on the first line.

Example: Seventh Reserve Corps, in the zone between the Meuse and the Bois d'Haumont line (inclusive)—Bois de Caures (exclusive)—Louvemont, February 28 to April 25.

I. ZONE OF ACTION AND DISPOSITION OF THE DIVISION.

The zone of action of a division of three regiments (7,200 rifles) varies in width from 1,000 to 2,500 meters, according to the importance and the number of successive objectives which are presented.

The following examples and their interpretation are taken from sketches and data made from the enemy battle map and completed by data furnished by captured officers.

Example: (1) April 11, the Twenty-first Infantry Division set out on a front of attack of about 1,000 meters, Fort de Douamont (exclusive)—south branch of the ravine of the Fausse Côte—to attack in the general direction of Verdun. The zone of action had an average width of 800 to 1,000 meters; western limit, hill 320—hill 261—point west of woods west of Fort St. Michel; eastern limit, Vaux Road to Hill St. Michel; successive objectives, Bois de Caillette, Fleury devant Douamont, Fort St. Michel.

(2) March 6, the Twenty-second Reserve Division formed for attack on front of about 2,500 meters from Forges Brook (500 meters in front of Forges) up to the Meuse. The zone of action had an average width of 2,000 to 3,000 meters; western limit, 500 meters to north of Forges—point west of Bois de Corbeaux; eastern limit, railroad Forges-Cumieres; objective, Bois de Corbeaux—Bois de Cumieres—hill 265 (east of Bois de Cumieres).

The first example corresponds to a long-range action (zone of action narrow, successive objectives). The Twenty-first Infantry Di-

vision engaged its two regiments side by side on the first line—Eighty-seventh to right, Eighty-first to left—holding the Eightieth in reserve near Bezonvaux. The second example corresponds to a limited range action (zone of action large, single objective). The Twenty-second Reserve Division attacked its three regiments side by side on the first line. In both cases the density of the front attack remained about the same. The front of attack of a regiment varied from 500 to 800 meters.

II. DISPOSITION OF REGIMENT IN ATTACK.

Whatever the division's disposition, the regiment as a rule is formed in depth by successive battalions, in the following order:

One battalion for attack.

Two battalions in reserve, echeloned in depth at distances varying according to the terrain, the nearest ready to intervene to reinforce the attack on the first objective or to make a new attack beyond this objective, the farthest often resting, in this case destined to come to the relief of exhausted units.

Examples:

1st. Disposition of Eighty-first Infantry (Twenty-first Division), April 11. Second Battalion—Battalion of attack in the jumping-off trenches, east part of Bois de la Caillette. First and Third Battalions in reserve in the ravine of the Fausse Côte.

N. B.—These two battalions were first echeloned inside the Bois d'Hardaumont, exposed to our artillery fire and separated from the first line by an exposed space, difficult to cross. They were eventually pushed into the dead angle of the ravine of the Fausse Côte.

2d. Disposition of Eighty-seventh Infantry (Twenty-first Division), April 11. Third Battalion—Battalion of attack, jumping-off trench, west part of Bois de la Caillette.

First Battalion, Reserve—Extremity west from west branch of ravine of the Fausse Côte.

Second Battalion, Reserve—Quarries west of Bois d'Hardaumont.

3d. Distribution of Eighty-second Reserve Infantry (Twenty-second Reserve Division), March 6—

Second Battalion, battalion of attack—When this battalion reaches the first crest southeast of Forges, the two other battalions still remain—one established along the Forges Brook east of the village, the other resting at Bois de Forges.

4th. Distribution of the Fifty-sixth Reserve Infantry and Seventh Reserve Infantry (One hundred and twenty-first Infantry Division), March 31, at the time of the attack on Vaux—

A. Fifty-sixth Reserve Infantry.

Third Battalion, battalion of attack, in the jumping-off trench, north of the Vaux railroad.

One battalion in reserve, near the south point of the Bois d'Hardaumont, ready to reenforce or counterattack.

One battalion in reserve at Bezonvaux Works.

B. Seventh Reserve-Infantry.

Third Battalion, battalion of attack, in the jumping-off trench, south of the Vaux railroad.

First Battalion, in reserve, east of Vaux village.

Second Battalion, rest camp at Loison, 20 kilometers from Vaux.

III. DISPOSITION AND METHOD OF BATTALION ATTACK.

Disposition.—The infantry battalion is nearly always placed on two attacking lines.

The first attacking line is generally formed by two companies, side by side, deployed in the jumping-off trench or the last shelter from which the attack is launched.

The second line is held in the supporting trench, the shelters, or behind a crest.

METHOD OF ASSAULT—WAVES.

Principles.—The principles which follow (the third in particular) are given from explicit statements of captured officers:

1. Each attacking line is always given an objective, definitely and exactly limited (width equal to attacking front, depth usually no more than two successive trenches).

2. The assault is not launched until the artillery has completely overthrown the trenches, destroyed the obstacles, and prevented the defenders from using their arms.

3. The assault itself is preceded by reconnaissances on the objective, whose mission is to verify whether the artillery has obtained the desired results. These reconnaissances form the first assaulting wave. The others do not go forward unless the first advances. What have often been taken to be simple reconnaissances destined to get an idea of our lines have in reality been the beginnings of attacks which we have checked.

Carrying out an assault.—The attacking line debouches by several successive waves. The different methods observed resemble the following types:

Three successive waves at distances of 20 or 30 paces,

First wave: Reconnaissance; 1 or 2 squads to a platoon, accompanied by several pioneers and grenadiers—deployed as skirmishers at very wide intervals.

Second wave: Dense line of skirmishers formed by main body of each platoon. It takes possession of the trenches.

Third wave: Containing the balance of each platoon. It is an echelon, which makes good the casualties and brings up reinforcement of munitions and material (tools, sandbags, etc.), allowing the captured trenches to be turned.

- RÔLE OF SECOND ATTACKING LINE.

This line is reserved principally for a second assault beyond the objective captured by the first line.

In exceptional cases they reenforce the first line of attack or a retreat from an unsuccessful attack.

NOTE.—The assaulting waves are always deployed. The prisoners are unanimous in stating that they have never seen columns of assault used. The impression of small columns following up the first wave is given by stragglers swarming behind the two waves that debouch in dense lines.

Example:—

1. Attack of the Second Battalion, Eighty-second Reserve Infantry, April 9, northwest of Cumieres. This battalion debouched from Bois de Cumieres April 9 at 12 o'clock to attack the French trenches northwest of Cumieres.

First attacking line—Eighth and Seventh Companies side by side and deployed in the trenches on the south edge of the Bois de Cumieres.

First wave—20 men to a platoon, commanded by an officer. The 20 men of the Eighth Company reached in a single rush the first French trench, which had remained nearly intact. They cut a passage with wire cutters through the wire entanglements, and threw themselves in a bound over our first trench toward the supporting trench, where they were taken prisoners or killed.

In view of the failure of the first wave, the second wave debouched half heartedly. Our barrage fire drove them back to the Bois de Cumieres.

2. Attack of the Second Bavarian Division, March 20, on the Bois d'Auvergne.

Disposition of First Battalion of the Twenty-second Bavarians:

First line of attack, Companies One and Four.

First wave, 8 to 10 men to a platoon, and 15 to 20 pioneers, an officer commanding the whole.

Second wave, 20 men of the platoon.

Third wave, the rest of the platoon.

3. Attack on the First Battalion of the Thirteenth Reserve Infantry, Seventh Reserve Corps, April 17, on the depression of Heurias.

First line of attack, Second and Third Companies, side by side, deployed.

Second line of attack, First and Fourth Companies.

The first line of attack formed three successive waves, each a platoon. Several pioneers were attached to each wave.

4. Attack of the Second Battalion, Eighty-seventh Infantry, April 11, on the Bois de la Caillette.

The Second Battalion, Eighty-seventh Infantry, arrived the night of the 8th-9th to take up a position in the first-line trenches toward the north corner of the Bois de la Caillette. The order of attack for the 11th included taking the forward French trench (Trapeze trench) and forcing their way to the supporting trench.

Disposition of II/87.

Two lines of attack, each formed by 2 companies, side by side, the Fifth and Sixth Companies forming the first line.

The Fifth Company echeloned in two waves at 30 meters apart, the first wave 40 men strong. The attack was begun about 4:40 p. m. The first wave of the Fifth Company threw itself into an advanced French trench where they were cut off during the evening. The other waves were entirely mowed down by our fire. The second line of attack could not (or would not) debouch.

Attack exercise of the Second Battalion, Two hundred and eighth Reserve Infantry, XXII Reserve Corps.

The battalion recently carried out (beginning end of April) the following exercises in rear of the front during rest periods: Company formed 3, 4, or 5 waves, which left the trench, deployed as skirmishers. The first wave, as mission, taking the French first-line trench, and getting within grenade throwing distance of the second trench. There they were to lie prone on the ground, throw their grenades and immediately after the explosion jump into the trench.

The men each carried 6 grenades and small-size wire cutters.

The second wave had as mission to reach the French line trench. It operated as the preceding one, and advanced when the first wave took that trench.

The third wave carried tools, picks, large-size wire cutters and additional defenses.

The fourth carried a complement of tools and food.

The attack was launched at a given hour. Watches were regulated and the sortie of the waves indicated by whistles. The men taking part in the different waves were appointed by name.

GERMAN CHARGED ENTANGLEMENTS.

(Extracts from Intelligence Bulletin of Dec. 13, 1916, of Seventh Army.)

A soldier, specialist in the study of charged entanglements, who was able during a patrol to approach one of these entanglements in the "Thur" Valley, gives the following information:

1. Luminous haze and sparks are produced the length of the stakes, and on the tufts of grass in contact with metal parts, succeeding each other without interruption.

2. The charged entanglement presents the following appearance:

Two rows of stakes, each stake supporting three horizontal supporting wires of heavy barbed wire. These spaced stakes (following the directions on the diagram) have their base soaked with tar matter or coal tar in order to increase the insulation of the entanglement, and at the same time avoid too rapid rotting of that part of the stake set in the ground.

The two rows of stakes are opposite each other.

Small supporting wires of smooth galvanized wire connect transversely the two rows of stakes. The interlacing of these supporting wires seems to follow approximately the design marked on the diagram.

To complete the entanglement a large double barbed wire (with square sections) connects the two lines of stakes diagonally. This heavy wire is not very tightly stretched.

Several meters in front of the charged entanglement is a large smooth uncharged wire mounted on stakes placed 8 or 10 meters apart and running parallel to the above.

Wire serves as a protection permitting patrols to pass between the two systems with safety.

COMPOSITION OF THE CHARGED ENTANGLEMENT.

CONSTRUCTION OF ELECTRIFIED ENTANGLEMENT.

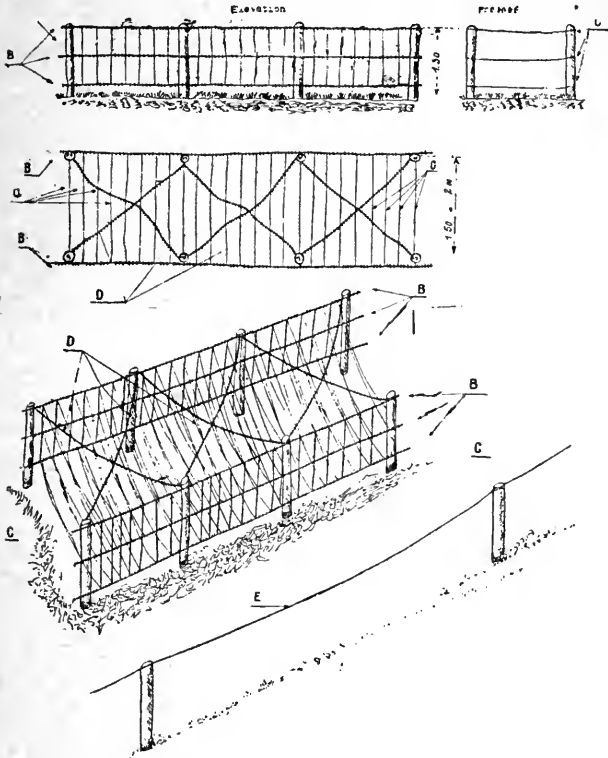

BIRD'S-EYE VIEW OF ENTANGLEMENT.

LEGEND.

- A. Tarred posts.
- B. Supporting wires of American barbed wire.
- C. Strands of galvanized smooth wire.
- D. Diagonal strands of double-barbed wire.
- E. Protective fence of heavy smooth wire.

THE BICYCLE UNITS.

In the beginning of the war there existed only a few bicycle units one or two of which were chasseur battalions.

Since then the number of cyclist companies has been considerably increased by forming a company for each of the new divisions (division of the Reserve Corps XXII, XXVIII, XLI; divisions of the series 50, 101, 201; Ersatz divisions of the series 80, and all the Landwehr divisions).

Some of the old divisions, both active and reserve, will also have a cyclist company.

The cavalry divisions do not seem to have other cyclists than those from the chasseur battalions assigned to them.

Although a new cyclist company has been noted (No. 159) in the First D. C., this seems to be the only case.

There are now about 200 cyclist companies.

Some of them have been formed into cyclist battalions.

A. THE CYCLIST BATTALIONS.

1. ORGANIZATION.

Five cyclist battalions have been discovered; they are numbered from 1 to 5. The third battalion is Bavarian. The first three battalions are grouped and form a brigade which has been called the second cyclist brigade. The fourth and fifth battalions have not been grouped; they appear to be attached to the Eleventh Bavarian Division.

The cyclist battalions have four companies, each having 120 cyclists in addition to one machine-gun company. They have been formed by grouping the existing companies of cyclists which were chosen from either the cyclist companies of the chasseur battalions or from the new divisions organized in 1915.

2. EMPLOYMENT.

The cyclist battalions appeared simultaneously on the eastern and western fronts in September, 1916.

THE WESTERN FRONT.

Two battalions have been formed on the western front. In the beginning they were numbered 1 and 2. They are now the battalions 4 and 5, which are on the Roumanian front.

After having received, in the north of France, the instruction given to the assaulting troops, these units were used on the Somme as ordinary infantry battalions. (See Information Bulletin of Sept. 22.)

THE EASTERN FRONT.

Three battalions have been formed on the eastern front. They are battalions Nos. 1, 2, and 3, and form the second cyclist brigade.

The second cyclist brigade fought during September in the Carpathians; during October, in the Dneister Valley (in defense of Halicz) and then again in the Carpathians.

In November this brigade was transferred to the Orsova district, where it fought against the elements of the Roumanian army, which had been cut off from their army while defending this district and the sector of Vidin.

At present the second cyclist brigade seems to be in rear of the front, southeast of Buzeu.

The fourth and fifth cyclist battalions, transferred from the Somme district to the eastern front, seem to have been assigned to the Eleventh Bavarian Division, with which they fought in Roumania. At present they are still with the Eleventh Bavarian Division, which is also southeast of Buzeu.

Up to date the cyclist battalions appear to have been considered as a mobile infantry reserve, which is at the disposal of the large infantry units.

As a rule they have been used where quick intervention by fresh troops was necessary.

They seem never to have acted in liaison with a division of cavalry. However, it is possible that in the future the five cyclist battalions in question, which are now in the Moldavian Plain, near the corps of the Schmettow cavalry, may be put at the disposal of this large unit.

B. THE MACHINE-GUN COMPANIES OF THE CYCLIST BATTALIONS.

The following information, relating to the organization of the machine-gun companies of the cyclist battalions, is taken from an official document which was seized on the eastern front and then sent to the Russian staff:

In July, 1916, the school for machine gunners at the Doberitz Camp had to organize the machine-gun companies for each of the first and second cyclist battalions. The Bavarian ministry of war had to supply the company necessary to form the third cyclist battalion (Bavarian).

I. The machine-gun companies comprise:

3 officers, 1 of whom commands the company.

62 noncommissioned officers and privates, namely:

1 "feldwebel."

1 "vice feldwebel."

6 noncommissioned officer gunners.

1 noncommissioned officer armorer.

1 noncommissioned officer hospital orderly.

34 "gefreite" and soldiers.

2 noncommissioned officers from the automobile service.

12 mechanics, automobilists and substitutes.

1 motorcyclist.

3 "train" soldiers.

which means the usual strength of a machine-gun company is reduced by 1 officer and 23 men.

The machine-gun companies have 6 guns (3 sections of 2 guns). Its train has only one four-wheeled wagon.

II. Means of transportation:

The company (personnel and matériel) is transported in automobiles, namely:

1. One four-seated touring car for use of the company commander. For changes of stations and reconnaissances the other officers may also sit in this car; otherwise they go on a truck.

2. Five 3-ton motor trucks. The first three trucks are for transporting the company. Each of them carries two machine guns with their munitions and gunners, which means an entire section. These three loaded trucks form the "Fighting unit." When there is sufficient room they also carry the folding pushcarts, which facilitate the transportation of the guns beyond the roads to which the trucks are necessarily confined.

The fourth truck is for the baggage, ammunition, and accessories (tools, spare parts, etc.). The "feldwebel," the "vice feldwebel," armorer, and noncommissioned officers, hospital orderly, and all the extra personnel also ride on this truck.

Each gun is supplied with at least 15,000 rounds, the greater part of which is put on the first three trucks.

The fifth truck carries the gasoline supplies and various matériel. The food, clothing, etc., should be properly distributed between the different wagons.

III. Armament and equipment:

All the men are armed with automatic pistols; only the "train" soldiers carry carbines.

The "feldwebel," the "vice feldwebel," and the gunners are supplied with field glasses of the 1903 model. There is no telephone apparatus.

METHOD OF THE GERMANS IN ESTABLISHING LINES OF DEFENSE.

(Extract from Intelligence Bulletin of the Sixth Army of Dec. 9.)

The methods which permitted the Germans during the course of the battle of the Somme to establish in a minimum of time relatively strong new lines of defense depended on a number of qualities and conditions which may be summed up as follows:

Methodical disposition.

Practical ability.

Specialization.

Great demands upon troops.

1. The echelonning in depth of the troops occupying a sector is the object for the echelonning of successive positions of defense already existing or to be created. This is a cardinal principle and is carried out rigorously. As a result the trenches are always constructed or improved by workers in the vicinity.

As changes among the battalions of the first line, support, or reserve, cause an inevitable obstacle in the continuousness of work, this inconvenience is reduced to the minimum in the following manner:

Every position in construction is divided into several working sections, usually corresponding to the sectors of regiments. The work of each section is permanently directed by an officer (usually a lieutenant) chosen either from the infantry regiment in whose sector the working section is located or from a company of pioneers, for distant positions. The permanence of this officer assures the impetus and continual supervision necessary for the rapid completion of the work. This process is not applicable to the first line, where the work is directed by company commanders. At each relief a detailed report is handed in, giving the work already accomplished, work remaining to be done, material on hand, etc.

2. In order to facilitate the transport of material up to the first position regimental depots have been formed in addition to divisional depots. These former are pushed as far ahead as possible and contain not only material, implements, and wire necessary for the construction of trenches, but also ammunition, provisions (preserved food, mineral water, solid alcohol, etc.). This corresponds to the idea that the units on the first line should find everything they need at the same place.

Transport up to the first line is accomplished on men's backs. The heaviest materials, such as shaft frames, are assembled later.

After disposing permanently of bearers, companies which were normally organized in three sections were split up in 4 sections upon their arrival on the Somme. The fourth section never did any duty on the first line and was entirely assigned to the transportation, each night, of provisions and materials.

3. To accomplish work demanding special knowledge, the Germans have organized special units, such as the "Betontrupp" (charged with constructing concrete shelters) and "Stollenbaukommando" (charged with constructing deep and particularly solid dugouts).

4. Finally the work is pushed to its greatest rapidity. Not only is the amount of work demanded of each man great, since the units are forced to contribute if they are of the first line, support, or reserve, but the number of workers used is very large.

Besides the troops in the sector who construct the two first positions numerous companies of pioneers, divisions coming from other parts of the front before their entrance into the line, battalions of land-sturm troops, Russian prisoners, and probably part of the civil population are used to establish the positions farther in the rear whose plan has been determined upon by the army and which for this reason is called "Heeresstellungen" or "A. O. K. Stellungen" ("Army Oberkommando-Stellungen").

NEW ORGANIZATION OF THE GERMAN COMPANY OF INFANTRY.

The "Proposed Regulation for Instruction of Infantry Troops in the Field" of January, 1917, suggests the organization of the company on the following lines:

I. COMPOSITION AND SUBDIVIDING.

The company is composed of 3 platoons (sections). The platoon is commanded by an officer, or, in his absence, by a sergeant. It is subdivided into squads (groups).

The squad comprises 4 files of 2 men and is commanded by a sergeant or a gefreite (corporal). In war time it forms a squad commanded by the squad leader.

When the number of squads is over 3 the platoon is divided into two half platoons.

The organization of a fourth platoon depends upon the action demanded of the company, whether resistance of long duration or violent decisive action.

In the first instance (long drawn out combat) it is wise to form a fourth platoon comprising a certain number of noncommissioned

officers (platoon and squad leaders), and specialists (detachments for assault) (sturmtrupps), grenadiers, sharpshooters, automatic riflemen, and grenade throwers. This platoon, maintained in reserve, allows the company to conserve its fighting strength for the duration of the action.

In the second instance (violent, decisive action) noncommissioned officers and men, especially chosen, can be united in a *special platoon* and placed at the disposition of the company commander.

In addition to its three platoons the company includes a section of machine guns (infantry machine-gun trupp) for the automatic rifles, or a section of light machine guns, which are just now being issued. To sum up, the German company remains at three platoons as before, but the eventual formation of a fourth platoon is provided for in case of long-drawn-out strain or particular violence of action.

Men using automatic rifles form a special unit belonging to the company but not bearing the title of fourth platoon.

II. MACHINE-GUN SECTION (INF. M. G. TRUPP).

The section is commanded by an officer.

It comprises:

One experienced sergeant taking duties of armament sergeant. To each gun, one sergeant or gefreite in charge of gun, four gunners, numbered 1 to 4 (No. 2 is the aiming gunner), six guns, and one cart for the transport of guns and ammunition.

All the gunners should be trained in the service of aiming.

All in the section are armed with automatic pistols.

The section takes its place as a rule at the left of the company.

During marches the material is placed on the cart, which follows immediately behind the section.

If the march is known to be long, two to four horses are used.

In operation once the material is unloaded the carrying is done by summoning auxiliary carriers furnished by the company.

The number of carriers varies. As a rule a squad of seven carriers and a chief of squad is provided for each gun. They carry ammunition and the water jackets of the guns.

The guns being in position, the squad of carriers becomes a squad of combatants again.

It is to be noticed that the present "Proposed Regulation" mentions six guns to a company of infantry. This number does not yet seem to have been realized. An order of the minister of war dated December 12, 1916, provides for the distribution of only three guns to a company for the end of February, 1917.

NOTES ON FIELD RECRUITING DEPOTS.

Until the beginning of 1915, the young soldiers incorporated into the German Army went directly from their regimental depot (German interior) to join their mobilized corps at the front. Since February, 1915, recruits from all quarters, after a training of from one to three months in the home depots, are sent into field recruiting stations, a variety of instruction camp, where their military education is completed and from which they are sent to the front according to need.

These "Feldrekruten depots" (F. R. D.) are generally assigned to a division, but sometimes to an army corps, for which they serve as a near-by reservoir for forces. Placed only a few kilometers from the front they can send reinforcements rapidly in case of important losses; they can also receive—during periods of inactivity—soldiers from the front whose military training has appeared insufficient under fire. Numerous examples confirm this use of the F. R. D.

They constitute also units to be used eventually in the execution of certain works behind the front, and they have also been used—as a unit or in sections—on the front itself in calm sectors.

Since the F. R. D. follow the units to which they are assigned, in their change of position (*de'placement*) it is probable that cadres are exchanged between the regiments at the front and the F. R. D., which permits of using for instruction officers and noncommissioned officers temporarily unsuited for service at the front.

Because of the frequent change of station of German units it has not seemed necessary to include in these notes the list of the known sites of F. R. D. of the various divisions; however, it is to be presumed that the same material organizations are successively (repeatedly) used by the depots of the divisions which replace each other in the same sector and for this reason a knowledge of their whereabouts is of interest and should be turned over to the second bureau of general headquarters.

The strength of F. R. D. is essentially variable because of their rôle of reservoir; on an average, however, they appear to comprise a battalion of from 4 to 6 companies of 200 men to a division.

They generally receive their recruits simultaneously from the depots of all the regiments of the division; these arrive periodically on one "Sammeltransport." At times, however, the F. R. D. draw

their resources from a region other than their normal recruiting ground; it was in this way that the depot of the Thirty-fourth Division received 600 Bavarians in the beginning of September, 1916.

The resources of the F. R. D. are distributed according to need, without regard to their origin, among regiments which have vacancies to be filled; there is cited the sending of reinforcements from the F. R. D. of one division to the regiments of another division at the front.

THE LIGHT MACHINE GUNS RECENTLY PUT INTO SERVICE IN THE GERMAN INFANTRY.

The Russian staff communicates the following information on the new machine guns whose existence has been known to the Intelligence Service since October 12.

The section of light machine guns (Leichter Maschinengewehr Trupp) comprises 3 groups of 3 guns each.

Each gun is manned by 3 men plus 1 in addition. On the firing line one man carries the gun and the two others transport together 2,000 cartridges.

During marches guns and ammunition are loaded on the carriages of the combat train.

The section is commanded by an officer or provisional officer and the group by a sergeant.

The light machine gun is of the Bergmann system, 1915 model, manufactured at Spandau.

This gun was intended for aviation, but mounted on an aeroplane proved impractical from a technical point of view (worked irregularly during flight).

The gun is air cooled, but is not effective after 250 or 300 rounds of constant fire. For this reason the guns have been grouped in threes, firing alternately a series of 30 shots, giving the impression of fire executed by a single gun.

A prisoner has declared that at the camp of Deberitz there are about 4,000 guns and that their manufacture will be stopped.

This information is to be compared with some other which says that 2,000 men armed with automatic rifles left Deberitz for the eastern front before October 1 and that 2,000 men were still, about the 10th of October, undergoing a course of instruction in this same camp in the use of automatic rifles.

It is to be remembered that 64 sections of light machine guns, about 576 guns, have already been located, and that the 14 sections whose assignment is known are all on the eastern front.

GERMAN HELMET FOR LOOKOUTS.

The new German helmet for lookouts, already referred to at various times, is composed of two parts—the helmet proper, the reinforcing plate in front.

The helmet is of steel, made in one piece, and comes down much lower in back than in front. It is painted gray, has no kind of ornament, and has a stud on each side.

Dimensions of the helmet: Height, 16 centimeters; length (at its base), 31.5 centimeters; thickness of the steel, about 0.15 centimeter; weight, 1.175 kilograms.

The reinforcing plate in front covers about half the helmet; it has two slots designed to fit over the studs on the side of the helmet, and a leather strap with a small buckle, which passes about the back of the helmet and allows the plate to be firmly adjusted. It is of very thick steel; also painted gray.

Thickness of the plate, from 0.45 to 0.50 centimeters; weight of the plate, 2.08 kilograms.

The complete helmet is apparently and actually very heavy, weighing 3.255 kilograms.

We are still without information as to the protection it affords against a rifle bullet; we believe that it assures adequate safety at an inconsiderable distance.



NOTES ON LIGHT INFANTRY TRENCH MORTARS AND MACHINE GUNS.

(Translation from a German Document. One Hundred and eighty-third Infantry Division, Headquarters of the Division, March 27, 1917.)

1. From the maps of the light trench mortar battery positions that have reached me I note that these weapons are not used in sufficient numbers in the infantry positions.

In each regimental sector the 12 light trench mortars of the regiment must be placed in line, as far as possible. The instruction of new gunners can be given with trench mortars in position in many parts of the actual sector of the division. There is no inconvenience in removing them slightly to the rear during exercise hours. It is in firing on the enemy that the gunners will best acquire the habit of fire. Thus, after they have learned the handling of the pieces, with the trench mortars withdrawn to the rear, they can acquire practice with the pieces in action. It is the business of the regiment to provide a sufficient number of trained men to form a regular relief.

I particularly draw attention to the advantage of the cooperation of trench mortars with the neighboring trench mortars, outside of their sectors, even if these mortars belong to another division.

It can easily happen that only a small number of trench mortars are in use in one sector, because the larger part of the position is too far removed from the enemy's lines, while the reverse may be true of the neighboring sector. In this case the sector commanders should arrange to mutually support each other. It may therefore occur that the trench mortars and their personnel are placed under the orders of another sector commander.

Regarding the battery formations of light trench mortars, I again mention that they must be placed in groups of at least four, under a single commander, taking the range into account, so that, being placed behind the first, or better still, behind the second line, they may be less exposed to loss or destruction.

In regard to the placing of machine guns, the following is recommended:

They must only be placed in chance shelters (shell holes, etc.), in exceptional cases, and only during combat. During a period of inactivity care of the material necessitates a carefully constructed machine-gun shelter.

Substitute emplacement for machine guns should be so placed as to offer the same facilities or on the same target as the principal emplacement. If this is not done, a substitute emplacement can no longer be considered as such; it is thus a supplementary emplacement, permitting of fire on other targets. Generally the range is limited to 200 or 300 meters from an emergency mount. This mount can therefore be used only in places (particularly in the first-line trenches) where the targets are generally within this range. In all positions farther to the rear, and in the intermediate positions, fire must be from a sledge-carriage, in order to use the maximum range of the machine gun.

The measures taken for firing at low-flying aeroplanes are in most cases insufficient. On this account the emergency mounts should be fastened to a tree trunk or pile. The earth should be dug around the pile sufficiently deep so that the gunner can work the gun all around the pile. It is only in positions very near to the enemy that this proceeding is not always possible, but every effort must be made to accomplish it.

A supply of hand grenades should be placed in the machine-gun shelters. The exact number can not be generally determined, as it depends on the emplacement of the gun. In any case, the supply should be such that the gunners can protect themselves with grenades during repairs on the guns, and such that, in certain cases, grenade combat may permit them to remove their piece to rear.

(Signed) V SCHÜSSLER.

