

TL
797
U5

NASA SP-30

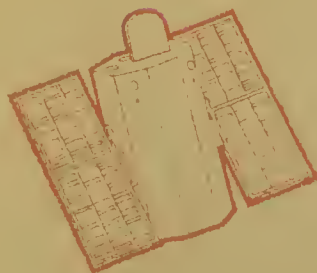

THE OBSERVATORY GENERATION OF SATELLITES

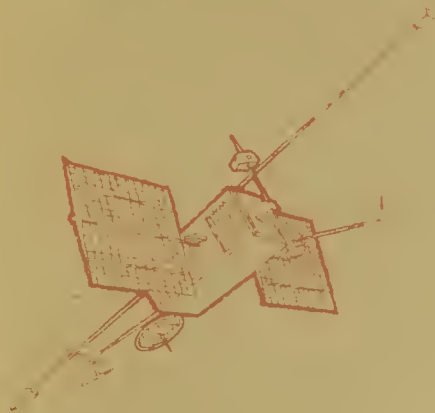

NATIONAL AERONAUTICS AND SPACE ADMINISTRATION

LIBRARY OF
WELLESLEY COLLEGE

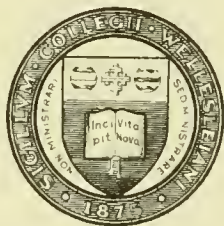

PURCHASED FROM
LIBRARY FUNDS

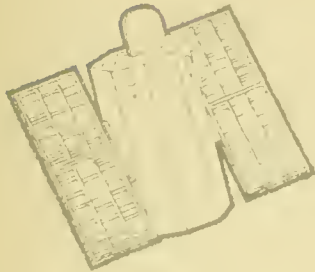

THE OBSERVATORY GENERATION OF SATELLITES

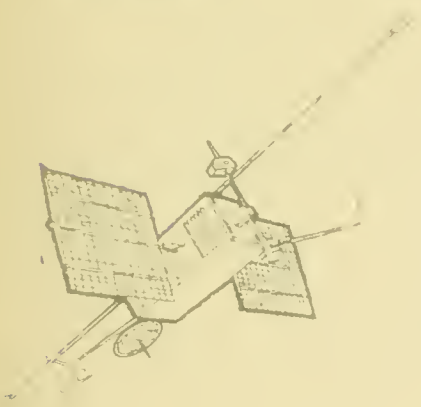

*Session II of a Special Astronautics Symposium held at the
Franklin Institute, Philadelphia, December 27, 1962, during
the 129th Annual Meeting of the American Association for the
Advancement of Science*

Prepared by Goddard Space Flight Center
Greenbelt, Maryland



Office of Scientific and Technical Information

NATIONAL AERONAUTICS AND SPACE ADMINISTRATION

MARCH
1963
Washington, D.C.

FOREWORD

The American Astronautical Society held its second annual regional meeting as part of the 129th meeting of the American Association for the Advancement of Science in Philadelphia, Pennsylvania, December 1962. The six papers presented herein comprised Session II of the Special Astronautics Symposium, "Scientific Satellites—Mission and Design," on December 27, 1962.

The chairman of Session II, "The Observatory Generation of Satellites," was Dr. John W. Townsend, Assistant Director for Space Science and Satellite Operations, NASA Goddard Space Flight Center. The papers are printed in the order of presentation at the meeting, and it is hoped that the reader will find material of interest in all of them.

Technical Information Division
Goddard Space Flight Center
Greenbelt, Maryland

CONTENTS

	PAGE
Foreword.....	iii
1. THE MISSION OF THE ORBITING GEOPHYSICAL OBSERVATORIES... WILFRED E. SCULL	1
2. THE ENGINEERING DESIGN OF THE ORBITING GEOPHYSICAL OBSERVATORIES.....	11
GEORGE E. GLEGHORN	
3. THE MISSION OF THE ADVANCED ORBITING SOLAR OBSERVATORY..	25
JOHN C. LINDSAY	
4. ONE APPROACH TO THE ENGINEERING DESIGN OF THE ADVANCED ORBITING SOLAR OBSERVATORY.....	31
ADOLPH J. CERVENKA	
5. THE MISSION OF THE ORBITING ASTRONOMICAL OBSERVATORY..	45
ROBERT R. ZIEMER and JAMES E. KUPPERIAN, JR.	
6. THE ENGINEERING DESIGN OF THE ORBITING ASTRONOMICAL OBSERVATORY.....	53
WALTER H. SCOTT	

1

THE MISSION OF THE ORBITING GEOPHYSICAL OBSERVATORIES

by

WILFRED E. SCULL*

Goddard Space Flight Center

The Orbiting Geophysical Observatories program has two objectives. The *primary objective* is to conduct large numbers of significant, diversified experiments for making scientific and technological measurements within the earth's atmosphere, the magnetosphere, and cislunar space to obtain a better understanding of earth-sun relations and of the earth as a planet. A *secondary objective* is to design, develop, and have available for launching at regular intervals a standard observatory-type oriented spacecraft consisting of a basic system design that can be used repeatedly to carry large numbers of easily integrated experiments in a wide variety of orbits. As a design objective for the standard spacecraft, it is desired that the spacecraft be capable of reliable operation for a period up to one year in a wide variety of orbits from near-earth circular to highly elliptical cislunar. The current program consists of two missions: the Eccentric Orbiting Geophysical Observatory (EGO), which will be launched from the Atlantic Missile Range in late 1963; and the Polar Orbiting Geophysical Observatory (POGO), which will be launched in early 1964 from the Pacific Missile Range.

INTRODUCTION

The National Aeronautics and Space Administration is engaged in a diversified research program to acquire geophysical data relative to phenomena in terrestrial and extraterrestrial space. Experimental data in these programs have been obtained from spacecraft launched by a series of increasingly powerful launch vehicles with the nature, scope, weight, number, and degree of integration of experiments limited largely by the payload capacity of the vehicles. These weight limitations caused early spacecraft to be tightly integrated sys-

tems of experiments and basic spacecraft subsystems, with resultant difficulties in disassembly and repair or replacement of assemblies if discrepancies occurred during checkout or testing. These early spacecraft weighed 3 to 40 pounds, carried experiments that were largely exploratory in nature, and were integrated so closely with the spacecraft that it was hard to differentiate between experiment instrumentation and spacecraft subsystems. Examples of these early spacecraft are: Explorers I, III, and IV; Vanguards I and II; and Pioneers III and IV.†

As launch vehicles became more powerful, heavier spacecraft carrying from several to a dozen major experiments evolved. Experiments on these spacecraft were designed largely to investigate in more detail the phenomena crudely surveyed—in some cases, discovered—by the experiments in earlier spacecraft. These heavier spacecraft could be divided into subsystems, but it was still necessary to employ a high degree of integration of experiments and spacecraft subsystems to utilize all of the limited launch vehicle capability. The spacecraft were basically systems for single missions in that considerable mechanical, electrical, and thermal redesign and rebuilding were necessary to fly a different set of experiments in a spacecraft of the same basic design. Examples of this class of spacecraft are: Explorers VI, VII,

†Explorers I, III, and IV (1958a1, 1958γ1, 1958ε1) and Vanguard I (1958β2) were launched by other government agencies. Vanguard II (1959α1) and Pioneers III and IV (1958θ1 and 1959ν) were launched by NASA.

*OGO Project Manager, Goddard Space Flight Center.

VIII, X, XI, and XII; and Pioneers I, II, and V.*

Both of these types of spacecraft will continue to play a role in the space sciences program for a number of years. They will be used to carry small numbers of somewhat specialized experiments into orbits that precisely meet their requirements.

The observatories are third-generation research spacecraft. These spacecraft, which make possible the conduct of large numbers of experiments to investigate geophysical phenomena in still more detail, resulted from the concept of spacecraft as standardized containers or carriers for experiments. For the observatories, more complex experiments can be designed to investigate independently the various parameters of a phenomenon and to search for new phenomena that are more difficult to detect. In addition, because of the increasing payload weight capability of the launch vehicles, it was possible to think of experiments and spacecraft subsystems as separate portions of the same system, with the capability existing to integrate any of the subsystems into the entire system. From this background, the *observatory* concept was developed.

The concept of an observatory allowed consideration of a standard spacecraft—standard in the sense of incorporating a high degree of flexibility for accommodating many types of scientific and technological experiments and of operating up to one year in a wide range of orbits. In this manner, it would not be necessary to design and develop a new spacecraft for each mission; instead, a spacecraft of the same design with only minor modifications could be used on successive missions to carry different combinations of experiments. In addition, the observatory could be considered in terms of five individual subsystems:

1. The *basic structure* of the spacecraft within which the assemblies of other subsystems and experiments would be mounted.
2. An *attitude control* subsystem for orienting the spacecraft properly to fulfill the directional requirements of various experiments.

* Explorers VI, VII, VIII, X, XI, and XII are respectively designated 1959δ1, 1959ι1, 1960ξ1, 1961κ, 1961ν1, and 1961ρ1; Pioneers I and V are 1958η and 1960α.

3. A *thermal control* subsystem to maintain temperatures of the assemblies and experiments within a desired operating range.

4. A *power supply* to supply electrical power to the experiments and other subsystems.

5. A *communications and data handling* subsystem to provide a degree of spacecraft control from the ground, to prepare and store experimental and spacecraft operational data, and to transmit these data to the ground.

The advantages that appear inherent in the concept of a standardized observatory include the following:

1. Capability of accommodating a large number of experiments per mission and of performing frequent missions. The frequent missions and large number of experiments that may be directly or indirectly related will allow study and correlation of many phenomena at the same time and same point in space. For example, it will be possible to study simultaneously the relation between solar events, the solar plasma, the earth's radiation belt, and the earth's atmospheric structure.

2. Provision of an attitude control subsystem to control the orientations of experiments with respect to several different references.

3. Convenience to the experimenter in designing his instrumentation by providing a well-defined interface between the spacecraft subsystems and the experiments, thereby allowing each experimenter to integrate his instruments with a minimum of effort.

4. Improved reliability through repeated use and constant stepwise improvement of a basic design of spacecraft in follow-on missions.

5. Provision of conservatively designed power, data handling, and thermal control subsystems for experiments, thereby allowing extreme flexibility in their design.

6. Advantage of being able to handle a limited number of relatively "high risk" experiments late in the program. These experiments will represent a small percentage of the total experiments.

7. Improved operational efficiency through the continued evolution and use of a ground station network, operating procedures, and data processing equipment and techniques.

8. Reduced cost of follow-on missions, on an experiment-pound basis, since development of a new spacecraft for each mission will be avoided.

9. Simplified data acquisition and data reduction, since tracking and data reduction equipment will be matched to a fewer number of different spacecraft designs.

A number of observatories are being developed for the NASA scientific research program. These spacecraft include the Orbiting Geophysical Observatory (OGO), the Orbiting Astronomical Observatory (OAO), the Orbiting Solar Observatory (OSO), the Ranger, and the Mariner. The first three observatories are being developed as a part of the earth satellite program of NASA's Goddard Space Flight Center. The Ranger and Mariner are being developed as part of the lunar and planetary program of the Jet Propulsion Laboratory.

PROGRAM OBJECTIVES

The *primary objective* of the Orbiting Geophysical Observatories (OGO) program, which is a part of the national space sciences long-range program, is to conduct large numbers of significant, diversified experiments for making scientific and technological measurements within the earth's atmosphere, the magnetosphere, and cislunar space to obtain a better understanding of earth-sun relations and of the earth as a planet. A *secondary objective* of the program is to design, develop, and have available for launching at regular intervals a standard observatory-type oriented spacecraft consisting of a basic system design that can be used repeatedly to carry large numbers of easily integrated experiments in a wide variety of orbits. As a design objective for the standard spacecraft, it is desired that the spacecraft be capable of reliable operation for a period up to one year in a wide variety of orbits from near-earth circular to highly elliptical cislunar. During orbital operation, it is desired that portions of the spacecraft be oriented toward and away from the earth and the sun, and forward and aft in the orbital plane.

The current OGO program consists of two different flight missions. The first mission, the *Eccentric Orbiting Geophysical Observatory*

(EGO), will be launched by an Atlas Agena B in late 1963 from the Atlantic Missile Range into a highly eccentric orbit of approximately 31 degrees inclination. Its orbit will have a nominal perigee and apogee of 150 and 60,000 nautical miles respectively. This orbit will allow the observatory to traverse the radiation belts twice each orbital period and to make geophysical measurements from the region near the earth to interplanetary space. The orbital period of EGO will be about 42.8 hours. A "backup" EGO is also scheduled in the event of a catastrophic or early failure of the first EGO.

The *Polar Orbiting Geophysical Observatory* (POGO) will be the second flight mission in the program. POGO will be launched into a polar orbit in early 1964. Launching will occur with a Thor Agena D from the Pacific Missile Range. The POGO orbit, with perigee and apogee of 140 and 500 nautical miles respectively, will allow determination of the ionosphere's characteristics over ranges in latitude and altitude, and the observation of many phenomena directly over the polar regions.

Overall weight of the observatories will be approximately 1000 pounds, of which 150 pounds will be experiments and their associated equipment.

Within the capacity of launch vehicles, future geophysical observatories will be assigned to specific orbits as required by the experiments. In addition, advanced versions of the spacecraft design may have increased weight carrying capabilities or may be launched into higher orbits as launch vehicles of increased capability are developed. The present OGO spacecraft is designed with a growth potential such that it can be expanded to an observatory of 1500 pounds. Most of the increase in weight will be available for experiments. Included in the growth potential may be the capability of carrying and separating in orbit a 300-pound pick-back satellite to perform experiments requiring an especially "pure" environment or experiments that need large separations between two of their parts.

Experiments anticipated for the OGO's include the following general types.

1. *Magnetic Fields*—The magnitude, direction, and variations of the earth's magnetic field and of interplanetary space will be investigated.

2. *Energetic Particles*—The composition, flux, directional characteristics, temporal variations, and energy spectrum of energetic particles (i.e., electrons, protons, gamma rays, etc.) incident on the earth from outer space or trapped in the earth's vicinity will be studied.

3. *Dust*—The composition, flux, and energy spectrum of interplanetary dust in the earth's vicinity will be investigated.

4. *Atmospheric Structure*—The pressure, temperature, composition, and density of the terrestrial and cislunar atmospheres will be studied.

5. *Ionosphere*—Electron and ion densities and temperatures, and ion composition from near the earth to interplanetary space, including the effect of charged particles on the propagation of radio waves, will be investigated.

6. *Solar Physics*—Solar monitors in the ultraviolet, x-ray, and gamma ray regions will be used in correlation with other measurements to understand processes on the sun and their effects on the earth.

7. *Astronomy*—Survey measurements in the ultraviolet, x-ray, gamma ray, and very low frequency regions of the spectrum will be made.

8. *Meteorology*—Observations of the earth will be made with the aim of better understanding the causes of "weather."

9. *Planetary Tests*—Instruments to measure properties of planetary surfaces and environs from planetary spacecraft will be tested on these observatories.

10. *Miscellaneous*—Experimental observations of such things as night airglow radiations, auroral radiations, vehicle charge, electric fields, etc. will be conducted.

11. *Technological*—Tests of power supply, thermal control, structural bearings, mechanical and electronic components, etc. may be conducted.

12. *Biological*—Test to establish the behavior of various forms of life in a space environment may be made.

DESIGN REQUIREMENTS

The concept of a standardized observatory capable of operating in many types of orbits and carrying many different kinds of experiments exerted a significant influence on the design requirements of OGO. For example, the various experiments that required pointing in geocentric and anti-geocentric, solar and anti-solar, and orbital and contra-orbital directions implied 5 degrees of freedom of the spacecraft. In addition, experiments that might be affected by disturbances generated in the main body of the spacecraft imposed the requirement of being mounted at various distances from the main body of the spacecraft. These experiments included magnetic field experiments, whose accuracies would be affected by the small amount of ferromagnetic material that would be used in the spacecraft subsystems and by the magnetic fields produced by incompletely cancelled electric currents. Other experiments that require mounting away from the spacecraft's main body included the following: experiments whose results would be influenced by the presence of a large mass nearby; experiments to measure the properties of the ionosphere and which required minimization of the effects of the plasma sheath and electrostatic potential; and experiments designed to measure properties of the atmosphere and which might be influenced by small amounts of gas evolved from the subsystems or carried from one point to another in space by semi-closed trapping volumes.

The 5 degrees of freedom necessary to accommodate the directional requirements of the experiments implied an *active attitude control* system capable of reducing transients imposed during orbital injection and separation of the observatory from the launch vehicle; of efficiently acquiring the sun, earth, and the orbital plane during the initial sequence; of reacquiring these references for a limited number of times if any of the sensors lost its reference; and of controlling the observatory during normal orbital operations. Desired pointing accuracies during orbital operation were as follows.

Geocentric	± 2 degrees
Solar	± 5 degrees, except it could be ± 20 degrees within 30 degrees of the noon condition
Orbital	± 5 degrees (POGO) ± 5 degrees (EGO), when the angular orbital rates of EGO equaled or exceeded the rates of POGO

A *thermal control* subsystem was necessary to maintain the temperatures of assemblies within the spacecraft's main body in the range of 5° to 35° C and the temperatures of assemblies separated from the spacecraft's main body in the range of 0° to 40° C.

A *power supply* subsystem capable of supplying 50 watts of continuous average power for experiments, plus the power for other subsystems of the spacecraft, was necessary. This average power for experiments consisted of 40 watts continuous average power plus an additional 40 watts on a 25 percent duty cycle.

A *communications and data handling* subsystem was necessary to provide the following functions for a large number of experiments:

1. Process, store, and telemeter experimental and spacecraft data.
2. Receive, decode, and execute ground commands.
3. Radiate an RF signal that would enable accurate determination of orbits.
4. Internally program the data handling subsystem and any high-power experiments on spacecraft having special programmers.
5. Generate both coded and uncoded timing signals for use in the experiments and the spacecraft subsystems.

EXPERIMENTS

Experiments for the OGO's may come from many sources—universities, government research agencies, NASA, and industry. Regardless of the source, all experiments will undergo a series of steps to be fitted into the OGO spacecraft:

1. Experimental techniques must be developed to determine suitability of such techniques for use in the space program.
2. Experiments must be selected for each mission.

3. Prototype and flight instrumentation must be fabricated.

4. Experiments must be tested to determine their ability to withstand and operate under environmental conditions imposed by the launch and orbital environments.

5. Experiments must be integrated into the spacecraft, and the spacecraft-experiment combination must be operated as a complete observatory system, including calibration of experiments and environmental testing of the observatory.

After completion of these steps and following successful launch of the observatory, the experimenter must consider the following events:

1. Operation of his experiment in orbit as a part of the observatory, and recovery of experimental data.
2. Processing the experimental data into a form suitable for analysis.
3. Analysis of the data, and publication of results.
4. Feedback of information obtained during each of these steps and from other programs into the initial phases of preparation for the next observatory.

Experiments proposed for inclusion in the NASA Space Science Program are first submitted to the Director of the Office of Space Sciences, NASA Headquarters, Washington, D.C. Normally, this office supports initial development of worthy experimental techniques to determine their suitability for inclusion in the flight program. At appropriate times, the Office of Space Sciences selects experiments and experimenters for particular flight programs. This process has been completed already for the EGO and POGO missions. Experiments selected for EGO and POGO are shown in Tables 1-1 and 1-2. As indicated in these tables and as may have been inferred from the orbital parameters of EGO, a large number of the EGO experiments are in the category of fields and energetic particles. Likewise, many of the experiments listed for POGO are in the category of atmospheric and ionospheric investigations. However, POGO will also carry several fields and particles experiments.

TABLE 1-1

EGO Experiments and Experimenters

Experiment Title	Principal Experimenter	Phenomenon Observed
Solar Cosmic Rays	K. A. Anderson, Univ. of Calif.	Solar proton and x-ray flux, energy, and variations.
Plasma, Electrostatic Analyzer	M. Bader, Ames Research Center	Solar plasma flux, energy, and direction.
Plasma, Faraday Cup	H. J. Bridge, Mass. Inst. of Tech.	Solar plasma flux, energy, and direction.
Positron Search and Gamma Ray Spectrum.	T. L. Cline and E. W. Hones, Goddard Space Flight Center and Inst. for Defense Analysis.	Search for positrons and solar gamma ray flux and spectrum.
Trapped Radiation, Scintillation Counter.	L. R. Davis, Goddard Space Flight Center.	Geomagnetically trapped electron and proton flux, energy, and direction.
Cosmic Ray Nuclear Abundance	F. B. McDonald, Goddard Space Flight Center.	Primary and solar cosmic ray flux, charge, and energy.
Cosmic Ray Spectra and Fluxes	J. A. Simpson, Univ. of Chicago	Primary and solar cosmic ray flux, charge, and energy.
Trapped Radiation, Omnidirectional Counters.	J. A. Van Allen, State Univ. of Iowa.	Geomagnetically trapped electron and proton flux and energy.
Trapped Radiation, Electron Spectrometer and Ion Chamber.	J. R. Winekler and R. L. Arnoldy, Univ. of Minn.	Geomagnetically trapped electron energy and flux and total ionization.
Rubidium Vapor and Flux Gate Magnetometer.	J. P. Heppner, Goddard Space Flight Center.	Magnetic field strength and direction.
Triaxial Search Coil Magnetometer.	E. J. Smith, Jet Propulsion Lab.	Magnetic field low-frequency variations.
Spherical Ion and Electron Trap	R. Sagalyn, A. F., Cambridge Research Lab.	Thermal charged particle density, energy, and composition.
Planar Ion and Electron Trap	E. C. Whipple, Goddard Space Flight Center.	Thermal charged particle density, energy, and composition.
Radio Propagation	R. S. Lawrence, Natl. Bureau of Standards.	Electron density.
Atmospheric Mass Spectrum	H. A. Taylor, Goddard Space Flight Center.	Atmospheric composition.
Interplanetary Dust Particles	W. M. Alexander, Goddard Space Flight Center.	Micron dust particle, velocity, and mass.
VLF Noise and Propagation	R. A. Helliwell, Stanford Univ.	VLF terrestrial noise, solar particle emissions, and cosmic noise frequency, distribution, and strength.
Radio Astronomy	F. T. Haddock, Univ. of Michigan	Solar radio-noise burst frequency spectrum.
Geocoronal Lyman-Alpha Scattering.	P. Mange, Naval Research Lab.	Lyman-alpha intensity.
Gegenschein Photometry	C. L. Wolff and K. L. Hallam, Goddard Space Flight Center.	Gegenschein intensity and location.

TABLE 1-2

POGO Experiments and Experimenters

Experiment Title	Principal Experimenter	Phenomenon Observed
Radio Astronomy	F. T. Haddock, Univ. of Michigan	Galactic emission at 2.5 and 3.0 Mc.
VLF Measurements	R. A. Helliwell, Stanford Univ.	Terrestrial and other VLF emissions in range of 0.2 to 100 kc.
VLF Measurements	M. G. Morgan and T. Laaspere, Dartmouth College.	Terrestrial and other VLF emissions, and whistlers in range of 0.5 to 10 kc.
VLF Emissions and High-Energy Electron Bunches.	J. R. Winckler, Univ. of Minn., R. M. Gallet, Natl. Bureau of Standards.	Relation between VLF emissions and high-energy electron bunches (5 to 100 kev).
Search Coil Magnetometer	R. E. Holzer, UCLA, and E. J. Smith, Jet Propulsion Lab.	Magnetic field fluctuations in the low audio frequency range.
Rubidium Vapor Magnetometer	J. P. Heppner, H. R. Boroson, and J. C. Cain, Goddard Space Flight Center.	World magnetic survey.
Ionization Chambers: Cosmic Ray and Polar Region Ionization Survey.	H. V. Neher, Calif. Inst. of Tech., and H. Anderson, Jet Propulsion Lab.	Ionization and cosmic rays over polar regions.
Scintillation Telescopes; Energetic Particles Survey.	J. A. Simpson, Univ. of Chicago	Energetic particles 0.3 to 30 Mev.
Galactic and Solar Cosmic Rays	W. R. Webber, Univ. of Minnesota	Energy spectrum and charged particle composition of galactic and solar cosmic rays.
Corpusecular Radiation in Auroral and Polar Zones.	J. A. Van Allen, State Univ. of Iowa.	Net down flux of corpusecular radiation in the auroral zones and over the polar caps.
Trapped Radiation, Scintillation Detector.	R. A. Hoffman, L. R. Davis, A. Konradi, and J. M. Williamson, Goddard Space Flight Center.	Low-energy trapped radiation, 10 to 100 kev electrons; 100 kev to 4.5 Mev protons.
Air Glow Study	J. Blamont, Univ. of Paris, and E. I. Reed, Goddard Space Flight Center.	Air glow in 6300A, 5577A, 3914A, and near UV region.
Lyman-Alpha and Air Glow Study.	P. M. Mange, T. A. Chubb, and H. Friedman, Naval Research Lab.	Lyman-alpha and far UV air glow measurements between 1230 and 1350A.
Air Glow Study, UV Spectrometer.	C. A. Barth, Jet Prop. Lab., and L. Wallace, Kitt Peak Natl. Observatory.	Air glow between 1100 and 3400A.
Neutral Particle and Ion Composition Study.	L. M. Jones and E. J. Schaefer, Univ. of Michigan.	Neutral particle and ion composition, using Massenfilter mass spectrometer.
Positive Ion Study	H. A. Taylor, Jr. and H. C. Brinton, Goddard Space Flight Center.	Positive ions (1 to 6 and 7 to 45 amu), using Bennett mass spectrometer.
Neutral Particle Study	G. P. Newton, Goddard Space Flight Center.	Neutral particles, using Bayard-Alpert ionization gage.
Micrometeorite	W. M. Alexander, C. W. McCracken, O. E. Berg, and L. Secretan, Goddard Space Flight Center.	Mass, velocity, and charge of micrometeorites.
Ionospheric Composition and UV Flux.	R. E. Bourdeau, Goddard Space Flight Center.	Ionospheric charged particles, using retarding potential analyzer.

Following the selection of experiments, support of the experiments is assumed by Goddard Space Flight Center (GSFC). The experimenters and the OGO project staff work directly together to insure that the experimental objectives are met. Approximately 9 months before the scheduled launch date, prototype experiments will be brought to GSFC to be checked for compatibility with spacecraft simulators which simulate the electrical interfaces that the experiment will see in the observatory. In addition, the prototype experiments will be subjected to environmental tests of vibration, shock, thermal-vacuum, temperature, leak (for sealed units), acceleration, and magnetic fields to prove that the experiments are capable of withstanding the rigors of launch and the space environment, and to determine their magnetic properties. Similar tests at lower test levels will be conducted on the flight units of the experiments.

Following testing at GSFC, experiments will be shipped to the prime contractor, Space Technology Laboratories, Inc., of Redondo Beach, California, where the experiments will be given additional bench and interface checks before integration into the observatory. The entire observatory will then be exposed to a series of environmental tests to determine that the entire system will operate together without interference and that it can withstand the launch and space environments. Environmental tests will be conducted with both a prototype and the flight model observatories. After completion of the environmental tests at the observatory level, the observatory will be shipped to the appropriate launch site, where it will undergo detailed hangar checkout before being placed on the launch vehicle. Successful completion of "on-pad" tests of the launch vehicle and the observatory together are required before launch will be initiated.

TRACKING AND DATA ACQUISITION

Tracking and data acquisition for the OGO missions are the responsibility of Goddard Space Flight Center. Tracking of the observatories will be accomplished by a network of tracking stations located throughout the world.

The overall goal of the tracking program is to be able to determine for the experimenter the position of the observatory at any time within a sphere of uncertainty having a radius of 1 km or less at perigee and 100 km or less at apogee of EGO.

Data acquisition for both EGO and POGO will be accomplished by special primary and secondary stations. Selected stations will have the capability to receive and record at maximum data rates all data from the telemetry on OGO. Primary tracking and acquisition sites are Rosman, North Carolina; and Fairbanks, Alaska. Secondary sites are located in Australia; Johannesburg, South Africa; and Quito, Ecuador. All the primary sites will have complete digital and tone command capabilities. All the secondary sites and Minitrack stations will have tone command capabilities. In addition, secondary sites that "see" injection of EGO or POGO will have sufficient digital command capabilities to command a backup observatory deployment and acquisition phase. Injection of EGO will occur near the northwestern tip of Australia; for POGO, injection will occur near Madagascar. In both cases, injection will occur during the second burn of the Agena, which coasts in a transfer ellipse following first Agena burn. Shroud separation will have occurred following burnout of the first-stage Atlas or Thor for EGO or POGO, respectively.

ORBITAL OPERATION

A flow diagram indicating the operation of the OGO in orbit is shown in Figure 1-1. Central control of the observatories will be from Goddard Space Flight Center. Data links connecting GSFC with Rosman and Alaska will be used to give some degree of real-time control of the satellites. GSFC central will have complete facilities to decommutate, extract, display, analyze, and print all data from the telemetry. It will not be necessary that all these functions be performed in real time. However, real-time performance to determine certain parameters, especially for experiments, may be required at specific times. Since the Rosman station, which has an 85-foot parabolic antenna, can see EGO approximately 50 percent of the time and be-

MISSION OF ORBITING GEOPHYSICAL OBSERVATORIES

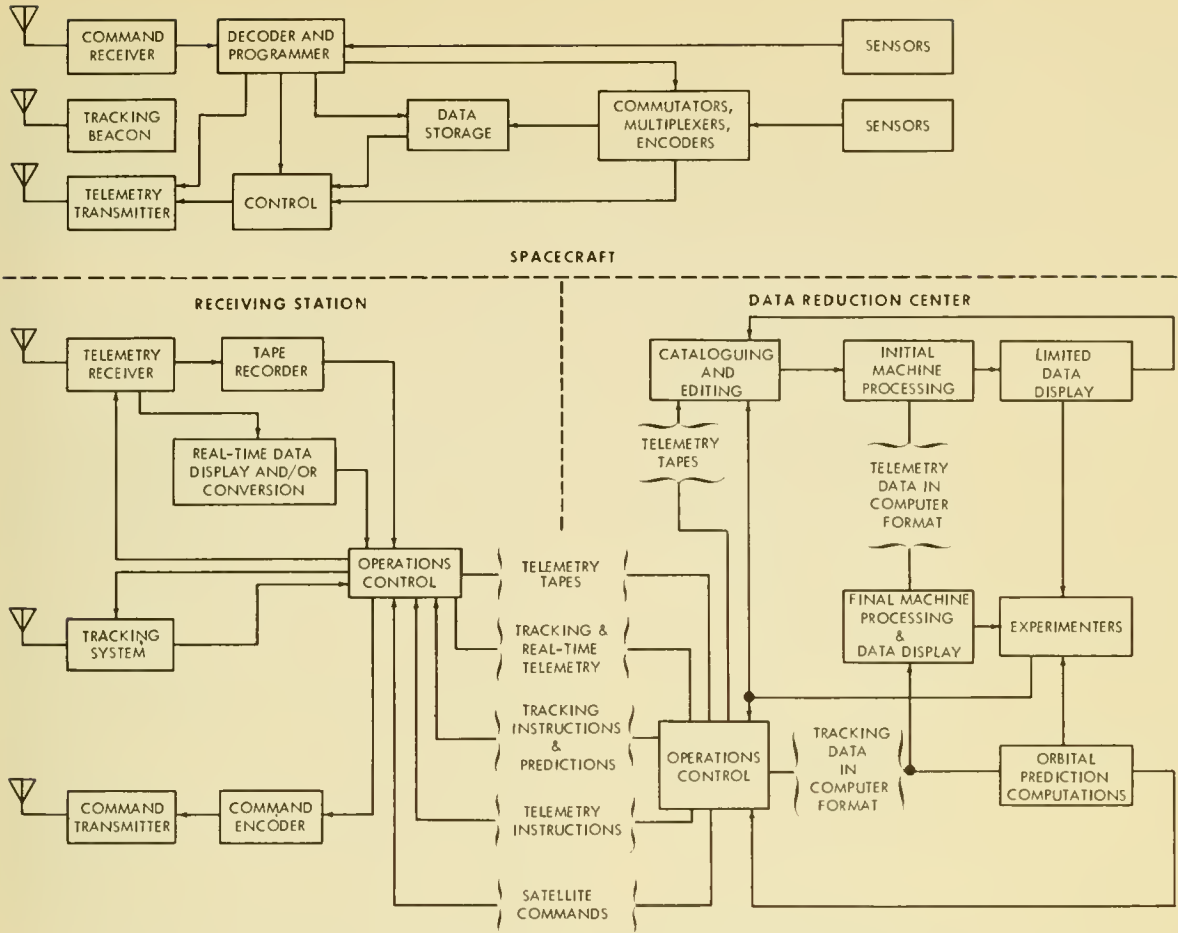

FIGURE 1-1. Flow diagram for operation of the Orbiting Geophysical Observatory in orbit.

cause the OGO's are basically self-controlling spacecraft, the *taped data plus Rosman real-time* approach will allow a large degree of control of EGO. For POGO, the real-time limitations are more severe. Even with data links from Rosman and Alaska to GSFC, real-time control of POGO may be limited to approximately 10 percent of the time. Teletype systems to all the other stations will allow preplanned commands from GSFC to be ready for transmission to the observatories when they come within range.

All data from the data acquisition stations will be recorded on tapes and forwarded to GSFC for processing. However, both GSFC and the primary sites will have PCM data handling equipment. At GSFC, this equipment will be used to condition wide-band PCM signals, received via the link from Rosman and

Alaska, for computer entry and display. Likewise, a special purpose processor will condition special purpose telemetry signals for entry and display. The computer will be used to perform automatic status checks on the spacecraft and to process, or refine, selected experiment outputs in real time. Control and display consoles at GSFC will be used for timing, routing, and display of the data, and for remote control of the ground recorders and PCM data handling equipment. Data such as time, station status, status of the observatory communications and data handling equipment, and the status of a "pass" will be displayed continuously. Hard-copy display of the status of the spacecraft (housekeeping data) and a *quick look* at selected experiment outputs will be provided by a printer. The tape recorders will be used to record the regenerated clean data from the out-

put of the signal conditioner, and the raw unprocessed signal from the special purpose telemetry. Time code will also be recorded simultaneously with these signals.

GSFC will also possess a command console that will allow central control to "talk" to the observatory in real time via the links to Rosman and Alaska. This capability will permit some automatic real-time response to events occurring in space. The primary stations also will have limited general purpose displays, together with their PCM data handling equipment. This equipment will provide station operators at these stations with sufficient quick-look capability for command verification, and will permit cleaner signals to be transmitted via the data link to GSFC. The result should be greater system flexibility and reliability.

Tracking data obtained from the network of Minitrack and primary and secondary stations will be forwarded to GSFC for computation of the orbital elements. Orbital predictions will be computed from these elements and will be transmitted to the tracking sites to provide antenna pointing information for the stations to allow initial antenna acquisition at the beginning of each pass.

Following transmission to GSFC of tapes on which the telemetry signals are recorded at the

remote sites, the tapes will be catalogued and processed. The general procedure will be to produce noise-free master computer tapes containing all raw data and orbital data. Individual computer magnetic tapes will be produced for each experimenter with the tapes containing his experimental data, spacecraft performance parameters, spacecraft orientation, orbital elements, and universal time. These tapes will be forwarded to each experimenter for further processing and analysis. The primary means for disseminating new information to the scientific and technological space community will be through publication in the open literature.

In summary, the Orbiting Geophysical Observatories are to be standardized, but flexible, spacecraft composed of easily removable subsystems and well-defined interfaces for experiments such that the OGO's should be capable of use for a wide variety of missions in a number of different orbits. Standardization and flexibility in removing, replacing, or modifying experiments have been keynotes in the design of a system whose design should serve as a carrier for experiments for several years. A systems approach to the observatory, the launch vehicle, and the tracking and data acquisition should result in fulfillment of both the primary and secondary objectives of the program.

2

THE ENGINEERING DESIGN OF THE ORBITING GEOPHYSICAL OBSERVATORIES

by

GEORGE E. GLEGHORN*

Space Technology Laboratories

The Orbiting Geophysical Observatory has been designed as a standard spacecraft capable of carrying a large number of varied scientific experiments on each launch. Margin built into the design makes the observatory capable of operation in a variety of orbits.

INTRODUCTION

The Orbiting Geophysical Observatory (OGO) is being developed by Space Technology Laboratories for Goddard Space Flight Center. The mission of the OGO has been described by Mr. Scull in the preceding paper.

The observatory may be considered to have two parts: a set of experiments, and a basic spacecraft. The *set of experiments* will be chosen on the basis of the mission of the particular launch, including such factors as the orbit, season of the year, availability of the experiment, and allowable weight based on launch vehicle capability. The *spacecraft* must be designed to accommodate a variety of experiments, up to fifty per launch, providing an attitude-stabilized platform with a proper mechanical and thermal environment, electric power, and provision for collecting the experimental data and transmitting it to the ground. The constraints within which the spacecraft must be designed are provided by the typical orbits of the inclined eccentric and polar orbits of the EGO and POGO missions and the characteristics of the Atlas, Thor, and Agena launch vehicles.

Particular needs of various types of experiments dictate certain specialized requirements for the OGO. Certain of the experiments

will be designed to look toward the earth or sun, while others will be required to be oriented directly away from these bodies. Other experiments must be oriented parallel to the plane of the orbit. The stabilization scheme provides for these needs throughout most of the orbit. In addition, the sensitivity of some experiment sensors makes it necessary to isolate them from all other portions of the observatory; this requires placing these experiments on long booms extending from the spacecraft's main body.

CONFIGURATION

The observatory is shown in the deployed configuration normal for orbital operation in Figure 2-1. The main box structure measures approximately 6 x 3 x 3 feet. Its size is limited by the necessity to fit within the 55-inch diameter of the nose fairing (Figure 2-2) as well as by weight restrictions.

One of the 3 x 6-foot faces is made to face the earth. Upon this and the 3 x 6-foot opposite face are mounted those experiments that are carried in the main body. A portion of the interior, 30 x 16 x 24 inches between these two faces, is kept clear of spacecraft equipment to provide for exceptionally large experiments. Most experiments mounted in the interior of the main body fit within one of the fifteen 8 x 8 x 8-inch mounting volumes provided on each of the doors.

The solar array is mounted in a shaft that passes through the two remaining large faces of the main body. Since the array must be maintained normal to the incident sunlight,

*OGO Program Director, Space Technology Laboratories, Inc.

THE OBSERVATORY GENERATION OF SATELLITES

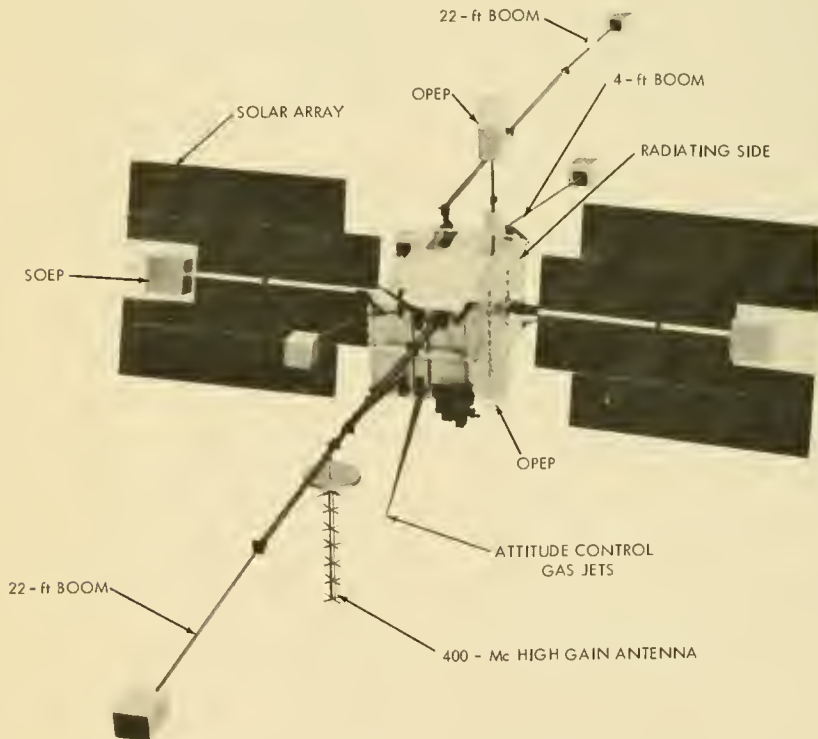
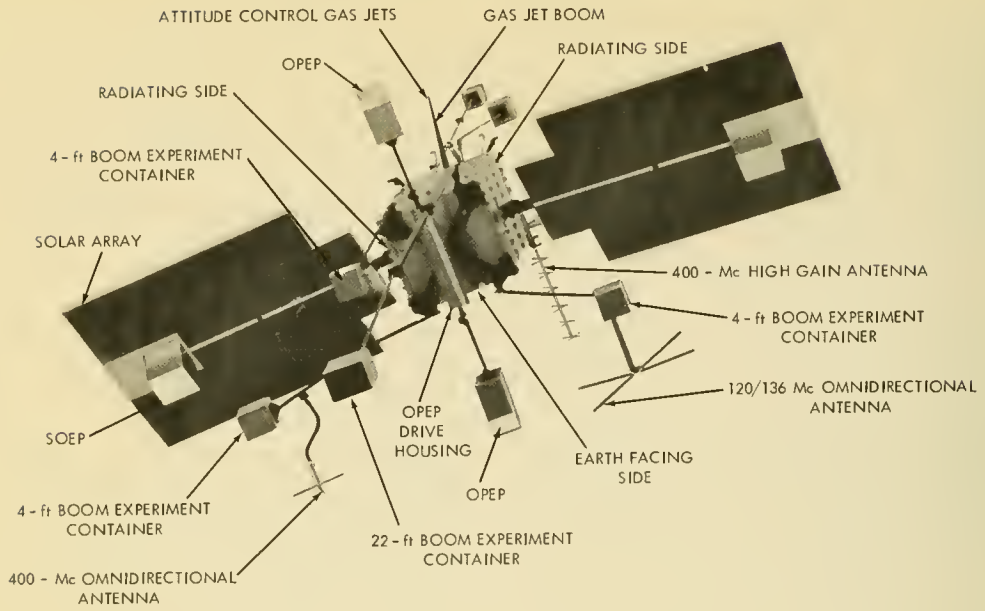

FIGURE 2-1. Deployed OGO.

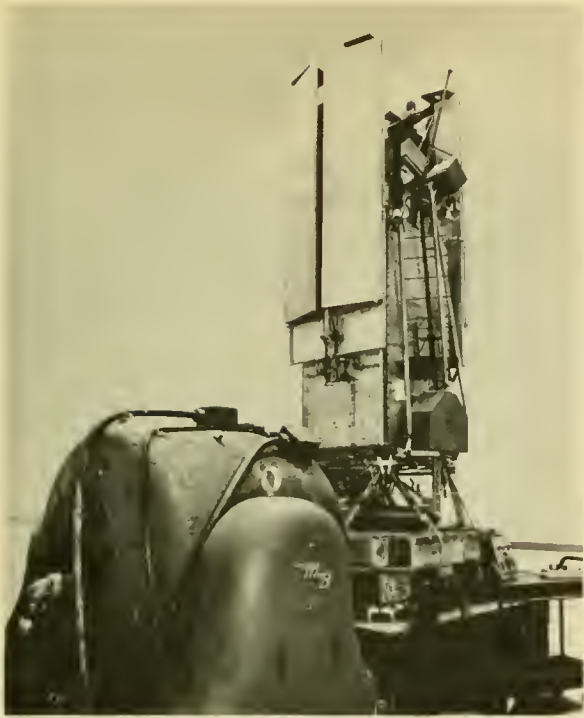

FIGURE 2-2. Lateral vibration survey test setup of folded OGO.

these two faces never see the sun and may therefore be used to radiate heat from the interior of the spacecraft. The amount of heat radiated is regulated by thermostatically controlled louvers mounted on these faces and on one end of the body, which also is never exposed to direct sunlight.

Electric power for the observatory is provided by silicon solar cells mounted on the solar arrays. Two *Solar Oriented Experiment Packages* (SOEP) for each array are provided for those experiments that must be oriented toward the sun.

Two booms, designed to accommodate experiments especially sensitive to the proximity of the spacecraft, are provided; each is 22 feet long. Four shorter experiment booms, 4 feet long, are provided for experiments whose sensitivity or look-angle requirements make mounting exterior to the spacecraft necessary. In addition, the tracking and telemetry antennas are mounted on booms to obtain proper antenna patterns and to remove them from the field of

view of the body-mounted experiments. Gas nozzles for the attitude control system are also mounted on booms to increase the lever arm and thus to minimize the weight of gas required.

At one end of the body, mounted on a shaft perpendicular to the solar array shaft, are two *Orbit Plane Experiment Packages* (OPEP). As the name implies, these packages are provided for experiments that must be mounted so as to face parallel to the plane of the orbit.

STRUCTURE

The main body of the spacecraft is a rectangular prism approximately 6 feet long by 3 feet square. The panels that form the sides are of a corrugated aluminum sandwich structure. This type of construction was chosen from among several alternatives as being the minimum-weight panel meeting requirements of stiffness, thermal conductivity, and ease of mounting experiments and spacecraft subsystems.

Two of the sides and the ends of the body are permanently fixed to each other. The remaining two sides are hinged in sections to permit access to the interior. Experiment assemblies carried in the main body of the observatory are mounted on these "experiment doors." The fixed faces and an intercostal structure attached between them provide mounting surfaces for the electronic assemblies of the spacecraft. Those assemblies that consume the most power are mounted on the fixed-side surfaces. These panels form an integral part of the thermal control system and serve to dissipate the heat by radiation.

The observatory is attached to the Agena boost vehicle by an interstage truss structure, which may be seen in Figure 2-2. The four inverted V's carry the load from the four machined feet attached to the observatory to the upper ring of the Agena.

The spacecraft and interstage are held together during boost by a tension band with four shoes that clamp the mounting feet to the mating interstage. Upon receipt of the separation signal from the Agena, explosive actuators release the tension band and allow four coil springs to impart a separation velocity of

5 ft/sec to the spacecraft. The design is such that the increment of angular velocity due to the separation process is less than 1 degree/sec under the most adverse conditions. Keeping this tumbling velocity small minimizes the job of the attitude control system in its initial orientation with respect to the earth and sun.

The structure is designed to be sufficiently strong to support not only the loads deriving from the 1000-pound spacecraft for the initial EGO and POGO missions but also to accommodate an additional 500 pounds for a growth version of the OGO. The most severe design restraint on the structure, however, is the vibration occurring during the boost phase of flight. In order that the spacecraft can be accommodated on the Agena launch vehicle, it must be folded to fit within the nose fairing; and in this configuration it must endure high vibration levels. The structural model spacecraft has been vibrated to 1.5 times the expected launch environment, leading to a number of design improvements in the methods of tying down the appendages and the solar panels.

The solar array (Figure 2-3) is constructed by attaching solar cell modules to a relatively light aluminum framework. To fit within the shroud, the paddles must be folded as in Figure 2-2. This results in a rather severe loading under the vibration conditions described above, and it is this loading that imposes the most severe restrictions on the solar array. Local stiffening of the framework near some of the holddown points has been necessary to hold the stresses within the allowable limits.

The deployment of the several appendages required for experiments and spacecraft equipment poses an interesting problem in design verification. Since the deployment in flight will occur under zero-G conditions, a number of special tests have been devised to confirm that the deployment mechanisms will work properly and that the stresses in the booms will remain within bounds. In a typical engineering test for one of the shorter booms (Figures 2-4, 2-5, and 2-6) the weight of the boom is supported by

a piece of elastic cord approximately ten times the length of the arm, fixed to a point directly above the hinge. This effectively cancels the



FIGURE 2-3. Solar array panel.

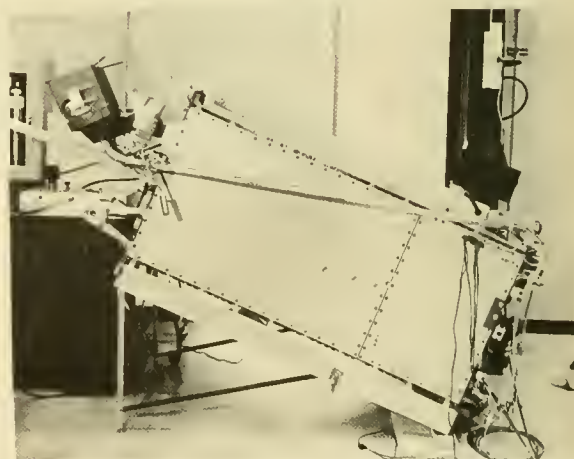

FIGURE 2-4. Short boom, deployment test experiment package no. 1, folded.

THERMAL CONTROL

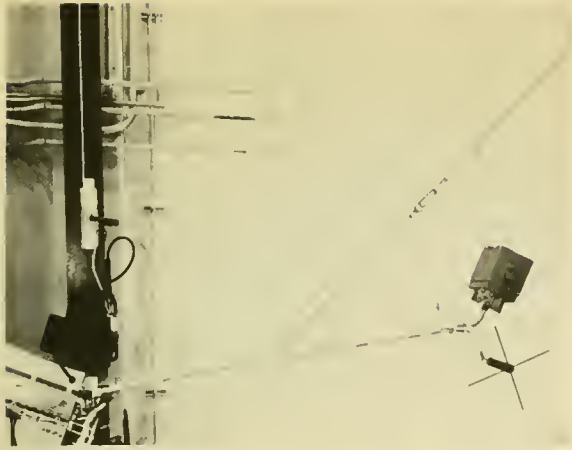

FIGURE 2-5. Short boom, deployment test experiment package no. 1, deployed.



FIGURE 2-6. Short booms, deployment test experiment package no. 1.

gravity force without adding to the forces tending to aid or retard the deployment motion. Tests of the longer booms have been conducted with the boom riding on air bearings on a special smooth floor of poured epoxy resin (Figure 2-7).



FIGURE 2-7. Long boom test setup.

The thermal control system has been designed to keep the interior temperature of the spacecraft's main body within the specified limits of 5° to 35° C. Since the OGO may encounter eclipses up to 2 hours in length or may be continuously in the sun for months at a time, it was found necessary to employ an active thermal control system to assure that these limits are met. This is accomplished by utilizing the fact that the two fixed faces of the main box through which the solar array shaft passes are never exposed to direct sunlight. Thus they may be used to radiate internally generated heat away from the spacecraft. The remaining faces of the spacecraft are covered with multiple layers of aluminized Mylar, providing a nearly perfect insulation. The amount of radiated heat is controlled by thermostatically controlled louvers (Figure 2-8). Each of these louvers

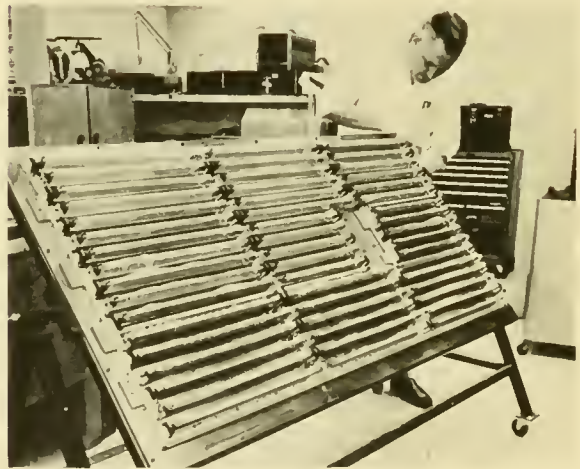

FIGURE 2-8. Thermal control louvers.

is actuated by a bimetallic spring used both to sense the temperature of the panel beneath it and to provide the necessary force to position the louver. Thus, when the internal temperature rises, the louvers are opened to allow more heat to radiate away. When the temperature drops, they are closed to contain it.

An early study was conducted to see whether the temperature could be controlled without insulating the surfaces exposed to solar radiation. The results indicated that it was not

possible to select the surface radiation properties to keep the temperatures within the specified limits.

It has been found that all the external experiment packages can be controlled by a proper balance of Mylar insulation and radiating surfaces with the use, in some cases, of thermostatically controlled heaters. The situation in these cases differs from the main body in that the sensors located in the external packages generate relatively little heat compared with the assembly within the main body. They can therefore be kept to a low enough temperature when in the sunlight by a proper balance of radiating and insulated surfaces, but must be heated during periods when they are in shadow.

The thermal control of the solar array must consider two separate aspects: keeping the temperature minimal when in full sunlight to maximize the efficiency of the solar cells, and minimizing the temperature drop during eclipse. It is necessary to keep the minimum temperature reached above -140°C to avoid damage to the solar cells because of the thermal stresses set up. This is accomplished by providing sufficient thermal mass in the beryllium substrates of the solar modules to keep above this temperature at the end of a 2-hour eclipse. It is this requirement, rather than a structural strength requirement, that determines the thickness of the substrate.

An electro-deposited optical coating is applied to the glass cover slides, 6 mils thick, mounted on each cell to attenuate radiation above the blue region of the spectrum. This minimizes absorption of radiation in the red region of the spectrum, which would tend to raise the temperature without materially adding to the electric power generated.

In addition to the cover slides, the back surface of the substrates is coated with a potassium silicate compound having a high emissivity and low absorptivity to maximize the heat radiated from the panel, Figure 2-9.

POWER SUPPLY

The power supply consists of three major elements: batteries, solar array, and charge reg-

ulating and power distribution equipment. The battery is connected directly to the main 28-volt bus, which is distributed throughout the

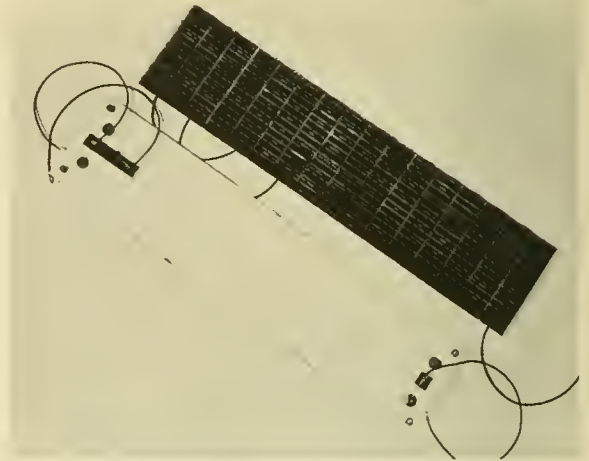

FIGURE 2-9. Solar cell modules.

spacecraft. Power for experiments and other units activated by command is switched in a Command Distribution Unit. Power for units requiring voltages other than 28 volts is provided by solid state converters. Converters are also used for those units for which the voltage regulation of the main bus (23.5 to 33.5 volts) is excessive. In addition, a 400-cycle converter is provided for the attitude control system.

Synchronization signals at 2461 cps are provided to all converters. Since VLF experiments will be carried on OGO, these signals are provided to assure that there will be bands of frequency in the VLF range that are free from noise generated by the power system.

Two nickel-cadmium battery packs, each of 12 amp-hr capacity, are used. Each battery consists of 22 prismatic cells and weighs about 32 pounds. To hold the upper temperature to a minimum, the batteries are mounted directly on the radiating face of the main body. Half of each battery pack (Figure 2-10) is electrically connected in series with half of the other pack, so that the heat to be dissipated from each battery will be equalized between the two radiating faces. The size of the battery

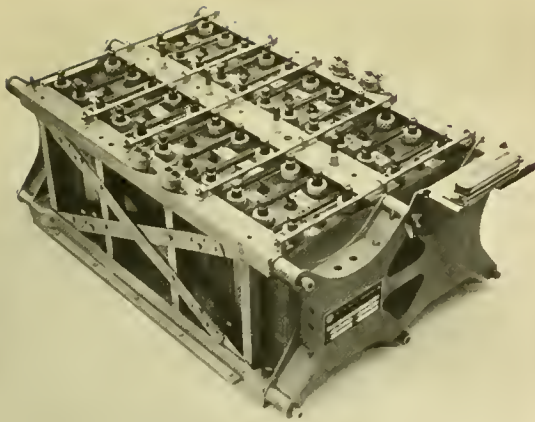

FIGURE 2-10. OGO battery pack.

has been selected to limit the depth of discharge during eclipse to 75 percent for the relatively infrequent 2-hour eclipse in the EGO mission. In the near-earth POGO orbit—with more frequent, shorter eclipses—the discharge will be limited to 25 percent.

The solar array consists of two solar paddles, each having 144 solar cell modules mounted on an aluminum frame. Each module contains 112 gridded silicon solar cells of 10.5 percent efficiency in space. The 7 x 16 cell module is wired in series parallel. The total array can provide approximately 500 watts, which is equivalent to approximately 7 watts/sq ft, or 4.8 watts/lb when beryllium substrates are used.

The charge control scheme incorporates two current regulators, each maintaining a preset charge current to one of the batteries. A functional diagram of the charge control scheme is shown in Figure 2-11. The charging current is controlled by shunting a portion of the array through power transistors and thus reducing the current available from the array. These transistors are mounted on heat sinks at the outboard ends of the array. When the array is cold after an eclipse, control of the charge current is lost, and the battery voltage and load set the operating point. Control is regained after the array warms up, which should occur within 10 minutes after leaving eclipse conditions.

The charge current rate may be chosen from one of several preset values by ground command. This allows the charge level to be selected to fit the particular sunlight eclipse conditions that the spacecraft experiences. Since the ratio of eclipse time to total orbit time is predictable long in advance, command changes need be made only at infrequent intervals. Various other sensors are provided to reduce the charge rate to a trickle charge level when the voltage reaches the proper level or when the battery temperature exceeds 95° F. When the battery temperature exceeds 125° F, indicating a battery failure, transfer relays operate to cause the remaining battery to control the entire solar array. Should both batteries fail, the system is caused to be operated directly from the solar array.

ATTITUDE CONTROL

The attitude control system serves to orient the spacecraft so that one experiment door faces the earth while the solar array is maintained perpendicular to the sun's rays. The local vertical is sensed by a body-mounted infrared horizon scanner, while the direction of the sun is indicated by solar sensors mounted on the tips of the solar panels. As shown by the block diagram of Figure 2-12, error signals from these sensors are used to drive reaction wheels that provide the necessary torques for stabilization. The same signals are applied in parallel to gas jets, with dead bands adjusted so that the pneumatics are used only for large errors. Thus the gas torques effectively serve to remove the secular momentum that may build up in the reaction wheels. The sun sensor signals are also used to control the drive mechanisms that cause the solar array to be oriented about its axis.

The pneumatic system uses argon stored at 3000 psi in a spherical titanium tank. Use of argon rather than nitrogen imposes a weight penalty of approximately 10 percent of the pneumatic system weight, but its use is nevertheless desirable because the lighter molecular weight of nitrogen would cause interference with certain experiments. The low pressure

gas, regulated to 50 psi, is piped to solenoid valves and thence to nozzles on the gas booms that provide 0.05 pound of force per nozzle.

The horizon scanner uses four tracking heads that are set with optical axes 90 degrees apart. These tracking heads track the edge of the earth, and the logic is such that the scanner determines the earth center when any three heads have locked on. If one of the three heads being used fails or if the sun appears in its field of view, the system automatically switches to the redundant tracker. A feature of the horizon scanner is that the scanning mirror located on each tracking head is mounted on flexure pivots, so that the need for bearings with their associ-

ated lubrication and sealing problems is eliminated.

The sun sensor system incorporates both coarse and fine sensors. The fine sensor is a silicon p-n radiation tracking transducer that provides two outputs proportional to the error signals about orthogonal axes and a third output indicating that the device is illuminated. In the normal mode of operation one of the proportional signals controls the vehicle about the yaw axis and the other signal controls the paddle rotation about its shaft. The third signal is used to switch the control inputs to the coarse sensors when the fine sensor is not illuminated. The coarse sensors are pre-irradiated

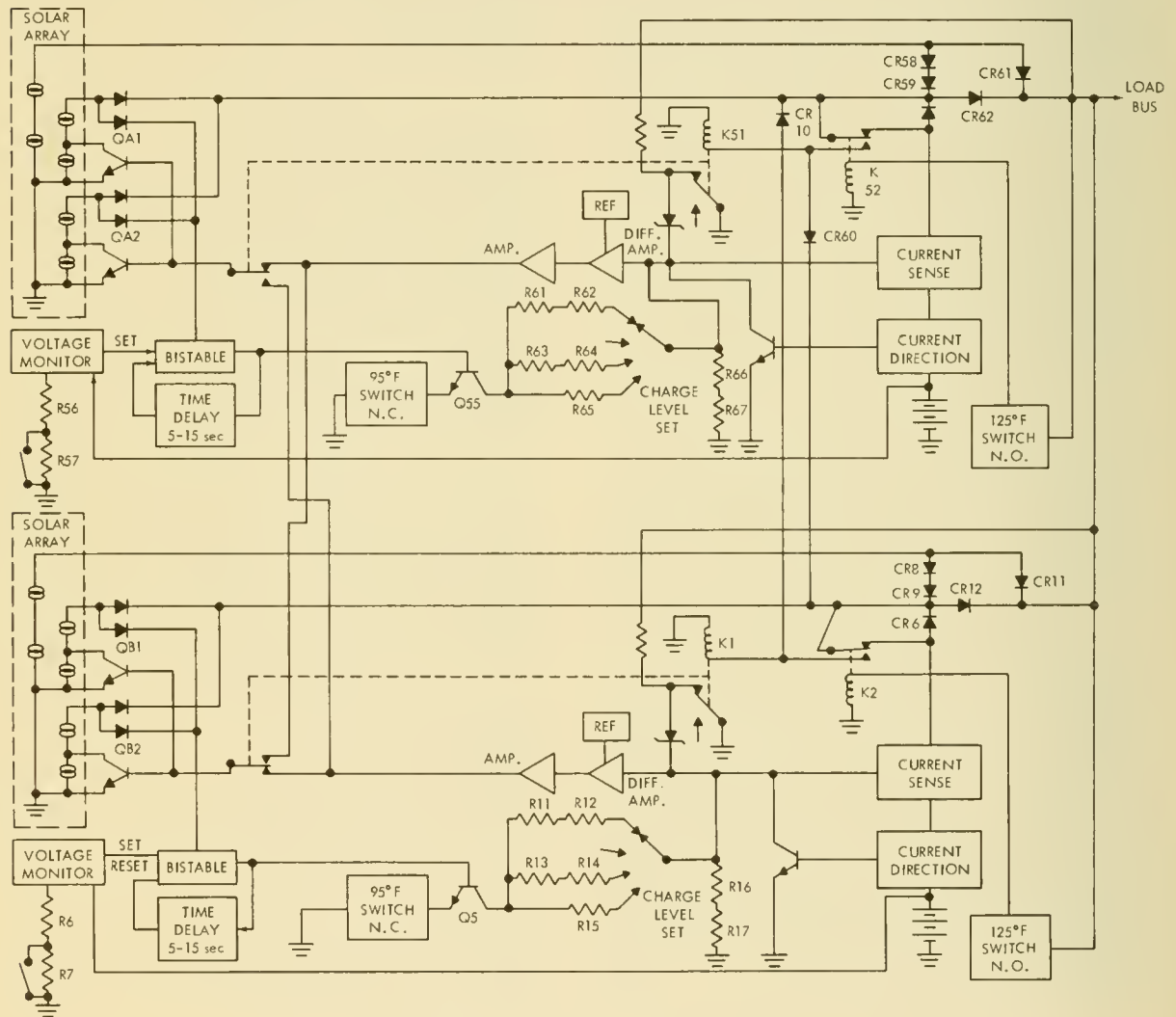

FIGURE 2-11. Charge control system.

silicon solar cells appropriately mounted and masked to sense the direction of incident sunlight.

The control system has three basic modes of operation: the launch/boost mode, the acquisition mode, and the normal control mode. The launch/boost mode is maintained until approximately 2 minutes after separation from the Agena vehicle. At that time, and after the appendages have been deployed, the system is switched into the first phase of the acquisition mode by the spacecraft sequencing equipment or by ground command. In the first phase of the acquisition mode, the paddles are caused to be slewed so that the solar cells face in the direction away from the OPEP end of the spacecraft. When this position has been reached, the array is held fixed with respect to the body, and the system enters the sun acquisition phase. In this phase the spacecraft is caused to acquire the sun operating from error signals

generated by the solar sensors. In addition, an angular rate about the pitch axis of approximately $1/2$ degree/sec is initiated. The sun is acquired (with output for rates of the Agena within specification) within 10 minutes. In addition to this, 15 minutes is allowed to assure that the momentum stored in the reaction wheels does not exceed the values required to enter into the next phase. The earth search phase of acquisition is initiated by a 29-minute timer that limits the duration of the sun acquisition phase. During this phase of operation the solar array remains locked on the sun, and the horizon scanner searches for proper lock on the earth. Because of the small pitch rate introduced and because of the geometry of the orbits, earth acquisition is obtained within one orbit period. When the earth is acquired, the system switches into the normal mode of operation. The system may be caused to return to the acquisition

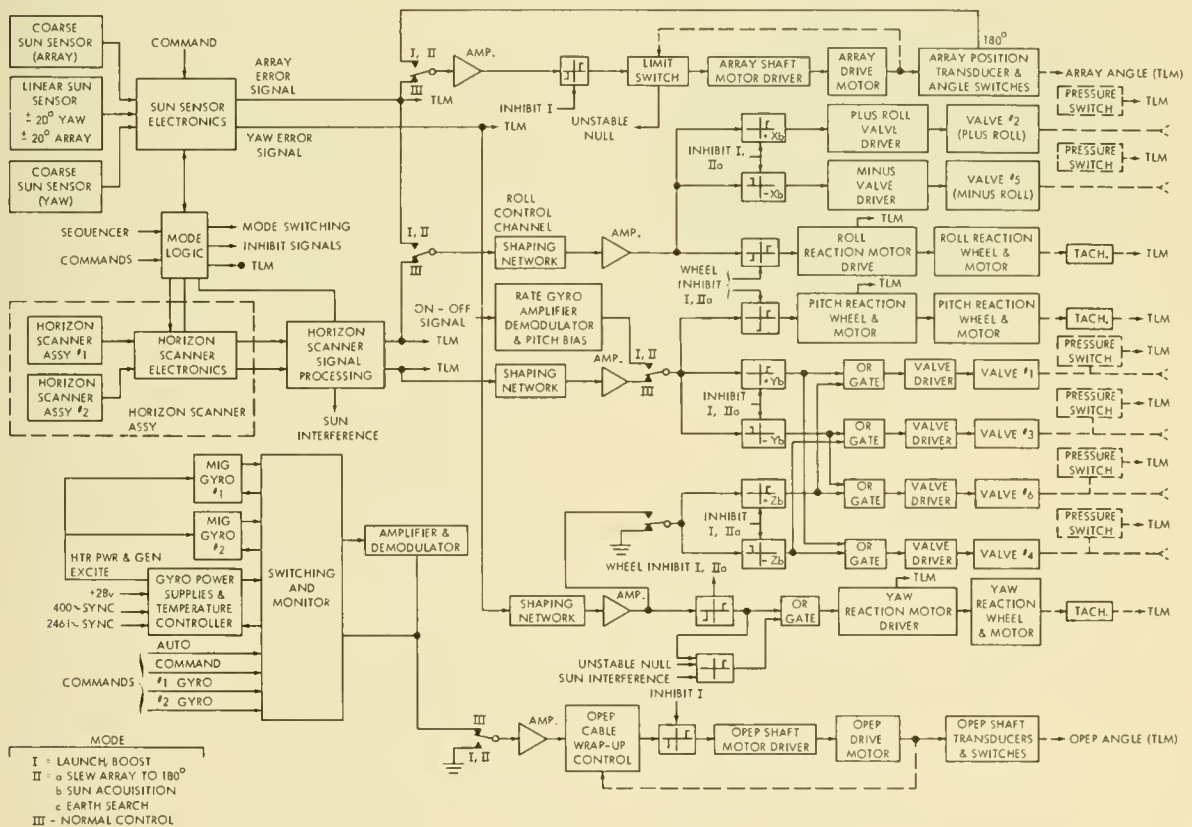

FIGURE 2-12. Attitude control system.

mode by ground command or when two or more horizon scanner heads are not tracking.

Control of the OPEP position is accomplished by a functionally separate control loop. It utilizes a single degree of freedom position gyro operating in a gyro-compassing mode. The output axis of this gyro is kept along the local vertical by action of the main body control system. The input axis detects the component of orbital rate when the OPEP is not properly aligned. The error signal operates a drive mechanism identical to the solar array drive mechanism to position the OPEP properly.

The drive mechanisms referred to have been developed for these space applications and feature a 24,000:1 gear reduction, with the final 100:1 reduction being made by wobble gear (Figure 2-13). The driving gear is made to

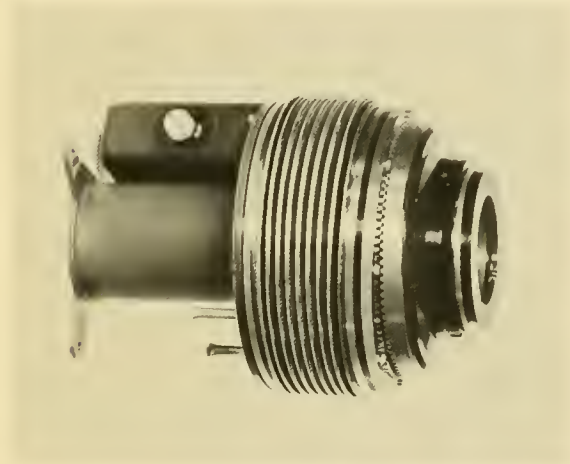

FIGURE 2-13. Wobble gear.

wobble without rotating by a cam internal to the bellows. The point of mesh is thus caused to move around the periphery of the gears, and the output gear is caused to advance by an amount proportional to the difference in the number of teeth between the driving gear and the output gear. The bellows fitted to the driving gear allows the high-speed gears to be hermetically sealed, eliminating the vacuum lubrication problem. The final gears are made of sintered bronze impregnated with molybdenum disulfide and can operate indefinitely

under hard vacuum conditions with no further lubrication.

COMMUNICATIONS AND DATA HANDLING

The communications and data handling system has been designed to provide for tracking and command functions for both spacecraft and experiments, and for telemetry for up to 50 experiments (Reference 1). The main telemetry system is a PCM system utilizing a 9-bit word and operating at three data rates (selected by command) ranging from 1000 to 64,000 bits/sec. The communication system, including antennas, must be capable of operating over the wide range of distances typified by the EGO and POGO orbits. As Figure 2-14 shows, some slight modifications—dependent on the orbits to be flown—are made to the communication system.

The tracking and command system is designed to be compatible with the NASA Minitrack Network as well as with the network of ground stations presently being constructed by Goddard Space Flight Center (GSFC). Both tracking transmitter and command receiver utilize the same omnidirectional antenna operating at a 120/136 Mc region. For the EGO mission, two 100-milliwatt transmitters are used for normal operation with a 10-watt transmitter being switched on for 45-second intervals when required for more accurate tracking. Two redundant AM command receivers are used. The outputs are cross-strapped to the several decoders. Failure detection features are built into the receivers to allow the gain of one receiver to be doubled should the other fail.

Two digital decoders will be used. Each has a separate address, but the outputs are combined in parallel so that command redundancy is assured. Each digital decoder is capable of receiving and decoding 254 commands. These commands are processed by a command distribution unit and are used to control experiments, to change the modes of operation of the attitude control system, etc. A tone decoder, with a capability of receiving up to 15 commands, is included. These commands may be utilized by the Minitrack Network or other stations that do not have equipment for sending digital com-

mands. It is expected that these commands will duplicate the more important commands of the digital decoders and thus provide more reliability through redundancy.

In addition to the 254 commands mentioned above, other commands that are supplied directly to the data handling system are available; this allows for operation of the flexible format feature.

The wide-band telemetry system is the major data handling system of the OGO. It is composed of two redundant data handling units that operate with outputs transmitted to earth in real time or connected to one of the two tape recorders provided for storing data. The basic telemetry format consists of 128 nine-bit words in the main frame. Of these words, 116 are available for experimental data; and the remaining 12 provide for synchronization words, an indication of accumulated time, three subcommutators, and an indication of the telem-

etry system's mode of operation. One of the 128-word subcommutators is used for experimental data; the other two are reserved for spacecraft operating and functional data. It is possible to command two special modes of operation to provide data at accelerated rates: One mode causes one of the spacecraft subcommutators to substitute for experimental data in the main frame; the other mode provides for replacing the normal main frame with one of 32 combinations of selected outputs from several experiments. By using the latter mode of operation, called *Flexible Format*, a subgroup of the experiments carried on a particular mission may be operated when phenomena of special interest occur.

The real-time telemetry may be run at 1000 to 64,000 bits/sec or at one intermediate rate selected for the particular mission. The tape recorders are capable of storing 43.2 million bits. Normal input rates are 1000 bits/sec for EGO

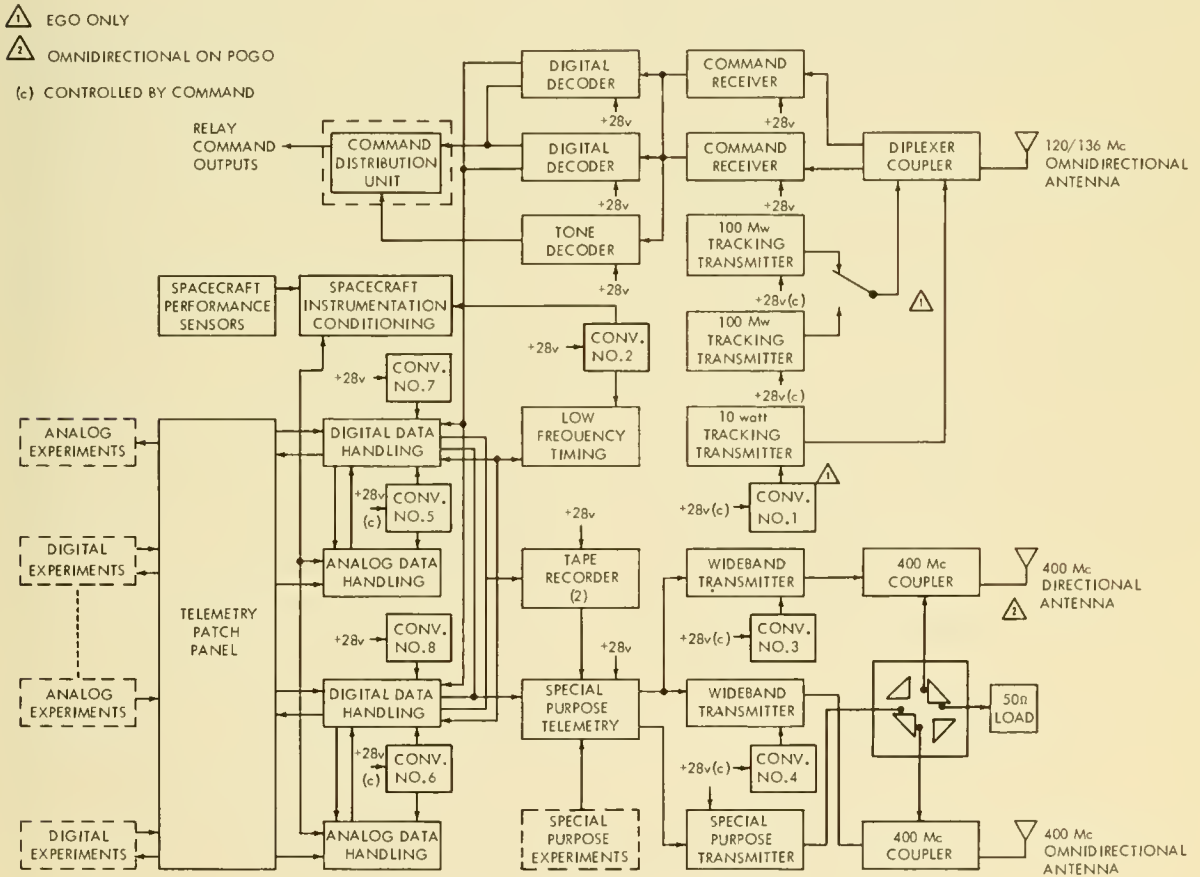

FIGURE 2-14. Communications system.

and 4000 bits/sec for POGO. The corresponding output rates are at 64,000 or 128,000 bits/sec.

Experiment data are routed to the telemetry system through a patch panel that allows assignment of digital and analog inputs to particular word positions. Provision may also be made easily for super commutation and cross-strapping between telemetry units.

In addition to generating the basic telemetry format, the timing units of the wide-band system provide all the basic timing within the observatory. The 2461-cps synchronizing signals for the converters are generated in these units, as is a set of timing signals decimally related to each other and ranging from a pulse every 100 seconds to 1000 pulses/sec.

The wide-band telemetry system can accept analog data that are preconditioned to lie between 0 and 5 volts. The data are routed via the patch panel to the input gates of the Analog Data Handling Units. These units sample the voltage as directed by the format generator and convert it to digital form with a quantization level of 20 millivolts.

There are two transmitters for the wide-band telemetry system, each capable of operating at an output of 4 watts at 400 Mc. Either transmitter can be commanded to transmit data over either the directional antenna or the omnidirectional antenna. The latter, providing an additional gain of 12 decibels, is intended to be used for EGO orbits.

A special purpose telemetry system capable of operating from an experiment whose output is an FM signal varying from 300 to 100,000 cps is provided. Two other modes of operation enable the transmission of data from up to five standard subcarrier oscillators, or transmission of the output of the wide-band telemetry system. The latter mode is expected to be used only in the event of failure of both 4-watt transmitters. The special purpose transmitter is rated at 1/2 watt at 400 Mc.

SYSTEM CHECKOUT AND TEST

The OGO has been designed to maximize the use of the spacecraft and telemetry system in

checkout and test, and to minimize the use of hardware connections to the spacecraft. Testing has been implemented by constructing a System Test Station, Figure 2-15, which serves



FIGURE 2-15. System test station.

as a complete telemetry and ground command station. The station is self-propelled and is designed for cross-country road travel or for loading into military transport aircraft. It is capable of communicating with the spacecraft over distances up to 10 miles, operating on its own transmitter. In addition to the van, several groups of equipment are used in the vicinity of the spacecraft to provide for battery charging, stimulating experiments or spacecraft subsystems, and the like.

The System Test Station in the van consists of an RF monitoring system, a command generator and transmitter, a tape and strip chart recorder, basic instrumentation, telemetry decoding and display equipment, and a semiautomatic test station. Recently a 4096-word storage digital computer was added by GSFC to process experimental data in real time in order to effect rapid checkout. All equipment may be operated from the operator's console, Figure 2-16, which also has data and status displays and is provided with windows through which the operator can observe the operations around the spacecraft on the test floor.



FIGURE 2-16. System test station operator's console.

The semiautomatic test equipment (SAT), Reference 2, enables test procedures to be car-

ried out rapidly and repeatedly. Test procedures are stored in punched paper tape that is read by a photoelectric tape reader. The equipment is capable of sending commands to the spacecraft and controlling the data decoding equipment to observe the results on the spacecraft of the receipt of the command. Data from the telemetry can be scrutinized to see that they fall within acceptable limits. Measurements may be taken at timed intervals to determine that the trend of data falls within proper limits. Use of the SAT enables efficient use of operating personnel and tends to minimize operator errors. At the same time the system is flexible. Test routines may be altered by interchanging the order of tests, by introducing diagnostic programs, or by punching a new program.

REFERENCES

1. GLASER, P. F., "The Orbiting Geophysical Observatory Communication and Data Handling Systems," in: *Proc. Nat. Telemetry Conf.*, Washington, May 1962, Vol. 2, Paper 3-3.
2. DAVIS, R. B., and WIGGINS, E. T., "Automation for Spacecraft Ground Support Equipment," in: *Proc. Nat. Aerospace Instrumentation Sympos.*, Washington, May 1962, Pittsburgh: Instrument Society of America (In press)

3

MISSION OF THE ADVANCED ORBITING SOLAR OBSERVATORY

by

JOHN C. LINDSAY*

Goddard Space Flight Center

The existence of life and activity on earth depends on solar energy. Interest in the sun is thus strongly motivated by an interest in the effects it produces on the earth, but it is also motivated by the fact that the sun is the only star we can hope to study at close range—an average star whose study is necessary to our understanding of other stars.

The study of the sun may be considered to have its beginning with Galileo, who, after constructing the first telescope in 1610 A.D., spent several years investigating the sun and sunspot behavior. The sun has been actively observed from that epoch to the present time. Now it is possible—through international cooperation under the auspices of the International Astronomical Union—for the sun to be kept under as nearly continuous observations as is possible from ground-based observatories.

With the advent of the *satellite* observatories, continuous observations are possible without concern for the restrictions of weather, seeing conditions, or suitable ground-based locations for an observatory—as is a problem in the Pacific Ocean region. Two possibilities exist for continuous solar observations from relatively low altitude satellites. They are: two satellites properly phased in near-equatorial orbits, or a single satellite in a retrograde full sunlit orbit. Satellite observations also have the advantage that they allow the optical resolution to be truly diffraction-limited, since there is no “shimmering” due to atmospheric turbulence and there is no scattering due to atmospheric

dust particles. Furthermore, satellites make it possible to study the vacuum ultraviolet, x-ray, and gamma ray radiations from the sun that are absorbed in the earth’s atmosphere.

FIRST ORBITING SOLAR OBSERVATORY (OSO I)

This new era in the study of the sun from above the opaque and turbulent sea of air—our atmosphere—truly began with the successful launching of the first Orbiting Solar Observatory (Figure 3-1) on March 7, 1962. Prior to

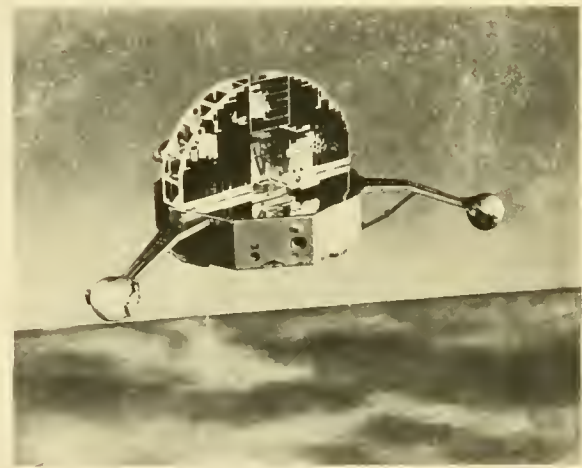

FIGURE 3-1. First Orbiting Solar Observatory (OSO I).

the launch of the OSO I spacecraft (1962 ζ 1), measurements of solar radiations that are absorbed in the atmosphere had been made from balloons, rockets, and rather simple earth satellites. As a result of the various restrictions imposed by these techniques, however, it was not

*AOSO Project Scientist, Goddard Space Flight Center.

possible to achieve a reasonable degree of continuity in these many spectral regions. This has now been accomplished by the OSO. The characteristics of the spacecraft that made this performance possible were the ability of the spacecraft to point instruments accurately at the sun, a circular orbit below most of the radiation belt but above the appreciable atmosphere, and a tape recorder data storage system that supplied practically complete orbit coverage (Reference 1). As an illustration, during the first three months of operation the spacecraft obtained over three times as much data in the 1 to 10A x-ray region as had previously been acquired, and over 4000 times the data previously acquired of the sun's spectrum from 50 to 400A. There were other measurements of x rays (20 to 100 kev) and gamma rays (100 kev to 3 Mev, and 50 to 300 Mev).

As an illustration of the type of data OSO I will provide, the 50 to 400A spectrometer data consist of three types: quiet sun data; data that represent the effect of solar activity, such as plage groups; and data arising as a result of a solar flare.* Enhancement of the spectra as a result of a flare is shown in Figure 3-2. As

*Private communication with Messrs. Neupert and Werner.

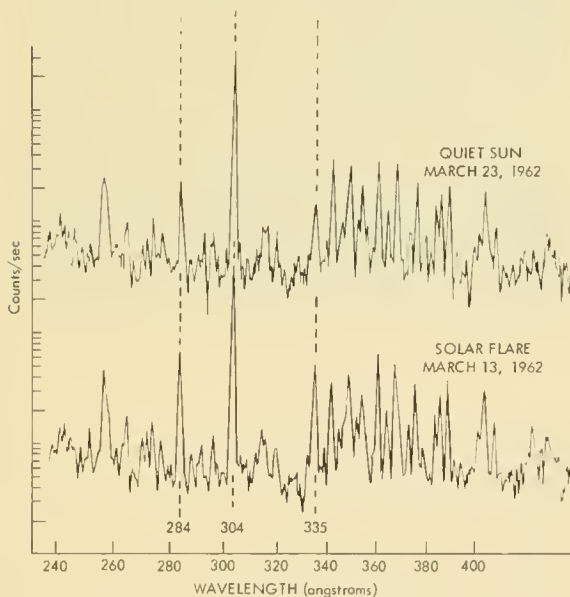

FIGURE 3-2. Spectrum of quiet and active sun.

can be seen, the 304 line is enhanced by approximately 30 percent, whereas the 284 line is increased by a factor of approximately 2.5.

In Figure 3-3, the variations in the solar coronal flux are shown and a comparison is made between the green coronal line and the Fe XV 284A line, as well as an Fe XVI 335A line. It can be seen that the correlation between these lines is reasonably good, showing that changes in the intensity of the 284A and 335A lines occur because of plage activity (non-flare condition) on the sun.

Information of this type is important not only to solar physicists but also to geophysicists who are interested in the effect of solar radiations on the ionosphere. It allows the geophysicist, in lieu of actual solar ultraviolet measurements, to draw reasonable conclusions as to variations in these ionizing radiations from knowledge of the solar activity indices, such as the green line of Fe XVI. In addition to the behavior pattern of these two spectral lines—of which we are just beginning to get a reasonable knowledge—there are over 100 lines in the spectral region to be analyzed, and an interpretation must be made concerning the data.

The advent of earth-orbiting laboratories as a tool for solar research had been looked forward to by many astronomers as one of the most important developments since the invention of the telescope. Although OSO I was an important step along the way, it would be untrue to assume that it represents the fulfillment of the solar astronomers' dream; for OSO I was limited in its capability. These restrictions were due to the rather limited pointing accuracy (1 arc minute in two axes), the limited space and weight available to perform pointed experiments (8 x 8 x 38 inches with a weight of less than 70 pounds), and the restricted orbit allowing only about 60 percent observation.

ADVANCED ORBITING SOLAR OBSERVATORY

What, then, is the mission of the Advanced Orbiting Solar Observatories?

It is nothing more than to provide the sophisticated spacecraft necessary to advance the study of the sun-earth relations and to study

the sun as a star from the vantage point of the spacecraft orbit. This is the general mission, and it is not possible to be much more specific. The reason for this is that a long delay exists between the concept of a spacecraft and the first launch. For example, the planning of the present OSO I was begun in February 1959, with the first launch occurring in March 1962. For the Advanced Orbiting Solar Observatory (Helios), the initial planning was done in the Spring of 1961—with the first launch, hopefully, in 1966. Thus, guessing what the solar physicist will need to observe in 1966 and on into the 1970's is the problem. As an illustration of the type of problems that scientists might attempt to study by using experiments on Helios, we shall consider the following aspects of solar flares:

1. The energy storage phenomena in the pre-flare active region.
2. The flare mechanism for energy release.
3. The manifestations of the energy release.
 - (a) Electromagnetic radiation.
 - (b) Particle flux.

4. Energy transport from the sun to the earth.

The Energy Storage Phenomena in the Pre-Flare Active Region

The most promising source for the flare energy is in the localized high-intensity magnetic fields associated with centers of activity. Severny has made observations appearing to establish that the origin of a flare is associated with the instability of these magnetic fields. His observations show changes in the field from *before to after* a flare; however, work at Mt. Wilson does not confirm these observations (Reference 2).

Magnetograms are now made at several ground-based observatories. However, one difficulty is that usually only one magnetogram can be made per day because of air turbulence. At present the magnetic fields of centers of activity can be measured only from ground-based observatories. However, with an improved spacecraft there may exist methods of making

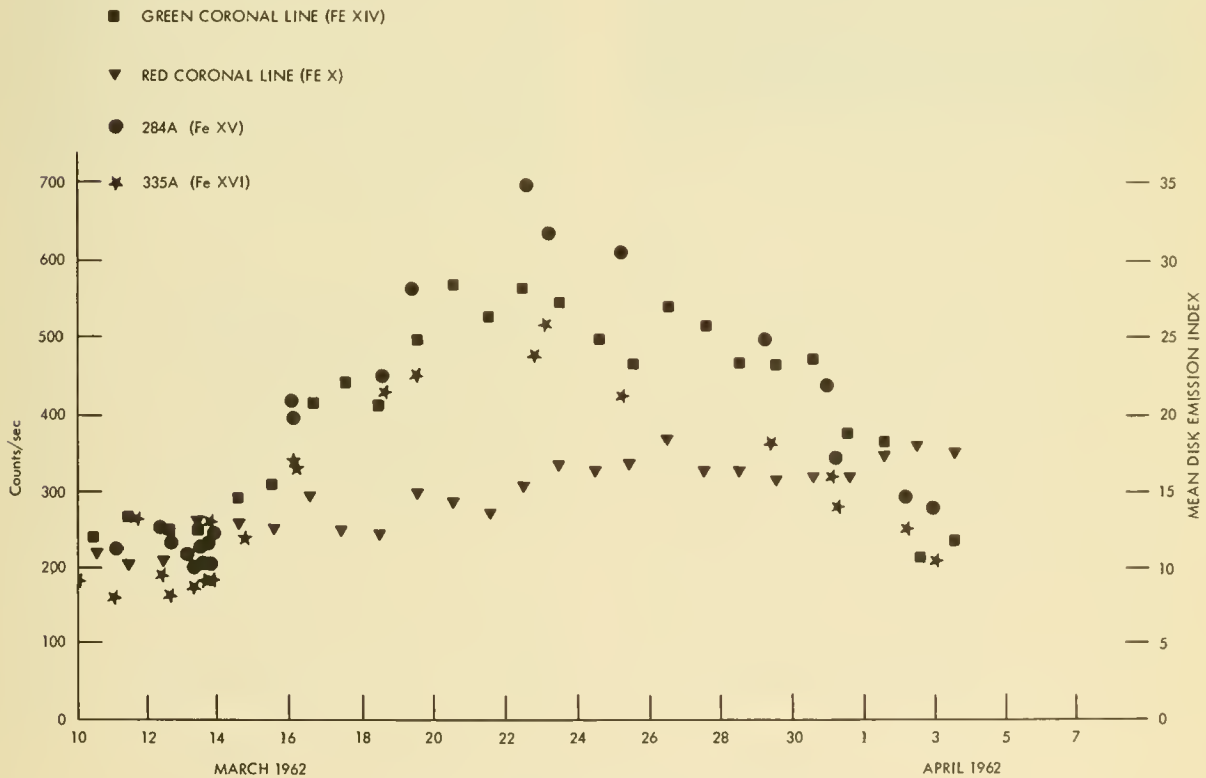

FIGURE 3-3. Variations of solar coronal flux.

superior magnetograms of the sun from *above* the atmosphere.

Observations at Mt. Wilson have shown that there is a striking correspondence between calcium-plage regions and magnetic fields, and it has been concluded that the close correspondence in most small structural details between calcium plages and the magnetic field indicated a real physical relation. Rocket spectroheliograms (Reference 3) of the hydrogen Lyman-alpha line show more contrast and are coarser than those obtained in calcium K or hydrogen alpha. The hydrogen Lyman-alpha is believed to originate higher in the chromosphere than hydrogen alpha, whereas calcium K originates lower down. With highly stabilized satellites it would be possible to study the growth and decay of centers of activity at various altitudes within the solar atmosphere by recorded spectroheliograms in selected vacuum ultraviolet and x-ray emission lines or wavelength bands.

The Flare Mechanism for Energy Release

Although the ideas of energy storage form a reasonable picture, much work is required to establish their validity and to extend the theories of flare phenomena. Various suggestions for explaining the flare mechanism have been proposed, based on ideas such as the building up of charge density with a subsequent electrical discharge, magnetic pinch effects, local changes in conductivity, the rate of change of the magnetic flux, etc. The presently favored idea is that the flare is connected with a collapse of the magnetic field. Since in the chromospheric-coronal plasma the lines of force are "frozen" into the matter, the matter collapses with the field. Under such conditions, ultraviolet and x-ray emission is enhanced.

Measurements of the vacuum ultraviolet and x-ray spectrum of radiation from a center of activity could be done from a spacecraft and would aid in determining the excitation temperature and electron density. This information will aid in understanding flare phenomena.

Manifestations of the Energy Release

The energy released from the sun during a flare is usually detected by observing the sun's electromagnetic radiations, either from ground observatories or from rocket and satellite observatories. In the visible region of the spectra the H alpha and calcium H and K lines are the most frequently used.

It is reasonable to expect that the ultraviolet lines of hydrogen, helium, and the lines of highly ionized iron observed from the orbiting solar observatories will add important new knowledge to the flare mechanism.

X-ray observations should lead to new knowledge concerning flares, and quite possibly will aid in unambiguously classifying flare types and sizes. G. Elwert has theoretically studied the generation of the vacuum ultraviolet and x-ray radiation of the sun. His results indicate that x rays of 10\AA and longer are emitted from the coronal of the quiet sun, whereas x rays from 0.1 to 10\AA are expected from lower in the solar atmosphere over active regions such as flares. The integrated x-ray flux below 8\AA at the earth's distance from the quiet sun is about 10^{-6} erg/cm²-sec. The intensity has been observed to increase by three to four orders of magnitude during flare activity. An improved spacecraft would make it possible to study the areas of origin of this flux on the sun.

Energy Transport from the Sun to the Earth

It is quite possible that all flares eject particles. However, such particles are not observed at the earth following every flare. It has been suggested by Gold that a magnetic tube guides the particles through interplanetary space, determining whether they impact the region of the earth. Optical measurements from a spacecraft have a good possibility of detecting these magnetic tubes, or *solar streamers*. The measurements would consist of observing the light scattered from the solar particles associated with the magnetic field. These streamers have been observed during eclipses; however, they are obscured by light scattered from the atmosphere during normal seeing.

By studying the requirements of these proposed measurements, some of the required spacecraft specifications can be formulated. For example, if spectroheliograms are to be made with sufficient resolution to follow the life of centers of activity, then 1-arc-second resolution will be ultimately required. To obtain reasonable size spectroheliogram images for use with a television camera aboard the spacecraft, provision for adequate focal length optics is required. (A 10-foot focal length will produce a 1.13-inch-diameter solar image.)

By following this procedure for the proposed measurements and other observations of interest, a set of preliminary specifications was prepared. This were presented to a group of interested astronomers at a meeting held for the purpose at the High Altitude Observatory in June 1961. As a result of these discussions, the concept for the Advanced Orbiting Solar Observatory (Helios) was finalized.

EXPERIMENT REQUIREMENTS FOR AOSO

The proposed Advanced Orbiting Solar Observatory (Figure 3-4) is a spacecraft about 10 feet long and 40 inches in diameter, weighing about 1000 pounds. Of this weight, 250 pounds is reserved for experiments occupying a cubic volume of more than 45 cubic feet. It will be possible to fly a 20-inch telescope, 10 feet long.

The long-term pointing accuracy is 5 arc seconds with a short-term jitter of no more than 0.5 arc second/second. On command, the spacecraft can be pointed at any spot on the sun. For forming images at wavelengths shorter than reflection optics allow, a line scan can be formed by scanning the spacecraft. Data storage capacity is 40 million bits. Power available for experiments is 75 watts. The orbit is polar retrograde full sunlit.

Further information concerning the spacecraft is included in the paper by Mr. A. J. Cervenka, to be presented next in this session.

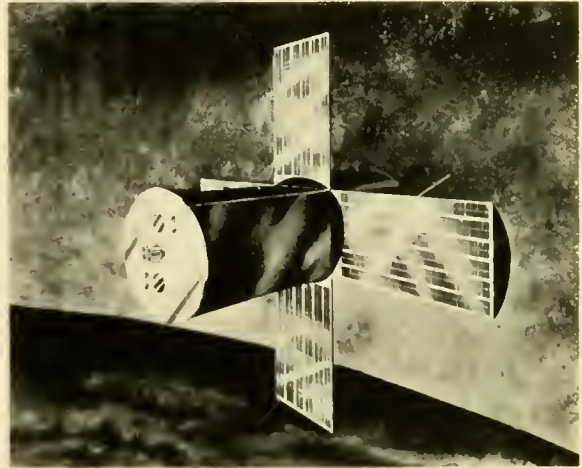

FIGURE 3-4. Artist's concept of Advanced Orbiting Solar Observatory (Helios).

REFERENCES

1. DOLDER, F. P., BARTOE, O. E., MERCURE, R. C., JR., GABLEHOUSE, R. II., and LINDSAY, J. C., "The Orbiting Solar Observatory Spacecraft," in: *Space Research III: Proc. 3rd Internat. Space Sci. Sympos., Washington, May 1962* (In press). Also in: Goddard Space Flight Center Contributions to the COSPAR Meeting May 1962, NASA Technical Note D-1669, 1963, pp. 213-221.
2. DE JAGER, C., "The Development of a Solar Centre of Activity," in: *Vistas in Astronomy*, ed. by A. Beer, New York: Pergamon Press, 1961, Vol. 4, pp. 167-168.
3. TOUSEY, R., "Solar Research from Rockets," *Science* 134 (3477): 441-448, August 18, 1961.

4

ONE APPROACH TO THE ENGINEERING DESIGN OF THE ADVANCED ORBITING SOLAR OBSERVATORY

by

ADOLPH J. CERVENKA *

Goddard Space Flight Center

The Advanced Orbiting Solar Observatory (AOSO) is being designed by NASA specifically for extensive and detailed studies of the sun. The field of view of this observatory will extend to a distance of about 10 sun diameters from the center of the disk; yet a 5-arc-second pointing precision permits some 400 separate observations in one pass across the sun's diameter. The AOSO can carry substantially heavier experiment payloads than the OSO, and its near-polar orbit provides these experiments with continuous sunlight for 9 months after launch.

This paper summarizes the design study conducted by NASA's Goddard Space Flight Center, in which emphasis was placed on stabilization and control of the spacecraft—a critical design area. In particular, sun tracker requirements were investigated in detail, and the conceptual design of a tracker produced in the study is described. The sun tracker work included experimental demonstrations of the feasibility and accuracy of GSFC's concept, and it appears that the ± 2 -arc-second accuracy required of a sun tracker can be attained. In the other subsystem areas, such as communications, data handling, and power supply, maximum use will be made of technology and hardware developed in the OGO, OAO, and other programs. The communications and data handling equipment being developed for OGO generally will satisfy AOSO requirements.

To meet the spacecraft design requirement of a 70-percent probability of a 1-year operational life, redundant components will be used extensively. This approach permits the use of readily available parts, but the initial spacecraft weight estimates exceed the payload capability of a Thor Agena launch vehicle. However, it is felt that this limit represents a reasonable weight goal; and studies to achieve it are continuing.

INTRODUCTION

The AOSO project is in its formative stage, and there are at present several design ap-

* AOSO Project Manager, Goddard Space Flight Center.

proaches from which to choose. Three of these approaches resulted from the NASA-funded design studies that were conducted by Ball Brothers Research Corporation, Space Technology Laboratories, and Republic Aviation Corporation. A fourth approach is the product of the Goddard Space Flight Center's (GSFC) in-house studies conducted over the past year. This paper is largely a summary of the in-house activities on this project.

The design objective most commonly associated with the AOSO is its ± 5 -arc-second pointing accuracy. For those working in the solar physics field, this objective has considerable significance, since it represents an order-of-magnitude improvement over the first generation of OSO's. For those who need a yardstick, 5 arc seconds is the angle a golf ball subtends at a distance of about 1 mile; or, at earth distance, 5 arc seconds represents over 2000 miles on the sun's surface. So, depending on whether we are looking for golf balls or sun spots, this accuracy appears to be either excellent or still rather coarse.

The angle of resolution will actually approach ± 1 second of arc, since jitter will be limited to that value; and the jitter rate will be limited to 0.5 arc second per second of time.

The ± 5 -arc-second pointing accuracy will be attainable over a 40-minute-of-arc square, centered on the sun's disk. It will have less pointing precision (± 1 arc minute) in the outlying areas, extending to a 10-arc-degree square. In addition, the spacecraft will be capable of providing raster scans anywhere within this 10-degree field. On command, a 40-arc-minute

raster scan having 120 lines (approximately 20-arc-second spacing) can be provided within 30 minutes of time for the complete frame. A 5-arc-minute raster scan can also be provided anywhere within the 40-arc-minute square centered on the sun. These pointing and scan capabilities are summarized in Figure 4-1.

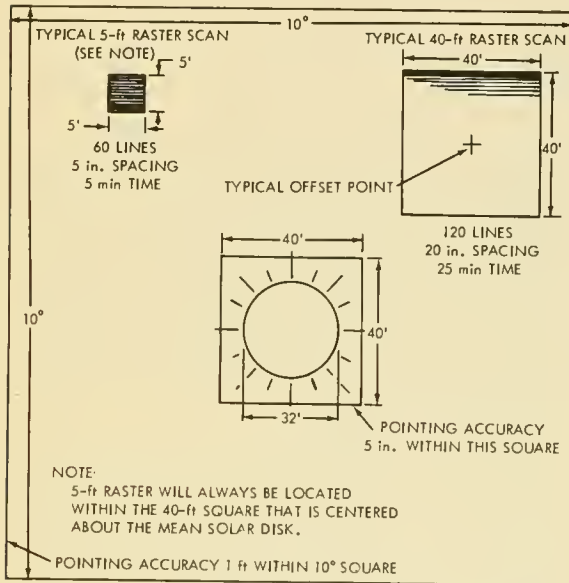

FIGURE 4-1. AOSO pointing and scanning pattern.

Some additional, although less dramatic, information regarding experiment capabilities is that the volume available to carry the experiments measures 37×37 inches normal to, and 60 inches in the direction of, the sun. Total experiment weight limit is 250 pounds.

A basic requirement of a solar observatory is that it see the sun during as much of its life as possible, since the large payload and accurate pointing capabilities of the AOSO are of no value during an eclipse. Therefore considerable attention was given to the selection of an orbit that would have a large proportion of full sun time. In this study, a range of orbital altitudes from 50 to 2500 nautical miles was considered. Inclination angles were computed for all the orbits investigated to give the ideal regression rate of 0.9856 degree/day. This regression rate is required to provide maximum time in sunlight for all times during the

year, and it is desired that the regression keep the line of nodes of the orbit perpendicular to the sunline. Expressions were developed to compute the amount of eclipse per orbit, and also the portion of a year the eclipsed orbits would occur.

Figure 4-2 presents the maximum amount of

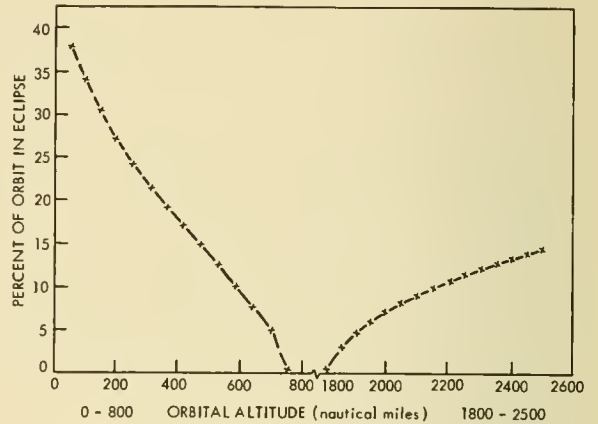

FIGURE 4-2. Percent of orbit in eclipse for circular orbits.

eclipse per orbit for various orbital altitudes that ideally could be obtained. Eclipse-free orbits begin at an altitude of 744 nautical miles and continue to 1813 nautical miles. At this altitude, eclipsed orbits begin again because of the decrease in the orbital inclination required to maintain the desired orbital regression rate.

The eclipse-free region between 744 and 1813 nautical miles would be selected if this were the only factor. However, considerations such as Van Allen belt radiation and reduced orbital payload capability at high altitudes led to the selection of a 300-nautical-mile orbit. At this altitude, the satellite will ideally experience 23-percent dark time during its most eclipsed orbit. Additional calculations for this altitude indicated that either of two launch times will result in orbits with no eclipse occurring for a maximum number of days following launch. These launch times are August 12 at 1400 GMT and February 6 at 0200 GMT. In either case the launch should be in a southwest direction from the Pacific Missile Range (PMR) in order to obtain an orbital inclination of 82.4 degrees.

The August 12 launch produces eclipsed orbits in the summer, and the February 6 launch produces eclipsed orbits in the winter. Either launch date will result in 267 days of orbits with full sunlight and 98 days of eclipse, the maximum eclipse time being 23 percent of the orbit period. These times do not include the effects of injection errors in launch time, inclination angle, and altitude. Examples of launch-time variations on the full-sunlight orbit are summarized in Table 4-1. The effects of other

TABLE 4-1

Effect of Launch-Time Variation on Orbit

Days After Optimum	Launch Window (min)	Effect of Launch Window	
		Days Lost For - Limit	Days Lost For + Limit
0	0.0 to +19.3	0	3.3
1	-9.0 to +26.4	0.6	5.7
2	-13.6 to +31.2	1.9	8.3
3	-18.4 to +36	3.1	11.1

errors were also estimated, particularly in terms of the maximum eclipse time per orbit that should be used as a spacecraft design criterion. These calculations showed that a 35-percent eclipse time could reasonably be expected, and this value was used in estimating spacecraft subsystem design requirements.

SPACECRAFT DESIGN REQUIREMENTS

The specifications for the AOSO have been described thus far mainly from a scientific instrument standpoint. In formulating these specifications, considerable attention was given to their engineering implications with regard to the launch vehicle and spacecraft requirements. The pointing and scan capabilities of the observatory generally define the stabilization and control system requirements. Some other requirements and restrictions used in the spacecraft design study are described in the following sections.

Launch Vehicle

The launch vehicle recommended as most desirable from a cost and reliability standpoint

is the Thor Agena. For a 300-nautical-mile polar orbit, the Thor Agena has a total payload capability of 946 pounds. Included in this weight are items such as adapters and separation devices. For a non-polar orbit, an additional weight penalty of 8 lb/degree retrograde would also be suffered. These items limit the actual payload capability to about 840 pounds for an 82.4-degree retrograde orbit.

The dimensional limitations imposed on the spacecraft are shown in Figure 4-3, which shows

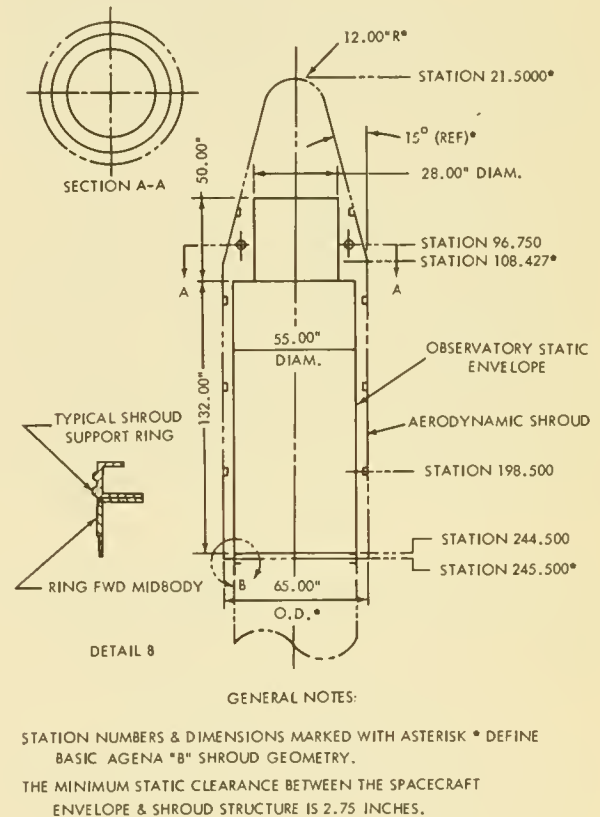

FIGURE 4-3. Observatory static envelope.

an outline of the Agena shroud and the spacecraft's maximum dimensions. The spacecraft diameter is limited to 55 inches and the length to 132 inches; however, an experiment could project an additional 50 inches forward into the conical portion of the shroud.

A summary of launch loads and motion assumed is as follows: acceleration aft, 8.6 g's; lateral, 2.0 g's; vibration, to 3.5 g's rms at a

maximum frequently of 3000 cps; shock values, to 5.5 g's. Sound pressure inside the shroud is assumed to reach 138 decibels.

The spacecraft residual motion rates at separation were assumed to be, in degrees per second:

- Pitch—0.1
- Yaw —0.05
- Roll —0.3

Tracking and Data Handling

It is assumed that the entire Minitrack network is available as a data-gathering system. Prime data-acquisition stations will be at the following locations: Rosman, North Carolina; Quito, Ecuador; Fairbanks, Alaska; Australia; South Africa; and Santiago, Chile.

The stations will have 40- or 85-foot antennas. Other equipment in a typical Minitrack station will include phase demodulation; diversity combination; PCM signal conditioning; *quick-look* equipment for FM/FM, PCM, and PFM station operational checks; and automatic-tracking antennas. When no project personnel are located at the station, then equipment unique to the project and necessary for satisfactory operation is also located in that area.

Reliability

The ground rule on reliability is that the spacecraft will have a predicted 70 percent or better reliability for an orbital operation of 1 year.

Experimental Data Capacity

The experimental data-storage capacity specified is 43.2×10^6 bits. Data handling equipment is to have the capability for either storage or real-time transmission as given in Table 4-2.

TABLE 4-2

Data Handling Equipment Capability

Source of Experimental Data	No. of Measurements	Word Length	Bit Rate (bits/sec)
Imaged-----	5	8	3800
Scanned-----	5	16	640
Non-scanned-----	15-2	8	200

SUBSYSTEMS DESIGN

The basic configuration approach as shown in Figure 4-4 consists of a spacecraft subsystems compartment, solar cell paddles, and the

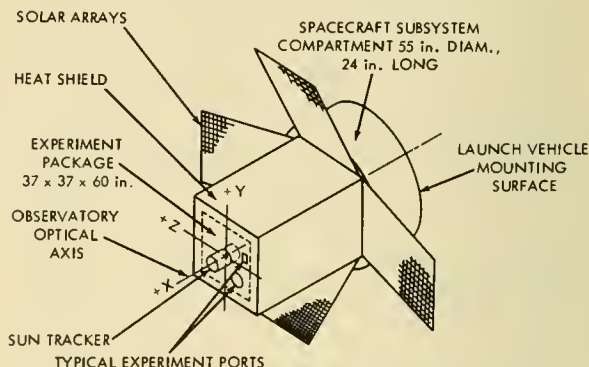

FIGURE 4-4. Conceptual configuration of AOSO.

experiment box. Not shown in the schematic is the transition section that connects the spacecraft to the Agena booster. In addition to transmitting the launch loads, this section also provides the dimensional transition from the 57-inch Agena support ring to the 55-inch spacecraft diameter.

A cylindrical spacecraft subsystems configuration was selected from structural, thermal, and volume considerations. For example, to minimize thermal control problems, it is desirable to mount all the subsystem components on one plate that will radiate heat directly to space. A circular or octagonal plate would provide the mounting surface required for all the subsystems within the 55-inch-diameter limitations. From a fabrication point of view, the circular plate and cylinder is simpler to produce and hence less expensive, and was therefore selected. The experiment compartment is shown as a rectangular box—since this is the shape given in the design study specification—and allows the solar arrays to be folded up around it during launch. The experiment package consists of a thermal shield, an experiment support structure, and the experiments. The thermal shield has apertures in the face normal to the solar radiation to admit the requisite radiation into the experiments and the fine sun tracker.

Structure

From the foregoing discussion, it is seen that part of the spacecraft structure is the subsystem mounting bulkhead and the cylindrical outside wall of the subsystem compartment. The addition of a second bulkhead between the subsystem compartment and the experiment package completes the structure. This second bulkhead is required to fulfill the requirement of experiment thermal isolation from the subsystem components and to provide a stable mounting platform for the experiment package.

The basic load-carrying structure within the proposed configuration of the spacecraft is conceived to be as follows:

Agency-to-observatory transition section: open truss structure

Subsystem compartment: reinforced monocoque circular shell with two reinforced metal honeycomb bulkheads

Experiment heat shield: reinforced monocoque

Experiment support structure: hollow metal honeycomb beam supported at the center of gravity

The entire structure will be fabricated from aluminum, or possibly magnesium alloys, because of the stringent weight problem imposed by the launch vehicle payload capability.

The evaluation of load paths starts with the eight Agena *hard points*. Eight load paths would enter the monocoque circular shell of the subsystem compartment, and it is proposed herein to combine adjacent pairs of load paths within the shell so that there are four load paths at the forward bulkhead of the subsystem compartment to provide support for the four corners of the experiment heat shield. The combining of load paths will require extra load-carrying members within the circular shell. The two bulkheads at either end of the compartment are basically circular flat plates that require stiffening. Both open truss and composite shear web beams were considered. Since all subsystem components are to be mounted on the aft bulkhead in a cantilever fashion, the extra plate-stiffening members are employed to secure the forward end of any component that requires it. The shell structure must have ap-

propriate coatings, materials, insulators, and thermal couplers so that the radial shell will be a good thermal radiator to space and a minimum absorber of thermal energy from external sources.

The basic design approach to the experiment package problem is to build an extremely rigid experiment support structure, to provide an isothermal environment for it, and then to mount all the elements with critical alignment requirements (experiments, sun tracker) to this structure. The function of the experiment package thermal shield is to provide an approximately isothermal environment for the experiments and sun tracker (on the experiment support structure) and to provide a floating structural attachment for the experiment support structure so that no structural distortions are transmitted to the rigid experiment support structure. The thermal shield has four load paths through it, one at each corner. The ideal structural attachment for the experiment support structure would seem to be three points at the center of the mass of the *experiment, support structure, sun tracker* assembly. This consideration may dictate that the experiment package configuration be cylindrical rather than rectangular. For the time being, it will be assumed that a four-point floating attachment can be conceived to attach directly to the four longitudinal load-carrying members in the thermal barrier, so that heat will not be transferred into the support structure by the thermal shield. Materials, coatings, and insulation used for the experiment support structure and thermal control must satisfy the following requirements: The external faces of the thermal shield must radiate thermal energy to space; the front face of the thermal shield must accept only the minimum amount of solar energy consistent with the efficient operation of the experiments and the sun tracker; the internal faces of the thermal shield must absorb radiated thermal energy from the experiments and the sun tracker, and transfer it adequately to the external surfaces; the experiments must be suitably coated and mounted so that the maximum amount of thermal energy is radiated and so that the assembly of experiment, support struc-

ture, and sun tracker will quickly reach and maintain thermal equilibrium even during periods of partial or full solar occultation.

Stabilization and Control

The purpose of the attitude stabilization and control subsystem is to provide the very precise pointing and scan capability required of the spacecraft. Various control concepts were investigated before the system shown in Figure 4-5 was evolved. The major components of this subsystem consist of a *sun tracker* to provide pitch and yaw information and *star trackers* for roll control. Control actuation is by means of three orthogonally mounted inertia wheels; momentum unloading of the wheels is performed with magnetic torque coils. During initial stabilization and acquisition control, actuation is provided by a cold gas jet system. Figure 4-5 indicates the normal flow of information, as well as possible backup modes of operation in the event of failure of one or more of the subsystem components. Although not shown in the diagram, redundant sun trackers are anticipated.

The operation of the control system can be illustrated by an examination of the component functions during the following control modes:

- Initial stabilization and acquisition
- Normal orientation
- Offset pointing
- Raster scanning
- Solar occultation and reacquisition

Initial Stabilization and Acquisition—The AOSO will be inserted in a 300-nautical-mile near-polar orbit, with possible residual tumbling rates being as high as 1 degree/sec about each axis. A time of one orbit period, approximately 96 minutes, has been allotted for initial detumbling and acquisition.

During the initial stabilization and acquisition mode, control system information is obtained from the rate-integrating gyros (in rate mode) and from the coarse sun sensor.

The feasibility of two methods of initial stabilization was studied. The first method utilizes magnetic torquing by means of reaction with the earth's magnetic field, and the second method involves torquing with a cold gas jet

system. In both cases, rate information is from a rate gyro mounted parallel to each control axis. Results of this study showed that magnetic torquing is not a feasible means for initial acquisition, owing to the large power requirements and long acquisition time. The cold gas jet system proved superior to the magnetic torquing, requiring only 0.05 pound of nitrogen and 13.2 seconds of time for acquisition.

Initial stabilization and acquisition are completed with the acquisition of stellar reference.

Normal Orientation—The normal orientation mode follows initial acquisition. The sun tracker and the reference star sensor signals control spacecraft orientation. During normal orientation, the optical axis of the observatory is pointed at the geometric center of the sun, and the control requirements are determined by the disturbance torques acting on the spacecraft. The momentum imparted to the observatory by these disturbances is transferred to the inertia wheels. It is estimated that the total momentum absorbed per orbit by the pitch, yaw, and roll axes wheels is 0.42, 0.005, and 0.0 ft-lb/sec respectively. The wheels can be unloaded on a continuous basis by magnetic torquing, but once per orbit would be sufficient because of the large momentum storage capability inherent in each wheel.

Offset Pointing—Offset pointing is the capability of directing the observatory optical axis to any position in a 10-degree square centered on the sun. Normal orientation is a special case of offset pointing where the offset position is zero. Slewing to any offset position will be accomplished by commanding the appropriate coordinates and rate-limiting the observatory motion.

Raster Scan Mode—The raster scan mode presents the most demanding requirements on the AOSO attitude control system. Problem areas arise in obtaining optimum torque to reverse the motion of the observatory at the completion of each scan line as well as in maintaining the desired 5-arc-second accuracy. The reference variable for the yaw control loop will be a digital saw tooth with rounded corners tailored to suit the specific system. Consideration of the yaw reference variable corner is important, be-

cause the torque applied for turnaround depends on the amount of momentum stored in the inertia wheel. By tailoring the reference variable and the inertia wheel motor characteristics, an efficient repeatable turnaround that is independent of the stored momentum can be achieved. The reference variable for the pitch-axis loop is a series of steps applied during yaw turnaround.

Roll-axis control is obtained with two single-gimbaled star trackers. The trackers are gimbaled about the observatory pitch axis and can retain the reference star in the field of view only by allowing the observatory to roll. A

single gimbal is used for increased reliability, and two trackers are required because any desirable reference star will be occultated at least once during an orbit. A correction prism is needed for one of the star trackers because two stars cannot be found that are exactly diametrically opposed.

Solar Occultation and Reacquisition—Analysis of the observatory launch and orbit shows that, with three-sigma insertion errors, 35 minutes of solar eclipse can be expected during some orbits for 3 months of the mission. During this time, drift due to external disturbances reaches such a magnitude as to preclude reacquisition

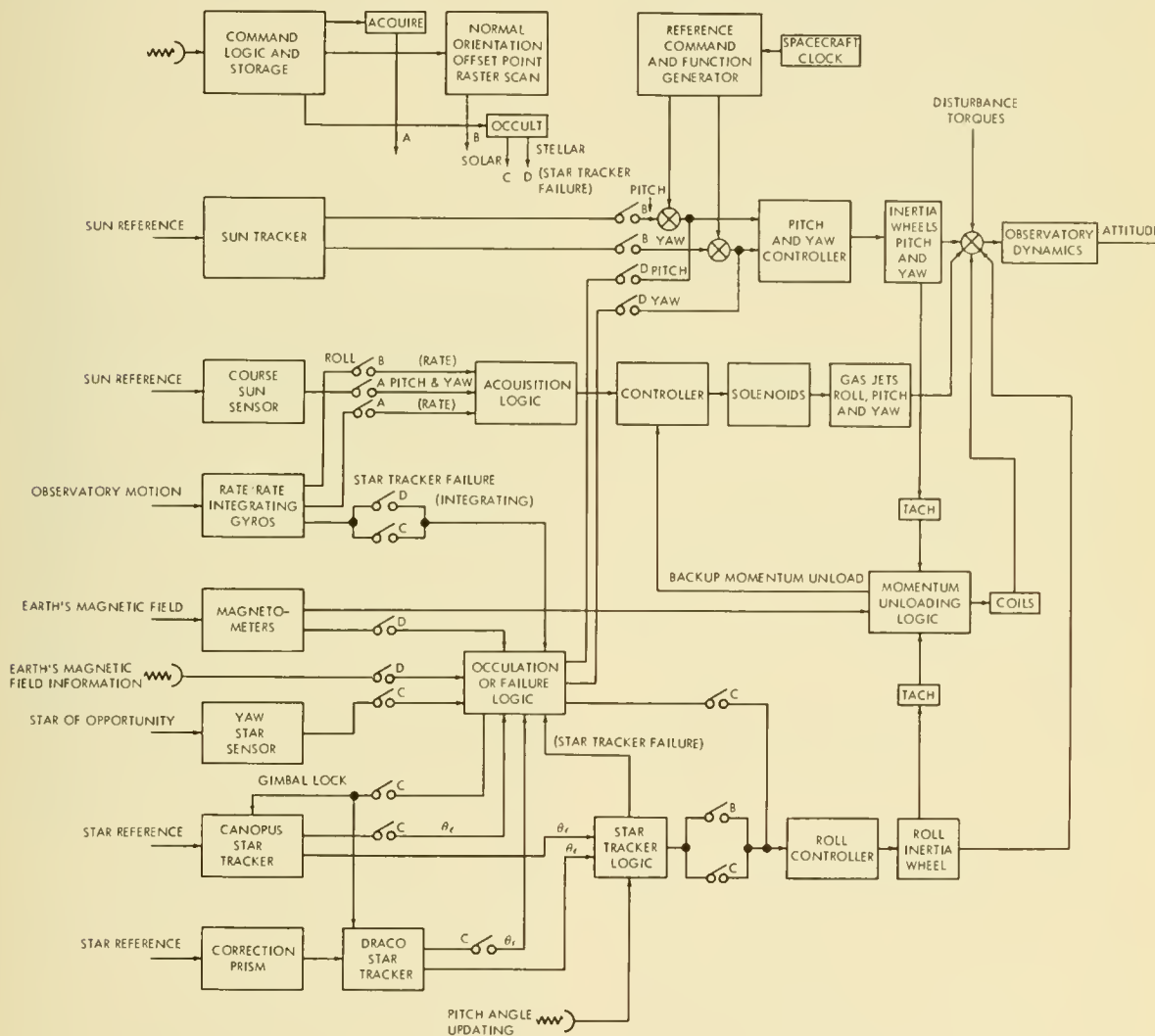

FIGURE 4-5. Stabilization and control subsystem.

in the specified time. Two sensors are available to provide attitude information for active control during solar occultation; a star tracker, and the yaw-star sensor. The yaw-star sensor is mounted so as to face in the opposite direction of the sun tracker. This sensor locks on a star of opportunity and, in conjunction with the star tracker, provides the necessary inertial reference. Rate/rate-integrating gyros in the integration mode can provide a backup. The yaw-star sensor was suggested by Space Technology Laboratories, Inc., one of the AOSO study contractors; and their studies indicated that, with the proper field of view, stellar lock-on will be accomplished before the observatory has drifted more than 6 degrees.

Sun Tracker—The AOSO sun tracker must have the following characteristics to fulfill its performance requirements:

1. A pointing accuracy of 1 to 2 seconds of arc when oriented within a 40-arc-minute square centered on the sun, and an accuracy of 1 minute of arc when outside of this square and inside a 10-degree square centered on the sun.
2. The capability to track on command within the above 10-degree square.
3. A tracking system bandpass of about 70 radians/sec.
4. Compatibility with a simple, reliable programming and command system.
5. A reliable and long-lived design.

Since it is recognized that the development of a sun tracker to meet these requirements would call for an extension of the state-of-the-art equivalent to that being attempted in the case of the OAO star tracker, a complete sun tracker study is beyond the scope and intent of this paper. However, the sun tracker problem in general and the specific GSFC tracker will be discussed.

Work on various approaches to sun tracker design led to the rotating-slab design, in which operation depends on the refraction of light through a slab of glass. If the index of refraction of the glass and its thickness are properly controlled, the angle of the light from the sun can be measured precisely by positioning the slab (see Figure 4-6). The slab is rotated until

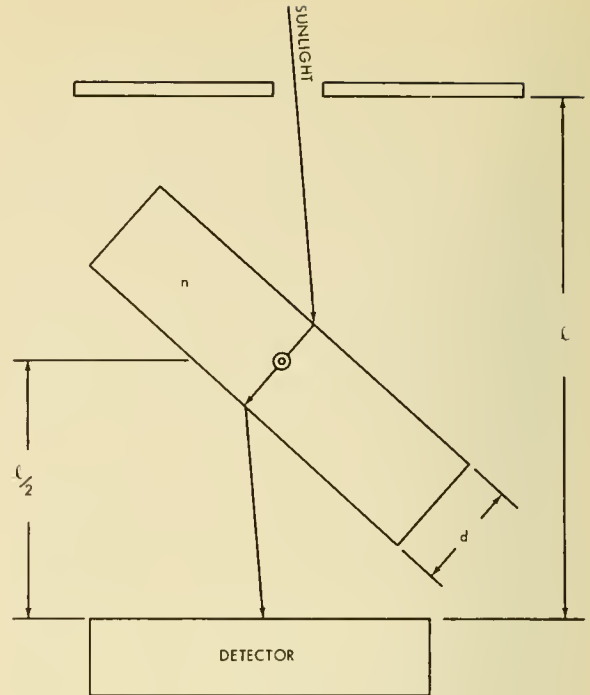

FIGURE 4-6. Rotating-slab sun tracker geometry.

the sunlight passing through the glass nulls a photosensitive detector. A 20-arc-second rotation of the slab corresponds to a 1-arc-second angle of incidence of the sunlight. An existing Baldwin digital encoder with an accuracy of 20 arc seconds will measure the slab position; this readout will be compared with the observatory reference variable to form the error signal for the control system. A servomotor will position the encoder and slab. The two units described above, one for the pitch and another for the yaw axis, comprise the tracker. An isometric view of the sun tracker is shown in Figure 4-7. A most important feature of this design is that the axes of the two slabs are orthogonal. This permits commanding the sun tracker in the same reference frame as the satellite and considerably reduces the complexity of the pointing command system.

During the process of studying sun trackers, it became apparent that many interface problems exist, one of which is the required compatibility between the tracker and the command logic or reference function generation. In considering the many sun trackers, it was noted that the command logic always reflected

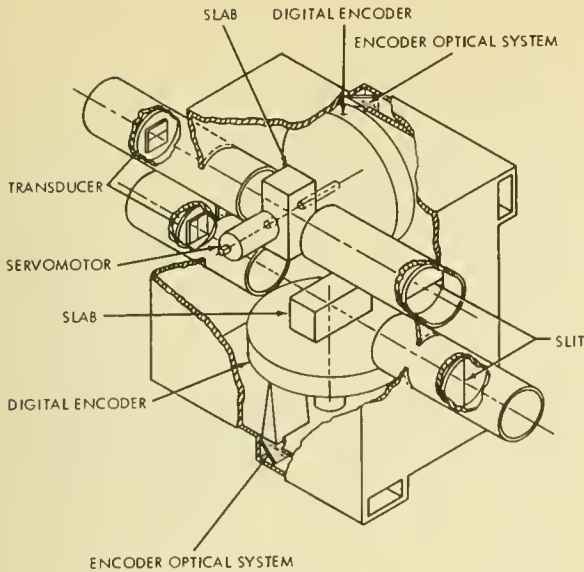

FIGURE 4-7. Goddard rotating-slab sun tracker.

the particular tracker design and is strongly dependent on it. Therefore, using a particular tracker infers using a particular command system. This is not a serious problem as long as it is recognized. Interface problems arise in sun tracker misalignment owing to structural deformations; calibration with experiments most likely will be required at selected intervals.

Communications and Data Handling Subsystem

The AOSO communications and data handling system includes a network of tracking and data acquisition, data reduction, and display facilities as well as the observatory electronic equipment. A complete evaluation of the functional, environmental, and operational requirements of this entire system is obviously beyond the scope of this paper, and only the observatory equipment portion will be discussed. The requirements of the AOSO communications and data handling subsystem are very similar to those of the OGO spacecraft; this similarity reduces the component design effort substantially. The major problem, then, is to integrate satisfactorily this subsystem with the stabilization and control subsystem and the experiment package system.

The communications and data handling subsystem of the AOSO will be described princi-

pally from a functional rather than design standpoint, and each major assembly will be considered separately. For purposes of discussion, the communications and data handling subsystem can be divided into four major assemblies

- Command assembly
- Wide-band telemetry assembly
- Narrow-band telemetry assembly
- Timing and synchronization assembly

Command Assembly—The command assembly of the subsystem is in essence the brain and nerve system of the observatory. The functions that it performs are as follows: (1) receives, decodes, stores, and/or executes ground commands; (2) programs experiments and controls subsystem telemetry; and (3) performs validation check on decoded commands. These functions are implemented as shown in Figure 4-8.

The desired instructions to the satellite are encoded and used to modulate a 2- to 5-kw command transmitter coupled to a directive high-gain antenna array. The intelligence is transmitted by PCM-FSK-AM modulation on the command carrier.

A brief description of a typical command will promote a better understanding of the operation of the command elements. For example, the instruction type of command message could contain two 32-bit words and their complements, sent at a rate of several hundred bits per second; the words contain bits devoted to word sync, spacecraft address, decoder ad-

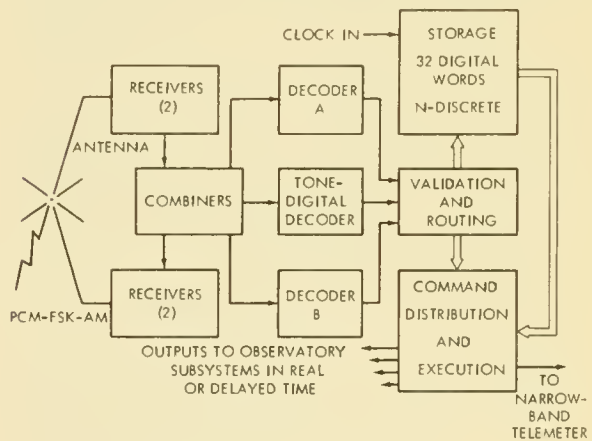

FIGURE 4-8. Command element.

dress, command instruction, and the time that it should be executed.

Following the reception of the signal by the spacecraft antenna, two pairs of dual receivers detect the signal. The structure of the command word then determines which of the two decoders is addressed. The selected decoder synchronously decodes the message and passes it into the validation and routing circuitry, where the word is compared with its complement bit-by-bit and a verification bit is simultaneously transmitted back to ground via the narrow-band telemetry. The routing circuit decides whether the command is to be immediately executed or is to be stored for execution at some future time. The command distribution unit determines what the instruction is and directs it to the proper destination.

Wide-band Telemetry Assembly—The most important assembly to the experimenter is probably the wide-band telemetry assembly, shown in Figure 4-9. The function of this assembly is to encode, format, store, and transmit data to the ground stations. Data can be sent in real time or from tape storage. The design requirements used for these components were made with the assumption that the following experiment and other information would have to be processed:

Item	No. of Measurements
Scanning experiments.....	5
Imaging experiments.....	5
Nonscanning experiments....	10-20
Experiment-related spacecraft.....	(Undetermined)
Other spacecraft status.....	(Undetermined)

The major elements in Figure 4-9 are shown in functional notation; those to the left of the dashed line represent the output termination of the various experiments. The upper block labeled "Experiments Shift Registers" represents the digital outputs of experiments of the types associated with the observatory's scanning mode of operation, although any data of compatible form may be presented in this category. The lower block represents those experi-

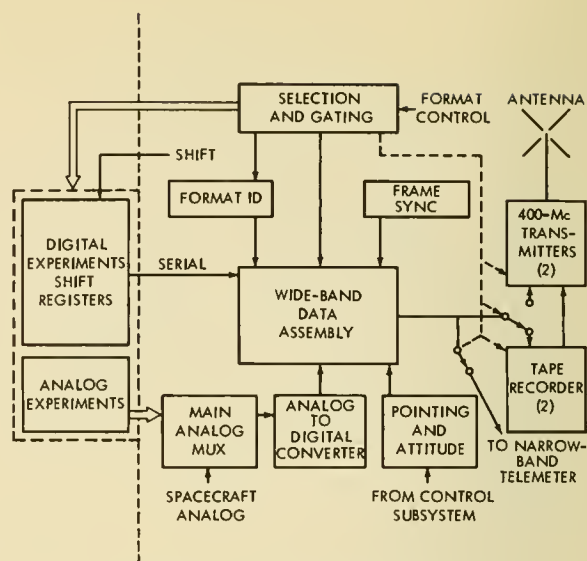

FIGURE 4-9. Wide-band telemetry.

ments that produce an analog (i.e., voltage or current, varying with time) output and that must be sampled in a predetermined way to provide the information in a more usable form for telemetering.

The various elements shown to the right of the dashed line comprise the wide-band telemetry assembly. The selection and gating matrix is the traffic control point. Its instructions are to a great extent pre-programmed prior to launch. After launch (satellite in orbit), modifications to these instructions—or new instructions—arrive from the execute section of the command assembly in either real time for immediate execution or for execution at a later time. It might be mentioned that this function, as well as all others shown, is synchronized with the spacecraft master clock (timing and synchronization assembly).

The data assembly unit accepts all data in digital form; inserts the selected format identification, frame sync words required for ground decommutation, pointing and attitude angle information; and forms a coded train of serial pulses containing the "bits" of information. This pulse train is then directed to one of several destinations, depending on the record length, orbital position of the observatory with respect to data-acquisition stations at the time,

and/or the relative loading of the two tape recorders. Which is to say, the data train may modulate the transmitter directly, or it may be channeled into one or the other of the two tape recorders to be read out by command when the observatory is in a more favorable position with respect to a data-acquisition station.

To retrieve stored data (approx. 20×10^6 bits per orbit), it is obvious that the tape recorder must be played back at considerably greater speed than used for recording. A nominal speedup ratio of 28 to 32 times appears feasible. This is an extreme simplification of the data retrieval problem, since several orbits may be made before interrogation is possible. It does, however, suffice to show the "appetite" of the observatory in information gathering and to show that the "digestion" of information is a much more complicated problem.

Narrow-band Telemetry Assembly—The narrow-band telemetry functions are more conventional in that they are similar to those performed on any large satellite in a near-polar orbit. These functions include commutation, encoding, and the format of experiment and spacecraft data whose rate varies from a fraction to several times the frame rate. The types of information include high-rate, high resolution spacecraft data; intermediate-rate experiment and control information; low-rate monitor; and *on-off* events. It also accepts command verification, monitors state-of-command storage, and transmits data in real time.

Figure 4-10 shows the arrangements of the functional units. The main narrow-band multiplexer commutates the "high-rate" spacecraft data. Experiment status and other medium-rate data are commutated at intermediate rate by a subcommutator. The slow-speed commutator, operating at a still lower synchronous speed, commutates such data points as temperatures, supply voltages, and other information of the so-called housekeeping variety. A fourth type of data, which is characterized by only two states, such as ON-OFF (switches, relays, gates, etc.), may be sent most efficiently by assigning a particular single bit to each of the points to be monitored.

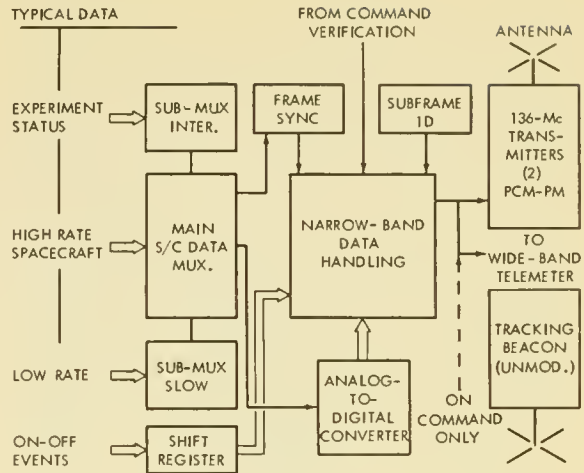

FIGURE 4-10. Narrow-band telemetry.

The narrow-band data handling unit, which has its counterpart in the wide-band element, formats all digital data, inserts frame sync code words, subframe identification, etc., and generates the serial PCM pulse train that phase-modulates one or the other of the two 136-Mc transmitters.

Timing and Synchronization Assembly—The timing and synchronization of operations aboard the spacecraft are of utmost importance. The timing assembly is conventional in design except for accuracy and reliability considerations. Two highly stabilized crystal oscillators drive a long binary divider chain. Output pulses are available at several rates, down to 1 pulse/sec and slower. Under control of the program matrices, the various pulse trains are gated to the other subsystems and subassemblies to assure synchronous operation and proper sequencing.

At least two oscillators are used to increase the reliability factor. For the same reason, a high order of redundancy is employed in the binary divider chain. Spacecraft time is also derived from the master clock.

Power Supply

The power supply subsystem provides the electric power requirements of the spacecraft and the solar experiments. Basically, it consists of silicon solar cell arrays, nickel-cadmium batteries, and charge control devices. During

the sunlight portion of the orbit, the solar arrays must have the capacity to supply all of the power requirements of the spacecraft plus an additional capacity for recharge of battery drain during eclipse, launch, and acquisition phases.

A block diagram of the power subsystem is shown in Figure 4-11. The estimated power requirements for the spacecraft are given in Table 4-3. This power is supplied at a nominal voltage of 28 volts with a range of 23.5 to 33.5 volts.

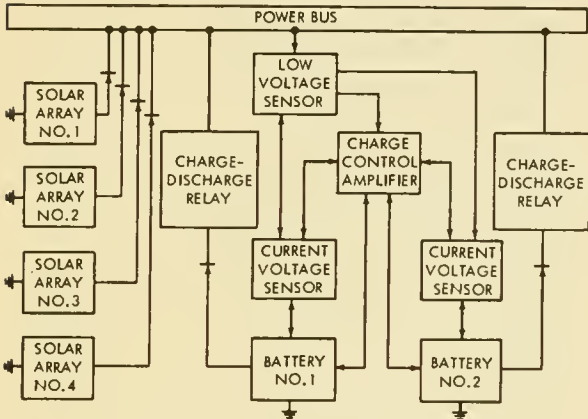

FIGURE 4-11. Power subsystem.

Design of n-on-p silicon solar cells must include consideration of cell degradation with time, as well as the effects of operating temperature on efficiency. Taking these various effects into account increases the equivalent initial design load (sunlight) to 550 watts. This would require an assembly of approximately 20,000 cells.

The capacity of the nickel-cadmium batteries is determined by the power required during the 35-minute eclipse time. Assuming a 25-percent depth of discharge limit for cyclic operation, a 12 amp-hr battery capacity is required.

The power controller acts as a voltage, current, and battery temperature sensor and controls these elements by limiting the charging rate and voltage within the prescribed limits.

Weight Estimate

Weights of the various subsystems described were estimated in a preliminary manner; and,

TABLE 4-3

Spacecraft Power Requirements

Requirement	Sunlight	Eclipse
Communication and data handling.....	51.6	51.6
Stabilization and control....	96.8	58.4
Power control.....	12.0	7.0
Solar physics experiments...	75.0	-----
Experiments programmer...	14.3	12.9
Battery recharge.....	152.0	-----
Diode losses.....	10.0	10.0
Cable losses.....	5.0	5.0
Total.....	416.7	144.9

for this reason, a total contingency of 45 pounds was added. These estimates, the payload, and other weight factors are shown in Table 4-4. The total weight estimate is seen to exceed the Thor Agena limit by some 70 pounds. Since this includes a known contingency of 45 pounds, the goal appears to be in sight.

TABLE 4-4

Payload Weight Estimate

Item	Weight (lb)
Stabilization and control subsystem...	140
Communications and data handling subsystem.....	154
Power supply subsystem.....	224
Experiments.....	250
Structure subsystem.....	125
Instrumentation.....	15
Observatory total (orbit).....	908
Retrograde penalty.....	64
Adapter, separation gear.....	45
Observatory total (launch).....	1017

Other mass properties of the observatory, such as inertia about the control axis, are as follows, in slug-ft²:

$$I_{roll} = 74.5$$

$$I_{pitch} = 137.5$$

$$I_{yaw} = 142$$

The products of inertia were found to be negligible.

CONCLUSIONS

The spacecraft design study conducted by the Goddard Space Flight Center has proved to be very helpful in pointing out problem areas that will require special attention during the development phase of the program. The sun tracker had been previously recognized as a key problem, but the study has shown that the integration of this component with the rest of the control subsystem, the structure, experiments, and the communications system is a problem of equal magnitude. On the other hand, progress on the sun tracker development has been very encouraging.

The design and development of the spacecraft subsystems do not appear to require technology beyond the state-of-the-art. The use of redundant parts to achieve the reliability goals will require further evaluation, since the current spacecraft weight estimates exceed the Thor Agena limit.

ACKNOWLEDGMENT

The author wishes to acknowledge and express his appreciation for the assistance received in the preparation of this paper from various AOSO project and functional support members of the GSFC staff.



THE MISSION OF THE ORBITING ASTRONOMICAL OBSERVATORY

by

ROBERT R. ZIEMER* AND JAMES E. KUPPERIAN, Jr. †

Goddard Space Flight Center

The basic objectives and the reasons for the development of the OAO project are discussed. The observing equipment now under development by the scientific community for the first three observatories is described, as well as a brief resumé of the specific scientific aims of each experimenter.

INTRODUCTION

The basic mission of the Orbiting Astronomical Observatory (OAO) is to extend man's knowledge of the origin and development of the universe. Beginning in the early seventeenth century, when the first practical optical instruments were used by Galileo, man has pursued the investigation of the universe by a constant study of the stars and planets. This early observational astronomy was essentially a study of the position and movement of celestial bodies. The work of Einstein revived the interest in, and study of, cosmology and gave to it an impetus that regained its prominent position in the physical sciences.

A further advance in astronomy resulted—during the early and middle 1800's—from the introduction of the spectroscope, which permitted the study of the visible energy of the sun. Not, however, until the application of photography to the study of celestial spectra, did the really rapid developments in astronomical spectroscopy occur.

For centuries, then, scientists have been seeking an understanding of the origin of the universe, handicapped by the obscuring and distorting curtain of the earth's atmosphere. Their observations were restricted to the small visible portion of the electromagnetic spectrum and, more recently, to the radio regions.

The advent of artificial earth satellites makes quite real the possibility of extending man's knowledge of the universe by observing above the earth's atmosphere and, for long periods of time, the energy from celestial matter in the ultraviolet and infrared regions of the electromagnetic spectrum. Additionally, the twinkling due to the earth's atmosphere would be eliminated; and the light of the night sky would no longer interfere with the detection of very faint objects.

These, then, are the basic reasons for the development of an orbiting observatory for astronomical purposes.

REQUIREMENTS AND PHILOSOPHY OF AN ASTRONOMICAL SATELLITE

The early efforts to place telescopes above the earth's atmosphere have utilized balloons (Reference 1) and, more recently, the Aerobee sounding rockets. The Aerobee, with its latest modifications, provides a tool for pointing observing equipment to five predetermined regions of the sky to an accuracy of $1\frac{1}{2}$ degrees of arc. Greater accuracies are possible with error sensors in the experiment packages. Some of the results of these experimental efforts are discussed by Dr. Kupperian (Reference 2) and Messrs. Stecker and Milligan (Reference 3). These early and limited observations have produced unexpected results in that the fluxes below 2400\AA of early-type stars are substantially less

*Project Manager, Orbiting Astronomical Observatory, Goddard Space Flight Center.

†Project Scientist, Orbiting Astronomical Observatory, Goddard Space Flight Center.

than theoretical predictions. The sounding rocket, although a valuable asset, still leaves much to be desired in the way of a remote-controlled observatory because of its limited payload capability and its short lifetime. The need of a long-life satellite capable of being pointed to any point in the celestial sphere is apparent.

In late 1958 and early 1959 several astronomers, Dr. Fred Whipple of the Smithsonian Astrophysical Observatory, Dr. Lyman Spitzer of Princeton University, Dr. Arthur Code of the University of Wisconsin, and Dr. Leo Goldberg of Harvard, proposed astronomical experiments for satellite application (References 4, 5, 6, and 7). As is the case with all space science efforts that are being supported by NASA, the astronomy program must be built on the participation of the scientific community. The success of a program such as the OAO hinges directly on the ingenuity and effort of the individual working scientists associated with the program.

About the same time, Dr. Kupperian presented the basic idea of a universal spacecraft or observatory to accommodate a variety of astronomical observing equipment. This concept was developed after examining the spacecraft requirements for a number of different experiment systems. The requirements for a stable platform, precise pointing capability, stable thermal environment, data storage, data transmission and command systems, and ground operation complex were common to all envisioned observing equipments. Thus the development of a spacecraft for one experiment system should in general satisfy the requirements for a large number of different systems.

Also, in the large engineering effort required to produce a space vehicle, a major portion of the expended work is in the initial design, development, and testing of the prototype or first model of the spacecraft. Here again an observatory that could be adapted, with only minimal changes, to a wide variety of observing equipment with many types of applications would amortize these high initial development costs. Increased reliability, maximum use of ground facilities, and operating experience

could be expected to yield dividends from the use of identical spacecrafts for a variety of missions. This idea, after many consultations with potential experimenters, finally culminated in a contract for a 3600-pound general purpose astronomical spacecraft with the Grumman Aircraft Engineering Corporation of Bethpage-Long Island, New York. The satellite was planned for an orbit that would be below the Van Allen radiation belts and yet high enough to minimize the external disturbance torques on the spacecraft so that precise stabilization and control could be achieved—an orbit of approximately 500-statute-mile altitude, inclined to the equator at 31 degrees.

OBSERVATORY SYSTEM

An artist's conception of the OAO is shown in Figure 5-1. A complete engineering summary of the design and development of the



FIGURE 5-1. Artist's concept of the Orbiting Astronomical Observatory.

spacecraft will be presented by Mr. Walter Scott in the next paper of this session. In planning a standard spacecraft to be used with minimal changes for various observing equipments, allowance was made to accommodate optics up to 40 inches in diameter in a system up to 10 feet long. This capability is provided in the central cavity of the spacecraft. Small secondary experiments weighing 10 to 20 pounds can also be accommodated in the top portion of the spacecraft. The spacecraft and astronom-

ical equipments are being designed with a goal of a 70-percent probability of a 1-year lifetime.

Electronic components and data handling packages for the experiments are housed in the shelves surrounding the central tube (see Figure 5-2). Here also are all the systems required for the operation of the spacecraft. Basically the spacecraft is designed to sense and point the optical axis of the telescope to any point in the celestial sphere, with the exception of a 90-degree cone about the sun line, to an accuracy of 1 minute of arc. Using the experimenter's prime optics and a suitable error sensor, the spacecraft control system is designed to achieve a fine pointing accuracy of 0.10 second of arc.



FIGURE 5-2. Compartment for housing experiment and spacecraft equipment.

The ground operation complex for the OAO will be centered at, and operated by, the Goddard Space Flight Center (GSFC). All commands and all reduction of scientific and spacecraft data will be accomplished at the Center. There will be remote receiving and transmitting stations at Rosman, North Carolina; Quito, Ecuador; and Santiago, Chile. With this net or fence, one contact per orbit of at least 5 minutes duration is possible at altitudes as low as 350 statute miles. Commands generated prior to a contact will be transmitted from GSFC by teletype to the appropriate remote station, and related data received at the remote stations will be transmitted by the same method

back to GSFC. The bulk of the scientific data will be sent to GSFC, by air mail, for reduction.

EXPERIMENT SYSTEMS

The primary experiments for the first three observatories have been selected and will be directed toward the study of the ultraviolet portion of the spectrum. The first flight will carry the sky survey experiment of the Smithsonian Astrophysical Observatory (SAO) and the broad-band photometry experiment of the University of Wisconsin. The second observatory will contain a system for the study of absolute spectrophotometry being prepared by the Goddard Space Flight Center. The third unit will carry the Princeton University equipment intended for the study of interstellar matter.

Since the first observatory will carry equipment intended primarily for survey studies, it is intended that the data obtained provide direction and interesting focal points for the experiments that follow. Since there is always an element of uncertainty in the flight of a new system, the requirements of the stabilization and control system are less stringent for these first experiments than for those following.

A brief glimpse of the objectives and basic elements of the observing systems now being prepared might be of interest. All the experimenters are implementing the development of their systems by means of contracts with various industrial organizations. The first spacecraft, because of the physical size and multiplicity of telescopes, is altered from the basic configuration to allow experiments to view from both ends (see Figure 5-3). The SAO experiment, consisting of four instruments, views from the lower end of the spacecraft; and the Wisconsin experiment, consisting of seven optical systems, is pointed forward. These two experiments were chosen for the first flight primarily for the following reasons: (1) They are of a survey and exploratory nature; (2) the Wisconsin equipment has the capability for obtaining more detailed information on "finds" resulting from the SAO sky survey; (3) they make complementary demands on the spacecraft capabilities with regard to telemetry, and real-time and remote operation; and, finally,

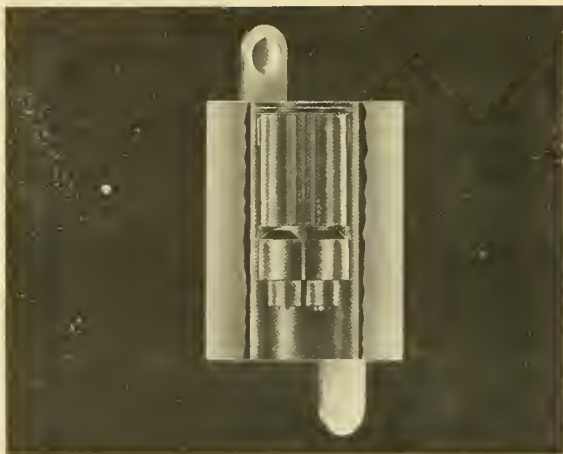

FIGURE 5-3. OAO spacecraft no. 1.

(4) the systems are compatible with the physical space available for the experimental equipment.

Smithsonian Astrophysical Observatory Experiment

The primary objective of the Smithsonian experiment, called Project Telescope, is to make a new map of the sky similar in coverage to sky surveys such as the Draper Catalog and the Palomar Sky Atlas. This new map will differ from its predecessors, since it will be made entirely in the ultraviolet portion of the spectrum. This map will include stars to the 7th or 8th magnitude and large nebulae to the 8th magnitude per minute of arc. It is planned to measure up to 50,000 main-sequence stars in four ultraviolet spectral bands: 1200 to 1600Å, 1300 to 1600Å, 1600 to 2900Å, and 2300 to 2900Å. These four ultraviolet readings for each star will be used to determine the shape of the spectral energy distribution curves.

The experiment consists of four electronically recording telescope cameras serving as broad-band photometers. As shown in Figure 5-4, each telescope uses the Schwarzschild optics with the ultraviolet detector at the focal plane. The mirrors are made of fused quartz. The primary ring-shaped mirror has a clear aperture of 12 inches, with the central perforation being 5 inches in diameter. The secondary mirror has a clear aperture of about 6 inches, with a central hole for the calibration system

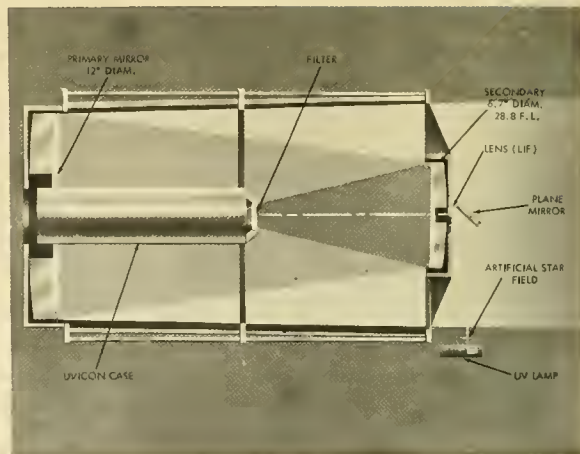

FIGURE 5-4. Schwarzschild camera as used in Celeste.

1 inch in diameter. The effective focal or transmission ratio is 3.7 assuming 75-percent reflectivity of the mirrors. The detector for this system, called a Uvicon, is shown in Figure 5-5. These are basically television tubes that are sensitive to various ultraviolet bandwidths. The photocathode material is cesium iodide or cesium telluride, and the target operates by secondary emission with a gain of about 250.

The integrating structure for the four telescope modules is shown in Figure 5-6. The experiment container houses the main support structure. The "X" frame member is attached to the spacecraft structure through four mounting lugs; it is also the member to which the Wisconsin observing equipment is mounted.

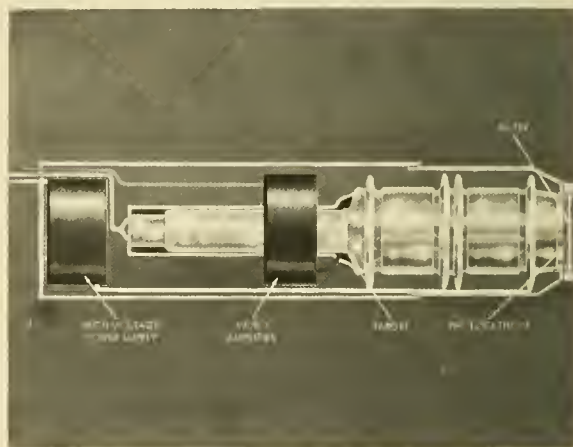

FIGURE 5-5. Uvicon television camera tube.

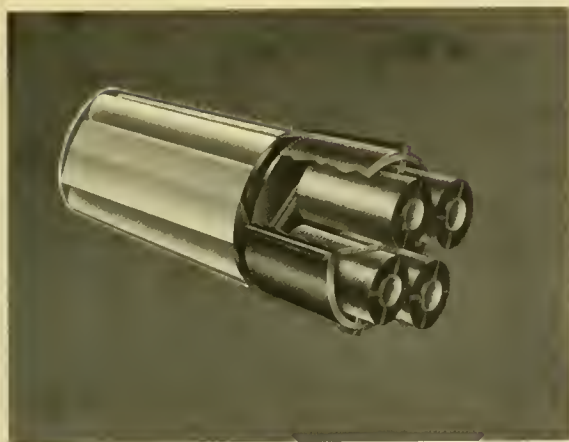

FIGURE 5-6. Integrating structure for Telescope.

University of Wisconsin Experiment

The experiment under development by the University of Wisconsin is directed toward the determination of the stellar energy distribution in the spectral region from 3000 to 800Å and toward measurement of the emission line intensities of diffuse nebulae in the same spectral region. In addition to the above objectives, it is thought that the equipment will provide the capability to follow up discoveries resulting from the Smithsonian mapping or early observation obtained with the Wisconsin equipment on rocket flights.

The equipment being developed by the University of Wisconsin consists of three basic photometric systems: (1) a multicolor filter photometer system intended primarily for the measurement of stars and consisting of four 8-inch telescopes, each telescope feeding a separate three-color filter photometer; (2) a multicolor filter photometer system intended primarily for nebulae and other extended-surface objects and consisting of one 16-inch telescope; and (3) a scanning spectrometer system employing two objective grating spectrometers of approximately 6×8-inch aperture. Schematics of this equipment are shown in Figure 5-7.

The stellar photometer system consists of four 8-inch, f/4 off-axis parabolas located in pairs on diametrically opposite sides of the experiment cylinder. Each telescope feeds a separate filter photometer. The field of view

of each photometer is determined by a selectable diaphragm stop located in the focal plane.

The nebular photometer system consists of a single 16-inch f/2 parabola. The optical axis coincides with the axis of the experiment cylinder, and the photometer is located at the prime focus. As in the stellar systems, the field of view will be determined by a selectable diaphragm.

The scanning spectrometer system consists of an objective grating of approximately 6 x 8-inch aperture and a 7 x 10-inch parabolic objective that images a monochromatic image of the star on the photometer slit located behind the grating. The spectrometer employs a 300 line/m grating in the first order, blazed for 2000Å; and a resolution of 10Å is achievable.

Goddard Space Flight Center Experiment

The equipment to be orbited in the second spacecraft is being developed by the Astrophysics Branch of GSFC and is designed to make absolute spectrophotometric measurements of stars and nebulae in the ultraviolet. The experiment will have the capability of operating in a number of different modes. For example, it can be used to obtain both steady-state and time-dependent photometric data on stars or, for that matter, any celestial object except the Sun, Venus, Mercury, and objects fainter than 11th magnitude. Because of this flexibility, it will be capable of obtaining information of use in numerous astronomical problems.

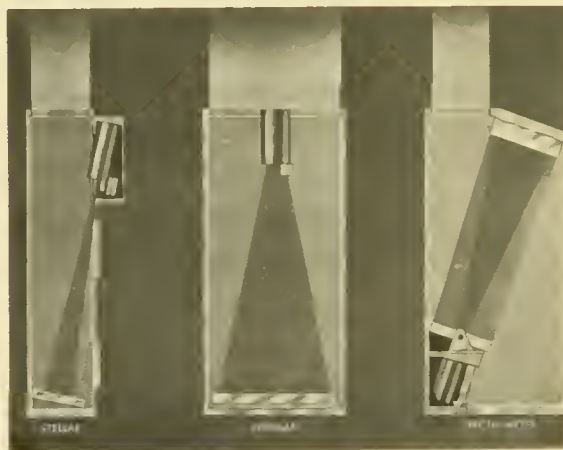

FIGURE 5-7. Wisconsin experiment optical systems.

A schematic of this equipment is shown in Figure 5-8. The 36-inch primary mirror of the Cassegrainian telescope, which collects the light from the stars, is made of beryllium because of its thermal stability. This light is focused on the entrance slit of a spectrograph that employs an 8 x 8-inch diffraction grating ruled 1200 lines/m on an aspheric surface. The exit slits for 2, 8, and 64Å spectral resolution will be provided. The resulting spectrum covers the range from 1000 to 4500Å. Six detectors, sensitive to different bands of ultraviolet radiation, are located so as to be simultaneously illuminated by different portions of the spectrum.

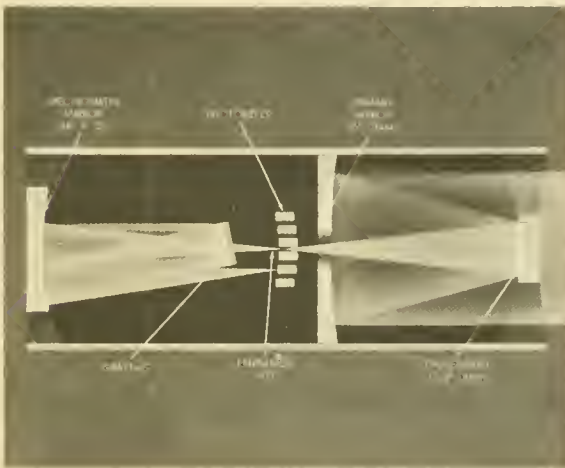

FIGURE 5-8. Goddard experiment optical system.

These detectors generate pulse at a rate proportional to the intensity of the incident radiation. The spectrometer grating may be moved in discrete increments so that the detectors are illuminated by other portions of the spectrum. The system is designed such that there is 100-percent redundancy in the data collections unless two physically adjacent detectors are lost.

The fine guidance system will provide the signals to the spacecraft control system whenever accuracies between 1 minute of arc and 1 second of arc are required.

Princeton University Experiment

The third spacecraft will carry the equipment being developed by Princeton University.

According to present cosmological theories, the stars are condensed out of clouds of interstellar gas and dust. Therefore, it is of primary interest to understand the composition and physical conditions of this interstellar matter. Since most of the interstellar atoms absorb only in the far ultraviolet, with virtually no absorption lines in the visible spectrum, the study of this interstellar gas will be measurably advanced by observations in the ultraviolet with high dispersion. The primary objective, then, is to provide quantitative observations of these ultraviolet lines.

This system consists basically of three subsystems: the telescope for collecting the radiant energy, the spectrometer for the measurements, and the error sensor for precise orientation and guidance of the observatory. A schematic of this instrument is shown in Figure 5-9.

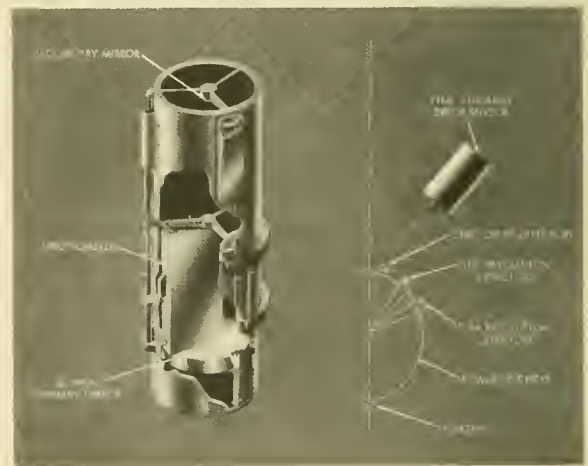

FIGURE 5-9. Princeton experiment optical system.

The optical system consists of a Cassegrainian reflecting telescope feeding the entrance slit of a concave grating spectrometer. The fused quartz primary of the f/3 telescope will be 32 inches in diameter. The secondary mirror, which has provisions for adjusting the focus, will provide an f/20 image for the spectrograph.

The entrance slit and the concave grating of the spectrograph are fixed, and the photocells behind the exit slit will scan the spectrum along the Rowland circle, which has a radius of

50 centimeters. This will provide a dispersion of 8Å/mm in the first order. A fundamental spectral resolving power of 0.1 and 0.4Å is planned.

The sensors will consist of three sets of photo-multipliers. Each set will consist of one photo-multiplier for the 800 to 1500Å band and a second for the 1600 to 3000Å band. One set of cells will be mounted at the zero-order image to monitor the amount of light passing the entrance slit; the second set will be mounted behind the 0.1Å wide slit; and the third set behind the 0.4Å slit.

A fine-error sensor is proposed that will center the selected star image on the entrance slit of the spectroscope to an accuracy of 0.1 second of arc. This will be accomplished by having a two-stage sensor, the output of which will control the fine stabilization wheels of the spacecraft. The first stage of this sensor, utilizing the light reflected from the jaws of the entrance slit when the star image falls outside the slit, should reduce a pointing error of up to 120 seconds of arc to 0.6 second of arc. The second stage of the

sensor will provide the ultimate accuracy of 0.1 second of arc.

CONCLUDING REMARKS

As is apparent from this discussion of the reasons for developing a system such as the OAO and the specific objectives of the participating members of the scientific community, the resulting effort represents a bold advance both in the possibilities of rewarding scientific information and in the engineering breakthroughs that must be accomplished before such a system is a reality. The development of the spacecraft and first three experiments is well along toward the first major goal of producing a prototype system. Although many technical problems have been solved—or solutions appear to be forthcoming, the difficulties of integration of the systems, and proof that it will operate in the required environments, is still to be accomplished. However, it appears at this time that within the next 2 to 3 years an astronomy observatory will be sending startling and new revelations back to the earthbound astronomers.

REFERENCES

1. SCHWARZCHILD, M., and SCHWARZCHILD, B., "Balloon Astronomy," *Sci. Amer.* 200 (5) : 52-59, May 1959.
2. KUPPERIAN, J. E., JR., "Astronomical Research in Space," in: *Proc. NASA-Univ. Conf. on Sci. and Tech. of Space Exploration, Chicago, November 1962*, NASA SP-11, December 1962, Vol. 1, pp. 139-145.
3. STECHER, T. P., and MILLIGAN, J. E., "Stellar Spectrophotometry from Above the Atmosphere," *Astrophys. J.* 136 (1) : 1-13, July 1962.
4. WHIPPLE, F. L., and DAVIS, R. J., "Proposed Stellar and Interstellar Survey," *Astronom. J.* 65 (5) : 285-290, June 1960.
5. SPITZER, L., JR., "Space Telescopes and Components," *Astronom. J.* 65 (5) : 242-263, June 1960.
6. CODE, A. D., "Stellar Astronomy from a Space Vehicle," *Astronom. J.* 65 (5) : 278-284, June 1960.
7. GOLDBERG, L., "Solar Experiments," *Astronom. J.* 65 (5) : 274-277, June 1960.



THE ENGINEERING DESIGN OF THE ORBITING ASTRONOMICAL OBSERVATORY

by

WALTER H. SCOTT, JR.*

Grumman Aircraft Engineering Corporation

The Orbiting Astronomical Observatory (OAO) is designed to provide an accurately stabilized, unmanned platform for astronomical observations from well above the earth's atmosphere. Of primary immediate interest is the observation of stellar radiation in the ultraviolet range, which is severely limited even in balloon experiments because of absorption in the ozone layers. The OAO is a 3600-pound spacecraft that will be placed in orbit by an Atlas Agena D. It can handle optical systems up to 48 inches in diameter, 10 feet in length, weighing 1000 pounds. The key design requirements of the spacecraft are discussed. The reasons behind the configuration are then explained, followed by a discussion of the major subsystems showing how they have been designed to meet the exacting requirements of astronomical observation.

INTRODUCTION

The basic requirements of the OAO were established by the Goddard Space Flight Center (GSFC) with the assistance of some leading astronomers.† The dimensions and weight are basically a function of the size of optics required for useful experimentation, as limited by available launch vehicle capabilities. Preliminary studies by GSFC established that a 36-inch-diameter optical system fell within the capabilities of the Atlas Agena D and would provide a useful observatory for many years to come. High pointing accuracy along with an ability to hold on a dim star for long periods of time are important requirements of stellar observation. In addition, a high-accuracy data system is required for precise spectral measurements. A carefully controlled temperature in the optical system is required to minimize distortion, and a low temperature level is dictated by most types of experiment sensors. An

orbital altitude of 500 miles was selected to be under the heavy Van Allen radiation belt but high enough to avoid an excessive number of ground installations. The above requirements result in an expensive combination of launch vehicle, spacecraft, and experiment. Therefore emphasis has been placed on designing the OAO for a long life and in maintaining a general purpose type of spacecraft that could be used for a variety of experiments with minimum redesign and retesting.

CONFIGURATION

The external design of the OAO, shown in Figures 6-1 and 6-2, consists of an octagonal body 80 inches across the flats and 120 inches high. The experiment is housed in a central tube 48 inches in diameter extending the full height of the body. Figure 6-1 shows the spacecraft as designed for two experiments, one viewing from each end. The standard configuration would be a single experiment viewing from the forward end only. The sun shade is closed over the experiment before and during launch for protection. After orientation in orbit, it is opened and protects the optical tube from sunlight. It normally would never close again unless a malfunction or a faulty program should result in the optical axis approaching the sun line, in which case the sun shade would automatically close when an angle of less than 45 degrees to the sun line is reached. An ex-

*OAO Program Manager, Grumman Aircraft Engineering Corp.

†See previous paper by Messrs. Ziemer and Kupferian.

THE OBSERVATORY GENERATION OF SATELLITES

GENERAL INFORMATION

GROSS WEIGHT - 3600 lb
 EMPTY WEIGHT - 2600 lb
 PAYLOAD - 1000 lb
 TOTAL SOLAR PADDLE AREA, 111.50 sq ft
 VIEWING FIELD:

FWD. EXPERIMENT - 270° (EXCLUDING 90° CONE TOWARD SUN)
 TOWARD SUN)
 AFT EXPERIMENT - 280° (EXCLUDING 90° CONE TOWARD & AWAY FROM SUN)

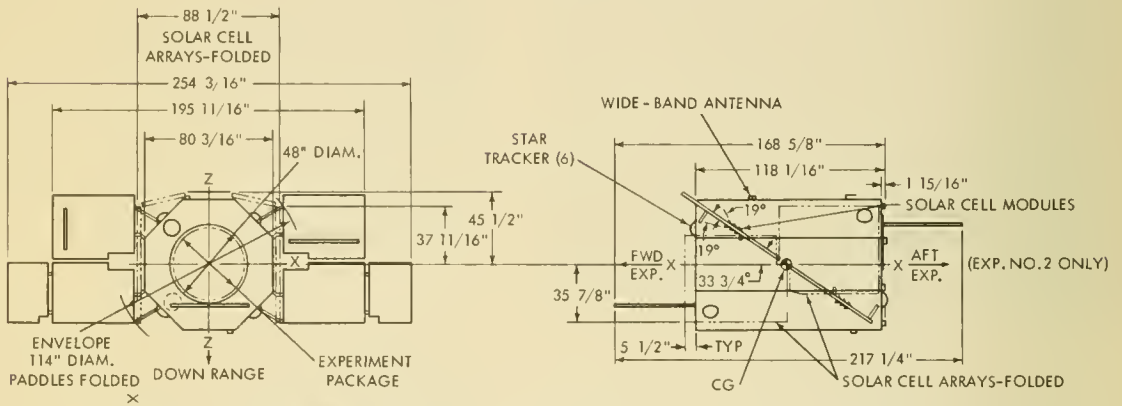
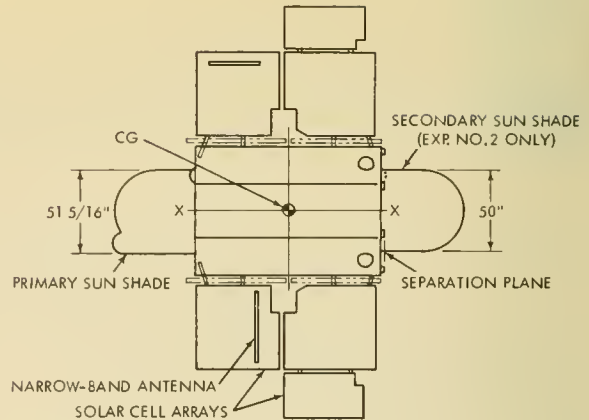
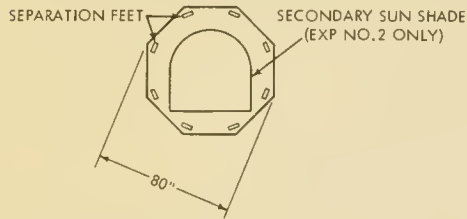

FIGURE 6-1. OAO general arrangement (double-ended experiment, spacecraft no. 1).

plosive jettison system is provided should the actuator motor fail to open the sun shade after launch.

The solar cell arrays are folded against the body during launch, the entire assembly being protected by a fiber glass fairing. Following fairing ejection, the solar arrays are unfolded to a fixed position by springs. The angle of the paddles and the saw-tooth angle of the solar cell modules were selected to provide the maximum area and the minimum angle from the normal to the sun line. Solar cells are mounted on both sides of the paddles; and, when the sun angle becomes excessive on one side, the observatory is rolled 180 degrees to expose the other side. The small penalty resulting from oblique exposure to the sun was accepted to avoid mechanical rotation of the paddles with attendant

problems of operation of bearings in a vacuum and mass shift effects on stabilization.

The internal structure arrangement of the OAO consists of a central tube surrounded by vertical trusses and horizontal shelves. All primary structure is built of riveted or spot-welded aluminum alloy. Many of the sheet-metal members are chemically milled to save weight. Bonded aluminum honeycomb is used in many areas, such as the solar paddles, sun shades, and equipment shelves, where high rigidity is required. The structural arrangement of the OAO is shown in Figure 6-3. The bays formed by the trusses and shelves provide the volume for the spacecraft equipment. The stabilization requirements for the OAO have dictated an extremely conservative design and manufacturing approach that avoids permanent set

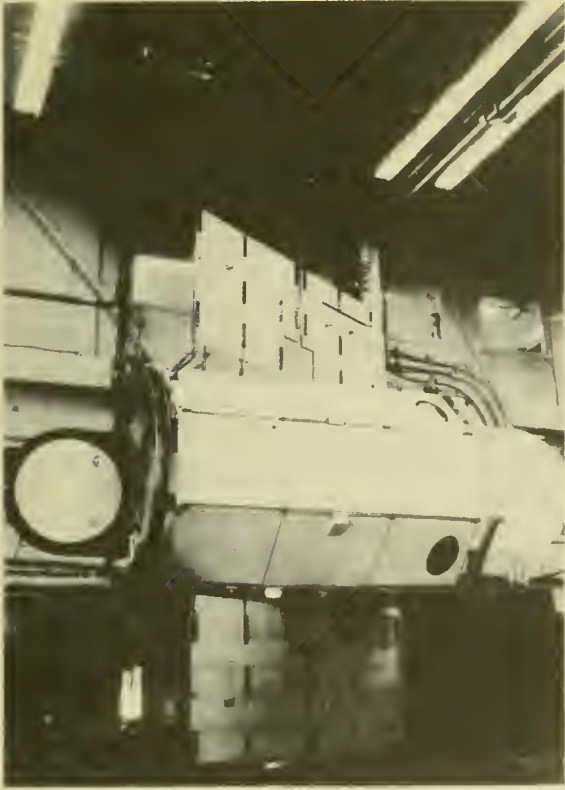

FIGURE 6-2. OAO suspended for moment of inertia measurements.

or joint slippage under launch loads. Rigid assembly fixtures are required, along with the most advanced techniques of optical tooling and alignment.

THERMAL DESIGN

The thermal design of the OAO is a passive one in that a minimum of electric heaters are used and no automatic adjustments such as variable louvers are made in the radiation surfaces of the spacecraft. The basic scheme is to isolate the spacecraft structure from external thermal effects of the sun, earth, and space and from internal heat-generating electronic equipment by means of radiation shields. The internal insulation consists of multiple layers of aluminized Mylar. External insulation is provided by the thermally isolated outer skins and by insulated or shielded exposed fittings and equipment. This approach has proved to be so successful that the best thermal configuration for the ex-

periment is achieved when the experiment is coupled conductively to the spacecraft structure. The primary temperature variations in the experiment then result from radiation in and out of the open end of the experimental tube, and can be reduced to not over $\pm 15^\circ \text{C}$ by shielding the experiment structure. Further reductions in temperature variations can be obtained by careful programming of the observatory viewing angles with respect to the sun and earth.

In addition to providing the proper environment for the experiment and minimum distortion of the structure, it is important that the electronic equipment be maintained within temperature limits for most reliable operation (0° to 160°F). The structure cannot be used as a heat sink for electronic equipment; therefore all electronic packages are designed so that heat is conducted to the outer surface of each box, which serves as a heat sink and a radiator to the outer skin. Heat flow is adjusted by means of paint patterns on the heat-sink surface. The outer skin of the OAO is a radiation shield for

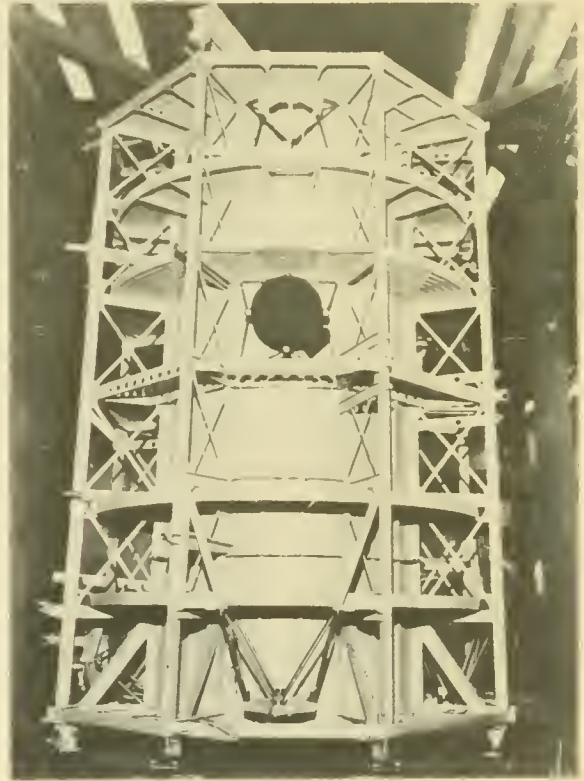

FIGURE 6-3. OAO structural arrangement.

the entire spacecraft; it is a thin aluminum surface with a finished design to both reflect solar radiation and provide a radiating surface for internal equipment.

The above system of thermal control can be maintained only through careful design of stray conduction and radiation paths. Protruding fittings such as solar paddle latches and hinges are built of fiber glass and titanium for low conductivity. All outer skins are attached to the structure by Teflon fittings. Equipment mounts are fiber glass, and internal wiring and tubing are clamped to fiber glass supports that are gold plated to avoid external radiation bounce paths.

A 5-week thermal vacuum test of a full-scale OAO with simulated equipment has proved that an experiment temperature of -30°C with a tolerance of $\pm 15^{\circ}\text{C}$ can be attained, that electronic equipment temperatures will not exceed a 0° to 160°F range, and that the structural distortions are within tolerances for the pointing requirements of the OAO. A photograph of the OAO being lowered into the chamber is shown in Figure 6-4.

STABILIZATION AND CONTROL

Following booster separation, the OAO stabilization system must first reduce the separation tumbling rates and stabilize on the sun. Following sun stabilization, a stellar reference is established. The OAO is then rotated or slewed to the desired pointing direction for the experiment. This pointing direction must then be maintained with great precision for long periods of time. Following each observation, the OAO is slewed to a new pointing direction in accordance with real-time or stored commands.

The equipment used to perform these functions can be conveniently divided into the categories of sensors and torquers. The primary sensors consist of rate gyros to measure initial tumbling rates, solar gyros to measure sun direction, and six gimballed star trackers. The latter are capable of acquiring selected guide stars and tracking them continuously, measuring their bearing with respect to the spacecraft axes. For final vernier or fine pointing, the

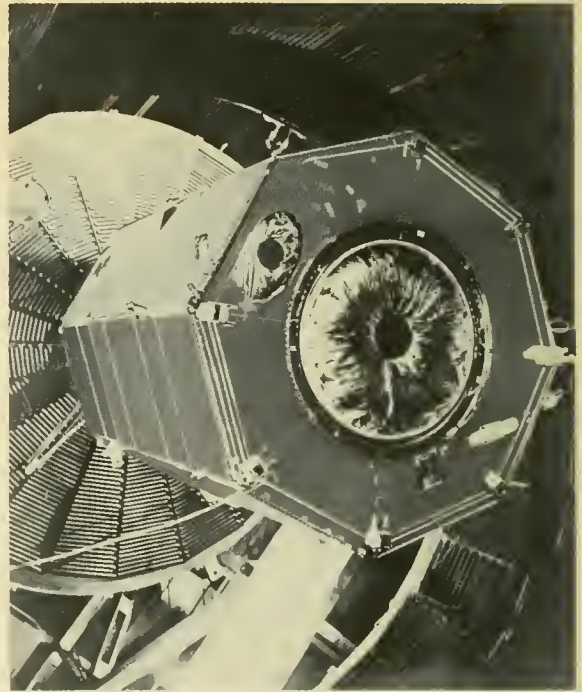

FIGURE 6-4. Lowering the OAO into the thermal vacuum chamber as viewed from inside chamber (waffle-surfaced walls are liquid nitrogen cold walls).

optics of the experiment may be used to provide fine-error signals to the control system. As a backup to the above sensors, a wide-angle TV camera with a reticle for angle measurement and a rigid star tracker, bore-sighted to the optical axis of the experiment, are provided. The torquers consist of a high-thrust nitrogen gas jet system for initial stabilization on the sun, a coarse momentum wheel system for slewing and coarse pointing using the star trackers as sensors, and a fine momentum wheel system used primarily for fine pointing using error signals from the experiment.

The OAO will encounter small external disturbance torques due to gravitational torques resulting from mass unbalance, magnetic torques due to the reaction of current loops in the spacecraft to the earth's magnetic field, aerodynamic torques resulting from the small residual atmosphere at the orbital altitude, and torques due to unbalanced solar pressure. These torques, although small—totaling less than 0.01 in.-lb, become significant if they are

sustained in one direction over a long period of time. The result is a gradual increase in momentum wheel speed until the maximum speed is reached. To unload the wheels, a low-thrust jet system is provided, operating from stored dry nitrogen. A total of 32 pounds of nitrogen at 3500 psi is stored aboard the OAO for the high- and low-thrust jets. As a backup to the jet unloading system, a novel magnetic unloading system that uses magnetometers to sense the instantaneous direction of the earth's field is provided. A computer then proportions current to a set of three orthogonal coils that interact with the earth's magnetic field to produce the desired unloading torque.

The key to the stabilization system is the gimballed star tracker, which must be able to point the OAO to an accuracy of 1 minute of arc and maintain the pointing direction within 15 arc seconds for 50 minutes of time. This accuracy is required to assure that the desired target stars will remain within the field of view of the experiment optics. Using the experiment as an error source, the fine momentum wheels are then capable of holding an accuracy of 0.1 arc second.

The star tracker consists of a small 3.5-inch-diameter reflecting telescope mounted in two degree-of-freedom mechanical gimbals. The incoming star image is split into two light beams to provide error signals about the two gimbal axes. The errors are determined by a novel system of vibrating reeds, which modulate the light received by a photomultiplier. The resulting error signals are used to drive the dc torquer motors on the gimbal axes. Gimbal angles are measured by variable capacitance transducers, which have a resolution approaching 5 arc seconds. The entire star tracker is sealed within a glass dome; and, since it is exposed, it must withstand a wide range of temperature conditions. A star tracker is shown in Figure 6-5 minus the dome. Six star trackers are provided, looking along the plus and minus directions of the three axes. The maximum gimbal motion is ± 45 degrees. Although only two trackers are sufficient to provide pointing information under ideal conditions, the increased number is provided to allow for ocul-

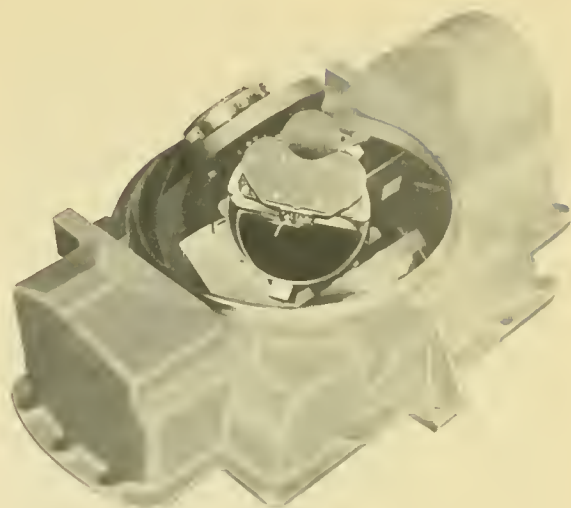

FIGURE 6-5. Gimballed star tracker with glass dome removed (view looking down telescope axis showing half-mirror). Manufactured by Kollsman Instrument Company.

tation of guide stars by the earth, maintenance of reference while shifting guide stars, and redundancy for long life.

As is the case of most complex stabilization systems, the simulation and test programs are as difficult to design and plan as the system itself. With the many variables that exist in the system, a complex analog-digital simulation* was required to prove system operation and stability. In addition, an advanced test facility,† which will be used to test the actual hardware under conditions closely simulating orbital operation, is nearing completion (Figure 6-6). The complete spacecraft electronic system is being installed on a rigid platform that is precisely balanced on a 22-inch-diameter air bearing. The air bearing consists of a hollow stainless-steel ball that has been lapped to less than 0.0001-inch error in sphericity and is supported by air pressure in a cast epoxy socket.

*Zetkov, G., and Fleisig, R., "Dynamic Analysis of OAO Spacecraft Motion by Analog-Digital Simulation," in: *IRE Internat. Convention Record, New York, March 1962*, New York: Institute of Radio Engineers, 1962, Vol 10, Pt. 5, pp. 282-296.

† Imgram, D. A., Stern, E., and Ziemer, R. R., "Design and Testing of an Ultra-High Accuracy Satellite Stabilization and Control System for the Orbiting Astronomical Observatory," in: *Proc. 13th Internat. Astronautical Congress, Varna, Bulgaria, September 1962*, Vienna: Springer-Verlag (To be published).

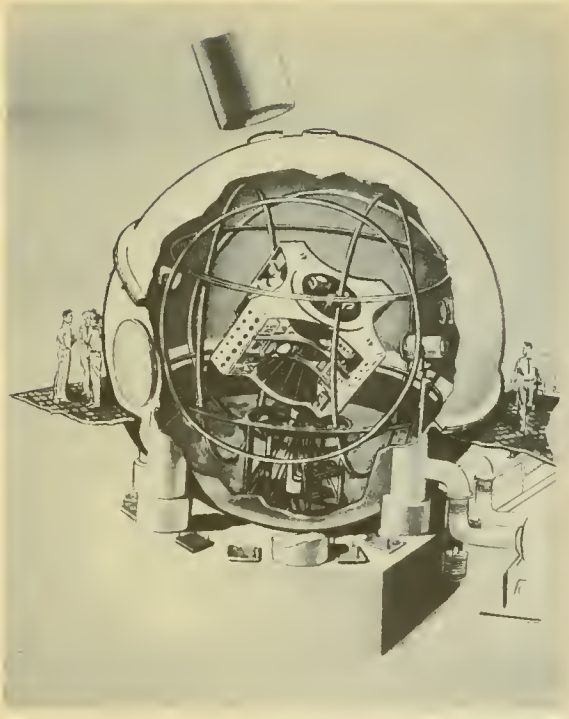

FIGURE 6-6. Drawing of space stabilization simulator (under construction; scheduled for completion January 1, 1963).

The complete simulator is installed in a 22-foot-diameter vacuum sphere to avoid thermal currents and other extraneous air forces. The vacuum sphere in turn is mounted on a 120-ton seismic foundation. Large Helmholtz coils within the sphere are used to simulate the earth's magnetic field under orbital conditions. A solar simulator and collimated star simulators complete the facility. It will be possible to operate the complete OAO system from a nearby ground station, using the actual spacecraft radio links under disturbance torque conditions closely approaching those predicted for flight.

COMMUNICATIONS AND GROUND OPERATIONS

Programs for observatory in-orbit operations will be initially prepared in approximate form by the experimenters. These programs will then be converted to digital commands by a large computer at the Goddard Space Flight Center, where the central control station will be located, Figure 6-7. The program will include

commands for general housekeeping aboard the observatory, such as equipment turn *on* and *off* and power conservation measures. The large digital computer will also predict future status data values, such as equipment temperatures, battery charge status, voltages, and currents for subsequent comparison with actual transmissions from the OAO. The prepared programs are forwarded to remote stations by microwave or teletype, where they are stored for future use. The three remote stations will be located at Rosman, North Carolina; Quito, Ecuador; and Santiago, Chile. The locations were chosen to provide at least one contact with the observatory on each orbit. The OAO has a 100-minute orbit, of which 8 to 10 minutes will be contact with a ground station. A small digital computer is installed at each remote station to store commands, process status data, and feed information to the displays. The observatory orbit and its approach to a ground station are signaled by a tracking beacon transmitting at 136 Mc. When the observatory is within line of sight, commands are transmitted in digital form at 1042 bits/sec over the command link. Two beacons and four command receivers are carried on the OAO to provide redundancy for long life. Commands are verified by echoing commands back to the ground. The complement of each command is also transmitted to the observatory where a bit-by-bit comparison is made.



FIGURE 6-7. Prototype central control station showing displays and computer. Manufactured by Westinghouse Air Arm.

Information from the OAO is transmitted to the ground by both a 1042 bits/sec digital narrow-band telemetry link transmitting at 136 Mc and an analog or digital wide-band telemetry link transmitting at 400 Mc. The narrow-band link is a PCM system used primarily for spacecraft status data that are monitored on the ground and compared with predictions to modify future programs, investigate malfunctions and, if necessary, institute an emergency "HOLD" program already stored aboard the OAO. The wide-band transmitter is the primary link for the experimenters' data. The experimenters' data storage is read out at a 50,000 bit/sec rate over this link. Experimenters' status data are transmitted at 1042 bits/sec. Analog data from the experiment or from the stellar television camera are also handled over the wide-band link and can be used for real-time operation of the experiment when within range of a ground station. Two wide-band and two narrow-band transmitters provide redundancy

for long life. Digital data can also be routed through either link in the event of complete loss of one link.

Antenna configurations have been developed and tested in an anechoic chamber to provide excellent spherical coverage. Beacon and narrow-band transmissions are handled by slot antennas in the solar arrays. The wide-band antennas consist of pitchfork configurations mounted on the sides of the body.

DATA PROCESSING

The data processing system of the OAO is designed to handle all data going to and from the observatory, including commands, experimenters' data, and status data on both the spacecraft and the experiment. It also includes two magnetic core storages: one for storing delayed commands, and the other for experimenters' data obtained while operating out of line-of-sight of a ground station. A block diagram of the system is shown in Figure 6-8.

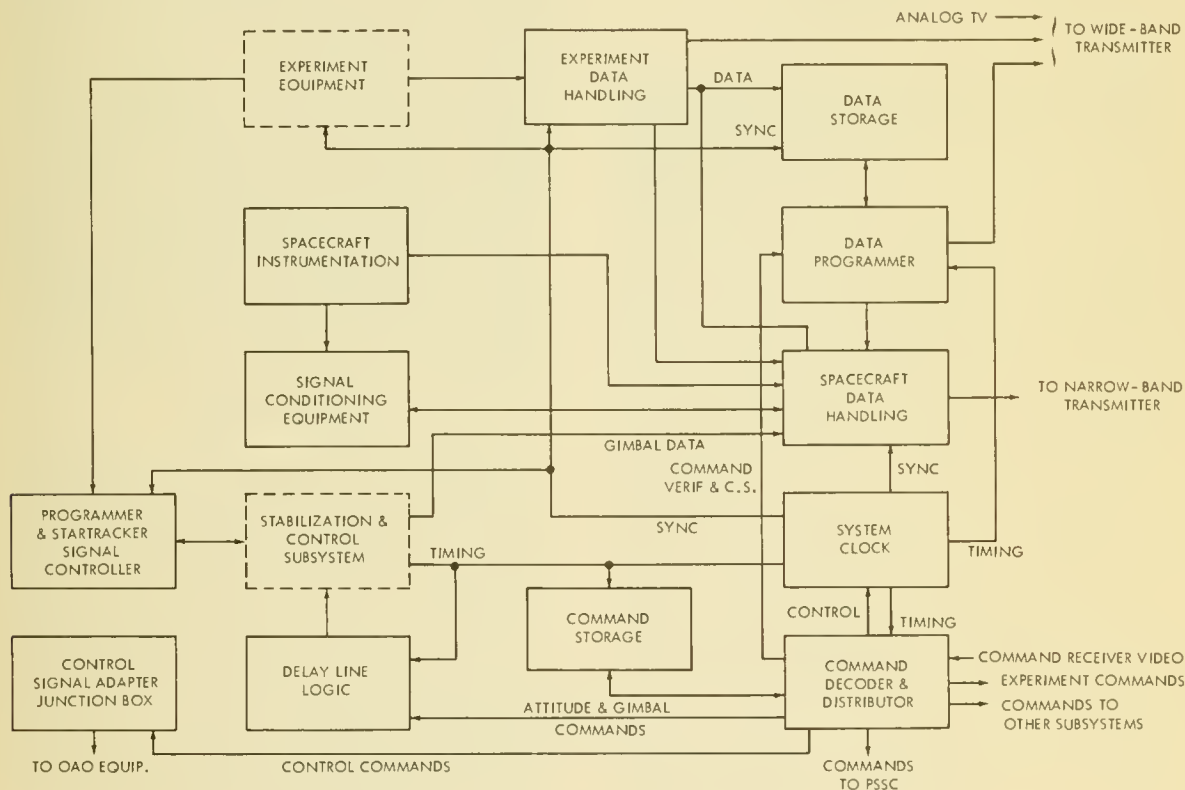

FIGURE 6-8. Data processing subsystem.

The command receiver relays commands to the decoder and distributor, which verifies, decodes, and routes commands either directly to the appropriate subsystem in the case of real-time operations or to the command storage for the delayed mode. Each command word consists of 32 bits, of which 30 bits contain command information. Seven types of commands are handled, of which a typical command would be a gimbal angle command to a star tracker. This command would be composed of the following two 32-bit words:

First Word

Bits 1 and 2	Registration
Bit 3	Real-time or Delayed Mode
Bits 4, 5, 6	Operation Code (Command Type)
Bits 7, 8	Unused
Bits 9 through 17	Execution Time
Bits 18 through 25	Address
Bit 26	Unused
Bits 27 through 31	Star Tracker Selection Code
Bit 32	Unused

Second Word

Bits 1 and 2	Registration
Bits 3 through 17	Inner Gimbal Angle
Bits 18 through 32	Outer Gimbal Angle

The command storage can store 128 command words and has quadruple redundancy for long life. Both the command storage and the separate data storage are constructed of double-aperture ferrite cores that provide nondestructive readout, permitting periodic check readouts of the command memory for verification.

The data processor also contains a system clock that provides timing and synchronization signals for observatory equipment, and delay line logic—which is used to store gimbal angles for use in the stabilization and control system.

Experimenters' data, and both the experiment and spacecraft status data, are handled by equipments that are relatively separate from the main spacecraft command system. The experiment data handling equipment can transfer data directly to the wide-band transmitter, and the spacecraft data handling equipment can operate directly through the narrow-band transmitter—the object being to provide multiple paths in case of malfunctions. These equipments contain analog gates, digital gates,

analog-digital encoders, programmers, shift registers, and a clock. The function of the equipments is to gather and prepare data in a suitable format for transmission or storage.

The data storage is arranged in two halves that can be operated in either a redundant or nonredundant mode. The total storage capability is 204,800 bits and is made up of two arrays of 64 x 64 planes, 25 planes in depth—thus providing for 8192 data words of 25 bits. Data are stored by means of 25 parallel lines from the experimenters' and spacecraft data handling equipment. Readout to the ground is handled through the data programmer, which establishes word format and maintains synchronization.

The programmer and star tracker signal controller furnishes the stabilization system with sequencing control of the star tracking stabilization modes. It can inhibit the error signal of a malfunctioning star tracker and indicates successful star acquisition. It is considered a part of the data processing system because of its digital nature, although its primary functions are more closely related to the stabilization and control system.

Design and construction techniques used in the data processing system are of particular interest. All digital equipment makes use of "quad redundant" circuitry for maximum reliability. Circuits are packaged in welded module form, encapsulated, and interconnected by printed circuit boards. Similar redundant circuit and welded module techniques are used wherever possible in other spacecraft subsystems.

POWER SUPPLY

The OAO is powered by silicon solar cells. An excess of power is generated during the sunlit part of the orbit and is stored in nickel-cadmium batteries for use during the dark part of the orbit. A battery charge and sequence controller controls the charging of the three 20 amp-hr batteries and selects the proper battery for use. A central power supply system consisting of a voltage regulator-converter and an inverter supplies all spacecraft and experiment requirements. The solar cells are p-n type, consisting of an n-type silicon wafer onto

which is diffused a p-type boron layer. Thirteen percent efficiency cells are used (tungsten light measurement) with a 6-mil cover glass providing radiation protection. A total of approximately 60,000 cells is used to generate a power of 680 watts under the most unfavorable orientation of the fixed paddles (37 degrees away from the normal). The cells are arranged to provide an unregulated voltage of 28 volts.

Nickel-cadmium batteries were specified by GSFC because of good past experience in their ability to withstand thousands of charging cycles. The cell and battery under development for the OAO have been described by Shair and Gray.* Under normal operation, only one battery powers the observatory. The other two are periodically trickle-charged. If the voltage of the operating battery drops below 23 volts, a reserve battery is switched-in by the charge controller. The upper value of voltage from the solar array is limited to 34 volts by the charge controller, which establishes the limits of the unregulated bus as 23 to 34 volts. The average depth of discharge for a battery during a typical orbit is 40 percent.

The voltage regulator and converter supplies all dc requirements of the OAO. Output voltages are +28, +18, +10, -10, and -28 volts. The inverter supplies three, two, and single phase current at 400 cycles and 26 volts.

Depending on the amount of equipment operating and their duty cycles, the total load will vary from 295 to 360 watts. The battery charge efficiency of 70 percent results in additional losses of 46 to 56 watts with a resulting total load of 341 to 416 watts. Using a conservative 60-percent-sunlight orbit and allowing for other inefficiencies in the system, the power input required from the solar cell array varies from 600 to 720 watts. For an 80-percent-sunlight orbit, the maximum power requirement is 580 watts. This compares with a solar

array output varying from 680 to 820 watts for the maximum range of sun incidence angles.

ADDITIONAL DESIGN CONSIDERATIONS

Experiments are packaged in an experiment container that provides the basic structure to align the experiment to the spacecraft structure and in addition provides a lightweight sealed dust cover that is maintained under positive pressure, with dry nitrogen on the ground to protect the optics. Mobile ground handling equipment has been designed to protect both the experiment and the spacecraft from the handling loads involved in shipping them to GSFC and, finally, to the Atlantic Missile Range.

A mobile set of checkout equipment is designed to support each flight spacecraft in the field. The equipment, which is installed in a truck trailer, is similar to the ground operational equipment in that it serves a similar function during observatory checkouts.

CONCLUSIONS

It is too early in the program to present final conclusions on the OAO; however, certain tentative conclusions can be reached on the basis of design, manufacturing, and test work completed to date:

1. The feasibility of the OAO design has been proven, and the critical initial performance requirements have been maintained through the detail design and early testing phases of the program.
2. The structure and thermal design of the OAO have been proven over the full range of environments and demonstrates that satisfactory alignment can be maintained through the launch phase and that the passive thermal design will satisfy both experiment, equipment, and structural requirements.
3. The effectiveness of long-life design by use of redundancy from the black box level down to, and including, detail circuit design can be proven only with additional experience; however, early test results offer hope of major gains from this approach.

*Shair, R. C., and Gray, W., "Hermetically Sealed Nickel-Cadmium Batteries for the Orbiting Astronomical Observatory Satellite," Paper presented at the Amer. Rocket Soc. Space Power Systems Conf., Santa Monica, Calif., September 25-28, 1962, ARS Preprint 2508-62.

ACKNOWLEDGMENTS

Many organizations have provided important assistance in the OAO design. Major contributions to the system design have been made by General Electric, IBM, Westinghouse,

Radiation, and Kollsman. The engineers of the Goddard Space Flight Center hold a close partnership in the design. Many other companies have contributed in the detailed hardware design and development.

Date Due

TL797 US ASTRO



3 5002 00173 0436

Goddard Space Flight Center.
The observatory generation of satellites

Library Bureau Cat No 1137

	TL
	797
	U5 00173 0436
AUTHOR	U.S. Goddard Space Flight Center, Greenbelt, Md.
TITLE	The observatory generation of satellites.
DATE DUE	BORROWER'S NAME

ASTRONOMY LIBRARY

TL
797
U5

