

Printed
11-J

OCEANOGRAPHIC OBSERVATIONS
ON THE "E. W. SCRIPPS" CRUISES
OF 1938

BY
H. U. SVERDRUP
AND THE STAFF OF THE SCRIPPS INSTITUTION OF OCEANOGRAPHY

DATA LIBRARY
Woods Hole Oceanographic Institution

RECORDS OF OBSERVATIONS
SCRIPPS INSTITUTION OF OCEANOGRAPHY
Volume 1, No. 1, pp. 1-64, 11 figures in text, 39 charts

UNIVERSITY OF CALIFORNIA PRESS
BERKELEY AND LOS ANGELES
1942

GC
771
58
1942

MBL/WHOI



0 0301 0041356 3

OCEANOGRAPHIC OBSERVATIONS
ON THE
"E. W. SCRIPPS" CRUISES OF 1938

	Page
...	1
.	1
	3

BY
H. U. SVERDRUP AND THE STAFF
OF THE
SCRIPPS INSTITUTION OF OCEANOGRAPHY

RECORDS OF OBSERVATIONS
SCRIPPS INSTITUTION OF OCEANOGRAPHY
EDITORS: H. U. SVERDRUP, R. H. FLEMING, L. H. MILLER, C. E. ZOBELL
Volume 1, No. 1, pp. 1-63, 11 figures in text, 39 charts
Transmitted October 27, 1939
Issued July 28, 1942
Price, 75 cents

UNIVERSITY OF CALIFORNIA PRESS
BERKELEY, CALIFORNIA

CAMBRIDGE UNIVERSITY PRESS
LONDON, ENGLAND

[Contributions from the Scripps Institution of Oceanography, New Series, No. 165]

MANUFACTURED IN THE UNITED STATES OF AMERICA

CONTENTS

	Page
Introduction	1
The Cruises of 1938, by H. U. Sverdrup	1
The "E. W. Scripps," by E. G. Moberg and J. Lyman	3
Preliminary Discussions	13
Results in Physical Oceanography, by R. H. Fleming	13
Diatoms, by W. E. Allen	25
Notes on Zoöplankton, by M. W. Johnson.	27
Tables of Oceanographic Observations, 1938	31
A. Interpolated values of temperature, salinity, and oxygen at standard depths, and computed values of σ_t , specific volume anomaly, δ , and anomaly of dynamic depth, ΔD	31
B. Interpolated values of phosphate-phosphorus content at standard depths	55
C. Plankton diatoms	57

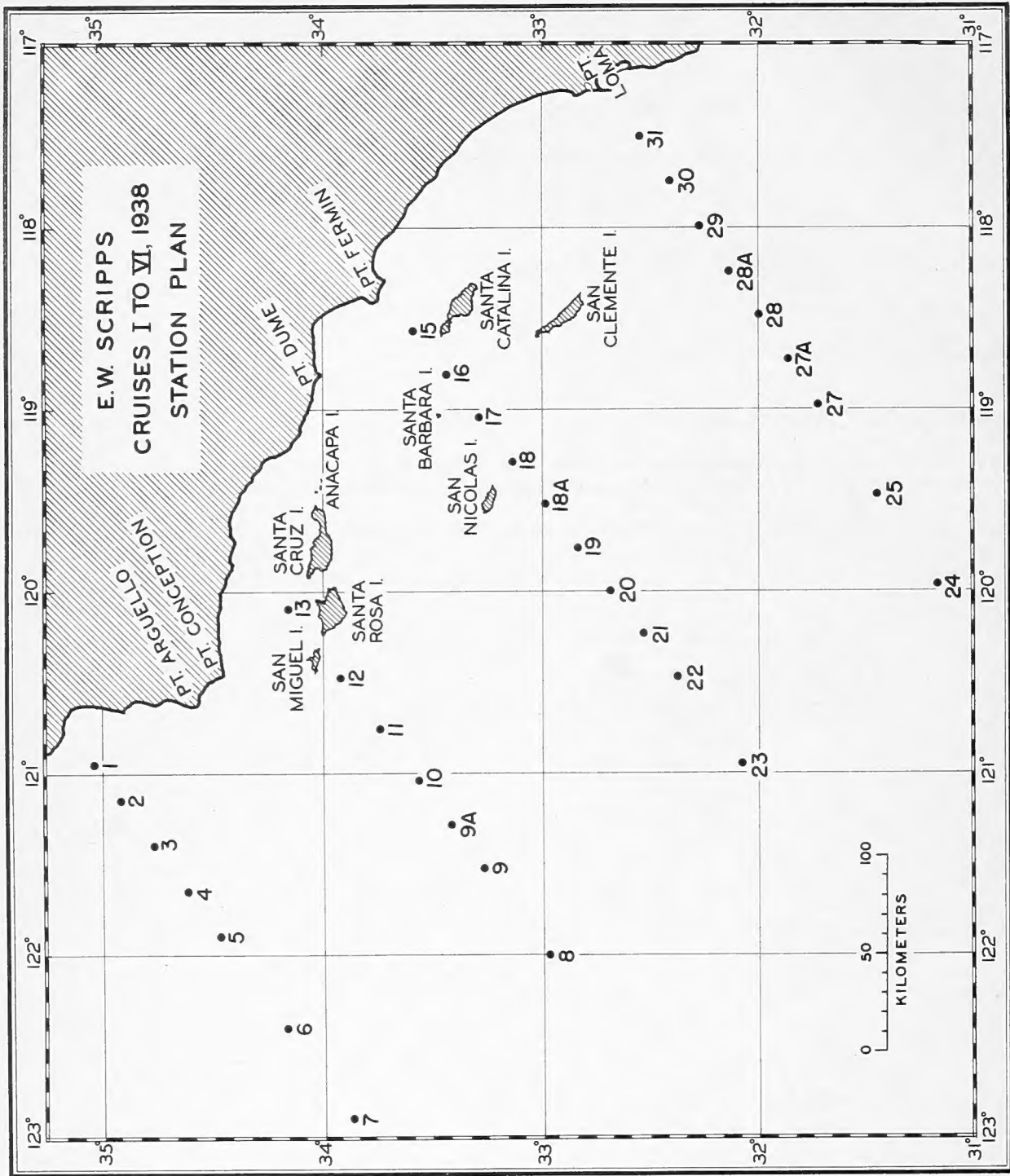

Fig. 1. Station plan of the "E. W. Scripps" cruises, 1938.

OCEANOGRAPHIC OBSERVATIONS ON THE "E. W. SCRIPPS" CRUISES OF 1938

INTRODUCTION

THE CRUISES OF 1938

By

H. U. SVERDRUP

The new vessel of the Scripps Institution of Oceanography, the "E. W. Scripps," was placed in commission at the end of December, 1937, after having been remodeled and equipped for oceanographic work. A description of the vessel is included in this report, giving its dimensions and its facilities for oceanographic work.

In 1937 a cooperation had been established with Dr. F. P. Shepard who, through a grant from the Geological Society of America, was to have the vessel at his disposal for investigation in submarine geology every second month of 1938, beginning in January. Thus the Scripps Institution would have the vessel available for its particular purposes only during every other month of the year. The most advantageous plan therefore seemed to be to continue the type of survey which had been conducted in 1937 in cooperation with the California Division of Fish and Game making use of the patrol vessel, the "Bluefin."

Figure 1 shows the area off the coast of southern California which was studied in 1937 and 1938. On the chart are indicated the locations of the stations which were to be occupied in 1938, with the station numbers. Owing to weather conditions not all the stations were occupied on certain cruises. Also, the exact locations vary slightly from those shown in this chart, but in the maps showing the results of the different cruises the actual positions are indicated by dots.

The work was planned to comprise observations of temperature, salinity, and oxygen within the layers where significant differences could be expected, determinations of phosphate phosphorus if possible, and collection of phytoplankton at seven different levels at and below the surface. Except on Cruise I vertical net hauls for zoöplankton between 200 meters and the surface were part of the routine program.

The "Bluefin" cruises¹ had shown that great contrasts in the hydrographic conditions exist off the coast of southern California and had indicated that marked changes in the character of

the currents took place during the early part of the year. The "Bluefin" cruises had also shown that significant differences in the character of the waters occurred mainly above a depth of 500 meters, for which reason the hydrographic work of the "E. W. Scripps" was limited to this depth. Observations for temperature and water samples were collected between the surface and a depth great enough to insure that the deepest samples were from a depth somewhat greater than 500 meters, except on Cruise I when most stations were worked to a depth of 1000 meters and one to a depth of 3900 meters. Water samples were obtained by Nansen reversing water bottles. Temperatures were measured by means of standard reversing thermometers, using unprotected thermometers on every third water bottle in order to determine the depth at which the bottles reversed. The salinity was determined by chloride titration, three or more titrations being made on each sample if the difference between the first two titrations exceeded 0.04 ‰ in salinity. The oxygen content was determined on board by means of the Winkler method. On the first three cruises phosphate was determined by the method of Denigès, using 1 ml. of acid-molybdate reagent to 100 ml. of sea-water sample and direct visual comparison. Results were calculated using the salt-error factor of 1.12 reported by Cooper² for these conditions.

Table 1 shows the dates of the different cruises, the number of stations occupied on each cruise, the number of temperature, salinity, oxygen, and phosphorus-content determinations, the number of samples for study of phytoplankton, and the number of vertical net hauls for zoöplankton.

On the cruises the stations were occupied in numerical order with the following exceptions: On Cruise III stations 31-15 were first occupied, then station 13, and finally stations 1-12. On Cruises IV and V station 13 was first occupied and the other stations in numerical order, and on Cruise VI the sequence was stations 13, 1-12, 23-15, and 24-31. Cruises I, II, and V could not be completed, owing to storms. Generally a somewhat rough sea was encountered to the north of

¹H. U. Sverdrup and R. H. Fleming, "The Waters off the Coast of Southern California, March to July, 1937." Bull. Scripps Inst. Oceanog. (1941), vol. 4, no. 10, pp. 261-378.

²Jour. Mar. Biol. Assoc., 23 (1938): 171-78.

TABLE 1

Summary of Observations on the "E. W. Scripps" Cruises, 1938

Cruises	Number of Stations	Number of Observations					
		Temperature	Salinity	Oxygen content	PO ₄ determinations	Phytoplankton samples	Vertical net hauls for zoöplankton
I, Feb. 15-25	30	437	440	439	440	189	0
II, April 8-12	14	172	172	170	168	85	10
III, June 7-16	33	428	430	429	423	192	25
IV, Aug. 16-25	34	441	441	440	0	238	34
V, Oct. 26 - Nov. 5	29	362	359	359	0	203	28
VI, Dec. 9-18	33	434	434	432	0	238	27
Total.	173	2274	2276	2269	1031	1145	124

Point Conception and outside a line from Point Conception passing west of San Nicolas Island. The greatest difficulties were encountered during Cruise II when, in ten days, only two lines of stations could be completed owing to bad weather and when the time available was too short to make it possible to continue the program.

Four or five of the staff members or assistants at the Scripps Institution took part in each of the cruises. These men and four of the ship's crew divided the day into six-hour watches. The stations were therefore occupied all day and night, and work went on continually during the cruise.

Dr. R. T. Young, Jr., of Worcester Polytechnic Institute, took part in Cruise IV, during which he made measurements of the transparency of the water between the surface and 60 meters at twenty stations. The results of this work have been reported in the *Journal of Marine Research*.³

Table A contains interpolated values of temperature, salinity, and oxygen content at standard depths. These values have been read off from curves showing the vertical distribution of the different properties; but prior to constructing these vertical curves, T-S curves and, usually, T-O₂ curves were constructed in order to discover possible errors. The last three columns of the table of results contain the values of σ_t as derived from McEwen's tables of 1929, anomalies of specific volume, δ , and the anomalies of the dynamic depth ΔD of the standard isobaric surfaces indicated by the argument in the first column of the table. These anomalies have been computed from Sverdrup's tables of 1934. A sepa-

rate table, Table B, contains interpolated values of the phosphate-phosphorus content at standard depths. For financial reasons it was impossible to follow the recommendation adopted by the International Association of Oceanography at its meeting in Edinburgh in 1936 that both observed and interpolated values be published. The observed values can be obtained in manuscript form from the Scripps Institution of Oceanography.

Charts have been prepared in order to show the essential results from the cruises. A very brief description of these by R. H. Fleming is included in this report, but a detailed discussion will be postponed because it has been considered essential to present the observations at the earliest possible time.

Table C shows the number of diatoms found in the different catches and the percentage of the total number which appeared to be in poor condition. The phytoplankton collections were made by means of the Allen closing bottle which has a capacity of five liters. The water sample brought up from the desired depth was filtered through a net of number-25 bolting silk. A brief summary of the more outstanding results by W. E. Allen is included elsewhere in this report.

I take great pleasure in acknowledging the enthusiastic coöperation of the crew of the "E. W. Scripps." The staff members and assistants of the Institution who took part in the cruises and in the working up of the data deserve special credit. These are Messrs. W. E. Allen, C. Davis, R. H. Fleming, C. Heusner, M. W. Johnson, E. C. La Fond, J. Lyman, E. G. Moberg, S. Rittenberg, L. Simpson, H. U. Sverdrup, R. B. Tibby.

Assistance in the preparation of these materials was given by the personnel of Works Progress Administration, Official Project No. 665-07-3-141.

³*Jour. Mar. Research*, vol. 2, no. 2, 1939.

THE "E. W. SCRIPPS"

By

E. G. MOBERG AND J. LYMAN

A wooden auxiliary-motor vessel of the Gloucester-schooner type, the "E. W. Scripps" was built at Sausalito, California, in 1924 by J. H. Madden and Son from designs by Lee, Brinton, and Wayland, Inc., of San Francisco. She was intended as a yacht for ocean racing and extended cruising and originally carried a gaff-headed two-masted schooner rig with fidded topmasts. "Aurora" was her original name, which was changed to "Serena" under a later ownership. As the "Serena" the vessel was purchased at Los Angeles in April, 1937, by the late Robert P. Scripps for donation to the Scripps Institution of Oceanography to replace the motor vessel "Scripps" destroyed by explosion and fire at San Diego in November, 1936. The work of converting the "Serena" for scientific purposes was undertaken by the San Diego Marine Construction Company. On December 1, 1937, permission was received from the Director of the Bureau of Marine Inspection and Navigation to change her name to "E. W. Scripps," in honor of Edward Wyllis Scripps, father of Robert P. Scripps and one of the founders of the Scripps Institution of Oceanography. The vessel was formally transferred to the Regents of the University of California later in December and was ready for use in January, 1938.

Construction and design. - The registered particulars of the "E. W. Scripps" are as follows:

Tonnage, gross	108
Tonnage, net	59
Length, feet	93.7
Beam, feet	21.1
Depth, feet	11.9
Official number	224055
Signal letters	KLNT

On a draft of 12 ft. 3 in. her waterline length is 86 ft. 2 in. and corresponding displacement tonnage 135. The overall deck length is 104 ft.

Figure 2 gives the hull lines of the vessel to the outside of the planking. They show the hollow bilges, cut-away forefoot and raking keel of the Gloucester-fisherman model, which is characteristic of most large American schooner yachts.

The following table gives details of her scantlings:

<u>Position</u>	<u>Dimensions</u>	<u>Timber</u>
Keel and forefoot. . .	18" x 20"	Oregon pine
Stem	12" sided	Apitong
Propeller and rudder posts . . .	12" x 14"	Apitong
Frames	3-3/4" sided	Apitong
Clamp	3-3/4" x 9-3/4"	Oregon pine

<u>Position</u>	<u>Dimensions</u>	<u>Timber</u>
Shelf	3-3/4" x 22"	Oregon pine
Ceiling	2-1/2"	Oregon pine
Ceiling, 6 bilge strakes	3-3/4" x 7-3/4"	Oregon pine
Deck beams	3-3/4" x 6"	Oregon pine
Beams at deck openings	5-3/4" x 6"	Oregon pine
Deck	2-3/4" x 2-3/4"	Oregon pine
Covering board . . .	3-3/4" x 10"	Teak
Bulwarks	12" high	Teak
Outside planking . .	2-3/4"	Port Orford cedar

The frames are double, spaced 16 in., and mold from 8 in. at the heels to 4 in. at the heads. Every fourth frame is double-sawed; the rest are steam bent in one piece. Floors of sawed frames are of apitong, 6 in. x 8 in. Floors of bent frames are wrought iron, 1/4 in. x 4 in. at ends to 1-1/2 in. x 4 in. on keel, and running up 18 in. on the frames. They were galvanized after fitting. The stern transom is framed with Port Orford cedar and sheathed with teak. The ceiling is fastened with two 1/2-in. screw bolts in each frame and edge-bolted between frames. The outside planking ranges from 14-in. width at the garboards to 6-in. in the topsides and is fastened with 3/8-in. x 5-in. spikes. All fastenings are galvanized iron.

The vessel has 30 tons of cast-iron ballast consisting of two sections bolted to the underside of the keel with twelve 1-3/8-in. bolts passing through the metal floors and set up with nuts.

Eight hanging knees, 3 ft. 6-in.- x 4-in.- sided, are worked in each side, and lodging knees 2 ft. 8 in. x 4 in. at all deck openings. The joiner work is teak above deck and teak, mahogany, and pine plywood below.

Rigging. - Figure 3 on page 5, gives the sail plan of the vessel. The headsails are the original rig, the mainsail has been made smaller by eliminating the gaff and shortening and raising the boom, and the foresail has been reduced in hoist. The topmasts and all their gear have been removed. The trysail shown in the plan is generally set when hove to for work at a station in any kind of breeze, since it aids in keeping the vessel broadside to and also contributes to an easier motion.

Mainsail and foresail use wooden mast hoops, rather than the more modern travelers and track. The standing rigging is 7/8-in. wire rope, set up to chain plates with rigging screws. The spars are all solid sticks of Oregon pine, the mainmast

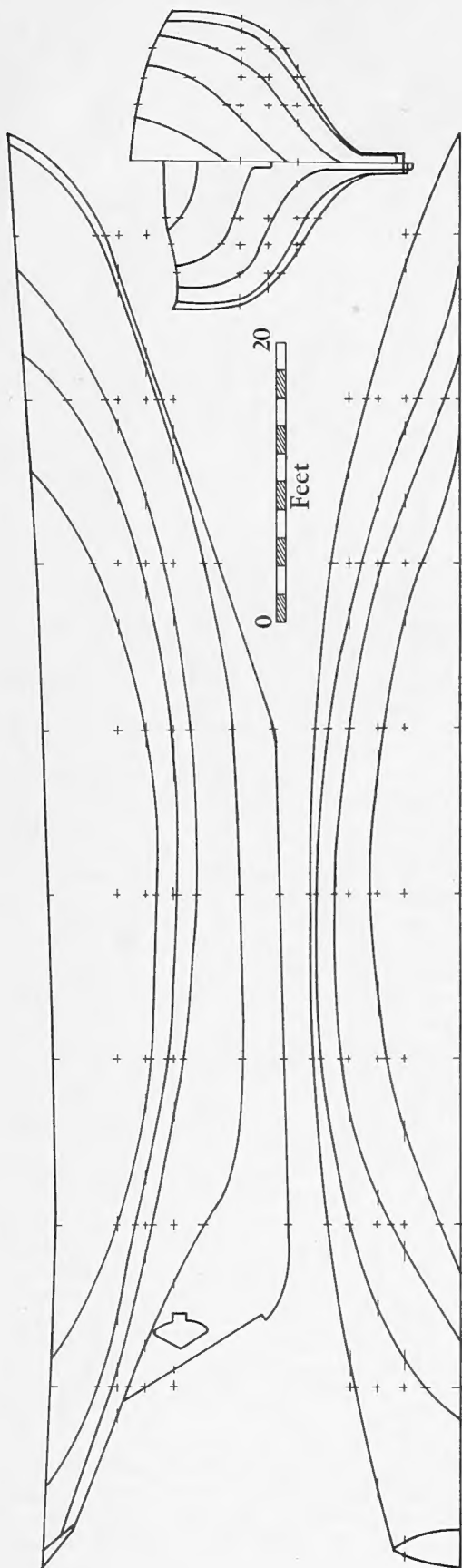

Fig. 2, A, B. Hull lines of the "E. W. Scripps."

being 74 ft. long from deck to truck and 15-1/4 in. in diameter at the deck, and the foremast 66 ft. and 14-3/4 in., respectively. In addition to the mainsail boom two working booms are fitted on the mainmast: an 18-ft. boom to starboard for the hydrographic winch and a 20-ft. boom to port for the trawling winch.

Deck fittings. - The deck layout of the vessel is shown in figure 4. She is entirely flush-decked fore and aft. There is a 12-in. bulwark all the way around, while a 3-ft. rail with removable sections in the wake of the working booms is fitted abaft the main rigging and across the stern. The anchors, consisting of a 521-lb. Baldt navy-type stockless anchor, a 400-lb. old-style anchor with shipping stock, and a 600-lb. sand anchor, are carried on deck forward. There is a total of 140 fathoms of 3/4-in. galvanized chain, which stows in the chain locker. The anchor windlass has electric drive and an anchor davit is provided for getting the ground tackle on deck. Between the windlass and the foremast are a hatch and a skylight to the forecabin. The foremast has a pinrail, and at port and starboard are skylights to the galley. Abaft the foremast is the dredging winch, and then a long skylight divided into three sections. In the forward third the batteries are stowed; the second ventilates the engine-room, and the after third the saloon.

The lifeboat, a standard metal boat, 18 x 6.5 x 2.8 feet, weighing 1300 lbs., is carried to starboard of the skylight; and to port, the work boat, a 14-ft. wooden skiff with an outboard motor. Abaft the skylight are the mainmast and pinrail. On each side of and slightly abaft the mainmast there is an electrically driven gypsy-head to which all the halyards can be led. The deck pump is directly abaft the mainmast; then follows the main companion trunk on which are mounted the pelorus and radio direction-finder.

On deck to starboard of this trunk is the hydrographic winch. The section of rail opposite the winch is removable and a sounding platform, a teakwood grating measuring 20 in. x 60 in., is hinged to the gunwale in such a way that it can be stowed flat against the main rail when not in use. Another removable section of rail fits into sockets on the outboard side of the platform while lanyards between it and the main rail enclose the fore and after sides.

Abaft the companion is the deckhouse, of which the forward part is the pilothouse and the after-part the deck laboratory with an open hatchway leading to the laboratories below. Abaft the deckhouse is the manhole to the lazarette, the standard compass, spare wheel, and steering-gear box.

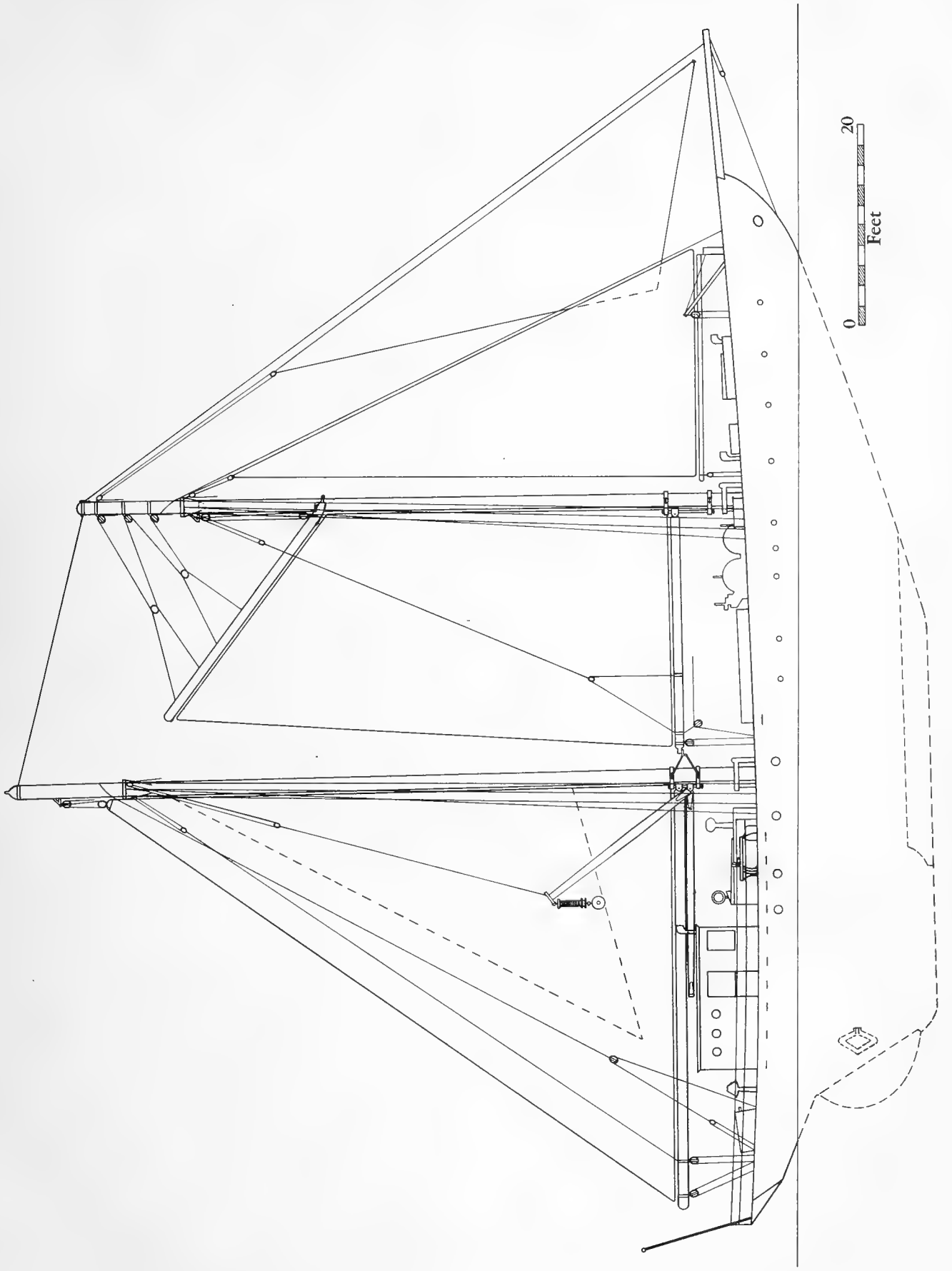

Fig. 3. Sail plan of the "E. W. Scripps."

Accommodations. - Figure 5 gives the below-deck layout of the "E. W. Scripps." In the forepeak is the chain locker, with a passage to the forecabin. There are two built-in and five pipe berths in the forecabin. The crew's lavatory, the captain's room with single berth, and a locker containing carbon-dioxide tanks for the fire-extinguishing system open into the forecabin. Aft, the galley runs across the entire width of the vessel. On the fore side of the galley to port stands a Ray diesel oil-burning range and a water heater and, to starboard, a 10-cu.-ft. electric refrigerator. On the starboard side there are a sink with running hot-and-cold fresh water and a hand pump supplying sea water. Tables, shelves, and cupboards occupy the port and after sides. From the galley a passage leads to the saloon. On the starboard side of this passage are two berths, and on the port side is the engine room.

In the saloon is a mess table measuring 3 ft. 4 in. x 6 ft. 6 in. with a settee on the starboard and after sides and folding chairs for the other two sides. Opening off the saloon is a stateroom with two berths, and a passage leading aft. On the port side of this passage are situated a lavatory, a single-berth stateroom, and finally a stateroom with three berths; on the starboard side are the door to the laboratories and the companionway to the deck.

Tanks. - A bulkhead separates the after stateroom and laboratory from the lazarette in which are two 650-gallon fuel-oil tanks. The rest of the fuel tanks are in the engine room, making a total capacity of 2000 gallons of fuel oil. Lubricating oil is carried in a 50-gallon tank in the engine room and in an 80-gallon tank built under a sideboard in the saloon.

A total of 635 gallons of fresh water is carried in five tanks under the saloon, four to starboard and one to port. Distilled water is carried in a 55-gallon tin-lined copper tank in the after laboratory. Two septic tanks are located abaft the fresh-water tanks, port and starboard. These take the drains from the lavatories and sinks, discharging to the outside through the bilge pump.

Machinery. - When built, the vessel was equipped with an 80-HP diesel engine, but this was replaced in 1929 by the present engine, a six-cylinder, four-cycle, direct reversing Winton diesel, rated at 175 HP at 450 revolutions, giving a normal cruising speed of eight or nine knots under power. Originally this engine had an air-injection system, which in 1937 was replaced with a Bosch solid-injection system. Circulating water for the engine is supplied by a 1-HP Fairbanks-Morse electrically driven 1-in. centrifugal pump, mounted on the forward end of the main engine, with intake direct from the sea. An air compressor, a 3-HP electric Winton unit, stands on the forward port side of the engine room. Arranged in a tier on the starboard bulkhead of the

engine room are eight compressed-air tanks, five of which will carry air at a pressure of 650 lbs. and three at 1000 lbs. for starting the main engine. The engine exhaust leads under the counter and discharges below the waterline at the stern.

A 3-in. centrifugal pump powered by a 3-HP Westinghouse motor placed under the starboard side of the galley serves for fire, bilges and drainage. Fresh-water pressure is maintained by another 1-1/2-HP electric pump also under the starboard floor of the galley. Fire protection is provided by a "CO-Two" system, with both manual and thermostat controls for engine room and bilges. There are also a number of portable fire extinguishers of various types in strategic positions.

Electrical equipment. - Electric current is supplied by an engine-generator unit mounted on Korfund shock-absorbing springs to port of the main engine. The engine is a model GA-2, two-cylinder, four-cycle Superior diesel engine direct-connected to a Westinghouse generator and booster generator. This engine is rated at 21 HP at 1200 r.p.m. The main generator is a single-bearing type, with compound-series field winding, and is rated at 115 volts and 15 kilowatts at 1200 r.p.m. A special-series field winding is provided for cranking the engine from the battery. The function of the booster generator is to provide the extra voltage needed for charging the batteries as a unit without raising the line potential above the usual 115 volts. The booster generator has a differential-series winding limiting the battery-charging current to 40 amperes at 10-volt boost and giving a maximum boost of 25 volts at no charging current. This differential winding carries the booster-armature current only; the main field has a constant potential 115-volt winding. This method of battery charging also tends to maintain a constant line voltage, since the batteries assist through the booster generator in smoothing out voltage changes caused by sudden load changes. The batteries are Exide Ironclad, type MVA 9-plate lead cells; fourteen 8-volt units in series with a capacity of 137 ampere-hours.

The speed of the winch motors is regulated by controlling the voltage of the main generator through variation of its field voltage. In this manner a maximum of from 175 to 185 volts may be produced. While this control is being used, the rest of the ship's load is taken directly from the batteries; consequently the main electrical system always has a constant potential of about 115 volts, for which most of the equipment is designed. When the extra voltage connection for maximum hoisting speed is not required, the generator will connect to the line automatically whenever its voltage is normal and will disconnect when the voltage is reduced. Figure 6 is a diagram of the electrical connections. The Westinghouse switchboard is hinged for rear accessibility and has heavy-duty contactors and relays for all automatic hoist-motor connecting functions. Feeder and transfer switches are standard navy-type knife switches.

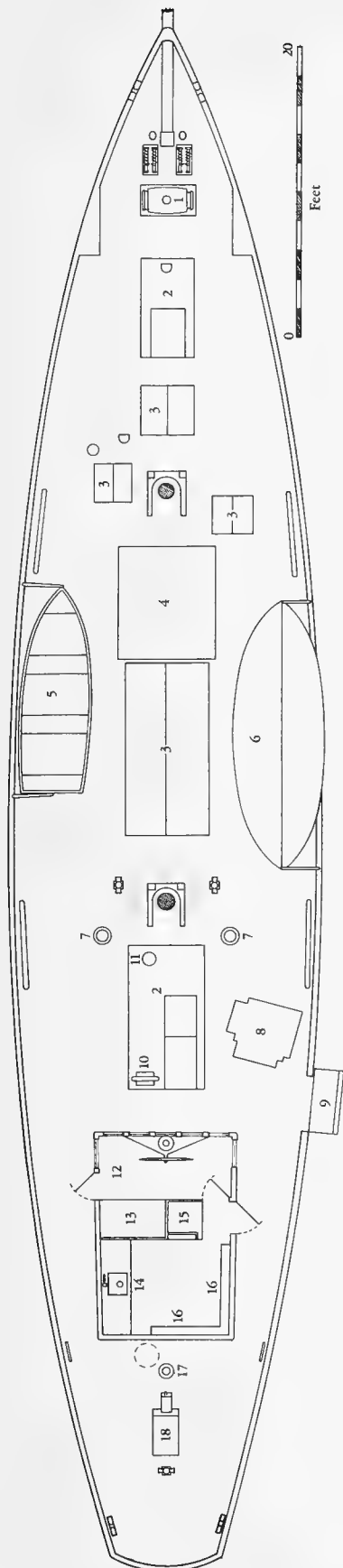

Fig. 4. Deck plan of the "E. W. Scripps": (1) anchor windless; (2) companionway trunk; (3) skylight; (4) dredging winch; (5) workboat; (6) lifeboat; (7) sail hoist; (8) hydrographic winch; (9) working platform; (10) radio direction-finder; (11) pelorus; (12) pilothouse; (13) chart table; (14) deck laboratory; (15) hatch to below-deck laboratories; (16) Nansen bottle rack; (17) standard compass; (18) steering-gear box.

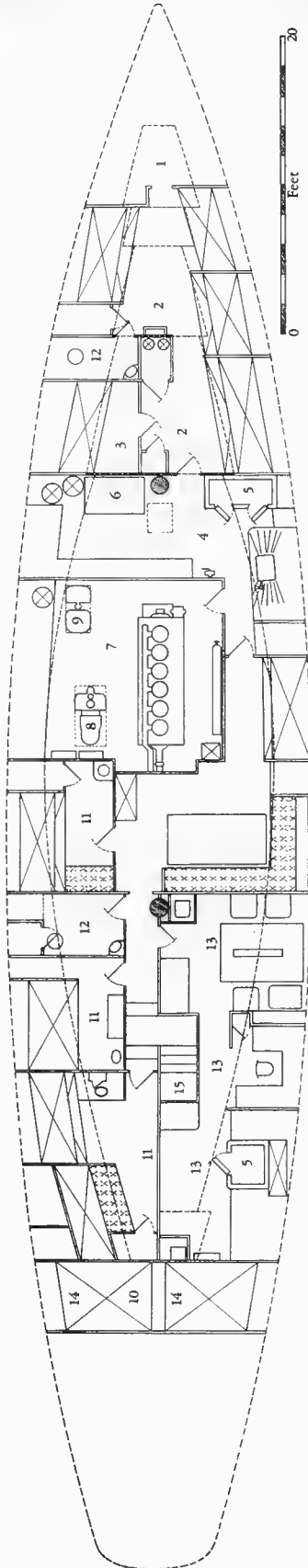

Fig. 5. Accommodation plan of the "E. W. Scripps": (1) chain locker; (2) forecabin; (3) forecabin; (4) galley; (5) electric refrigerator; (6) galley range; (7) engine room; (8) auxiliary and generator; (9) air compressor; (10) saloon; (11) stateroom; (12) lavatory; (13) laboratories; (14) fuel-oil tanks; (15) companionway to deck.

Navigation equipment. - Most of the navigation equipment is in the pilothouse. In the after port corner is a 3- x 4-1/2-ft. chart table with drawers underneath in which most charts can be stowed without folding. The standard compass is an 8-in. liquid compass by Ritchie of Boston, mounted in a standard binnacle aft of the deckhouse. A 7-in. Ritchie compass mounted in the pilothouse serves as steering compass. A hand telegraph connects pilothouse and engine room. Also in the pilothouse is the recording log, connected to a small propeller mounted on the starboard side of the hull near the stern, which indicates on separate dials speed and distance run.

There is an electric siren mounted on the main masthead. A standard U.S. navy-type pelorus with illuminated dial is mounted on the portside of the companionway trunk. Also mounted on this trunk is a radio direction-finder, a Bludworth "Mariner" model with fixed loop. A sonic depth finder, Submarine Signal Company "Fathometer" model 710, is situated over the chart table in the pilothouse. In this model the shoal-water or visual-signal method is designed for depths to 250 fathoms, and the acoustic method for depths to 1000 fathoms. In actual practice either method can be used for taking soundings successfully in depths two or three times as great, depending upon the nature of the sea bottom and the condition of the sea.

An ordinary short-wave radio receiving set in the pilothouse, together with a single chronometer, provides adequate timekeeping. A 100-watt Sound Products radio-telephone installation in the saloon provides communication with other vessels so equipped, as well as with shore stations.

Hydrographic winch. - The hydrographic winch (fig. 7) was built in 1934 by Allan Cunningham of Seattle for the "Scripps," and, salvaged from the wreck in 1936, was rebuilt in 1937 for the "E. W. Scripps." It originally had two drums--one for hydrographic work and one for dredging--but since a separate and more powerful winch was obtained for the heavier work, the dredging section of the old winch was removed. The drum is of the double-cone friction type, the friction being applied by means of a double-helix mechanism operated by a hand lever. Braking is provided by an asbestos-lined brake band, also operated by a hand lever. The drum carries 20,000 feet of 5/32-in., 7 x 7-construction, galvanized plow-steel wire rope. The rope is laid evenly in close layers on the drum by means of an automatic spooling mechanism consisting of a carriage fitted with two vertical rollers which guide the wire. The rope is moved the length of this drum along guides by means of a diamond screw driven by gearing-and-sprocket chain from the drum. To the carriage of the spooling mechanism is attached a wire-metering device consisting of a sheave and a recorder with four dials indicating 10 to 10,000 meters, respectively.

The winch is driven by a reversing compound-

wound Westinghouse motor (Type 33 SK), rated at 5 HP and 1150 r.p.m. at 115 volts; however, with the excess voltage obtainable from the generator and by using outside cooling the actual maximum continuous output is at least 7-1/2 HP and 1450 r.p.m. The motor is cooled by forced ventilation from an electric blower attached to the motor housing. The speed of the winch is regulated by a special portable rheostat which controls the generator-field voltage. This rheostat has over 60 control steps, special waterproof protection, and 15 feet of heavy-duty extension cord. When the winch is used, the rheostat is attached to the blower housing, where it is readily accessible to the operator. This motor can exert full torque continuously at any speed from 0 to 150 per cent of rated speed, and the rheostat gives very fine speed control at any load and speed. A starting and reversing switch is mounted on the side of the companionway trunk directly behind the operator.

From the drum the wire rope leads between the rollers of the spooling mechanism, under the metering sheave, which is mounted immediately back of the rollers, then through a sheave at the outer end of the starboard work boom and into the water at a convenient distance from the working platform. Between the boom and the sheave is an accumulator consisting of a double-compression spring which will sustain an outboard load of about 1500 lbs. before becoming totally compressed. The wire rope has a tensile strength of about 2600 lbs.

Dredging winch. - This winch (fig. 8) was built by the Stephens Adamson Company of Los Angeles. The drum carries 20,000 feet of 3/8-in. plow-steel wire rope constructed of six 19-wire strands and a wire-rope center. The breaking strength of this rope is approximately 26,000 lbs. The winch is powered with a totally enclosed Westinghouse (Type 103 SK) 115-volt electric motor. This non-reversing, compound-wound motor is rated at 15 HP at a speed of 1150 r.p.m. The motor is connected to a Ford-truck transmission having a clutch and gearshift with four forward speeds ranging from 6.4:1 to 1:1 and one reverse speed. The speed is further geared down through a 7:1 reducing-gear box and is then transmitted by chain drive to the drum with another reduction of 45:16. The drum is equipped with a friction brake and a ratchet gear with pawl. Brake and pawl are operated with hand levers, and the clutch with a foot lever. In addition to the gearshift the portable rheostat described under "Hydrographic winch" controls the motor speed. For starting and stopping the motor a push-button switch is installed in a convenient position. The wire rope is spooled and metered by a device similar to that on the hydrographic winch. From the spooling-metering device the wire rope leads through a snatchblock on the mainmast and then through a sheave slung by a heavy-duty compression spring from the end of the port working boom. On hauling in at normal motor speed the wire speed can be varied by shifting gears

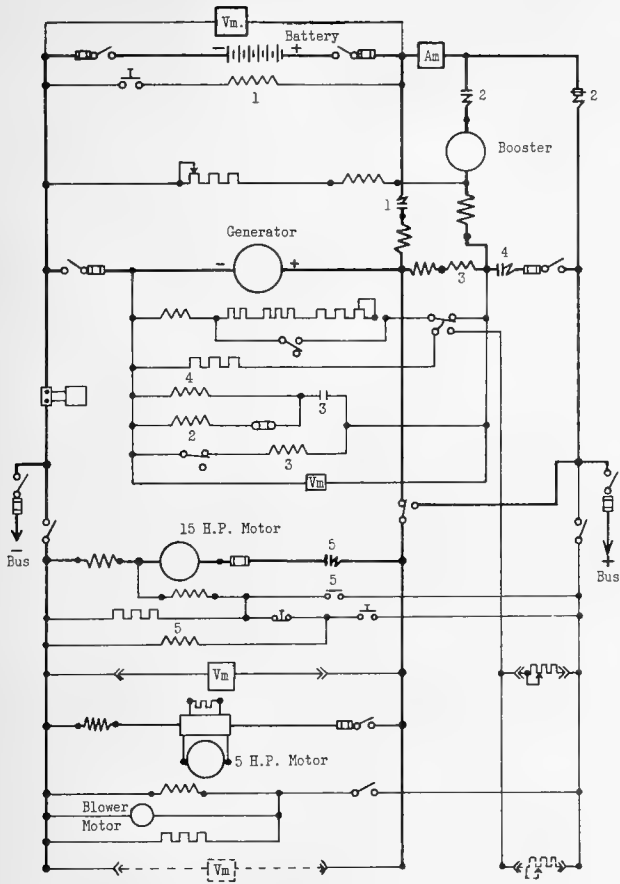

Fig. 6. Electric wiring diagram of the generator, battery, and winch motor circuits. The light system and the other motors are taken off the bus circuit, which is maintained at a constant potential of 115 volts, as described in the text. Coils represented by right angles are resistances; those by acute angles are magnets. The numbers connect the respective parts of relays.

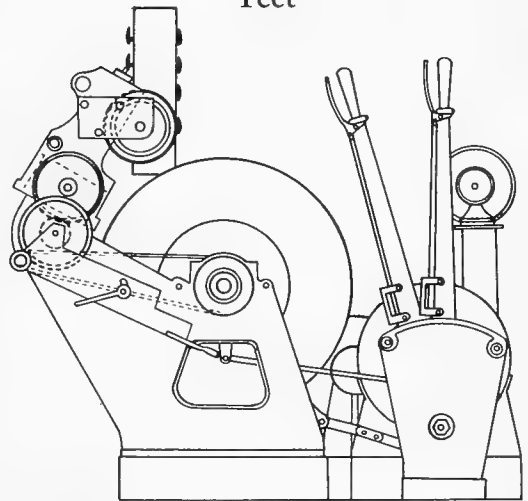
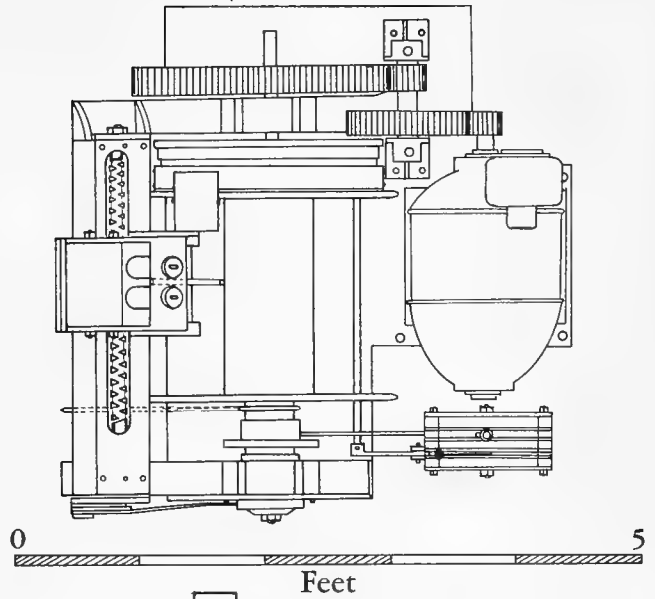

Fig. 7. Hydrographic winch.

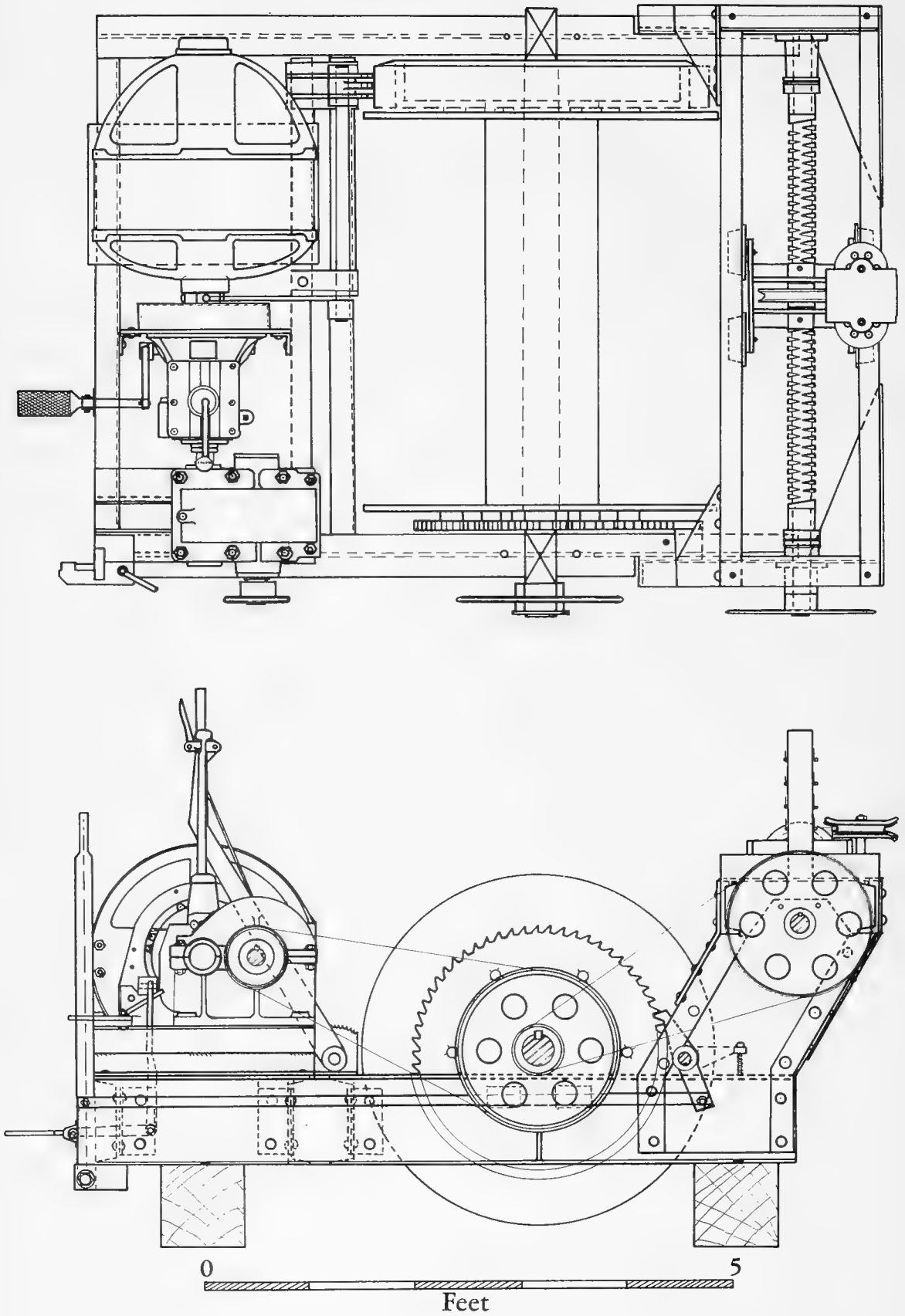

Fig. 8. Dredging winch.

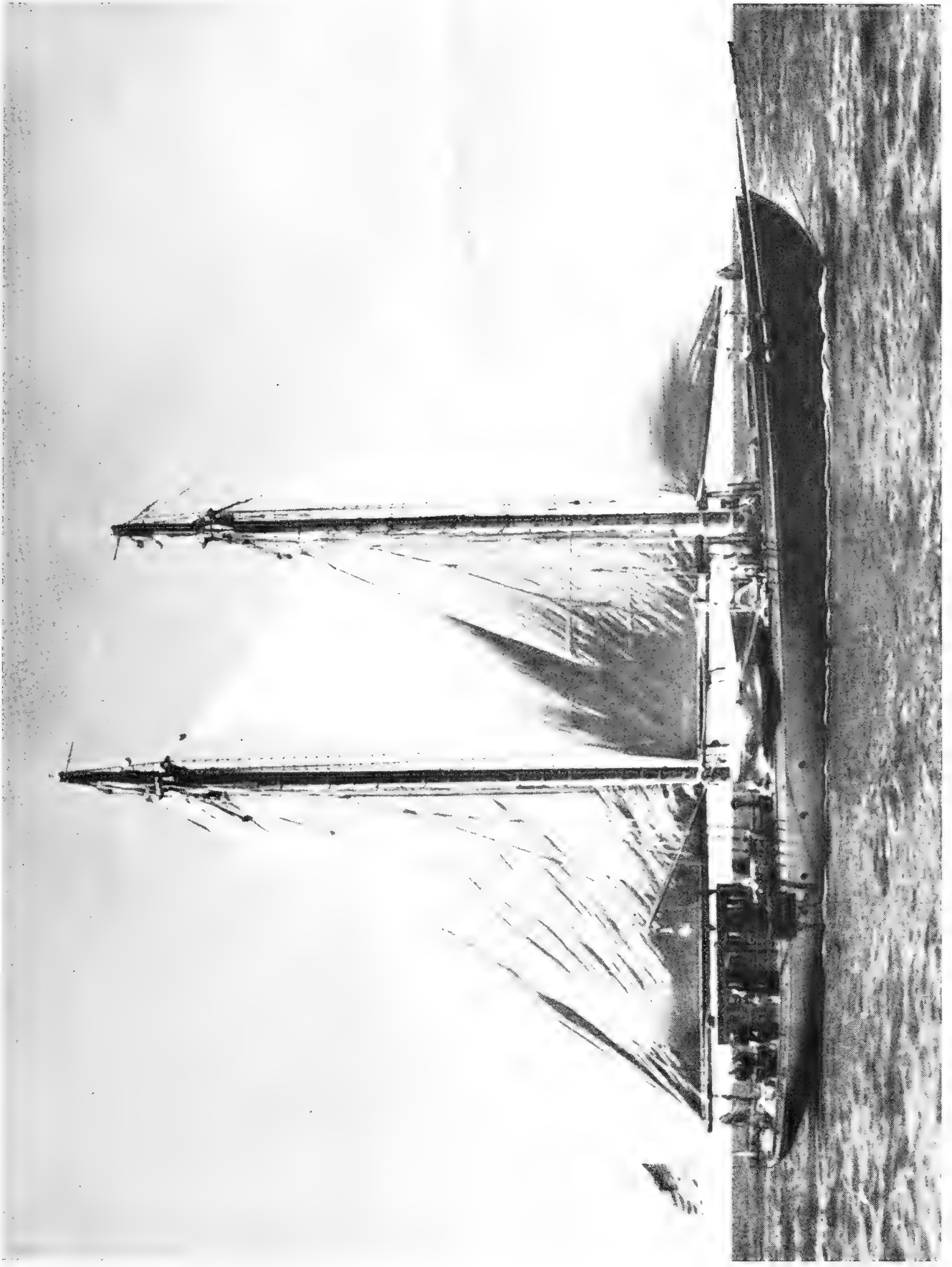

Fig. 9. "E. W. Scripps" off La Jolla, May, 1939.

from an average of about 40 feet per minute to about 300 feet per minute with a load of about 7,000 lbs.; in any gear the motor can be varied by the rheostat from almost nothing up to 150 per cent of rated speed.

Laboratories. - As shown in figures 4 and 5, there is a laboratory in the afterpart of the deckhouse and three others below deck. Athwart ship the deck laboratory measures approximately 9 feet, its port half being 7 feet long and its starboard half 10 feet. Forward on the starboard side a door leads to the deck, a second door to the pilothouse, and a hatch to the laboratories below. On the starboard-deck laboratory wall, aft of the door to the deck, and on most of the after wall there are racks for about twenty Nansen reversing water-collecting bottles. Under the Nansen bottle racks are racks for various types of bottles for water samples. Along the entire portside there is a laboratory bench with an acidproof sink and a salt-water hand pump. Under the bench are drawers and lockers.

The below-deck laboratories (fig. 5) occupy all the space to starboard of the center line and between the saloon and lazarette bulkheads. These laboratories are arranged in three sections. The after section, which connects directly with the deck laboratory, has shelves for storing water samples, an electric refrigerator, and a small laboratory bench. The center section at table height measures only about 6 ft. x 6 ft., but it has convenient working benches on three sides and can be darkened whenever necessary for colorimetric and similar work requiring reduced light. The forward laboratory section, measuring 8 ft. x 10 ft., has a typical chemical laboratory bench about 6 ft. long, with a central drain trough above which are shelves for apparatus and reagent bottles. At the end of

the trough is a rack for holding chemical-proof buckets, into which can be discharged solutions that may damage the ship's drainage system. This room also contains a sink with fresh-water taps for washing glassware, lockers and shelves, and another laboratory bench situated under a section of the main companionway trunk where apparatus up to 6 ft. in height may be installed. All the laboratories are equipped with an adequate number of 115-volt, D.C. electric outlets. On each side of the bench in the forward laboratory there are two folding seats surfaced with mason-

Figure 9 gives a picture of the "E. W. Scripps" off La Jolla in May, 1939.

Since the above description was prepared, the following changes have been made:

Construction and Design. - In the fall of 1939 the bowsprit was cut off and the forward rail was built up to approximately 18 inches higher at the stem and tapering back to 6 1/2 inches higher at the forerigging.

Rigging. - In the fall of 1939 the foregaff was removed and the foresail was cut to a leg-of-mutton sail.

Deck Fittings. - In July, 1941 the skylight aft of the dredging winch was replaced by a solid trunk. In the forward third of the trunk where the batteries are stowed, small ventilators were placed on top of the trunk. In the after two-thirds of the trunk were placed ventilators for the engine room and saloon. The skylights over the galley were replaced by solid trunks with portholes.

Machinery. - In August, 1940 the Winton diesel engine was replaced by a 170-HP Gray marine diesel engine, the exhaust of which discharges through a short straight pipe passing through the engine-room trunk. Engine-room controls were installed in the wheelhouse.

PRELIMINARY DISCUSSIONS

RESULTS IN PHYSICAL OCEANOGRAPHY

By

RICHARD H. FLEMING

Tables A and B, contained elsewhere in this report, give interpolated values based on the physical and chemical observations obtained by the "E. W. Scripps" on six cruises off the coast of southern California in 1938. Charts show for each cruise the topography of the 0- and 200-decibar surfaces relative to the 500-decibar surface and the distribution of temperature and salinity at the surface and at depths of 50 and 200 meters. Additional charts show the dissolved-oxygen content at 200 meters and, for Cruises I, II, and III, the phosphate-phosphorus distribution at 50 meters. These charts will be briefly discussed, but a detailed examination of the observations will be postponed. Since the chief purpose of this investigation was to determine the nature of the annual cycle, the charts for the six cruises dealing with the same observations will be discussed together.

Surface currents. - The dynamic height anomalies of the surface relative to the 500-decibar surface are shown for the six cruises in charts 1 to 6. The contours have been drawn for intervals of one dynamic centimeter and the arrows indicate the direction of flow. The inset diagrams show the theoretical relation of the distance between the contours to the velocity.

The results of the "Bluefin" investigations in the spring and early summer of 1937¹ showed that the current in the offshore area was directed to the southeast. This current had a tendency to flow in the direction of the coastline to the north of Point Conception and then to deviate from the coast to the south of this point. Inside of the flow to the southeast, which can be considered as part of the California Current, was found a flow in the opposite direction which was called the Southern California Counter Current. In March, May, and June, 1937, this Counter Current reached only as far north as the Channel Islands. There, or to the southeast of the Channel Islands, the Counter Current turned around and followed the coast as an inshore current to the southeast. The Counter Current may be considered as part of two eddies, one cyclonic eddy which was usually centered near San Nicolas Island, and one anticyclonic eddy with its center near San Clemente Island.

Examination of charts 1 to 6 will show that in 1938 the currents had the same general charac-

ter as in 1937, but in several instances the Counter Current continued north past Point Conception and usually the pattern of flow was complicated by the presence of eddies of different sizes, particularly in the offshore area.

During Cruise I, February 15 to 25 (chart 1), the California Current was broken up by a series of large eddies. The topography indicates a general transport toward the southeast and an appreciable influx of water from offshore in the southwestern part of the area. A well-developed trough separated the offshore flow and the Counter Current, which at this time extended northward beyond Point Conception as a clearly defined current. The anticyclonic eddy southeast of San Clemente Island was also fairly conspicuous.

In comparison with the other charts, that for Cruise II, April 8 to 12 (chart 2), appears extremely simple, but this may be because of the fact that the representation is based on observations from only the northern and southern lines. However, the observations show no indication of the Counter Current, which on Cruise I was clearly demonstrated by the data from these two lines. There was a general flow toward the southeast covering the whole area, with some inflow from the west in the southwestern part.

The surface topography for Cruise III, June 7 to 16 (chart 3), shows that the California Current had increased in velocity and that the Counter Current was again present, but only in the southeastern part of the area. A trough extended southward from Point Conception but there was no indication of a flow to the north past Point Conception. The band of high velocities in the California Current is comparable to similar bands found on the second and third "Bluefin" cruises in May and June, 1937² and can, like these, probably be ascribed to the effect of transport of light surface water away from the coast by the prevailing northwesterly winds. The band of high velocity occurred along the boundary separating the warm and light offshore water from the colder and heavier upwelled water.

The surface topography for Cruise IV, August 16 to 26 (chart 4), shows an extremely irregular pattern of flow in the offshore area. There was no net transport of water to the southeast and the high velocities appear to be associated with large eddies. It is also interesting to note that instead of inflow from the west in the southwestern part of the area, there was at this

¹H. U. Sverdrup and R. H. Fleming, "The Waters off the Coast of Southern California, March to July, 1937," *Bull. Scripps Inst. Oceanog.* (1941), vol. 4, no. 10, pp. 261-378.

²*Ibid.*

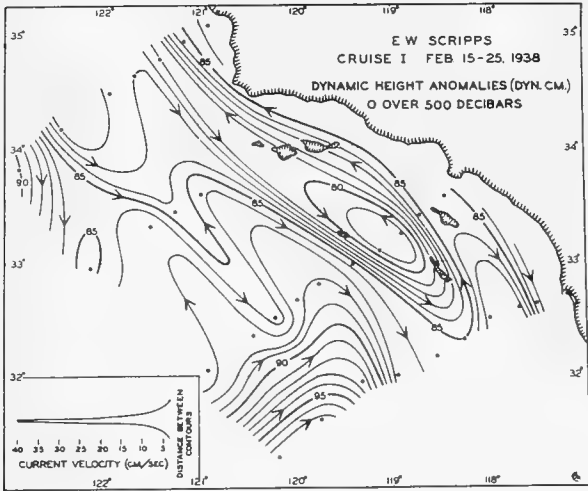

1

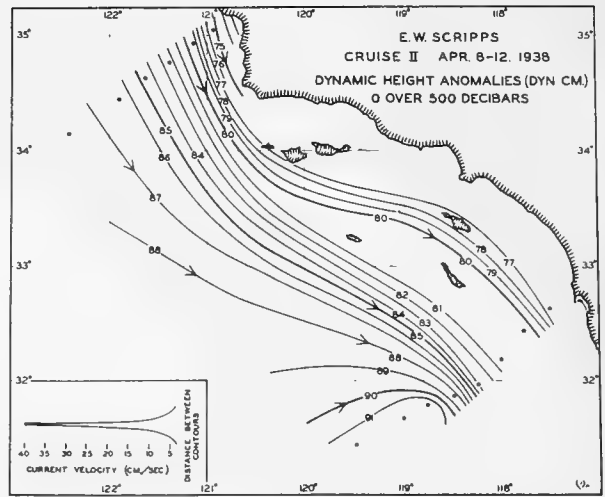

2

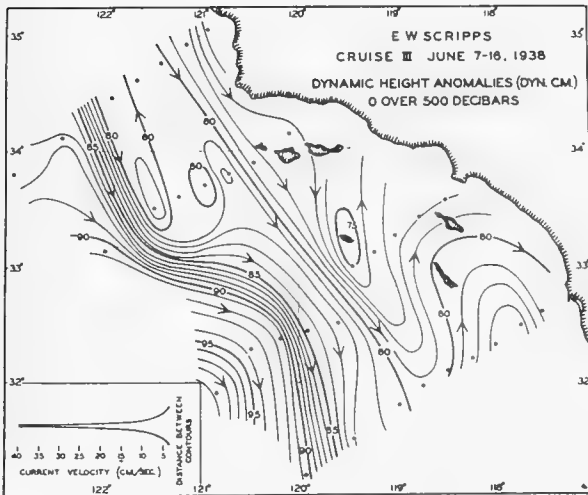

3

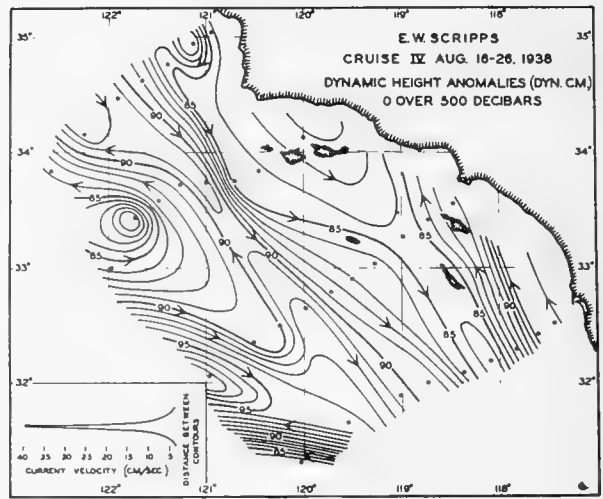

4

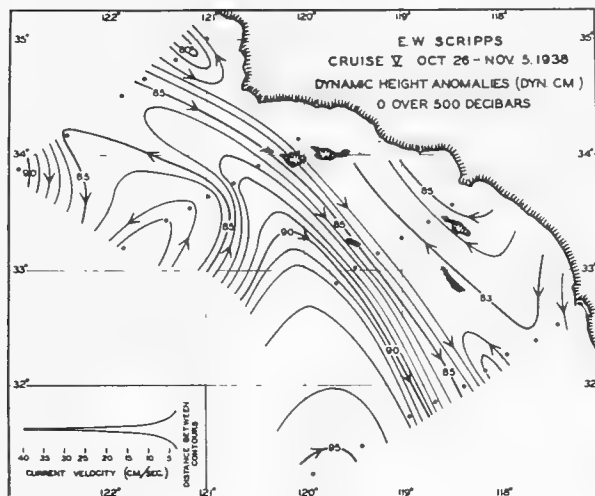

5

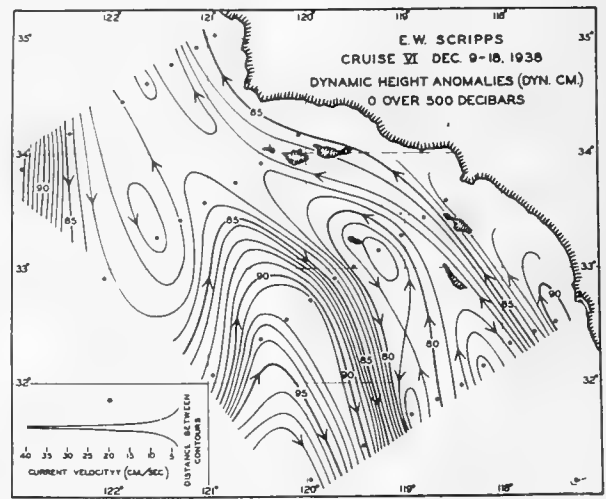

6

Charts 1-6.--Dynamic height anomalies, 0 over 500 decibars.

time a current in the opposite direction. The Counter Current was well developed, but from our observations it is not possible to decide whether this flow extended northward all along the coast or whether it turned southward again to form an anticyclonic eddy.

The surface topography for Cruise V, October 26 to November 5 (chart 5), is based upon an incomplete series of observations, since the third section was not finished. The general flow toward the south and east offshore was again modified by the inflow of water from the west. Although this water was ultimately carried away to the southeast, there is some indication of a northerly branch. Near shore there are several eddies which indicate a flow toward the northwest, but the flow has not the character of the fully developed Counter Current shown in the other charts.

The surface topography for Cruise VI, December 9 to 18 (chart 6), bears a striking resemblance to the data obtained on Cruise I, which indicates that there may be a rather clearly defined pattern in the annual cycle. Once again there was a general southeasterly flow offshore separated from the Counter Current by a trough line. The Counter Current extended northward beyond Point Conception as a well-defined flow. There was inflow from the west in the southwestern part similar to that encountered on most of the cruises.

From the results of these six cruises the variations in the surface circulation during 1938 may be described as follows: The pattern of flow is dominated by two currents flowing in opposite directions, namely, the California Current toward the southeast and the Counter Current toward the northwest. The nature of the circulation in the area covered by these investigations depends upon the relative development of these two currents. The presence of eddies of different sizes and probably of little permanency adds to the complexity of the pattern of flow as found on each cruise. During the winter months (charts 1 and 6) the Counter Current has its maximum development with the northward flow extending alongshore as far north as observations were made. During the winter months the part of the California Current represented by the southeasterly flow offshore is poorly developed, except in the southern part of the area where it is augmented by an inflow from the west. This inflow is greatest during the winter months. With the greater development of the northwest winds during the spring months the California Current increases in extent and velocity. As a result, the Counter Current is reduced or disappears entirely (chart 2). Following the period of maximum development of the California Current during the spring, there is a progressive breakdown of the southeasterly flow and a re-establishment of the Counter Current. The presence of numerous eddies in the offshore area indicates that the flow must be extremely unstable.

The Counter Current has its greatest development during the winter months when it extends northward beyond Point Conception. Frequently a part of the Counter Current turns inshore and the flow is again to the south near the coast of southern California, as shown in charts 3 and 6.

The California Current and the Counter Current are separated by a trough line which extends south-eastward from the vicinity of Point Conception. During the winter this runs some distance to the west of Point Conception but with the onset of the northwest winds in the spring it moves in toward the coast. During the spring and summer this trough line represents a divergence and is the zone of active upwelling, particularly near the coast.³

Currents at 200 meters. - For each of the six cruises the detailed topography of the 200-decibar surface relative to the 500-decibar surface is shown in charts 7 to 12. Even at this depth the pattern of flow is complicated and subject to variation. The southeasterly offshore current is not clearly defined or may be entirely absent, but there is always some transport to the north near shore. It is this northerly flow, termed the Coastal Deep Current,⁴ which brings in southern water of a higher salinity and a lower oxygen content than those of the water found in the offshore area. The trough line has been shown to be a zone of active mixing. There is some similarity between the flow at the surface and at 200 decibars, but even on Cruise II, when there was no indication of the Counter Current at the surface, there was a northerly flow at this lower level. No annual cycle could be detected in the currents at this level.

Temperature and salinity distribution at the surface. - The distribution of temperature and salinity at the surface for each of the six cruises is shown in charts 13 to 18. The temperature distribution is always characterized by a tongue of relatively cold water extending south and east from the coastal area to the north of Point Conception. The extent and location of this tongue varies during the course of the year and in general corresponds to the trough separating the flow to the south from the Counter Current system. On all cruises the lowest temperatures were found near Point Conception and the highest temperatures in the offshore water and in the Counter Current off San Diego. The maximum and minimum temperatures encountered on each cruise and the stations at which they occurred are given in table 2. The location of the stations may be obtained by referring to figure 1 in the introduction to this report. During the spring and summer months the highest temperatures occurred off San Diego, but during the remainder of the year they were found in the southwestern part of the offshore area.

³Ibid.

⁴Ibid.

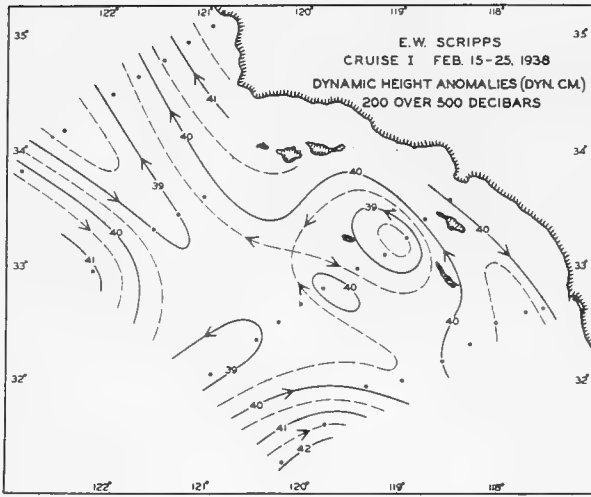

7

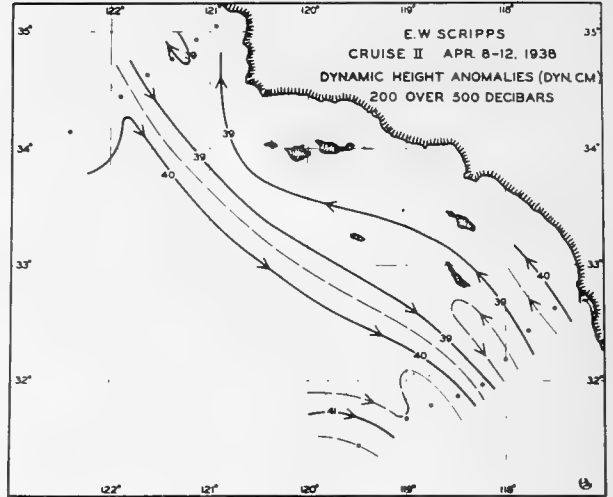

8

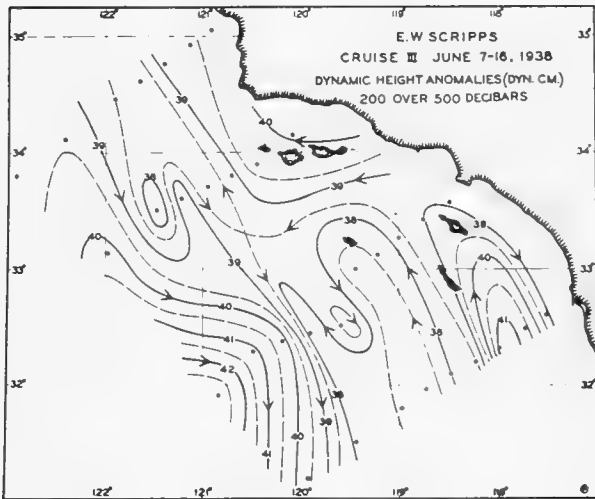

9

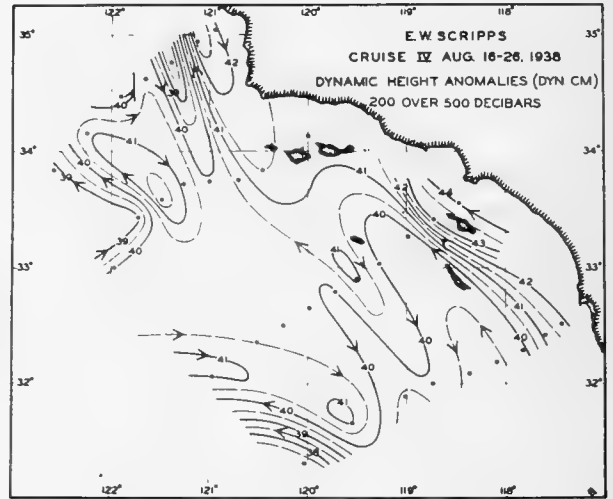

10

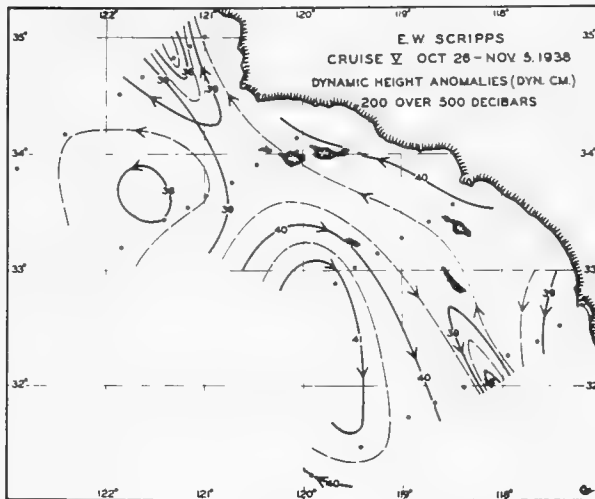

11

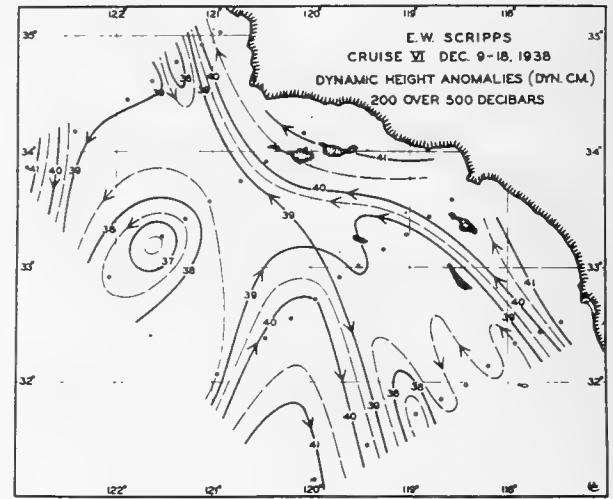

12

Charts 7-12.--Dynamic height anomalies, 200 over 500 decibars.

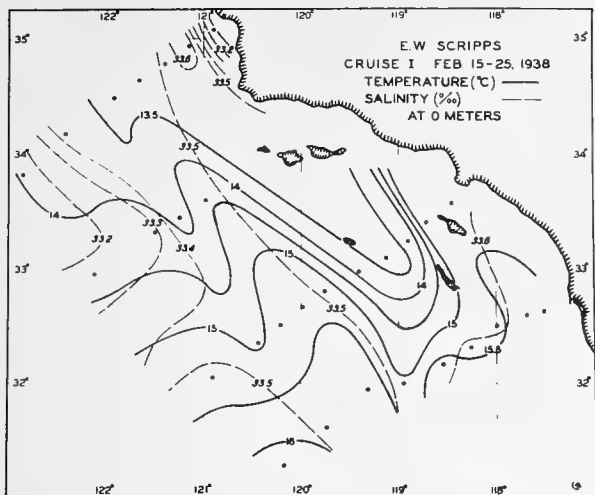

13

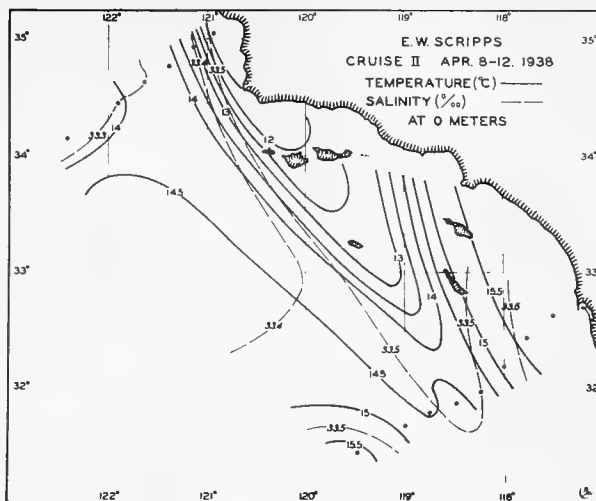

14

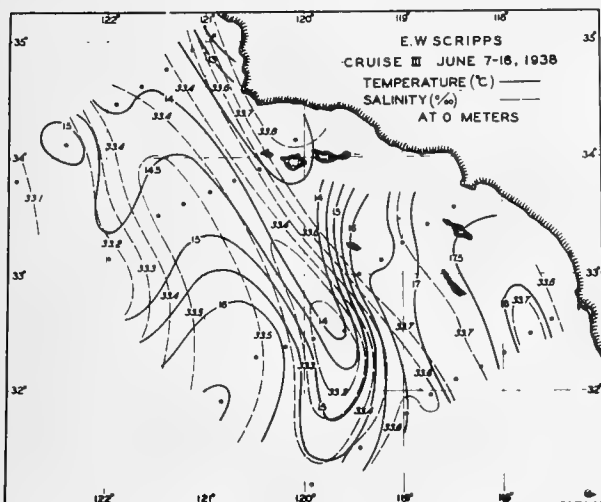

15

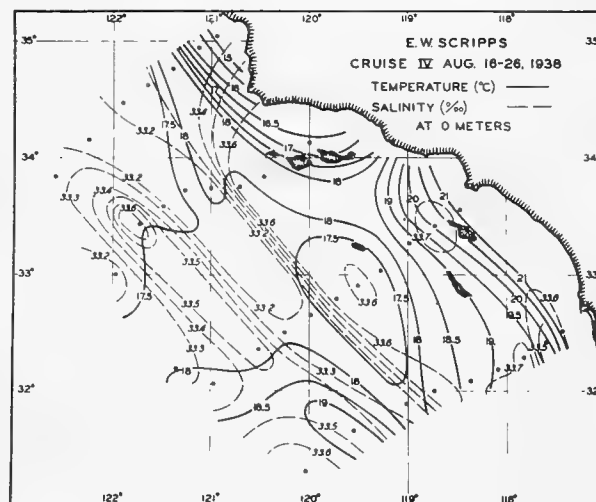

16

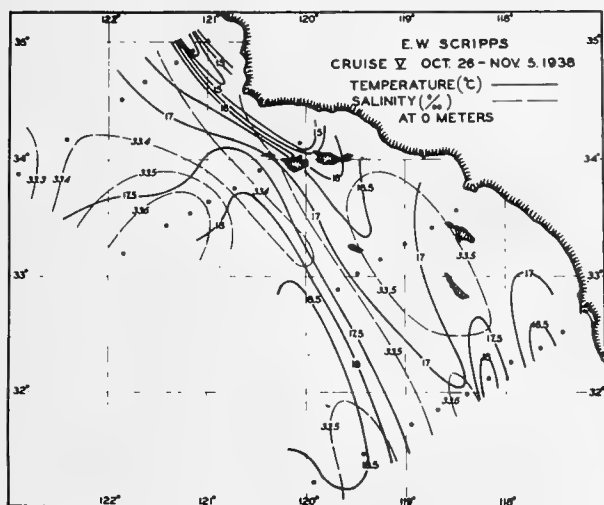

17

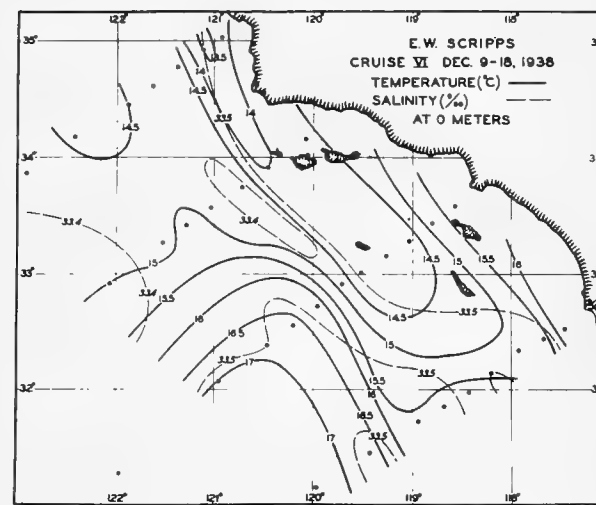

18

Charts 13-18.--Temperature-salinity at surface.

TABLE 2
 MAXIMUM AND MINIMUM TEMPERATURE AND SALINITY AT 0, 50, AND 200 METERS
 AND DISSOLVED OXYGEN AT 200 METERS

Depth (m.)	Values	Cruise I (30 stations)	Cruise II (14 stations)	Cruise III (33 stations)	Cruise IV (34 stations)	Cruise V (29 stations)	Cruise VI (33 stations)
TEMPERATURE (deg. C.)							
0 m...	Max.	16.47 (24)*	15.80 (31)	18.39 (30)	21.26 (31)	18.40 (24)	17.30 (24)
	Min.	13.17 (1)	11.30 (1)	12.35 (1)	14.75 (1)	13.93 (2)	13.50 (2)
	Range	3.30	4.50	6.04	6.51	4.47	3.80
50 m...	Max.	15.90 (24)	14.40 (25)	15.35 (23)	16.67 (23)	18.35 (25)	17.17 (24)
	Min.	10.50 (23)	9.70 (1)	9.88 (13)	10.91 (15)	10.87 (3)	10.15 (18)
	Range	5.40	4.70	5.47	5.76	7.48	7.02
200 m...	Max.	9.40 (31)	9.02 (30)	9.25 (29)	9.37 (31)	8.77 (25)	9.13 (31)
	Min.	7.75 (23)	7.73 (6)	7.43 (25)	7.53 (24)	7.45 (4)	7.48 (27)
	Range	1.65	1.29	1.82	1.84	1.32	1.65
SALINITY (‰)							
0 m...	Max.	33.64 (15)	33.68 (31)	33.82 (13)	33.74 (9)	33.65 (9A)	33.59 (27)
	Min.	33.16 (7)†	33.29 (6)	33.09 (7)	33.13 (6,10)	33.23 (7)	33.38 (8)
	Range	0.48	0.39	0.73	0.61	0.42	0.21
50 m...	Max.	33.66 (18)	33.88 (31)	33.86 (13)	33.69 (13)	33.68 (28A)	33.74 (27)
	Min.	33.17 (7)	33.30 (5)	33.09 (8)	33.01 (5)	33.11 (11)	33.22 (11)
	Range	0.49	0.58	0.77	0.68	0.57	0.52
200 m...	Max.	34.30 (31)	34.28 (31)	34.30 (18)	34.24 (9)	34.13 (28A)	34.15 (11)
	Min.	33.86 (24)	33.86 (25, 27)	33.76 (23)	33.89 (6)	33.93 (24)	33.84 (24)
	Range	0.44	0.42	0.54	0.35	0.20	0.31
DISSOLVED OXYGEN (ml/L)							
200 m...	Max.	3.15 (20, 24)	3.26 (25)	4.04 (23)	3.25 (5, 23)	3.56 (24)	3.63 (24)
	Min.	1.12 (31)	0.87 (31)	0.87 (18)	1.10 (12, 9A)	1.40 (12)	1.62 (27A)
	Range	2.03	2.39	3.17	2.15	2.16	2.01

*Figures in parentheses indicate stations.

†Salinity at station 1, 33.10 ‰.

The maximum and minimum salinity for each cruise is given in table 2, from which it is seen that the variation is rather small. Minimum values were always encountered in the offshore water with the exception of Cruise I, when water of low salinity, apparently diluted by rainfall and runoff, was found to the north of Point Conception. The maximum salinities were usually associated with low temperatures and were located in or near the trough. The surface salinity in the Counter Current was generally intermediate between that of the offshore water and that of the upwelling water. The pattern of distribution on any one cruise was frequently complicated by the presence of eddies which had transported water of one type into that of a different character. The latter statement applies to the conditions at other levels as well as at the surface.

Temperature and salinity at 50 meters. - The distribution of temperature and salinity at 50 meters for each of the six cruises is shown in charts 19 to 24. The extreme values and the ranges in conditions are given in table 2. At this level the distribution of conditions is more complicated than that at the surface, owing to the greater range in temperature and salinity. The greater range may be attributed to the fact that the convection layer varied from depths considerably less than 50 meters to more than 100 meters. The convection layer was generally thickest in the offshore area, within which the temperatures at 50 meters were therefore similar to those at the surface. Near shore the convection layer was thin and, consequently, low temperatures were found at 50 meters. Lowest temperatures and highest salinities were usually found in or near the tongue extending south and east

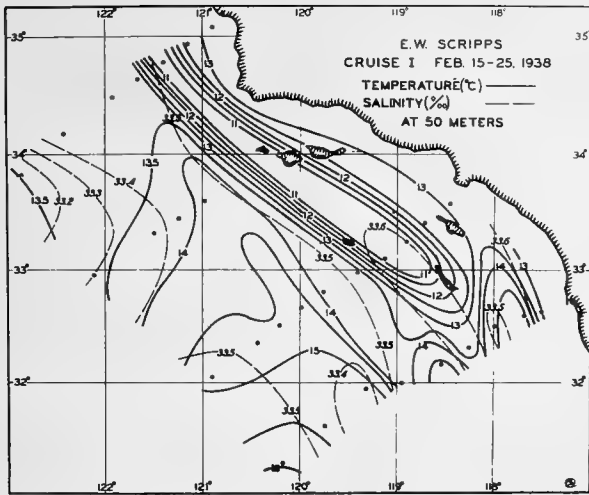

19

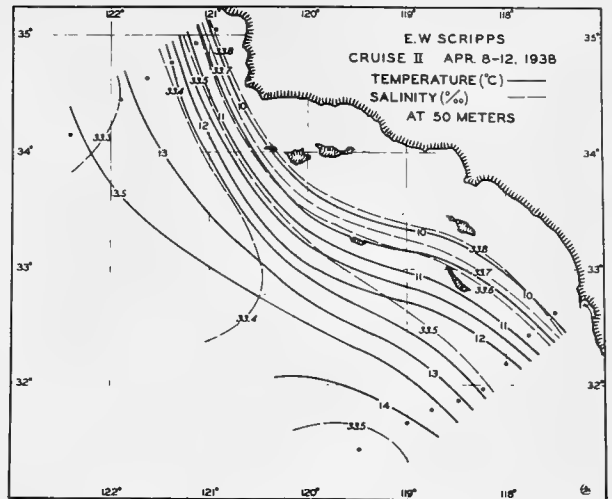

20

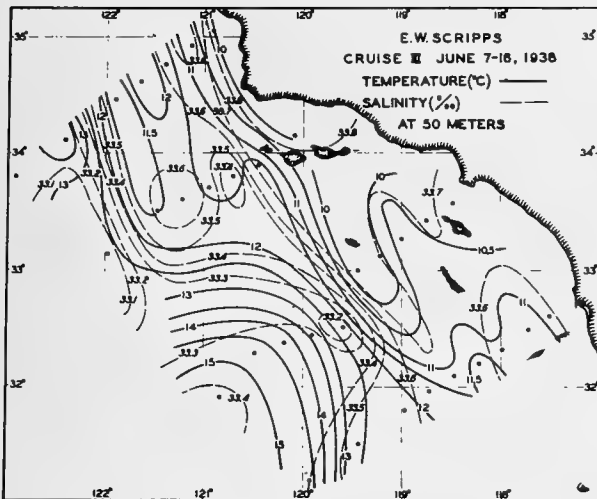

21

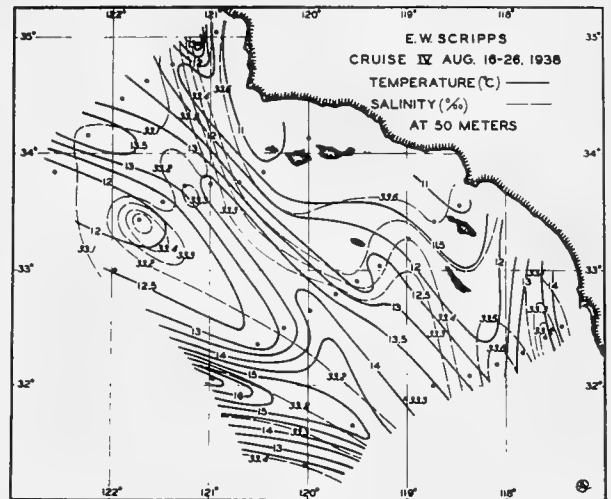

22

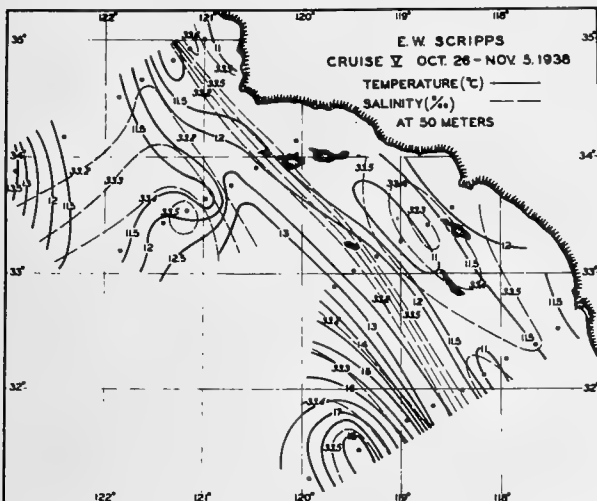

23

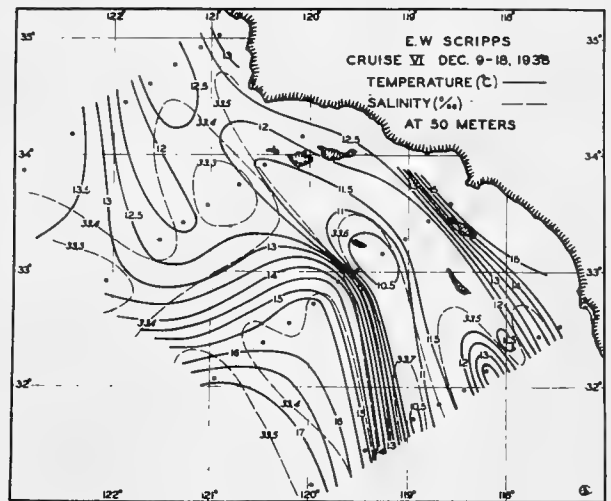

24

Charts 19-24.---Temperature-salinity at 50 meters.

from Point Conception and corresponding to the trough line. Maximum temperatures and minimum salinities were always located in the offshore area and a secondary temperature maximum occurred off San Diego.

Temperature and salinity distribution at 200 meters. - The temperature and salinity distribution at 200 meters for each of the six cruises is shown in charts 25 to 30. The extreme values and the ranges in conditions are given in table 2. The pattern of distribution in each instance is rather complicated but the range in temperature and salinity is much less than at the higher levels. The most marked difference at this level is that the minimum temperatures are now associated with minimum salinities, usually in the offshore area, whereas maximum temperatures and salinities always occur in the Counter Current system. Sometimes this generalization does not hold, because of the transport of water of one character into that of another type. Since the seasonal climatic cycle cannot be directly effective at this depth, the fluctuating conditions must be ascribed to the shifting currents.

Dissolved oxygen content at 200 meters. - The distribution of dissolved oxygen at a depth of 200 meters for each cruise is shown in charts 31 to 36. The extreme values and the range encountered on each cruise are given in table 2. The minimum values were always found in the Counter Current or in the trough. Occasionally isolated minima, associated with eddies, occurred in the offshore water. The low oxygen content inshore is a characteristic of the water of the Coastal Deep Current, as shown by Sverdrup and Fleming.⁵ The maximum values for dissolved-oxygen content always occurred in the offshore water and generally in the southwestern part of the area examined.

Phosphate content at 50 meters. - The dissolved-inorganic-phosphate content found on Cruises I, II, and III, at a depth of 50 meters is shown in charts 37 to 39. The values are given as microgram-atoms per kilogram. The pattern of distribution in general follows that of the temperature, indicating that upwelling is the chief process bringing phosphate to the surface layers. Maximum values were always found north of Point Conception and in the trough line extending south and east. Minimum values always occurred in the offshore water and generally in the southwestern part of the area examined. The highest value was found off Point Conception on Cruise III, showing that the upwelling provided a plentiful supply of nutrients during the vegetative season.

Currents and the distribution of properties. - Since the dynamic topography depends upon the distribution of density, one must expect a parallelism between the streamlines and the horizontal distribution of

the isotherms and isohalines, especially of the former. That such an agreement exists may be seen when the surface topography for any cruise is compared with the corresponding temperature distribution at 50 meters. Changes in the pattern of flow between cruises are similar to the changes in the distribution of temperature and salinity. Since fluctuations occurred at depths below the zone of direct influence of the local external climatic factors, it seems reasonable to attribute the major part of the changes in conditions to variations in the pattern of flow rather than vice versa. Parts of the changes in the currents may be due to local factors such as the winds, but others are probably brought about by agencies operating beyond the area covered by our investigations.

The cyclic changes in conditions which might be expected to occur during the course of the year are obscured and complicated by a number of factors. The area covered by these investigations is one of large variations in the lateral distribution of temperature, salinity, oxygen, and probably other components. This is due partly to the gradients associated with the flow, but chiefly to the effect of upwelling and to the different character of the subsurface water in the offshore area and in the Coastal Deep Current near the coast. Consequently, the changing currents carry with them water of widely differing character and, in addition to the changes caused by the shifts in the circulation, lateral mixing and the breaking away of eddies lead to a very complicated pattern which to a great degree obscures any annual cycle.

Near the coast upwelling tends to reduce the temperature and to increase the salinity in the surface layers. The upwelling is most active during the spring and early summer months and tends at that time to lower the temperatures when normally there should be warming of the surface layers. From the data in table 2 it is seen that at 0 and 50 meters minimum temperatures always occurred near Point Conception and in or near the trough, and that the annual range of the minima was much less than the range of the maxima. That is to say, in the area off Point Conception and toward the southeast, the upwelling tends to maintain low and rather uniform temperatures whereas the temperature in the offshore area and in the Counter Current system are rising.

Part of the complexity of the distribution of properties is due to eddies which transport water of one type into that of another type. These eddies are apparently associated with the shifting currents or result from the instability of the current system. These eddies are frequently of such small dimensions that they were only detected at single stations. Consequently the complexity of the distribution shown in the charts depends to an appreciable degree upon the fact that the observations were obtained at a relatively large number of closely spaced stations.

⁵Ibid.

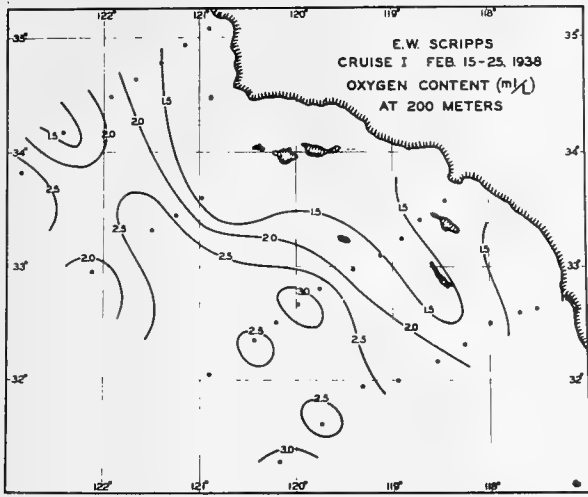

25

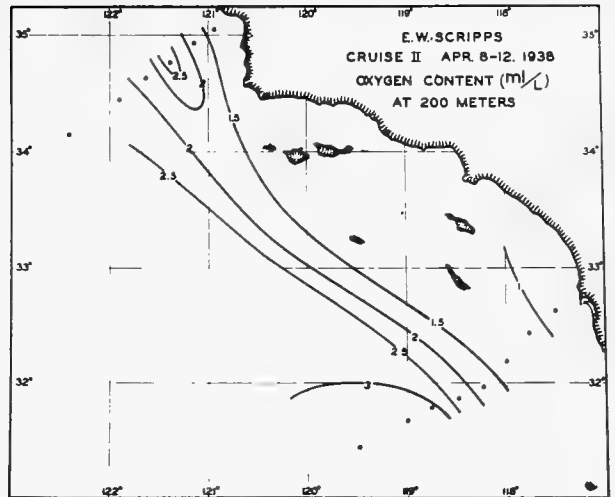

26

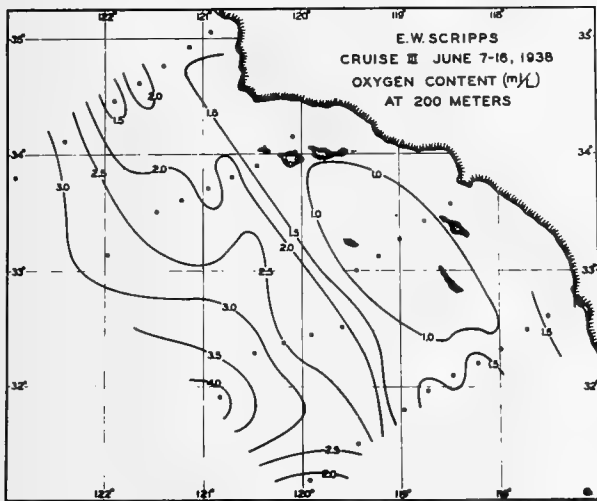

27

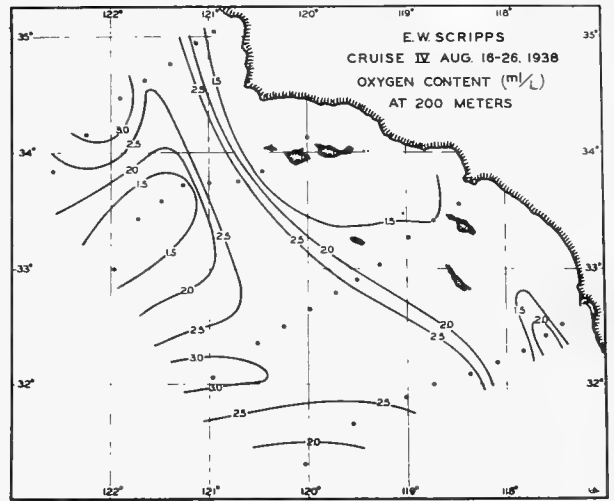

28

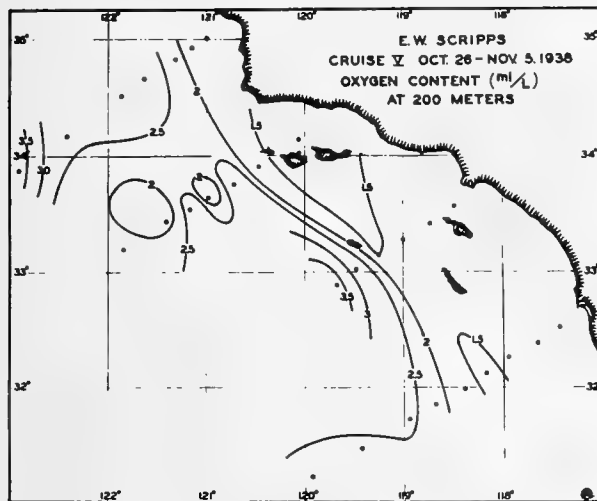

29

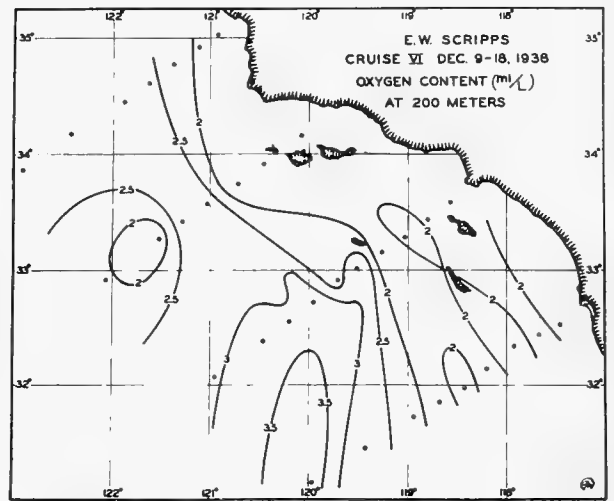

30

Charts 25-30.--Temperature-salinity at 200 meters.

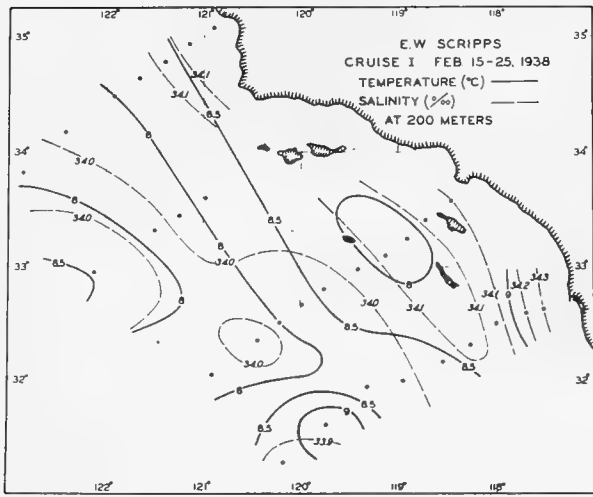

31

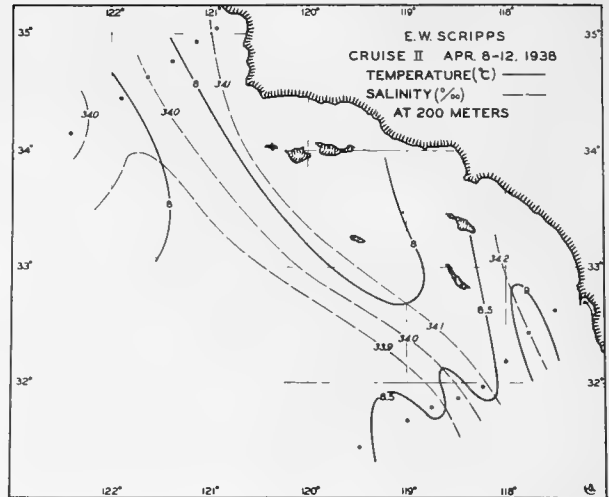

32

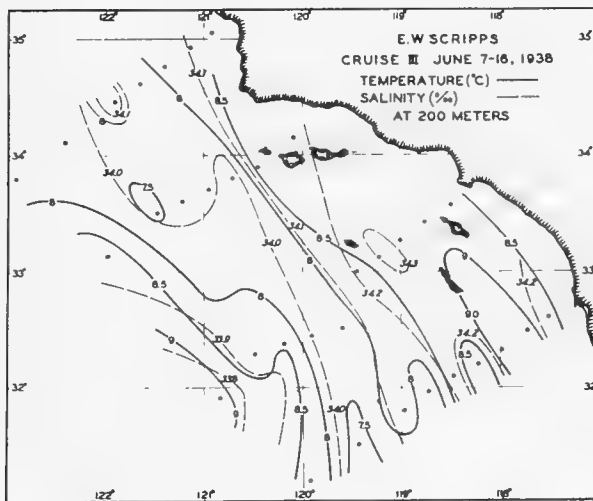

33

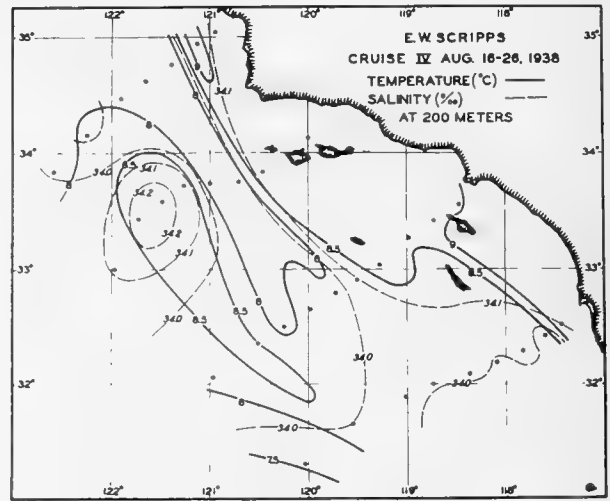

34

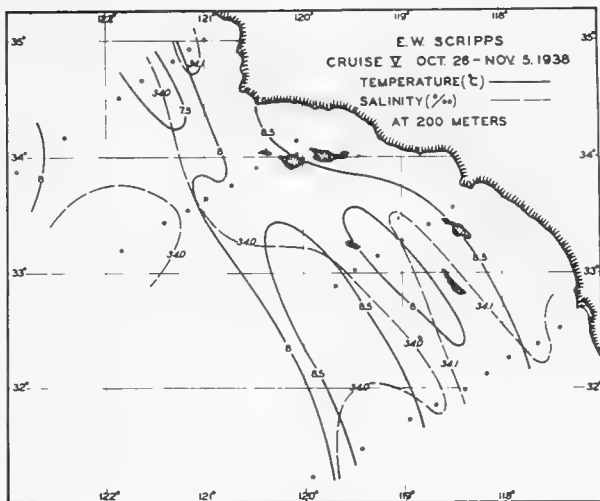

35

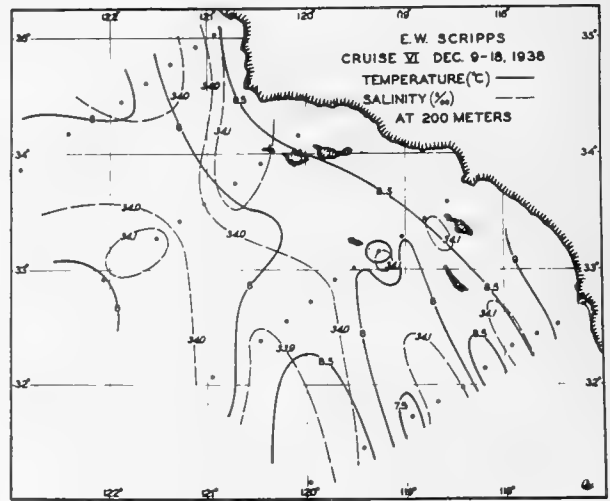

36

Charts 31-36.--Oxygen content at 200 meters.

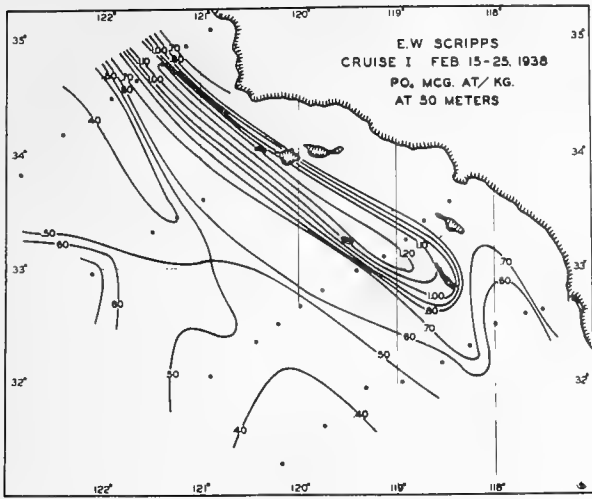

37

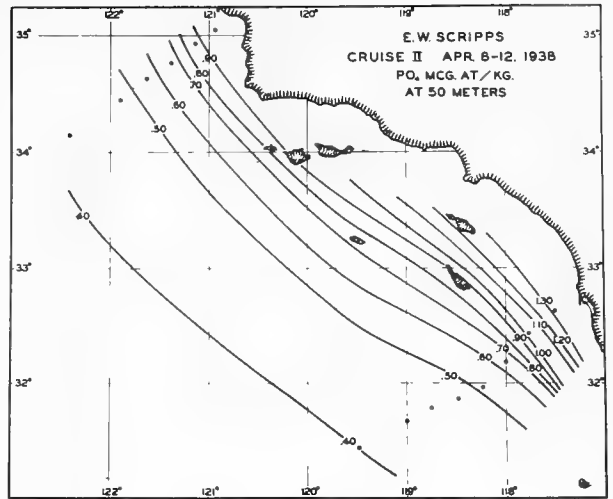

38

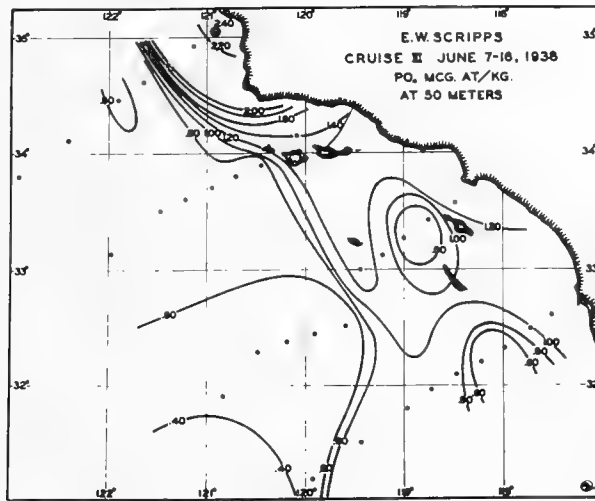

39

Charts 37-39.--Phosphate phosphorus at 50 meters.

Owing to the complexity of the pattern one can evidently not expect to find a repetition of identical conditions each year. Examination of the charts of the distribution of temperature and salinity at the surface, at 50, and 200 meters, and of the dissolved oxygen at 200 meters shows, however, that the general pattern is the same for all cruises although the absolute values vary. Therefore, emphasis can be placed on the maximum and minimum values contained in table 2. The location of the stations indicated in this table can be found in figure 1 in the introduction to this report (facing page 1).

It follows from the foregoing discussion that the area covered by these investigations may be roughly divided into three zones: First, the Offshore Zone, where there is generally a flow toward the south or southeast. In this area the surface temperatures are, as a rule, relatively high and the salinities low, and the convection layer is thick. Second, the Trough Zone, extending south and east from the area north of Point Conception. This represents the zone separating the southeasterly flow from the Counter Current flowing toward the north. Within this zone upwelling, particularly during the spring and summer months, maintains low temperatures and relatively high salinities in the surface layers, and the convection layer is thin. Third, the Counter Current or Coastal Zone, where there is flow either toward the north or, close to the shore, toward the south. Except in winter this zone does not extend farther north than Point Conception and in spring it may be entirely lacking. In this zone the surface temperatures are again relatively high and the salinities are intermediate between those of the other two zones. The convection layer is usually rather thin.

It will be seen that these zones are not geographical but that they depend upon the pattern of flow. Consequently, individual locations may be under the regime of different zones at different times of the year. However, on the basis of this division into zones, a fair estimate of the distribution of conditions can be derived from the pattern of flow. On the other hand, if the temperature distribution in the upper layers, say, down to a depth of 100 meters, is known, a very good idea of the pattern of circulation can be obtained.

In conclusion, some suggestions are presented with respect to the possible character of the annual changes of the currents off the coast. The fact that the Counter Current is most conspicuous in winter when the winds are variable indicates perhaps that the inshore flow to the north represents a "normal" state which is developed in the absence of strong external influences. Perhaps the Counter Current, which, in winter, can be traced all along the coast of California, represents a counterpart to the inshore flow to the southeast along the east coast of the United States, on the left-hand side of the Gulf Stream. If this assumption is correct, the prevailing northwest winds in spring and early summer bring about "abnormal" conditions which are caused by the upwelling along the coast. When the external influence of the wind decreases, large eddies develop (fig. 4), but gradually the "normal" state is reestablished.

The fact that below 200 meters the Counter Current appears to be equally well developed in all seasons perhaps supports the conclusion that the Counter Current represents a "normal" feature which in the upper layer is disturbed by the prevailing winds of the spring and early summer.

DIATOMS

By

W. E. ALLEN

Throughout the six cruises of 1938 (February, April, June, August, October, December) not only was the group of diatoms far the most prominent in catches of phytoplankton, but the representation of other groups was negligible to about the same degree. Even though such forms as coccolithophores and smaller dinoflagellates may have been lost excessively through the meshes of the filtration net (200 meshes to linear inch), their presence should have been observable if their abundance had been great at any time. Therefore, it appears reasonable to assume that attention to diatoms is sufficient for present purposes and that other groups represented in the phytoplankton may be neglected.

After microscopic examination of the 1130 catches of phytoplankton I felt most impressed with the fact that diatoms were represented in all sections at all seasons. Even in those catches yielding numbers too small for statistical significance there were enough specimens to constitute an important source of supply for production or renewal of large populations under favorable conditions. In the region investigated, taken as a whole, nearly two-thirds of the catches showed numbers of 500 diatom cells per liter, or more. The line about one hundred and forty miles southwest from the vicinity of Santa Barbara showed greatest consistency in producing significant numbers, more than two-thirds of the catches yielding 500 cells or more; but the northern line was nearly as good, with almost exactly two-thirds containing such numbers. The poorest line was the one southwest from Los Angeles Harbor, only a few more than one-third of the catches reaching or exceeding the 500 mark.

There is no possibility of determining from existing data the true relationships between alongshore and offshore populations, but it is natural (and reasonable) to suppose that there is a fairly close correspondence of periods of increase and decrease in abundance. Uncompleted manuscript records of surface catches made daily at two shoreline stations (Point Hueneme near Santa Barbara and La Jolla near San Diego) indicate that all but one (November) of the six cruises of 1938 were made in periods of decline of abundance or of a minimum abundance at these two stations. Obviously, the noteworthy or large numbers found in many catches offshore may have been remnants of still larger numbers in process of reduction, or they may have been derivatives of inshore populations in process of increase, or they may have been entirely independent in origin. In consideration of such wide differences in possibilities no positive conclusion can be completely acceptable at present. How-

ever, a tentative suggestion may be made that constancy of representation of diatom populations is to be more generally expected offshore throughout the whole year, irrespective of seasons.

At most offshore stations the abundance at the surface level was closely indicative of the size of the population total at any particular station. Therefore, comparison with shoreline surface catches is surely permissible. But, in any event, the clear showing of declining production at two stations inshore at the time of five out of six cruises constitutes warning that the problems of the range of either actual or potential annual productivity of offshore areas are still open questions. Nevertheless, the records do show that a number of offshore stations may yield phytoplankton abundantly.

As far as the data for these cruises are concerned, there is strong evidence that certain offshore areas are more productive, certainly more consistently productive than those near shore. An exception exists in the two stations near Santa Rosa and San Miguel Islands. Still, these two stations lack consistency, one showing extreme abundance in only one of the four times sampled, and the other showing insignificant numbers in one of the four times sampled. Of other stations within twenty-five miles offshore the two on the northern line showed numbers greater than those at stations more than fifty miles from shore in one out of six times sampled. Nearly the same statement applies to the stations near Los Angeles Harbor and to the two stations near San Diego.

As far as seasonal differences in production of diatoms is concerned, the evidence from the six cruises seems fairly clear and corresponds very well with the data obtained in most years from daily catches at shore stations. Thus the largest abundance for the year was in April or June at most stations of the cruises. However, station 30 (near San Diego) showed largest numbers in October, and it is possible that certain other stations would have shown different times of maxima if they had been sampled on all six cruises. Such exceptions are sufficient to show that biological sequences through a year cannot be determined positively without a high degree of continuity of observation.

As has been suggested in a preceding paragraph, the surface level usually indicates fairly well conditions of abundance or lack of abundance of plankton diatoms at individual stations. However, data from this level are not fully reliable as indicators of greater or lesser abundance; they may be widely misleading if accepted as in-

dicators of total numbers for the station or for particular levels below the surface. These facts are well illustrated by the northern line where, in twenty-eight yields of significant numbers, there were only seven at which the surface numbers were as large as those at certain lower levels. In a few instances the numbers at a level below the surface were more than four times as large as those at the surface. Still it is true that the surface level held the lead in abundance a little more often than any other. The thirty-, forty-, and fifty-meter levels led

in abundance almost as often. Large abundance at any level was nearly always accompanied by abundances nearly as large at two neighboring levels.

At some time in the year more than thirty different species of diatoms, representing fourteen genera, were sufficiently prominent to rank among the leading five at one or more stations. There was no significant difference in the lists of names from different parts of the area surveyed, and the prominent forms were all well known from daily catches at shore stations.

NOTES ON ZOÖPLANKTON

By

MARTIN W. JOHNSON

Together with other oceanographic observations taken during the 1938 regular cruises (Cruises II to VI of the "E. W. Scripps" off the southern California coast), there were included also net collections for the animal plankton. These collections were taken with a regular Nansen closing net 3 meters long with an opening of 70 centimeters. The bolting cloth used in construction of the net was Nos. 000, 0, and 8.

It was originally planned to take vertical net hauls from 500 to 200 meters and from 200 to 0 meters at each station. However, as indicated below, this plan was carried out at only three stations of Cruise II. Because of the amount of time needed for the joint observations, it was necessary to eliminate the lower-depth hauls. Though collections from depths greater than 200 meters are highly desirable, it was deemed that most of the zoöplankton population would be sampled in the 200- to 0-meter hauls. Study of the bathypelagic population is, therefore, deferred for the time being.

A summary follows of the number of stations occupied for each cruise at which net collections were made. Occasionally the wind was too strong to operate the net at all of the scheduled stations, but for each cruise the stations were usually well distributed over the area included.

Cruise II, April 8-12...3 stations: 500-200 m.
and 200-0 m.

4 stations: 200-0 m.

(This cruise was not completed owing to storms.)

Cruise III, June 7-16...25 stations: 200-0 m.

Cruise IV, Aug. 16-25...34 stations: 200-0 m.

Cruise V, Oct. 26-Nov. 5...28 stations: 200-0 m.

Cruise VI, Dec. 9-18....27 stations: 200-0 m.

In addition to the above regular collections, some twenty surface hauls were made with small nets for collection of material for life-history studies.

Up to this time the collections have been only partially analyzed, and it is possible here to indicate only a few of the outstanding characteristics of the population as shown thus far.

Volumes. - In general, it may be said that the total volumes (when free from diatoms) of plankton caught at each station are characterized by being only moderately rich and rather uniform, especially for adjacent stations. The anomalies are not as a rule haphazard in appearance (fig. 10), but they indicate that extensive, sufficiently large, patches or streaks of zoöplankton exist in such a way that several stations may come to fall within a patch. It is difficult to relate

the volumes to the hydrographic features, though there is some indication that these general patches are perhaps drawn out in a general north-south direction more or less following the main contour of the currents.

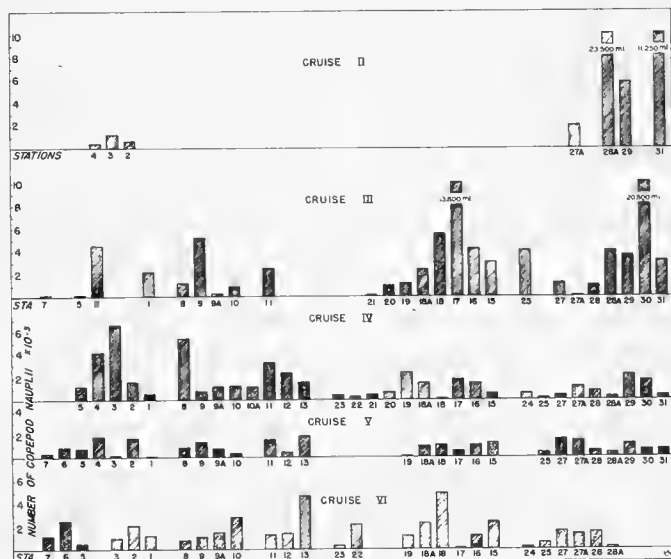

Fig. 10. Zoöplankton. Net haul volumes (displacement). Volumes higher than 15 ml. result from mixture of diatoms except at stations 28A, 29, and 31 of Cruise II, where zoöplankton constituted about 25.20 and 18 ml., respectively. Only the stations at which plankton samples were taken are shown.

During the April cruise only a few stations were occupied, but it will be seen that total volumes were high in the southern line. At station 28A this is chiefly owing to a mixture of diatoms which formed about half of the volume, as shown by laboriously separating them from the animals. At station 29 the volume is also influenced by diatoms but to a much lesser degree. The other stations had nearly clean zoöplankton.

The volumes of the June cruise are also conspicuously influenced by diatoms caught together with the animals. No attempt was made to separate the two in order to obtain a true volume of the animals. Where smaller volumes were taken, the catches were nearly pure zoöplankton. It may be stated here that, in making net collections, a dilemma is presented in deciding the appropriate mesh aperture to use in nets for general zoöplankton catches during periods of diatom outbursts. If apertures are sufficiently large to allow escape of diatoms, especially larger and filamentous

forms, the smaller copepods and nauplii also escape, and the first of these may at times bulk rather large. Also, the relative numbers of nauplii are important indications of the productive periods in the area (fig. 11).

In the remainder of the cruises diatoms occurred only in moderation and enter seriously into the bulk only where volumes are over 15 milliliters as measured by displacement.

The phytoplankton population will be more fully discussed in separate reports, but a few remarks should be made in passing. In general, the net catches support the findings on distribution and abundance as indicated by special study of diatoms. Three factors are brought out rather clearly. (1) The main diatom outbursts are indicated in April and June. During the remainder of the cruises only moderate numbers were taken in the net. (2) During the maximum "flowering" of diatoms, the phenomenon is not localized but occurs over nearly the whole area (except as indicated below), as shown by the June cruise. It would appear that the impulse had moved from south in April to the more northerly sections in the later cruises. (3) Only the stations situated inside the main southerly flow of water are productive, that is, the stations characterized by more or less mixed waters.

Composition of zoöplankton. - The zoöplankton is qualitatively very heterogeneous, with euphausiids, radiolaria, chaetognaths, Appendicularia, and various invertebrate larvae as important constituents. The animal plankton is, however, dominated by the copepods and the present report will be limited mainly to this group, of which at least 91 species in 45 genera were taken. Species not yet determined are counted as one, though in several instances the genus concerned is known to be made up of several local species, namely the genera *Corycaeus*, *Oithona*, and *Oncea*, together with a few microcalanids. Many, but not all, of the copepods have previously been recorded from this area by Esterly, but the following list, compiled only in the course of general plankton analysis, gives twenty-six species not previously found in this area (starred). At least seven of these are in genera not previously found off this coast.

Acartia { clausi
danae*
tonsa
Aegisthus mucronatus*
Aetideus giesbrechti*
Arietellus setosus
Calanus { finmarchicus
tenuicornis
Calocalanus { pavo*
tenuis*

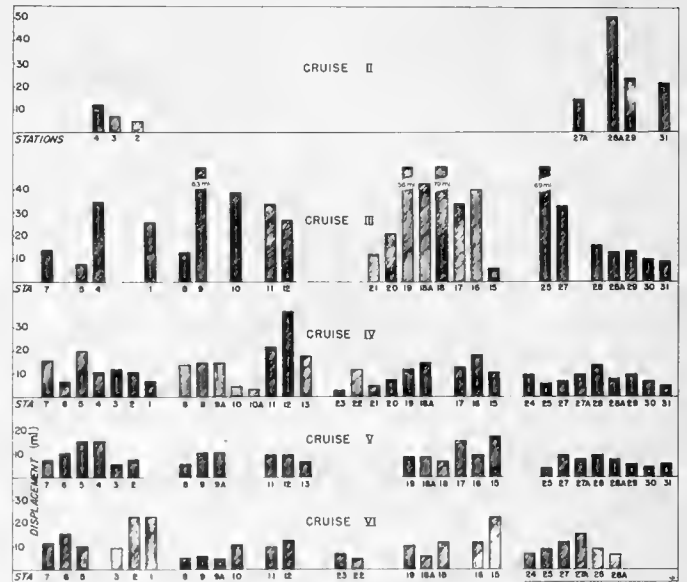

Fig. 11. Numbers of Copepod nauplii, 200- to 0-meter hauls. "E. W. Scripps" Cruises II-VI. Only the stations at which plankton samples were taken are shown.

Candacia { aethiopica
bipinnata
bispinosa*
curta
simplex*
tenuimana*
varicans*

Centraugaptilus { lucidus
porcellus*

Centropages { bradyi
violaceus*

Chirundina streetsi
Clausocalanus arcuicornis
Clytemnestra rostrata
Ctenocalanus vanus*
Copilia mirabilis*
Copilia sp.

Corycaeus { furcifer*
spp.

Euaugaptilus sp.*

Eucalanus { attenuatus
bungii californicus
crassus
elongatus
subtenuis

Euchaeta { acuta
elongata
media
propinqua
spinifera
spinosa

<u>Euchirella</u>	{	<u>curticauda</u>
		<u>galeata</u>
		<u>messinensis</u>
		<u>propria</u> *
		<u>pulchra</u>
	{	<u>rostrata</u>
<u>Euterpina acutifrons</u>		
<u>Gaetanus</u>	{	<u>secundus</u>
		<u>unicornis</u>
<u>Gaidius pungens</u>		
<u>Haloptilus</u>	{	<u>acutifrons</u> *
		<u>longicornis</u> *
		<u>ornatus</u> *
		<u>spiniceps</u> *
<u>Heterorhabdus</u>	{	<u>clausi</u>
		<u>longicornis</u>
		<u>papilliger</u>
<u>Labidocera</u>	{	<u>jollae</u>
		<u>trispinosa</u>
<u>Lophothrix frontalis</u>		
<u>Lubbockia (aculeata?)</u> *		
<u>Lucicutia flavicornis</u>		
<u>Macrosetella sp.</u> *		
<u>Metridia</u>	{	<u>atra</u>
		<u>boeckii</u>
		<u>lucens</u>
<u>Microsetella rosea</u>		
<u>Mormonilla</u>	{	<u>minor</u> *
		<u>phasma</u> *
<u>Oithona plumifera</u>		
<u>Oithonina nana</u>		
<u>Oncea conifera</u>		
<u>Oncea spp.</u>		
<u>Pleuromamma</u>	{	<u>abdominalis</u>
		<u>gracilis</u>
		<u>xiphias</u>
<u>Pontellopsis occidentalis</u>		
<u>Rhincalanus nasutus</u>		
<u>Sapphirina</u>	{	<u>angusta</u>
		<u>iris</u>
		<u>scarlata</u>
<u>Scolecithricella subdentata</u>		
<u>Scolecithrix danae</u>		
<u>Scottocalanus persecans</u>		
<u>Tortanus discaudatus</u> *		
<u>Undeuchaeta</u>	{	<u>bispinosa</u>
		<u>major</u>
		<u>minor</u>
<u>Vetтория granulosa</u> *		

Most of the species were represented at all stations on one or more cruises. A few were always widely distributed and were rarely absent from any station, though varying in numbers. Among these may be mentioned Eucalanus bungii californicus and Calanus finmarchicus and some unidentified microcalanids. Of the species most closely bound to the immediate coast may be mentioned Tortanus discaudatus, Oithonina nana, Acartia clausi, and A. tonsa. The more typically oceanic forms are Corissa parva, Acartia danae, Copilia mirabilis and Eucalanus elongatus. A few normally deep-water species came within reach of the net, for example, Aegisthus mucronatus. At no time was there evidence of any one species dominating markedly in numbers over all others, as is so characteristic at times in boreal waters. Calanus finmarchicus, the most important of the boreal Atlantic species, was only moderately numerous, competing with Eucalanus bungii californicus for first place numerically among the larger copepods. This was perhaps to be expected, since it appears that in the open waters of the Northwest Pacific from the Bering Sea southward, C. finmarchicus has also for the most part relinquished its place to other members of the same genus, namely, C. tonsa and C. cristatus, and to the two varieties of Eucalanus bungii. A heterogeneous group of small copepods lumped as "microcalanids" and Oithona spp. were numerically most abundant of all the copepods. Unidentifiable immature calanoids were also very abundant.

In general, the stations situated about midway between the outer and inner ends of the sections, that is, the stations falling within the zone generally characterized by mixed water, show the greatest numbers of individuals of the numerically important species such as C. finmarchicus, E. bungii californicus, and the "microcalanids."

There is marked evidence of copepod reproduction throughout the period investigated (April to December), but the greatest number of nauplius larvae were taken in April and June at stations along the southern sections. In August the greatest numbers occurred along the northern sections. In October the numbers had fallen off but some increase was again indicated for December at some stations.

OCEANOGRAPHIC OBSERVATIONS, 1938

TABLE A

Table A contains interpolated values of temperature, salinity, and oxygen at standard depths, and computed values of σ_t , specific volume anomaly, δ , and anomaly of dynamic depth, ΔD .

Interpolated and Computed Values

Cruise I

Depth (m.) (dbars)	Tempera- ture (°C.)	Salin- ity (°/oo)	Oxy- gen (ml/L.)	σ_t 10 ⁵ δ	ΔD (dyn. m.)	Depth (m.) (dbars)	Tempera- ture (°C.)	Salin- ity (°/oo)	Oxy- gen (ml/L.)	σ_t 10 ⁵ δ	ΔD (dyn. m.)
Station 1. February 15, 1938; 1030. Lat. 35°05'N, long. 120°54'W. Wind: -. Sea: smooth						Station 4. February 15, 1938; 2300. Lat. 34°39'N, long. 121°40'W. Wind: -. Sea: moderate					
0	13.17	33.10	3.39	24.91	306	0	13.37	33.46	5.92	25.14	283
10	13.18	33.46	2.61	25.18	280	10	13.30	33.43	5.70	25.13	284
25	13.24	33.54	2.88	25.24	275	25	13.30	33.42	5.70	25.13	285
50	13.11	33.53	3.14	25.25	274	50	13.20	33.45	5.35	25.17	282
75	12.31	33.63	3.09	25.48	252	75	10.85	33.53	4.15	25.67	234
100	11.38	33.66	2.53	25.68	234	100	9.80	33.81	2.90	26.07	196
150	8.78	33.97	1.81	26.36	168	150	8.80	33.98	2.05	26.37	169
200*	8.57	34.01	26.43	162	200	8.20	34.02	26.50	158
						250	7.75	34.06	26.59	150
						300	7.35	34.13	26.70	139
						400	6.50	34.22	0.60	26.89	122
						500	5.73	34.26	0.42	27.02	111
Station 2. February 15, 1938; 1400. Lat. 34°56'N, long. 121°09'W. Wind: NW 3-4. Sea: heavy						Station 5. February 16, 1938; 0400. Lat. 34°29'N, long. 121°56'W. Wind: WNW 3-4. Sea: moderate					
0	13.27	33.64	4.35	25.30	268	0	13.42	33.43	5.84	25.11	286
10	13.13	33.63	2.81	25.32	266	10	13.08	33.45	5.82	25.19	278
25	13.12	33.63	4.83	25.32	266	25	13.10	33.43	5.75	25.17	281
50	12.97	33.58	2.54	25.31	268	50	13.05	33.44	5.65	25.19	280
75	11.47	33.77	1.77	25.75	227	75	10.70	33.45	4.50	25.64	237
100	9.85	33.86	1.34	26.10	194	100	9.25	33.74	3.40	26.11	193
150	9.41	33.92	1.49	26.22	183	150	8.43	33.96	2.45	26.41	165
200	8.85	34.03	1.30	26.40	167	200	8.00	34.04	2.12	26.54	154
250	8.19	34.11	0.97	26.56	152	250	7.25	34.12	26.71	137
300	7.52	34.14	0.97	26.68	141						
400	6.74	34.22	0.49	26.86	126						
500	6.09	34.26	0.37	26.97	116						
Station 3. February 15, 1938; 1800. Lat. 34°47'N, long. 121°24'W. Wind: WNW 3-4. Sea: heavy						Station 6. February 16, 1938; 1530. Lat. 34°11'N, long. 122°25'W. Wind: NW 1-2. Sea: light					
0	13.22	33.54	5.88	25.23	274	0	13.61	33.41	5.02	25.05	291
10	13.05	33.55	5.65	25.28	271	10	13.14	33.38	5.94	25.13	285
25	12.65	33.54	5.40	25.35	264	25	13.10	33.41	5.72	25.16	282
50	10.50	33.56	4.20	25.76	225	50	13.08	33.43	5.60	25.18	281
75	9.83	33.68	3.77	25.97	206	75	11.16	33.43	4.80	25.54	247
100	9.40	33.76	3.40	26.10	194	100	9.60	33.65	3.85	25.98	205
150	8.70	33.99	2.25	26.39	167	150	8.40	33.90	2.70	26.37	169
200	8.44	34.11	1.50	26.52	155	200	7.80	34.04	1.45	26.56	151
250	8.17	34.14	1.35	26.59	150	250	7.45	34.10	0.85	26.66	142
300	7.65	34.19	1.10	26.71	139	300	7.15	34.16	0.66	26.75	134
400	6.82	34.21	0.72	26.84	128	400	6.50	34.26	0.55	26.92	120
500	6.35	34.22	0.66*	26.91	122	500	5.50	34.28	0.47	27.06	106

*Extrapolated.

Depth (m.) (dbars)	Tempera- ture (°C.)	Salin- ity (°/oo)	Oxy- gen (ml/L.)	σ_t	$10^6\delta$	ΔD (dyn. m.)	Depth (m.) (dbars)	Tempera- ture (°C.)	Salin- ity (°/oo)	Oxy- gen (ml/L.)	σ_t	$10^6\delta$	ΔD (dyn. m.)
Station 7. February 16, 1938; 2300. Lat. 33°49'N, long. 122°51'W. Wind: -. Sea: smooth							Station 10. February 18, 1938; 0200. Lat. 33°36'N, long. 120°58'W. Wind: ESE 3. Sea: moderate						
0	13.97	33.16	5.92	24.79	317		0	14.39	33.49	3.90	24.95	301	
10	13.59	33.17	5.62	24.78	318	.0318	10	14.30	33.45	3.95	24.94	302	.0302
25	13.51	33.15	5.48	24.78	319	.0796	25	14.33	33.46	3.62	24.94	302	.0755
50	13.49	33.17	5.29	24.90	308	.1580	50	14.25	33.48	4.25	24.98	300	.1507
75	12.85	33.21	5.42	25.05	293	.2331	75	11.30	33.39	3.22	25.48	252	.2197
100	11.02	33.32	4.59	25.48	253	.3013	100	10.10	33.60	2.95	25.86	217	.2783
150	8.75	33.74	3.06	26.19	186	.4111	150	8.68	33.82	2.05	26.26	179	.3773
200	7.94	33.94	2.54	26.47	160	.4976	200	8.25	34.03	1.40	26.50	158	.4615
250	7.45	33.98	2.00	26.57	151	.5754	250	7.80	34.09	1.02	26.60	148	.5380
300	6.92	34.04	1.27	26.70	140	.6482	300	7.30	34.14	1.08	26.72	138	.6095
400	5.95	34.08	0.75	26.85	126	.7812	400	6.27	34.19	0.68	26.90	122	.7395
500	5.25	34.16	0.50	27.00	112	.9002	500	5.70	34.22	0.21	26.99	113	.8570
Station 8. February 17, 1938; 1100. Lat. 32°57'N, long. 122°07'W. Wind: -. E 1. Sea: light							Station 15. February 21, 1938; 1830. Lat. 33°34'N, long. 118°26'W. Wind: W 1. Sea: light						
0	14.22	33.25	5.90	24.81	315		0	15.32	33.64	5.89	24.88	309	
10	13.72	33.24	6.02	24.90	306	.0310	10	14.72	33.57	5.92	24.95	302	.0306
25	13.71	33.24	5.78	24.90	306	.0769	25	14.65	33.60	5.83	24.98	299	.0757
50	13.35	33.30	5.58	25.02	296	.1521	50	13.04	33.52	4.95	25.25	274	.1473
75	9.96	33.57	4.02	25.86	216	.2161	75	11.65	33.54	4.40	25.54	247	.2124
100	9.38	33.84	2.70	26.17	188	.2666	100	10.60	33.70	3.45	25.86	218	.2705
150	8.82	33.98	2.17	26.36	170	.3561	150	9.75	33.92	2.45	26.17	188	.3720
200	8.48	34.09	1.71	26.50	157	.4379	200	8.77	34.10	1.88	26.46	161	.4592
250	8.30	34.16	1.42	26.59	150	.5147	250	8.30	34.18	1.40	26.60	149	.5367
300	7.87	34.20	1.05	26.68	142	.5877	300	7.78	34.21	1.09	26.70	140	.6089
400	7.07	34.20	0.90	26.80	132	.7247	400	6.98	34.28	0.66	26.87	124	.7409
500	6.14	34.26	0.54	26.97	116	.8487	500	6.18	34.33	0.39	27.02	111	.8584
Station 9. February 17, 1938; 1830. Lat. 33°19'N, long. 121°30'W. Wind: E 1. Sea: light							Station 16. February 21, 1938; 2230. Lat. 33°24'N, long. 118°43'W. Wind: 0. Sea: smooth						
0	14.21	33.29	6.00	24.84	312		0	15.47	33.57	5.91	24.78	317	
10	13.50	33.26	5.93	24.96	300	.0306	10	14.86	33.65	5.73	24.98	299	.0308
25	13.47	33.28	5.78	24.98	299	.0755	25	14.79	33.63	5.71	24.98	300	.0757
50	13.66	33.35	5.62	25.00	298	.1501	50	12.64	33.57	4.67	25.37	262	.1459
75	12.50	33.37	5.27	25.24	275	.2217	75	11.55	33.58	4.37	25.59	242	.2089
100	10.42	33.42	4.53	25.66	236	.2856	100	10.11	33.77	3.19	25.99	204	.2647
150	8.92	33.77	3.41	26.18	186	.3911	150	9.14	33.93	2.50	26.27	178	.3602
200	7.92	33.96	2.78	26.49	158	.4771	200	8.75	34.09	1.65	26.46	161	.4450
250	7.16	33.97	2.51	26.60	148	.5536	250	8.38	34.21	1.49	26.61	148	.5222
300	6.56	34.02	1.83	26.72	137	.6248	300	7.66	34.21	1.04	26.72	138	.5937
400	5.86	34.14	0.87	26.91	120	.7533	400	7.00	34.26	0.62	26.85	126	.7257
500	5.72	34.29	0.40	27.05	108	.8673	500	6.35	34.30	0.47	26.97	116	.8467
Station 9A. February 17, 1938; 2230. Lat. 33°26'N, long. 121°10'W. Wind: S 1. Sea: smooth							Station 17. February 22, 1938; 0200. Lat. 33°15'N, long. 118°54'W. Wind: W 1. Sea: moderate						
0	13.97	33.50	5.65	25.05	292		0	13.67	33.58	5.87	25.17	280	
10	13.91	33.46	5.75	25.03	294	.0293	10	13.64	33.57	5.85	25.17	280	.0280
25	13.80	33.46	5.80	25.05	292	.0733	25	13.56	33.56	5.84	25.18	280	.0700
50	13.81	33.48	5.76	25.07	291	.1462	50	10.90	33.60	3.82	25.72	229	.1336
75	10.93	33.40	4.65	25.56	245	.2132	75	10.27	33.70	3.42	25.91	212	.1887
100	10.29	33.56	4.07	25.80	223	.2717	100	9.40	33.88	2.91	26.19	185	.2383
150	8.61	33.87	3.07	26.31	175	.3712	150	8.62	34.04	1.98	26.44	162	.3251
200	7.80	34.04	2.43	26.56	151	.4527	200	8.30	34.14	1.28	26.57	151	.4033
							250	7.90	34.19	1.10	26.67	142	.4765
							300	7.55	34.24	0.95	26.76	134	.5455
							400	6.90	34.32	0.60	26.91	120	.6725
							500	6.25	34.35	0.39	27.03	111	.7880

Depth (m.) (dbars)	Tempera- ture (°C.)	Salin- ity (°/oo)	Oxy- gen (ml/L.)	σ_t	$10^6 \delta$	ΔD (dyn. m.)	Depth (m.) (dbars)	Tempera- ture (°C.)	Salin- ity (°/oo)	Oxy- gen (ml/L.)	σ_t	$10^6 \delta$	ΔD (dyn. m.)
Station 18. February 22, 1938; 0630. Lat. 33°06'N, long. 119°08'W. Wind: W 1. Sea: moderate							Station 21. February 22, 1938; 2300. Lat. 32°31'N, long. 120°12'W. Wind: WNW 2. Sea: moderate						
0	13.37	33.58	5.75	25.23	274		0	15.12	33.47	5.84	24.78	317	
10	13.27	33.55	5.62	25.23	275	.0274	10	14.70	33.44	5.66	24.86	311	.0314
25	12.82	33.55	5.39	25.32	267	.0680	25	14.60	33.44	5.64	24.87	310	.0780
50	10.99	33.66	3.93	25.75	226	.1296	50	14.55	33.44	5.70	24.88	309	.1554
75	10.42	33.76	3.50	25.94	210	.1841	75	11.60	33.42	5.35	25.45	255	.2259
100	9.60	33.84	2.88	26.13	191	.2342	100	10.00	33.57	4.40	25.85	217	.2849
150	8.75	34.02	2.18	26.41	165	.3232	150	8.60	33.88	3.25	26.32	174	.3827
200	8.30	34.14	1.51	26.57	151	.4022	200	8.00	33.97	2.60	26.48	159	.4659
250	7.87	34.18	1.19	26.67	140	.4750	250	7.00	34.02	2.80	26.66	142	.5411
300	7.48	34.23	0.95	26.76	134	.5435	300	6.73	34.07	1.70	26.74	135	.6103
400	6.77	34.27	0.46	26.89	122	.6715	400	6.40	34.20	0.75	26.89	123	.7393
500	6.22	34.31	0.36	27.00	114	.7895	500	5.90	34.24	0.46	26.98	115	.8583
Station 18A. February 22, 1938; 1030. Lat. 32° 58'N, long. 119°25'W. Wind: 0. Sea: smooth							Station 22. February 23, 1938; 0203. Lat. 32°21'N, long. 120°26'W. Wind: NW 2. Sea: moderate						
0	13.97	33.57	5.71	25.10	287		0	14.99	33.46	5.76	24.80	315	
10	13.68	33.51	5.33	25.12	286	.0286	10	14.63	33.44	5.79	24.87	310	.0312
25	13.60	33.51	5.32	25.13	284	.0714	25	14.63	33.44	5.72	24.87	310	.0777
50	13.35	33.52	5.18	25.19	280	.1419	50	14.66	33.47	5.51	24.88	309	.1551
75	12.00	33.53	4.70	25.46	254	.2087	75	14.55	33.47	5.60	24.91	307	.2321
100	10.81	33.52	4.43	25.67	235	.2698	100	10.50	33.53	4.25	25.73	229	.2991
150	9.31	33.84	2.91	26.18	187	.3753	150	8.48	33.85	3.75	26.31	174	.3999
200	8.60	34.04	1.70	26.44	163	.4628	200	7.85	34.02	2.48	26.54	153	.4817
250	8.03	34.15	1.15	26.62	147	.5403	250	7.35	34.04	2.25	26.64	145	.5562
300	7.52	34.23	0.88	26.76	134	.6105	300	6.58	34.03	2.15	26.73	136	.6264
400	6.80	34.27	0.50	26.89	123	.7390	400	6.30	34.20	0.63	26.90	121	.7549
500	6.25	34.32	0.33	27.00	113	.8570	500	5.77	34.27	0.38	27.02	111	.8709
Station 19. February 22, 1938; 1430. Lat. 32°48'N, long. 119°46'W. Wind: W 2. Sea: moderate							Station 23. February 23, 1938; 0900. Lat. 32°03'N, long. 120°54'W. Wind: WNW 1. Sea: moderate						
0	15.22	33.51	5.95	24.79	316		0	15.12	33.53	5.34	24.83	313	
10	14.59	33.49	5.82	24.91	305	.0310	10	14.77	33.53	4.90	24.90	306	.0310
25	14.55	33.48	5.65	24.91	306	.0768	25	14.78	33.51	4.79	24.89	308	.0770
50	13.90	33.46	5.66	25.03	295	.1519	50	14.76	33.54	4.78	24.91	306	.1538
75	12.10	33.44	5.15	25.38	262	.2215	75	14.65	33.55	4.40	24.95	304	.2300
100	10.50	33.49	4.45	25.70	232	.2833	100	10.35	33.55	3.75	25.78	225	.2961
150	9.03	33.74	3.60	26.14	190	.3888	150	8.70	33.85	3.05	26.28	177	.3966
200	8.55	33.96	2.80	26.39	168	.4783	200	7.75	33.98	2.60	26.52	155	.4796
250	7.50	34.02	2.10	26.59	149	.5575	250	7.05	34.03	2.35	26.66	142	.5538
300	7.15	34.06	1.65	26.67	142	.6303	300	6.60	34.02	1.95	26.72	137	.6236
400	6.45	34.20	0.70	26.88	123	.7628	400	5.73	34.12	1.02	26.91	120	.7521
							500	5.25	34.17	0.55	27.01	112	.8681
Station 20. February 22, 1938; 1830. Lat. 32°40'N, long. 119°59'W. Wind: W 2-3. Sea: heavy							Station 24. February 23, 1938; 1830. Lat. 31°17'N, long. 120°10'W. Wind: WNW 2. Sea: moderate						
0	15.22	33.44	5.81	24.74	321		0	16.47	33.55	5.68	24.54	340	
10	14.82	33.49	5.76	24.86	310	.0316	10	16.09	33.57	5.04	24.64	331	.0336
25	14.61	33.45	5.62	24.88	309	.0780	25	16.03	33.59	5.43	24.67	328	.0830
50	14.70	33.48	5.55	24.88	309	.1552	50	15.90	33.54	5.31	24.66	330	.1652
75	12.50	33.38	5.58	25.24	275	.2282	75	15.90	33.54	4.87	24.66	331	.2478
100	11.00	33.48	4.45	25.61	241	.2927	100	13.66	33.53	5.51	25.14	286	.3249
150	8.95	33.80	3.48	26.20	185	.3992	150	10.70	33.56	4.48	25.72	231	.4541
200	8.05	33.93	3.15	26.44	162	.4860	200	8.69	33.86	3.15	26.30	177	.5561
250	7.30	33.99	2.60	26.60	148	.5635	250	7.77	33.93	3.00	26.48	159	.6401
300	6.95	34.22	1.55	26.83	127	.6323	300	7.25	34.03	1.85	26.64	145	.7161
400	6.20	34.15	0.80	26.87	124	.7578	400	6.56	34.16	0.75	26.83	128	.8526
500	5.75	34.22	0.53	26.98	114	.8768	500	5.87	34.23	0.50	26.98	115	.9741

Depth (m.) (dbars)	Tempera- ture (°C.)	Salin- ity (‰)	Oxy- gen (ml/L.)	σ_t	10^6	ΔD (dyn. m.)	Depth (m.) (dbars)	Tempera- ture (°C.)	Salin- ity (‰)	Oxy- gen (ml/L.)	σ_t	10^6	ΔD (dyn. m.)
Station 25. February 24, 1938; 0030. Lat. 31°36'N, long. 119°44'W. Wind: NW 1. Sea: moderate							Station 28A. February 24, 1938; 2000. Lat. 32° 19'N, long. 118°16'W. Wind: 0. Sea: smooth						
0	15.62	33.48	5.88	24.68	327		0	15.42	33.63	5.58	24.84	312	
10	15.48	33.44	5.59	24.68	327	.0327	10	14.99	33.64	5.73	24.94	302	.0307
25	15.40	33.42	5.46	24.68	327	.0817	25	14.93	33.65	5.78	24.96	301	.0759
50	15.39	33.41	5.43	24.68	328	.1636	50	13.34	33.65	5.11	25.29	270	.1473
75	15.37	33.44	5.23	24.71	326	.2454	75	10.92	33.55	4.20	25.68	234	.2103
100	13.71	33.41	4.87	25.03	296	.3232	100	9.84	33.61	3.97	25.91	212	.2661
150	10.58	33.48	4.42	25.68	235	.4560	150	9.12	33.94	2.22	26.28	177	.3633
200	9.14	33.92	2.47	26.27	180	.5598	200	8.92	34.15	1.66	26.48	159	.4473
250	8.37	34.09	1.93	26.52	156	.6438	250	8.26	34.19	1.36	26.61	147	.5238
300	7.95	34.17	1.30	26.65	145	.7190	300	7.91	34.20	1.06	26.68	142	.5960
400	6.90	34.23	0.80	26.84	127	.8550	400	7.02	34.26	0.70	26.85	126	.7300
500	6.00	34.28	0.42	27.00	113	.9750	500	6.21	34.30	0.39	26.99	114	.8500
Station 27. February 24, 1938; 0630. Lat. 31°57'N, long. 119°19'W. Wind: W 0-1. Sea: light							Station 29. February 25, 1938; 0030. Lat. 32°30'N, long. 117°59'W. Wind: 0. Sea: smooth						
0	15.62	33.45	5.49	24.66	329		0	15.42	33.59	5.83	24.81	315	
10	15.45	33.43	5.31	24.68	327	.0328	10	15.10	33.58	5.38	24.87	309	.0312
25	15.41	33.42	5.10	24.68	328	.0819	25	14.98	33.58	5.29	24.90	307	.0774
50	15.37	33.39	4.80	24.67	330	.1641	50	14.43	33.49	5.67	24.95	303	.1536
75	13.89	33.39	5.02	24.98	300	.2429	75	11.48	33.50	3.64	25.54	247	.2224
100	12.29	33.38	4.93	25.29	271	.3143	100	10.74	33.59	3.56	25.74	228	.2818
150	9.23	33.70	3.46	26.08	197	.4313	150	9.09	33.91	2.22	26.27	179	.3836
200	8.28	33.91	2.64	26.39	167	.5223	200	8.76	34.10	1.86	26.47	161	.4686
250	8.12	34.17	1.34	26.62	147	.6008	250	8.22	34.16	1.18	26.60	149	.5461
300	7.80	34.21	1.20	26.70	140	.6726	300	7.81	34.19	1.07	26.68	142	.6189
400	6.75	34.27	0.55	26.90	122	.8036	400	6.97	34.25	0.58	26.85	126	.7529
500	6.25	34.30	0.32	26.99	114	.9216	500	6.28	34.29	0.33	26.97	116	.8739
Station 27A. February 24, 1938; 1200. Lat. 32° 00'N, long. 118°57'W. Wind: SSW 0-1. Sea: moderate							Station 30. February 25, 1938; 0500. Lat. 32°36'N, long. 117°41'W. Wind: 0. Sea: smooth						
0	15.02	33.53	6.67	24.86	311		0	15.67	33.62	5.09	24.78	318	
10	14.45	33.55	5.44	24.99	298	.0304	10	15.41	33.64	5.50	24.86	311	.0314
25	14.09	33.51	5.74	25.03	294	.0748	25	15.07	33.62	5.58	24.92	306	.0777
50	13.75	33.52	5.55	25.12	287	.1474	50	14.66	33.59	5.82	24.97	300	.1535
75	11.80	33.54	4.90	25.51	250	.2145	75	12.03	33.60	3.91	25.51	250	.2223
100	10.70	33.60	4.38	25.76	227	.2741	100	10.98	33.68	3.16	25.77	226	.2818
150	9.15	33.78	3.15	26.15	189	.3781	150	9.68	34.05	1.88	26.28	178	.3828
200	8.40	33.98	2.20	26.43	164	.4663	200	9.37	34.20	1.29	26.45	162	.4678
250	8.00	34.13	1.45	26.61	148	.5443	250	8.80	34.19	1.31	26.53	155	.5470
300	7.65	34.22	1.00	26.74	137	.6155	300	8.02	34.21	1.15	26.67	143	.6212
400	6.82	34.28	0.50	26.89	122	.7450	400	7.05	34.27	0.58	26.85	126	.7557
500	6.20	34.29	0.35*	26.98	115	.8635	500	6.40	34.31	0.37	26.97	116	.8767
Station 28. February 24, 1938; 1600. Lat. 32°10'N, long. 118°33'W. Wind: SW 1. Sea: moderate							Station 31. February 25, 1938; 0930. Lat. 32°38'N, long. 117°31'W. Wind: ENE 1. Sea: smooth						
0	15.68	33.59	5.62	24.75	320		0	15.57	33.62	5.68	24.80	316	
10	14.95	33.58	5.66	24.90	306	.0313	10	15.19	33.64	5.51	24.90	306	.0311
25	14.62	33.58	5.74	24.97	300	.0767	25	14.95	33.64	5.45	24.95	302	.0767
50	14.52	33.57	5.62	24.99	299	.1516	50	12.98	33.63	4.41	25.35	264	.1475
75	11.26	33.57	4.17	25.64	238	.2187	75	10.94	33.72	3.37	25.81	221	.2081
100	10.13	33.66	3.35	25.90	213	.2751	100	10.17	33.86	2.64	26.05	199	.2606
150	9.12	33.96	2.41	26.30	176	.3723	150	9.56	34.10	1.73	26.34	172	.3534
200	8.46	34.05	2.13	26.47	160	.4563	200	9.40	34.30	1.12	26.52	156	.4354
250	8.01	34.15	1.56	26.62	147	.5331	250	8.96	34.36	0.81	26.64	145	.5106
300	7.78	34.20	1.02	26.69	140	.6049	300	8.47	34.35	0.80	26.71	139	.5816
400	6.92	34.24	0.58	26.85	126	.7382	400	7.23	34.29	0.67	26.84	127	.7146
500	6.06	34.32	0.26	27.02	111	.8567	500	6.45	34.29	0.40	26.95	118	.8371

Cruise II

Depth (m.) (dbars)	Tempera- ture (°C.)	Salin- ity (‰)	Oxy- gen (ml/L.)	σ_t	$10^5 \delta$	ΔD (dyn. m.)	Depth (m.) (dbars)	Tempera- ture (°C.)	Salin- ity (‰)	Oxy- gen (ml/L.)	σ_t	$10^5 \delta$	ΔD (dyn. m.)
Station 1. April 8, 1938; 0600. Lat. 35°35'N, long. 120°56'W. Wind: -. Sea: smooth							Station 5. April 8, 1938; 2100. Lat. 34°27'N, long. 121°54'W. Wind: W 3. Sea: moderate						
0	11.30	33.56	5.16	25.62	238		0	13.98	33.30	5.58	24.89	307	
10	10.77	33.58	5.41	25.73	228	.0233	10	13.70	33.30	5.65	24.95	302	.0304
25	10.50	33.63	4.72	25.81	220	.0569	25	13.27	33.29	5.57	25.03	294	.0751
50	9.70	33.81	4.10	26.09	194	.1087	50	13.20	33.30	5.65	25.05	293	.1485
75	9.43	33.84	3.68	26.16	188	.1565	75	13.10	33.31	5.68	25.08	291	.2215
100	9.10	33.85	3.04	26.22	182	.2027	100	10.00	33.54	3.85	25.83	220	.2854
150	8.40	34.00	2.08	26.44	162	.2887	150	8.56	33.84	2.62	26.29	176	.3844
200	7.92	34.12	1.38	26.61	147	.3659	200	7.96	33.95	2.40	26.47	160	.4684
Station 2. April 8, 1938; 0930. Lat. 34°56'N, long. 121°08'W. Wind: 0-W 2. Sea: light							Station 6. April 9, 1938; 0200. Lat. 34°09'N, long. 122°25'W. Wind: -. Sea: rough						
0	13.02	33.40	6.08	25.17	281		150	8.50	33.92	26.37	169	
10	12.76	33.40	6.25	25.22	276	.0278	200	7.73	34.02	26.56	151	.0800
25	12.35	33.38	6.30	25.28	270	.0688	250	7.25	34.06	26.66	142	.1532
50	10.85	33.53	4.55	25.67	233	.1317	300	6.98	34.09	26.72	137	.2230
75	9.83	33.61	3.82	25.91	211	.1872	400	6.55	34.14	26.82	129	.3560
100	9.40	33.74	3.30	26.08	195	.2380	500	5.67	34.23	0.37	27.00	112	.4765
150	8.45	33.96	2.45	26.41	165	.3280	Station 25. April 10, 1938; 1530. Lat. 31°26'N, long. 119°29'W. Wind: -. Sea: moderate						
200	7.87	34.07	1.80	26.58	149	.4065	0	15.52	33.56	5.60	24.76	319	
250	7.48	34.13	1.32	26.68	140	.4787	10	15.25	33.56	5.48	24.82	314	.0316
300	7.12	34.17	1.07	26.76	133	.5469	25	15.12	33.56	5.60	24.85	311	.0785
400	6.38	34.19	0.77	26.88	123	.6749	50	14.40	33.55	5.68	25.00	298	.1546
500	5.78	34.24	0.50	27.00	113	.7929	75	13.70	33.57	5.43	25.16	283	.2272
Station 3. April 8, 1938; 1230. Lat. 34°46'N, long. 121°23'W. Wind: W 2. Sea: light							Station 27. April 10, 1938; 2200. Lat. 31°40'N, long. 119°00'W. Wind: W 2-3. Sea: moderate						
0	14.16	33.37	6.02	24.91	305		0	14.98	33.47	5.61	24.81	314	
10	13.18	33.38	5.95	25.12	286	.0296	10	14.70	33.47	6.27	24.87	309	.0312
25	12.89	33.40	5.91	25.20	279	.0720	25	14.68	33.46	5.63	24.87	310	.0776
50	12.50	33.42	5.50	25.28	271	.1408	50	13.90	33.46	5.71	25.03	295	.1532
75	11.30	33.47	4.60	25.55	246	.2054	75	13.40	33.46	5.38	25.14	285	.2257
100	9.62	33.68	3.40	26.00	203	.2615	100	12.63	33.47	5.40	25.30	270	.2951
150	8.55	33.91	2.75	26.36	171	.3550	150	9.65	33.67	3.70	25.99	205	.4139
200	8.05	34.01	2.52	26.50	157	.4370	200	8.63	33.86	3.13	26.30	176	.5091
250	7.52	34.08	1.68	26.64	145	.5125	250	7.80	34.04	2.10	26.56	152	.5911
300	6.88	34.12	1.00	26.76	134	.5823	300	7.33	34.13	1.42	26.70	139	.6639
400	6.12	34.17	0.55	26.90	121	.7098	400	6.75	34.24	0.75	26.87	124	.7954
500	5.60	34.24	0.41	27.02	111	.8258	500	6.25	34.32	0.35	27.00	113	.9139
Station 4. April 8, 1938; 1630. Lat. 34°38'N, long. 121°38'W. Wind: -. Sea: light							Station 25. April 10, 1938; 1530. Lat. 31°26'N, long. 119°29'W. Wind: -. Sea: moderate						
0	14.28	33.30	6.05	24.83	313		0	15.52	33.56	5.60	24.76	319	
10	13.54	33.28	4.87	24.97	300	.0306	10	15.25	33.56	5.48	24.82	314	.0316
25	13.16	33.29	4.90	25.05	292	.0750	25	15.12	33.56	5.60	24.85	311	.0785
50	12.60	33.32	5.65	25.19	280	.1465	50	14.40	33.55	5.68	25.00	298	.1546
75	11.95	33.35	4.90	25.33	266	.2147	75	13.70	33.57	5.43	25.16	283	.2272
100	9.80	33.54	3.67	25.86	216	.2749	100	12.75	33.64	4.87	25.40	260	.2951
150	8.70	33.88	2.70	26.30	175	.3727	150	9.35	33.78	3.75	26.12	193	.4083
200	8.18	34.00	1.70	26.48	159	.4562	200	8.40	33.86	3.26	26.34	173	.4998
250	7.70	34.12	1.18	26.64	144	.5320	250	7.78	33.94	2.91	26.49	159	.5828
300	7.23	34.17	1.00	26.75	135	.6018	300	(7.30)	(34.02)	2.35	26.62	147	.6593
400	6.35	34.22	0.55	26.91	120	.7293	400	(6.45)	(34.16)	1.32	26.85	126	.7958
500	5.65	34.26	0.28	27.03	110	.8443	500	5.83	34.24	0.78	26.99	113	.9153

Depth (m.) (dbars)	Tempera- ture (°C.)	Salin- ity (°/oo)	Oxy- gen (ml/L.)	σ_t	$10^5 \delta$	ΔD (dyn. m.)	Depth (m.) (dbars)	Tempera- ture (°C.)	Salin- ity (°/oo)	Oxy- gen (ml/L.)	σ_t	$10^5 \delta$	ΔD (dyn. m.)
Station 27A. April 11, 1938; 0200. Lat. 31°47'N, long. 118°45'W. Wind: -. Sea: rough							Station 29. April 11, 1938; 1500. Lat. 32°11'N, long. 118°00'W. Wind: -. Sea: -						
0	14.41	33.48	6.05	24.94	302		0	15.10	33.56	5.61	24.86	310	
10	13.99	33.47	5.89	25.02	295	.0298	10	14.30	33.53	5.67	25.00	296	.0303
25	14.01	33.48	5.79	25.03	295	.0740	25	13.87	33.54	5.79	25.10	288	.0741
50	13.85	33.47	5.81	25.05	293	.1475	50	12.24	33.52	5.38	25.41	259	.1425
75	13.09	33.47	5.55	25.21	279	.2190	75	10.30	33.64	3.48	25.86	217	.2020
100	12.25	33.54	5.09	25.42	258	.2861	100	9.36	33.74	2.99	26.10	195	.2535
150	10.02	33.62	3.99	25.89	215	.4043	150	8.91	34.01	1.87	26.37	169	.3445
200	8.43	33.87	2.99	26.34	172	.5011	200	8.66	34.19	1.31	26.55	152	.4247
250	7.95	33.97	2.66	26.49	159	.5839	250	8.05	34.25	1.04	26.69	140	.4977
300	7.22	34.06	1.73	26.66	143	.6594	300	7.69	34.28	0.80	26.78	133	.5659
400	6.48	34.16	0.78	26.85	127	.7944	400	6.70	34.28	0.39	26.92	121	.6929
500	5.71	34.21	0.64	26.98	114	.9149	500	6.03	34.33	0.28	27.04	110	.8084
Station 28. April 11, 1938; 0630. Lat. 31°52'N, long. 118°29'W. Wind: -. Sea: -							Station 30. April 11, 1938; 2000. Lat. 32°26'N, long. 117°46'W. Wind: W 1-2. Sea: light						
0	14.62	33.54	5.81	24.94	302		0	15.70	33.64	5.63	24.79	317	
10	14.20	33.53	5.87	25.02	294	.0298	10	15.42	33.56	5.14	24.79	317	.0317
25	13.47	33.46	5.78	25.12	286	.0733	25	13.82	33.56	5.73	25.13	285	.0769
50	13.12	33.46	5.68	25.19	279	.1439	50	10.76	33.56	4.04	25.71	230	.1413
75	12.38	33.46	5.64	25.34	266	.2120	75	10.06	33.82	2.71	26.04	199	.1949
100	11.93	33.54	5.22	25.48	252	.2768	100	9.62	33.88	2.36	26.16	188	.2433
150	9.42	33.71	3.60	26.06	199	.3896	150	9.04	34.05	1.76	26.38	168	.3323
200	8.60	33.97	2.35	26.40	168	.4814	200	9.02	34.20	1.35	26.51	157	.4135
250	8.43	34.16	1.34	26.57	152	.5614	250	8.58	34.27	0.95	26.63	146	.4893
300	7.52	34.16	1.30	26.70	140	.6344	300	7.98	34.27	0.75	26.72	138	.5603
400	6.23	34.17	0.53	26.89	123	.7659	400	6.85	34.31	0.60	26.91	120	.6893
500	5.79	34.24	0.48	27.00	113	.8839	500	6.18	34.34	0.28	27.03	111	.8048
Station 28A. April 11, 1938; 1030. Lat. 31°58'N, long. 118°14'W. Wind: -. Sea: -							Station 31. April 12, 1938; 0000. Lat. 32°37'. 5 N., long. 117°30'W. Wind: 0. Sea: smooth						
0	14.13	33.50	6.22	25.02	295		0	15.80	33.68	5.19	24.79	316	
10	13.75	33.49	6.48	25.09	288	.0292	10	15.09	33.59	5.55	24.88	308	.0312
25	13.48	33.49	6.40	25.14	284	.0721	25	10.65	33.77	2.55	25.90	212	.0702
50	12.40	33.49	5.55	25.36	264	.1406	50	9.82	33.88	2.08	26.12	191	.1206
75	11.00	33.50	4.46	25.62	239	.2035	75	9.59	34.00	1.60	26.26	178	.1667
100	10.23	33.62	4.19	25.85	217	.2605	100	9.51	34.06	1.49	26.31	174	.2107
150	8.67	33.94	3.36	26.36	170	.3573	150	8.98	34.22	1.05	26.53	154	.2927
200	8.32	34.08	1.71	26.52	155	.4385	200	8.73	34.28	0.87	26.61	147	.3679
250	8.20	34.18	1.10	26.62	147	.5140	250	8.65	34.30	0.57	26.64	145	.4409
300	7.65	34.24	0.88	26.75	135	.5845	300	8.23	34.33	0.57	26.74	137	.5114
400	6.92	34.27	0.49	26.87	124	.7140	400	7.31	34.29	0.51	26.83	128	.6439
500	6.00	34.33	0.32	27.04	109	.8305	500	6.33	34.30	0.34	26.98	116	.7659

Cruise III

Depth (m.) (dbars)	Temperature (°C.)	Salinity (‰)	Oxygen (ml/L.)	σ_t	$10^5 \delta$	ΔD (dyn. m.)	Depth (m.) (dbars)	Temperature (°C.)	Salinity (‰)	Oxygen (ml/L.)	σ_t	$10^5 \delta$	ΔD (dyn. m.)
Station 1. June 13, 1938; 1330. Lat. 35°03'N, long. 120°55'W. Wind: WNW 3. Sea: moderate							Station 5. June 14, 1938; 0800. Lat. 34°28'N, long. 121°54'W. Wind: 2. Sea: moderate						
0	12.35	33.79	5.52	25.60	240		0	13.85	33.43	6.28	25.02	295	
10	12.13	33.81	5.46	25.65	234	.0237	10	13.71	33.41	6.13	25.03	294	.0294
25	11.95	33.82	5.36	25.70	231	.0586	25	13.69	33.41	5.88	25.04	294	.0735
50	10.00	33.84	3.30	26.06	196	.1120	50	11.24	33.57	5.86	25.63	237	.1399
75	9.21	33.89	2.50	26.24	181	.1591	75	9.63	33.63	3.58	25.96	207	.1954
100	8.75	33.98	2.16	26.37	168	.2027	100	8.90	33.83	3.14	26.23	181	.2439
150	8.33	34.05	1.83	26.49	157	.2839	150	8.50	34.00	2.00	26.43	163	.3299
Station 2. June 13, 1938; 1830. Lat. 34°55'.5 N, long. 121°08'W. Wind: NW 5. Sea: heavy							Station 6. June 14, 1938; 1330. Lat. 34°07'N, long. 122°25'W. Wind: NW 3. Sea: -						
0	13.30	33.50	5.97	25.19	279		0	15.10	33.16	5.89	24.55	340	
10	13.17	33.59	6.08	25.28	270	.0274	10	14.90	33.13	5.89	24.57	338	.0339
25	13.00	33.58	5.99	25.31	268	.0678	25	14.82	33.12	6.18	24.58	337	.0845
50	10.72	33.58	4.94	25.74	228	.1298	50	13.65	33.13	6.11	24.84	314	.1659
75	10.15	33.67	3.95	25.91	212	.1848	75	11.70	33.21	5.74	25.27	272	.2391
100	8.75	33.99	2.15	26.38	167	.2322	100	10.25	33.51	4.85	25.76	226	.3013
150	8.38	34.07	1.93	26.50	156	.3130	150	8.50	33.83	3.42	26.30	176	.4018
200	8.36	34.11	1.72	26.54	154	.3905	200	7.80	33.93	2.94	26.48	159	.4856
250	8.21	34.15	1.21	26.60	150	.4665	250	7.07	33.97	2.71	26.61	147	.5621
300	7.50	34.19	0.70	26.73	137	.5383	300	6.60	34.00	2.06	26.70	139	.6336
Station 3. June 13, 1938; 2330. Lat. 34°45'.5 N, long. 121°24'W. Wind: 4. Sea: heavy							Station 7. June 14, 1938, 2000. Lat. 33°48'N, long. 122°55'W. Wind: 4. Sea: moderate						
0	13.75	33.39	6.08	25.01	296		0	14.80	33.09	5.89	24.56	338	
10	13.60	33.35	6.05	25.02	296	.0296	10	14.70	33.06	5.95	24.56	339	.0338
25	13.55	33.33	5.86	25.01	297	.0741	25	14.68	33.05	5.95	24.55	340	.0847
50	11.65	33.63	5.00	25.61	240	.1412	50	13.10	33.15	6.10	24.96	302	.1649
75	10.50	33.80	3.64	25.94	208	.1972	75	11.55	33.27	5.50	25.35	265	.2358
100	9.03	33.86	3.15	26.24	181	.2458	100	10.15	33.52	4.09	25.79	224	.2969
150	8.87	34.03	2.24	26.40	166	.3326	150	8.65	33.76	3.88	26.22	183	.3987
200	8.10	34.08	1.52	26.55	152	.4121	200	7.75	33.92	3.28	26.48	159	.4842
250	7.70	34.11	1.38	26.63	145	.4863	250	7.17	33.97	2.22	26.60	148	.5610
300	7.44	34.15	1.11	26.70	139	.5573	300	6.65	34.04	1.79	26.73	136	.6320
400	6.35	34.21	0.65	26.90	121	.6873	400	5.63	34.11	1.14	26.91	120	.7600
500	5.78	34.26	0.30	27.01	112	.8038	500	4.98	34.15	0.60	27.02	110	.8750
Station 4. June 14, 1938; 0330. Lat. 34°36'.5 N, long. 121°39'W. Wind: -. Sea: -													
0	13.90	33.37	6.22	24.96	300								
10	13.84	33.35	6.16	24.96	301	.0301							
25	13.83	33.34	6.11	24.96	302	.0753							
50	12.42	33.58	6.14	25.42	258	.1453							
75	10.68	33.61	4.73	25.77	225	.2057							
100	9.43	33.79	3.42	26.12	192	.2578							
150	8.14	33.92	2.81	26.42	164	.3468							
200	7.85	34.05	2.29	26.56	151	.4256							
250	7.48	34.14	1.23	26.70	140	.4984							
300	7.02	34.17	1.01	26.78	132	.5664							
400	6.62	34.26	0.53	26.90	121	.6929							
500	5.80	34.30	0.40	27.04	109	.8079							

Depth (m.) (dbars)	Tempera- ture (°C.)	Salin- ity (°/oo)	Oxy- gen (ml/L.)	σ_t	$10^6 \delta$	ΔD (dyn. m.)	Depth (m.) (dbars)	Tempera- ture (°C.)	Salin- ity (°/oo)	Oxy- gen (ml/L.)	σ_t	$10^6 \delta$	ΔD (dyn. m.)
Station 8. June 15, 1938; 0600. Lat. 33°08'N, long. 121°58'W. Wind: NW 2. Sea: moderate							Station 11. June 15, 1938; 2100. Lat. 33°48'N, long. 120°42'.5 W. Wind: 1. Sea: moderate						
0	14.60	33.18	5.85	24.68	328		0	14.20	33.32	6.27	24.86	310	
10	14.46	33.09	5.91	24.63	332	.0330	10	13.90	33.29	6.23	24.90	306	.0308
25	14.46	33.12	5.93	24.65	330	.0826	25	13.76	33.33	6.17	24.96	301	.0763
50	12.82	33.09	6.19	24.97	301	.1615	50	11.41	33.34	5.43	25.43	257	.1461
75	12.09	33.12	5.83	25.13	286	.2349	75	9.95	33.59	4.07	25.88	215	.2051
100	10.82	33.49	5.13	25.65	237	.3003	100	9.43	33.70	3.67	26.05	199	.2569
150	10.13	33.85	4.16	26.05	200	.4095	150	8.48	33.87	2.93	26.33	172	.3497
200	8.74	33.93	2.74	26.34	173	.5027	200	7.60	33.95	2.44	26.52	154	.4312
250	7.85	34.04	1.82	26.56	152	.5839	250	7.40	34.07	1.48	26.65	144	.5057
300	7.26	34.15	1.28	26.74	137	.6561	300	7.26	34.17	0.90	26.75	135	.5755
400	6.43	34.18	0.67	26.87	125	.7871	400	6.68	34.26	0.47	26.90	122	.7040
500	5.76	34.23	0.61	26.99	113	.9061	500	5.90	34.30	0.35	27.03	110	.8200
Station 9. June 15, 1938; 1130. Lat. 33°30'N, long. 121°28'W. Wind: 0. Sea: moderate							Station 12. June 16, 1938; 0100. Lat. 33°53'.5 N, long. 120°27'.5 W. Wind: NW 1. Sea: light						
0	14.65	33.51	6.04	24.92	305		0	13.55	33.51	6.07	25.14	283	
10	14.39	33.53	6.47	24.99	298	.0302	10	13.35	33.70	6.20	25.34	265	.0274
25	14.23	33.53	6.25	25.02	296	.0748	25	12.23	33.69	5.40	25.54	245	.0656
50	11.50	33.61	5.30	25.62	239	.1417	50	11.60	33.71	4.70	25.68	233	.1254
75	9.85	33.67	4.90	25.96	207	.1975	75	9.70	33.74	3.56	26.04	199	.1794
100	9.03	33.81	3.09	26.20	184	.2464	100	8.98	33.80	2.72	26.20	184	.2273
150	8.30	33.94	2.40	26.41	165	.3336	150	8.50	34.11	1.78	26.51	155	.3121
200	7.48	34.01	2.21	26.59	149	.4121	200	8.55	34.18	1.30	26.56	152	.3889
250	7.00	34.07	1.65	26.70	138	.4839	250	8.07	34.23	0.92	26.68	141	.4621
300	6.67	34.13	1.11	26.80	130	.5509	300	7.70	34.23	0.80	26.73	137	.5316
400	6.20	34.23	0.50	26.94	118	.6749	400	6.98	34.24	0.59	26.84	128	.6641
500	5.68	34.26	0.40	27.02	110	.7889	500	6.17	34.24	0.37	26.95	118	.7871
Station 9A. June 15, 1938; 1430. Lat. 33°36'N, long. 121°13'W. Wind: NW 1. Sea: moderate							Station 13. June 12, 1938; 2100. Lat. 34°09'N, long. 120°15'W. Wind: NW 4. Sea: moderate						
0	14.70	33.53	6.18	24.92	304		0	13.40	33.82	6.17	25.41	257	
10	14.69	33.48	6.22	25.01	296	.0300	10	13.15	33.81	6.18	25.46	253	.0255
25	13.76	33.55	6.17	25.13	285	.0736	25	12.45	33.79	5.20	25.58	242	.0626
50	11.57	33.63	5.15	25.62	238	.1390	50	9.88	33.86	2.65	26.10	193	.1170
75	9.89	33.68	4.18	25.96	207	.1946	75	9.35	33.96	1.94	26.26	178	.1634
100	9.12	33.73	3.55	26.12	192	.2445	100	9.20	34.02	1.67	26.33	172	.2072
150	8.25	33.89	2.93	26.38	166	.3345	150	9.03	34.09	1.40	26.42	165	.2914
200	7.85	34.03	2.17	26.55	152	.4145	200	8.77	34.19	1.05	26.54	154	.3712
250	7.53	34.10	1.56	26.65	144	.4885	250	8.23	34.19	0.90	26.62	147	.4464
300	7.18	34.15	1.19	26.74	136	.5585	300	7.53	34.17	0.85	26.71	139	.5179
400	6.35	34.18	0.72	26.88	124	.6885							
500	5.40	34.21	0.52	27.02	111	.8060							
Station 10. June 15, 1938; 1800. Lat. 33°42'N, long. 120°57'.5 W. Wind: -. Sea: -							Station 15. June 11, 1938; 0730. Lat. 33°34'N, long. 118°29'W. Wind: 0. Sea: smooth						
0	14.60	33.47	5.80	24.89	307		0	17.45	33.65	5.86	24.39	355	
10	14.20	33.48	6.08	24.99	298	.0302	10	16.96	33.65	6.09	24.50	344	.0350
25	13.50	33.48	6.07	25.13	285	.0739	25	12.68	33.62	5.69	25.40	259	.0802
50	11.47	33.59	5.27	26.61	240	.1395	50	10.19	33.67	3.67	25.90	212	.1391
75	9.63	33.69	3.76	26.01	202	.1947	75	9.35	33.84	2.97	26.17	187	.1890
100	8.91	33.79	2.75	26.20	184	.2429	100	9.06	33.98	2.21	26.32	172	.2339
150	8.50	33.95	2.25	26.39	167	.3307	150	8.69	34.13	1.61	26.50	156	.3159
200	7.75	34.04	1.91	26.57	150	.4099	200	8.57	34.23	1.18	26.60	148	.3919
250	7.08	34.07	1.53	26.69	140	.4824	250	8.22	34.25	0.73	26.67	142	.4644
300	6.48	34.07	1.39	26.77	132	.5504	300	7.77	34.27	0.66	26.75	135	.5336
400	6.07	34.18	0.62	26.91	120	.6764	400	6.98	34.30	0.42	26.89	123	.6626
500	5.62	34.24	0.45	27.02	111	.7919	500	6.18	34.32	0.31	27.01	112	.7801

Depth (m.) (dbars)	Tempera- ture (°C.)	Salin- ity (°/oo)	Oxy- gen (ml/L.)	σ_t	$10^5 \delta$	ΔD (dyn. m.)	Depth (m.) (dbars)	Tempera- ture (°C.)	Salin- ity (°/oo)	Oxy- gen (ml/L.)	σ_t	$10^5 \delta$	ΔD (dyn. m.)
Station 16. June 11, 1938; 0400. Lat. 33°25'N, long. 118°45'W. Wind: W 1. Sea: light							Station 19. June 10, 1938; 1000. Lat. 32°30'N, long. 119°35'.5 W. Wind: NW 1. Sea: moderate						
0	17.48	33.69	5.81	24.42	353		0	14.00	33.14	6.09	24.77	319	
10	17.05	33.67	5.76	24.50	345	.0349	10	13.82	33.12	5.98	24.79	317	.0318
25	12.12	33.61	5.66	25.50	249	.0795	25	13.70	33.13	5.88	24.82	314	.0791
50	10.29	33.71	4.00	25.91	211	.1370	50	12.05	33.19	5.21	25.20	280	.1533
75	9.54	33.95	2.15	26.22	182	.1861	75	11.00	33.52	4.40	25.64	237	.2179
100	9.38	34.05	1.54	26.33	172	.2303	100	9.05	33.74	3.51	26.14	190	.2713
150	9.04	34.20	1.42	26.50	157	.3125	150	8.30	33.93	2.80	26.40	165	.3601
200	8.85	34.26	0.96	26.58	150	.3892	200	7.80	34.03	2.03	26.56	152	.4393
250	8.56	34.30	0.91	26.66	144	.4627	250	7.40	34.06	1.76	26.64	144	.5133
300	7.91	34.31	0.76	26.76	134	.5322	300	7.23	34.15	1.17	26.73	136	.5833
400	6.87	34.29	0.54	26.89	122	.6602	400	6.65	34.30	0.41	26.93	118	.7103
500	6.26	34.30	0.40	26.98	115	.7787	500	6.05	34.33	0.30	27.03	110	.8243
Station 17. June 11, 1938; 0000. Lat. 33°16'N, long. 119°00'W. Wind: 0. Sea: smooth							Station 20. June 10, 1938; 0600. Lat. 32°26'N, long. 119°54'W. Wind: W 2. Sea: moderate						
0	16.70	33.70	6.15	24.60	334		0	14.60	33.20	5.87	24.69	326	
10	16.64	33.68	5.95	24.60	335	.0334	10	14.34	33.15	5.90	24.70	325	.0326
25	13.24	33.58	5.92	25.26	272	.0789	25	14.18	33.27	6.09	24.83	314	.0805
50	10.70	33.64	4.20	25.79	223	.1408	50	13.40	33.37	6.05	25.07	291	.1561
75	9.77	33.93	2.29	26.18	187	.1920	75	11.70	33.40	5.35	25.42	258	.2247
100	9.28	34.01	2.00	26.31	174	.2371	100	9.98	33.59	4.19	25.88	216	.2839
150	8.93	34.21	1.21	26.53	154	.3191	150	8.73	33.85	3.27	26.28	178	.3824
200	8.74	34.26	0.95	26.60	148	.3946	200	7.78	34.00	2.31	26.54	154	.4654
250	8.45	34.31	0.72	26.68	141	.4668	250	7.25	34.11	1.62	26.70	139	.5386
300	7.87	34.30	0.72	26.76	134	.5356	300	7.00	34.22	0.97	26.82	128	.6054
400	6.90	34.31	0.45	26.91	121	.6631	400	6.61	34.29	0.51	26.94	119	.7289
500	6.18	34.33	0.37	27.02	111	.7791	500	5.89	34.30	0.37	27.03	110	.8434
Station 18. June 10, 1938; 2000. Lat. 33°07'N, long. 119°13'W. Wind: NW 1. Sea: light							Station 21. June 10, 1938; 0130. Lat. 32°22'N, long. 120°11'W. Wind: W 2. Sea: light						
0	16.25	33.72	6.09	24.72	323		0	15.95	33.42	5.63	24.56	338	
10	16.19	33.70	6.26	24.72	324	.0324	10	15.56	33.38	5.71	24.62	333	.0336
25	12.83	33.68	5.23	25.42	257	.0760	25	15.50	33.38	5.72	24.64	332	.0835
50	9.94	33.70	3.87	25.96	206	.1339	50	14.20	33.31	5.80	24.86	312	.1640
75	9.33	33.80	3.22	26.14	189	.1833	75	12.95	33.35	5.25	25.14	285	.2386
100	8.79	33.94	2.56	26.34	171	.2283	100	11.16	33.42	4.78	25.53	248	.3052
150	8.78	34.13	1.55	26.49	158	.3105	150	9.37	33.68	3.76	26.04	200	.4172
200	8.60	34.30	0.87	26.65	143	.3857	200	8.48	33.93	2.50	26.38	169	.5094
250	8.03	34.29	0.76	26.73	136	.4555	250	7.65	34.01	2.28	26.56	152	.5896
300	7.71	34.30	0.55	26.78	132	.5225	300	7.62	34.17	1.15	26.69	140	.6626
400	6.71	34.30	0.51	26.93	119	.6480	400	6.97	34.28	0.65	26.87	124	.7946
500	6.08	34.33	0.38	27.04	110	.7625	500	6.20	34.34	0.42	27.02	111	.9121
Station 18A. June 10, 1938; 1600. Lat. 33°00'N, long. 119°26'.5 W. Wind: W 1. Sea: moderate							Station 22. June 9, 1938; 2100. Lat. 32°17'N, long. 120°29'W. Wind: 1-2. Sea: moderate						
0	16.30	33.72	6.01	24.71	324		0	16.20	33.52	5.66	24.58	337	
10	15.91	33.68	6.02	24.77	319	.0322	10	16.18	33.50	5.75	24.57	338	.0338
25	12.60	33.68	5.45	25.47	253	.0751	25	16.16	33.44	5.73	24.53	342	.0848
50	9.75	33.76	3.20	26.04	198	.1315	50	14.77	33.32	5.86	24.74	322	.1678
75	9.03	33.85	3.20	26.23	181	.1789	75	14.30	33.46	5.81	24.96	303	.2459
100	8.85	33.92	2.72	26.31	174	.2233	100	12.55	33.50	5.44	25.33	267	.3171
150	8.65	34.17	1.46	26.54	153	.3051	150	9.40	33.69	4.02	26.04	200	.4339
200	8.40	34.21	0.95	26.61	147	.3801	200	8.20	33.92	3.15	26.41	165	.5251
250	7.85	34.28	0.72	26.75	135	.4506	250	7.53	33.97	2.75	26.55	153	.6046
300	7.10	34.29	0.68	26.86	124	.5154	300	6.98	34.02	2.13	26.67	142	.6784
400	6.53	34.30	0.40	26.95	117	.6359	400	6.25	34.08	1.10	26.81	130	.8144
500	6.00	34.29	0.39	27.01	112	.7504	500	5.50	34.18	0.58	26.98	114	.9364

Depth (m.) (dbars)	Tempera- ture (°C.)	Salin- ity (°/oo)	Oxy- gen (ml/L.)	σ_t	$10^6\delta$	ΔD (dyn. m.)	Depth (m.) (dbars)	Tempera- ture (°C.)	Salin- ity (°/oo)	Oxy- gen (ml/L.)	σ_t	$10^6\delta$	ΔD (dyn. m.)
Station 23. June 9, 1938; 1400. Lat. 31°54'N, long. 120°50'W. Wind: NW 2-3. Sea: heavy							Station 27A. June 8, 1938; 0730. Lat. 31°58'N, long. 118°43'.5 W. Wind: 0. Sea: light						
0	16.56	33.51	5.69	24.49	345		0	16.75	33.58	5.78	24.50	344	
10	16.20	33.48	5.74	24.55	340	.0342	10	16.65	33.57	5.44	24.51	343	.0344
25	16.19	33.45	5.72	24.53	342	.0854	25	13.69	33.58	6.27	25.17	281	.0812
50	15.35	33.43	5.65	24.70	326	.1689	50	11.88	33.64	5.24	25.58	243	.1467
75	14.96	33.55	5.59	24.88	310	.2484	75	10.82	33.66	4.36	25.78	224	.2051
100	14.40	33.64	5.68	25.07	292	.3236	100	9.31	33.78	3.28	26.13	191	.2570
150	11.15	33.69	5.08	25.74	229	.4538	150	8.18	34.04	2.51	26.51	156	.3438
200	9.17	33.76	4.04	26.14	192	.5590	200	7.87	34.13	1.57	26.63	145	.4190
250	8.10	33.92	3.36	26.43	165	.6482	250	7.26	34.16	1.41	26.74	135	.4890
300	7.30	34.00	2.55	26.61	148	.7264	300	6.64	34.15	0.92	26.82	128	.5548
400	6.42	34.12	1.25	26.82	129	.8649	400	6.33	34.24	0.64	26.93	119	.6783
500	5.65	34.17	0.67	26.96	117	.9879	500	5.84	34.30	0.37	27.04	109	.7923
Station 24. June 8, 1938; 2230. Lat. 31°11'N, long. 119°56'W. Wind: 1. Sea: moderate							Station 28. June 8, 1938; 0230. Lat. 32°05'N, long. 118°28'W. Wind: W 2. Sea: light						
0	15.70	33.41	5.85	24.61	334		0	17.23	33.72	5.65	24.49	345	
10	15.54	33.39	5.75	24.63	332	.0333	10	17.01	33.71	5.89	24.54	341	.0343
25	15.54	33.40	5.67	24.64	332	.0831	25	16.32	33.64	5.92	24.64	331	.0847
50	14.57	33.40	5.76	24.85	312	.1636	50	11.06	33.67	3.67	25.74	227	.1545
75	13.70	33.40	5.66	25.03	296	.2396	75	10.17	33.78	2.82	25.99	204	.2084
100	12.00	33.55	5.05	25.48	253	.3082	100	9.35	33.95	2.45	26.26	179	.2563
150	9.53	33.74	3.44	26.06	198	.4210	150	8.60	34.05	2.34	26.45	161	.3413
200	8.35	33.97	1.93	26.43	164	.5115	200	8.71	34.21	1.31	26.56	152	.4195
250	7.98	34.10	1.24	26.59	150	.5900	250	8.02	34.25	1.05	26.70	139	.4923
300	7.76	34.16	1.23	26.67	143	.6632	300	7.66	34.32	0.65	26.81	130	.5595
400	6.22	34.17	0.98	26.89	123	.7965	400	6.71	34.30	0.41	26.93	119	.6840
							500	6.09	34.32	0.39	27.02	111	.7990
Station 25. June 8, 1938; 1630. Lat. 31°30'N, long. 119°26'W. Wind: NW 2. Sea: heavy							Station 28A. June 7, 1938; 2300. Lat. 32°12'N, long. 118°13'W. Wind: 0. Sea: light						
0	15.91	33.53	6.27	24.65	330		0	17.35	33.70	5.64	24.45	349	
10	15.50	33.51	6.17	24.74	322	.0326	10	17.20	33.69	5.84	24.48	347	.0348
25	14.33	33.49	6.16	24.97	300	.0792	25	17.14	33.64	5.98	24.45	349	.0870
50	12.56	33.54	5.50	25.37	263	.1496	50	11.56	33.62	4.07	25.62	239	.1605
75	11.16	33.58	4.85	25.66	236	.2120	75	10.35	33.69	3.38	25.89	214	.2171
100	10.50	33.64	3.94	25.82	220	.2690	100	9.53	33.86	2.71	26.16	188	.2673
150	8.10	33.94	2.93	26.44	162	.3645	150	8.36	34.00	2.39	26.46	161	.3545
200	7.43	34.02	2.58	26.60	147	.4417	200	8.18	34.14	1.72	26.59	149	.4320
250	6.92	34.04	2.03	26.70	139	.5132	250	7.60	34.17	1.46	26.70	139	.5040
300	6.51	34.05	1.52	26.75	134	.5814	300	7.52	34.23	0.94	26.76	134	.5722
400	5.80	34.14	0.73	26.92	120	.7084	400	6.96	34.31	0.43	26.90	122	.7002
500	5.35	34.28	0.36	27.08	104	.8204	500	6.16	34.33	0.30	27.02	111	.8167
Station 27. June 8, 1938; 1130. Lat. 31°48'N, long. 118°58'W. Wind: NW 1. Sea: moderate							Station 29. June 7, 1938; 1830. Lat. 32°19'N, long. 117°59'W. Wind: WSW 0-2. Sea: light						
0	16.50	33.65	5.74	24.62	334		0	17.72	33.62	5.47	24.30	363	
10	16.34	33.58	5.95	24.59	336	.0335	10	17.25	33.57	5.80	24.37	356	.0310
25	13.25	33.47	6.32	25.17	281	.0798	25	14.65	33.48	6.30	24.89	308	.0808
50	12.12	33.57	5.60	25.47	253	.1466	50	11.07	33.58	4.94	25.67	234	.1486
75	10.68	33.61	4.40	25.77	225	.2064	75	10.09	33.69	3.16	25.94	210	.2041
100	9.48	33.71	3.67	26.05	199	.2594	100	9.57	33.93	2.35	26.20	184	.2533
150	8.37	33.92	3.42	26.39	167	.3509	150	9.17	34.10	1.65	26.40	166	.3408
200	8.10	34.14	1.46	26.60	148	.4297	200	9.25	34.24	1.07	26.50	158	.4218
250	7.63	34.16	1.33	26.69	140	.5017	250	9.00	34.29	0.80	26.58	151	.4990
300	7.15	34.22	0.74	26.80	130	.5692	300	8.46	34.30	0.76	26.67	143	.5725
400	6.24	34.27	0.33	26.96	115	.6917	400	7.45	34.31	0.46	26.83	129	.7085
500	5.85	34.30	0.33	27.04	109	.8037	500	6.56	34.32	0.30	26.96	117	.8315

Depth (m.) (dbars)	Tempera- ture (°C.)	Salin- ity (°/oo)	Oxy- gen (ml/L.)	σ_t	$10^5 \delta$	ΔD (dyn. m.)	Depth (m.) (dbars)	Tempera- ture (°C.)	Salin- ity (°/oo)	Oxy- gen (ml/L.)	σ_t	$10^5 \delta$	ΔD (dyn. m.)
Station 30. June 7, 1938; 1330. Lat. 32°29'N, long. 117°43' W. Wind: 0. Sea: smooth							Station 31. June 7, 1938; 0830. Lat. 32°36'.5 N, long. 117°30'.5 W. Wind: 0. Sea: smooth						
0	18.39	33.75	5.65	24.24	369		0	17.95	33.61	5.79	24.24	369	
10	17.91	33.69	5.66	24.31	363	.0366	10	17.62	33.62	6.00	24.32	361	.0365
25	15.44	33.61	6.21	24.82	314	.0874	25	13.28	33.50	6.10	25.19	279	.0845
50	11.36	33.58	4.67	25.62	239	.1565	50	10.84	33.59	4.36	25.72	229	.1480
75	9.92	33.78	3.01	26.03	200	.2114	75	9.78	33.76	3.65	26.04	199	.2015
100	9.37	33.93	2.36	26.24	181	.2590	100	9.47	33.85	2.82	26.16	188	.2499
150	9.16	34.12	1.80	26.42	164	.3452	150	8.81	34.04	2.18	26.41	165	.3381
200	9.04	34.23	1.18	26.53	155	.4250	200	8.53	34.17	1.52	26.56	152	.4173
250	8.63	34.23	1.09	26.59	150	.5012	250	8.24	34.22	1.20	26.64	145	.4915
300	8.32	34.28	0.85	26.68	142	.5742	300	7.89	34.28	0.95	26.74	136	.5617
400	7.50	34.33	0.56	26.84	128	.7092	400	7.10	34.31	0.51	26.88	124	.6917
500	6.36	34.30	0.45	26.97	116	.8312	500	6.02	34.32	0.34	27.03	110	.8087

Cruise IV

Depth (m.) (dbars)	Tempera- ture (°C.)	Salin- ity (‰)	Oxy- gen (ml/L.)	σ_t	10^6	ΔD (dyn. m.)	Depth (m.) (dbars)	Tempera- ture (°C.)	Salin- ity (‰)	Oxy- gen (ml/L.)	σ_t	10^6	ΔD (dyn. m.)
Station 1. August 17, 1938; 0700. Lat. $35^{\circ}02'.5$ N, long. $120^{\circ}56'.5$ W. Wind: 0. Sea: light							Station 5, August 18, 1938; 0100. Lat. $34^{\circ}28'$ N, long. $121^{\circ}54'$ W. Wind: W 1. Sea: light						
0	14.75	33.36	6.38	24.78	318		0	17.30	33.23	5.80	24.10	382	
10	14.01	33.34	6.28	24.92	305	.0312	10	16.99	33.22	5.90	24.17	376	.0379
25	11.66	33.32	4.18	25.36	262	.0737	25	16.05	33.12	6.03	24.31	363	.0933
50	11.10	33.59	4.40	25.68	233	.1356	50	12.67	33.01	6.23	24.93	304	.1767
75	10.42	33.72	3.44	25.90	213	.1914	75	11.64	33.08	6.10	25.18	281	.2498
100	9.97	33.84	3.09	26.07	197	.2426	100	10.96	33.30	5.30	25.48	253	.3166
150	9.21	33.98	1.56	26.30	176	.3358	150	9.10	33.76	3.65	26.15	190	.4274
200	8.83	34.14	1.28	26.49	159	.4196	200	7.92	33.94	3.25	26.47	160	.5149
250	8.22	34.16	1.30	26.60	149	.4966	250	7.41	34.01	2.54	26.60	148	.5919
							300	6.91	34.05	1.82	26.70	139	.6637
							400	5.81	34.11	1.34	26.90	122	.7942
							500	5.12	34.16	0.77	27.01	111	.9107
Station 2. August 17, 1938; 1130. Lat. $34^{\circ}56'.5$ N, long. $121^{\circ}07'.5$ W. Wind: 0. Sea: light							Station 6. August 18, 1938; 0700. Lat. $34^{\circ}09'.5$ N, long. $122^{\circ}15'$ W. Wind: 0. Sea: light						
0	15.60	33.31	6.60	24.55	339		0	17.05	33.13	6.15	24.08	384	
10	14.62	33.31	6.60	24.77	319	.0329	10	16.42	33.05	5.93	24.17	376	.0380
25	14.42	33.44	6.10	24.92	306	.0798	25	16.67	33.14	5.90	24.18	375	.0943
50	13.18	33.58	5.15	25.27	272	.1520	50	13.65	33.12	6.47	24.82	315	.1805
75	11.95	33.60	4.27	25.53	248	.2170	75	11.50	33.14	6.00	25.25	274	.2541
100	10.22	33.69	3.39	25.91	212	.2745	100	10.73	33.29	5.35	25.51	250	.3196
150	9.45	33.94	2.15	26.23	182	.3730	150	8.97	33.77	3.65	26.18	187	.4288
200	9.03	34.05	1.90	26.38	168	.4605	200	8.13	33.89	3.02	26.40	166	.5170
250	8.70	34.14	1.45	26.51	158	.5420	250	7.38	34.00	2.70	26.59	149	.5958
300	8.05	34.15	1.20	26.61	148	.6185	300	6.92	34.01	2.02	26.67	142	.6686
400	7.23	34.21	0.74	26.78	133	.7590	400	6.02	34.06	1.00	26.82	128	.8036
500	6.38	34.24	0.42	26.92	121	.8860	500	5.48	34.17	0.47	26.98	115	.9251
Station 3. August 17, 1938; 1530. Lat. $34^{\circ}46'$ N, long. $121^{\circ}23'$ W. Wind: W 1. Sea: moderate							Station 7. August 18, 1938; 1300. Lat. $33^{\circ}50'$ N, long. $122^{\circ}55'$ W. Wind: 0. Sea: light						
0	18.36	33.32	5.99	23.91	400		0	17.30	33.27	6.00	24.13	379	
10	16.97	33.25	6.02	24.20	374	.0387	10	16.48	33.22	5.92	24.29	365	.0372
25	16.43	33.38	6.12	24.42	352	.0931	25	15.29	33.17	6.23	24.52	343	.0903
50	11.60	33.20	5.99	25.28	271	.1710	50	11.65	33.05	6.05	25.16	282	.1684
75	10.57	33.36	6.83	25.59	242	.2351	75	10.80	33.23	5.54	25.45	255	.2355
100	10.09	33.60	4.38	25.86	217	.2925	100	9.78	33.51	4.35	25.84	218	.2946
150	8.58	33.84	3.59	26.29	176	.3907	150	8.62	33.91	2.70	26.34	172	.3921
200	7.63	33.96	3.08	26.53	154	.4732	200	7.81	33.99	2.40	26.52	155	.4739
250	6.82	34.01	2.12	26.68	140	.5467	250	7.32	34.04	2.08	26.63	145	.5489
300	6.20	34.07	1.34	26.81	128	.6137	300	6.68	34.00	1.90	26.69	140	.6201
400	5.90	34.17	0.77	26.93	118	.7367	400	5.68	34.14	0.92	26.93	118	.7491
500	5.86	34.22	0.40	26.97	116	.8527	500	5.21	34.21	0.46	27.04	108	.8620
Station 4. August 17, 1938; 2030. Lat. $34^{\circ}37'$ N, long. $121^{\circ}39'$ W. Wind: 0. Sea: light							Station 8. August 18, 1938; 2200. Lat. $33^{\circ}00'$ N, long. $121^{\circ}58'$ W. Wind: 0. Sea: moderate						
0	17.20	33.29	6.02	24.17	375		0	17.30	33.18	5.50	24.06	386	
10	16.42	33.21	6.00	24.29	364	.0370	10	16.74	33.16	5.67	24.18	375	.0380
25	16.38	33.31	6.07	24.38	356	.0910	25	16.15	33.22	5.88	24.36	358	.0930
50	12.41	33.05	6.25	25.01	296	.1725	50	12.45	33.12	6.00	25.06	292	.1742
75	11.17	33.18	5.73	25.34	265	.2426	75	11.20	33.75	3.95	25.78	224	.2387
100	9.76	33.40	4.68	25.76	226	.3040	100	9.50	33.85	3.20	26.15	189	.2903
150	8.40	33.86	3.29	26.33	172	.4035	150	8.29	33.93	2.90	26.41	165	.3788
200	7.78	33.95	2.60	26.50	157	.4857	200	8.39	34.11	1.30	26.53	154	.4586
250	7.19	33.95	2.57	26.58	150	.5625	250	8.13	34.17	1.25	26.62	147	.5338
300	6.95	34.02	1.72	26.67	142	.6355	300	7.52	34.15	1.35	26.69	140	.6056
400	5.95	34.08	0.95	26.85	126	.7695	400	6.17	34.13	0.98	26.86	125	.7381
500	5.12	34.12	0.62	26.98	114	.8895	500	5.97	34.25	0.58	26.98	115	.8581

Depth (m.) (dbars)	Tempera- ture (°C.)	Salin- ity (‰)	Oxy- gen (ml/L.)	σ_t	10^5	ΔD (dyn. m.)	Depth (m.) (dbars)	Tempera- ture (°C.)	Salin- ity (‰)	Oxy- gen (ml/L.)	σ_t	10^5	ΔD (dyn. m.)
Station 9. August 19, 1938; 0330. Lat. 33°26'N, long. 121°43'.5 W. Wind: W l. Sea: light							Station 11. August 19, 1938; 2000. Lat. 33°45'N, long. 120°42'.5 W. Wind: NW 3. Sea: moderate						
0	17.45	33.74	5.57	24.46	348		0	17.80	33.68	5.78	24.33	361	
10	17.27	33.70	5.85	24.47	348	.0348	10	17.25	33.68	5.86	24.46	348	.0354
25	15.13	33.60	5.61	24.88	309	.0841	25	16.40	33.68	5.82	24.66	330	.0862
50	11.80	33.58	4.50	25.54	246	.1535	50	12.50	33.55	5.28	25.38	261	.1601
75	10.13	33.80	3.01	26.01	202	.2095	75	9.92	33.55	4.10	25.86	217	.2199
100	9.42	33.93	2.55	26.23	182	.2575	100	9.00	33.73	3.55	26.14	190	.2708
150	8.90	34.15	1.58	26.48	158	.3425	150	8.13	33.95	3.00	26.45	161	.3586
200	8.56	34.24	1.17	26.61	147	.4187	200	7.75	33.98	2.88	26.53	154	.4374
250	8.25	34.26	1.07	26.68	142	.4909	250	7.23	34.02	2.37	26.63	145	.5122
300	7.78	34.27	0.90	26.75	135	.5601	300	6.98	34.05	1.74	26.70	140	.5834
400	6.97	34.29	0.59	26.88	124	.6896	400	6.67	34.12	0.90	26.79	132	.7194
500	6.36	34.33	0.58	26.99	114	.8086	500	5.98	34.22	0.53	26.96	117	.8439
Station 9A. August 19, 1938; 0700. Lat. 33°35'N, long. 121°29'W. Wind: 0. Sea: light							Station 12. August 20, 1938; 0030. Lat. 33°52'.5 N, long. 120°28'W. Wind: NW 3-4. Sea: moderate						
0	17.05	33.20	5.60	24.14	379		0	18.20	33.66	5.66	24.21	372	
10	16.85	33.20	5.62	24.18	374	.0376	10	18.00	33.68	5.60	24.28	366	.0369
25	16.69	33.26	5.62	24.27	367	.0932	25	16.00	33.67	5.35	24.74	322	.0885
50	12.48	33.16	5.80	25.09	289	.1752	50	11.05	33.65	4.05	25.73	228	.1573
75	10.70	33.45	4.61	25.64	237	.2410	75	9.88	33.75	3.20	26.01	202	.2111
100	9.49	33.83	2.45	26.14	190	.2944	100	9.38	33.89	2.40	26.20	184	.2593
150	8.86	34.16	1.44	26.50	157	.3812	150	8.99	34.07	1.52	26.41	165	.3465
200	8.55	34.21	1.10	26.59	149	.4577	200	8.86	34.13	1.10	26.47	160	.4277
250	8.40	34.22	1.10	26.62	147	.5317	250	8.54	34.20	0.90	26.58	151	.5055
300	8.22	34.27	0.77	26.68	142	.6039	300	8.18	34.21	0.80	26.64	145	.5795
400	7.72	34.28	0.64	26.77	135	.7424	400	7.15	34.22	0.74	26.80	131	.7175
500	6.95	34.26	0.45	26.86	127	.8734	500	6.20	34.22	0.55	26.93	120	.8430
Station 10. August 19, 1938; 1200. Lat. 33°43'.5 N, long. 121°15'.5 W. Wind: NW 2. Sea: light							Station 13. August 16, 1938; 1830. Lat. 34°07'.5 N, long. 120°00'W. Wind: W 2. Sea: moderate						
0	17.60	33.13	5.32	23.95	396		0	16.60	33.71	6.43	24.63	332	
10	16.99	33.10	5.44	24.08	385	.0390	10	16.00	33.64	6.40	24.72	324	.0328
25	16.35	33.11	5.75	24.24	371	.0957	25	13.15	33.67	5.50	25.35	264	.0769
50	13.23	33.30	5.82	25.05	293	.1787	50	11.20	33.69	3.90	25.74	228	.1384
75	11.94	33.40	5.35	25.37	263	.2482	75	9.98	33.78	2.75	26.02	201	.1920
100	10.74	33.71	4.07	25.83	219	.3084	100	9.46	33.89	2.32	26.20	185	.2402
150	9.19	34.03	1.85	26.34	172	.4062	150	9.14	34.04	1.70	26.36	170	.3290
200	8.80	34.15	1.45	26.50	158	.4887	200	8.85	34.15	1.08	26.49	158	.4110
250	8.54	34.20	1.07	26.58	151	.5659	250	8.48	34.18	0.78	26.57	151	.4882
300	8.20	34.30	0.90	26.72	139	.6384	300	7.93	34.23	0.70	26.70	140	.5610
400	7.36	34.27	0.66	26.82	131	.7734	400	7.10	34.21	0.50	26.80	131	.6965
500	6.54	34.31	0.45	26.95	118	.8979							
Station 10A. August 19, 1938; 1600. Lat. 33°44'.5 N, long. 121°00'W. Wind: W l. Sea: moderate							Station 15. August 22, 1938; 1500. Lat. 33°33' .5 N, long. 118°28'W. Wind: W 2-3. Sea: moderate						
0	18.10	33.18	5.53	23.87	404		0	21.10	33.69	5.40	23.49	441	
10	17.13	33.18	5.57	24.10	382	.0393	10	20.50	33.69	5.42	23.65	426	.0434
25	16.87	33.20	5.56	24.18	375	.0961	25	13.20	33.54	5.60	25.24	274	.0959
50	13.53	33.21	6.02	24.92	306	.1812	50	10.91	33.57	4.20	25.69	232	.1591
75	12.50	33.31	5.62	25.20	279	.2543	75	10.13	33.70	3.33	25.93	209	.2142
100	10.85	33.43	4.80	25.60	242	.3194	100	9.70	33.86	2.55	26.13	191	.2642
150	8.82	33.81	3.58	26.23	182	.4254	150	9.10	34.03	1.95	26.36	170	.3544
200	7.88	33.98	2.85	26.51	156	.5099	200	9.01	34.11	1.55	26.43	164	.4379
250	7.38	34.01	2.34	26.60	148	.5859	250	8.86	34.16	1.32	26.50	158	.5184
300	6.92	34.03	1.95	26.68	141	.6581	300	8.86	34.21	1.13	26.54	156	.5969
400	6.20	34.12	1.12	26.85	126	.7916	400	8.09	34.28	0.80	26.71	141	.7454
500	5.56	34.20	0.58	26.99	113	.9111	500	6.82	34.28	0.55	26.89	124	.8779

Depth (m.) (dbars)	Tempera- ture (°C.)	Salin- ity (°/oo)	Oxy- gen (ml/L.)	σ_t	$10^5 \delta$	ΔD (dyn. m.)	Depth (m.) (dbars)	Tempera- ture (°C.)	Salin- ity (°/oo)	Oxy- gen (ml/L.)	σ_t	$10^5 \delta$	ΔD (dyn. m.)
Station 16. August 22, 1938; 2100. Lat. 33°25'N, long. 118°43'.5 W. Wind: WSW 2. Sea: moderate							Station 19. August 23, 1938. Lat. 32°47'.5 N., long. 119°43'.5 W. Wind: WNW 3. Sea: moderate						
0	20.25	33.73	5.70	23.75	416		0	17.20	33.64	5.64	24.44	350	
10	19.80	33.70	5.60	23.84	408	.0412	10	17.10	33.52	5.85	24.37	357	.0354
25	15.00	33.50	6.40	24.83	313	.0953	25	16.80	33.53	5.60	24.45	350	.0884
50	11.25	33.60	5.28	25.66	235	.1638	50	13.30	33.28	5.70	25.02	296	.1692
75	9.88	33.71	3.81	25.98	205	.2078	75	12.16	33.53	5.05	25.43	257	.2383
100	9.38	33.78	2.90	26.12	192	.2574	100	10.90	33.62	4.25	25.74	229	.2991
150	9.10	34.09	1.79	26.41	166	.3469	150	8.88	33.81	3.44	26.22	183	.4021
200	9.06	34.16	1.50	26.47	161	.4287	200	8.08	33.96	2.86	26.46	161	.4881
250	9.07	34.26	0.75	26.54	154	.5075	250	7.58	34.05	2.01	26.61	148	.5653
300	8.80	34.24	1.18	26.57	152	.5840	300	7.43	34.17	1.26	26.72	138	.6368
400	7.82	34.25	0.65	26.73	139	.7295	400	6.97	34.29	0.68	26.88	124	.7678
500	6.62	34.30	0.46	26.94	120	.8590							
Station 17. August 23, 1938; 0300. Lat. 33°16'N, long. 118°59'W. Wind: W 3. Sea: moderate							Station 20. August 24, 1938; 0030. Lat. 32°39'N, long. 119°59'W. Wind: WNW 3. Sea: Moderate						
0	18.88	33.67	5.21	24.06	387		0	17.60	33.22	5.54	24.02	390	
10	18.90	33.68	6.32	24.05	387	.0387	10	17.58	33.22	5.47	24.03	389	.0390
25	13.88	33.35	5.99	24.95	302	.0904	25	17.59	33.22	5.41	24.03	390	.0974
50	11.80	33.40	4.88	25.40	260	.1606	50	14.34	33.26	6.07	24.79	318	.1859
75	10.54	33.65	3.81	25.82	220	.2206	75	12.64	33.36	5.62	25.21	278	.2604
100	9.70	33.76	3.27	26.05	198	.2728	100	10.69	33.56	4.35	25.73	230	.3239
150	8.91	33.92	2.29	26.30	175	.3660	150	9.20	33.73	3.78	26.11	194	.4299
200	8.60	34.11	1.69	26.50	157	.4490	200	8.33	33.98	2.82	26.44	163	.5191
250	8.35	34.20	1.33	26.61	148	.5252	250	7.90	34.10	1.85	26.60	149	.5971
300	7.85	34.28	0.70	26.75	136	.5962	300	7.54	34.16	1.24	26.70	140	.6693
400	7.11	34.30	0.49	26.88	125	.7267	400	6.85	34.25	0.51	26.87	125	.8018
500	6.45	34.34	0.40	26.99	114	.8462	500	6.33	34.32	0.29	27.00	114	.9213
Station 18. August 23, 1938; 0800. Lat. 33°02'N, long. 119°16'.5 W. Wind: WNW 2. Sea: light							Station 21. August 24, 1938; 0530. Lat. 32°30'N, long. 120°15'W. Wind: WNW 3. Sea: moderate						
0	17.40	33.62	5.70	24.38	356		0	17.90	33.22	5.48	23.96	396	
10	16.99	33.58	5.85	24.44	350	.0353	10	17.82	33.23	5.41	23.98	394	.0395
25	16.98	33.54	5.82	24.41	354	.0881	25	16.02	33.28	5.74	24.44	351	.0954
50	12.65	33.42	5.60	25.25	274	.1666	50	13.08	33.22	5.77	25.02	296	.1763
75	11.10	33.58	4.60	25.67	235	.2302	75	11.90	33.32	5.30	25.32	268	.2468
100	9.80	33.71	3.51	25.99	204	.2851	100	10.46	33.48	4.50	25.70	232	.3093
150	8.95	33.90	2.62	26.28	177	.3803	150	8.58	33.80	3.27	26.26	179	.4121
200	8.67	34.12	1.68	26.50	158	.4641	200	7.90	33.90	2.86	26.44	162	.4973
250	8.33	34.20	1.08	26.61	147	.5403	250	7.37	33.96	2.15	26.56	151	.5755
300	7.88	34.24	0.72	26.72	139	.6118	300	6.94	34.04	1.53	26.69	140	.6483
400	7.10	34.30	0.50	26.88	124	.7433	400	6.27	34.16	0.64	26.87	124	.7803
500	6.44	34.29	0.40	26.95	118	.8643	500	5.68	34.20	0.45	26.98	115	.8998
Station 18A. August 23, 1938; 1300. Lat. 32°54' .5 N, long. 119°30'.5 W. Wind: WNW 3-4. Sea: moderate							Station 22. August 24, 1938; 1000. Lat. 32°21'N, long. 120°31'W. Wind: NW 3. Sea: moderate						
0	17.38	33.58	5.73	24.36	358		0	17.80	33.54	5.60	24.22	371	
10	17.26	33.58	5.83	24.38	356	.0357	10	17.67	33.52	5.59	24.23	370	.0370
25	17.02	33.59	5.79	24.44	350	.0887	25	17.00	33.46	5.60	24.35	359	.0917
50	12.20	33.46	5.23	25.37	262	.1652	50	12.75	33.11	6.08	25.00	298	.1738
75	10.88	33.53	4.50	25.67	234	.2272	75	11.75	33.42	5.35	25.43	258	.2433
100	10.12	33.66	3.92	25.90	213	.2831	100	10.78	33.69	4.45	25.81	221	.3032
150	8.78	34.00	2.17	26.38	168	.3783	150	9.30	33.87	2.77	26.20	185	.4047
200	8.38	34.10	2.13	26.53	155	.4591	200	8.50	33.94	2.72	26.38	168	.4929
250	8.22	34.14	1.54	26.58	150	.5353	250	7.58	34.03	2.00	26.60	149	.5721
300	8.04	34.24	0.98	26.69	141	.6081	300	6.99	34.06	1.38	26.70	140	.6443
400	7.30	34.25	0.57	26.80	131	.7441	400	6.03	34.10	0.70	26.85	126	.7773
500	6.63	34.29	0.43	26.93	120	.8696	500	5.50	34.16	0.38	26.97	116	.8983

Depth (m.) (dbars)	Tempera- ture (°C.)	Salin- ity (‰)	Oxy- gen (ml/L.)	σ_t	$10^6 \delta$	ΔD (dyn. m.)	Depth (m.) (dbars)	Tempera- ture (°C.)	Salin- ity (‰)	Oxy- gen (ml/L.)	σ_t	$10^6 \delta$	ΔD (dyn. m.)
Station 23. August 24, 1938; 1700. Lat. 32°03' .5 N, long. 120°58'W. Wind: WNW 3. Sea: heavy							Station 27A. August 25, 1938; 2330. Lat. 32°00'N, long. 118°44'W. Wind: NW 2. Sea: moderate						
0	18.07	33.31	5.61	23.98	394		0	18.25	33.52	5.59	24.09	383	
10	17.95	33.30	5.62	24.00	393	.0394	10	18.26	33.60	5.45	24.15	378	.0380
25	17.94	33.27	5.65	23.98	394	.0984	25	18.00	33.61	5.43	24.22	371	.0942
50	16.67	33.22	5.73	24.24	370	.1939	50	13.50	33.22	4.72	24.93	304	.1786
75	14.50	33.20	6.07	24.71	326	.2809	75	12.30	33.55	5.35	25.42	258	.2488
100	13.21	33.37	5.68	25.11	289	.3578	100	10.70	33.50	4.07	25.68	234	.3103
150	9.76	33.70	3.44	25.99	205	.4813	150	8.67	33.82	3.19	26.26	179	.4135
200	8.18	33.90	3.24	26.40	167	.5743	200	8.06	34.01	2.61	26.50	157	.4975
250	7.63	34.00	2.20	26.56	152	.6541	250	8.02	34.18	1.37	26.64	144	.5727
300	7.23	34.09	1.62	26.69	141	.7273	300	7.90	34.24	0.85	26.71	139	.6435
400	6.37	34.12	0.85	26.83	128	.8618	400	7.11	34.28	0.66	26.85	126	.7760
500	5.60	34.16	0.50	26.96	117	.9843	500	6.28	34.31	0.43	26.99	114	.8960
Station 24. August 25, 1938; 0400. Lat. 31°18'N, long. 120°02'W. Wind: WNW 2-3. Sea: moderate							Station 28. August 26, 1938; 0330. Lat. 32°05'N, long. 118°22'W. Wind: W 1. Sea: light						
0	18.76	33.64	5.46	24.06	386		0	18.85	33.68	5.55	24.07	386	
10	18.74	33.64	5.52	24.06	386	.0386	10	18.79	33.66	5.57	24.07	386	.0386
25	18.50	33.68	5.38	24.15	378	.0959	25	14.48	33.32	6.27	24.80	316	.0912
50	12.30	33.40	5.40	25.31	268	.1767	50	12.60	33.43	5.35	25.27	272	.1647
75	10.82	33.61	4.35	25.74	228	.2387	75	11.52	33.59	4.45	25.60	241	.2288
100	9.97	33.65	3.62	25.92	211	.2936	100	10.45	33.75	3.60	25.92	212	.2854
150	8.42	34.01	2.34	26.45	161	.3866	150	8.72	33.91	2.95	26.33	173	.3816
200	7.53	34.07	1.92	26.63	145	.4631	200	8.10	34.01	2.76	26.50	157	.4641
250	7.14	34.13	1.43	26.74	136	.5333	250	7.76	34.15	1.54	26.66	143	.5391
300	7.00	34.24	0.89	26.84	126	.5988	300	7.64	34.24	0.93	26.75	135	.6086
400	6.20	34.21	0.59	26.92	119	.7213	400	7.04	34.28	0.72	26.86	125	.7386
500	5.46	34.26	0.39	27.05	108	.8348	500	6.41	34.33	0.50	26.99	114	.8581
Station 25. August 25, 1938; 1200. Lat. 31°39'N, long. 119°33'W. Wind: NW 3. Sea: moderate							Station 28A. August 26, 1938; 0700. Lat. 32°11'N, long. 118°06'W. Wind: WNW 1. Sea: light						
0	19.10	33.45	5.44	23.83	408		0	19.05	33.69	6.03	24.02	390	
10	19.05	33.52	5.33	23.89	402	.0405	10	18.94	33.68	5.43	24.04	388	.0389
25	18.80	33.55	5.30	23.98	394	.1002	25	15.90	33.63	6.11	24.73	323	.0922
50	15.10	33.18	6.02	24.56	340	.1920	50	12.14	33.66	4.50	25.54	246	.1633
75	13.55	33.41	5.95	25.07	292	.2710	75	10.10	33.72	3.68	25.95	208	.2201
100	11.62	33.45	5.11	25.47	254	.3392	100	9.24	33.82	3.07	26.17	187	.2695
150	9.35	33.81	3.35	26.15	190	.4502	150	8.46	34.00	2.50	26.44	163	.3570
200	8.43	34.00	2.19	26.44	163	.5384	200	8.25	33.99	1.63	26.46	161	.4380
250	7.96	34.08	1.60	26.57	151	.6169	250	7.68	34.18	1.22	26.69	139	.5130
300	7.80	34.17	1.20	26.67	143	.6904	300	7.54	34.23	1.04	26.75	135	.5815
400	6.59	34.19	0.75	26.85	126	.8249	400	6.87	34.25	0.52	26.86	125	.7115
500	6.09	34.20	0.43	26.93	120	.9479	500	6.28	34.27	0.43	26.96	117	.8325
Station 27. August 25, 1938; 1900. Lat. 31°53'N, long. 119°01'W. Wind: WNW 2. Sea: moderate							Station 29. August 26, 1938; 1100. Lat. 32°17'N, long. 117°50'W. Wind: SW 0-1. Sea: light						
0	17.70	33.24	5.52	24.01	390		0	19.30	33.72	5.89	23.98	394	
10	17.53	33.22	5.50	24.04	388	.0389	10	18.79	33.68	5.47	24.08	384	.0389
25	17.25	33.20	5.75	24.09	384	.0968	25	18.69	33.66	5.54	24.09	382	.0963
50	14.05	33.30	6.03	24.88	309	.1834	50	13.19	33.52	5.27	25.22	276	.1785
75	11.95	33.29	5.30	25.29	271	.2559	75	10.95	33.52	4.38	25.65	236	.2425
100	10.65	33.56	4.32	25.73	229	.3184	100	9.70	33.71	3.30	26.01	202	.2973
150	9.15	33.77	3.51	26.15	190	.4232	150	8.92	33.89	2.78	26.28	178	.3923
200	8.12	34.04	2.61	26.52	156	.5097	200	8.48	34.06	1.75	26.48	159	.4765
250	8.14	34.19	1.22	26.63	146	.5852	250	8.00	34.13	1.44	26.61	148	.5533
300	7.57	34.24	0.74	26.76	134	.6552	300	7.55	34.18	1.04	26.71	138	.6248
400	6.91	34.29	0.43	26.89	123	.7837	400	6.85	34.25	0.55	26.87	125	.7563
500	6.38	34.31	0.35	26.98	116	.9032	500	6.14	34.30	0.43	27.00	113	.8753

RECORDS OF OBSERVATIONS, SCRIPPS INSTITUTION OF OCEANOGRAPHY

Depth (m.) (dbars)	Tempera- ture (°C.)	Salin- ity (°/oo)	Oxy- gen (ml/L.)	σ_t	$10^5\delta$	ΔD (dyn. m.)	Depth (m.) (dbars)	Tempera- ture (°C.)	Salin- ity (°/oo)	Oxy- gen (ml/L.)	σ_t	$10^5\delta$	ΔD (dyn. m.)
Station 30. August 26, 1938; 1430. Lat. 32°25'N, long. 117°36'W. Wind: W 0-1. Sea: light							Station 31. August 26, 1938; 1700. Lat. 32°31'N, long. 117°26'W. Wind: W 0-1. Sea: light						
0	19.70	33.46	5.56	23.68	422		0	21.26	33.60	5.56	23.37	452	
10	18.79	33.49	5.59	23.94	398	.0410	10	20.25	33.58	5.42	23.63	427	.0444
25	17.74	33.47	5.76	24.18	375	.0990	25	16.25	33.36	6.03	24.45	350	.1022
50	13.30	33.17	6.12	24.93	304	.1839	50	14.10	33.41	6.05	24.95	302	.1837
75	12.35	33.37	5.42	25.27	272	.2559	75	11.35	33.53	4.33	25.58	243	.2518
100	11.25	33.58	4.27	25.64	238	.3197	100	10.65	33.58	3.70	25.75	227	.3106
150	9.43	33.81	3.25	26.13	192	.4272	150	9.86	33.79	2.46	26.05	200	.4174
200	8.36	33.95	2.78	26.41	166	.5167	200	9.37	34.10	1.67	26.37	170	.5099
250	7.73	34.04	2.16	26.58	151	.5959	250	8.70	34.14	1.63	26.51	158	.5919
300	7.38	34.08	1.78	26.66	144	.6697	300	7.68	34.15	1.78	26.68	142	.6669
400	6.68	34.17	1.34	26.83	128	.8057	400	7.22	34.24	0.88	26.81	131	.8034
500	6.26	34.28	0.40	26.97	116	.9277	500	6.33	34.24	0.59	26.93	120	.9289

Cruise V

Depth (m.) (dbars)	Tempera- ture (°C.)	Salin- ity (‰)	Oxy- gen (ml/L.)	σ_t	$10^5 \delta$	ΔD (dyn. m.)	Depth (m.) (dbars)	Tempera- ture (°C.)	Salin- ity (‰)	Oxy- gen (ml/L.)	σ_t	$10^5 \delta$	ΔD (dyn. m.)
Station 1. October 26, 1938; 2130. Lat. 35°01'N, long. 121°00'W. Wind: NW 0-1. Sea: light							Station 5. October 27, 1938; 1300. Lat. 34°30'.5 N, long. 121°52'.5 W. Wind: 0-1. Sea: light						
0	15.60	33.45	5.82	24.66	329		0	17.38	33.35	5.50	24.17	376	
10	15.28	33.40	5.92	24.69	326	.0328	10	17.07	33.31	5.67	24.22	372	.0374
25	12.74	33.35	5.42	25.18	280	.0782	25	16.47	33.37	5.70	24.40	354	.0918
50	11.05	33.46	4.50	25.58	242	.1434	50	11.32	33.12	5.90	25.28	272	.1700
75	10.31	33.68	3.48	25.88	214	.2004	75	10.26	33.34	4.82	25.63	238	.2338
100	10.00	33.75	3.10	25.99	204	.2526	100	9.38	33.65	3.76	26.02	202	.2888
150	9.00	33.96	2.50	26.32	174	.3471	150	8.41	33.85	3.33	26.33	173	.3826
200	8.34	34.09	1.81	26.52	155	.4293	200	7.68	33.95	26.51	156	.4648
Station 2. October 27, 1938; 0130. Lat. 34°55'N, long. 121°09'W. Wind: 0. Sea: light							Station 6. October 27, 1938; 1800. Lat. 34°10'N, long. 122°25'W. Wind: 0. Sea: light						
0	13.93	33.53	5.79	25.08	289		0	17.20	33.39	5.65	24.25	368	
10	13.44	33.54	5.75	25.19	279	.0284	10	16.86	33.38	4.97	24.32	362	.0365
25	13.16	33.55	5.61	25.25	273	.0698	25	15.45	33.32	5.83	24.59	336	.0889
50	11.28	33.60	4.70	25.66	236	.1334	50	11.44	33.15	5.82	25.27	272	.1649
75	9.90	33.71	3.65	25.98	205	.1885	75	10.38	33.25	5.40	25.54	247	.2298
100	9.57	33.82	3.12	26.12	192	.2381	100	9.57	33.55	4.31	25.91	212	.2872
150	8.85	33.97	2.38	26.35	171	.3289	150	8.46	33.92	3.10	26.37	169	.3824
200	8.29	34.11	1.88	26.55	153	.4099	200	7.74	33.99	2.64	26.53	154	.4632
250	7.82	34.12	1.59	26.62	146	.4847	250	7.01	34.00	2.48	26.65	144	.5377
300	7.36	34.19	1.33	26.75	135	.5549	300	6.74	34.07	1.70	26.74	136	.6077
400	6.40	34.21	0.77	26.89	122	.6834	400	5.78	34.14	0.95	26.92	120	.7357
500	5.65	34.27	0.44	27.04	109	.7989	500	5.32	34.24	0.58	27.05	107	.8492
Station 3. October 27, 1938; 0430. Lat. 34°49' .5 N, long. 121°19'W. Wind: 0. Sea: light							Station 7. October 28, 1938; 0000. Lat. 33°52'N, long. 122°55'W. Wind: SSW 2. Sea: light						
0	16.43	33.43	5.65	24.46	348		0	17.40	33.23	5.66	24.08	385	
10	16.05	33.45	5.73	24.56	339	.0344	10	17.26	33.17	5.58	24.07	386	.0386
25	15.00	33.42	5.92	24.78	319	.0838	25	17.27	33.16	5.48	24.05	388	.0966
50	10.87	33.16	5.60	25.38	262	.1564	50	13.62	33.13	5.39	24.84	314	.1844
75	10.03	33.37	4.70	25.69	232	.2182	75	11.68	33.21	5.47	25.28	272	.2576
100	9.20	33.67	3.90	26.06	198	.2720	100	10.62	33.35	5.02	25.57	244	.3221
150	8.35	33.91	3.20	26.38	168	.3635	150	8.92	33.84	3.25	26.24	182	.4286
200	7.53	34.09	2.10	26.64	144	.4415	200	8.16	33.94	3.54	26.43	164	.5151
250	7.10	34.10	1.70	26.71	138	.5120	250	7.32	34.03	2.40	26.63	146	.5926
300	6.72	34.15	1.25	26.80	130	.5790	300	6.89	34.13	1.35	26.76	133	.6624
400	5.83	34.21	0.81	26.97	115	.7015	400	6.08	34.17	0.78	26.90	121	.7894
500	5.56	34.27	0.52	27.05	108	.8130	500	5.24	34.22	0.49	27.05	108	.9039
Station 4. October 27, 1938; 0930. Lat. 34°39'.5 N, long. 121°38' W. Wind: SE 0-1. Sea: light							Station 8. October 28, 1938; 0930. Lat. 33°12'N, long. 121°50'.5 W. Wind: SSE 0-1. Sea: light						
0	16.55	33.37	5.63	24.38	356		0	17.60	33.63	5.46	24.34	360	
10	16.16	33.41	5.64	24.50	344	.0350	10	17.36	33.69	5.49	24.44	351	.0356
25	15.55	33.51	5.76	24.72	324	.0851	25	16.53	33.58	5.60	24.55	340	.0874
50	12.15	33.19	6.03	25.17	282	.1609	50	11.49	33.47	4.44	25.51	249	.1610
75	10.33	33.26	5.19	25.56	245	.2268	75	10.12	33.60	3.87	25.86	217	.2192
100	9.62	33.66	3.95	25.99	205	.2830	100	9.34	33.83	2.92	26.16	188	.2698
150	8.10	33.94	2.67	26.44	162	.3748	150	8.43	33.99	2.46	26.43	163	.3576
200	7.45	33.96	2.79	26.55	152	.4533	200	7.86	34.08	2.11	26.59	149	.4356
250	7.03	34.03	1.65	26.67	142	.5268	250	7.32	34.10	1.68	26.68	141	.5081
300	6.74	34.05	1.18	26.72	137	.5966	300	7.12	34.19	0.98	26.78	132	.5763
400	6.07	34.13	0.83	26.87	124	.7271	400	6.46	34.22	0.57	26.90	122	.7033
500	5.28	34.15	0.47	26.99	114	.8461	500	5.77	34.29	0.32	27.04	109	.8188

Depth (m.) (dbars)	Tempera- ture (°C.)	Salin- ity (°/oo)	Oxy- gen (ml/L.)	σ_t	$10^5 \delta$	ΔD (dyn. m.)	Depth (m.) (dbars)	Tempera- ture (°C.)	Salin- ity (°/oo)	Oxy- gen (ml/L.)	σ_t	$10^5 \delta$	ΔD (dyn. m.)
Station 9. October 28, 1938; 1400. Lat. 33°26'N, long. 121°24'.5 W. Wind: SE 1. Sea: moderate							Station 12. October 29, 1938; 0300. Lat. 33°54'N, long. 120°28'W. Wind: 1-2. Sea: light						
0	17.80	33.62	5.45	24.28	365		0	17.67	33.46	5.39	24.19	374	
10	17.42	33.53	5.42	24.30	364	.0364	10	17.51	33.51	5.46	24.27	367	.0370
25	17.11	33.53	5.51	24.38	357	.0905	25	17.19	33.52	5.35	24.35	360	.0915
50	12.10	33.45	4.64	25.38	262	.1679	50	12.06	33.19	5.46	25.19	280	.1715
75	10.07	33.66	3.62	25.92	212	.2271	75	11.40	33.37	4.49	25.46	256	.2385
100	9.00	33.88	3.03	26.26	179	.2760	100	9.66	33.67	3.76	25.99	205	.2961
150	8.10	33.93	2.82	26.43	163	.3615	150	8.87	33.90	2.32	26.29	176	.3913
200	7.76	34.02	1.98	26.56	152	.4403	200	8.38	34.09	1.67	26.52	156	.4743
250	7.47	34.09	1.33	26.65	144	.5143	250	7.50	34.11	1.76	26.66	142	.5488
300	7.25	34.20	0.90	26.77	133	.5835	300	7.04	34.15	1.40	26.76	134	.6178
400	6.27	34.27	0.55	26.96	116	.7080	400	6.52	34.18	0.74	26.85	126	.7478
500	5.72	34.29	0.35	27.05	109	.8205	500	5.95	34.30	0.45	27.02	111	.8663
Station 9A. October 28, 1938; 1700. Lat. 33°32'N, long. 120°12'W. Wind: SE 1. Sea: moderate							Station 13. October 26, 1938; 1100. Lat. 34°08'.5 N, long. 120°04' W. Wind: NW 0-1. Sea: smooth						
0	17.60	33.65	5.38	24.36	359		0	14.60	33.54	6.91	24.95	302	
10	17.26	33.59	5.54	24.39	356	.0358	10	14.20	33.60	6.50	25.08	290	.0296
25	16.87	33.55	5.15	24.45	350	.0888	25	13.60	33.63	5.64	25.23	276	.0720
50	12.24	33.52	4.45	25.41	259	.1649	50	11.38	33.59	4.36	25.63	238	.1362
75	10.54	33.68	3.75	25.84	218	.2245	75	10.47	33.78	3.44	25.93	210	.1922
100	9.31	33.77	3.14	26.12	192	.2757	100	10.17	33.81	2.85	26.01	203	.2438
150	8.34	33.95	3.14	26.41	165	.3649	150	9.14	33.91	1.98	26.26	180	.3396
200	7.78	33.97	2.67	26.51	156	.4451	200	8.77	34.07	1.37	26.44	163	.4254
250	7.24	34.01	1.95	26.62	146	.5206	250	8.48	34.18	0.88	26.57	152	.5042
300	6.80	34.12	1.48	26.78	133	.5904	300	7.92	34.19	0.71	26.67	143	.5780
400	6.41	34.25	0.79	26.93	119	.7164	400	6.90	34.25	0.45	26.86	126	.7125
500	5.78	34.32	0.69	27.06	107	.8294							
Station 10. October 28, 1938; 2000. Lat. 33°38' .5 N, long. 120°59'W. Wind: S 1. Sea: light							Station 15. October 30, 1938; 2000. Lat. 33°34'N, long. 118°29'.5 W. Wind: W 1. Sea: smooth						
0	17.72	33.58	5.50	24.27	366		0	17.13	33.53	5.70	24.37	357	
10	17.39	33.64	5.64	24.39	355	.0360	10	16.87	33.55	5.64	24.45	350	.0354
25	16.43	33.55	5.54	24.55	340	.0881	25	15.26	33.51	5.88	24.78	318	.0855
50	11.32	33.31	5.26	25.42	258	.1629	50	12.33	33.48	5.31	25.36	264	.1583
75	10.31	33.45	4.81	25.71	231	.2240	75	10.98	33.55	3.98	25.67	235	.2207
100	9.52	33.67	3.86	26.01	203	.2782	100	10.11	33.79	3.07	26.00	203	.2755
150	8.53	33.94	2.77	26.38	168	.3710	150	8.97	33.97	2.53	26.33	173	.3695
200	8.12	34.08	1.79	26.55	153	.4512	200	8.65	34.06	1.93	26.45	162	.4533
250	7.34	34.07	1.81	26.66	143	.5252	250	8.36	34.15	1.28	26.57	152	.5318
300	6.54	34.05	1.64	26.75	135	.5947	300	7.89	34.29	0.86	26.75	136	.6038
400	5.86	34.16	0.80	26.92	119	.7217	400	7.03	34.29	0.64	26.87	125	.7343
500	5.64	34.27	0.31	27.04	109	.8357	500	6.25	34.36	0.35	27.03	110	.8518
Station 11. October 28, 1938; 2330. Lat. 33°45' .5 N, long. 120°43'W. Wind: NE 1. Sea: light							Station 16. October 31, 1938. 0000. Lat. 33°25'N, long. 118°44'W. Wind: 0. Sea: smooth						
0	17.90	33.35	5.40	24.05	387		0	17.05	33.44	5.70	24.32	362	
10	17.81	33.43	5.40	24.13	380	.0384	10	16.94	33.46	5.64	24.36	358	.0360
25	17.69	33.35	5.46	24.10	383	.0956	25	14.18	33.34	5.98	24.88	309	.0860
50	12.80	33.11	5.77	24.99	299	.1808	50	11.06	33.29	5.14	25.45	255	.1565
75	11.13	33.25	5.30	25.41	260	.2507	75	10.24	33.63	3.99	25.86	217	.2155
100	9.40	33.60	(4.40)	25.37	206	.3089	100	9.68	33.77	3.50	26.06	198	.2674
150	8.70	33.90	(3.20)	26.32	174	.4039	150	8.50	33.95	2.84	26.39	167	.3586
200	8.03	34.05	2.59	26.54	154	.4859	200	8.44	34.09	1.80	26.51	157	.4396
250	7.17	34.05	2.55	26.66	142	.5599	250	8.02	34.14	1.50	26.61	148	.5158
300	6.68	34.07	2.10	26.75	136	.6294	300	7.85	34.26	0.99	26.74	137	.5870
400	6.10	34.14	0.78	26.88	124	.7594	400	7.12	34.31	0.55	26.88	124	.7175
500	5.63	34.23	0.40	27.01	112	.8774	500	6.41	34.36	0.30	27.01	112	.8355

Depth (m.) (dbars)	Tempera- ture (°C.)	Salin- ity (°/oo)	Oxy- gen (ml/L.)	σ_t	$10^6 \delta$	ΔD (dyn. m.)	Depth (m.) (dbars)	Tempera- ture (°C.)	Salin- ity (°/oo)	Oxy- gen (ml/L.)	σ_t	$10^6 \delta$	ΔD (dyn. m.)
Station 17, October 31, 1938; 0300. Lat. 33°17'N, 119°00'W. Wind: W 2-3. Sea: light							Station 24, November 4, 1938; 1230. Lat. 31°13'N, long. 119°56'W. Wind: NW 4-5. Sea: moderate						
0	16.97	33.43	5.68	24.33	360		0	18.40	33.43	5.38	23.99	393	
10	16.29	33.47	5.98	24.52	343	.0352	10	18.30	33.43	5.37	24.01	391	.0392
25	15.14	33.51	5.79	24.81	316	.0846	25	18.25	33.42	5.55	24.02	391	.0978
50	10.92	33.41	4.71	25.57	244	.1546	50	16.80	33.42	5.68	24.36	359	.1916
75	10.18	33.60	3.95	25.84	218	.2124	75	13.20	33.28	5.80	25.04	295	.2734
100	9.48	33.67	3.53	26.02	202	.2649	100	11.65	33.44	5.02	25.46	255	.3422
150	8.38	33.95	2.72	26.41	165	.3567	150	10.10	33.70	4.30	25.94	211	.4587
200	8.00	34.10	1.89	26.58	150	.4355	200	7.81	33.93	3.56	26.48	159	.5512
250	7.96	34.20	1.29	26.67	142	.5085	250	7.42	34.03	2.75	26.61	147	.6277
300	7.62	34.22	1.00	26.73	137	.5783	300	7.17	34.08	1.82	26.69	141	.6997
400	7.04	34.29	0.62	26.87	125	.7093	400	6.44	34.16	0.86	26.85	126	.8332
500	6.26	34.33	0.59	27.01	113	.8283	500	5.69	34.25	0.45	27.02	111	.9517
Station 18, October 31, 1938; 0730. Lat. 33°09'N, long. 119°14'.5 W. Wind: WNW 3. Sea: moderate							Station 25, November 4, 1938; 0730. Lat. 31°28'N, long. 119°26'W. Wind: NW 4-5. Sea: heavy						
0	16.60	33.45	5.67	24.43	351		0	18.64	33.58	5.41	24.04	388	
10	16.17	33.41	5.64	24.50	345	.0348	10	18.49	33.50	5.96	24.02	391	.0390
25	14.20	33.35	5.88	24.89	308	.0838	25	18.50	33.57	5.43	24.07	386	.0973
50	12.05	33.54	4.40	25.46	254	.1540	50	18.35	33.59	5.40	24.12	382	.1933
75	10.45	33.65	3.52	25.84	219	.2131	75	13.10	33.51	6.30	25.23	276	.2755
100	9.32	33.71	3.00	26.07	196	.2650	100	11.20	33.48	5.33	25.57	244	.3405
150	8.39	33.87	2.30	26.34	171	.3568	150	9.23	33.80	3.09	26.16	189	.4487
200	7.95	34.04	1.50	26.54	153	.4378	200	8.77	34.02	2.25	26.40	167	.5377
250	7.87	34.14	0.92	26.63	146	.5126	250	8.30	34.12	1.70	26.55	153	.6177
300	7.64	34.22	0.69	26.73	137	.5834	300	7.63	34.17	1.28	26.69	141	.6912
400	7.00	34.29	0.52	26.88	124	.7139	400	6.88	34.23	0.73	26.85	127	.8252
500	6.25	34.30	0.41	26.99	115	.8334	500	6.23	34.28	0.27	26.97	116	.9467
Station 18A, October 31, 1938; 1100. Lat. 33°02'N, long. 119°29'W. Wind: WNW 4. Sea: moderate							Station 27, November 4, 1938; 0230. Lat. 31°43'N, long. 118°57'W. Wind: NW 2. Sea: moderate						
0	16.93	33.53	6.09	24.42	352		0	17.20	33.41	5.61	24.26	367	
10	16.86	33.51	5.72	24.42	352	.0352	10	17.05	33.33	5.62	24.24	370	.0368
25	16.60	33.48	5.79	24.46	349	.0878	25	16.94	33.41	5.58	24.32	362	.0917
50	12.18	33.16	5.70	25.14	284	.1669	50	15.30	33.25	6.00	24.57	339	.1793
75	11.25	33.45	4.95	25.54	247	.2333	75	12.96	33.42	5.45	25.19	280	.2567
100	9.97	33.57	4.15	25.86	217	.2913	100	11.24	33.45	4.90	25.54	247	.3226
150	8.83	33.90	2.88	26.30	176	.3895	150	9.72	33.76	3.34	26.05	200	.4344
200	8.09	34.01	2.15	26.50	158	.4730	200	8.75	34.06	2.41	26.44	164	.5254
250	7.63	34.08	1.74	26.62	146	.5490	250	8.45	34.15	1.79	26.56	153	.6046
300	7.30	34.13	1.34	26.71	139	.6202	300	7.87	34.21	1.35	26.69	141	.6781
400	7.05	34.24	0.50	26.84	129	.7542	400	6.92	34.29	0.70	26.89	123	.8101
500	6.10	34.27	26.98	115	.8762	500	6.13	34.31	0.42	27.01	112	.9276
Station 19, October 31, 1938; 1530. Lat. 32°53'.5 N, long. 119°41' W. Wind: W 3-4. Sea: moderate							Station 27A, November 3, 1938; 2230. Lat. 31°51'N, long. 118°41'W. Wind: NW 3-4. Sea: moderate						
0	17.15	33.45	5.66	24.31	363		0	17.15	33.55	5.69	24.38	356	
10	17.14	33.53	5.63	24.37	357	.0360	10	16.85	33.56	5.54	24.46	349	.0352
25	16.50	33.48	5.60	24.48	347	.0888	25	16.50	33.43	5.69	24.44	351	.0877
50	13.30	33.12	5.85	24.89	308	.1707	50	12.57	33.18	5.80	25.08	292	.1678
75	11.60	33.16	5.62	25.25	274	.2435	75	11.60	33.52	4.55	25.53	248	.2350
100	10.20	33.45	4.70	25.72	230	.3065	100	9.96	33.66	3.55	25.93	210	.2922
150	9.28	33.86	3.16	26.19	186	.4105	150	8.91	33.92	2.64	26.30	176	.3887
200	8.76	33.94	2.82	26.34	173	.5003	200	8.13	33.98	2.55	26.48	160	.4727
250	7.85	33.97	2.18	26.50	158	.5831	250	7.62	34.03	1.95	26.58	150	.5502
300	7.08	34.00	1.84	26.64	146	.6591	300	7.10	34.08	(1.32)	26.70	140	.6227
400	6.24	34.15	0.95	26.87	125	.7946	400	6.45	34.19	(0.71)	26.87	124	.7547
500	5.63	34.22	0.51	27.00	113	.9136	500	5.94	34.29	(0.36)	27.02	112	.8727

Depth (m.) (dbars)	Tempera- ture (°C.)	Salin- ity (‰)	Oxy- gen (ml/L.)	σ_t	$10^5 \delta$	ΔD (dyn. m.)	Depth (m.) (dbars)	Tempera- ture (°C.)	Salin- ity (‰)	Oxy- gen (ml/L.)	σ_t	$10^5 \delta$	ΔD (dyn. m.)
Station 28. November 3, 1938; 1900. Lat. $31^{\circ}59'N$, long. $118^{\circ}23'.5 W$. Wind: NW 2. Sea: moderate							Station 30. November 5, 1938; 0730. Lat. $32^{\circ}23'N$, long. $117^{\circ}39'W$. Wind: WSW 1. Sea: moderate						
0	17.02	33.63	5.69	24.47	347		0	16.38	33.58	5.90	24.58	336	
10	17.22	33.55	5.70	24.36	358	.0352	10	16.16	33.51	5.87	24.58	337	.0336
25	16.85	33.59	5.70	24.48	347	.0881	25	14.08	33.35	6.02	24.92	306	.0818
50	12.20	33.51	5.20	25.42	259	.1639	50	11.50	33.49	4.60	25.52	248	.1510
75	10.58	33.70	4.15	25.85	217	.2234	75	10.63	33.71	3.33	25.85	217	.2091
100	9.73	33.77	3.33	26.05	198	.2753	100	9.92	33.80	2.99	26.05	199	.2611
150	8.77	33.97	2.35	26.36	170	.3673	150	9.13	34.02	2.32	26.35	172	.3539
200	8.32	34.11	1.90	26.54	154	.4483	200	8.58	34.08	1.67	26.48	160	.4369
250	8.13	34.18	1.66	26.63	146	.5233	250	8.15	34.18	1.30	26.62	147	.5137
300	7.72	34.21	1.10	26.72	139	.5945	300	7.62	34.26	0.76	26.77	134	.5839
400	6.91	34.27	0.61	26.87	124	.7260	400	6.69	34.28	0.60	26.91	121	.7116
500	6.35	34.27	0.38	26.95	118	.8470	500	6.13	34.31	0.22	27.01	112	.8279
Station 28A. November 3, 1938; 1500. Lat. $32^{\circ}07'N$, long. $118^{\circ}10'.5 W$. Wind: NW 2. Sea: moderate							Station 31. November 5, 1938; 1130. Lat. $32^{\circ}31'$.5 N, long. $117^{\circ}25'.5 W$. Wind: NW 0-1. Sea: smooth						
0	18.08	33.54	5.61	24.16	378		0	16.89	33.57	5.73	24.46	348	
10	17.67	33.57	5.52	24.27	366	.0372	10	16.38	33.56	5.70	24.57	338	.0343
25	17.31	33.61	5.36	24.39	356	.0914	25	14.12	33.52	4.95	25.03	294	.0817
50	11.00	33.68	4.75	25.76	225	.1640	50	11.62	33.57	4.49	25.56	244	.1489
75	9.70	33.71	3.00	26.01	202	.2174	75	10.37	33.65	3.82	25.85	217	.2065
100	9.11	33.87	2.73	26.23	182	.2654	100	9.70	33.73	3.31	26.03	201	.2587
150	8.75	34.06	1.86	26.44	163	.3516	150	9.02	34.01	2.38	26.36	170	.3515
200	8.07	34.13	1.40	26.60	148	.4294	200	8.56	34.11	1.68	26.50	157	.4333
250	7.67	34.16	1.10	26.68	141	.5016	250	8.28	34.23	1.21	26.64	145	.5085
300	7.48	34.23	0.84	26.76	134	.5704	300	7.70	34.27	0.98	26.76	134	.5783
400	6.60	34.29	0.43	26.93	119	.6969	400	(6.98)	34.31	0.53	26.90	122	.7063
500	6.09	34.37	0.36	27.06	107	.8099	500	(6.25)	34.35	0.31	27.03	111	.8228
Station 29. November 3, 1938; 1200. Lat. $32^{\circ}15'N$, long. $117^{\circ}57'W$. Wind: NNW 3-4. Sea: moderate													
0	17.32	33.52	5.73	24.32	362								
10	16.92	33.45	5.73	24.36	358	.0360							
25	14.60	33.37	6.25	24.82	315	.0865							
50	11.27	33.53	4.35	25.60	241	.1560							
75	10.00	33.68	3.50	25.94	209	.2122							
100	9.18	33.87	2.68	26.22	182	.2611							
150	8.53	34.08	2.08	26.49	158	.3461							
200	8.11	34.11	1.77	26.57	150	.4231							
250	7.95	34.19	1.13	26.66	143	.4963							
300	7.57	34.20	0.75	26.73	138	.5665							
400	6.75	34.21	0.47	26.85	127	.6990							
500	6.17	34.23	0.27	26.94	119	.8220							

Cruise VI

Depth (m.) (dbars)	Tempera- ture (°C.)	Salin- ity (‰)	Oxy- gen (ml/L.)	σ_t	$10^5 \delta$	ΔD (dyn. m.)	Depth (m.) (dbars)	Tempera- ture (°C.)	Salin- ity (‰)	Oxy- gen (ml/L.)	σ_t	$10^5 \delta$	ΔD (dyn. m.)
Station 1. December 9, 1938; 2030. Lat. 35°01' .5 N, long. 120°56'W. Wind: 0-1. Sea: light							Station 5. December 10, 1938; 1100. Lat. 34°27'N, long. 121°52'.5 W. Wind: NW 2-3. Sea: heavy						
0	13.95	33.50	5.97	25.05	291		0	14.50	33.42	(3.57)	24.88	308	
10	13.76	33.46	5.97	25.06	291	.0291	10	15.09	33.45	(3.48)	24.77	318	.0313
25	13.44	33.52	6.05	25.17	281	.0720	25	14.35	33.44	(3.84)	24.93	304	.0779
50	13.20	33.46	5.65	25.18	281	.1422	50	11.47	33.44	(3.34)	25.49	251	.1473
75	12.45	33.50	5.15	25.35	264	.2103	75	10.24	33.63	(2.04)	25.86	216	.2057
100	10.52	33.63	3.90	25.82	221	.2709	100	9.51	33.69	(1.67)	26.03	201	.2578
150	8.92	33.92	2.56	26.30	175	.3699	150	8.73	34.03	(1.34)	26.42	164	.3490
200	8.45	34.09	1.68	26.51	157	.4529	200	8.16	34.07	(1.32)	26.54	154	.4285
250	8.14	34.14	1.62	26.59	149	.5294	250	7.82	34.17	(0.96)	26.66	142	.5025
							300	7.46	34.21	(1.15)	26.75	135	.5717
							400	6.60	34.22	(0.49)	26.88	124	.7012
							500	5.83	34.25	(0.45)	27.00	113	.8197
Station 2. December 9, 1938; 2330. Lat. 34°55'N, long. 121°07'W. Wind: 1. Sea: moderate							Station 6. December 10, 1938; 1730. Lat. 34°10'N, long. 122°25'W. Wind: WNW 4. Sea: rough						
0	13.50	33.50	5.94	25.15	282		0	14.45	33.45	5.96	24.91	305	
10	13.34	33.52	5.90	25.19	278	.0280	10	14.35	33.40	5.89	24.89	307	.0306
25	13.11	33.47	5.78	25.20	278	.0697	25	14.36	33.47	5.92	24.95	302	.0763
50	12.43	33.49	5.16	25.36	264	.1375	50	13.70	33.44	5.70	25.06	292	.1505
75	11.35	33.52	4.42	25.58	243	.2009	75	10.82	33.51	4.44	25.66	235	.2164
100	10.08	33.60	3.57	25.86	217	.2584	100	9.72	33.74	3.56	26.03	200	.2708
150	9.03	33.81	3.03	26.20	185	.3589	150	8.64	33.87	2.93	26.31	175	.3646
200	8.11	33.94	3.03	26.44	163	.4459	200	7.97	33.97	2.60	26.49	158	.4478
250	7.82	34.11	1.78	26.62	147	.5234	250	7.33	34.06	2.00	26.65	144	.5233
300	7.63	34.20	1.09	26.72	138	.5946	300	6.99	34.12	1.48	26.74	135	.5931
400	6.69	34.21	0.68	26.86	126	.7266	400	6.41	34.19	0.71	26.88	124	.7226
500	5.81	34.24	0.45	26.99	113	.8461	500	5.67	34.22	0.52	27.00	113	.8411
Station 3. December 10, 1938; 0330. Lat. 34°46'N, long. 121°22'.5 W. Wind: WNW 3. Sea: moderate							Station 7. December 10, 1938; 2300. Lat. 33°51'N, long. 122°55'W. Wind: NW 2-3. Sea: moderate						
0	14.70	33.46	5.98	24.87	309		0	14.70	33.41	5.93	24.83	313	
10	14.65	33.44	5.94	24.86	310	.0310	10	14.58	33.36	5.91	24.81	315	.0314
25	14.15	33.52	6.27	25.03	295	.0764	25	14.60	33.36	5.87	24.81	315	.0786
50	12.74	33.45	5.21	25.26	273	.1474	50	13.75	33.41	5.90	25.03	295	.1548
75	10.30	33.73	3.75	25.93	210	.2078	75	10.85	33.41	4.55	25.58	243	.2220
100	9.64	33.79	3.20	26.07	196	.2586	100	9.58	33.61	3.90	25.95	208	.2784
150	8.87	33.96	2.71	26.34	172	.3506	150	8.43	33.93	2.64	26.39	167	.3722
200	8.21	34.06	2.19	26.52	155	.4324	200	7.72	33.96	2.72	26.52	155	.4527
250	7.90	34.19	1.40	26.67	142	.5066	250	6.92	33.97	2.23	26.63	145	.5277
300	7.22	34.20	1.21	26.77	132	.5751	300	6.53	34.05	1.50	26.76	134	.5975
400	5.87	34.18	0.75	26.94	117	.6996	400	5.69	34.12	0.84	26.91	120	.7245
500	5.27	34.25	0.40	27.07	106	.8111	500	5.23	34.23	0.40	27.06	107	.8380
Station 4. December 10, 1938; 0700. Lat. 34°36'.5 N, long. 121°37'.5 W. Wind: NW 4. Sea: heavy							Station 8. December 11, 1938; 0900. Lat. 32°55'N, long. 122°03'.5 W. Wind: NW 0-1. Sea: moderate						
0	14.87	33.46	5.86	24.83	313		0	15.00	33.38	5.86	24.74	321	
10	14.72	33.50	5.84	24.89	307	.0310	10	14.87	33.38	5.86	24.77	319	.0320
25	14.25	33.44	5.80	24.95	302	.0767	25	14.84	33.37	5.85	24.77	320	.0799
50	12.55	33.43	5.27	25.28	271	.1483	50	13.38	33.25	5.87	24.98	300	.1574
75	11.20	33.56	4.55	25.63	238	.2119	75	11.01	33.38	4.97	25.53	248	.2259
100	9.87	33.73	3.25	26.00	204	.2671	100	9.71	33.59	4.19	25.92	211	.2833
150	8.72	33.98	2.75	26.38	168	.3601	150	8.54	33.89	2.65	26.34	172	.3791
200	7.81	34.04	2.53	26.56	151	.4399	200	8.03	34.09	2.04	26.57	150	.4596
250	7.26	34.04	1.92	26.64	144	.5137	250	7.68	34.14	1.70	26.66	142	.5326
300	6.82	34.06	1.50	26.72	137	.5839	300	7.10	34.18	1.32	26.78	132	.6011
400	6.17	34.14	0.93	26.87	124	.7144	400	6.07	34.23	0.75	26.95	116	.7251
500	5.69	34.23	0.54	27.00	113	.8329	500	5.52	34.33	0.47	27.10	103	.8346

Depth (m.) (dbars)	Temperature (°C.)	Salinity (°/oo)	Oxygen (ml/L.)	σ_t	$10^6 \delta$	ΔD (dyn. m.)	Depth (m.) (dbars)	Temperature (°C.)	Salinity (°/oo)	Oxygen (ml/L.)	σ_t	$10^6 \delta$	ΔD (dyn. m.)
Station 9. December 11, 1938; 1500. Lat. 33°16'N, long. 121°31'W. Wind: WNW 0-1. Sea: moderate							Station 12. December 12, 1938; 0600. Lat. 33°54' .5 N, long. 120°27'.5 W. Wind: ESE 1. Sea: moderate						
0	14.85	33.46	5.87	24.83	312		0	14.00	33.52	5.91	25.06	291	
10	14.71	33.46	6.04	24.86	310	.0311	10	13.81	33.50	5.86	25.08	289	.0290
25	14.63	33.43	5.93	24.86	311	.0777	25	13.72	33.50	5.81	25.10	288	.1723
50	12.22	33.46	5.51	25.37	263	.1495	50	11.33	33.54	4.48	25.60	241	.1384
75	10.98	33.49	4.71	25.62	239	.2123	75	10.26	33.67	3.60	25.89	214	.1953
100	9.97	33.73	3.62	25.98	205	.2678	100	9.57	33.76	3.19	26.07	196	.2465
150	8.53	33.90	2.60	26.35	171	.3618	150	8.93	33.92	2.51	26.30	176	.3395
200	7.73	34.12	1.92	26.64	144	.4406	200	8.33	34.11	1.72	26.54	153	.4217
250	7.33	34.17	1.48	26.74	135	.5104	250	8.19	34.19	1.35	26.62	146	.4965
300	6.64	34.18	1.39	26.84	126	.5756	300	7.90	34.21	1.03	26.68	141	.5683
400	5.81	34.20	0.78	26.96	115	.6961	400	7.02	34.24	0.80	26.83	128	.7028
500	5.33	34.26	0.43	27.07	106	.8066	500	5.91	34.27	0.50	27.00	112	.8228
Station 9A. December 11, 1938; 1830. Lat. 33°25'N, long. 121°16'.5 W. Wind: WNW 1. Sea: moderate							Station 13. December 9, 1938; 1030. Lat. 34°09'N, long. 120°04'W. Wind: 0. Sea: smooth.						
0	15.10	33.42	5.90	24.75	320		0	14.40	33.51	6.47	24.97	300	
10	14.97	33.38	5.92	24.75	321	.0320	10	14.14	33.53	6.40	25.04	293	.0296
25	14.92	33.35	5.88	24.73	323	.0803	25	13.35	33.47	5.85	25.15	283	.0728
50	11.85	33.33	5.12	25.34	266	.1539	50	12.21	33.51	5.04	25.41	259	.1406
75	10.43	33.59	4.12	25.79	222	.2149	75	10.68	33.63	3.93	25.78	224	.2010
100	9.54	33.73	3.75	26.05	198	.2671	100	9.95	33.77	3.19	26.02	202	.2542
150	8.53	33.86	3.70	26.32	174	.3601	150	9.21	33.88	2.46	26.22	183	.3504
200	7.71	33.97	2.70	26.52	155	.4423	200	8.75	34.06	1.59	26.44	163	.4369
250	7.13	34.05	2.40	26.67	142	.5165	250	8.28	34.10	1.43	26.54	154	.5161
300	6.87	34.15	1.42	26.78	131	.5847	300	7.89	34.19	0.94	26.67	143	.5903
400	5.95	34.20	0.78	26.94	117	.7087	400	7.07	34.20	0.60	26.80	132	.7278
500	5.31	34.25	0.50	27.06	106	.8202							
Station 10. December 11, 1938; 2200. Lat. 33°34'N, long. 121°02'W. Wind: 0. Sea: light							Station 15. December 14, 1938; 0600. Lat. 33°35' .5 N, long. 118°33'W. Wind: SE 1. Sea: light						
0	14.88	33.48	5.95	24.84	312		0	15.75	33.55	5.79	24.70	325	
10	14.71	33.50	5.93	24.89	307	.0310	10	15.58	33.52	5.87	24.72	324	.0324
25	14.72	33.44	6.02	24.85	312	.0774	25	15.47	33.57	5.86	24.78	318	.0806
50	12.17	33.26	5.84	25.22	276	.1509	50	15.35	33.42	5.25	24.69	327	.1612
75	10.82	33.30	5.24	25.50	250	.2167	75	11.23	33.59	4.27	25.65	236	.2316
100	9.90	33.58	4.25	25.88	215	.2748	100	10.55	33.68	3.76	25.84	218	.2884
150	8.68	33.92	2.94	26.34	172	.3716	150	9.40	33.90	2.70	26.21	184	.3889
200	7.77	34.00	2.77	26.54	153	.4528	200	8.77	34.08	1.95	26.45	162	.4754
250	7.16	34.04	2.33	26.66	143	.5268	250	8.13	34.18	1.38	26.63	146	.5524
300	6.84	34.08	1.52	26.73	136	.5966	300	7.83	34.23	1.10	26.71	139	.6236
400	6.10	34.19	0.76	26.92	120	.7246	400	7.17	34.28	0.55	26.84	127	.7566
500	5.58	34.30	0.39	27.07	106	.8376	500	6.28	34.32	0.28	27.00	114	.8771
Station 11. December 12, 1938; 0230. Lat. 33°44'.5N, long. 120°43' W. Wind: SE 1. Sea: moderate							Station 16. December 14, 1938; 0200. Lat. 33°26'N, long. 118°47'W. Wind: ESE 2. Sea: light						
0	14.80	33.39	6.02	24.80	316		0	15.05	33.58	5.98	24.88	308	
10	14.68	33.35	5.98	24.78	317	.0316	10	14.85	33.54	6.08	24.90	307	.0308
25	14.65	33.38	5.80	24.81	315	.0790	25	14.45	33.54	5.98	24.98	299	.0762
50	12.08	33.22	5.76	25.21	278	.1531	50	11.71	33.59	4.29	25.56	244	.1441
75	10.53	33.39	4.88	25.62	239	.2177	75	10.63	33.66	3.70	25.81	221	.2022
100	9.62	33.83	3.35	26.12	192	.2716	100	9.93	33.86	2.95	26.10	195	.2542
150	8.75	34.03	2.22	26.41	165	.3608	150	9.15	33.98	2.50	26.32	175	.3467
200	8.30	34.15	1.85	26.58	150	.4396	200	8.57	34.10	1.90	26.50	158	.4299
250	8.03	34.18	1.26	26.64	145	.5134	250	8.37	34.14	1.51	26.56	153	.5077
300	7.64	34.22	0.95	26.74	137	.5839	300	7.91	34.22	1.19	26.70	141	.5812
400	(6.07)	34.18	1.03	26.91	120	.7124	400	7.13	34.30	0.59	26.87	125	.7142
500	5.76	34.29	0.40	27.04	109	.8269	500	6.17	34.32	0.36	27.01	112	.8327

Depth (m.) (dbars)	Tempera- ture (°C.)	Salin- ity (‰)	Oxy- gen (ml/L.)	σ_t	$10^5 \delta$	ΔD (dyn. m.)	Depth (m.) (dbars)	Tempera- ture (°C.)	Salin- ity (‰)	Oxy- gen (ml/L.)	σ_t	$10^5 \delta$	ΔD (dyn. m.)
Station 17. December 13, 1938; 2200. Lat. 33°17'N, long. 119°01'.5 W. Wind: E 1. Sea: smooth							Station 20. December 13, 1938; 0930. Lat. 32°43' .5 N, long. 119°57'W. Wind: ESE 4. Sea: mod- erate						
0	14.35	33.52	6.08	24.99	298		0	16.20	33.46	5.70	24.53	341	
10	14.06	33.50	6.12	25.04	294	.0296	10	16.00	33.40	5.77	24.53	341	.0341
25	14.42	33.54	5.80	24.99	298	.0740	25	15.98	33.47	5.74	24.59	336	.0849
50	11.60	33.55	4.72	25.55	245	.1419	50	15.55	33.38	5.77	24.62	334	.1687
75	10.01	33.64	3.86	25.90	212	.1990	75	12.25	33.26	5.60	25.21	278	.2452
100	9.37	33.76	3.22	26.10	193	.2496	100	11.28	33.42	5.05	25.51	250	.3112
150	8.50	33.94	2.91	26.38	168	.3398	150	9.67	33.83	3.93	26.11	194	.4222
200	8.02	34.02	2.20	26.52	156	.4208	200	8.24	33.97	3.34	26.45	162	.5112
250	7.63	34.14	1.52	26.67	142	.4953	250	7.58	34.01	2.22	26.57	151	.5894
300	7.43	34.23	1.03	26.77	133	.5641	300	7.05	34.06	1.35	26.69	140	.6622
400	6.88	34.30	0.50	26.90	122	.6916	400	6.33	34.17	0.70	26.87	124	.7942
500	6.16	34.33	0.34	27.02	111	.8081	500	5.74	34.28	0.38	27.03	109	.9107
Station 18. December 13, 1938; 1900. Lat. 33°09' .5 N, long. 119°15'W. Wind: 0. Sea: smooth							Station 21. December 13, 1938; 0530. Lat. 32°33' .5 N, long. 120°12'W. Wind: ESE 3. Sea: moderate						
0	14.35	33.54	6.16	25.00	296		0	16.60	33.54	5.60	24.50	344	
10	14.13	33.51	6.17	25.02	294	.0295	10	16.56	33.52	5.65	24.50	345	.0344
25	12.93	33.52	5.82	25.28	271	.0719	25	16.15	33.49	5.67	24.57	338	.0856
50	10.15	33.62	3.77	25.87	215	.1327	50	15.65	33.43	5.72	24.64	333	.1695
75	9.25	33.86	3.06	26.20	184	.1826	75	13.55	33.32	5.70	25.00	298	.2484
100	8.93	33.92	2.83	26.30	175	.2275	100	11.50	33.44	5.05	25.49	252	.3172
150	8.57	34.07	2.17	26.47	159	.3110	150	9.36	33.78	3.58	26.12	193	.4284
200	8.17	34.10	1.86	26.56	152	.3888	200	8.31	33.95	3.10	26.42	165	.5179
250	7.88	34.16	1.37	26.65	144	.4628	250	8.16	34.12	1.73	26.57	151	.5969
300	7.80	34.26	0.86	26.74	136	.5328	300	7.72	34.19	1.15	26.69	140	.6697
400	6.97	34.34	0.45	26.92	120	.6608	400	6.57	34.23	0.68	26.89	123	.8012
500	6.08	34.34	0.28	27.04	109	.7753	500	5.78	34.25	0.40	27.01	112	.9187
Station 18A. December 13, 1938; 1530. Lat. 33° 01'N, long. 119°30'.5 W. Wind: ESE 3. Sea: light							Station 22. December 13, 1938; 0230. Lat. 32°23'N, long. 120°27'.5 W. Wind: SSE 1. Sea: moderate						
0	14.35	33.52	6.12	24.99	298		0	16.90	33.50	5.62	24.40	353	
10	14.16	33.50	6.12	25.01	296	.0297	10	16.83	33.52	5.70	24.43	351	.0352
25	12.81	33.47	5.50	25.26	272	.0723	25	16.86	33.52	5.61	24.43	352	.0879
50	10.52	33.62	4.42	25.80	221	.1339	50	15.84	33.36	5.75	24.54	342	.1747
75	10.08	33.69	4.13	25.93	209	.1877	75	13.68	33.36	5.81	25.00	298	.2547
100	9.00	33.85	3.15	26.23	181	.2365	100	12.15	33.42	5.24	25.35	265	.3251
150	8.46	33.98	2.55	26.42	164	.3227	150	9.76	33.69	3.81	25.99	206	.4429
200	8.02	34.03	2.69	26.53	155	.4025	200	8.31	33.88	3.23	26.36	170	.5369
250	7.68	34.17	2.56	26.69	140	.4763	250	7.54	34.00	2.80	26.57	151	.6171
300	7.58	34.26	1.26	26.77	133	.5445	300	6.95	34.03	1.92	26.68	141	.6901
400	7.05	34.28	0.62	26.86	126	.6740	400	6.26	34.19	0.71	26.90	122	.8216
500	6.17	34.32	0.36	27.01	112	.7930	500	5.69	34.26	0.41	27.02	110	.9376
Station 19. December 13, 1938; 1230. Lat. 32°55'N, long. 119°42'W. Wind: SE 3. Sea: moderate							Station 23. December 12, 1938; 2100. Lat. 32°04'N, long. 120°57'W. Wind: SSE 2. Sea: moderate						
0	14.70	33.40	5.88	24.82	314		0	17.00	33.51	5.84	24.39	355	
10	14.91	33.38	5.84	24.76	320	.0317	10	16.85	33.52	5.65	24.43	351	.0353
25	14.63	33.38	5.92	24.82	314	.0793	25	16.86	33.48	5.70	24.40	355	.0883
50	14.22	33.46	5.93	24.97	301	.1562	50	16.93	33.57	5.68	24.45	350	.1764
75	10.44	33.40	4.76	25.64	237	.2234	75	11.66	33.56	4.84	25.56	246	.2509
100	9.66	33.77	3.29	26.06	197	.2776	100	10.50	33.68	4.20	25.85	217	.3088
150	8.56	33.88	2.98	26.33	173	.3701	150	9.00	33.85	3.45	26.23	182	.4086
200	8.22	34.01	2.39	26.48	159	.4531	200	7.80	33.97	2.98	26.51	156	.4931
250	7.72	34.08	1.82	26.61	148	.5299	250	7.23	34.02	2.52	26.63	145	.5683
300	7.28	34.20	1.24	26.77	133	.6001	300	6.98	34.12	1.45	26.75	135	.6383
400	6.50	34.27	0.61	26.93	119	.7261	400	6.36	34.25	0.69	26.93	118	.7648
500	5.82	34.29	0.42	27.03	110	.8406	500	5.65	34.28	0.44	27.05	108	.8778

Depth (m.) (dbars)	Tempera- ture (°C.)	Salin- ity (°/oo)	Oxy- gen (ml/L.)	σ_t	$10^5 \delta$	ΔD (dyn. m.)	Depth (m.) (dbars)	Tempera- ture (°C.)	Salin- ity (°/oo)	Oxy- gen (ml/L.)	σ_t	$10^5 \delta$	ΔD (dyn. m.)
Station 24. December 17, 1938; 1130. Lat. 31°09'N, long. 119°58'W. Wind: SE 3. Sea: moderate							Station 28. December 18, 1938; 0530. Lat. 31°58' .5 N, long. 118°25'W. Wind: SE 2. Sea: moderate						
0	17.30	33.56	5.76	24.35	358		0	15.80	33.48	5.74	24.64	331	
10	17.14	33.54	5.72	24.38	356	.0357	10	15.59	33.48	5.76	24.69	327	.0328
25	17.15	33.48	6.36	24.33	361	.0895	25	15.00	33.48	5.85	24.82	315	.0811
50	17.17	33.48	5.59	24.32	362	.1799	50	11.70	33.41	5.10	25.43	257	.1526
75	15.11	33.38	6.23	24.72	326	.2659	75	10.48	33.64	3.96	25.82	220	.2122
100	12.97	33.32	5.86	25.11	288	.3427	100	9.45	33.76	3.47	26.09	195	.2641
150	10.43	33.63	4.64	25.33	221	.4699	150	8.52	33.99	2.79	26.42	164	.3539
200	8.80	33.84	3.63	26.26	180	.5701	200	7.93	34.10	2.15	26.59	148	.4319
250	7.88	34.00	2.96	26.52	156	.6541	250	7.64	34.19	1.25	26.71	138	.5034
300	7.28	34.05	2.24	26.65	144	.7291	300	7.37	34.22	0.82	26.77	133	.5712
400	6.24	34.14	1.21	26.86	125	.8636	400	6.67	34.29	0.50	26.92	120	.6977
500	5.61	34.23	0.60	27.01	112	.9821	500	5.94	34.32	0.30	27.04	109	.8122
Station 25. December 17, 1938; 1700. Lat. 31°27'N, long. 119°25'.5 W. Wind: SE 3. Sea: moderate							Station 28A. December 18, 1938; 0900. Lat. 32°08' .5 N, long. 118°12'W. Wind: SE 2. Sea: moderate						
0	16.70	33.48	5.61	24.44	350		0	15.45	33.40	5.78	24.66	329	
10	16.53	33.48	5.65	24.47	347	.0348	10	15.27	33.42	5.95	24.71	324	.0326
25	15.88	33.40	5.76	24.56	339	.0862	25	14.98	33.48	5.86	24.82	314	.0804
50	15.20	33.38	5.80	24.70	327	.1694	50	13.63	33.46	5.81	25.09	289	.1558
75	12.65	33.31	5.65	25.17	282	.2455	75	10.92	33.40	4.82	25.56	245	.2226
100	11.37	33.54	4.75	25.59	243	.3111	100	9.94	33.68	3.72	25.95	208	.2792
150	9.22	33.79	3.47	26.15	190	.4193	150	8.90	33.96	2.48	26.34	172	.3742
200	8.54	34.01	2.70	26.43	164	.5078	200	8.65	34.07	1.80	26.46	161	.4574
250	8.24	34.20	1.66	26.63	146	.5853	250	8.03	34.20	1.23	26.66	143	.5334
300	7.89	34.22	1.32	26.69	141	.6571	300	7.38	34.24	0.97	26.78	132	.6022
400	7.05	34.30	0.60	26.88	124	.7896	400	6.69	34.27	0.51	26.90	121	.7287
500	6.03	34.31	0.42	27.02	111	.9071	500	6.02	34.32	0.33	27.04	110	.8442
Station 27. December 17, 1938; 2230. Lat. 31°43'N, long. 118°56'W. Wind: SE 2. Sea: light							Station 29. December 18, 1938; 1200. Lat. 32°20'N, long. 117°55'.5 W. Wind: SE 2-3. Sea: moderate						
0	15.60	33.59	5.81	24.77	318		0	15.20	33.44	5.84	24.74	321	
10	15.43	33.60	5.79	24.81	315	.0316	10	14.80	33.44	5.85	24.83	313	.0317
25	15.40	33.56	5.81	24.79	317	.0790	25	14.25	33.42	5.47	24.93	304	.0780
50	10.45	33.74	3.58	25.91	211	.1450	50	11.50	33.51	5.00	25.54	246	.1468
75	9.50	33.84	3.16	26.14	189	.1950	75	10.61	33.58	4.32	25.76	226	.2058
100	9.09	33.96	2.75	26.31	174	.2404	100	9.70	33.82	3.28	26.10	194	.2578
150	8.32	34.00	2.71	26.46	161	.3242	150	8.90	34.01	2.62	26.37	168	.3483
200	7.48	34.06	2.38	26.63	145	.4007	200	8.26	34.11	2.27	26.55	152	.4283
250	7.35	34.18	1.25	26.74	135	.4707	250	8.14	34.22	1.27	26.66	143	.5021
300	7.22	34.23	0.75	26.80	130	.5369	300	7.83	34.28	0.90	26.75	135	.5716
400	6.36	34.25	0.52	26.93	118	.6609	400	6.83	34.32	0.62	26.92	119	.6986
500	5.77	34.30	0.40	27.05	108	.7739	500	6.21	34.36	0.45	27.04	110	.8131
Station 27A. December 18, 1938; 0200. Lat. 31°51'N, long. 118°40'.5 W. Wind: SE 3. Sea: moderate							Station 30. December 18, 1938; 1500. Lat. 32°26'N, long. 117°40'W. Wind: SE 5. Sea: rough						
0	15.70	33.54	5.72	24.71	324		0	15.45	33.46	5.81	24.70	325	
10	15.49	33.51	5.71	24.73	322	.0323	10	15.27	33.47	5.85	24.76	321	.0323
25	15.48	33.51	5.77	24.73	322	.0806	25	15.05	33.51	5.87	24.83	314	.0799
50	11.27	33.60	4.24	25.65	236	.1504	50	13.10	33.40	5.70	25.15	283	.1545
75	9.90	33.70	3.24	25.98	206	.2056	75	11.42	33.42	4.88	25.49	252	.2214
100	9.23	33.81	2.69	26.17	188	.2548	100	10.23	33.67	3.94	25.90	214	.2796
150	8.29	33.98	2.20	26.44	162	.3423	150	9.28	33.87	2.77	26.20	185	.3794
200	7.98	34.14	1.62	26.62	146	.4193	200	8.96	34.07	1.84	26.41	166	.4672
250	7.80	34.20	1.14	26.69	140	.4908	250	8.37	34.21	1.28	26.61	147	.5454
300	7.38	34.23	0.91	26.78	132	.5588	300	7.84	34.25	0.96	26.72	137	.6164
400	6.38	34.26	0.50	26.94	118	.6838	400	6.98	34.28	0.60	26.87	125	.7474
500	5.88	34.30	0.30	27.03	110	.7978	500	6.31	34.33	0.33	27.00	113	.8664

Depth (m.) (dbars)	Tempera- ture (°C.)	Salin- ity (°/oo)	Oxy- gen (ml/L.)	σ_t	$10^5 \delta$	ΔD (dyn. m.)
Station 31. December 18, 1938; 1700. Lat. 32°31'.5 N, long. 117°27'.5 W. Wind: SE 5. Sea: rough						
0	16.30	33.58	5.61	24.60	334	
10	15.98	33.50	5.77	24.61	334	.0334
25	15.78	33.48	5.67	24.64	331	.0833
50	14.60	33.59	5.60	24.99	299	.1621
75	12.48	33.49	4.93	25.34	266	.2327
100	11.48	33.70	3.60	25.69	233	.2951
150	10.34	33.91	2.28	26.06	199	.4031
200	9.13	34.07	2.05	26.38	168	.4949
250	8.47	34.13	1.68	26.54	155	.5757
300	8.03	34.19	1.27	26.65	145	.6507
400	7.32	34.28	0.62	26.82	129	.7877
500

TABLE B

Interpolated Values of Phosphate-Phosphorus Content at Standard Depths
(microgram atoms per kilogram)

Cruise I

Depth (m.) (dbars)	Stations														
	1	2	3	4	5	6	7	8	9	9A	10	15	16	17	18
0	0.57	0.56	0.63	0.39	0.39	0.47	0.35	0.46	0.19	0.28	0.46	0.37	0.41	0.34	0.32
10	0.56	0.54	0.52	0.35	0.41	0.61	0.34	0.48	0.37	0.36	0.48	0.37	0.42	0.33	0.34
25	0.55	0.56	0.50	0.37	0.36	0.40	0.42	0.50	0.47	0.35	0.49	0.47	0.49	0.60	0.66
50	0.65	0.68	1.20	0.75	0.39	0.49	0.44	0.68	0.43	0.40	0.62	0.73	0.77	1.17	1.22
75	1.21	1.46	1.90	1.42	1.00	0.80	0.83	1.51	0.88	0.59	0.70	1.08	0.96	1.97	1.97
100	1.57	2.21	2.18	1.81	1.41	2.02	0.83	2.06	0.87	0.52	1.50	1.50	1.58	2.23	2.23
150	2.17	2.31	2.22	1.95	1.65	2.49	1.45	2.18	1.38	1.55	1.86	1.71	1.73	2.86	2.86
200	2.45	2.41	2.14	2.30	2.22	2.31	1.49	2.81	1.52	1.75	2.40	1.84	1.76	2.92	2.92
250	2.53	2.40	2.36	2.20	2.61	1.76	2.98	1.85	2.59	2.14	2.08	2.98	2.98
300	2.59	2.61	2.71	2.74	1.94	2.89	2.06	2.80	2.63	2.72	3.42	3.42
400	2.77	2.71	3.14	2.91	2.14	3.12	2.37	3.03	2.47	2.50	3.23	3.23
500	2.78	2.89	3.34	3.07	2.44	3.12	2.96	3.42	2.58	2.52	3.28	3.28

Depth (m.) (dbars)	Stations														
	18A	19	20	21	22	23	24	25	27	27A	28	28A	29	30	31
0	0.38	0.37	0.36	0.37	0.36	0.37	0.32	0.31	0.49	0.46	0.46	0.45	0.37	0.37	0.39
10	0.46	0.40	0.31	0.33	0.31	0.32	0.32	0.32	0.41	0.37	0.43	0.46	0.39	0.37	0.37
25	0.52	0.52	0.37	0.38	0.34	0.35	0.33	0.34	0.34	0.34	0.56	0.57	0.42	0.40	0.34
50	0.66	0.62	0.44	0.43	0.42	0.44	0.39	0.38	0.46	0.47	0.57	0.73	0.52	0.53	0.77
75	0.96	1.04	0.50	0.70	0.66	0.70	0.36	0.36	0.66	0.67	1.10	1.10	1.13	1.14	1.25
100	1.16	1.30	0.83	0.92	0.96	1.22	0.45	0.45	0.96	1.18	1.76	1.30	1.91	1.78	1.52
150	1.54	1.73	1.33	1.00	1.80	1.80	1.06	1.08	0.81	0.97	1.30	1.81	2.61	2.81	1.85
200	1.69	1.90	1.88	1.83	2.13	2.14	1.99	1.95	0.89	0.93	1.76	1.95	2.72	2.43	2.03
250	1.78	2.03	1.95	1.95	2.40	2.47	1.99	2.01	2.28	1.09	1.79	1.97	2.55	2.57	2.01
300	1.79	2.23	2.20	2.13	2.58	2.53	2.21	2.22	2.44	1.43	2.68	2.64	2.44	2.55	1.99
400	2.47	3.30	2.49	2.55	3.22	3.09	2.62	2.64	3.22	3.13	2.01	1.91	2.41	2.52	1.96
500	3.40	2.54	2.97	3.03	2.95	2.82	2.94	3.25	3.29	3.30	3.33	2.93	2.88	2.48

Cruise II

Depth (m.) (dbars)	Stations														
	1	2	3	4	5	6	25	27	27A	28	28A	29	30	31	
0	0.66	0.53	0.46	0.46	0.47	0.50	0.36	0.35	0.36	0.35	0.41	0.37	0.32	0.31	
10	0.65	0.38	0.48	0.46	0.47	0.36	0.36	0.34	0.36	0.32	0.34	0.44	0.47	
25	0.96	0.66	0.54	0.48	0.49	0.37	0.37	0.31	0.31	0.34	0.36	0.48	1.03	
50	0.96	0.88	0.69	0.52	0.49	0.40	0.46	0.45	0.43	0.54	0.61	1.03	1.30	
75	1.40	1.45	0.90	0.85	0.80	0.48	0.56	0.56	0.59	1.25	1.32	1.61	1.85	
100	1.40	1.36	1.20	1.08	1.53	0.60	0.64	0.81	0.80	1.63	1.60	1.79	2.02	
150	1.41	2.18	1.74	1.66	1.60	1.65	1.23	1.03	1.06	2.00	1.99	1.76	1.87	
200	1.88	1.85	1.81	1.75	1.73	1.77	1.35	1.48	1.67	2.06	1.99	2.34	2.31	
250	1.96	1.78	2.17	1.82	1.93	1.88	1.80	1.93	1.94	1.85	2.31	2.31	
300	2.07	1.81	2.43	1.88	2.07	2.32	2.16	2.48	1.91	2.11	3.26	3.22	
400	2.24	1.83	2.57	2.08	2.28	2.95	2.89	2.98	2.62	2.40	3.23	3.18	
500	2.41	2.10	2.59	2.43	2.43	2.93	2.90	3.03	3.14	3.16	3.00	3.14	

Cruise III

Depth (m.) (dbars)	Stations															
	1	2	3	4	5	6	7	8	9	9A	10	11	12	13	15	16
0	0.75	0.71	0.67	0.72	0.71	0.63	0.63	0.68	0.68	0.53	0.54	0.63	0.63	0.62	0.53	0.53
10	0.80	1.17	0.71	0.72	0.70	0.68	0.68	0.70	0.70	0.54	0.54	0.68	0.69	0.59	0.55	0.56
25	1.10	1.40	0.83	0.63	0.63	0.72	0.71	0.70	0.71	0.57	0.58	0.68	0.71	0.90	0.59	0.63
50	2.40	2.06	2.00	0.68	0.89	0.75	0.73	0.74	0.77	0.70	0.70	0.71	0.75	1.40	1.32	0.71
75	2.90	2.23	2.22	2.31	2.37	1.50	1.50	0.84	1.50	0.94	0.96	1.01	1.15	1.80	2.10	1.22
100	3.17	2.95	2.75	2.37	3.47	2.00	2.00	2.13	2.18	2.20	2.15	2.20	2.23	2.16	2.20	2.34
150	3.29	3.59	3.25	3.30	3.45	2.19	2.15	2.26	2.22	2.27	2.27	2.31	2.44	2.22	2.37	2.37
200	3.82	3.51	3.58	3.60	2.37	2.32	2.34	2.30	2.35	2.46	2.41	2.55	2.47	2.47	2.44
250	3.95	3.76	3.71	3.50	2.50	2.55	2.40	2.70	2.57	2.45	3.82	3.43	2.52	3.30	2.54
300	4.17	3.98	3.50	3.60	3.50	3.24	3.19	3.07	3.65	3.70	3.76	3.60	2.58	3.60	3.24
400	4.31	3.78	3.88	3.57	3.38	3.23	3.30	3.71	3.66	4.20	3.90	3.65	3.60
500	4.49	3.85	3.88	3.75	3.75	3.47	3.49	3.74	3.66	4.60	4.20	3.70	4.13

Depth (m.) (dbars)	Stations																
	17	18	18A	19	20	21	22	23	24	25	27	27A	28	28A	29	30	31
0	0.54	0.70	0.62	0.41	0.43	0.40	0.40	0.39	0.39	0.43	0.44	0.46	0.46	0.46	0.46	0.34	0.40
10	0.57	0.53	0.54	0.47	0.46	0.42	0.41	0.39	0.38	0.45	0.45	0.47	0.48	0.48	0.47	0.29	0.29
25	0.61	0.71	0.80	0.53	0.52	0.52	0.53	0.39	0.42	0.46	0.47	0.51	0.51	0.50	0.50	0.29	0.53
50	0.70	1.16	1.22	0.57	0.55	0.52	0.54	0.42	0.43	0.90	0.91	0.90	0.87	0.51	0.57	1.00	1.02
75	1.25	1.30	1.41	0.80	0.80	0.53	0.55	0.44	0.45	1.05	1.25	1.80	1.95	1.25	1.70	1.02	1.03
100	2.31	2.37	2.38	1.13	1.05	0.92	0.96	0.81	0.83	1.04	1.20	2.08	2.10	1.95	1.91	1.13	1.22
150	2.37	2.47	2.48	1.86	1.30	1.25	1.24	1.50	2.97	2.20	2.31	2.57	2.44	1.95	2.14	1.79	1.27
200	2.47	2.78	2.94	2.20	2.50	2.37	1.74	2.20	3.38	2.27	2.26	2.62	2.08	2.37	2.48	1.89	1.89
250	2.50	3.05	3.20	3.28	3.01	2.22	2.12	2.52	3.50	2.33	2.23	2.41	2.62	2.43	2.50	2.47	2.50
300	3.16	3.60	3.76	3.43	3.27	2.28	2.28	3.36	3.51	2.55	2.31	3.08	2.19	2.64	2.70	2.83	2.83
400	3.52	3.45	3.68	3.74	3.60	3.96	3.20	3.50	3.55	3.70	3.51	3.30	3.30	3.86	3.42	3.26	3.08
500	4.08	3.59	3.46	3.40	3.78	4.48	4.70	3.57	3.85	3.70	3.82	3.78	3.30	3.40	3.43	3.31

TABLE C

Table C presents the results of the phytoplankton collections made by means of an Allen Closing Bottle with a capacity of 5 liters. In the table, column A gives the number of diatoms per liter (p = present); column B, the percentage of diatoms in poor condition.

PLANKTON DIATOMS

Depth (m.)	Cruises												
	I		II		III		IV		V		VI		
	A	B	A	B	A	B	A	B	A	B	A	B	
Station 1													
0	p		61320	1.8	1280	3.1	p		p		p		
10	p		82680	0.0	500	8.0	p		p		p		
20	p		40680	1.5	360	11.1	p		p		p		
30	p		50720	1.7	3140	1.3	p		p		p		
40	p		15720	2.5			p		p		p		
50	p		10320	3.1	2040	4.9	p		p		p		
60	p		4920	3.2			p		p		p		
70					100	20.0							
Station 2													
0	p		115920	7.7	860	16.3	p		p		p		
10	p		144200	6.2	1020	2.0	p		p		p		
20	p		101120	10.3	1680	3.6	p		p		p		
30	p		14880	17.2	980	4.1	p		p		p		
40	p		17080	6.6			p		p		p		
50	p		6800	18.2	1700	20.0	p		p		p		
60	p		3960	6.1			p		p		p		
70					1180	10.2							
Station 3													
0	p		22800	13.0	2140	22.4	p		p		23700	6.1	
10	p		12160	3.6	1500	26.7	p		p		22560	10.8	
20	p		9000	12.9	1720	36.7	p		4240	61.8	9820	10.4	
30	p		10000	28.8	1400	10.0	p		10780	57.5	1540	1.3	
40	p		21520	14.1			p		4960	62.9	600	3.3	
50	p		14280	12.6	620	48.4	p		3540	81.4	660	33.3	
60	p		13920	10.6			p		1340	91.0	500	40.0	
70					1060	20.8							
Station 4													
0		3540	0.0	4840	19.8	5920	13.2	p		1840	63.0	5560	10.4
10		8420	1.7	9660	10.1	5420	17.3	p		1560	48.7	3020	19.8
20		10700	1.7	13080	7.3	6320	19.9	1100	29.1	5680	49.3	1720	20.9
30		3540	4.5	30840	20.0	13120	8.4	1520	43.4	5100	40.8	760	21.0
40		8040	1.5	16560	49.4			5080	9.8	10740	26.6	860	53.5
50		2620		27400	15.9	321900	6.4	2680	29.1	23600	55.5	780	25.6
60		3900	1.0	26040	16.1			1360	19.1	12260	63.6	240	25.0
70						12160	7.4						

RECORDS OF OBSERVATIONS, SCRIPPS INSTITUTION OF OCEANOGRAPHY

Depth (m.)	Cruises											
	I		II		III		IV		V		VI	
	A	B	A	B	A	B	A	B	A	B	A	B
Station 5												
0	p		17200	16.3	30060	9.6	1380	44.9	520	50.0	5080	26.8
10	p		13560	17.7	27180	3.2	1580	17.7	1600	15.0	6300	38.4
20	p		5920	25.7	26720	18.6	3080	46.8	1320	16.7	6180	25.9
30	p		13600	20.9	20400	37.9	4350	32.4	1140	82.4	1400	18.6
40	p		15680	30.1			2380	32.8	3180	78.0	780	17.9
50	p		8440	9.5	4120	56.3	3740	36.9	6740	83.4	700	20.0
60	p		4720	13.6			1580	32.9	6280	85.7	760	63.2
70					520	61.5						
Station 6												
0	p				3140	80.6	580	75.9	500	92.0	14400	21.7
10	p				900	84.4	860	76.7	1280	92.2	9080	13.2
20	p				1100	74.5	860	39.5	2080	76.9	10320	12.0
30	p				800	87.5	940	23.4	17840	77.0	20720	21.8
40	p						920	60.9	13860	63.5	39320	7.6
50	p				820	90.2	860	53.5	5300	76.6	30360	7.9
60	p						2460	17.1	3060	89.5	30720	4.0
70					4040	16.8						
Station 7												
0	p				2320	49.1	3180	49.7	1360	94.1	1540	10.4
10	1670	23.4			3100	23.9	5880	27.9	960	87.5	1260	14.3
20	1410	14.2			3500	30.3	4440	28.8	1380	89.8	620	25.8
30	1800	29.4			3780	23.8	6960	23.0	2000	94.0	480	20.8
40	2020	24.8					7800	22.0	14060	87.2	660	24.2
50	1400	50.7			12640	34.8	6440	42.9	8680	85.7	160	75.0
60	280	28.6					2640	51.5	5400	91.8	100	40.0
70					200	50.0						
Station 8												
0	2820	24.8			p		280	42.9	13340	62.7	2380	15.1
10	4580	4.4			p		440	36.4	27640	69.4	2120	23.6
20	2600	12.3			p		500	20.0	27440	16.3	1480	43.2
30	3680	11.4			p		1480	12.2	7740	9.3	1740	12.6
40	4700	9.4			p		9340	32.8	1020	37.2	920	21.7
50	4500	2.2			p		2220	24.3	1200	43.3	140	85.7
60	1480	6.8					1600	40.0	700	85.7	60	
70					p							
Station 9												
0	1840	8.7			28260	33.8	28800	24.9	1880	68.1	6220	10.0
10	2740	8.0			21240	18.1	43720	17.3	2180	39.4	5480	41.6
20	3680	4.3			23040	21.1	41200	10.9	3120	26.3	1860	45.2
30	1160	0.0			14880	27.4	21120	15.5	2440	24.6	6200	19.7
40	3940	1.0					3360	25.0	380	10.5	1960	19.4
50	3880	3.6			1060	30.2	860	2.3	900	31.1	580	31.0
60	2680	2.2					1280	26.6	200	0.0	40	0.0
70					740	32.4						

Depth (m.)	Cruises											
	I		II		III		IV		V		VI	
	A	B	A	B	A	B	A	B	A	B	A	B
Station 9A												
0						p		6000	44.0		1500	17.3
10						300	26.7	13680	56.1		1420	29.6
20						p		8840	31.2		2720	4.4
30						p		11480	6.3		1980	29.3
40						8380	15.0	5160	10.1		560	7.1
50						5920	14.5	2120	37.7		120	50.0
60						440	18.2	2280	93.0		440	63.6
70												
Station 10												
0	5380	4.8			320	0.0	700	71.4	2160	31.5	84100	24.1
10	1100	9.1			920	23.9	1220	36.1	2480	13.1	72780	14.2
20	5020	12.0			1940	10.3	1380	52.2	15840	49.2	115600	16.6
30	4220	2.4			3180	21.4	1180	22.9	17960	27.2		
40	2060	24.3					860	46.5	4380	55.7	61160	7.0
50	20	0.0			540	51.8	1160	15.5	1120	19.6	3520	12.5
60	2100	36.2					900	24.4	640	65.6	2720	32.4
70					280	64.3						
Station 10A												
0							1640	45.1				
10							1560	23.1				
20							1600	15.0				
30							1260	22.2				
40							1560	32.0				
50							1320	34.7				
60							1160	32.8				
Station 11												
0					3360	10.7	120		720	38.9	16480	36.2
10					2540	19.7	p		720	75.0	8560	42.5
20					4600	12.2	p		1000	62.0	9800	27.3
30					6880	19.2	p		3880	83.0	10800	11.8
40							p		1340	74.6	12160	28.3
50					660	30.3	p		1060	49.0	1920	50.0
60							p		1660	55.4	1000	12.0
70					640	33.3						
Station 12												
0					443520	52.2	2180	4.6	1520	88.2	340	11.8
10					398640	63.0	1660	31.3	1000	94.0	440	36.4
20					124080	55.6	24320	16.8	860	76.7	p	
30					88520	62.6	3860	10.9	860	76.7	240	16.7
40							7520	10.1	320		p	
50					4160	24.5	7380	16.5	1080	81.5	p	
60							2940	18.4	40	50.0	p	
70					680	23.5						

RECORDS OF OBSERVATIONS, SCRIPPS INSTITUTION OF OCEANOGRAPHY

Depth (m.)	Cruises											
	I		II		III		IV		V		VI	
	A	B	A	B	A	B	A	B	A	B	A	B
Station 13												
0				250920	42.1	48400	3.4	62280	13.4			80
10				531000	54.2	60580	1.9	55320	7.5			p
20				183120	35.2	36320	8.4	153300	11.2			p
30				40380	33.3	24920	5.1	437220	3.7			p
40						12880	7.4	107320	8.5			p
50				7480	24.1	2200		3720	3.2			p
60						3480	8.0	3660	4.4			p
70				11680	27.4							
Station 15												
0	1220	16.4		4220	8.1	180	22.2	p				380 94.7
10	920	10.9		2740	4.4	340	0.0	p				p
20	1180	13.6		9460	21.4	2540	0.0	p				p
30	1320	18.2		13880	3.6	5020	4.0	p				p
40	1540	42.8				1700	7.1	2360	8.5			1220 36.1
50	480	0.0		1140	26.3	1660	51.8	p				p
60	340	11.8				330	81.8	640	68.8			p
70				500	16.0							
Station 16												
0	300			720	47.2	120	50.0	p				p
10	p			620	35.5	160	0.0	p				p
20	p			6100	36.4	p		p				p
30	p			27420	6.0	p		1300	26.2			p
40	p					p		p				p
50	p			1040	36.5	1680	21.4	1120	0.0			p
60	p					p		p				p
70				680	70.6							
Station 17												
0	p			660	9.1	p		p				p
10	p			380	26.7	p		p				p
20	p			1420	36.6	p		p				p
30	590	0.0		2620	9.2	p		3300	1.2			p
40	p					p		2040	4.9			p
50	p			780	15.4	p		p				p
60	p					p		p				p
70				200	40.0							
Station 18												
0	6400	1.2		3740	21.9	p		5920	9.5			290 10.3
10	13940	1.4		5760	24.0	p		16360	10.5			150 6.7
20	12060	6.0		9120	25.4	p		121200	5.7			140 0.0
30	9120	3.3		3940	30.5	p		44680	9.3			130 0.0
40	2420	5.0				p		5260	6.1			180 77.8
50	2540	12.6		660	27.3	p		41840	2.8			300 63.3
60	1000	4.0				p		7440	5.6			80 62.5
70				360	66.7							

Depth (m.)	Cruises												
	I		II		III		IV		V		VI		
	A	B	A	B	A	B	A	B	A	B	A	B	
Station 18A													
0					12360	12.0				6980	4.9	80	0.0
10					17900	12.6				6080	10.2	50	0.0
20					2460	14.6				8820	14.1	40	25.0
30					1900	4.2				7480	20.6	70	14.3
40										1080	25.9		p
50					360	16.7				12400	2.4		p
60										6820	21.1		p
70					300	20.0							
Station 19													
0	5860	14.7			1300	32.3				540	25.9	640	25.0
10	7160	19.0			820	26.8				1800	38.9	360	44.4
20	3380	7.1			1520	25.0				1140	24.6		p
30	4420	22.6			4440	25.2				1140	42.1		p
40	7080	26.8								1220	26.2		p
50	5080	20.5			240	25.0				1500	42.7		p
60	6840	7.6								400	75.0		p
70					1640	13.4							
Station 20													
0	1460	16.4			340	47.1							p
10	1500	29.3			440	40.9							p
20	1580	46.8			760	71.0							p
30	2120	6.6			400	35.0							p
40	1760	38.6											p
50	2880	19.4			600	60.0							p
60	2500	25.6											p
70					280	42.9							
Station 21													
0	760	15.8			p								p
10	460	37.0			p								p
20	p				p								p
30	p				p								p
40	p				p								p
50	p				p							2940	47.6
60	p				p							8460	31.2
70					p								
Station 22													
0	1180	26.3			p		1860	55.9					p
10	1380	13.0			p		1320	60.6					p
20	1680	20.2			p		2040	59.8					p
30	2360	28.0			p		1340	28.4					p
40	1100	22.2			p		1720	4.6					p
50	3600	12.2			p		3080	7.1					p
60	3460	8.7			p		1460	21.9					p

RECORDS OF OBSERVATIONS, SCRIPPS INSTITUTION OF OCEANOGRAPHY

Depth (m.)	Cruises											
	I		II		III		IV		V		VI	
	A	B	A	B	A	B	A	B	A	B	A	B
Station 23												
0	6900	37.7			p		1080	16.7				p
10	4480	32.1			p		240	83.3				p
20	3660	42.6			p		780	20.5				p
30	7180	33.7			p		1760	2.3				p
40	9840	34.1					300	40.0				p
50	11120	22.7			p		400	10.0				p
60	5780	31.1					300	20.0				p
70					p							
Station 24												
0	p				880	72.7	p		200	30.0		p
10	p				600	73.3	p		260	15.4		p
20	p				80	100.0	p		40	0.0		p
30	p				340	88.2	2580	36.4	380	42.1		p
40	p						840	26.2	p			p
50	p				p		p		p			p
60	p						p		p			p
70					240	16.7						
Station 25												
0	p				12140	21.9	p		p			p
10	p				9340	41.8	p		p			p
20	p				9180	34.4	p		p			p
30	p				6560	26.2	p		p			p
40	p						p		600	10.0		p
50	p		23440	27.1	960	25.0	p		820	17.1		p
60	p						p		1300	10.8		p
70					400	50.0						
Station 27												
0	p		9840	12.2	5400	37.0	p		2420	39.7	12020	13.5
10	p		6320	36.7	2820	51.1	p		1460	20.5	10720	21.8
20	p		5000	21.6	9160	22.0	p		1200	45.0	20540	26.3
30	p		2840	42.2	1020	68.6	340	11.8	1200	30.0	19000	25.9
40	p		960	20.8			400	20.0	4500	48.0	5060	19.4
50	p		5520	57.2	960	62.5	p		3880	40.2	6660	32.1
60	p		920	4.3			p		2580	25.6	2440	54.9
70					560	42.9						
Station 27A												
0			182320	10.1	320	25.0	780	87.2	2020	60.4	3420	75.4
10			110500	12.0	140	57.1	180	88.9	3960	32.3	1460	64.4
20			53320	8.6	p		700	68.6	2560	39.1	1500	45.3
30			97920	11.2	p		1420	85.9	3560	26.4	1640	73.2
40			173200	9.6			p		2420	8.3	2160	29.6
50			166400	9.2	1280	35.9	p		4880	14.8	2540	73.2
60			23520	21.8			p		2160	30.6	1960	61.2
70					140	42.9						

Depth (m.)	Cruises											
	I		II		III		IV		V		VI	
	A	B	A	B	A	B	A	B	A	B	A	B
Station 28												
0	2720	24.3			520	57.7	420	85.7	7620	12.3	2780	30.9
10	4820	22.0			240	8.3	1400	91.4	8700	25.1	1480	45.9
20	940	19.1			420	81.0	320	43.8	6900	32.5	3660	38.2
30	1260	22.2			200	30.0	1440	16.7	10360	26.2	600	40.0
40	2100	12.4					640	43.8	201560	6.0	740	24.3
50	1900	9.5			2520	21.4	460	39.1	177780	2.3	240	33.3
60	1320	18.2					320	50.0	6640	19.6	680	61.8
70					160	62.5						
Station 28A												
0	7720	13.7	164800	12.5	320	12.5	540	77.8	3940	33.0	5540	23.5
10	18540	12.9	293760	9.1	440	40.9	700	94.3	2800	50.7	11500	38.3
20	15680	21.9	278560	6.1	520	34.6	860	86.0	6120	31.0	9320	41.6
30	19880	25.2	355000	8.0	120	16.7	1760	6.8	20320	17.7	2370	64.1
40	24000	22.7	596280	9.6			460	17.4	15000	5.3	9060	42.4
50	27380	15.9	860560	9.3	5020	16.3	580	65.5	11160	18.3	3620	20.4
60	25200	24.6	220200	17.5			1420	18.3	1480	27.0	2240	52.7
70					1600	66.2						
75			181600	20.3								
Station 29												
0	1580	21.5	11560	40.5	100	60.0	p		64960	42.6	2680	13.4
10	2560	44.5	8000	52.6	60	66.7	p		90720	41.0	1300	44.6
20	2480	34.7	22800	27.2	200	50.0	p		73200	21.3	1760	17.0
30	3400	35.3	26700	46.8	1360	5.9	p		41480	16.5	3220	24.8
40	2000	31.0	15520	23.7			740	24.3	15720	15.3	2620	37.4
50	840	23.8	47380	25.7	5560	14.4	1300	12.3	10600	10.6	560	35.7
60	2660	3.8	65640	55.9			580	10.3	1840	10.9	360	50.0
70					340	11.8						
Station 30												
0	13920	23.3	4880	37.7	100	20.0	960	56.2	128600	36.7	6740	23.1
10	13920	42.2	6960	29.9	100	60.0	860	37.2	119280	20.9	2140	39.2
20	22720	54.4	10280	27.2	160	50.0	1240	91.9	195360	27.4	5620	27.0
30	17900	28.9	8680	5.1	500	88.0	900	64.4	38520	15.0	7400	23.0
40	32840	38.4	37200	20.0			660	57.6	12280	20.8	4860	12.3
50	26600	16.1	28920	50.1	660	24.2	1880	23.4	5720	16.1	4560	11.4
60	5000	12.8	15680	61.0			1700	31.8	1280	34.4	1020	58.8
70					360	100.0						
Station 31												
0	10840	14.8	2320	19.0	p		p		1420	22.5	800	67.5
10	8000	31.0	160	25.0	p		p		2280	57.0	1400	51.4
20	10640	42.1	320	50.0	p		p		1560	29.5	2940	29.9
30	8160	25.0	780	12.8	p		p		4000	6.5	3420	70.8
40	13680	19.9	3280	32.9	900	17.8	p		880	18.2	2280	65.8
50	14560	38.5	6540	30.6	p		p		1980	56.6	1500	29.3
60	10280	16.3	11620	35.6	p		p		660	57.6	600	66.7

