

1902

THE TEXTILE  
WORLD



OF THE  
TEXTILE INDUSTRIES

ALSO THE  
YARN TRADE INDEX

TABLE OF CONTENTS, PAGE 39

BUYER'S INDEX, PAGE 43

GUILD & LORD, PUBLISHERS  
BOSTON, MASS.





1902

THE TEXTILE  
WORLD

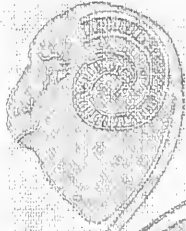

OF THE  
TEXTILE INDUSTRIES

ALSO THE  
YARN TRADE INDEX

TABLE OF CONTENTS, PAGE 38  
BUYER'S INDEX, PAGE 43

GUILD & LORD, PUBLISHERS  
BOSTON, MASS.

# LIBRARY



TS 1312  
OF 1  
1902

If You are not using  
The **Berry Wheel**

you are not getting the best results  
in DRYING, VENTILATING or in  
ANY OTHER OPERATION where a  
fan is required.

This statement is based on the  
experience of sixteen years.

Write to . . .

**A. HUN BERRY,**

23 W. First St.,       =       =       Boston, Mass.

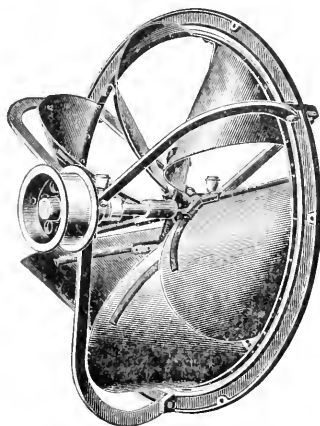

This is The Berry Wheel.

71581

---

# LOWELL MACHINE SHOP,

LOWELL, MASS.,

Builders of

# COTTON MACHINERY

OF EVERY DESCRIPTION.

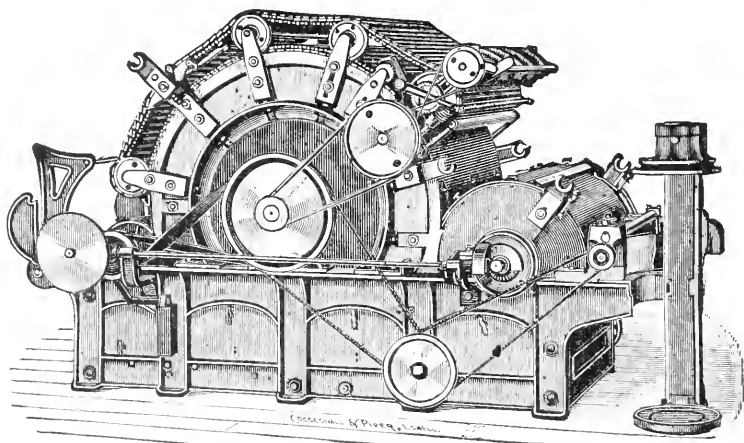

Revolving Flat Cards,                  Railway Heads,  
 Ring Spinning Frames,                  Fly Frames,  
 Drawing Frames,                  Spoolers, Warpers,  
    Slashers,                                  Looms.

---

## Worsted Machinery.

---

ILLUSTRATED CATALOGUES SENT ON APPLICATION.

## *Draper Company Products.*

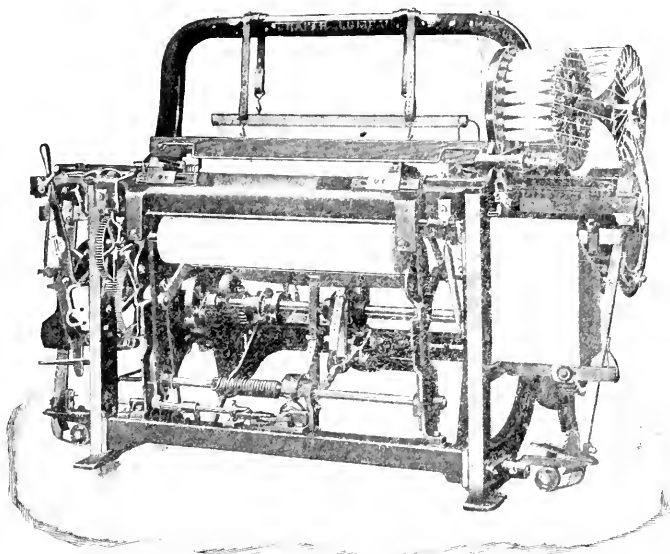

### **Our Latest Northrop Loom.**

**W**E begin to feel quite independent in our loom trade, as the results of experience have proven that our position is absolutely unassailable. A few facts speak for themselves :

80,000 looms sold or changed over to date.

Weavers earning more money at one-half former price per cut.  
Good weavers running 24 to 32 print looms and 20-3 harness looms.

Gingham weavers running 6 looms with warp-stop motion.

In one large print mill the AVERAGE number of looms per weaver is eighteen.

We have practically doubled the size and efficiency of our plant in the past two years.

Separate corporations building these looms in Canada, Germany, France, Switzerland and Austria.

You can feel assured that merit is recognized when the copyist appears—but you don't want a copy.

## *Draper Company Products.*

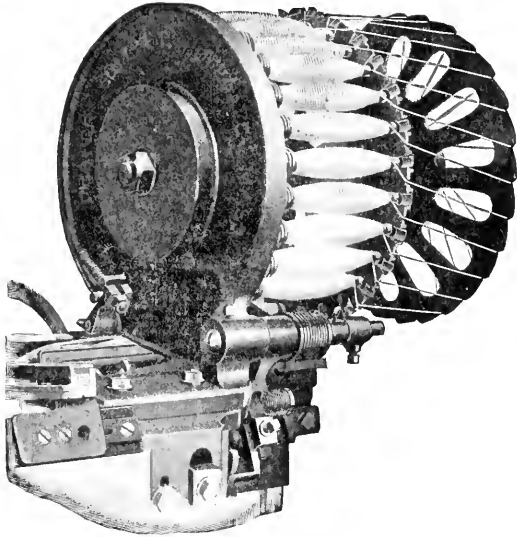

DETAIL OF HOPPER MECHANISM.

We used to claim that weavers could attend Northrop Looms in the proportion of two to one common. The users are finding this prediction far too moderate as they often run three to four times their former limit.

In several mills, weavers are paid LESS than one-half the former price for weaving cloth per cut, and yet make HIGHER wages than when running common looms.

A mill that cannot appreciate that statement simply cannot appreciate the tale told by concrete figures. Those who attempt to sell cloth handicapped by an extra cost of from one cent per pound upward, can cling to their obsolete common looms while their more enterprising neighbors glean the profits.



## *Draper Company Products.*

We have by no means stopped manufacturing other Cotton Machinery simply because our loom has become such an important factor in our business. We not only continue to make and sell

Twisters,  
 Warpers,  
 Spoolers,  
 Reels,  
 Balling Machines,  
 Spindles,  
 Temples,  
 Separators,  
 Spinning Rings,  
 Etc., Etc.

But we continue to improve them. We have modified the detail of that most excellent spindle—**The Draper No. 2**—until after repeated tests and trials we find nothing seemingly capable of further improvement for present use.

Our rings are now made by improved process, and are better than ever.

We have recent improvements in Warpers of great importance.

We shall endeavor to keep the trade duly informed of new features by circulars.

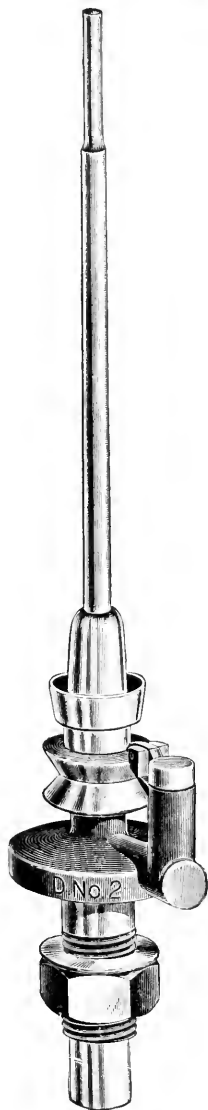

Draper No. 2 Spindle.

**DRAPER COMPANY,**  
*Hopedale, Mass.*

---

# MASON MACHINE WORKS,

## TAUNTON, MASS.

# COTTON MACHINERY

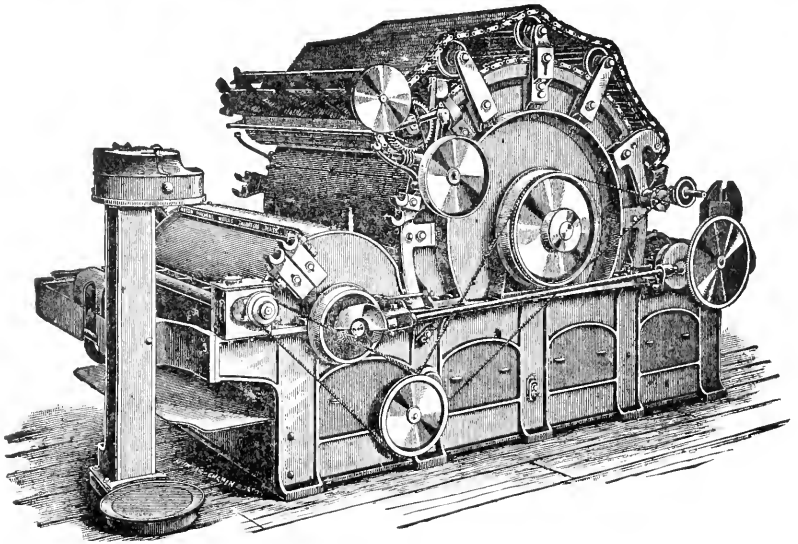

Cards, Combers, Lappers, Railway  
Heads, Drawing Frames, Spin-  
ning Frames, Mules and  
Looms,

INCLUDING

## Plain and Fancy Silk Looms.

Southern Office, Charlotte, N. C.

# Kilburn, Lincoln & Co.,

FALL RIVER, MASS.

## LOOMS

For Cotton and Silk Weaving.

ALSO SHAFTING, PULLEYS AND HANGERS.

*The Kilburn, Lincoln & Co. High-Speed Loom.*

THERE are over 30,000 "High-Speed Looms" manufactured by Kilburn, Lincoln & Co. in successful operation in the city of Fall River alone, and many thousands more in other parts of New England and the South.

The light-running qualities of this loom and the consequent great saving in power, commend it to manufacturers. On account of the light-running feature, combined with strength, our loom is especially adapted to be run at High Speed. At the Seaconnet Mills, Fall River, 928 of these looms were in operation for a number of years at 204 picks per minute, turning out, in 301 days of 10 hours each, 14,329,219 yards 64x64 goods, a daily average of 51 3-10 yards per loom.

Of the other Fall River mills using our looms may be mentioned the King Philip, where 3,000 are in operation on the finest grades of cotton cloth. The Hargraves and Parker Mills, also, are fitted with our "New High-Speed Loom," manufacturing fancy goods, some of which are the finest produced in the country. The new Arkwright Mill is operating 1,350 of our HEAVY PATTERN Looms.

We claim that the mills producing the largest quantities of goods per day, as well as those producing the finest quality of goods, are running our looms.

*We are building our High-Speed Looms with the Northrop continuous filling and warp-stop motions attached.*

REPRESENTED IN THE SOUTH BY....

**O. A. ROBBINS,**

CHARLOTTE, N. C.

# C. E. RILEY & CO.

281-285 CONGRESS STREET, BOSTON, MASS.

BUILDERS AND IMPORTERS OF

COTTON WOOLEN WORSTED

## MACHINERY

CARD CLOTHING. EGYPTIAN COTTON.

AGENTS FOR

**Howard & Bullough, Ltd.**, Revolving Flat Cards, Electric Stop-Motion Drawing Frames, New Pattern Slubbing, Intermediate, Roving and Jack Frames, Warpers and Slashers.

**Richard Threlfall**, Patent Self-Acting Mules for Spinning Medium and Fine Counts.

**Hall & Stells**, Preparing and Finishing Gills, Drawing and Roving Boxes, Spinning and Twisting Frames.

**Construction de Machines Ci-Devant, F. J. Grun**, French System of Worsted Machinery, etc.

**Hoyle & Preston**, Noble Combs, Lister Combs, Back Washing Machines, Blast Hot Air Wool Drying Machines, Scouring Machines.

**James Tomlinson**, Cotton Waste, Mungo, Shoddy and Rag Machinery, Engine Cleaning Waste Machines, Hard Waste Breaking Machines.

**John Haigh & Sons**, Willows, Fearnoughts, Woolen and Worsted Cards, Bank Blamire, Scotch and Hopper Feeds, Balling Heads, etc.

**Thos. Broadbent & Sons**, Patent Suspended Direct Steam Driven Hydro-Extractors. Over 3000 at Work. Machines kept in stock in Boston.

**John Whiteley & Sons**, Card Clothing, Hardened and Tempered Steel, Needle-pointed or Plough Ground.

**L. M. Tetlow & Sons**, Card Clothing for Woolen and Worsted Cards.

**John Greenhalgh & Sons**, Willows for Opening and Cleaning Cotton Waste, Fly, Strips, Picker Droppings, Flocks and Curled Material.

SPINDLES, FLYERS, FLUTED AND SHELL ROLLS,  
EMERY FILLET, ETC.

## EGYPTIAN COTTON

(PEEL & CO.)

HOWARD & BULLOUGH  
 AMERICAN MACHINE CO., LTD.  
 PAWTUCKET, R. I.

# COTTON MACHINERY

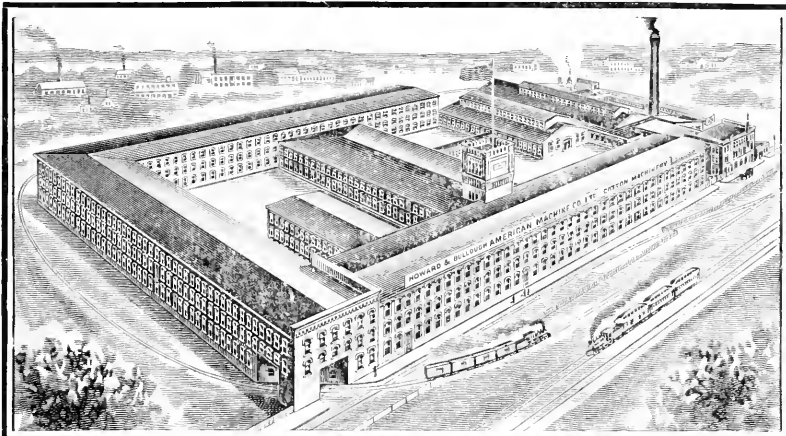

BOSTON OFFICE  
 281-285 Congress St.

SOUTHERN OFFICE  
 814-815 Empire Bldg.  
 Atlanta, Ga.



WE INVITE YOUR INVESTIGATION  
AND COMPARISON

Bale Breakers	Intermediate Frames
Feeders	Roving Frames
Self Feeding Openers	Jack Frames
Breaker Intermediate and	Improved Spinning and
Finisher Lappers	Twisting Frames
Revolving Flat Cards	Cone Winders
Drawing Frames	Warpers
Slubbing Frames	Slashers

HETHERINGTON'S  
**Cotton Machinery**

Was never so popular in the United States  
 as now. It is built with  
**ENGLISH THOROUGHNESS**  
 and kept up to date with  
**AMERICAN ALERTNESS.**

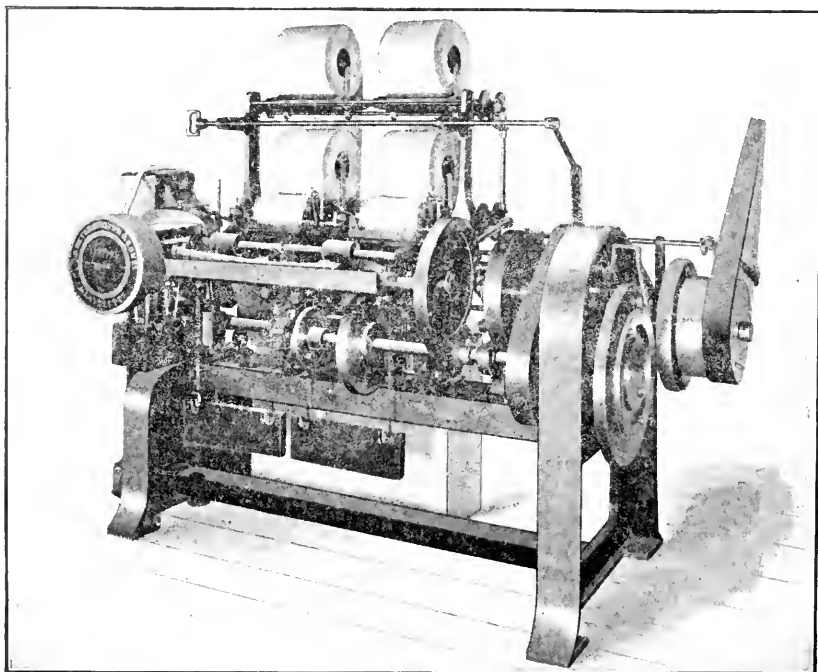

**THE NASMITH COTTON COMBER**

Is the latest and best in the way of simplicity,  
 larger product, better work.

BUILDERS OF ALL KINDS OF

**Machinery for Preparing, Spinning, Doubling Cottons,  
 Cotton Waste, Woolens, Etc.**

Sole Importer for United States and Canada,

**STEPHEN C. LOWE, Boston, Mass.**

41-42 Brewer Building.

186 Devonshire Street.

J. S. COTHMAN, Charlotte, N. C., Southern Agent.



---

# COTTON MACHINERY.

---

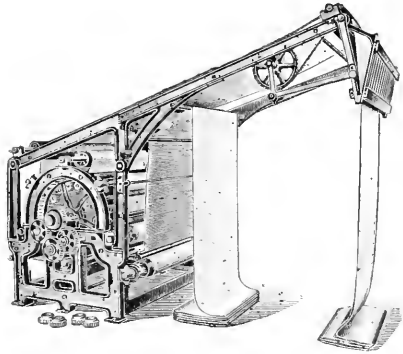

COTTON NAPPER.

16 Workers.  
Six Contacts.

—  
More production than any  
other Napper yet built.

**WE** make all kinds of  
Cotton Shears.  
Let us talk with you.

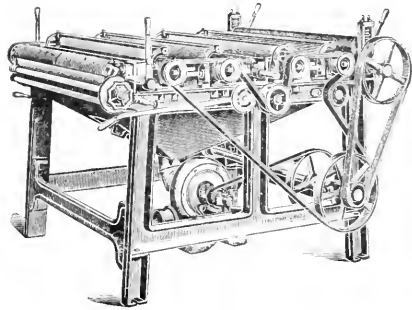

COTTON SHEAR.

---

## Parks & Woolson Machine Co.,

Springfield, Vermont, U. S. A.

# HUNTER'S IMPROVED CLOTH WASHER

For Four, Six and Eight Strings of Goods.

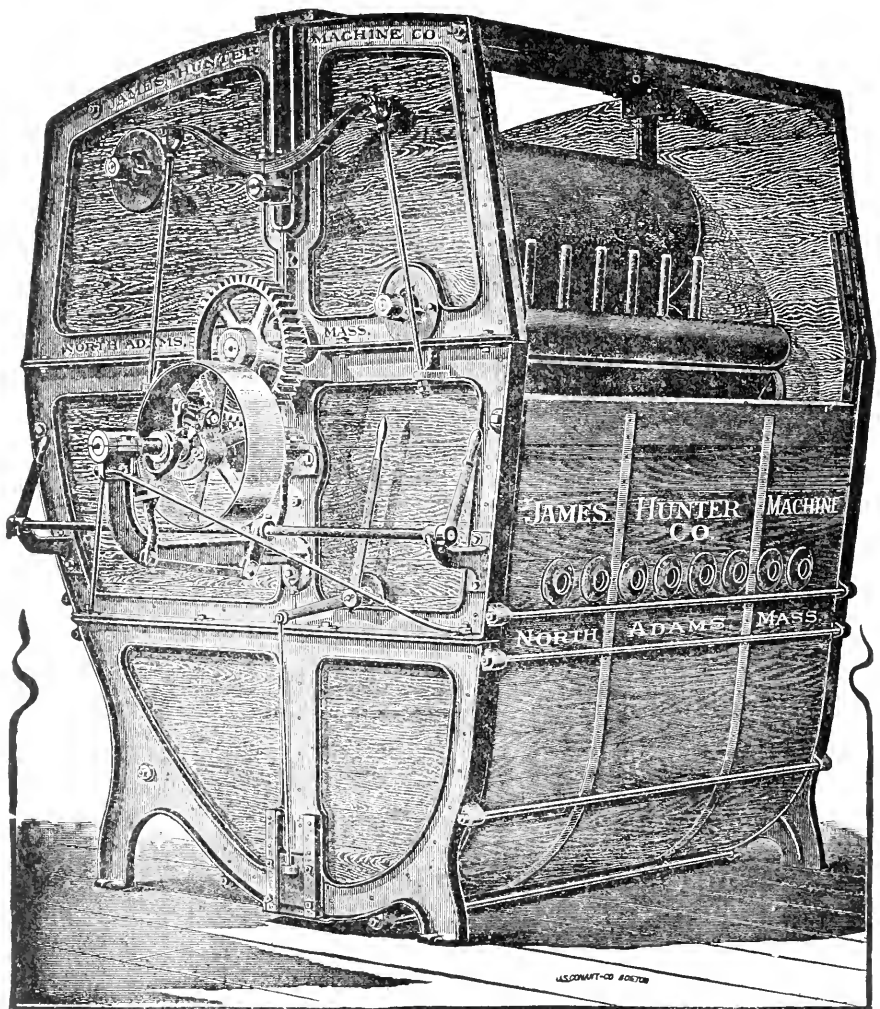

**Power transmitted by means of a Friction Pulley.**

**No Shifting of Belt to start and stop the machine.**

**Less power required than for any other Washer of equal capacity.**

**All Main Bearings are adjustable. All Bearings are on the outside of frame.**

**No dripping of Oil on the Goods, or in the Wash Box.**

*Also Combination Washer and Fuller for Knit Goods in the String.*

Write for further particulars and prices

## **JAMES HUNTER MACHINE CO.,**

**North Adams, Mass.**

**Boston Office, Room 67, Mason Building, 70 Kilby St.**

**Long Distance Telephone, 2954.**

# LATEST IMPROVED CLOTH WASHER

For Four, Six and Eight Strings of Goods.  
Greatest Economy in Power and Labor.

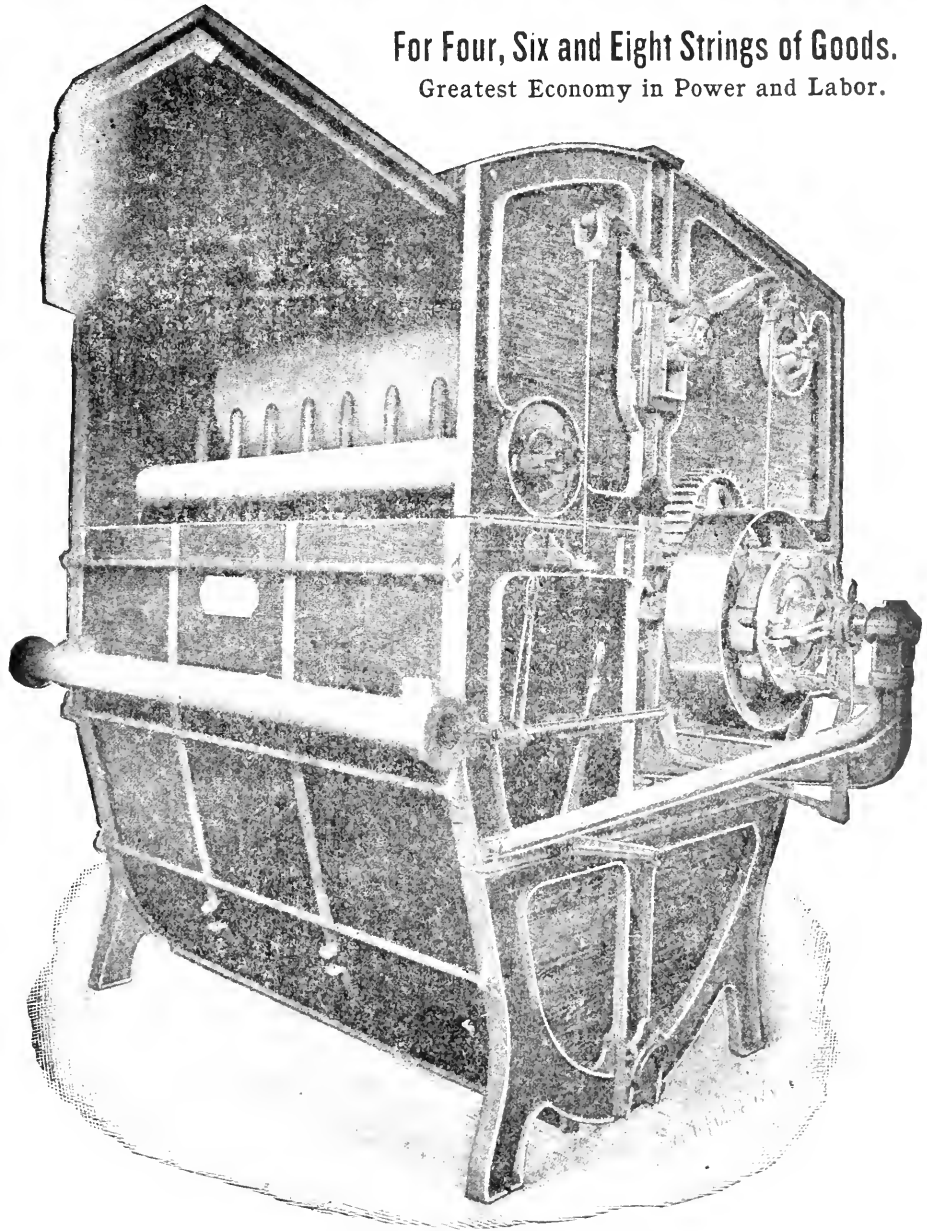

## Unequaled for Capacity and Rapid Washing

All Kinds of Heavy and Light Goods are Desired.

Attachment for Washing and Fulling Knit Goods in the String.

**RODNEY HUNT MACHINE CO.,**

Main Office and Works, ORANGE, MASS.

Boston Office, 70 KILBY ST., Room 87.

Long Distance Telephone. Send for New Illustrated Catalogue. Telephone No. 1522.

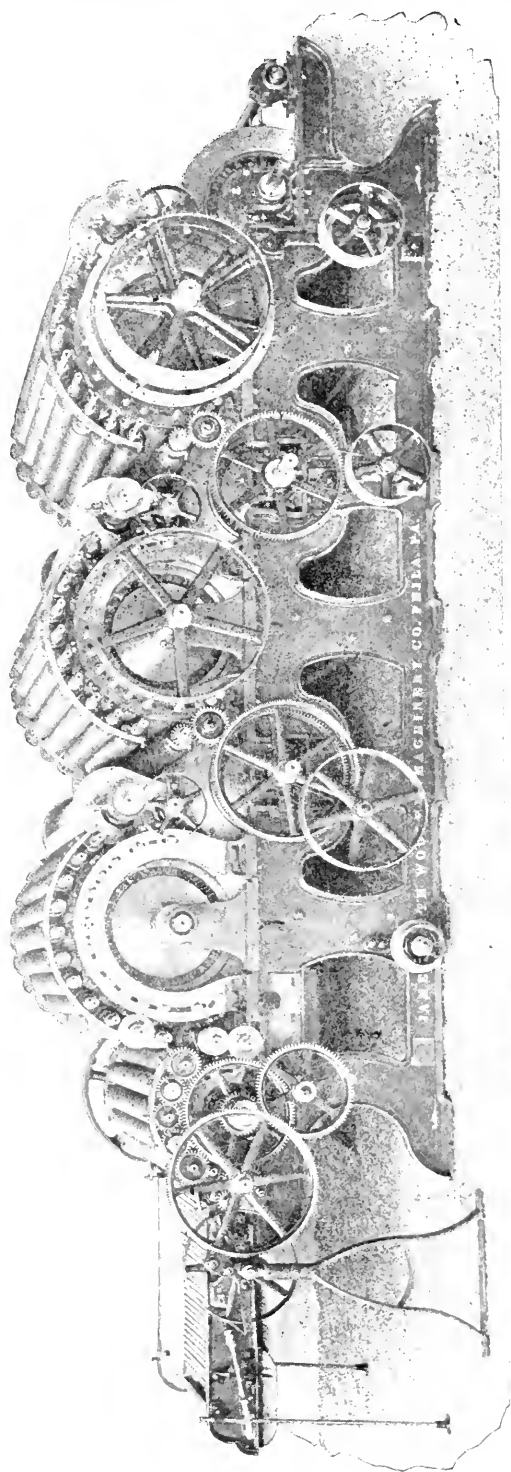

## SMITH'S IMPROVED GARNETT MACHINE.

### GARNETT MACHINES.

Garnett Machines for opening Worsted Thread Waste, cotton cop yarns, re working hosiery clips and waste, and shoddy work in general; Garnett Pickers; Metallic Breakers of every description; Feed Rolls, Lickerins and Burring machines; Re-clothing, and every character of Metallic Work.

### SELF FEEDERS.

Improved Automatic Self-weighing Feeders for First Breaker Cards and Garnetts; also Self-feeders for Wool and Mixing Pickers, Burr Pickers; Wool Washers, etc.; Apperly Feeders and Blamire Lap Feeders.

ENTIRE MACHINERY EQUIPMENT FOR THE MANUFACTURE OF COTTON BATTING

for Commercial Batts, Comformers, Mattresses, Carpet Lining, Stair Pads, etc.

### CARDS.

Cards of every description, special attention being called to our Twentieth Century Card.

### MULES.

Self acting,—of both English and American pattern.

### PICKERS.

Wool, Burr and Rag Pickers, and Lumpers.

### WILLOWS.

Cone Willows, Square Willows and Dusters.

RING TWISTERS; AUTOMATIC BLOCK SPOOLERS; WARP SPOOLER; AND DRESSERS. WOOL WASHING AND SCOURING MACHINERY. GRINDERS FOR CARDS AND METALLIC WORK IN GENERAL.

Complete WOOLEN and WORSTED Mill equipment up to and including spinning.

### POWER TRANSMISSION.

Power Transmission material of every character; Friction Clutches; Shafting; Hangers; Pulleys, etc.

### SUPPLIES.

Mill Mining, Engineer and Railroad Supplies; Steam and Hydraulic Packings. Designer and building of Special machinery of every character.

**JAMES SMITH WOOLEN MACHINERY CO.,**

OFFICE AND WORKS, 411-421 RACE STREET,

PHILADELPHIA.

# Woolen Machinery.

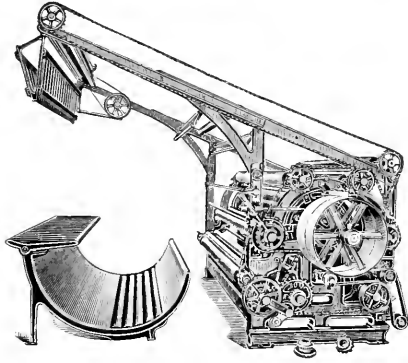

WOOLEN NAPPER.

*16 Workers.*

*5 Contacts.*

Energies, Contacts and Cloth  
Feed all adjustable.

**The Only Napper.**

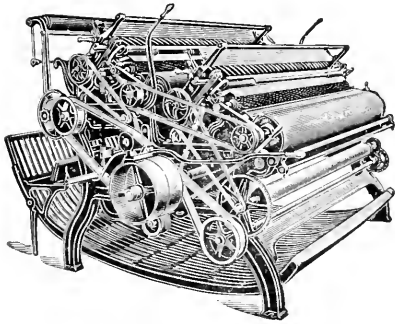

DOUBLE SHEAR.

**D**OUBLES your produc-  
tion and pays for itself  
in two years. You can't af-  
ford to run single shears.

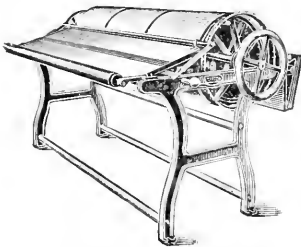

A W C MEASURER.

**S**UPERSEDES all other  
systems of mill measur-  
ing.

**Parks & Woolson Machine Co.,**

Springfield, Vermont, U. S. A.

---

# M. A. FURBUSH & SON MACHINE CO.

## WOOLEN

CARDS

CARD GRINDERS

PICKERS

MULES

TWISTERS

WARPERS

DRESSERS

SPOOLERS

## MACHINERY

TWELFTH AND MARKET STS., CAMDEN, N. J.

Philadelphia Office, 428 Bourse

---

## NAPPING MACHINES

Columbia

Napping

**MACHINE CO.**

**ALBERT BIRCH, Treasurer,**  
SOMERVILLE, MASS.

Combining the latest American,  
French and English improvements.

*Send for prices.*

Samples napped and machines on exhibition.

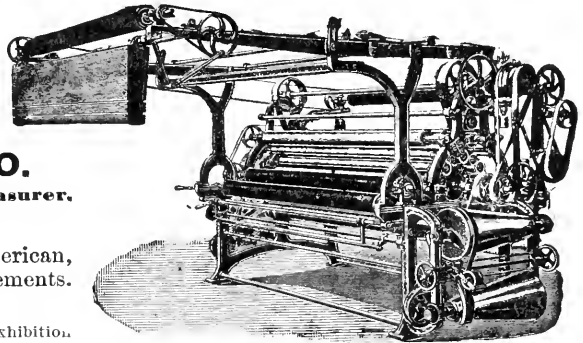

---

## CURTIS & MARBLE MACHINE CO.,

MANUFACTURERS OF

Wool Burring, Picking and Mixing Machinery.

## Cloth Finishing Machinery

FOR COTTON, WOOLEN, WORSTEDS, PLUSH GOODS, ETC.

SHEARING MACHINES A SPECIALTY.

New Works, 72 Cambridge St., near Webster Sq.

**WORCESTER, MASS.**



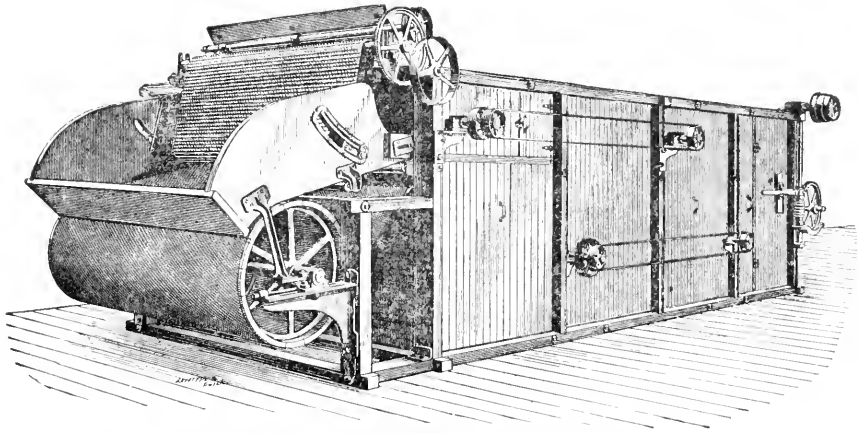

AUTOMATIC COTTON STOCK DRYER.

## “Cyclone” Dryers

For Wool, Cotton Stock, Yarn,  
Underwear and Stockings,  
Carbonizers for Wool, Rags  
and Noils.

BREASTS, BURRING MA-  
CHINES, FEED ROLLS,  
LICKERS-IN . . . . .

## Garnett Machines,

### “CYCLONE” FANS.

Philadelphia Textile Machinery Co., Philadelphia, Pa.

# GENERAL ELECTRIC COMPANY

DESIGNS AND INSTALLS

## ELECTRIC POWER and LIGHTING PLANTS,

FOR ALL CLASSES OF

## TEXTILE MILLS,

45,000 Horse Power in use or under contract.

### THE ADVANTAGES OF ELECTRIC DRIVE ARE:

Saving of the cost of Belt Towers and of Investment for future Extension.

Saving in cost of shafting: increased light due to the absence of belts.

Fewer faults in product, due to absolute uniformity in speed.

More product per horse power at the engine.

Subdivision of power— independent operation of each department.

General Office; Schenectady, N. Y.

NEW YORK, 44 Broad Street.  
BOSTON, 200 Summer Street.

PHILADELPHIA, 214 So. Eleventh St  
ATLANTA, Empire Building.

# "HURRICANE" DRYERS

— FOR —

WOOL, COTTON STOCK, YARN,  
STOCKINGS, UNDERWEAR, &c.

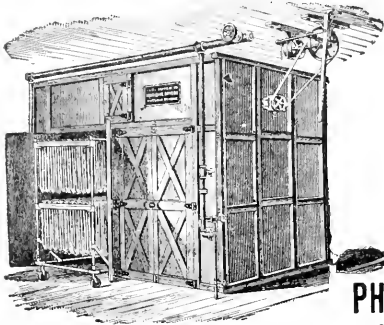

TRUCK YARN DRYER.

COMPLETE PLANTS FOR  
**CARBONIZING**  
Wool, Moils, Rags and Cloth.

YARN SCOURING MACHINES.  
"HURRICANE" FANS.

Write for Booklets.

**PHILADELPHIA DRYING MACHINERY CO.,**  
6721 GERMANTOWN AVE., PHILADELPHIA, PA.

ESTABLISHED 1887.

## HOMER F. LIVERMORE

**HIGH GRADE**

Steel, Malleable and Grey Iron,  
Bronze, Brass and Aluminum

### **CASTINGS.**

Repair Parts for Mill Machinery a Specialty.

OUR PRICES THE LOWEST IF QUALITY IS A FACTOR.

**86 PEARL STREET.**

Long Distance Telephone.

**BOSTON.**

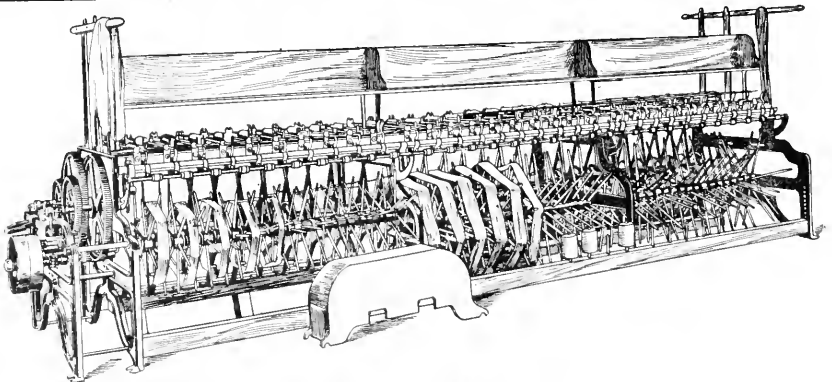

**1901 PATTERN**

## Patent Linen Winder for Shuttle Bobbins

With Patent Variable Motion.

Winds from below and from 90° skeins direct to shuttle bobbins. Impossible to wind yarn any harder. Runs at high speed, gives large production. Cleaners attached, to rub off dross and loose fibres from the yarn.

We also build a line of SPOOLING, WINDING, WARPING and BEAMING MACHINERY. Write for particulars.

**JACOB K. ALTEMUS,**

Successor to W. W. Altemus & Son,

2818 No. 4th Street,

Philadelphia, Pa.

WOOL WASHERS

WOOL DRYERS

WOOL DUSTERS

AUTOMATIC FEEDERS

WASTE DUSTERS

CRUSH ROLL MACHINES

BOX WILLOWS

RAG DRYERS

COTTON STOCK DRYERS

AUTOMATIC DYEING MACHINES

YARN DRYERS

WASTE CARDS

# 50 Years Development

—IN—

## Wool Washing.

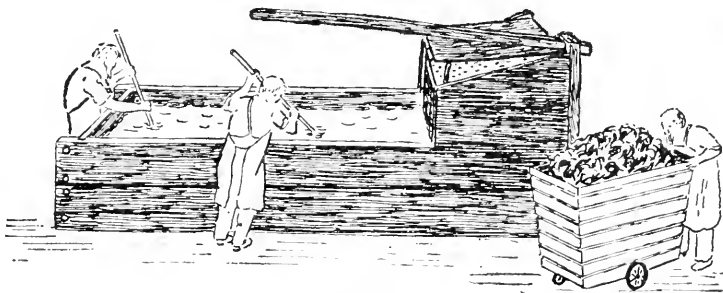

1852.

500 LBS. OF WOOL PER DAY.

The method of wool washing that prevailed when the Sargents entered the field.

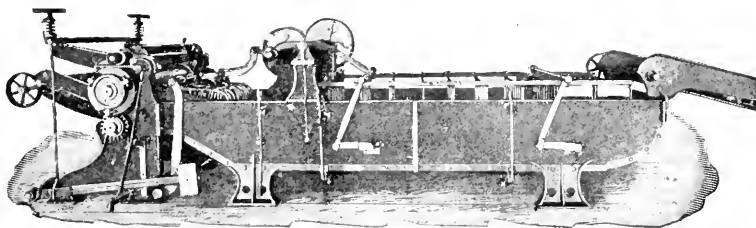

1902.

20,000 LBS. OF WOOL (60% SHRINKAGE) IN 10 HOURS.

The Parallel Rake Washer. A product of the 20th century.

“ The wool coming from this machine, similar to the natural condition of the fleece ; it is neither rolled, twisted or ropy, consequently it is very easily carded, and perfectly clean. The main point of advantage in your parallel rake is the very small noil which we have made since we put in these machines.—*Extract from a letter of a prominent Worsted Yarn Company.*”

**G. G. SARGENT'S SONS,  
Graniteville, Mass.**

FULL CARBONIZING PLANTS

CARBONIZING DUSTERS

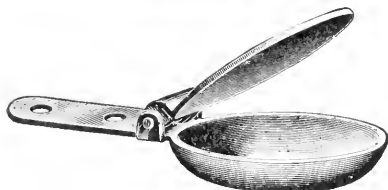
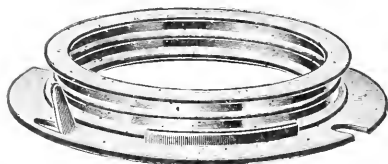
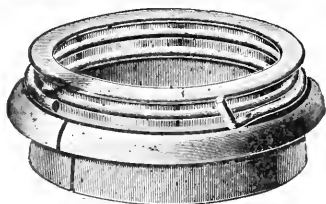

# Mill Men Feel Safe

IN BUYING OUR

## SPINNING RINGS.

They Represent 30 Years Experience in Ring Making. Constant effort for something better. Special study of stock to learn what composition produces best rings. Aim to lower prices while improving the rings.

Our Nickered Steel plate Traveler Cup is the best and most popular Traveler Cup ever produced.

There are but few modern mills that are not equipped with our U. S. Standard Traveler Cleaner.

We make our products worth the money.

WHITINSVILLE SPINNING RING CO.,  
Whitinsville, Mass., U. S. A.

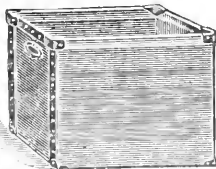

Send for Price  
List to

# FIBRE

Specialties  
for  
Textile  
Mills.

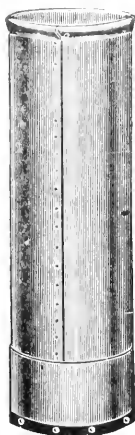
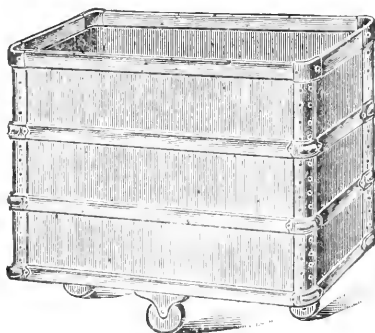

# Spaulding= Perkins Company,

No. Rochester,  
New Hampshire.

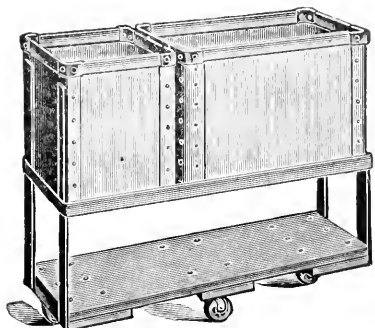

# PAPER TUBES

ALL SIZES

ALL COLORS

ALL SHAPES

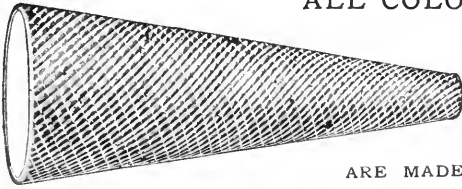

For Textile and Manufacturing  
Purposes

ARE MADE BY

## The Pairpoint Corporation.

PAPER DEPARTMENT.

FORMERLY THE NEW BEDFORD PAPER CO.

PAPER MILL AND TUBE FACTORY,

**NEW BEDFORD, MASS.**

Write for Samples and Prices.

ANDREW G. PIERCE, JR.,  
PRESIDENT.

CLARENCE A. COOK,  
TREASURER.

THOS. A. TRIPP,  
GEN. MANAGER.

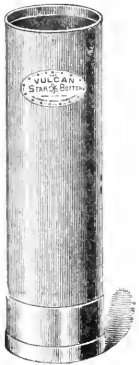

## VULCAN FIBRE ROVING CAN.

BODY—Vulcanized Fibre. SIDE SEAM—Riveted with Patented Clinched Rivets. RINGS—Tinned Steel, Brazed Joints, Curled Edges. BOTTOM—IXXX. Tin Star Corrugation: Fastened without the use of nails or screws, will not crack, warp or shrink and cannot come out. FINISH—Coated inside and out with moisture proof coating, handsome and smooth. WEIGHT—About one half pound per inch diameter. SIZE—All cans to an exact size, perfectly round and true. DURABILITY—Superior to any other can.

ALSO MANUFACTURERS OF HILL'S IXXX TIN AND GALVANIZED IRON DYE HOUSE CAN.

**JAMES HILL M'F'G. CO.,**

PROVIDENCE, - - - - - R. I.

## WHITIN MACHINE WORKS,

BUILDERS OF

# COTTON MACHINERY,

**WHITINSVILLE, MASS.**

# Emmons Loom Harness Co.,

## Loom Harness and Reeds.

*T. A. EMMONS,*

*- Treasurer and Manager.*

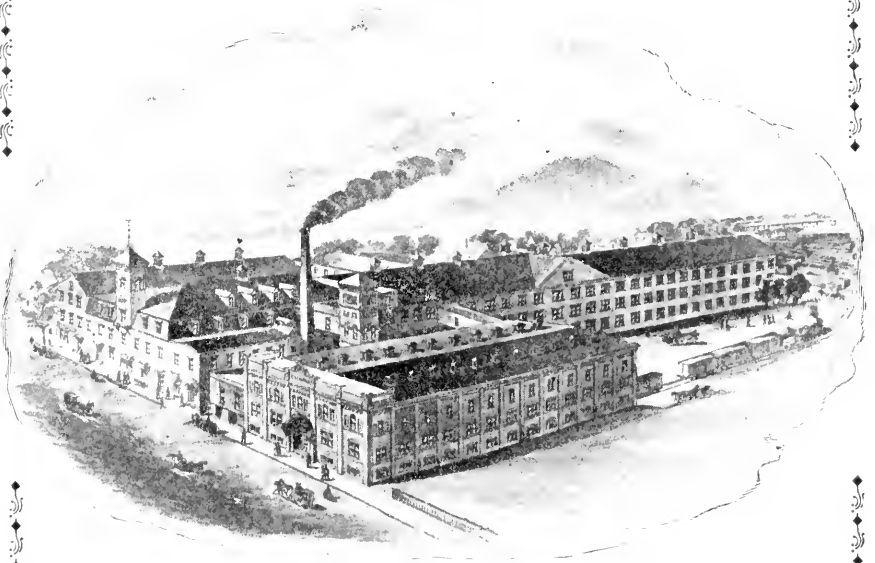

**COTTON HARNESS** for all kinds of Plain and Fancy Weaves in Cotton, Linen and Silk Goods.

**MAIL HARNESS** for Duck, Worsted, Silk and Woolen Goods.

**SELVEDGE HARNESS** 18 to 25 inches deep, for Weaving Tape Selvedges.

**REEDS** for Cotton, Woolen, Silk and Duck.

**SLASHER AND STRIKING COMBS.**

**WARPER AND LEICE REEDS.**

**JACQUARD HEDDLES.**

**BEAMER AND DRESSER HECKS.**

**MENDING EYES AND TWINE.**

*Our Baked English Harness for Silk Weaving  
are Guaranteed to be the Best in the World. .*

**LAWRENCE, MASS.**



# WILLIAM CRABB & CO.,

NEWARK, N. J.

Manufacturers of the following goods :

Bagging Loom Reeds	Fallers	Porcupines
Cotton Banding	Feed Rollers in Brass Shells, Rivets	
Card Clothing in Leather	Gill Brass	Rotary Gills
Card Clothing in Wood	Gills and Gill Bars	Spreader Pins
Card Pins	Hackles	Steel Springs
Circles	Hackle Pins	Steel Wire
Comber Needles	Jennie Pins	Teathering Pins
Comb Pins	Needle Pointed Goods	Waste Machine Clothing & Teeth
Drawing Frame Pins	Picker Teeth	Weavers Combs

ALSO GENERAL MILL SUPPLIES.

NORTH CHELMSFORD SUPPLY CO.,

North Chelmsford, Mass.

MANUFACTURERS OF

## Oak = Tanned Leather Belting,

Roll Covering, Lace Leather, Leather Aprons, Comb and Machine Brushes, Comb Circles and Fallers. Circles and Fallers Repaired. Oil Cans and Mill Supplies of all kinds. Drawing and Spinning Rolls Covered and Bossed.

SPECIAL ATTENTION IS GIVEN TO REPAIRING.

**First-Class Work Guaranteed.**

SELLING AGENTS FOR TURNER'S PATENT ROLL COVERING MACHINE.

J. S. TURNER, Manager.

HENRY WOODS, Treasurer.

DAVID G. RODGERS,

## General Mill Supplies,

Beaming, Wrapping, Buff and White and Finishing Paper, Cylinder, Machine, Engine, Spindle and Neatsfoot Oil, Shuttle Springs, Glass Rings, etc.

## Hoyt's Leather Belting.

169-171 VAN HOUTEN ST., PATERSON, N. J.

== MODERATE PRICED ==

## Gear Cutting Machine

Especially adapted for use in Repair Shops. Now in use in **Three Hundred** representative mills, including **Twenty-four** in Fall River, Mass. On application, we shall be glad to submit full particulars, prices, and photographs of the latest improvements. Send for our **1900 Pamphlet**.

THE D. E. WHITON MACHINE CO.,

19 Oak Street, New London, Conn.

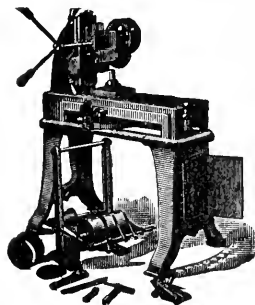

Established 1849

J. F. MASON, Pres.

MASS. CORPORATION.

A. G. MASON, Sec.

Incorporated 1900

S. R. MASON, Treas.

# MASON BRUSH WORKS

Manufacturers and Repairers of all kinds of



COTTON COMBER ROLL.

## MILL BRUSHES

Worcester, Mass.

*(Write for Catalogue.)*

FRED S. COBURN,

## GENERAL MILL FURNISHER,

Steam and Water Pipe and Plumbing in Mills.

*White Hickory Picker Sticks a Specialty.*

243 Main St.,

WOONSOCKET, R. I.

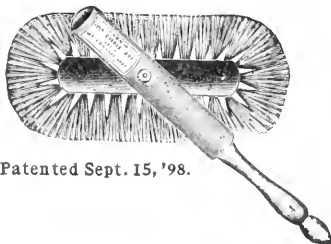
Long Distance  
Telephone 104-2.

Patented Sept. 15, '98.

Patent adds 100 per cent. to Utility.

Window Washers, Floor Sweepers,  
and Counter Brushes.

## Mill Work a Specialty.

CHARLES H. GRANT, Manager.

RHODE ISLAND BRUSH CO.,

SOLE OWNERS AND MANUFACTURERS OF

## THE BAXTER REVOLVING BRUSH,

FACTORY, 50 DANIEL AVE., PROVIDENCE, R. I.

Post Office Address, Olneyville Station.

## American Card Clothing Co.

FACTORIES: Worcester, Leicester, Lowell,  
North Andover, Mass., Philadelphia, Pa.,  
Providence, Rhode Island. \* \* \*

SOUTHERN AGENCY, Charlotte, N. C.

WORCESTER, - MASSACHUSETTS.

**A. H. WASHBURN,**  
**Cotton Machinery and Equipment.**  
 Southern Agent, Saco & Pettee Machine Shops,  
 CHARLOTTE, N. C.

**EVAN ARTHUR LEIGH,**

Successor to E. A. Leigh & Company,

35 & 36 MASON BUILDING, - - BOSTON, MASS.

Sole Agent in the United States and Canada for PLATT BROTHERS & COMPANY, Ltd., by far the largest makers in the world of

**Cotton, Woolen and Worsted Machinery**  
 For All Classes of Work.

MATHER & PLATT'S Dyeing and Finishing Machinery.  
 JOSEPH SYKES BROS' Card Clothing for Cotton.  
 CRITCHLEY'S Card Clothing for Woolen and Worsted.  
 GEORGE HODSON, Ltd., Looms for Worsted, Etc.  
 TEXTILE MACHINERY ASSOC., Ltd., Flax, Hemp, Jute, Etc., Machinery.

**WILLIAM COUPE & Co.**

MANUFACTURERS OF

WILLIAM COUPE'S Celebrated Patent **EXCELSIOR**

ESTABLISHED  
 1865.



**Raw Hide Leather**

BELTING, LACE LEATHER,  
 Picker and Apron Leather.

STAFF PICKERS,

Strapping

FOR  
 Cotton, Woolen & Silk Mills

COUPE'S CELEBRATED

EXCELSIOR TANNED LACE and PICKER.



GREEN HIDE  
 PICKER LEATHER.

**SOUTH ATTLEBORO, MASS.**

E. & W.  
 LAMB AND CALF  
 ROLLER SKINS.

**MONEY SAVERS.**

ROLL  
 COVERERS'  
 TOOLS.

**SLASHER, ROLLER AND CLEARER CLOTHS.**

MADE BY THE

MEGUNTICOOK WOOLEN COMPANY, CAMDEN, MAINE.

SOLE AGENTS:

**C. R. ENGLISH CO.**

SAGER'S  
 ENGLISH  
 ROLLER LEATHER

301 Congress St., BOSTON, MASS.

COOK'S  
 LOOM  
 FORKS.

**OLD RELIABLE NO. 4.**  
**TUCKER'S STOP MOTION.**

Especially for Woolen Goods. The best Stop Motion ever put on a loom.

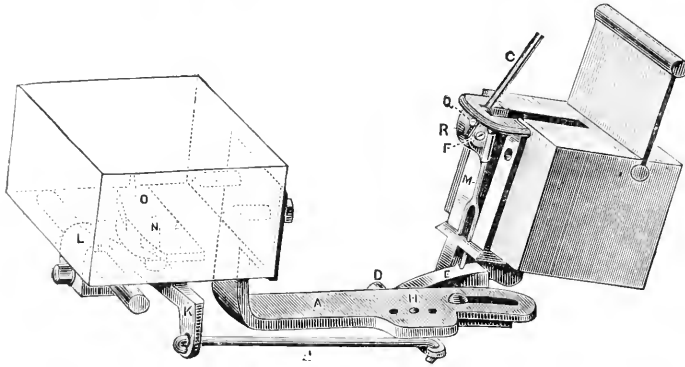

We are still making this stop motion and carry a full line of detail parts for repairs. We can and do promptly fill all orders for repairs or new stop motions.

Send all orders direct to

**TUCKER STOP MOTION CO., - - WINSTED, CT.**

**O. S. Bullock Machine Co.**

Manufacturers of Double and Twisters for soft and hard laid twines for seines, lines, etc., and dead Spindle Flyer Twisters for large soft laid cord, to take Bobbins from 3" to 7" traverse for Braiding.

**179 Broadway, - Cambridgeport, Mass.**

**COLORED  
 CHALK CRAYONS.**

Soft Crayons, manufactured expressly for Textile Mills, for marking roving yarn and cloth. They contain no oil or wax. Thirteen shades. Send for circular containing samples of colors, prices, etc.

**LOWELL CRAYON COMPANY,  
 LOWELL, MASS.**

**Chas. O. Murray,  
 Nashua, N. H.**

Manufacturer of

**SPOOLS, BOBBINS,  
 SKEWERS & SHUTTLES**

of every description.

Mail samples for quotations...

One of the largest and best equipped bobbin plants in the U. S.

**HENRY F. RICE, SUTTON, MASS.**

Manufacturer of **DOBBY CHAIN**

For all makes of English and American Dobbies with Rice's Patent Pegs. Large Stock of Chain, also Wood and Iron Pegs. Samples furnished on application.





W. H. WELCH PRESIDENT  
JULIUS D. HOSTER SEY. TREAS. & MGR  
J. FREEMAN, WILLIAMS, SUPT. & WH. SALES  
BY APPOINTMENT TO  
THE U. S. GOVERNMENT  
BELL TELEPHONE NO. 8426

DIRECTORS  
W. H. WELCH  
W. H. JONES  
E. H. JAMES  
R. THOMAS  
JULIUS D. HOSTER

BOBBINS, SEAMERS, SPOOLS,  
PICKER STRAIGHTEN LEVERS, ETC.  
FOR "TUB" MILLS  
TUBS AND SPOOLS FOR JUTE  
AND WIRE MILLS

FACTORY  
WOODSTOCK S. C.

TEXTILE MILL SUPPLIES AND  
VARIETY TURNINGS.

DISPLAY OF SAMPLES AT EXPOSITION  
CHARLESTON S. C. 1901-1902



**WOODSTOCK**  
**HARDWARE & SPOOL MFG. CO.**

FACTORY  
WOODSTOCK S. C.

TEXTILE MILL SUPPLIES AND  
VARIETY TURNINGS.

Charleston S. C.

BENJ. BOOTH.

PAUL LANG.

## BENJ. BOOTH & CO., LTD.,

MANUFACTURERS OF

# CARD - CLOTHING

Of Every Description.

Office and Factory, 1717-29 Bodine St., - PHILADELPHIA, PA.

## A. J. BECKLEY CO.



PERFORATED  
SHEET METAL  
OF ALL KINDS, FOR ALL USES  
FOR COAL, ORE, STONE AND SHAKER SCREENS  
JIGS, WASHERS, STAMP BATTERIES, MINING &  
SMELTING WORKS, SILVER REDUCTION &  
CONCENTRATING WORKS, &c. &c.  
SEPARATORS, FRICTIONAL PANS,  
CENTRIFUGAL PURIFIERS,  
GRAIN CLEANING  
MACHINERY,  
&c.

284 Pearl Street, New York City.

## PERFORATED COPPER

For Wool Scouring, Renser Boxes,  
Dyeing of Raw Cotton.

Duster Screens, Picker Screens.

PERFORATED SCREENS OF ALL KINDS.

Factory, Garwood, New Jersey.



J. M. ALLEN, President.  
W. M. B. FRANKLIN, Vice President.  
F. B. ALLEN, 2d Vice President.  
J. B. PIERCE, Secretary.  
L. B. BRAINARD, Treasurer.  
L. F. MIDDLEBROOK, Ass't Sec'y.

### High Grade Rubber Stamps

"We have things  
YOU WANT."



Ask for  
Our  
Handy  
Catalog  
E 2.

Sent  
on  
Re-  
quest.

<b>Band Dater</b> Good for 5 years	<b>25c</b>
<b>Band Numberer</b> Prints 1 to 9999	<b>25c</b>
<b>Best Pad</b> 2 1/4 x 3 1/2 Violet, Blue, Red or Black	<b>25c</b>
<b>Stamp Holder</b> For 3 stamps	<b>25c</b>

"WE SEND  
them prepaid."

The Yenlo Company, York, Pa.

# Frisbie Friction Clutches

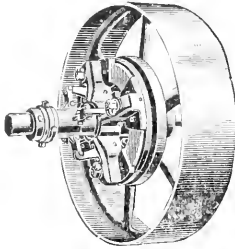

are the most substantially constructed on the market. They are

## BUILT ON CONSERVATIVE LINES

throughout and their capacities are never overrated.

For hard service there is nothing like them.

## SURE TO SATISFY.

Further Facts Furnished Free.

**THE EASTERN MACHINERY CO.,** NEW HAVEN, CONN.

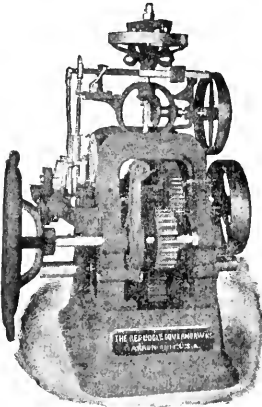

# Waterwheel Governors

... FOR ...

**TEXTILE MILLS,**  
ELECTRIC LIGHT, POWER & RAILROAD WORK.

Correspondence Solicited.

The Replogle Governor Works,  
**AKRON, OHIO.**

# Norwood Engineering Company

FLORENCE, MASS.

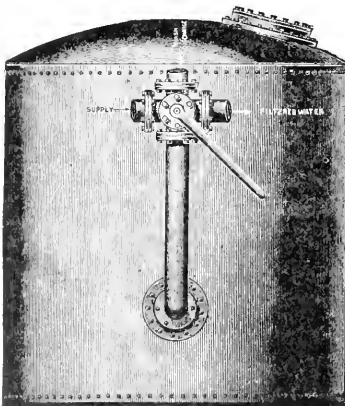

Wilson Filters,

Fire Hydrants,

Elevators.

Especially adapted for

# Textile Mill Requirements.

Write for Prices and Catalogues.

SKEIN AND SLUBBING MACHINES.

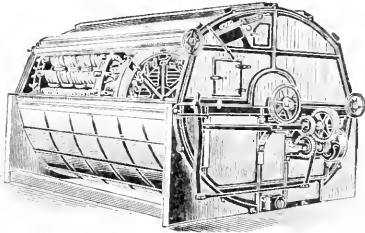

**SAVES**  
 75% in Labor.  
 30% in Winding  
 Steam and Dye Stuffs.  
 No Friction.  
 No Tangling.

**CAPACITY**  
 50 to 700 lbs. per batch.

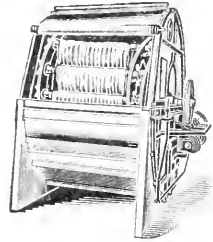

**THE KLAUDER-WELDON DYEING MACHINE CO.**  
**AMSTERDAM, N. Y.**

**Builders of Machines** For Skein—Worsted, Slubbing, Cotton and Silk.  
 " " and Warp Mercerizing and Skein Drying.  
 " Raw Stock—Cotton, Wool and Waste.  
 " Garments—Underwear, Hosiery and Caps.

**RAW WOOL AND COTTON MACHINES.**

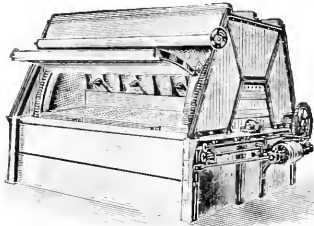

**CAPACITY**  
 200 to 1000 lbs.  
 per batch.

**SAVES**  
 50% in Labor be-  
 sides Steam and  
 Dye Stuffs. Prac-  
 tically inde-  
 structible. Leaves  
 stock in perfect  
 condition.

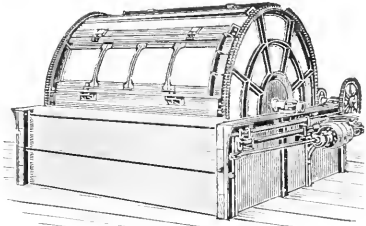

S. W. CRAMER, Charlotte, N. C., Southern Agent.

**Delahunty**  
**Dyeing**  
**Machine**  
**Co.**

PITTSSTON, PA.  
 Manufacturers of

**Dyeing Machinery**  
 for

Raw Stock, Wool, Cot-  
 ton, Rags, Shoddy, Waste  
 etc.

*Hosiery Dyeing,*  
 Shirts, and Drawers,  
 Hats and Caps.

**Chroming and**  
**Hosiery Oxidizing**  
**Machines.**

Machines are  
 placed on trial.  
 Guaranteed to do  
 first class work  
 or no sale.

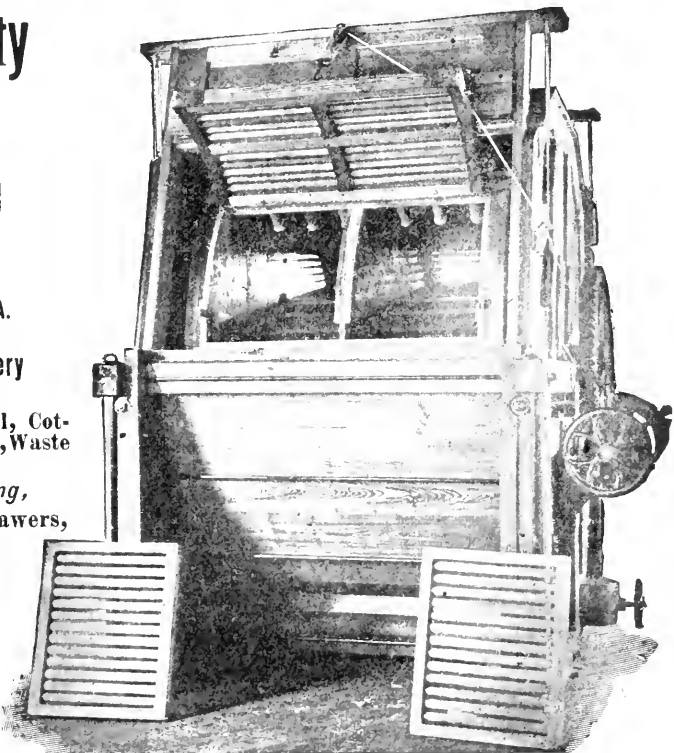

# CAMEL HAIR BELTING



FOR DYEHOUSE AND BLEACHERY USES.  
 ROSSENDALE, REDDAWAY BELTING & HOSE CO., NEWARK, N. J.  
 BOSTON OFFICE, 515 JOHN HANCOCK BUILDING.

## Modern Wet Finishing Machinery

Continuous Crabbing, Opening and Folding, Steam Finishing, Tentering, Sewing and Tacking Machines.

## Modern Bleaching Machinery

Washing, Chemicking, Squeezing, Open Soapers, Sewing Machines, Scutchers, and Angular Guides.

## Columbia Napping Machines

BIRCH BROS. Somerville Machine Works. (No connection with any other concern)  
 Send for Circulars and Prices. SOMERVILLE, MASS.

## TAUNTON-NEW BEDFORD COPPER CO.,

NEW BEDFORD, MASS.

## Copper Printing Rollers, Singe Plates and Sheets.

OUR GUARANTEE: { Superior Quality.  
 Prompt Shipments.

## CHAS. A. JOHNSON & CO.,

DEALERS IN

## CALICO PRINTERS', BLEACHERS & DYERS' SUPPLIES

22 Dey Street, New York, (Telephone, Cortland 568).  
 86 Weybosset St., Prov., R. I., (Telephone, 2726).

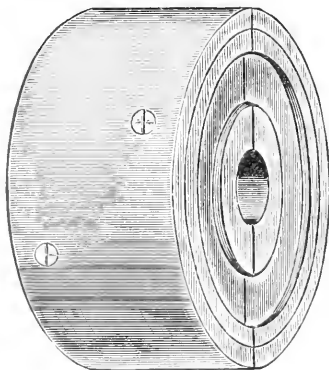

Let us Quote You Our Price for the Best  
**Hardwood Split Pulley**

ESPECIALLY ADAPTED  
**FOR TEXTILE MILLS.**

Model of Pulley Sent Free of Charge.

WE ALSO MANUFACTURE

**Oxidizing Machines, Tanks, Vats,**  
 and are dealers in all kinds of

**MILL SUPPLIES.**

**A. W. HOAC & CO.,**  
 238 Walnut St., READING, PA.



# Victor Koechl & Company

IMPORTERS OF

NEW YORK  
BOSTON  
PHILADELPHIA  
PROVIDENCE  
CHICAGO  
CHARLOTTE, N. C.

ALIZARINE,

ANILINE COLORS,

SYNTHETIC INDIGO M L B.

## John J. Keller & Co., Incorporated.

Boston.  
Providence.

104-106 Murray St., New York.

Atlanta.  
Philadelphia.

### ANILINE COLORS

Dyewood Extracts, Dyestuffs, Sumac and Nutgall Extracts, Fast Colors for Wool Dyeing, One Dip Cotton Colors, Novelties and Specialties for Calico Printers.

.. Sole Agents for ..

Aniline Color and Extract Works, Basle, Switzerland, & Grenzach, Germany.  
(Formerly JOHN R. GEIGY).

WEST  
INDIES



CHEMICAL  
WORKS, Ltd.

Manufacturers  
of pure

Logwood Extracts

Spanish Town,  
Jamaica, W. I.

DILLON & CO., 20 Cedar Street, New York,

Sole Agents for the United States and Canada.

### VERVIER'S MORDANT A PAT.

Cheapest and Best Mordant to use  
with Alizarine Dyes.

### VERVIER'S FAST ALIZARINE YELLOW G.

Is faster and works better in combination than  
any other Yellow yet introduced.

### VERVIER'S ALIZARINE BLUE. G. R. CONCENTRATED.

The best Alizarine Blue in the market. Darker shade of blue and  
more economical than any other.

J. W. LINNEHAN & CO., Fort Hill Square, BOSTON.

DYESTUFFS AND CHEMICALS.

A TRIAL ORDER

will convince you

of the merits

of these

articles.

I. J. R. MURLING, President.

WM. DIESTEL, Treasurer.

# Farbenfabriken of Elberfeld Co.

IMPORTERS OF

## Alizarine, Aniline Colors & Dye Stuffs

40 STONE STREET, NEW YORK.

BOSTON:

PHILADELPHIA:

CHICAGO.

32 India Street.

13-15 No. Water Street.

189 Kinzie Street.

---

### BERLIN ANILINE WORKS,

NEW YORK.

BOSTON.

PHILADELPHIA.

CHICAGO

CHARLOTTE, N. C.

CINCINNATI, O.

Manufacturers and sole importers of

### SULPHUR BLACK T AND EXTRA 2B

for raw cotton, yarns, warps and piece goods; indestructible by light and acids, absolutely fast to scouring.

**ONE OPERATION.****NO AFTER-TREATMENT.**

### UNION COLORS

for all kinds of fabrics, dyeing perfectly level shades. Aniline Colors for cotton, wool, silk, paper and leather.

Send for recipes, samples and particulars.

---

## AUTOCENE BLACK

A New Direct Dyeing Sulphur Black  
for Cotton.

FAST TO LIGHT, AIR, ALKALI, ACID AND STRONG SOAPING.

REQUIRING NO FIXING WITH METALIC SALTS NOR  
ATMOSPHERIC AGEING

### SYKES & STREET,

165 High Street.  
BOSTON.85 Water Street,  
NEW YORK.57 North Water Street,  
PHILADELPHIA.

C	<b>ASSELLA</b>	Artificial Dye Stuffs.
	<b>OLOR</b>	
	<b>OMPANY.</b>	
New York, Philadelphia, Boston, Providence, Charlotte, N. C., Montreal.		

**THE SHARPLESS DYEWOOD EXTRACT CO.,**

OFFICES: 648, 650, 651 THE BOURSE, PHILADELPHIA.

Warehouse: 22 N. Front St., PHILADELPHIA. Works: CHESTER, PA.

—MANUFACTURERS OF—

**DYEWOODS AND EXTRACTS.**

**LOGWOOD,  
FUSTIC,  
BARK,  
BLACK DYE,  
CUTCH.**

**H. S. VILA, 115 So. Second St., Philadelphia, Pa.**

**Importer and Dealer of . . . ANILINE COLORS, DYESTUFFS and EXTRACTS,**

**SPECIALTIES: DIRECT COLORS FOR COTTON, WOOL AND LEATHER.**

*J. C. Dempsey & Co.,*

**ANILINE COLORS and EXTRACTS**

29 N. Front St., - - Philadelphia.

Sole Agents in the United States for Williams Bros., Hounslow, Eng.

**FRANK BAILEY**

Has placed upon the market

**A Cold Air Drying Machine for Yarn.**

He is also building a first-class hot air machine. Claims to deliver yarn in far better condition than most machines.

He also makes kettle sticks and dry and sulphur house poles, also sticks to suit the Woistenholm machine from natural water grown cedar, and sticks to suit the Klauer-Weldon, and Lorimer machines from finer grades of lumber. These sticks have been thoroughly tested, and pronounced the best on the market. Guarantee satisfaction to buyers. Write for prices.

Cedar Brook; P. O., Camden Co., N. J.

**A. KLIPSTEIN & CO.,**

122 Pearl St.,

**NEW YORK.**

**Dyestuffs and Chemicals.**

BRANCHES:

**Boston, Philadelphia, Providence,  
Chicago, Hamilton, Ont.**

## NEW YORK <sup>AND</sup> BOSTON DYEWOOD COMPANY,

MANUFACTURERS

EXTRACTS OF LOGWOOD,  
FUSTIC, CUTCHINE AND  
HIGH GRADE HAEMATINES  
IN PASTE AND CRYSTALS  
FOR SILK AND WOOL.

IMPORTERS

ANILINE COLORS,  
INDIGO.

NEW YORK, PHILADELPHIA,  
BOSTON, HAMILTON, ONT.

WORKS: BROOKLYN, BOSTON.

MAIN OFFICE: NEW YORK CITY.

UPON APPLICATION

*The Hoechst & Hasselbacher*  
*Chemical Co.,*

100 WILLIAM ST., NEW YORK,  
WILL SEND PAMPHLET ON

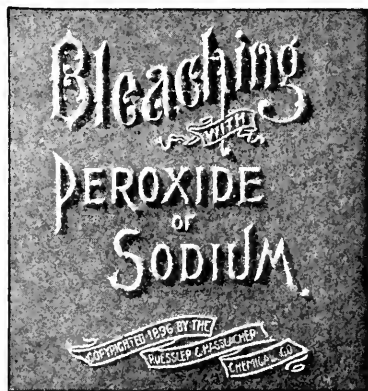

*Every Bleacher Should Know About It.*

FOR

Wool, Linen, Silk, Mixed Goods, Laces,  
Hosiery, Yarns, Mercerized Cotton, Etc.  
Peroxide of Sod. Works: Niagara Falls, N.Y.  
Chicago Office: Boston Office:  
16 N. Clark Street. 45 Kilby Street.

# FOREIGN SAMPLES

For WOOLENS and WORSTEDS Direct From

# FOREIGN SOURCES

LE MONITEUR DES ECHANTILLONS.

More Samples furnished with full weaving directions, easily understood by English readers, than are found in any other sample journal.

Issued twice each month, thus keeping designers in close touch with European styles

*Price Per Season (6 months, 12 numbers, 400 samples) \$11.00.*

Seasons begin with January and July.

Subscriptions received at this office where sample copies may be seen.

GUILD & LORD, 95 South St., Boston, Mass.

# Fire Protection to Mills

(Which means reduction in Insurance Rates.)  
Secured by using

## Caldwell Tanks AND Towers

Tanks built of Cypress.  
Towers built of Steel.

Our outfits endorsed by all the leading insurance companies.

Plans, Specifications and Estimates furnished, delivered only, or erected complete, for work in any part of the country.

For handsome illustrated catalogue, address

**W. E. CALDWELL CO.,**  
222 Brook St., - Louisville, Ky.

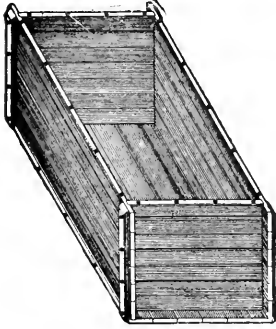

# Cypress Tanks and Vats

OF EVERY DESCRIPTION.

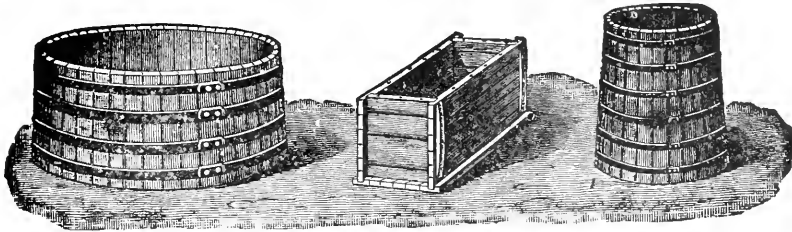

Cypress is remarkable for its great durability. There is no other wood so well adapted for the manufacture of Tanks, Vats, Cisterns, Dye Tubs, etc. We handle Cypress from the Stump, and our stock is of the best.

Our Tank Factory is complete. Let us know your wants.

**THE A. T. STEARNS LUMBER CO., BOSTON.**

## S. J. COREY,

273 Congress Street,

BOSTON, MASS.

IMPORTER AND DEALER IN

Anilines, Alizarine and other Fast Colors for Cotton, Wool and Silk. Special One Dip Colors for Union Goods. Shades Matched and full particulars sent on application. Dyewoods and Extracts, Haematine, Nubia One Dip Fast Black for Woolens, Lion Ammonia Wool Scourer.

## INDIGO, DYESTUFFS, CHEMICALS.

### BOSSON & LANE,

## Dyestuffs, Chemicals, Aniline Colors.

MANUFACTURERS OF

ANTI-CHLORINE for Bleaching Cotton. No acid, no soap.

ALIZARINE ASSISTANT.

BISULPHITE OF SODA.

TURKEY RED OIL.

SOLUBLE OIL.

BLACK DYES.

HEMATINE.

OLEINE.

KLAY FINISH for Woolen and Worsteds.

*Sizing Compounds for Cotton and Woolen Warps.*

36 Central Wharf,

BOSTON.

# WYANDOTTE WASHING SODA

## For SCOURING WOOL, Etc.

It will not only lessen your expense, but it will make your wool much softer, whiter and loftier.

If you are not using WYANDOTTE WASHING SODA, order one to five barrels from your supply house, using it according to directions, and if results are not satisfactory return the unused portion at our expense; the trial shall cost you nothing.

If interested write us for further particulars and directions.

**THE J. B. FORD COMPANY,**  
 MANUFACTURERS OF  
**WYANDOTTE WASHING SODA.**  
 Wyandotte, Mich.

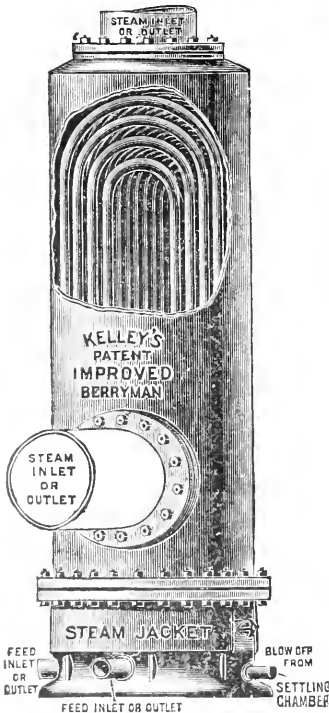

## Feed Water Heaters BY MAIL

Selling Feed Water Heaters BY MAIL is our specialty.

35 years as sellers and manufacturers is the price we have paid for our experience. Our improved machinery and methods for manufacturing greatly REDUCES THE COST AND YOU GET THE BENEFIT OF IT.

THE IMPROVED BERRYMAN WATER TUBE  
 (KELLEY'S PATENT.)

## FEED WATER HEATER AND PURIFIER.

This heater is designed with special reference to obtaining highest results and greatest durability. All materials are of a quality and weight to successfully withstand years of usage, and workmanship is of the highest grade.

**BENJ. F. KELLEY & SON**

MANUFACTURERS

91 Liberty Street. - - - New York.

# TABLE OF CONTENTS.

## 1902.

---

### Part I. Textile Manufacturers.

Textile Establishments of the United States, arranged by states and towns where they are located, with full data about each mill, also maps of the manufacturing states showing towns where there are mills . . . . .	65
Textile Establishments of the Dominion of Canada, with map of Ontario and Quebec . . . . .	283
Alphabetical Index of all the Mills in the United States . . . . .	295
Mill Data too late for Classification . . . . .	346
Mills with Worsted Machinery . . . . .	349
Number Spindles and Looms in the United States . . . . .	40-41

### Part II. The Yarn Trade Index.

List of Yarn Manufacturers Classified . . . . .	353
List of Yarn Dealers and Agents . . . . .	381

### Part III. Classified Lists of Commission and Order Mills, Dyeing and Finishing Establishments, Etc.

Commission and Order Work . . . . .	386
Bleaching, Dyeing, Printing and Finishing . . . . .	388
Shoddy and Extract Manufacturers . . . . .	397

### Part IV. Dealers in Raw Materials and Stock.

Wool and Shoddy Dealers and Brokers . . . . .	406
Cotton Dealers and Brokers . . . . .	411
Wholesale Rag Dealers . . . . .	403

### Part V. Agents and Buyers of Textile Fabrics.

Manufacturers' Selling Agents and Dry Goods Commission Merchants . . . . .	417
Manufacturing Clothiers . . . . .	432
Suit and Cloak Manufacturers . . . . .	447
Buyers Index of Textile Machinery and Supplies . . . . .	
Alphabetical Index to Advertisers . . . . .	62

**PRICE.**

<b>Traveller's Edition . . . . .</b>	<b>\$2.00</b>
<b>Office Edition . . . . .</b>	<b>2.50</b>

The Subscription price to the Textile World is \$2.00 per year without Directory, or including Traveller's Edition of Directory, \$3.00 per year.

71581

Copyright, 1902.

S. A. H. FUND

GUILD & LORD, Publishers,

95 South Street, Boston, Mass.

3 1903

# Woolen and Knitting Machinery Statistics of the United States for the Year 1902,

Giving the Sets of Woolen Cards in Woolen and Knitting Mills, the Worsted Combs, Looms, and Knitting Machines,

[The Shoddy Cards and Worsted Cards are not included under Woolen Sets or Combs.]

STATES.	WOOLEN.						KNITTING.			
	Sets of Woolen Cards (not including worsted cards or Shoddy Cards.)		Worsted Combs.		Looms.		Sets of Woolen Cards.		Knitting Machines.	
	1901	1902	1901	1902	1901	1902	1901	1902	1901	1902
Alabama.....		2			18	18			127	299
Arkansas.....	6	11			39	50				
California.....	43	49			295	236			106	206
Colorado.....					3	3				
Connecticut.....	486	481	56	60	4,171	4,288	149	128	1,696	1,912
Delaware.....	13	13			240	276			982	919
Florida.....									5	25
Georgia.....	39	32			733	689			1,556	2,078
Illaho.....	2	2			7	14			18	21
Illinois.....	63	61	3	3	436	402	15	12	2,628	2,486
Indiana.....	104	104			945	909	33	33	863	866
Iowa.....	42	36			215	197			278	284
Kansas.....	3	5			17	27			9	9
Kentucky.....	57	58	6	6	1,027	956	1		156	156
Louisiana.....									14	14
Maine.....	423	441	23	25	3,154	3,442			143	78
Maryland.....	25	58			281	323			835	820
Massachusetts.....	1,594	1,610	462	448	21,657	21,718	53	55	7,142	7,317
Michigan.....	45	55	1	1	182	164	26	19	2,926	3,151
Minnesota.....	39	36			166	165	3	3	537	544
Mississippi.....	27	24			260	246			27	82
Missouri.....	39	22			392	299			126	218
Montana.....	1	1			6	6				
Nebraska.....									20	20
New Hampshire.....	390	372	30	30	4,514	4,277	64	60	3,323	3,614
New Jersey.....	226	182	137	150	4,486	4,714	26	26	2,127	2,010
New York.....	472	480	120	120	5,622	5,496	722	683	12,112	12,272
North Carolina.....	19	23			318	329	5		3,496	2,507
North Dakota.....	2	3			20	20				
Ohio.....	96	96	6	8	813	709	16	15	2,027	2,211
Oregon.....	33	31	1		203	186		1	23	23
Pennsylvania.....	1,941	998	398	400	23,902	23,186	49	50	30,493	30,506
Rhode Island.....	410	430	239	276	10,482	10,628	19	19	1,496	1,458
South Carolina.....					40	40			1,244	1,306
South Dakota.....	7	7								
Tennessee.....	70	71			1,211	986			1,264	1,221
Texas.....	6	7		3	146	113			90	182
Utah.....	23	22	1		114	125			111	130
Vermont.....	131	131			902	963	43	43	523	511
Virginia.....	48	55			300	313	44	22	1,270	1,293
Washington.....	2	2			37	37			10	10
West Virginia.....	41	33			292	250	2	2	472	550
Wisconsin.....	64	63	9	9	345	333	20	20	3,080	3,246
Wyoming.....	1				3					
Total.....	6,124	6,104	1,492	1,539	87,904	87,073	1,290	1,191	82,955	84,555
Sets of Woolen Cards in Knitting Mills.....	1,290	1,191								
Total Sets of Woolen Cards.....	7,414	7,295								

\* See opposite page.



# The Cotton and Silk Machinery Statistics of the United States for the Year 1902,

Giving the number of Spindles and Looms in the Cotton and Silk Industries

STATES.	COTTON.				SILK.			
	Spindles		Looms		Spindles.		Looms.	
	1901	1902	1901	1902	1901	1902	1901	1902
Alabama .....	612,660	636,670	10,738	11,658				
Arkansas .....	22,660	25,610	281	422				
California .....	10,000	10,000	200	200	1,500	2,000	8	
Colorado .....	19,000	19,000	484	484				
Connecticut .....	1,104,172	1,105,107	22,535	22,518	55,100	74,946	1,558	1,822
Delaware .....	35,000	34,552	838	838	4,000	4,000	300	260
Georgia .....	1,303,917	1,404,146	30,363	31,865				
Illinois .....	33,000	33,600	812	801			238	163
Indiana .....	118,500	150,668	2,767	2,864				
Indian Territory .....		23,000		750				
Kansas .....	3,000	2,061						
Kentucky .....	66,736	71,056	991	1,351				
Louisiana .....	80,052	75,052	1,884	2,884				
Maine .....	875,780	878,132	23,451	23,192	5,000	5,000	200	200
Maryland .....	158,284	167,502	3,066	3,009			51	288
Massachusetts .....	8,230,142	8,302,869	189,436	192,422	24,500	20,775	948	1,019
Michigan .....		1,020	40	40	3,700	17,500	225	250
Mississippi .....	125,324	128,927	3,092	3,532				
Missouri .....	13,904	3,194	356	361				
Nebraska .....	15,488	15,488	416	416				
New Hampshire .....	1,343,165	1,218,145	39,389	34,775	4,000	4,000	400	400
New Jersey .....	426,316	453,000	3,145	2,747	334,494	338,394	25,858	26,063
New York .....	904,556	822,400	15,947	15,703	244,712	254,900	6,374	7,002
North Carolina .....	1,692,333	1,736,399	35,588	36,654	30,000	30,000	1,450	1,450
North Dakota .....	100	100						
Ohio .....	18,000	15,000	98	98			26	26
Pennsylvania .....	392,538	381,363	14,511	15,050	751,922	921,196	18,028	18,717
Rhode Island .....	2,167,326	2,185,566	44,337	44,744	1,960	1,960	74	83
South Carolina .....	2,185,020	2,284,558	60,093	61,516				
Tennessee .....	220,993	230,441	4,516	4,422				
Texas .....	80,145	94,645	2,172	2,534				
Utah .....	450	450		10			4	4
Vermont .....	120,960	106,308	2,538	2,539				
Virginia .....	180,147	221,551	5,770	6,662	30,000	30,000	325	325
West Virginia .....			23	23				
Wisconsin .....	32,584	23,312	1,085	373				
Totals .....	22,601,072	22,978,702†	520,982	527,457	1,430,888	1,704,581	56,067	58,072

\* The decrease in the number of sets of woolen cards in 1902, compared with 1901, is due principally to the abandonment of many small woolen mills of a few sets capacity scattered all through the country, but principally in the Middle and Western States, and also to the falling off in the use of woolen cards in knitting mills, where cotton, worsted and merino yarn bought from outside yarn mills is largely taking the place of the yarn formerly made on woolen machinery. The loss due to these two causes, together with fires, etc., have more than off-set the installation of new machinery.

† The comparatively small increase in the number of cotton spindles is principally due to the fact that the figures for 1901 included the machinery in mills projected and under construction. As mills projected are not always built, it is thought more conservative to include henceforth in the statistics only the machinery in mills actually in operation, and the figures for 1902 are prepared on this basis in all the different branches and do not include machinery in mills projected or under construction. The actual increase in number of cotton spindles was approximately one million spindles.

# CROMPTON & KNOWLES LOOM WORKS,

WORCESTER, MASS.,

BRANCH WORKS, PROVIDENCE, R. I.

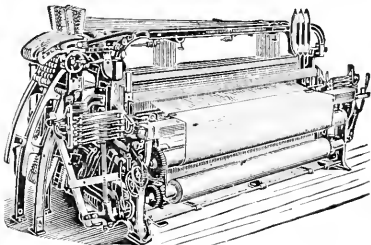

Crompton "1896"  
Woolen and Worsted Loom.

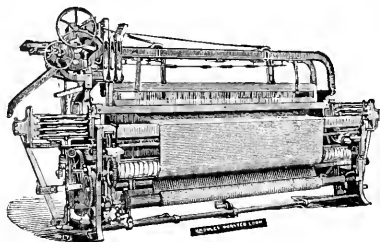

Knowles Heavy Worsted Loom.

## PLAIN and FANCY LOOMS,

For weaving every variety of TEXTILE FABRIC, also

Wool

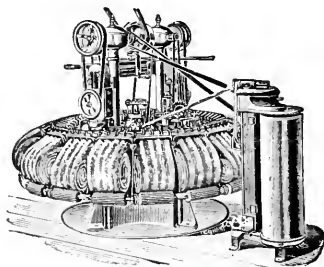

Crompton-Noble Comb.

Combs

for

## Worsted Manufacture.

Unsurpassed for  
Combing Coarse, Medium, or Fine Wools.

# BUYERS' INDEX

FOR

## Machinery and Mill Supplies.

The following Classified Index contains the addresses of the principal builders of Textile Machinery, and Dealers in Mill Supplies. If any particular machine or article wanted is not specified, the publishers of the Textile World will be pleased to tell where it may be had.

IN WRITING PARTIES PLEASE MENTION THE TEXTILE WORLD DIRECTORY.

The Yarn Trade Index, the Commission and Order Work Lists, and the Dyeing, Bleaching and Finishing Lists on pages 353 to 384 of the Directory should be consulted for such needs.

### Air Moistening System.

American Moistening Co., 150 Devonshire St., Boston.

### Anti-Chlorine.

Bosson & Lane, 36 Central Wharf, Boston, Mass. (See ad.)

### Aprons, Worsted.

North Chelmsford Supply Co., North Chelmsford, Mass. (See ad.)

### Architects and Mill Engineers.

See Mill Engineers.

### Automatic Feeds for Cotton & Wool.

See Feeds.

### Automatic Sprinklers.

International Sprinkler Co., Phila., Pa.

### Baling Presses.

Boomer & Boschert Press Co., Syracuse, N. Y.

Sullivan Machinery Co., Claremont, N. H. (See ad.)

### Balling Machine.

Torrance Mfg. Co., 18 Davis St., E. Newark, N. J.

### Bandings.

Crabb, William & Co., Newark, N. J. (See ad.)

Moore, C. & Co., 12 So. 5th St., Phila.

Rodgers, David G., Paterson, N. J. (See ad.)

Toohy, M. J. & Co., Fall River, Mass. Y.

Whittier Mills, Springfield, Mass. (See ad.)

Young, Wm. M., 241 Mascher St., Phila. (See ad.)

### Bands and Labels.

See Labels and Tickers.

### Baskets.

Lane, W. T. & Bro., Port Chester, N. Y. (See ad.)

### Beaming and Warping Machinery.

Aitemus, Jacob K., 2818 N. 4th St., Phila. (See ad.)

Lever, Oswald, Lehigh Ave. and Mascher St., Phila.

### Belting.

See also Mill Supplies.

Alexander Bros., 410 No. 3d St., Phila., Pa.

American Supply Co., Providence, R. I. (See ad.)

Boston Belting Co., Boston, Mass.

Coupe, Wm. & Co., So. Attleboro, Mass. (See ad.)

Crabb, William & Co., Newark, N. J. (See ad.)

Dodge Mfg. Co., Mishawaka, Ind.

Coburn, Fred S., Woonsocket, R. I. (See ad.)

Houghton, E. F. & Co., Phila., Pa.

Jeffery Manufacturing Co., Columbus, Ohio.

Main Belting Co., 1219 Carpenter St., Phila., Pa.

North Chelmsford Supply Co., North Chelmsford, Mass. (See ad.)

Popham, Henry & Son, Newark, N. J.

Rodgers, David G., Paterson, N. J. (See ad.)

Rossendale, Reddaway Belting & Hose Co., Newark, N. J. (See ad.)

Shultz Belting Co., St. Louis, Mo.

Smith, James Woolen Machinery Co., Phila., Pa. (See ad.)

Street, R. R. & Co., 184, 186 Washington St., Chicago, Ill. (See ad.)

Cling-Surface Co., 190 Virginia St., Buffalo, N. Y.

Main Belting Co., 1219 Carpenter St., Phila., Pa.

Stephenson Mfg. Co., 8 Liberty St., Albany, N. Y.

Street, R. R. & Co., 184, 186 Washington St., Chicago, Ill. (See ad.)

### Belt Dressing.

Alexander Bros., 410 N. 3d St., Phila., Pa.

Cling-Surface Co., 190 Virginia St., Buffalo, N. Y.

Main Belting Co., 1219 Carpenter St., Phila., Pa.

Stephenson Mfg. Co., 8 Liberty St., Albany, N. Y.

Street, R. R. & Co., 184, 186 Washington St., Chicago, Ill. (See ad.)

### Belt Hooks.

Bristol Co., The, Waterbury, Conn.

Shultz Belting Co., St. Louis, Mo.

### Belt Lacc.

See Belting.

### Bindings.

See Tapes and Braids.

### Bleachers.

See page 388.

### Bleaching Materials.

Bosson & Lane, Boston. (See ad.)

Roessler & Hasselcher Chemical Co., 190 William St., New York. (See ad.)

### Block Cutting for Printing.

Atlas Copper Stamp Works, 15 Whitehall St., New York.

Hope, John & Sons Engraving & Mfg. Co., Providence, R. I. (See ad.)

### Blower Work.

Allington & Curtis Mfg. Co., 29 Otis St., East Cambridge, Mass.

American Blower Co., Detroit, Mich.

Boston Blower Co., Hyde Park, Mass.

Buffalo Forge Co., Buffalo, N. Y.

Hartford Blower Co., Hartford, Conn. (See ad.)

N. E. Ventilating & Heating Co., 926 Manton Ave., Providence.

# The Best Pickers.



In the Cotton Field nothing equals the  
**DARKY COTTON PICKER.**

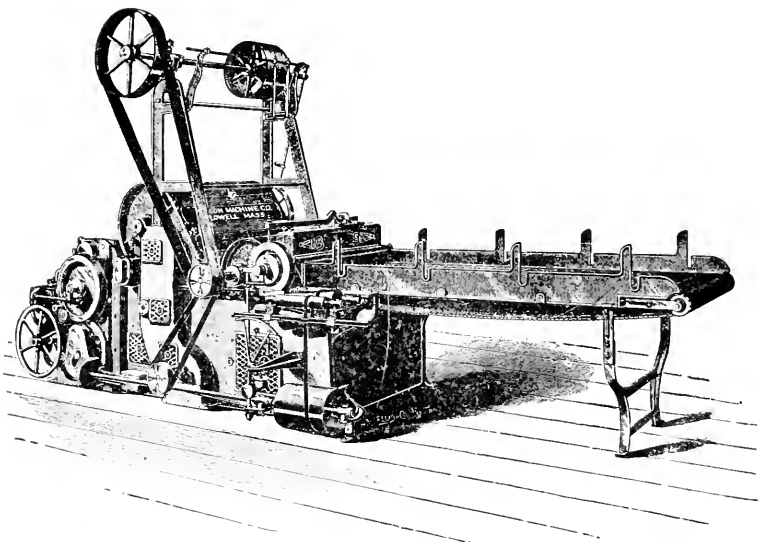

In the Cotton Mill nothing equals the  
**KITSON COTTON PICKERS.**

## **KITSON MACHINE CO., Lowell, Mass.**

**Largest Builders of Cotton Openers and Lappers  
in the World.**

**STUART W. CRAMER, Southern Agt., Charlotte, N. C. and  
Equitable Building, Atlanta, Ga.**

- Sterling Blower and Pipe Mfg. Co., The,  
44 Huyshope St., Hartford, Conn.  
Sturtevant, B. F. Co., Boston, Mass.
- Bobbins, Spools, Shuttles, etc.**  
American Supply Co., Providence, R. I. (See ad.)  
Coburn, Fred S., Woonsocket, R. I. (See ad.)  
McGuire, John A., Co., Claremont, N. H.  
Murray, Charles O., Nashua, N. H. (See ad.)  
Southern Bobbin Co., Greensboro, N. C.  
Street, R. R. & Co., 184, 186 Washington St., Chicago, Ill. (See ad.)  
Sweet & Doyle, Cohoes, N. Y. (See ad.)  
Tebbetts, E. L., & Co., Locke's Mill, Me. (See ad.)  
Vermont Spool & Bobbin Co., Essex Junction, Vt. (See ad.)  
Woodstock Hardwood & Spool Mfg. Co., Charlestown, S. C. (See ad.)
- Boilers.**  
See Steam Boilers.
- Boiler Insurance.**  
See Steam Boiler Insurance.
- Boxes, Fibre.**  
Laminar Fibre Co., North Cambridge, Mass.  
Spaulding-Perkins Co., No. Rochester, N. H. (See ad.)  
Walrus Fibre Mfg. Co., North Cambridge, Mass.
- Boxes, Paper.**  
See Paper Boxes.
- Boxes, Wooden.**  
Pearson, J. T., Kensington, Pa.  
Thompson, Jas. A., Lowell, Mass. (See ad.)  
Vermont Spool & Bobbin Co., Essex Junction, Vt. (See ad.)
- Box Shooks.**  
Thompson, Jas. A., Lowell, Mass. (See ad.)  
Vermont Spool & Bobbin Co., Essex Junction, Vt. (See ad.)
- Braiding Machinery.**  
New England Butt Co., 304 Pearl St., Providence, R. I.  
Textile Machine Works, Reading, Pa.
- Braids.**  
See Tapes and Braids.
- Brass (Perforated).**  
See under Perforated Metal.
- Brass Stamps.**  
See Stamps and Stencils.
- Brokers.**  
See Lists in Back of Directory.
- Brushers.**  
See Napping Machines.
- Brushes.**  
Felton, S. A., Son Co., Manchester, N. H.  
Mason Brush Works, Worcester, Mass. (See ad.)  
North Chelmsford Supply Co., North Chelmsford, Mass. (See ad.)  
Parks & Woolson Machine Co., Springfield, Vt. (See ad.)  
Rhode Island Brush Co., Providence, R. I. (See ad.)
- Brushing Machines.**  
Birch Bros., Somerville, Mass. (See ad.)  
Butterworth, H. W. & Sons Co., Philadelphia, Pa.  
Curtis & Marble Machine Co., Worcester, Mass. (See ad.)
- Granger Foundry & Machine Co., Providence, R. I.  
McCreary, E., Cohoes, N. Y. (See ad.)  
Parks & Woolson Machine Co., Springfield, Vt. (See ad.)  
Rusden Machine Co., Warren, R. I.
- Burr Pickers.**  
Atlas Foundry & Machine Co., Belleville, N. J.  
Curtis & Marble Machine Co., Worcester, Mass. (See ad.)  
Sargent's C. G. Sons, Graniteville, Mass. (See ad.)  
Smith, James, Woolen Machinery Co., Phila., Pa. (See ad.)
- Calico Printers' Machinery and Supplies.**  
Arlington Machine Works (Arthur Birch), Arlington Heights, Mass.  
Birch Brothers (Albert Birch), Somerville, Mass. (See ad.)  
Butterworth, H. W., Sons & Co., Phila., Pa.  
Granger Foundry & Machine Co., Providence, R. I.  
Johnson, Chas. A. & Co., 22 Dey St., New York. (See ad.)  
Phillips, The Thomas Co., Providence, R. I.  
Rusden Machine Co., Warren, R. I.  
Taunton-New Bedford Copper Co., New Bedford, Mass. (See ad.)
- Canvas Baskets.**  
Lane, W. T. & Bro., Port Chester, N. Y. (See ad.)
- Caps (Steel).**  
Bamford & Smith, Pascoag, R. I. (See ad.)
- Carbonizing.**  
See page 356.
- Carbonizing Machines.**  
Kitson Machine Co., Lowell, Mass. (See ad.)  
Phila. Lrying Machinery Co., 6721 Germantown Ave., Phila., Pa. (See ad.)  
Phila. Textile Machinery Co., Hancock and Somerset Aves., Phila., Pa. (See ad.)  
Sargent's, C. G. Sons, Graniteville, Mass. (See ad.)  
Smith, James Woolen Machinery Co., Phila., Pa. (See ad.)
- Card Clothing.**  
American Card Clothing Co., Worcester, Mass. (See ad.)  
Ashworth, Elijah, Fall River, Mass.  
Booth, Benj. & Co., 1717 Bodine St., Philadelphia, Pa. (See ad.)  
Crabb, William & Co., Newark, N. J. (See ad.)  
Edma Card Clothing Co., 423 S. 5th St., Camden, N. J.  
English, C. R., Co., 301 Congress St., Boston. (See ad.)  
Furbush, M. A. & Son Machine Co., Twelfth and Market Sts., Camden, N. J. (See ad.)  
Leigh, Evan A., 35 Mason Building, Boston. (See ad.)  
Riley, C. E. & Co., 281 Congress St., Boston. (See ad.)  
Street, R. R. & Co., 184, 186 Washington St., Chicago, Ill. (See ad.)
- Carded Cotton.**  
Indian Orchard Co., Indian Orchard, Mass. (See ad.)
- Carders' Tools.**  
Brown, W. H., Mechanic St., Worcester, Mass.
- Card Feeds.**  
See Feeds.

**Card Grinding Machinery.**

Hardy Machine Co., Biddeford, Me.  
Smith, Jas., Woolen Machinery Co.,  
Phila., Pa. (See ad.)

**Carding Machinery.**

See Cotton Machinery, also Woolen  
Machinery.

**Carpet Machinery.**

Altemus, Jacob K., 2816 N. 4th St., Phila-  
delphia, Pa. (See ad.)  
Crompton & Knowles Loom Works,  
Worcester, Mass. (See ad.)  
Curtis & Marble Machine Co., Worces-  
ter, Mass. (See ad.)  
Furbush, M. A. & Son, Machine Co.,  
Twelfth and Market Sts., Camden,  
N. J. (See ad.)  
Howard, Geo. C., Lansdowne, Pa., and  
2123 Market St., Phila., Pa.  
Parks & Woolson Machine Co., Spring-  
field, Vt. (See ad.)  
Smith, James, Woolen Machinery Co.,  
Phila., Pa. (See ad.)

**Carpet Shears.**

Parks & Woolson Machine Co., Spring-  
field, Vt. (See ad.)

**Castings.**

American Ferrofix Co., 20 Broad St.,  
N. Y.  
Livermore, Homer F., 85 Pearl St., Bos-  
ton, Mass. (See ad.)

**Chemicals.**

See Dye Stuffs and Chemicals.

**Chenille Cutting Machines.**

Lever, Oswald, Lehigh Ave. and Mas-  
cher St., Phila.

**Clearer Cloths.**

See Mill Supplies.

**Cling Surface.**

Cling-Surface Mfg. Co., 199 Virginia  
St., Buffalo, N. Y.

**Clocks.**

Eco-Magneto Co., 620 Atlantic Av., Bos-  
ton.  
Howard, E. Clock Co., The, 493 Wash-  
ington St., Boston. (See ad.)  
Newman Clock Co., 50 Masonic Temple,  
Chicago, Ill. (See ad.)  
Riggs & Brothers, 310 Market St., Phila.,  
Pa. (See ad.)

**Cloth Boards.**

Chaffee Bros., Oxford, Mass.  
Thompson, Jas. A., Lowell, Mass. (See  
ad.)  
Vermont-Spool & Bobbin Co., Essex  
Junction, Vt. (See ad.)

**Cloth Folding Machines.**

See Measuring and Folding Machines.

**Cloth Strength Testers.**

Burke & Hanford, 621 Broadway, New  
York.

**Clutches.**

See Friction Clutches.

**Coal Tar Chemicals.**

Roessler & Hasslacher Chemical Co.,  
100 William St., New York. (See ad.)

**Combs, Circles and Fullers.**

Crabb, William & Co., Newark, N. J.  
(See ad.)  
Crompton & Knowles Loom Works,  
Worcester, Mass. (See ad.)  
North Chelmsford Supply Co., North  
Chelmsford, Mass. (See ad.)  
Townsend, Thomas, 157 Orange St.,  
Providence, R. I.

**Comber Needles.**

Crabb, William & Co., Newark, N. J.  
(See ad.)  
Townsend, Thomas, 157 Orange St.,  
Providence, R. I.

**Cone Tubes.**

See Cop Tubes.

**Cone Winders.**

See Winders.

**Contractor and Builder.**

Ferguson, John W., Paterson Nat.  
Bank Bldg., Paterson, N. J.

**Conveying Machinery.**

Jeffrey Mfg. Co., The, Columbus, O.

**Conveyors, Pneumatic.**

Sterling Blower & Pipe Mfg. Co., The,  
Hartford, Conn.  
Boston Blower Co., Hyde Park, Mass.  
Buffalo Forge Co., Buffalo, N. Y.  
Sturtevant, B. F., Co., 34 Oliver St.,  
Boston.

**Cop Tubes (Paper).**

Pairpoint Mfg. Co., New Bedford, Mass.  
(See ad.)

**Cop Tubes (Tin).**

Getchell, S. S., & Son, Woonsocket, R.  
I. (See ad.)

**Copper Gaskets.**

U. S. Mineral Woolen Co., 149 Liberty  
St., New York.

**Copper Printing Rollers.**

Phillips, Thomas Co., Providence, R. I.  
Taunton-New Bedford Copper Co., New  
Bedford, Mass. (See ad.)

**Copper Roll Engravers.**

See Engravers of Copper Rolls.

**Copper Screens.**

See Perforated Copper.

**Copper Sheets.**

Taunton-New Bedford Copper Co., New  
Bedford, Mass. (See ad.)

**Copper Work for Dyers.**

Butterworth, H. W. & Son Co., Phila.,  
Pa.  
Granger Foundry & Machine Co.,  
Providence, R. I.  
Phillips, Thomas Co., Providence, R. I.  
Taunton-New Bedford Copper Co., New  
Bedford, Mass. (See ad.)

**Cordage.**

American Mfg. Co., 63-65 Wall St., New  
York.

**Cords.**

See Tapes, Braids and Cords.

**Cotton.**

See also List on page 411.  
Brantley & Co., A. P., Blackshear, Ga.  
(See ad.)  
Charles, William B., Amsterdam, N. Y.  
(See ad.)  
Connell, John J., 239 N. Front St., Phil-  
adelphia, Pa. (See ad.)  
Indian Orchard Co., Indian Orchard,  
Mass. (See ad.)  
Reis & Co., 620 Atlantic Ave., Boston.  
(See ad.)  
Riley, C. E. & Co., 281 Congress St.,  
Boston. (See ad.)  
Street, R. R. & Co., 184, 186 Washing-  
ton St., Chicago, Ill. (See ad.)  
Wolf, W., & Sons, 620 Atlantic Ave.,  
Boston, Mass. (See ad.)

**Cotton Bale Ties.**

De Haven Mfg. Co., 50 Columbia  
Heights, Brooklyn, N. Y.

**Cotton Machinery.**

Altemus, Jacob K., 2816 No. 4th St.,  
Phila., Pa. (See ad.)  
Ashworth, Elijah, Fall River, Mass.  
Atherton, A. T., Machine Co., Paw-  
tucket, R. I. (See ad.)  
Barber & Coleman, 11 Pemberton  
Square, Boston, Mass. (See ad.)  
Brownell, G. L., Worcester, Mass.  
Butterworth, H. W. & Son Co., Phila.,  
Pa.

**“Nothing is either great or small  
except by comparison.”**

This accounts for the GREATNESS of the Picking  
Machinery built by

**The A. T. ATHERTON MACHINE CO.,**

**PAWTUCKET, R. I.**

-----MANUFACTURERS OF-----

**COTTON MACHINERY.**

- Crompton & Knowles Loom Works, Worcester, Mass. (See ad.)  
Curtis & Marble Machine Co., Worcester, Mass. (See ad.)  
Draper Company, Hopedale, Mass. (See ad.)  
Easton & Burnham Machine Co., Pawtucket, R. I.  
Fairmount Machine Co., 22d and Wood Sts., Phila., Pa.  
Foster Machine Co., Westfield, Mass. (See ad.)  
Houghton, L. T., Worcester, Mass.  
Howard & Bullough American Machine Co., Pawtucket, R. I. (See ad.)  
Kilburn, Lincoln & Co., Fall River, Mass. (See ad.)  
Kitson Machine Co., Lowell, Mass. (See ad.)  
Leigh, Evan A., 35 Mason Building, Boston. (See ad.)  
Lever, Oswald, Lehigh Ave. and Mascher St., Phila.  
Lowe, Stephen C., 186 Devonshire St., Boston. (See ad.)  
Lowell Machine Shop, Lowell, Mass. (See ad.)  
Mason Machine Works, Taunton, Mass. (See ad.)  
McKerrow, H. G., 31 State St., Boston.  
Parks & Woolson Machine Co., Springfield, Vt. (See ad.)  
Payne, G. W. & Co., Pawtucket, R. I. (See ad.)  
Phila. Drying Machinery Co., 672 Germantown Ave., Philadelphia, Pa. (See ad.)  
Philadelphia Textile Machinery Co., Hancock and Somerset Sts., Philadelphia, Pa. (See ad.)  
Phillips, Thomas Co., Providence, R. I.  
Riley, C. E. & Co., 281 Congress St., Boston, Mass. (See ad.)  
Ring Frame Thread Protector Co., The, Amsterdam, N. Y.  
Robbins, O. A., Charlotte, N. C. (See ad.)  
Saco & Pettee Machine Shops, Newton Upper Falls, Mass. (See ad.)  
Sargent's, C. G. Sons, Graniteville, Mass. (See ad.)  
Schofield, Geo. L., Phila., Pa.  
Smith, James, Woolen Machinery Co., Phila., Pa. (See ad.)  
Universal Winding Co., 95 South St., Boston, Mass. (See ad.)  
Washburn, A. H., Charlotte, N. C. (See ad.)  
Whitin Machine Works, Whitinsville, Mass. (See ad.)
- Cotton Openers and Lappers.**  
Atherton, A. T., Machine Co., Pawtucket, R. I. (See ad.)  
Howard & Bullough American Machine Co., Pawtucket, R. I. (See ad.)  
Kitson Machine Co., Lowell, Mass. (See ad.)  
Leigh, Evan Arthur, 35-36 Mason Bldg., Boston, Mass. (See ad.)  
Lowe, Stephen C., 186 Devonshire St., Boston. (See ad.)  
Philadelphia Textile Machinery Co., Hancock and Somerset Sts., Philadelphia, Pa. (See ad.)  
Saco & Pettee Machine Shops, Newton Upper Falls, Mass. (See ad.)
- Cotton Softeners.**  
Bosson & Lane, Boston, Mass. (See ad.)  
Holbrook Mfg. Co., 466 Washington St., New York. (See ad.)  
O. K. Soap Co., 968 Franklin St., Philadelphia, Pa.
- Cotton Waste.**  
See lists pages 399-401

---

**Saco and Pettee Machine Shops,**

Newton Upper Falls, Mass., U. S. A.

# COTTON MACHINERY

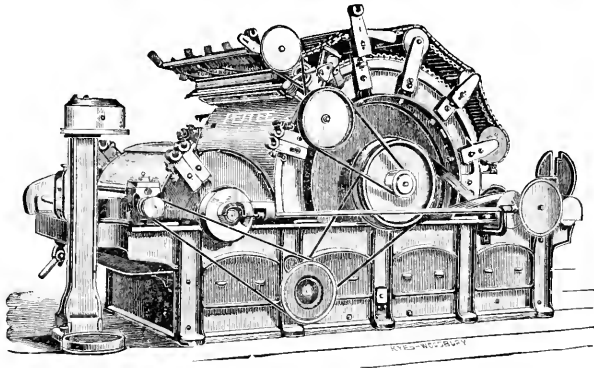

**PICKERS, REVOLVING FLAT CARDS,  
DRAWING FRAMES,  
RAILWAY HEADS, SLUBBING,  
INTERMEDIATE AND ROVING  
FRAMES,  
SPINNING FRAMES, SPOOLERS.**

SHOPS: 

Biddeford, Maine.

Newton Upper Falls, Mass.

Southern Agent: A. H. WASHBURN, Charlotte, N. C.



**Cotton Yarns.**

See Yarn Index, page 353.

**Credits.**

National Mercantile Agency, New York and Boston.

**Crochet Machine Needles.**

Merrrow Machine Co., Hartford, Conn.

**Crochet Machines.**

Merrrow Machine Co., Hartford, Conn.

**Cutters for Knit Fabrics.**

Goodwin, J. C., 2d and Diamond Sts.,

Phila., Pa.

Kennedy, Thos. (Cutters, etc.), Cohoes, N. Y.

McCreary, E., Cohoes, N. Y. (See ad.)

**Cylinders, Tin (for Frames and Mules).**

Getchell, S. S. & Son, Woonsocket, R. I. (See ad.)

**Dating and Time Stamps.**

Riggs & Bros., 310 Market St., Phila., Pa. (See ad.)

**Dextrine.**

Stein, Hirsh & Co., 165 Duane St., New York. (See ad.)

**Dobby Chains.**

Rice, H. F., Sutton, Mass. (See ad.)

**Dobling and Rolling Machines.**

Birch Bros., Somerville, Mass. (See ad.)

Bullock, O. S. Machine Co., Cambridge, Mass. (See ad.)

Butterworth, H. W. & Sons Co., Philadelphia, Pa.

Curtis & Marble Machine Co., Worcester, Mass. (See ad.)

Granger Foundry & Machine Co., Providence, R. I.

Parks & Woolson Machine Co., Springfield, Vt. (See ad.)

**Drainers.**

Arlington Machine Works (Arthur Birch), Arlington Heights, Mass.

Beckley, A. J. Co., Garwood, N. J. (See ad.)

Birch Bros. (Albert Birch), Somerville, Mass. (See ad.)

Phillips, Thos. Co., Providence, R. I.

**Dryers.**

Antisdel, E. M., Utica, N. Y.

Bailey, Frank, Cedar Brook, N. J. (See ad.)

Birch Bros., Somerville, Mass. (See ad.)

Boston Blower Co., Hyde Park, Mass.

Buffalo Forge Co., Buffalo, N. Y.

Butterworth, H. W. & Sons Co., Phila.

Granger Foundry & Mch. Co., Providence, R. I.

Hartford Blower Co., Hartford, Conn. (See ad.)

Hunter, Jas., Machine Co., No. Adams, Mass. (See ad.)

Kenyon, D. R. & Son, Raritan, N. J.

Massachusetts Fan Co., Waltham, Mass.

Philadelphia Drying Machinery Co., Phila., Pa. (See ad.)

Philadelphia Textile Machinery Co., Phila., Pa. (See ad.)

Phillips, Thomas & Co., Providence, R. I.

Rusden Machine Co., Warren, R. I.

Sargent's, C. G. Sons, Graniteville, Mass. (See ad.)

Smith, James Woolen Machinery Co., Phila., Pa. (See ad.)

Street, R. R. & Co., 184, 186 Washington St., Chicago, Ill. (See ad.)

Sturtevant, B. F. & Co., 34 Oliver St., Boston, Mass.

**Dry Poles.**

Bailey, Frank, Cedar Brook, N. J.

(See ad.)

**Dust Collectors.**

Allington & Curtis Mfg. Co., 29 Otis St., East Cambridge, Mass.

Boston Blower Co., Hyde Park, Mass.

Buffalo Forge Co., Buffalo, N. Y.

Hartford Blower Co., Hartford, Conn.

(See ad.)

Philadelphia Drying Machinery Co., 6721 Germantown Ave., Philadelphia, Pa. (See ad.)

Philadelphia Textile Machinery Co., Hancock and Somerset Sts., Philadelphia, Pa. (See ad.)

Sterling Blower & Pipe Mfg. Co., Hartford, Conn.

Sturtevant, B. F., Boston, Mass.

**Dusters.**

See Wool and Waste Dusters.

**Dyehouse Cans.**

Hill, James Mfg. Co., Providence, R. I. (See ad.)

Laminar Fibre Co., North Cambridge, Mass.

Walrus Fibre Mfg. Co., No. Cambridge, Mass.

**Dyeing, Drying, Bleaching, and Finishing Machinery.**

American Blower Co., Detroit, Mich.

American Tool & Machine Co., Boston, Mass.

Antisdel, E. M., Utica, N. Y.

Arlington Machine Works (Arthur Birch), Arlington Heights, Mass.

Boston Blower Co., Hyde Park, Mass.

Birch Bros., Somerville, Mass. (See ad.)

Buffalo Forge Co., Buffalo, N. Y.

Butterworth, H. W. & Sons Co., Philadelphia, Pa.

Curtis & Marble Machine Co., Worcester, Mass. (See ad.)

Delahunty Dyeing Machine Co., Pitts-  
ton, Pa. (See ad.)

Fairmount Machine Co., 22d and Wood  
Sts., Philadelphia, Pa.

Granger Foundry & Machine Co.,  
Providence, R. I.

Hartford Blower Co., Hartford, Conn.  
(See ad.)

Howard, Geo. C., Lansdowne, Pa. and  
2123 Market St., Philadelphia, Pa.

Hunt, Rodney Machine Co., Orange,  
Mass. (See ad.)

Kenyon, D. R. & Son, Raritan, N. J.

Klauder-Weldon Dyeing Machine Co.,  
Amsterdam, N. Y. (See ad.)

Leigh, Evan Arthur, 35-36 Mason Bldg.,  
Boston, Mass. (See ad.)

Massachusetts Fan Co., Waltham, Mass.

Parks & Woolson Machine Co., Spring-  
field, Vt. (See ad.)

Philadelphia Drying Machinery Co., 2721  
Germantown Ave., Philadelphia, Pa.  
(See ad.)

Philadelphia Textile Machinery Co.,  
Hancock and Somerset Sts., Phila-  
delphia, Pa. (See ad.)

Philadelphia Textile Specialty Mach-  
ine Co., 500 N. 12th St., Philadel-  
phia, Pa. (See ad.)

Phillips, Thomas Co., Providence, R. I.

Riley, C. E. & Co., 281 Congress St.,  
Boston, Mass. (See ad.)

Rusden Machine Co., Warren, R. I.

Smith, James Woolen Machinery Co.,  
Philadelphia, Pa.

Street, R. R. & Co., 184, 186 Washington  
St., Chicago, Ill. (See ad.)

Sturtevant, B. F. Co., 34 Oliver St.,  
Boston, Mass. (Drying.)

**Dyers, Bleachers and Finishers.**

See also Classified List on page 388.

American Yarn Printing Works, 134, 150 No. 22d St., Philadelphia, Pa. (See ad.)

Brophy's, T. Sons, Jasper St., Philadelphia, Pa.

Burton, Andrew, Penn Dye Works, Penn St. and Belfield Ave., Germantown, Pa. (See ad.)

Charlotte Dye Works, 1210 Oriana St., Philadelphia, Pa. (See ad.)

Cohoes Dye Works, Cohoes, N. Y.

Cranston Worsted Mills (yarns), Bristol, R. I. (See ad.)

Davidson & Brooke, 2560 No. 3d St., Philadelphia, Pa.

Firth & Foster Co., Kensington, Pa.

Greenwood, R., & Bault, Frankford, Pa.

Harris, T. A. & Co., Continental Dye Works, Philadelphia, Pa. (See ad.)

Home Bleach & Dye Works, Pawtucket, R. I.

Holmes, John C. Co., Springfield, Vt. (See ad.)

Howard & Co., Rahway, N. J.

Lorimer's, The Wm. H. & Sons Co., Ontario and Lawrence Ste., Philadelphia, Pa. (See ad.)

Molt Bros., Millbury, Mass. (See ad.)

New York Mills, New York Mills, N. Y. (See ad.)

Pawtucket Dyeing & Bleaching Co., Pawtucket, R. I. (See ad.)

Pennypack Yarn Finishing Co., Holmesburg, Pa.

Pond, Lily Co., New Haven, Conn.

Providence Mills Mfg. Co., 55 Girard Ave., Philadelphia, Pa.

Rowland, Samuel (Knit Goods Bleachers), Schuylkill Haven, Pa. (See ad.)

Walcott & Campbell Spinning Co., New York Mills, N. Y. (See ad.)

Windle, A. D. & W. W., West Millbury, (See ad.)

Whittier Mills, Chattahoochee, Ga. (See ad.)

**Dye Sticks.**

Bailey, Frank, Cedar Brook, N. J. Camden Co.

Haedrich, E. M., 311½ Walnut St., Philadelphia, Pa.

**Dyestuffs and Chemicals.**

Atteaux, F. E. & Co., 174-76 Purchase St., Boston, Mass.

Berlin Aniline Works, 215 Water St., New York.

Bischoff & Co., 57 Park Place, N. Y.

Bosson & Lane, 36 Central Wharf, Boston, Mass. (See ad.)

Cassella Color Co., 182 Front St., New York. (See ad.)

Corey, S. J., 273 Congress St., Boston, Mass. (See ad.)

Dempsey, J. C. & Co., 29 N. Front St., Philadelphia, Pa. (See ad.)

Dillon & Co., 20 Cedar St., New York. (See ad.)

Dubois, A. N., Philadelphia, Pa. (See ad.)

Farbenfabriken of Elberfeld Co., 40 Stone St., New York. (See ad.)

Ford, J. B. Co., Wyandotte, Mich. (See ad.)

Fortner, L. B., 37 Strawberry St., Philadelphia, Pa.

Geisenheimer & Co., 189 Front St., New York.

Holliday & Sons, Ltd., Read, 7 Platt St., New York.

Johnson, Chas. A. & Co., 22 Dey St., New York. (See ad.)

Keller, John J. & Co., 104-106 Murray St., New York. (See ad.)

Klipstein, A. & Co., 122 Pearl St., New York. (See ad.)

Koechl, Victor & Co., 122 Hudson St., New York. (See ad.)

Kutroff, Pickhardt & Co., 125 Duane St., New York. (See ad.)

Linnehan, J. W. & Co., 185 High St., Boston. (See ad.)

Molt Bros., Millbury, Mass. (See ad.)

N. Y. & Boston Dye Wood Co., 55 Beekman St., New York.

Oil Seeds Pressing Co., 15-25 Whitehall St., New York.

Roessler & Hasslacher Chemical Co., 100 William St., New York. (See ad.)

Sharpless Dye Wood Extract Co., The Bourse, Philadelphia, Pa. (See ad.)

Street, R. R. & Co., 184-186 Washington St., Chicago, Ill. (See ad.)

Sykes & Street, 85 Water St., New York. (See ad.)

Thayer, E. M. & Co., 106 Broad St., Boston.

Vila, H. S., 115 South Second St., Philadelphia, Pa. (See ad.)

**Dynamos.**

See Electrical Machinery.

**Edgings.**

See Knit Goods, Edgings, etc.

**Electrical Machinery.**

Buffalo Forge Co., Buffalo, N. Y.

General Electric Co., 44 Broad St., New York. (See ad.)

Sturtevant, B. F. Co., 34 Oliver St., Boston.

**Electric Construction.**

General Electric Co., 44 Broad St., New York. (See ad.)

Whaley, W. B. Smith, 1012 Tremont Bldg., Boston, Mass. (See ad.)

**Electric Fans.**

American Blower Co., Detroit, Mich.

Buffalo Forge Co., Buffalo, N. Y.

General Electric Co., 44 Broad St., New York. (See ad.)

Philadelphia Drying Machine Co., 6721 Germantown Ave., Phila. (See ad.)

Philadelphia Textile Machinery Co., Hancock and Somerset Sts., Philadelphia, Pa. (See ad.)

Sturtevant, B. F. Co., Jamaica Plain, Mass.

**Electric Lighting.**

General Electric Co., 44 Broad St., New York. (See ad.)

**Electric Motors.**

General Electric Co., 44 Broad St., New York. (See ad.)

Sturtevant Co., B. F., Boston, Mass.

**Electrotyping and Printing.**

Whitcomb, B. C. & Co., Boston, Mass.

**Elevators.**

Cohoes Foundry & Machine Co., Cohoes, N. Y.

Eastern Machinery Co., New Haven, Conn. (See ad.)

Fairmount Machine Co., Philadelphia, Pa.

Howard, Geo. C., Lansdowne, Pa., and 2123 Market St., Phila., Pa.

Jeffrey Mfg. Co., The, Columbus, O.

Norwood Engineering Co., Florence, Mass. (See ad.)

Salem Elevator Works, Salem, Mass.

**Embroideries.**

See Knit Goods, Trimmings, etc.

**Employers' Time Recorders.**

Riggs & Brothers, 310 Market St., Phila., Pa. (See ad.)

**Engineers, Mechanical.**

See also Mill Engineers.

Buffalo Forge Co., Buffalo, N. Y.

Ferguson, John W., Paterson, N. J.

Green, Samuel M., Holyoke, Mass.

Sturtevant Co., B. F., Boston.

**Engines.**

See Steam Engines.

**Engravers of Copper Rolls.**

Atlas Stamp Works, 15 Whitehall St.,  
New York.  
Hope, John & Sons Eng. & Mfg. Co.,  
Providence, R. I. (See ad.)

**Exhaust Fans.**

See Ventilating Apparatus.

**Exhaust Pipe Heads.**

Burt Mfg. Co., The, Akron, O.  
Sterling Blower & Pipe Mfg. Co., The,  
Hartford, Conn.  
Sturtevant, B. F., 34 Oliver St., Boston,  
Mass.

**Fans.**

See Ventilating Apparatus.

**Feeds.**

Atlas Foundry & Machine Co., Belle-  
ville, N. J.  
Kenyon, D. R. & Son, Raritan, N. J.  
Philadelphia Drying Machinery Co.,  
6721 Germantown Ave., Phila., Pa.  
(See ad.)  
Philadelphia Textile Machinery Co.,  
Hancock and Somerset Sts., Phila-  
delphia, Pa. (See ad.)  
Sargent's C. G. Sons, Graniteville,  
Mass. (See ad.)  
Smith, James Woolen Machinery Co.,  
Phila., Pa. (See ad.)

**Feed Water Heaters.**

Kelly, Benj. F. & Son, 91 Liberty St.,  
New York. (See ad.)  
Green Fuel Economizer Co., Mat-  
teawa, N. Y.  
Scaife, W. B. & Sons, Pittsburg, Pa.

**Feed Water Pumps.**

Goulds Mfg. Co., Seneca Falls, N. Y.  
Scaife, W. B. & Sons, Pittsburg, Pa.

**Filters.**

Automatic Water Purifying Co., 45  
Broadway, New York.  
Norwood Engineering Co., Florence,  
Mass. (See ad.)  
Scaife, Wm. B. & Sons, Pittsburg, Pa.

**Finishing Machinery.**

See Dyeing, Drying, Bleaching and  
Finishing.  
Birch Bros., Somerville, Mass. (See  
ad.)  
Butterworth, H. W. & Sons Co., Phila-  
delphia, Pa.  
Curtis & Marble Machine Co., Worces-  
ter, Mass. (See ad.)  
Granger Foundry & Machine Co.,  
Providence, R. I.  
Kenyon, D. R. & Son, Raritan, N. J.  
McCreehy, E., Cohoes, N. Y. (See ad.)  
Parks & Woolson Machine Co., Spring-  
field, Vt. (See ad.)  
Phillips, Thos., Co., The, Providence,  
R. I.  
Riley, C. E. & Co., 285 Congress St.,  
Boston. (See ad.)  
Street, R. R. & Co., 184, 186 Washington  
St., Chicago, Ill. (See ad.)

**Fire Extinguishers.**

Riggs & Bros., 310 Market St., Phila.,  
Pa. (See ad.)

**Fire Hydrants.**

Norwood Engineering Co., Florence,  
Mass. (See ad.)

**Fleecing Machines.**

See Napping Machines.

**Flocks.**

See page 401.

**Fluted Rolls.**

Cohoes Foundry & Machine Co., Co-  
hoses, N. Y.  
Riley, C. E. & Co., 281 Congress St.,  
Boston. (See ad.)  
Thurston, A. G. & Son, Box 58, Fall  
River, Mass.

**Forges.**

Buffalo Forge Co., Buffalo, N. Y.  
Sturtevant Co., The B. F., Jamaica  
Plain Station, Boston, Mass.

**Friction Clutches.**

American Tool & Machine Co., 109  
Beach St., Boston, Mass.  
Dodge Mfg. Co., Mishawaka, Ind.  
Eastern Machinery Co., New Haven,  
Conn. (See ad.)  
Hunter, Jas. Machine Co., No. Adams,  
Mass. (See ad.)  
Rusden Machine Co., Warren, R. I.  
Smith, Jas., Woolen Machinery Co.,  
Phila., Pa. (See ad.)  
Street, R. R. & Co., 184, 186 Washington  
St., Chicago, Ill. (See ad.)

**Friction Hoisting Drums.**

Eastern Machinery Co., New Haven,  
Conn. (See ad.)

**Friction Pulleys.**

Eastern Machinery Co., New Haven,  
Conn. (See ad.)

**Friction Winding Drums.**

Eastern Machinery Co., New Haven,  
Conn. (See ad.)

**Fuel Economizer.**

Kelly, Benj. F. & Son, 91 Liberty St.,  
New York. (See ad.)  
Green Fuel Economizer Co., Matteawa,  
N. Y.  
Steam Boiler Equipment Co., 29 W.  
Houston St., New York.

**Fulling Mills.**

Hunt, Rodney, Machine Co., Orange,  
Mass. (See ad.)  
Hunter, Jas., Machine Co., No. Adams,  
Mass. (See ad.)  
Kenyon, D. R. & Son, Raritan, N. J.

**Garnet Machines.**

Phila. Textile Machinery Co., Hancock  
and Somerset Sts., Phila. (See ad.)  
Smith, Jas., Woolen Machinery Co.,  
Phila. (See ad.)

**Gas Engines.**

Jones, Lewis, 60 $\frac{1}{2}$  and Media Sts.,  
Phila., Pa.

**Gas Exhausters.**

Sturtevant Co., B. F., Boston, Mass.

**Gas Singeing Machines.**

See Singeing Machines.

**Gear Cutting Machines.**

Whitton, The D. E. Co., New London,  
Conn. (See ad.)

**Gears.**

New Process Raw Hide Co., Syracuse,  
N. Y.

**Generators.**

See Electric Machinery.

**Gigs.**

Curtis & Marble Machine Co., Worces-  
ter, Mass. (See ad.)  
Parks & Woolson Machine Co., Spring-  
field, Vt. (See ad.)

**Gums.**

See Sizing, Starch and Gums.

**Hackles.**

See Combs, Circles, Fallers, etc.

**Harnesses.**

See Reeds and Harnesses.

**Heating.**

See Ventilating.

**Heddles.**

American Supply Co., Providence, R. I.  
(See ad.)  
Emmons Loom Harness Co., Lawrence,  
Mass. (See ad.)  
Steel Heddle Mfg. Co., Germantown  
Ave., Phila., Pa.

- Watson, L. S., Mfg. Co., Leicester, Mass. (See ad.)
- Hoisting Machinery.**  
Eastern Machinery Co., New Haven, Conn. (See ad.)  
Larrabee, John E., Amsterdam, N. Y.
- Hose.**  
Boston Belting Co., Boston, Mass.  
Coburn, Fred S., Woonsocket, R. I. (See ad.)  
Rosendale, Reddaway Belting & Hose Co., Newark, N. J. (See ad.)
- Hosiery Boards.**  
Pearson, J. T., Kensington, Pa.
- Hosiery Labels.**  
See Labels and Tickets.
- Humidifying Apparatus.**  
American Moistening Co., 150 Devonshire St., Boston, Mass.  
Boston Blower Co., Hyde Park, Mass.  
Buffalo Forge Co., Buffalo, N. Y.  
Coburn, Fred S., Woonsocket, R. I. (See ad.)  
Hartford Blower Co., Hartford, Conn. (See ad.)  
Sturtevant, B. F., Co., Boston, Mass.
- Hydro-Extractors.**  
American Tool & Machine Co., 109 Beach St., Boston, Mass.  
Riley, C. E. & Co., Boston, Mass. (See ad.)  
Rusden Machine Co., Warren, R. I.  
Street, R. R. & Co., 184-186 Washington St., Chicago, Ill. (See ad.)
- Ironing Machines for Knit Goods.**  
Craw, J. W., Laundry Machinery Co., So. Norwalk, Conn.
- Jacquard Cards.**  
Rogers, H. E., South Manchester, Conn.
- Knit Goods Bleachers.**  
See page 393.
- Knit Goods Edgings, Trimmings, etc.**  
Cathcart, John & Co., 115 Franklin St., New York. (See ad.)  
Chapin, George W., 229 Church St., Phila. (See ad.)  
Charles, William B., Amsterdam, N. Y. (See ad.)  
Cheney Bros., silk goods, 479 Broome St., New York. (See ad.)  
Erie-berger Mfg. Co., Edgings, Germantown, Phila. (See ad.)  
Germantown Lace & Edging Works, Germantown, Pa. (See ad.)  
Hepper & Horwitz, lacings, 30 Howard St., New York.  
Kroun & Flite Mfg. Co., Allegheny Ave. and Emerald St., Phila. (See ad.)  
Weimar Bros., 1817 E. New York St., Phila., Pa.
- Knit Goods Finishing Machines, Crochet, etc.**  
Adams Top Cutting Machine Co. (McMichael & Wildman Mfg. Co.), Norristown, Pa.  
Arnold Sewing Machine Co., 216 High St., Newark, N. J.  
Craw, J. W., Laundry Machinery Co., So. Norwalk, Conn.  
Hart, Chas., Frankford, Pa.  
Krusc & Murphy Mfg. Co., 455 West 26th St., New York.  
McCreary, E., Cohoes, N. Y. (See ad.)  
Morrow Machine Co., The, Hartford, Conn.  
Nye & Tredick, 606 Arch St., Phila.  
Spence & Rideout, Nashua, N. H. (See ad.)  
Taylor, James, 835 Arch St., Philadelphia, Pa. (See ad.)  
Union Button Sewing Machine Co., Boston, Mass.  
Union Special Sewing Machine Co., 47 Leonard St., New York. (See ad.)  
Von Buchwald, W. C., 129 N. 7th St., Phila., Pa. (See ad.)  
Willcox & Gibbs Sewing Machine Co., New York. (See ad.)
- Knitting Machine Burs.**  
Bredon's, Wm. Son, Amsterdam, N. Y. (See ad.)  
Cooper, Chas., Bennington, Vt.  
Crane Mfg. Co., Lakeport, N. H. (See ad.)  
Tompkins Bros., Troy, N. Y.
- Knitting Machine Cylinders.**  
Branson Machine Co., 506 North American St., Phila. (See ad.)  
Brinton, H. & Co., 213 Race St., Philadelphia, Pa. (See ad.)  
Cook, Stephen S., 624-26 Race St., Philadelphia, Pa. (See ad.)  
Paxton & O'Neill, 127 Broad St., Philadelphia, Pa. (See ad.)  
Stafford & Holt, Little Falls, N. Y. (See ad.)
- Knitting Machinery.**  
Adams Top Cutting Machine Co., 11 Broadway, New York.  
American Knitting Machine Co., 6th and Arch Sts., Philadelphia.  
Babcock Machine Works, Fort Plain, N. Y.  
Beattie's Machine Works, Cohoes, N. Y. (See ad.)  
Branson Machine Co., 506 North American St., Phila. (See ad.)  
Brinton, H. & Co., 213 Race St., Philadelphia, Pa. (See ad.)  
Cook, Stephen S., 624 Race St., Philadelphia, Pa. (See ad.)  
Cooper, Chas., Bennington, Vt.  
Crane Mfg. Co., Lakeport, N. H. (See ad.)  
Excelsior Knitting Machine Mfg. Co., Allentown, Pa.  
Goodwin, J. C., Second and Diamond Sts., Phila., Pa. (Cutters.)  
Jenckes, E., Mfg. Co., Pawtucket, R. I.  
Jones, Lewis, 60½ and Media Sts., Phila., Pa.  
Kennedy, Thos., cutters, etc., Cohoes, N. Y.  
Keystone Knitting Machine Mfg. Co., 40 North 7th St., Philadelphia, Pa. (See ad.)  
Lamb Knitting Machine Co., Chicopee Falls, Mass.  
Leighton Machine Co., Manchester, N. H. (See ad.)  
Lindley, George W., 5122 Wakefield St., Germantown, Pa. (See ad.)  
Mayo Knitting Machine & Needle Co., Franklin, N. H.  
McMichael & Wildman Mfg. Co., Norristown, Pa. (See ad.)  
Mueller, Arthur, 760 Lexington Ave., Brooklyn, N. Y.  
Nye & Tredick, 606 Arch St., Phila., Pa.  
Paxton & O'Neill, 127 Broad St., Philadelphia, Pa. (See ad.)  
Payne, G. W. & Co., Pawtucket, R. I. (Winders.) (See ad.)  
Pepper Mfg. Co., Lakeport, N. H. (See ad.)  
Scott & Williams, 2079 E. Cumberland St., Phila.  
Snyder, The Homer P., Mfg. Co., Little Falls, N. Y.  
Stafford & Holt, Little Falls, N. Y. (See ad.)  
Taylor, James, 835 Arch St., Phila., Pa. (See ad.)  
Tompkins Bros., Troy, N. Y.

**Knitting Needles.**

- Branson Machine Co., 506 North American St., Philadelphia, Pa. (See ad.)  
 Brecon, Wm. & Son, Amsterdam, N. Y. (See ad.)  
 Brinton, H. & Co., 213 Race St., Philadelphia, Pa. (See ad.)  
 Cooper, Chas., Bennington, Vt.  
 Crane Mfg. Co., Lakeport, N. H. (See ad.)  
 Corey, Wm., Co., Manchester, N. H.  
 Dodge Needle Co., Manchester, N. H. (See ad.)  
 Ives, Loyal T., New Brunswick, N. J. (See ad.)  
 Keystone Knitting Machine Mfg. Co., 49 North 7th St., Philadelphia, Pa. (See ad.)  
 Lamb Knitting Machine Mfg. Co., Chicopee Falls, Mass.  
 Manufacturers' Supplies Co., 66 No. 4th St., Phila.  
 Mayo Knitting Machine & Needle Co., Franklin, N. H.  
 Page Needle Co., Chicopee Falls, Mass.  
 Treat, Orion, Manchester Green, Conn.  
 Wardwell Needle Co., Lakeport, N. H.

**Knitter for Spoilers.**

- Barber & Colman, 11 Pemberton Sq., Boston, Mass. (See ad.)

**Labeling Machine.**

- Saranac Electrical Mfg. Co., St. Joseph, Mich.

**Labels and Tickets.**

- Docker-Foster Co., 123 North Fifth St., Phila., Pa.  
 Johnson, Thomas, 2600 N. 5th St., Philadelphia, Pa. (See ad.)  
 Saranac Electrical Mfg. Co., St. Joseph, Mich.  
 Steinthal, M. & Co., 267 W. Broadway, New York. (See ad.)

**Laboratory Outfits.**

- Feidt, Geo. D. & Co., 525 Arch St., Phila., Pa.

**Lacings for Underwear.**

- See Knit Goods, Edgings, Trimmings, etc.

**Leather.**

- Houghton, E. F. & Co., Philadelphia, Pa.

**Leather Boards.**

- Rogers, H. E., South Manchester, Conn.

**Looms.**

- Crompton & Knowles Loom Works, Worcester, Mass. (See ad.)  
 Draper Co., Hopedale, Mass. (See ad.)  
 Fairmount Machine Co., 22d and Wood Sts., Philadelphia, Pa.  
 Howard, Geo. C., Lansdowne, Pa., and 213 Market St., Phila., Pa. (For wire.)  
 Kilburn, Lincoln & Co., Fall River, Mass. (See ad.)  
 Leigh, Evan Arthur, 35-36 Mason Bldg., Boston, Mass. (See ad.)  
 Lowell Machine Shop, Lowell, Mass. (See ad.)  
 Mason Machine Works, Taunton, Mass. (See ad.)  
 Smith, James, Woolen Machinery Co., Phila., Pa. (See ad.)  
 Whitin Machine Works, Whitinsville, Mass. (See ad.)

**Loom Picker Manufacturers.**

- Coburn, Fred S., Woonsocket, R. I. (See ad.)  
 Crompton & Knowles Loom Works, Worcester, Mass. (See ad.)

**Loopers.**

- Beattie's Machine Works, Cohoes, N. Y. (See ad.)

**Lubricating Oils.**

See Oils.

**Lumber.**

- Stearns, A. T., Lumber Co., Neponset, Mass. (See ad.)

**Lumpers.**

- Gerry, Geo. & Son, Athol, Mass.  
 Jefferson, Ed. & Bro., 28 Strawberry St., Phila., Pa.

**Machinery Dealers.**

- Schofield, Geo. L., 123 No. Front St., Philadelphia, Pa.  
 Street, R. R. & Co., 184, 186 Washington St., Chicago, Ill. (See ad.)  
 Taylor, Jas., Knitting, 835 Arch St., Phila.

**Malls.**

- Waldner, J., Paterson, N. J.

**Manufacturers Selling Agents.**

See page 417.

**Measuring and Folding Machines.**

- Curtis & Marble Machine Co., Worcester, Mass. (See ad.)  
 Elliott & Hall, 54½ Harmon St., Worcester, Mass.  
 Fabric Measuring & Packaging Co., Broadway and Murray St., New York. (See ad.)  
 McCreary, E., Cohoes, N. Y. (See ad.)  
 Parks & Woolson Machine Co., Springfield, Vt. (See ad.)

**Mechanical Draft.**

- American Blower Co., Detroit, Mich.  
 Buffalo Forge Co., Buffalo, N. Y.  
 Boston Blower Co., Hyde Park, Mass.  
 Hartford Blower Co., Hartford, Conn. (See ad.)  
 Massachusetts Fan Co., Waltham, Mass.  
 Sturtevant, B. F., Co., 31 Oliver St., Boston, Mass.

**Mechanical Engineers.**

See Engineers.

**Mercerized Yarns.**

See page 368.

**Mercerizers.**

See page 368.

**Mercerizing Machinery.**

- Butterworth, H. W. & Son Co., Philadelphia, Pa.  
 Granger Foundry & Machine Co., Providence, R. I.  
 Klauder-Weldon Dyeing Machine Co., Amsterdam, N. Y. (See ad.)  
 Philadelphia Textile Specialty Machine Co., 500 N. 12th St., Phila., Pa. (See ad.)  
 Rusden Machine Co., Warren, R. I.

**Mill Architects.**

See Mill Engineers.

**Mill Baskets.**

- Laminar Fibre Co., North Cambridge, Mass.  
 Spalding-Perkins Co., No. Rochester, N. H. (See ad.)  
 Lane, W. T. & Bro., Port Chester, N. Y. (See ad.)

**Mill Brushes.**

See Brushes.

**Mill Crayons.**

- Lowell Crayon Co., Lowell, Mass. (See ad.)

**Mill Engineers.**

- Ferguson, John W., Paterson Nat. Bank Bldg., Paterson, N. J.  
 Gray, Arthur F., 53 State St., Boston, Mass. (See ad.)  
 Green, Samuel M., Hilyoke, Mass.  
 Lockwood, Greene & Co., 35 Federal St., Boston. (See ad.)

Stuck, Adolph, 179 Summer St., Boston.  
(See ad.)  
Whaley, W. B. Smith & Co., 1328 Main  
St., Columbia, S. C. (See ad.)

**Mills for Sale.**

Denny, R. B., 143 Federal St., Boston.  
(See ad.)

**Mill Supplies.**

American Supply Co., Providence, R. I.  
(See ad.)  
Bamford & Smith, Pascoag, R. I. (See  
ad.)  
Bristol Co., The, Waterbury, Conn.  
Buckley's, Benj., Son, Gun Mill, Pater-  
son, N. J.  
Chase Pulley Co., Providence, R. I.  
Coburn, Fred S., Woonsocket, R. I.  
(See ad.)  
Coupe, Wm. & Co., So. Attleboro,  
Mass. (See ad.)  
Crabb, William & Co., Newark, N. J.  
(See ad.)  
Dixon Lubricating Saddle Co., Bristol,  
R. I.  
Dodge Mfg. Co., Mishawaka, Ind.  
Easton & Burnham Machine Co., Paw-  
tucket, R. I.  
Emmons Loom Harness Co., Lawrence,  
Mass. (See ad.)  
English, C. R. Co., 301 Congress St.,  
Boston. (See ad.)  
Hill, Jas., Mfg. Co., Providence, R. I.  
(See ad.)  
Hoag, A. W. & Co., Reading, Pa. (See  
ad.)  
Houghton, E. F. & Co., Phila., Pa.  
Jefferson, Edward & Bros., 28 Straw-  
berry St., Philadelphia, Pa.  
Jeffrey Mfg. Co., Columbus, O.  
Lane, W. T. & Bro., Port Chester, N.  
Y. (See ad.)  
Larrabee, John E., Amsterdam, N. Y.  
Livmore, H. F., Boston, Mass. (See  
ad.)  
Main Belting Co., 1219 Carpenter St.,  
Phila., Pa.  
Manufacturers' Supplies Co., 66 North  
Fourth St., Phila., Pa.  
North Chelmsford Supply Co., North  
Chelmsford, Mass. (See ad.)  
Oil Seeds Pressing Co., 15-25 Whitehall  
St., New York.  
Riley, C. E. & Co., 281 Congress St.,  
Boston. (See ad.)  
Rodgers, David G., Paterson, N. J. (See  
ad.)  
Robbins, A. O., Charlotte, N. C. (See  
ad.)  
Rossendale, Reddaway Belting & Hose  
Co., Newark, N. J. (See ad.)  
Shaw, Victor, Ring Traveler Co., Provid-  
ence, R. I.  
Smith, James, Woolen Machinery Co.,  
Phila., Pa. (See ad.)  
Southern Bobbin Co., Greensboro, N. C.  
Spaulding-Perkins Co., No. Rochester,  
N. H. (See ad.)  
Steel Heddle Mfg. Co., 1824 Germantown  
Ave., Phila., Pa.  
Street, R. R. & Co., 184-186 Washington  
St., Chicago, Ill. (See ad.)  
Sweet & Doyle, Cohoes, N. Y. (See ad.)  
Thurston, A. G. & Son, Fall River,  
Mass.  
Watson, L. S., Mfg. Co., Leicester,  
Mass. (See ad.)  
Woodstock Hardwood & Spool Mfg. Co.,  
Charlestown, S. C. (See ad.)

**Multiple Sewing Machines.**

Fales, L. F., Walpole, Mass.

**Napping Machines.**

Columbia Napping Machine Co., Som-  
erville, Mass. (See ad.)  
Curtis & Marble Machine Co., Worces-  
ter, Mass. (See ad.)

Jones, Lewis, 60½ and Media Sts.,  
Phila., Pa.  
McCreary, E., Cohoes, N. Y. (See ad.)  
Parks & Woolson Machine Co., Spring-  
field, Vt. (See ad.)

**Neck Markers.**

Antidel, E. M., Utica, N. Y.  
Kennedy, Thos., Cohoes, N. Y.

**Noils, Silk.**

See page 378.

**Office Specialties.**

Niagara Clip Co., 123 Liberty St., New  
York.

**Oil Filters.**

Burt Mfg. Co., The, Akron, O.

**Oilless Bearings.**

Arguto Oilless Bearing Co., Wayne  
Junction, Phila., Pa.

**Oils.**

Houghton, E. F. & Co., Phila., Pa.  
New York Lubricating Oil Co., 35 Water  
St., New York.  
Oil Seeds Pressing Co., 15-25 Whitehall  
St., New York.  
Rodgers, David G., Paterson, N. J. (See  
ad.)

**Overseaming Machines.**

See Sewing Machines.

**Oxalic Acid.**

Rössler & Hasslacher Chemical Co.,  
100 William St., New York. (See ad.)

**Oxidizing Machinery.**

Hoag, A. W. & Co., Reading, Pa. (See  
ad.)

**Packing.**

Boston Belting Co., Boston, Mass.  
Coburn, Fred S., Woonsocket, R. I.  
(See ad.)  
Jenkins Bros., New York.

**Pantographs for Mill Engraving.**

Hope, John & Sons, Eng. & Mfg. Co.,  
Providence, R. I. (See ad.)  
Johnson, C. A. & Co., 22 Dey St., New  
York. (See ad.)

**Paper.**

Rodgers, David G., Paterson, N. J. (See  
ad.)

**Paper Tubes.**

Pairpoint Mfg. Co., New Bedford, Mass.  
(See ad.)

**Paper Boxes.**

Rosenberg, Henry, 107 Greene St., New  
York.

**Paper Cop Tubes.**

See Cop Tubes.

**Patent Solicitors.**

Crosby & Gregory, 31 School St., Bos-  
ton, Mass.  
Siggers, E. G., 918 F St., N. Y., Wash-  
ington, D. C.  
Wolhaupter, D. P., Equitable Bldg.,  
Washington, D. C.

**Perforated Copper.**

Beckley, A. J. & Co., Garwood, N. J.  
(See ad.)  
Phillips, Thomas Co., Providence, R. I.

**Perforated Metals.**

Beckley, A. J. & Co., Garwood, N. J.  
(See ad.)

**Peroxide of Sodium.**

Rössler & Hasslacher Chemical Co.,  
100 William St., New York. (See ad.)

**Picker Pins.**

Dodge, C. S., Lowell, Mass. (See ad.)

**Picker Sticks.**

See Mill Supplies.  
American Supply Co., Providence, R. I.  
(See ad.)  
Coburn, Fred S., Woonsocket, R. I.  
(See ad.)  
Southern Bobbin Co., Greensboro, S. C.

**Pins and Teeth.**

Crabb, William & Co., Newark, N. J.  
(See ad.)

**Pipe and Fittings.**

Coburn, Fred S., Woonsocket, R. I.  
(See ad.)

**Pipe Covering.**

Coburn, Fred S., Woonsocket, R. I.  
(See ad.)

Keasby, R. A., magnesia, 54 Warren St., New York.

**Plumbers' Supplies.**

Coburn, Fred S., Woonsocket, R. I.  
(See ad.)

**Pneumatic Conveying.**

See Ventilating.

**Portable Hoists.**

Larrabee John E., Amsterdam, N. Y.

**Power Transmitting Machinery.**

American Mfg. Co., 65 Wall St., New York.

American Tool & Machine Co., 100 Beach St., Boston, Mass.

Arguto Oilless Bearing Co., Wayne Junction, Phila., Pa.

Coburn, Fred S., Woonsocket, R. I.  
(See ad.)

Dodge Mfg. Co., Mishawaka, Ind.  
Eastern Machinery Co., New Haven, Conn. (See ad.)

Fairmount Machine Co., 22d and Wood Sts., Phila.

General Electric Co., 44 Broad St., New York. (See ad.)

Hoag, A. W. & Co., Reading, Pa. (See ad.)

Howard, Geo. C., Lansdowne, Pa., and 2123 Market St., Phila., Pa.

Hunt Rodney Machine Co., Orange, Mass. (See ad.)

Hunter, James, Machine Co., North Adams, Mass. (See ad.)

Jeffrey Mfg. Co., The, Columbus, O.

Kilbuck, Lincoln & Co., Fall River, Mass. (See ad.)

McCreary, E., Cohoes, N. Y. (See ad.)

New Process Raw Hide Co., Syracuse, N. Y.

Rusden Machine Co., Warren, R. I.

Saginaw Manufacturing Co., Saginaw, Mich.

Smith, Jas., Woolen Machy. Co., Phila., Pa. (See ad.)

Street, R. R. & Co., 184, 186 Washington St., Chicago, Ill. (See ad.)

Sweet & Doyle, Cohoes, N. Y. (See ad.)

**Preparatory Machinery (Cotton).**

Atherton, A. T., Mach. Co., Pawtucket, R. I. (See ad.)

Howard & Bullough Am. Machine Co., Pawtucket, R. I. (See ad.)

Klison Machine Co., Lowell, Mass. (See ad.)

Saco & Pettee Machine Shops, Newton Upper Falls, Mass. (See ad.)

**Press Boards and Feeders.**

Rogers, H. E., South Manchester, Conn.

**Presses.**

Boomer & Boschert Press Co., Syracuse, N. Y.

Butterworth, H. W. & Sons Co., Phila., Pa.

Curtis & Marble Machine Co., Worcester, Mass. (See ad.)

Hart, Chas., Frankford, Pa.

Howard, Geo. C., Lansdowne, Pa., and 2123 Market St., Phila., Pa.

Phillips Co., The Thomas, Providence, R. I.

Spence & Rideout, Nashua, N. H. (See ad.)

Sullivan Machinery Co., Claremont, N. H. (See ad.)

**Printing Machinery.**

See Dyeing, Bleaching and Finishing Machinery.

**Pulleys.**

See Power Transmitting Machinery.

**Pumps.**

Bamford & Smith, Pascoag, R. I. (See ad.)

Goulds Mfg. Co., Seneca Falls, N. Y.

Rusden Machine Co., Warren, R. I.

**Purifying and Filtration Plants.**

Automatic Water Purifying Co., 45 Broadway, New York.

Scaife, W. B. & Sons, Pittsburg, Pa.

**Quillers.**

Fairmount Machine Co., Phila.

Lever, Oswald, Lehigh Ave. and Mascher St., Philadelphia, Pa.

Payne, G. W. Co., Pawtucket, R. I. (See ad.)

**Rag Pickers.**

Dodge, C. S., Lowell, Mass. (See ad.)

Smith, James, Woolen Machinery Co., Phila., Pa. (See ad.)

**Rags.**

See page 403.

**Raw Hide Gears.**

New Process Raw Hide Co., Syracuse, N. Y.

**Reed and Harness Manufacturers.**

American Supply Co., Providence, R. I. (See ad.)

Crabb, William & Co., Newark, N. J. (See ad.)

Emmons Loom Harness Co., Lawrence, Mass. (See ad.)

Street, R. R. & Co., 184, 186 Washington St., Chicago, Ill. (See ad.)

Walder, J., Paterson, N. J.

**Ribbons.**

Barton, F. C., 54 Franklin St., New York.

Cheney Bros., S. Manchester, Ct. (See ad.)

Friedberger Mfg. Co., Germantown, Pa. (See ad.)

**Ring Travelers.**

American Supply Co., Providence, R. I. (See ad.)

DeHaven Mfg. Co., 50 Columbia Heights, Brooklyn, N. Y. (See ad.)

National Ring Traveler Co., Providence, R. I.

Shaw, Victor, Ring Traveler Co., Providence, R. I.

**Roll Covers.**

North Chelmsford Supply Co., North Chelmsford, Mass. (See ad.)

**Rolls.**

Getchell, S. S. & Son, Woonsocket, R. I. (See ad.)

**Roller Cloths.**

See Mill Supplies.

**Roller Skins.**

English, C. R. Co., 301 Congress St., Boston. (See ad.)

Houghton, E. F. & Co., Phila., Pa.

**Roofing, Iron.**

See Iron Buildings and Roofing.

**Rope.**

American Mfg. Co., 65 Wall St., New York.

**Rope Transmission.**

American Mfg. Co., 65 Wall St., New York.

Dodge Mfg. Co., Mishawaka, Ind.

Street, R. R. & Co., 184, 186 Washington St., Chicago, Ill. (See ad.)

**Rotary Presses.**

See Presses.

**Roving Cans.**

Hill Jas., Mfg. Co., Providence, R. I. (See ad.)

- Laminar Fibre Co., North Cambridge, Mass.  
N. E. Ventilating & Heating Co., 930 Manton Ave., Providence, R. I.  
Spaulding-Perkins Co., No. Rochester, N. H. (See ad.)  
Wairus Fibre Mfg. Co., No. Cambridge, Mass.
- Rubber Covered Rollers and Goods.**  
Boston Belting Co., Boston, Mass.
- Saddles, Stirrups and Levers.**  
Dixon Lubricating Saddle Co., Bristol, R. I.
- Sample Cards.**  
Merchants Sample Card Co., 33 Sullivan St., New York.  
Steinthal, M. & Co., 267 W. Broadway, New York. (See ad.)  
Rosenberg, Henry, 107 Greene St., N. Y.
- Sample Cutter.**  
Steinthal, M. & Co., 267 W. Broadway, New York. (See ad.)
- Sample Mounting.**  
Merchants Sample Card Co., 33 Sullivan St., New York. (See ad.)  
Rosenberg, Henry, 107 Greene St., N. Y.  
Steinthal, M. & Co., 267 W. Broadway, New York. (See ad.)
- Scales.**  
Sweet & Doyle, Cohoes, N. Y. (See ad.)
- Scallop Machines.**  
Merrow Machine Co., Hartford, Conn.
- Schools.**  
American Correspondence School, Boston, Mass. (See ad.)  
International Correspondence School, Scranton, Pa.  
Lowell Textile School, Lowell, Mass.  
New Bedford Textile School, New Bedford, Mass.  
Philadelphia Textile School, Phila.
- Screening.**  
See also Perforated Metals.  
Beckley, A. J. & Co., Garwood, N. J. (See ad.)
- Separators.**  
Draper Co., The, Hopedale, Mass. (See ad.)  
Ring Frame Thread Protector Co., The, Amsterdam, N. Y.
- Sewing Machines and Supplies.**  
Arlington Machine Works, Arlington Heights, Mass.  
Arnold Sewing Machine Co., 216 High St., Newark, N. J.  
Birch Bros., Somerville, Mass. (See ad.)  
Curtis & Marble Machine Co., Worcester, Mass. (See ad.)  
Dinsmore Mfg. Co., Salem, Mass.  
Fales, L. F., Walpole, Mass. (See ad.)  
Krusc & Murphy Mfg. Co., 455-57 W. 26th St., New York. (See ad.)  
Manufacturers' Supplies Co., 66 No. 4th St., Phila., Pa.  
Merrow Machine Co., Hartford, Conn.  
Rusden Machine Co., Warren, R. I.  
Scott & Williams, 2079 E. Cumberland St., Phila.  
Street, R. R. & Co., 184, 186 Washington St., Chicago, Ill. (See ad.)  
Union Button Sewing Machine Co., 164 High St., Boston, Mass.  
Union Special Sewing Machine Co., 47 Leonard St., New York. (See ad.)  
Von Buchwald, W. J., 120 N. 7th St., Phila., Pa.  
Willcox & Gibbs Sewing Machine Co., 638 Broadway, New York.
- Shafting.**  
See Power Transmitting Machinery.
- Shearing Machinery.**  
See Dyeing, Drying, Bleaching and Finishing.
- Shell Rolls.**  
Cohoes Foundry & Machine Co., Cohoes, N. Y.  
Riley, C. E. & Co., 231 Congress St., Boston. (See ad.)  
Thurston, A. G. & Son, Box 528, Fall River, Mass.
- Shoddies.**  
See page 397.
- Shoddy Pickers.**  
Dodge, C. S., Lowell, Mass. (See ad.)
- Shooks.**  
See Box Shooks.
- Shuttle Checks.**  
Victor Shuttle Check Co., Auburn, N. Y.
- Shuttles.**  
See Bobbins, Spools, Shuttles, etc.
- Silk Machinery.**  
Butterworth, H. W., & Sons Co., Phila.  
Crompton & Knowles Loom Works, Worcester, Mass. (See ad.)  
Granger Foundry & Machine Co., Providence, R. I.  
Kilburn, Lincoln & Co., Fall River, Mass. (See ad.)  
Mason Machine Works, Taunton, Mass. (See ad.)  
Rusden Machine Co., Warren, R. I.
- Singling Machines.**  
Arlington Machine Works (Arthur Birch), Arlington Heights, Mass.  
Birch Bros. (Albert Birch), Somerville, Mass. (See ad.)  
Butterworth, H. W., & Sons Co., Phila., Pa.  
Curtis & Marble Machine Co., Worcester, Mass. (See ad.)  
Granger Foundry & Machine Co., Providence, R. I.  
Rusden Machine Co., Warren, R. I.
- Singe Plates.**  
Butterworth, H. W., & Sons Co.  
Taunton-New Bedford Copper Co., New Bedford, Mass. (See ad.)
- Sizing, Starch and Gums.**  
Arabel Mfg. Co., New York.  
Elwell, Henry A. & Co., 5 No. Front St., Philadelphia, Pa.  
O. K. Soap Co., 968 Franklin St., Phila., Pa.  
Stein, Hirsh & Co., 165 Duane St., N. Y. (See ad.)
- Slasher Combs.**  
Emmons Loom Harness Co., Lawrence, Mass. (See ad.)
- Slashers.**  
Cohoes Foundry & Machine Co., Cohoes, N. Y.  
Howard & Bullough, American Machine Co., Pawtucket, R. I. (See ad.)  
Lowell Machine Shop, Lowell, Mass. (See ad.)  
Phillips, Thomas Co., Providence, R. I.
- Smoke Prevention.**  
Steam Boiler Equipment Co., 20 W. Houston St., New York.
- Soaps.**  
Hollbrook Mfg. Co., 466 Washington St., New York. (See ad.)  
India Alkali Works, Boston.  
O. K. Soap Co., 968 Franklin St., Philadelphia, Pa.
- Spindles.**  
Bamford & Smith, Pascoag, R. I. (See ad.)  
Buckley, Benj., Sons, Gun Mill, Paterson, N. J.  
Draper Company, Hopedale, Mass. (See ad.)  
Easton & Burnham Machine Co., Pawtucket, R. I.



- Payne, G. W., & Co., Pawtucket, R. I.  
(See ad.)
- Ward & Vandegrift, Elmer, N. J.  
Whitin Machine Works, Whitinsville,  
Mass. (See ad.)
- Spindle Tubes, Worsted.**  
Bamford & Smith, Pascoag, R. I. (See  
ad.)
- Spinning Cylinders.**  
Arguto Oilless Bearing Co., Wayne  
Junction, Pa.  
Hill, Jas. Mfg. Co., Providence, R. I.  
(See ad.)  
N. E. Ventilating & Heating Co., 330  
Manton Ave., Providence, R. I.
- Spinning Frames.**  
See Cotton Machinery.
- Spinning Rings.**  
Draper Company, Hopedale, Mass.  
(See ad.)  
Whitinsville Spinning Ring Co., Whit-  
insville, Mass. (See ad.)
- Spinnings' Supplies.**  
Dixon Lubricating Saddle Co., Bristol,  
R. I.
- Spinning Tubes.**  
Bamford & Smith, Pascoag, R. I. (See  
ad.)  
Buckley, Benj., Son, Gun Mill, Pater-  
son, N. J.
- Spooler-knotter.**  
Barber & Coleman, 11 Pemberton  
Square, Boston, Mass. (See ad.)
- Spoolers.**  
Draper Company, Hopedale, Mass.  
(See ad.)  
Easton & Burnham Machine Co., Paw-  
tucket, R. I.  
Furbush, M. A. & Son, Machine Co.,  
Camden, N. J. (See ad.)  
Lever, Oswald, Lehigh Ave. and Mas-  
cher St., Phila.  
Payne, G. W., & Co., Pawtucket, R. I.  
(See ad.)  
Saco & Pettee Machine Shop, Newtoh  
Upper Falls, Mass. (See ad.)
- Spools.**  
See also Bobbins, Spools and Shuttles.  
Sweet & Doyle, Cohoes, N. Y. (See ad.)  
McGuire, The John A. Co., Claremont,  
N. H.  
Murray, Chas. O., Nashua, N. H. (See  
ad.)  
Tebbetts, E. L. & Co., Locke's Mills,  
Me. (See ad.)
- Sprinklers.**  
International Sprinkler Co., Philadel-  
phia, Pa.
- Stamps and Ink.**  
Yenlo Co., The, York, Pa. (See ad.)  
Sweet & Doyle, Cohoes, N. Y. (See ad.)
- Stamps for Hosiery.**  
Atlas Copper Stamp Works, 15 White-  
hall St., New York.  
Wells, Willfred, 505 W. Lehigh Ave.,  
Phila, Pa.  
Yenlo Co., The, York, Pa. (See ad.)
- Starch.**  
See Sizing, Starch and Gums.
- Steam Boiler Insurance.**  
Hartford Steam Boiler Inspection &  
Insurance Co., Hartford, Conn.  
(See ad.)
- Steam Boilers.**  
Eabcock & Wilcox Co., 29 Cortlandt  
St., New York. (See ad.)  
Brown, C. H., Co., Fitchburg, Mass.  
Street, R. R. & Co., 184, 186 Washing-  
ton St., Chicago, Ill. (See ad.)
- Steam Engines.**  
American Flower Co., Detroit, Mich.  
Brown, C. H., & Co., Fitchburg, Mass.  
Buffalo Forge Co., Buffalo, N. Y.  
Hooven, Owens & Rentsler, The, Co.,  
Hamilton, O.  
Leffel, Jas., & Co., Springfield, O.  
Rusden Machine Co., Warren, R. I.  
Street, R. R. & Co., 184, 186 Washing-  
ton St., Chicago, Ill. (See ad.)  
Sturtevant, B. F. Co., Jamaica Plain  
Station, Mass.
- Steam Specialties.**  
Butterworth, H. W. Sons Co., Phila.,  
Pa.  
Houghton, E. F. & Co., Phila., Pa.  
Jenkins Bros., New York.  
Rusden Machine Co., Warren, R. I.  
Steam Boiler Equipment Co., 20 W.  
Houston St., New York.  
Sterling Blower & Pipe Mfg. Co., The,  
Hartford, Conn.  
Sturtevant Co., B. F., Boston.
- Steam Surface Coverings.**  
Coburn, Fred S., Woonsocket, R. I.  
(See ad.)  
Keasby, R. A., 54 Warren St., New  
York.
- Steam Traps.**  
Houghton, E. F. & Co., Phila., Pa.  
Sturtevant, B. F., Co., Jamaica Plain  
Station, Mass.
- Steam Valves.**  
Jenkins Bros., New York.
- Stencils.**  
See Stamps and Stencils.
- Stop Motion for Knitting Machines.**  
Nye & Tredick, 606 Arch St., Phila., Pa.
- Stop Motion for Looms.**  
See also Warp Stop Motions.  
Tucker Stop Motion Co., Hartford,  
Conn. (See ad.)
- Tanks, Tubs and Vats.**  
Caldwell, W. E., Co., 202 Brook St.,  
Louisville, Ky. (See ad.)  
Cypress Lumber Co., Apalachicola, Fla.  
Davis, G. M. & Son, Palatka, Fla.  
Hoag, A. W. & Co., Reading, Pa. (See  
ad.)  
Lewis, H. F. & Co., New Orleans, La.  
Rusden Machine Co., Warren, R. I.  
Stearns, A. T., Lumber Co., Neponset,  
Mass. (See ad.)  
Stevens, D. B. & Co., Auburn, Me.  
Thompson, Jas. A., Lowell, Mass. (See  
ad.)  
Woolford, Geo., Tank & Vat Mfg. Co.,  
Real Estate Trust Bldg., Phila.
- Tapes, Braids and Cords.**  
Barton, F. C., 54 Franklin St., New  
York.  
Cathcart, John & Co., 115 Franklin St.,  
New York. (See ad.)  
Chapin, Geo. W., 229 Church St., Phila.,  
Pa. (See ad.)  
Eddy & Street, Providence, R. I. (See  
ad.)  
Friedberger Mfg. Co., Germantown,  
Pa. (See ad.)  
Goff, D. & Sons, Pawtucket, R. I. (See  
ad.)  
Hamilton, J. H. & Co., 84 Franklin St.,  
New York.  
Kroul & Pite Mfg. Co., Allegheny Ave.  
and Emerald St., Philadelphia, Pa.  
(See ad.)  
Steinthal, M., & Co., 9 Moore St., New  
York. (See ad.)  
Street, R. R. & Co., 184, 186 Washington  
St., Chicago, Ill. (See ad.)  
Weimer Bros., Hope and Huntington  
Sts., Phila.  
Young, W. M., 2421 Washer St., Phila.,  
Pa. (See ad.)

**Temples.**

Draper Company, Hopedale, Mass. (See ad.)

**Tentering Machines.**

See Dyeing, Bleaching Machinery, etc.

**Tension Pulleys.**

Arguto Oilless Bearing Co., Wayne Junction, Phila., Pa.  
N. E. Ventilating & Heating Co., 930 Manton Ave., Providence, R. I.

**Tenter Clips.**

See Dyeing, Drying, Bleaching and Finishing Machinery.

**Testing Machines.**

Burke & Hanford, 621 Broadway, N. Y.  
Howard, Geo. C., Lansdowne, Pa. and 2123 Market St., Phila., Pa.

**Thermometers.**

Riggs & Bros., 310 Market St., Phila., Pa. (See ad.)

**Thread Board for Spinning and Twisting Frames.**

Houghton, L. T., Worcester, Mass.

**Thread Protectors.**

Ring Frame Thread Protector Co., The, Amsterdam, N. Y.

**Tower Clocks.**

Howard, E. Clock Co., The, 403 Washington St., Boston. (See ad.)

**Traveler Cups.**

Whitinsville Spinning Ring Co., Whitinsville, Mass. (See ad.)

**Travelers (Spinning and Twisting).**

DeHaven Mfg. Co., 50 Columbia Heights, Brooklyn, N. Y. (See ad.)  
National Ring Traveler Co., Providence, R. I.  
Shaw, Victor Ring Traveler Co., Providence, R. I.

**Trimmers.**

Arnold Sewing Machine Co., Newark, N. J.  
Krusse & Murphy Mfg. Co., 455 West 26th St., N. Y.  
Union Special Sewing Machine Co., New York and Chicago. (See ad.)  
Von Buchwald, W. C., 129 N. 7th St., Phila., Pa. (See ad.)  
Willcox & Gibbs Sewing Machine Co., 658 Broadway, New York.

**Trimmings.**

See Knit Goods, Edgings, Trimmings, etc.

**Trucks.**

Laminar Fibre Co., North Cambridge, Mass.  
Lane, W. T. & Bro., Port Chester, N. Y. (See ad.)  
Spaulding-Perkins Co., No. Rochester, N. H. (See ad.)  
Walrus Fibre Mfg. Co., No. Cambridge, Mass.

**Tubes.**

Pairpoint Mfg. Co., New Bedford, Mass. (See ad.)

**Turbine Governor.**

Cohoes Foundry & Machine Co., Cohoes, N. Y.  
Replogle Governor Works, Akron, Ohio. (See ad.)

**Turbines.**

See Water Wheels.

**Twine.**

American Mfg. Co., 62-65 Wall St., New York.

**Twine Machinery.**

Brownell, G. L., Worcester, Mass.

Bullcock, O. S., Machine Co., Cambridge, Mass. (See ad.)

**Twisting Machinery.**

Brownell, G. L., Worcester, Mass.  
Bullcock, O. S., Machine Co., Cambridge, Mass. (See ad.)

**Valves.**

Coburn, Fred S., Woonsocket, R. I. (See ad.)  
Jenkins Bros., New York.

**Valves (Rubber)**

Boston Belting Co., Boston, Mass.

**Ventilating Apparatus.**

Allington & Curtis Mfg. Co., 29 Otis St., East Cambridge, Mass.  
American Air Moistening Co., Boston.  
American Blower Co., Detroit, Mich.  
Berry, A. Hun, 23 W. 1st St., Boston. (See ad.)  
Boston Blower Co., Hyde Park, Mass.  
Buffalo Forge Co., Buffalo, N. Y.  
Hartford Blower Co., Hartford, Conn. (See ad.)  
Manhattan Machine Supply Co., 106 Grand St., New York.  
Massachusetts Fan Co., Waltham, Mass.  
N. E. Heating & Ventilating Co., Providence, R. I.  
Phila. Drying Machinery Co., 6721 Germantown Ave., Philadelphia, Pa. (See ad.)  
Philadelphia Textile Machinery Co., Hancock St., above Lehigh Ave., Phila. (See ad.)  
Sargent's C. G., Sons, Graniteville, Mass. (See ad.)  
Sterling Blower & Pipe Mfg. Co., Hartford, Conn.  
Sturtevant, B. F., & Co., Jamaica Plain Station, Mass.

**Ventilating Fans.**

See Ventilating Apparatus.

**Warp Stop Motions.**

Draper Co., Hopedale, Mass. (See ad.)

**Washers (Cloth).**

Arlington Machine Works (Arthur Birch) Arlington Heights, Mass.  
Birch Brothers (Albert Birch), Somerville, Mass. (See ad.)  
Butterworth, H. W. & Sons Co., Phila., Pa.  
Hunt, Rodney, Machine Co., Orange, Mass. (See ad.)  
Hunter, Jas., Machine Co., No. Adams, Mass. (See ad.)  
Kenyon, D. R. & Son, Raritan, N. J.  
Phillips Co., The Thomas, Providence, R. I.  
Rusden Machine Co., Warren, R. I.  
Street, R. R. & Co., 184, 186 Washington St., Chicago, Ill. (See ad.)

**Washing Soda.**

Ford, J. B. Co., Wyandotte, Mich. (See ad.)

**Waste.**

Allison, G. F., & Co., Utica, N. Y. (See ad.)  
Becker, Charles W., Amsterdam, N. Y. (See ad.)  
Charles, William B., Amsterdam, N. Y. (See ad.)  
Connell, John J., 239 N. Front St., Philadelphia, Pa. (See ad.)  
Hayes, John J. & Co., 47 North Front St., Phila. (See ad.)  
Lampart Manufacturers' Supply Co., 87 Eldridge St., New York. (See ad.)  
Lowenthal, W. & Co., Cohoes, N. Y. (See ad.)

- Lyon, J. H. & Co., 174 Duane St., New York. (See ad.)
- Reis & Co., 620 Atlantic Ave., Boston. (See ad.)
- Wolf, W., & Sons, 620 Atlantic Ave., Boston, Mass. (See ad.)
- Watchmen's Clocks.**
- Eco Magneto Co., 620 Atlantic Ave., Boston. (See ad.)
- Howard, E. Clock Co., The, 403 Washington St., Boston. (See ad.)
- Nanz & Co., New York.
- Newman Clock Co., 501 Masonic Temple, Chicago, Ill. (See ad.)
- Riggs & Bros., 310 Market St., Phila., Pa. (See ad.)
- Water Purifiers and Filters.**
- Automatic Water Purifying Co., 45 Broadway, New York.
- Norwood Engineering Co., Florence, Mass. (See ad.)
- Scaife, W. B. & Sons, Pittsburg, Pa.
- Water Towers.**
- Caldwell, W. E., Co., 202 Brook St., Louisville, Ky. (See ad.)
- Water Wheel Governors.**
- Cohoes Foundry & Machine Co., Cohoes, N. Y.
- Leffel, James & Co., Springfield, Ohio.
- Replogle Governor Works, Akron, Ohio. (See ad.)
- Water Wheels.**
- Hunt, Rodney, Machine Co., Orange, Mass. (See ad.)
- Leffel, James, & Co., Springfield, O.
- Wind Mills.**
- Caldwell, W. E., Co., 202 Brook St., Louisville, Ky. (See ad.)
- Winder Bobbins.**
- Payne, Geo. W. & Co., Pawtucket, R. I. (See ad.)
- Sweet & Doyle, Cohoes, N. Y. (See ad.)
- Winders (Back).**
- Taylor, Jas., 835 Arch St., Phila., Pa.
- Winders (Cloth).**
- McCreary, E., Cohoes, N. Y. (See ad.)
- Parks & Woolson Machine Co., Springfield, Vt. (See ad.)
- Winders (Hosiery).**
- Altemus, Jacob K., 2824 North 4th St., Phila. (See ad.)
- Foster Machine Co., Westfield, Mass. (See ad.)
- Howard & Bullough, American Machine Co., Pawtucket, R. I. (See ad.)
- Lever, Oswald, Lehigh Ave. and Mascher St., Phila.
- Lindley, G. W., Germantown, Pa. (See ad.)
- Payne, G. W., & Co., Pawtucket, R. I. (See ad.)
- Snyder, Homer P., Mfg. Co., Little Falls, N. Y.
- Universal Winding Co., 226 Devonshire St., Boston. (See ad.)
- Winding Machines.**
- Altemus, W. W. & Son, 2824 North 4th St., Phila. (See ad.)
- Fairmount Machine Co., Phila., Pa.
- Foster Machine Co., Westfield, Mass. (See ad.)
- Lever, Oswald, Lehigh Ave. and Mascher St., Phila.
- Universal Winding Co., 226 Devonshire St., Boston. (See ad.)
- Wire Goods (Factory).**
- DeHaven Mfg. Co., 50 Columbia Heights, Brooklyn, N. Y. (See ad.)
- Dixon Lubricating Saddle Co., Bristol, R. I.
- Wood Pulleys.**
- Chase Pulley Co., Providence, R. I.
- Coburn, Fred S., Woonsocket, R. I. (See ad.)
- Dodge Mfg. Co., Mishawaka, Ind.
- Hoag, A. W. & Co., Reading, Pa. (See ad.)
- McCreary, E., Cohoes, N. Y. (See ad.)
- Saginaw Manufacturing Co., Saginaw, Mich.
- Wool.**
- See also page 406.
- Charles, William B., Amsterdam, N. Y. (See ad.)
- Collings, Taylor & Co., Cleveland, O. (See ad.)
- Connell, John J., 239 N. Front St., Philadelphia, Pa. (See ad.)
- Swift Wool Company, Hatchway Bldg., Boston. (See ad.)
- Willett, G. F., & Co., 117 Federal St., Boston. (See ad.)
- Wool and Waste Dusters.**
- Atlas Foundry & Machine Co., Belleville, N. J.
- Gerry, Geo., & Son, Athol, Mass.
- Sargent's, C. G., Sons, Graniteville, Mass. (See ad.)
- Smith, James Woolen Machinery Co., Phila., Pa. (See ad.)
- Street, R. R., & Co., 184, 186 Washington St., Chicago, Ill. (See ad.)
- Wool Cleaning Compound.**
- Ford, J. B. Co., Wyandotte, Mich. (See ad.)
- Thayer, E. M. & Co., Boston, Mass.
- Wool Combs.**
- See Combs, Circles and Fallers.
- Wool Combing Machinery.**
- Crompton & Knowles Loom Works, Worcester, Mass. (See ad.)
- Jefferson, Ed. & Bros., 28 Strawberry St., Phila., Pa.
- Leign, Evan Arthur, 35-36 Mason Bldg., Boston, Mass. (See ad.)
- Riley, C. E., & Co., 21 Congress St., Boston. (See ad.)
- Wool Dryers.**
- See Dryers.
- Woolen Machinery.**
- Altemus, Jacob K., 2824 N. 4th St., Phila. (See ad.)
- American Tool & Machine Co., Boston, Mass.
- Arguto Oilless Bearing Co., Wayne Junction, Phila., Pa.
- Arlington Machine Works (Arthur Birch), Arlington Heights, Mass.
- Atlas Foundry & Machine Co., Belleville, N. J.
- Birch Bros. (Albert Birch), Somerville, Mass. (See ad.)
- Butterworth, H. W., & Sons Co., Phila.

Brushed and Scoured **Pulled Wool**

**Swift & Company**

Eastern Offices 620 Atlantic Avenue, Boston  
107 Chestnut St., Philadelphia  
1006 Wool Exchange, N. Y. City

Union Stock Yards, Chicago—Samples Sent on Application

- Crompton & Knowles Loom Works, Worcester, Mass. (See ad.)  
 Curtis & Marble Machine Co., Worcester, Mass. (See ad.)  
 Fairmount Machine Co., 22d and Wood Sts., Phila.  
 Fales, L. F., Walpole, Mass. (See ad.)  
 Furbush, M. A., & Son Machine Co., Camden, N. J. (See ad.)  
 Howard, Geo. L., Lansdowne, Pa. and 2123 Market St., Phila., Pa.  
 Hunt, Rodney Machine Co., Orange, Mass. (See ad.)  
 Hunter, Jas., Machine Co., No. Adams, Mass. (See ad.)  
 Kenyon, D. R. & Son, Raritan, N. J.  
 Leigh, Evan Arthur, 35-36 Mason Bldg., Boston, Mass. (See ad.)  
 Lever, Oswald, Lehigh Ave. and Mascher St., Phila.  
 Lowe, Stephen C., Boston, Mass. (See ad.)  
 Parks & Woolson Machine Co., Springfield, Vt. (See ad.)  
 Phila. Drying Machinery Co., 6721 Germantown Ave., Philadelphia, Pa. (See ad.)  
 Philadelphia Textile Machinery Co., Hancock & Somerset Sts., Phila. (See ad.)  
 Phillips Co., The Thomas, Providence, R. I.  
 Riley, C. E., & Co., 281 Congress St., Boston, Mass. (See ad.)  
 Rusden Machine Co., Warren, R. I.  
 Sargent's, C. G., Sons, Graniteville, Mass. (See ad.)  
 Schofield, Geo. L., Phila., Pa.  
 Smith, James Woolen Machinery Co., Phila., Pa. (See ad.)  
 Street, R. R., & Co., 184, 186 Washington St., Chicago, Ill. (See ad.)
- Woolen Rags.**  
 See page 493.
- Woolen Yarns.**  
 See Yarn Index, page 353.
- Wool Extracts.**  
 See page 397.
- Wool Oils.**  
 See Oils.
- Wool Scourers and Sorters.**  
 See page 386.
- Wool Shoddies.**  
 See page 397.
- Wool Washing, Preparing and Drying Machinery.**  
 Atlas Foundry & Machine Co., Belleville, N. J.  
 Hunter, Jas., Machine Co., No. Adams, Mass. (See ad.)  
 Phila. Drying Machinery Co., 6721 Germantown Ave., Philadelphia, Pa. (See ad.)  
 Philadelphia Textile Mach. Co., Hancock & Somerset Sts., Phila. (See ad.)  
 Phillips Co., The Thomas, Providence, R. I.  
 Sargent's, C. G., Sons, Graniteville, Mass. (See ad.)  
 Smith, James Woolen Machinery Co., Phila., Pa. (See ad.)  
 Street, R. R., & Co., 184, 186 Washington St., Chicago, Ill. (See ad.)
- Worsted Machinery.**  
 Crompton & Knowles Loom Works, Worcester, Mass. (See ad.)  
 Furbush, M. A., & Son Machine Co., Camden, N. J. (See ad.)  
 Jefferson, Edward & Bros., 28 Strawberry St., Philadelphia, Pa.  
 Leigh, Evan Arthur, 35-36 Mason Bldg., Boston, Mass. (See ad.)  
 Lowell Machine Shop, Lowell, Mass. (See ad.)  
 Parks & Woolson Machine Co., Springfield, Vt. (See ad.)  
 Riley, C. E., & Co., 281 Congress St., Boston. (See ad.)
- Yarn Printers.**  
 See page 396.
- Yarn Raveling Machines.**  
 Taylor, James, 835 Arch St., Philadelphia, Pa.
- Yarns, Threads, etc.**  
 See Classified Lists in Yarn Department on page 353.

## LOCKWOOD, GREENE & CO.

# Architects AND Engineers

ENTIRE SIXTH FLOOR

93 FEDERAL STREET, - - BOSTON.

Textile Plants.      Water Power.      Finishing Plants.      Steam Power.  
 Industrial Plants.      Electric Power.      Reports and Valuations.

### ADOLPH SUCK, MILL ARCHITECT AND ENGINEER,

Plans and Specifications for Construction of Cotton, Woolen and other  
 Textile Mills. Remodeling of Old Plants a Specialty.

179 SUMMER ST., BOSTON, MASS.

# ARTHUR F. GRAY,

Mill Engineer and Architect.

## COTTON MILLS A SPECIALTY.



Power Plants for Steam, Water or Electric  
Development. Valuation of Mill Properties.

509 EXCHANGE BLDG. **BOSTON, MASS.** 53 STATE STREET.

W. B. Smith Whaley, M. E.  
A. S. M. E.

Gadsden E. Shand,  
Arch. & C. E.

*W. B. Smith Whaley & Co.*  
Mill Engineers and Architects,

Boston, Mass.

Columbia, S. C.

1012 Tremont Building.

1328 Main Street.

Plans and Specifications Prepared for all kinds of  
Manufacturing Plants.

Electrical Transmission in Textile Mills a Specialty.

# Alphabetical Index to Advertisers.

Allison, G. F. & Co.....	189	Dodge, C. S.....	399
Altemus, Jacob K.....	18	Dodge Needle Co.....	457
American Card Clothing Co.....	24	Draper Co. ....	3, 4, 5
American Cotton Yarn Exchange.....	389	Dubois, A. N.....	36
American School of Correspondence.....	348	Eastern Machinery Co.....	28
American Supply Co...Inside front cover		Eddy & Street.....	371
American Yarn Printing Works.....	396	Emmons Loom Harness Co.....	22
Atherton, A. T. Machine Co.....	47	English, C. R.....	25
Babeock & Wilcox Co.....	459	Fabric Measuring & Packaging Co....	175
Bailey, Frank .....	35	Farbenfabriken of Elberfeld Co .....	34
Bamford & Smith.....	351	Fales, L. F.....	458
Barber & Colman.....	352	Fawcett, Hughes .....	377
Beattie's Machine Works.....	456	Ford, The J. B. Co.....	38
Becker, Charles W.....	400	Foster, J. R. & Sons.....	388
Beckley, A. J. & Co.....	27	Foster Machine Co.....	462
Berlin Aniline Works.....	34	Friedberger Mfg. Co.....	64
Berry, A. Hun.....	1	Furbush, M. A. & Son Machine Co....	16
Birch Bros. ....	32	General Electric Co.....	17
Blanding, C. L., Mfg. Co.....	286	Getchell, S. S. & Son.....	187
Blythe, Richard A.....	63	Goff, D. & Sons.....	374
Booth, Benj. & Co., Ltd.....	27	Grant Yarn Co.....	367
Dosson & Lane.....	37	Gray, Arthur F.....	61
Boyer, B. F. Co.....	374	Greene & Daniels Mfg. Co.....	366
Brantley, A. P. Co.....	411	Hampton Co.....	369
Breedon's, Wm. Son.....	456	Harper, E. G.....	377
Brinton, H. & Co.....	452	Harris, T. A. & Co.....	391
Buckingham, Paulson & Co.....	380	Hartford Blower Co., The.....	459
Bullock, O. S. Machine Co.....	26	Hartford Steam Boiler Inspection & Insurance Co.....	27
Burton, Andrew .....	392	Hawes Bros. & Blythe.....	380
Eyram, F. A.....	377	Hayes, John J. & Co.....	351
Caldwell, W. E. Co.....	37	Hill, James, Mfg. Co.....	21
Campion, Richard .....	377	Hoag, A. W. & Co.....	32
Cassella Color Co.....	35	Holbrook Mfg. Co.....	384
Cathcart, Jenn & Co.....	378	Hollis, R. H.....	429
Catlin & Co.....	354	Holmes, John C. & Co.....	393
Champlain Silk Mills.....	379	Hooper Sons Mfg. Co.....	428
Chapin, Geo. W.....	383	Hope, John, & Sons Engraving & Manufacturing Co. ....	355
Charles, William B.....	383, 400	Howard & Bullough American Ma- chine Co.....	9
Charleston Export & Commission Co.	419	Howard, E. Cloek Co.....	351
Cheney Bros.....	383	Hulton, James & Bros.....	393
Coburn, Fred S.....	24	Hunt, Rodney Machine Co.....	13
Collings, Taylor & Co.....	398	Hunter, James, Machine Co.....	12
Columbia Napping Machine Co.....	16	Indian Orchard Co.....	370
Connell, John J.....	402	Ives, Loyal T.....	457
Cook, Stephen S.....	456	Jenckes, E. Mfg. Co.....	396
Corey, S. J.....	37	Johnson, Chas. A. & Co.....	32
Coupe, Wm. & Co.....	25	Johnson, Thomas .....	217
Crabb, William & Co.....	23	Kagermann, E. ....	392
Crane Mfg. Co.....	454	Keller John J. & Co.....	33
Cranston Worsted Mills.....	374	Kelly, Benj. F. & Son.....	38
Craw, J. W., Laundry Machinery Co.	458	Keystone Knitting Machine Mfg. Co.,	456
Crompton & Knowles Loom Works...	42	Kilburn-Lincoln & Co.....	7
Curtis & Marble Machine Co.....	16	Kitson Machine Co.....	44
Dana Warp Mill.....	364	Klauder-Weldon Dyeing Machine Co.	29
Davidson & Brooke.....	393	Klipstein, A. & Co.....	37
De Haven Mfg. Co.....	385	Koehl, Victor & Co.....	33
Delahanty Dyeing Machine Co.....	29	Krout & Fite Mfg. Co.....	383
Dempsey, J. C. & Co.....	35	Kruse & Murphy Mfg. Co.....	452
Denny, R. B. & Co.....	410	Kuttruff, Pickhardt & Co.....	109
De Veer, H.....	378		
Dillon & Co.....	33		
Dodds, J. S.....	368		

Lampport Manufacturers' Supply Co...	402	Riverdale Woolen Co.....	399
Lane, W. T. & Bro.....	459	Robbins, O. A.....	267
Lawton Spinning Co.....	360	Roessler & Hasslacher Chemical Co..	36
Leigh, Evan Arthur.....	25	Rodgers, D. G.....	23
Leighton Machine Co.....	452	Rossendale, Reddaway Belting & Hose Co.....	32
Lindley, Geo W.....	454	Rowland, Samuel .....	359
Linnehan, J. W. & Co.....	33	Saco & Pettee Machine Shops.....	48
Livermore, Homer F.....	18	Salkeld, A. D. & Bro.....	371
Lockwood, Greene & Co.....	60	Sargent's, C. G., Sons.....	19
Lorimer, John H.....	390	Sharpless Dyewood Extract Co.....	35
Lorimer's, The Wm. H. Sons Co...368,	392	Skenandoa Cotton Co.....	356
Lowe, Stephen C.....	10	Skerry, A. T. & Co.....	374
Lowell Crayon Co.....	26	Slack, W. H. H. & Bro.....	400
Lowell Machine Shop.....	2	Smith, James, Woolen Machinery Co.	14
Lowenthal, W. & Co.....	400	Spaulding-Perkins Co. ....	20
Luithlen, L. B.....	391	Spence & Rideout.....	453
Lyon, John H. & Co.....	402	Stafford & Holt.....	454
Maddock, Richard C.....	450	Stearns, A. T. Lumber Co.....	37
Mason Brush Works.....	24	Stein, Hirsh & Co.....	384
Mason Machine Works.....	6	Steinthal, M. & Co.....	421
McCreary, Edward .....	453	Stoughton Mills .....	401
McMichael & Wildman.....	454	Street, R. R. & Co.....	346
Mechling Bros. Mfg. Co.....	346	Suck, Adolph .....	60
Mitchell, James E. & Co.....	380	Sullivan Machinery Co.....	4, 12
Molt Bros. ....	125	Sweet & Doyle.....	453
Monument Mills .....	365	Swift Wool Co.....	59
Murphy, Dan'l I.....	402	Sykes & Street .....	54
Murray, Chas. O.....	26	Taunton-New Bedford Copper Co....	32
New York Mills.....	356	Taylor, James .....	456
New York & Boston Dyewood Co.....	36	Tebbets, E. L. & Co.....	378
Newman Clock Co.....	351	Thompson, James A.....	117
No. Chelmsford Supply Co.....	23	Tucker Stop Motion Co.....	26
Norwood Engineering Co.....	28	Union Special Sewing Machine Co.,	451
Ohio Falls Dyeing & Finishing Co....	101	Universal Winding Co.....	493
O'Neill, Patrick & Co.....	202	Utica Steam and Mohawk Valley Cotton Mills .....	356
Orswell Mills .....	360	Vermont Spool & Bobbin Co.....	160
Pairpoint Co., The.....	21	Vila, H. S.....	35
Parks & Woolson Machine Co.....	11, 15	Von Buchwald, V. J.....	453
Pawtucket Dyeing & Bleaching Co....	391	Walcott & Campbell Spinning Co....	356
Paxton & O'Neill.....	207	Washburn, A. H.....	25
Payne, G. W. & Co.....	455	Watson, L. S. Mfg. Co.....	84
Pepper Mfg. Co.....	457	Whaley, W. B., Smith & Co.....	61
Philadelphia Drying Machinery Co....	18	Whitin Machine Works.....	21
Philadelphia Textile Machinery Co....	17	Whitinsville Spinning Ring Co.....	20
Philadelphia Textile Specialty Ma- chine Co.....	158	Whiton, D. E. Machine Co.....	23
Pitts, James & Son.....	400	Whittier Mills .....	87
Pocasset Worsted Co.....	374	Willett, G. F. & Co.....	407
Price, W. T.....	431	Windle, A. D. & W. W.....	399
Randall, J. & Bros.....	372	Wolf, W. & Sons.....	402
Reis & Co.....	402	Wolfenden, R. & Sons.....	389
Replogle Governor Works, The.....	28	Wood, The Peter Dyeing Co.....	135
Rhode Island Brush Works.....	24	Woodstock Hardwood & Spool Mfg. Co. ....	27
Rice, Henry F.....	26	Yenlo Co., The.....	27
Riggs & Bros.....	351	Young, Wm. M.....	378
Riley, C. E. & Co.....	8		

## **RICHARD A. BLYTHE,** **Commission Merchant,**

Cotton Yarn of Every Description.

114 Chestnut Street,

- - PHILADELPHIA.

---

# Friedberger Mfg. Co.

## EDGINGS AND BRAIDS.

The recognized standard finish used by all the leading manufacturers of Jersey Ribbed Underwear.

### SUPERIOR TO ALL OTHER MAKES

---

Weekly Production Increased to 7,500,000 Yards

---

*Largest Plant*

*Complete Organization*

*Exceptional Facilities*

**RESULTS:** . . . . . **Quick Deliveries**  
**Perfect Goods**

---

**NEW, ORIGINAL AND CORRECT  
PATTERNS EVERY SEASON**

---

No order too large or too small for us to handle.

*Germantown, = = Philadelphia*

Correspondence Solicited



# A DIRECTORY

—OF THE—

# Textile Establishments

—IN THE—

# United States and Canada

Arranged by location, alphabetically, under States, Cities and Towns,  
with maps showing the location of the Textile  
Mill Cities, and Towns.

---

## NEW FEATURES.

---

Each year some new feature has been added to this directory. This edition contains several valuable features.

**The Directory of Textile Establishments in the Dominion of Canada.**

**Textile Maps of the Provinces of Ontario and Quebec.** As we were the originators of the textile map idea, so we publish the first textile map of Canada.

---

## REWARD!

To the person who shall *first* inform us of any cotton, woolen, knitting, silk, flax or jute mill, print works, dyeing (except job dyeing), bleaching or finishing establishment in the United States or Canada\* which was in operation in April, 1902, and which is erroneously omitted from this Directory, we will give \$1.00 in cash, or credit same on subscription account, as he may prefer, subject to the following conditions:—

Full and complete information concerning the mill must be sent. By that we mean the name of the company, where located, names of the officers, including superintendent, class of goods made, capacity in machinery, that is, number of spindles, cards, looms, etc., kind of power, whether a dyehouse or not, name of buyer and selling agents.

We shall also be pleased to learn of any mills which are included in this Directory which should *not* be there owing to failure, going out of business, fire or otherwise. We reserve the right to set our own basis of compensation for this class of information.

In recognizing claims for reward, we can only consider them with reference to the circumstances in April, 1902, as it is manifestly impossible to include mills which may have started subsequent to date of publication.

We especially invite the co-operation of travelling salesmen in the correction of any errors that they may discover.

No other Directory publishers have yet dared to offer a reward for the discovery of inaccuracies.

\*The offer of reward does not apply to small custom earling mills with only one or two custom cards for country rolls, or one or two looms.

**GUILD & LORD, PUBLISHERS,**

95 SOUTH ST., BOSTON.

S. A. H. FOND.

71591

## EXPLANATIONS OF MAPS.

The Directory is illustrated by copyrighted maps of the principal manufacturing states east of the Mississippi River, and the Provinces of Quebec and Ontario, showing the location of the textile mill cities and towns. These maps are engraved especially for the **TEXTILE WORLD DIRECTORY**, and are arranged with special reference to the convenience of those desiring to reach the textile establishments. The Southern, Western, and Central States are arranged in groups; most of the New England and Middle States are shown with separate maps for each State. Under each State heading and at top of right hand pages reference is made to the page of map for that State. The city of Philadelphia being the principal textile centre of the county, is shown by a series of six different maps, covering the manufacturing districts of that vicinity.

The State maps are divided into square sections, designated by letters and numbers. In the body of the Directory, after the name of the city or town, the square in which it is located on the map is designated thus, in the case of Passaic, N. J.—“Passaic, D-9;” meaning that Passaic will be found in the horizontal section D and the vertical section 9 of the New Jersey map.

Following the letters indicating the location of the town will be found abbreviations of the railroad connections, which will enable one to refer intelligently to any railway guide for his train connections. If the town is not on the railroad, the nearest railroad station is given and the distance from it.

It should also be carefully noted that each square is a certain number of miles. Under the title of each map will be found the scale of miles to each square in that map. In this way distances can be very closely approximated, and railroad fares estimated on computation of about 2½ cents per mile in the Eastern States, and 3 to 4 cents in Southern and Central States, for local travel.

The classification of the following section of the Directory is first, alphabetically by States; second, alphabetically by towns and cities in each State; third, alphabetically by name of mill, under its proper post office address. In some instances the railroad and freight station is not the same as the post office address, and in these cases the proper railroad station is designated.

Under each city or town are grouped *all* the textile mills in that place, without regard to kind of goods made. The kind of mill, i. e., whether cotton, woolen, etc., is shown by the bold face letter at the right.

## EXPLANATION OF ABBREVIATIONS.

In order that the general character of the mill may be ascertained without closely reading the data concerning it, a system of abbreviations has been employed as follows:—

<b>C</b> means cotton mill.	<b>W</b> means woolen mill.	<b>S</b> means silk mill.
<b>J</b> means jute mill.	<b>K</b> means knitting mill.	<b>D</b> means dyeing establishment.
<b>Bl</b> means bleachery.	<b>F</b> means finishing works.	<b>Pr</b> means print works.
	<b>Fl</b> means flax mill.	

These abbreviations are placed at right of column, so as to avoid confusion.

**POWER.** The kind of power is designated—steam or water.

**DYE.** If the mill has dyeing facilities, the word “dye” is used.

**S. AGTS.** means selling agents. The other abbreviations will be easily understood.

**BUYER.** In most instances the name of the man who does the buying is given for the larger mills. In smaller mills, or those operated by individuals, the principals usually buy.

## LATE ADDITIONS AND CORRECTIONS.

received too late for classification will be found by reference to the Table of Contents.

## ALABAMA.

See map on page 68.

For explanations of abbreviations see page 66.

**Alabama City.** D.S. 2 1/2 miles from Gadsden.

DWIGHT MFG. CO.; Alabama Mills; R. A. (C) Mitchell, agent; C. H. Moody, supt.; Three and Four-yard Sheetings, Osnaburgs and Drills; 60,000 ring spindles; 1600 looms; steam; Minot, Hooper & Co., s. agts.; agent and supt., buyers. See also Chicopee, Mass.

**Alexander City.** F.S. C. of Ga. RR.

ALEXANDER CITY MILLS; \$200,000; D. L. (C) Davis, pres.; B. P. Lewis, sec.; J. C. Maxwell, treas.; Yarns; 10,000 spindles; steam. Hosiery.

RUSSELL MFG. CO., THE; \$50,000; Benj. (K) Russell, pres.; G. C. Russell, treas.; Ladies' Underwear.

**Anniston.** E.S. W. S. of S. R. Co. RR.; L. & N. RR.; S. R. Co. RR.

ADELAIDE MILLS; \$50,000; T. L. Robin-son, pres.; W. A. Robinson, treas.; 2500 spindles; steam; Buckingham, Paulson & Co., N. Y., Phila and Chicago, s. agts.

AMERICAN NET & TWINE CO.; Gold Medal (C) Twine Mills, W. S. Shepard, pres.; \$350,000; I. W. Adams, treas.; H. F. Williamson, agt., supt. and buyer; Nets, Seines, Lines and Twines; 5000 ring spindles; steam; sell direct. Main office, 93 Commercial St., Boston, Mass.

ANNISTON CARPET CO.; \$50,000; James (W) Backler, gen. mgr.; All Wool and Ingrain Carpets; dye; sell direct (capacity 1500 yds. a day).

ANNISTON CORDAGE CO.; \$50,000; Wm. H. (C) Zinn, pres.; F. W. Jones, treas.; S. C. White, buyer; Sash Cord, Clothes Clothes Lines, Back Bands, Webbing, etc.; 1500 ring spindles; 50 braiding machines; steam; J. J. Collins & Co., Chicago, R. F. Haight, San Francisco, and B. C. Burkinshaw, N. Y., s. agts.

ANNISTON KNITTING MILLS; \$25,000; (K) Alfred L. Tyler, Jr., pres. and treas.; Wilson Weekly, supt.; Children's and Misses' Ribbed Hosiery; 25 knitting machines.

ANNISTON MFG. CO.; \$250,000; A. L. Tyler, (C) pres.; J. B. Goodwin, treas., agent and buyer; Thos. Hampson, supt.; Sheeting, Shirting and Drills; 11,200 ring spindles; 320 looms; steam; sell direct.

ANNISTON YARN MILLS; \$100,000; W. (C) A. Scarborough, pres.; J. T. Gardner, treas.; C. S. Goodwin, supt.; Hosiery Yarns; 5000 ring spindles; steam; Wm. D'Elver & Co., s. agts.; J. T. Gardner, buyer.

WOODSTOCK COTTON MILLS, THE; \$100,000 (C) J. H. Noble, pres.; James Keith, Jr., sec and treas.; J. H. Hines, supt.; 2, 3 and 4 ply Yarn, Skeins and Cones; 10,000 ring spindles; steam; Catlin & Co., s. agts.

**Athens.** C.G. L. & N. RR.

ATHENS COTTON MILL CO.; \$50,000; L. C. (C) Hightower, pres.; C. E. Frost, sec. and treas.; T. M. Hobbs, gen. mgr.; Yarns, single and twisted, averages 20s; 2500 spindles; steam.

LIMESTONE HOSEIERY CO.; \$15,000; (K) J. W. Frost, pres.; Robt. Hendricks, treas.; Children's and Misses Hosiery, 101 needle; 45 knitting machines; steam; dye.

**Birmingham.** E.T. A. So. RR.; C. of G. RR.; B. & T. R. RR.; K. M. & B. RR.; M. & C. RR.; Southern RR. and others.

AVONDALE MILLS CO.; \$500,000; B. E. (C) Comer, pres., treas., and buyer; J. W. Pierson, supt.; Print. Cloth; 38,800 spindles; 1152 looms; steam; sell direct; Chas. Abbott, sec. and buyer.

BIRMINGHAM COTTON MFG. CO.; \$75,000; (C) J. B. Cotton (Chester, Pa.), pres.; J. H. Gary, sec., treas. and mgr.; Warps, 12s to 30s; 4200 ring spindles; Steam. *Idle. Re ported for sale.*

BIRMINGHAM HOSEIERY MILLS; \$25,000; (K) J. A. Yates, pres. and treas.; C. O. Bean, supt.; Misses' Ribbed and Men's Hosiery; 50 knitting machines; dye; sell direct. Formerly Birmingham Knitting Mills.

WILLIAM KNITTING CO.; \$25,000; W. E. (K S) Williams, pres. and buyer; Chas. A. Williams, treas.; Men's Half Hose, in Black and Colors; electricity; dye; sell direct. Expect to begin Sept., 1902.

**Bluff Spring.** F.S. R. R. Station, Goodwater; C. of G. R. R.

STREET, Mrs. M. J.; Wool rolls; 1 set; (W) water. Freight address, Talladega.)

**Columbia.** H.9. C. of G. RR.

COLUMBIA COTTON MILLS; \$50,000; John T. (C) Davis, pres.; H. M. Beach, treas.; Chas. H. Davis, agt.; Carpet Warps from 7 to 9; 3, 4 and 5 ply; 2500 ring spindles; steam; sell direct and James Freeman Brown Co., s. agts.

**Cardova.** E.6. S. RR.; K. C. M. & B. RR

INDIAN HEAD MILLS OF ALABAMA; \$600,000; (C) 000; Arthur Amory, pres.; Harcourt Amory, treas.; J. O. Hamnum, agt.; Sheelings, Drills and Flannels; 27,472 ring spindles; 840 looms; steam; Amory, Browne & Co., N. Y. and Boston, s. agts.

**Demopolis.** F.5. So. Ry.

BESSIE MINGE MFG. CO.; \$100,000; J. H. (C) Minge, pres.; J. C. Minge, treas. and buyer; Yarn, from No. 1 to 8; 3,000 spindles; steam; Catlin & Co., s. agts. (Start July 1, 1902.)

**Dothan.** H.S. Cent. of Ga.

DOTHAN COTTON MILL; S. B. Bennett (C) and others interest in; 10,000 spindles; 300 looms. *Proposed.*

**Elba.** H.7. Plant system.

ELBA COTTON MILL; \$200,000; J. C. (C) Henderson (Troy), pres. *Proposed.*

**Enterprise.** H.S. Plant system.

ENTERPRISE COTTON MILLS; \$125,000; (C) Duck, Osnaburgs, Twine, etc.

**Enfauia.** G.9. C. of G. RR.

CHEWALLA COTTON MILLS; \$50,000; B. B. (C) McKenzie, pres.; D. B. McKenzie, treas.; Jacob Shiffrin, supt.; Brown Sheeting; 6,000 ring spindles; 150 looms; steam; sell direct and Catlin & Co., N. Y., s. agts.

ECLAULA COTTON MILLS; \$150,000; Jno. (C) W. Tullis, pres.; Noah W. Roberts, treas.; P. L. West, supt. and buyer; Brown Sheeting, Drills and Shirting; 26,000 ring spindles; 750 looms; steam; Robinson Hughes Co., Louisville, Ky., s. agts.

**Florence.** C.G. L. & N. RR.; W. S. of S. RR.

ASHERAFT COTTON MILLS; \$150,000; Cyrus (C) W. Asheraft, pres.; E. Asheraft, treas.; 4 yd. Sheetings; 6,240 ring spindles; 200 looms; steam; J. Spencer Turner Co., N. Y., s. agts.; C. W. and E. Asheraft, buyers.

CHERRY COTTON MILLS; \$200,000; N. E. (C) Cherty, pres.; N. C. Elting, treas.; P. R. Jones, supt.; Cotton Yarns and Chain Warps, single and ply; 6 to 40; 11,600 spindles; steam; dye; sell direct and Schell, Taylor & Longstreth, Phila., and Waters & Garland, Louis-ville, s. agts.; N. E. Cherty and P. R. Jones, buyers.

**Gaylesville.** D.S. RR. Station Lawrence;

So. Ry. GAYLESVILLE COTTON MILL CO.; A. D. (C) Hudson interested; Yarn and Sheeting. *Proposed.*

Map of  
**GEORGIA, ALABAMA,**  
**MISSISSIPPI AND**  
**TENNESSEE**

Showing the Textile Mill Towns,  
 Specially engraved for the Textile World.  
 Scale 50 Miles to each Square.  
 Copyright, 1888, by *Gait & Lord, Boston.*

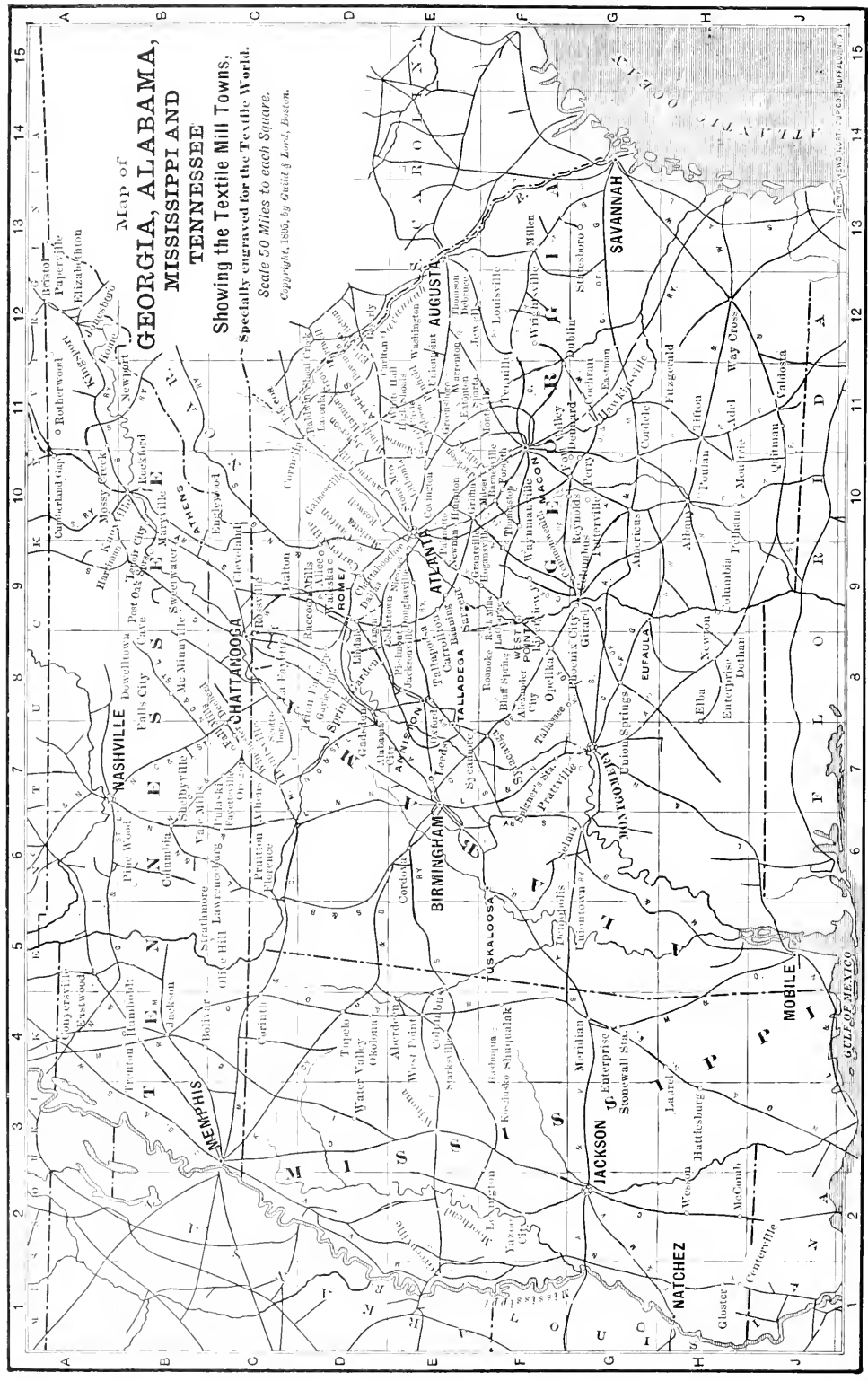

**Girard.** G-9. See *Columbus, Ga.*

**GIRARD COTTON MILLS.** (Owned and operated by Eagle and Phenix Mills, Columbus, Ga., which see.)

**Huntsville.** C-7. W. S. of S. RR.; N. C. & S. L. RR.

**DALLAS MFG. CO.;** \$1,000,000; S. M. Milliken, pres.; T. B. Dallas (Nashville, Tenn.), treas. and gen'l. mgr.; J. L. Davidson, supt.; Treasurer, buyer; Brown and Bleached Sheetings, 36 to 108 in. wide; 51,000 spindles; 1600 broad looms; steam; Deering, Milliken & Co., N. Y., s. agts.

**EASTERN MFG. CO.;** (22 Thomas St., New York City.) \$100,000; Arthur H. Lowe, pres.; Chas. L. Poor, treas.; Fine Ginghams; 200 looms; electricity; dye; J. Harper Poor & Co., s. agts.

**HUNTSVILLE COTTON MILLS;** \$88,500; (C) Sam'l H. Moore, pres.; Luke Matthews, treas.; W. H. Mumroe, supt.; Yarns, 10s to 20s, single and double; 10,000 spindles; steam; Buckingham, Paulson & Co., Wm. D'Olier Co., R. A. Blythe and C. J. Webb & Co., s. agts.

**LOWE MFG. CO.;** \$100,000; J. Harper Poor (New York), pres.; W. L. Wellman (Huntsville), vice-pres.; Arthur H. Lowe (Fitchburg), treas.; Arthur L. Ware, agt.; J. M. Torrence supt.; Fine Cotton Yarns; 12,000 ring spindles; steam.

**MADISON COUNTY SPINNING CO.;** \$100,000; (C) M. Humes, pres.; T. B. Dallas, treas. and gen'l. mgr.; Hosiery Yarns; 5000 mule spindles; steam.

**MERRIMACK MFG. CO.** (of Lowell, Mass. (C) which see); Chas. L. Lovering, treas.; G. T. Marsh, agt.; Print Cloths; 25,000 ring spindles; 848 looms; steam; J. W. Pead, Lowell, buyer.

**ROWE KNITTING CO., W. H.;** \$300,000; (K) W. H. Rowe, Jr., pres.; Frances J. Wood Rowe, treas.; Elmer E. Hartzell, sec.; Chas. E. Shaver agt. supt. and buyer; Cotton Knit Underwear; 5000 spindles; 22 knitting machines; steam; dye; W. H. Rowe, & Son, N. Y., s. agts. and sell direct.

**WEST HUNTSVILLE COTTON MILLS CO.;** (C) \$50,000; T. W. Pratt, pres. and agt.; R. A. Pratt, treas.; Cotton Yarns from No. 2s to 14s, single or twisted in Skeins, Balls, Cones or Tubes; 6000 ring spindles; steam; sell direct and C. J. Webb & Co., Phila., s. agts; T. W. Pratt, buyer.

**Jacksonville.** E-S. E. & W. RR. and S. Ry.

**IDE COTTON MILLS.** (Project suspended.)

**Leeds.** E-7. So. Ry.; C. of Ga. RR.

**THOMPSON, T. C.;** (Birmingham, Ala.) (C) cotton mill. *Proposed.*

**Mobile.** J-5. W. S. of S. RR.; L. & N. RR.; M. & O. RR.

**BARKER COTTON MILL CO.;** \$400,000; Geo. (C) G. Barker, pres.; Francis H. Hills, vice-pres. and treas.; Z. M. P. Inge, sec.; F. S. Mosher, gen'l. mgr.; 3-yd. 36" sheetings and 30" Drills; 20,000 spindles; 600 looms; steam.

**CHEROKEE MILL;** 1200 spindles. *Not (C) running.*

**MOBILE COTTON MILLS;** \$200,000; M. W. (C) Dunlap, pres. and treas.; Geo. H. Greason, supt.; Fine Quality Carded Peeler Knitting Yarns on Cones; 10,000 ring spindles; steam; sell direct; M. W. Dunlap, buyer.

**Montgomery.** G-7. S. A. L. RR.; W. Ry. of A.; C. of G. RR.; A. M. RR.; L. & N. RR.; M. & O. RR.

**ALABAMA CORDAGE CO.;** \$50,000 (paid (C) in); T. S. Young, pres.; Frank McDonald, treas.; W. T. Clayton, supt.; 3 and 4 ply Twine of No. 4 Yarn on Balls, Tubes and Cones; 1100 spindles; steam; dye; H. C. Kelly & Co., N. Y., s. agts.

**MONTGOMERY COTTON MILLS;** \$100,000; (C) A. M. Baldwin, pres.; W. B. Tanner, treas.; Jno. R. Montgomery, supt.; S. F. Ducks, 6 doz. to 12 doz.; 6,600 ring spindles; 166 looms; steam; sell direct and R. McK. Jones & Co., T. A. Shaw & Co., and Robinson-Jughes Co., s. agts.; J. R. Montgomery, buyer.

**PEOPLE'S COTTON FACTORY** (authorized); (C) \$200,000; Jas. Norwood, pres.; T. L. Jones, treas.; John Gegenheimer, supt.; Sheetings and shirtings; 10,000 ring spindles; 320 looms; steam; Putnam, Hooker & Co., s. agts.; John Gegenheimer, buyer.

**TALLASSEE FALLS MFG. CO.;** (Mt. Vernon (C) Woodberry Cotton Duck Co, Baltimore.) (See Tallassee.)

**Newton.** H-S. A. M. RR.

**KILLEBREW, T. J.;** E. N. Alsobrook, (C&W) supt.; T. J. Killebrew, buyer; Woolen Goods and Cotton Yarns and Pants; 128 ring spindles; 18 looms; 10 sewing machines; 1 set; water and steam; dye; sell direct.

**Opelika.** F-S. C. of Ga. RR.; L. RR.; O. & A. RR.

**OPELIKA COTTON MILLS;** \$100,000; C. C. (C) Tarbert, pres.; M. M. McColl, sec. and treas.; T. H. Fairchild, supt.; Warps and Yarns, 14s and 40s; 6,240 ring spindles; steam; M. M. McColl, buyer. (To add 1,250 spindles.)

**Oxford.** E-S. S. RR.

**BLUE SPRING MILLS;** \$50,000; O. W. Cooper, (C) pres.; D. C. Cooper, treas.; O. W. Cooper, buyer; Converters' Goods; 2436 spindles; 80 looms; steam; Wm. D'Olier & Co., Phila., and Catlin & Co., N. Y., Boston, Phila., s. agts.

**Phoenix City.** G-9. (RR. station, Columbus, Ga.) C. of G. RR.

**CHATTANOOCHEE KNITTING CO.** See **K** Columbus, Ga.

**Piedmont.** E-S. E. & W. RR.; Southern RR.

**COOSA MFG. CO.;** \$175,000; A. G. Thatcher, (C) pres.; J. W. Hawke, treas.; John H. Barlow, supt. and buyer; 20-2, 21-2, 20-2 Cotton Yarn; 15,408 ring spindles; steam; sell direct and through Phila. commission merchants.

**Prattville.** G-7. Via Montgomery.

**PRATTVILLE COTTON MILLS & BANKING CO.;** \$125,000; Daniel Pratt, pres.; M. A. Graham, treas.; John Burns, supt.; Osaburgs, Drilling and Fine Sheetings; 10,000 spindles; 290 looms; water and steam; sell direct, and M. R. Dickson, N. Y., s. agts.

**Riverview.** F-S. C. V. RR.

**RIVERDALE COTTON MILLS;** \$100,000; (C) James Pierce, pres.; H. S. Sears, treas.; Wm. Brown, supt.; Duck; 12,000 ring spindles; 338 looms; water; Wellington, Sears & Co., Boston, s. agts.; L. Lanier, vice-pres., buyer.

**Roanoke.** F-S. C. of Ga. RR.

**HANDLEY, W. A., MFG. CO.;** \$100,000; (C) W. A. Handley, pres.; Z. J. Wright, treas.; Wm. N. Randle, agt. and supt.; Cotton Yarns Weaving 20s to 30s, single to 4 ply; Warps or Skeins, Highest Grade; 6,000 ring spindles; steam; sell direct and through agts.

**Rock Mills.** (Randolph County) F-S. (RR. station, Roanoke.) C. of G. RR.

**WEHADKEE COTTON MILLS;** \$24,000; L. S. (C) Turner, pres.; F. P. Randle, treas. and agt.; F. W. Hill, supt.; F. P. Randle, buyer; single and Plied Yarns, 4s to 12s; 3500 spindles; steam and water; sell direct.

**Selma.** G-6. Mo. P. RR.

CAWTHON COTTON MILL CO. (formerly (C) Matthews Cotton Mills Co.); \$125,000; O. F. Cawthon, pres; O. M. Cawthon, treas; Robt. Coleman, sec, agt. and buyer; Sheetings, Shirts, Drills, Ducks, etc.; 13,000 spindles; 410 looms; steam; sell direct; T. L. Wainwright, Stonewall, Miss, s. agt.

ESTELLE COTTON MILLS CO.; \$150,000; (C) (formerly Selma Cotton Mill Co.); O. F. Cawthon, pres; O. M. Cawthon, treas; Robt. Coleman, sec. and supt.; Sheetings, Shirts, Drills, Ducks and Osnaburgs; 10,000 ring spindles; 320 looms; steam; sell direct.

**Spiguer Station.** F-7.

CLARK & Co. (Augusta, Ga.); (leased (C) State Cotton Mill); Duck, Drills and Sheetings; 5000 spindles; 100 looms; steam; dye.

**Spring Garden.** D-S. W. S. of S. RR.

HURRICANE CREEK MFG. CO.; \$50,000; J. (C) M. Martin, pres.; W. H. Burnett, treas., agt., supt. and buyer; Single Cotton Yarn, 6/1 to 12/1, and Cotton Rope, 3/16 to 8/16; 1000 spindles; water; sell dir ct and B. M. & J. E. Stewart, s agts.

**Stevenson.** C-8. (Not shown on map.) N. C. & St. L. RR.; So. Ry.

BROADS COTTON MILLS; H. C. Ray, (C) gen'l mgr.

**Sycamore.** E-7. L. & N. RR.

SYCAMORE MILLS; \$300,000; D. L. Lewis, (C) pres.; J. A. Lewis, sec.; M. R. Chrystal, supt.; Hosiery Yarns, 10s to 26s; 15,000 ring spindles; steam; sell direct.

**Sylacauga.** F-7. C. of Ga. RR.; L. & N. RR.

CENTRAL MILLS (formerly McDonald (C) Cotton Mills); \$150,000; D. L. Lewis, pres.; M. B. Lewis, sec., treas. and gen'l mgr.; Hosiery Yarns, 18s to 30s on cones; 10,080 spindles; steam; sell direct and through agents.

MATHEWS, T. J.; Marble City Hosiery (K) Mill; A. H. Mann, supt; Medium Half Hose; (84 needle) 77 machines; Hunter Mfg. & Com. Co, Greensboro, N. C., s. agts. (Buy mixed and white yarns, 4s to 11's.)

**Talladega.** E-7. B. & H. RR.; W. S. of S. RR.; L. & N. RR.

CHINABEE COTTON MILLS; \$75,000; T. S. (C) Plowman, pres.; F. L. Martin, supt.; Hosiery Yarns; 3500 spindles; steam; Catlin & Co. s. agts.; T. S. Plowman, buyer.

HIGHLAND CITY MILLS; \$50,000; J. H. (C) Hicks, pres; W. H. Boynton, treas; Hosiery Yarns; 5376 spindles; steam; Catlin & Co., s. agts.

TALLADEGA COTTON FACTORY; \$50,000; J. (C) B. McMillan, pres.; G. A. Joiner, treas; John J. Doyle, supt.; G. A. Joiner, buyer;

Cotton Hosiery Yarn, 6s to 24s; 5000 ring spindles; steam; Wm. D'Ollier & Co., Phila., s. agts.

TALLADEGA HOSEIERY MILLS; \$16,000; H. (K) L. McElderry, pres.; W. T. Billue, treas.; E. L. Holland, supt; Hosiery; 136 and 176 needle; 30 knitting machines; 5 ribbers; 7 looms; 2 sewing machines; steam; dye; sell direct; W. T. Billue, buyer. (Buy white hosiery yarn, 6-20.)

**Tallassee.** G-S. Tal. & Mont. RR.

TALLASSEE HATS MFG. CO.; Shirts, (C) Sheetings, Osnaburgs, Duck, Rope, Twine; 75,000 ring spindles; 650 looms; steam; dye; J. Spencer Turner Co., N. Y., s. agts.

**Tuscaloosa.** F-6. A. G. S. RR.

ROPE & YARN MILLS; \$30,000; Geo. A. (C) Searey, pres. and treas.; J. P. Thilroy, supt.; Yarns, Twine and Small Cordage; 1600 spindles; steam and water; sell direct; G. A. Searey, buyer.

ROSENAU HOSEIERY MILLS; \$50,000; D. L. (K) Rosenau, pres.; M. D. Rosenau, treas.; Ladies' Cotton Hosiery; 50 knitting machines; steam; dye. (In plant formerly operated as wadding mill.)

SNOW, J., HARDWARE CO.; \$20,000; C. N. (C) Maxwell, pres.; J. W. Sanders, treas. and buyer; L. D. Sanders, supt; Drills, Sheetings, Skein and Yarn Warps; 4360 ring spindles; 108 looms; steam; Robinson Hughes Co, Louisville, s. agts.; J. W. Sanders, buyer.

TUSCALOOSA MILLS; \$60,000; J. Pollock, (C) pres.; D. L. Rosenau, treas. and sec.; Checks, Plaids, Stripes, Specialties, Sheet- ing, Twines, Wick, Mop, Batts; 15,000 spindles; 360 looms; steam; dye; sell direct. (RR station, Cottondale.)

**Union Springs.** G-S. C. of G. RR.

UNION SPRINGS COTTON MILLS (author- (C) ized; \$80,000;) (paid up \$46,000;) C. H. Franklin, pres; J. H. Rainer, Jr., treas. and sec; D. J. Howard, supt; Cotton Hosiery Yarns from 4s to 12s, in Cops, Cones and Skeins; also Manufacture Shuttle Cops; 2000 ring and 3000 mule spindles; steam; Edw. S. Hyde and Chas. J. Webb & Co., Phila., and Waters Garland Co., Louisville, s. agts; pres. and treas., buyers.

**Uniontown.** G-6. S. RR.

ELLAWHITE COTTON MILLS; J. H. (C) White, pres; V. Taylor, sec. and treas; Yarns; 3,500 spindles; steam. (Reported to double capacity.)

UNIONTOWN WAREHOUSE CO (successors (C) to Uniontown Rope Mill); \$20,000; W. H. Taylor, pres; Walter J. White sec. and treas; Jno. A. Hardie, mgr; Cotton Rope; 650 spindles; steam; sell direct.

**ARKANSAS.**

No map.

For explanation of abbreviations see page 66.

**Arkadelphia.** Mo. P. RR.

OUACHITA COTTON MILLS; S. R. McNeill, (C) prop.; 8 oz. Duck and Osnaburg; 3,000 ring spindles; 72 looms; steam; sell direct. *Not in operation.*

**Camden.** St. L. RR; Mo. P. RR.

CAMDEN WOOLEN MILL; D. W. Chaud. (W) lder, trustee; 1 set; 6 looms; steam. *Not running; for several years.*

**Centre Point.** (RR. station, Nashville.) A & L. RR.

CENTRE POINT WOOLEN MILLS; J. A. (W) Hughes, prop.; F. W. Veitch, supt; Jeans, Flannels, Kerseys, Cassimeres, Blankets and Yarn; 1 set; 2 custom cards, 12 looms; steam; dye; sell direct; F. W. Veitch, buyer.

**Dardanelle.** D. & R. RR.

DARDANELLE COTTON MILLS; \$50,000; J. (C) A. Croom, pres; J. D. Kennedy, sec, treas. and gen'l mgr; Wrapping Twines and Coarse Hosiery Yarns; 3000 ring spindles; steam; sell direct. (Buy twist and ply

yarns Nos. 2 to 12s and single and two ply; 4s to 8s.)

**Fordyce.** St. L. RR.

ACRUMAN, E. A.; \$25,000; Knitting Yarn, (W) Jeans, Tweeds; 1 set; 4 looms; steam; sell direct.

**Hamburg.** RR. Station Portland, M. P. H. & W. RR.; St. L., I. M. & S. RR.

HAMBURG COTTON FACTORY ASSO.; \$100, (C) 000; W. A. Gulleck, sec.; Osnaburgs, Brown Drillings, Plaids, Cotton Rope, etc.; steam; dye. *Proposed.* Nothing done recently.

**Helena.** A. M. RR.; St. L., I. M. & S. RR.

PREMIER COTTON MILLS; \$100,000; E. C. (C) Hornor, pres.; R. C. Burke, treas.; Benj. Nuttall, supt. and mgr; Yarns, 40/2 to 60/2; 3250 ring spindles; steam; Wm. D'Oliver & Co., Phila., s. agts; R. C. Burke, buyer. Mills at Barton.

**Little Rock.** L. R. & M. RR.; M. & L. R. RR.; St. L., I. M. & S. RR.

THOMAS COTTON MILLS; \$75,000; Dr. A. (C) D. Thomas, pres.; H. M. Bennett vice-pres.; W. T. Black, sec. and treas.; T. G. Williamson, supt.; Commercial Wrapping Twine, Clothes Lines, Carpet Warps, etc.; 3360 ring spindles; steam; Schermerhorn Bros. & Co., Chicago, s. agts; T. G. Williamson, buyer.

**Mammoth Spring.** K. C., F. S. & M. RR.

MAMMOTH SPRING COTTON MILLS; \$150, (C) 000; C. G. Eno, pres.; L. N. Leslie, treas.; J. D. Kennedy, supt.; Yarns, Duck, Drillings and Sheetings; 8000 ring spindles; 200 looms; water; sell direct. *Machinery or mill plant for sale.*

**Monticello.** St. L., I. M. & S. RR.

ANDERSON COTTON MILL; \$100,000; T. H. (C) Mathews, pres.; W. N. Brown, agt. and supt.; Osnaburgs and Sheetings; 5,000 ring spindles; 150 looms; steam; Catlin & Co., Boston, s. agts.

**Morrilton.** St. L., I. M. & S. RR.

SCANLON, JOHN; Yarns; Jeans, Linseys (W) and Blankets; 1 set; 40 ring and 240 Jack spindles; 6 looms; steam.

**Nashville.** A. & L. RR.

ARKANSAS WOOLEN MILLS, (inc); 1 (W) Lowenberg, pres.; J. J. Gelbart, sec. and treas.; Jeans, Linseys, Cassimeres, Blankets and Yarns; 1 set; 1 broad and 10 narrow looms; steam; dye; sell direct.

**Quinman.** St. L., I. M. & S. R. R.

MIDDLETON BROS.; Wool Rolls and Bat. (W) ting; 2 cards; steam; (R. R. station at Searcy.)

**Springdale.** St. L. & S. F. RR.

HAXTON, W. B. & Co.; \$150,000, (W) supt. and buyer; Jeans, Flannels, Cassimere Yarns and Blankets (custom); 2 sets; 11 looms; steam; dye; sell direct.

## CALIFORNIA.

No map.

For explanation of abbreviations see page 66.

**Agnews.**

LICK WOOLEN MILLS. See San Francisco, (W)

**Eureka.** E. R. & E. RR.

HUMBOLDT BAY WOOLEN MILLS Co.; (W) \$100,000; J. W. Henderson, pres.; Humboldt County Bank, treas.; A. W. R. Berr, supt. and buyer; Flannels, Blankets, Cassimeres and Worsteds; 3 sets; 16 looms; electricity; dye; sell direct. (Buy 2/30 to 2/40 worsted yarns, and 10s to 18s single and 30s to 40s 2 ply warps.)

**Los Angeles.** A. T. & S. F. RR.; L. A. T. RR.; Redondo Beach RR.; S. P. RR.

LOS ANGELES WOOLEN MILLS, Blankets (W) and Flannels; 1 set; 7 looms; water; dye; sell direct. *Mills closed indefinitely.*

SWEENEY, W. W. Co.; 213 W. Fourth St.; (K) Elastic Hosiery and Supporters.

WHIPPLE, J. L.; Los Angeles Shoddy (W) Works, 834 Paladina Ave.; Shoddy; 2 pickers; steam.

**Marysville.** S. P. RR.

MARYSVILLE WOOLEN MILLS; \$70,000 (W) John Martin, pres.; N. D. Rideout, treas.; Melfous, Kerseys, Police Cloths, staple Suitings and Overcoatings; also Wool Blankets and Flannels; 5 sets; 40 looms; electric; dye; T. M. Grant, s. agt.

**Napa.** S. P. RR.

NAPA WOOLEN MILL; \$100,000; S. E. (W) Holden, pres. and buyer; L. C. Norton, treas.; Wm. N. R. McDougall, agt. and supt.; Mackinaw Flannels and Blankets; 5 sets; 22 looms; steam; dye; Murphy, Gant & Co., San Francisco, and T. A. Shaw & Co., Chicago, s. agts.

**Oakland.** C. & N. RR.; S. P. RR.

CALIFORNIA COTTON MILLS Co.; \$1,250, (C&J) 000; Geo. L. Center, pres.; Bank of California, San Francisco, treas.; J. Y. Millar, sec. and agt.; Wm. Rutherford, supt; Cot-

ton and Jute Goods; 10,000 spindles; 200 looms; steam; dye; sell direct; J. Y. Millar, buyer.

CALIFORNIA FLAX MILL; B. Eitinger, (E) pres.; Thread and Twine.

**Petaluma.** S. F. & N. P. RR.

CARLSON CURRIER Co.; \$150,000, J. Parker (S) Currier, pres. and treas.; F. W. Brown, supt. and buyer; Spool, Knitting and Fast Dye Embroidery Silks; 2,000 spindles; steam; dye; sell direct; 6 and 8 Sutter St., San Francisco.

**San Francisco.**

AUERBACH & THOMPSON (Pacific Fringe (S) Factory); Fringes.

BLOCK BROS. KNITTING Co.; 13 Geary (K) St.; Sweaters, Bathing Suits, Theatrical Tights; 6 knitting machines; sell direct.

CALIFORNIA JUTE MILL Co.; 409 California (J) St.; mill at East Oakland; \$240,000; L. P. Dexter, pres.; 2352 spindles; 125 looms; steam. *Closed indefinitely.*

COLLINS, J. W. (See Ashland Woolen Mills and Union Woolen Mills.

COLOMBAT, ALBERT, & Co; Fringes, (S) Braids, Ornaments and Cords; (buy cotton, worsted and mercerized yarn); Henry Colombat, buyer; sell direct.

ETINGER, M.; 723 Market St.; Cords, (S) Tassels and Ladies' Dress Trimmings; 8 looms; 100 braiders; 2 sewing machines; electricity.

GANTNER & MATTERN Co.; Golden Gate (K) Knitting Mills, 20 Post St.; \$100,000; J. O. Gantner, pres.; G. A. Mattern, supt.; Men's and Women's Underwear, Silk, Woolen, Cotton, Lisle and Knitted Linen Mesh, Hosiery, Sweaters, Bathing and Athletic Suits; 90 knitting machines; electricity; sell direct; firm, buyers.

**GOLDEN GATE WOOLEN MFG. CO.**; \$200, (**W**) 000; S. T. Gage, pres.; Wm. MacCann, treas. and agt.; Robt. Broad, supt.; Tweeds, Chevots, Kerseys, Cloth, Blankets and Flannels; 8 sets; 38 looms; steam; dye; sell direct, and Thomas Kelly & Co., N. Y. and Boston.

**LICK WOOLEN MFG. CO.**; 3639-19th St.; (**W**) \$250,000; H. G. C. Atwater, pres.; J. G. Scott, treas.; R. H. Duncan, agt. and supt.; Flannels, Blankets, Cassimeres; 4 sets; 20 looms; steam and water; dye. (Mill at Agnews.)

**MEAGHER, JAS. SONS**; 325 28th St.; Oakum; (**J**) 2 cards; sell direct.

**PEISTER, J. J., KNITTING CO.**; \$100,000; (**K**) (\$82,000 paid up); 56 Geary St.; J. J. Peister, pres. and treas., mgr. and buyer; Knit Underwear, Athletic Goods, etc.; 100 knitting machines; electricity; sell direct.

**PIONEER SILK FACTORY**; Higgenbotham (**S**) & Co.; 31 Jessie St.; Knitting and Embroidery Silks, Tram, Floss, etc.; steam; dye; sell direct.

**TUBBS CORDAGE CO.**; (Inc.) Cordage, (**J**) etc.

**WESTERN WOOL MFG. CO.**; Shoddy; 3 (**W**) pickers.

**Sau Jose. S. P. RR.**

**SAN JOSE WOOLEN MILL CO.**; \$211, (**W & K**) 400; D. B. Moody, pres.; G. K. McDonald, sec.; Jas. A. Peckham, treas.; A. McDonald, supt.; Worsteds, Cassimeres, Blankets, Flannels; 10 knitting machines; 6 sets; 22 looms; steam; dye; Oelbermann, Dommerich & Co, s. agts, A. McDonald, buyer. (Buy worsted yarn.)

**Sau Quentin. N. P. Coast RR.**

**SAN QUENTIN JUTE FACTORY**; (State (**J**) Prison); W. M. Byrnes, supt.; Grain Bags; 3272 spindles; 4 sets; 200 looms; steam; M. G. Aguiere, Warden, buyer.

**Santa Rosa. S. F. & N. P. RR.**

**SANTA ROSA WOOLEN MILLS**; W. B. (**W**) Humbert, prop.; Blankets; 2 sets; 16 looms; steam; dye.

**Stockton. S. P. RR.**

**STOCKTON RUG AND CARPET MANU.** (**W & S**) FACTORY; Sebastian Iselin, propr.; Carpet-Rugs, Rag Carpets and Silk Portieres; 3 looms; hand power; sell direct. (Buy 3 and 4 ply carpet warps, jute.)

**STOCKTON, THE WOOLEN MILLS**; J. H. (**W**) Neustadter, pres; Geo. W. Tatterson, treas. mgr. and buyer; Blankets, Flannels, Chevots and Cassimeres; 9 sets; 50 looms; steam; dye; sell direct, and Neustadter Bros., San Francisco, s. agts. (Buy yarns.)

## COLORADO.

No map.

or explanation and abbreviations see page 66.

### Denver.

**BILGER, G.**; Rag Carpets, etc.; 2 broad (**W**) looms, 1 narrow loom; hand power. (Buy 4 and 5 ply cotton warps.)

**OVERLAND COTTON MILL CO.**; \$250,000; (**C**) J. K. Choate, pres. and mgr.; J. L. Jerome, treas.; R. L. Cunnock, supt.; Shirtings, Fancy Flannels, Sheetings, Ducks and Drills; 19,000 spindles; 481 looms; steam;

dye; sell direct; J. K. Choate, buyer, (RR. station, Overland.)

**Trinidad. A. T. & S. Fe RR.**; C. & S. RR.; D. & G. RR.

**FORBES WOOL CO., THE**; \$25,000; E. J. (**W**) Huling, pres. and mgr.; Custom Wool Scouring; Brown & Adams, Boston, Mass. s. agts.

## CONNECTICUT.

See map on page 74.

For explanation of abbreviations see page 66.

**Addison. C.5.** Electric Cars from Hartford to Glastonbury.

**GLASTONBURY KNITTING CO.**; Hewitt (**K**) Coburn, Jr., pres.; J. W. Hadstead, treas.; Men's Fine Wool and Merino Underwear; 12 sets; 24 knitting machines; water and steam; dye; sell direct. Also Mills at Manchester Green.

**Ansonia. E.3 N. Y., N. H. & H. RR.** Naug. and Berk. Div.

**ANSONIA BRASS & COPPER CO.**; W. E. (**C**) Dodge, pres.; W. H. Matthews, sec.; Cotton and Silk Covered Insulated Wire; sell direct.

**ANSONIA, O. & C. Co.**; \$100,000; F. S. (**C**) M. Blum, pres; Geo. O. Schmeller, treas.; A. T. Terrell, sec., mgr. and buyer; Suspenders, Garters, Webs, Cor-set Laces and Hoop Skirt Materials, etc.; 150 looms; 2500 braiders; water and steam; dye; sell direct. (Buy 2½/2 to 40/2 mercerized yarn and 5s to 60s cotton yarn.)

**Atwoodville. B.8.** Station at Willimantic on N. H. RR, Cent. Vt.

**MACFARLANE, J. S.**; Throwster. (See (**S**) Mansfield Centre.)

**Ballouville. B.9.** In Killingly, on N. Y. & N. H. & H. RR

**BALLOU MILLS** of the Attawaugan Co; (**C**) C. W. Perkins, supt.; Sheetings and Cambries, Twills, Shirtings and Sateens; 9,840 ring and 10,816 mule spindles; 418 looms; steam and water. Also mills at Killingly and Montville.

**Baltic. D.8. N. Y. & N. H. & H. RR.**

**BALTIC COTTON MILLS CO.**; \$600,000; F. (**C**) C. Sayles, pres.; F. C. Sayles, Jr., treas.; Nathan R. Gardiner, agt.; Fine Cottons; 80,000 spindles; 1600 looms; water and electricity.

**SHETUCKET WORSTED MILL**; M. H. Don (**W**) aho; Worsted Suitings and Trouserings; 2 sets; 33 looms; steam and water; dye; J. L. Briggs & Sons, s. agts. (Buy cotton and worsted yarns, all kinds.)

**Bethel. E.1.** (Not shown on map.) N. Y., N. H. & H. RR.

**BETHEL SILK CO.**; \$50,000; John Sprich, (**S**) pres.; Max Doerken, treas. and supt.; Broad Silks; 50 looms; steam.

**Bethlehem. C.2.** Stage at Watertown, on N. Y., N. H. & H. RR, Naug. Div.



- BIRD, THEO.** Going out of woolen (**W**) business.
- Birmingham.** F-3. See Derby, also Shelton.
- Bozrah.** D-7. Stage 2m at Yantic on Cent. Vt. RR, and Stage 6m at Norwich on N. Y., N. H. & H. RR, Nor. and Wor. Divs. and Cent. Vt.
- PALMER BROS. CO., THE;** Geo. S. Palmer, (**C**) supt.; Bed Comfortables; 40 cards; water and steam; sell direct, N. Y. office, 56 Leonard St.; P. O. and freight address, Fitchville.
- Bridgeport.** G-2. Y. Y., N. H. & H. RR, N. Y. Div., Berk. and Naug. Divs.
- BRIDGEPORT COACH LACE CO. (W & S** \$15,000; F. J. Naramore, pres; W. W. Naramore, treas. and supt.; Coach Lace, Tassels and Trimmings; 20 looms; steam; sell direct; F. J. Naramore, buyer.
- BRIDGEPORT ELASTIC WEB CO.** Absorbed by Hub Gore Makers and machinery removed to mill at Brockton, Mass.
- BRIDGEPORT SILK CO.;** M. C. Patterson; (**S** F. M. Patterson, buyer; James G. Simpson, supt.; Dress, Carriage, Umbrella and Novelty Silks, Plain and Figured Handkerchiefs, etc.; 250 looms; steam and electricity; sell direct, New York office, 81 Greene St.
- CAMP-CARL KNITTING CO.** *Out of business.*
- CANFIELD RUBBER CO, THE;** \$250,000; Rat (**K**)cliffe Hieks, pres; C. F. Holecomb, treas. and supt.; Seamless Stockinet; Dress Shields; 44 knitting machines; steam; The Warner Bros. Co; N. Y. s. agts; C. F. Holecomb, buyer. (Buy 32 carded and 40-50 combed yarns.)
- CONNECTICUT WEB CO., THE;** \$50,000; Leo (**C**)pold Rothschild, pres; L. Neuberger, treas. and supt.; Elastic and Non-Elastic Webbing; 57 looms; steam; dye; M. L. Rothschild, 260 West Broadway, Rooms 315 and 316, s. agt.
- CYLINDROGRAPH EMBROIDERY CO.;** cor. (**W**) Railroad and Hancock Aves; Jos. Irish, mgr; Embroidered Flannels and Novelties; 21 embroidery machines; steam; sell direct.
- MILLS W. S.;** Lewis E. Rising, supt; In- (**K**)fants' Fine Underwear; 25 knitting machines; steam; Sam'l Lautenbach, 43 Leonard St., N. Y., s. agt.
- READ CARPET CO.;** \$200,000; M. W. Sey. (**W**)mour, pres; FAW, Read, treas. and buyer; D. F. Read, see; Axminster and Ingrain Carpets and Rugs; 63 looms; steam; dye; The D. M. Read Co, Bridgeport, s. agts; (buy yarns.)
- SALT'S TEXTILE MFG. CO, THE;** \$100. (**S & C**) 000; Fred E. Kip (50 Leonard St., N. Y.), pres; Chas. Fred'k Stead, treas; Silk and Seal Plushes, Velvets and Cotton Velours; steam; dye; sell direct.
- Bristol.** C-4. N. Y., N. H. & H. RR.
- BIRGE, N. L. & SONS' CO.;** \$30,000; John (**K**) Birge, pres; Geo. W. Birge, treas; Cotton Merino and Wool Underwear; 5 sets; 39 knitting machines; steam and water; Isaac P. Graff & Co, N. Y., s. agts.
- BRISTOL MFG. CO.;** \$75,000; F. G. Hay. (**K**)ward, treas; Knit Underwear; 8 sets; 32 knitting machines; steam and water; sell direct. N. Y. salesroom, 43 Leonard St.; Boston, 78 Chauncey St. (Also Plainville, Ct.)
- EDGERTON, M. D.;** Knit Tubular Cover (**K**)ings and Mops; 6 knitting machines; 1 sewing machine; steam and water; sell direct.
- Broad Brook.** A-6. N. Y., N. H. & H. RR.
- BROAD BROOK CO.;** \$400,000; F. C. Cooley, (**W**)pres; Chas. M. Beach (Hartford), treas.
- James Brook, agt; W. M. Lasbury, supt; Woolens and Worsteds; (buy 1/6 to 2/4 yarns); 17 sets; 100 looms; water and steam; dye; Ogden & Brook, 526 Broadway, N. Y., s. agts.
- Buckland.** B-6. In Manchester, on N. Y., N. H. & H. RR.
- HILLIARD, E. E. Co, THE;** (Inc.) \$125,000; (**W**) E. C. Hilliard, pres. and treas; E. H. Cooper, sec. and agt; J. B. Barron, supt; Kerseys, Fancy and Union Cassimeres; 12 sets; 40 narrow, 50 broad looms; steam and water; dye; sell direct; N. E. McCoy, agt., 377 B'dway, N. Y.
- Burlington.** B-4. N. Y., N. H. & H. RR, Northampton Div.
- BROADBENT, J. & SON;** Removed to (**W**) main plant at Unionville, which see.
- Central Village.** C-9. N. Y., N. H. & H. RR, N. and W. Divs.
- PLAINFIELD WOOLEN CO.;** \$100,000; C. (**W**)Bragg, treas.; J. F. Milner, sec.; Fancy Worsteds and Wootens; 5 sets; 40 looms; steam and water; dye; Faulkner, Page & Co., s. agts. (Formerly Kirk Mills.)
- THOMAS SHELTON;** Wicking; 12 sets; 900 (**C**)spindles; water; sell direct. (Reported sold to other parties.)
- Colchester.** D-7. N. Y., N. H. & H. RR.
- TURNER, A. G.** (branch mill.) Throwing (**S**) Silk Thread. (See Williamantic.)
- Colebrook.** A-3. Central N. E. Ry.
- SAWYER, HENRY S** (estate of); G. S. Ives, (**C**)treas; C. D. W. Sawyer, agt; Belting and Hose Duck; 3616 ring spindles; 21 looms; water; N. Y. office, 150 Nassau St. Freight address, Winsted, *Idle.*
- Coventry.** See So. Coventry.
- Danbury.** E-1. N. Y., N. H. & H. RR, Dan Div.
- IRVING, J. G.** Rose Hill Silk Works; (**S**) Silk Ribbons and Hat Bands; 5 looms; steam; sell direct.
- TWEEDY, A. E.;** Silk Hat Bands and (**S**) Braids; 50 looms; steam; sell direct.
- Danielson.** B-9. N. Y., N. H. & H. RR. (See also Killingly.)
- ELMVILLE WOOLEN CO., THE;** (form- (**W**)erly Chase Mill.) \$10,000; S. L. Hecht, pres.; Louis Rittenberg, treas.; Mr. Kimball and John Horan, supts.; Piece Dye Cheviots and Tiborats; 4 sets; 25 broad looms; steam and water; dye; S. L. Hecht & Co., s. agts. (Al-o Saxton's River, Vt.)
- DANIELSONVILLE COTTON MILL;** Coch (**C**)rme Mfg. Co.; J. W. Ball, supt; Sheetings and Shirtings; 21,080 spindles; 451 looms; water and steam. See also Dedham and Malden, Mass.
- QUINEBAUG CO.;** \$500,000; R. C. Taft, (**C**)pres.; J. W. Danielson (Prov.) treas; J. Arthur Atwood, agt; J. H. Smith, supt.; Sheetings and Shirtings; 31,920 ring and 28,024 mule spindles; 1516 looms; water and steam; sell direct; Whitin, Collins & Co., and Deering, Milliken & Co., N. Y., s. agts.
- LINCOLN KNITTING CO.;** Charles P. Backus, (**K**)pres; Win. H. Putnam, treas. and supt.; Misses' Fine Seamless Ribbed Hose, Fine Hat Hose; and Infants' Cashmere Hose; 75 knitting machines; steam; sell direct. (Buy different sizes Carded Peeler, Combed Egyptian and Spun Silk Yarns.)
- Dayville.** See also Killingly and Danielson, B-9.
- SAYLES, LOUIS G.;** Shoddy; steam; sell (**W**)direct.
- Derby.** F-3. N. Y., N. H. & H. R. R.
- ALING, A. H. & C. B.;** Paussett Mills; (**K**) Flat Wool Underwear and Wool and Worsted Half Hose; 14 sets; 6000 spindles; 375 knitting machines; water and steam;

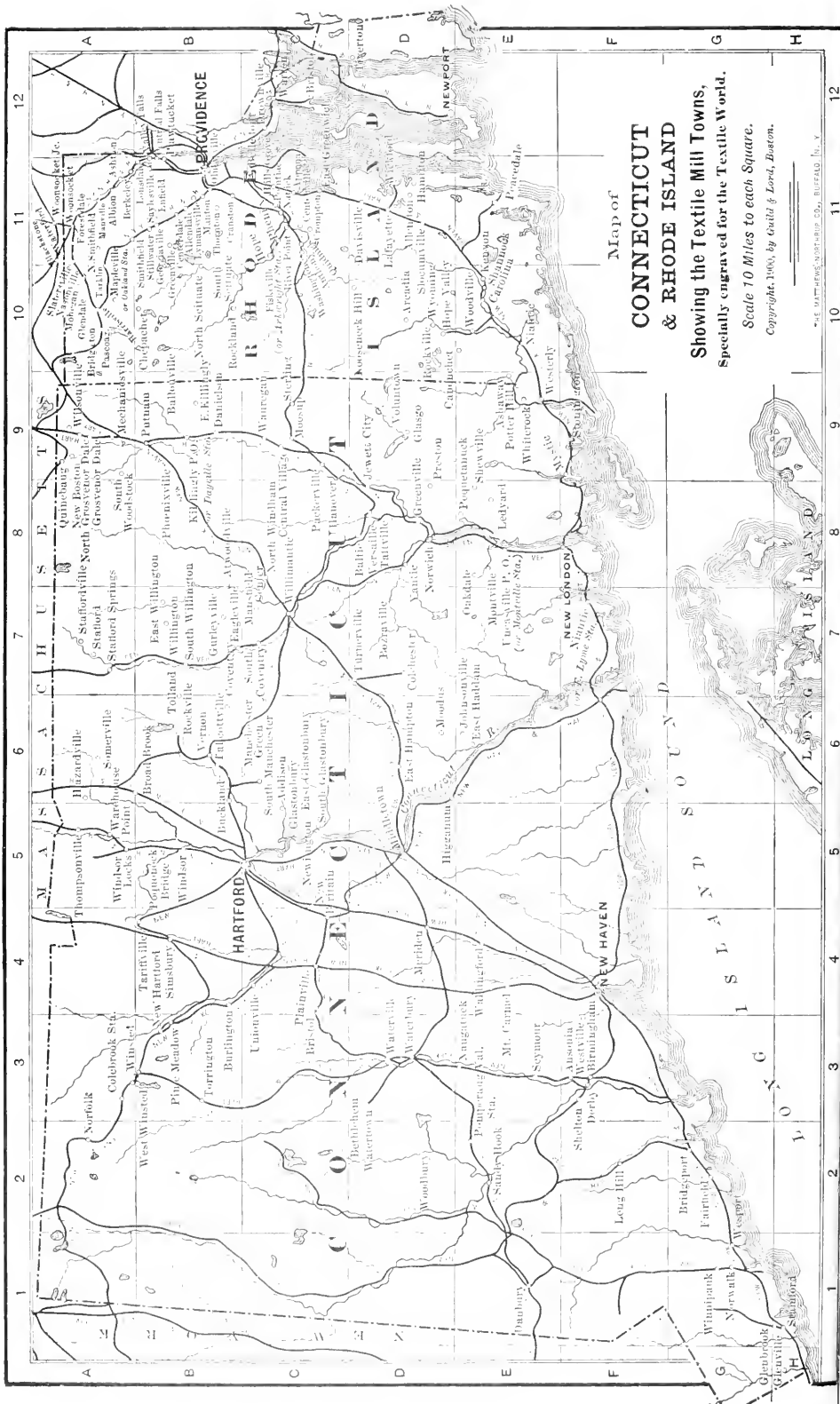

Map of

# CONNECTICUT & RHODE ISLAND

Showing the Textile Mill Towns,  
Specially engraved for the Textile World.

Scale 10 Miles to each Square.  
Copyright, 1900, by Gould & Lord, Boston.

- dye; sell direct. (Buy Cotton Yarn, 10s to 40s, singles (skin) white and mixes, Worsted (French) 1/20s to 1/40s, white and mixes and Worsted Merino, 1/20s to 1/40s, white.)
- Eagleville.** B-7. Cent. Vt. RR.
- EAGLE MILL;** John L. Ross (Prov.), (C) prop; James H. Ross, agt; T. M. Ross, supt; Twills; 5,120 ring and 5,184 mule spindles; 172 looms; steam and water; M. Heineman, and C. H. Pope & Co., N. Y., s. agts; John L. Ross and M. Heineman, buyers.
- East Glastonbury.** C-6. See Glastonbury and So. Glastonbury.
- East Haddam.** E-6. See Moodus.
- East Hampton.** D-6. N. Y., N. H. & H. RR, Air Line Div.
- STARR NET & TWINE CO;** Fish Netting, (C) etc.; 6 machines; water.
- SUMMIT THREAD COMPANY;** \$250,000; (C) D. King, pres.; T. King, treas. (Boston); E. G. Cone, agt., buyer, asst. treas. and supt; All Kinds of Spool Cotton Thread; (buy all kinds yarns); steam and water; dye; sell direct.
- East Killingly.** B-9. Stage at Danielsonville, on N. Y., N. H. & H. RR. See also Killingly.
- WHITESTONE MILL;** 4256 spindles; 150 (C) looms; steam and water. *Sold to H. T. Wescott, Danielson, Conn. Not running.*
- YOUNG, B. C.;** Shoddy and Rag Picking. (W)
- East Lyme.** E-7. N. Y., N. H. & H. RR; New Lon. Div.
- NIANTIC MFG. CO;** Mill No. 1; \$75,000; (W) D. R. Campbell, pres.; Wm. Park, treas. and agt; All Wool Fancy Cassimeres, Suitings; 8 sets; 37 looms; steam and water; dye; Fred'k Almy & Co., N. Y., s. agts.
- TABOR ROCK MILL;** A. R. Darrow, prop; (C) Rope, Candle and Miners' Wicking; Clothes Line, Cotton Mops; 3500 spindles; 3 sewing machines; water; sell direct. (P. O., New London.) Owing to fire reported not in operation.
- East Putnam.** B-9. In Putnam, on N. Y., N. H. & H. RR.
- CHAPMAN MILLS;** J. A. Chapman, supt; (W) Satinets; (buy 18s cotton warp); 2 sets; 24 looms; also custom picking and carding; 5 pickers; 4 cards; water and steam; Fred Wiley, 47 Leonard st., and James Talcott, N. Y., s. agts.; A. E. Chapman, buyer.
- East Willington.** B-7. Station at Tolland, on Cent. Vt. RR.
- WALKER, DENNISON;** Daleville Mills; (W) formerly Jas. Hoyle; Cotton Warp Dress Goods; 2 sets; 15 broad looms; steam and water; dye; sell direct and Fred'k Vietor & Aehelis, s. agts.
- Fairfield.** G-2. N. Y., N. H. & H. RR.
- FAIRFIELD RUBBER CO;** Carriage Cloth (W) Specialties.
- Glasgo.** D-9. Station at Jewett City, on N. Y., N. H. & H. RR.
- GLASGO YARN MILLS CO.;** (Am. Thread (C) Co.); R. C. Kerr, pres.; E. S. Boss, treas.; J. T. Wilbur, mgr.; Fine Combed Cotton Yarns; 18,000 spindles; water and steam; Am. Thread Co., N. Y., s. agts.
- Glastonbury.** C-5. Stage and electrics at Hartford, on N. Y., N. H. & H. RR. See also So. Glastonbury.
- CROSBY MFG. CO.;** \$20,000; David Gor (W) don, pres.; A. O. Crosby, treas. and agt; David Kessler, supt.; Flannels; 11 sets; 48 looms; steam and water; dye; Fred'k Almy & Co., s. agts. (P. O., E. Glastonbury.)
- Glenbrook.** H-1. N. Y., N. H. & H. RR, N. Y. Div. and New Canaan Br.
- KIRKHAM, JOHN R.;** Stamford Knitting (K) Mill; Wooten, Worsted and Cashmere Leggings and Gaiter Drawers; 12 knitting machines; 1 sewing and 1 crochet machine; steam; Mueller, Ambler & C., 369 Broadway, N. Y., and 207 Medina Temple, Chicago; A. Busch & Co, 298 Arch St., Phila., s. agts. Buy 3/20s, 2/22s, 2/19s wooten yarns and 3/21s and 2/21 worsted yarns.
- Glenville.** H. Station at Port Chester, N. Y., on N. Y., N. H. & H. RR, N. Y. Div.
- AMERICAN FELT COMPANY;** (See N. Y. (W) City for felts.); Jas. H. Hmit, supt.; Woolens; 20 sets; 60 looms; steam and water; dye; sell direct.
- REYNOLDS, SOLOMON;** Blown Furs for (W) Hatters; 4 pickers; steam and water; sell direct.
- Grosvenordale.** See No. Grosvenordale.
- Gurleyville.** B-7. Stage at Willimantic, on N. Y., N. H. & H. RR, Cent. Vt. RR.
- HANKS, P. G.;** (P. O. address, Spring (S) Hill); C. J. Fuller, supt.; Machine Twist and Sewing Silks; 1000 spindles; steam and water; Wm. McNulty, 638 Broadway, N. Y., s. agt.
- SMITH, E. L.;** Throwing of Machine (S) Twists, Embroidery, Floss and Sewing Silks; 1000 spindles; steam and water, (Capacity, 400 lbs. silk per week).
- Hanover.** C-8. In Sprague, on N. Y., N. H. & H. RR.
- AIRLIE MILLS;** Angus Park; George (W) Park, supt; All Kinds Fine Men's Wear; 6 sets; 27 looms; steam and water; dye; Fred'k Almy & Co, s. agts. (Formerly the Allen Woolen Mills.)
- Hartford.** C-5. N. Y., N. H. & H. RR. and Cent. N. E. Ry.
- CHENEY BROS.** See So. Manchester.
- HITCHCOCK & CURTISS KNITTING CO.;** (K) \$13,000; E. P. Curtiss, pres. treas. see and buyer; W. A. Blood, supt; Wool, Worsted and Silk Mittens, Bicycle and Athletic Hose; (buy wool and worsted yarns); 75 knitting machines; steam; sell direct.
- KAYSER, JULIUS, Co.;** (of Brooklyn, N. (K) Y.); Asylum St; Silk Gloves, Silk and Merino Underwear; 90 knitting machines; steam; dye; sell direct. (Branch mill.)
- PARK KNITTING WORKS;** Plaisted & Bar (K) ton; Fine and Medium Gloves, Mittens, Fine Seamless Sweaters, Bicycle Hose, Golf Hose and Leggings from Scotch Mixtures; (buy worsted yarns, 4/16x4/26, rovings, 2/4s, 2/3s, 2/2s); 25 knitting machines steam; sell direct; 336 Asylum St.
- Hazardville.** A-6. N. Y., N. H. & H. RR.
- GORDON BROS.;** Shoddy; 25 cards; 1 (W) pickers; steam and water; dye.
- Higganum.** D-6. N. Y., N. H. & H. RR.
- RUSSELL MFG. CO.** See Middletown.
- Jewett City.** D-8. N. Y., N. H. & H. RR.
- ASHLAND COTTON CO.;** \$100,000; A. H. (C) Brewer, pres.; J. O. Sweet, treas. and agt; A. R. Young, supt; Satens, Cambries and Twills; 10,272 ring and 13,528 mule spindles; 600 looms; water and steam; sell direct; J. O. Sweet and J. A. Owen, buyers.
- ASPINOOK CO.;** \$500,000; Moses (Pr D & H) Pierce, pres.; O. L. Johnson, Jr, treas. and mgr.; A. McNicol, supt; Print, Bleach and Dye Cotton Fabrics; steam and water; O. L. Johnson, Jr, buyer.
- BURLESON, A. B. & Co.;** Fine Yarns; (C) gasoline; sell direct; E. F. Burleson, buyer. (Buy Carded, Sea Island and Combed Peeler Cops.)

- SLATER, W. A., MILLS: C. D. Turnbull, (C atty.; Frederick D. Ballou, supt.; Yarns, 20s to 50s; 25,000 ring spindles; water and steam; sell direct; Boston office, 85 State St.
- Killingly.** B-9. N. Y., N. H. & H. RR. See also Ballouville, Danielson and East Killingly.
- ATTAWAUGAN Co; Attawaugan Mill; (C \$600,000; W. H. Blackstone, treas.; C. H. Frisbie, agt; C. H. Truesdell, supt. and buyer; Sheetting, Shirting, Leno, etc; 21,000 spindles; 496 looms; water and steam; C. O. Burch, N. Y., s. agt; also mills at Ballouville and Montville.
- DAVIS & BROWN WOOLEN Co; Thibets (W and Cheviots; 5 sets; 27 looms; Greely, Cushman & Record, s. agts.
- DAYVILLE WOOLEN Co. (Inc. 1894); (W \$50,000; Charles Bard, pres.; Kerseys, Cloakings and Overcoatings; 12 sets; 70 looms; steam and water. (In hands of receiver Mar., '02.)
- MASHENTUCK MILLS; Willis Bartlett, (W agt.; (P. O. Box 83) steam and water. (To be converted into woolen mills.)
- SMITH, FRED R.; C. D. Chase, supt.; (W Cotton Warp Dress Goods; 2 sets; 28 looms; steam and water; dye; Lawrie, Mann & Drowne, N. Y., s. agts; Fred R. Smith, buyer.
- THAYER WOOLEN Co; Daniel Beaumont, (W supt; Satinets; 4 sets; 56 looms; steam and water. (Also see No. Oxford, Mass.)
- WILLIAMSVILLE MFG. Co, THE; \$200,000; (C J. A. Atwood, pres; H. C. Atwood, treas, agt., and supt; Shirtings; 10,496 ring and 13,680 mule spindles; 648 looms; steam and water; Treat & Converse, s. agts; W. E. Atwood, buyer.
- Ledyard.** E.S. See Shewville.
- Long Hill.** F-2. N. Y., N. H. & H. RR; Berk. Div.
- RADCLIFFE, C. E.; Cotton and Wool (K Fleece Linings for Rubber and Glove Manufacturers, and Eiderdown; 1 set; 6 knitting machines; steam and water; dye.
- Manchester Green.** C-6. Station Manchester, on N. Y., N. H. & H. RR.
- GLASTONBURY KNITTING Co; \$40,000; (K Hewitt Coburn, Jr, pres; J. W. Halstead, treas; Men's Fine Merino and Wool Knit Underwear, 3 sets; 13 knitting machines; steam; dye; sell direct, 346 Broadway, N. Y. (also mill at Addison, Ct, which is head office.)
- Mansfield Centre.** C-7. Stage at Willi mantic, on N. Y., N. H. & H. RR, and Cent. Vt. RR.
- CHAPPEE, O. S. & SON; Sewing Silk and (S Twist; 900 spindles; steam and water.
- MACFARLANE, J. S.; James Lloyd Mac. (S Farlane, supt.; Sewing Silk and Twist; 1500 spindles; water; dye.
- Mechanicsville.** A-9. N. Y., N. H. & H. RR.
- FRENCH RIVER TEXTILE Co; \$100,000; (W Frank A. Sayles, pres.; Alfred M. Coats, treas.; C. F. Waterman & Geo. P. Newell, agts. and mgrs.; F. Crook, supt.; Fine Worsted and Wooleens; 17sets; 101 looms; water; dye; Cooley, Turnbull & Co.; s. agts.
- Meriden.** D-4. N. Y., N. H. & H. RRs.
- INDEPENDENT THREAD Co. Failed. *Out of business.*
- MERIDEN CURTAIN FIXTURE Co.; \$40, (C 000; D. W. Parker, treas.; W. D. Harned, supt.; Shade Cloth, Fringes; (buy yarn, 12/2, 12/3, 26/2, 40/3); steam; dye; also bleaching; Columbia Shade Cloth Co; Boston, Phila, Chicago, Detroit, St. Louis and N. Y., s. agts.; W. D. Harned, buyer.
- RAWITSER & BRO; Meriden Woolen (W Mill; Otto Scharegge, supt; Ladies' Dress Goods, Cloaking and Suiting; 13 sets; 2 Noble combs; 1000 worsted spindles; 2 sets worsted; 93 looms; steam; dye; sell direct. (Mills also at Mystic, Stafford Springs, Staffordville and Brooklyn, N. Y.)
- Middletown.** D-5. N. Y., N. H. & H. RR, Hart, Val. and Air Line Divs.
- ARROWANNA MILLS; I. E. Palmer, prop; (C John G. Palmer, supt; Crinoline Linings, Mosquito Netting, Hammocks, Willow Screen Cloth; 100 looms; water and steam; dye; sell direct.
- L. D. BROWN & SON Co, THE; \$150,000; (S O. Vincent Coffin, pres; Seward V. Coffin, treas; J. B. Hubbard, supt; Machine Twist, Sewing Silk, Floss, Linings, Dress Silks, Etc; 6,000 spindles; 120 looms; steam; dye; sell direct; Salesroom, 840 Broadway, N. Y.; S. V. Coffin and J. B. Hubbard, buyers.
- PORTLAND SILK Co; \$100,000; Charles G. (S Taylor, pres. and buyer; H. Vogel (N. Y.), treas; James Miller, supt.; Broad Silks; 500 looms; steam; Chas. G. Taylor, 476 Broome St., N. Y., s. agt.
- ROCKFALL WOOLEN Co; \$25,000; (Inc. (W 182); Bernard F. Merriam, pres; Jos. Merriam, sec. and treas.; S. S. Stiles, supt; Horse Blankets; (buy cotton warps, 20/2, 24/2 in beam and skeins); 5 sets; 32 looms; steam and water; dye; Allen Lane Co, N. Y. and Boston, s. agts; Jos. Merriam, buyer.
- RUSSELL MFG. Co; \$900,000; E. K. Hub. (C bard, pres; W. C. Fisher, treas; E. L. Bailey, agt; F. H. Frimel, supt; Elastic and Non-Elastic Web; 15,000 ring spindles; 600 looms; water and steam; dye; sell direct, and Townsend & Longmire and Marden, King & Crede, s. agts. (Also see North Wales, Penn.) E. K. Hubbard, buyer.
- Montville.** E-S. Cent. Vt. RR. See also Oakdale and Uncasville.
- PEQUOT MILLS, of the Attawaugan Co; (C \$600,000; Wm. N. Blackstone (Norwich), treas; J. P. Rathburn, supt; Dress Goods, Sheefings and Prints; 9320 spindles; 236 looms; steam and water; Creighton & Burch, s. agts. (See also Killingly.)
- MONTVILLE WOOLEN Co.; P. H. O'Keefe, (W agt; P. F. Walsh, supt.; Cassimeres, Cheviots, Overcoatings; 4 sets; 19 looms; steam and water; dye; Schefer, Schramm & Vogel and Fieitmann & Co., N. Y., s. agts.; P. H. O'Keefe, buyer.
- SCHOLFIELD, C. F.; Brookside Mill; (W Flannels and Wadding; 1 set; 3 looms; water. (Mill idle; for sale.) P. O. address, Oakdale.
- Moodus.** D-6. N. Y., N. H. & H. RR, Val. Div.
- BROWNELL & Co; C. E. Brownell, pres., (C treas; agt; Seime and buyer; Hard, Medium and Soft Laid Seime Twine; 2800 spindles; water; sell direct.
- CHACE MILL, THE; Hall, Lincoln & Co., (C owners (formerly A. B. Chace); H. B. Fielding, Jr. supt.; Fine Yarns and Thread; 3296 spindles; steam and water; sell direct.
- JOHNSON, E. EMORY; Neptune Mills; (C Seime Twines, Cable Cords, No. 10 Yarn, and Hammock Goods; 2500 spindles; water; sell direct. Mills at Johnsonville.
- NEW YORK NET & TWINE Co.; \$120,000; (C Eugene W. Chaffee, pres.; Arthur W. Chaffee, treas.; Seime Twine and Fish Nets; 2911 ring spindles; 10 machines for knitting netting; water; sell direct; 103 Barclay St. N. Y.; E. W. Chaffee, buyer.
- PURPLE, A. E.; Undine Twine Co; Seime (C Twine and Sall Twine; 464 spindles; water; sell direct.

- WILLIAMS DUCK MILL;** Hall, Lincoln & (C Co., owners; Sidney M. Barry, supt. and buyer; Cotton Duck and Sail Twine; 1350 ring spindles; 40 looms; water; Hall, Lincoln & Co, 154 Milk St., Boston, s. agts.
- Moosup.** C-9. N. Y., N. H. & H. RR.
- ALDRICH MFG. CO;** Union Mills; H. L. (C Aldrich, pres; C. T. Aldrich (37 Weybosset St., Prov., R. I.), treas; W. J. Cray, supt.; Lawns, Satens and Sheetings; 16,886 ring and 19,360 mule spindles; 800 looms; water and steam; sell direct; 37 Weybosset St., Prov.
- CRANSKA, FLOYD;** Combed Cotton Yarns (C for Thread and Hosiery trade; 5120 ring spindles; water and steam; sell direct. (Also Worcester, Mass.)
- MOOSUP MILLS (American Woolen Co.);** (W Wm. M. Wood, treas; John R. Hinchcliffe, resident agt; Fancy Cassimeres and Worsted; 14 sets; 5500 worsted spindles; 125 looms (English system); steam and water; dye; J. Clifford Woodhull, 74-76 Worth St., N. Y., s. agt.; H. J. Potter, buyer.
- Mt. Carmel.** E-4. N. Y., N. H. & H. RR; Northampton Div.
- CLARK, H. D.;** Cotton Braids, also Silk (S Floss and Tram; 300 spinning spindles; 70 braiding spindles; water; sell Tram and Floss direct; Butzel & Heisenberg, s. agts.
- Mystic.** F-9. N. Y., N. H. & H. RR, Ston. Div.
- BARBER, L.;** Fish Lines, Maitre Corals, (C etc.
- MYSTIC MFG. CO.;** \$50,000; H. A. Crowther, (W pres.; Eli Gledhill, treas., supt., and buyer; Fine Worsted suitings and Trouserings; (buy worsted yarns); 30 looms; steam; dye; Folkhard & Lawrence, 725 Broadway, N. Y., s. agts.
- MYSTIC TWINE CO.;** Randall Browne; (C Isaac Cundall, supt.; Steam Tarred Lines, Maitre Cord, Gangings, etc; steam; sell direct; Randall Browne, buyer; (buy 6 to 20 cotton yarn).
- RAWITZER & BRO.;** John Kennedy, supt; (W Fancy Cassimeres, Chinchillas and Unions; 7 sets; 70 looms; steam; dye; sell direct; buy cotton warps, 16s and 20s single, and 30s two-ply. (Also Meriden, Stafford Springs, Staffordville and Brooklyn, N. Y.)
- ROSSIE VELVET CO. (of Suechtein, Prus. (S sia);** Silk Velvets. Openhym & Sons, cor. Mercer & Grand Sts., N. Y. City.) s. agts.
- Naugatuck.** E-3. N. Y., N. H. & H. RR, Naug. Div.
- DUNHAM HOSEIERY CO.;** \$50,000; A. C. Dun (K liam, pres; S. G. Dunham, treas; D. P. Mills, agt., supt., and buyer; Underwear, Sweaters, Fine Cotton Net and Jersey Cloth for Rubber Shoe Trade; 7 sets; 81 knitting machines; steam and water; dye; sell direct and A. S. Haight & Co., N. Y. s. agts; (buy Egyptian and Peeler combed 14 to 35 yarn).
- New Boston.** A-9. Station at Quinebaug, on N. Y., N. H. & H. RR.
- MURDOCK, GEO. T. & SONS.;** Satinets (W and Narrow Cotton Warp Goods; 5 sets; 70 looms; water; Stevens, Sanford & Handy, N. Y., s. agts; buy cotton No. 18, 1,200 ends.
- New Britain.** C-4. N. Y., N. H. & H. RR, N. Y. Div.
- AMERICAN HOSEIERY CO.;** \$300,000; Jno. B. (K Talcott, pres. and treas.; E. H. Davison, sec. and supt.; Cotton, Woolen and Silk Fashioned Hosiery and Underwear; steam; dye; Jas. Talcott, N. Y., s. agt.
- LINEN UNDERWEAR CO.;** David M. Ran- (K ken and others; Linen Underwear.
- NEW BRITAIN KNITTING CO.;** \$150,000; Jno. (K B. Talcott, pres; J. Fred'k. Talcott, treas.; Wool, Worsted, Egyptian and American Cotton Full Fashioned and Flat Knit Underwear; 14 sets; 2800 spindles; 146 heads; 60 fashion knitting machines; steam; dye; N. Y. office, 258 Church St.
- New Hartford.** B-3. Cent. N. E. RR, and N. Y., N. H. & H. RR, No. Div.
- MT. VERNON WOODBERRY COTTON DUCK (C Co. (Greenwoods Division);** Walter M. Smith, treas; Duck Awnings, Paper Felts, Belting, etc.; 23,000 ring spindles; 400 looms; steam and water; dye; J. Spencer Turner Co., N. Y., s. agts.; (buy 6, 8, 10, 12, 18, 24 and 26 yarn.)
- New Haven.** F-4. N. Y., N. H. & H. RR.
- GLENDORA KNITTING CO.;** 1049 State St; (K \$12,000; R. A. Brown, pres; Geo. A. Saunders, sec. and treas; Hart Scanton, supt.; Seamless Cotton Half Hose, including Lises; 60 machines; steam; sell direct; N. Y. office, 396 Broadway. (Buy 12/1 and 22/1 Carded Peeler and 24/2 Combed Egyptian Lisle Twist.)
- GLOBE SILK WORKS;** Marvin & Pardee; F. (S Broadhurst, supt.; Machine Twist, Embroideries, all kinds Spun Silks and Silk Braids; 2500 spindles; steam; dye; sell direct. Offices, 134 Summer St., Boston, and Gloversville, N. Y.
- NEW ENGLAND WARP CO.;** \$5000; W. (C & D W. Post, pres. and treas; T. H. Matthews, supt; High Grade Cotton Warps, Skein Dyeing and Bleaching; steam; dye; sell direct.
- NEW HAVEN WEB CO.;** \$60,000; Henry L. (C Hotchkiss, pres; Archer Smith, treas; B. A. Mann, supt; Elastic and Non-elastic Webbing and Braids; 500 braiders; water and steam; dye; The American Mills Co., s. agts.
- POND LILY CO. THE.;** \$50,000; Wm. (B & D H. Forsythe, pres; W. C. Harmon, treas; Wm. Watson, supt; Dyers Cotton Piece Goods, Hosiery and Yarns; steam and water; dye; Wm. H. Forsythe, buyer.
- POND LILY WARP CO.;** \$10,000; Wm. H. (C & D Forsyth, pres; Sherman F. Foote, treas; Dye Cotton Yarns, Fast Blacks, Logwood and Colors, Warps on Jack Spools and Beams; steam and water; dye; Walter F. Slade Co., s. agts. (Purchased warp business of Pond Lily Co.)
- WASHBURN, E. L.;** 81 Church St; (K Elastic Hose, Surgical Goods; 2 knitting machines.
- WHITING, LEROY E.;** Whiteknit Mills; (K Seamless Cotton Half Hose; 31 knitting machines; steam; dye; Martin Mfg. Co., s. agts. (Buy 7 to 30s yarn.)
- Newington.** C-5. N. Y., N. H. & H. RR. (5 m. from Hartford.)
- NEWINGTON KNITTING WORKS.;** John W. (K Crane, prop.; W. H. Bacon, supt.; Fine Worsted Wool and Silk Knit Goods, Surgical and Athletic Goods a Specialty; Sweaters, Cardigan Jackets, Full Fashioned Silk, Worsted and Golf Stockings; 16 knitting machines; 5 hand looms and 5 special knitting and weaving machines for sundry work; steam; sell direct; John W. Crane, buyer.
- New London.** E-8. N. Y., N. H. & H. RR, and Cent. Vt. RR.
- BRAINARD & ARMSTRONG CO. THE.;** \$640, (S 000; B. A. Armstrong, pres. and treas; Sewing Silk, Wash and Embroidery Threads and Tailor's Linings; 10,000 spindles; 246 looms; steam; sell direct.
- NEW LONDON STEAM WOOLEN MILL CO.;** (W 5 sets; 38 looms; 1300 spindles; steam; dye. (Mill closed indefinitely.)

- NEW LONDON WASH SILK CO;** (Inc.) (\$25,000; C. C. Knowlton, pres. and treas.; Robert Smith, supt. and buyer; Knitting, Crochet, Embroidery Silks, etc; steam, dye; Hammond, Knowlton & Co, N. Y., s. agts.
- PALMER BROS. CO.;** \$500,000; Frank L. (C) Palmer, pres.; Geo. S. Palmer, treas. and supt.; Bed Comfortables; steam and water; sell direct; Wm. H. Palmer, buyer; mills at Bozrah and Montville, Ct.
- PALMER, R. T. CO.;** T. R. Palmer, pres.; R. (C) T. Palmer, Jr. treas.; Bed Comfortables; 113 Worth St., N. Y.
- Norfolk.** A-2. Cent. N. E. Ry.
- AETNA SILK CO.;** \$20,000; Joseph Selden, (S) pres. and treas.; Sewing Silk and Twist; 1600 spindles; water; dye; sell direct; office, N. Y., Phila., Rochester, Chicago and Gloversville.
- NORFOLK & NEW BRUNSWICK HOSIERY (W) Co** 3 sets; water. Main mill at New Brunswick, N. J., to which knitting machinery has been removed. (Not running.)
- No. Grosvenordale.** A-9. N. Y., N. H. & H. RR; Norwich Div.
- GROSVENORDALE CO.;** Wm. Grosvenor (C) (Prov), pres. and treas.; F. M. Messenger, agt.; Sheetings and Sateens; 75,152 ring and 38,400 mule spindles; 3600 looms; steam and water; sell direct. Treas. buys cotton; Agt. supplies and machinery. 2 Mills. Also mill at Grosvenordale.
- No. Windham.** C-S. N. Y., N. H. & H. RR; Mid. Div.
- NO. WINDHAM MILLS.;** E. H. Hall & Son; (C) E. L. Hall, supt.; Cotton Yarns, Double and Twisted for Thread; 2,000 ring, L120 twister and 1,472 mule spindles; water; sell direct; E. H. Hall, buyer.
- SIBLEY, WM.;** Wm. H. Sibley, supt.; (W) Flocks, Woolen Waste, Scouring; 1 set; water; dye.
- Norwalk.** G-1. N. Y., N. H. & H. RR, Danbury & Berk. Div. See also Winnipauk.
- ANDREWS & SMITH WOOLEN CO.;** Wm. F. (W) Wood, supt.; Woolens and Worsteds; 8 sets; 56 looms; steam and water; dye; sell direct; Mr. Andrews, buyer. (Operating plant formerly known as Norwalk & Fairfield Worsted Mills.)
- Norwich.** D-S. N. Y., N. H. & H. and Cent. Vt. RRs.
- BEEBE, CHAS. G. MRS.;** Banding, Clothes (C) Lines, Cords, etc; sell direct.
- CLINTON MILLS CO.;** \$160,000; F. P. Cabot (W) pres.; Amasa Clarke, treas.; A. J. Smith, agt.; Dress Goods; Carriage Cloths; 10 sets; 54 looms; steam and water; dye; Cabot, Jones & Kelly, Worth St., N. Y., s. agts.
- FALLS CO.;** \$500,000; A. H. Brewer, pres.; (C) Wm. G. Ely, treas.; J. F. Reardon agt.; Ticks, Awnings, Ducks, Denims, etc; 23,000 ring spindles; 720 looms, water and steam; dye; Whitman & Phelps, N. Y., s. agts.; J. F. Reardon, buyer.
- HALL BROS.;** Thames Valley Mills; F. (W) B. Hall, supt.; Dress Goods and Cloakings; 4 sets; 20 broad looms; steam and water; Sawyer & Blake, N. Y., s. agts. Also mill at Preston.
- LUCAS, BENJ. & CO.;** N. E. Lucas, supt.; (W) Dress Goods; 4 sets; 28 broad looms; water; dye; Cabot, Jones & Kelley s. agts.; Aaron Lucas, buyer. Mill at Poquetannuck.
- MARTIN, J. B. CO.;** Ltd. \$200,000; A. (S) Martin, pres.; E. H. Crozier, treas. and mgr.; J. Munz, supt.; 85 looms; steam; finish; Wm. Openhym & Son, N. Y., s. agts.
- OSSAWAN MILLS CO.;** \$20,000; E. P. Turner, (C) pres.; Frank C. Turner, treas. and buyer; Picture and Shade Cords; 45 looms; 1000 braiding machines; 500 twisters; water and steam; sell direct. (Buy 1 1/2 medium cotton yarn and Seine Twine, 20 thread, medium Irish).
- OTROBANDO WOOLEN MILL.;** Cassimeres; (W) 10 sets; 56 looms; steam and water; dye. Leased by W. G. Hitchon of Shewville, Conn.
- OWANEO SILK CO.;** E. Oldfield, supt.; (S) Ribbons and Hat Bands; 80 looms; steam; dye; sell direct; N. Y. office, 111 Greene St. (Buy No. 40 and finer yarn.) (See Preston.)
- PONEMAH MILLS.** See Taftville. (C)
- SHANNON, JAMES B.;** Geo. T. Paquette, (K) mgr.; Hosiery; 16 knitting machines; (Capacity 60 doz. per day).
- SHETUCKET CO.;** \$500,000; W. G. Hender (C) son, agt.; Denims, Ticking, Hickory Stripes and other Colored Goods; 25,332 ring spindles; 742 looms; water and steam; dye; Whitman & Phelps, N. Y., s. agts.; W. G. Hender son, buyer. Mill at Greenville.
- TOTOKETT MILLS.;** \$135,000; W. N. Black. (C) stone, treas.; D. Wright, supt.; Sheetings; 16,000 spindles; 280 looms; water; sell direct.
- UNITED STATES FINISHING CO.;** \$3,000,000; (F) J. H. Hart Smith, treas., N. Y.; J. H. Wright, gen'l mgr.; Finishers of Cotton Goods; 12 printing machines; steam and water; dye; main office, 320 Broadway, N. Y.
- Oakdale.** E-S. Station at Montville, on Cent. Vt. RR.
- OKDALE CORDAGE CO.** See Turnerville.
- OKDALE MILLS.;** Massasoit Mfg. Co., (C) Fall River, Mass.; \$100,000; Frank L. Palmer, pres.; Wendell E. Turner (Fall River), treas.; W. S. Richmond, (Oakdale, Conn.), supt. and buyer; Wicking, Mop Yarns, Knit Mops, and Jewelers' and Absorbent Cotton; steam and water; dye; sell direct.
- Packerville.** C-9. N. Y., N. H. & H. RR, Cent. Div.
- CITLER, E. A.;** agt. Packer's Mill; (C) Chas S. Bliven, supt.; Etamines; 500 twisters; 24 looms; water; W. R. Morse & Co, 131 Kingston; Boston, s. agts. (Buy No. 20-22-25 Combed, 40-50-80 Cops, best quality).
- Phoenixville.** B-S. Station No. Windham, N. Y., N. H. & H. RR; Mid. Div.
- WHEATON, SIMEON A.;** Harris Mill; Twine (C) and Carpet Warps; 860 spindles; water *Mill not running. For Sale.*
- Pine Meadow.** B-3. N. Y., N. H. & H. RR, Northampton Div; Cent. N. E. Ry.
- SMITH, D. B. & SON.;** Geo. W. Smith, agt. (C) and buyer; D. B. Smith, supt.; Cotton Duck; 5000 ring spindles; 42 looms; water; sell direct, and J. H. Lane & Co., s. agts.
- Plainville.** C-4. N. Y., N. H. & H. RR, Northampton Div.
- PLAINVILLE MFG. CO.;** Men's, Women's (K) and Children's Flat and fleeced Underwear; 11 sets; 3120 worsted spindles; 75 knitting machines; steam; sell direct. (Consolidated with Bristol Mfg. Co.)
- Poquetannuck.** E-S. See Norwich.
- Poquonock.** B-5. On map as Windsor, which see for RR.
- HEALTH UNDERWEAR CO.;** \$30,000; A. C. (K) Dunham, pres.; Henry Osborne, treas.; A. H. Brothers, agt., supt. and buyer; Underwear and Worsted Yarns; 14 sets; 7000 mule spindles; 40 knitting machines; 61 sewing machines; steam and water; dye; and A. S. Haight & Co., s. agts. for underwear.

**Preston.** D.S. Stage 6m at Norwich, on N. Y., N. H. & H. RR.

**HALL BROS;** Hallville Mills; Cassi- (W) meres, Dress Goods and Cloakings; 12 sets; 90 broad looms; steam and water; dye; Oelbermann, Dommerich & Co., N. Y., s. agts.; Hall Bros., buyers; P. O. address Norwich, which see.

**OWANECO SILK CO;** \$60,000; C. P. Cogs. (S) mill, pres; C. A. Capen, sec. and treas; E. Oldfield, supt; Throwing; 5000 spindles; sell direct. Also Norwich.

**Putnam.** B.9. N. Y., N. H. & H. RR, Mid. Div. and Norwich Div.

**CHAPMAN, A. E.** See E. Putnam.

**DADY, J. A. CORPORATION;** John A. (S) Dady, pres. and treas; Silk Twist and Sewings; 7500 spindles; steam. (Branch mill at So. Coventry.)

**HAMMOND, KNOWLTON & CO;** W. E. (S) Holmes, supt; Sewing Silk, Machine and Button Hole Twist and Braids; 4500 spindles; water; dye; G. A. Hammond, buyer; sell direct; salesrooms at 756 Broadway, N. Y., Chicago, Boston, Phila. and Rochester.

**MORSE MILLS;** \$150,000; J. K. H. Nightingale, C gale, treas. (Prov.); Augustus I. Morse, supt; Sheeting and Shirtings, 13,520 spindles; 308 looms; water and steam; Treat & Converse N. Y., s. agts.

**MONOHANSETT MFG. CO;** \$75,000; Geo. (C) W. Holt, pres. and agt; H. J. Thayer, treas; W. F. Holt, supt; Sheatings; 5700 ring and 7520 mule spindles; 306 looms; water and steam; Treat & Converse; N. Y., Boston, Balto. and Phila., s. agts.; Geo. W. Holt, buyer.

**NIGHTINGALE MILLS;** \$150,000; G. C. (C) Nightingale, pres; J. K. H. Nightingale, treas. (Prov.); Augustus Morse, supt; Sheatings and Shirtings; 14,640 spindles; 307 looms; water and steam; Treat & Converse, agts.; J. K. H. Nightingale, buyer.

**POWHTAN MILLS;** \$300,000; Geo. M. (C) Morse, pres. and agt; J. K. H. Nightingale, treas. (Prov.); Augustus Morse, supt; Sheatings and Shirtings; 19,348 spindles; 451 looms; water and steam; Treat & Converse, N. Y., s. agts. J. K. H. Nightingale, buyer.

**PUTNAM MFG. CO;** \$300,000. E. K. Ray (C) (Woolsocket), treas; Geo. A. Vaughan, supt; Sheatings, Satens and Curtain Goods; 35,144 spindles; 850 looms; water and steam; sell direct; Wm. P. Vaughan, Providence, R. I., s. agt.; Geo. A. Vaughan, buyer.

**PUTNAM WOOLEN CO;** \$300,000; C. M. (W) Blake (Boston), pres; E. A. Wheelock, treas; Cassimeres; 19 sets; 88 looms; water; dye; Jacob Wendell & Co., N. Y., and Blake & Stearns, Boston, s. agts.; E. A. Wheelock, buyer, wool; G. H. Brown, supplies.

**Quinebaug.** A.9. N. Y., N. H. & H. RR; Norwich Div.

**STEVENS, EBEN S;** Unions, Twills, Piece (W) Dyes and Satinets; 8 sets; 114 looms; water; dye; Wm. Iselin & Co. s. agts. Also Webster, Mass.

**Rockville.** B.6. N. Y., N. H. & H. RR.

**AMERICAN MILLS CO;** \$100,000; Geo. Tal- (W) cott, pres; C. N. McLean, treas. and buyer; Geo. Schofield, supt; Woolen and Worsted Goods for Men's Wear; 17 sets; 86 looms; steam and water; dye; sell direct and Lawrie, Mann & Drown Co., N. Y., s. agts.

**BARROWS, E. L;** Silk Thread; water. (S) **BELDING BROS. & CO;** \$1,000,000; M. M. (S) Belding, pres; M. M. Belding, Jr, treas; A. N. Belding, agt.; H. L. Allen, supt; Sewing Silk, Machine Twist, Floss, Embroidery Fringe; steam and water; dye; sell direct;

A. N. Belding, buyer. Also mills at Belding, Mich. and Northampton, Mass.

**HOCKANUM CO;** \$300,000; Geo. Sykes, (W) pres; F. T. Maxwell, sec. and treas; Woolen and Worsted Coatings and Trouserings; 10 sets; 164 looms; steam and water; dye; sell direct, 64 Worth St., N. Y.

**MARTIN'S, E. SONS;** A. L. Martin, supt. (S) and buyer; Braided Fish Lines and Specialties in Fishing Tackles; steam; sell direct.

**NEW ENGLAND CO;** \$240,000; George (W) Sykes, pres; A. Parks Hammond, treas; C. S. Bottomly, supt; Woolen and Worsted Goods; 9 sets; 114 looms; steam and water; dye; Hockanum Assn, s. agts.

**REGAN, JAS. J. MFG. CO. THE;** (CW&K) Stockinets, Pushes; Fleece Linings, Knitting and Hosiery Yarns, Wool Shoddies; Extracts and Flocks; 14,000 cotton spindles; 8 sets; 4 sets woolen; 35 looms; 100 knitting machines; 4 pickers; 3 cutters; 3 garnets; steam and water; dye; sell direct.

**ROCK MFG. CO;** \$200,000; Cyril Johnson, (W) pres; A. T. Bissell, treas; F. Swindells, supt; Finest Worsteds and Wooleens for Men's Wear; 15 sets; 120 looms; steam and water; dye; Schmabel Bros, 71 Worth St. N. Y. s. agts.; F. Swindells, buyer. (Buy 2/20 to 2/50 worsted yarns).

**ROCKVILLE WARP MILLS CO;** \$40,000; (C) Henry Adams, pres. and treas.; F. M. Adams, supt. and asst. treas; Cotton Yarn All Colors and Kind For Woolen and Worsted Mills; 3500 spindles; water and steam; dye; sell direct.

**SPRINGVILLE MFG. CO;** \$250,000; Geo. (W) Sykes, pres; Wm. Maxwell, treas; D. A. Sykes, supt; Cassimeres and Worsteds; 5 sets; 114 looms; steam and water; dye; Hockanum Assn., 64 Worth St., N. Y., s. agts; Wm. Maxwell, buyer.

**Sandy Hook.** E.2. N. Y., N. H. & H. RR; High Div.

**SANDY HOOK WOOLEN CO;** \$5000; James (W) Broadhead, pres; James Broadhead, Jr, treas; Overcoatings; 4 sets; 20 looms; dye; water and steam; sell direct.

**Seymour.** E.3. N. Y., N. H. & H. RR, Naug. Div.

**TINGUE MFG. CO., THE;** \$200,000; Wm. J. (W) Tingue, pres; Chas. Comlund, treas, agt. and supt; Mohair Pushes and Worsted Yarns; 4 combs; 3700 worsted spindles; 45 looms; steam and water; dye; Tingue, Horse & Co., 84 and 86 Reade St., N. Y., s. agts.

**Shelton.** F.3. N. Y., N. H. & H. RR. 3 m. from Derby Junction.

**ADAMS, R. F;** Derby Cotton Mills; (C) Chas. A. Sweet, agt. Linings and Mosquito Nettings; 12,900 spindles; 332 looms; water and steam; dye; sell direct; 18 Walker St., N. Y.

**BENTLEY BROS.;** J. W. Bentley, supt. (W) and buyer; Blankets, 1 set; 3 looms; water; dye; sell direct; (buy warps No. 14, and 3 run wool yarn.)

**BLUMENTHAL, SIDNEY & CO;** (Inc) Vel. (S) vets; 200 looms; sell direct, 10 & 12 Greene St., N. Y.

**RADCLIFFE BROS.** (Inc. 1892) \$60,000; (K) W. W. Radcliffe, pres; F. W. Radcliffe, treas; Knit Wool Underwear and Half Hose; 8 sets; 160 knitting machines; steam and water; dye; sell direct.

**SPECIALTY WEAVING CO;** E. Weibel, supt; (S) Silk Ribbons; 60 looms; water; sell direct; S. Blumenthal, 10 Greene St., (N. Y.) buyer.

**Showville.** E.8. 6m S. E. of Norwich, Cent. Vt, New London Div. and N. Y., N. H. & H. RR; Norwich and Wor. Div.

- GLEN WOOLEN MILLS THE; W. G. (W) Hitehon, supt; Cassimeres, etc; 2 sets; 12 looms; water and steam; dye; Oelbermann, Dommerich & Co., N. Y., s. agts. (See also Otrobando Mill, Norwiche.)
- Simsbury.** B-4. N. Y., N. H. & H. RR, Northampton Div, & Cent. N. E. RR.
- Somersville.** A-6. Stage 1m at Hazardville, on N. Y., N. H. & H. RR.
- SOMERSVILLE MFG. CO; \$100,000; Geo. E. (W) Keeney, treas, and agt.; L. Keeney, supt.; Men's Wear; 18 sets; 100 broad looms; water and steam; dye; Metcalf Bros; N. Y., s. agts.; treas. and supt., buyers.
- So. Coventry.** C-7. Cent. Vt. RR.
- DADY, JOHN A. CO.; formerly Mrs. S. A. (S) Boffum; Throwsters; 4500 spindles; steam and water; branch, see Putnam.
- KENYON MILL; Bought by E. A. Tracy; (W) part to be used for manufacturing wool extracts.
- TRACY, E. A.; Thos. P. Flaherty, supt.; (W) Wool Extracts; steam and water; dye; sell direct; E. A. Tracy, buyer.
- WASHBURN, A. & SON; Throwsters; (S) steam and water.
- WOOD, T. H.; Braided Silk Fish Lines; (S) 800 spindles.
- So. Glastonbury.** C-5. Station Rocky Hill, on N. Y., N. H. & H. RR, Val. Div; electric cars from Hartford. See also Glastonbury.
- GLAZIER, FRANKLIN & SON; Hopewell (W) Mill; Chas. F. Strunz, supt; Dress Goods and Cloakings; 46 looms; steam and water; dye; Fleitmann & Co, 490 Broome St., N. Y., s. agts.
- So. Manchester.** C-6. So. Manchester RR.
- CHENEY BROS; \$1,000,000; K. D. Cheney (S) pres; F. W. Cheney, treas; Silks, Satins, Dress Goods Plushes, Printed Silks, Pongees, Spun Silk Yarns and Fabrics, Ribbons, Organzines and Trams; steam and water; dye; sell direct. Also Hartford.
- So. Willington.** B-7. Station at Tolland, on Cent. Vt. RR.
- HALL, GARDINER, JR, & CO; Spool Cot. (C) ton; steam and water; dye; sell direct, 59 Walker St., N. Y.
- So. Woodstock.** A-9. Stage 4m at Putnam, on N. Y., N. H. & H. RR.
- WILLIAMS, A. & Co; Sprucedale Mill; (C) A. H. Williams, supt.; Hosiery Yarns, Cop Skeins, Cones and Tubes, also Cotton Bats; 1200 mule spindles; water and steam; sell direct; Arthur Williams, buyer.
- Stafford.** A-7. Cent. Vt. RR.
- PHOENIX WOOLEN CO; \$45,000; E. C. (W) Pinney, pres; E. H. Pinney, treas, and sec; Christopher Allen, vice-pres; C. B. Pinney, agt; Kerseys and Overcoatings; 5 sets; 35 broad looms; steam and water; dye; Jas. Talcott, s. agt.
- RIVERSIDE WOOLEN CO; \$50,000; E. C. (W) Pinney, pres; E. H. Pinney, treas; C. B. Pinney, agt, and buyer; Wm. Lee, supt; 8 sets; 34 broad looms; steam and water; dye; Jas. Talcott and J. Wendell & Co, N. Y., s. agts.
- Stafford Springs.** A-7. Cent. Vt. RR; (N L. N. Div).
- CENTRAL WOOLEN CO; \$50,000; Cyril (W) Johnson, pres, and agt; Wm. O. Rockwell, treas; O. L. Stenderhauf, supt; Fancy Cassimeres and Cloakings; 7 sets; 42 broad looms; steam and water; dye; Jacob Wendell & Co; N. Y., s. agts.
- ELLIS, J. J. & A. D.; J. P. Hanley, (W) supt; Kerseys and Venetians; 3 sets; 12 looms; steam and water; dye; Jas. Talcott, and Sullivan, Vail & Co., N. Y., s. agts.; J. J. Ellis, buyer supplies; A. D. Ellis, wood, etc.
- FAULKNER WOOLEN MILLS; Frederiek (W) Faulkner; Adolph Pfeiffer, supt; Ladies' Goods and Men's Wear; 7 sets; 37 looms; steam and water; dye; C. A. Aufmordt & Co., H. W. T. Mali & Co., Schnabel Bros, s. agts.
- MULLEN, T. F. & Co., Forest Mills; (W) Union Cassimeres; 3 sets; 30 looms; steam and water; dye; Converse, Stanton & Co, N. Y., s. agts; (buy No. 16 white).
- RAWITZER & BRO; Shoddy and Flocks; (W) 6 pickers; dye.
- RAWITZER & BRO; River Mills; Repel- (W) lents, Skirtings and Shirtings; 9 sets; 48 broad, 50 narrow looms; steam and water; dye; sell direct.
- SMITH & COOLEY; Shoddy and Flocks; (W) 23 cards; 5 cutters; 4 pickers; steam and water; dye; sell direct; W. H. Cooley, buyer.
- STAFFORD WORSTED CO; \$50,000; Edwin- (W) Wilcock, pres; W. R. Cordingly, treas; Edwin Farnell, agt, and buyer; Walter Scott, supt; Worsted Yarns; 5 cards and 4 combs; 3000 spindles; steam; sell direct; Boston office, 570 Atlantic Ave.
- WARREN WOOLEN CO, THE; J. H. Val- (W) entine, pres; Hamulbal Alden, treas; Peter Scott, supt; Worstedes, Kerseys and Cassimeres; 8 sets; 64 worsted looms; steam and water; dye; Fred'k Viotor & Aehelis and Schnabel Bros, N. Y., s. agts. J. H. Valentine, buyer; (buy yarns of different numbers.)
- Staffordville.** A-7. In Stafford, on Cent. Vt. RR.
- RAWITZER & BRO (Home Mill); Cassi- (W) meres; 3 sets; 32 looms; steam and water; dye.
- STAFFORDVILLE WOOLEN CO; \$32,000; (W) J. H. McCarthy, pres, and supt; W. P. Peel, treas, and agt.; Kerseys and Cassimeres; 2 sets; 25 broad looms; water and steam; dye; Bacon & Co., s. agts.; J. H. McCarthy, buyer.
- SUMMIT WOOLEN CO, W. H. Coe, pres. (W) and treas; Saml P. Morris, supt; Cassimeres; 4 sets; 17 broad looms; steam and water; dye; Lawrie, Mann & Drownie, s. agts; W. H. Coe, buyer.
- Stamford.** H-1; N. Y., N. H. & H. RR, N. Y. Div, and New Canaan Br.
- BOAS THREAD CO; Arthur E. Boas, (C & S) buyer; Spool Cotton, Glazed Yarns and Spool Silk; steam; sell direct; N. Y. office, Room 514, Wool Exchange Bldg. (Buy yarns.)
- MIANUS MFG. CO. (Successors to Ripco. (W) Wam Mfg. Co.); \$25,000; Thos. I. Raymond, pres; Fred A. Springer, treas, agt. and supt; Push Lap Robes; 4 sets; 17 looms; water and steam; dye; Wm. Ayres & Sons, Phila., s. agts.; F. A. Springer, buyer.
- Sterling.** C-9. N. Y., N. H. & H. RR, Prov. Div.
- STERLING DYEING & FINISHING CO; (D & F) (U. S. Finishing Co.), Specialty Fast Colors; Cotton Piece Dyeing and Calendering; steam and water; N. Y. office, 320 Broadway.
- Stonington.** F-9. N. Y., N. H. & H. RR, Ston. Div.
- AMERICAN VELVET CO; \$60,000; Silk Vel- (S) vels; 80 looms; steam; A. Wimpfheimer & Bros, N. Y., s. agts.
- CREFELD MILLS. See Westerly, R. I.
- CLARK, Wm. Co. See Westerly, R. I.
- Taftville.** D-S. Station Tafts. N. Y., N. H. & H. RR.
- PONEMAH MILLS; \$2,000,000; E. M. Coats, (C) pres; J. W. Danielson, treas; John Eccles, supt; Fine Fancy Fabrics, Dress Goods and Fine Printing Cloths; 54,304 ring and 63,756 mule spindles; 276 looms; steam, and water; Clarence Whitman & Co, s. agts.



**Talcottville.** B-6. N. Y., N. H. & H. RR High Div.

TALCOTT BROS; H. G. Talcott, agt; M. (W) H. Talcott, buyer; Union Cassimeres; 6 sets; 60 looms; steam and water; dye; Sawyer & Blake, Boston and N. Y., s. agts. (Buy yarn).

**Tariffville.** B-4. Cent. N. E. RR.

TARIFFVILLE LACE MANUFACTURING CO. (C THE); (successors to Frank Wilkinson Mfg. Co.), \$50,000; Fred Jones, pres. agt. and supt; Chas. A. Ensign, treas; Lace Curtains, Fish Nets, Bed Sets, etc; water; sell direct. (Buy 24/2 to 50/2 carded and 2/60 to 2/100 combed yarn.)

**Thompsonville.** A-5. N. Y., N. H. & H. RR; Hart Div.

HARTFORD CARPET CO; \$5,000,000; R. P. (W) Perkins, pres; Geo. S. Squire, treas; O. M. Beach, sec; Moquette, Axminster, Wilton, Brussels, 3-ply and 2-ply Carpets; 76 sets; 36 combs; 700 looms; steam; dye.

**Tolland.** B-6. Cent. Vt. RR.

SUMNER, WM. BELTING CO; W. A. Agard, (C pres; E. S. Agard, treas; Cotton Leather Belting and other Specialties; steam.

**Torrington.** B-3. N. Y., N. H. & H. RR, Naug. Div.

WARRENTON WOOLEN CO, THE; \$50,000; (W) G. D. Workman, pres; John Workman, treas; S. C. Workman, sec; John R. Jones, supt; Uniform Cloths, Doe Skins and Broadcloths; 5 sets; 20 looms; steam and water; dye; sell at N. Y. office, 85 Leonard St.

**Turnerville.** D-7. N. Y., N. H. & H. RR, New Lon. Div.

CONNECTICUT TWINE & CORDAGE MAN- (C) FACTORY; John J. Oitenheimer, prop; Twine and Cordage; (capacity 3500 lbs. twine per week); sell direct.

OAKDALE CORDAGE CO; \$10,000; John (C) & S. T. Brown, pres, treas, and supt; Sash, Bell and Picture Cord, etc.; water; sell direct.

PALMER, J. E; twine mill. See Middle. (C) town.

THOMPSON BROS; Yarn; 350 spindles; (C) water; sell direct.

TURNER, P. W., & Co; Ribbons, Tie Silks (S) and Commission Throwing; 3000 spindles; 36 looms; water; dye; sell direct.

**Uncasville.** E-8. Station Montville, on Cent. Vt. RR.

UNCASVILLE MFG CO; \$100,000; Chas. D. (C) White, treas, and agt; Frank Grover, supt; Fancy Shirts, Chevots and Denims; 14,000 spindles; 375 looms; steam and water; dye; sell direct.

**Unionville.** C-4. N. Y., N. H. & H. RR Northampton Div.

BROADBENT, J., & SON; J. D. Horsfall, (C&W) supt; Cotton Batts, Hosiery Yarn and Shoddy; 7 systems on batts; 3 sets on yarn; 2 pickers; water and steam; sell direct; Fred J. Broadbent, buyer.

**Vernon.** B-6. N. Y., N. E. & H. RR; High Div.

RAVINE MILLS CO; \$50,000; W. Campbell, (C) pres; R. B. Parker, treas; John D. Parker, supt; Warps, Yarns, Sail, Seine and Sewing Twines; 3600 spindles; water and steam; dye; sell direct.

VERNON WOOLEN CO., THE; \$10,000; E. C. (W) Hilliard, pres; M. H. White, treas, and supt; Union Cassimeres; 6 sets cards; 36 narrow and 18 broad looms; steam and water; dye; Schnabel Bros, N. Y., s. agts. (Buy yarn).

**Versailles.** D-8. N. Y., N. H. & H. RR; Cent. Div.

UNCASVILLE MFG. CO; branch of mill at Uncasville, Ct, which see.

**Voluntown.** D-9. Stage 7 miles at Jewett City, on N. Y., N. H. & H. RR.

BRIGGS MFG. CO, THE; Beechdale Mills; (C) \$100,000; Geo. T. Briggs, vice pres, and agt.; John N. Lewis, treas; Geo. W. Briggs, supt; Sateens, Twills, Cotton Yarns, Warps and Threads; 14,000 ring and 3,000 mule spindles; 124 looms; steam and water; also electricity; dye; sell direct mostly; Geo. T. Briggs and John N. Lewis, buyers; also have mill at Rockville, R. I.

GRISWOLD COTTON MILL CO, THE; \$100, (C) 000; L. W. Carroll (Norwich), pres; Adams P. Carroll (Norwich), treas; D. A. S. Money, supt; 60x56 Print Cloths; 6,000 ring and 6,000 mule spindles; 280 looms; water and steam; sell direct; L. W. Carroll, buyer. (Mill idle since July, 1896)

**Wallingford.** E-4. N. Y., N. H. & H. RR.

NEW YORK INSULATED WIRE CO; \$500,000; (C) C. H. Wilcox, pres; R. F. Herrick, Boston, treas.; R. E. Gallaher, (N. Y.) sec.; Walter Hill, supt; Insulated Wires and Cables, Tapes, etc; 308 braiders; steam; sell direct (15 Cortlandt St, N. Y.). Buy 108, 208-128, 88, hard, soft, white and some colored yarns on tubes.)

**Warehouse Point.** A-5. N. Y., N. H. & H. RR, Hart Div.

WAREHOUSE POINT SILK CO; \$200,000; J. (S) H. Simonds, pres, and treas; Sewing and Machine Silks, Floss and Embroideries; steam; dye; sell direct; R. H. Simonds, buyer.

**Waterbury.** D-3. N. Y., N. H. & H. RR, Naug. Div.

AMERICAN MILLS CO; Earl Smith, pres; (C) Archer J. Smith, treas; Elastic Webs; water and steam; dye; sell direct; Arthur J. Smith, buyer. (Buy 8 to 80 yarn.)

**Watertown.** D-3. N. Y., N. H. & H. RR Naug. Div.

HEMINWAY & BARTLETT SILK CO; \$75,000; (S) Buell Heminway, pres, and treas; H. H. Bartlett, supt; Sewing Silk, Twist, Art Embroidery Silk, Crochet Silk and Special Silk for Manufacturers; 2074 spindles; steam; dye; sell direct; B. Heminway, buyer.

HEMINWAY, M., & SONS SILK CO; Em- (S) broidery, Knitting and Crochet Silks, Machine Twist, etc; sell direct.

**Waterville.** D-3. N. Y., N. H. & H. RR, Naug Div.

WELCH, H. L. HOSEIERY CO; \$80,000; (K) Fred'k Samson, pres; F. B. Buck, treas; L. Gates, agt. and supt; Men's, Women's and Children's Knit Underwear; 2 sets; 720 spindles; 75 knitting machines; 50 sewing machines; steam and water; sell direct N. Y. office, 43 Leonard St; (buy 14s to 80s yarn, Am. & Egyptian carded and combed copes and cones.) Louis Gates, buyer.

**Wauregan.** C-9. N. Y., N. H. & H. RR, N. & W. Div.

WAUREGAN CO, \$600,000; Royal C. Taft, (C) pres; J. W. Danielson, Prov.) treas; J. A. Atwood, agt; J. W. Atwood, supt, and buyer; Fine Lawns and Fancy Goods; 27,792 ring and 31,104 mule spindles; 164 looms; water and steam; sell direct and C. Whitman & Co., N. Y., s. agts.

**Westport.** G-1. N. Y., N. H. & H. RR, N. Y. Div.

LEES MFG. CO; \$50,000 Rob't. T. Lees, (C) pres; J. E. Lees, treas, and agt; John A. Lees, supt; Cords, Twines and Wicks of Every Description; 5000 twisting spindles; water and steam; dye; buy yarn; sell direct, 320 B'dway, N. Y.; James E. Lees, buyer.

Map of

# VIRGINIA, WEST VIRGINIA, MARYLAND, DELAWARE & DISTRICT OF COLUMBIA.

## Showing the Textile Mill Towns.

Specially engraved for the Textile World.

Scale 50 Miles to each Square.  
Copyright, 1893, by Cassie & Luch, Boston.

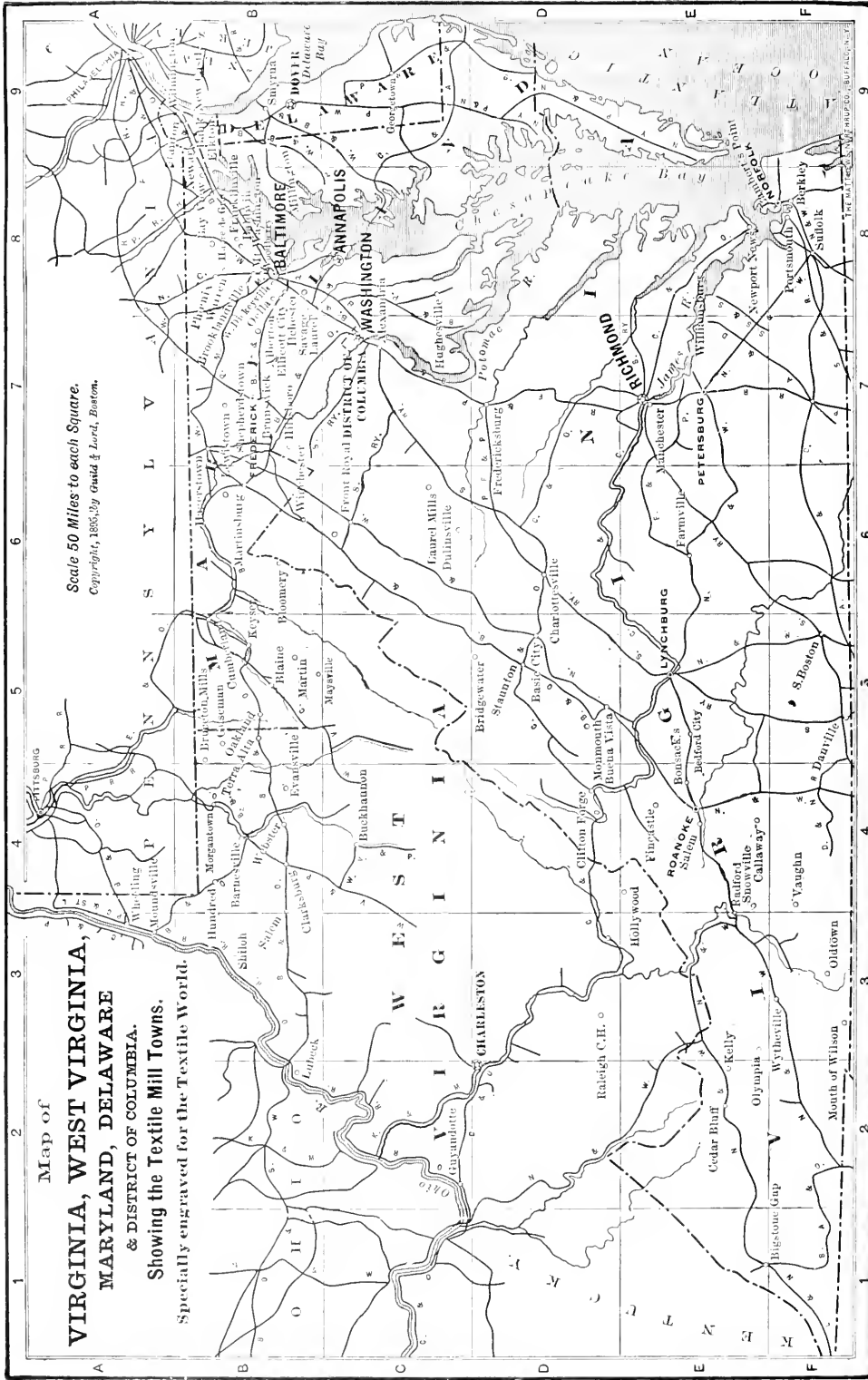

**West Winsted.** B.3. Cent. N. E. RR.

SALTER SILK CO; \$25,000; A. H. Liver. (S more, pres; Eugene Potter, treas; Spool, Embroidery, Twist and Knitting Silks; 1600 spindles; steam; dye; sell direct.

WINSTED SILK CO; \$145,000; Eugene (S Potter, pres, and treas; Sewing Silk, Twist, Knitting and Embroidery Silk; steam; dye; sell direct.

**Wilsonville.** A.9. N. Y, N. H. & H. RR, Nor. Div.

KEEGAN, LAWRENCE; Fancy Cassi. (W meres; 3 sets; 16 looms; dye; Joseph & Werner, N. Y., s. agts.

**Willington.** B.7. See So. Willington and East Willington.**Willimantic.** C.7. N. Y, N. H. & H. RR, and Cent. Vt. RR.

CHAFFEE, A. D.; Silk, Cotton, Worsted and (S Mohair Braids and Cords; 400 braiders; 10,000 spindls; steam; D. E. Adams, 77 Greene St, N. Y, and 111 Channey St, Boston, s. agts; J. D. Chaffee, buyer. (Buy cotton yarns 2/20 in skeins and 2/40 mercerized in skeins.)

HOLLAND MFG. CO; S. L. Burlingham, (S agt, and buyer; Machine Twist, Sewing Silk; 3,772 spindles; steam; dye; sell direct, 561 Broadway, N. Y, 12 High St, Boston, and 428 Market St, Phila.

POLLACK, M. (135 Wooster St, N. Y.); (C Mercerized Thread and Spool Cotton.

TURNER, A. G.; Lock Box 213; Silk Com. (S mission Throwster; 8000 spindles; steam; sell direct. (N. Y. office, 114 Spring St.) (Branch ml at Colchester.)

WILLIMANTIC COTTON MILLS CORPORA (C TION; J. R. MacColl, pres.; Joseph Mercer, treas. and agt; John S. Pye, supt; Fancy Shirtings, Draperies, Satcens, Lenocs and Twills; \$656 ring and 12,000 mule spindles; 487 looms; steam and water; sell direct and Lorraine Mfg. Co, N. Y., s. agts.; Joseph Mercer, buyer.

WILLIMANTIC LINEN CO. (American (C Thread Co.); Lucia A. Barbour, pres. and treas; E. S. Boss, agt; Spool Cotton, 80,000 spindles; steam and water; dye.

WINDHAM MFG CO; \$50,000; Melvin B. (C Borden, pres; W. Frank Shove, sec. and treas; Print Cloths, Twills, Shirtings, etc; 15,000 ring and 5,000 mule spindles; 467 looms; water and steam; sell direct. (Offices at Fall River, Mass.)

WINDHAM SILK CO; \$50,000; H. C. (S Murray, pres; Charles Fenton, sec; W. P. Jordan, treas; Silk Dress Goods and Linings; 50 looms.

**Windsor.** B.5. N. Y, N. H. & H. RR, Hart Div. See Poquonock.**Windsor Locks.** A.5. N. Y, N. H. & H. RR, Hart Div.

MEDLICOTT CO; \$125,000; Chas. E. Chaf (K fee, pres, agt, and treas; N. S. Cooley, supt; Full-Fashioned Knit Underwear; 9

sets cards; water; dye; Knowler & Turn bull, 24 & 26 Thomas St., N. Y., s. agts.; Chas. E. Chaffee, buyer.

MONTGOMERY CO, THE J. R.; \$350,000; (C J. R. Montgomery, pres; Sam'l E. Elmore, treas; Colored and Fancy Cotton Warps and Yarns, Mercerized Cotton Yarns; 17,000 ring spindles; water; dye; sell direct; (bny combed yarn, Sea Island and Egyptian.)

WINDSOR SILK CO; A. H. Bottum, (N. Y.) (S gen. mgr; Spool Silks; Mostly Commission Works; steam and water; dye; A. H. Bottum, buyer.

**Winnipauk.** G.1. N. Y, N. H. & H. RR, Dan & Berk. Div. See also Norwalk.

THE LOUNSBURY & BISSSELL CO, \$200, (W 000; C. C. Betts, pres; E. L. Boyer, treas. and mgr; Felts; 14 sets; steam and water; dye; sell direct; E. L. Boyer, buyer.

NORWALK MILLS CO; \$300,000; John (W A. Osborn, pres; Frederick A. Hill, treas; Thos. J. West, agt, and supt; Overcoat- ings; 12 sets; 55 broad looms; steam and water; dye; Sawyer & Blake, 63 Leonard St, N. Y., s. agts; Thos. J. West, buyer.

**Winsted.** A.3. Cent. N. E. RR; N. Y, N. H. & H. RR. (Naugatuck Div.) See also West Winsted.

EDGEWATER MFG. CO. (See Winsted Silk (S Co, West Winsted.)

NEW ENGLAND KNITTING CO; \$100,000; (K J. E. Spaulding, pres; E. B. Gaylord, treas; L. W. Tiffany, mgr; Men's Wool and Merino Underwear; 10 sets; 3000 spindles; 20 knitting machines; steam; dye; Valentine & Flagler, N. Y., s. agts; L. W. Tiffany, buyer.

WINSTED HOSIERY CO, THE; \$150,000; (K David Strong, pres; E. B. Gaylord, treas. and buyer; Men's Underwear and Seam- less Half Hose; 10 sets; 190 knitting machines; steam; dye; Knitting Mills Trading Co, 104 Franklin St, N. Y., s. agts, underwear; Valentine & Flagler, N. Y. Life Bldg, hose. (Buy 1/20 to 1/32 cotton and 1/17 to 1/45 worsted yarn.)

WINSTED YARN CO; \$7000; L. W. Tiffany, (W gen. mgr; Yarn; 4 sets; 1200 spindles; water.

**Woodbury.** D.2. Stage 7m at Watertown, and Pomerang Valley, 3m. (Highland Div.); on N. Y, N. H. & H. RR

CURTISS, DANIEL, SONS; Diagonals (W and Tricots; 3 sets; 12 looms; steam and water; dye; Fleitmann & Co, N. Y., s. agts.

**Yantic.** D.8. Cent. Vt. RR. Electric cars from Norwich.

YANTIC WOOLEN CO; \$75,000; Benjamin (W Phipps, pres; Winslow P. Williams, treas. agt, and buyer; Dana P. Scribner, supt; Flannels and Dress Goods; 10 sets; 86 broad looms; steam and water; dye; Parker, Wilder & Co, Boston and N. Y., agts.

## DELAWARE.

See map on page 82.

For explanation of abbreviations see page 66.

**Dover.** B.9. P. W. & B. RR.

POST & SHELTON SILK CO; (Branch (S ml); Broad Silks; 60 looms; (Also Paterson N. J.) (In plant formerly operated as Dover Hosiery Mill.)

**Georgetown.** C.9. O. W. & B. RR.

FOOKS, ISAAC N.; Ladies' Ribbed Vests (K and "L. N. F." Child's Waist; 12 knitting machines; 16 sewing machines; steam; sell direct.

**Newark.** B.9. B. & O. RR; Penn. RR; R. W. & B. RR.

ROBERTS, JAMES; Carpet weaver. (W

**New Castle.** B.9. P. W. & B. RR.

KNOWLES, J. G.; WOOLEN CO.; \$125,000; (W Jas. G. Knowles, pres.; M. Knowles, treas.; Cotton Worsted and Woollens; 8 (60-in) sets; 200 looms; steam; dye and finish; sell direct and thro' agts.

- TRITON MILLS, James G. Shaw; Warp (C) Yarns; 13,000 spindles; steam; 140 Chestnut St, Phila, Pa. *Not running.*
- Smyrna.** B.9. A. W. & B. RR.; B. & O. RR.
- BITZER HOSIERY MFG. CO;** \$10,000; J. (K) Braudes, treas.; Seamless Hosiery; 96 machines; sell direct.
- SMYRNA SHIRT AND HOSIERY CO;** \$15,000; Clarence Prettyman, pres; Edwin Prettyman, treas.; L. Rollin Moore, supt; Shirts of all kinds and Women's and Misses' Ribbed Hosiery; 68 knitting machines; 72 sewing machines; steam; Clarence Prettyman, buyer.
- Stanton.** B.9. B. & O. RR.; P. W. & B. RR.
- KIAMENSI WOOLEN CO.;** \$133,300; (W) Thomas Pilling, pres.; Richard T. Pilling, treas.; Thomas Pilling, agt. and supt; Cassimeres, Cheviots, Blankets, etc.; 5 sets; 40 looms; steam and water; dye and finish; B. Y. Pippet & Co., N. Y., s. agts; Thomas Pilling, buyer. (RR. station, Kiamensi, B. & O. RR.)
- Wilmington.** B.9. B. & O. RR.; P. W. & B. RR.; W. & N. RR.
- BANCROFT JOSEPH, & SONS CO.;** (C, B1 & D) Samuel Bancroft, Jr., pres.; Henry B. Thompson, treas.; John Bancroft, sec. and supt.; Cotton Shade Cambrics, Window Hollands and Shading, Book Cloths and Buckrams; 7,552 ring spindles; 238 looms; steam and water; dye and bleach; Albert D. Smith, N. Y., s. agt. (RR. station, Rockford.)
- BRANDYWINE DYE WORKS;** \$10,000; A. S. (D) Reed, pres.; E. M. Ocheltree, treas.; David Cottrell, supt; Dyeing Cotton Hosiery in Black and Tan; steam; David Cottrell, buyer.
- DELAWARE COTTON CO;** (formerly A-F. (C) lington Mills); A. D. Jones, pres.; S. Baldwin, treas.; W. Dorsey, sec; Melville Gambrell, mgr; Shittings and Dress Ginghams; 14,500 ring spindles; 600 looms; steam; dye; Woodward, Baldwin & Co. s. agts; (buy 26s to 40s yarn.)
- DIAMOND STATE HOSIERY CO;** 15th and (K) Walnut Sts.; \$12,500; W. S. Prickett, pres.; F. E. Gallagher, treas.; Jno. L. Sutphen, sec. and supt.; Men's Cotton Hose, 136 needle, and Cotton, Woolen and Silk Infant's Hosiery; 25 knitting machines; 3 ribbers; 1 sewing machine; finish; sell direct. (Buy 10 to 40 yarns.)
- GEORGETOWN HOSIERY CO;** 13th and (K) Lombard Sts; \$18,000; Jas. W. Ward, pres, buyer and supt; Chas. T. Purnell, treas; Seamless Half Hose, and Children's Ribbed Hosiery; 84 and 136 needle; also Misses' Ribbed Hose; 150 knitting machines; steam; sell direct.
- HAND, JOHN & SONS** (Paterson, N. J.); (S) Thrown Silks and Dress Silks; 4000 spindles; 2 0 looms. (Main mill at Lakeview, N. J.)
- LOVE, HENRY M;** 405 & 407 E. 13th St.; (K) Ribbed Knit Underwear; 66 knitting machines; 75 sewing machines; steam; Critten, Clift & Co., 48 Leonard St, N. Y., s. agts; Henry M. Love, buyer; (buy 8s to 21s best cotton yarns.)
- PLANET MILLS MFG. CO.** (formerly Wilmington Mills Mfg. Co.); Jute Yarns, Twine, Cordage and Ingrain Carpets; 10,000 spindles; 100 looms; steam; dye; sell direct. (*Main office and mill Brooklyn, N. Y., which see.*)
- RELIANCE MILLS MFG. CO.;** \$10,000; John (W) F. Ahrens, pres. and buyer; Wm. Connor, treas.; Herman J. Ahrens, supt.; Men's Worsted Suitings; 36 looms; steam; sell direct.
- TAYLOR CO, CHAS;** \$60,000; Char. (K & D) les Taylor, pres; David McAvoy, treas; George C. Davis, supt; Men's Plain and Fancy Cotton Hose; Ladies' and Misses' Plain and Ribbed Cotton Hose; steam; dye; sell direct. (Buy double roving mule spun, carded peeler from 8 to 26; Combed Egyptian 34 to 60, both two ply and single and mercerized yarn in 22/2 to 34/2.)
- WILMINGTON HOSIERY CO., THE;** \$50,000; (K) A. S. Reed, pres.; E. M. Ocheltree, treas; David Cottrell, supt. and buyer; Ladies' and Misses' Cotton Hosiery; 1-0 knitting machines; steam; dye; Sellers & Steele, Pittsburg and N. Y., s. agts; (buy 9s to 20s yarn.)

## FLORIDA.

No map.

For explanation of abbreviations see page 66.

- Fort White.** (RR name Cow Creek.) (K) F. W. & So. RR.; Plant System.
- THOMPSON, CHAS. II.;** Interested in knitting mill. *Projected.*
- Jacksonville.** Plant system RR; F. C RR; F. E. C. RR.
- JACKSONVILLE KNITTING CO;** \$25,000; (K) J. W. Archibald, pres.; J. B. Lucy, treas.; Ladies' Ribbed Underwear; 25 knitting machines; 50 sewing machines; A. S. Haight & Co, N. Y., s. agts; W. P. Shaver, buyer. (Buy 9s to 24s in all grades.)

**WATSON'S** HEDDLE FRAMES.  
**WIRE HEDDLES.**  
 TEMPERED STEEL WIRE  
 STRIPPER CARDS.

ADDRESS L. S. WATSON MFG. CO., LEICESTER, MASS.. FOR THE VERY BEST MADE

# GEORGIA.

See map on page 68.

For explanation of abbreviations see page 66.

**Alice.** D-9. M. & N. G. RR.

**TATE,** P. M.; Burned 1900. Never re-bui t.

**Aragon,** Polk Co, D-9. S. RR, E. & W. RR.

**ARAGON MILLS** (Branch of the New York **(C)** Mills, New York Mills, N. Y.) D. E. McGaw, agt.; Sheeting, Shirting and Colored Goods; 20,000 ring spindles; 222 broad and 200 narrow looms; steam; dye; A. D. Juillard & Co., s. agts.

**Athens.** D-II. G. RR.; M. & N. RR.; N. RR.; S. A. L. RR.

**ATHENS MFG. Co.;** \$125,000; T. P. Vin- **(C)** cent, pres; William Dootson, supt.; Yarns, from 4s to 12s single, 2 and 3 ply and soft, hard and weaving, Cotton Plaids, and Convict Stripes; 9,600 ring spindles; 320 looms; water; dye; sell direct; T. P. Vincent, buyer.

**COLLETT & INGLE;** \$6,000; Half Hose; 18 **(K)** knitting machines; 3 loopers; 4 ribbers.

**MALLISON BRAIDED CORD CO.;** \$50,000; **(C)** L. F. Edwards, pres, and treas.; W. A. Fowler, supt.; Braided Sash Cord and Back Bands and Webbing; 2000 ring spindles; 7 looms; 150 braiders; water; dye; sell direct and Hooper Sons Mfg. Co. and Surpress, Dunn & Co., N. Y. s. agts; L. F. Edwards, buyer.

**PRINCETON MFG. Co.;** James White, **(C)** pres.; John White Morton, agt.; W. W. Duncan, supt.; Ducks, Osnaburgs and Rope; 4000 ring spindles; 100 looms; water; Putnam, Hooker & Co, Cinn, s. agts; J. White Morton, buyer.

**STANDARD MFG. Co.;** \$22,500; Wm. Doot- **(K)** son, pres; J. H. Dootson, gen'l mgr, and buyer; W. F. Dootson, supt.; Misses', Boys' and Ladies' Ribbed and Men's Half Hose; 160 knitting machines; 25 sewing machines; electric; dye; Lindsay J. Riggins, N. Y. s. agt.

**STAR THREAD MILLS;** James White, **(C)** prop., John White Morton, agt. and buyer. J. C. Bone, supt.; Yarns, 10 to 16s; 6000 ring and 1000 mule spindles; water; Schell, Taylor & Longstreth, Phila. s. agts.

**Atlanta.** E 10. A. & F. RR.; A. & W. RR.; P. RR.; C. of G. RR.; W. S. of S. RR.; G. RR.; S. Ry. Co.; S. A. L. RR.; W. & A. RR.

**ANNETOWN COTTON MILL;** \$50,000; **(C&K)** C. J. Hadan, pres; R. N. Berrien, sec. and treas.; W. B. Underwood, supt.; Duck, Osnaburgs; Yarns and Men's Seamless Hose; 2300 spindles; 76 looms; 15 knitting machines; water; O. D. Loeb, Phila. s. agt. (Office, 303 Equitable Bldg.) Mill at Stone Mountain.

**ATLANTA COTTON MILLS;** \$300,000; R. B. **(C)** Smith (N. Y. City), pres.; E. S. Clark (Rochester, N. Y.), sec.; Sam'l. Stocking, treas.; H. E. Fisher, vice-pres, agt. and buyer; E. B. Fisher, supt.; Drills and Sheetings; 18,000 ring spindles; 550 looms; steam; Treat & Converse, s. agts.

**ATLANTA HOSIERY MILL;** \$25,000 S. A. **(K)** Magill, prop.; Ladies' and Men's Hosiery; 75 knitting machines; steam; dye; sell direct. (Buy white, 8s to 24s and mixed yarns, 8 to 16).

**ATLANTA KNITTING MILLS;** \$25,000; **(K)** Jerome Slacey, pres; C. E. Carrier, sec. and treas.; W. B. Numally, gen'l mgr.; Ladies' Underwear; 15 knitting mach nes; 30 sewing m chines; steam; sell direct.

**ATLANTA RUG MILLS.** *Out of business.*

**ATLANTA WOOLEN MILLS** (Inc. 1896); **(W)** \$150,000; W. M. Nixon, pres; N. O. Mill, agt .

Jeans and Woolen Doeskins; 5000 cotton spindles; 9 sets cards, 60 inch; 240 looms; steam; dye; sell direct.

**BETH MONT KNITTING MILLS;** M. I. **(K)** Stone, sec. and treas.; O. B. Stone, mgr.; Ladies' Cotton Ribbed Underwear; 5 cylinders and 5 sleeveers; S. A. Fallon, N. Y., s. agt.; M. I. Stone, buyer.

**ELIZABETH COTTON MILLS;** \$100,060; **(C)** E. I. Stone, pres; F. W. Stone, treas.; Wm. I. Woodward, supt.; Hosiery Yarns, 6s to 24s; 4896 ring spindles; 168 looms; steam; sell direct; E. I. Stone, buyer.

**EXPOSITION COTTON MILLS;** \$500,000; J. **(C)** D. Turner, pres.; C. D. Fuller, sec. and treas.; G. P. Jeter, supt.; Sheetings and Drilling; 48,000 ring spindles, 163 looms; steam; Joshua L. Baily & Co., s. agts.; J. D. Turner, buyer.

**FULTON BAG & COTTON MILLS;** Box 773; **(C)** \$250,000; Jacob Elsas, pres; C. A. W. Dunk, sec. and treas.; O. Elsas, vice-pres.; H. W. Kimball, supt.; Sheetings, Bags, Baiting, Burlaps, Twines; 45,000 ring spindles; 1500 looms; steam; bleachery; sell direct. (Buy 20 to 28s cotton yarn, single warp on warper beams.) (Also New York, N. Y.)

**GATE CITY COTTON MILLS;** (P. O. **(C)** Address Box 242); \$100,000; Sam'l A. Carter, pres; J. Carroll Payne, vice-pres; Frank Hawkins, treas.; Edward C. Beach, supt.; Extra Curled, Double Rowing Ring Spun Hosiery Yarns; 5,000 spindles; steam; sell direct. (Mill at Magnesia Springs).

**GATE CITY HOSIERY MILLS;** Moved to Denison, Texas, *which see.*

**GEORGIA SCHOOL OF TECHNOLOGY;** **(C&W)** French Textile School; J. W. Bailey, Director; Cotton Machinery for instruction; dyeing.

**GOODWIN, R. L.;** Lace Curtains. *Pro. (C)* *posed.*

**PIEDMONT COTTON MILLS;** B. L. Willing, **(C)** ham, pres; O. D. Woestman, treas.; Baynard Willingham, supt.; 12/2 Yarns (skeins); 2500 spindles. (P. O. address, Egan, near Atlanta; telegraph—Atlanta.)

**SCOTTDALE MILLS;** Geo. W. Scott Invest- **(C)** ment Co., owners; \$500,000; G. W. Scott, pres; G. B. Scott, vi o-pres; C. M. Candler, treas.; L. B. Foster, supt.; Sheetings and Drills; 10,252 ring spindles; 320-40 looms; steam; Woodward, Baldwin & Co., N. Y. s. agts.

**Augusta.** E-13. A. S. RR.; C. R. of G. RR.; P. R. & A. RR.; P. R. & W. C. RR.; S. R. Co. RR.; S. C. & G. RR.

**AUGUSTA FACTORY, THE;** \$600,000; Stew- **(C)** art Phinizy, pres.; A. S. Morris, treas.; Shirting, Sheeting, Drills; 36,096 ring spindles; 1010 looms; water; Woodward, Baldwin & Co., N. Y., s. agts.; Stewart Phinizy, buyer.

**CLEAR WATER BLEACHING & MFG. Co.;** **(B)** \$150,000; Thomas Barrett, Jr, pres, and treas.

**DAVIS COTTON MILLS, THE;** \$200,000; **(C)** (Chas. W. Davis, 2 Leonard Bldg, interest ed); Print Cloths; 10,000 ring spindles; 250 looms; steam. (Mill at Munsey, S. C., Aiken County, 3 1/2 m. north of Augusta.)

**ENTERPRISE MFG. Co.;** \$750,000; Jas. P. **(C)** Verdery, pres, and treas.; O. G. Lynch, supt.; Jas. P. Verdery and O. G. Lynch, buyers; Cotton Sheetings, Shirtings and Drills; 33,000 spindles; 928 looms; water; Woodward, Baldwin & Co., N. Y. and Baltimore, s. agts.

**GLOBE COTTON MILLS** Clark & Co.; (C) A. W. Clark, pres.; J. C. Fargo, treas.; J. C. P. Clark, supt.; Duck, Sheetings Osnabugs, Drills; 3,500 ring spindles; 114 looms; water; sell direct. (Rebuilt plant burned May, 1901.)

**ISAETTA MILL, THE;** Cotton Plaids, Rope (C) and Twine; 4300 spindles; 150 looms; water; dye. (Not in operation.)

**KING MFG. CO., THE JOHN P.;** \$1,000,000; (C) Landon A. Thomas, pres.; Joel Smith, supt.; Cotton Goods; 60,384 spindles; 1812 looms; water; sell direct and Wm. Fisher, Jr. & Co., N. Y., s. agt.; Landon A. Thomas, buyer.

**RIVERSIDE MILLS;** \$150,000; Geo. R. (C) Stearns, pres. and treas.; Wm. A. Reid, sec.; John H. Vivian, supt.; Machinery Waste, Batting, etc.; 90 cards; steam; Putnam, Hooker & Co., Cincinnati; D. F. Stearns, Chicago; Russell Brok Co., St. Joseph and K. City, McCord & Wright, Louisville, Ky., s. agts.

**SIBLEY MFG. CO., THE;** \$900,000; John (C) W. Chafee, pres. and treas.; T. S. Raworth, secy. and buyer; James C. Platt, supt.; Drills, Ducks, Plaids and Checks; 43,200 spindles; 1409 looms; steam; dye; sell direct and Knower, Tarnbull & Co., N. Y., s. agts.

**SUTHERLAND MFG. CO.,** \$35,000; W. T. (C) Davidson, pres.; Edward H. Coats, treas.; J. M. Head, supt. and mgr.; Cotton Yarns; 48 to 308; 4064 ring and 5088 mule spindles; water; sell direct and Schell, Taylor & Longstreth, Eddy & Street, (Prov.) and J. H. Lane & Co., N. Y., s. agts. J. M. Head, buyer.

**WARWICK COTTON MILLS;** \$25,000; Frank (C) R. Clark, pres. and treas.; Sheetings, Shirts and Drills; 4100 spindles; 224 looms; water; Haines & Bishop, s. agts.

**Banning.** E-9. C. of G. RR.

**HUTCHESON MFG. CO.;** \$80,000; C. S. Reid, (C) pres.; J. R. Lassiter, treas.; W. H. Thomas, supt.; Cotton Yarns, 2 to 17s, single and ply; 5000 spindles; water; sell direct. (Telegraph Whitesburg.)

**Barnesville.** F-10. C. of G. RR.

**BARNESVILLE MFG. CO.;** Cotton Mule (C&D) Spun Hosiery Yarns; 10,000 spindles; steam; bleach and dye; sell direct; C. B. Willingham, receiver.

**GEORGIA UNDERWEAR CO.;** \$28,500; (K) A. F. Jones, pres.; A. O. Murphy, treas.; and agt.; Floyd M. Murphy, supt.; Ladies' Cotton Jersey Ribbed Underwear; 25 knitting machines; 30 sewing machines; steam; Bateson & Dowd, 78 Franklin St., N. Y., s. agts. A. O. Murphy, buyer. (Buy 9s, 10s, 11s, 12s & 20s Peeler, Balbriggan & Gray yarn.)

**HANSON-CRAWLEY Co.;** Ladies' Hose, (K) Men's Half Hose and Ladies' and Men's Underwear; 69 knitting machines; steam. (Reorganization in progress.)

**OXFORD KNITTING MILLS;** \$30,000; J. C. (K) Collier, pres.; E. T. Minihuetto, treas.; Ladies' High Grade Ribbed Underwear; 35 knitting machines; 50 sewing machines; steam; bleach; Critten OHL & Co., N. Y., s. agts.; J. C. Collier, buyer.

**Bert.** (Not shown on map.)

**PORTER MFG. Co.** See Cornelia.

**Beverly.** D-12. 3 miles northwest of Mid-dletown, S. A. L.

**PEARL COTTON MILLS;** \$40,000; Thos. M. (C) Swift, pres.; W. A. Swift, treas.; R. A. Fields, supt.; Yarns, Warps and Skeins; Twisted, Cones and Tubes; 7500 spindles; steam and water; W. M. & F. W. Shaples, Chas. J. Webb & Co. and Wm. D'Olier & Co., s. agts. W. A. Swift, buyer.

**Bowman.** D-11. S. Ry. Co.

**WINN, D. J. & Co.;** \$4,000; J. J. Brown, (W) pres.; D. J. Winn, treas. and agt.; N. Bailey, supt.; Seed Cotton and Wool Carding; 1 set; steam; sell direct.

**Canton.** D-9. A. K. & N. RR.

**CANTON COTTON MILLS;** \$100,000; R. T. (C) Jones, pres. and treas.; J. P. Dillard, supt.; 4 yd. Fine Sheetings, 40 in. Sheetings; 4392 ring spindles; 160 looms; steam; Haines & Bishop, N. Y., s. agts.; J. P. Dillard, buyer.

**Carlton.** D-11. Sea Air Line.

**TATE & STOVALL,** interested; Sheetings (C) and Yarns; 5000 spindles; dye. *Proposed.*

**Carrollton.** E-9. C. R. & S. RR.

**MANDEVILLE COTTON MILLS;** \$100,000; L. (C) C. Mandeville, pres.; H. O. Lovvorn, treas.; J. A. Aycock, mgr.; 39 inch 68x72-4 1/2 Cloth and Yarns 26s to 40s from extra carded double roving, either single, 2 or 3 ply; 5,700 ring spindles, 200 looms; steam; Woodward, Baldwin & Co., N. Y.; s. agts. for cloth; Jas. F. White & Co. and Jas. E. Mitchell & Co., for yarns.

**Cedartown.** D-9. C. R. & C. RR.; E. & W. RR.)

**CEDARTOWN COTTON CO.;** (119 So. 4th St., (C) Phila.); \$350,000; Dan'l Baugh, (Phila.) pres.; Charles Adamson, vice pres.; Thomas Adamson, treas.; J. Wright Adamson, agt.; Hosiery and Underwear Yarns; Mill 1, Ring Yarn 10-24; Mill 2, Mule Yarn 8-22; Cones and Cones; 11,162 ring spindles, 12,500 mule spindles; steam; Edward S. Hyde, 223 Chestnut St., Phila., s. agt.; J. Wright Adamson, buyer.

**JOSEPHINE MILLS, THE.;** \$100,000; Daniel (K) Baugh, (Phila.) pres.; J. Wright Adamson, asst. sec. and agt.; Treas. and gen. mgr.; Ladies' Underwear; 2080 cotton spindles; 23 knitting machines; 24 sleeves; steam; Bateson & Dowd, s. agts. (Buy 22s/1, 10/1, 11/1 & 12/1 Peeler on Cones.)

**STANDARD COTTON MILLS;** \$100,000; M. O. (C) Berry, pres.; A. W. Birkeek, sec. and treas.; Wm. Parker, vice-pres. and manager; Extra Carded, Double Roving, Mule Spun Hosiery Yarns; 12,500 spindles; steam. (To increase capacity to 12,500 spindles.)

**WAHNETA MILLS.** (Leased by Josephine (K) Mills and machinery moved.)

**Chattahoochee.** E-9. S. RR.

**WHITTIER MILLS;** \$70,000; N. Whit. (C & D) tier, treas. and gen. mgr.; W. R. B. Whittier, agt. and buyer; H. W. Salmon, supt.; Yarns, Warps, Fire Hose Cord and Specialties; 10,000 ring spindles; steam; dye; N. Whittier, Springfield, Mass., s. agt. Office in Springfield, Mass. *See advertisement.*

**Cochran.** G-11. So. Ry.

**COCHRAN COTTON MILL Co.;** \$75,000; J. J. (C) Taylor, pres.; Morgan Thompson, supt.; D. E. Duggan, supt. and buyer; Ply Warps, 14 to 26; 2,136 ring spindles; steam; sell direct and Wm. D'Olier & Co., Phila., s. agts.

**Columbus.** G-9. C. R. of G. RR.; C. S. RR.; G. M. & G. RR.

**BISS MFG. Co.;** (branch mill); High Class (C) Goods; 20,000 spindles; 600 looms. (*See Macon.*)

**CLEGG MFG. Co., THE;** \$36,000; A. Clegg, (C) pres.; J. F. Clegg, treas. Spreads and Cotton Towels; 118 looms; steam; dye; sell direct. *Idle for several years.*

**COLUMBES MFG. Co.;** \$100,000; F. B. Gordon, pres.; Chas. H. Utley (Boston), treas.; Chas. H. Gordon, supt.; Brown Sheetings; 25,000 spindles; 760 looms; electricity; Wellington, Sears & Co., s. agts.; F. B. Gordon, buyer.

# Whittier Mills,

GENERAL OFFICE, SPRINGFIELD, MASS.

and

MILLS AT CHATTAHOOCHEE, GA.

# Cotton Yarns.

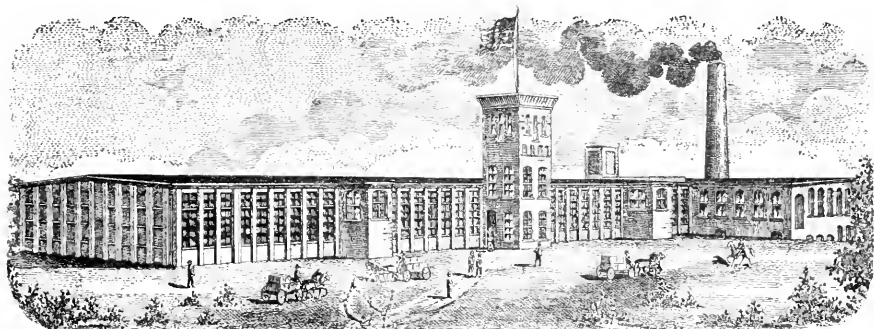

MILLS AT CHATTAHOOCHEE, GA.

. . . , 2<sup>s</sup> TO 40<sup>s</sup> . . . .

Single, or Twisted 2 to 200 ends, Ply, Cable and Hawser  
delivered on Spools, Skeins, Hanks, Creels, Balls,  
Beams, and Warper Balls, Cones.

GRAY OR COLORED.

**SPECIALTIES:**—Soft Banding for Wire Manufacturers,  
Driving Rope, Bandings of all kinds, Macrame and  
Druggist Twines. Tacking and Binding Supplies for  
Converters. Novelties to order.

FIRE HOSE CORD. SASH CORD.

Also DYERS OF COTTON YARNS.

- EAGLE & PHENIX MILLS;** \$750,000 (**C & W G.** Gunby Jordan, pres; E. N. Clemence, treas; W. H. Rankin, supt; Cottonades, Plaids, Outings, Shirtings, Jeans, etc., all Colored; Towels, Cotton Rope and Ball Thread; 51,912 ring spindles; 3,336 mule spindles; 1720 cotton looms; 9 sets woolen cards; 160 woolen looms; water; dye; Fred'k Viotor & Aehelis, N. Y., s. agts; E. N. Clemence, buyer.
- GEORGIA MFG. Co.;** \$100,000; C. L. Perkins, pres.; E. P. Dismukes, Jr., treas.; J. W. Boyd and Chas. E. Doughtie, supts.; 84 needle Hosiery; 96 knitting machines; electricity; sell direct; C. L. Perkins, buyer. (Separate plant for making Pants and Overalls.) (Buy Blue and Black Mixed Yarn, 5 3/4, 6, 7 3/4, 9, 8, 10 single; 102 ply and White, 8 1/4, 30 single.)
- HAMBURGER COTTON MILLS;** \$100,000; (**C** Louis Hamburger, pres.; Geo. S. Hamburger, treas.; Jno. A. Mitchell, gen. mgr; C. W. Hameox, supt; Plaids, Cottonades Denims, Camlets, Tickings and Mitcheline Bed Spreads; 6000 ring spindles; 210 looms; steam; dye and finish; sell direct and E. H. Hamilton & Co., N. Y., s. agts.; Jno A. Mitchell, buyer.
- MUSCOGEE MFG. Co.;** \$157,500; Edward (**C** W. Swift, pres, Jas. P. Kyle, sec. and treas; Plaids, Plaid Shirtings, Denims, Cottonades, Kerseys, Hickory Stripes, Ticking, Chevrots, Towels, Cotton Crashes, Quilts and Yarns; 16,000 spindles; 500 looms; elec. and water; dye; sell direct.
- SWIFT MFG. Co.;** \$200,000; Louis Ham- (**C** burger, pres.; H. L. Williams, sec. and treas.; John T. Abney, supt.; Colored Cotton Cloths and Mitcheline "D" Spreads; 13,075 spindles; 423 looms; steam; dye; sell direct, and E. H. Hamilton & Co., N. Y., s. agt.
- Conyers.** E-10. (Not shown on map.) Ga. RR
- MILSTEAD MFG. Co.;** \$150,000; A. J. Mil- (**C** stead, pres.; F. D. Milstead, sec. and gen'l mgr.; John H. Almand, treas; 10,000 spindles.
- Cordele.** G-10. G. S. & F. RR.; S. A. & M. RR.
- CORDELE COTTON MILLS.** (Machinery removed to Porterdale Mills, Covington, Ga.)
- Cornelia.** D-11. B. R. & A. RR.; S. Ry Co.
- PORTER MFG. Co.;** Jeans, Cassi- (**C & W** mers, Kerseys, Warps, Yarns and Colored Knitting Cotton; 6000 spindles; 4 sets woolen; 80 looms; dye; J. F. White & Co., N. Y. and Phila., s. agts. (Mill at Bert.)
- Covington.** E-10. G. RR.; M. G. & A. RR.
- COVINGTON COTTON MILLS;** \$100,000; T. (**C** C. Swann, pres; W. C. Clark, sec. and treas; O. L. Porter, gen'l. mgr; Sheet- ings; 5,000 spindles; 320 looms; steam.
- PORTERDALE MILLS;** Bibb Mfg. Co., \$2,000,000. (**C** 000; J. F. Hanson, pres.; W. R. White, treas.; O. S. Porter, agt; John A. Porter, supt; Small Ropes, Fish Lines, Seine Twine, Sail Twine, Scwing Twine, etc.; 16,000 ring and 9,000 twisting spindles; water; sell direct; O. S. Porter, buyer. (Buy Yarn, 8s, 10s, 11s, 20s.)
- Dallas.** D-9. So. Ry.
- PAULING COUNTY COTTON MFG. Co.;** (**C** \$100,000; E. Davis, pres; R. G. Gunn, sec. and treas; C. L. Strolls, supt; Hosiery Yarns; 3,100 spindles; steam; Wm. D'Olier & Co., Phila., s. agts.
- Dalton.** C-9. W. S. of S. RR.; W. & H. RR.
- CROWN COTTON MILLS;** \$300,000; Geo. W. (**C** Hamilton, pres.; F. T. Hardwick, treas.; J. W. Brown, supt.; Duck and Osnaburgs; 20,000 ring spindles; 541 looms; steam; J. H. Lane & Co., N. Y., Boston, Chicago and Phila., and Putnam, Hooker & Co., Cincinnati, s. agts.; G. W. Hamilton, buyer.
- Debruce.** E-12. A. S. RR.
- PHOENIX FACTORY;** M. B. Hatcher, pres; (**C** W. B. Young, treas; W. W. Hack, supt; Yarns; 8s to 20s; 5100 spindles; steam and water; sell direct.
- Dennard.** G-10. (RR. station, Perry or Kathleen.) G. S. & F. RR.
- HOUSTON FACTORY;** Dennard & Hughes, (**C** (successors to Dennard & Moore.) Sheet- ings; 2240 spindles; 600 looms; water; sell direct. *Not running.*
- Douglasville.** E 9. S. RR.
- NEW CENTURY COTTON MILLS** (formerly (**C** Georgia Western Cotton Mills); J. A. James, pres; R. M. Wilson, sec; Sam'l. Hale, supt; Sheetings, Ducks and Drills; 20,000 spindles; 500 looms; steam.
- Dublin.** F-11. M. D. & S. RR.
- DUBLIN COTTON MILLS;** \$125,000; Wm. (**C** Pritchett, pres; J. M. Finn, treas; J. Wheeler, Mears, supt; 4 yd. Sheetings; 5,000 spindles; 160 looms; steam.
- Eastman.** G-11. So. Ry.
- EASTMAN COTTON MILL Co.;** \$100,000; (**C** M. H. Edwards, pres; Sol. Herman, vice-pres; C. H. Peacock, sec and treas; Sheet- ings, Shirtings, Yarns; 3,000 spindles; 100 looms. (Expect to add 7000 additional spindles and 260 looms in 1902.)
- Eatonton.** E-11. C. of Ga. R. R.
- EATONTON ELECTRIC Co.;** \$75,000; J. W. (**C** Preston, pres; E. M. Brown, treas; Un- bleached Sheetings and Shirting; 2,500 spindles; 100 looms; steam and elec- tricity; Haines & Bishop, N. Y. s. agts.
- MIDDLE GEORGIA COTTON MILLS;** (**C** \$60,000; B. W. Hunt, pres; T. G. Greene, vice-pres; E. B. Ezell, sec. and treas; J. A. Asbell, supt.; Cotton Yarns; 3328 ring spindles; steam; sell direct; B. W. Hunt, buyer.
- QUINETTE MFG. Co.;** \$50,000; R. A. Reid, (**C** pres; E. M. Brown, treas; Yarns; 3,000 ring spindles; steam; Haines & Bishop, N. Y. s. agts.
- Elberton.** D-12. S. Ry. Co.; S. A. L. RR.
- SWIFT'S COTTON MILL;** \$100,000; Thos. M. (**C** Swift, pres; Isaac G. Swift, treas; R. A. Field, supt; 40 inch sheetings; Ply Yarns and Rope; 7500 ring and 2000 twisted spindles; 174 looms; steam; dye; sell direct; T. M. Swift, buyer.
- Fitzgerald.** H-11. G. & A. RR.
- IRWIN COUNTY COTTON MILLS;** \$150,000; (**C** Wright Garbett, pres; R. V. Bowen, vice- pres; W. R. Bowen, sec. and treas; Yarns; 5,000 mule spindles.
- Forsyth.** F-10. C. of G. RR.
- FORSYTH MFG. Co.;** \$50,000; J. M. Ponder, (**C** pres.; C. A. Ensign, treas.; C. J. Kennett, supt.; J. M. Ponder, buyer; Warps, Single and Twisted, and Hosiery Yarns in white; 6,000 spindles; steam; sell direct.
- TRIO MFG. Co.;** \$50,000; R. P. Brooks, (**C** pres; J. W. Newton, treas; J. M. Frazier, supt.; Cotton yarns in skeins, Cones and Tubes, single or plys, 6s to 20s; 3,000 ring spindles; steam; sell direct; R. P. Brooks, buyer.
- URSON MFG. Co.** See Waymanville, Ga.
- Fort Valley.** F-10. C. of Ga. RR. So. Ry.
- FORT VALLEY KNITTING MILLS;** F. O. (**K** Miller, pres.; J. M. Jones, sec. and treas. and gen'l. mgr.; Ladies' and Boys' Cotton Ribbed and Fleece Underwear; 10 knitting machines; steam; dye; sell direct.
- Gainesville.** D-10. G. RR.; S. Ry. Co.
- GEORGIA MFG. Co.;** \$50,000; Dr. Robt. E. (**C** Greene, treas; Yarns, Chain, Beam and Ball Warps; 3300 ring spindles; steam; Buckingham, Paulson, & Co., N. Y., s. agts.



**GAINESVILLE COTTON MILLS;** \$500,000; (C) John H. Montgomery, pres.; L. G. Potter, treas.; J. C. Lewis, supt.; Broad Sheetings; 25,200 ring spindles; 740 looms; Deering, Milliken & Co. s. agts. (Machinery from Vesta Cotton Mills, Charleston, S. C. removed here.)

**PACOLET MFG. Co;** Standard Sheetings (C) and Drills; 50,000 ring spindles; 2,400 looms. (Also Pacolet, S. C.)

**Grantville.** E.9. A. & W. P. RR.

**GRANTVILLE HOSIERY MILLS** (incor. (K 1896); \$25,000; N. O. Banks, pres.; Glenn Arnold, treas.; J. F. Brasch, supt.; 84 needle Hose and Half Hose; 75 knitting machines; steam; sell direct and Joseph Colter, s. agt.; N. O. Banks, buyer. (Buy 6 to 20s yarn, mixed.)

**Greensboro.** E-12. G. A. R. RR.

**MARY LEILA COTTON MILL;** \$100,000; E. (C) A. Copeland, pres.; C. E. Monfort, sec. and treas.; W. R. Jackson, vice-pres.; S. T. Buchanan, supt.; Plain Sheetings, 4 yd. goods; 5,000 ring spindles; 160 looms; steam; James E. Reynolds & Co. s. agts.

**Griffin.** E.10. C. of G. RR.; G. M. & G. RR. **BOYD & MANGHAM.** Interested in another (C) \$125,000 cotton mill. Douglass Boyd, probably manager. *Proposed.*

**GRIFFIN KNITTING MILLS;** \$20,000; (K) J. J. Mangham, pres.; Douglas Boyd, treas.; W. H. Brayton, supt.; Men's Perfect Fitting Elastic Ribbed Underwear; 12 knitting machines; steam; sell direct; W. H. Brayton, buyer. (Buy 7s and 18s carded and combed Peclers, solid colors and Egyptian, natural.)

**GRIFFIN MFG. Co.;** \$360,000; W. J. Kincaid, pres.; J. M. Brawner, treas.; C. Wheeler, supt.; Plaids, Chevots, Ticking, Cottonades, Fancy Ducks; Donnets; Covert Cloth; Hickory Stripes; 16,000 ring spindles; 600 looms; steam; dye; A. D. Smith, N. Y. s. agt.; officers and supt., buyers.

**KINCAID MFG. Co.;** W. J. Kincaid, (C) pres.; Jas. M. Brawner, treas.; A. G. Martin, supt.; Supt. and Officers of Co., buyers; Ticking, Towels, Crashes, Damasks, etc.; 12,500 ring spindles; 472 looms; steam; dye; Whitman & Phelps, N. Y., s. agts.

**RUSHTON COTTON MILLS;** \$125,000; B. R. (C) Blakely, pres.; J. P. Nichols, sec. and treas.; Sheetings, Drills, White Napped Goods; 10,000 spindles; 320 looms; steam; Clark & Campion, s. agts.

**SPALDING COTTON MILLS, THE;** \$125,000; (C) W. J. Kincaid, pres.; J. J. Mangham, treas.; Allan Little, supt.; Montic Cloth, Jeans, Fancy Weaves, Cotton Diaper, etc.; 9,000 ring spindles; 300 looms; steam; sell direct and Albert D. Smith, N. Y. s. agt.; W. J. Kincaid and J. J. Mangham, buyers.

**Hampton.** E.10. C. of G. A. R.

**HAMPTON COTTON MILLS;** \$50,000; A. J. (C) Henderson, pres.; W. M. Harris, sec. and treas.; J. B. West, supt.; Hosiery and Underwear Yarns, up to 24s on Cones; 3,000 ring spindles; steam; sell direct.

**HENDERSON MFG. Co;** A. J. Henderson, (K) pres.; A. M. Henderson, sec. and treas.; A. D. Henderson, mgr.; Ladies' Cotton Ribbed Underwear; 12 knitting machines; 6 sleeves; 24 sewing and finishing machines; steam; Sutton & Co. and J. L. Stern, N. Y. s. agts.; A. J. Henderson, buyer. (Buy 8s to 12s Peeler and Egyptian on cones.)

**Harmony Grove.** D-11. Northeastern RR.

**HARMONY GROVE MILLS;** \$200,000; Dr. L. G. (C) Hoodman, pres.; W. B. Hoodman, treas.; W. E. Green, supt.; Brown Sheetings and

Drills; 10,000 spindles; 336 looms; steam; Robinson & Shackleton, N. Y., s. agts.; Dr. L. G. Hoodman, buyer.

**Hartwell.** D-11. Hartwell RR.

**WITHAM COTTON MILLS, THE;** \$85,000 (C) Asa G. Candler, pres.; Asa G. Candler, Jr., sec. and treas.; Harold M. Griffin, gen'l. mgr.; Single and Ply Yarns, 12s to 60s, Skeins, Drills, Denims and Sheetings; 6,032 spindles; 102 looms; steam; dye; Joshua L. Bailly & Co., s. agts; H. M. Griffin, buyer.

**Hawkinsville.** G-11. So. RR.; O. & W. RR.

**HAWKINSVILLE COTTON MILLS;** W. N. (C) Parsons, pres.; McC. Pate, sec. and treas.; W. H. Murry, supt.; 4 yd. Sheetings; 3000 ring spindles; 80 looms; steam; sell direct.

**High Shoals.** E-11. Macon & Northern RR.

**HIGH SHOALS MFG. Co.;** \$120,000; John (C) W. Hinton, pres.; J. W. Rodwell, sec. and treas.; A. J. Baxter, supt.; Yarns, Plaids, Shirtings, Checks, Stripes, etc.; 10,000 spindles; 81 looms; steam and water; dye; Putnam, Hooker & Co., W. M. & F. W. Sharples, s. agts. (RR. station and freight address, Bishop.)

**Hogansville.** F-9. A. & W. P. RR.

**HOGANVILLE MFG. Co;** \$100,000; J. E. (C) Dunson, pres.; Judson Mobley, treas.; Geo. W. Murphy, supt.; Heavy Duck and Yarns; 5,200 ring spindles; 54 looms; steam; sell yarns direct; J. Spencer Turner Co., ducks.

**Jackson.** E-10. Southern RR.

**PEPPERTON COTTON MILLS;** \$200,000; J. R. (C) Wright, pres.; F. S. Etheridge, sec.; A. H. Smith, treas.; A. L. Asbell, supt.; 4-yd. Brown Sheetings and Hosiery Yarns, 20s to 24s; 12,900 spindles; 16 sets cards; 360 looms; steam; J. L. Bailly & Co. s. agts.

**Jefferson.** D-11. Ga. RR.

**JEFFERSON COTTON MILLS;** \$75,000; H. (C) W. Bell, pres.; Frank Roberts, treas.; J. C. Turner, agt.; M. R. Chrystal, supt.; 4yd. Brown Sheetings; 3000 ring spindles; 150 looms; steam; Hunter Mfg. & Com. Co., s. agts.; J. C. Turner, buyer.

**Jewell's.** E-12. G. RR.

**BOWEN, JEWELL & Co.;** Jewell Cot. (C) ton Mills; Geo. Bradley, supt.; Bag Goods and Flour and Meal Bags; 4000 ring spindles; 121 looms; steam and water; sell direct; D. A. Jewell, buyer. (Buy single yarns, 8 and 10, also 3 and 4 ply 12s.) (RR station, Mayfield, 4 1-2 miles.)

**Juliette.** F-10. S. RR.

**GLOVER MFG. Co;** \$70,000; J. W. Birch, (C) pres.; W. P. Glover, treas.; D. E. Duggan, supt.; Coarse Yarns; 2040 ring spindles; water; sell direct; W. P. Glover, buyer.

**Lafayette.** C-8. C. R. & C. R.

**ELIZABETH HOSIERY MILLS;** \$26,000 (to (K) be increased to \$35,000); A. R. Steele, pres.; W. H. Steele, treas.; H. C. Alexander, supt.; Ladies' Seamless, Fast Black Hosiery; 40 knitting machines; steam; dye; sell direct; W. H. Steele, buyer.

**UNION COTTON MILLS;** \$100,000; A. R. (C) Steele, pres.; P. D. Fortune, treas.; R. S. Steele, supt.; Four yard Sheetings, Rowling and Drills; 7680 ring spindles; 212 looms; steam; Putnam, Hooker & Co., Cincinnati, and Whitman & Phelps, N. Y., s. agts.; R. S. Steele, buyer. (Buy yarns 16/1 for toweling.)

**La Grange.** F-9. A. & W. P. RR.; G. S. & B. RR.

**DIXIE COTTON MILLS;** \$450,000; O. A. Dun (C) son, pres. and mgr.; J. H. Edmondson, treas.; J. J. E. Dunson, sec.; Drills, Sheet- ing, Osnaburg, and Hosiery Yarns; 20,000

- ring and 1480 mule spindles; 400 looms; steam; sell direct and Converse, Stanton & Co., J. Spencer Turner Co., N. Y., s. agts.; W. S. Dunson, buyer.
- LA GRANGE MILLS;** \$157,400; J. M. Bar- (C) nard, pres.; L. J. Render, treas.; G. W. Carpenter, supt.; J. M. Barnard, buyer; Yarn and Duck; 10,000 ring spindles; 124 looms; steam; J. H. Lane & Co., Boston and New York, s. agts.
- PARK MILLS** (formerly Troup Factory;) (C) L. M. Park & Sons; E. Lung, gen'l mgr.; Three-yard Sheetings, 4x4 Shirtings, Drills, Duck and Yarns; 1600 spindles; 52 looms; steam and water; sell direct and James Freeman Brown Co., N. Y., s. agts. (RR. station, 10 miles S.E. of La Grange).
- UNITY COTTON MILLS;** \$300,000; C. V. (C) Truitt, pres.; F. E. Callaway, treas.; Geo. W. Murphy, supt.; Heavy Duck and Yarns; 10,500 ring spindles; 150 looms; steam; J. H. Lane & Co., s. agts.; C. V. Truitt, buyer.
- Lavonia.** D-11. So. Ry.
- LAVONIA COTTON MILLS;** \$45,000; M. (C) Crawford, pres. and treas.; J. H. Burton, agt.; J. D. Lewis, supt.; Yarns, 20s in 2, 3, 4 and 5 ply; 2,500 ring spindles; steam; Wm. D'Ollier & Co. and Buckingham, Paulson & Co., s. agts.; M. Crawford, buyer.
- Lawrenceville.** D-10. Sea Air Line.
- LAWRENCEVILLE MFG Co.** (formerly (C) Gwinnett Cotton Mills); Yarns, 8s to 26s, for Knit Goods; 4,500 mule spindles; steam.
- Lindale.** FLOYD Co. D-9. 412 miles south of Rome. S. RR.
- MASSACHUSETTS MILLS IN GEORGIA;** \$1, (C) 000,000; Charles L. Lovering, treas.; H. P. Meikleham, agt.; Wm. Audley Marshall, supt.; Duck, Drill and Coarse Sheetings; 51,264 ring spindles; 1774 looms; steam; Smith, Hogg & Gardner, N. Y., s. agts. (See also Lowell, Mass.)
- Macon.** F-11. C. of G. RR.; W. S. of S. RR.; G. S. & F. G. RR.; M. & N. RR.; M. D. & S. RR.
- BIBB MFG. Co.;** \$1,800,000; J. F. Hanson. (C) pres.; W. R. White, treas.; Yarns, Twine, Cordage and Hosiery; 25,000 spindles; steam; dye; sell direct; salesroom, 20 Thomas St., N. Y. (Also Columbus.)
- EXCHANGE COTTON MFG. Co.** \$25,000; (K) J. W. Cabaniss, pres.; George L. Snowden, treas.; Men's Ribbed Underwear; 12 knitting machines; steam; James Talcott, s. agt.
- MACON KNITTING Co.;** \$300,000; J. F. (K) Hanson, pres.; W. R. White, treas.; Joseph Bannor, supt.; Coarse and Medium Hosiery and Infants' Underwear; 367 knitting machines; steam; dye; sell direct; Joseph Bannor, buyer.
- MANCHESTER MFG. Co.;** \$100,000; W. A. (C) Crutchfield, pres.; J. W. Cabaniss, treas.; J. D. Hough, mgr.; Cotton Yarns, 2s to 30s, single and plys, Hosiery Yarns, Carpet Warp, Cones, Tubes, Balls, Skeins; 10,000 ring spindles; steam; dye and finish; sell direct and through agts.; J. D. Hough, buyer.
- PAYNE COTTON MILLS;** \$69,500; W. S. (C) Payne, pres.; W. S. Payne, Jr., sec. and treas.; J. H. Kane, supt.; Yarns from 8s to 12s; 5000 ring spindles; steam; sell direct and through agts.; W. S. Payne, buyer.
- SCHOFIELD MFG. Co.;** \$40,000; F. O. Scho- (K) field, pres.; J. S. Budd, treas.; W. P. McQuillan, supt.; Ribbed Cotton Underwear; 33 knitting machines; 50 sewing machines; steam; dye; Critten, Clift & Co., s. agts.; pres., treas. and supt. buyers. (Buy 6-7-8 and 20s, mostly 7 and 8 yarns.)
- WILLINGHAM COTTON MILLS;** \$150,000; (C) C. B. Willingham, pres.; B. E. Willingham, treas.; G. T. Kinnett, supt.; Cotton Duck and Yarns, 6 to 14, single and ply; 12,000 ring spindles; 120 looms; steam; sell direct; B. E. Willingham, buyer.
- Marietta.** D-9. W. & A., A. K. & N. RR.
- MARIETTA KNITTING Co.;** \$100,000; R. H. (K) Northcutt, pres. and treas.; John H. Barnes supt.; Seamless Half Hose; 116 knitting machines; steam; dye; sell direct; R. H. Northcutt, buyer.
- Middleton.** D-12. S. A. Line.
- BANNOCKBURN COTTON MILLS;** \$80,000; (C) Col. Geo. C. Grogan, Cuyler Smith (Atlanta) and Y. H. Bromley (Phila.) interested. Cottonades; 7200 spindles; 250 looms. Proposed.
- Millen.** F-13. C. of Ga, M. & S. W. RR.
- MILLEN COTTON MILL;** \$75,000; J. H. (C) Daniel, pres.; C. H. Humphrey, treas.; S. W. Palmer, sec.; 26 to 40 yarns; 5,376 ring spindles; steam; J. B. Tiedeman, N. Y., s. agt.; John R. L. Smith, receiver. (In litigation.)
- Milner.** F-10. C. of Ga. RR.
- IVERSON STERNE MFG. Co.** Back Bands. (C)
- Monroe.** E-10. Ga. RR
- MONROE COTTON MILLS;** \$150,000; B. S. (C) Walker, pres.; A. B. Mobley, sec.; J. W. Mears, supt.; 3 and 4 yd. Brown Sheetings; 9200 spindles; 500 looms; steam; Haines & Bishop, N. Y., s. agts.
- WALTON COTTON MILL Co.;** \$100,000; C. (C) T. Mobley, pres.; Edgar S. Tichenor, sec. and treas.; O. H. Farr, supt.; 3 yd. Drills and Brown Sheetings; 5,000 ring spindles; 156 looms; steam; Haines & Bishop, N. Y., s. agts.
- Moultrie.** H-10. Ga. No. RR.
- MOULTRIE COTTON MILLS;** \$100,000; W. (C) C. Vereen, pres.; Z. H. Clark, sec. and treas.; John Schofield, supt.; 4 yd. Sheet- ing and Drills; 5,000 spindles; 160 looms; Haines & Bishop, N. Y., s. agts.
- Newnan.** E-9. A. & W. P. RR.; C. of G. RR.
- NEWNAN COTTON MILLS;** \$300,000; R. D. (C) Cole, Sr., pres.; J. F. Lovejoy, treas.; P. R. Murphy, agt. and gen'l mgr.; R. A. Field, supt.; White and Colored Hosiery Yarns, Warps, Ball Sewing Thread, Wrapping and Seine Twines; 17,500 ring spindles; steam; dye; Hooper Sons Mfg. Co., Phila., s. agts.
- Nicojack.** E-9. W. S. of S. RR.; S. Ry. Co.
- CONCORD WOOLEN MILL;** Rice & Love, (W) props.; 3/4 Cassimeres; 1 set; 32 looms; water and steam; dye; sell direct; J. W. Rice, buyer. (Buy 4s, 10s, 12s, single, chain warps and fancy worsted yarns, 20 cut on cones.)
- Palmetto.** E-9. A. & W. P. RR.
- PALMETTO COTTON MILLS;** \$50,850; J. K. (C) P. Carlton, pres.; F. R. Smith, treas.; H. L. Johnston, vice-pres. and gen'l mgr.; W. S. Harbin, supt.; Cotton Duck, and Skein Yarns; 5000 ring spindles; 87 looms; steam; Robinson, Hughes Co., Louisville, s. agts.; H. L. Johnston, buyer.
- Pelham.** H-10. Plant System.
- PELHAM MFG. Co.;** \$125,000; J. L. Hand, (C) pres.; B. U. Curry, treas.; S. B. Shipp, supt.; Ducks, Osnaburgs and Heavy Drills; 4380 ring spindles; 138 looms; steam; sell direct; J. L. Hand, buyer.
- Penfield.** E-11. RR. station, Woodville, Ga. RR.
- PENFIELD HOSEIERY MILLS;** E. R. Bos. (K) well, pres.; W. B. Boswell, treas.; T. W. Woodham, supt.; Half Hose, 176 & 136 needle; 24 knitting machines; steam; sell direct; W. B. Boswell, buyer. (Buy H and H white hosiery yarn.)
- Pottersville.** G-10. 3 m. from Reynolds on C. of G. RR.

**TAYLOR MFG. Co.**; (Bibb Mfg. Co. Macon, (C Ga.) W. R. Rodgers, supt.; Carpet Warp and Hosiery Yarns; 2,000 spindles; steam and water; sell direct.

**Quitman.** J.H. Plant System.

**ATLANTIC & GULF MILLS**; \$100,000; F. J. (C Spain, pres.; W. W. Walker, vice-pres.; H. W. Stubbs, sec. and treas.; J. W. Spain, agt.; G. W. Brown, supt.; Cotton Hosiery Yarns; 5,000 spindles; steam; Catlin & Co., Boston and N. Y., s. agts.; H. W. Stubbs, buyer cotton; J. W. Spain, supplies.

**Raccoon Mills.** D.S. C. R. & C. RR.

**RACCOON MFG. Co.**; \$164,700; Jno. S. Cleg. (C horn, pres.; J. M. Wyatt, treas.; R. S. White, supt.; J. M. Wyatt, buyer; Sheetings, Shirtings and Drills; 3400 spindles; 104 looms; sell direct.

**Home.** D.9 C. R. & C. RR.; W. S. of S. RR.; R. RR.

**ANCHOR DUCK MILLS**; \$35,000; C. A. (C Hight, pres.; C. E. McLin, treas., agt., supt. and buyer; Wide Duck; 42 looms; steam; Putnam, Hooker & Co. and T. A. Shaw & Co., s. agts.

**ROME COTTON FACTORY**; \$100,000; Henry (C Harvey, pres. and treas.; F. A. Hamilton supt.; Cotton Duck; 5136 ring spindles; 112 looms; steam; sell direct and R. McK. Jones & Co., St. Louis, J. H. Lane & Co., N. Y., T. A. Shaw & Co., (Chicago, s. agts.; J. Harvey, buyer. (Sometimes buy 1/3 and 3/4 yarns.)

**Rossville.** C.S. 2 1-2 miles from Chat-  
ta-nooga, Tenn.) C. R. & C. RR.

**PARK WOOLEN MILLS**; \$100,000; W. P. (W Wilson, pres.; J. L. Hutcheson, treas.; C. A. Taylor, supt.; Jeans and Union Cassi-  
meres; 4 sets; 110 looms; steam; dye; sell direct; C. A. Taylor, buyer. (Buy cotton yarns on beams from 8 to 30, single and double, colors.)

**RICHMOND HOSEIERY MILLS**; \$200,000; (K E. G. Richmond, pres.; R. W. Barr, vice-pres.; Jno. A. Boyle, treas.; Garnett Andrews, Jr., gen'l mgr; Mill No. 1; W. H. Shepherd, supt.; All Grades of Mens', Misses' and Boy's Seamless Hosiery; 500-knit-  
ting machines; steam; dye; sell direct; N. Y. Office 309 Church St.; Garnett Andrews, Jr, buyer; (buy from 7/1 to 24 1 carded Peeler and 10/1 to 36/2 and 60/1 Egyptian yarn.) (Also see Chattanooga, Tenn., for Mills 2, and 3.)

**SOUTHERN SHODDY MILLS**; G. A. Rin. (W Ker, mgr; R. B. Rinke, sec; Shoddies; 1 set; 2 pickers; steam; dye; sell direct

**Roswell.** D-10. S. Ry. Co.

**LAUREL MILLS MFG. Co.**; \$55,500; S. Crow. (W ley, pres.; J. O. Crowley, treas.; Geo. E. Crowley, supt.; S. Crowley, buyer; Cas-  
simeres, and Jeans, 4 sets; 67 looms; water; dye; sell direct.

**ROSWELL MFG. Co.**; \$262,000; S. Y. (C Stribling, pres. and treas.; President, buy-  
er; Sheetings, Shirtings, Single and Plie'd Yarns and Warps; 12,600 ring spindles; 120 narrow and 48 broad looms; steam and water; sell direct and Jas. H. White & Co., N. Y. and Phila., and Cooley, Turn-  
bull & Co, N. Y., s. agts.

**Sargent.** E-9. C. of G. RR.

**WAHO MFG. Co.**; \$48,000; H. C. Amall. (C pres.; T. G. Farmer, treas.; J. A. Smith, supt.; Yarns and Rope; 3000 spindles; steam and water; Putnam, Hooker & Co., Cincin., O., O. D. Loeb, Phila., s. agts.)

**Savannah.** G.H. C. of G. RR.; F. C. & P., RR.; P. S. RR.

**SAVANNAH COTTON MILLS**; G. H. Tilton, (C Tilton, N. H. prop; A. E. Gillman, supt.; Colored Hosiery and Underwear Yarns; 7736 mule and 2632 ring spindles; steam; dye.

**Shoal Creek.** D.H. S. Ry. Co.

**SHOAL CREEK MFG. Co.**; Cotton Yarns (C and Ball Thread; 2,280 spindles; water; Buekingham, Paulson & Co., Phila., Chi-  
cago and N. Y., s. agts. (RR. station, La-  
vonia, 6 miles.)

**Social Circle.** E-10. Ga. RR.

**SOCIAL CIRCLE COTTON MILLS**; \$100,000, (C J. B. Robinson, pres; J. L. Newton, sec. and treas; Fancy Cottons; 5,000 spindles; 160 looms; steam.

**Sparta.** E.H. E. & W. Ga. RR.; Ga. RR.

**SPARTA COTTON MILLS**; D. P. Ferguson, (C 5,200 spindles. (Not running.) For Sale.

**Stone Mountain.** E-10. G. RR.

**ANNESTOWN COTTON MILL.** See Atlanta. (C

**Tallapoosa.** E-9. Sou. Ry.

**KIMBALL, W. C. & Co.**; W. C. Kimball, (K supt.; Misses' and Childrens' Ribbed Hose; 8 knitting machines; 16 cylinders; steam; W. H. Kimball, buyer.

**TALLAPOOSA COTTON MILL Co.**; \$125,000; (C J. C. Tumbin, temp. pres.; M. V. Sewell, temp. vice-pres.; A. V. Howe, sec. Pro-  
posed.

**Tennille.** F-12. C. of Ga. RR, S.C. & Ga. RR.

**TENNILLE COTTON MILLS**; \$70,000; J. W. (C Smith, pres.; I. Boshinski, treas.; Yarn; 4000 spindles; steam; Wm. D'Olier & Co., Phila., s. agts.

**Thomaston.** F-10. C. of Ga. RR.; Macon & Bir. RR.

**THOMASTON COTTON MILLS**; \$100,000; R. (C E. Hightower, pres.; John T. Alden, sec. and treas.; A. T. Mathews, supt.; Sheet-  
ings, Drills; 7,000 ring spindles; 164 looms; steam; J. E. Reynolds & Co., N. Y., s. agt.; Albert T. Mathews, buyer.

**Thomson.** E-12. Ga. RR.

**SMITH, J. E.**; COTTON MFG. Co; \$50,000; (C Jno. E. Smith, pres; J. T. Neal, treas.; C. R. Day, supt; 208 Single Yarn; 3,112 s. agt.; steam; R. A. Blythe, Phila., s. agt.

**Tifton.** H-11. Ga. Sou. & Fla. RR; Plant System.

**TIFTON COTTON MILLS Co**; \$100,000; H. H. (C Tift, pres; Thos. B. Puckett, treas; T. A. Shipp, supt.; Fine Yarns; 5,152 ring spin-  
dles; steam; Wm. D'Olier & Co., Phila., s. agts; Supt. and Treas., buyers.

**TIFTON KNITTING MILLS**; \$10,000; H. (K Kent, pres.; Thos. B. Puckett, treas.; W. W. Humley, supt.; Ladies Hose; 50 knit-  
ting machines; steam; dye; sell direct; treas., buyer; (buy 14s and 24s Cones.)

**Toccoa.** C-11. S. RR.

**CAPPS COTTON MILL**; \$60,000; T. A. Capps, (C pres. and treas; Hosiery Yarns, 18s to 24s; 2,080 ring spindles; steam; Chas. J. Webb & Co., s. agts; T. A. Capps, buyer.

**Toccoa COTTON MILLS, THE**; \$61,000; (C Dr. Jeff Davis, pres; W. R. Bruce, treas; J. W. Goodroe, supt; Fine Sheetings and Hosiery Yarns on Cones; 2 cone wind-  
ling machines; 8,000 ring spindles; 216 looms; steam; Robinson & Shackleton, N. Y., and Wm. D'Olier & Co., Phila., s. agts.; E. E. Mitchell, sec, and J. W. Good-  
roe, buyer.

**Trion Factory.** D.S. C. R. & C. RR.

**TRION MFG. Co.**; \$600,000; A. S. Hamilton, (C pres. and treas.; G. R. Myers, sec.; J. L. Blair, supt.; Treasurer and Superintend-  
ent, buyers; Shirtings, Sheetings, Drills and Rope; 50,016 ring spindles; 1122 looms; steam and water; Treat & Converse, N. Y., Robert McK. Jones & Co., St. Louis, s. agts. (RR. station, Trion.)

**Union Point.** E.H. G. RR

**UNION MFG. Co.**; \$58,000; Harold (C&K Lamb, pres., treas., and supt.; Mule

- Yarns, 10s to 24s and High Grade Hosiery and Underwear; 2400 spindles; 10 underwear and 42 hosiery knitting machines; steam; dye and bleach; sell direct. (Bleachery, 1,600 lbs per day.)
- Valdosta.** J-I1. A. V. & W. RR; Plant System.
- STRICKLAND COTTON MILLS; \$175,000; (C) B. F. Strickland, pres.; E. W. Lane, sec. and treas.; 3 and 4 yd. Sheetings and Drills; 10,000 ring spindles; 325 looms; steam; sell direct and through agents.
- VALDOSTA COTTON MFG. & SUPPLY CO. (C) \$75,000; Cotton, Yarn and Ball Thread; 5000 spindles; J. N. Griffin, interested. (Charter secured; not yet built.)
- Waleska.** D-9. A. K. & N. RR.
- FISCHER, E. A.; R. M. Wilson, supt; Col. (C) Tom Thread Rope; 800 ring spindles; water; sell direct. (RR. station, Canton.)
- Warrenton.** E-12. Ga. RR,
- BATTLE, B. L. MFG. Co.; \$25,000; J. F. (K) Allen pres; W. F. Wilhoit, sec. and treas.; Men's and Ladies' Underwear; 20 knitting machines; steam; finish. *Burned January, 1902. Probably rebuilt.*
- Washington.** E-12. Ga. RR.
- ALMAND, R. A. Plant sold and removed to Alexander City, Ala.
- Waycross.** H-12. Plant Sys.
- WAYCROSS KNITTING MILL; \$30,000; (K) Geo. R. Youmans, pres.; J. S. Bailey, treas.; Geo. T. Woodin, Jr., gen'l mgr; Jersey Ribbed Underwear; 40 knitting machines; steam; sell direct.
- Waymanville.** F-10. C. R. of G.; G. S. & F. RR.
- URSON MFG. Co.; (formerly Wayman (C) Cotton Mills); 44 Sheetings, 34 Shirts, Drillings, Yarns, Ball Thread, Batts, Cone and Tube; 3408 spindles; 30 sets; 76 looms; steam and water; sell direct. (Office at Forsyth.) (RR. station, The Rock.)
- West Point.** E-9. A. & W. P. RR.
- GALETON COTTON MILLS; (Riverdale Cot. (C) ton Mills); \$100,000. See Riverview, Ala.
- LANETT BLEACHERY & DYE (BI & D) WORKS; \$60,000; W. H. Wellington, pres.;
- Justin E. Gale, treas; L. Lanier, vice-pres; P. J. McNamara, ingr. and supt; dye and bleach; Cotton Goods; steam; Wellington Sears & Co, Boston, s. agts. (Bleaching capacity, 5 tons per day; dye, 150,000 yds. per day).
- LANETT COTTON MILLS; \$1,000,000; L. (C) Lanier, pres.; F. B. Sears, treas.; Scott Maxwell, supt.; Drills, Sateens, Fancy Ducks and Sheetings; 61,000 ring spindles; 1500 looms; steam; Wellington, Sears & Co., Boston, s. agts; L. Lanier, buyer.
- LANGLEY MFG. Co., THE; \$100,000; E. (C) Lang, pres. and gen'l mgr.; S. T. Whitaker, vice-pres.; J. M. Scott, treas.; Ed. ar Mitchell, supt; Jacquard Specialties, Lap Robes, Portieres, Marseilles, Mitcheline Quilts, Table Covers Towels; 30 Jacquard looms; steam; sell direct. (Propose adding spinning.)
- RIVERDALE MILLS. (See Riverview, Ala.)
- WEST POINT MFG. Co.; \$500,000; L. (C) Lanier, pres.; H. S. Sears (Boston, Mass.), treas.; Thos. Lang, supt; Ducks; 33,000 ring spindles; 464 looms; water; Wellington, Sears & Co., Boston, s. agts; L. Lanier, buyer.
- White Hall.** E-11. M. & N. RR.
- GEORGIA MFG. Co.; \$120,000; J. R. White, (C) pres. and treas.; C. F. Smith, supt.; Yarns; 11,686 ring spindles; water; W. M. & F. W. Sharples, Catlin & Co, and Buckingham, Paulson & Co., s. agts.; J. R. White, buyer.
- WHITEHALL YARN MILL; John R. White, (C) pres. and treas.; Yarns; 78 to 20s, 2500 ring spindles; electric; Catlin & Co., s. agts.; John R. White, buyer.
- Winder.** D-10. Sea. Air Line, Ga. RR.
- RUSSELL MFG. Co.; 20,000; R. B. Rus. (K) sell, pres.; J. J. Corp, treas.; B. T. Camp, supt.; 176 needle; Full Hose and Half Hose; 50 knitting machines; 110 cylinders; steam; sell direct; B. T. Camp, buyer.
- WINDER COTTON MILLS; \$100,000; J. B. (C) Richards, pres.; W. M. McElroy, treas.; C. H. Robertson, supt.; Denims; 5000 ring spindles; 150 looms; steam; dye; Robinson & Shackelton, s. agts.; C. H. Robertson, buyer.

## IDAHO.

No map.

For explanation of abbreviations see page 66.

### Franklin. D. L. & G. RR.

TRENT MILLS; Parkinson & Lums; (W & K) \$2,000; F. C. Parkinson, pres.; Edmund Buckley, supt.; Wool Blankets, Flannels, Linseys, Yarns and Hosiery; 1 set; 5 looms; 240 spindles; 7 knitting machine; water; dye; sell direct.

### Paris. (10 miles from Montpelier), Oregon S. L. RR.

CROUCH, E.; knitting. (K)

### Post Falls. Northern Pacific RR.

POST FALLS WOOLEN MILL; Woolen (W & K) and Cotton Hosiery; 1 set; 2 looms (not in use); 14 knitting machines; steam; dye; sell direct. *Not in operation.*

### Rexburg. O. S. Line.

FREMONT KNITTING FACTORY; Under. (K) wear and Hosiery; 7 knitting machines.

## ILLINOIS.

See map on page 94.

For explanation of abbreviations see page 66.

- Aurora.** A-4. C. B. & Q. R.R.; C. & N. W. R.R.; E. J. & E. R.R.
- AURORA BLEACHERY & DYE WORKS;** (**H & D**) \$100,000; S. C. Gillett, pres.; E. S. Hobbs, treas.; steam; E. S. Hobbs, buyer.
- AURORA COTTON MILLS;** \$500,000; (**C**) E. W. Trask, pres.; E. S. Hobbs, treas. and buyer; Sheeting in all widths; 32,000 spindles; 800 looms; steam; Curtiss & Warren, Chicago, s. agts.
- AURORA WOOL SCOURING MILLS;** C. H. (**W**) Haring, treas. and gen. mgr.; G. W. Boynton, sec. and supt.; Wool Scouring, Carbonizing and Neutralizing.
- Chester.** F-2. W. C. & W. R.R.
- ROYAL KNITTING COMPANY;** \$10,000; (**H**) Percy C. Withers, pres. and treas.; F. H. Withers, supt.; Misses' and Boys' Ribbed Seamless Cotton Hosiery; 50 knitting machines; steam; dye; sell direct; P. C. Withers, buyer. (Buy Southern frame spun carded Peeler yarn, 8, 9, 10 & 17, on cones.)
- Chicago.** A-4. A. T. & S. Fc.
- AMAZON HOSIERY CO.** (See Muskegon, Mich.)
- BAUM, C. F., Co.;** 220 E. Madison (**S & H**) St.; \$40,000; C. F. Baum, pres. treas. and supt.; Silk, Mohair, Wool and Cotton Tinsel, Dress, Millinery and Cloak trimmings; 12 looms; 12 knitting machines; steam; sell direct and through agts; C. F. Baum, buyer. (Buy 16/3, 20/2, 40/2 cotton 3/20, 2/26 worsted yarn.)
- BAUER & BLACK;** 283 25th St.; Plain and (**C**) Medicated Absorbent Cotton; 12 cards; electricity; sell direct.
- BEHRMAN, J. M.;** Reliable Knitting (**H**) Works; 355 Maxwell St.; Sweaters; 8 hand knitting machines. (Buy 3/16 and 2/20 worsted and wool.)
- BURTON, THE CO.;** Centre Ave. and 21st (**C**) St.; \$50,000; J. Burton, pres.; O. M. Burton, treas.; Cotton Bats, Cotton Felts and Mattress Stock; steam; sell direct.
- CHICAGO EMBROIDERY CO.;** 492 W. Ohio (**S**) St.; \$20,000; John Bodenmann, pres. treas. and supt.; Silk Embroideries on Flannels, Mousseline de Soies, silks, etc.; 2000 needles; 12 embroidery machines; 20 sewing machines; electricity; John Bodenmann, buyer.
- CHICAGO FRINGE AND EMBROIDERY CO.;** (**S**) cor. Washington and Market Sts; \$10,000; L. Obendorf, pres. and treas.; F. Obendorf, sec.; Embroidry and Upholstery Trimmings; 28 looms.
- CHICAGO GLOVE & MITTEN CO.;** Wilt. (**H**) Shire, C; 170 N. Halstead St.; Knit Goods and Leather Gloves and Mittens; 20 knitting machines; 20 sewing machines; steam and gas; D. P. Jones, s. agt. (Buy 20/2 wool, 10/2 combination worsted.)
- CHICAGO NET & TWINE CO.;** \$10,000; Geo. (**C**) B. Carpenter, pres.; B. Carpenter, treas.; C. Reinold, supt.; All Kinds of Cotton and Linen Nets; Seine Twines, etc.; 6 knitting and 10 sewing machines; steam; dye.
- CHICAGO RUG MFG. Co.** (4524 Cottage (**W**) Grove Ave.); M. Iralsou, sec.
- COMMON SENSE TRUSS CO.;** 58 State St.; (**H**) \$20,000; Dr. A. H. Parker, pres. and treas.; Surgical Elastic Hosiery; 4 knitting machines; steam; sell direct.
- CUSTOM KNITTING WORKS;** 220 Hudson (**H**) Ave.; John Nepomuek, mgr.; High Grades Hosiery, Theatrical and Sporting Goods; 9 knitting machines; sell direct; (buy 2/18, 2/16, 3/16 and 4/16 worsted yarn).
- DEERING HARVESTER CO.;** Fullerton and (**J**) Clybourn Aves. Sisal and Manila Binder Twine.
- EDERER R. J. Co.;** 151 Wabash Ave.; (**C**) \$50,000; Henrietta Ederer, pres; Louis B. Ederer, treas.; A. E. Ederer, supt.; Fish Nets and Linen and Cotton Nettings; L. B. Ederer, buyer.
- EMPIRE KNITTING MILLS,** (successors to (**H**) S. Drury & Co.); 147 Van Buren St.; Sweaters, Golf Vests and Waists, and Cardigan Jackets; electricity; sell direct; J. Kaufman, buyer. (Buy wool and worsted yarns; 2/16, 3/18, 3/21, 2/20, 2/18.)
- ERICKSON MFG. Co.;** 1019 Washtenaw (**C**) Ave.; Knotted Cotton Hammocks, all sizes and attachments; 1 loom; gas; sell direct; Geo. Erickson, buyer.
- FETIG, THEODORE;** 1865 Ogdon Ave.; (**H**) Underwear and Sweaters; 40 knitting and 6 sewing machines; gas; sell direct.
- FIEDLER, A. B. & SONS;** office, 137-139 (**S**) Adams St.; mill, North Park Ave., Eugene and Hammond Sts.; \$200,000; M. A. Fiedler, pres.; Anton Fiedler, treas.; Edmund G. Fiedler, sec. supt. and buyer; Fringes, Cords, Tassels, Braids, Gimps, Buttons, Etc., Women's Dress Trimmings and Suspender Braids; 30 looms; steam; sell direct. (Buy cotton and worsted yarns.)
- FRIEDLANDER, BRADY & Co.;** 1241-1249 (**H**) State St.; \$160,000; Silk & Wool Gloves and Mittens; Leggings, Wristlets, etc.; 400 knitting machines; 15 sewing machines; steam; sell direct.
- GALLAGHER, D. J., MFG. Co.;** 283 So. Canal (**C**) St.; D. J. Gallagher, pres. and treas.; Geo. R. Gallagher, supt.; Cotton Waste; 3 waste machines; sell direct.
- JENSEN, JOS.;** 522 Milwaukee Ave.; (**H**) Shirts, Jackets and Hosiery; 25 knitting machines; hand power; sell direct.
- LORENZ, RICHARD;** Globe Knitting (**H**) Mill; 241 Clybourn Ave.; Sweaters, and Wool Socks; 24 knitting machines, 15 circular machines; sell direct.
- MANSURE, E. L., Co.;** Michigan Ave. and (**S**) Lake St.; \$100,000; E. L. Mansure, pres.; E. R. Rowe, treas.; H. F. Walliser, supt.; Upholstery and Drapery Trimmings; 10 looms; steam and electricity; sell direct; H. F. Walliser, buyer.
- MARBLE, E. M. & Co.;** and 90 to 98 Market (**H**) St.; Infants' Shirts; 7 knitting and 15 sewing machines; electricity; sell direct.
- MCCORMICK HARVESTING MACHINE CO.;** (**C**) Blue Island Ave.; Binder Twine; 1600 spindles.
- MERCHANTS' DYEING CO.;** 381 Sedwick (**D**) St.; \$30,000; T. D. Yates, pres. and mgr.; Woolen and Cotton Yarns, (capacity 10,000 lbs daily); Dress Goods, Ribbons, Burlaps, Sheetings, etc., (10,000 yds. daily).
- OLSON RUG CO.;** 375 W. Lake St.; O. B. Ol. (**W**) son, pres.; Rugs made from carpeting; Bert Olson, buyer.
- PARAMOUNT KNITTING CO.;** 912 Medinah (**C**) Temple Bldg.; \$100,000; H. Pope, pres.; C. Rupert, treas.; W. E. Clark, sec.; Cotton

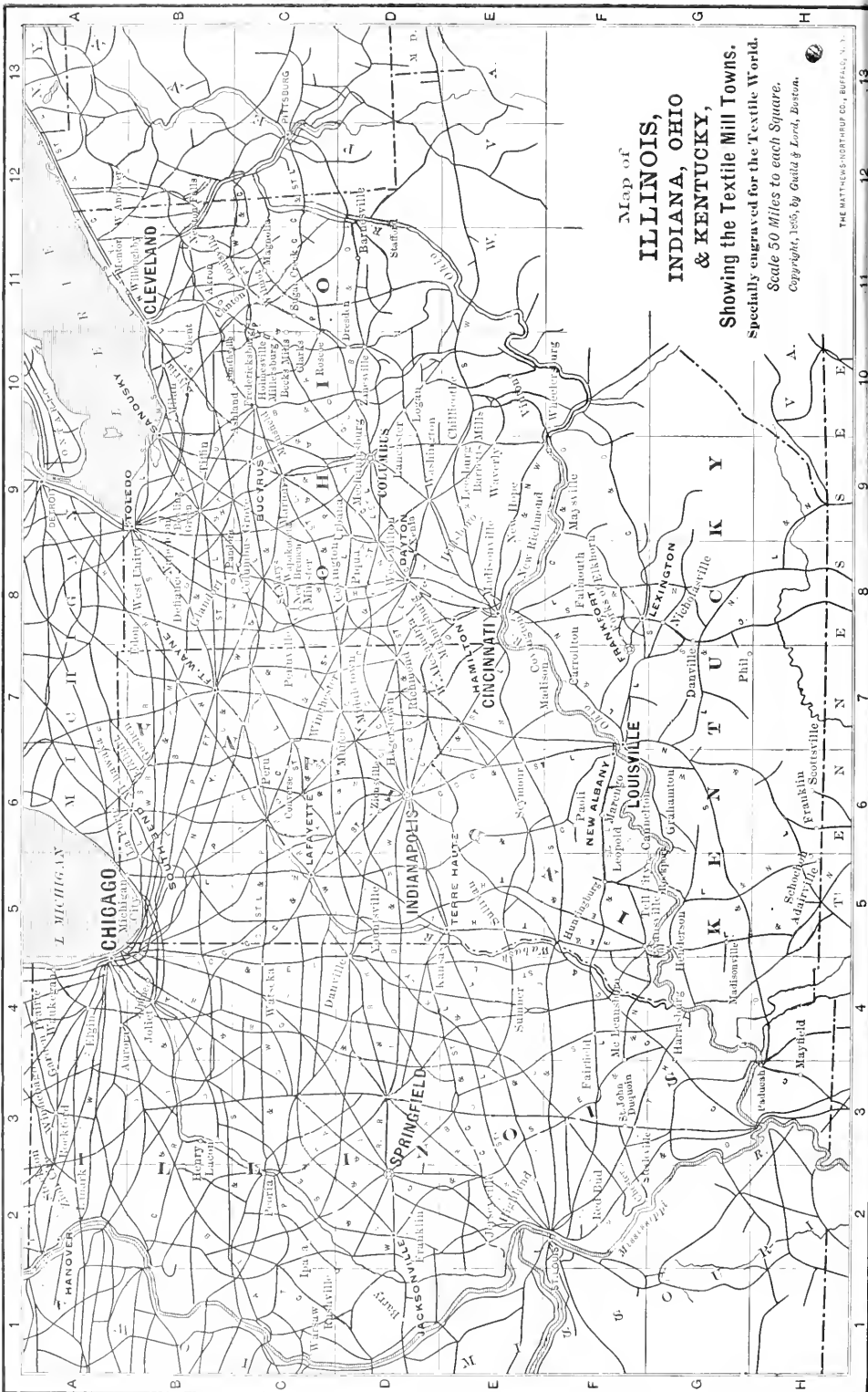

Map of  
**ILLINOIS,  
 INDIANA, OHIO  
 & KENTUCKY,**

**Showing the Textile Mill Towns.**  
 Specially engraved for the Textile World.  
 Scale 50 Miles to each Square.  
 Copyright, 1905, by Girdle & Lord, Boston.

- Hosiery; 200 knitting machines; steam; dye; sell direct; K. Kelly, buyer. (Buy 3 to 40s cotton yarn.)
- PETERS TRIMMING CO.**; 229 Fulton St.; (S \$75,000; M. Peters, pres.; Mrs. M. Peters, treas.; Wm. Wiedenhoff, supt.; Fringes and Drapery Trimmings; sell direct; Chas. E. Peters, buyer.
- PETERSON, P.**; Clybourne and Racine (W Aves; Mattress Shoddy; 3 pickers.
- PFEFER & CO.**; 4139 State St.; \$100.- (D & F 000; S. J. Pfeifer, pres.; W. S. Kilmer, treas. and buyer; Dyers, Cleaners and Launderers; steam.
- PHOENIX TRIMMING CO.**; \$25,000; 572 Cly-bourn Ave.; C. G. Boldenwick, pres. and treas.; Wm. Boldenwick, sec.; Upholstery Drapery and Decorative Trimmings; 75 looms; sell own goods; office, 572 and 576 Clybourn Ave.
- PHYLLIS KNITTING CO.**; 153-157 S. Jeffer-son St.; \$25,000; Max Abraham, pres.; Harry S. Stanton, treas.; Julius Abraham, supt.; Ribbed and Full Fashioned Underwear; steam; dye; sell direct; Julius Abraham, buyer. (Buy cotton, silk and worsted yarns.)
- ROSSITER, J. S. & Co.**; 254 Monroe St.; (K Knit Goods, Hoods, Fascinators, Etc; 15 knitting machines, also hand work; J. S. Rossiter, buyer.
- ROYAL KNITTING WORKS, THE**; Herman (K H. Newberger, prop; 483 So. Halsted St.; Sweaters, Cardigan Jackets, Hosiery and Bicycle Hose; 20 knitting machines; sell direct. (Buy 2 1/2, 2 1/8, 2/20 Wool Yarn, 2/16, 3/15, 4/16 worsted.)
- SAND, JOHN A.**; 683 W. Chicago Ave.; (K Stockings and Sweaters; 6 knitting machines; 1 rubber. (Buy wd. yarn.)
- SHARP & SMITH**; 92 Wabash Ave.; C. F. (K Bennett, supt.; W. N. Sharp, buyer; Elastic Stockings and Surgical Goods of all kinds; 12 knitting machines; 3 looms; 14 sewing machines; electric; sell direct. (Buy 16/2 50/2 60/2 Egyptian, 40-2 45/2 50/2 36/2 Peeler, all cotton yarns, plain and colored, spun and floss silks.)
- SHEFFNER & OLSWANG**; 318 W. 12th St.; A. (K Shefner, treas.; Sweaters and Men's and Children's Hosiery; 10 knitting machines; sell direct; M. Olswang, buyer. (Buy 2/20 and 2/16 worsted.)
- STANDARD MANTLE KNITTING CO.**; 161 Superior St.; \$225,000; A. Anderson, pres.; J. Bloch, treas.; Hoods for Incandes-cent Gas Lights; 16 knitting machines; sell direct.
- STEVENS, F. K.**; 896-898 N. Paulina (W & K St.; Woolen and Merino Yarns, Skeins, Cops and Cones.
- STRAUSS-CAHN KNITTING CO.**; 258-260 E. K Division St.; (successors to H. Strauss); \$50,000; Levy Strauss, pres.; E. B. Cahn, treas.; M. A. Stern, vice-pres.; Levy Strauss, supt.; Men's, Women's and Children's Cotton, Worsted and Silk Underwear, Jersey Sweaters and Worsted Hosiery; 30 knitting machines; electricity; sell direct.
- STYER LACE & DRAPERY CO.**; \$1500; (S Josephine Styer, Joseph Styer and Ada Burns; Laces.
- TRUAX, GREENE & Co.**; 42-46 W. (K ash Ave.; \$200,000; Chas. Truax, pres.; F. C. Greene, treas.; B. G. Green, supt.; Elastic Stockings and Supporters, Etc.; 3 looms.
- UNION FEATHER AND WOOL MFG. CO.**; (W 21 East Wabansia Ave.; \$10,000; S. Gold-man, pres.; P. Peterson, sec. and treas.; L. Reitz, supt.; Mattress Wool, etc.; 4 pickers; 1 lapper; 1 cotton duster.
- WESTERN ELECTRIC CO.**; 242 So. Jefferson (C St.; \$8,000,000; E. M. Barton, pres.; J. W. Johnston, treas.; W. R. Patterson, supt.; F. Lancaster, buyer; Insulated Wire, Cables and General Electrical Goods; steam; dye; sell direct.
- WESTERN FELT WORKS, THE**; 787-797 (W So. Canal St.; \$50,000; Harry Faurot, treas. and vice-pres.; Geo. M. Silverthorne, sec. and supt.; General line of Felts; 10 sets; steam; sell direct.
- WESTERN SHADE CLOTH CO.**; Shade Cloths (C and Window Shades; Columbia Shade Cloth Co. s. agts.
- WILSON BRAIDING & EMBROIDERY CO.**; (S Madison and Market Sts.; Embroideries, Etc
- Danville, D.4.** C. C. C. & St. L. RR.; C. & E. I. RR.; W. RR.
- DANVILLE WOOLEN MILL**; \$60,000; F. (W Menig, pres. and treas.; Geo. Menig, supt. and buyer; Cassimeres and Government Kerseys; 3 sets; 1500 mule spindles; 1 narrow and 14 broad looms; steam; dye; Stur-berg, Schell & Co., N. Y. s. agts.
- Duquoin, F.3.** Ill. Cent. RR.; St. L. A. & T. H. RR.
- GREENFIELD, J. H. & Co.**; Socks and (K Stockings; 5 knitting machines; hand power; dye; sell direct.
- Elgin, A.4.** C. & N. W. RR.; C. M. & St. P. RR.
- ELGIN COTTON MILLS**; Batting; 15 cards; (C 2 pickers; 3 sewing machines; dye; water and electricity; sell direct.
- Fairfield, F.4.** B. & O. RR.; L. E. & St. L. RR.
- FAIRFIELD WOOLEN MILLS**; T. R. Jones (W and A. H. Baker; 8 sets; 210 looms; 4100 worsted spindles; steam; dye.
- Franklin, D.2.** J. L. & St. L. RR.
- MANSFIELD, I. T. & Son**; 1 set. (W
- Garden Prairie, A.3.** C. & N. W. RR.
- SACKETT WIRED TAG CO.**; Separator Belts (C for mill separators. (Buy soft cotton cord or twine.)
- HANOVER (Jo Davies County).** A.2. C. B. & N. RR.
- HANOVER WOOLEN MFG. CO.**; \$80,000; R. (W H. McClellan, pres.; J. W. White, treas. and agt.; J. W. White, buyer; Cassimeres; 8 sets; 36 looms; steam and water; dye; sell direct.
- Harrisburg, G.4.** C. C. C. & St. L. RR.
- DURFEE, J. A.**; Harrisburg Woolen (W Mills; 1 set. Mill idle.
- Henry, B.3.** C. R. I. & P. RR. (6 miles from Lacon.)
- HENRY CARPET SHOP**; W. H. Spencer, (W prop. and mgr.; Rag and Jute Carpets, In-grain Rag and Chenille Rugs; 3 looms; W. H. Spencer, s. agt.
- Highland, E.2.** T. H. & Ind. RR.
- HIGHLAND EMBROIDERY WORKS**; J. J. (S Spindler, Jr, pres.; L. J. Ruhr, sec. and treas.; Fine Embroidered Flannels; 18 looms; Ryan & McGahan, N. Y.; N. C. D. Griffith, Chicago; J. C. Speight San Francisco, s. agts.
- Ipava, C.2.** C. B. & R. RR.
- FOOTE, C. F.**; Ipava Woolen Mills; (W Homespun; 788 mule spindles; 2 sets; 9 broad looms; steam; dye; sell direct; (Branch mill at Rushville.)
- Jacksonville, D.2.** C. & A. RR.; C. P. & St. L. RR.; J. & St. L. RR.; W. RR.
- GARDEN CITY KNITTING WORKS**; Mrs. (K H. C. Bohne Taylor; Silk, Wool, Cotton and Mixed Jersey Ribbed, Full Fashioned Underwear; 6 knitting machines; 1 looper; 2 sewing machines; sell direct.
- CAPPS, J. & SONS (Ltd.)**; \$200,000; J. (W L. Capps, pres.; J. G. Capps, treas.; A. T. Capps, sec.; Paul Alexander, supt.; Cassimeres and Worsteds; 7 sets; 36 looms; steam; dye; S. R. Capps, buyer of supplies; H. M. Capps, buyer wool; J. G. Capps, trimmings; sell direct.

- Joliet.** B.4. A. T. & S. Fe RR; C. & RR; E. J. & E. RR.
- BERTNICK, R.**; 407 Cass St; Rag Carpets (**W**) and Rugs; 3 looms; dye.
- Lacon.** B.3. C. & A. RR.
- GRIEVES, JNO. & Co.**; Ettrick Mills; (**W**) Men's and Ladies' Wear, principally Mens'; 2 sets; 12 looms; steam; dye. (Re-built burned plant)
- Lanark.** A.2. C. M. & St. P. RR.
- WOLFEY, J. D.**; Carpets and Rugs; 2 (**W**) looms; buy warps. (Mostly custom work.)
- McLeansboro.** F.4. L. & N. RR.
- HALL, STEPHEN**; Blankets, Jeans, Flannels, Yarns; 2 sets; 6 looms; 1 knitting machine; 280 spindles; steam; dye; sell direct.
- Metropolis.** G.3. St. L., A. & T. H. RR.
- METROPOLIS WOOLEN MILL**; D. B. Klutts & Co. (*Out of business.*)
- Peoria.** G.2. C. B. & Q. RR.; C. R. I. & P. RR.; C. P. & St. L. RR.; C. C. C. & St. L. RR., and others.
- PEORIA CORDAGE Co.**; \$400,000; Martin (**J**) Kingman, pres.; G. H. Schimpff, treas.; E. C. Heidrich, gen. mgr; E. C. Heidrich, Jr., sec.; Sisal and Manila Ropes and Twine; steam; sell direct; E. C. Heidrich, buyer.
- Red Bud.** F.2. Mobile & O. R. R.
- OFFERMAN, MRS. WM.**; Men's Heavy Wool (**K**) Half Hose; 10 knitting machines; steam; sell direct. (Buys yarn.)
- Rockford.** A.3. C. & N. W. RR.; C. B. & Q. RR.; C. M. & St. P. RR.; I. C. RR.
- BURSON KNITTING Co.**; \$500,000, author (**K**) ized (\$273,300 paid in); Wm. Ziock, pres.; W. E. Hinchliff, treas., agt; E. J. Ziock, supt. and buyer; Full Fashioned, Seamless, Cotton Hosiery; 400 knitting machines; steam; dye; sell direct and Curtiss & Warren, Chicago and N. Y., s. agts. (Buy Southern cones, 6s to 24s; Northern mule spun, 10s to 60s.)
- DYSON & PLATT** (successors to Rockford Woolen Mill Co.); Owen Platt, mgr; Wm. Dyson, buyer; Uniform Goods for Army Officers, Cadets, Post Office Employees, Etc., also Shawls; 3 sets; 12 looms; water; dye; Curtiss & Warren, Chicago and N. Y., s. agts.
- FOREST CITY KNITTING Co.**; \$60,000; Wm. (**K**) Nelson, pres.; F. P. Nelson, treas.; Oscar Nelson, supt; Cotton Hosiery; 125 knitting machines; steam; Curtiss & Warren, Chicago and N. Y., s. agts. (Buy 5 to 12s yarn.)
- NELSON KNITTING Co.**; main office, Rockford, Ill.; \$160,000; F. R. Brown, pres.; Wm. Nelson, vice-pres.; A. S. Ruhl, sec., treas. and buyer; Patent Seamless Cotton Hosiery; 500 knitting machines; water and steam; Curtiss & Warren, 214 Church St., N. Y., and 185 Van Buren St., Chicago, s. agts.
- PRICE, THE H. W. Co.**; \$125,000; Henry (**K**) W. Price, pres. and treas.; K. L. Swarthout, sec.; Mittens, Rugs and Gloves; 30 knitting machines.
- ROCKFORD COTTON MILLS**; \$2,500; John (**C**) Lowe, pres.; G. B. Gregory, sec.; Cotton Bating; 3 cards; water; sell direct and agts.
- ROCKFORD MITTEN & HOSIERY Co.**; \$300,000; Wm. Ziock, pres. and treas.; W. H. Ziock, supt.; Worsted, Wool, Merino Hose and Half Hose; 12 sets; 500 knitting machines; (French system); 3 combs; 2 worsted cards; 1800 worsted spindles; steam; dye; sell direct and Curtiss & Warren, Chicago and N. Y., s. agts; Wm. H. Ziock, buyer.
- Rushville.** D.1. C. B. & Q. RR.
- FOOTE, J., & Son**; (Branch of Ipava Woolen Mill.) C. E. Foote, supt., mgr. and buyer; Warp Yarns; 1 set; steam; dye and finish; sell direct.
- Springfield.** D.2. B. & O. RR.; C. & A. RR.; C. P. & St. L. RR.; I. C. RR.; St. L. C. & St. P. RR.; W. RR.
- GODLEY, FRANK**; Shoddy; 6 sets. (**W**)
- SPRINGFIELD WOOLEN MILLS**; \$100,000; (**W**) E. R. Thayer, pres.; J. T. Capps, treas.; H. Engelskirchen, supt; treas. and supt. buyers; All Wool Cassimeres; 6 sets; 26 broad and 1 narrow looms; steam; dye; sell direct.
- Steeleville.** F.2. W. C. & W. RR.
- THIES, CHAS. H. & SON**; Wm. Bennett, (**W**) supt.; Chas. H. Thies, buyer; Jeans, Flannels, Blankets and Yarns; 1 set; 6 looms; 2 knitting machines; steam; dye; sell direct.
- Stockton.** A.2. C. G. W. RR.
- STOCKTON WOOLEN MILL**; Blankets; (**W**) 2 sets; 16 looms; steam; dye. *Idle.*
- Summer.** E.4. B. & O. RR.
- SAXTON, H. W.**; \$5000; Blankets, Jeans, (**W**) Yarns and Rolls; 2 sets; 5 looms; steam; dye; sell direct.
- Winnebago.** A.3. C. & N. RR.
- DRAKE, MRS. N. BIRKITT**; Opera Shawls; (**K**) Knit Hoods, Fascinators, Infant's Wear; hand power; sell direct.
- Zion City.** A.2. Z. C. L. Co.; Ill. RR.; C. & N. W. RR.
- ZION LACE INDUSTRIES**; \$1,000,000; John (**C**) Alex. Dowie, pres.; C. J. Barnard, treas.; Arthur & Henry Stevenson, mgrs.; All Kinds of Fancy Nottingham Laces and Edgings, Wide and Narrow Valenciennes, Torchons, All Over Nets, Insertions and Serpentine Laces, Lace Curtains, etc.

## INDIANA.

See map on page 94.

For explanations and abbreviations see page 66.

- Cannelton.** G.5. Southern RR.
- INDIANA COTTON MILLS**; \$300,000; Geo. (**C**) W. Morris, pres.; Edward W. Chamberlain, treas.; Geo. F. Smith, supt.; Bating and Brown Sheetings; 35,168 ring spindles; 404 looms; steam; sell direct and H. McK. Jones & Co., St. Louis; Taylor & Bro., Cincinnati, and Jenkins, Kreer & Co., Chicago, s. agts.
- Converse.** C.6. P. Ft. W. & C. RR.
- WARDWELL & Co.**; Blankets, Flannels, (**W**) Yarns, etc.; 1 set; 5 looms; steam; dye. *Not running. For sale.*
- Elkhart.** B.6. C. C. C. & St. L. RR.; L. S. & M. S. RR.
- LAKESIDE KNITTING Co.**; Branch Mill. (**K**) See also Michigan City.



**Evansville.** F-5. C. O. & S. W. RR.; E. S. & N. RR.; E. & T. H. RR.; L. & N., L. E. & St. L. RR.; P. D. & E. RR.

**EVANSVILLE COTTON MFG. CO.;** \$250,000; (C) C. F. Heilman, pres.; A. W. Emery, sec. and treas.; John H. Osborn, supt.; Drills, Sheetings, Batting; 39,000 spindles; 900 looms; steam; self direct.

**EVANSVILLE WOOLEN MILL CO.;** \$150,000; (W) J. A. Lemcke, pres.; B. A. James, vice-pres.; Walter M. Schmitt, treas. and buyer; R. E. Schouler, supt.; Cassimeres; 7 sets; 80 narrow and 18 broad looms; steam; dye; L. W. Johnson, s. agt. (Buy 1½-18 and 2 ply 20s black yarn.)

**Fort Wayne.** B-7. F. Ft. W. & W. RR.; G. R. & I. RR.; L. E. & W. RR.; L. S. & M. S. RR.; N. Y. C. & St. L. RR.; P., Ft. W. & C. RR.; W. RR.

**UNITED KNITTING MILLS;** \$75,000; W. E. (K) Mossman, pres.; F. S. Hunting, treas.; F. J. Thieme, supt.; Full Fashioned Children's Hosiery; 126 knitting machines; electric power; self direct; F. J. Thieme, buyer. (Buy 1/8 to 1/30, 2/30, 2/36 yarns.) After May 1st, 1902, will consolidate with Wayne Knitting Co.

**WAYNE KNITTING MILLS;** \$350,000; H. C. (K) Paul, pres.; Wm. A. Spier, vice-pres.; T. F. Thieme, mgr., sec. and buyer; Full Fashioned Hosiery; steam; dye; self direct. After May 1, '02, will consolidate with United Knitting Mills.

**Goshen.** B-6. C. C. C. & St. L. RR.; S. S. & M. S. RR.

**GOSHEN WOOLEN MFG. CO.;** \$37,500; Ed. (W) R. Kerstetter, pres.; J. L. Kerstetter, treas. and supt.; Blankets, Flannels, Head Shawls, Skirts and Wool Mattresses; 3 sets; 4 knitting machines; 14 narrow and 7 broad looms; steam; dye; self direct. *Idle. For sale.*

**Huntingburg.** F-5. L. E. & St. L. RR.

**MEISSNER BROS. Co., THE;** Huntingburg (W) Woolen Mills; C. Miessner, supt.; Yarns, Blankets, Jeans, Skirts; 500 spindles; 2 sets; 5 looms; self direct.

**Huntington.** C-7. Erie RR., W. RR.

**HUNTINGTON KNITTING MILL CO.;** \$30. (K) 000; Fall Fashioned Hosiery. (Expect to be running by July.)

**Indianapolis.** D-6. C. H. & D. RR.; I. D. & W. RR.; V. L. L. E. & W. RR.; L. N. A. & C. RR.; C. C. C. & St. L. RR.; P., Ft. W. & C. RR.

**INDIANA WARP MILLS;** Brower & Love (C) Bros.; Hugh M. Love, supt.; Jeans, Warps, and Brown Sheetings; 55,000 ring spindles; 1,000 looms; steam; dye; self direct; John R. Love, buyer.

**INDIANAPOLIS BLEACHING CO.;** \$60,000; (B) S. A. Bemis, pres.; J. R. Love, treas. and mgr.

**MERRITT, GEO. & Co.;** \$100,000; Geo. Mer. (W) rit, pres.; Worth Merritt, treas.; Flannels, Dress Goods, Lustré Wool Petticoats and "Health Comforts"; 3 sets; 14 broad and 5 narrow looms; water and steam; dye; self direct; heads of depts., buyers. (Buy 32/2 lustré worsted yarn.)

**MODEL WOOLEN MILL;** 4 sets; 20 (W) looms; steam; dye. *For sale.*

**Lafayette.** C-5. C. C. C. & St. L. RR.; L. E. & W. RR.; L. N. A. & C. RR.; W. RR.

**LAFAYETTE CARPET CO.;** \$60,000; A. Tur (W) kington, pres.; C. Murdoch, treas.; C. Web- er, supt.; Ingrains and Art Squares; 35 looms; steam; dye; buy warps and filling; S. C. Curtis, Son & Co., s. agts.; A. Turkington, buyer.

**LAFAYETTE UNDERWEAR CO.;** \$60,000; (K) Mortimer Levering, pres.; B. F. Cavins, treas.; R. E. Hill, supt.; Men's Fine Ribbed and Flat Knit Underwear, Patent Union

Suits a Specialty; 37 knitting and 51 sewing machines; steam; dye; self direct.

**La Porte.** B-5. C. & W. M. RR.; I. I. & I. RR.; L. E. & W. RR.; L. S. & M. S. RR.

**FOX'S, SAMUEL, SONS;** La Porte Woollen (W) Mills; \$100,000; Maurice Fox, pres.; Herbert W. Fox, treas.; John Riley, supt.; Ladies' Dress Goods; 5 sets; 16 broad and 20 narrow looms; steam; dye; self direct; Fox Bros., buyers.

**KING & FIELDS CO.;** \$200,000; John (W) Fields, Jr., pres.; E. D. Barrows, treas.; Flannels, Dress Goods; etc; 10 sets; 26 broad and 30 narrow looms; steam; dye; self direct.

**Leopold.** F-6. L. & E. M. Line.

**GENET, JOHN J., & Son;** custom carder; (W) 1 set.

**Madison.** F-7. P., Ft. W. & C. RR.

**EAGLE COTTON MILLS CO.;** \$250,000; Rich. (C) ard Johnson, pres.; David Johnson, treas., supt. and buyer; Brown Sheetings, Carpet Warps, Twines, Single Yarns, Candle Wicks, Batting; 20,000 ring spindles; 500 looms; steam; dye; self direct and J. H. Lane & Co., Chicago and N. Y., s. agts.

**JOHNSON, R. YARN & CORDAGE MILLS;** (C) W. J. Johnson, gen'l mgr. and buyer; Yarns and Twines; 5,000 ring spindles; steam; dye; self direct.

**ROSS TEXTILE MFG. CO.;** \$100,000; John (W) B. Ross, pres.; John I. Ross, treas.; Blankets, Cheviots, Cassimeres and Fine Horse Blankets; 6 sets; 59 looms; steam; dye; self direct. *For sale.*

**SCHOFIELD J. & SON;** John T. Schofield, (W) supt. and buyer; Blankets, Skirts and Flannels; 2 sets; 12 broad and 8 narrow looms; steam; dye; Putnam, Hooker & Co, Cincinnati, Chicago and St. Louis, s. agts.

**Michigan City.** B-5. L. E. & W. RR.; L. N. A. & C. RR.; M. C. RR.

**LAKESIDE KNITTING CO.;** \$75,000; H. L. (K) Marshall, pres.; L. L. Woods, treas.; J. C. Dohn, supt.; Knit Gloves, Mittens and Hosiery; 3000 male spindles; 5 sets; 200 knitting machines; steam; dye; self direct to jobbing trade. (See also Elkhart.)

**TECUMSEH FACING MILLS;** R. W. Street, (K) pres. and treas.; W. G. Kendrick, sec.; Linings for Leather Gloves and Mittens; 10 machines; self direct.

**Middletown.** D-7. P., Ft. W. & C. RR.

**LIEBHART BROS.;** Flannels; 1 set; (W) steam; dye; self direct.

**Mishawaka.** B-6. C. & G. T. RR.; E. & W. RR.; L. S. & M. S. RR.

**BEATTY FELTING Co.;** \$50,000; D. Beatty, (W) pres. and supt.; E. L. Beatty, treas. and buyer; Felt Boots, Shoes and Slippers; 7 cards; water; dye; self direct.

**MISHAWAKA WOOLEN MFG. CO.;** \$700,000; (K) M. V. Beiger, pres.; Marvin Campbell, treas.; F. G. Eberhart, Jr., supt.; Wool Boots, Lumbermen's Socks and Rubber Footwear; 18 sets; 160 knitting machines; water and steam; dye; self direct.

**Muncie.** D-7. C. C. C. & St. L. RR.; L. E. & W. RR.

**MUNCIE UNDERWEAR Co.;** A. J. Cameron (K) & Co.; \$100,000; A. J. Cameron, pres.; Thos. Henry, mgr., supt.; Men's and Children's Cotton Ribbed Underwear, Ladies' Skirts and Children's Waists; 17 knitting machines; steam; dye; self direct.

**New Albany.** F-6. B. & O. RR.; K. M. RR.; L. E. & St. L. RR.; L. N. A. & C. RR.; P. Ft. W. & C. RR.

**BOWMAN, D. F.;** Railroad Packing and (C) Wiping Waste; 5 waste machines; steam; self direct.

- HOOSIER DYE WORKS AND MFG. (W & D Co; Carpet Warp in Skeins and on Tubes, Drug Twine and Colored Hosiery Yarns; steam and electricity; dye; sell direct and McCord & Wright, Louisville, Ky., s. agts. (Buy bulk carpet warp no. 8, 8 1/2 and 9.)**
- NEW ALBANY HOSEY MILLS; \$100,000 (K authorized); J. F. Gebhart, pres.; W. A. Hedden, sec., treas. and buyer; Woolen Hosiery; 4 sets; 175 knitting machines; steam; dye; sell direct.**
- NEW ALBANY WOOLEN MILLS COMPANY; (W \$200,000; Joseph Sabel, sec. and treas.; J. F. Gebhart, supt. and gen. mgr.; Flannels, Jeans, Blankets, Skirts, Kerseys, Cassimeres; 18 sets; 224 narrow and 62 broad looms; steam; dye; sell direct.**
- OHIO FALLS WARP MILL; (owned and C operated by New Albany Woolen Mill Co); Hosiery Yarns, Jeans and Warps; 6500 spindles; steam; dye.**
- Paoli. F.6. L. N. A. & C. RR.**
- PAOLI MILLING Co. (formerly Frank M. (W King); custom carder; 1 set.**
- Pennville. C.7. G. R. & I. RR.; L. E. & W. RR.**
- BRIGGS & MENDENHALL; S. W. Briggs, (W supt; Blankets, Flannels, Yarns, and Jeans; 1 set; 5 looms; steam; dye. T. P. Mendenhall, buyer. *Not running.***
- Peru. C.6. L. E. & W. RR.; W. RR. Cim. R. & M. RR.**
- PERU BAGGING MFG. CO.; \$100,000; Chas. (J J. Kraus, pres.; Max W. Kraus, sec. and treas.; Jute Bagging; 824 spindles; 20 looms; 2 sets; steam; sell direct.**
- RACINE WOOLEN MILLS; (purchased (W plant Turner Mfg. Co.); Mens' Wear, Woolens and Blankets; 3,500 mule spindles; 7 sets; 32 broad looms; steam; dye. (See also Racine, Wis.)**
- Richmond. D.7. G. R. & I. RR.; P., Ft. W. & C. RR.**
- RICHMOND FLAX MILLS; John T. Case. (F I ly, mgr; Flax Tow and Upholstery Stock.**
- Rockport. F.5. L. E. & St. L. RR.**
- ROCKPORT WOOLEN MILLS; H. Kressel (W & Co; Woolen Goods; 4 sets; 24 looms. (No report, 1902.)**
- Seymour. E.6. B. & O. RR.; P. C. C. & St. L. RR.**
- SEYMOUR WOOLEN FACTORY Co.; \$79,250; (W Louis Schneck, pres.; John Vesting, treas.; Louis Schneck, buyer; Blankets, Flannels, Skirts and Skirtings, Yarns, etc; 10 sets; 60 looms; steam; dye; sell direct.**
- South Bend. B.6. C. & G. T. RR.; I. I. & I. RR.; L. S. & M. S. RR.; M. C. RR.; V. L. RR.**
- SOUTH BEND WOOLEN Co.; \$40,000; H. (W G. Niles, pres.; Geo. W. Lewis, treas.; H. G. Niles, Jr, sec.; W. W. Lewis, vice-pres. and mgr.; A. E. Dimock, supt.; Fancy Cassimeres; Fancy Overcoatings; 10 sets; 51 looms; steam and water; dye; sell direct.**
- STALEY A. C., MFG. Co.; \$40,000; M. B. (K Staley, pres. and supt; B. C. Stephenson, treas.; A. H. Stephenson, sec; Medium and High Grade Flat and Rib (Worsted) Underwear and Jersey Knit Overshirts; 6 sets; 43 knitting machines; water; dye; sell direct to retail; buy 1-6 cotton and 1-25 worsted yarn; M. B. Staley and A. H. Stephenson, buyers.**
- Sullivan. E.5. E. & T. H. RR.; I. & I. S. RR.**
- BRUNGER, S., & Co.; Sullivan Woolen (W Mills; Jeans, Flannels, Blankets, Skirting and Stocking Yarn; 2 sets; 9 looms; steam; dye; sell direct.**
- Tell City. G.5. L. E. & St. L. RR.**
- TELL CITY WOOLEN MILLS; \$50,000; Clay (W Switzer, pres.; M. Bettinger, Sr., treas.; M. Bettinger, Jr., sec.; Wm. Bettinger, supt. and buyer; Jeans; 2 sets; 46 looms; steam; dye; sell direct and B. A. Kaiser, New Orleans, R. P. Hannenham, Jr., St. Louis, J. Spencer Turner Co., N. Y. and Chicago, s. agts.**
- Winchester. D.7. C. C. C. & St. L. RR.; G. R. & I. RR.**
- CARTER, J. D.; Winchester Woolen Mill; (W Yarns, Blankets, Flannels, etc; 2 sets; 10 looms; steam; dye; sell direct.**
- Yountsville. D.5. C. C. C. & St. L. RR.; L. N. A. & C. RR.; V. L. RR.**
- YOUNT WOOLEN MILLS Co.; \$40,000; (W Andrew Yount, pres. and treas.; Robert P. Grant, supt., Pure Fleece Wool Goods, Dress Goods, Cassimeres and Flannels; 3 sets; 10 looms; water; dye; sell direct; Andrew Yount and Robert P. Grant, buyers. (RR. station, Crawfordsville, four and one-half miles.)**

## INDIAN TERRITORY.

No map.

For explanation of abbreviations see page 66.

- Davis. A. T. & S. F. RR.**
- INDIANOLA COTTON MILLS; \$300,000; (C Brown Domestic; 23,000 spindles; 750 looms. (Expect to start about Sept., 1902.) (Plant from Janesville, Wis., removed here.)**

## IOWA.

No map.

For explanation of abbreviations see page 66.

- Amana. C. M. & St. P. RR.**
- AMANA SOCIETY WOOLEN MILLS; John (W Heeneman, pres; Abraham Noe, treas.; Chas. Moershel and H. Leonhard, supts.; Flannels, Cassimeres; Blankets, Suitings; 7 sets; 48 looms; steam and water; dye; sell direct.**
- Bonaparte. C. R. I. & P. RR.**
- MEER BROS.; \$250,000; H. H. Meek, pres.; (W K. Meek, treas.; W. R. Dredge, supt.; Flannels, Hosiery Yarn, Cassimeres, Satinets, Jeans; 6 sets; 32 looms; 30 sewing machines; steam; dye; sell own goods.**
- Dale. C. R. I. & P. RR.**
- LONSDALE'S, JOHN, SONS; Woolens, (W Flannels, Blankets, Yarns, Skirting and Cassimeres; 1 set; 5 looms; water; dye; sell direct. (Glendon three and one-half miles, Linden six miles distant.) (Buy a small amount of mohair only.)**
- Davenport. C. M. & St. P. RR.; C. R. I. & P. RR.; B. C. R. & N. RR.**
- BOUDINOT, H. R. (successor to H. Bondi. (F not & Son); Cordage, Braided Halter and Taper Leads; R. H. Boudinot, buyer.**

**DAVENPORT WOOLEN MILLS CO.**; \$60,000; (**W**) S. A. Jennings, pres.; W. K. Haight, treas.; J. J. Dalton, supt. and buyer; Blankets, Flannels, Cassimeres and Clothing; 5 sets; 2000 spindles; 22 broad looms; steam; dye; R. S. Price, 235 Franklin St, Chicago, Ill, s. agt.

**ECONOMY RUG CO.**; \$10,000; W. M. Fow. (**W**) ler, pres.; A. H. Fowler, treas.; H. C. Brice-land, sec.; Rugs made from Old Carpets; 3 looms.

**Decorah.** B. C. R. & N. RR, C. M. & St. P. RR.

**AMERICAN PULP AND LINEN FIBRE CO.**; (**L**) See Freeport.

**Des Moines.** C. & N. RR.; C. R. I. & P. RR.; C. B. & Q. RR.; C. G. W. RR.; D. M. & K. C. RR.; D. M. N. & W. RR.

**CAPITAL CITY WOOLEN MILLS;** Sheuer. (**W**) man Bros, proprs; S. S. Sheuerman, supt; Blankets, Flannels, Cassimeres, Ladies' Dress Skirts and Pants; 4 sets; 22 looms; 70 sewing machines; steam; dye; sell direct. L. Sheuerman, buyer.

**DES MOINES HOSIERY MILLS;** \$200,000; (**K**) authorized (\$142,000 paid up); James Callahan, pres.; H. M. Rollins, treas.; R. B. Dennis, sec. and agt.; J. F. Norton, supt; R. B. Deonis, buyer; Cotton and Wool and Mixed Seamless Hosiery; 197 knitting machines; steam; dye; sell direct. (Buy 5 to 40 Domestic, 10 to 40 Egyptian, 20 to 40 Worsted and 10 to 20 Woolen and Merino yarn.)

**IOWA KNITTING CO.**; 430 E. Grand St; (**K**) \$30,000; D. M. Finch, pres; E. C. Musgrove, treas; L. A. Bentz, supt; Ladies', Men's and Misses' Cotton Hosiery; 75 knitting machines; steam; dye; sell direct; D. M. Finch, buyer. (Buy 5/1 to 40/1 yarn.)

**Dubuque.** C. G. W. RR.; C. M. & St. P. RR.; Ill. Cen.

**BESTIVAL MILL;** L. M. Johnson, mgr.; (**F**) Seamless Grain Bags; 10 looms; 432 spindles; steam; sell direct.

**Elma.** C. G. W. RR.

**NORTHWESTERN TOW CO.**; \$150,000; J. K. (**F**) Brady, president; J. C. Webster, vice-pres.; A. G. Brown, sec. and treas.; J. T. Smith, gen'l mgr.; Upholstery and Spinning Twine. (Mills at Dodge Center, Fulkia, Heron Lake, Kenyon, Minn., Cresco, Elma and McIntyre, Iowa, and Hammond, Wis.) Main office, Elma. Sell direct and Jacob Keim, 462 Wabash Ave., Chicago, Ill.

**Farmington.** C. B. & Q. RR.; C. R. I. & P. RR.

**STIRLING WOOLEN MILLS CO.**; \$50,000; (**W**) John Stirling, pres. and supt.; Geo. Stirling, sec. and buyer; Cassimeres, Flannels, Blankets, Yarns, Pants and Suits; 2 sets; 960 spindles; 13 looms; 18 sewing machines; steam; dye; sell direct.

**Fayette.** C. M. & St. P. RR.

Klock, Geo. (Est. 06); Cassimeres, (**W**) etc; 1 set; 2 looms.

**Fort Madison.** A. T. & S. Fe RR.; C. B. & K. C. RR.; St. L. K. & N. RR.

**IOWA STATE PENITENTIARY;** N. N. Jones, (**K**) warden; Hosiery. (Buy yarn.)

**Freeport.** B. C. & N. RR. & St. P. RR.

**UNION FIBRE CO.**; (successors to Ameri (**L**) can Pulp, Linen & Fibre Co.); Phil Allen, Jr., pres.; J. J. Brown, treas.; A. G. Brown, sec.; Flax Fibre and Mineral Wool for Insulating Purposes only. General office, Winona, Minn.

**Homestead.** C. R. I. & P. RR.

**AMANA SOCIETY WOOLEN MILLS.** See (**W**) Amana.

**Iowa City.** C. R. I. P. RR.; B. C. R. & N. RR.

**GUZEMAN, J. H.**; Pioneer Knitting (**K**) Works; Hoods, Fascinators, Silk and Wool Mittens; Leggings, Scarfs; 12 knitting machines; sell direct; J. H. Guzman, buyer. (Buy 2/15 and 2/28 Floss and 3/27 Sax. Zepher and Germantown.)

**Lake Mills.** C. & N. RR.; M. & St. L. RR

**LAKE MILLS WOOLEN MILL CO.**; John R. (**W**) Larson; Jno. Kennedy and others; Blankets, Flannels, Knit and Make Yarns; 1 set; 3 looms. (Purchased Albert Lea Woolen Mills and removed same.)

**Lattner's.** C. G. W. RR.

**LATTNER, JACOB;** Woolen Yarns, Blank. (**W**) ets and Flannels; 1 set; 120 ring spindles; 3 looms; water; dye; sell direct. (RR. station, Graf, one-half mile distant.)

**Lemars.** St. P. C. M. & O. RR; Ill. Cen.

**MATHWIG, L. H.**; Le Mars Dye Works. (**D**)

**Manchester.** I. C. RR.

**MANCHESTER WOOLEN MILLS;** J. S. (**W**) Jones, successor to D. W. Jones & Sons; All Wool Goods; 680 ring spindles; 3 sets; 11 looms; water; dye.

**Nashua.** Ill. Cen. RR.

**NASHUA WOOLEN MILLS;** W. J. Bowen, (**W**) prop; Cassimeres, Horse and Bed Blankets, Flannels, Prison Cloth, Dress Goods and Yarns; 3 sets; 14 looms; water and steam; dye. (Purchased and operating plant of Nashua Woolen Mill Co.)

**Village Creek.** RR. Station, Lansing. C, M. & St. P. RR.

**DOEHLER BROS;** 1 set; 6 looms; water; (**W**) dye. (Freight address, Lansing.)

**West Mitchell.** I. C. RR.

**PARAGON WOOLEN MILLS;** S. D. Dun. (**W**) can, owner; \$2000; Cassimeres, Flannels, Blankets and Yarns; 200 spindles; 1 set; 3 looms; water; dye; sell direct.

**West Point.** C. RR.; F. M. & D. M. RR.

**WEST POINT WOOLEN MFG. CO.** Machinery sold and removed to W. J. Bowen's mill, Nashua, Iowa.

## KANSAS.

No map.

For explanation of abbreviations see page 66.

**Atchison.** A. T. & Santa Fe RR; B. & M. and M. P. RR.

**BACKUS BROS;** Flax and Excelsior. (**F**)

**Coffeyville.** A. T. & S. Fe RR.

**COFFEYVILLE COTTON MFG. CO.**; E. B. (**C**) Shaw, interested; 10,000 spindles. Pro posed.

**Independence.** A. T. and S. Fe.; M. P. RR.

**KANSAS TWINE CO.**; J. A. Stone, pres.; (**C**) Geo. T. Guernsey, treas.; I. B. Wallace, agt.; W. F. Dennis, supt.; Cotton Wrapping Twine; 2064 spindles; sell direct; W. F. Dennis, buyer. (Leased mill from Kansas Cotton Mill Co.)

**Lansing.** A. T. & S. Fe RR.

STATE PENITENTIARY; G. A. Meyers, (F1 &amp; J) supt.; Binder Twine.

**Newton.** A. T. & S. Fe. and M. P. RRs.

BEILER, S. R.; Rag and Jute (W &amp; J) Carpets and Rugs; 2 looms.

**Oakland.** (Four miles N. E. of Topoka.)

TOPEKA WOOLEN MILL CO.; \$37,000; Geo. (W) Neil, pres.; O. W. Neil, treas.; J. F. McAfee, supt. and buyer; Cassimeres, Pants, etc 2 sets; 10 broad looms; 21 sewing machines; steam; dye.

**Peabody.** A. T. & S. Fe. and C. R. I. & P. RRs.STATE SILK PLANT; L. A. Buck, mgr. (S) **Sabetha.** C. R. I. & P. RR.; St. J. & G. I. RR.

COLEMAN, W. C.; Woolen, Worsted, (K) Merino and Colton Hosiery; 9 knitting machines; steam; sell direct. (Buy wool yarns, 2/12, 2/22, 1/20, worsted 2/16, 1/16 dyed, coned and cotton, 1/10, 1/20, 1/24, 1/30 coned.)

**Topoka.** A. T. & S. Fe; C. R. I. & P.; L. T. & S.; M. P. and U. P. RRs.

TOPEKA WOOLEN MILL CO. See Oakland, (W) WESTERN WOOLEN CO.; \$50,000; J. F. (W) McAfee supt. and buyer; Cassimeres and Pants; 2 sets; 10 broad looms; steam; dye.

**Valley Falls.** A. T. & S. Fe RR.; K. C. Northwestern RR.; Union Pacific RR.PIAZZEK WOOLEN MILL; J. M. Piazzek; (W) Blankets; 1 set; 5 looms; steam and water; dye; sell direct. *Not running.***KENTUCKY.**

See map on page 94.

For explanation of abbreviations see page 66.

**Adairville.** H. 5. L. & N. RR.

McCRACKEN, R. W. &amp; J. D.; Red River (W) Mills; (P. O. address, Schley); R. W. McCracken, supt.; Blankets, Linseys, Jeans and Yarns; 1 set; 6 looms; water; dye; sell direct. (RR. station four miles away.)

**Carrollton.** F. 7. L. & N. RR.CARROLLTON WOOLEN MILLS; Kentucky (W) Jeans; 4 sets; 64 looms; steam; dye. *Idle.* (RR. station Worthville.)**Covington.** E. 8. L. & N. RR.; C. & O. RR.

ARGONAUT COTTON MILL CO.; \$75,000; (C) Wm. H. Alms, pres. and treas.; Jas. J. Hooker, vice-pres.; C. S. Wood, sec.; J. A. Statum, supt.; Warp and Twine; 4500 spindles; steam; Putnam, Hooker &amp; Co, Cincinnati, s. agt.; C. S. Wood, buyer.

COVINGTON WOOLEN MILLS CO.; 251 Pyke (W) St.; \$20,000; A. Montgomery, pres.; G. H. Montgomery, treas.; Blankets and Shirts; 2 sets; 10 broad looms; steam; dye. (To remove plant to Louisville, Ky.)

HAROLD KNITTING MILLS; Alex. Harold (K) prop.; J. A. Harold, agt.; H. D. Harold, supt.; All Wool Ladies', Childrens' and Men's Hosiery; 35 knitting machines; steam; dye; sell direct; Alex. Harold, buyer.

OVERMAN &amp; SCHRADER CORDAGE CO., (J) THE; \$300,000; Chas. Schrader, pres. and gen'l mgr.; E. W. Spreen, sec., treas.; Twines, Cords, Packings, Marlines and Tarred Cordage of all kinds; 2,000 spindles; steam; Charles Schrader, buyer; office in Cincinnati, Ohio.

RELIANCE TEXTILE &amp; DYE WORKS, (D &amp; F) THE; (Inc.); \$50,000; James J. Hooker, pres.; T. P. Talpey, agt. and buyer; Dyeing and Finishing of Cotton Piece Goods and Yarns; Putnam, Hooker &amp; Co., Cin., St. Louis and Chicago, s. agts.

**Danville.** G. S. C. N. O. & T. P. RR.

COGAR HEMP CO., THE GEO. (F1)

**Falmouth.** F. S. L. & N. RR.

WOODHEAD, JOSEPH; Flannels, Jeans, (W) Blankets and Yarn; 1 set; 5 looms; steam; dye; sell direct; Joseph Woodhead, buyer. (Buy 14 bleach cotton warp.)

**Forks of Elkhorn.** F. S. F. & C. RR.

STEDMAN, H.; Elkhorn Woolen Mills; (W) C. Beauchamp, supt.; Blankets, Jeans, Satinets, Yarns; 1 set; 7 looms; steam; dye; sell direct; H. Stedman, buyer. (Buy cotton warp, 14 to 16 black, for jeans and satinets.)

**Frankfort.** F. 7. L. & N. RR.; K. M. RR.

KENTUCKY RIVER MILLS; \$150,000; E. L. (F1) Samuel, pres.; R. W. McRery, treas.; Jas. Anderson, supt.; R. W. McRery, buyer; Binder Twine, Hemp and Flax Commercial Twines; water and steam; sell direct.

**Franklin.** H. 6. L. & N. RR.

FRANKLIN WOOLEN MILLS CO.; \$20,000; (W) Granville Roark, pres.; C. N. Roark, treas.; Harry Tatham, supt.; All-wool and Cotton Warp Blankets, Linsey and Yarns; 2 sets; 15 broad and 2 narrow looms; steam; dye; Harry Tatham, buyer. (Another set of cards and machinery expected to be put in later.)

**Grahamton.** G. 6. C. O. & S. W. RR.

GRAHAMTON MFG. CO.; \$150,000; John C. (C) Russell, pres.; A. M. Robinson, treas.; John Eham, supt.; Seamless Grain Bags; 3300 spindles; 75 looms; steam and water; Robinson-Hughes Co, Louisville, and R. McK Jones Co, St. Louis, s. agts.

**Henderson.** G. 5. C. O. & S. W. RR.; L. & N. RR.; L. St. L. & T. RR.

HENDERSON COTTON MILLS; \$500,000; (C) James E. Rankin, pres.; Paul J. Marrs, treas. and supt.; Brown Sheetings; 35,360 ring and 12,224 mule spindles; 1276 looms; steam; T. J. Shaw &amp; Co, R. McK Jones &amp; Co, St. Louis, Robinson-Hughes Co, Louisville, Ky, s. agts; Paul J. Marrs, buyer.

HENDERSON WOOLEN MILLS; \$100,000; P. (W) J. Marrs, pres.; Phil. M. Smith, treas. sec. and supt.; Kentucky Jeans, Unions and Cotton Worsteds; 1724 spindles; 2 sets; 64 jeans and 8 broad looms; steam; dye; sell direct; Phil M. Smith, buyer. (Buy yarn.)

**Lexington.** F. S. C. & O. RR.; L. & E. RR.; L. & N. RR.; Q. & C. RR.; S. R. Co. RR.

LOUGHRIDGE, W. J.; J. H. Yellman, supt.; (F1) Carded Hemp; 1 set; 1 backle; steam; Flint Eddy &amp; American Trading Co, N. Y. and A. D. Weld's Sons, Boston, s. agts.

NELSON, W. B.; Double and Single (F1) Dressed Hemp; Shorts and Tow.

PHOENIX WOOLEN MILLS; D. A. (W &amp; K) Loud &amp; co.; R. L. Combs, supt. and buyer; Hosiery, Jeans, Blankets, Yarns; 2 sets; 12 looms; 40 knitting machines; steam; dye; sell direct.

SCOTT, J. PERCY; Hemp. (F1)

**Louisville.** F. 7.ANCHOR MFG. Co. *Out of business.*

BEARGRASS WOOLEN MILLS; 529 W. (W) Main St.; \$50,000, C. B. Robinson, pres;

John C. Hughes, treas; Avery Robinson, supt.; Jno. C. Hughes, buyer; Knitting Yarns and Blankets; 1480 spindles; 2 sets; 8 looms; steam; dye; sell direct.

**FALLS CITY JEANS & WOOLEN CO.**; \$300. (W) 000; C. P. Moorman, pres.; R. L. Whitney, treas. and buyer; J. W. Hirst, supt.; Kentucky Jeans and Cassimeres; 11 sets; 204 narrow and 81 broad looms; steam; dye; sell direct.

**HOPE WORSTED MILLS**; \$100,000 (paid (W) in); Logan St. and Mason Ave.; Chas. F. Murphy, pres.; J. W. Stine, Jr., vice-pres and mgr; J. T. Moore, sec. and treas; Worsted Yarns; (English System); 6 combs; 7 sets; 5760 spindles; steam; Chas. F. Murphy & Co., Boston, s. agts.; J. W. Stine, Jr., buyer.

**LOUISVILLE COTTON MILLS CO.**; 1008 Goss (C) Ave.; \$300,000; Philip S. Tuley, pres, treas. and buyer; W. W. Cumcock, supt.; Cotton Warps and Hosiery Yarns; 1,440 ring and 4032 mule spindles; steam; dye; Waters-Garland Co., Louisville, s. agts.

**LOUISVILLE GIRTH & BLANKET MILLS**; (W) Chas. Semple, prop; Preston St. and Burnett Ave.; \$20,000; Otto Spies, supt.; Cotton, Hair and Jute Girths, Saddle Blankets, Rope, etc.; 2 sets; 350 spindles; 2 looms; steam; dye. (Buy cotton yarns, 3 and 6s on bobbins or cones only.)

**LOUISVILLE WOOLEN MILLS**; \$300,000; (W) J. W. Ainslie, pres; A. M. Robinson, treas; Geo. A. Robinson, gen. mgr. and buyer; Kentucky Doeskin Jeans; 12 sets; 364 looms; steam; dye; sell direct.

#### OHIO FALLS DYE & FINISHING WORKS.

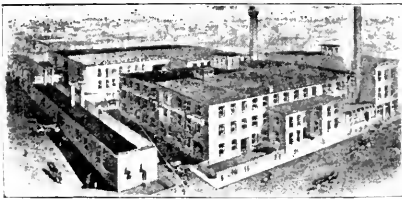

**OHIO FALLS DYE & FINISHING WORKS**; (D & F) \$50,000; John E. Norris, pres; E. Galatbi, sec. and treas; Wm. B. Nanson, gen. mgr; dye and finish Cotton Piece Goods; steam. [Make a speciality of dyeing and finishing cotton piece goods and guarantee first-class work. Southern mills find it advantageous to send their work here, saving in freight and time. Send communications to 717-731 East Madison St., Louisville, Ky.]

**MAYFIELD WOOLEN MILLS CLO. CO.**; (W) \$1,200,000; A. H. Duncan, pres.; J. D. Simpson, treas.; A. B. Hud peth, supt.; Cassimeres Made into General Line of Clothing; 12 sets; 88 broad looms; steam; dye; sell direct; J. D. Simpson, buye. (Main office and distributing point, St. Louis, Mo.)

**OLD KENTUCKY WOOLEN MILLS.** (See Mayfield Woolen Mills Clo. Co.)

**PERU BAGGING MILLS**; A. Lehman, in (J) charge; Jute Bagging; 2 sets; 17 looms. (Branch of mill at Peru, Ind. which see.)

**Madisonville.** G-5. L. & N. RR.

**PRITCHETT, H., & CO**; 2 sets roll cards; (W) steam.

**Mayfield.** H-3. C. O. & S. W. RR.

**MAYFIELD WOOLEN MILLS.** Removed to (W) Louisville and consolidated with Old Kentucky Woolen Mills.

**MAYFIELD KNITTING MILLS**; J. K. Rey. (K) holds, interested. *Proposed.*

**Maysville.** F-9. C. & O. RR.; L. & N. RR.

**JANUARY & WOOD CO.**; Maysville Cotton (C) Mills; \$200,000; A. M. J. Cochran, pres.; Robt. A. Cochran, treas; Carpet Chain, Stagings, Twines, Bating, Wick, Mop Yarn, Trot Line, Clothes Lines, Prow Lines, Rope; 5000 ring spindles; steam; dye; Putnam, Hooker & Co., Cincinnati, s. agts.

**Nicholasville.** G-8. C. N. O. & T. P. and R. N. I. & B. R.Rs.

**SPARKS, J. W. & Co.** Out of business. (F1)

**Paducah.** H-3. C. O. & S. RR; P. Tenn. & Ala. RR; St. L. A. & T. H. RR.

**ALDEN KNITTING MILLS**; \$40,000; R. B. (K) Phillips, pres; Ladies' Hose and Half Hose; 81 knitting machines; steam; dye.

**COHANKUS MFG. CO.**; \$150,000; P. E. (C) Hayes, (Pawtucket, R. I.) pres; C. R. Stearns, (Cincinnati) treas; F. P. Todd, agt. and buyer; Cotton Rope, Warps, Wicks, Mop Yarns, Twine, etc; 2600 ring and 2300 mule spindles; steam; sell direct and Putnam, Hooker & Co., s. agts.

**Phil.** G-7. RR. Station Embank C. N. O. & T. P. RR.

**GREEN RIVER WOOLEN MILLS**; F. P. (W) Combest, pres; J. B. Carson, treas; O. C. Russell, supt; Yarns, Flannels, Blankets, Jeans, Linsey; 1 set; 8 looms; steam; dye; sell direct.

**Schochoh.** H-5. RR. Station Adairville L. & N. RR.

**BROWNS, G. T.**; Jeans, Linseys and Knit. (W) ting Yarns; 1 set; 1 loom; water; dye; sell direct. *Mill idle.*

**Scottsville.** H-6. C. & N. RR.

**SETTLE, T. J.**; T. J. Settle, buyer; Jeans, (W) Linseys, Yarns, Blankets; 2 sets; 5 looms; steam; dye; sell direct.

## LOUISIANA.

No map.

For explanation of abbreviations see page 66.

**Clinton.** Y. & M. V. RR.

**CLINTON COTTON MILLS**; Yarns; 2,400 spindles; steam. *Not running.*

**Hammond.** Hl. Cent. RR.

**HAMMOND COTTON MILL CO.** Ltd; \$50,000; C. Frank E. Neelis, pres; L. I. Way, treas; J. B. Adams, sec; Osaburgs. *Proposed.*

**Monroe.** S. & L. I. M. & S. RR.

**OFACHITA COTTON MILLS**; \$155,000; Ernie (C) Millsaps (West Monroe), pres, and gen'l

mgr.; T. E. Flournoy, sec. and treas.; Sheetings; 5,000 spindles; 160 looms.

**New Iberia.** S. P. RR.

**NEW IBERIA COTTON MILL CO.** Ltd; (K) \$250,000; J. P. Suberelle, pres; A. B. Murray, treas; Wm. Magee, gen'l mgr; M. J. Walsh, supt; Fleece Lined and Balbriggan Underwear; 14 knitting machines; steam and electricity; dye; F. M. Farber & Co., N. Y., s. agts.

**New Orleans.** E. L. I. C. & L. & N.; N. O. F. J. & G. J.; N. O. & C.; N. O. & N.; N. O. & S.; S. P.; T. & F.; and Y. & M. V. RRs.

**ALDEN KNITTING MILLS;** \$10,000; A. W. (C) McLellan, pres.; Alden McLellan, sec. and treas.; Wm. H. McLellan, mgr; A. W. McLellan, buyer; Yarns; 2500 mule spindles; dye; (capacity 1000 lbs. per day); sell direct.

**GULF BAG CO.;** (Branch Bemis Bro. Bag (J) Co.); J. M. Bemis, pres.; R. J. Wood, mgr; and buyer; Burlap Bags; electricity; sell direct.

**KOHLMANN COTTON MILL & MFG. CO.;** (C) \$100,000; Louis Kohlman, pres.; E. Mayer, sec. and treas.; Wm. J. Magee, supt.; Cotton Hosiery Yarns, from 6-16; 2400 mule spindles; steam; sell direct and through agents. (Operating Scummes Cotton Mill).

**LANE MILLS OF NEW ORLEANS;** \$375,000; (C) J. Freyhan, pres.; S. Odenheimer, treas. and mgr.; Shirts, Sheatings, Drills,

Ducks, Osnaburgs, Ball Sewing Thread, Denims; 17,000 spindles; 368 looms; steam; dye; sell direct.

**MAGINNIS COTTON MILLS;** \$475,000; Frank (C) T. Howard, pres.; W. T. Maginnis, treas. and sec.; Elias Richards, supt.; Sheatings, Shirts, Drills, Osnaburgs, Canton Flannels, Batting; 40,752 spindles; 1216 looms; steam; Robinson-Hughes & Co., Louisville, Haines & Bishop, N. Y., Putnam Hooker & Co., Cinn. and J. H. Lane & Co., s. agts; also sell direct.

**Huston.** V. S. & P. RR.

**HUEY, S. C.;** Sheatings, Plaids, Cotton-ades; 5,000 lbs per day. *Proposed.*

**Shreveport.** K. C. P. & G. RR.

**HARGROVE COTTON MILL COMPANY;** \$100,000; L. C. Allen, pres; B. Holzman, treas.; Rosa Kelley, sec; 4 and 5-yd. Sheeting; 5,000 spindles; 150 looms. (Mill building completed; expect to install machinery soon and have plant in operation by fall.)

## MAINE.

See map on page 104.

For explanation of abbreviations see page 66.

**Abbott Village.** A-10. Ban. & A. RR.

**DILL MFG. CO., THE;** C. C. (W) Emerson (Bangor, Me) pres; F. H. Drummond (Bangor), treas; J. C. Dill, agt. and supt.; Cassimeres, Blankets, Satinets, Stocking Yarn; 3 sets; 20 looms; steam and water; dye; sell direct; J. C. Dill, buyer.

**Alfred.** G-7. P. & R. RR.

**SPRINGFIELD, C. W.;** C. O. Shattuck, (W) supt.; Bed Blankets; 3 sets; 14 looms; water and steam; sell direct.

**Auburn.** D.S. Maine Cen. RR.

**BARKER MILL;** (Little Androscoggin (C) Water Power Co); \$340,000; W. W. Bolster, pres; A. M. Pulsifer, treas; Wm. Hayes, agt; Fine Sheatings and Shirts, Cotton Yarns; 20s to 45s, Warps, Beams, Ball, Filling Cops; 10,768 ring and 11,360 mule spindles; 432 looms; water; sell direct; Wm. Hayes, buyer.

**Augusta.** D-10. M. C. RR.

**EDWARDS MFG. CO.;** \$1,100,000; Dexter N. (C) Richards, pres; Jacob Edwards (Boston), treas.; N. W. Cole, agt; M. M. Stone, supt.; Print Cloths, and Sheatings; 100,000 spindles; 2560 looms; water; Bliss, Fabyan & Co., s. agts.

**Bangor.** B-12. M. C. RR.

**BERLIN KNITTING CO.;** Underwear and (K) Sweaters; 10 knitting machines; electricity; sell direct. (Buy 2/20, 2/18, 2/16 wool and 4/15, 4/20 worsted yarn.)

**GOULD, O. L.;** Shoddy; 2 cards; 1 (W) picker; steam and water.

**Bath.** E-9. M. C. RR.

**STANDARD ROPE & TWINE CO.;** *Idle since 1895.*

**Biddeford.** G.S. B. & M. RR, E. & W. Divs.

**LACONIA CO.;** *Consolidated with Peppercell Mfg. Co, which see.*

**PEPPERELL MFG. CO.;** \$2,556,000; James (C) Longley, pres; P. Y. DeNormandie, treas; Robt. McArthur, agt; Geo. K. Gibbs and E. S. Donaldson, supts; Sheatings, Shirts, Hosiery, Cotton Flannels and Drills; 200,000 spindles; 6300 looms; Steam and water; Bliss, Fabyan & Co., s. agts; Robert McArthur, buyer.

**Bridgton.** E-7. B. & S. RR.

**FOREST MILLS CO.;** \$100,000; W. F. Perry, (W) pres; H. Clark, treas; M. D. Harris, supt;

Cheviots and Ladies' Dress Goods; 7 sets; 36 looms; water and steam; dye; Deering, Milliken & Co., N. Y., and Boston, s. agts.

**PONDCHERRY CO.;** \$84,600; S. M. Milliken, (W) pres; Horatio Clark (Portland), treas; M. D. Harris, supt. and buyer; Ladies' Wear, Cassimeres and Cheviots; 12 sets; 62 looms; steam and water; dye; Deering, Milliken & Co., N. Y., and Boston, s. agts.

**Brooksville.** D-12. Boat from Rockland on M. C. RR, B. & B. SS. Co. to Castine.

**WALKER, J. G.;** Blankets, Yarns, etc; 1 (W) set; 4 looms; water; dye.

**Brunswick.** E-9. M. C. RR.

**CABOT MFG. CO.;** \$800,000; J. L. Stackpole (C) (Boston), pres; M. U. Adams (Boston), treas; Russell W. Eaton, agent; Sheatings and Shirts; 34,096 ring and 34,816 mule spindles; 1672 looms; water; Eldredge, Lewis & Co., Boston and N. Y., s. agts.; M. U. Adams and R. W. Eaton, buyers.

**MICHAEL, JAS. W.;** Worsted and Cotton (K) Hosiery; 5 knitting machines; sell direct.

**Calais.** W. C. RR.

**ST. CROIX SHOE CO.;** Shoddy for mak- (W) ing Inner Soles.

**Camden.** D-11. Electric cars, 8m from Rockland on M. C. RR, B. & B. SS. Co.

**CAMDEN WOOLEN CO.;** \$150,000; J. H. (W) Montgomery, pres; W. P. Gould, treas; G. W. Taylor, supt. and buyer; Fancy Cassimeres and Dress Goods; 6 sets; 42 looms; water; dye; W. J. Battey & Co., 56 Worth St., N. Y., mgr. and s. agts.

**KNOX WOOLEN CO.;** \$146,000; B. C. Adams, (W) pres, and treas; C. W. Babb, supt; Excelsior Felts and Jackets and Woolen Specialties; 7 sets; 33 looms; steam and water; dye; Buckley, Dunton & Co., N. Y., and Edward H. Best & Co, Boston, s. agts; C. W. Babb, buyer.

**MEGENTCOOK WOOLEN CO.;** W. G. (W) Alden, pres, and treas; F. K. Allen, agt, supt. and buyer; Woolen Specialties; 4 sets; 24 looms; water; dye; sell direct; office, 68 Essex St., Boston, Mass.

**MT. BATTIE MFG. CO.;** \$144,000; E. Frank (W) Knowlton, pres; W. F. Bisbee, treas; Geo. G. Crane, supt.; Woolen Goods, mostly Cassimeres; 5 sets; 40 looms; water; dye; O. H. Hayes & Co., s. agts.; Geo. G. Crane, buyer.

**Caribou.** Not shown on map. Can. Pac. RR.

**CARIBOU WOOLEN MILL,** T. T. Crockett; (W. W. E. Crockett, supt.; Domestics and Yarns; 1 set; 4 looms; water and steam; dye.

**Castine.** C-12. M. C. RR.

**CASTINE LINE & TWINE CO;** Edward H. Carpenter, prop. and owner; (formerly J. W. Dresser); Cod and Mackerel Lines; steam; sells direct; buys 8 and 9 single warp on beams.

**Corinna.** B-11. M. C. RR.

**GREENWOOD, CHAS. A. & Co;** Cotton (W. Warp Cassimeres; 3 sets; 20 looms; water; dye.

**Dexter.** A-11. M. C. RR. See also No. Dexter.

**AMOS ABBOTT & Co;** Inc. \$150,000; J. (W. Abbott, pres; A. P. Abbott, treas. and agt.; G. W. Abbott, supt.; Men's and Ladies' Suitings and Melton Overcoatings; 5 sets; 50 broad and 2 narrow looms; steam and water; dye; sell direct, and O. H. Hayes & Co., and W. Sturberg, Schell & Co., N. Y., s. agts.; A. P. & G. W. Abbott, buyers. (Buy cotton warps single 8 and 12.)

**MORRISON WOOLEN CO;** J. L. Morrison, (W. supt. and buyer; Repellents, Homespun, and Skirtings; 6 sets; 45 looms; steam and water; dye; O. H. Hayes & Co., N. Y., s. agts. (Buy cotton warp, black and white, 24/28/30.)

**SCOTT, WALTER & Co;** (formerly Pe- (W. nobscott Woolen Co.); Walter Scott, agt.; P. S. Plouff, supt.; Meltons, Flannel Suiting and Overcoating; 7 sets; 48 looms; water and steam; dye; sell direct and Battelle, Hurd & Co., Boston and N. Y., s. agts.; P. S. Plouff, buyer.

**WASSOOKEAG WOOLEN CO;** \$40,000; Na. (W. than Daggett, pres; D. H. Midgrett, treas; W. L. Mobbett, supt.; Repellants; 4 sets; 34 looms; water and steam; dye; Fred'k Victor & Achelis, N. Y., s. agts.

**Dover.** A-11. M. C. RR. & Ban. & A. RR.

**BROWNS MILLS;** (American Woolen (W. Co.); Wm. M. Wood, (Boston), treas; S. O. Brown, resident agt.; Kerseys; 11 sets; 60 looms; water; dye; J. Clifford Woodhull, N. Y. s. agt.; H. J. Potter, (Boston), buyer.

**E. Madison.** B-10. M. C. RR.

**LAKESIDE WORSTED MILL;** See Skowhegan.

**E. Wilton.** C-8. M. C. RR.

**WALKER MILLS, THE;** \$50,000, Thomas (W. Walker, Jr, pres; Edward A. Hatch, treas; James Walker, supt.; Cloakings, Suitings and Cassimeres; 5 sets; 18 looms; water; dye; The Allen Lane Co, Boston and New York, s. agts; James Walker, buyer.

**Ellsworth.** C-13. M. C. RR, 30m. from Bangor.

**ELLSWORTH WOOLEN MILLS;** C. A. (W. Dews; (formerly G. L. Morrison); Knitting Yarns, Cassimeres, etc; Fine Blankets, Men's Wear and Dress Goods; 1 set, also roll card; 3 looms; water power; dye; sell direct; (buy cotton warps.)

**Fairfield.** C-10. M. C. RR.

**KENNEBEC MILLS (American Woolen (W. Co.); Wm. M. Wood, (Boston), treas; Louis A. Anderson, agt.; Cassimeres; 8 sets; 57 looms; water and steam; dye; J. Clifford Woodhull, N. Y., s. agt; H. J. Potter, (Boston), buyer.**

**Foxcroft.** A-11. M. C. RR and Ban. & A. RR.

**MAYO & SON;** Jas. Bathgate, supt; (W. Ladies' Dress Goods; 6 sets; 36 looms; water and steam; dye; Deering, Milliken & Co, N. Y. and Boston, s. agts.

**Freedom.** C-11. Stage at Belfast or Thordike on M. C. RR.

**LINN, WM., JR.;** Freedom Mills (form. (W. eryl A. A. Thompson); Carpet Weaving and Custom Work; 2 sets; 1 loom; water.

**Gardiner.** D-10. M. C. RR.

**COBBOSSEECONTEE WOOLEN CO;** Libbey (W. & Henderson; Howard Corning, supt; Dress Goods; 4 sets; 43 looms; water and steam; dye; H. J. Libby & Co., s. agts.; Howard Corning, buyer. (In Gardiner Woolen Co.'s plant.)

**GARDINER SHODDY MILLS;** Wm. Harvey (W. & Sons; (formerly W. C. Jack); Shoddy and Yarn Waste, carded; 7 sets; 2 pickers; water. (Also Readfield.)

**Guilford.** A-10. Ban. & A. RR.

**DEWS WOOLEN CO;** \$10,000; J. K. Edes, (W. pres; M. Hudson, treas; C. A. Dews, agt, supt and buyer; Cassimeres, Cloaking, Dress Goods and Fancy Checks; 1800 spindles; 4 sets; 25 looms; steam and water; dye; Converse, Stanton & Co., N. Y., s. agts.

**PISCATAQUIS WOOLEN CO;** \$120,000; Z. (W. L. Turner, pres; Henry Douglass, treas; J. R. Pollock, agt.; John Houston, supt. and buyer; Ladies' Dress Goods and Skirtings, Suitings and Men's Wear; 7 sets; 42 looms; steam and water; dye; H. J. Libby & Co., N. Y., s. agts.

**Harmony.** B-10. Stage 5m. from Hartland.

**BARTLETT, H. O.;** Bartlett Woolen Mill; (W. Woolen Yarn; 2 sets; 144 spindles; water; dye; sell direct.

**Hartland.** B-10. S. & M. RR.

**LINN WOOLEN CO.** (Sebasticock Woolen (W. Mills); \$225,000; H. C. Fuller, pres. and treas; Thos. A. Linn, sec; J. L. Eddie, supt; Henry C. Fuller, buyer; Dress Goods, Cloakings, Shawls and Rugs; 4626 mule spindles; 14 sets; 90 looms; water dye; H. J. Libby & Co, N. Y. s. agts.

**Houlton.** Not shown on map. Can. Pac. RR. and Ban. & A. RR.

**HOULTON WOOLEN MILLS;** 1. Bag. (W. & K. null, agt, supt. and buyer; Cassimeres, Flannels, Yarns, Satinets and Blankets; 2 sets; 6 looms; 3 knitting machines; steam; dye; sell direct.

**Kennebunk.** G-8 B. & M. RR, Western Div.

**LORD, R. W. & Co;** Chas. E. Manock, (C. supt.; Twines, Yarns; 4000 ring spindles; water; H. & G. W. Lord, Boston, s. agts. Mill at West Kennebunk, on East Div.

**Kezar Falls.** F-7. Stage 5m. from Cornish on M. C. RR.

**KEZAR FALLS WOOLEN MFG. CO;** (Inc.) (W. 1880; \$22,500; Geo. W. Towle, pres.; Allen Garner, treas. and agent; Wm. A. Garner, supt.; Dress Goods; 3 sets; 32 looms; steam and water; dye; Fred'k Army & Co., s. agts.; Allen Garner, buyer.

**Lee.** A-B. 12m. from Lincoln. M. Cent. RR.

**GIFFORD, J. T. & SOSS,** Satinets; Shirt. (W. ing, Cotton and Wool Blankets; 1 set; 2 looms; steam; dye.

**Lewiston.** D-9. M. C. RR and Im from Auburn, terminus of P. & R. F. RR.

**ANDROSCOGGIN MILLS;** \$1,000,000; Geo. (C. F. Fabyan, treas; Geo. W. Bean, agt; Sheetings, Shirts, Jeans, Seersucker and Grain Bags; 68,000 spindles; 1653 looms; water and steam; dye; Bliss, Fabyan & Co, N. Y. Boston and Phila, s. agts; Geo. F. Fabyan, buyer.

**AVON MFG. CO;** \$100,000; C. I. Barker, (C. pres; F. H. Packard, treas; A. D. Barker, agt; Quilts, Towelings, Bed Spreads, Scarfs, Table Covers; 60 broad and 75 narrow looms; water; bleachery; A. D. Smith, N. Y., s. agt.

**BATES MFG. CO;** \$1,200,000; Isaac T. (C. B. pres; Robert J. Edwards, treas; H. E. Pratt, agt.; J. G. Kelley, supt; Cotton

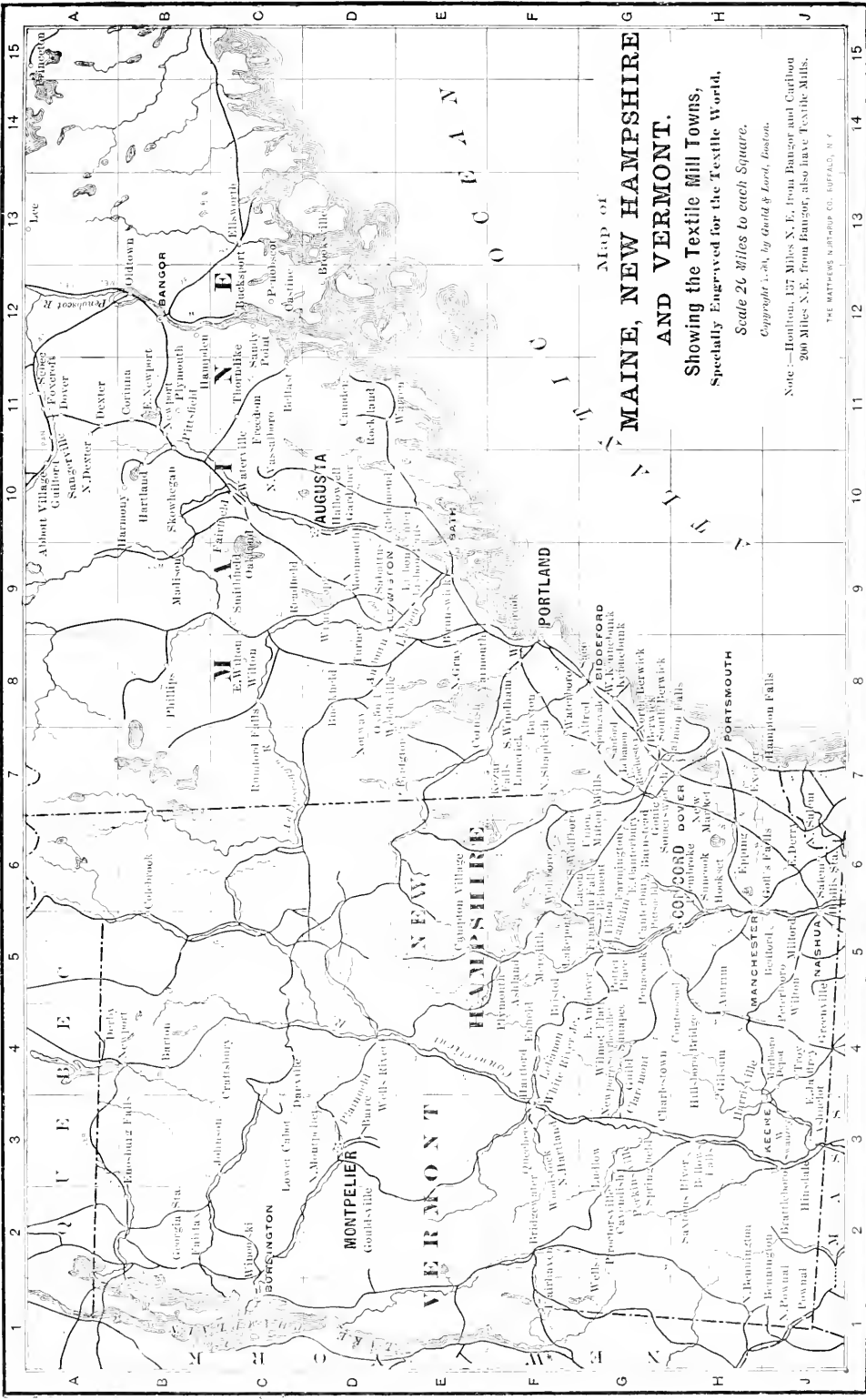

MAP OF

# MAINE, NEW HAMPSHIRE AND VERMONT.

Showing the Textile Mill Towns,  
Specially Engraved for the Textile World.

Scale 20 Miles to each Square.

Copyright 1908, by Gould & Lord, Boston.

Note.—Hathorn, 127 Miles N. E. from Bangor and Canaan  
200 Miles N.E. from Bangor, also have Textile Mills.

THE MATTHEW BURTNER CO., BUFFALO, N. Y.



- Goods; 57,664 ring and 4,320 mule spindles; 1875 looms; water; dye; Bliss, Fabyan & Co., Boston, N. Y., Chicago and Phila., s. agts.; H. L. Pratt, buyer. (Buy 33 filling ring spun and 50 and 60, cop.)
- COLUMBIA MILLS;** Thomas Kelly & Co. (W) (Boston), prop; W. H. Bower, agt. and supt; Blankets and Wrappers; 5 sets; 45 looms; water; dye; sell direct; 89 Chauncey St., Boston.
- CONTINENTAL MILLS;** \$1,500,000; Lyman (C) Nichols, pres; C. H. Wood (Boston), treas; H. B. Estes, agt; Brown Sheetings and Pillow Tubings, Grey Cotton Goods, Twills, Lawns, Sateens and various Plain Cloths; 90,000 spindles; 2250 looms; water and steam; C. H. Wood, 31 Bedford St, Boston, s. agt.
- COWAN WOOLEN CO;** \$75,000; Seth Milli. (W) ken, pres; H. M. Dingley, treas. and buyer; M. P. Hanley, supt; Cheviots and Cassimeres; 8 sets; 42 looms; water; dye; Deering, Milliken & Co., N. Y., s. agts.
- CUMBERLAND MILL;** Libbey & Dingley; (W) Repellents and Cotton Warp Suitings; 6 sets; 42 looms; water; dye; Deering, Milliken & Co., N. Y., s. agts.; W. S. Libbey, buyer.
- HILL MFG. Co;** \$1,000,000; Geo. F. Putnam, (C) pres; H. B. Richardson, treas; Wm. D. Pennell, agt; Sheetings, Shirtings, Twills; 54,208 spindles; 1318 looms; water; Amory, Browne & Co., N. Y., s. agts.
- LEWISTON BLEACHERY & DYE (D & B) WORKS;** \$300,000; Geo. Dexter (Boston), pres; John W. Danielson (Prov. R. I.), treas; James A. Walsh, agt.; Bleaching, Coloring and Finishing All Kinds of Cotton Goods; capacity 210 tons per week; water and steam.
- LIBBEY & DINGLEY CO;** Lincoln Mills; (C) \$300,000; H. M. Dingley, pres; W. S. Libbey, treas. and agt; Fine Yarns; 18,000 ring spindles; water; Catlin & Co., s. agts.; W. S. Libbey, buyer.
- Limerick.** F.7. Stage at Centre Waterboro, on P. & R. RR.
- LIMERICK MILLS;** Allen Garner (Kezar (W) Falls, Me.), leasee of plant; Ladies' Dress Goods and Suitings; 4 sets; 14 looms; 1160 spindles; water.
- Lisbon.** E.9. M. C. RR.
- FARWELL MILLS;** \$500,000; James B. Ayer, (C) pres; John W. Farwell (56 Summer St, Boston), treas; W. H. Miles, agt; Sheetings, Shirtings, etc.; 23,000 spindles; 558 looms; steam and water; Wheelwright, Eldredge & Co., Boston and N. Y., s. agts.
- Lisbon Centre.** E.9. Stage at Lisbon, M. C. RR.
- FARNSWORTH CO;** \$50,000; S. M. Milli. (W) ken, pres; D. W. Farnsworth treas; C. A. Julia, agt. and supt; Flannels and Dress Goods; 9 sets; 60 looms; water and steam; dye; Deering, Milliken & Co., N. Y., s. agts.; C. A. Julia, buyer.
- Lisbon Falls.** E.9. M. C. RR.
- WORUMBO MFG. Co;** \$500,000; J. W. (W) Danielson pres; G. C. Moses, (Bath, Me.), treas; F. Gutmann (Lewiston, Me.), agt; Walter U. Gutmann, supt; Beavers, Chinchillas, Floceomies, Kerseys, Cloakings, Cover Cloths, etc.; 23 sets; 107 looms; 4 boilers; 4 water wheels; dye; Deering, Milliken & Co., N. Y., s. agts; F. Gutmann, buyer.
- Madison.** B.9. Somerset RR. See also E. Madison.
- INDIAN SPRING WOOLEN CO;** \$100,000; A. (W) F. Libby, pres; D. F. Corser, treas; Robt. G. Henderson, agt. and supt; Cassimeres, and Cheviots; 7 sets; 44 looms; water; dye; H. J. Libby & Co. 55 & 57 White St, N. Y., s. agts.; R. G. Henderson, buyer.
- MADISON WOOLEN Co;** \$200,000; S. M. (W) Milliken, pres; A. R. Small, treas; Thos. P. Curtis, agt; M. J. McGuirk, supt. and buyer; Venetians, Kerseys, Sackings and Broadcloths; 18 sets; 84 looms; water; dye; Deering, Milliken & Co., N. Y., s. agts.
- Newport.** B.11. M. C. RR.
- NEWPORT WOOLEN Co;** \$50,000; Gordon (W) Dobson (Pittsfield, Me.), pres; H. C. Fuller (Hartland, Me.), treas; Ellis Jones, supt; Fancy Cassimeres, Cheviots, Fine Suitings and Overcoatings; 7 sets; 32 looms; water; dye; Greeley, Cushman & Record and Hardt von Bernuth & Co., s. agts. Messrs. Fuller and Jones, buyers.
- No. Berwick.** G.7. B. & M. RR.
- No. BERWICK CO;** \$80,000; M. R. Hobbs, (W) pres; W. B. Tobey, treas. supt. and agt; Flannel and Dress Goods; 8 sets; 42 looms; water and steam; dye; sell direct and Deering, Milliken & Co., N. Y., s. agts. W. B. Tobey, buyer.
- No. Dexter.** A.11. See Guilford.
- North Gray.** E.8. M. C. RR.
- NORTH GRAY WOOLEN MILL;** T. J. Shee (W) han; Shirtings and Dress Goods; 1 set; 15 looms; water; Converse, Stanton & Co., N. Y., s. agts.
- No. Monmouth.** D.9. 6 miles from Monmouth. M. C. RR.
- ANNABESSACOOK MILLS.** (Purchased A. R. King's mill.)
- ANNABESSACOOK MILLS;** \$50,000; (for. (W) merly M. C. McIlroy); James E. McIlroy, pres.; R. C. McIlroy, treas.; J. H. McIlroy, agt. and gen'l mgr.; Bed Blankets; 5 sets; 38 looms; water and steam; dye; Converse, Stanton & Co., N. Y., s. agts.; John H. McIlroy, buyer. (Buy 14/1 cotton warp.)
- No. Shapleigh.** F.7. Stage 5m from Springvale on P. & R. RR, and RR. at E. Wakefield, N. H.
- HARGRAVES WOOLEN MILL;** E. Har (W) graves, prop; F. H. Hargraves, agt; Chas. W. Auel, supt; Dress Goods and Cassimeres; 6 sets; 2200 ring spindles; 35 looms; water; dye; Aberg & Rusch, N. Y., s. agts. Freight office, East Wakefield, N. H.
- No. Vassalboro.** C.10. Stage from Waterville (6 m) on M. C. RR.
- PEACE HERBERT;** All Wool Shoddy (W) and Extracts; 2 sets; 2 pickers; water.
- VASSALBORO WOOLEN MILLS;** (Ameri. (W) can Woolen Co.) W. M. Wood, Boston, treas; F. H. Jealous, agt; Fancy Woolens; 25 sets; 106 looms; water and steam; dye; J. Clifford Woodhull, N. Y., s. agt; H. J. Potter, (Boston), buyer.
- Oakland.** C.10. June. of Somerset and M. C. RRs.
- CASCADE WOOLEN MILL;** \$125,000; J. B. (W) Mayo, pres; Thos. P. Curtis (Boston), treas; Geo. H. Wingear, supt; Dress Goods; 10 sets; 60 looms; water; dye; Deering, Milliken & Co., s. agts.
- OAKLAND WOOLEN Co;** \$100,000; W. M. (W) Ayer (Oakland), pres.; W. T. Haines (Waterville), treas.; Geo. W. Taylor, agt.; Woolen Men's Wear, Medium and Cheap Goods; 3 sets; 44 looms; water and electric; dye; Ethan Allen, N. Y., s. agt. (Projected. Expect to be in operation fall, 1902.)
- Old Town.** B.12. Ban. & A. and M. C. RRs.
- OLD TOWN WOOLEN CO;** \$150,000; (Inc. (W) 1877); Melvin S. Holway, pres; Herbert Gray, treas; F. W. Phelps, supt; Men's Wear; 9 sets; 64 looms; water and steam; dye; Greeley, Cushman & Record, Boston, s. agts.; Frank W. Phelps, buyer.
- OUNEGAN WOOLEN CO;** \$60,000; Gordon (W) Dobson, pres.; Thos. W. Beattie, supt. and buyer; A. H. Brown, treas; Cassimeres, Cheviots and Dress Goods; 4 sets; 32 looms; water; dye; W. Starnsberg, Schell & Co., N. Y., s. agts.

**Oxford.** D-S. G. T. RR.

ROBINSON MFG. CO; \$100,000; J. B. Rob- (W) inson, pres. and agt.; F. A. Libby, treas.; Dress Goods, Broadcloths, Sackings, etc; 10 sets; 67 broad looms; water; dye; H. J. Libby & Co, N. Y., s. agts.

**Paris.** (RR. Station So. Paris.) D-S. (Not shown on map.) Grand Truck.

LINEN MFG. CO., THE; (office Room 33, (F) 70 State St., Boston, Mass.); C. K. Corsant (Cambridge) pres. John F. Wood, (Boston), treas.; B. C. Mudge, sec.; To manufacture from flax. (Proposed.)

**Penobscot.** C-12. Stage 14m. from Bucksport on M. C. RR.

CONDON, A. C. & Co.; Mittens; 60 knit- (K) ting machines. (Knit for O. L. Bailey & Co., Boston, Mass.) (P. O. address, So. Penobscot.)

CREAMER, W. J.; Wool and Worsted Mit- (K) tens; 50 knitting machines.

**Phillips.** B-S. Sandy River RR.

PHILLIPS WOOLEN CO, THE; \$10,000; E. (W) J. Ross, pres; Geo. B. Sedgely, treas; Yarn, Bed Blankets, Satinets, and All Wool Cloths; 1 set; 1 loom; water; dye; sell direct; H. J. Hesecock, buyer.

**Pittsfield.** B-II. M. C. RR.

DOBSON, ROBT. & Co; Pioneer Woolen (W) Mills; Wm. Dobson, agt.; S. R. Haines, supt; Fancy Cassimeres and Scotch Cheviots, Men's Wear generally; 12 sets; 80 looms; water and steam; dye; Greeley, Cushman & Record, N. Y., Boston and Chicago, s. agts; Gordon Dobson, buyer.

RIVERSIDE WOOLEN Co. \$40,000; F. R. (W) Smith, pres; T. E. B. Knowles, treas; Ernest Maxfield, supt; Dress Goods, Cassimeres and Cheviots; 4 sets; 28 broad and 1 narrow loom; water and steam; dye; Greeley, Cushman & Record, Boston, s. agts.

WAVERLEY WOOLEN CO; \$160,000; (Inc. (W) 1892); A. P. McMaster, pres; Gordon Dobson, treas; C. L. Staples, supt; Fine All-Wool Men's Wear Goods; 9 sets; 50 looms; water; dye; Greeley, Cushman & Record, Chicago, N. Y. and Boston, s. agts.; Gordon Dobson and Charles L. Staples, buyer.

**Plymouth.** B-II. (4 m. from Newport.)

ROBINSON & LAMB; Plymouth Carding (W) Mill; Satinets, Blankets and Yarns; 3 sets; 2 looms; steam and water; dye; (freight address East Newport.)

**Princeton.** A-15. St. C. & P. RR.

PEABODY, S. L.; Stocking Yarns; 1 set; (W) water.

**Readfield.** D-9. M. C. RR.

READFIELD WOOLEN MILLS; Wm. Har- (W) vey & Son; Cheviots and Dress Goods; 2 sets; 800 spindles; 12 looms; water; dye; Oelbermann, Dommerich & Co., s. agts. (Also Gardiner.)

**Richmond.** E-10. M. C. RR. and Kennebec Steamboat Co. from Boston.

KENNEBEC SPINNING MILLS (formerly (C) Richmond Mills); A. B. Sanford (Boston) pres. and gen'l mgr.; Noble Maxwell, treas.; Henry Howe, supt.; High Grade Egyptian and Combed Sea Island Yarns, 4 to 36s, 2, 3, 4, 5, 6, 7 and 8 ply; 5000 spindles; steam; A. B. Sanford, 67 Chauncy St., Boston, s. agt.

**Rumford Falls.** C-S. P. & R. F. RR.

RUMFORD FALLS WOOLEN MILLS; \$30,000; (W) Geo. B. Bisher, treas.; John Crowe, agt.; Paper Makers' Felts; 1 set; 9 looms; electric power; dye; sell direct and Chas. D. Brown and Train, Smith & Co., Boston, s. agts.

**Sabatius.** D-9. M. C. RR.

WEBSTER WOOLEN CO; \$100,000; John S. (W) Bleakie, pres; Henry S. Bunton, treas;

Robt. Bleakie, (Hyde Park, Mass.) gen. mgr; Wm. J. Bleakie and J. Frank Vose, supts; Fancy Cassimeres; 13 sets; 5600 mule spindles; 80 looms; steam and water; dye; Oelbermann, Dommerich & Co., N. Y., Cooley, Turnbull & Co. and Whitman & Phelps, s. agts; Robert Bleakie, buyer.

**Saco.** G-S. B. & M. RR. W. and E. Divs.

YORK MFG. CO; \$900,000; James Longley, (C) pres; F. C. McDuffie, (Boston) treas; Elmer E. Page, agt; Horace S. Hall, supt; Colored Cotton Goods; 50,000 spindles; 1800 looms; steam and water; dye; Smith, Hogg & Co., s. agts.

**Sandy Point.** C-12. M. C. RR.

BLACK, M. MRS; Woolen Mittens; 10 (K) knitting machines; hand power; O. L. Bailey & Co., s. agts. (RR. station Bucksport.)

**Sanford.** G-7. Electric cars from Springvale, P. & R. RR.; also from Kennebank on B. & M. RR.

GOODALL WORSTED CO.; \$500,000; (Paid (W) in \$348,400.) Geo. B. Goodall, pres.; L. B. Goodall, treas.; Wm. Batchelder Jr., supt, Spinning; J. Hollinrake, Weaving; Mohair, Alpaca and Worsted Yarns, Dress Goods, Serge Linings, etc.; 16 combs (English system); 6 sets worsted cards; 130 wide and 78 narrow looms; 36500 spindles; steam and electric; dye; sell direct and Abegg & Rusch and Fleitmann & Co., N. Y., s. agts.; both supts., buyers. (Buy worsted yarns up to 60s.) (Building a new mill of 321 looms.)

**MAINE ALPACA CO.** (See Springvale.)

SANFORD MILLS; \$750,000; E. M. Goodall, (W) pres. and agt; Frank Hopewell, (Boston), treas; Carriage Robes, Horse Blankets, Mohair, Car and Upholstery Plushes; 4 combs, 16 sets; 200 looms; 12,000 Worsted spindles; steam and water; dye; L. C. Chase & Co, 129 Washington St, Boston, s. agts.

**Saugerville.** A-II. Ban. & A. RR.

CAMPBELL MFG. CO; \$100,000; D. R. (W) Campbell pres; D. O. Campbell, treas; A. O. Campbell gen'l mgr; Ladies' Dress Goods, Cloakings and Suitings; 4 sets, 60-in; 36 looms; broad fancy; water and steam; dye; Fred'k Almy & Co., N. Y., s. agts.; A. O. Campbell, buyer.

CARLETON MILLS CO; \$40,000; (Inc. 1881); (W) Moses Carr, pres; A. L. Carr, treas; N. J. Lamb, supt. and buyer; Ladies' Dress Goods and Suitings; 3 sets; 21 looms; steam and water; dye; Converse, Stanton & Co, N. Y. and Boston, s. agts.

SANGERVILLE WOOLEN CO; Moses Carr, (W) pres; F. H. Carr, treas. and mgr.; Cassimeres, Overcoatings, Cloakings and Ladies' Suitings; 3 sets; 1600 ring spindles; 32 looms; steam and water; dye; Converse, Stanton & Co, N. Y. and Boston, s. agts; Messrs. Carr and Gordon, buyers.

**Sebecton.** A-II. Ban. & A. RR.

SEBECTON WOOLEN MILLS; 3 sets; 22 looms; (W) water; *Middle; for rent.*

**Showhegan.** B-10. M. C. RR.

ANDERSON MILLS; American Woolen (W) Co, Wm. M. Wood, (Boston), treas; Frank H. Carpenter, agt; W. F. Shaw, supt; Cassimeres, Cheviots, Worsteds, etc; 12 sets; 52 looms; water; dye; J. Clifford Woodhull, N. Y., s. agt; H. J. Potter, (Boston), buyer.

LAKE-SIDE WORSTED MILLS; (Merston (W) Woolen Co. lessees); Fancy Worsted Suitings; 32 looms; steam and water; finish. Mill at E. Madison.

MARSTON WOOLEN CO; \$20,000; (paid in) (W) Thomas A. Marston, pres; Herbert Wentworth, sec; R. T. Patten, treas; Edwin Gledhill, business mgr; Worsted Goods; 28 looms; water; Henry W. T. Mull & Co, s. agts.

- ORIENTAL RUG WORKS;** L. L. Morrison; (**J**) Rugs from Old Syrian, Tapestry and Velvet Carpets; 10 looms; electric power; sell direct. (Also branch at Barre, Mass.)
- Smithfield.** C-9. (8 m. from Oakland.)
- HILL, MRS. G. L.** Jas. Harlow, mgr.; (**W**) Carding mill.
- WYMAN, L. J.** Waste; Garnetting, (**W**) etc; 1 picker; 2 cards; water.
- So. Berwick.** G-7. B. & M. RR, E. Div.
- CARPENTER, Wm. D.** Blankets; 2 sets; 5 (**W**) looms; water and steam.
- NEWICHAWANICK CO;** \$150,000; Matilda (**W**) Burleigh, pres; Ephraim Hodgdon, treas; John Drury, supt; Blankets, Slasher and Clearer Cloths, and Horse Goods; 3400 mule spindles; 12 sets; 52 broad looms; water and steam; dye; Thos. Kelly & Co, Boston, N. Y. and Chicago, s. agts.; E. Hodgdon, buyer.
- South Windham.** F. S. M. C. RR.
- ROBINSON MILLS;** \$100,000; J. L. Robin (**W**) son, pres; C. A. Robinson, treas; Repellents, Dress Goods; 5 sets; 46 looms; water and steam; dye; Deering, Milliken & Co, N. Y. s. agts.
- Springvale.** G-7. P. & R. RR.
- MAINE ALPACA CO;** \$121,500 (paid in); (**W**) Geo. B. Goodall, pres; L. B. Goodall, treas; J. Hollinrake, supt; Serge Linings; 2,800 spindles; (English system); 5 combs; 40 wide and 234 narrow looms; steam and water; Abegg & Rusch and Fleitmann & Co, s. agts.; J. Hollinrake, buyer.
- OLDEN, CHAS. H;** Flocks, Shoddy and (**W**) Waste.
- MOUSAM RIVER MILL;** (H. H. Groves (**W**) and C. J. Boeocock); H. H. Groves, supt.; Union Goods; 2 sets; 14 looms; water and steam; dye. (Operating Springvale Woolen Co.'s mill.)
- Turner.** D-8. Stage 6m at Buckfield on P. & R. F. RR.
- FALKNER, F. T.** Turner Woolen Mills; (**W**) Flannels and Blankets; 4 sets; 24 broad looms; steam and water; sell direct and Thos. Kelly & Co., 89 Chauncy St., Boston, s. agts.
- Warren.** D-11. M. C. RR.
- GEORGE'S RIVER MILLS;** \$100,000; Chas. (**W**) W. Parker, pres; E. A. Hatch, treas; Geo. W. Walker, supt.; Chevots, Overcoatings and Dress Goods; 7 sets; 30 looms; water, steam and electricity; dye; Allen Lane Co, N. Y. and Boston, s. agts.; Geo. W. Walker, buyer.
- Waterford.** D-7. Nearest RR. station, Norway, M. C. R. R.
- HAMLIN, W. K.;** Wool Rolls and Bat- (**W**) ting; 1 set; water.
- Waterville.** C-10. M. C. RR.
- CHASE WOOLEN CO.;** Edward and (**W**) Frank Chase; 2 sets machinery. (To erect a new building and repair an old one in the spring.)
- LOCKWOOD CO;** \$1,800,000; Jos. H. McMul- (**C**) lan, pres; J. W. Danielson (Providence), treas; S. I. Abbott, agt; W. H. K. Abbott, supt; Sheetings and Shirtings; 36 to 108" wide; 62,520 ring and 20,800 mule spindles; 2173 looms; water; Deering, Milliken & Co., N. Y. and Boston, s. agts.; J. W. Danielson and S. I. Abbott, buyers.
- RIVERVIEW WORSTED MILLS;** \$100,000; (**W**) F. C. Thayer, pres; Thos. Sampson, treas; G. W. Overend, agt; Fine Worsted Goods for Men's Wear; 60 looms; electricity; dye. (Buy yarn.)
- Westbrook.** E-8. P. & R. RR. Electric cars from Portland.
- DANA WARP MILLS;** \$115,500 (paid in); (**C**) L. M. Cousens, pres.; W. K. Dana, treas.; Philip Dana, supt.; Cotton Yarns from 5 to 50 and Grain Bags; 22,000 ring spindles; 44 bag looms; water and electricity; dye; W. K. Dana, buyer.
- HASKELL SILK CO;** \$150,000; W. W. Poole, (**S**) pres; Lemuel Lane, treas; E. J. Haskell, supt; Dress Silks; 5000 spindles; 200 looms; steam and water; dye; sell direct; office, 70 Green St, N. Y.
- West Buxton.** F-8. In Buxton, stage at Saco River 4 m on P. & R. RR.
- SACO RIVER WOOLEN MILLS;** F. H. (**W**) Hargraves, prop.; Women's Wear; 4 sets; 25 looms; water; dye; Fred'k Victor & Achelis, s. agts.
- MARTIN & MARBLE;** West Buxton Mill; (**W**) Fancy Cassimeres; 2 sets; 10 looms; water; dye.
- Wilton.** C-8. M. C. RR.
- WILTON WOOLEN MILLS;** F. J. Good- (**W**) speed, prop; F. O. Goodspeed, supt; Cashmerettes, ; 6 sets; 1744 spindles; 56 broad looms; steam and water; dye; Battelle, Hurd & Co., Boston, s. agts.; F. S. Goodspeed, buyer.
- Winthrop.** D-9. M. C. RR.
- WINTHROP MILLS Co.;** \$150,000; (**C** & **W**) Amasa Clarke, (Boston,) treas; Ronald C. McElroy, agt; Jas. E. McElroy, supt; Blankets and Cotton Waprs; 11 sets; 4500 spindles; 82 looms; water; Cabot, Jones & Kelly, N. Y. s. agts.
- Yarmouth.** E-9. G. T. RR.
- ROYAL RIVER MFG. CO;** L. L. Shaw & Co; (**C**) \$30,000; M. J. Madsen, pres; L. L. Shaw, treas. and agt; Seamless Grain Bags, Warp Yarn and Twines; 2400 spinning and 580 twisting spindles; 40 bag looms; water; sell direct; L. L. Shaw, buyer.

## MARYLAND.

See map on page 82.

For explanation of abbreviations see page 66.

- Alberton.** B-8. B. & O. RR.
- GARY, J. S., & SONS;** Alberton Cotton (**C**) Mills; Drills, Duck, Osnaburgs, Denims, Twills, Warps, Awning Stripes, Etc.; 14, 000 spindles; 470 looms; steam and water; sell direct, and 106 W. German St., Balto.
- Baldwin.** B-8. See Bank.
- Baltimore.** B-8. B. & A. S. L.; B. & E. S.; B. & L.; N. C.; P. W. & B. and W. Md. RRs.
- EGAN, K., & Co.;** Baltimore Waste Co.; (**C**) 301 East Falls Ave; M. J. Morris, pres; K. F. X. Egan, treas; C. E. Egan, mgr; Cotton and Wool Waste, Laps and Bats; 12 cards; 17 waste machines; steam. (Also Brooklyn, N. Y.)
- DOMESTIC HOSIERY MILL;** \$25,000; A. M. (**K**) Bowling, pres.; Wm. F. Bowling, treas; Cotton Hose and Half Hose; 115 knitting machines; steam; sell direct.
- GREEN, A. & Co.;** 7 West German St.; (**C**) Warps, Twine, Wicks, Bats; 3000 spindles.
- JOHNSON, J. S. Co.;** 121 South St.; \$60,000; (**C**) J. S. Johnson, pres.; J. H. Chase, treas.; Seine Twine and Nets; 3 twisters; 7 looms; 4 braiders; 1 balling and 1 hanking machine; J. B. Casey, vice-pres., buyer. (Buy 8/2 ply for wrapping in Balls, Cones and Tubes, 8/4, 8/5, 8/6, 8/7, 8/8 ply cotton sail twine.)
- MARCEY, M. H., & Bro.;** 115 Worth St., (**C**) New York. (See Walpole, Mass.)

- MARYLAND BLEACH & DYE WORKS;** (**B&D**) 2805-2809 Hudson St.; Eugene Fisher, prop.; Bleaching and Dyeing (capacity 5000 lbs. per day); steam.
- MARYLAND WOOLEN CO.;** N. W. Steele, (**W**) mgr.; Heavy Cheap Kerseys, chief product; 8 sets; 40 looms.
- MT. VERNON CO.** (U. S. Duck Co.); office, (**C**) cor. Lombard and Cheapside Sts.; C. W. Wood, mgr.; Sail, Duck, Seine Twine, Bags, Rope, Yarn; 55,000 spindles; 700 looms; steam and water. Mills at Mt. Vernon, Phoenix and Woodberry. See Mt. Vernon Woodberry Co.
- NATIONAL SILK MILLS;** M. C. Migel & Co.; (**S**) Branch Mill; 100 looms. (See also Astoria, N. Y.)
- OAKLAND MFG. CO.;** 307 West German (**W**) St.; \$200,000; Henry A. Parr, pres.; Herbert Hooper, treas.; M. Glennon, supt.; Herbert Hooper, buyer; Wool Kersey and Cassimeres; 8 sets; 41 looms; water and steam; dye; sell direct.
- SCHULTZ & BRO.;** 215 West German (**W & J**) St.; Rag and Jute Carpets; 30 looms; sell direct; both buyers.
- MT. VERNON-WOODBERRY COTTON DUCK (C**) Co.; \$23,500,000; S. Davies Warfield, chairman of Board; the mills in this combination are: Mt. Vernon Co.'s 4 mills, Woodbury Mfg. Co.'s 5 mills; Laurel Mills, Laurel, Md.; Columbia Mills, Columbia, S. C.; Greenwoods Co., New Hartford, Conn.; Tallassee Falls Mfg. Co., Tallassee, Ala.
- U. S. COTTON DUCK CO.;** (combined com. (**C**) pany); Jas. E. Hooper, pres.; J. Spencer Turner, vice-pres.; Chas. K. Oliver, treas.; D. Carroll, sec.; S. Davies Warfield, chairman; Catlin & Co., N. Y. and Boston, Wellington, Sears & Co., N. Y. and Boston, and J. Spencer Turner Co., N. Y., Chicago and St. Louis, s. agts. This is the merger company controlling the Mt. Vernon-Woodbury Cotton Duck Co., and the product of others in the combination, sold through same agents.
- WOODBERRY MFG. CO.** (Mt. Vernon-Wood-**C**) berty Cotton Duck Co.); W. E. Hooper, mgr.; Cotton Duck, Twines, Ropes, Wicks and Yarn; about 35,000 spindles; 433 looms; steam. Have five mills. Clipper, Meadow, Park, Woodberry, at Balto; Washington at Mt. Washington.
- Bank.** B. S. B. & O. RR.
- BALDWIN MFG. CO.;** Thomas Carr, (**W**) (Phil.) and others; Tapestry Goods; 24 looms. (Buy 2/30 to 2/20 warps, 12/3 to 12/2 slack reel).
- GAMBRILL, M. & Co.** See *Haere De Grace*.
- Bay View.** (Cecil County.) B. S. B. & O. RR.
- TURNER, DANIEL;** Providence Woolen (**W**) Mills; Hugh Turner, supt; Woolens; 3 cards; 6 narrow and 2 broad looms; water; dye; sell direct.
- Brooklandville.** B. S. N. C. RR.
- ROCKLAND BLEACH & DYE WORKS (B&D**) Co.; \$50,000; Robt. H. Wright, pres. treas. and buyer; Bleach White Goods; steam and water; capacity, 36 tons per week. (RR. station, Rockland).
- Brunswick.** B. 7. B. & O. RR.
- JONES, KNITTING CO., LEWIS;** (branch (**K**) mill); Finishing Ladies' Knit Underwear; 50 sewing and finishing machines. (See also Winchester, Va.)
- Cumberland.** B. 5. B. & O. RR.; C. & Penn. RR.; G. C. & C. RR.; W. Va. Cent. & Pitt. RR.
- FOSTER, T., & SON;** Dyers. (**D**)
- KLOTS THROWING CO.;** (Scranton). (**S**) Branch Mill.
- Dickeyville.** B. S. (About 1 mile from Baltimore.)
- ASHLAND MFG. CO.;** \$210,000; W. A. (**W & C**) Dickey, pres. and treas.; Duck, Wool Kerseys and Overcoatings; 2900 ring and 6228 mule spindles; 20 sets; 105 looms; 29 cotton looms; steam and water; dye; W. J. Dickey & Sons, s. agts; W. A. Dickey, buyer.
- Dry Branch.** B. S. N. C. RR.
- SCHILLING, HENRY CO.** *Out of business.*
- Elkton.** B. 9. P. W. & B. RR.
- DEIBERT & WILSON;** Turkey Red Dam- (**C**) ask and Plaid Table Cloths; 90 ring spindles; 20 looms; steam; dye; Whitman & Phelps s. agts.; W. S. Deibert, buyer.
- Ellicott City.** B. 8. B. & O. RR.
- PATAPSCO ELECTRIC & MFG. CO.;** \$100,000; (**C**) Geo. W. Harris, pres.; V. G. Bloede, treas.; Propose using "Gray's Mill" property.
- Franklinville.** B. S. B. & O. RR.
- MT. VERNON-WOODBERRY COTTON DUCK (C**) Co.; Franklinville Duck Mills; Duck; 3500 spindles; 37 looms; water. See Baltimore.
- Frederick City.** B. 7. B. & O. RR.; P. R. RR.
- UNION MFG. CO.;** \$50,000; David Lowen- (**K**) stein, pres.; Geo. H. Zimmerman, treas.; John L. Johnson, supt; Hosiery; 300 knitting machines; steam; dye; sell direct and John M. Given, 109 Ninth St., Pittsburg, and 258 Church St., N. Y.; David Lowenstein, 18 S. Eutaw St., Balto., s. agts; Geo. H. Zimmerman, buyer. (Buy 8s to 60s cotton yarn.)
- Hagerstown.** B. 7. B. & O. RR.; C. V. RR.; N. & W. RR.; W. M. RR.
- BLUE RIDGE KNITTING CO.;** Jacob Roess. (**K**) ner, pres.; S. H. Weihenmayer; treas, agt., supt. and buyer; Cotton Seamless Hosiery; 125 knitting machines; steam; dye; D. L. Crowell, N. Y., s. agt.
- COLLINGS & NOLAN CO.;** Maryland Silk (**S**) Mill; Destroyed by fire, May, 1901; not rebuilt. (See Paterson, N. J.)
- ROULETTE, J. C. & CO.;** props. of R. A. (**K**) Knitting Mills; Ladies' Jersey Ribbed Underwear; 100 knitting machines; steam; sell direct; J. C. Roulette, buyer. (Buy 8s to 24s single and 50 two ends yarn.)
- WINDSOR KNITTING MILLS;** J. I. Bitner, (**K**) treas; H. J. Crosson, supt. and buyer; Men's Cotton Hosiery; 130 knitting machines; steam; sell direct and L. J. Riggin, N. Y., s. agt. (Use yarns, 8s to 60s.)
- Haere De Grace.** B. S. B. & O. RR.; Phila, W. & Balto. RR.
- GAMBRILL, M.;** Gambrill & Melville Mills; (**C**) Robt. Gambrill, supt. and buyer; Damask, Turkey Red; 225 looms; steam; dye; sell direct and Wm. Burgess & Co., s. agts. (Buy 20 Warps, 10 and 16 skeins.)
- Hughesville.** C. S. W. & P. RR. See Baltimore.
- Hchester.** B. S. B. & O. RR.
- THISTLE MILLS CO.;** \$120,000; S. F. (**C & S**) Patterson, pres. and treas.; A. B. Johnston sec; R. P. Deal, supt.; Demins, Domets, Crashes, Novelties and Broad Silks; 7384 spindles; 212 cotton and 188 silk looms; steam and water; dye; A. D. Smith, N. Y., Wm. Iselin & Co, N. Y., Jas. W. Cook & Co., Phila., and Clarence Whitman & Co., N. Y., s. agts. R. P. Deal, buyer.
- Laurel.** B. S. B. & O. RR.
- LAUREL DIVISION.;** (U. S. Duck Corp.); D. (**C**) H. Carroll, resident mgr; G. B. Timmans, supt.; Cotton Duck, Sheetings, Drills, Awning Stripes, Twines, Yarns, Etc.; 13,000 ring spindles; 250 looms; water and steam; J. Spencer Turner Co., N. Y., s. agts. (Office in Baltimore, Md.)
- Millington.** B. 9. P. W. & B. RR.
- UNICORN MILLS;** Geo. W. Todd & Co.; (**C**) E. E. Gaudbrill, supt.; Mercerized Cotton Dress Goods, Oxfords, Chambrays, etc.; 120 looms; steam and water; W. H. Bur-

gess & Co., N. Y., s. agts.; Geo. W. Todd, buyer. (Buy 20s warp, 12s filling cotton yarns, 30s, 20s filling and 40s warp 60/2 ply mercerized and others.)

**Mt. Washington.** B.S. N. C. RR.  
See Woodberry Mfg. Co., Baltimore.  
Oakland. See Baltimore.

**Oella.** B.S. B. & O. RR.  
DICKEY, W. J., & SONS; Joseph H. (C & W Holmes, supt.; Kerseys, Cassimere, Cotton Duck and Cotton Warps; 10,000 cotton spindles; 48 cotton looms; 75 broad looms; 19 sets; water; dye; W. J. Dickey & Sons, N. Y.; M. L. Record & Co, Chicago; The Warren-Wetteroth Co., St. Louis, s. agts. Wm. A. Dickey, buyer.

**Salisbury.** C.9. N. Y., P. & N. RR.  
SALISBURY KNITTING CO. *Out of business.*

**Savage.** B.S. B. & O. RR.  
SAVAGE MFG. CO.; \$500,000; W. H. Bald- (C wid, Jr., pres and treas.; Robt. Moraug, supt.; Ducks, Drills, Osnaburgs; 11,000 spindles; 300 looms; water; Woodward, Baldwin & Co., N. Y. and Balto., s. agts. (RR. station, Savage Factory.)

**Warren.** B.S. N. C. RR.  
WARREN MFG. CO.; S. Baldwin, Jr., pres. (C and treas.; C. S. Davis, supt.; S. Baldwin Jr., buys cotton, C. S. Davis buys supplies, etc.; Cotton Duck; 6400 spindles; 158 looms; steam and water; Woodward-Baldwin & Co., s. agts. (RR. station, Cocksville, two and one-half miles dis, tant.)

## KUTTROFF, PICKHARDT & CO.

Sole importers of the products manufactured by  
BADISCHE ANILIN- SODA-FABRIK,  
Ludwigshafen o/Rh., Germany,

128 DUANE STREET - - NEW YORK.

*Branch Offices:*

Boston - - - - - 153 Milk Street.  
Providence - - - 80 So. Water Street.  
Philadelphia - - - . 207 Chestnut Street.  
Chicago - - - - - 207 Michigan Street.

*Aniline and Alizarine Dyes.  
Colors, Chemicals, and Indigo.*

## MASSACHUSETTS.

See map on page 110.

For explanation of abbreviations see page 66.

**Adams.** C.2. B. & A. RR.  
ADAMS BROS. MFG. Co; Maple Grove (C Warp Mills; \$40,000; Jno. S. Adams, pres; G. B. Adams, treas.; Jno. S. Adams, Jr, supt; Cotton Warps and Yarns, 4s to 60/2; 5000 ring spindles; water and steam; dye; sell direct; G. B. Adams, buyer. Mill at Maple Grove.  
BERKSHIRE COTTON MFG. Co; \$2,500,000; (C John A. McCall, pres; W. B. Plunkett, treas.; C. T. Plunkett, sec; Z. D. Hall, supt; Fine Cottons; 123,000 ring and 135,000 mule spindles; 6100 looms; steam; sell direct.  
GRAHAM, CLARK & CO; A. A. Graham, (W supt; Men's Wear and Dress Goods; 7 sets; 42 broad and 2 narrow looms; steam and

water; dye; sell direct; Mill at Maple Grove.

PLUNKETT, W. C. & SONS; Joseph Brierty, (C supt; Cotton Warps, 8s to 60s, Chains, Beans, Bobbins and Spools; 6,000 ring spindles; water and steam; dye; sell direct.

RENFREW MFG. Co; \$1,200,000; Wm. H. (C Hill, pres.; L. B. Renfrew, treas.; J. U. Sanderson, supt; Shirtings and Damask; 23,500 ring spindles; 1392 looms; steam and water; dye; P. Van Volkenburgh & Co, N. Y., s. agts. (Buy carded 11/1 to 45/1 and 18/2 to 40/2 yarn.)

**Adamsdale.** G-11. N. E. RR.  
ADAMSDALE MILL; J. F. Adams; L. (C

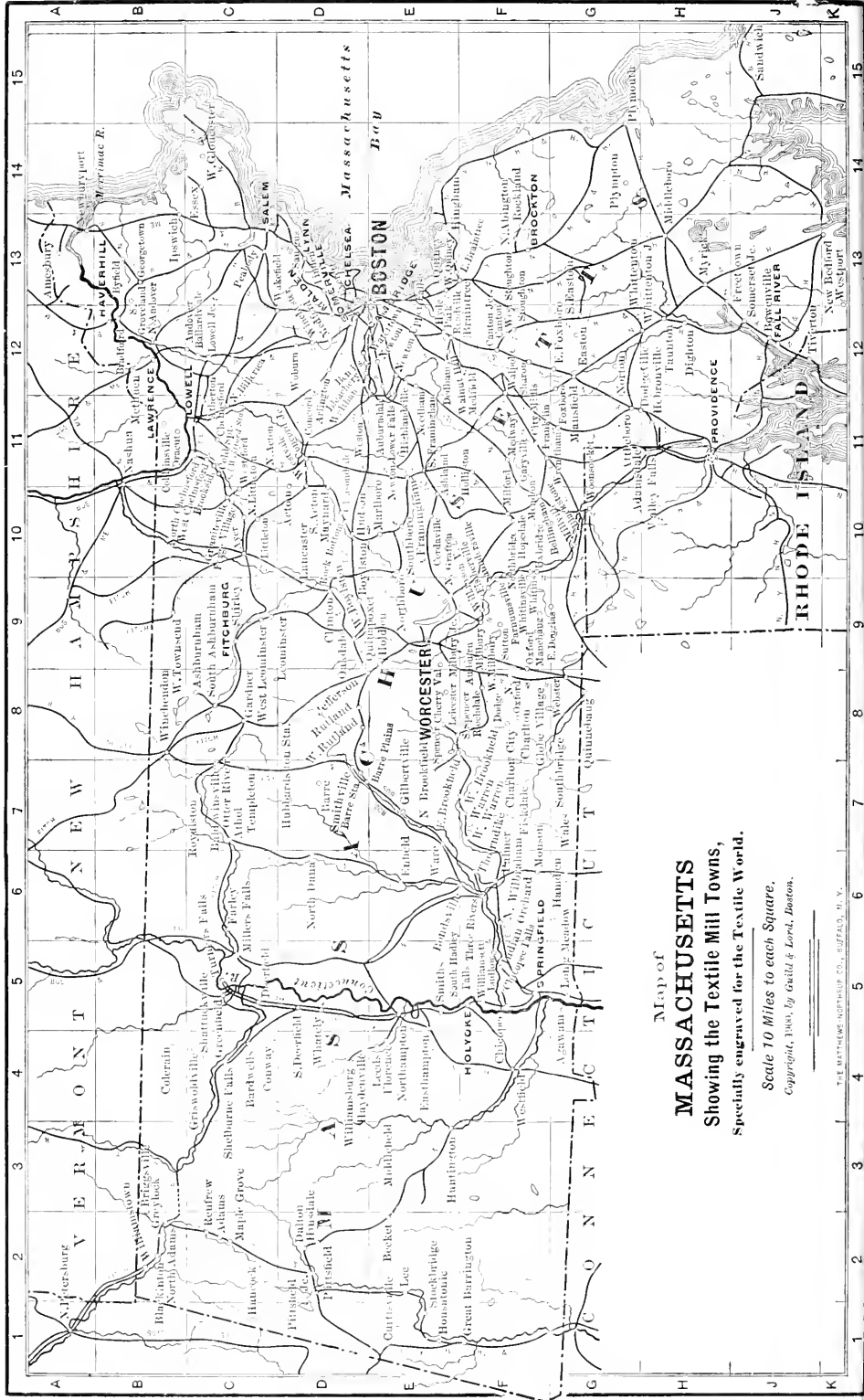

Map of  
**MASSACHUSETTS**  
 Showing the Textile Mill Towns,  
 Specially engraved for the Textile World.

Scale 10 Miles to each Square.  
 Copyright, 1900, by Gild & Lord, Boston.

THE MATTHEW-NORTHROP CO., BUFFALO, N. Y.

Handy, supt; Fine Cotton Yarns; 5040 spindles; steam and water; W. M. & F. W. Sharples, Phila., s. agts. and sell direct.

**Agawam.** G-5. Stage and electric cars 3m at Springfield, on B. & A. RR.

AGAWAM CO.; \$50,000; Samuel Payne, (W) pres; Fred A. Sykes, treas; Samuel Payne, agt; Woolen Flannels and Dress Goods; 4 sets; 28 looms; water and steam; dye; sell direct.

**Amesbury.** A-13. B. & M. RR, E. Div.

HAMILTON WOOLEN CO.; \$1,000,000; C. A. (C) Coleman (Boston), treas; M. W. Quinn, agt; F. J. Quinn, supt.; Prints and Sheetings; 63,000 ring spindles; 1800 looms; steam and water; Joy, Langdon & Co., N. Y. and Boston, s. agts. (Buy 288 on section beams.) Mills also in Globe Village, Mass.

MERRIMAC HAT CO.; \$200,000; Geo. F. (W) Bagley, pres; Thos. E. Cutter, treas; Wm. W. Martiu, supt.; Soft Wool Hats; 15 sets; steam; dye; Wm. Carroll & Co., N. Y., s. agts.

**Andover.** C-12. B. & M. RR, W. Div.

MARLAND MILLS; See M. T. Stevens & (W) Sons Co.; No. Andover; Chas. L. White, supt.; Ladies' Dress Goods; 14 sets; 16 looms; water and steam; dye.

SMITH & DOVE MFG. CO.; \$500,000; (F) Geo. H. Torr, pres; Peter D. Smith, treas; John W. Bell, agt. and buyer; Shoe Threads, Yarns and Twines; steam and water; dye; sell direct.

**Arlington.** D-12. B. & M. RR.

DALE, MRS. MARGARET; Cotton Mops. (C)

**Ashburnham.** C-8. Fitch. RR.

ASHBURNHAM SHEETING MILL. See (C) Fitchburg.

**Athol.** C-7. B. & A. RR, Athol Br, and Fitch. Div., B. & M. RR.

ADAMS, D. E.; C. L. Morse, supt; (S) Sewing Silk, Machine Twist, Floss and Embroideries; water and steam; dye; sell direct; Boston, N. Y. and Chicago.

EAGLE WOOLEN MILLS; Mrs. S. J. (W) Handy; \$4000; E. S. Handy, Atty. and supt; Satinets; 2 sets; 20 looms; steam and water; Bacon & Co., s. agts.

KAUFFMAN, W. H.; Satinets and Blank. (W) ets; 2 sets; 32 narrow and 10 broad looms; steam and water; dye; W. Storey & Son, N. Y., s. agts.

MILLER RIVER MFG. CO.; \$30,000; H. R. (W) Stowell, pres; E. C. Gaynor, treas, agt. and supt; Horse Blankets, Blankets and Duck Coat Linings; 5 sets; 48 looms; water; Thomas Kelly & Co., Boston, s. agts.

PARTRIDGE, E. E & Co; W. A. Munn, (W) supt; Satinets, Blanket Cloth and Linings; 3 sets; 12 looms; 240 spindles; steam and water; Bacon & Co., N. Y., s. agts; E. E. Partridge, buyer. (Buy No. 16 and 18 yarns.)

**Attleboro.** G-11. N. Y. N. H. & H. RR, Prov. and Taunt. Divs.

WOLFFENDEN, R. & SONS; Attleboro (D&H) Dye Works; O. Wolfenden, supt; J. W. Wolfenden, buyer; Dyers and Bleachers of Woolen and Worsted Yarns, Braids, Tapes, Hosiery, Plush, Webbing, etc., for all Purposes; Fast Black and Colors a Specialty; Spooling, Jack Spooling and Coning; steam. (Capacity 6,000 lbs. per day.)

GOLD MEDAL BRAID CO.; \$30,000; (C, W & S) Harvey Clap, pres; H. F. Barrows, Jr, treas; E. E. Rockwood, agt. and buyer; Cotton, Worsted and Mohair Braids, Dress Facings, Shoe Laces; 2000 braiding machines; water; sell direct and Geo. A. Miller, Boston, s. agt. (Buy 2/16 to 2/36 worsted and 2/20 to 2/40 cotton yarns.) (P. O. address Attleboro Falls.)

ORR, JAMES; Geo. W. Orr, supt; (D & F) James W. Orr, buyer; Dyers and Finishers of Yarns; also Spooled; steam; sell direct. (Buy Cotton yarn, Egyptian, Northern and Southern in Skeins only from 12/2-50/2 and 10/1-50/1.)

**Auburn.** F-9. N. Y. & N. E. RR. (Electric from Worcester.)

PONDVILLE WOOLEN CO.; Sidney Segal, (W) treas.; M. G. Rosenberg, sole mgr.; Fred A. Lapham, supt; 5 sets; 42 looms. (In the Crossley Mill.)

HILTON, JAS; Mattress Floeks and (W) Shoddy; 2 pickers; water; sell direct; James Hilton, buyer.

HOGG CARPET CO.; (P. O. address Worcester.) \$15,000; H. A. Moore (Flushing, N. Y.), pres.; William F. Hogg, t. cas.; Brussels and Wilton Carpets and Rugs.

HOGG, WM. JAS. & Co. (P. O. Address, (W) Worcester); J. E. Cunningham, supt; Worsted Yarns; 3539 spindles; steam and water; sell direct; Wm. Jas. Hogg, buyer.

**Ballardvale.** C-12. B. & M. RR, W. Div.

BALLARDVALE MILLS; W. H. Hodgkins, (W) trustee; H. F. Wilson, mgr; J. Shaw, supt; Fine White Flannels; 15 sets; 130 looms; steam and water; Cabot, Jones & Kelley, N. Y. Boston and Phila., s. agts; H. F. Wilson, buyer.

**Barre.** D-7.

ORIENTAL RUG WOLKS; S. A. Morse; (J) Rugs from Old Carpets. (See Skowhegan, Me.)

SMITHVILLE MILL. See Smithville.

**Becket.** E-2. B. & A. RR.

BECKET SILK CO.; S. K. Smith, prop.; (S) Silk and Mohair Braids, Machine Twist, etc; 50 braiders; steam and water; dye; sell direct.

**Bellingham.** F-10.

TAFT, MURDOCK & Co. See Careyville. See also North Bellingham.

**Bemis.** D-12 Fitch. RR, W. Br.

BEMIS MILLS; R. E. Goodwin (Augusta, (W) Me.), prop; Geo. Crossland, supt; Worsted Goods, for Men's and Ladies' Wear; (English system); 1 comb; 2 sets worsted cards; 2200 spindles; 64 looms; steam; dye; sell direct and Hardt Von Bernuth & Co., N. Y., s. agts; Geo. Crossland, buyer. (Buy cotton and worsted yarns.) (P. O. address, Watertown.)

**Billerica.** C-11. See North Billerica.

**Blackinton.** B-2. In No. Adams, B. & M. RR.

WATERHOUSE & BUFFUM; (formerly (W) Blackinton Co.; I. H. Waterhouse, supt.; Worsteds for Men's Wear; 16 sets; 130 looms; water and steam; dye; Sullivan, Vail & Co., N. Y., s. agts.; firm, buyers. (Buy 2-16 to 2-50 yarn.)

**Blackstone.** G-10. N. Y. & N. E. RR. and N. Y. N. H. & H. RR, Wor. Div. See also Millville.

BLACKSTONE MFG. CO.; \$500,000; Wm. (C) Butler Duncan, pres; Robt. L. Gammell, treas; Goddard Bros. (Prov.), agts; G. E. Spofford, supt; Sheetings and Shirts; 17,600 ring and 25,836 mule spindles; 121 looms; water and steam; Moss, Taylor & Co., N. Y., s. agts.

EAST BLACKSTONE YARN CO.; Sumner (W) Fairbanks & Co.; (formerly A. H. Lange); Woolen and Merino Yarns; 2 sets; 16 looms; dye. (Mill at East Blackstone.) *Burned March, '02.* Do not know now about rebuilding.

FARWELL WORSTED CO. See Central Falls, R. I.

SARANAC MILLS; (American Woolen (W) Co.); Wm. M. Wood (Boston), treas.; J.

- Harvey Merrill, agt.; Worsted Suitings, Men's Wear; 8 sets; 224 looms; steam and water; dye; J. Clifford Woodhull, N. Y., s. agt.
- THAYER WOOLEN CO. See No. Oxford.
- Bondsville.** F. G. B. & A. R. R. Athol Br and B. & M. RR, Cent. Mass. Div.
- BONDVILLE BL. & DYE WORKS; (B1 & D)** \$350,000; Geo. F. Fabyan, treas.; E. G. Childs, agt.; Finished Duck Flannels, Cambric, Sheetings, Shoe Goods, (Aniline Blacks,) Etc.; steam; electricity and water.
- BOSTON DUCK CO;** \$350,000; Geo. F. (C) Fabyan, treas.; E. G. Childs, agt.; S. Stewart, supt.; Duck, Flannels, and Blankets; 18,000 ring spindles; 400 looms; water; steam and electric; Bliss, Fabyan & Co. N. Y. Boston and Phila, s. agts.
- Boston.** E. L. B. & A. B. & M. B. R. B. & L. Fitch, N. Y. & N. E., and N. Y., N. H. & H. RRs.
- AMERICAN WOOLEN CO.;** Fred'k Ayer, (W) pres.; William M. Wood, treas. Ames Bdg, Boston, Mass.; Edward P. Chapin, asst. treas. and gen'l agt, Ames Bdg, Boston, Mass.; J. Clifford Woodhull, s. agt., 66-72 Leonard St., N. Y. Gen'l purchasing agt. Hiram J. Potter, Ames Bdg, Boston, Mass.; Yarn Dept., H. C. Jealous, mgr, Ames Bdg, Boston, Mass.; Shoddy and Waste Dept. Herbert Taylor, Mgr.; Supervising Engineer, William S. Whitney, Lawrence, Mass.; Chemist, Wm. D. Livermore, Lawrence, Mass.; Traffic Agt., E. A. Gordon, Ames Bdg, Boston, Mass.
- Washington Mills, Lawrence, Mass.  
Globe Mills, Lawrence, Mass.  
Prospect Mills, Lawrence, Mass.  
Nat'l & Prov. Worst. Mill, Providence, R. I.  
Saranac Mills, Blackstone, Mass.  
Fulton Mills, Fulton, N. Y.  
Fitchburg Mills, Fitchburg, Mass.  
Beoli Mills, Fitchburg, Mass.  
Valley Mills, Providence, R. I.  
Riverside Mills, Providence, R. I.  
Assabet Mills, Maynard, Mass.  
Sawyer Mills, Dover, N. H.  
Bay State Mills, Lowell, Mass.  
Beaver Brook Mills, Collinsville, Mass.  
Vassalboro Woolen Mills, Vassalboro, Me  
Lebanon Mills, Lebanon, N. H.  
Puritan Mills, Plymouth Mass.  
Anderson Mills, Skowhegan, Me.  
Manton Mills, Manton, R. I.  
Anchor Mills, Harrisville, R. I., Pascoag R. I.  
Chase Mills, Webster, Mass.  
Brown Mills, Dover, Me.  
Ray's Mills, Franklin Mass.  
Weybossett Mills, Providence, R. I.  
Baltic Mills, Enfield, N. H.  
Moosup Mills, Moosup, Conn.  
Kennebec Worsted Mills, Fairfield, Me.  
Burlington Mills, Burlington, Vt.
- ADAMS BROS;** Office, 571 Atlantic Ave; (C) Waste; steam. Mill at So. Boston.
- AMERICAN NET and TWINE CO;** 93 Com. (C) mercial St.; \$350,000; Willis S. Shepard, pres.; Ivers W. Adams, treas.; Nets, Seines, Lines and Twines; 150 netting looms; steam; sell direct. (Mill at East Cambridge. See also Anniston, Ala.)
- BATES, C. & Co;** 29 Temple Place; Silk, (K) Wool, Merino and Gauze Underwear, and Athletic Goods; 5 knitting machines; 4 sewing machines; sell direct; C. Bates, buyer. (Buy 40 to 60 yarns.)
- BISHOP, ROBERT;** Est. of; 157 W. 6th (C & D) St.; RR. Wiping Waste and Carpet Lining; 30 cards; also Dyer of Cotton.
- BOSTON BRAID MFG. CO,** 42 Thayer St.; (S) E. V. Fiedler, mgr; Tassels, Cords, Ribbons, Fringes, etc.; steam.
- BOSTON BUTTON CO;** 326 A. St. So. Bos (C) ton; Vestings and Button Stock; 24 looms; buy Silk and Cotton Yarns; steam; sell direct.
- BOSTON SILK CO.;** 251 A St; Commission (S) Throwsters; Tram, Floss, etc.; 1700 spindles.
- BOSTON SILK WINDING CO.;** D. P. Bedell, (S) Bedell, mgr.; 16 Columbia St.; Winding; 3 silk winders.
- BOSTON THREAD & TWINE CO;** 178 (B1 & C) Devonshire St; \$80,000; John H. Ross, pres; Henry F. Ross, treas; John C. Ericson, supt; Yarn, Thread and Twine. Mill at Jamaica Plain.
- CALLAHAN, CORNELIUS, CO., THE INC.;** (K) \$20,000; 127 Purchase St.; Walter Cutting, pres; M. S. Crehore, treas and supt.; Knit Fire Hose; 9 knitting machines; steam; sell direct. M. S. Crehore, buyer.
- CHESTER SUSPENDER CO.;** A. Zieg. (C, W & S) ler & Sons; 111 Chauncy St; Trimmings, Webbing and Suspenders; 87 power looms; steam. Mill at Roxbury.
- FORD, R. J. & CO;** 109 Kingston St; In- (K) fant's Fine Knit Shirts, Bands, etc.
- GORDON MFG. CO.,** 537 Albany St; F. D. (C) Gordon, prop.; Duck Coats; 12 looms; 26 sewing machines; steam; sell direct.
- HOLMES CO, THE;** 29 Troy St; James (K) Dickinson, pres.; M. A. G. Dickinson, treas. Athletic Knit Goods and Union Underwear, Cotton, Wool and Silk; 82 knitting machines; 24 sewing machines; steam; sell direct.
- HOWARD MFG. CO;** \$40,000; W. C. How. (C) ard, pres; Samuel Ainsworth, treas; Elastic Goods and Yarns; steam; S. E. Howard's Son & Co, N. Y., s. agts. (Mill in Charlestown, which is also P. O. address.)
- HUB GORE MAKERS;** Lincoln St., Al. (C) bany Bdg; \$1,500,000; Wm. Rapp, pres. and supt; E. B. Page, treas; John E. Page, asst. treas. and buyer; Shoe Goring, known as "Hub Gore," and "Bridgeport Gore," Corset Bandage, Elastic Belts and Truss Webs; 300 looms; steam; sell direct. (Mill at Brockton.) (Buy 10/2 up to 80/2 warp and skein yarns.)
- HUB HOSIERY MILLS,** 520 Harrison Ave; (K) \$10,000; H. V. Noyes, pres; Frank R. Tackaberry, treas; Infant's Cashmere Hosiery; 30 knitting machines; steam; sell direct. (Buy worsted yarns.)
- IPSWICH MILLS (branch),** 158 Second St, (K) So. Boston; J. J. O'Brien, supt; Hosiery; See Ipswich.
- KINGSTON KNITTING CO.;** 37 Kingston St; (K) E. Carroll, supt; Athletic Goods, Bathing Suits, Jerseys, etc; 25 knitting and 10 sewing machines; steam; sell direct; Herbert V. Brine, buyer.
- LADD, GEO. W. & Co;** 139 Columbus Ave; (K) Surgical Elastic Goods, Stockings, Belts, Etc.; 7 knitting machines; steam and hand power; sell direct; Geo. W. Ladd, buyer.
- LOWENTHAL WM. & Co,** 18 W. First St. (W) (So. Boston); Cotton, Woolen and Merino Waste; 5 dusters; gas engine. (Also West Milbury, Mass., and Cohoes, N. Y.)
- MASSACHUSETTS STATE PRISON;** B. F. (C) Bridges, Warden; Cotton Goods for Institution use; 55 hand looms.
- MERRILL, J. F.;** 22 Norfolk Ave; Cotton (C) Yarn and Threads; steam; sell direct.
- MILLER, A. H.;** office, 563 Atlantic Ave; (W) factory, 1359 Columbus Ave, Roxbury; Shoddy and Flocks; 20 cards; 6 pickers; 2 garnet machines.
- MORSE, E. J. W., Co.;** (American Thread Co.) *Removed to Willimantic, Conn.*
- NEW ENGLAND DYEING & FINISHING (D & F) Co;** (not inc.) rear 341 Codman St. Dorchester; Converters of Cotton Goods; steam.
- PEERLESS UNION UNDERWEAR CO.;** 16 (K) Ash St.; Union Suits and Equestrian Tights, Full Fashioned; R. A. Scott & Co., 49 Temple Place, s. agts.; R. A. Scott, buyer. (Buy yarn.)



**ROXBURY CARPET CO.**; \$120,000; Frank (W) E. Simpson, pres; Wm. Butler, treas; Tapestry and Velvet Carpets; 140 looms; sell direct; Office, 93 Summer St. Mills at Roxbury.

**SCHOENFUSS, F. J.**; 383 Washington St.; 8 Fringes, Cords, etc; 5 looms.

**SEWALL & DAY CORDAGE CO.**; 45 Broad (J) St.; (Inc. 1880); P. O. Box 2339; \$100,000; Thos. Russell, pres; Horatio Davis, treas; and agt; Cordage, Window Lines, Binders' Twine, etc. (Mills at Brighton.)

**SIMPLEX ELECTRICAL CO.**; 75 Cornhill; (C) \$250,000; C. A. Morss, pres; C. A. Morss, Jr, treas; Everett Morss, vice-pres; J. H. Mason, gen'l mgr; Insulated Wire and Cables; 300 braiders; steam; treas; and gen'l. mgr, buyers. Factory at Cambridgeport.

**STERLING KNIT GOODS CO.**, 22 Randolph (K) St.; \$10,000; W. A. O'Brien, pres; John C. Edwards, treas; Fred C. Cook, supt; Sweaters, Infants' Hosiery and Fashioned Underwear; 15 power and 50 hand knitting machines; steam; Verdier & Hardy, N. Y.; J. F. Hallissy, Chicago and H. A. Austin & Co, Boston, s. agts; pres. and supt, buyers.

**STOHN, C.**, 178 Green St. (Jamaica (W & S Plain); Gustave F. Kleindienst, supt; Silk Button-stuff, Fancy Vestings and Novelties; 52 looms; buy fine ply warps and filling; steam; sell direct.

**TOPHAM, F. H.**; 266 Devonshire St; Knit (K) Goods; 50 knitting machines.

**UNION CARPET LING CO.** See Watertown.  
**UNION HAMMOCK MILLS**; 199 B St.; R. (C) W. Hull, pres and buyer; R. T. Hull, agt; A. B. Kingsley, supt; Woven Hammocks and Novelties; 6 looms; 6 sewing machines; steam; sell direct.

**U. S. NAVY YARD** (Charlestown); Fred (J) A. Jenks, supt.; Manila and Sisal Rope and Cordage; 200 spindles.

**WEINZ TRIMMING CO.**; \$10,000; Office, 44 (S) Bedford St.; H. L. Weinz, pres. and treas; Trimmings; 35 looms; steam; sell direct. Mill, 280 Dover St.

**WHITE, C. W. & Co.**; 99 Court St; Elastic (K) Hosiery; 12 knitting machines; electric power; sell direct.

**ZEIGLER, CONRAD**; 54 George St.; Silk (D) and Cotton Dyer.

**Bradford.** B-12. B. & M. RR, W. Div.

**BRADFORD HAT FACTORY**; J. P. Gilman's Son; (P. O. address, Haverhill); Wool Hats; 7 sets; steam; dye; Taylor & Seeley, N. Y. s. agts.

**Braintree.** F-13. N. Y., N. H. & H, RR, Plym. Div. See East Braintree.

**TROTT, JOHN C. CO.**; \$15,000; Henry C. (C) Everett, pres; John C. Trott, treas; J. Alden Trott, supt; Medicated and Absorbent and Jewelers' Cotton; 15 cards; steam and water; dye; sell direct; John C. Trott, buyer.

**Brockton.** F-13. N. Y., N. H. & H, RR, Plym. Div.

**HUB GORE MAKERS.** See Boston.

**Brookfield.** See East and No. Brookfield.

**Byfield.** B-13. B. & M. RR, W. Div.

**BYFIELD WOOLEN CO.**; \$50,000; Samuel (W) Williams, pres; Alfred S. Williams, treas; Wm. Taylor, supt; Blankets and Felts; 15 sets; 32 broad looms; steam and water; dye; sell direct; Samuel and Alfred S. Williams, buyers. (Buy 1-12 and 1-16 Cotton warps.)

**Cambridgeport.** D-12. In Cambridge, on Fitch RR.

**BOSTON WOVEN HOSE & RUBBER CO.**; (C) \$1,200,000; J. N. Smith, pres; H. B. Sprague,

treas; A. M. Paul, gen'l mgr.; T. J. Richards, supt.; Cotton Rubber Lined and Unlined Linen Hose; 10 circular and 4 flat looms; steam; sell direct; J. F. French, buyer. (Buy No. 8 and 22 cotton and 16/3 flax yarn.)

**Canton.** F-12. N. Y., N. H. & H, RR, Prov. Div.

**DRAPER BROS CO.**; \$200,000; Thomas (K & W) B. Draper, pres; Charles N. Draper, treas; Directors act as supts; Fancy Knit Goods, Rubber Boot and Shoe Linings, Paper and Pulp Makers Felts; 9 sets; 68 knitting machines; 12 looms; steam; dye; sell direct. (Buy 5s to 60s cotton yarn.)

**DRAPER'S, ROBERT, SONS.**; Rubber (C & K) Linings, Hosiery and Warp Yarns and Ladies' Ribbed Underwear; 1600 cotton spindles; 58 knitting and 15 sewing machines; steam; sell direct.

**EUREKA SILK CO.**; \$625,000; T. King, pres; (S) Sewing Silk, Machine Twist and Embroidery Silk; 10,000 spindles; water and steam; dye; sell direct; (40 Summer St., Boston; 542 Broadway, N. Y.) (In hands of receivers, reported reorganizing April, '02)

**MANSFIELD, G. H. & Co.**; Braided Silk (S) Fishing Lines; 120 braiders; water; sell direct; Geo. H. Mansfield, buyer. (Buy silk threads.)

**Canton Junction.** F-12. N. Y., N. H. & H, RR, Prov. Div.

**CALLAHAN, CORNELIUS.**; Fire Hose; 4 (C) knitting and 1 circular loom; steam; sells direct. (Buys cotton yarn).

**CANTON MFG. & BLEACHING CO.**; Plant closed. New company may be organized.

**KNITTED MATTRESS CO.**; \$35,000; G. P. (K) Sumner, pres; Fred W. Sumner, treas. and supt; Mattresses, Stair Pads, Table Padding, Mattress Pads, Protectors, Bolsters and Pillows, Padding of all kinds; 3 sets; 9 knitting machines; steam; sell direct. (Buy 8/1 on Beams and Tubes, and 12/3 on Tubes.)

**Caryville.** F-11. In Bellingham, N. Y. & N. E. RR, Woon. Div.

**TAFT, MURDOCK & Co.**; Caryville Mills; (W) David Bigwood, supt.; Union Cassimeres, Satinets; 11 sets; 123 looms; steam and water; dye; Mackintosh, Taft & McKenney, N. Y. s. agts.; E. W. Murdock and A. E. Ballard, buyers.

**Chapinville.** E-10. In Northboro. N. Y. N. H. & H, RR. (Northern Div.)

**NORTHBORO WOOLEN MILLS, THE.**; (W) (Louis Bachmann, N. Y. Jessee); Railroad and telegraph station, Northboro. E. W. Chapin, mgr; Robt. Illingsworth, supt; Union Cassimeres and Overcoats; 12 sets; 114 looms; water and steam; dye; sell direct, 86 Franklin St., N. Y.; E. W. Chapin, buyer, wool; L. Bachmann, rag stock. (Buy No. 14 black warp.)

**Charlestown.** See Boston.

**Charlton City.** F-8. B. & A. RR.

**AKERS & TAYLOR**; H. C. Grimwade, (W) supt; Satinets, Cassimeres, Cloakings and Kerseys; 7 sets; 102 looms; water and steam; dye; Bacon & Co, N. Y., and Boston, s. agts; Fred S. Taylor, buyer. Two mills.

**ALDRICH MFG. Co.**, Satinets. (See "To (W) Late" list for machinery).

**Chelsea.** D-13. In Boston. B. & M. RR, E. Div.

**AMERICAN CIRCULAR LOOM CO.**; High. (C) Innd and Suffolk Sts. (Inc. 1889); \$100,000; A. F. Smith, pres; A. T. Clark, treas; Flexible Conduits for Electrical Purposes; buy 4 to 9-ply 6s; 50 looms; steam.  
**AMERICAN FIRE HOSE MFG. CO.**; (Inc. (C) 1880); \$100,000; E. E. Sibley, mgr; Knitted Fire Hose Fabric; 12 looms. In hands of C. C. Blaney and James Gould, for creditors.

- BOSTON GORE & WEB MFG. CO;** \$20,000; (C) Edmund A. Hopkins, pres; Alfred Hopkins, treas; Shoe and other Webs and Goring; 24 looms; steam; sell direct; Alfred Hopkins, buyer. (Buy 10/2 to 80/2 Peeler and Egyptian yarn.)
- CHADBOURNE & MOORE;** J. H. Chad. (C) Bourne, agt.; Geo. C. Moore, supt. and buyer; Elastic and Non-Elastic Webs; 82 looms; steam; sell direct; 145 South St., Boston. (Buy yarn, 12/1, 12/2, 16/2, 20/2, 26/2, 30/2, 40/2, 50/2, 60/2, 70/2, 120/2.)
- CHELSEA CORDAGE CO.** (Standard Co.), (J) 45 Broad St; Horatio Davis, mgr; Cordage, Binder Twine, etc; steam. (*Not running.*)
- MARTIN, T. & BRO. MFG. CO;** \$200,000; (C) Wm. Martin, pres; Thos. Martin, treas; J. O. Fryer, sec; Elastic Webbing, Braids, Cords, etc; 175 looms; 200 braiders; steam; office at 108 Worth St, New York City; William Martin, buyer.
- MARTIN, WM. & SONS;** Suspenders Webs; (C) 22 looms; steam; T. Martin & Bro. Mfg. Co, N. Y., s. agts.
- WALKER BROS;** Dyers; Cotton Yarn; (D) steam.
- Cherry Valley.** E.9. Electric cars 4m from Worcester, 2m from Jamesville station, on B. & A. RR.
- PFÄFFMANN, PHILIP;** Hunts Mill; Sati. (W) nets; 2 sets; 32 looms; steam and water; sell direct and Sawyer & Blake, s. agts.; Phillip Pfaffmann, buyer
- CHAPEL MILLS MFG. CO;** \$23,000; H. J. (W) Brouard, pres; Channing Smith, treas; Geo. W. Vickery, supt.; Chevriots and Overcoatings; 4 sets; 72 looms; Converse, Stanton & Co, N. Y., & Boston, s. agts.; Channing Smith, buyer. (Buy cotton yarn, 16s to 26s)
- DARLING, A. W;** Bottomly Mill; Michael (W) J. Shaughnessy, supt; Chevriots, Unions and Satinets; 4 sets; 1080 spindles; 50 looms; steam and water; dye; Lawrie, Mann & Drowne, N. Y., s. agts.
- OLNEY, GEO. W. WOOLEN CO;** \$75,000; (W) Thomas W. Olney, pres; Geo. H. Olney, treas; Blankets and White Flannels; 8 sets; 58 looms; steam; dye; Deering, Milliken & Co, N. Y. and Boston, s. agts; Geo. H. Olney, buyer.
- SHEPARD, JOHN J;** (formerly E. Col. (W) tier); Satinets; 1 set; 440 mule spinners; 14 looms; water and steam; sell direct.
- THAYER, E. D. JR;** W. H. Arthur, supt; (W) Chevriots and Flannels; 8 sets; 86 looms; water and steam; dye; goods sold thru gls. agts.
- VALLEY WOOLEN MILL;** Channing (W) Smith, prop; A. E. Smith, supt.; Cyrus W. Bens n, asst. supt.; Flannels and Dress Goods; 4 sets; 80 looms; steam and water; dye; Converse, Stanton & Co, Boston and New York, s. agts.; Channing Smith, buyer. (Buy cotton yarns, 18s to 36s.)
- Chicopee.** F.5. B. & M. RR, Conn. Riv. Div.
- BURTWORTH CARPET CO;** \$10,000; Geo. (W) W. Kimball, pres; F. B. Strickland, treas. and agt; H. K. Martin, supt; Wilton and Brussel Carpets and Rugs, All Sizes; 16 looms; water; dye; W. & J. Sloane, s. agts; F. B. Strickland, buyer. (Buy cotton, worsted, jute and linen yarns.)
- DWIGHT MFG. CO;** \$1,800,000; T. Jefferson (C) Coolidge, pres; J. H. Nichols, treas; Louis A. Annann, agt.; Frank L. Simpson, supt; Sheetings, Shirtings and Dress Goods; 130,000 spindles; 3436 looms; steam and water; Mmot, Hooper & Co, N. Y. and Boston, s. agts. (Also Alabama City, Ala.)
- OLMSTED & TUTTLE CO;** \$100,000; F. E. (C) Tuttle, pres. and treas; H. F. McGrady, agt and supt; Wiping and Packing Waste, Comfortables, Carpet Lining, Horse Blankets, Mops, Spinning, Bating and Paper Stock; steam; dye; sell direct; treas. and agt., buyers.
- RUSSELL KNITTING CO;** Mittens and (K) Gloves; 25 knitting machines.
- Chicopee Falls.** F.5. B. & M. RR, Conn. River Div.
- CHICOOPEE MFG. CO;** \$1,000,000; E. P. (C) Beebe, pres; Geo. S. Silsbee, treas; Henry A. Bailey, agt; Geo. W. Haselton, supt; Cotton Flannels, Domets, Cotton Blankets and Sheetting; 76,768 ring spindles; 2047 looms; water and steam; Catlin & Co, N. Y, Phila. and Boston, s. agts; Geo. H. T. Babbitt, buyer.
- HAMDEN BLEACHERY;** Daniel J. Dunn, (BI) pres; Eugene J. O'Neil, treas. and buyer; James F. Ash, supt; Bleached and Fin ished Cotton Cloths; steam and water.
- TAYLOR, BRANLEY CO, THE;** \$20,000; Al. (K) bert E. Lane, pres. and agt.; Albert E. Taylor, treas.; Walter Branley, supt; Ladies' and Misses' Ribbed Underwear and Athletic Goods; steam; sell direct; A. E. Lane, N. Y., Life Bldg., N. Y.; A. E. Taylor and W. Branley, buyers. (Buy worsted yarns, 11, 18, 30, 40, single and 37, also 2/40, 2/37; cotton, 10-11-12-22-26, combed peeler on cones.)
- City Mills.** F.11. See Norfolk.
- Clinton.** D.9. N. Y., N. H. & H. RR, No. Div. and B. & M. RR, WN. & P. Div.
- BIGELOW CARPET CO;** \$4,030,000; Arthur (W) T. Lyman, pres; Chas. F. Fairbanks (Boston), treas; E. W. Burdett, supt; Wilton Brussels Ingrain and Axminster Carpets and Woolen and Worsted Yarns; 32,692 worsted and 9488 mule spindles; 42 combs; 84 sets worsted cards; 69 sets woolen; 804 looms; water and steam; dye; Henry P. Fairbanks, 143 Fifth Ave. N. Y., s. agt. Chas. F. Fairbanks, buyer. (Buy cotton, jute and linen yarn.) (Above item includes machinery of plant at Lowell.) *See also Lowell.*
- CLINTON BRAID CO;** \$7,500; A. S. Paton, (C) pres; T. S. Davis, treas; Brush Braid; 2 looms; steam and water.
- CLINTON WORSTED CO;** Wm. Rodgers, (W) treas; John Rodgers, supt; Worsted; 6 sets; 3 combs; 2,016 worsted spindles; 96 looms; water and steam; Fred'k Victor & Achilles, N. Y., s. agt.
- LANCASTER MILLS;** \$1,200,000; C. Minot (C) Weld, pres; Harcourt Armory, treas; Chas. H. Richardson, agt; W. G. McLoon, supt; Gingham, Cotton Flannel, Fancy Shirtings and Fine Dress Goods; 82,000 spindles; 3500 looms; steam; dye; Amory, Browne & Co, Phila., N. Y. and Boston, s. agts.
- STERLING WORSTED CO;** \$50,000; A. A. (W) Jenkins, pres; Chas. Frazier, treas; Geo. S. Giffin, agt, supt and buyer; Worsted Trouserings and Suitings; 2 sets; 20 looms; steam; dye; Oelbermann, Dommerich & Co., s. agts.
- Cold Spring.** C.H. Station Westford, on B. & M. RR, So. Div. and C. & M. RR, N. A. & B. Br.
- SHEEHAN, D. H;** Cotton and Camel's (W) Hair, Bagging for Oil and Cider Presses; 3 looms; steam and water; sell direct.
- Colerain.** B.4. See Griswoldville and Shut-tuckville.
- Collinsville.** B.H. Station at Lowell, on B. & M. RR, So. Div.
- BEAVER BROOK MILLS;** (American (W) Woolen Co.); W. M. Wood, (Boston), treas; John Allen, agt; Maurice Herbert, supt; Kerseys and Thibets; 39 sets; 168 looms; steam and water; dye; J. Clifford Wood-hull, N. Y., s. agt; H. J. Potter, (Boston), buyer.

**Concord Junction.** D-II. B. & M. RR. P. RR, N. Y, N. H. & H. RR.

MASSACHUSETTS REFORMATORY; (C & W James Dunlop, Jr, supt; Cheviots, Suitings, Cassimeres and all Textile Goods used in State Institutions and Hosiery; 3 sets; 2600 ring spindles; 100 looms; 6 knitting machines; dye.

**Conway.** C-4. N. Y, N. H. & H. RR, Northampton Div.

DELABARRE MILL; 8 sets; 36 looms; (W) steam and water; dye. *Idle.* For Sale.

TUCKER & COOK MFG. Co; \$60,000; A. M. (C) Cook, treas; C. Cook, agt. and pres; Warps and Knitting Cotton; 5000 spindles; steam and water; dye; sell own yarns.

**Cordville.** E-10. In Southboro, B. & A. RR.

CORDAVILLE WOOLEN Co; \$50,000; W. C. (W) Metcalf, pres; B. F. Merriam, treas; J. J. Henderson supt; Blankets and Felts; 8 sets; 50 looms; steam and water; dye; The Allen Lane Co, N. Y. and Boston, s. agts.

**Dalton.** D-2. B. & A. RR.

CRANE BROS.; John P. Crane, agt. and (C) supt.; Hygienic Bath Towels; 6 looms; steam; sell direct.

REDDICK, W. H. & Co.; formerly An- (W) drews & Reddick; Dalton Woolen Mill; Jas. H. Hendry, supt; Overcoatings and Suitings; 7 sets; 35 looms; water; dye; sell direct.

**Dana.** See No. Dana.

**Dedham.** E-12. N. Y, N. H. & H. RR, Prov. Div.

LORIO, JACOB; Cardigan Jackets and (K) Sweaters; 4 knitting machines; steam; sell direct.

MERCHANTS DYE WORKS; E. D. Thayer, (D) Jr, prop; Benj. M. Earle, agt.; B. M. Earle, Jr., supt.; Colored and Carded Cottons, Spooling and Cone Winding; steam and water; sell direct; P. O. address, East Dedham. (Buy cotton yarns, all numbers.)

MERCHANT'S WOOLEN MILL; E. D. (W) Thayer, Jr, prop, Worcester; W. H. Brothers, supt; Kerseys, Cheviots, Dress Goods and Overcoatings; 20 sets; 192 broad looms; water and steam; dye; H. Bassendahl & Co., and Nostrand & Moore, s. agts. E. D. Thayer, Jr, buyer. (P. O. address, East Dedham.)

NORFOLK MILL; Cochrane Mfg. Co; (W) \$250,000; John Cochrane, pres; J. Eugene Cochrane, treas; J. P. Walsh, agt and supt; Carpets, Velvets and Tapestry; 8 sets; 50 looms; dye; water and steam. (P. O. address East Dedham.) J. E. Cochrane, buyer. (Also Danielson, Conn.) N. Y. office 87 Worth St.

RADCLIFFE, WM; Cardigan Jackets; 7 (K) knitters; (P. O. address, West Roxbury.)

**Dighton.** H-12. See No. Dighton.

**Dodge.** F-8. (RR. station, Charlton Depot) N. Y. C. & H. R. RR.

PIKE, C. W; Satinets and all kinds of (W) yarn; 1 set; 288 spindles; 26 looms; steam and water; Jas. Talcott, N. Y., s. agt.

**Dodgeville.** H-II. N. Y, N. H. & H. RR, Prov. Div.

HEBRON MFG Co, Dodgeville, Mill; Ste. (C) phen A. Knight, pres; Robt. Knight, treas; S. A. Knight, agt; W. H. Garner, supt; Sheetings; 10,950 ring and 15,744 mule spindles; 540 looms; water and steam; B. B. & R. Knight, Prov., s. agts. See also Hebronville, Mass, and Prov. R. I.

**Douglas.** See East Douglas.

**Dracut.** B-II. (Station Lowell.)

MERRIMAC WOOLEN MILLS. See Lowell.

**East Braintree.** E-13. N. Y, N. H. & H. RR, Plym. Div.

JENKINS MFG. Co; (P. O. address Bos. (C) ton); \$50,000; Wm. H. Gray, pres; P. Stevenson, treas; Laces, Braids, etc; 1200 braiding machines; water and steam; dye; salesroom, 97 Bedford St., Boston.

**East Brookfield.** E-8. B. & A. RR.

GIBSON, E. G; R. V. Statton, supt; Wool (W) Shoddy and Extracts; Custom Work; 5 sets; 4 pickers; steam; sell direct.

MANN & STEVEN WOOLEN Co; \$25,000; (W) Geo. Mann, pres; John P. Stevens, treas; Geo. Mann, buyer; Satinets and Unions; 4 sets; 66 looms; 1300 spindles; steam and water; dye; Lawrie, Mann & Drowne, N. Y., s. agts. (Buy cotton warp yarns, 12, 14 & 16 and small quantity of wool warp yarn in about three runs.)

MANN & STEVENS WOOLEN Co; Suit. (W) ings, Overcoatings, Skirtings and Cloakings; 4 sets; 64 looms; steam and water; Laurie, Mann & Drowne, N. Y., s. agts. (Purchased Winfield Scott & Co.'s mill.)

**East Cambridge.** (See Boston.)

**East Douglas.** G-9. N. Y, N. H. & H. RR.

HAYWARD, W. E. & Co; W. S. Schuster, (W) supt; Suitings and Union Cassimeres; 11 sets; 126 looms; water and steam; dye; Mackintosh, Taft & McKenney, N. Y. and Boston, s. agts.

**East Foxboro.** G-12. N. Y, N. H. & H. RR, Prov. Div.

BEAUMONT BROS; Fine Extracted (W) Shoddies; 3 double cylinder shoddy cards; water and steam; dye.

**Easthampton.** E-5. N. Y, N. H. & H. RR, Northampton Div, and B & M. RR, Conn, Riv. Div.

COLTON, GEO. S; Elastic Cords, Sus- (C) pendens, Garter Webs, Elastic Corset Laces, also Non-elastic and Elastic Webs for Trusses and Surgical Purposes; 100 looms; steam; sell direct.

EASTHAMPTON ELASTIC WEB Co; Her- (C) man Eger, treas; Elastic Shoe Goring; 25 looms; steam; Chadbourne & Moore, s. agts.

GLENDALE ELASTIC FABRICS Co; \$250,000; (C) Wm. G. Bassett, pres; J. W. Green, Jr, treas; George Astill, supt and buyer; Shoe Gorings, Webbing Cords, Elastic Belts, etc; 250 looms; 2000 braiders; water and steam; sell direct; offices, 66 and 68 Worth St., N. Y. (Buy 88 to 120s yarns in cotton, also silk, worsted and mercerized.)

HAMPTON COMPANY; \$100,000; F. Coit (D) Johnson, pres; Chas. E. Childs, treas; Thos. McConnell, gen'l mgr; Converters and Mercerizers Yarns; steam and water; dye.

KING SILK MILLS; A. S. King, agt; A. B. (S) King, supt; Tram, Orgazine, Fringe, Floss and Sewing Silk; 2,000 spindles; steam; dye; sell direct.

NASHAWANUCK MFG. Co; \$400,000; F. L. (C) Hine, pres; G. B. Noble, treas; Sam'l Brown, supt.; Elastic Webs and suspenders; 250 looms; water and steam; dye; sell direct; 74 Worth St., N. Y.; G. B. Noble, buyer. (Buy 10/2 to 60/2 yarns.)

WEST BOYLSTON MFG. Co; \$400,000; J. W. (C) Lane, pres; H. F. Harris, treas; Cotton Goods in variety; 50,000 spindles; 900 looms; water and steam; J. H. Lane & Co, N. Y., s. agts.

**East Webster.** G-8. In Webster, on N. Y, N. H. & H. RR.

SLATER, H. N., CAMBRIC WORKS Est. of; F. (C) Hartley, supt; Cambrics, Printed Percales and Linings; steam and water; dye; S. Slater & Sons, N. Y., Chicago, Boston and St. Louis, s. agts.

- East Weymouth.** E.B. In Weymouth, on N. Y., N. H. & H. RR, O. C. Sys.
- EAST WEYMOUTH WOOL SCOURING MILL;** (W) Wool Sorting, Scouring and Butting; steam and water.
- Enfield.** E.G. B. & A. RR.
- ENFIELD MFG. Co;** D. E. Tebo, supt; (W) Salfinets; 4 sets; 60 looms; water; dye; sell direct.
- SWIFT RIVER Co.** See Smith's.
- Essex.** C-14. B. & M. RR.
- MEARS, HENRY W;** Fish Lines; steam. (C)
- Everett.** D-13. B. & M. RR, E. Div.
- BAILEY, OSCAR L. & Co;** Silk, Wool and (K) Worsted Mittens and Gloves, for Men, Women and Children; 100 knitting machines; steam; sell direct; 18 Kingston St, Boston; Oscar L. Bailey, buyer. (Buy woolen, worsted, silk and mercerized yarns.)
- COLUMBIA MFG. Co.;** Wm. J. Buckley, (C) mgr.; Cotton Clothes Lines and Cordage.
- PURITAN KNITTING MILLS;** Oscar L. Bai. (K) ley & Co; Ladies' and Children's Jersey Ribbed Underwear; 40 knitting machines; steam; sell direct; office 18 Kingston St., Boston. (Buy cotton and lisle yarns, single and 2 ply, and worsted, black and white, single.)
- Fall River.** J-12. N. Y., N. H. & H. RR. Tamm. Div.
- ALGONQUIN PRINTING Co;** \$160,000; R. (Pr) T. Davis, pres; Wm. H. Jennings, treas; Jas. A. Chadwick, supt, and buyer; Indigo Blues and Aniline Blacks, Shirtings and Chocolate prints; steam; dye; New York office, 47 Worth St.
- AMERICAN LINEN Co.;** FETTY ST., \$800,000; (C) John S. Brayton, pres.; J. E. Osborn, treas., John A. Collins, supt; Print Cloths and Kindred Fabrics; 52,736 ring and 40,264 mule spindles; 2250 looms; steam; sell direct.
- AMERICAN PRINTING Co;** \$750,000; M. C. (Pr) D. Borden, pres; (N. Y. C.) B. H. Borden, treas; (N. Y. C.) Jas. B. Harley, agt, supt, and buyer; Printed Calicoes, Indigos, Blacks, Greys, Shirtings; 19 machines; steam and water; dye; Bliss, Fabyan & Co., N. Y., Boston and Phila., s. agts.
- ARKWRIGHT MILLS;** \$450,000; Joseph A. (C) Bowen, pres; John P. Bodge, treas, and agt; C. C. Pierson, supt; Odd Goods and Specials; 53,408 ring spindles; 1,403 looms; steam; sell direct.
- BARNABY MFG. Co.;** \$400,000; Jerome (C&S) C. Borden, pres.; Arthur H. Mason, treas, and agt.; Wm. P. Holt, supt.; Fine Colored Cotton Goods and Yarns, also Silk Novelties; 16,912 ring spindles; 750 looms; steam; dye; Clarence Whitman & Co., N. Y., s. agts.; also sell direct; 69 Worth St., N. Y.
- BARNARD MFG. Co;** \$495,000; Bradford (C) D. Davol, pres; N. B. Borden, treas, and agt; Wm. Hathaway, supt; Cotton Cloth, Plain, Twill and Fancy Weaves, average 33 yarns, 54,256 ring and 8,680 mule spindles; 1795 looms; steam; sell through brokers; N. B. Borden, buyer.
- BOLTON MFG. Co;** (P. O. Box 198.) Leno, (C) Lappet and Whipnets; Fancy Weaves of all kinds; 25 looms; steam.
- BORDEN MFG. Co., RICHARD;** Rodman St., (C) \$800,000; Thos. J. Borden, pres.; R. B. Borden, treas.; Alexander Makpence, supt.; Print Cloths, Plain and Fancy Weaves; 57,392 ring and 31,060 mule spindles; 2350 looms; steam; sell direct; R. B. Borden, buyer.
- BORDER CITY MFG. Co.;** No. Main St.; (C) \$1,000,000; John S. Brayton, pres.; E. L. Anthony, treas.; G. P. Cattle, supt.; Print Cloths, Sheetings, Shirtings, etc.; 80,768 ring and 39,044 mule spindles; 2337 looms; steam; sell direct.
- BOURNE MILLS;** Laurel Lake; \$400,000; S. (C) A. Jenks, pres.; Geo. A. Chace, treas and agt.; R. Murray, supt.; Twills, Satcens and Odd Goods; 16,800 mule and 68,008 ring spindles; 2,743 looms; steam; sell direct. Geo. A. Chace and R. Murray, buyers. (Buy warp on beams, 32/1, 36/1, and on tubes, 30/2, 32/2).
- CHACE MILLS;** Rodman St.; \$750,000; Edw. (C) E. Hathaway, pres.; J. A. Baker, treas, and agt.; John C. Smith, supt.; Print Cloths, Plain and Twilled Wide Goods; 80,416 ring spindles; 1902 looms; steam; sell direct; John C. Smith, buyer supplies.
- CONANICUT MILLS;** \$120,000; E. W. Con (C) verse, pres; C. E. Lindsey, treas, and agt; C. A. Brown, supt; Wide Fine Goods; 12,352 ring and 5,852 mule spindles; 444 broad looms; water and steam; sell direct.
- CONGDON, GEORGE;** Blossom Ave; (C) Scrims, Fancy Cottons, also Twines, etc; 22 looms; steam; Grinnell, Willis & Co, N. Y., s. agts.
- CORNELL MILLS;** Alden St; \$400,000; John (C) D. Flint, pres; F. E. Waterman, treas; F. S. Akin, supt; Cotton Goods; 41,920 ring spindles; 1080 looms; steam; sell direct; F. S. Akin, buyer.
- CRESCENT HAT Co;** (successors to (W) Pocasset Hat Co); \$25,000; John H. Estes, pres; Wm. Marshall, treas; Soft Fur Hats; steam; dye; Taylor & Seeley, N. Y., s. agts.
- CRYSTAL SPRING DYEING & (Bl, Pr & D) BLEACHING Co;** \$125,000; Wm. Fish, Jr., pres; W. N. McLane, treas; James Crossley, agt and supt; Dyers, Bleachers and Printers; Cotton Goods; steam; W. N. McLane, buyer. Freight address, Assonet.
- DAVIS MILLS;** \$500,000; Lcontine Lincoln, (C) pres ; J. B. Richards, treas, and agt.; 40s to 100s yarn made into Fine and Fancy Cotton Goods; 49,320 ring spindles; 800 looms; sell direct; J. B. Richards, buyer. (Expect to start Jan., 1903.)
- DAYOL MILLS;** Hartwell St; \$400,000; (C) Frank L. Fish, pres; Geo. H. Hills, treas, and agt; Timothy Sullivan, supt, and buy r; Sheetings, Twills, Satcens and Oil Cloth Goods; 18,448 mule and 26,496 ring spindles; 1260 looms; steam; Clarence Whitman & Co, N. Y., s. agts; also sell direct.
- DURFEE MILLS;** Pleasant St.; \$500,000; (C) John S. Brayton, pres; David A. Brayton, Jr, treas; J. H. Potter, Jr, supt; Print Cloths, Wide Cloths, Odd Goods; 117,216 mule and 116,032 ring spindles; 3482 looms; steam; sell direct and through brokers.
- ESTES, J. H. & SONS;** John H. Estes, (C) pres; J. Edmund Estes, treas; E. B. Estes, supt; Cotton Twines, Warps, Yarns, Rops, Ropes, Clothes Lines, Wiping Waste, Cankling Cotton, and Absorbent, Bleached and Tinted Cottons; 208 braiders; 221 cards; water and steam; dye; sell direct and through agents.
- FALL RIVER BLEACHERY Co;** \$600. (Bl & F) 000; Spencer Borden, pres; Spencer Borden, Jr, treas, agt and supt.; Geo. O. Lathrop, sec.; Bleachers and Finishers; steam; Spencer Borden, Jr., buyer.
- FALL RIVER BRADING Co;** 29 Bowens St.; (C) Geo. H. Read, mgr.; Cotton Braids; 75 braiders. (Buy 20.2 skein yarn.)
- FALL RIVER IRON WORKS Co;** FETTY ST., (C) \$2,000,000; M. C. D. Borden, pres; Wm. J. Harley, treas; James B. Harley, agt; S. E. Hathaway, supt; Print Cloths; 266,512 spindles; 7660 looms; steam; sell direct; S. E. Hathaway, buyer. (To build another mill of not less than 80,000 spindles.)
- FALL RIVER MANUFACTORY;** Pocasset St.; (C) \$240,000; John S. Brayton, pres; W. F. Shove, treas; Thos. F. Connors, supt;

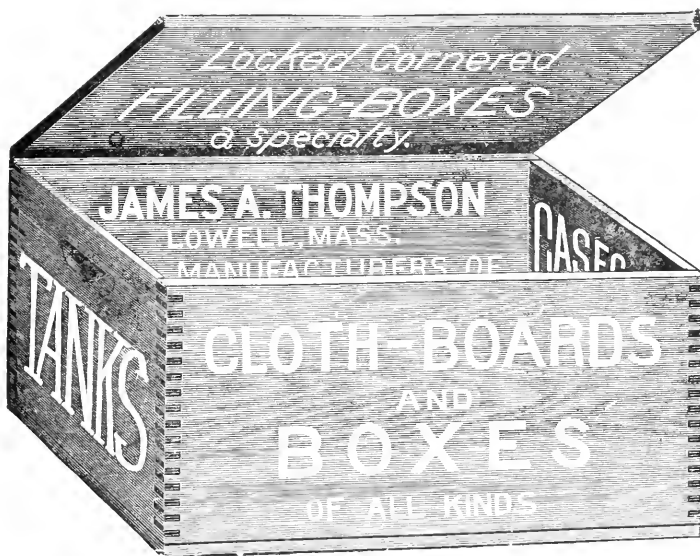

Print Cloths; 36,784 ring spindles; 1045 looms; water and steam.

**FLINT MILL;** Alden St.; \$580,000; J. D. Flint, pres; W. S. Potter, treas. and agt; Charles H. Shaw, smpt.; Cotton Goods to order; 50,816 spindles; 1164 loom; steam; sell through brokers; W. S. Potter, buyer.

**GLOBE YARN MILLS** (New England Cot. (Cotton Yarn Co.); 460 Globe Ave; Yarns, Threads and Hosiery Yarns; steam. Sell from New Bedford office, which see for officers.

**Goss Bros;** 1467 Bedford St; Cotton (C) Banding, Harness Twines, Clothies Limes; steam; sell direct.

**GRANITE MILLS;** Two 1/2 St.; \$1,000,000; (C) John S. Brayton, pres; C. M. Shove, treas. and agt; Thomas H. McCreery, smpt; Prints, Cloths and Twills; Fancy Goods; 121,312 spindles; 3040 looms; steam; sell direct.

**HARGRAVES MILLS;** Jefferson St.; \$800,000; L. Lincoln, pres; Seth A. Borden, treas; Arthur M. Hamilton, smpt; Fine Cotton Goods; 71,660 ring and 24,888 mule spindles; 3154 looms; steam; sell direct.

**HEYWOOD NARROW FABRIC CO.** (for C) merly M. Heywood & Co.); 264 So. Main St; P. O. Box 714; \$27,500; John J. Heywood, pres. and smpt.; Charles H. Duffee, treas; Cotton Banding, Spool Braids, Corset and Shoe Laces and Braids for Trimmings; 1050 braiders; electric power; dye; sell direct; treas. and mgr. buyers.

**HOLDEN, JAS;** 559 Ridge St; Cotton Rope, (C) Banding, Cotton Twine of All Kinds; 250 ring spindles; steam; sell direct. (Buy all kinds yarn.)

**KERR THREAD CO;** Kerr St.; (American (C) Thread Co); J. P. Kerr, pres; R. C. Kerr, treas; I. C. Davis, sec; Fine Cotton Yarns and Spool Thread; 54,000 spindles; steam; dye; Am. Thread Co, N. Y., Boston and Phila., s. agts.

**KING PHILLIP MILLS;** 372 Kilburn St.; (C) \$1,000,000; Chas. J. Holmes, pres; S. B. Chase, treas. and agt; P. A. Mathewson, smpt; Fine Cotton; 56,544 mule and 63,760 ring spindles; 3900 looms; steam; W. L. Wellington, N. Y., s. agt.

**LAUREL LAKE MILLS;** Broadway; \$300,000; John P. Slade, pres; A. E. Slade, treas. and agt; Timothy Sullivan, smpt; Print Cloths and Wide Goods and Odds; 43,040 ring and 14,400 mule spindles; 1628 looms; steam; sell direct.

**LEWIS, N. & N. R.;** Shaw St.; Cotton (C) Waste; 3 pickers.

**MAPLEWOOD MILLS;** John H. Estes, (C) pres; J. Edmund Estes, treas; E. B. Estes, smpt; Absorbent, Bleached and Tinted Cottons; 40 cards; dye house and bleachery; steam; sell direct.

**MASSAHOIT MFG Co;** 156 Davol St.; \$150,000; Frank L. Palmer, pres; Wendell E. Turner, treas. and agt; Cotton Waste, Wick Yarns, Mops and Wiping Waste; steam; sell direct, 56 Leonard St., N. Y.; W. E. Turner, buyer. Also mills in Oakdale, Ct.

**MECHANICS MILLS;** 1084 Davol St.; \$750,000; (C) T. J. Borden, pres; Edw. Shove, treas. and agt; Felix Crankshaw, smpt; Cotton Goods on order; 40,608 ring and 17,248 mule spindles; 1551 looms; steam; sell direct; Edw. Shove, buyer.

**MERCHANTS' MFG. Co;** 14th and Bedford (C) Sts.; \$800,000; Edw. B. Jennings, pres; James E. Osborne, treas; Geo. H. Law, smpt; Print Cloths and Kindred Fabrics; 44,280 mule and 90,352 ring spindles; 3324 looms; steam; sell direct.

**METACOMET MFG Co;** 172 Abnawan St.; (C) \$288,000; John S. Brayton, pres; W. Frank Shove, treas. and agt; Thos. Connors, smpt; Prints and Odds; 28,532 spindles; 794 looms; steam; sell direct.

**NARAGANSETT MILLS;** 1567 No. Main St.; (C) \$400,000; Edward S. Adams, pres; Isaac A. Brown, treas; Jabez Wilkinson, smpt; Print Cloths, Satens, Corset Jeans, Twills and Alberts; 28,532 ring and 14,688 mule spindles; 1227 looms; steam; sell direct; Isaac A. Brown and John Harrison, buyers.

**OSBORN MILLS;** Tower St.; \$750,000; John (C) C. Milne, pres; Simon B. Chase, treas. and agt; J. Watters, smpt; No. 1 Mill, Odds, Satens and Nainsooks in coarse grades;

- No. 2 Mill, Fine Goods, Sateens, Lawns and Nainsooks; 49,696 ring, 22,680 mule spindles; 1848 looms; steam; sell direct.
- PARKER MILLS;** \$800,000; Jefferson St.; L. (C) Lincoln, pres; Seth A. Borden, treas; A. M. Hamilton, supt; Fine Cotton Goods; 25,568 ring and 23,400 mule spindles; 1208 looms; steam. (See also Warren, R. I.)
- POCASSET MFG. CO;** Pocasset St.; \$600,000; (C) T. E. Brayton, pres; W. F. Shove, treas. and agt; Wm. A. Nichols, supt; Sateens, Twills and Plain Cloths; 77,220 spindles; 1951 looms; water and steam; Converse, Stanton & Co, N. Y. and Boston, s. agts.
- ROBESON MILLS;** 240 Hartwell St.; \$260. (C) 000; Chas. B. Luther, pres; Horace Tinkham, treas. and supt; Print Cloths; 23,712 ring spindles; 660 looms; steam; sell direct.
- SAGAMORE MFG. CO;** No. Main St.; \$900,000; (C) Chas. J. Holmes, pres; H. A. Brayton, treas.; James A. Burke, Jr., supt; Print Cloths; 69,560 ring and 21,112 mule spindles; 2380 looms; sell direct.
- SANFORD SPINNING CO.** (New England (C) Cotton Yarn Co) Globe Mills St.; Yarns; steam; dye; sell direct from New Bedford office which see for officers.
- SEACONNET MILLS;** East Warren St.; \$600, (C) 000; Leontine Lincoln, pres; E. A. Chace, treas; J. E. Cuncen, supt; Print Cloths; 65,288 ring spindles; 1848 looms; steam; Edw. A. Chace, s. agt.
- SHOVE MILLS;** \$550,000; 126 Shove St.; Isaac (C) W. Howland, pres; C. C. Rouseville, treas; Edward Lynch, supt; Print Cloths and Odds; 59,456 ring and 11,232 mule spindles; 2500 looms; steam; sell direct; C. C. Rouseville, buyer.
- SLADE MILLS;** \$200,000; Globe St.; Freder. (C) ick Beebe, pres; H. S. Fenner, treas. and agt; Dan. J. Harrington, supt; Print Cloths, Sateens and Specialties; 21,344 ring and 21,352 mule spindles; 1073 looms; steam; sell direct; treas. and supt, buyers.
- SMALL BROS;** 519 Prospect St.; E. W. (C) Small, supt.; Banding, Ropes, Braids, Clothes Lines, Tubular Braids and Spool Braids; 1300 braiders; electric power and gas; sell direct and Am. Braiding Co. for Spool Braids; R. C. Small, Jr., buyer. (Buy 10/1 to 30s in warps, 12/2 to 30/2 skeins and tubes.)
- STAFFORD MILLS;** County St.; \$1,600,000; (C) R. T. Davis, pres; Frederick E. Waterman, treas. and agt; S. W. Hathaway, supt; Print Cloths; 74,464 ring and 22,632 mule spindles; 2623 looms; steam; sell direct; F. E. Waterman, buyer.
- STEVENS MFG. CO;** Russell St.; \$350,000; (C) S. B. Chase, pres; Geo. H. Hills, treas. and agt; Thos. McAuliffe, supt; Marseilles and Crochet Quilts; 8000 ring spindles; 114 looms; steam; bleachery; Clarence Whitman & Co., N. Y., s. agts. Building new mill.
- SWANSEA DYE WORKS;** Davol St.; (D&P) \$10,000; F. L. Palmer, pres; W. E. Turner, treas. and agt; Richard Booth, supt.; dye and print Cotton Piece Goods; steam and water. (Works at Swansea.) W. E. Turner, buyer.
- TECUMSEH MILLS;** 169 Hartwell St.; \$500. (C) 000; J. C. Borden, pres; Frank H. Dwellley, treas. and agt; Robinson Walmesley, supt; Odd Goods to Order; 52,976 ring and 23,776 mule spindles; 1756 looms; steam; sell direct
- TROY COTTON & WOOLEN MFG. CO;** Troy (C) St.; \$300,000; J. S. Brayton, pres; R. B. Borden, treas; Wm. E. Sharples, supt; Cotton Cloths, various widths and counts; 25,248 ring and 21,714 mule spindles; 1659 looms; water and steam; sell direct; R. P. Borden, buyer.
- UNION COTTON MFG. CO;** Pleasant St.; (C) \$1,200,000; E. L. Anthony, pres; Thos. E. Brayton, treas.; John Sullivan, supt; Print Cloths and Wide Goods; 64,848 ring and 46,240 mule spindles; 2859 looms; steam; sell direct.
- WAMPANOAG MILLS;** Quequechan St.; (C) \$750,000; Robt. T. Davis, pres; Wm. Evans, treas. and agt.; Timothy Mooney, supt.; Print Cloths, Wide Goods, Twills, Sateens and Fancies; 59,762 ring and 33,152 mule spindles; 2167 looms; steam; sell direct.
- WEETAMOG MILLS;** 1290 Davol St.; \$550,000; (C) Geo. H. Eddy, pres; E. J. French, treas; R. Thackeray, supt; Print Cloths; 21,856 ring and 23,820 mule spindles; 1176 looms; steam; sell direct; E. J. French, buyer.
- WESTPORT MFG. CO;** W. C. Trafford, (C) treas; Wm. E. Sherman and Wm. E. Manchester, supts; Carpet Warps, Batts, Lamp Wicking, etc. and Cotton Twines; 5000 spindles; water and steam; sell direct. William C. Trafford, and Geo. W. Lewis, buyers. Mills at Westport. (Also dealers in Cotton Waste.)
- Farley.** C-6 Fitch RR.
- ORANGE KNITTING CO;** Farley & Ruffle; (K) Mittens and Gloves; 50 knitting machines; water; sell direct. (Branch mill at Shelburne Falls.)
- Fisherville.** F-9. Station Farmum's, on N. Y. N. H. & H. RR, Wor. Div.
- FISHER MFG. CO;** \$500,000; Oliver Ames, (C) pres; M. U. Adams, treas; A. W. Dimick, supt; Cotton Fancies; 16,000 ring and 21,000 mule spindles; 819 looms; water and steam; Wheelwright, Eldredge & Co, N. Y, Boston and Phila, s. agts.
- Fiskdale.** F-7. Electric cars from South-bridge, on N. E. RR, and stage from Brookfield, on B. & A. RR.
- FISKDALE MILLS;** Frederick D. Fisk, (C) pres; Franklin D. Williams, treas; John Gregson, supt, agt. and buyer; Print Cloths and Specialties; 16,328 ring and 18,232 mule spindles; 84 looms; water and steam; F. D. Williams, 87 Milk St, Boston, s. agt. and buyer.
- Fitchburg.** C-9. Fitch RR; N. Y, N. H. & H. RR, O. C. System, Nor. Div.
- ASHURNHAM SHEETING MILL;** Sam'l A. (C) Clough, treas; Thos. C. Sheldon, agt; Cotton Yarns; 512 ring spindles; water; sell direct; Thos. C. Sheldon, buyer. Mill at Ashburnham
- BARTOW & COOKSON;** 413 River St.; Cotton (C) and Wool Waste and Batting; 35 cards; water and steam.
- BEOLI MILLS;** (American Woolen Co.); (W) Wm. M. Wood (Boston), treas; John Shireffs, agt; Worsted Suitings and Overcoatings; 10 sets; 230 looms; steam; dye; J. C. Woodhull, N. Y, s. agt.; H. J. Potter (Boston), buyer.
- FITCHBURG DUCK MILLS;** S. A. Clough, (C) treas; Thos. C. Sheldon, agt; Duck; 4,350 ring spindles; 42 looms; water and steam; Samuel A. Clough, 78 hauney St., Boston, s. agt.; Thos. C. Sheldon, buyer. (Buy 6½ and 8½ yarn on tubes.)
- FITCHBURG WORSTED MILLS;** (Ameri (W) can Woolen Co.); W. M. Wood, (Boston), treas; John Shireffs, agt; John Leiper, supt; Suitings, Trouserings, Coverts and Whip Cords; 188 broad and 17 narrow looms; steam and water; J. C. Woodhull, N. Y, s. agt; H. J. Potter, (Boston) buyer.
- GRANT YARN CO;** \$200,000; Rodney Wal. (C) lace, pres; Geo. P. Grant, Jr, treas; W. E. Keach, supt; Carded and Combed Cotton Yarns, No. 40s to 80s; 31,232 ring spindles; steam; sell direct; Geo. P. Grant, Jr., buyer.
- NOCKEGE MILLS;** 273 River St.; \$300,000; C. (C) T. Crocker, pres.; W. F. Stiles, treas.; Print Cloths and Fancy White Goods; 28,000 ring spindles; 620 looms; steam; sell direct; W. F. Stiles, buyer.

ORSWELL MILLS; River St.; \$300,000; C. T. (C) Crocker, pres.; W. F. Stiles, treas.; Carded and Combed Cotton Yarns, Peeler and Egyptian; 37,000 ring and 7,000 mule spindles; steam; sell direct; W. F. Stiles, buyer.

PARKHILL MFG. CO.; \$300,000; (Inc. 1881); (C) John Parkhill, pres. and supt.; A. H. Lowe, treas. and agt.; "Toile du Lord" Fabric and Fine Dress Goods; 2200 looms; steam and water; dye; Fred'k Victor & Achelis and J. Harper Poor Co., N. Y., Chicago and Boston, s. agts.; Arthur H. Lowe, buyer. (Buy yarns.)

STAR WORSTED CO.; \$50,000; C. T. (W) Crocker, pres.; C. B. Smith, treas. and agt.; A. Garth, supt.; Worsted Yarns; 9 sets; 7 combs; 4500 spindles; steam and water; sell direct.

SUN MILLS MFG. CO.; \$95,000; Peter H. (C) Corp, pres.; Geo. T. Hoffman, treas.; C. W. Corkran, agt.; Cotton Cordage, Wick and Twine; steam and water; dye; sell direct. (Operating old Glen Woolen Mill at West Fitchburg.)

**Florence.** E-4.

NONOTUCK SILK CO.; Corticelli Silk mills; (\$1,000,000; Ira Dimock, pres.; Geo. H. Ray, treas.; Spool Silk, Machine Twist, Sewing Silk, Knitting Silk, Silk Mittens and Underwear, Silk Braids and Spun Silk on Cones and Tubes for Manufacturers' use, Also Worsted and Mohair Dress Braids, Trimming Braids and Bindings; water and steam; dye; Geo. H. Ray, buyer. Offices in Boston, N. Y., Gloversville, Philadelphia, Cincinnati, Chicago, St. Paul and San Francisco. Also Leeds and Haydenville, Mass.

**Forge Village.** C-10. See Graniteville

**Foxboro.** G-12. See East Foxboro

**Framingham.** E-11. See Saxtonville.

**Franklin.** F-11. N. Y., N. H. & H. RR.

AMERICAN FELT COMPANY; Franklin (W) Mill; E. Waite, supt.; Saddlery Felts, Felt Linings, Shoe Felts and Horse Blankets; 28 cards; water and steam; dye; sell direct. (See New York City for officers.)

CHARLES RIVER WOOLEN CO.; Geo. E. (W) Duffy, agt.; C. Fitzgerald, supt.; Shoddy Mill; 8 pickers; 2 garnett machines; 25 cards; steam. (Branch of plant at No. Bellingham.)

FRANKLIN YARN MFG. CO.; Herbert W. (W) Thayer, treas.; Cotton, Woolen and Merino Yarns; 4 sets; 232 spindles; steam; dye; sell direct and Andrew J. Solis, Jr. and Solis & Co, Boston, s. agts. H. W. Thayer, buyer.

HAYWARD, H. T.; Hayward Mills; L. W. (W) Stott, supt.; Cotton Warp Suitings and Coatings; 6 sets; 102 looms; steam; dye; Mackintosh, Taft & McKenney, Boston and N. Y., s. agts.

NORFOLK WOOLEN CO.; \$50,000; H. P. (W) Ray, pres.; B. M. Rockwood, treas.; Wool Shoddies and Extracts; 31 cards; 1 Garnett machine; steam and water; dye; sell direct; B. M. Rockwood, buyer.

PENDERGAST, DANIEL; William Pender. W agt. mgr.; Shoddy. (Mill at South Franklin.)

RAY FABRIC MILLS; Norfolk Woolen (W) Co.; props; H. P. Ray, pres.; B. M. Rockwood treas.; W. A. Clark, supt.; Horse Blankets and Linings; 2 sets; 20 sewing machines; water and steam; dye; sell direct; W. A. Clark, buyer.

RAY MILLS (American Woolen Co.) W. (W) M. Wood, (Boston), treas.; Fred P. Chipman, agt.; Fancy Woolens; 8 sets; 56 looms; steam; dye; J. C. Woodhull, N. Y., s. agt.; H. J. Potter (Boston) buyer.

SINGLETON WORSTED CO.; \$75,000; Her. (W) herf Lawton, pres.; Geo. F. S. Singleton, treas. and supt.; Worsted Cloth for Men's and Children's Suitings; 52 looms; steam;

dye; sell direct; Geo. F. S. Singleton, buyer. (Buy worsted yarns from finish grade to the medium as also & Blood.)

WORCESTER TEXTILE CO. formerly (C & F) at Worcester; \$50,000; Wm. Wattle, pres.; W. H. Tyler, treas.; B. Laycock, supt.; Linen, Union and Turkish Towels; 103 looms; steam; W. H. Burgess & Co., N. Y., s. agts., (P. O. address Unionville.)

**Gilbertville.** E-7. See Ware.

**Gleasondale.** D-10. B. & M. RR; Fitch, RR.

GLEASON, A. D.; P. Feather, supt.; (W) Ladies' Dress Goods; 9 sets; 54 looms; water and steam; dye; J. P. Stevens & Co, s. agts.; A. D. Gleason, buyer.

**Globe Village.** F-8. In Southbridge. N. Y. & N. E. RR.

HAMILTON WOOLEN CO.; \$1,000,000; (C & W) C. Merriam, pres.; C. A. Coleman (Boston), treas.; C. W. Hill, agt.; Cassimeres and Ladies' Dress Goods, Worsted; 13 woolens sets; 27 worsted sets; 42 woolen looms; 920 worsted looms; 12 combs; 15,000 cotton spindles; water and steam; dye; Joy, Langdon & Co, Boston and N. Y., s agts. Mills also at Amesbury, Mass.

**Gloucester.** C-14. B. & M. RR. E. Div, and B. & G. Stmbt. Co.

BURNHAM, L. A. & Co; Cotton Fish (C) Lines; steam; sell direct; L. A. Burnham, buyer. (Buy 8 and 10 yarn on beams.)

GLOUCESTER NET AND TWINE CO.; \$175,000; (C) Geo. A. Smith, treas.; M. N. Rice, supt.; Fish Nets and Twines; 12 frames; 200 spindles; steam; sell direct; 46 Clinton St., Boston.

**Grafton.**

See North Grafton and Fisherville.

**Graniteville.** C-10. B. & M. RR, So. Div, Stony Brook Branch; and Acton Branch of B & M., Worcester, Nashua and Rochester Div.

ABBOTT WORSTED CO.; \$600,000; J. A. (W) Cameron, pres; A. J. Abbott, treas. and buyer; J. C. Abbott, agt., Graniteville; J. A. Cameron, agt., Forge Village; John Gray, supt. woolen and Henry Smith, worsted, at Graniteville; Frank Hindle, supt., Forge Village; Carpet, Woolen and Worsted Yarns, (Bradford system); 22 combs; 1 set woolens; 7 sets worsted; 15,624 worsted spindles; 7 sets preparers; steam and water; J. C. Wallace, Phila., s. agt. and sell direct. Mill also at Forge Village.

**Great Barrington.** F-1. N. Y., N. H. & H. RR, Berk. Div.

ENDRICK WOOLEN MILLS; 16 sets; 75 (W) looms. *Not running.* (Hugh Sheridan moved to Ashuelot, N. H.)

MONUMENT MILLS. See Housatonic.

RIVERDALE MILLS; \$100,000; Wm. L. (C) Brown, pres.; E. D. Smith, treas.; Marcellines and Crochet Quilts, Cotton Towels; 77 looms; steam; Quander Walsh Co., N. Y., s. agts. Buy 12 2 1/2, 10 2, 14 1, 8 1, 9 2; 8 2 warps and 8 2 and 9 2 on cones.)

**Griswoldville.** C-1. Electric St. RR, Shelburne Falls to Griswoldville, on Fitch, RR.

GRISWOLDVILLE MFG. CO.; \$125,000; E. D. (C) Griswold, pres.; Joseph Griswold, vice-pres.; Lorenzo Griswold, treas.; F. D. Griswold, agt.; M. A. Leavitt, supt.; Buntings, Supers, Interlinings and Bleached Gauze and Butter Cloths; 9000 ring and 8000 mule spindles; 422 looms; water and steam; bleach; sell direct, 51 Leonard St, N. Y. (Buy warp 30/4 filling No. 40 cop).

**Groveland.** See So. Groveland.

**Hampden.** G-6. Stage 6m at E. Longmeadow on N. Y. & N. E. RR.

- KENWORTHY, JOHN;** Cotton Worsteds (**W**) and Horse Blankets; 4 sets; 22 looms; water and steam; dye. *Assigned Feb. 02.*
- HAMPDEN MILLS CO.;** \$15,000; D. N. (**W**) Brown, pres.; James Graney, treas.; Cassimeres and Overcoatings; 4 sets; 21 looms; steam and water; dye.
- Haverhill.** B-12. B. & M. RR, W. Div.
- STEVENS & CO.;** See M. T. Stevens & (**W**) Sons Co., No. Andover; Geo. W. Engel, supt.; Dress Goods; 12 sets; 112 looms; 4980 mule spindles; water and steam; dye.
- THOM, W. B. & CO.;** C. R. Thom, supt.; (**W**) Fur Hats; steam; dye; Thom & Bayley, 17 Washington Pl., N. Y., s. agts.
- Hebronville.** H-11. N. Y., N. H. & H. RR, Prov. Div.
- HEBRON MFG. CO.;** Hebron Mill; S. A. (**C**) Knight, pres.; Robt. Knight, treas.; S. A. Knight, agt.; A. MacWhinnie, supt.; Fine Cotton and Hosiery Yarns; 20,000 ring and 5,200 mule spindles; water and steam; sell direct. E. C. Fuller, Prov. buyer. Also Dodgeville and Prov.
- Highlandville.** E-12. N. Y., N. H. & H. RR. See also Needham.
- BROOKS, JOHN F. CO.;** \$25,000; Stephen (**K**) Bowen, pres.; Timothy W. Hoxie, treas.; W. S. Drowne, supt.; Infants Knit Shirts, Mittens and Bands; 50 knitting machines; steam; sell direct.
- CARTER, WM., CO.;** Wm. Carter, mgr.; (**K**) Children's, Misses' and Ladies' Underwear and Mittens, Cotton, Worsted and Silk; Children's Stockings, Men's and Ladies' Union Suits, Knit Specialties; 65 knitting machines; 50 sewing machines; steam; dye; sell direct.
- GORSE, F. W.;** Surgical Elastic Goods; 6 (**K**) knitting and 3 sewing machines.
- GORSE, WM. & CO.;** Silk and Cotton (**K**) Surgical Elastic Goods; 5 hand knitting machines; sell direct.
- GRAVES FRANK, (formerly Mrs. Anne (K) Hall);** Infants' and Children's Mitts; 8 hand knitting machines; O. L. Bailey & Co., Boston, s. agts.
- LANGDALE, JOS.;** Boys' and Men's (**K**) Woolen Gloves; 10 hand knitting machines; sell direct.
- LATHAM, FRED.;** Ladies' and Mens' (**K**) Gloves; 8 knitting machines; sell direct.
- MOSELEY & CO.;** Highland Mill; (**K**) Ladies' and Children's Fine Ribbed Underwear, Vests, Corset Covers; and Ladies' Golf Gloves; 60 knitting machines; steam; sell direct. (Buy worsted, cotton and silk yarn.)
- ROPER BROS. & CO.;** Athletic Knit (**K**) Goods, Wool, Worsted and Silk; 45 knitting machines; 30 sewing machines; steam; dye; sell direct; Wm. Roper, buyer.
- THORPE, J. B.;** Mittens and Underwear; (**K**) 28 knitting machines; sell direct. (Buys worsted, 1/30 to 1/60 and cotton, 1/22 to 50.)
- WALKER, GEO.;** Cotton and Silk Elastic (**K**) Hose; 5 knitting machines; steam; sell direct.
- WILSON, SAMUEL.;** Woolen Gloves and (**K**) Infant's Mitts; 5 hand frames; sell direct.
- Hingham** E-13. N. Y., N. H. & H. RR, O. C. N.Y.
- DOWER, JAMES & SON.;** \$1000; Thomas B. (**F**) Dower, supt.; Linen, Cotton, Jute and Hemp lines.
- Hinsdale.** D-2. B. & A. RR.
- HINSDALE WOOLEN CO.;** \$83,000; F. W. (**W**) Hinsdale, pres.; Jas. H. Hinsdale, treas.; Peter A. Clogher, supt.; and buyer; Beavers, Fancy Cassimeres, and Kerseys, 16 sets; 82 looms; water and steam; dye; Schnabel Bros.; N. Y., s. agts.
- Holden.** E-9. Fitch. RR. See also Jefferson and Quinapoxet.
- DAWSON MFG. CO.;** \$20,000; Chas. Daw- (**W**) son, pres. and treas.; C. A. Dawson, supt.; Piece-Dyed Tibets; 6 sets; 24 looms; steam; dye; Oelbermann, Donnerich & Co., s. agts.; Charles and Chas. A. Dawson, buyers. (Also Holliston.)
- Holliston.** F-11. B. & A. RR.
- HOLLISTON MILLS.;** Dawson Mfg. Co.; (**W**) 6 sets. (See also Holden, Mass.)
- Holyoke.** F-5. B. & M. RR, Conn. Riv. Div., N. Y., N. H. & H. RR, Northampton Div.
- AMERICAN QUILT CO.;** *Out of business.* Plant sold to Palmer Bros., Conn.
- BEEBE, WEBBER & CO.;** Men's Wear, (**W**) Woollens and Worsteds; 8 sets; 110 looms; water; dye; Fleitmann & Co. and James Talcott, s. agts.; Messrs. Beebe & Webber, buyers. (Also branch at Spencer.)
- CRESSY THREAD CO.;** Geo. W. Cressy, (**C**) pres.; James Barnes, treas.; Chas. N. Cressy, agt. and supt.; Thread of all kinds; water; sell direct and The H. B. Claffin Co., N. Y. and N. H. Bullock & Co., s. agts. (Buy all grades in thread yarns.)
- FARK ALPACA CO.;** \$400,000; E. W. Chapin, (**W**) pres.; Joseph Metcalf, agt. and treas.; Worsted Dress Goods; 14 combs; 900 looms; water and steam; dye; Thomas B. Martin, N. Y. Boston, and Phila. s. agt.; Joseph Metcalf, buyer. (Buy cotton warps.)
- GERMANIA MILLS.;** \$150,000; Herman (**W**) Stursberg, N. Y. pres.; W. Stursberg, treas.; W. Mauer, agt.; G. Steinberg, supt.; Overcoatings, Cloakings and Beavers; 18 sets; 83 looms; steam and water; dye; Stursberg, Schell & Co.; N. Y., s. agts.
- GOETZ SILK MFG. CO.;** \$35,000; David (**S**) Goetz, pres.; Sam'l McQuaid, treas.; David Goetz, supt.; Satin Linings; 125 looms; steam and water; sell direct; 695 Broadway, N. Y.; Sam'l McQuaid, buyer.
- GROSVENOR WOOLEN CO.;** \$20,000; W. (**W**) J. Stritche, pres.; Chas. F. Grosvenor, treas.; Shoddies, Wool Extracts, Floeks; 7 sets; steam and water; dye; sell direct. (See Palmer, Mass.) (Operating Connor Bros. mill, purchased.)
- HADLEY CO. (Am. Thread Co.);** R. C. Kerr, (**C**) pres.; E. A. Still, treas.; Spool Cotton, Shoe Thread, Harness and Seine Twines, and Fine Warps; 48,112 ring and 13,408 mule spindles; water and steam; Am. Thread Co., N. Y., Boston, Phila. s. agts.
- HOLYOKE PLUSH CO. (formerly Chad (W) wich Plush Co.);** \$50,000; E. M. Goodall, pres.; Frank Hopewell, treas.; D. Chadwick, agt.; Jno. Chadwick, supt.; Velours, and Plush Lap Robes; 4 sets; 32 looms; water and steam; dye; L. C. Chase & Co., Boston, s. agts.
- HOLYOKE THREAD CO., Winter St.;** (**D & F**) \$15,000; John E. Brown, pres.; Robert Hunter, treas. and buyer; Finishing of Silk, Cotton, Linen and Mercerizing Thread.
- HOLYOKE WARP CO.;** \$60,000; James Ren- (**C**) frew, pres.; J. L. Burlingame, treas. and mgr.; Warps and Yarns; 6,272 ring spindles; steam and water; dye; sell direct.
- LYMAN MILLS.;** \$1,475,000; T. Parsons, (**C**) treas.; Ernest Lovering, agt.; Chas. Merriam, supt.; Sheetings, Drills, Carded and Combed Lawns and Fancies; 71,000 ring and 39,000 mule spindles; 2400 looms; steam and water; Mmot, Hooper & Co., N. Y. and Boston, s. agts.; Ernest Lovering, buyer.
- MACKINTOSH, D. & SONS CO.;** \$100,000; (**D**) D. Mackintosh, pres.; J. G. Mackintosh, treas.; C. E. Mackintosh, agt. and buyer; Wm. H. Lee, supt.; Carded Cottons in



White and Colors; 550 cards; water and steam; dye; sell direct; capacity for coloring 30,600 lbs per day.

**MERRICK THREAD CO.** (Am. Thread Co) (C) L. R. Hopkins, pres; C. W. Rider, treas; Spool Cotton; 28,000 ring and 55,000 mule spindles; water and steam; dye; Am. Thread Co, N. Y., Boston and Phila, s. agts.

**SKINNER, WM. MFG. CO;** \$100,000; Sewing (S) Silks, Machine Twist, Sleeve Linings, Serges, Silk and Mohair Braids and Binding; 650 looms; 600 braiders; steam and water; dye; sell direct, N. Y., 107 Bleacher St.; 12 Summer St., Boston; Chicago and Phila.

**SPRINGFIELD BLANKET CO;** E. H. Wil. (W) Kinson, manager of W. H. Wilkinson estate, mgr; Walker Ainley, supt; Horse and Bed Blankets, Linings for Blankets and Duck Coats; 28 sets; 78 narrow and 105 broad looms; water; Wm. Ayres & Sons, Phila., T. A. Shaw & Co., Chicago, s. agts.; E. H. Wilkinson, buyer.

**Housatonic.** E-1. N. Y., N. H. & H. RR. Berk. Div.

**MONUMENT MILLS;** \$50,000; Geo. Church, (C) pres. and treas; J. H. C. Church, asst. treas. and clerk; T. G. Ramsdell, agt.; Thos. E. Brown, supt.; Warps, 48 to 60s, Marseilles and Crochet Quilts; 28,000 ring spindles; 142 looms; water; dye; sell direct; 214 Church St., N. Y.; T. G. Ramsdell, buyer.

**Hubbardston.** D-8. Fitch RR.

**HYGENIC BLANKET CO.** (successors to (W) Star Blanket Mfg. Co.); Jas. E. McWilliams, mgr; Horse Blankets and Carriage Robes; 3 sets; 16 looms; 10 sewing machines; water and steam; dye; sell direct.

**Hudson.** D-10. Fitch RR, B. & M. RR, Cent. Mass. Div.

**Hudson WORSTED CO;** J. L. Ballan. (W) tyne, mgr; H. T. Dyson, supt; Tops Combed on Commission (Bradford system); 9 combs; 10 cards; water and steam; J. L. Ballantyne, buyer.

**QUEENSBURY MILLS;** H. Hodgson. See Worcester.

**TAYLOR, THOS. & SONS;** Vale Mills; Elas. (C) tic Webs and Shoe Goring and Auto-Brace Suspenders; 14 looms; steam; sell direct. (Buy 12/2 to 60/2 cotton yarn.)

**Huntington.** E-3. B & A RR.

**MASSASOIT WOOLEN MILLS;** \$40,000; (W) F. C. Patterson, pres. and supt; D. N. C. Hyams, treas; Cheviots, etc; 6 sets; 34 broad looms; water and steam; dye; James Talcott, N. Y., s. agt. Firm, buyers.

**Hyde Park.** E-12. N. Y., N. H. & H. RRS.

**BLEAKIE, ROBT & CO;** \$200,000; Robt (W) Bleakie, pres; C. F. Allen, treas; F. H. Ambuek, supt.; Fancy Cassimeres, Worsteds and Uniform Cloths; 16 sets; 150 looms; steam; dye; Oelbermann, Dommereich & Co., Battelle, Hurd & Co., Krower, Turnbull & Co., s. agts. (Buy yarn.)

**GRAY, T. H. & CO;** John McKelligan, (W) supt.; Wool Shoddies, all Grades and Colors, Wool Extracts, and Carbonizing Rags, Wool, Noils, etc; 20 double cards; 6 shoddy pickers; 1 garnett; steam; dye; sell direct; T. H. Gray, buyer. Boston office, 170 Summer St. (Also custom work of all kinds.)

**SOMERSET KNITTING CO;** E. W. Knight, (K) pres. and treas; G. E. Bailey, supt; Bicycle and Golf Hose, Sweaters, Cardigan Jackets, Golf Vests, etc; silk and worsted; 6 knitting and 6 sewing machines; gas; sell direct and Ambrose & Fitzmaurice, s. agts; E. W. Knight, buyer.

**WILTON WOOL SCOURING MILLS;** Wm. (W) W. Scott, agt; John P. Scott, supt.; Wool Scoured and Sorted; steam.

**Indian Orchard.** F-5. B. & A. RR.

**AMERICAN FLAX CO;** \$150,000; H. G. (F) Chapin, pres; J. H. Clune, treas; Lnen Yarns and Towels; 2,500 spindles; 50 looms; steam and water; sell direct.

**HODGES FIBRE CARPET CO;** A. J. Bailey, (P) pres; F. R. Tibbitts, sec; Frank P. Hodges (Boston), treas.; Wm. M. Stevenson, supt.; Patent Paper Fibre Carpets, Art Squares and Rugs; 1,600 spindles; 150 looms; water; sell direct.

**INDIAN ORCHARD CO;** \$350,000; E. (C) Morgan, pres; H. K. Wight, treas; W. C. Godfrey, agt; Plain and Colored Warps, Hosiery and Weaving Yarns, Novelty Yarns, Carded and Colored Cotton; 20,000 spindles; water and steam; dye; sell direct. See advertisement.

**INDIAN ORCHARD CO;** Dyers of Cotton (D) Yarns, Warps and Raw Stocks. See advertisement.

**LILLIE, DEXTER P. & CO;** Wiping and (C) Packing Waste; 4 machines; water; sell direct.

**RHODE ISLAND WORSTED CO.;** \$40,000; (W) James D. Reilly, pres.; Daniel N. Brown, treas. and agt.; Walter Nieber, supt.; Men's Fancy Worsteds; 42 looms; steam; dye; H. W. T. Mali & Co., s. agts.

**Ipswich.** B-13. B. & M. RR.

**IPSWICH MILLS;** \$400,000; A. A. Law. (K) rence, pres; F. I. Eustis, treas; H. B. Brown, agt; E. Pickup, supt; Hosiery; 5 sets; 1000 knitting machines; water and steam; dye; Lawrence & Co. N. Y. and Boston, s. agts. Also mill at So. Boston, Mass.

**Jefferson.** D-8. B. & M. RR, Cent. Mass. Div, Fitch RR

**EAGLE LAKE WOOLEN CO;** Moritz Fin. (W) diegen, supt; Piece dye and Satinets; 5 sets; 86 narrow looms; steam and water; dye; Lawrie, Mann & Drowne, N. Y., s. agts.; M. V. B. Jefferson, buyer. (Buy No. 12 cotton and wool yarn.)

**JEFFERSON MFG. CO;** C. N. Bagley, supt; (W) Unions Cassimeres and Cheviots; 8 sets; 42 broad looms; steam and water; dye; Lawrie, Mann & Drowne, 61 Leonard St., and Battelle, Hurd & Co., N. Y., s. agts.; M. V. B. Jefferson, buyer.

**Lancaster.** D-9. B. & M. RR.

**LANCASTER MFG. CO;** L. M. Brown, pres; (C) W. F. Stiles, treas, agt, and buyer; J. C. Boland, supt; Yarns; 3000 ring spindles; steam and water; sell direct.

**Lawrence.** B-12. B. & M. RR, W. & So. Div.

**ARLINGTON MILLS;** \$2,500,000; Geo. (C & W) A. Nickerson, pres; Wm. Whitman (Boston), treas; Franklin W. Hobbs, asst. treas. (Boston); W. D. Hartshorne, agt; Cotton and Worsted Yarns, Worsted Tops and Worsted Dress Goods; worsted department; 82 combs; 1642 looms; 57,500 worsted spindles; 33,650 ring and 17,012 mule spindles, cotton department; steam; dye; Harding, Whitman & Co, N. Y., Phila. and Boston, s. agts.

**ATLANTIC COTTON MILLS;** \$1,000,000; (C) Jacob Rodgers, pres; Linzee Prescott, treas; Walter H. Summersby, agt; Sheetings and Shirtings; 60,000 ring and 38,000 mule spindles; 2385 looms; steam and water; Amory Browne & Co, Phila., N. Y. and Boston s. agts.

**BECK, WM. & CHAS;** 83 Holly St; Cotton (C) and Electric Covering and Lnen Fire Hose; 10 looms; steam; sell direct; Wm. Beck, buyer.

**BROWN & WHITTIER;** (formerly Brown (W) & Ackroyd); 556 Common St.; Worst Dress Goods and Worsted Yarns; 3200 worsted spindles; 70 looms; steam and water; sell direct, and C. A. Auffmordt & Co., s. agts.; Claude M. Whittier, buyer.

- BUTLER, WORSTED MILL;** So. Canal St. (**W**) Franklin Butler, agt; Worsted Tops, Commission Combing; 4 cards; 4 combs; steam and water; Franklin Butler, buyer.
- CRESCENT WORSTED CO;** Grotton St., So. (**W**) Lawrence; \$20,000; Percy A. Legge, pres; Edward Braithwaite, treas. and agt.; William Mitchell, supt; Worsted Yarns; 5000 spindles; steam; sell direct; Edward Braithwaite, buyer.
- ELSTON, HENRY.** See Methuen.
- ESSEX DYE WORKS;** W. Stuart & Co; 208 (**D**) Essex St.; Yarns, Braids, Piece Goods, etc; steam.
- EVERETT MILLS;** Essex St.; \$700,000; F. C. (**C**) McDuffie, treas; J. I. Milliken, agt; Wm. D. Twiss, supt; Cottonades, Chevots, Denims, Dress Goods, etc; 50,000 ring spindles; 1800 looms; steam and water; dye; Smith, Hogg & Gardner, Y. N. and Boston, s. agts. Agt, supt, or paymaster, buyers.
- FARWELL BLEACHERY;** So. Canal St.; (**BI**) \$200,000; J. W. Farwell, treas; K. W. Moses, agt; Cotton Piece Goods; capacity 20 tons per day; steam and water. Office 56 Summer St., Boston.
- GLOBE WORSTED MILLS;** (American (**W**) Woolen Co.); Allen St.; J. C. Ayer, pres.; Wm. M. Wood, treas.; J. W. Coggeshall, agt.; Worsted Yarns; 6 sets; 8500 spindles; 6 combs; steam; J. Clifford Woodhull, N. Y., s. agt.; H. J. Potter (Boston), buyer.
- HOLLINGS & SMITH;** (In part of Wamesit (**W**) Mill); Ladies Worsted Dress Goods, Chevots, Serges, etc., and Tape Banding for Spinning; 22 looms; steam and water; Converse, Stanton & Co., N. Y., s. agts. (Buy yarn.) (Removed plant from Windham, N. H.)
- KLOUS, HENRY.** See Methuen.
- KUNHARDT, GEO. E.;** Union St.; G. Otto (**W**) Kunhardt, agt; Men's Wear, Woolen and Worsted Fabrics; 12 sets; 200 looms; steam and water; dye; Kunhardt & Stockton, s. agts. Buy yarns.
- LAWRENCE DUCK CO;** \$300,000; James (**C**) Lougley, pres; Frank C. Roberts, treas; Wm. A. Barrell, agt; Duck and Paper Mill Felt; 10,000 ring spindles; 142 looms; water; W. L. Barrell & Co., 85 Water St., Boston, s. agts
- LAWRENCE DYE WORKS CO THE;** (**D&F**) \$100,000; I. L. Sjostrom, treas; Dyeing and Finishing of all Textiles; steam; (capacity 150 pieces per diem); I. L. Sjostrom, buyer.
- LAWRENCE KNITTING CO;** 165 Broadway; (**IK**) \$10,000; John D. Dodge, pres, and supt; Geo. A. Hunting, treas. and buyer; Men's Half Hose Ladies', Misses' and Boys' Cotton, Wool, Worsted and Merino Hosiery; 30 knitting machines; steam; sell direct.
- LEWIS, E. FRANK;** South Canal St.; H. (**W**) Bradford Lewis, supt; Wool Scouring and Carbonizing; office 143 Federal St., Boston.
- PACIFIC MILLS;** \$3,000,000; Arthur (**CW&Pr**) T. Lyman, pres; Geo. S. Silsbee, treas; Walter E. Parker, agt; Cotton and worsted Dress Goods; 144,000 ring and 41,000 mule spindles, cotton; 42 combs and 50,000 worsted spindles; 4000 cotton and 2600 worsted looms; print works, 27 machines for cotton and worsteds; steam and water; dye; Lawrence & Co., N. Y. Boston and Phila., s. agts.
- PATERSON, JAMES & CO.,** 317 Methuen (**W**) St.; Ladies' Dress Goods; 13 looms; steam.
- PEMBERTON CO;** \$450,000; H. S. Shaw, (**C**) pres. and treas; L. E. Barnes, agt; Various Cotton Goods; 26,000 spindles; 868 looms; water and steam; dye and bleach; The Nevins Co., N. Y. and Boston, s. agts; L. E. Barnes, buyer.
- PROSPECT WORSTED MILL;** (American (**W**) Woolen Co.); South Canal St.; J. C. Ayer, pres.; Wm. M. Wood, treas ; J. W. Coggeshall, agt.; Worsted Yarns; 7 cards; 4034 spindles; water; J. Clifford Woodhull, s. agt.; H. J. Potter (Boston), buyer.
- RUTTER BROS.;** (formerly at Lakeport, (**W**) N. H.) Woolen and Merino Yarns; 4 sets; 1744 mule spindles; steam and water; sell direct. (In Wamesit Mill.)
- SMITH, ROBERT M.;** 50 Island St.; Web- (**C**) bing; 7 looms.
- WALWORTH, BROS.;** Marston & Canal St.; (**W**) Ladies' Dress Goods; 60 looms; water; sell direct; J. P. Walworth, buyer.
- WASHINGTON MILLS** (American Wool- (**W**) en Co.); W. M. Wood, (Boston), treas; James Ingram, agt; Worsted Yarns and Men's Wear; 91 sets; 78,000 worsted spindles; 100 combs; 1500 looms; steam and water; dye; J. Clifford Woodhull, N. Y., s. agt.
- WRIGHT MFG. CO.;** 58 Island St.; \$60,000; (**W**) C. W. Stevens, pres; John P. Sweeney, treas; C. Swift, supt; Mohair and Worsted Braids and Bindings; 1010 braiding machines; water; sell direct; C. Swift, buyer. (Buy 2/18s to 2/40s worsted and mohair yarns.)
- Leicester.** E.S. Electric cars 6m at Worcester on B. & A. B. & M. N. Y. & N E, Fitch, N. Y. N. H. & H. and W. & S. RRs. See Cherry Valley & Rochdale.
- Leominster.** C.9. N. Y, N. H. & H. RR.
- LEOMINSTER WORSTED CO;** \$100,000; N. (**W**) Harwood, supt; Wm. H. Chase, treas; A. N. Litch, sec; J. H. Pickford, supt; Worsted Suitings Men's Wear; 3 sets; 102 broad and 5 narrow looms; steam; dye; sell direct; W. H. Chase and A. N. Litch, buyers. (Buy 30/2 40/2 50/2 worsted and 30/2 40/2 50/2 cotton yarns.)
- ROCKWELL, E. M.;** Wool and Merino (**W**) Yarn; 15 sets; steam and water; dye; sell direct; E. M. Rockwell, buyer.
- UNITED STATES THREAD CO., THE.;** Jos. (**C**) St. George, supt ; Thread for all Kinds of Manufacturing Trade; steam; sell direct; A. Victorson, buyer. (Buy all sizes cotton yarns.)
- Linden.** D-13. B. & M. RR.
- COLLINS, E. & Co.;** see Malden. ROSE, G. H.; see Malden.
- Littleton.** C-10. Fitch RR.
- CONANT, HOUGHTON & CO.;** W. E. Conant, (**C**) supt.; Suspender Webs; 38 looms; 40 braiders; steam; American Mills Co., N. Y., s. agts; W. E. Conant, buyer.
- Longmeadow.** G-5. N. Y, N. H. & H. RR.
- HITCHCOCK KNITTING MILL;** I. G. Hitch (**IK**) cock, supt; Sweaters, Golf Hose and Stockings; 13 knitting machines; 3 sewing machines.
- Lowell.** C-11. B. & M. RR, W and So. Div, and N. Y, N. H. & H. RR, No. Div.
- APPLETON CO.;** \$450,000; F. E. Dunbar, (**C**) pres; A. G. Cunnock, treas; F. A. Bowen, supt. and buyer; White Domets, Dress and Outing Flannels; 40,928 ring and 11,160 mule spindles; 1844 looms; steam and water; dye; Catlin & Co, Boston, N. Y. & Phila., s. agts.
- BARBER, WM.;** rear 256 Lawrence St.; (**C**) Tapes for Worsted spinners; 4 looms; sell direct.
- BAY STATE MILLS, (American Woolen (**W**) Co.;** W. M. Wood, (Boston), treas; John Faulkner, agt; Cloakings and Overcoat- ings; 30 sets; 103 looms; steam and water; dye; J. C. Woodhull, N. Y., s. agt.; H. J. Potter, (Boston), buyer.
- BELVIDERE WOOLEN MFG. CO.;** \$200,000; (**W**) Benj. Phipps, pres; Chas. A. Stott, treas. and agt; Chas. H. Walker, supt. No. 2 Mill; Dress Goods; 16 sets; 3700 mule spindles; 90 looms; water and steam; dye; Parker, Wilder & Co., N. Y. and Boston, s. agts

**BIGELOW CARPET Co.**; Lowell Division; (**W**) A. S. Lyon, supt.; Ingrains, Brussels, Axminsters and Wilton Carpets; steam and water. (See Clinton for officers and machinery.)

**BOOT COTTON MILLS**; \$1,200,000; Eliot C. (**C**) Clarke (Boston), treas.; N. B. Kerr, agt.; Cotton Goods, Plain and Fancy Linen Crashes, Towels, etc.; 50,000 ring and 68,000 mule spindles; 3380 looms; steam and water; Smith, Hogg & Gardner, N. Y. and Boston, s. agts.

**BRADSHAW MFG. Co.**; 599 Dutton St.; W. (**C**) F. Copson, treas.; Shoe Goring; 6 looms; 30 braiders. (Buy yarn.)

**BROWN HOSIERY Co.**; M. D. Brown, (**K**) prop.; 117 Plain St.; Men's and Children's Cassimere and Cotton Hosiery; 30 special automatic knitting machines; sell direct; (Buy worsted yarn 15s to 35s, single.)

**CAPUCINE CO. THE**; Tanner St.; \$500. (**D & F**) 000; B. Harrison, pres.; A. M. Harrison, treas.; Frank O. Small, supt. and buyer; Water Proofing and Moth Proofing Worsted and Cotton Fabrics, Custom work done for the trade; steam; C. Threshie & Co., Boston, s. agts.

**CRITERION KNITTING Co.**; 220 Tanner St.; (**K**) \$10,000; Warren C. Hamblett, pres.; Stephen B. Puffer, treas.; Men's, Women's and Children's Gauze and Jersey Underwear; 78 knitting machines; steam; Jas. Talcott, N. Y., s. agt.; S. B. Puffer, buyer.

**GREENWOOD & PAYTON Co.**; Walpole (**W & K**) St.; Wool, Cotton Hosiery and Yarns; 1 set; 20 knitting machines; steam.

**HAMILTON MFG. Co.**; \$1,500,000; Jas. (**C & Pr**) Longley, pres.; Chas. B. Amory (Boston), treas.; O. H. Moulton, supt.; Prints, Ticks, Cotton Flannels, Shirtings, etc.; 109,516 spindles; 3092 looms; steam and water; Print Works; 12 printing machines; Joy, Langdon & Co., N. Y. and Boston, s. agts.

**HAPGOOD, E., & SON**; 207 High St., Bel. (**W**) videre; Shoddy, Mattresses and Bedding Wool; 6 pickers; sell direct; Edgar Hapgood, buyer.

**HARRIMAN, JOSIAH**; Novelty Suspender (**C**) Works; 175 Hall St. and Thorndike St.; Factory A; Elastic Webs, Braids and Suspenders; 48 looms; Dept. B; Parker J. Johnson, supt.; 27 looms; steam; Townsend & Longmire, N. Y., s. agts.; Mr. Harriman, buyer. (Buy 12s to 40s.)

**HOOPER KNITTING Co.**; \$100,000; George (**K**) L. Hooper, pres. and gen'l mgr.; Horace P. Beals, treas.; Matthew C. Cottle, dyer and supt.; Full Fashioned and Seamless Hose and Half Hose in Cotton, Wool and Merino; 100 machines; steam; dye; sell direct; Geo. L. Hooper, buyer.

**LAWRENCE MFG. Co.**; foot Suffolk St.; (**C & K**) \$750,000; T. Jefferson Coolidge, pres.; C. P. Baker (Boston), treas.; Franklin Nourse, agt.; Cotton Underwear and Hosiery; 75,000 spindles; 1500 knitting machines; water and steam; dye; E. M. Townsend & Co., N. Y., Boston, Phila. and Chicago, s. agts.; C. P. Baker, buyer.

**LOWELL BLEACHERY**; \$400,000; (**H & D**) Geo. F. Richardson, pres.; Phillip Stockton, treas.; Charles E. Meader, agt.; R. I. Tobey, supt.; Cotton and Linen Fabrics, Bleached, Finished, Dyed, Indigo Blue; steam; 10,000,000 lbs. per annum.

**LOWELL HOSIERY Co.**; Mt. Ver. (**K & D** & **B**) non St.; \$200,000; Arthur G. Pollard, pres.; W. A. Eastman, treas.; Albert Deabill, supt.; Ladies' Seamless Cotton Hosiery; 19 cards; 3328 ring and 2640 mule spindles; 350 knitting machines; steam; dye and bleach; Bliss, Fabyan & Co., N. Y., Boston and Phila., s. agts.; W. A. Eastman, buyer. (Buy No. 8 to 50 yarns.)

**LOWELL MFG. Co.**; See Bigelow Carpet Co.

**LOWELL TEXTILE Co.**; West Adams (**C & F**) St.; \$35,000; Hughes Fawcett, pres.; E. S. Pead, treas.; C. E. Lamour, supt.; Towels, Crash, etc.; 60 looms; John Cathart & Co., 115 Franklin St., N. Y., s. agts.

**LOWELL TEXTILE SCHOOL**; A. G. (**C W & D**) Cummock, pres.; A. G. Pollard, treas.; Wm. W. Crosby, principal; Carding, Comb-ing, Spinning, Weaving and Designing; also Dyeing.

**LOWELL WASTE Co.**; 705 Gorham St.; \$40. (**C**) 000; Wm. H. Anderson, pres.; Otis D. Spoford, treas.; Waste; water.

**LOWELL WEAVING Co.**; 136 Walker St.; (**C**) (Inc. 1896); (P. O. Box 5150, Boston), \$30,000; Wm. Whitman, pres.; Chas. E. Kummer, (Boston), treas.; Geo. W. Dearborn, supt.; Bicycle Tire Cloth and Specialties; 100 looms; steam; Harding, Whitman & Co., N. Y. and Boston, s. agts.

**MASSACHUSETTS COTTON MILLS**; \$1,800. (**C**) 000; Arthur T. Lyman, pres.; Chas. L. Lovering (Boston), treas.; W. S. Southworth, agt.; J. C. Wadleigh, supt.; Canton Flannels, Denims, Duck, Awning stripes, Ticks, Drills and Export and Converting Goods, in Variety; 114,048 ring and 9040 mule spindles; 4,000 looms; water and steam; dye; Smith, Hogg & Gardner, N. Y. and Boston, s. agts. Also at Lindale, Ga.

**MASSACHUSETTS MOHAIR PLUSH Co.**; 122 (**W**) Western Ave.; E. P. Bliss, pres.; Henry W. Bliss, (Boston), treas.; Chas. Aveyard, supt.; Plush, Mohair and Lustre Yarns, Genapp and Novelty Yarns; 12 combs; 17,000 worsted spindles (about 3,000 are twisters; 358 looms; steam; dye; Cushing & Bliss, Boston, s. agts. E. P. Bliss, buyer. (Buy cotton yarns.)

**MERRIMACK MFG. Co.**; \$2,750,000; (**C & Pr**) Chas. L. Lovering, treas.; J. W. Pead, agt.; Cottons, Plain and Fancy; Bleached, Printed and Finished Linens, Towels, Corduroys; 126,672 ring and 42,432 mule spindles; 5028 looms; water and steam; dye; print works, 21 printing machines; Lawrence & Co., Boston, s. agts. (Above includes plant at Huntsville, Al.; 25,000 spindles and 850 looms.

**MERRIMACK WOOLEN Co.**; Chas. S. Cook (**W**) (Portland), pres.; Chas. A. Robinson (So. Windham), treas.; Beavers, Kerscys, etc.; 20 sets; 83 broad looms; water and steam; dye. Mills at Dracut.

**MIDDLESEX Co.**; \$750,000; C. P. Curtis, (**W**) pres.; O. H. Perry, treas.; O. Saunders, agt.; Cassimeres, Beavers; 53 sets; 17,080 mule spindles; 230 looms; water and steam; dye; Wendell, Fay & Co., N. Y., Boston and Phila., s. agts.

**NEW ENGLAND BUNTING Co.**; Davidson (**W**) St.; E. S. Hyland, treas.; E. J. Hyland, supt.; Bunting and Dress Goods; 2880 worsted spindles; 248 looms; water and steam; dye; Wellington, Sears & Co., s. agts.; E. S. Hyland, buyer.

**PICKERING MFG. Co.**; (Incorp.) \$300,000; J. (**K**) W. C. Pickering, pres.; H. D. Pickering, treas.; W. W. Norcott, supt.; H. E. Pickering, sec. and asst. supt.; Ladies', Men's and Children's Knit Underwear; steam; Shreve & Adams, 86 Leonard St., N. Y., s. agts.; H. D. Pickering, buyer.

**RODGER, ANDREW Y.**; 287 Thorndike St.; (**C**) Narrow Fabrics and Elastic Webs; 5 looms. (Buy 10 2 to 80 2 and 30 1 to 80 1 yarn.)

**RODGER, WM. M. & Co.**; 599 Dutton St.; (**C & S**) Narrow Fabrics and Elastic Webs; 5 looms; steam. (Buy yarns 10/2 to 80/2 and 30/1 to 50/1.)

**SHAW STOCKING Co.**; \$360,000; F. J. (**K**) Dutcher, pres.; Wm. E. Hall, treas. and mgr.; Chas. F. Libby, supt.; Cotton, Wool, Merino, Worsted, Lisle and Linen Half Hose, Children's Fine Ribbed Full Fashioned Hose; 7,500 cotton spindles; 400

- knitting machines; steam; dye; sell direct; N. Y. office, 396 and 398 Broadway; Boston, 77 Bedford St.; Wm. E. Hall, buyer.
- STIRLING MILLS**; \$100,000; Wm. H. Sher. (**W** man, pres; Benj. Phipps (Boston), treas; E. D. Holden, agt; Flannels, Cheviots and Dress Goods; 6,120 mule spindles; 13 sets; 100 looms; steam and water; dye; Parker, Wilder & Co, N. Y. and Boston, s. agts.
- THORNDIKE MFG. CO.** (Plant purchased by Josiah Harriman, which see.)
- TREMONT & SUFFOLK MILLS**; \$2,600,000; (**C** A. T. Lyman, pres; Alfonso S. Covel, treas; M. A. Rawlinson, supt; Flannels, Sheetings, Colored French Shirtings, Drills, Blankets and Hosiery Yarns; 187,000 spindles; 5950 looms; water and steam; dye; Smith, Hogg & Gardner N. Y. and Boston; s. agts.
- U. S. BUNTING CO**; W. H. McDaniels, (**W** gen'l mgr; Worsted Dress Goods 13 sets; 270 looms; H. & W. H. Lewis, N. Y., Phila. and Boston, s. agts. See also Walsh Worsted Mill.
- WAITE'S PERFECTION BANDAGE CO.**; Saml. (**C** and Waite, prop.; Cushing and Willie Sts.; Selvage Edge Light Gauze Surgical Bandages; 1 loom. (Buy yarn, single, on beams and spools.)
- WALSH, WM. E.**; Park Worsted Mill; (**W** Walter Killerby, supt.; Worsted Yarns; (Bradford system); 1 set; 1100 spindles; 1 comb; steam; sell direct; Wm. E. Walsh, buyer.
- WALSH MILL**; United States Bunting (**W** Co.; Craven Midgley, supt; Worsted Yarns; 5 cards; 4 combs; steam.
- WATERHEAD MILLS**; (formerly old (**C** & **D** Kendall mill); Hockmeyer Bros., N. Y. interested; Dye and Finish Corduroy and Velvets.
- WAUKENHOSE MFG. CO**; 146 Fletcher St.; (**K** \$125,000; H. A. Lambert, pres; W. H. Howard, treas; William Liddle, supt; Hosiery, "Waukenhose;" 100 knitting machines; steam; sell direct.
- Ludlow.** F. 5. B. & A. RR.
- LUDLOW CORDAGE CO**; \$100,000; Edward (**J** Brooks, pres; C. N. Wallace, treas; J. E. Stevens, agt; Manila and Sisal Cordage; water; sell direct. C. N. Wallace, buyer. Office, 133 Essex St
- LUDLOW MFG. CO**; \$750,000; R. H. Weld, (**J** pres; Charles W. Hubbard (Boston), treas; J. E. Stevens, mfg. agt.; Jute and Hemp; water and steam; sell direct; C. N. Wallace, 133 Essex St., Boston.
- Lynn.** D-13. B. & M. RR, E. Div, and B. R. B. & L. RR.
- CURTIS & SPINDELL CO**; Elastic Stock. (**K** ings, Supporters, etc; 12 knitting machines; 4 sewing machines; electric power; I. F. Spindell, buyer.
- PARKER BROS MFG. CO**; \$30,000; T. B. (**C** Parker, pres.; G. C. Parker, sec.; Seam Stay, Piping and Binding, Furniture Gimp, and all kinds of Ribbon, Leather, Side Linings, Stamp Stays, etc.; steam; sell direct; Geo. T. Parker and T. B. Parker, buyers.
- Malden.** D-12. B. & M. RR, E. & W. Divs.
- ADAMS PRINT WORKS CO**; \$10,000; (**P**r James A. Lind, pres, and supt; Harry B. Adams, treas; Prints; steam; dye.
- CLARK HOSE CO**; 80 Jackson St. C. H. (**C** Eberle, supt.; Cotton and Linen Fire Hose; 8 looms; steam; sell direct; C. H. Eberle, buyer.
- COCHRANE MFG. CO**; \$20,000; (**P**r **D** & **H**i John Cochrane, pres; J. E. Cochrane, treas; Calico Printing, Dyeing and Bleaching; 7 printing machines; steam. (N. Y. office, Worth St.) (See also Dedham, Mass., and Danielson, Ct.)
- COLLINS, E. & CO**; 383 Lynn St.; Mittens, (**K** Bicycle and Golf Hose and Gloves; 35 knitting machines; steam; sell direct.
- GOULD WIRE CORD CO**; \$5,000; S. A. (**C** Gould, pres. and treas; M. McSweeney, supt; S. A. Gould, buyer; Wire and Cotton Cordage; steam; sell direct (Buy 8/2, 8/3 20/1 yarns.)
- NIEDNER, CHAS. II.**; 20 James St; Wm. (**C** Niedner, gen'l mgr. and supt; Linen and Cotton Fire Hose also Cotton Electric Tubing; 50 looms; steam; sell direct; buy linen and cotton.
- ROSE, GEO. II.**; 46 Fenwick St.; Mittens; (**K** 2 knitting machines; sell direct.
- TATE & CO**; Cotton Cordage; 150 braid. (**C** ers; sell direct.
- Manchaug.** F. 9. Station at E. Douglas, on N. Y. & N. E. RR.
- MANCHAUG CO**; Robt. Knight (Prov.), (**C** treas; D. M. Thompson, gen'l mgr; Chas. M. Holmes, supt; Sheetings, Shirtings and Cambrie; 24,736 ring and 29,824 mule spindles; 1200 looms; water and steam; sell direct; Wm. O'Neil, Prov., buyer.
- Mansfield.** G-12. N. Y. N. H. & H. RR, No. and Prov. Divs.
- MANSFIELD PRINT WORKS**; Turkey (**P**r Reds, Flannellettes, Domets; 2 machines; steam.
- ORR, CHARLES F**; Tubular Shoe Laces (**C** and Glazed Yarns; 200 braiders; dye; sell direct.
- SMILEY, DAVID & CO.**; Wool Waste, (**W** Shoddlies and Flocks; dust and mix; steam. (Also Dealers.)
- Maynard.** D-10. Fitch. RR.
- ASSABET MILLS.** (American Woolen (**W** Co.); W. M. Wood (Boston), treas; George Hinchcliffe, agt; Cassimeres, Flannels, Indigo Goods, Tricots, Suitings, etc; 143 sets; 1000 looms; water and steam; dye; J. C. Woodhull, N. Y., s. agts; H. J. Potter, (Boston), buyer.
- Medford.** D-12. B. & M. RR, W. Div.
- GLENWOOD WORKS**; \$40,000; (**D**, **B**i & **F** Joseph W. Woods, pres. and treas; Frank Fallon, agt. and supt; Dyers, Bleachers and Finishers of Cotton Fabrics; steam. Joseph W. Woods, buyer. Boston office, 31 Bedford St.
- MEDFORD WOOLEN MFG. CO.**; \$50,000; (**W** Geo. C. Wetmore, treas.; Wool Felt Boots; 4 sets; dye; steam; sell direct.
- MYSTIC PRINT & DYE WORKS**; (**P**r **D** & **H**i Inc.) \$125,000; Geo. A. Chipman, pres; John D. Street, treas, agt. and buyer; R. H. Bryden, supt; Printing, Dyeing, Bleaching and Finishing Cotton Fabrics; 4 printing machines; steam.
- Medway.** F-11. N. Y. & N. E. RR.
- COLE, SENIOR & CO**; D. W. Senior, agt, (**W** supt. and buyer; Fine Kerseys, Meltons, Overcoatings and Fancy Cassimeres; 5 sets; 1 narrow and 25 broad looms; water and steam; dye; Lawrie, Mann & Drowne, N. Y. s. agts. (Buy silk and mercerized cotton yarns for stripping.)
- HIRSH & PARK**; Ladies' Fur also Wool (**W** Hats; steam; dye; sell direct, 596 Broadway, N. Y.
- RAY & WILSON**; Batting and Wadding; (**C** 18 cards; 12 pickers; steam and water; G. E. Daniels & Son, N. Y. s. agts
- Mendon.** F-10. Stage at Milford, on B. & A. N. Y. & N. E. and G. & M. RRs.
- SWAN, W. H.**, estate of; Flocks and (**W** Shoddy; steam. Burned. May rebuild.
- MENDON WOOLEN MILLS**; Geo. R. Whit. (**W** ing; Abbott D. Whiting, supt; Shoddy and Extracts, also Carbonizing; 9 sets; 3 pickers; 3 carbonizers; steam and water; dye; sell direct. (P. O. address, Unionville.)

**Methuen.** B 12. B. & M. RR, Man. I. & Br. ELSTON, HENRY; 65 Centre St; Worsted (W) Dress Goods; 8 looms; steam.

JOWETT, JOHN W; Methuen Yarn Mill; (W) (P. O. Box 392) Woolen and Merino Yarns; 5 sets; 2000 ring spindles; steam; sell direct.

KLOUS, HENRY; Shoddy and Wool Substitutes; 3 pickers; 15 cards; 1 garnet machine; steam; dye; P. O. Lawrence.

KNITTED FABRICS Co; Broadway; (Inc. (K) 1883); \$100,000; C. H. Wood, pres; Edw. L. Wood, treas; F. Remick, agt. and supt; Stockinets, Jersey Cloth and Astrachans; 48 knitting machines; steam; dye; sell direct; F. Remick, buyer.

METHUEN CO; \$400,000; Henry S. Shaw, (C) pres; Lawrence Mayo, treas; Lewis E. Barnes, agt; Chas. E. Collins, supt; Cotton Goods; 16,000 spindles; 616 looms; steam and water; dye; The Nevins Co, N. Y. and Boston, s. agts.

METHUEN HAT CO; Broadway; (suc. (W) cessor to J. M. Tenney); \$15,000; Wool Hats; 8 sets; steam; dye; C. H. Tenney & Co., N. Y., s. agts.

SPICKET FALLS BLEACH & DYE (BI & D) WORKS; C. A. Johnson, prop.; 48 Osgood St.; Short Skin and Raw Stock.

SWAIN MFG. CO; C. F. Swain, prop.; (K) Jersey Cloths; 4 knitting machines.

TREMONT WORSTED CO; Worsted Suit. (W) ings and Cotton Worsteds; 29 looms; buy worsted, woolen and cotton yarn; steam; sell direct.

**Middleboro.** H. B. N. Y, N. H. & H. RR. Plym. and Taunt. Divs.

FARWELL WORSTED MILLS; F. S. Farwell, treas; C. W. Barnes, buyer; Worsted Piece Dyed Goods, for Men's Wear; 8 sets; 70 looms; steam and water; sell direct. (Also Central Falls, R. I., which see.)

**Milford.** F. 10. N. Y, N. H. & H. RR; B. & O. RRs

LAPWORTH WM. & SONS; Elastic and Non-Elastic Fabrics; 35 narrow looms; steam; finish; buy cotton 2 1/2 to 8 1/2 and silk; Wm. or Frank A. Lapworth, buyers.

**Millbury.** F. 9. B. & A. RR, and N. Y., N. H. & H. RR, Wor. Div. See also W. Millbury.

BOWDEN FELTING MILLS CO.; \$50,000; (W) John R. Farnum, pres.; H. L. Bowden (Boston), treas.; H. O. Sutcliffe, supt.; Felts; steam and water; dye; sell direct from Boston, N. Y., and Phila. offices; H. L. Bowden, buyer.

CORDIS MILL; \$120,000; Geo. F. Fabyan, (C) Boston, pres; P. Olsen, Boston, treas; Fred W. Moore, agt.; Ticking; 6800 ring spindles; 212 looms; water and steam; dye; Bliss, Fabyan & Co, N. Y., Boston and Phila, s. agts.

KOTED SILK UNDERWEAR CO; \$200,000; W. (K) M. Keepers, pres; David F. Halsted, treas.; S. A. Dodge, supt; Koted Silk Underwear; 2504 spindles; 10 sets; 39 knitting machines; steam and water; dye; Fleitmann & Co., 484 Broome St., N. Y., s. agts.

MAYO WOOLEN CO; \$100,000; Thomas P. (W) Curtis, pres; Edward J. Mayo, treas; J. R. Greenwood, supt; Dress Goods and Cloakings; 11 sets; 96 looms; steam and water; dye; Deering, Milliken & Co; N. Y., agts. 2 mills.

MILLBURY COTTON MILLS; H. N. Camp (C) bell, Jr., trustee; Print Cloths; 12,842 spindles; 300 looms; water and steam. *Idle; for sale.*

MOLT BROS.



MOLT BROS; Indigo Blue Dyers; steam (D) and water; dye. [Manufacturers of Reduced Indigo Blue dye. Also dyers of Wool and Stock, yarn and pieces; unions, etc. All shades. All work done by experienced workmen and guaranteed to give satisfaction. Also do Commission Wool Scouring.]

RHODES WARP CO, JOHN; \$75,000; H. M. (C) Wilcox, pres. and treas; O. C. Owen, supt.; Satinets, Warps and Yarns; 8192 spindles, water and steam; sell direct.

RICH, JOHN S; Shoddy and Flocks; 2 (W) pickers; 2 cutters; water. (Also Oxford.)

UNION HAMMOCK CO; C. F. Marston, (C) pres; E. E. How rd, treas; Charles C. Shepard, supt; All Kinds of Hammocks; 10 looms; steam.

WEST END FLAX MILLS; Walter L. Whit (F) ney; Linen Shoe Threads; steam and water; dye; Dean, Chase & Co, Boston, s. agts.

See also West Millbury.

**Mills.** F. 11. N. Y., N. H. & H. RR.

NATIONAL FLAX FIBRE CO.; *Failed.* Re. (F) ported re-organizing.

**Millville.** G. 10. N. Y, N. H. & H. RR, Wor. Div.

IRON STONE WOOLEN CO. See *Uxbridge.*

LAWRENCE FELTING CO.; Felting of all (W) kinds, Shoddy and Coloring of Cotton Goods; 75 cards; steam and water; dye; sell direct.

PITTS, JAMES, & SON; (P. O. address (W) Forestdale, R. 1.) Wool Flocks of all Colors and Grades, also Dealers in Gig and Shear Flocks; 4 Flock Cutters; water; dye; sell direct; F. J. Pitts, buyer. See Slatersville and No. Smithfield, R. I.

**Monson.** F. 6. Cent. Vt. RR.

CUSHMAN, S. F. & SONS; Kerseys and (W) Cloakings; 5 sets; 24 looms; steam and water; dye; H. J. Libbey & Co., N. Y., s. agts.

ELLIS, D. W. & SON; Arthur D. Ellis, (W) agt.; Frank Entwistle, supt.; Venetian Broad Cloth-, Kerseys and Carriage Cloth-; 4 sets; 23 looms; water and steam; dye; Sullivan, Vail & Co., s. agts.; A. D. Ellis, buyer. (Purchased one of the Reynolds's mills.)

HERITAGE & HIRST; Chas. Heritage, agt., (W) supt. and buyer; Overcoatings and Suitings; 6 sets; 4 narrow and 42 broad looms; 160 ring and 1851 mule spindles; steam and water; dye; Converse, Stanton & Co., s. agts. (Buy 40 2 and 30 2 worsted yarns and 30 2 cotton yarns.) (Operating one of the mills of the R. M. & Theo. Reynolds Estate.)

LANGEWALD, F. A. W.; Crescent Worst. (W) ed Mill; Weaving and Finishing Worsteds; 12 looms.

ROSENBERG, L. R. (owner); 3 sets; 24 (W) looms; Purchased branch mill S. F. Cushman & Sons. (Leased by J. H. Loudon, of Wales, now operating.)

**Needham.** E. 12. N. Y. & N. E. RR.

MOSELEY, WM; Surgical Elastic Hos. (K) istry and Bandages; 3 knitting machines; sell direct.

WYE, GEO. E.; Silk, Worsted and Wool (K Sweaters, Athletic Goods, etc.; 25 power, 7 hand knitting machines; 12 sewing machines; sell direct. (Buy W. & Wd. yarn.)

WYE, WM. H. & Co., (successors to (K Wye Bros. & Co.); Athletic Goods, Sweaters, Golf and Bicycle Hose; 60 power machines; 7 hand knitting machines; 18 sewing machines; electricity; sell direct.

**New Bedford.** K-13. N. Y., N. H. & H. RR. Taunt. Div.

ACUSHNET MILL CORP.; \$800,000; J. F. (C Knowles, treas.; J. W. Knowles, supt; Sheetings, Twills, and Silk and Cotton Goods, etc.; 68,000 ring and 40,000 mule spindles; 4600 looms; steam; sell direct.

BEACON MFG. CO.; \$60,000; Chas. E. (C Riley (281 Congress St., Boston), pres.; A. DeCort (281 Congress St., Boston), treas.; Herbert Bragg, supt; Carpet and Hosiery Yarns on woolen system; 6 sets wool cards; 1500 cotton spindles; steam; sell direct from Boston office.

BENNETT SPINNING CO.; (New England (C Cotton Yarn Co.) L. E. Bentley, supt; Yarns; steam; sell from New Bedford office.

BRISTOL MFG. CO.; \$500,000; Thomas H. (C Knowles, pres.; Edw. O. Knowles, treas. and agt.; L. W. Powers, supt; Print Cloths, Sateens and Fancy Goods; 50,000 ring spindles; 1434 looms; steam; sell direct; Edw. O. Knowles, buyer.

CITY MFG. CORP.; \$750,000; Thos. H. (C Knowles, pres.; Benj. Wilcox, treas.; Geo. A. Ayer, supt; Yarns in Skeins, Chains, etc.; 65,000 spindles; steam; sell direct. Geo. A. Ayer, buyer.

CORNELL STOCKING CO.; Pope St.; \$29,000 (K J. C. Nowell, treas.; Walter J. Roberts, supt; Cotton Hosiery; 100 knitting machines; steam; dye; sell through brokers.

DAKTHMOUTH MFG. CORP.; \$600,000; Chas. (C E. Riley, pres.; Jas. W. Allen, treas.; Walter H. Langshaw, mfg. agt. and supt.; Fine Cotton Goods, Plain, Fancy Lenos, and Specialties, 120,000 ring and mule spindles; 3,000 looms; steam; sell direct.

GRINNELL MFG. CORP.; \$1,000,000; Edward (C Kilburn, pres.; Otis N. Pierce, treas.; Robt. Burgess, agt. and buyer; Plain and Fancy Cotton Goods; 66,024 ring and 40,314 mule spindles; 3000 looms; steam; sell direct.

HATHAWAY MFG. CO.; \$400,000; Jos. F. (C Knowles, treas.; Wm. Swiss, supt; Fine Cotton Goods; 100,000 spindles; 3000 looms; steam; sell direct.

HOWLAND MILLS; (New England Cotton (C Yarn Co.) Yarns; steam; sell from New Bedford office.

LAMBETH ROPE CORP.; \$50,000; H. C. (C Sibley, pres.; F. A. Wilson, treas. and agt. and supt; Cotton Transmission, Rope, Banding, Braids, Cotton Cordage, Twines, etc.; steam; sell direct. F. A. Wilson, buyer. (Buy ss to 40s single, plied tubes, warps, cones, cops and skeins.)

NEW BEDFORD CORDAGE CO.; C. W. Plum. (J mer, pres. and gen'l. mgr; W. T. Jenney, treas.; John Eldridge, Jr., supt; Patent Cordage, Ship Rigging, etc. Binder Twine; steam, sell direct; office, Court and Ash Sts. at factory.

NEW BEDFORD SPINNING CO. (New Eng. (C Land Cotton Yarn Co.); 37 N. Water St., New Bedford; Thomas F. Gleason, supt; Yarns; steam; sell from New Bedford office.

NEW BEDFORD TEXTILE SCHOOL; Machinery for instruction purposes; C. P. Brooks, managing director.

NEW ENGLAND COTTON YARN CO.; 37 (C No. Water St., New Bedford; \$10,000,000; Andrew G. Pierce, pres.; H. C. Sibley, treas.; William L. Benedict, sec.; James E. Stanton, Jr., agt; Jos. F. Knowles, chairman executive committee; Yarns

and Hosiery Yarns; 650,000 spindles; goods sold from New Bedford, with branch offices in Albany, Boston, New York and Philadelphia; operating following mills: Bennett Mill, New Bedford.

Howland Mills Corp., New Bedford. New Bedford Spinning Co., New Bedford. Rotch Spinning Corp., New Bedford. Cohannet Mills, Taunton. Nemasket Mills, Taunton. Globe Yarn Mills, Fall River. Sanford Spinning Mill, Fall River.

ONEKO WOOLEN MILLS; Holden Leon. (W ard & Co.; W. C. Hitchcock, agt; Chas. W. Abel, supt; Fine Woolen Fabrics; 15 sets; 68 looms; steam; dye; sell direct. W. C. Hitchcock and J. S. Holden (Bennington, Vt.), buyers. (Also Bennington, Vt.)

PIERCE MFG. CORP.; \$600,000; A. G. (C Pierce, pres.; A. G. Pierce, Jr., treas.; A. R. Pierce, supt; Fine Cotton Goods; 43,200 ring and 46,636 mule spindles; 3000 looms; steam; sell direct.

POTOMSKA MILLS; \$1,200,000; Andrew G. (C Pierce, pres.; Wm. O. Devoll, treas.; Frederic W. Reynolds, supt; Fancy Goods, Sateens and Lawns; 50,000 ring and 54,000 mule spindles; 2600 looms; steam; sell direct and Creighton & Burch, N. Y., s. agts.; Wm. O. Devoll, buyer.

ROTCH SPINNING CORP. (New England (C Cotton Yarn Co.); Yarns; steam; sell direct from New Bedford.

SOULE MILLS CORPORATION; \$750,000; (C Rufus A. Soule, pres.; Frederick B. Macy, treas. and agt.; John Neild, supt.; Fine Goods, Lawns, Fancies, Dimities, Organ-dies, Lenos, etc.; 24,640 ring and 24,480 mule spindles; 1000 looms, at present; (capacity 48,384 ring and 40,800 mule spindles; 2000 looms; steam; sell direct; Fred'k B. Macy, buyer.

WAMSUTA MILLS; \$3,000,000; Wm. W. (C Crapo, pres.; E. T. Pierce, treas.; H. E. Wamsley, agt; J. Neild, J. O. Thompson, Jr. and H. Hingham, supts; Sheetings, Shirtings, Lawns, Cambrics, Muslins and Yarns; 97,000 ring and 136,000 mule spindles; 4400 looms; steam; Grinnell, Willis & Co., N. Y., and F. A. Foster & Co., Boston, s. agts.; H. E. Wamsley, buyer.

WHITMAN MILLS; \$1,500,000; Edgar (C Harding, pres.; W. C. Taber, treas.; Wm. A. Congdon, agt.; Plain and Fancy Cotton Goods; 33,000 ring and 33,640 mule spindles; 1700 looms; steam; Harding, Whitman & Co., N. Y. and Boston, agts. (Jan. 3/02 plans prepared for new mill of 68,000 spindles; 1700 looms, giving total of 132,000 spindles and 3400 looms when done in both mills.)

**Newburyport.** A-13. B. & M. RR, W. and E. Divs

BAYLEY HAT FACTORY; (Merrimac Hat (W Co.); (Removed to Amesbury.)

BAY STATE CORDAGE CO.; \$125,000; H. F. (J Hineckley, pres.; S. B. Hineckley, Jr. treas.; Manila and Sisal Rope and Binder Twine; Hineckley Bros. & Co., 38-60 Commercial St., Boston, s. agts. and buyers.

PEABODY MFG. CO.; \$90,000; Leontine Lin. (C coln, pres.; S. A. Borden. (Fall River) treas.; O. D. Drew, supt. Mill No. 1; J. H. Grant, supt. Mill No. 2; Sateens, Sheetings and Shirtings; 42,200 ring and 14,200 mule spindles; 1320 looms; steam; sell direct; S. A. Borden, buyer.

**Newton.** E-12. B. & A. RR.

DALBY, THOS. CO.; \$50,000; Thomas A. (K Dalby, pres.; T. A. Dalby, treas. and buyer; Knit Goods, Ladies' and Infants' Underwear; 80 knitting machines; steam; H. W. Bryant, N. Y.; John Taylor, Chicago and D. S. Jacobs, San Francisco, s. agts. (Buy 20, 30, 40 and 50 worsted and cotton yarn.) Mill at Watertown.

NONANTUM MILLS; Part of mill oper. (W ated by Geo. F. Hall on Worsted Yarns,

Bradford System. Drawing and spinning only; 22 combs; 150 looms; (idle); steam; dye.

**SAXONY WORSTED MILLS;** Samuel Hys. (**W**) loom, treas. and agt.; Fine Worsted Yarns, 208 to 708 (French System); 3600 spindles; steam; sell direct. (To add 7360 more spindles). (Operating part of the Nonantum Mills).

**SILVER LAKE CO;** \$75,000; Henry S. Shaw, (**C**) pres.; Geo. H. Shapley, treas.; Braided Sash Cord, Lines and Steam Gauges; 420 braiding machines; sell direct; 78 Chauncy St., Boston; Geo. H. Shapley, buyer.

**Newton Lower Falls.** E. H. B. & A. RR. **DUDLEY MILLS** (Inc. 1880); \$100,000; (**K**) Henry F. Coe (Boston), treas.; James Buchan, agt.; Mens' Underwear; 6 sets wool; 8 sets cotton; 38 knitting machines; 85 sewing machines; steam and water; dye; sell direct and James Talcott, N. Y., s. agt.

**SILURIAN MILLS;** W. S. & F. Cordingley (**W**) (Boston), props; Shoddy and Extracts; 16 cards; 9 pickers; 4 garnett machines; water and steam; dye; 559 Atlantic Ave., Boston.

**SULLIVAN, R. T. CO;** \$50,000 A. G. Hos. (**W**) mer, pres. and supt.; Thos. J. Sullivan, treas.; Shoddy and Extracts; 15 cards; 6 pickers; 7 garnetts; steam and water; dye; sell direct. Boston office 200 Summer St.

**Newton Upper Falls.** E. 12. N. Y, N. H. & H. RR, Cent. Div. and B. & A. RR.

**CHEROKEE TURKEY RED DYE WORKS;** (**D**) Dyers and Bleachers Worsted Yarns, Knitting Yarn, Hosiery, Underwear, Wool, Cotton Yarn, Cotton, Novelty Yarn, Slubbing; Specialty Turkey Red Dyeing, Boston office, 54 India St.

**NEWTON MILLS;** Ryle, Wm. & Co (New (**S**) York), props; Charles P. Kelly, agt.; Thos. O'Hara, supt.; spun Silk Yarns in Warps, Cones, Tubes, or Spools; steam and water; dye; sell direct; 54 Howard St., N. Y.; Chas. P. Kelly, buyer.

**Norfolk.** E. 11. (City Mills) N. Y, N. H. & H. RR. See also Franklin.

**AMERICAN FELT COMPANY;** City Mills; (**W**) Felt Goods; 31 felting cards; steam and water; dye; sell direct. Mills at City Mills. (See New York City for officers.)

**North Abington.** F. 13. N. Y, N. H. & H. RR, Plymouth Div.

**VICTORY WEBBING CO.;** A. C. Woodward, (**C**) agt., supt and buyer; Webbing of all kinds; 52 looms; steam; sell through jobbers. (Buy 8/2 to 50/2 skein yarns.)

**North Adams.** B. 2. Fitch. RR, and B. & A. RR.

**ARNOLD PRINT WORKS;** (**C, Bl, D & Pr**) \$3,600,000; A. C. Houghton, pres.; Wm. Arthur Gallup, treas.; F. P. Pearson, mgr. Print Works; Bleaching, Dyeing and Printing of Textiles and Cotton Manufacture; 16 printing machines; water and steam; sell direct; offices at N. Y, Boston, Chicago and St. Louis; Wm. Arthur Gallup, buyer.

**BEAVER MILL;** Arnold Print Works; H. (**C**) Burnham, supt; Fine Goods; 29,152 spindles; 900 looms; steam and water; sell direct.

**BERKSHIRE MILL, No. 3.** See Adams. (**C**) **DUNBAR MILLS CO.;** \$100,000; D. D. Parm. (**C**) ley, (New York), pres.; and treas.; C. W. Dennett, agt.; Gingham and Fancy Dress Fabrics, 320 looms; Duval & Cone, N. Y., s. agts.

**ECLIPSE MILL.** Arnold Print Works; (**C**) H. Burnham, supt; Fine Goods; 29,120 spindles; 950 looms; steam and water; sell direct.

**GREYLOCK MILLS;** \$247,400; Wellington (**C**) Smith, pres.; W. B. Plunkett, treas.; H. C. Phillips, supt.; Fine Cotton Goods; 12, 448 ring and 13,536 mule spindles; 602 looms; water and steam; sell direct; Gay D. Thayer, buyer.

**JOHNSON MFG. CO;** \$500,000; D. D. Parm. (**C**) ley, (New York), pres. and treas.; C. W. Dennett, agt. and buyer; Fine and Fancy Dress Goods, Union Textures; 10,000 ring spindles; 486 looms; water and steam; dye; W. H. Burgess & Co., N. Y. and Boston, s. agts.

**NO. ADAMS MFG. CO.;** \$150,000; H. G. B. (**W**) Fisher, pres.; E. B. Penniman, treas. and agt.; Thos. W. Sykes, supt.; Fancy Casimeres Ch. viots, etc.; 14 sets; 60 looms; water and steam; dye; sell direct; 64 Worth St., N. Y.; E. B. Penniman, buyer.

**STRONG, HEWAT & CO;** Jos. S. Manock, (**W**) supt.; E. H. Farnsworth, buyer; Scotch Cheviots; 8 sets; 47 looms; water and steam; dye; sell direct; 56 Worth St., N. Y., 78 Chauncy St., Boston and Medinah Bldg, Chicago. Linwood Mill at Briggsville.

**WINDSOR CO.;** \$1,600,000; Wm. (**D Bl & Pr**) H. Hill, pres.; Emil Kipper (N. Y.), treas.; Chas. M. Howard, agt.; D. A. Russell, mgr.; Printed, Dyed and Bleached Fine Cotton Fabrics; water and steam; P. Van Volkenburgh & Co., N. Y., s. agts.

**Northampton.** E. 5. B. & M. RR, Cent. Mass. and Conn. R. Divs. and N. Y, N. H. & H. RR, Northampton Div.

**BELDING BROS. & CO;** \$1,000,000; M. M. (**S**) Belding, pres.; M. M. Belding, Jr, treas.; E. F. Crooks, mgr; Sewing Silk, High Class Silk Linings, Wash Embroidery Silks; Organzines, Trams, Insulating Silks; 40,000 spindles; 175 looms; steam; dye; sell direct; E. F. Crooks, buyer. (Buy 40 to 70 cotton and 6 to 75 spun-silk yarns.) Mills at Rockville, Conn., Belding, Mich., Petaluma, Cal., and Montreal, Can.

**MCCALLUM HOISIERY CO;** \$50,000; A. Mc. (**K**) Callum, pres.; Geo. B. McCallum, treas.; Wool Tights, Silk Hoisery and Toques; 36 knitting machines; electric power; sell direct.

**No. Andover.** B. 12. B. & M. RR, W. Div.

**BRIGHTWOOD MFG. CO, THE;** (**W, D & F**) \$20,000; Granville E. Foss, Jr, pres.; Geo. H. Simonds, treas.; Granville E. Foss, Jr, agt.; Charles Wilde, supt.; Fine Worsted and Novelty Dress Goods; also dyers and finishers of dress goods, men's wear, knit goods and yarns; 80 looms; steam; King & Beals, 51 Franklin St., N. Y, s. agts; G. H. Simonds and G. E. Foss, buyers. (Buy 2/14s to 2/40s, 1/14 to 1/36 worsted yarns.)

**NORTH ANDOVER SILK WIPING CLOTH** (**S**) Mfg. Co; M. F. Campbell & Co; Silk Noils, Yarn, Machine Cloths, Towels, etc; 4 looms; 1 set woolen cards.

**STEVENS, M. T. & SONS CO.;** \$600,000; N. (**W**) Stevens, pres.; M. T. Stevens, treas.; S. D. Stevens, asst. treas.; Main office, Representing Stevens Mills and Osgood Mills, No. Andover; Marland Mills, Andover; Stevens & Co., Haverhill, Mass., and Franklin Mills, Franklin Falls, N. H.; J. P. Stevens & Co., 23 Thomas St., N. Y., s. agts.

**OSGOOD MILLS.** See M. T. Stevens & (**W**) sons Co.; P. H. Yost, supt.; Dress Goods; 10 sets; 48 looms; steam and water; dye.

**STEVENS MILLS.** See M. T. Stevens & (**W**) Sons Co.; Carl Vetter, supt.; Dress Goods; 13 sets; 88 looms; water and steam; dye.

**No. Andover Depot.** B. 12. B. & M. RR., W. Div.

**LAWRENCE DYE WORKS CO. THE.** Removed to Lawrence, which see.

**SUTTON MILLS;** \$200,000; Wm. Sutton, (**W**) treas.; Harry Sutton, supt; Dress Goods

and Flannels; 12 sets; 72 looms; steam and water; dye; Deering, Milliken & Co., N. Y. and Boston, s. agts.

**No. Bellingham.** F.10. In Bellingham, N. Y. & N. E. RR.

CHARLES RIVER WOOLEN CO; \$96,000; (W) Wm. E. Hayward, pres; H. T. Hayward, treas; Geo. E. Duffy, agt. and supt; Suitings; Dress Goods, Overcoatings and Mellons; 10 sets; 132 looms; steam and water; dye; Mackintosh, Taft & McKenney, s. agts; Geo. E. Duffy, buyer. (Buy No 58 to 208 cotton warp.) (See Franklin, Mass., for Shoddy Mills.)

**No. Billerica.** C.11. B. & M. RR, So. Div.

FAULKNER MFG. CO; \$100,000; Geo. M. (W) Preston, pres. and treas; W. A. Evans, agt; Flannels and Dress Goods; 8 sets; 58 looms; water and steam; dye; Faulkner, Page & Co., N. Y. and Boston, s. agts; Geo. M. Preston, buyer.

HOCKADAY, ROBT.; Bicycle Hose, Half (K) Hose and Boy's hosiery; 1 knitting machine.

TALBOT MILLS; \$300,000; S. Lincoln, (W) pres; F. S. Clark, treas. and agt; Joseph F. Talbot, supt; Flannels, Dress Goods, Cheviots; 21 sets; 204 looms; water and steam; dye; Parker, Wilder & Co., N. Y. and Boston, s. agts; F. S. Clark, buyer.

**Northboro.** E.10. N. Y, N. H. & H. RR, No. Div.

See also Chapinville.

WOODSIDE MILLS; Est. of D. F. Wood; (W) Blankets and Satinets; 7 sets; 50 broad blanket, 46 satinnet looms; water and steam; dye. *Not running.*

**Northbridge.** F.10. N. Y, N. H. & H. RR, Wor. Div. See also Whitinsville.

RIVERDALE WOOLEN CO; (Inc. 1894); (W) \$150,000; M. B. Schwab, pres; Herman Rawitser, treas; Edw. Glueck, sec. and gen. mgr; Shoddies; 24 sets; 11 pickers; 2 garnett machines; dye; steam and water; sell direct. Edw. Glueck, buyer.

ROCKDALE MILL; Paul Whitin Mfg. Co; (C) \$250,000; G. M. Whitin, pres; H. T. Whitin, treas; H. S. Houghton, Jr, supt; Cambrics, Lawns, Sateens, Twills and Dobby Work; 29,150 ring and 23,175 mule spindles; 1240 looms; water and steam; sell direct.

**No. Chelmsford.** C.11. B. & M. RR, So. Div.

MOORE, GEO. C; John Connor, supt; (W) Fine Worsted and Carpet Yarns and Tops; Wool Scouring; 25,000 worsted spindles; 35 combs; 38 worsted cards; water and steam; sell direct. Also Westford.

SUCCESS WORSTED CO.; Geo. C. Moore, (W) treas.; D. W. Shirreffs, agt. and supt.; Serges, Clays, Cheviots, Fancy Worsteds; 34 looms; steam; finish; H. Lawton & Co., N. Y. and Boston, s. agts.; D. W. Shirreffs, buyer.

**No. Dana.** D.6. B. & A. RR, Athol Br.

CRAWFORD & TYLER; Children's Suit. (W) ings and Satinets; 2 sets; 24 looms; water and steam; dye; W. Stoney & Son, 132 Broadway, N. Y., s. agts.; either member firm buys. (Buy cotton warps, 14 to 22.)

**No. Dighton.** H.12. N. Y., N. H. & H. RR., Plym. Div.

MOUNT HOPE FINISHING CO.; \$115,000; (F) Joseph Knowles, pres.; Joseph K. Milliken, treas.

**No. Grafton.** E.9. B. & A. and G. & M. RRs.

GRAFTON FLAX MILL; Finlayson, Bous. (F) field Spinning Co.; Linen Thread; steam and water; The Linen Thread Co., s. agts.

HEFLAR, JOHN; Cotton and Wool Waste (W) and Shoddy; 3 pickers; steam and water.

PATON, WM. LTD; Gleniffer Mills; \$750.- (C) 000; James Paton, managing director; Geo. C. Paton, sec. and treas.; W. B. Shearer, agt. and buyer; Shoe Laces in Cords, Braids, Porpoise and Leather; steam; sell direct. (Buy 12s to 30s single and 16s to 60s two fold yarns).

**No. Oxford.** F.8. N. Y, N. H. & H. RR.

BARTLETT, EDWIN; E. N. Bartlett, supt; (C) Satinet Warps; 6000 ring spindles; water and steam; sell direct; owner and supt., buyers.

GLEN WOOLEN CO; \$35,000; P. H. Walsh, (W) supt. and buyer; All kinds Woolen Goods; 8 sets; 3,500 spindles; 40 looms; water; dye; sell direct.

OXFORD DYE WORKS; *Out of business.* (Mill leased by Thayer Woolen Co.)

TAFT, DAVID N; Lamb Mill; Satinets; (W) 288 woolen spindles; 1 set; 16 looms; steam and water; David N. Taft, buyer. Also see Oxford.

THAYER WOOLEN CO; \$25,000; Frederick (W) Thayer, pres. and treas.; L. F. Kilty, supt.; Cotton Warp Satinets; 8 sets; 104 looms; water and steam; dye; Bacon & Co, N. Y., s. agts.; Fred'k Thayer, buyer. Mill at Texas Station, B. & A. RR, Web. Br. Also mill at Worcester and 4 set mill at Dayville, Conn. (Operating 1 set cards; 14 looms in Michael Degnan's mill.)

**North Weymouth.** E-13. RR. Station East Weymouth N. Y., N. H. & H. RR.

BRAYSHAW, JAMES; Dolls and Large Ham-(C) mocks; 3 looms; hand power; E. I. Horsman Co., N. Y., s. agts. (Buy cotton yarns.)

**North Wilbraham.** F.6. B. & A. RR.

DAVIS, BOTTOM & Co; Shoddy and (W) Waste Dusters; water.

**Norton.** G.12. N. Y, N. H. & H. RR.

NORTON MILLS Co; \$20,000; C. R. Briggs, (W) pres; G. H. Talbot, treas; W. H. Talbot, supt; Wool Scouring; 40,000 lbs. per day; steam and water; Boston Office, 624 Atlantic Ave.

**Oakdale.** D.9. B. & M. RR, WN. & P. and Cent. Mass. Divs.

GLEN MILLS; Jas. F. Dorr, agt; Sati. (W) nets, Shirtings, Mellons and Skirtings; 4 sets; 1248 woolen spindles; 42 looms; water; dye; Bacon & Co, N. Y., s. agts.

GOULD MFG. Co. See Shirley, Mass.

WARFIELD, S. R; Warps; 3000 spindles; (C) 23 cards; water; sell direct.

WEST BOYLSTON MFG. Co. (Machinery moved to new mill at Easthampton.)

**Otter River.** C.8. Fitch RR.

RIVER MILLS; 6 sets; 21 looms; steam (W) and water; dye. Idle.

OTTER RIVER MILLS; (Leased by Whit. (W) ney Woolen Co); Yarns, 1 to 6Rs; 3 sets; 36 (idle) looms; water; dye; sell direct.

TEMPLETON MILLS; Henry C. Haile, (W) treas; Roscoe B. Stokes, supt; Woolen Yarns; 3 sets; 1200 woolen spindles; water and steam; dye; Greenley, Cushman, & Record, N. Y. Boston, Chicago and Phila, s. agts; Henry C. Haile, buyer.

**Oxford.** F.9. N. Y, N. H. & H. RR.

See also No. Oxford.

BUFFUMS' MILLS; 4 sets; 22 looms; steam (W) and water; dye. *Not running.*

HOWARTH, A. & SON; Oxford Woolen (W) Mills; Andrew P. Howarth, supt. and buyer; White Flannels; 5 sets; 32 looms; water; dye; Faulkner, Page & Co., N. Y. and Boston, s. agts. (also Rockdale, Mass.)

RICH, JOHN S.; Shoddy. (Branch mill). (W) See Millbury.

TAFT, DAVID N; Bernon Mill; Ar. (W) thur A. Cargel, supt; Satinets, Skirtings and Suitings; 3 sets; 864 woolen spindles;



- 42 looms; water and steam; S. H. & O. B. Newhouse, N. Y., s. agts; David N. Taft, buyer. Also at No. Oxford.
- Palmer.** F. G. B. & A. and Yt. Cent. RRs. See also Three Rivers and Bondsville.
- GROSVENOR WOOLEN CO.;** Mt. Bunyan (**W**) Mills; \$20,000; W. J. Stritche, pres. and mgr; Chas. F. Grosvenor, treas.; Shoddies and Extracts, Custom Carbonizing, Picking and Carding; steam and water; dye; sell direct; W. J. Stritche, buyer. (Also Holyoke, Mass.)
- HOLDEN & FULLER;** C. E. Fuller, (**W**) supt; Messrs. Holden & Fuller, buyers; Ladies' All Wool Dress Goods; 4 sets; 19 broad looms; steam; dye; sell direct and C. A. Auffmordt & Co. and Sack & Stasiaty, N. Y., s. agts.
- PALMER CARPET MFG. CO.;** \$25,000; M. J. (**W**) Whittall, pres. treas. and buyer; office in Worcester; Andrew Pinney, supt; Brussels Carpets; 24 looms; steam; dye; sell direct.
- THORNDIKE MFG. CO.;** See Thorndike, Mass.
- Peabody.** C. B. B. & M. RR, E. & So. Divs.
- DANVERS BLEACHERY & DYE (H & D** WORKS); Grant Walker, mgr; J. Howard Fallon, agt.; Bleaching, Dyeing and Finishing Cotton Piece Goods; steam; dye; capacity, 90 tons per week; Grant Walker, 92 State St., Boston, buyer.
- Pittsfield.** D. 2. B. & A. RR, and N. Y., N. H. & H. RR, Berk. Div.
- COLLINS, D. M. & Co.;** C. W. Power, (**K**) supt; Men's, Women's and Children's Knit Underwear; 32 knitting machines; steam; sell direct.
- HELLIWELL & Co.;** Cotton Warp Car. (**W**) rige, Cap and Casket Cloths; 4 sets; 60 looms; steam and water; dye; sell direct.
- MUSGROVE, CHAS. M.;** Ladies' and Chil. (**K**) dren's Knit Skirts, Knit Wash Cloths and Towels; 2 knitting and 5 sewing machines; sell direct.
- MUSGROVE KNITTING CO.;** \$12,000; Joseph (**K**) H. Wood, pres; J. H. Musgrove, treas. and mgr; Misses', Children's and Women's Ribbed Underwear; 10 machines; steam; sell direct.
- ORIENTAL SILK THREAD CO.;** Jas. C. Mac (**S**) Gowan, Jr., prop; Spool Silk for Tailoring and Clothing Trade; sell direct.
- PECK MFG. CO.;** J. L. & T. D.; \$150,000; (**C**) Mill No. 1; Cotton Warps; 7000 ring spindles; steam and water; dye.
- PECK MFG. CO.;** Mill No. 2; Thomas D. (**W**) Peck, pres; R. D. Gillett, treas; J. C. Thickens, supt; Men's Wear, Cassimeres; 17 sets; 176 narrow and 36 broad looms; steam and water; dye; Sawyer & Blake, N. Y., s. agts.
- PITTSFIELD MFG. CO.;** \$15,000; Jas. O. (**W**) Purnell, pres, treas. and agt; Woolen and Merino Yarns, 5 to 40 cut; 9 sets; steam; dye; sell direct.
- PITTSFIELD MFG. CO.;** Knitting Dept.; (**K**) Novelties in Mohair, Tam O'Shanters, Mittens, Toques, Hoods, etc.; 5 knitting machines; 2 looms; steam; dye; sell direct.
- POMEROY WOOLEN CO.;** Upper Mill; (**W**) T. L. Pomeroy, pres; 8 sets; 32 looms; steam and water; dye. *Not running.*
- POSTOUSUC WOOLEN MFG. CO.;** \$240,000; (**W**) W. R. Plunkett, pres; Geo. Humphrey, treas; H. A. Francis, agt. and supt; Blankets, Carriage Robes, Suitings and Cloakings; 22 sets; 100 looms; water and steam; dye; Fisher & Francis, 60 Leonard St., N. Y., s. agts.
- RICE, A. H. & Co.;** Silk Thread and Silk (**S**) and Mohair Braids; 800 braiders; steam; dye; sell direct.
- RUSSELL MFG. CO., S. N. & C.;** \$100,000; (**W**) F. W. Russell, pres; Henry R. Russell, treas. and sec; Isaac E. Wittan, supt; Carriage Cloth, Thibets, Dress Goods and Kerseys; 14 sets; 70 looms; steam and water; dye; Stevens, Sanford & Handy, 47 Worth St., N. Y., s. agts; F. W. & H. R. Russell, buyers.
- TACONIC MILLS;** James Wilson, prop; (**W**) R. A. Scuple, supt.; Cassimeres and Cloakings; 17 sets; 80 looms; steam; dye; Sullivan, Vail & Co., and Hoffman & Cross, N. Y., s. agts.
- TILLOTSON MFG. CO.;** \$175,000; W. E. Til- (**W**) lotson, pres; W. L. Scarles, treas.; Worsted Suitings and Woolen and Worsted Yarns; 12 sets; 3 combs; 4536 worsted spindles; 103 looms; steam and water; dye; sell direct.
- WOOD, S. C.;** 40 Stoddard Ave. Elastic (**K**) Bandages, Stockings, etc; 3 knitting machines.
- Plymouth.** G. 15. N. Y., N. H. & H. RR, Plym. Div.
- MABBETT, GEO. & SONS.;** H. E. Mabbett, (**W**) supt. and buyer; Worsted Cloths; 22 looms; electricity; dye; sell direct. (Buy worsted yarns, 2/10s to 2/80s).
- PLYMOUTH CORIAGE CO.;** \$1,000,000; Au- (**J**) gustus P. Loring, pres; G. F. Holmes, treas; R. A. Brown, supt; Corlage and Binders' Twines; steam; sell direct. (No. Plymouth, Mass.)
- PLYMOUTH WOOLEN & COTTON COMPANY.;** (**C**) \$50,000; Albert Hayden, pres; Horace Loring (Boston), treas; Leander M. Vaughn, supt; Sail Duck; 1408 ring spindles; 11 narrow and 4 broad looms; water; Horace Loring, buyer; water; Hall, Lincoln & Co., s. agts.
- PURITAN WOOLEN MILLS (American (W** Woolen Co.); W. M. Wood, (Boston,) treas; Otis P. Wood, agt; Woolen and Worsted Goods for Men's Wear; 162 looms; steam; dye; J. C. Woodhull, N. Y., s. agt; H. J. Potter, (Boston,) buyer.
- STANDISH WORSTED CO.;** \$240,000; B. F. (**W**) Mellor, pres. and mgr.; F. E. Anderson, (N. Y.,) treas. and agt; High Grade Worsted Cloths for Men's Wear; steam and water; dye; 60 broad and 8 narrow looms; sell direct; B. F. Mellor, buyer. (Buy fine Botany, 2/70s to 1/4 blood 2/10s.)
- Quinapoxet.** D. 9. B. & M. RR, Cent. Mass. Div.
- WOOD, CYRUS G. & Co.;** Satinets; 10 (**W**) sets; 120 looms; water and steam; Bacon & Co., N. Y., s. agts.
- Quincy.** E. 13. See Braintree.
- Readville.** E. 2. N. Y., N. H. & H. RRs.
- KNIGHT, ROBT.;** (Prov. R. 1.); Readville (**C**) Cotton Mills; T. Burt Stevenson, supt; Fine Sheeting, Shirtings and Twills; 10,720 ring and 8,064 mule spindles; 500 looms; steam and water; P. O. address Hyde Park.
- Rochdale.** F. 8. B. & A. RR.
- CARLETON, E. G. & SONS.;** White Flan- (**W**) nels; 4 sets; 28 looms; water and steam; sell direct; Everett Carleton, buyer.
- CLARK, J. D. Co.;** \$20,000; I. E. Comins, (**W**) pres; A. C. Comins, treas; Cotton Warp Clothing, Cloaking and Dress Goods; 4 sets; 48 looms; water and steam; S. H. & O. B. Newhouse, s. agts; A. C. Comins' buyer.
- COMINS & Co.;** I. E. Comins, supt; Cotton (**W**) Warp Meltons and Chevots; 3 sets; 40 looms; water and steam; S. H. & O. B. Newhouse, Dept., Fleitmann & Co., N. Y., s. agts.; I. E. Comins, buyer.

- HOWARTH, A., & SON: Rochdale Woolen (**W**) Mills; Benj. Simmons, supt.; Flannels, Dress Goods, etc.; 9 sets; 47 looms; steam and water; dye; Faulkner, Page & Co., N. Y. and Boston, s. agts. Also mills at Oxford.
- WARP KNITTING MILL; J. E. Fenner, (**K**) agt., supt. and buyer; All kinds of Hosiery; 12 knitting machines; 4 sewing machines and loopers; steam; sell direct; (buy 10s to 40s single yarn; cotton wool, merino and silk.)
- Rockland.** F.13. N. Y., N. H. & H. RR.
- ROCKLAND WEBBING CO.; \$25,000; Elisha (**C**) T. Harvell, pres.; Joseph E. French, treas.; Geo. A. Woodward, agt. and buyer; Harry Woodward, supt.; Tapes, Shoe Strapping, Non-Elastic Narrow Fabrics; 10 looms; steam.
- Royalston.** C-7. See So. Royalston.
- Rutland.** D-8. B. & M. RR, Cent. Mass Div.
- McGANN, O. W.; Shoddy. Mill at No. (**W**) Rutland.)
- STANDARD WOOLEN Co. (formerly Moul. (**C**) ton Bros.); Satinets; 1 set; 12 looms; dye; Sawyer & Blake, s. agts.; (P. O. address, No. Rutland.)
- Salem.** C-13. B. & M. RR, E. and So. Divs.
- NAUMKEAG STEAM COTTON CO.; \$1,500,000; (**C**) David Pingree, pres.; N. G. Simonds, treas.; Wm. P. McMullan, agt.; Sheetings, Jeans, Satinets, Drillings and Shirtings; 75,504 ring and 29,352 mule spindles; 2,900 looms; steam; Parker, Wilder & Co., N. Y. and Boston, s. agts.; Wm. P. McMullan, buyer.
- SALEM WASTE CO.; F. P. Symonds, treas. (**C**) and agt.; Cotton Wiping and Mop Waste; steam; F. P. Symonds, buyer.
- Sandwich.** J-15. N. Y., N. H. & H. RR, Cape Cod Div.
- ARMSTRONG BRAIDING CO.; \$30,000; A. H. (**S**) Armstrong, pres.; H. L. Harding, (Boston.) treas.; Silk Watch Guards, Vest Chains, Fobs, Eye Glass Cords, etc.; 100 braiders; steam; sell direct.
- UNION BRAIDING CO.; W. H. Heald, agt. (**S**) and supt.; Silk and Mohair Braid; Silk Vest Chains, Cords, Guards, etc.; 200 spinning spindles; 6875 braider spindles; water; sell direct; W. H. Heald, buyer. (Buy raw silk No. 1 Jap. fil 14/16 denier, black glazed cotton, fine, and coarse and 1 am and orgazine silks.)
- Saugus.** D-13. B. & M. RR, E. Div.
- SAPGUS WOOLEN MFG. Co., (Incorpo- (**W**) rated.) Pranker Mill; 11 sets; 70 looms; water and steam; dye. *Not running.*
- SCOTT, F., & SON; Dress Goods; 5 sets; (**W**) 33 looms; water and steam; dye; Faulkner, Page & Co., N. Y. and Boston, s. agts.; Walter Scott, buyer.
- Saundersville.** F-9. N. Y., N. H. & H. RR, Wor. Div.
- SAUNDERS COTTON MILLS; \$175,000; (**C** & **S**) Arthur F. Whitin, pres.; Edw. Whitin, treas.; Thos. Wilmarth, supt.; Fine Shirtings and Satinets; 7680 ring and 5,888 mule spindles; 356 looms; steam and water; Whitin & Collins, 112 Worth St., N. Y., s. agts.; Edw. Whitin, buyer.
- Saxtonville.** E-10. In Framingham, B. & A. RR.
- SAXONVILLE MILL; \$80,000; Frank E. (**W**) Dawson, pres.; Wm. Butler, treas.; Robt. Dawson, agt.; Fred R. Dawson, supt.; Worsted and Woolen Yarns; Wool Blankets, Cassimeres and Medium Clothing; 24 worsted sets, 6,600 worsted spindles; 12 combs. (Bradford system); 4 woolen sets; 100 looms; steam and water; dye; sell direct. Office, 93 Summer St., Boston.
- Shattuckville.** C-4. On line electric cars from Shelburne Falls to Colrain.
- MASSAEMET YARN MILLS; \$50,000; S. T. (**C**) Field, pres.; C. L. Field, treas.; F. S. Field, supt.; Yarns; 40s to 60s; 3,000 ring and 4,000 mule spindles; water and steam; sell direct.
- Shelburne Falls.** C-4. In Shelburne, Fitch. RR.
- FARLEY, D. E. (Branch mill); 20 knit- (**K**) ting machines. (See Farley, Mass.)
- Shirley.** C-9. Fitchburg RR.
- EDGARTON MFG. CO, THE C. A.; \$50,000; (**C**) C. F. Edgerton, pres. and treas.; Suspender Webs and Suspenders; steam; sell direct; N. Y. office, 256 Church St.; C. F. Edgerton, buyer. (Buy silk and cotton yarns.)
- GOULD MFG. CO. (successors to S. Gold. (**W**) stein & Co.); \$10,000; S. Kronberg, pres.; S. Gould, treas.; Shoddy and Flocks; 5 pickers; 2 cutters; water; sell direct; S. Gould, buyer.
- SAMSON CORDAGE WORKS; \$200,000; J. P. (**C**) Tolman, pres.; H. G. Pratt, treas.; J. P. Tolman, mgr.; Newton Wilson, supt.; Braided Cords and Cotton Twines; 3,000 spindles; 300 braiding machines; water and steam; sell direct. Office, 15 Congress St., Boston, 90 Chambers St., N. Y., 142 Lake St., Chicago, and 23 Davis St., San Francisco. J. P. Tolman, buyer. (Buy yarn s to 40.)
- WEEKS, F. D., EXTRACTING CO.; \$5,000; (**W**) F. D. Weeks, pres. treas. and agt.; Chas. Steere, supt.; Wool Extracts; Custom Carbonizing; steam and water; sell direct; F. D. Weeks, buyer.
- Smith's.** E-5. B. & A. RR.
- SWIFT RIVER CO.; \$37,000; E. P. Smith, (**W**) pres. and treas.; H. M. Smith, agt.; A. Hess, supt.; Fancy Cassimeres; 8 sets; 35 looms; steam and water; dye; Wendell Fay & Co., N. Y., s. agts.; H. M. Smith, buyer.
- Smithville.** D-7. Stations, Barre on B. & M. RR, Cent. Mass. Div., and Colebrook, on B. & A. RR.
- WHITE VALLEY MILLS; White Bros. (**C**) (Winchendon, Mass.); Z. L. White, pres.; J. N. White, treas.; Thos. J. Hoban, supt.; Cotton Denims; 4240 ring spindles; 128 looms; water; dye; sell direct; Z. L. White, buyer. (Purchased Barre Cotton Mill.) P. O. address White Valley.
- Somerville.** D-12. B. & M. RR, and Fitch. RR.
- MIDDLESEX BLEACH, DYE & (**Bl. Pr** & **D**) PRINT WORKS; K. M. Gilmore & Co.; Geo. L. Gilmore, agt., supt. and buyer; Cotton Goods; steam. (Freight address, Boston.)
- So. Acton.** D-10. Fitch. RR.
- SOUTH ACTON WOOLEN CO.; Fred H. (**W**) Rawitzer; Shoddy and Wool Extracts; 5 sets; 2 pickers; water and steam; dye and carbonizing; sell direct.
- Southbridge.** G-8. N. Y. & N. E. RR.
- See also Globe Village.
- CENTRAL MILLS CO.; \$150,000; Geo. W. (**C**) Wells, pres.; Calvin D. Paige, treas.; O. B. Gay, supt.; Cotton Sheetting and Twines; 12,000 ring spindles; 360 looms; water; Converse, Stanton & Co., N. Y. and Boston, and J. H. Lane & Co., s. agts.; C. D. Paige, buyer.
- SOUTHBRIDGE PRINTING CO.; \$25,000; (**Pr** & **F**) J. H. Sanders, pres. and supt.; Thos. Sanders, treas.; Bleaching, Dyeing, Printing and Finishing Cotton Goods; 9 printing machines; steam and water; dye; James L. Brown, soliciting agt.; Thos. Sanders, buyer.

**So. Groveland.** B-13. In Groveland, on B. & M. RR, W. Div.

VEASEY & HALE; Groveland Mills; A. (W D. Veasey, supt; Dress Goods and Flannels; 41 sets; 254 looms; steam and water; dye; Fred'k Viator & Achelis, N. Y. s. agts.

**So. Hadley Falls.** F-5. Stage at Holyoke, on B. & M. RR, Conn. R. Div. and N. Y., N. H. & H. RR, Northampton Div.

GLASGOW MFG. CO.; Cotton Dress Goods, (C Flannelettes, etc.; 13,000 spindles; 475 looms; water and steam; dye; Treat & Converse, s. agts. (Operated by receivers.)

**So. Royalston.** C-7. Station, Royalston, on Fitch. RR.

WHITNEY WOOLEN CO, GEO; \$50,000; Geo. (W E. Whitney, pres., and treas.; E. B. Hanson agt.; Joseph Beaumont, supt.; Yarns; 11 sets; water and steam; dye; sell direct; Geo. E. Whitney, buyer.

**Spencer.** E-S. B. & A. RR.

BEEBE, WEBBER & CO; Woolens and (W Worsted; 3 sets; 18 looms; water; dye. (Main mill and buying at Holyoke.)

DUFFON BROS; Westville Mill; Sat. (W inets; 2 sets; 24 looms; steam and water; dye.

LEAVITT WOOLEN MILL; H. C. Leavitt, (W prop.; 3 sets; 42 looms. (Operating Red Mill.)

SPENCER TEXTILE CO. *Out of existence.*

TAFT, A. L.; Sateinets; 3 sets; 864 mule (W spindles; 48 looms; steam and water; dye; sell on contract; A. L. Taft, buyer.

**Springfield.** F-5. B. & A, N. Y., N. H. & H. & B. & M. RRS.

HUTCHINS NARROW FABRIC CO; (C & S \$40,000; 140 Wilbraham Ave.; G. R. Bond, pres.; E. W. Bond, treas. and mgr.; C. D. Bond, sec; Spool Tapes, Narrow Elastic Webs, Stay Bandages and Braid, etc; 176 looms; steam; sell direct; E. W. Bond, buyer.

MEDICOTT, MORGAN CO; \$15,000; Jas. C. (K Cooley, pres.; H. M. Morgan, treas. and buyer; Men's Fancy Cotton Underwear; Balbriggans, Lisle Thread, Mercerized; 60 cylinders; steam; dye; Knower & Turnbull, N. Y., s. agts.; H. M. Morgan, buyer. (Buy combed Egyptian and peeler yarns, also mercerized and Sea Island 10/1 to 100/2.)

RICHARDS, FRED J; (successor to Church (C & Richards); Mops, Cotton Wicks, (Torch and Miners,) Mattress and Quilt Stock, Spun Cotton; 500 spindles; water and electricity; sell direct.

SPRINGFIELD BRAID CO; Taylor & (S & W Hubbard; 54 Taylor St; Mohair and Silk Braid and Silk Cord in Black; 90 braiders; steam; sell direct.

SPRINGFIELD KNITTING CO; (Inc. 1892); (K 32 Taylor St; \$200,000; Gordon Bill, pres; N. D. Bill, treas; C. B. Potter, agt; Infants', Children's and Ladies' Ribbed and Men's Flat Underwear; 4 sets; 3,000 cotton spindles; 200 knitting machines; steam; dye; sell direct; C. B. Potter, buyer.

SPRINGFIELD WASTE CO; Mill St; \$150,000 (C Geo. E. Howard, pres. and treas; A. H. Watson, supt; Machine Waste; 7 pickers; water.

SPRINGFIELD WEBBING CO; \$15,000; Jos. (C Merriam, pres; L. F. Denio, treas; Cotton Webbing and Tapes; 62 looms; water; sell direct; L. F. Denio, buyer (Buy yarn.)

SPRINGFIELD FELTING CO; Felting. (W

WHITTIER MILLS; \$70,000; Nelson (C & D Whittier, treas.; Walter R. B. Whittier, mgr.; Fire Hose Cords, Cotton Yarns Warps and Specialties; also dyers of yarn; sell direct. (Mills at Chatahochee, Ga., which see.) (See advertisement.)

**Stoughton.** F-12. N. Y., N. H. & H. RR, Prov. and Taunt. Divs.

FRENCH & WARD; Thos. Blanchard, (W & K sup; Elderdown and Flannels; 8 sets; 36 looms; 52 knitting machines; water and steam; dye; sell direct; A. E. French, buyer. (Buy 1/22 cotton and 1/18 yarn.)

STOUGHTON MILLS. See West Stoughton.

STRETTON, CHAS. & SONS; Jersey Knit (K Underwear and Fancy Knit Goods; 75 knitting machines; 80 finishing machines; steam; sell direct; Thos. Stretton, buyer.

**Sutton.** F-9. See Manchaug and Wilkinsonville.

**Taunton.** H-12. N. Y., N. H. & H. RR, Taunt. Div.

CANOE RIVER MILLS; John C. Sharp, (C Jr., treas.; J. W. Taylor, agt., supt. and buyer; Yarns Combed, Carded, etc., 30s to 100s; 21,000 ring spindles; steam; J. E. Mitchell & Co., Phila. and Boston, s. agts.

COHANNET MILLS; (New England Cotton (C Yarn Co.) steam; sell direct. (See New Bedford for officers, etc.)

CORR MFG. CO; \$500,000; P. H. Corr, pres; (C H. H. Shumway, treas, agt. and supt; Plain and Fancy Cotton Cloths; 40,352 ring spindles; 4200 looms; steam; sell direct; H. H. Shumway, buyer.

ELIZABETH POOLE MILLS; \$100,000; Wm. (C C. Lovering, pres; A. E. Swasey, treas; H. H. Culver, supt; Wash Fabrics and Varieties of Napped Goods; 768 ring and 1408 mule spindles; 336 looms; steam; Faulkner, Page & Co., N. Y. and Boston, s. agts; Albert E. Swasey, buyer.

HOPEWELL MILLS; L. Beebe & Co.; (C Boston; 11,600 spindles; 280 looms; water and steam. *Closed indefinitely.*

NEMASKET MILLS; New England Cotton (C Yarn Co.) Yarns; steam and water; sell direct. (See New Bedford for officers, etc.)

OAKLAND MILLS; \$80,000; J. Howard Tidd, (C pres.; Joseph S. Tidd, treas. and agt.; John Fring, supt; Denims and Tickings; 3500 ring and 2000 mule spindles; 160 looms; water and steam; dye; Faulkner, Page & Co, N. Y. and Boston, s. agts; J. S. Tidd, buyer. (Buy warp No. 10, cop. No. 22.)

SAFETY SEAMLESS POCKET CO; Mason (C Machine Works, Trustee; A. C. Bent, agt; Seamless Pockets and Bags; 100 looms; electric power; sell direct. (Buy 11/1-12/1 Cop Filling and 9/1 16/1 Warp.)

SEGREGANSETT KNITTING MILL. *Prop. (K posed.*

TAUNTON DYEWORKS & BLEACHERY (BI & D Co. (Inc. 1893); \$21,000; Henry M. Lovering, pres; W. M. Lovering, treas; Wm. E. Emery, supt; water and steam; Dyed Cotton and Yarn, White Carded Cotton, Dyed and White Cotton Warps.

WHITTENTON MFG. CO; \$600,000; Wm. C. (C Lovering, pres; Chas. L. Lovering, treas; H. M. Lovering, agt; Wm. M. Lovering, supt; Shirts, Blankets, Cottonades, Colored Napped Fabrics; 42,000 ring spindles; 1650 looms; steam and water; dye; Faulkner, Page & Co, N. Y. and Boston, s. agts.

WINTHROP MILL; \$200,000; C. L. Macomber, pres; Abbott F. Lawrence, treas; Orville Macomber, supt; Combed Yarns; 12,000 spindles; steam; sell direct.

**Templeton.** C-7. See Otter River.

**Thorndike.** F-6. B. & A. RR. 6 M. from Palmer.

THORNDIKE CO; \$675,000; Chas. H. Fiske, (C pres.; P. Olsen, treas; Chas. H. Hobbs, agt; Tickings, Denims, Cottonades, Awnings, etc; 37,728 ring spindles; 861 looms; water and steam; dye; Bliss, Fabyan & Co, N. Y., Boston and Phila. s. agts. *Also West Warren, Mass.*

**Three Rivers.** F.6. B. & A. RR, Athol Br. and Cent. Vt. RR.

**PALMER MILL OF THE OTIS CO;** Geo. F. (C) Fabyan, treas.; R. C. Newell, supt.; Seersuckers, Fancy Denims, Covert Cloths, Shirtings; 23,126 ring and 9600 mule spindles; 912 looms; water and steam; dye; Bliss, Fabyan & Co., N. Y., Boston, and Phila., s. agts. See also Ware.

**Turner's Falls.** C.5. N. Y. N. H. & H. RR, Northampton Div.; Fitch. RR; Stage from Greenfield on B. & M. RR, Conn. Riv. Div.

**TURNER'S FALLS COTTON MILLS;** E. D. (C) Griswold, pres.; Lorenzo Griswold, treas.; Frank D. Griswold, agt.; Sheatings and Shirtings; 12,000 spindles; 320 looms; steam and water; sell direct; N. Y. office, 51 Leonard St.

**Uxbridge.** F.10. N. Y. N. H. & H. RR, Wor. Div.

**CALUMET & HECLA MILLS;** Calumet (W) Woolen Co; \$300,000; Hales W. Suter, pres.; Arthur Wheelock, treas. and agt.; All Wool Cassimeres, Overcoatings, Worsteds, Kerseys; 20 sets; 90 looms; water and steam; dye; Jacob Wendell & Co., N. Y., agts. (Buy 2/30 and 2/50 in mixtures and white.)

**CAPRON SATINET MILL;** 1440 spindles; 5 (W) sets; steam and water. *Not running.*

**HAPPY HOLLOW MILL;** 3 sets; 24 looms; (W) water; dye; Mill at South Uxbridge. *Mill idle.*

**IRONSTONE WOOLEN CO.;** Albert E. Davis, (W) pres.; Albert E. Davis, Jr., supt.; Sackings, Repellents, Skirtings and Meltons, 10 looms; steam and water. Forstman & Co., N. Y., a. agts.; A. E. Davis, buyer. (Buy 20s and 24s cotton warps, woolen and merino yarns, 1 1/2 run to 3 run.) P. O. Address Millville, Mass.

**LEE, D. M.;** Shoddy and Flocks; 2 pick. (W) ers.

**MUMFORD RIVER TAPE CO.;** H. E. Sweet, (C) treas. and buyer; W. H. Sweet, supt.; Tapes and Narrow Ribbons; 8 looms; steam; Glidden & Co., Boston, s. agts. (Start Feb. 15th.)

**ROOT, C. A. & CO.;** Wancantuck Mills; (W) C. A. Root, supt. and buyer; Worsteds and Cotton Worsteds; 5 sets (not in use); 1 narrow and 24 broad looms; steam and water; dye (not used); L. Bachman & Co., s. agts. (Buy 2/18 to 2/50 worsted and 2/12 to 2/40 cotton yarn.)

**SAYLES, RICHARD & CO.;** Rivulet Mills; (W) John E. Sayles, supt.; Cotton Warp Woolens; 4 sets; 52 looms; water and steam; dye; Stevens, Sanford & Handy, N. Y., s. agts.

**SCOTT, J. R. & C. W.;** (formerly at Worees. (W) ter); Suitings and Dress Goods; 5 sets; 32 looms; water; Battelle, Hurd & Co., N. Y. and Boston, s. agts.; J. R. Scott, buyer. (Operating one of the Capron mills.)

**SCOTT, S. F.;** W. S. Hobbs, supt.; Satinets; (W) 4 sets; 56 looms; steam and water; Bacon & Co., N. Y., s. agts.; buy No. 16 cotton and 3 run wool.

**UXBRIDGE COTTON MILL;** See Whitins (C) ville.

**Wakefield.** D-12. B. & M. RR, W. Div.

**WINSHIP, BOIT & CO.;** Harvard Knitting (K) Mill; Ladies' and Misses' Jersey Underwear; 200 knitting machines; steam; Wm. Iselin & Co., N. Y., s. agts.; C. N. Winship, buyer yarns; Miss Boit, trimmings, etc. (Buy yarn 19, 10, 10 1/2, 11, 36, 28, 32 and 2/50, 2 60, 2/70, 2 80 combed peeler.)

**Wales.** G.7. Stage at Palmer on Cent. Vt and B. & A. RRs.

**BERKELEY WOOLEN MILLS;** Herbert E. (W) Shaw, prop.; A. A. Hubbard, supt.; Over

coatings and Cloakings; 4 sets; 21 looms; water and steam; dye; H. A. Caesar & Co., N. Y., s. agts.; H. E. Shaw, buyer.

**GOLDEN ROD MILL;** L. R. Rosenberg (W) and J. H. London; Kerseys, Cloakings and Cassimeres; 4 sets; 25 looms; steam and water; dye; Fleitman & Co., N. Y., s. agts. (See also Monson.)

**SHAW MILLS;** 3 sets; 14 looms; steam (W) and water; dye. *Not running.* For sale.

**Walnut Hill.** E-12. See Dedham.

**Walpole.** F-12. N. Y. & N. E. RR, and N. Y. N. H. & H. RR, Nor. Div.

**ALLEN, J. & S.;** Silk, Linen and Cotton (F) Lines and Linen Harness Twine; sell direct.

**GRAY, S. & CO THE.;** Walpole Dye (B) & D and Bleach Works; \$30,000; R. S. Gray, pres. and treas.; J. S. Leach, sec. and supt.; Cotton Threads, Yarns, Tapes, Twines, etc.; steam; capacity 10,000 lbs. fancy colors per day; mercerizing, spooling, coning yarns, etc.

**LEWIS BATTING CO.;** \$50,000; H. H. (C) Sanderson, pres. and treas.; Wm. Moore, supt.; Cotton Batts, Wadding, Carpet Lining, Stair Pads, Novelty Rugs; also Absorbent Gauze and Cotton; 40 cards; steam and water; dye; sell direct; G. F. Allen and Wm. Moore, buyers.

**LEWIS, BRADFORD & SON.;** Cotton Wip. (C) ing Waste; steam.

**MARCUS, M. H. & BRO.;** Baltimore Steam (C) Quilt Works; Cotton Bats, Bed Comfortables, Stair Pads; 25 cards; steam; sell direct, 115 Worth St., N. Y. and Balto.

**Waltham.** D-12. Fitch. RR, and B. & M. RR, Cent. Mass. Div.

**AMERICAN KNITTING CO.,** West Dale St.; (K) A. Tomlin, treas.; Childrens' Seamless Hosiery and Underwear; 24 knitting machines; sell direct and M. E. Slocum, Boston, s. agt. (Buy w. and wd. yarn.)

**BOSTON MFG. CO.;** \$400,000; Francis I. (C) Amory, pres.; Arthur T. Lyman, treas.; A. H. Gulliver, agt.; Wide Sheetings, Satens, Fine Colored Fancy Wash Goods and Hosiery; 33,888 mule and 19,664 ring spindles; 1474 looms; steam and water; dye; Lawrence & Co., Boston and New York, s. agts.; A. H. Gulliver, buyer. (Buy some mercerized yarns in skeins and warps.)

**COLLINS & HARDING.;** West Dale St.; (K) Knit Goods, Worsted and Wool Sweaters, Base Ball Stockings, Jersey Tights, French Knit Bicycle Suits; steam; sell direct; C. C. Collins, buyer. (Buy 2/13 worsted yarns, 2/18 woolen yarns.)

**ELLIOTT, FRED'K. & CO** (214 School St.); (K) Sporting Goods, Gloves, Mittens, Ladies' Hosiery, Cardigans, etc.; sell direct. (Buy 2/26s, 2/13s, worsted, 2/16s wool, 2/16s silk, 2/20s mercerized yarns.)

**WALTHAM BLEACHERY & DYE** (B) & D Works; \$480,000; Francis I. Amory, pres.; A. T. Lyman, treas.; G. E. Jordan, agt.; G. E. Getchell, supt.; Cotton Piece Goods; steam; Geo. E. Jordan, buyer.

**Ware.** E.7. B. & A. RR, and B. & M. RR, Cent. Mass. Div.

**GEO. H. GILBERT MFG. CO.;** \$1,000,000; (W) Lewis N. Gilbert, pres.; Edward H. Gilbert, vice-pres.; J. H. G. Gilbert, treas.; A. B. Paton, supt.; Men's Wear, and Ladies' Dress Goods; 7 combs; 28 sets woolen, 9 sets worsted; 11,530 woolen and 7,728 worsted spindles; 405 looms; water and steam; dye; Oelbermann, Dommerich & Co., N. Y., s. agts.; Geo. G. Levitt, company representative, 67 Worth St., N. Y.

OTIS CO; \$800,000; G. F. Fabyan, treas; (C & K) G. E. Tucker, agt; E. E. Orrell, supt; Checks, Denims and Fine Cotton Underwear; 57,000 spindles; 1000 looms; 1000 knitting heads; water and steam; dye; Bliss, Fabyan & Co, N. Y., Boston and Phila, s. agts. (also Three Rivers.)

STEVENS, CHAS. A. & Co; Ware Woolen (W) Mills; Joseph H. Walker, supt; Dress Goods and Flannels; 16 sets; 104 looms; water and steam; Parker, Wilder & Co, N. Y. and Boston, s. agts. Chas. E. Stevens, buyer. (Buy worsted yarn.)

**Warren.** F.7. B. & A. RR.

BRADFORD YARN MILLS; James E. Miller, pres, and treas; Woolen Yarn, Custom Work and Gaiting; 1300 spindles; 3 sets; water; sell direct.

SAYLES & JENKS MFG. CO; \$200,000; F. (W) L. Sayles, pres; W. A. Jenks, treas, and agt; G. W. Field, supt; Men's Wear, Kerseys, Worsted and Cassimeres; 9 sets; 90 looms; steam and water; dye; Kumbhardt & Stockton, s. agts; W. A. Jenks, buyer. (Buy all kind worsted yarn from 2/14 to 2/50.)

See also West Warren.

**Watertown.** D-12. Fitch. RR.

AETNA MILLS; \$250,000; M. A. Smith, (W) (Boston), treas.; A. O. Davidson, agt; Cassimeres, Cloakings and Ladies' Dress Goods; 15 sets; 105 looms; steam and water; dye; sell direct; N. Y. office 49 Leonard St.

DALBY THOS, Co; see Newton. (K)

UNION CARPET LINING CO. (179 Devon. (C) shire St., Boston); \$250,000; Sam'l A. Carlton, pres.; Joseph N. Damon, treas.; John M. Whittemore, gen'l mgr.; Carpet Linings, Stair Pads, Camels' Hair Shoddy and Bed Comfortables; steam; sell direct; Joseph N. Damon and John M. Whittemore, buyers.

**Webster.** G-8. N. Y., N. H. & H. and B. & A. RRs.

CHASE WOOLEN MILLS; (American (W) Woolen Co.) W. M. Wood, (Boston) treas; Prentiss Howard, agt; Fancy Worsteds and Cassimeres; 14 sets; 133 looms; steam and water; water; dye; J. C. Woodhull, N. Y., s. agt; H. J. Potter, (Boston,) buyer.

PERRY, JOSIAH; E. G. Parsons, supt. (W) and buyer; Fancy Cassimeres; 8 sets; 46 looms; water and steam; dye; Duval & Cone, N. Y., s. agts.

PERRY YARN MILLS; H. E. Smith, 2nd., (W) treas.; L. D. Perry, gen'l mgr.; Woolen and Merino Yarns; 6 sets; 4,000 spindles; steam; sell direct.

SLATER CAMBIC WORKS. See East Webster.

SLATER, H. N., EST. OF; W. J. Stewart, (C) supt; Sateens, Silesias and Sheetings; 91,000 ring spindles; 2,200 looms; water and steam, dye; S. Slater & Sons, N. Y. and Boston, s. agts; F. B. Smith, buyer.

SLATER WOOLEN CO; \$500,000; Aimos (W) Bartlett, pres, treas, and agt; Flannels, Broadcloths, Suitings; etc; 50 sets; 334 looms; water and steam; dye; S. Slater & Sons, 47-49 Worth St, N. Y., 77 Bedford St, Boston, 185 Van Buren St, Chicago, s. agts.

STEVENS, EBEN S; Cotton Warp Men's (W) Wear; 3 sets; 40 looms; steam. See also at *Quinebaug, Conn., where all bu. iness is done.*

STEVENS LINEN WORKS; \$350,000; M. T. (F) Stevens, pres; Henry S. Shaw, (Boston), treas.; E. P. Morton, agt; Crash Toweling; 7,500 spindles; 650 looms; steam and water; The Nevins Co, Boston, s. agts; Henry S. Shaw, buyer.

**Westboro.** E-10. N. Y. C. & H. R. RR.

WESTBORO WEAVING CO.; \$25,000; J. S. (C) Mason, agt, and buyer; Narrow Fabrics; 20 looms; steam.

**West Chelmsford.** C-II. B. & M. RR.

SUGDEN PRESS BAGGING CO; Donald (W) Cameron, mgr; Thos. Brown, supt; Camels' Hair Press Cloth; 12 looms; water; sell direct; Donald Cameron, buyer.

**Westfield.** F.4. B. & A. RR, N. Y., N. H. & H. RR, Northampton Div.

AUSTIN, R. H; Whip Snaps; sell direct. (C) Purchased plant of S. Elmer, Shelburne Falls.

CRESSY THREAD CO; See Holyoke, Mass.

SALMON, WM.; (136 Greene St., N. Y.) (C & S) Cotton and Silk Braids; steam; sell direct and Geo. W. Chapin, Phila., and E. H. Wangelin & Co., St. Louis, s. agts.; Wm. Salmon, buyer. (Also see New York.)

SMITH, EDWIN L. (West Springfield); (C) To form company and erect a new building for manufacturing all kinds of Thread. *Proposed.*

WARREN W. THREAD WORKS; \$200,000; (C & D) Wm. Warren, pres; Frank L. Worthy, treas.; James Harries, supt.; Spool Cotton and Threads for Manufacturers; water and steam; dye and bleach; capacity dye house, 4000 lbs; bleachery, 2000 lbs; sell direct.

WESTFIELD MFG. CO. (Reported petitioned into bankruptcy.)

**Westford.** C-10. B. & M. RR, So. Div, C. & M. RR, N. A. & B. Br.

MOORE, GEO. C; G. A. Moore, supt; Car. (W) pet Yarns; 6 combs; 6,000 spindles; steam and water; sell direct. Also No. Chelmsford.

**West Millbury.** F-9. B. & A. RR, N. Y., N. H. & H. RR, Wor. Div.

CRANE, B. F.; Wool Waste and Shoddy. (W) LOWENTHAL W.; Ramshorn Mills; (for (W) merly Ramshorn Mfg. Co.); C. E. Hoyle, supt.; Fancy Cassimeres, Overcoatings, Shirtings, etc.; 4 sets; 18 broad looms; water and steam; dye; sell direct; Wm. Lowenthal and C. E. Hoyle, buyers.

WINDLE, A. D. & W. W.; W. W. (W & D) Windle, prop.; Scouring, Carbonizing Raw Stock and Piece Dyeing, etc., for the Trade, also dealers in Wool and Wool Stock; steam and water. (Freight address Millbury.) See advertisement.

**Westminster Depot.** C-8. B. & M. RR.

LEE, WM. M.; Shoddy; 2 machines; sell (W) direct.

**West Rutland.** D-8. B. & M. RR, Cent. Mass. Div.

LAKEVILLE WOOLEN CO; F. B. Stearns, (W) supt, and buyer; Sateenet; 2 sets; 28 looms; steam and water; Bacon & Co, N. Y., s. agts.

**West Stoughton.** F-12. N. Y., N. H. & H. RR.

STOUGHTON MILLS; 170 Summer St., (W) Boston); \$50,000; Morris Feinberg, pres, and gen'l mgr; R. Bro. unfield, treas; John Beaumont, supt; Extracts and Wool Shoddies; water and steam; sell direct; R. Broomfield, buyer.

**West Warren.** F.7. B. & A. RR.

WARREN COTTON MILLS, of the Thorn. (C) dike Co; Chas. H. Fiske, (Boston), pres); P. Olsen, (Boston), treas.; C. H. Hobbs, agt; Geo. A. Moody, supt; Tickings, Cottonades, Shirtings, Cassimeres, Blanket Linings, Denims, Mackintosh Lining, Hushing Cloth; 26,864 ring and 4,620 mule spindles; 200 looms; water and steam; dye; Bliss, Fabyan & Co, N. Y., Boston, Chicago and Phila., s. agts. C. H. Hobbs, buyer. See also *Thorndike.*

**Whately.** D-5. N. Y, N. H. & H. RR.

SANDERSON, LYMAN M; Cotton Cloths (C) Lines and Dish Mops; 2 twisting machines; hand power; buy 8-1 yards bleached for mops; sell direct. Freight address, No. Hatfield.

**White Valley.** See Smithville.**Whitinsville.** F.9. Linwood St. Ry. at Whitins, N. N. N. H. & H. RR, Wor. Div. See also Northbridge.

LINWOOD COTTON MILL; Edward Whitin, (C) treas; A. E. Adams, agt; A. G. Maddox, supt; Shirtings and Sheetings; 13,076 ring and 12,388 mule spindles; 700 looms; water and steam; Whitin & Collins, N. Y, s. agts.

UXBRIDGE COTTON MILLS; \$125,000; Fred'k (C) B. Whitin, agt; Fine Sheetings; 10,900 ring and 5,500 mule spindles; 44 looms; steam and water; Whitin & Collins, N. Y, s. agts; Fred'k B. Whitin, buyer.

WHITINSVILLE COTTON MILLS; Edw. (C) Whitin, treas; A. E. Adams, supt; Shirtings; 14,000 ring spindles; 360 looms; water and steam; Whitin & Collins, N. Y, s. agts.

**Wilkinsonville.** F.9. N. Y, N. H. & H. RR, Wor. Div.

BUTTONWOOD SHODDY MILL; A. M. (W) Prescott, prop; (formerly S. A. Prescott); C. S. White, supt; Shoddy, Custom Work Only; 1 set; steam and water. (P. O. address, Sutton.)

SMITH, FRED S; Shoddy and Flocks (W) and Scouring, 8 flock cutters; 2 pickers; 1 washer; 4 dusters; water and steam.

**Williamsburg.** D-4. N. Y, N. H. & H. RR, Northampton Div.

HAMPSHIRE MILLS; *not running.*

**Williamstown.** B-2. Fitch. RR.

BOSTON FINISHING WORKS; (B I D & F) Chas. Heap, prop; Herbert Heap, agt; Bleachers, Dyers and Finishers, Shirtings, Sheetings, Canton Flannels and Filled Goods, Silecias, Sateens, Corset Jeans Cambries, Sleeve Linings, Pocketings and Flannelettes; steam and water.

WILLIAMSTOWN MFG. CO; \$300,000; A. C. (C) Houghton, pres; Geo. Hopkins, treas; R. R. Kelly, supt; 64x64 Print Cloths and Fancies; 8,688 ring and 10,944 mule spindles; 450 looms; water and steam; sell direct; R. R. Kelly, buyer.

**Winchendon.** B-8. Fitch. RR, Wor. & Ches. Divs. and B. & A. RR.

WHITE, N. D. & SONS; Nelson and Glenal- (C) lan Mills; James Ganey, supt; Denims; 11,600 spindles; 400 looms; water and steam; dye; sell direct.

**Winchester.** D-12. B. & M. RR, So. Div.

BACON, BROS; (successors to Chas. N. (W) Bacon); (98 Milk St., Boston); Feltting, Felt Wheels and Wool Wadding; 10 single sets cards; steam; dye sell direct.

EASTERS FELT & BUFFING WHEEL CO; (W) Thos. J. Donnelly, treas. and buyer; Felt and Felt Polishing Wheels; Wool Wadding; 7 cards; steam; sell direct. (P. O. address, Lock Box 381.)

**Worcester.** E-9. B. & A. B. & M. Fitch, N. Y, N. H. & H. and W. & S. RRs.

AETNA KNITTING CO.; \$75,000; C. S. (K) Holden, pres., and treas.; Men's Woolen Hosiery; 3 sets; 1320 mule spindles; 100 knitting machines; steam and water; dye; sell direct; C. S. Holden, buyer.

BAY STATE WORSTED CO; Geo. Daniels (W) and D. O'Connell; Fancy Worsteds and Cotton Worsteds; 28 looms; steam; L. Bachman, 463 Broome St, N. Y, s. agt.

BROWN, WM. W.; 370 Park Ave.; "Beach" (C) Jackets and Cloth; 12 looms; sell direct; Wm. W. Brown, buyer. (Buy 10/2 to 13/2 yarn.)

CRANSKA THREAD CO; Floyd Cranska, (C) treas; Nathan Howe, mgr; Manufacturers' Threads; steam; sell direct; Nathan Howe, buyer. (Spinning mill at Moosup. Conn.)

CURTIS MFG. CO; \$60,000; Chas. G. Strat- (W) ton, pres., treas., mgr. and supt.; Satinets; 6 sets; 42 broad and 20 narrow looms; steam and water; dye; Nostrand & Moore, and F. R. Masters & Co., N. Y, s. agts.; C. G. Stratton, buyer. (Buy cotton yarn, No. 2 single on warp beams.)

DARLING, A. W.; Satinets; 2 sets; 28 (W) looms; steam and water; Fred'k Victor & Achelis and Wm. Iselin & Co. s. agts. Mill at Cherry Valley.

ELECTRIC WOOLEN MILL; Z. A. Hubley, (W) mgr; Satinets; 2 sets; 24 looms; steam; Bacon & Co, N. Y, s. agts.

GREEN, J. C.; 36 Southgate St.; Dresser (C) of Cotton Warps, 14/1 to 26/1 on Beams; 1 slasher, 6 dressers.

HOPEVILLE MFG. CO; \$30,000; Geo. A. (W) Bigelow, pres. and treas; G. M. Stoddard, supt; Cotton Warp Cheviots and Meltons; 6 sets; 1848 mule spindles; 110 looms; steam; dye; Bacon & Co., s. agts. (Buy yarn.)

JAMESVILLE WOOLEN MILL; P. G. (W) Kent; Woolens; 7 sets; 24 broad and 40 narrow looms; water and steam; dye; Stephens, Sanford & Handy, s. agts.

ORNDORFF, F. C.; Cartridge Belts. (Buy (C) yarn.)

QUEENSBURY MILLS; \$100,000; H. Hodg- (W) son, pres. and treas; Fred Hodgson, supt; Commission Spinning Worsted Yarns in White and Colors; 4000 spindles; (Bradford system); 3 combs; 3 sets; steam; sell direct.

SMITH, F. C.; Satinets; 2 sets; 32 looms; (W) water and steam; dye; Lawrie, Mann & Downe, N. Y., s. agts. (Buy C. warp.)

SOUTHGATE WOOLEN CO. (Inc.); 32 South- (W) gate St.; \$15,000; Geo. W. Davis, pres. and treas.; M. S. Holley, supt.; Cotton Warp Suitings, Skirtings, Shirtings and Satinets; 2 sets; 42 looms; steam; sell direct; Geo. W. Davis, buyer. (Buy 18 blk. cotton warp.)

STONEVILLE WORSTED MILL. See Auburn, Mass.

TATNUCK WOOLEN MILL; F. C. Smith; (W) satinets; 2 sets; 32 looms; water and steam; dye; Lawrie, Mann & Drowne, s. agts.; F. C. Smith, buyer.

THAYER MFG. CO., L. D.; Lagrange (C & S) St.; \$25,000; L. D. Thayer, pres. and treas.; Tapes, Webbing, Ribbons (Cotton and Silk), and Bindings; 144 looms; steam; sell direct; L. D. Thayer, buyer.

THAYER WOOLEN CO.; L. F. Kilty, supt.; (W) Satinets; 3 sets; 40 looms; steam; Bacon & Co. and Flitmann & Co., s. agts. (See No. Oxford.) (Operating Piedmont Mill.)

U. S. STEEL CORP. (successor to Washburn (C) & Moen Branch); Braiders of Insulated Wire and Cables.

WACHUSETT MILLS; 246 Southbridge St.; (C) (Inc. 1894); \$50,000; H. W. Smith, pres. and treas.; Richard Powers, supt.; "Rub Dry" Bath Towels; Nettings; 150 looms; steam; sell direct, Cable Bldg., N. Y.; Harry W. Smith, buyer. (Buy 20/2, 16/3, 12/2, 24/3, 30/2, 30/3 mercerized yarn.)

WACHUSETT THREAD CO., 116 Gold St; (C) \$50,000; Peter Wood, pres. and treas; James Montgomery, sec. and mgr; Chas. Dolan, supt; Spool Thread; do not spin; steam; dye; sell direct; James Montgomery buyer. (Buy 16 to 908 to 2, 3 and 4 ply carded, combed and Sea Island.)

WILLIAMS, THOMAS, 212 June St; Satin- (W) ets; 2 sets; 32 looms; steam; F. Victor & Achelis, N. Y, s. agts.

**WHITTALL, M. J.**; Wilton, Plush and (W) Brussels Carpets; 177 looms; steam; dye, sell direct; 801 Hartford Bldg, 41 Union Sq., N. Y. (Buy carpet worsteds, 12s to 16s.)

**WHITTALL & THOMAS**; Edgeworth Mill; (W) Worsted Yarns; 11 combs; 8 sets; 5,600 spindles; steam; sell direct; Alfred Thomas, buyer.

**WITTER, H. M. & Co.**; Tapes, Bindings, (C) Webs, Bed Laces; 70 looms; steam; sell direct. (Buy yarns.)

#### THE PETER WOOD DYEING CO.

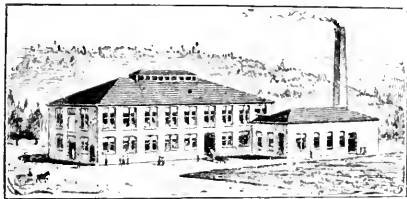

**WOOD DYEING CO, THE PETER**; (B&D) \$20,000; Peter Wood, pres. and treas.; Cotton and Linen Yarn Dyeing, Fast Colors; Also Bleaching; steam.

[Dyers and bleachers of cotton skein yarn, cotton warps, threads, tapes and braids. First-class work. Prompt service. Up-to-date equipment. Works on Holmes St.]

**WORCESTER BLEACH & DYE WORKS (B&D) Co.**; Jas. E. Orr, treas.; Bleachers and Dyers of Cotton and Glazed Cotton Yarns and Warps, Braids, Threads, Tapes, etc.; steam.

**WORCESTER CARPET MILL**; M. J. Whittall, (W) prop.; Carpets, Rugs and Worsted Yarn; 6 sets; 6 combs; 54 looms; water and steam; dye; sell direct. (Buy cotton and jute yarns.)

**WORCESTER DUSTING MILL**; N. Pen- (W) stein, prop; 810 Beach St; Cleaning and Dusting all kinds of Wool Waste, Shoddy and Extracts; Also Burr Picking; 5 dusters; 3 cards; 1 garnett; electric; sell direct; N. Penstein, buyer. (Buy mixed yarns (hard ends) from mills and dealers.)

**WORCESTER TEXTILE Co.** Removed to Franklin, Mass.

**WORCESTER THREAD CO**; 51 Hermon St; (F) E. D. Thayer, Jr, pres; W. B. Scofield, treas; Linen Threads for Shoe Manufacturers and Linen Yarns; 1,000 spindles; steam; dye; sell direct and Locke Bros, 134 Lincoln St, Boston, s. agts.

**WORCESTER WOOLEN MILL CO, THE**; (W) (P. O. Box 1113); \$30,000; Edw. D. Thayer, Jr, pres. and treas; John Legg, supt; Finest Cassimeres and Worsteds; 13 sets; 68 looms; steam; dye; Stevens, Sanford & Handy, James Talcott and J. T. Hams Co., N. Y., s. agts; Frank S. Fay, buyer. (Buy yarns.)

**Wrentham**, G-II, N. Y., N. H. & H., R R Prov. Div.

**BEAUMONT, BENJAMIN**; Fine Wool (W) Shoddies and Extracts; Custom Carding and Picking; water.

**FARNUM, MOSES T**; Glenwood Mills; (W) Shoddy; 6 cards; 3 pickers; water and steam; dye.

## MICHIGAN.

See map on page 136.

For explanations of abbreviations see page 66.

**Acme**, D-9, C & W. M. RR.

**HOXSIE & SCRIPTURE**; East Bay Woolen (W) Mills; J. A. Scripture, supt.; John Hoxsie, buyer; Kerseys, Flannels, Blankets, Yarns; 1 set; 7 looms; steam and water; dye; sell direct. (RR. station, Traverse City.)

**Adrian**, H-II, L. S. & M. S. RR, D. & L. N. RR.

**ADRIAN KNITTING CO., THE**; \$51,000; (K) (\$34,000 paid in); Ladd J. Lewis, pres. and mgr.; B. E. Graves, vice-pres.; Geo. H. Lewis, sec. and treas.; Ribbed Knit Underwear; 15 knitting machines; steam; sell direct; Ladd J. Lewis, buyer.

**Alma**, F-10, Ann A. RR; D. G. R. & W. RR.

**ALMA WOOLEN MILL**; H. W. Moore, (W) prop.; Woolen Goods, Yarn, Blankets, Flannels, etc.; 1 set; 1 comb; 4 looms; steam; dye; sell direct.

**Alpena**, C-II, A. & N. RR; D. B. C. & A. RR.

**ALPENA WOOLEN MILL Co.**; \$7500; (W) A. N. Estes, pres; L. V. Skillings, treas., supt. and buyer; Yarns, Cassimeres, Flannels and Blankets; 2 sets; 2 looms; steam; dye; sell direct.

**Ann Arbor**, G-II, M. C. RR; T. A. H. & N. M. RR.

**Bock, E. C**; Sweaters, Cardigan Jack (K) ets, Mitts, Skirts, etc.; 3 knitting machines; 2 sewing machines; sell direct. (Buys yarn.)

**HAY & TODD MFG. Co.**, of Ypsilanti; J. (K) B. Colvan, pres; W. L. Pack, treas; Jos. Soper, vice pres; Full Fashioned and Cut Underwear; 50 knitting machines; steam; sell direct. Branch of the Ypsilanti mill.

**Bay City**, E-19, D. & M. RR; F. & P. M. RR; M. C. RR.

**BAY CITY KNITTING Co**; \$25,000; Henry (K) B. Smith, pres; D. L. Galbraith, treas; A. Galbraith, supt.; Hosiery of all kinds; 35 knitting machines; steam and electric; dye; sell direct; D. L. Galbraith, buyer. (Buy worsteds in 16s, 18s, 20s, 22s and 28s; cotton in 10s, 16s, 12s, 20s, 28s, 34s; mercerized in 8s, 12s, 20s, 26s, 32s, 50s, 70s.) (Expect to move into new mill with 100 machines, about July 1st.)

**Belding**, (Ionia County), F-9, Detroit, Pere M. RR.

**BELDING BROS. & Co.**; \$1,000,000; M. M. (S) Belding, pres; M. M. Belding, Jr, treas; F. W. Howard, supt. and buyer; Silk Thread, Filo Floss, Etchings & Wash Silks, Serges, Satins, Gros Grains, Hosiery, Etc.; 15,000 spindles; 250 looms; steam; dye; sell direct and Geo. W. Ellis & Co., Phila.; W. S. Belding & Co., Bal o.; C. E. Adams & Co., Boston; Coyle & Sargent, St. Louis and C. P. Howes & Co., St. Paul, s. agts.; F. W. Howard, buyer for the Belding mill. (Building a new mill 50 x 400, four st. ries and annex, partly completed March 02. (Also Northhampton, Mass., and Rockville Ct.)

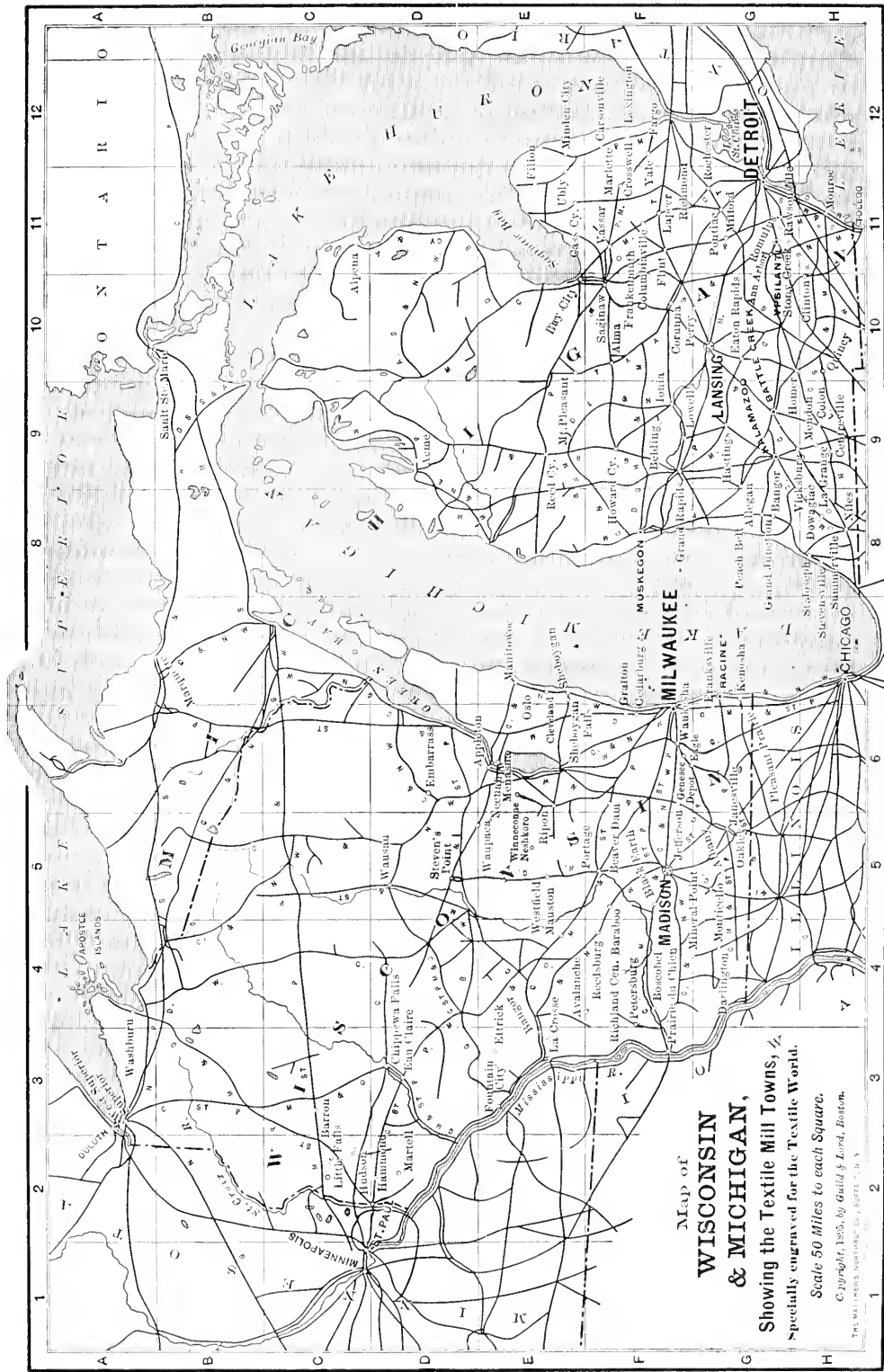

**Map of**  
**WISCONSIN**  
**& MICHIGAN,**  
**Showing the Textile Mill Towns, 1/2**  
**Scale 50 Miles to each Square.**

Copyright, 1905, by **David & Lucie, Boston.**  
 THE WALLACE MAPUBLISHING CO., BOSTON, U. S. A.



**RICHARDSON SILK CO.**; \$200,000; Geo. P. (S) Richardson, pres. and treas.; Silk and Mohair Braids, Sewing and Embroidery Silk, Machine Twist, Etc.; 2500 spindles; 120 braiders; steam and water; dye; N. Y. office, 546 Broadway.

**Centreville.** H-9. M. C. RR.

**MICHIGAN CENTRAL WOOLEN CO.**; \$50. (K) 000; Hugh P. Stuart, pres.; Frank S. Cummings, treas.; Hygienic Sleeping Garments and Men's Underwear; 4 sets; 1020 cotton spindles; 14 knitting machines; 5 ribbing machines; steam and water; E. M. Townsend & Co., s. agts. for Sleeping Garments; underwear direct; Frank S. Cummings, buyer.

**Cheboygan.** C-10. Mich. Cen. RR.

**CHEBOYGAN CARPET & RUG WORKS**; (W) A. B. Ellis, prop; Rugs made from old carpets, also make Rag Carpets; 5 looms; electricity.

**Clare.** E-10. Ann Arbor, F. & P. M. RR.

**WOLSEY**, W.; Men's Heavy Wool (K) Socks and Hand Knit Wool Mittens; 15 knitting machines; steam; sell direct.

**Clinton.** H-10. L. S. & M. S. RR.

**CLINTON KNITTING CO**; \$25,000; Edwin (K) R. Smith, pres.; W. A. Kimball, treas.; H. H. Humphrey, supt.; Wool and Worsted Gloves, Mittens and Hosiery; 95 knitting machines; 9 sewing machines; dye and finish; Mayer Bros. & Co., N. Y., s. agts.

**CLINTON WOOLEN MFG. CO.**; \$100,000; (W) W. P. Hamilton, pres.; Jas. Hamilton, treas.; W. S. Kimball, sec.; A. C. Huntington, supt.; W. S. Kimball, buyer; Men's Wear; 9 sets; 44 looms; steam; dye; E. G. Hamford, N. Y., and O. L. Jones, Chicago, s. agts.

**Colon.** H-9. M. C. RR.

**LAMB KNIT GOODS CO.**; \$45,975; Chas. (K) Clement, pres.; Edwin R. Hill, treas.; Thos. J. Hill, supt. and buyer; Gloves, Mittens, Specialties in Silks and Australias; 125 knitting machines; steam; dye; sell direct.

**Columbiaville.** F-11. M. C. RR.

**COLUMBIAVILLE WOOLEN MILLS**; Estate (W) of William Peter; Jacob Auel, supt.; Meltons, Cassimeres and Dress Goods; 7 sets; 35 looms; steam; dye; Curtiss & Warren, Chicago and N. Y., s. agts.

**Deckerville.** F-12. (Not shown on map), P. M. RR.

**DECKERVILLE WOOLEN MILL**; A. Jones (W) (Ugly, Mich.), pres. (Purchased Minden City Woolen Mill.) *Will not start this year.*

**Detroit.** G-11.

**ANGORA KNITTING CO.**, The; 656-660 St. (K) Aubin Ave; \$12,500; (successor to the Crown Knitting Mills); Carl Rinke, pres. and supt.; George Rinke, sec. and treas.; Cotton, Wool and Worsted, Ladies' and Children's Plain and Ribbed Hose, also Half Hose in cotton, wool and worsted; 20 knitting machines; dye.

**CHICAGO HOSIERY CO**; German and (K) Lumbermen's Socks, Bicycle Hose; 35 knitting machines; steam. (Formerly Chicago, Ill.)

**DETROIT-ALASKA KNITTING MILLS**; (K) \$25,000; I. Frank, pres.; E. Frank, treas.; Edward Murby, supt.; Alaska Socks; 140 knitting machines; steam and electric; sell direct. I. Frank, buyer.

**DETROIT COTTON BATTING MILLS**; 171-175 (C) East Atwater St; I. I. Peritz, pres.; W. Y. Peritz, treas.; C. N. Mullican, supt.; Cotton Bating, etc; 19 cards; gas; sell direct; C. N. Mullican, buyer.

**HAY & TODD MFG. CO.** (Branch mill); (K) Cor. Chaplain and Baudin Sts; Full Fashioned Underwear; 80 knitting machines; 15 sewing machines; steam. (Also Ann Arbor and Ypsilanti.)

**NOVELTY KNITTING CO**; cor. 4th & Pot- (K) ter Sts; \$12,000; E. J. Snover, pres.; H. H. Humphrey, treas. supt. and buyer; Gloves, Scotch Mittens, and Wool Half Hose; 103 knitting machines; steam; dye; buy yarn; sell direct.

**PIONEER BUFFALO COAT MFG. CO.**; 74, 76 (K) 75 Fort St. East; Wm. M. Finck, pres.; Conrad Speck, Jr., treas.; L. Abramson, supt. and buyer; Russian Buffalo and Astrakan Coats, etc.; steam; dye; sell direct. (Purchased Defiance Woolen Mills, Defiance, Ohio, which sec.)

**PROGRESSIVE KNITTING MILLS**; J. Fried- (K) man and Jos. Rosenfeld; 40-46 Champlain St; Ladies', Misses', Infants', Men's and Boys' Mittens, Gloves and Hosiery; 250 knitting machines; steam; sell direct. (Buy 2/10, 2/20, 2/25, 3/36, 3/30 and 2/40 worsted and 1/9, 1/10, 2/11 cotton yarn.)

**RUMSEY WOOL STOCK CO.**; See Roch- (W) ester.

**RYAN BROS. KNITTING CO.**; \$30,000; John (K) T. Ryan, pres.; Denis T. Ryan, treas.; D. T. and J. T. Ryan, supts. and buyers; Cotton and Woolen Hosiery, Gloves, Mitts, Jackets, Sweaters, Lumbermen and Miners' Goods; 125 knitting machines; electricity; finish; sell direct.

**SPECIAL KNITTING WORKS**; Chas. L. (K) Richardot, 601 Sixth St; Golf Goods, etc; 10 knitting machines.

**WESTERN KNITTING MILLS.** See Rochester.

**WESTERN ROBE CO.**; Orleans and Boule- (K) vard Sts.; (partnership); Jno. A. Chapman, supt.; Robes, Coats and Men's, Women's and Children's Knitted Fabrics; 16 knitting machines; steam; dye; sell direct; Hugh Wallace, buyer.

**Eaton Rapids.** G-10. L. S. & M. S. RR.; M. C. RR.

**EATON RAPIDS WOOLEN MILLS**; Horner (W) Bros; Wool and Merino Knitting and Weaving Yarns; 3 sets; steam and water; dye; sell direct; firm, buyers.

**Flint.** F-11. C. & G. T. RR.; F. & P. M. RR.

**FLINT WOOLEN MILLS CO**; J. E. (W) Shortle, supt.; Fancy Cassimeres; 6 sets; 28 broad looms; steam; dye; sell direct.

**Frankenmuth.** F-11. F. & P. M. RR.

**RANKE, FRANZ**; Yarns, Mitts and (W&K) Socks; 1 set; 4 knitting machines; steam dye; sell direct. (RR. station at Gera.)

**Grand Rapids.** F-9. P. M. RR.; M. C. RR.; D. G. H. & M. RR.; G. R. & I. RR.; L. S. & M. S. RR.

**GLOBE KNITTING WORKS**; Commerce & (K) Goodrich Sts.; \$50,000; E. A. Clements, pres.; H. M. Liesveld, treas.; C. A. Clements, supt.; Men's, Women's and Children's Jersey Ribbed Underwear; 30 knitting machines; electric power; sell direct and Geo. Cramer & Bro., s. agts. (Buy principal varieties of cotton and worsted yarn.)

**GRAND RAPIDS FELT BOOT CO**; (W & K) \$100,000; E. G. Studley, pres. and treas.; J.

- Stewart, supt.; Knit and Felt Boots; also Rubber Boots and Shoes; 14 sets; 250 spindles; 12 knitting machines; steam; dye; J. E. Coulter, s. agt; E. G. Studley, buyer.
- GRAND RAPIDS KNITTING CO.** (author-**(K)** ized); \$50,000; E. B. Fisher, pres.; Full Fashioned Ribbed Underwear; 25 knitting machines; electric power; Geo. S. Cramer & Bro., N. Y., s. agts. (Buy 1/25, 1/50 worsted, 1/20, 1/40, 50/2 cotton and 2/20, 2/60, 2/80 mercerized yarn.)
- IMPERIAL KNITTING MILLS.** See Ionia.
- SIMMONS KNITTING CO.**; 4 and 6 Pearl (**K** St); \$50,000; J. W. Simmons, pres.; J. C. Bonnell, treas.; W. P. Drumheller, supt.; Ladies', Misses' and Children's Underwear and Men's Union Suits; 14 knitting machines; sell direct; treas., buyer.
- STAR KNITTING WORKS**; \$60,000; Sam'l (**K** S. Walker, pres.; G. T. Kendal, treas.; Women's, Misses' and Children's Ribbed Underwear; 60 knitting machines; steam; sell direct; Sam'l S. Walker buyer.
- Hastings.** G-9. C. K. & S. RR.; M. C. RR.
- HASTINGS WOOL BOOT CO.**; \$120,000; (**W**) Chester Messer, pres.; M. L. Cook, sec., treas. and mgr.; Jos. Burnett, supt.; Wool or Felt Boots; 16 cards; steam; dye; R. B. Messer, s. agt; M. L. Cook, buyer.
- Howard City.** F-9. D. L. & N. RR.; G. R. & I. RR.
- MESSENGER, A. W.**; Woolens. Rebuilt (**W**) burned plant.
- Ionia.** F-9. P. M. RR.; D. G. H. & M. RR.
- IMPERIAL KNITTING CO.**; \$25,000; E. E. (**K**) Dennis, pres.; N. J. G. Van Keulen, sec., treas. and buyer; H. E. Cook, supt.; Cotton and Wool Hosiery; 100 knitting machines; steam; sell direct. (Prison Labor.) Office and P. O. address at Grand Rapids.
- Lansing.** G-10. L. S. & M. S. RR.; M. C. RR.; C. & G. T. RR.; D. L. & N. RR.
- MICHIGAN KNITTING CO.**; \$25,000; F. (**K**) Thoman, pres.; J. Himmelberger, treas.; J. P. St. John, supt.; Silk, Wool and Worsted Mittens and Gloves, Full Fashioned Knit Underwear, Toques and Sweaters; 125 knitting machines; steam; dye; sell direct; J. Himmelberger, buyer.
- Lexington.** F-12. F. & P. M. RR.
- LEXINGTON WOOLEN MILLS**; John (**W** & **K** L. Fead & Sons; \$25,000; John L. Fead, pres.; Fred F. Fead, treas.; John W. Fead, agt.; Wm. L. Fead, supt.; Lumbermen's Home-made Mittens and Socks, Yarns, Flannels, Cloths, and Blankets; 1 set; 7 looms; 420 woolen spindles; 30 knitting machines; steam; dye; sell direct; Chas. Fead, buyer. (RR. station, Croswell, five miles west.)
- Marlette.** F-11. F. & P. M. RR.
- DORMAN & SON**; D. H. Dorman, supt. (**W**) and buyer; Tweeds, Flannels, Cloths, Bed Blankets, Horse Blankets and Yarns; 1 set; 4 looms; 200 spindles; steam; dye; sell direct.
- Middleville.** G-S. Mich. Cen. RR.
- WARREN FEATHERBONE CO.** (Three **C** & **S** Oaks); E. K. Warren, pres.; Cotton Weaving and Silk Ribbons; 40 looms; steam and water; dye.
- Milford.** G-11. F. & P. M. RR.
- TRUMP, F. H., & SON**; Hosiery; 15 knit-**(K)** ting machines; hand power; sell direct. *Not running.*
- Monroe.** H-11. F. & P. M. RR.; L. S. & M. S. RR.; M. C. RR.
- BOEHME & RAUCH CORDAGE CO.**; Braided (**J**) Cord, Cattle Ties, Huffers; 75 braiding machines; steam; sell direct.
- PLEWES, JOHN**; Yarns, Batts, Rolls; (**W** & **K**) Woolen Socks, Cassimeres; 2 sets; 3 looms; 2 knitting machines; water; dye.
- Mt. Pleasant.** E-10. F. & P. M. RR.; A. A. RR.
- AMBLEE, JOSEPH**; Woolens; 1 set; 4 (**W**) looms.
- Muskegon.** F-S. C. & W. M. RR.; G. R. & Ind. RR.; T. S. & M. RR.
- AMAZON KNITTING CO.**; \$200,000; C. H. (**K**) Hackley, pres.; Thos. Hume, treas.; G. W. Powell, vice-pres. and agt; M. H. Powell, and A. P. Griffith, supts; Hosiery, Gloves, Mittens and Underwear; 5 sets; 425 knitting machines; 240 sewing machines; steam; dye; sell direct; superintendents, buyers.
- HAIGHT, LOUIS P.**; Muskegon Knitting (**K**) Mills; Frank Congdon, supt.; Haight's Vegetable Silk Hose and General Line of High Grade Adult's and Infant's Underwear; 26 knitting machines; steam; dye; A. S. Haight & Co., 49 Leonard St, N. Y., s. agts.; Louis P. Haight, buyer. (Buy Australian wool, Sea Island, Mercerized and Combed Peeler yarn.)
- Owosso.** F-10. Ann Arbor, G. T. & Mich. Cent. RRs.
- BURNETT KNITTING CO., THE**; \$9,000; (**K**) I. H. Keeler, pres.; Chas. E. Burnett, treas. and supt.; Gloves, Mittens and Hosiery; steam; sell direct; Chas. E. Burnett, buyer. (Buy 4s to 14s white, 4s to 10s mixes and 12s to 40s fast black colors.)
- OWOSSO KNITTING MILLS.** *Out of business.*
- Perry.** G-10. C. & G. T. RR.
- PERRY GLOVE AND MITTEN CO.**; Perry (**K**) Knitting Mill; \$30,000; I. W. Lamb, pres. and supt.; C. H. Calkins, treas.; Gloves Mittens and Leggings; 48 knitting machines; 5 sewing machines; steam; dye; sell direct; buy 3/14s, 3/15s, 3/17s, 3/18s and 3/24s worsted yarns.
- Petoskey.** C-9. G. R. & I. RR.; C. & W. M. RR.
- WITTE, ALBERT & SON**; Hose and Half (**K**) Hose; 6 knitting machines; sell direct. Buy 2/16, 2/20 woolen, 2/13 1/9 merino and 2/16 worsted yarns.
- Pontiac.** G-H. D. G. H. & M. Dvs. of G. T. & P. O. & N. RR.
- PONTIAC KNIT BOOT CO.** (Absorbed by (**K**) the Grand Rapids Felt Boot Co.) See *Grand Rapids.*
- PONTIAC KNITTING WORKS CO.**; \$100,000; (**K**) C. E. Wakeman, pres; Porter A. Hitchcock, treas.; Underwear, Hosiery, Gloves, Jackets, Mittens, Filled Goods; 3 sets; 150 knitting machines; 7 sewing machines; steam and water; dye; sell direct.
- Quincy.** H-10. L. S. & M. S. RR.
- QUINCY KNITTING CO.** See *Three Rivers.*
- Reed City.** E-9. F. & P. RR. M. G. R. & I. RR.
- LAMBERG, WM.**; Reed City Woolen Mills; (**W**) 1 set; 1 broad, 2 narrow looms; Domestic; steam; dye.
- Richmond.** F-12. R.R. Detroit Dvs. of G. T. RR.
- RICHMOND WOOLEN MILL**; Walter (**W** & **K**) Davidson; Yarns, Blankets, Socks, and Mitts; 2 sets; 2 looms; 7 knitting machines; steam; dye; sell direct. (Buy some cotton yarns.)
- Rochester.** G-11. M. C. RR.
- RUMSEY WOOL STOCK CO.** (Detroit); (**W**) Shoddy; 3 sets.
- WESTERN KNITTING MILLS**; (consoli-**(K)** dated with Western Knitting Mills at Detroit); \$100,000; (\$76,000 paid in); Wm. C. Yawkey, pres; Wm. C. Chapman treas

- C. S. Chapman, gen'l mgr; W. C. and C. S. Chapman, buyers; Men's and Boys' Woolen Gloves, Mitts, Half Hose and Lumbermen's Socks; 6 sets; 375 knitting machines; 15 sewing machines; steam, water and electricity; dye; sell direct.
- Sault Ste Marie.** B. 10. D. S. S. & A. RR; M. St. P. & S. S. M. RR.
- SOO WOOLEN MILL;** McTavish & Cullis, (**W** props; Ridge and Douglass Sts; A. E. Cullis, supt; Woolen Yarns, Blankets and Flannels; 1 set; 4 looms; custom; electric power; dye.
- St. Joseph.** H. S. V. L. RR.; C. & W. M. RR. COOPER, WELLS & Co.; St. Joseph Spin- (**K** ning and Knitting Works; \$250,000; A. W. Wells, pres.; G. F. Milliken, treas.; A. B. Moffatt, sec; Cotton, Woolen and Merino Hosiery; 350 knitting machines; 50 sewing machines; steam; dye; sell direct.
- Summerville.** H. S. Mich. Cent. RR. (Near-station Pokagon.)
- WILLIS, Z. H.; Blankets, Flannels and (**W** Yarn; 1 set; 1 broad and 1 narrow loom; 1 knitting machine; water; dye and finish.
- Three Rivers.** H. 9. Mich. Cent. RR.; L. S. & M. S. RR.
- QUINCY KNITTING CO; (formerly at [**K** Quincy); \$15,000; W. E. Clark, pres; F. H. Case, treas; Geo. A. Cornell, supt; Gloves, Mittens, Toques, Leggins, etc; 52 knitting machines; steam; dye; sell direct.
- Vassar.** F. H. F. & P. M. RR.; M. C. RR. BALBIAN BROS. *See Tiffin, Ohio.*
- Yale.** F. 12. F. & P. M. RR.
- LIVINGSTON, JAS. & Co; Jas. McColl, (**F** supt. and buyer; Dressed Flax and Tow; Steam; sell direct. (Branches at Brown City, Pigeon, Crosswell, Fargo and Decker-ville).
- YALE WOOLEN MILLS; Chas. Andreae & (**W** Sons; Frank W. Andreae, supt.; Cassimeres; 2 sets; 10 broad looms; steam; dye and finish; Curtiss & Warren, Chicago, s. agts; F. W. Andreae, buyer.
- Ypsilanti.** G. H. M. C. RR.; L. S. & M. S. RR.
- HAY & TODD MFG. Co.; \$150,000; J. B. (**K** Colvay, pres.; W. L. Pack, treas.; John Dorenburg, vice-pres.; Underwear; 163 knitting machines; steam and water; sell direct. (Branch mill at Ann Arbor and Detroit.)

## MINNESOTA.

No map.

For explanation of abbreviations see page 66.

- Austin.** C. G. W. RR; C. M. & St. P.
- AMERICAN FLAX FIBRE Co; Moore & (**F** I Co., props.; Flax Upholstery Tow; sales-room, 142 Pearl Street, N. Y.
- Albert Lea.** B. C. R. & N. RR.; C. M. & St. P. RR.; M. & St. L. RR.
- ALBERT LEA WOOLEN MILLS; *Removed to Lake Mills, Ia., which see.*
- Cambridge.** St. P. & D. RR.
- BJORBLAND, ERICK; Cambridge Woolen (**W** Mills; Yarns; 2 sets; steam; sell direct. (RR. station, Harris.)
- Chatfield.** C. & N. RR.
- CUSSENS, J. M. *Interested in establishing (**W** a woolen mill.*
- Dututh.** C. St. P. M. & O. RR, G. N. RR, N. P. RR; C. M. & St. P. RR.
- NELSON BROS; 21013 West Superior St; (**K** Men's, Ladies', Children's and Boys' Sweaters, Cardigan Jackets, Knit Shirts and Lumbermen's Underwear; 50 knitting machines; 6 sewing machines; gasoline; sell direct. (Buy woolen and merino yarn, 1-20, 4-20, 1-14, 2-17, and worsted, 2-20, 3-20, 4-18, 4-20, 12, 14, 16.)
- Faribault.** C. M. & St. P. RR.; M. & St. L. RR.
- KLEMER, C. H., & SONS; Faribault (**W** Woolen Mill; Blankets and Flannels; (also make Trousers); 2 sets; 9 looms; water; dye and finish; sell direct.
- Fergus Falls.** G. N. R'y.; N. P. RR.
- FERGUS FALLS WOOLEN MILL; (J. H. (**W** Evans, part owner); Fancy Cassimeres, Blankets, Flannel, Yarns, Bating and Rolls; 2 sets; 7 looms; water; dye; sell direct.
- Fosston.** G. N. RR.
- FOSSTON WOOLEN MILL Co; \$50,000; S. S. (**W** Shadsvold, pres; Lewis Lohm, sec. and treas; Woolens; 1 set; 6 looms; water; dye.
- Heron Lake.** C. & N. W. R'y.
- MINNESOTA FIBRE Co; (succeed J. T. (**F** I Smith); \$65,000; J. T. Smith, pres. and gen. mgr; W. P. St. John, treas.; Upholstery and Spinning Tow; steam; sell direct. Mills at Heron Lake and Fulda, Minn.
- Holmes City.** G. W. RR.
- JOHNSON, G. M.; Holmes City Woolen (**W** Mill; Fine and Coarse Woolen Yarn; 264 spindles; 1 set; steam. (RR. station, Alexandria.)
- Jackson.** C. M. & St. P. RR.
- WALLACE, J. I.; Upholstery Tow; steam; (**F** I sell direct. Also at Sherburn, 33 miles east of Jackson.
- La Crescent.** C. M. & St. P. RR.
- WEBSTER, M., & SONS; W. Webster, (**W** agt.; D. A. Webster, supt.; W. Webster, buyer; Flannels, Shirts; 1 set; 12 looms; 6 sewing machines; water; dye; sell direct.
- Litchfield.** G. N. R'y.
- LITCHFIELD WOOLEN MILLS; H. (**W** & **K** Klausner, supt. and buyer; Blankets, Cassimeres, Flannels, Yarns, Custom Carding; 1 set; 2 knitting machines; 4 looms; steam; dye; sell direct; (buy cotton yarns and waps.)
- Mankato.** C. & N. W. R'y.; C. M. & St. P. RR.; M. & St. L. RR.
- MANKATO MILLS; Co; \$125,000 paid up; (**K** \$150,000 authorized); W. L. Hixon, pres.; J. H. Spencer, treas; M. G. Willard, sec. and supt; Men's, Women's and Children's Seamless Hosiery, Cotton, Woolen and Merino; also Men's, Women's and Children's Mittens, Gloves, Leggins, etc; 3 sets; 1248 spindles; 240 knitting machines; steam; dye; sell direct; M. G. and E. C. Willard, buyers. (Buy worsted, cotton, Peeler cones and skeins, Egyptian and mercerized yarn. (Also Wool Scouring.)
- Minneapolis.**
- MINNEAPOLIS EMBROIDERY WORKS; (**S** John Fruch, prop.; 816 Fourth Street South; Swiss Embroideries, Robes, Silks, Flannels, Trimmings, etc.
- MINNEAPOLIS KNITTING WORKS; \$150,000; (**K** W. A. Barnes, pres.; C. E. Ovenshire, treas.; Perry Starkweather, gen. mgr. and buyer; Children's Knit Waists, Ger-

- man Socks, Lumbermen's Socks, Men's Wool Socks and Half Hose; 125 knitting and 30 sewing machines; steam; dye; sell waists direct; O. L. Jones, Chicago, J. Watson Stuart & Co., Pittsburg, Max Mayer & Son, N. Y., s. agts.
- NELSON BROS. KNITTING WORKS;** Christ (K Nelson, prop.; Sweaters, Underwear, Ladies' Skirts and Hosiery; 15 knitting machines; 6 sewing machines; electricity; sell direct; C. Nelson, buyer. (Buy wool 1/20 and 2/20, worsted 2/22, 3/20, 3/14.)
- NORTHWESTERN KNITTING CO.;** 213 Lynn- (K dale Ave.; \$125,000; Clinton Morrison, pres; C. S. Gold, treas.; F. M. Stowell, sec., supt. and buyer; Men's, Women's and Children's Knit Underwear; 50 knitting machines; steam; sell direct. (Buy cotton 7 to 30 and worsted 20 to 40 yarn.)
- NORTH STAR WOOLEN MILL CO.;** \$400. (W 000; Wm. G. Northup, pres; L. B. Morison, treas; Walter Morison, supt. and buyer; Blankets and Flannels; 13 sets; 83 looms; steam and water; dye; sell direct.
- TAYLOR RUG CO.;** 617 Bryant Ave; Rugs (W from Old Carpets, Ingrain, Brussels and Velvets; and Hssocks; 10 looms; steam; H. H. Taylor, buyer.
- New London.** G. N. Ry.
- SWENSON,** HAROLD; 2 sets; steam. (W
- New Ulm.** C. & N. Ry.
- BROWN COUNTY WOOLEN MILLS;** E. (W & K Small, supt.; Heavy Woolen Seamless Hosiery, Flannels, Blankets, Yarns, All Wool Battings; 1 set; 2 looms; 5 knitting machines; water; dye and finish; sell direct; B. Marschner, buyer.
- Northfield.** C. M. & St. P. RR.; M. & St. L. RR.
- NORTHFIELD KNITTING CO.;** J. A. Mas. (K secy, prop.; Men's Underwear, Sweaters, Women's Skirts; 20 knitting machines; 5 sewing machines; gasotene.
- Pillsbury.** N. P. RR.
- GOLDEN FLEECE WOOLEN MILL (W & K CO.;** F. W. Mattock; E. W. Hubbard, mgr; Tweeds, Flannels, Yarn, Hosiery, Etc; 3 sets; 7 broad looms; 3 knitting machines; steam and water; dye. (See Philbrook.)
- Rochester.** C. & N. Ry.; C. G. W. Ry.
- ROCHESTER WOOLEN MFG. CO.;** \$80,000; (W John A. Cole, pres; Wm H. Knapp, treas; H. K. Terry, gen'l mgr. and agt; Fancy Cassimeres and Cheviots; also make
- Trousers; 3 sets; 14 looms; 35 sewing machines; steam; dye; sell direct. (Buy worsted yarn 1/16, 2/32, etc.)
- Rockford.** M. St. P. & S. S. M. RR.
- BENNER,** F. J.; Rockford Woolen Mill; (W \$20,000; Flannel, Jeans, Yarn, Blankets and Cassimeres; 2 sets; 9 looms; water; dye; sell direct.
- Rushford.** C. M. & St. P. RR.
- RUSHFORD KNITTING MILLS;** \$10,000; (K D. J. Tew, pres; L. Tagliand, treas; W. K. Putnam, supt. and buyer; German Socks and Wool Hosiery; 30 knitting machines; steam; dye; sell direct.
- WEBSTER, JONATHAN, & CO.;** W. Webster, (W agt, supt. and buyer; Hosiery Yarns; 1 set; water; dye.
- St. Paul.**
- RICE,** E.; 55 Davidson Block; Elastic (K Stockings, Knee Caps, Belts and all kinds of Surgical Hosiery; electric motor; sell to wholesale houses; E. Rice, buyer. (Buy combed Sea Island, Egyptian and silk yarn.)
- St Paul Park.** C. B. & N. RR.; C. M. & St. P. RR.
- UNION MILLS CO.;** \$200,000; M. D. Miller, (F1 agt. and buyer; Crash Towels; 480 spindles; 20 looms; steam. *Not running.*
- St. Peter.** C. & N. W. Ry.
- BORNEMANN, B. & SON;** Blan- (K & W kets, Flannels, Yarn, Hosiery; 1 set; 2 looms; 4 knitting machines; steam; dye; sell direct.
- Shakopee.** (RR. name Shakopee Junction.) C. M. & St. P. RR.; M. & O. RR.; M. & St. L. RR.
- NACHTSHEIM, JOHN & MRS. C. M.** *Out of business.*
- Spring Valley.** C. M. & St. P. RR.; W. & W. RR.
- SPRING VALLEY FLAX FIBRE CO.;** \$5200; (F1 John Leuthold, pres; B. F. Farmer, treas; G. M. Warren, sec. and mgr; Upholsters' Flax Tow; steam.
- Stillwater.** C. & N. W. RR.; C. M. & St. P. RR.; St. P. & D. RR.; W. C. RR.
- STATE PRISON;** Twine. (F1
- Taylor's Falls.** N. P. RR.
- TAYLOR'S FALLS WOOLEN MILLS;** Geo. (W W. Dolney; Wool Mattresses, Batting and Rolls; 1 set cards; water; sell direct.

## MISSISSIPPI.

See map on page 68.

For explanation of abbreviations see page 66.

- Aberdeen.** E. A. Hl. Cen.; K. C., M. & B. RR.; M. & O. RR.
- REYNOLDS,** H. E. (and others interested) (C in organizing company to build cotton mill).
- Columbus.** E. S. M. & O. RR.; S. Ry. Co.
- COLUMBUS HOSEY MILLS;** \$30,000; J. (K B. Bell, pres.; V. D. Malloy, sec. and treas.; Ladies' Hosiery, at present; 30 knitting machines; steam, dye.
- TOMBIGBEE MILL;** Shirting, Sheeting, (C Drills, Osaburgs, Rope and Cotton Bagging; 8664 spindles; 252 looms; steam; sell direct.
- Corinth.** C. A. M. & O. RR.; W. S. of S. Ry. Co.
- ALCORN WOOLEN MFG. CO.;** \$50,000; John (W H. Jones, pres.; P. T. Jones, treas.; All Wool Jeans, Cassimeres; 2 sets; 24 looms; 200 sewing machines; dye and finish; sell direct.
- Enterprise.** G. A. M. & O. RR.; Q. & C. RR.
- ENTERPRISE KNITTING MILL;** \$40,000; (K M. W. Buckley, pres; W. G. Buckley, treas; Seamless and Half Hose; 27 knitting machines; 5 sewing machines; steam; dye; sell direct; M. M. Buckley, buyer.
- WANITA MILLS CO.;** \$15,000; C. A. (W Lyerly, pres; F. H. Shults, treas; Woolen Yarns, Batts and Wool Rolls; 1 set; 2 looms; water; dye.
- Hashuqua.** F-4.
- HASHUQUA MFG. CO.;** W. J. & J. H. Hub. (C bard, lessees; Cotton Yarn, Warp, Knitting Cotton, etc.; 1200 ring spindles; water. *Not running since July, 1901.*
- Kosciusko.** F-3. Hl. Cent. RR.
- KOSCIUSKO COTTON MILLS;** \$150,000; C. (C L. Anderson, pres; Walter Burgess, treas; J. S. Pleasants, supt; 39" 4/10 Brown Sheetings; 5000 ring spindles; 160 looms; steam;

- Catlin & Co., N. Y., s. agts. W. Burgess, buyer. (Will install 5,000 more spindles later.)
- Laurel.** H-4. L. & N. RR; N. O. & N. RR.
- LAUREL COTTON MILLS;** \$250,000; Geo. (C) S. Gardiner, pres.; T. J. Woodward, Jr., treas.; J. L. May, supt.; 3 to 5 yard Brown Sheetings; 10,000 spindles; 350 looms; steam; sell direct; T. J. Woodward, Jr., buyer.
- MISSISSIPPI KNITTING MILLS;** J. L. (K) Hughes, Meridian) sec.; Seamless Hosiery and Half Hose; 25 knitting machines.
- Lexington.** F-3. Y. & M. V. RR.
- LEXINGTON COTTON MILLS;** \$100,000; (C) Hon. G. A. Wilson, pres.; M. M. Rayner, vice-pres.; J. E. Stanfield, sec. and treas.; 5,000 spindles. *Proposed.* (Expect to build this fall.)
- McComb City.** H-2. Ill. Cent. RR.
- MCCOMB CITY COTTON MILLS;** \$150,000; (C) J. J. White, pres.; J. J. White, Jr., sec. and treas.; Sheetings, 64x64, 38½ in. wide; 5,000 ring spindles; 180 looms; steam; Woodward, Baldwin Co., s. agts.; J. J. White, Jr., buyer.
- Meridian.** G-4. W. S. of S. Ry. Co.; M. & O. RR.; Q. & C. RR.
- MERIDIAN COTTON MILLS;** \$200,000; L. (C) Rothenberg, pres.; C. W. Robinson, treas.; Louis Cohn, gen. mgr. and buyer; J. H. Ledyard, asst. gen. mgr.; Outing Flannels, Chevots, Fancy Shirtings, Coverts, Plain and Fancy Specialties; 812 spindles; 400 looms; steam; dye; sell direct.
- MERIDIAN MATTRESS FACTORY;** Mat- (C) tresses, Pillows, Pads, Comforts, etc.
- Moorhead.** E-2. So. Ry.; Yazoo Delta RR.
- MOORHEAD COTTON MILLS;** \$150,000; C. H. (C) Pond, pres.; W. Robertshaw, sec. and treas.; Osanburg and Flat Duck; 5,000 ring spindles; 160 looms; steam; J. Spencer Turner Co., N. Y., s. agts.
- Natchez.** H-1. N. O. & N. RR.; Y. & M. V. RR.
- CARPENTER, N. L. & SON;** Batting; 10 (C) cards; steam. *Not running; mill for sale.*
- NATCHEZ COTTON MILLS Co.;** \$225,000; R. (C) F. Learned, pres.; G. W. Koontz, treas.; David M. Dix, sec.; W. H. Lynch, supt.; Brown Shirting, Sheetting, Batting and Drills; 22,500 ring spindles; 576 looms; steam; Treat & Converse, N. Y., Robert McK. Jones & Co., St. Louis, s. agts.; Mr. Dix, buyer.
- Shuqualak.** F-4. See Hashuqua.
- Starkville.** E-4. Ill. Cen.; M. & O. RR.
- STONE COTTON MILLS, JOHN M.;** \$125,000; (C) W. W. Scates, pres.; W. W. Scates, Jr., sec. and treas. *Proposed.*
- TEXTILE NOVELTY Co.;** \$10,000; S. Kolhorn (C) and others; Lenos, Bedford Cords, etc.; 24 looms; steam. *Proposed.*
- Stonewall.** G-4. M. & O. RR.
- STONEWALL COTTON MILLS;** \$400,000; O. F. (C) Cawthon (Mobile), pres.; O. F. Cawthon, Jr., treas.; T. L. Wainwright, sec. supt., agt. and gen. mgr.; Brown Sheetings, Shirtings, Drills, Osanburgs and Yarns; 21,000 spindles; 500 looms; steam; dye; sell direct; T. L. Wainwright, buyer.
- Tupelo.** D-4. K. C. M. & B. RR.
- TUPELO COTTON MILL;** \$125,000; L. D. (C) Hinds, pres.; J. R. Dabbs, sec. and treas.; C. F. Faulkner, supt.; Heavy Sheetting, Drilling and Shirtings; 5,000 ring spindles; 170 looms; steam; sell direct; L. D. Hines, buyer.
- Water Valley.** D-3. I. C. RR.
- YOCONA MILLS;** \$80,000; B. W. Rom- (C) berger, pres.; D. R. Wagner, treas.; C. E. Romberger, supt.; D. R. Wagner, buyer; Twine, Cord, Warp and Yarn; 5000 spindles; steam; dye; sell direct.
- Wesson.** H-2. I. C. RR.
- MISSISSIPPI MILLS;** \$344,000; R. L. (C & W) Saunders, pres.; J. S. Rea, sec. and treas.; T. H. Wilkinson, supt. and buyer; Checks, Cottonades, Domets, Flannel-ettes, Etc, Cassimeres, Chevots, Jeans, Etc.; 16,496 ring spindles; 21 sets; 62 dead and 158 narrow looms; 614 cotton looms; steam; dye; Faulkner, Page & Co., N. Y., s. agts.
- West Point.** E-4. Ill. Cent. RR. M. & O. RR. Sou. Ry.
- WEST POINT COTTON MILLS;** \$110,200; J. (C) A. McArthur, pres. and treas.; F. T. Radford, supt.; 40-2 Ply Yarns, 5,152 ring spindles; steam; sell through agents; F. T. Radford, buyer.
- Winona.** E-3. Ill. Cent. & S. RR.
- WINONA COTTON MILLS;** \$150,000; J. H. (C) Fraiser, pres.; A. H. Milstead, sec. and gen'l mgr.; Henry Hart, treas.; Sheetings; 5000 ring spindles; 170 looms; steam; Catlin & Co., N. Y., s. agts.; A. H. Milstead, buyer.
- Yazoo City.** F-2. Y. & M. V. RR.
- YAZOO COTTON MILLS;** I. H. Barnwell, (C) pres. and treas.; F. C. Haskell, mgr.; Yarns, 40s, single and 2 ply; 5,120 spinning and 2880 twisting spindles; steam; sell direct; F. C. Haskell, buyer.

## MISSOURI.

No map.

For explanation of abbreviations see page 66.

- Boonville.** M. K. & T. & M. P. RR.
- MISSOURI REFORM SCHOOL FOR BOYS.** *Discontinued making hose.*
- California.** M. P. RR.
- CALIFORNIA WOOLEN MILL Co.;** \$15,000; (W) F. Hempel, pres.; F. E. Eberhardt, treas.; Peter Herfurth, agt. and buyer; F. Hugelmann, mgr.; Skirts, Flannels, Blankets, Cassimeres and Yarns; 1 set; 4 broad and 4 narrow looms; 1 knitting machine; steam; dye; L. C. Wanamaker, 14 Thomas St., N. Y., s. agts.
- Carrollton.** A. T. & St. F. RR.; C. B. & Q. RR.
- MCINTYRE, WILLIAM, Mrs.;** Carrollton (W) Woollen Mills; Hosiery Yarn; 1 set; steam; dye.
- Carthage.** M. P. RR. & St. Louis and San Francisco RR.
- CARTHAGE WOOLEN MILL Co.;** \$70,000; (W) Frank Hill, pres.; James F. Hill, treas.; Jeans and Worsteds; 3 sets; 104 looms; steam; dye. *Shut down; probably permanently.* (Plant will be sold.)
- Denver.** (12 miles from Albany.) C. B. & Q. RR.; St. J. Br.
- DENVER WOOLEN MILLS;** Smith, (W) Cowles & Smith; B. Smith, pres.; A. Z. Cowles, treas.; P. M. Smith, supt.; Yarns and Blankets; 1 set; 3 looms; steam; dye; sell direct; B. Smith, buyer.
- Humansville.** K. C. & S. RR.
- HAGGI, S., & SONS;** Blankets, Flannels, (W) Jeans, Linseys and Stocking Yarns; 2 sets; 12 looms; steam; dye.

**Mercer.** C. R. I. & P. RR.

MERCER MILLS; H. J. Alley, Jr, admr; (**W**) Yarn, Flannels, Jeans, Blankets and Linseys; 1 set; 4 looms; steam; dye.

**Neosho.** A. T. & S. F. RR.; K. C. P. & G. RR. HAINSWORTH, T; Blankets, Flannels, Yarns, Woolen and Cotton Hosiery and Half Hose; 1 set; 3 looms; 8 knitting machines; steam; dye; sell direct; (Buy cotton yarn, 2/5 to 1/10.)

**Paris.** M. K. & T. RR.

PARIS WOOLEN MILL; W. H. Blackford; (**W**) Jeans, Cassimeres, Flannels, Robes, Blankets, Satinets, Yarns, Etc; 1 set; 400 spindles; steam; dye and finish; sell direct.

**Pay Down.** A. T. & S. F. RR.

BRAY, T. A; Pay Down Woolen Mill; (**W**) Skirts, Flannels, Jeans, Blankets, Yarns; 1 set; 4 looms; water; dye; sell direct.

**St Joseph.** A. T. & S. F. RR.; C. B. & Q. RR.; C. G. W. RR.; C. R. I. & P. RR.; M. P. RR.; S. J. & I. RR.

BUELL MFG. CO.; \$200,000; I. O. Farleigh, (**W**) pres.; John S. Lemon, treas. and sec.; Percy L. Clay, gen'l mgr; J. E. Custer, supt; Blankets, Robes, Flannels, etc.; 8 sets; 374 wool spindles; 57 broad looms; steam; dye; P. L. Clay and J. E. Custer buyers; Farrish-Stafford Co., N. Y., s. agts. (Buy cotton warp 1/14s to 1/20s.)

**St. Louis.**

AMERICAN MFG. Co; Rialto Bldg; Jute (**J**) Bagging; 100 looms; steam. (See New York and Brooklyn, N. Y., for officers, etc.)

HALL MFG. Co, W. A.; 2909 No. 20th St; (**K**) Wm. A. Hall, pres; E. L. Hall, treas. and sec; F. J. Hall, supt; Surgical Elastic Hosiery, Supporters, etc; 6 knitting machines; hand power; sell direct.

HOME COTTON MILLS Co.; 2nd and (**C**) Barton Sts; \$100,000; J. M. Bemis, pres; J.

S. Bemis, treas. and agt; C. A. Young, supt. and buyer; Bag Goods, Flour Sacks; 1,194 spindles; 361 looms; steam; Bemis Bros. Bag Co., s. agts.

LUNSTRAS DYEING & CLEANING Co.; (**D&F**) Park Ave.; Re-dyeing and Re-finishing Piece Goods and Cleansing Garments, etc. MAYFIELD WOOLEN MILLS CLOTHING Co.; (see mills at Louisville, Ky.)

MISSOURI COTTON BATTING & MFG. Co.; (**C**) (incorp. 1895); \$6000; 300 Lynch St.; Albert R. Nauer, pres. and supt; Henry W. Koch, sec. and treas; Cotton Twine, Batts, Mop Yarns and Wicks; 2000 ring spindles; steam; sell direct. Henry W. Koch and A. R. Sauer, buyers.

POSNANSKY, MAX, HOSIERY Co.; 1810 So. (**K**) Broadway; Heavy Wool Hosiery and Caps; 50 knitting machines; hand power; sell direct; M. Posnansky, buyer.

PREMIER HOSIERY MILLS; 115 Market (**K**) St; \$15,000; Wm. G. Hills, prop; Paul F. Vogel, pres. and supt; John Olthmann, treas.; Men's Fine Gauge Half Hose; 40 knitting machines; steam and electric; dye and finish; sell direct; Paul F. Vogel, buyer.

ST. LOUIS CORDAGE Co; Menard Street (**J**) Mill; Binding Twine and Rope; 400 spindles. In plant formerly occupied by St. Louis Cotton Mills Co.)

**Sedalia.** M. K. & T. RR.; M. P. RR.; S. W. & S. RR.

LAMY, J. A. MFG. Co; J. A. Lamy, pres; (**W**) E. Lamy, treas; J. M. Cain, supt; all Wool and Cotton Warp Cassimeres; 1 set; 8 looms; steam; dye; sell direct.

RICHTER, J. B.; Cotton and Woolen (**K**) Seamless Hosiery; 6 knitting machines; dye; sell direct. (Buy 8 to 16 yarn.)

**West Plains.** K. C., Ft. S. & M. RR.

WEST PLAINS WOOLEN MILLS; W. J. (**W**) Zorn, prop; Chas. Cooper, mgr; Stocking Yarns; 1 set; steam; dye; sell direct.

**MONTANA.**

No map.

For explanation of abbreviations see page 66.

**Big Timber.** N. P. RR.

SWEETGRASS WOOLEN MILL; \$50,000; (**W**) William Whitfield, pres. and gen'l mgr.; E. O. Clark, vice pres.; John F. Asbury, treas.; Henry Nicholson, sec.; Blankets

and Flannels; 1 set; 6 looms; steam; dye; sell direct.

**Billings.** N. P. RR.

ALLEN, DR. W. A., and others interested (**W**) in erection of a woolen mill. *Projected.*

**NEBRASKA.**

No map.

For explanation of abbreviations see page 66.

**Beatrice.** B. & M. RR., U. P. RR.

BEATRICE RUG FACTORY; Henry E. (**W**) Wiens, mgr.; 506 Ella St.

**Fremont.** C. & N. R'y; U. P. R'y.

NEBRASKA BINDER TWINE CO; \$40,000; (**FI**) J. F. Hanson, pres. and treas; American Rough and Carded Hemp; steam; sell direct.

**Kearney.** C. B. & Q. RR.; K. & B. H. D. RR.; U. P. R'y.

KEARNEY COTTON MILLS; \$150,000; James (**C**) J. Hooker, pres.; Chas. N. Brown, treas. and buyer; H. R. Weston, supt; Brown

Cotton Sheeting; 9216 ring and 6272 mule spindles; 416 looms; steam and water; Putnam, Hooker & Co, Cincinnati, and St. Louis, s. agts. *Not running, machinery will probably be removed.*

**Omaha.**

BEMIS BROS. BAG Co.; Blankets (**W** & **C**) and Bags. (Erecting new mill.) (Office 89 State St., Boston.)

OMAHA NATIONAL KNITTING FAC. (**K**) TORY; J. F. Bilz; Hosiery, Cardigan Jackets, Sweaters, Golf Hose, etc.; 20 knitting machines; hand power; sell direct.

**NEW HAMPSHIRE.**

See map on page 144.

For explanation of abbreviations see page 66.

**Antrim.** H-4. B. & M. RR, Con. Div.

COCHRANE, C. B.; Fishing Lines, Laces, & C&S etc.; 25 braiders, buys yarn; water; sells direct. *Not running, may resume sometime.*

**Ashland.** F-5. C. & M. RR.

ASHLAND KNITTING CO.; \$100,000; Geo. E. (K) Scribner, treas.; Ladies', Misses' and Men's Woolen Hosiery; 7 sets; 125 knitting machines; water; dye; sell direct and Thos. S. Fuller, 70 & 72 Franklin St., N. Y., s. agts.

HART, ROBT. II.; Squam Lake Mill; (W) Cassimeres and Suitings; 5 sets; 27 looms; steam and water; dye.

**Ashuelot.** J-3. B. & M. RR. Conn. Riv. Div.

ASHUELOT WARP CO.; S. W. Maxfield, (C) treas.; P. G. Maxfield, supt.; Cotton Warps on Beams; 2880 ring spindles; water; sell own goods; S. W. Maxfield, buyer. (Buy 14s to 24 yarns on tubes, section slasher beam and ball warps.)

ASHUELOT WOOLEN CO.; \$10,000 L. F. (W) Dickinson, pres.; F. L. Felch, treas.; Tibbets, Beavers and Friezes; 4 sets; 25 looms; water; dye; Frank Victor & Achels, s. agts.; L. F. Dickinson, buyer.

SHERIDAN, HUGHL.; Sheridan Woolen (W) Mills; Ralph J. Sheridan, supt.; Suit ings, Overcoatings and Cloakings; 11 sets; 40 looms; steam and water; dye; Harris & Stern dept. Schnabel Bros., s. agts. (Operating mill of Jas. S. Gill Estate.) (Formerly at Great Barrington, Mass.)

**Barnstead.** G-6. C. & M. RR.

PICKERING, J. C.; Yarn, etc.; 1 set; 3 (W & K) looms; 2 knitting machines; water; dye; sell own goods.

**Belmont.** G-5. C. & M. RR.

GILMANTON MILLS; \$100,000; Amory A. (K) Lawrence, pres.; Frank I. Eustis, Boston, treas.; Moses Sargent, agt.; Ladies' and Misses' Hosiery; 3000 mule and 1020 ring spindles; 300 knitting machines; water and steam; dye; Lawrence & Co., Boston and N. Y., s. agts.; Frank I. Eustis, buyer.

**Bristol.** F-5. B. & M. RR, Con. Div.

DODGE DAVIS MFG. CO.; \$150,000; H. C. (W) Whipple, pres. and treas.; Fine Flannels; 11 sets; 70 broad looms; water; dye; sell own goods; H. C. Whipple, buyer. (Buy fine cotton yarn.)

**Campton Village.** E-5. C. & M. RR.

DOLE, E. & Co.; Cassimeres, Flannels, (W) Satinets; 2 sets; 8 looms; water; dye and finish; sell direct.

**Claremont.** G-3. B. & M. RR, Conn. Riv. Div.

CLAREMONT WOOLEN CO.; J. R. Barney (W) and W. H. Slack; Shoddy; 3 sets; 2 pickers; 3 flock cutters; also machines for scouring waste; water.

MONADNOCK MILLS; \$250,000; Francis J. (C) Parker (Boston), treas.; F. P. Vogl, agt.; Sheetings, Satin and Marseilles Quilts; 14,656 ring spindles; 391 broad looms; steam and water; bleach; Parker, Wilder & Co., N. Y. and Boston, s. agts.; Frank P. Vogl, buyer.

ROBERTS, A. & Co.; Balcobm Mill; (W) (formerly at Haverhill, Mass.); Worsted Suitings and Wool Cheviots; 3 sets; 21 looms; steam; dye; sell direct; 104 Franklin St., N. Y.; John Roberts, buyer.

**Colebrook.** B-5. Main Cent.

LOMAS, WM. A.; Cassimeres, Flannels, (W) Yarns and Rolls; 1 set; 3 looms; water; sell direct.

**Contoocook.** H-5. B. & M. RR, Conn. Div.

CONANT MFG. CO.; \$15,000; D. E. Conant, (S) pres. and supt.; F. E. Conant, sec. and treas.; Organzine, Tram, Machine Twist, Spun Silk; 4000 spindles; water and steam; F. E. Conant, buyer.

**Dover.** H-7. B. & M. RR. West Div.

COCHECO MFG. CO.; \$1,500,000; T. J. (C, Pr, H) Coolidge, pres.; A. B. Silsbee, treas.; Chas. H. Fish, agt.; Print Cloths; 65,000 ring and 52,000 mule spindles; 3000 looms; steam and water; dye and bleaching and print works; Lawrence & Co., s. agts. C. H. Fish, buyer.

SAWYER MILLS (American Woolen Co.); (W) Wm. M. Wood, (Boston), treas.; Chas. F. Sawyer, agt.; Staple and Fancy Woolen Suitings, Trouserings, 38 sets; 150 looms; water and steam; dye; J. C. Woodhull, N. Y., s. agt.; H. J. Potter, (Boston), buyer.

**East Andover.** G-5. B. & M. RR. Con. Div.

BRSIEL, H. M.; Wool Shaker Socks; 1 (K) set; 9 knitting machines; water; dye; sell direct.

**East Canterbury.** G-6. C. & M. RR.

SHAKER KNITTING CO.; Hart & Shepard, (K) trustees; Sweaters, Men's Half Hose, Bicycle Hose and Toques; 8 knitting machines; steam; sell own goods; Hart & Shepard, buyers. (Buy all wool yarns.)

**East Jaffrey.** J-4. Fitch. RR, Ches. Div.

WHITE BROS.; (P. O. address, Winch. (C)endon Springs, Mass.) Denims, Ticks; 11,000 ring spindles; 390 looms; water; dye; sell direct.

**East Rochester.** G-7. P. & R. RR.

COCHECO WOOLEN MFG. CO.; \$150,000; (W) Wm. H. Sherman, pres.; Benj. Phipps, treas.; E. M. Sinclair, agt.; Fancy Cassimeres, Suitings, Outing Flannels, Meltons, Coverts and Broadcloths; 18 sets; 122 looms; steam and water; dye; Parker, Wilder & Co., Boston and N. Y., s. agts.

**Enfield.** F-4. B. & M. RR, Con. Div.

BALTIC MILLS; (American Woolen Co.) (W) Wm. M. Wood, (Boston), treas.; Geo. E. Whitney, agt.; Thomas F. Crowe, supt.; Overcoatings; 5 sets; 100 looms; water and steam; dye; J. C. Woodhull, N. Y., s. agt.; H. J. Potter, (Boston), buyer.

FIRST FAMILY OF SHAKERS; John Brad. (K)ford, trustee; Hosiery and Sweaters; 4 knitting machines; water.

**Exeter.** H-7. B. & M. RR, West Div.

EXETER MFG. CO.; \$325,000; Hervey Kent, (C) pres.; Geo. E. Kent, treas. and agt.; Dennis McGraw, supt.; Cambrics and Shirts; 40,000 spindles; 1000 looms; water and steam; Converse, Stanton & Co., Boston and N. Y., s. agts.; G. E. Kent, buyer.

**Franklin Falls.** G-5. B. & M. RR, Con. Div.

AIKEN'S, WALTER, SONS; M. Duffy, supt.; (K) Woolen Hosiery; 9 sets; 275 knitting machines; water; dye; Eldredge, Lewis & Co., N. Y. and Boston, s. agts.; M. Duffy, buyer.

FRANKLIN MILLS; (See M. T. Stevens & (W) Sons Co., No. Andover, Mass.); W. C. Damon, supt.; Ladies' Broadcloths, and Dress Goods; 16 sets; 122 looms; water; dye.

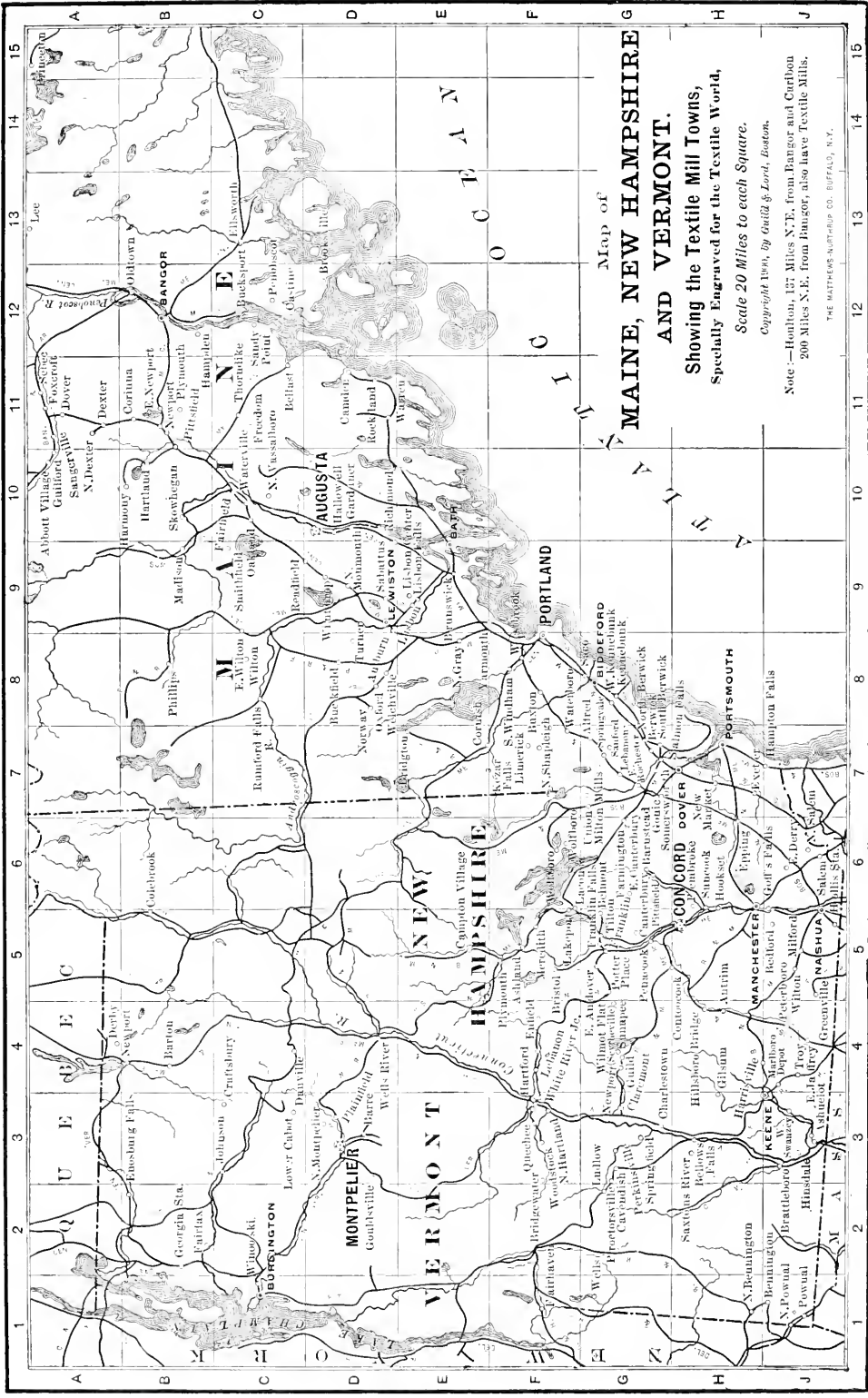

Map of  
**MAINE, NEW HAMPSHIRE  
 AND VERMONT.**

Showing the Textile Mill Towns,  
 Specially Engraved for the Textile World,

Scale 20 Miles to each Square.

Copyright 1906, by Gould & Lord, Boston.

Note.—Houlton, 127 Miles N.E. from Bangor and Corhoun  
 200 Miles S.E. from Bangor, also have Textile Mills.

THE MATTHEWS MAP-ENGRaving CO., BUFFALO, N. Y.



- SULLOWAY MILLS;** \$250,000; Frank L. (K) Morrison, pres.; A. W. Sulloway, treas.; Fred'k H. Daniell, supt; Hosiery, Cotton, Wool, Merino; 8 sets; 250 knitting machines; water; dye; E. M. Townsend & Co, N. Y., s. agts.; Fred'k H. Daniell, buyer. (Buy cotton yarn, 11s to 40s; worsted, 20s to 45s.)
- Gilsun.** G-4. Stage at Keene on B. & M. RR, So. & Conn. Riv. Divs. and Fitch. RR.
- COLLINS, JOHN S. & Co;** Beavers and (W) Cheviots; 4 sets; 28 looms; steam and water; dye; buy worsted yarn; Oelbermann, Dommerich & Co, N. Y., s. agts.
- GILSUM WOOLEN MFG. CO;** \$25,000; H. (W) E. Adams, treas.; R. Polzer, supt; Worsteds; 3 sets; 26 broad looms; water and steam; dye; buy worsted 2/18 to 2/42; Brigham, Lawrie, Mann & Drowne, N. Y., Blake & Stearns, Boston, s. agts.
- Goff's Falls.** J-6. C. & M. RR.
- DEVONSHIRE MILLS;** \$100,000; Edwin (W) Smith, pres.; E. A. Hatch (Boston), treas.; Thos. Walker, Jr, supt. agt and buyer; Cloakings and Cassimeres; 13 sets; 56 looms; water and steam; dye; The Allen Lane Co, N. Y., and Boston, s. agts.
- Gonic.** G-7. B. & M. RR, W. Div.
- GNIC MFG. CO;** \$100,000; W. H. Sher. (W) man (Boston), pres.; Benj. Phipps (Boston), treas.; S. C. Meader, agt; J. E. Meader, supt; Wool Flannels, All-wool Dress Goods and Suitings; 12 sets; 100 looms; steam and water; dye; Parker, Wilder & Co, Boston and N. Y., s. agts.
- Great Falls.** Now called Somersworth, which see.
- Greenville.** J-5. Fitch. RR.
- COLUMBIAN MFG. CO;** \$350,000; Chas. H. (C) Fisher, pres.; Geo. F. Fabyan (Boston), treas.; F. W. Ely, agt.; Denims, Stripes, Ticks, Shirtings, etc.; 20,000 ring spindles; 636 looms; steam and water; dye; Bliss, Fabyan & Co., N. Y. Boston, Phila. and Chicago, s. agts.; F. W. Ely, buyer. (Branch mill at New Ipswich included in above data.)
- Guild.** G-7. B. & M. Con. Div.
- GRANITE STATE MILLS;** Fairbanks & (W) Dorr; Twills and Repellents; 5 sets; 48 looms; water; dye; F. Victor & Achelis, N. Y., s. agts.
- Harrisville.** H-4. B. & M. RR, So. Div.
- CHESHIRE MILLS CO;** H. Colony, pres. (W) treas. and agt; Jas. Pierce, supt; Plain and Twilled Colored Flannels, Dress Goods; 9 sets; 44 looms; water; dye; Faulkner, Page & Co, Boston and N. Y., s. agts; H. Colony, buyer.
- Hillsboro Bridge.** H-4. B. & M. RR, Con. Div.
- CONTOCOOK MILLS;** \$150,000; J. B. (K) Smith, (Boston), pres.; Geo. E. Gould, treas.; Underwear and Hosiery; 10 sets; 200 knitting machines; water; dye; sell direct; Geo. E. Gould, buyer.
- HILLSBORO WOOLEN MILL CO;** R. F. (W) Greeley, treas.; J. H. Kimball, agt.; Geo. W. Haslet, supt.; Kerseys, Doeskins and Granites; 15 sets; 57 looms; water; Greeley, Cushman & Record, s. agts.
- Hinsdale.** J-3. B. & M. RR, Conn. Riv. Div.
- AMIDON, CHAS. J. & SONS;** C. E. Weeks, (W) supt; Cashmerettes, Meltons, Flannels, Cheviots; 6 sets; 60 broad looms; water; dye; Battelle, Hurd & Co, N. Y. and Boston, s. agts.
- HAILE & FROST MFG. CO. THE;** \$150,000; (W) Rufus F. Greeley, pres.; Henry C. Haile, treas.; Chas. Bigelow, gen'l mgr.; R. A. Clogher, supt.; Kerseys and Suitings, all Wool and Cotton Warps; 15 sets; 112 looms; steam and water; dye; Greeley, Cushman & Record, Boston & N. Y., s. agts.
- Hollis Depot.** J-5.
- CLIFFORD, C. A.;** Plain and Fancy Baek (K) Double Mittens; 15 knitting machines. (Buys yarn.)
- Hookset.** H-6. C. & M. RR.
- DUNDEE MILLS;** \$200,000; F. E. (C F I & D) Cox (Wakefield, Mass.), treas.; S. W. Bourne, agt.; Towels and Crash; 17,000 spindles; 427 looms; steam and water. Also Dyers of Raw Stock and Yarn. (Purchased plant of Hookset Mfg. Co.)
- Keene.** J-3. B. & M. RR, So. Div. and Conn. River Div.
- FAULKNER & COLONY MFG. CO;** \$100,000; (W) Frederic A. Faulkner, pres.; John C. Faulkner, treas.; All-wool Flannels, Suitings and Dress Goods; 10 sets; 50 looms; water and steam; dye; Faulkner, Page & Co, N. Y. and Boston, s. agts.
- Laconia.** F-6. C. & M. RR.
- BUSTEL, J. W., & Co;** 54 Mill St.; Grani e (K) Hosiery Mills; Woolen Hosiery; 7 sets; 250 knitting machines; water; dye; Shreve & Adams, N. Y., s. agts.
- ESTY HOSEIERY CO;** 59 Mill St.; \$100,000; (K) Wm. Esty, pres.; Fred A. Phelps, treas.; Hosiery, Woolen and Cotton; 200 automatic knitting machines; water; dye.
- HODGSON, E. A.;** 130 Union Ave.; Sam (D) Hodgson, agt; (formerly McLaughlin & Son); Hosiery and Raw Stock Dyers, Woolen Extract and Mixed Stock a specialty; also stock carded and picked
- MORIN, J. P., & Co, Index Knit (K) ting Co;** 40 California Court; J. P. Morin, pres. and treas.; Infants' and Misses' Woolen Hosiery; 45 knitting machines; water; E. M. Townsend & Co., N. Y., s. agts.
- O'SHEA, DENNIS;** (successor to O'Shea (K) Bros.); O'Shea Bros., props; Misses', Ladies' and Children's Seamless Hosiery; 4 sets; 100 knitting machines; electricity; William Iselin & Co, N. Y., s. agts. *Not running.*
- PITMAN MFG. CO;** 100 Union Ave; Chas. F. (K) Pitman, pres.; J. Pitman, treas.; G. E. Stevens, supt; Ladies', Misses' and Boys' Woolen and Cotton Hosiery; 7 sets; 285 knitting machines; water; dye; Hinchman, Vezin & Co, N. Y., s. agts; Chas. F. Pitman, buyer.
- ROWE & Co;** 44 California St.; All wool (W) and Merino Yarns; 4 sets; 1 picker; water; sell direct.
- ROWE, F. B. & Co;** 57 Mill St.; F. B. (K) Rowe, supt; Cotton and Woolen Hosiery; 145 knitting machines; water; sell direct; F. B. Rowe, buyer.
- TILTON, G. H.;** 128 Union Ave.; Wool, Cot. (K) ton and Merino Hosiery; 5 sets; 425 knitting machines, water; T. S. Fuller, N. Y., s. agt. (Also mill at Columbia, S. C., J. M. Graham, mgr, and Savannah, Ga.) Finishing and dyeing dept. at Tilton, N. H.
- UNION HOSEIERY CO;** 44 California Court; (K) (not incorporated) Frank P. Stewart; prop.; Wool Hosiery; 25 knitting machines; water; sell direct.
- Lakeport.** F-5. C. & M. RR.
- CLOW, WM. & SON;** 28 Halifax Ct.; \$25,000; (K) H. B. Clow, treas, agt, supt. and buyer; Ladies', Misses', and Children's Wool and Worsted Hosiery; 185 knitting machines; steam and water; dye; Wm. Iselin & Co, N. Y., s. agts. (To add machinery for making yarn.)
- RUTTER BROS;** Removed to Lawrence, (W) Mass., *which see.*
- WOOD, H. H. & Co;** Oriental Mills; 34 (K) Bayside Court; H. H. Wood, pres.; B. S. Wadleigh, supt; Woolen Hosiery; 8 sets; 256 knitting machines; water; dye; sell direct; 51 Leonard St., N. Y.

**Lebanon.** F.4. B. & M. RR, Con. Div.

CARTER & ROGERS; Repellents; 4 sets; (W) 60 looms; water; dye; Deering, Milliken & Co, N. Y. and Boston, s. agts; Geo. S. Rogers, buyer.

EVERETT KNITTING WKS; \$150,000; F. B. (K) Kendrick, pres; Geo. S. Rogers, treas; and mgr; R. B. Jacobs, supt; Ladies' and Children's Fancy Ribbed Underwear; 65 knitting machines; steam and water; Wm. Iselin & Co, N. Y., s. agts; R. B. Jacobs, buyer.

LEBANON MILLS; (American Woolen (W Co.)) Wm. M. Wood, (Boston), treas; Geo. E. Whitney, agt; Flannels, Blankets and Dress Goods; 17 sets; 128 broad looms; water and steam; dye; J. Clifford Woodhull, N. Y., s. agt.

**Lisbon.** D-4. (Not shown on map.) B. & M. RR.

GRANITE STATE ELECTRICAL WORKS; (\$ 225,000; H. C. Libbey, pres.; W. M. Parker, sec. and treas.; Cotton and Silk Covered Wire.

NEW ENGLAND ELEC. WORKS; (C prop.); Wire Covering.

**Manchester.** H-6. C. & M. RR. and B. & M. RR.

AMORY MFG. Co.; \$900,000; T. J. Cool (C) lidge, pres; F. C. Dumaine, treas; Geo. F. Whiten, agt. and buyer; Sheeting, Shirtings, Sateens and Jeans; 56,358 ring and 70,898 mule spindles; 3023 looms; water and steam; C. L. Bausher & Co, N. Y. and Boston, s. agts.

AMOSKEAG MFG. Co.; \$4,000,000; Geo. A. (C) Gardner, pres.; C. W. Amory, (Boston), treas; H. F. Straw, agt; Chas. H. Manning, supt; Ticking, Denims, Shirting, Stripes, Cotton Flannels, Ginghams; 300,000 spindles; 10,700 looms; water and steam; dye; Noyes, Bausher & Gerrish, N. Y., s. agts.

BICYCLE HOSIERY Co.; W. Auburn & (K) Franklin Sts.; Geo. W. Rief, prop; Bicycle Hosiery; 20 knitting machines; steam; dye; H. C. Mathews, N. Y., s. agt.

ELLIOTT MFG. Co.; cor. Wilson & Valley (K) Sts.; \$150,000; Frank Dowst pres; W. N. Johnson, treas; Edward Dorsey, agt. and buyer; Wool and Silk Knit Underwear; 150 knitting machines; 100 sewing machines; steam; Roger Lamson & Co., 55 Leonard St., N. Y., s. agts.

MANCHESTER MILLS; \$2,000,000. (C, W, Pr & D) 000; Nat'l J. Rnst, pres; Chas. W. Jones, treas; C. D. McDuffie, agt; Geo. A. Clark, and Clarence Bancroft, supts; Worsted and Cotton Dress Fabrics, Prints, etc; 22 combs; 75,000 cotton spindles; 21,000 worsted spindles; 3300 looms; steam and water; dye and print works; Minot, Hooper & Co, Boston, Phil. and New York, s. agts.

MANCHESTER STOCKING Co.; H. P. Ray, (K) prop; Men's Wool, Merino and Camels' Hair Seamless Hosiery; 3 sets; 70 knitting machines; steam; dye; sell direct.

OLZENDAM, A. P., HOSIERY Co.; \$200,000; (K) A. H. Olzendam, pres; G. A. Olzendam, treas. and agt; Benl. J. Craggy, supt; Cotton and Woolen Hosiery; 13 cards; 4620 woolen spindles; 400 knitting machines; water and steam; dye; Fred'k Victor & Achelis, N. Y., s. agts. G. A. Olzendam, buyer. *Receivers appointed March, 1902.*

STARK MILLS; \$1,250,000; H. S. Gray, pres.; (C) pres; Sidney Coolidge, treas; John H. Whiten, supt.; Sheetings, Shirtings, Drills, Ducks, Hosiery Yarns and Grain Bags; 83,000 spindles; 2500 looms; steam and water; Noyes, Bausher & Gerrish, N. Y., s. agts.

**Marblehead.** J-1. B. & M. RR, So. Div.

CHESHIRE BLANKET Co.; Valley Woolen (W Mills); C. O. Whitney, treas; Horse Blan-

kets and Satinets; 7 sets; 72 looms; steam and water; Chas. W. Sabin, Boston, Stevens, Sanford & Handy, N. Y., s. agts.

RICHARDSON & PEASE; Horse Blankets (W) and Blanket Cloth; 4 sets; 30 looms; water and steam; Allen-Lane Co, Boston and N.Y., s. agts. E. P. Richardson, buyer.

TOWNSEND, JAMES F.; (Pioneer Mills); (W) D. K. Townsend, agt; Yarns and Bed Blankets; 1 set; 3 looms; water; dye; sell direct.

**Meredith.** F-5. C. & M. RR.

ATLAS LINEN Co.; \$170,000; Thomas (F) Allen, pres.; W. F. Corne, treas.; Linen Goods; 100 looms; steam and water; Whitman & Phelps, N. Y., s. agts.

**Milford.** J-5. B. & M. RR. So. Div.

MORSE & KALEY MFG. Co.; (Am. Thread (C Co.)); \$50,000; R. C. Kerr, pres; F. E. Kaley, treas.; Knitting Cotton and Yarn; 3000 ring spindles; water and steam; American Thread Co., s. agts.

QUINLAN, JOHN, & Co.; Bleachers of (B) Yarns, Cloths, Linen and Hemp; steam.

**Milton Mills.** G-7. Stage from Union on B. & M. RR, No. Div.

TOWNSEND, H. H.; John E. Townsend, (W) supt.; Bed Blankets and Plaid Blankets for Wrappers and Bath Robes; 3 sets; 21 looms; steam and water; dye; Thos. Kelly & Co., Boston, s. agts.; H. H. Townsend, buyer.

**Nashua.** J-5. B. & M. RR, So. Div. and C. & M. RR.

BAKER, MRS. LUCY R. (11 Lock St); (K) Mittens, Gloves and Infants' Underwear; 80 knitting machines.

JACKSON Co.; \$600,000; Howard Stockton, (C) pres; Frederic Amory (Boston), treas; W. H. Cadwell, agt; A. A. Milliken, supt; Sheetings, Flannels; 48,976 ring spindles; 1506 looms; steam and water; Amory, Browne & Co, Boston, N. Y. and Phila, s. agts; W. H. Cadwell, buyer.

NASHUA MFG. Co.; \$1,000,000; (C, Pr, B) Chas. P. Bowditch, pres; Frederic Amory, treas; Wm. D. Cadwell, agt. and buyer; R. Milliken, supt; Cotton Flannels, Sheeting, Shirtings and Blankets; 90,000 spindles; 2,574 looms; water and steam; dye house and bleachery; Amory, Browne & Co, Boston and N. Y., s. agts.

LATOIE, N. D. *Out of business.*

**New Market.** H-7. B. & M. RR, W. Div.

NEW MARKET MFG. Co.; \$800,000; D. L. (C & S) Pickman, pres; Linzee Prescott, treas; Joseph D. Aiken, agt.; Shirtings, Sheetings, Drills, etc.; Pongees, Mulls, et.; 54,128 ring and 5,088 mule spindles; 1944 cotton, 400 silk looms; steam and water; Joy, Langdon & Co., Boston and N. Y., s. agts.; Joseph D. Aiken, buyer.

**Newport.** G-4. B. & M. RR, Con. Div.

RICHARDS', DEXTER & SONS; Sugar River (W) Mill; H. W. Brown, supt.; Flannel Shirtings and Ladies' Dress Goods; 12 sets; 60 looms; water and steam; dye; H. & W. H. Lewis and Battelle, Hurd & Co., s. agts.; H. W. Brown and owners, buyers.

**No. Salem.** J-6. B. & M. RR, Manchester & Lawrence Br.

ROCKINGHAM MILLS; Worsted Yarns; (W) Spinning from Top; steam and water; Wm. H. A. Fischer, N. Y., s. agt. Freight address, Camobie Lake.

SLACK, JOHN; New Hampshire Hair (C) Works; Hair Cloth; 12 looms; steam and water; sell direct.

**Penacook.** G-5. Electric cars from Concord, on B. & M. RR, No. Div.

- BOSSAWEN MILLS;** \$50,000; Geo. M. Kim (C) ball, pres; S. C. Eastman, treas; F. E. Wattles, agt.; J. Mahoney, supt.; Hosiery Yarns, 4s to 16s, High Grade Cords for Hose and Belt Mfgs. and Special Purposes; 3,000 ring spindles; water; sell direct; S. C. Eastman, buyer.
- CONCORD MFG. CO;** (mills also at West (W) Concord;) \$150,000; F. P. Holden, pres; Paul R. Holden, treas; James M. Masson, supt.; Mens' Wear Woolens; 5 sets (W. Concord); 6 sets (Penacook); 38 looms (W. Concord); 44 (Penacook); water and steam; dye; Parker, Wilder & Co., Boston, s. agts.; Paul R. Holden, buyer. (Buy fancy yarns.)
- DUSTIN ISLAND WOOLEN MILLS;** \$40,000; (W) S. G. Harris, pres.; A. G. Harris, treas.; R. L. Harris, supt.; Dress Goods; 5 sets; 30 broad looms; water and steam; dye; Faulkner, Page & Co., Boston and N. Y., s. agts.; R. L. Harris, buyer.
- NEW HAMPSHIRE SPINNING MILLS;** \$200, (C) 000; Marcellus Gould, pres, and mgr; H. H. Dudley, treas; Combed Sea Island and Egyptian Yarns, from 30s to 80s, skeins, cones, warps, single and twisted; 12,450 ring spindles; water; Am. Cotton Yarn Exchange, s. agts.; Marcellus Gould, buyer.
- Peterboro.** J.4. B. & M. RR, Ches. Div, and B. & M. RR, Con. Div.
- JOSEPH NOONE'S SONS CO, THE;** A. W. (W) Noone, prop.; Woolen Specialties for Mechanical Purposes; 4 sets; 26 looms; steam and water; dye; W. R. Noone & Co., Boston, s. agts.; A. W. Noone, buyer. (Buy 22 and 14 cotton yarns, use 14 linen yarn.)
- PHENIX MFG. CO;** \$100,000; Benj. Phipps, (C) pres, and treas; Wm. Ames, agt; Cotton Sheetings, Domets and Yarn; 5000 ring spindles; 152 looms; steam and water; Parker, Wilder & Co., s. agts.
- UNION MFG. CO;** \$100,000; Benj. Phipps (C) (Boston), treas; W. T. Butler, agt; Crochet Quilts, Towels, Sateens, etc; 3,000 ring spindles; 60 broad, 150 narrow looms; water; Parker, Wilder & Co., s. agts.; W. T. Butler, buyer supplies; Parker, Wilder & Co., buy cotton and yarn. (Buy 9/2 and 14/3 yarn on cones and in chains.) Mill at W. Peterboro.
- Pittsfield.** G.6. C. & M. RR.
- PITTSFIELD MILLS;** (leased by the Exeter (C) Mfg. Co, Exeter, N. H.); Geo. E. Kent, prop., treas, and buyer; Sheetings; Bleached; 12,240 spindles; 335 looms; steam and water; Converse, Stanton & Co, Boston, Phila., Chicago and N. Y, s. agts.
- Rochester.** G.7. B. & M. RR, W. N. & P. Divs., and P. & R. RR.
- NORWAY PLAINS CO.;** water and steam. (W) *Not running.*
- ROCHESTER WOOLEN CO.;** C. E. & H. E. (W) Clark, props.; Repellent; 8 sets; 40 looms; steam and water; dye; Victor & Achelis, N. Y., s. agts. (Purchased upper mill of Norway Plains Mfg. Co.'s mill.)
- Salem.** J.6. B. & M. RR, Manchester & Lawrence Br.
- WHEELER, J. W. & SON;** Suitings and (W) Flannels; 5 sets; 22 looms; water; dye; Faulkner, Page & Co, Boston, s. agts.
- Salem Depot.** J.6. B. & M. RR, Man. & Law. Br.
- MEYER THREAD CO.;** (80 Kingston St. (C&S Boston); Threads and Spool Silks. *Failed 1901. Reported reorganizing.*
- Salmon Falls.** G.7. B. & M. RR.
- SALMON FALLS MFG. CO;** \$600,000; Amory (C) A. Lawrence, pres; Geo. H. Edwards (Boston), treas; O. S. Brown, agt; Sateens, Lawns and Fancy Cottons; 56,000 spindles; 1456 looms; steam and water; Lawrence & Co, Boston, s. agts. O. S. Brown, buyer.
- Somersworth.** G.7. B. & M. RR, W. & E. Div.
- GREAT FALLS BLEACHERY AND (BI & D) DYE WORKS;** Edward P. Nichols, treas Walter S. Lawson, agt; Bleaching and Dyeing; Cottons; 150,000 yards per day; water; dye.
- GREAT FALLS MFG. CO;** \$1,500,000; Geo. (C) P. Gardner, pres; Edward P. Nichols, treas; Chas H. Plummer, agt; Sheetings, Shirtings, Drills, Sateens, Jeans and Twills; 81,332 ring and 46,408 mule spindles; 2972 looms; water; dye; Minot, Hooper & Co, N. Y. and Boston, s. agts.
- GREAT FALLS WOOLEN CO;** \$100,000; F. (W) H. Meserve, pres, and treas.; Worthington Locke, agt., supt. and buyer; Kerseys, Cloakings, Army Cloths and Dress Goods; 10 sets; 55 looms; water; dye; Deering, Milliken & Co., 79 Leonard St., N. Y., s. agts.
- So. Wolfboro.** F.6. B. & M. RR No. Div., and Steamer from The Weirs or Ailton Bay in summer.
- WOLFBORO WOOLEN MILLS;** \$75,000; C. (W) W. Springfield, pres., treas, and agt.; Fine Bed Blankets; 4 sets; 25 broad looms; steam and water; dye; Parker, Wilder & Co., Boston, s. agts.; C. W. Springfield, buyer. (Buy cotton yarns, 12, 16, 20, 30.)
- Suncook.** H.6. In Pembroke on C. & M. RR.
- CHINA MFG. CO;** \$800,000; B. R. Weld (C) (Boston), treas; D. L. Jewell, agt; E. E. Truesdell, supt; Print Cloths; 26,444 ring and 21,312 mule spindles; 1200 looms; steam and water; B. R. Weld, 131 Devonshire St, Boston, s. agt.
- PEMBROKE MILLS;** \$300,000; B. R. Weld (C) (Boston), treas; D. L. Jewell, agt; E. E. Truesdell, supt; Print Cloths; 7965 ring, and 9224 mule spindles; 422 looms; steam and water; B. R. Weld, s. agt.
- WEESTER MFG. CO;** \$500,000; B. R. Weld (C) (Boston), treas; D. L. Jewell, agt; E. E. Truesdell, supt; Print Cloths; 18,896 ring and 16,960 mule spindles; 875 looms; steam and water; sell direct.
- Tilton.** G.5. B. & M. RR.
- CARTER & MORRISON;** Buell Mills; E. G. (W) Morrison, supt.; Dress Goods and Cloakings; 5 sets; 32 looms; water; dye; finish done at Elm Mills Woolen Co.; Deering Milliken & Co., N. Y., s. agts.
- ELM MILLS WOOLEN CO;** O. G. Morrison, (W) pres; E. G. Morrison, treas, and supt; Dress Goods, Repellants and Cheviots; 6 sets; 66 broad looms; water; dye; Deering, Milliken & Co., N. Y., s. agts.
- MORRISON, O. & E. G.;** Shoddy and Ex. (W) tracts; 8 sets; 4 pickers; water and steam.
- TILTON, G. H.** (Finishing dept. only.) (K) Also see Laconia, N. H. and Savannah, Ga.
- TILTON MILLS;** \$150,000; William H. (W) Moses, treas.; A. S. Ballantyne, supt.; Fancy Cassimeres; 9 sets; 44 looms; water; dye; sell direct; 104 Franklin St., N. Y., Wm. H. Moses, buyer.
- Troy.** J.4. Fitchburg RR, Ches. Div.
- TROY BLANKET MILLS;** \$100,000; Wm. H. (W) Elliott, pres; R. H. Porter (Keene, N. H.), treas; Franklin Ripley, supt. and buyer; Horse Blankets, Coat Linings and Blanket Linings; 23 sets; 141 looms; steam and water; L. C. Chase & Co, 129 Washington St, Boston, s. agts.
- Union.** G.7. B. & M. RR, No. Div.
- UNION WOOLEN MILLS;** Arthur L. Taft (W) Sateens and Shirtings; 2 sets; 26 looms; steam and water; Stevens, Sanford & Handy, s. agts.

**W. Swanzey.** J-3. In Swanzey on Conn. Riv. RR.

W. SWANZEY MFG. CO; \$34,000; M. A. (W) Dickinson, treas. and mgr; Thomas Park, supt and buyer; Flannels; 5 sets; 46 broad looms; water and steam; dye; Fretk Amy & Co, N. Y., s. agts.

**Wilton.** J-5. B. & M. RR., So. Div.

HILLSBOROUGH MILLS; Wm. G. Abbott, (W) pres.; Nash Simons, treas., and agt.; Woolen and Worsted Yarns (Bradford system) and Blankets; 7 sets; 3600 worsted

spindles; 8 combs; steam and water; dye; W. G. Abbott, Phila., s. agt.

WILTON WOOLEN CO; P. F. Amidon, (W) treas.; C. E. Weeks, agt. and buyer; Cassimeres, Keesays and Cheviots; 8 sets; 41 broad looms; steam and water; dye; Faulkner, Page & Co., s. agts.

**Windham.** J-6. Station Windham Depot, B. & M. RR.

HOLLINGS & SMITH. *Removed to Lawrence, Mass.*

## NEW JERSEY.

See map on page 150.

For explanation of abbreviations see page 66.

**Alloway.** (Salem County.) (Not shown on map.) W. J. & S. RR.

ALLOWAY KNITTING MILLS; W. L. (K) Ewen, M. D. interested; 85 knitting machines. (Removed machinery here from Salem.)

**Athens.** D-9. P. & N. Br. Erie RR. (2½ miles from Passaic.)

EUREKA PRINTING CO.; \$40,000; J. Thorp, (Pr) treas., agt. and supt.; Printed Calicoes; steam; dye.

**Avondale.** D-9. N. Y. L. E. & W. RR, Newark Br.

CASTLE SILK CO. *Out of business.*

**Bayonne.** E-9. C. R. of N. J., Pa. RR., L. V. RR.

SCHWARZENBACH, HUBER & CO. (Branch (S) mill.) See also West Hoboken, N. J.

**Belvidere.** D-4. P. RR, Belvidere Div; L. & H. R. RR.

BAMFORD BROS. SILK MFG. CO; 5254 spin- (S) dles. (Also see Paterson, N. J., and Wilkesbarre, Pa.)

CRANE FELT MFG. CO; \$10,000; H. S. (W) Crane, pres; A. E. Crane, sec. and treas; Felts; 5 sets; steam and water; dye; sell direct.

**Beverly.** K-5. P. RR, Amboy Div.

BIRKHEAD TURNER; Beverly Hosiery (K) Mills; E. J. Birkhead, supt.; Hosiery and Underwear; 180 knitting and 75 sewing machines; steam; dye; sell direct.

MACELROY, ARCHIBALD C. MFG. CO; (C) Chas. J. McCleary, pres; A. C. McElroy, treas.; H. Gracier, supt.; Bedspreads, Curtains and Table Cloths; 26 looms; steam; bleach and dye; sell direct. (Buy yarn.)

**Bloomfield.** D-8. D. L. & W. RR, Newark & Bloomfield Br; N. Y. & G. L. RR.

EMPIRE PRINT WORKS; See Dela- (Pr & D) wanna.

OAKES, THOS. & Co; Cassimeres; 14 sets; (W) 84 broad looms; Sullivan, Vail & Co, N. Y., s. agents.

UNDERHILL, W. K. (formerly Underhill & (S) Lee); Ampere Silk Mill; A. G. Gatlher, supt.; Dress Goods; 150 looms; Oelbermann, Dommerich & Co., N. Y., s. agts.

WIGGIN'S, H. B. SONS; J. N. Wiggin, pres. (C) and gen'l mgr.; J. R. Winans, sec. and treas.; Specialties in Fabrics; J. Spencer Turner Co., s. agts.

**Bordentown.** J-6. P. RR, Bordentown Br; Amboy Div.

SPRINGFIELD WORSTED MILLS; Wm. (W) Anderson, pres; John Barry and Geo. Anderson, supts; Worsted Yarns; (Bradford System); 6 sets; 6 combs; 5,200 spindles; steam; sell direct.

**Boonton.** D-7. D. L. & W. RR, Boonton Br.

PELGRAM & MEYER; J. A. Reynar, supt.; (S) Silk Ribbons; steam; L. A. Walder, buyer; (also Paterson, N. J., and Harrisburg, Pa.)

**Bound Brook.** F-7. C. RR, of N. J; L. V. RR, New Jersey Div; P. RR, Phila, New Line, Port Reading Br.

BOUND BROOK WOOLEN MILLS; Henry (W) L. Einstein; E. A. Evans, supt; Overcoatings and Cloakings; 12 sets; 108 broad looms; steam; dye; Faulkner, Page & Co, N. Y., s. agts.

**Bridgeton.** O-3. W. J. RR, Bridgeton Br; C. RR, of N. J; Cumberland & Maurice River RR, New Jersey Southern Div.

BRIDGETON WOOLEN CO; J. G. Shaw, (W) Sr., treas. and agt.; Morris Gledhill, supt. and buyer; Overcoatings and Cassimeres; 5 sets; 38 looms; steam; dye; Duval & Cone N. Y., s. agts.

SEELEY, FRANK; Carpets. (W)

**Camden.** K-4. C. & A. RR; W. J. RR; P. RR; Camden & Burlington Rlt; A. C. RR, Gloucester Br.

BOYER, B. F. Co; Delaware Ave. and (W) Cooper St; \$50,000; B. F. Boyer, pres.; Chas. S. Boyer, treas.; B. R. Boyer, sec.; Woolen and Worsted Yarns; 3 sets; 3,600 worsted spindles; 3 cards; 3 combs (French system); steam; sell direct.

CAMDEN CURTAIN & EMBROIDERY CO; (C) Front and Pearl Sts; \$100,000; Louis Loeb, pres; Ferdinand L. Loeb, treas; Ferdinand A. Loeb, supt; also any kind of Fancy Embroideries; 50 looms; steam, Loeb & Schoenfeld, 451 Broadway, N. Y., s. agts; F. A. Loeb, buyer.

FRIES BRESLIN CO; Atlantic Ave. and (W) Ferry Road; \$75,000; J. M. Carroll, pres. and treas; T. J. Breslin, sec; Smyrna Rugs and Carpets; 300 looms; buy cotton warps, 8s-3 to 40s-3, woolen, rug and 8-ply jute yarns; steam; dye; sell direct and through W. W. Corson & Co., Boston; J. M. Carroll, buyer. (N. Y. office, 24 E. 17th St.)

HIGHLAND WORSTED MILLS; \$50,000; 9th (W) and State Sts; Hon. H. H. Voorhees, pres; J. T. Bottomley, treas; Worsted Yarns, (Bradford System); 13,500 spindles; 19 worsted cards; 18 combs; steam; sell direct; J. T. Bottomley, buyer.

HODGSON BROS; Second and Erie Sts; (W) Worsted Yarns, 2-12 to 2-40; 1600 spindles; sell direct. (Also spin on commission.)

HOLT MFG. CO; 76 Erie St; Ladies' Hose (K) and Men's Half Hose; 31 knitting machines; gas; sell direct.

HUB GORE MAKERS. *Removed to Brockton, Mass.*

- HUSSONG, JOSEPH**; Camden Dye Works; (**D**) 609 Pearl St; Dyers Woolen and Worsted Yarns, Shubbing; steam; J. Hussong, buyer.
- LINDEN WORSTED MILLS**; Howland (**W**) Croft, Sons & Co; Broadway & Jefferson Sts; Fine Worsted Yarns, 2/20s to 2/60s; (English System); 17 combs; 20 worsted cards; 12,500 spindles; steam; sell direct.
- LUNN, JOHN CO.**; 107 Erie St.; \$20,000; (**W**) Wool Scouring and Carbonizing, Burr Pickling, Willowling, etc.
- MAGUIRE, WM. J.**; 101 Market St; Uphol. (**S**) stery Trimmings; W. George Maguire, agt; 10 looms; hand power; sell direct; W. George Maguire, buyer.
- PHILADELPHIA WORSTED CO.**; 74-84 Elm (**W**) St; \$10,000; Chas. W. Thomason, pres. and agt.; A. Thomason, sec. and treas; John Hill, supt; Worsted Tops and Yarns (Bradford System); 4 worsted cards; 1800 worsted spindles; 4 combs; steam; sell direct; C. W. Thompson, buyer. (Also spin on commission.)
- SHIMER, GEO. & SON**; 5th and Erie Sts; (**W**) A. Patchett, supt; Worsted Yarns; 2 sets; 2000 spindles; 2 combs; steam; sell direct; C. R. Shimer, buyer.
- WISSAHICKON DYE WORKS**; C. P. Cur. (**D**) many; 8th and Cherry Sts; John H. Carmany, supt; Dyeing Raw Cotton, Wool, Silk Noods, Shoddy, etc.; steam.
- Carlstadt.** D-9. E. RR.
- SCHARG BROS.**; Dress Silks; 60 looms; (**S**) 260 spindles; steam; sell direct; N. Y. office, 101 Spring St.
- Carlton Hill.** D-9. N. Y, L, E. & W, Bradford Br.
- STANDARD BLEACHERY CO.**; (**BI D & F**) \$400,000; Wm. McKenzie, pres; John Ward, treas; Benj. L. Ward, asst. treas; James J. McKenzie, supt; Bleaching, Dyeing and Finishing Cotton Goods; steam; dye; J. J. McKenzie, buyer.
- Cedar Grove.** D-8. N. Y. & G. L. RR.
- BOWDEN, ANTHONY**; Batts and Lamp (**C**) Wicks; 600 spindles; water.
- Changewater.** E-5. D. L. & W. RR.
- SKERRY, A. T. & Co.**; (47 Leonard St., (**W**) N. Y.); Hopatcong Worsted Mills; Worsted Yarns, 1/4 and 3/8 blood; 16 frames; (English System); water; dye; sell direct.
- Chester.** E-6. D. L. & W. RR.
- LANCASTER, M. J. CO.**; M. J. Lancaster, (**W**) pres. and treas; Wm. Lancaster, supt. and agt; Fine Woolen Yarn, from 2-18 to 2-22, also Blankets; 1 set; 4 looms; water; dye; sell direct; Wm. Lancaster, buyer.
- Clifton.** D-9. Erie RR.
- BARCLAY SILK CO.**; Broad Silks; 50 looms; (**S**) steam; sell direct; Theodore Barclay, buyer.
- Delanco.** K-4. Penn. RR.
- STAR KNITTING MILLS.** P. H. Young, agt.; (**K**) C. E. Barnitz, supt; Specialties in Hosiery; 10 knitting machines; steam; sell direct; C. E. Barnitz, buyer.
- Delawanna.** D-9. RR. Station Passaic, 3 miles away.
- WALDRICH BLEACHERY.**; (**Br. D & F**) (owned and operated by the Worthen & Aldrich Co. (25 No. Moore St., N. Y.)); Bleaching, Dyeing, Printing and Finishing Cotton Goods, and Printing Satinets; also Works at Passaic.
- Dover.** D-7. C. RR. of N. J. High Bridge Br; D. L. & W. RR. Chester Br; Morris & Essex Div.
- GUENTHER, PAUL & CO.**; Full Fashioned (**K**) Hosiery, silk and cotton; 6 knitting machines; 3 sewing machines; steam; sell direct.
- SINGLETON, GEO.**; Matthew Tucker, (**S**) supt; Thrown Silks; 10,000 spindles; steam; dye; sell direct. (See also Port Oram, N. J., and Wadesboro, N. C.)
- SWISS KNITTING CO.**; E. G. Kattermann (**K**) & Co, props; Ladies' Ribbed Underwear Silk, Silk Mixes, Wool and Lisle Thread; 70 knitting and 30 sewing machines; steam; sell direct.
- East Orange.** E-8. D. L. & W. RR. Morris & Essex Div; N. Y. & G. L. RR. Watchung RR.
- COLLINS & AIKMAN CO.**; Plush. See Phila. (**S**)
- SEABURY & JOHNSON**; \$100,000; Geo. J. (**C**) Seabury, pres; H. C. Lovis, sec; G. W. Hopping, treas; Wm. M. Davis, supt; Absorbent Cotton, Lint and Medicated Gauzes; steam; dye; E. L. Benjamin, buyer.
- Egg Harbor City.** N-6. (RR. name, Egg Harbor); C. & A. RR., A. C. RR.
- PHILADELPHIA SILK LABEL CO.** See (**S**) *Penn Artistic Weaving Co, Phila.*
- Elizabeth.** E-8. C. RR. of N. Y. Perth Amboy Br; Newark & Elizabeth Br; P. RR., N. Y. Div.
- NORTH, JOS. W. & SONS**; Elizabeth Knit (**K**)-ting Mills; 6th and Fulton Sts; Ladies' Cotton and Wool Ribbed Underwear; (buy  $\frac{1}{2}$  single to 50 2ply cotton and 18 to 40 worsted yarns); 35 knitting machines; 20 sleeve machines; steam; sell direct; 256 Church St, Room 55, N. Y.
- Florence.** J-5. P. RR. Amboy Div.
- FLORENCE THREAD CO.**; \$50,000; W. (**C**) F. Thacher, pres; Newton Morton, treas; Frank W. Thacher, sec; W. C. Sturtevant, supt; Threads of all kinds (cotton) for manufacturers in Southern Carded, and Combed Peelers and Egyptians; steam; dye; sell direct, 210 Chestnut St., Phila., and 467 B'way, N. Y. (Wm. C. Starveant buys drugs and gen'l supplies; Frank W. Thacher buys yarns.)
- Garfield.** D-9. N. Y, L. E. & W. RR. Bergen County Br; N. Y. S. & W. RR. Passaic Br.
- GARFIELD WOOLEN CO.**; \$20,000; G. C. (**W**) Mercer, pres. and treas; Ellis Hey, vice-pres; David Dwyer, sec. and supt; Shoddy and Extracts; 10 sets; 7 pickers; 1 garnett; 4 carbonizers; steam; dye; sell direct; G. C. Mercer, buyer.
- Gloucester City.** L-4. A. C. RR. Gloucester Br; W. J. RR.
- ARGO MILLS CO.**; \$600,000; Henry S. Grove, (**C**) (Phila.) pres; Geo. W. Grove, treas; Geo. W. Turner, supt; Hosiery and Weaving Yarns; 14,000 ring and 22,000 mule spindles; steam; sell direct. Office, 216 Chestnut St., Phila.
- FRIES-HARLEY CO.**; \$200,000; Frederick (**W**) Fries, pres. and supt; Wm. J. Thompson, treas; Carpets and Rugs; 75 looms; electricity; dye; sell direct.
- GLOUCESTER COTTON MILLS CO.**; \$50,000; (**C**) Wm. P. Troth, Jr., pres; Jas. L. Wilson, treas; H. C. Powell, supt; Shirts, Gingham and Cotton Dress Goods; 10,940 ring and 2,560 mule spindles; 505 looms; steam; dye; James W. Cooke & Co, Phila. and N. Y., s. agts.
- GLOUCESTER MFG. CO.**; 125 Chestnut St; (**P**) Phila; \$150,000; G. A. Heyl, pres; Henry M. Rogers, treas; Henry M. Harley, gen. mgr; Printing Cotton Cloths; 12 printing machines; steam; dye; sell direct. Offices, Phila., N. Y., Chicago and Boston. E. S. Moore, buyer.
- Guttenberg.** D-9. Ferry from N. Y.
- LANDRU SILK MILL**; *Removed to Harer.* (**S**) *straw, N. Y.*
- Hackensack.** D-9. W. S. RR. Hudson River Div.



Map of  
**NEW JERSEY**

Showing the Textile Mill Towns,  
Specially engraved for the Textile World.

Scale 10 Miles to each square.

Copyright, 1895, by Guild & Lord, Boston.

THE MATTHEWS MAP CO. NEW YORK, N. Y.

- GIVERNAUD BROS**; Broad Silks; 550 (S) looms; N. Y. office, 71-73 Greene St., (Also at West Hoboken and Allentown, Pa.)
- Hackettstown**. D-5. D. L. & W. RR, Morris & Essex Div.
- ASHLEY & SHAW SILK CO**; \$50,000; John (S) Shaw, pres; Wm. H. Ashley, treas. and buyer; Thrown Silk; 12,000 spindles; steam; sell direct; Wm. H. Ashley, buyer. (Also Phillipsburg, N. J., and Avoca, Pa.)
- Haledon**. C-8. From Paterson.
- CEDAR CLIFF SILK CO**; (P. O. address, (S) Paterson); \$300,000; Ernest B. Rubsamem, pres. and treas.; Edward A. Spengeman, supt. and buyer; all kinds of Broad Silks; 4000 spindles; 300 looms; steam; sell direct; 722 Broadway, N. Y.
- COLUMBIA RIBBON CO**; John Grossge (S) bauer, pres; Hat Bands and Ribbons; steam; dye; office 13 Washington Place. (Purchased the Wm. Wicke Mill.)
- FULTON & SMITH**; (formerly W. & J. (S) Robertson); Upholster Goods, Dress Silks and Draperies; 125 looms; steam; sell direct.
- Hammonton**. N-5. A. C. RR; C. & N. RR.
- EVANS, JOS. P.**; Lakeside Mill; Welsh (W) Flannels; 6 looms; buy 14 and 15 wool; steam; dye; sell direct.
- HAMMONTON KNITTING CO**. *Out of business*
- Harrison**. E-9. (Branch Newark P. O.) From Newark.
- CLARK MILE-END SPOOL COTTON CO**; (C) Spool Cotton. See Newark.
- Hawthorne**. C-9. N. Y. L. E. & W. RR. Eastern Div; N. Y. S. & W. RR.
- AMERICAN SILK DYING & FIN (P, D & F) ISHING CO**; \$100,000; Wm. A. Arnold, pres; Thomas J. Arnold, sec. and treas; Geo. Arnold, vice-pres; Printed, Dyed and Finished Silks; steam; N. Y. office, 52 Howard St; T. J. Arnold, buyer.
- AMERICAN TEXTILE WATERPROOFING CO.** (D) N. Y. office, 55 Howard St.
- Hightstown**. H-7. P. and H. RR; Penn. RR.
- HIGHTSTOWN SMYRNA RUG CO**; \$50,000; (W) F. C. Moody, pres; J. Cooke, treas; Smyrna Rugs; 200 looms; steam; sell direct and through agts.
- Hillsdale**. C-9. Erie RR.
- BARNETT, S. L. & CO.**; Dress Silks; 100 (S) looms; G. Hosman, 477 Broome St., N. Y., s. agt. *Reported receiver appointed Apr., 1912.*
- ROSDIE FABRIC COMPANY**; 624 Clinton (S) St., Hoboken; \$30,000; Max Meyenberg, pres; Albert Kuen-tler, treas; Chas. Laubseh, supt; Silks of Light Weight and Texture; 40 looms; steam; sell direct.
- Hoboken**. E-9. Ferry from N. Y.
- AMSTERDAM SILK MILLS**; 1011-1015 Grand (K) St., (Branch of Amsterdam, N. Y.) Golf Gloves; 70 knitting machines; steam; sell direct; Louis Liechtenheim, buyer.
- BALAS, FRERES**; (Ltd.); 4th and Jefferson (S) Sts.; Ribbons; 80 looms; Poncelet & Neeser, 108 Greene St. N. Y., s. agts.
- BECK BROS**; Ferry and Bloomfield Sts; (S) Ribbons and Bindings; 30 looms.
- HOBOKEN SILK DYE WORKS**; Eugene (D) Schmidt, prop; 907 Madison St; Dye Orgazines, Trams, Souples, blacks and colors.
- KUHLEN, FRED**; 506 First St; Cardigan (K) Jackets, Sweaters and German Cardigan Jackets a specialty; 4 knitting machines; sell direct. (Buy 48 to 308 worsted yarn.)
- MAJESTIC VELVET MILLS**; 618-622 Clinton (S) St; \$50,000; Max Meyenberg, pres. and supt; Silk Velvets; 40 looms; gas; Abergg & Rusch, N. Y., s. agts.; Max Meyenberg, buyer. (Buy single 26, 30, 34, 36, 40, 45, 50 combed Egyptian.)
- WRIGHT'S HEALTH UNDERWEAR CO**; (K) 628 Clinton St; W. D. Wright, mgr; Fleece-lined and Ribbed Underwear for Men, Ladies and Children; 20 Knitting and 100 Sewing machines; steam; sell direct, 75 Franklin St., N. Y.; W. D. Wright, buyer. (Also at Troy, N. Y. and Powiall, Vt.)
- Hohokus**. C-9. N. Y. L. E. & W. RR, Eastern Div.
- BROOKDALE BLEACHERY**; \$100,000; (B) Philip P. Tyre, pres; John L. Vansant, treas; Bleaching and Finishing Cotton Piece Goods; Clay filled goods a specialty; steam and water.
- Homestead**. E-9. N. Y. L. E. & W. RR.
- GIVERNAUD BROS.** Branch mill. See West (S) Hoboken.
- Jamesburg**. G-7. (Not shown on map.) Pa. RR.
- WESTERHOFF BROS. & NAHER CO**; \$10,000; (S) P. D. Westerhoff, pres, and agt.; H. Westerhoff, treas.; Broad Silks; 75 looms; sell direct. (See also Paterson, N. J., and Denver and Ephrata, Pa.)
- Jersey City**. E-9. Ferry from N. Y.
- CHADWICK, JAS. & BRO (LTD.)**; mill at (C) Greenville; M. Grierson, agt; E. Bridge, supt; Spool Cotton and Fine Cotton Yarns; 30,000 mule and 10,000 ring spindles; steam; sell direct.
- DONOHUE, M. W.**; 452 W. Side Ave; (K) Knit Goods, Drawers, Leggings, Infants' Eiderdown Sacks, etc; 10 knitting machines; 3 crocheting machines; 3 sewing machines; sell direct.
- EURKA FIRE HOSE CO**; Wilkinson and (C) Arlington Aves; \$500,000; M. L. Reed, pres; Geo. A. Wies, treas; Nathan Stowe, supt; Hydraulic Hose and Tubular and Flat Fabrics; 1400 spindles; 80 looms; steam; Geo. A. Wies, 13 Barclay St., N. Y., s. agt; B. L. Stowe, buyer and vice pres.
- HALL, HARRIET S**; 48-56 Saydam Ave; (S) Thos. J. Hall, supt; Gloves, Mitts, Laces, Velling, Etc; steam; salesroom, 467 Broadway, N. Y. City. (Buy 2/20 to 2/100 Mercerized yarns, Plain cotton yarns, 2/180 and 2/200; Spun Silk yarn, 2/25, 2/30; Raw Italian and Japan and 2 and 3 thread Organzine and Tram.)
- KEUTEL, JULIUS**, formerly Frederic (S) Kraemer; 138 Griffith St; Cords, Fringes, Ornaments, Etc; (buys Cotton, Linen and silk Yarns); 8 looms; gas; sell direct. (Mill at Jersey City Heights.)
- LUDWIG MFG. CO**; 104 Cambridge Ave; (S) H. C. Ludwig, pres. and supt; Geo. A. Foye, treas.; Fringes, Tassels, etc.; 7 power and 1 hand loom; Hubbard, Smith & Co., Chicago, s. agts.
- MOREL, EMIL**; 191 Webster Ave; Silk (D) Dyeing.
- N. J. HAT WORKS**; 313 3rd St; S. Wacht, (W) agt; D. Fuchs, supt; Wool and Fur Hats; steam; dye; sell direct; S. Wacht, buyer.
- NUFER, E.**; 100 Hague St.; Jersey City (S) Heights; Fine Swiss Embroideries; 4 embroidery machines.
- PAYONIA KNITTING MILLS**; H. A. Gould; (K) (successor to E. A. O'Callaghan); Payonia and Chestnut Aves; Sweaters, Golf Hose, Children's Legging Drawers; 10 knitting machines; electric power; sell direct.
- PHALANX SILK MILL**; 109 Irving St; J. (S) Hohl, supt; Broad silks; 300 looms; steam; Passavant & Co., N. Y., s. agts.
- SCHAEFER, L. B.**; 194-196 Central Ave; Silk, (S) Chenille, Arrasene and Linen Fringes, Cords, Tassels, Plush Balls, Etc.; 52 looms; steam; sell direct.
- SCHILLER, PAUL**; 209-213 Linden Ave; (C) Elastic Suspender Webbing; 10 looms; steam; dye; sell direct. (Buy 40/2, 16/2, 20/2 warp twist Peeler; 21/3 Ply Soft; 40/2 ply Sea Island Mercerized yarn.)

- STOHN & MINCKE; 162-164 Congress St. (S Jersey City Heights; Silk Vestings for Shoe and Tailoring Trade; 24 looms; steam; A. Mincke, buyer.
- STOHN'S C. SONS; (Inc.); \$250,000; Emil (S Stohn, pres.; Gustave Stohn, treas. and agt.; Paul F. Stohn supt.; Stohn's Vestings for Shoe-tops and Vests; Button Stock, Dress Goods and Tie Silks; 250 looms; steam; dye; sell direct; Emil Stohn, buyer. (Buy 30/2 to 140/2 cotton warp.)
- SUFERMANN, ABRAHAM; 66 Hancock (D & F Ave; Cotton and Silk dyer and finisher.
- ZIMMERMAN, THE CHN. & SON CO. (of (K Apolda, Germany); 48-52 Thiers Ave; John Schmidt, pres.; Alfred Schmidt, treas.; A. Sonderhof, supt.; Plain and Fancy Knit Goods; steam; sell direct; 377 Broadway, N. Y.
- Keypport.** G-S. Cent. R. R. of N. J.
- CURRIE THREAD CO; Thread; steam; sell (C direct. (Buy yarns.)
- Lake View.** D-9. N. Y. L. E. & W. RR, Eastern Div. See Paterson.
- Little Falls.** D-S. D. L. & W. RR, Boonton Br; N. Y. & G. L. RRs.
- BEATTIE MFG. CO; 85 White St, N. (W Y; \$300,000; Robt. Beattie, pres.; Wm. Beattie, treas. and supt.; Tapestry and Velvet Carpets, Lap Robes and Felt Goods; 17 sets; 1,728 worsted spindles; 3 combs; 96 looms; water; dye; Robert Beattie Sons, 133 5th Ave. N. Y. s. agts.
- GLOBE DYE WORKS; Cotton Skein (D & D Bleaching and Dyeing; steam.
- JACKSON, JAS., & SONS. Also at (D & F Paterson.
- SHUTT, GEORGE, DYE WORKS; (Works (D & F at Cedar Grove, N. J.); Dyer and Finisher of Velvets, Velvetene and Corduroys.
- SINDLE, S; Hair and Wool Felt; 2 sets; (W steam and water; sell direct.
- Lodi.** D-9. Lodi RR.
- ALEXANDER DYE WORKS; \$50-. (D, F & Pr 000; Fred Blum, pres; Chas. Blum, treas; Albert Blum, sec; Henry L. Blum, supt; Silk and Silk Mixed Piece Goods; steam; dye; Fred and H. L. Blum, buyers.
- BOETTGER-PIECE DYE WORKS; (D, D & F \$100,000; H. W. Boettger, pres; T. M. Boettger, treas. and supt.; Bleachers, Dyers and Finishers Silk and Cotton and Silk Mixed Fabrics; steam; Boettger & Hinze, 500 Broome St., N. Y., sole agts.
- BONITZ, HERMAN, Co; \$75,000; N. Bonitz, (W pres; H. Bonitz, treas; Shoddy and Extracts, dealers in Botany Waste; 6 pickers; 16 cards; steam; dye; Wm. Lancaster, supt; H. Bonitz, buyer; sell direct.
- LODI DYE WORKS. See Passaic.
- Malaga.** N-4. W. J. RR.
- KNIGHT & SHEA MFG. CO.; J. W. Shea, (C pres. and supt.; A. E. Knight, treas.; Fancy Toweling; 37 looms; steam; Jos. S. Whiteside, 47 Leonard St., N. Y.; J. W. Shea, buyer.
- May's Landing.** O-6. West Jersey & Sea Shore RR.
- MAY'S LANDING WATER POWER CO. (P. O. (C address, 626 Chestnut St., Phila.); \$250,000; Geo. Wood, pres.; Edward Lippincott, treas.; Linings, Towellings, etc.; 11 500 ring and 8,000 mule spindles; 500 looms; water and steam; Kremer & Strubing, 626 Chestnut St., Phila., s. agts.
- Midland Park.** C-9. N. Y. S. & W. RR.
- DE GRAY & Co; Dress and Tie Silks; 150 (S spindles; 30 broad looms; water; sell direct; W. De Gray, buyer.
- HOLT SILK CO, THE; \$30,000; Thos. (S Holt, pres. and supt.; Tie Silks; 46 looms; steam; Plant & Lucas, 131 Spring St., N. Y., s. agts.; Thos. Holt, buyer. (Buy 80/2 warp twist, 40/2 warp twist, 60/2 soft twist.)
- MORROW'S, G, SONS, \$15,000; Blankets, (W Felt Cloths and Yarns; 2 sets; 5 looms; water; dye; sell direct.
- Millville.** O-4. W. J. RR.
- MILLVILLE MFG. CO; Manantico (C, D & D Bleach and Dye Works; \$450,000; Geo. Wood, pres. and treas.; Plain and Fancy Twills, Sateens, etc.; Bleachers and Dyers of Cottons; 36,000 ring and 10,000 mule spindles; 1,000 looms; steam and water; Kremer & Strubing, Phila., N. Y. and Chicago, s. agts.; Kremer & Strubing, 626 Chestnut St., Phila., buyers for bleach and dye works.
- Montville.** D-7. D. L. & A. RR, Boonton Br.
- CAPSTICK, JOHN, & SONS; Dye, (Pr D & F Bleach and Print; 14 printing machines; steam and water.
- Mount Holly.** K-5. P. RR, Burlington Br; Camden & Burlington County RR, Medford Br.
- STANDARD HICKS HAMMOCK CO; \$75,000; (C John A. Bidwell, pres; T. W. Borton, treas; John A. Bidwell, supt; Hammocks, Towels, Table Felt and Textile Novelties; 40 looms; steam; sell direct; 71 Franklin St., N. Y., 116 Pearl St., Boston; J. A. Bidwell, buyer.
- SYKES, A. & Co.; Rag Carpets and (W Smyrna Rugs; 10 looms; J. Sykes, buyer. (Buy 8/2, 8/3, s/4 Cotton yarn, Wool Rug and Fringe, Listings and Carpet Rags.)
- Newark.** E-9. P. RR, N. Y. Div; N. Y. L. E. & W. RR, Newark Br; C. RR, of N. J.; Newark & Elizabeth RR, Newark & N. Y. Br; D. L. & W. RR.
- BASCH & GREENFIELD CO; 28 to 46 Summer (W Ave; \$50,000; M. H. Baumgarten, pres; C. J. Basch, treas; Shoddy and Flocks; 20 cards; 8 pickers; 9 flock cutters; steam; dye; sell direct; Chas. J. Basch, buyer.
- CARL PAAS COMPANY, The; \$20,000; (C & S 8-14 Lum St. (rear 251 N. J. RR. Ave.); Hughes Fawcett, pres.; John Cathcart, sec. and treas.; Cotton and Silk Shoe Laces.
- CLARK MILE-END SPOOL COTTON CO; (C \$2,000,000; Spool Cotton and Yarns; 35,000 spindles; steam; dye; The Spool Cotton Co., 80 & 82 White St., N. Y., sole agts. U. S.
- CLARK THREAD CO, THE; Clark and Og- (C den Sts; \$750,000; J. Wm. Clark, treas; O. N. T. Spool Cotton; 10,000 ring & a 175,000 mule spindles; steam; dye; The Spool Cotton Co., N. Y., sole agts. U. S.
- GROSSGEBAUER, JOHN, MFG. CO. See Columbia Ribbon Co., Haledon, N. J.
- LINDNER, HUGO; 597 So 17th st; Golf (K Hose and Jackets; Fancy Half Hose and Sporting Sweaters; 6 knitting machines; J. Weingart, N. Y. and T. H. Campbell, Chicago, s. agts.
- NEW JERSEY WICK COMPANY; Cor. (C Montclair RR, and Mt. Prospect Aves; \$108,000; E. G. Heller, pres; P. E. Heller, treas; James Tynan, supt.; Manufacturers of "Marshall Process" and "Hydro-Carbon" Wicks, etc.; electric; sell direct and Plume & Atwood Mfg. Co., N. Y. and Chicago, s. agts.; R. A. Heller, buyer. (Buy soft yarns in skeins from 11/2/2 ply yarn to 6/2, also 50/3 and 40/3 peeler yarn.)
- ROSSENDALE-REDDAWAY BELTING & HOSE (C CO, THE; Euclid Ave; \$150,000; Frank Reddaway, pres; Wm. M. Clarke, treas; "Camel" brand Hair Belting, Stitched Cotton Belting, Cotton and Linen Fire Hose; 50 looms; steam; sell direct.
- SURESBURY MILLS; Marshall & Co; (P. (F1 O. Box 256; \$500,000; Wm. Barbour, pres; R. B. Symington, treas; J. S. Coey, supt; Linen Thread, Yarns and Twine; 10,900 flax



- spindles; steam; dye; The Linen Thread Co., N. Y., s. agts.; J. S. Coey, buyer. Mill at Kearney.
- STEIN, SAMUEL P.**: 274 So. 9th St.; Heavy (K) Woolen Stockings.
- New Brunswick.** G-7. P. RR, N. Y. Div.
- JOHNSON & JOHNSON**: \$250,000; R. W. (C & K) Johnson, pres.; J. W. Johnson, treas. and sec.; Wm. H. Ritter, supt. and buyer; Absorbent Cotton, Lint and Surgical Supplies; 16,000 ring spindles; 440 looms; bleach and finish; steam; sell direct.
- KILBOURN KNITTING MACHING Co.** See *Mid-dlesex Knitting Co.*
- MARCH, ALFRED, & Co.**, 154 Hamilton (K) St.; Children's Ribbed Full Fashioned Underwear, Abdominal Bands and Corset Covers; 18 knitting machines; 16 sewing machines; steam; Spielmann & Co., N. Y., s. agts.; Alfred March, buyer. (Buy worsted, 1/28, 1/36, 1/40 and cotton, 1/40, 1/60 and silk yarns 2/15 and 2/25.)
- MIDDLESEX KNITTING CO.**: \$100,000; E. E. (K) Kilbourn, pres.; C. W. Kilbourn, treas.; Hosiery factory, Martinsburg, West Va., which see.
- NORFOLK & NEW BRUNSWICK HOSIERY (K) Co.**: 519 Broadway, N. Y.; \$550,000; J. N. Carpenter, pres.; Nicholas G. Rutgers, treas.; Chas. E. Spencer, supt.; Full Fashioned Underwear and Hosiery, also Flat and Ribbed Goods; 26 sets; 400 knitting machines; 120 sewing machines; steam and water; dye; A. D. Juilliard & Co., 70 North St., N. Y., s. agts. (Buy cotton and worsted yarns, various sizes.) Also mill at Norfolk, Ct.
- ROBINSON, FRED'K.**, 21 Robinson St.; Plain (K) and Ribbed Hosiery, Cardigan Jackets, Knit Sporting Goods, Gloves, Bicycle Hose, Leggings, Caps, etc.; 21 knitting machines; hand power; sell direct; F. G. Robinson, buyer. (Buy worsted 2/27, 3/23 3/16, 2/20, 3/18 extra quality and wool yarns, medium, 2/14, 3/20, 2/20.)
- Newfield.** N-4. West Jersey RR.
- NEWFIELD SMYRNA RUG Co.**: \$100,000; (W) John O'Neill, mgr.; Smyrna Carpets and Rugs; 78 looms; 2 sewing machines; steam; dye; sell direct. (Buy 8/3 and 30/2 yarn.)
- Newton.** C-6. D. L. & W. RR.
- VALENTINE & BENTLEY SILK CO.**: \$50,000; (S) David Valentine, pres.; Thos. W. Bentley, treas. and agt.; Broad Silks; 500 looms; steam; dye; Spielmann & Co., 83 to 87 Grand St., N. Y., s. agts.; Thos. W. Bentley, buyer. Also Watertown, N. Y., Pittston, Pa.
- Nordhoff.** D-10. N. RR. of N. J.
- BARRETT'S, PALMER & HEAL**; Dyers (D & F) and Finishers; steam; N. Y. office, 346 Canal St.
- Nutley.** D-9. N. Y. L. E. & W. RR, Newark Br.
- LOBSTZ, SAMUEL**; Wool and Silks; Card (W) ing & Garning; and Fur Blowing; 15 cards; 11 garnetts; 8 fur blowers; steam; sell direct; 260 Church St., N. Y.
- PEARSON, J. W. CO.**: (Nutley Mills); Plushes (S) and Velvets; dye; sell direct.
- Orange Valley.** E-8. RR. station W. Orange, Erie RR.
- TRIMBLE CLESS HAT Co.**: \$30,000; Jo. (W) seph A. Volk, pres.; W. E. Cless, supt.; S. J. Shaw, supt.; Soft Fur Felt Hats; Volk Hat Co., So. Norwalk, Conn., s. agts.
- Passaic.** D-9. D. L. & W. RR, Boonton Br.; N. Y. L. E. & W. RR, Eastern Div.; N. Y., S. & W. RR, Passaic Br.
- ALEXANDER SILK MILLS**: Passaic and (S) Canal St.; Alexander C. Huber, supt.; Silk Vestings and White Figured Goods, Mohair Serges and Tie Silks; 126 looms; water; John J. Ruegg, buyer. (Buy yarn.)
- ALGONQUIN CO, TIE**; \$300,000; Wm. (W) Barbour, pres.; E. Le B. Gardiner, vice-pres; Winthrop Cowdin, treas.; M. P. Slade, sec.; Woolen Goods; 8 sets; 122 looms; also 3 shoddy cards; steam and water; dye; sell direct; E. Le B. Gardiner, M. P. Slade, buyers.
- BOTANY WORSTED MILLS**: \$2,500,000; (W) Dress Goods and Worsted Yarns (dry spun); 80 combs; 65,000 worsted spindles; 1800 looms; steam; dye; sell direct.
- BRIGHTON MILLS**: \$250,000; William Lyall, (C) pres.; William L. Lyall, treas.; Wm. O. Smith, supt.; Crochet Quilts, Special Fabrics and Combed Sea Island Cotton Yarns, 18s to 30s, any ply; 2,500 ring spindles; 107 looms; steam; sell direct. (Buy common Southern 8/2 to E/3 various ply; combed and carded Egyptian, 18/2 to 30/2 various ply; Combed Sea Island 18/2 to 34/2.) (Removed plant from New York City.)
- CLARENDON WOOLEN CO.**; First and (W) South Sts., J. J. Baumgarten, pres.; M. H. Baumgarten, sec. and treas.; Serge Linings.
- DUNDEE TEXTILE Co.** Proposed. (W)
- DUNDEE WOOLEN CO.**: \$56,000; W. T. Al- (W) drich, pres.; Fred Lowe, treas.; W. G. Ratcliffe, supt.; Fancy Cassimeres; 6 sets; 42 looms; steam and water; dye; Converse, Stanton & Co., N. Y., s. agts.; Fred Lowe, buyer.
- GERA MILLS**; Ernest Fr. Weissflog, (W) prop.; C. Bahnsen, mgr.; Woolen and Worsted Dress Goods; 500 looms; steam; dye; (office 450-452 Broome St., N. Y.)
- LODI DRY DYEING CO.**; (successors to (D) Lodi Dry Dye Works.) \$200,000; Sam'l Briggs, pres.; Ed. Freedman, treas.; E. Rau, supt.; Dyeing, Re-dyeing and Finishing Silks, Satins, Velvets, etc.; steam; J. Rau, buyer.
- MANHATTAN PRINT WORKS**; (Pr & D) Worthen & Aldrich Co. (also at Dela-wanna); Wm. P. Aldrich, treas.; Peter Fitzpatrick, supt.; Woolen, Silk and Velvet Goods, Printers and Dyers; 15 machines; steam; N. Y. office, 25 No. Moore St.; F. E. Aldrich, buyer.
- McLEAN, A. CO.**; Passaic Mills; (C) \$1,000,000; Andrew McLean, pres.; W. Mal-colum, treas.; Mosquito Nettings, Linings, Cotton Fabrics, Etc; 184 looms; steam; dye; bleach; sell direct; N. Y. office, 460 Broome St. (Buy fine cotton yarns).
- OKONITE CO., Ltd**; \$1,700,000; Wm. L. (C) Candee and H. Durant Cheever, mgrs.; Insulated Wires and Cables; 300 braiders; steam; N. Y. office, 253 Broadway.
- PASSAIC PRINT WORKS**; \$500,000; (Pr & D) Peter Reid, pres.; Edward E. Poor, Jr., treas.; Chas. B. Kendall, supt.; Printed and Dyed Fabrics; 13 printing machines; steam; Poor Bros., 19 and 21 Thomas St., agts.; N. Y. James L. Bull, asst. treas., buyer.
- PASSAIC WOOLEN CO.**; Henry L. Basch, (W) treas. and agt.; H. E. Sykes, supt.; Men's and Women's Woolens; 7 sets; 35 looms; steam and water; dye; Stevens, Sanford & Handy, N. Y., s. agts.; Henry L. Basch, buyer.
- PASSAIC WORSTED MILLS TIE**; Pitkin, (W) Holdsworth Worsted Co; \$200,000; F. E. Pitkin, pres.; John W. Pitkin, treas.; Jos. Holdsworth, mgr. and buyer; Worsted Yarns (English system); 8 sets; 8 combs; 7,800 spindles; steam; sell direct. (Also see Manhattan Worsted Mills, New York City).
- REID & BARRY WORKS**; (U. S. (Pr, D & F) Finishing Co., N. Y.) Jas. Bryce, resident mgr.; Finishers of Cotton Goods; steam and water; dye. (See New York City for officers and machinery.)

ROBERTSFORD WORSTED MILLS; Sam. (W) nel Hird, prop.; Fred Carter, supt.; Serges Clay Worsteds and Worsted Yarns; 4 sets; 3 combs; 72 broad looms; 1872 spindles; steam; dye; Jas. Stern & Co., N. Y., s. agts.

**PATERSON, D.9.** D. L. & W. RR, Boonton Br; N. Y., L. E. & W. RR, Eastern Div, Newark Br; N. Y., S. & W. RR.

ACKERMAN, H. K.; 394 E. 21st St.; L. W. (S) Ackerman, supt.; Throwing; Tussah Throwster; 1,000 spindles; steam.

AMERICAN BRAID CO.; Cooke Works; (W & S) Market and Jersey Sts.; \$5,000; James Barr, pres. and supt.; John Mathews, treas.; Silk and Mohair Braids; 800 machines; steam; H. A. Caesar & Co., N. Y., s. agts.

AMERICAN SHAWL CO.; Addy Mill; 93 (W) River St.; J. L. Kaufman, treas.; H. Kaufman, supt.; Worsted Shawls; 6 broad looms; sell direct.

ANDERSON BROS.; Barnert Mill; Dress (S) Goods, Tie Silks, Crepe de Chine, Handkerchiefs, Scarfs, Etc; 150 looms; H. A. Caesar & Co., N. Y., s. agts.; John H. Anderson, buyer.

APPEL BROS. MFG. CO.; Hamilton Mill; (S) \$50,000; Jos. Appel, pres.; Chas. S. Eckstone, sec. and treas.; Jos. Appel, agt.; Tie Silks; 100 looms; steam and water; I. S. Wolf, s. agt.

ARMITT, JAMES & SON; 127 East 20th St., (S) Ribbons; 6 looms; sell direct.

ARONSON & BLOOM; McAlister Mill (S) (formerly Commercial Silk Mfg. Co.); Broad Silks; 8 looms.

ARONSON, SAM'L J.; Granite Mill; (for- (S) merly Murphy & Aronson); Tie and Dress Silks; 122 looms; steam; Elmer & Naylor and Doull, Miller & Co., s. agts.

ASHLEY & BAILEY CO, THE; (also Colum- (S) bia, Coatsville, York and Marietta, Pa, and Fayetteville, N. C.) River St. & Erie RR; Dwight Ashley, pres.; Peter Bailey, treas.; Dixon Bonstead, supt.; Mullers, Handkerchiefs, Dress Silk, The Silk and Ribbons; 10,000 spindles; 1500 looms; steam; dye; sell direct; N.Y. office, 109 and 111 Spring St.; J. J. Bailey, buyer.

AUDIGER & MEYER SILK CO.; \$100,000; (S) Julius Meyer, pres.; R. Trompeter, treas.; Edward Doerken, supt.; High Grade Tie Silks; 126 looms; electricity; Passavant & Co., N. Y., s. agts.; Edward Doerken, buyer. (Buy combed Egyptian and Sea Island cotton 40/2-120/2.) (Mill at South Paterson, Marshall & South Dakota Sts.)

AUGER & SIMON SILK DYEING CO. (D & F) (P. O. Box 1878.) Riverside; \$100,000; Chas. L. Auger, pres. and treas.; Silk Skein Dyeing; steam; C. L. Auger, buyer.

AUGUSTA SILK WORKS; 3234 Lawrence (S) St.; \$100,000; Ralph Rosenheim, pres. and supt.; Ribbons; 90 looms; steam; L. Erstein & Bro, N. Y., s. agts.

BAGDAD RUG CO.; 1 loom. (Not doing (W) any business, experimental only.)

BAKER & SCHOFIELD CO.; Todd Mill; (S) \$25,000; Geo. B. Baker, pres.; James Schofield, treas.; Broad Silks; 122 looms; steam; Oelbermann, Dommerich & Co., N. Y., s. agts. (Also 60 looms in Waverly mill.)

BALL, WM.; Sumner and Montgomery (S) St.; Broad Goods and Ribbons; 24 broad looms; 30 ribbon looms; L. Erstein & Bro, N. Y., s. agts.

BAMFORD BROS. SILK MFG. CO.; (Hale- (S) don); \$900,000; Jos. Bamford, Sr. pres.; Jos. Bamford, Jr. sec.; Walter Bamford, treas.; Silk Ribbons; 500 looms; steam and dye; Abegg & Rusch, N. Y., s. agts. (Also Belvidere and Wilkesbarre, Pa.)

BANNER SILK CO.; A. Bannigan, prop.; (S) New Barnert Mill; Broad Silks and Novelties; 58 looms; sell direct and Oelbermann, Dommerich & Co., N. Y., s. agts.

BARBOUR FLAX SPINNING CO.; (F1, J & D) Grand St., near Prince; \$750,000; J. E. Barbour, pres.; William Barbour, treas.; Linen Threads, Nets and Yarns; steam and water; dye and bleach; also for the trade; The Linen Thread Co., 48 White St., N. Y., s. agts.

BARCLAY SILK CO. See Clifton, N. J. (S)

BEAVER VELVET CO. (In New Hall Mill); (S) \$50,000; John Hollbach, pres; Will Stock, treas.; Silk Velvets; 25 looms; steam; Fleitmann & Co, N. Y., s. agts.

BECKETT, DAVID, SILK CO.; Hall Mill; (S) \$100,000; Fulton St.; D. Becket, agt.; Ribbons; 25 looms; steam; H. A. Caesar & Co., N. Y., s. agts.

BENTLEY BROS.; New Barnett Mill; (S) Broad and Tie Silks; 104 looms; Spielmann & Co., s. agts.

BIRDGREENWAY, J. M.; Hamilton Mill; (S) Silk Ribbons; 4 looms; steam and water; sell direct.

BOEHN & BRAUCH; Harding Mill; Broad (S) Silks; 85 looms.

BOLTON BROS. SILK DYEING CO.; East (D) 11th St.; \$50,000; J. H. Bolton, pres. and treas.; J. R. Bolton, supt.; Commission Dyers; J. H. & J. R. Bolton, buyers.

BRANDES, JULIUS, MFG. CO.; Marshall. (S) cor. Dakota St.; \$225,000; Julius Brandes, pres.; A. J. Rolfe, treas; Ribbons, Bindings, etc.; electric; dye; sell direct; pres. and treas., buyers.

BRILLIANT SILK CO.; J. B. Whitney, (S) prop.; Grant Works; Wm. Eaton, supt.; Silk Linings and Dress Silks; 144 looms; water; Abegg & Rusch, 90-94 Grand St., N. Y., s. agts; J. B. Whitney, buyer.

BRISTOW, MCCOLLUM & POST; Patterson (S) and Harrison Sts.; Broad Silks; 60 looms; electricity; S. J. Hall 487 Broadway, N. Y., s. agt.

BROWN, H. H. & SONS; 159-161 Marshall (D) St.; Cotton Yarn Dyers; steam.

BUFFALO SILK MFG. CO.; S. Isaac, prop.; (S) 56-60 Buffalo Ave.; Taffetas; 16 looms; gas engine.

BURLINGTON SILK CO.; Murray Mill; (S) Mill St.; Adam Shearer, mgr.; Broad Silks; 34 looms; electricity; sell direct.

BUTZ, SIEGFRIED; Harmony Mill; Dress (S) and Tie Silks; 26 looms.

CAMERON & KRUG; (Haledon) Haledon (Pr) Ave.; Silk Printers; steam.

CARDINAL & BECKER; Walder Mill; 26 (S) and 28 Fulton St.; Broad Silks, Dress Silks, Plain and Fancy Lining Silks; 140 looms; steam; Schefer, Schramm & Vogel, N. Y., s. agts.

CARDINAL SILK CO.; Lakeview; \$55,000; (S) A. Cardinal, pres.; Hugo Von Reitzenstein, treas; Frederick Tieding, supt.; Dress Silks, Trimmings and Linings; 2,100 spindles; 133 looms; steam; Siegmund, Douglas & Co, N. Y., s. agts; A. Cardinal, buyer. (Buy yarns.)

CASPERS SILK CO.; \$25,000; Leonard (S) Schrepfer, pres. and treas; August A. Fischer, agt. and supt.; Silks Veilings; 220 looms; steam; sell direct; August A. Fischer, buyer.

CEDAR CLIFF SILK CO. (See Haledon.) (S)

CENTRAL SILK FINISHING CO.; 117-23 (F) River St.; \$6000; Jos. Depret, pres; Z. Hameefman, treas.; S. Hameefman, supt. and buyer; Finishers of Broad Silks; steam.

- CENTURY THROWING Co; Industry Mill; (S) Peter R. Rowson, pres.; Alexander Mc Lane, treas.; Chas F. Isleib, vice-pres and supt; Silk Throwsters on Commission; 13,000 spindles.
- CLARKE, THOS; Rear 360 Main St; (D & F) Ribbons, Skein Silk Dyeing and Finishing; steam.
- CLIFFE, ARTHUR; 94 Sheridan Ave; Braids (S) and Narrow Bindings; 10 looms; steam; sell direct.
- CLOWES, SOTHERN Co; \$50,000; Addy Mill; (S) Ryle Ave; Broad and Tie Silks, Brocades, Etc; 110 looms; steam; sell direct; 23 Greene St, N. Y.
- COHEN BROS; 162 Ward St; Fulton Mill; (S) A. Atkinson, supt; Broad Silks; 86 looms; steam; sell direct; I. Cohen, buyer.
- COLE, ZACH; Hamilton Mill; Throwster. (S) *Mill not running.*
- COLLINGE & NOLAN Co.; Todd Mill; \$100,000; (S) 000; Edward J. Nolan, pres; Caroline Nolan, treas; Ribbons and Novelties; 63 looms; steam and water; Olbermann, Dommerich & Co., N. Y., s. agts.
- CONSUMERS SILK Co.; 35-37 Fair St.; (S) \$10,000; Ida Frisch, pres. and treas.; John Miller, agt.; Jacob Frisch, mgr. and supt.; Broad Silks in Variety; 15 looms; motor.
- CORNFORTH & MARX; Royle Mill; \$60,000; (S) W. H. Cornforth, pres; Albert Marx, treas; Broad Silks of all descriptions; 150 looms; steam; sell direct.
- CORONET SILK MFG. Co.; Hamil Mill; (S) \$50,000; Wm. J. Orr, pres. and supt.; Wm. W. Uhlinger, treas.; Silk Ribbons; 60 looms; steam and water; sell direct. (To make piece goods later.)
- CRAMER & KING Co; Market (Pr D & F) St; \$125,000; Arthur E. Cramer, pres.; Omer Cramer, treas.; Silk Printers, Piece Dyers and Finishers; steam; dye.
- CREW'S SILK FINISHING & PIECE (D & F) DYE WORKS; Alfred Crew, prop; Beach and Morton Sts; Finishers and Refinishers of Gros Grains, Brocades, Millinery and Umbrella Silks, Serges, Satins, Veilings, Etc; steam; dye; N. Y. office, 467 B'way.
- DAY, F. J. & Co; Essex Mills; Mill St; (S) Silk Ribbons; 5 looms; water; L. Erstein & Bro, N. Y., s. agts.
- DEXTER, LAMBERT & Co; 478 Straight St; (S) Ribbons, Dress Goods and Trimmings; steam; dye; N. Y. office, 35 Greene St. (Also see Hawley and Honesdale, Pa.)
- DIME, JACOB; Waverly Mill; Throwster; (S) 4000 spindles; water.
- DICK, CHRISTIAN. *See Riverside, N. J.*
- DOHERTY & WADSWORTH Co; Beech and (S) Essex Sts; \$500,000; Joseph Wadsworth, pres. and treas.; Dress, Tie and Millinery Silks; 700 looms; steam; S. Peierls & Co.; 10 and 12 Greene St., N. Y., s. agts.; Jos. Wadsworth, buyer.
- DOLFIN JUTE MILLS; Spruce St; \$500,000; (J) J. Herbert Johnston, pres; Pierre Maffi, vice-pres; S. S. Evans, Jr, sec. and treas.; R. B. Gordon, supt; Jute Yarns, Twine etc; 8000 spindles; steam; dye; sell direct
- DONAHUE DYEING Co; Hamburg Ave; (D) \$25,000; Velvets, Velveteens and Corduroys.
- DONAHUE, JOHN, & SONS; Market cor. (W) Main St; Carpet Weavers; 1 hand loom.
- DORDONI SILK DYEING Co; 16-22 Bridge (D) St; \$25,000; C. Dordoni, pres. and treas.; Silk Skein Dyeing in Black and Colors
- DUTTON, JAS; Essex Mill; Mill St; (S) Throwsters; 1600 spindles; water.
- EAGLE PRINTING Co; Schweizer & (Pr G) Gell; Haledon Ave. and Zabriskie St.
- ELSTON Wm. J; 159 Ryerson Ave; Silk (S) Warping and Winding; 5 warping frames; 2 winders.
- EMPIRE SILK Co; Fulton St; \$600,000; (S) O. Andrae, Jr, pres; A. Hill, vice-pres; F. Hill, treas.; Dress and Tie Silks; 420 looms; steam; Wm. Schroeder & Co., N. Y., s. agts.; A. Hill, buyer. (Also Cardon Dale, Pa.)
- ENTERPRISE SILK Co; Market and Spruce (S) St; \$65,000; A. Openhym, pres; Albert Stern, treas; T. T. Robinson, supt; Silks and Veilings; 400 looms; water; Wm. Openhym & Sons, N. Y., s. agts. (Also Reynoldsville, Pa.)
- ESSEX SILK Co; Essex Mill; John (S) Hotham, supt.; Broad Silks; 51 looms; J. I. Bruyn, N. Y., s. agt.
- FAIRHURST & Co; 535 and 537 East 18th (S) St; Broad and Tie Silks, Handkerchiefs, Etc; 56 fancy looms; electric; sell direct.
- FLEPPI, DOMENICO; 66 Sixteenth Ave; (Pr) Silk Skein Printing; all sizes from 45 inch skeins to 800 inch skeins; Ribbons; 16 machines.
- FOGLE & KILLIN; 200-202 Straight St; (S) Silks of all kinds; 265 looms; steam; sell direct; 89 Grand St, N. Y.; J. A. Kame, buyer.
- FORMANNS, STUMPF & SHARPE; Industry (D) Mills; Van Houten St; Skein Silk Dyers, in Colors and Black.
- FRANK & DUGAN; Cooke Mill and Dale (S) Mill; A. Hoffman and F. Benz, supts.; Ribbons; 222 looms; steam; sell direct; Joseph Frank, buyer.
- FROST & VAN RIPER; (Part of Plant re. (S) moved here), Silk Throwing. (Also Pittston, Pa.)
- FROST, CHARLES E.; Ball Mill; Mill St.; (S) Samuel De Mooy, supt.; Commission Throwster; 1800 spindles; steam.
- FUCHS SILK Co.; Essex Mill; 8 looms; (S) sell direct.
- FULTON, D. & Co; 306 River St; Wool (W) Pullers.
- GAEDE, ROBT; Hamburg Ave.; Skein (D) Silk Dyeing.
- GAUTSCHY SILK DYEING Co, THE; 61-67 (D) First Ave., Riverside; \$5,000; Henry Gautschy, pres; Skein Silk Dyers. (Formerly the West End Silk Dyeing Works, at New York City.)
- GEERING, EMIL; Valley of the Rocks (D) Dye Works for Blacks; Ryle Ave, and Market and Jersey Sts; Silk Skein Dyeing for Colors.
- GELDERMAN, F. H.; Progress Mill; \$2000; (S) Embroidery, Chenille, Dress and Millinery Trimmings; steam; sell direct.
- GENEVIEVE NOVELTY Co.; 26 Fair St.; (S) Silk Trimmings and Novelties.
- GOLDIE, THOMAS; Barnert Mill; Silk (S) Dress Goods; 28 looms; steam; Spielmann & Co., N. Y., s. agts.
- GOLDMAN, CHAS; (successor to Albion (S) Silk Co.) 52 Washington St; Broad Silks; 10 looms; steam; sell direct. *Not running; for sale.*
- GRAEF HAT BAND MFG. Co, THE; Hat- (S) ing Mill; \$100,000; Walter H. Graef, pres.; Hat Bands; W. H. Graef & Co., N. Y., s. agts.
- GRAHAM, G.W. Co, THE; Bishop Mill; East (S) 13th St.; \$25,000; Geo. W. Graham, pres., treas. and supt.; Silk Throwing on Commission; 7,000 spindles; steam.
- GRANITE LINES Co; Granite Mill; Frank (L) Woodhead, agt; Linen Towels and Napkins; 100 looms; steam; bleach; Jas. El-Hot & Co, 370 Broadway, N. Y., s. agts. (Buy cotton and linen yarns.)
- GREEN, M. J; Dale Mill; P. O. Box 1359; (S) Dress and Tie Silks; 120 looms; steam; M. Warner & Co., N. Y., s. agts.
- GREGORY, WM.; Essex Mills; Braids; 40 (S) Braiders.

- GRIMSHAW BROS.; Dale Ave. and Slater (S St.); Broad Silks, Handkerchiefs, Tie Silks, Etc.; 555 looms; steam; dye and finish; S. Peierls & Co., 10-12 Greene St., N. Y., s. agts. (Also Reading, Pa.)
- HAENCHEN BROS. SILK CO.; 1 Broadway; (S \$100,000; Otto Haenchen, supt., Tie Silk, Tailor's Linings, and Umbrella Silk; 180 looms; electric; C. A. Auffmordt & Co., and Richard H. Fraenkel, Schaefer, Schraumm & Vogel, N. Y., s. agts.; Fred Haenchen, buyer.
- HALEY, ROBT. A.; Cooke Works; Silk (S Throwster; 5000 spindles.
- HAMILTON & BOWLES; 46 Knickerbocker (S Ave.; Broad Silks and Fancies; 25 looms; gas; Jos. Hirsch & Sons, N. Y., s. agts.
- HAND, JOHN & SONS; West RR. & Gould (S Ave.; Silk Ribbons and Dress and Tie Silks; 10,000 spindles; 500 looms; steam; J. Kridel, Sons & Co., N. Y., s. agts. (Branch at Wilmington, Del.)
- HARROW & CO; 159 Ryerson Ave; Rib- (S bon-; 3 looms.
- HAWTHORN SILK CO. THE; office River (C&S & Putnam Sts; (mill at Hawthorne); \$100,000; J. J. Bailey, pres; D. Ashley, Jr, treas; Silk, Cotton and Mixed Goods.
- HELVETIA SILK MILL; (N. Y. office, 96 (S Spring St.); 6th Ave. and 11th St.; \$100,000; J. Fred Baer, pres.; Thos. M. Scheidler, treas.; Fred A. Baer, supt.; Ribbons and satin Back Velvet Ribbons; 160 looms; Fred'k Victor & Achelis, N. Y., s. agts. (Also Lehighton, Pa.)
- HENSHALL, THOS.; Dale Mill; Finisher of (F Broad Silks and Satins; steam; dye.
- HERMANN, A. (Formerly with Stern, (S Pohley & Harmann) to start separate plant in the spring.
- HOLDEN, WM. R.; Broomhead Mill; Silk (S and Mohair Braids; 210 Braiders; sell direct.
- HOLLBACH, JOHN, & Co; New Hall Mill; (S Fulton and Summer St.; Tie Silks; 180 looms; steam; Fred'k Victor & Achelis, N. Y., s. agts.
- HOLMES SILK COMPANY; Barnet Mill; W. (S B. Phillips, pres. and treas.; Broad Silks, Grenadines, Handkerchiefs and Mullers; 420 looms; steam; G. M. Donaldson in charge of selling; W. B. Phillips, buyer. (Buy all kinds of silk yarns, also fancy cotton and wool sted yarns.) (Also Williamsport, Pa.)
- HOLT, WM.; 108 Straight St; Turkish (C Towels, Terry Cloths and Dusters; 16 looms; steam.
- HOLZMAN SILK MFG. CO; Industry Mill; (S Van Houten St; \$100,000; S. L. Holzman, pres; H. S. Holzman, treas; Samuel S. Holzman, manager; Plain and Fancy Ribbons; 30 looms; steam and water; Schefer, Schraumm & Vogel, N. Y., s. agts.
- HOPPER & SCOTT; Hope Mill; Commis- (S ion Throwsters, Organzine and Tram; 11,000 spindles; steam and water; John H. Hopper, buyer.
- INGLIS & CO; Ball Mill; Summer & (S Montgomery St; Throwsters; 9400 spindles; steam; W. M. Inglis, buyer.
- ISLEIB & McLANE; New Barnet Mill; (S Throwsters on Commission; 6,800 spindles; steam.
- JACKSON, JAS. & SONS; 20 Albion (D & F Ave; Piece Goods, Cotton Velvets; steam. Also at Little Falls, N. J.
- JANSEN & PRETZFELD; Rock Mill; (In (S Waverly Mill); Broad Silks; 48 looms; N. Y. office, 457 B'way. (See also Meisch mill).
- JENKINSON, L.; McAlister Mill; Hori- (W zontal Warping and Winding on Commis- sion; 14 warpers; 7 winders; steam and water.
- JOHNSON, COWDIN & CO; Riverside; Rib- (S bons and Throwing; 12,000 spindles; 210 looms; steam; dye; N. Y. office, 121 Spring St. (Also Phoenixville, Pa.)
- KATTERMANN & MITCHELL CO.; Eastwood (S Mill; \$100,000; August Kattermann, pres.; James Mitchell, treas.; Dress Silks, etc.; 150 looms; Fred Victor & Achelis, N. Y., s. agts.
- KAUFMAN BROS.; Addy Mill; Broad (S Silks; 14 looms; steam and water; sell direct.
- KANTER, I; (formerly Novelty Trim- (Pr ming Co.); Blackburn Mill; Furniture Trimmings; 10 looms. (Buy 12 ply and 42 ply cotton yarn.)
- KEARNS BROS; Wood and Shady Sts; (D Skein Silk Dyers.
- KEMPKES BROS. (formerly Schellenbach (S & Co.); Essex Mill; Black Broad Silks; 12 looms; water; sell direct.
- KNIPSCHER & MAASS SILK DYEING CO; (D Gun Mill; \$500,000; W. E. Knipscher, pres.; Frank Maass, treas. and supt.; Silk Skein Dyers on Commission.
- KRUGER & STOHN; (Lakeview); Tie (S Silks; 80 looms.
- LAMOND & ROBERTSON CO, THE; (River- (J side); \$75,000; John S. Lamond, pres; Colm T. Robertson, treas. Smyrna Rugs, Hemp and Napier Matting and Jute Rugs; 76 looms; steam; dye; sell direct; C. T. Robinson, buyer. (Buy jute, cotton and woolen yarns.)
- LAUREL SILK WORKS; Walder Mill; 28 (S Fulton St; Aurel Meekel, pres. and treas; R. Trompeter, see; Dress Silks; 141 looms; steam; Fred'k Victor & Achelis, N. Y., s. agts.
- LEVY, A. & M.; (successors to Levy Bros.); (S 165 River St; 86 Greene St, N. Y.; Ribbons; 150 looms; steam; dye; sell direct.
- LIBERTY SILK DYEING CO.; Waverly (D Mill; \$50,000; Adam Jaeger, pres.; George W. Cole, Jr., treas. and buyer; Skein Silk Dyeing, Commission Dyers.
- LINCOLN SILK CO; Dale Mill; 33 RR. Ave; (S \$25,000; Samuel Kubic, pres; W. Wimpfheimer, treas.; Albert Mercer, supt.; Tie Silks; 70 looms; steam; A. Wimpfheimer & Bro.; N. Y., s. agts.; Albert Meerer, buyer.
- LITTLE, W. & CO; 235 Preakness Ave; (S Samuel Aitken, supt.; Broad Silks, Tie and Millinery Silks and Linings; 116 looms; steam; Schefer, Schraumm & Vogel, s. agts.; W. Little, buyer.
- LOCKMAN, RICHARD & SON; Essex Mill; (S Silk Ribbons; 20 looms; L. Erstein & Bro., s. agts. *Sold*.
- LOMBAERDE, CHARLES; Murray Mill; (S Cor. River and West Sts; Broad Silks, Taifetas; 60 looms; Oelbermann, Dommerich & Co., N. Y., s. agts.
- LOUISIANA SILK CO.; Merrill Mill; Taf. (S fetas; 8 looms; steam; A. Stave, buyer.
- LOVE, ROBERT; Hamilton Mill; Grena- (S dines; 12 looms; water and steam; sell direct.
- LOYAL SILK CO; Harmony Mill; 8 looms. (S
- LUCAS & Co.; Gordon Mill; Silk Veilings; (S 10 looms; sell direct.
- MACKAY & ROWSON; Silk Throwster on (S Commission; 6000 spindles; steam; P. R. Rowson, buyer.
- MAGRATH, AMMANN & ARNOLD CO, 58- (D 62 Garfield Ave; \$50,000 Frank Arnold, pres; Francis G. Magrath, treas. and agt; Emil Ammann, vice-pres. and supt; Skein Silk Dyeing.
- MANHATTAN SILK CO.; Addy Mill; Ryle (S Ave.; Silk Ribbons; 20 looms. (Formerly Lockman Bros. Silk Co.)

- MASON SILK MILLS, THE; 44 Front St; J. (S) H. Smallwood, supt; Fancy Broad Silks; 300 looms; steam; E. T. Mason & Co., 28 32 Greene St, N. Y., s. agts.
- MAYHEW SILK CO.; Barnert Mill; 80 (S) looms. (Also see Juniata Throwing Co., Altoona, Pa.)
- McCULLOCH, ROBT; 42 Van Houten St; (S) Embroidery and Spun Silks.
- MEDING MFG. CO; Granite Mill; Grand (S) St; \$450,000; C. E. Meding, pres., and treas; Silks and Ribbons; 250 broad looms; 200 ribbon looms; steam; sell direct; Y. Y. office, 57 Greene St.
- MEREDITH, SAMUEL; 20 and 22 Olive St; (S) Wm. Meredith, supt; Throwing; 900 spindles; electric power. *Mill burned, Feb. 02, May resume.*
- METEOR SILK CO.; \$30,000; Ellison and (S) Straight Sts. *Proposed.*
- MEYER, F.; Franklin Mill; Mill St. foot (S) of Ellison; Silk Throwster; 1,000 spindles; water.
- MIESCH MILLS; Jansen & Pretzfeld; (for- (S) merly Miesch Mfg. Co.; Tie Silks; 62 looms. (Also operate Rock Mill.)
- MILLER & WARD COMPANY; Eastwood (S) Mill; \$15,000; Broad Silks; 60 looms; steam; Howard Naylor, with Doull, Miller & Co., N. Y., s. agt. (Also operate 22 looms in Barnert Mill.) *See Lebanon.*
- MILLS, JAMES; Gun Mill; Throw. (S) ster; 5000 spindles; steam and water.
- MURPHY BROS; Adams Mill; Tie Goods; (S) 12 looms.
- MURRAY, NICHOLSON; 408 East 21st St; (S) Dress and Tie Silks; 10 looms.
- NAEF BROS. CO; 322 Straight St; \$80,000; (S) Jos. Decker, pres., and treas; Chas. Schlaeffer, sec. and supt; Broad Silks, Etc; 300 looms; steam; Oelbermann, Dommerich & Co, 57 Green St, N. Y., s. agts.
- NATIONAL RIBBON CO; \$150,000; W. W. (S) Depple, pres; Geo. F. Knutt, treas., and supt; Silk Ribbons; 165 looms; steam; Passavant & Co., s. agts.
- NEALE & GOODE; First Ave; Riverside; (D) Skein Silk Dyers; steam.
- NEUBERGER, MEIDENDORF PHILLIPS SILK (S) Co. (formerly Jewell Silk Mill); \$50,000; I. Neuberger, pres.; Henry Meidendorfer, treas.; E. R. Phillips, supt.; Broad Silks; 62 looms; steam; salesroom, 445 Broome St., N. Y.; and Hoennighaus & Curtiss, N. Y., s. agts.; firm buyers.
- NEUBERGER SILK CO; Van Houten St; (S) T. J. Kane, supt; Thrown Silks; 15,000 spindles; water; sell direct; 102 Greene St.
- NEW JERSEY SILK MFG. ASSN; 117-124 (S) River St; \$30,000; Leo Goldmark, pres., and treas.; Louis Teweles, supt.; Broad Silks; 100 looms; steam; John Menke & Co., s. agts.; Leo Goldmark, buyer.
- NEW YORK & BROOKLYN SILK MFG.; (S) Altschuler Bros, props; Fulton Mill; Ward St; Broad Silks; 15 looms; steam and water; S. Briskman, N. Y. s. agt.
- NIGHTINGALE, JOSEPH, (successor (W & S) to George Cox); East 18th St; Silk, Cotton, Linen and Mohair Braids and Linc; 120 braiders; electricity; sell direct.
- NOVELTY SILK PRINTING CO; Van (Pr) Houten St; \$5000; Joseph P. Flood, pres., and treas; Printing; Silk and Cotton Piece Goods, also Flag Printing; steam.
- O'CONNOR BROS; Essex Mill; Mill St; (S) Silk Ribbons; 7 looms; water; Wendt, Steinhauer & Co, N. Y., s. agts.
- OLDHAM MILLS; *Removed to Phila.*
- ORIENTAL SILK PRINTING CO; E. F. Post, (Pr) pres.; H. A. Van Liew, treas; James Roscow, supt.; Print Silks and Silk Mixed Goods for Converters; steam.
- ORION MFG. CO; \$100,000; Frederick Haigh (F) A. B. Hopper and John K. Greenwood, interested. Treating Yacht Cloth, Dress Goods and Similar Fabrics by Special Process. *Proposed.*
- PARAGON SILK CO; Straight, Morton and (S) Madison Sts; \$100,000; E. H. Rosenheim, pres; O. E. Rosenheim, treas; J. H. Bentley, supt; Broad Silks; 460 looms; steam; Jos. A. Blum, 37 and 39 Greene St, N. Y., s. agt. (Branch mill at Onconta, N. Y.)
- PATERSON SILK & DYEING ASSN; (D & F) \$5,000; Pierre Thommerieux and Jacques Heurtier, interested; Dye and Finish Silks.
- PATTERSON BROS. & Co.; Gordon Mill; (S) Joseph C. Patterson, supt. and buyer; Broad Silks; 30 looms; electricity; sell direct.
- PEERLESS PLUSH MFG. CO; (C, W & S) Franklin, Summer and Keene Sts; \$100,000; Wm. H. Fletcher, pres; Otto Jaeger, treas; John F. Taylor, supt; Cotton, Mohair and Silk Plushes; 70 looms; steam; dye; Jaeger & Schmiedel, N. Y., s. agts.; Wm. H. Fletcher, buyer. (Buy from 20/1 up to 50/3 in singles and two and three ply.)
- PELGRAM & MEYER; Matlock and Temple (S) Sts; Broad Silks and Ribbons; 550 looms; steam; dye. (*Also at Bounton, N. J., & Harri- burg, Pa.*)
- PHOENIX SILK MFG. CO; \$1,500,000; Joseph (S) W. Congdon, pres.; John R. Curran, sec. and treas; John C. Dowell, supt; Dress Goods, Linings and Ribbons; 46,000 spindles; 183 looms; steam and water; Greeff & Co., N. Y., s. agts.; Jos. W. Congdon, buyer. (Also at Allentown and Pottsville, Pa.)
- POST & SHELDON SILK CO; Hall Mill; (S) Fulton and Summer St; \$15,000; Samuel Sheldon, pres; Geo. A. Post, sec. and treas; Broad Silks; 4,000 spindles; 300 looms; L. Erstein & Bro., N. Y., s. agts. (Also Dover, Del.)
- POTTS & DURKIN; 19 Fair St; Taffeta and (S) Dress Goods; 11 looms; steam; sell direct.
- RAMSAY & GORE MFG. CO; Empire Mills; (S) \$50,000; John Ramsay, pres; Organzine, Tram, Hard Twists, Corkscrew and Crepe Twist a Specialty; 17,000 spindles.
- REINHARDT, F. C.; Rip Van Winkle Ave. (S) and North 7th St.; Geo. F. Feuerstein, supt.; Braids, Suspender and Trimming and Shoe Laces; steam; dye; sell direct; F. C. Reinhardt and Geo. F. Feuerstein, buyers.
- RETTGER-ALLEN CO; East 18th St; C. C. (S) Rettger, pres; John Allen, treas; Broad Silks; 100 looms; electric; H. A. Lindgren & Co. N. Y., s. agts.
- RILEY, EDWARD (P. O. Box 1234); Mill (D) St.; Silk Yarn Dyer.
- RIVERSIDE SILK CO; Essex Mill; Mill St; (S) Broad Silks; 12 looms; sell direct.
- ROBERTS, CHAS. E; 153 East 20th St; Rib- (S) bons and Shoe Facings of all descriptions; 8 looms; sell shoe facings direct; Wm. P. Gill & Co., s. agts. (Buy 30/2 and 40/2 yarns.)
- ROSE SILK MFG. CO.; Hamilton Mill; (S) Broad Silks; 50 looms; sell direct. (Formerly Chaxton & Laird.)
- RYAN, D. V. & Co; 119 Lewis St; Twist, (S) Braids and Fish Lines; sell direct
- RYER, JAMES B., SON & Co.; Ryewaner (S) Mills; Upholstery Goods, Silk and Cotton Mercerized, also Drapery Fabrics; 40 looms; steam; sell direct, 451 B'way, N. Y.; Geo. S. Ryer, buyer. (Mill at Haledon.)
- SAPERSTEIN, MR.; 93 River St. (S)
- SARGENT, E. (formerly Eaton & Sutton (S) Mills); Atherton Mill; Tie Silks; 51 looms; sell direct.

- SAYER & CORWIN; Silk Dyers. (D)
- SCHMIDT BROS. MFG. Co.; Murray Mill; (S 21 looms.
- SCHUMACHER, F. & Co; Waverly Mill; (S A. R. Smith, supt; Tapestry Goods; 20 looms; steam and water; sell direct.
- SHEEHAN, DAN, J. Co. THE; (formerly (D D. J. Sheehan); 209 Paterson St.; B. J. Sheehan, pres. and treas.; G. S. Coombs, agt.; F. August Weidmann, supt.; Silk Dyers.
- SIMPSON, JAS. & Co; Haledon Ave. and (S N. 1st St; Dress Goods, Ribbons, Etc; 9000 spindles; 235 looms; steam; dye; A. D. Juilliard & Co, N. Y., s. agts. (Also Scranton and New Hope, Penn.)
- SPRING SILK Co.; Essex Mill; Van Houten (S St.; \$3,150; David Matchett, pres. and supt.; Richard Matchett, treas.; Thos. J. Beardmore, agt.; Taffetas; 17 looms; water and steam; Harry Freeland, s. agt.
- STAR SILK Co.; Harmony Mill; A. Bach, (S supt; Silks, Satins and Taffetas; 16 looms; steam and water; sell direct.
- STERN & POHLEY; (formerly Stern, (S Pohley & Herrman); Market and Jersey Sts, A. A. Herrman, supt; Broad Silks; 150 looms; steam; J. Kridel, Sons & Co, 47 & 49 Greene St, N. Y., s. agts; H. Stern, buyer.
- STRANGE, WM. Co, THE; Madison and (S Essex Sts; \$750,000; A. B. Strange, pres; J. C. Read, treas; W. G. Townley, supt; Dress Goods and Ribbons; 400 looms; steam; sell direct; F. Strozkeski, buyer.
- STRAUS, F. A. & Co; Dale Mill; J. H. (S Lynch, supt; Silk and Worsted Yarns; also sell Cotton Yarn on commission; 10,020 spindles; steam; N. Y. office, 33 Greene St; F. A. Straus, buyer. (Also Trenton and Chester, Pa.)
- SUTHERLAND & EDWARDS Co; Erie and (J East 11th St; \$100,000; E. G. Edwards, pres. and treas; Jute Yarns, Twines, etc; steam; sell direct; E. G. Edwards, buyer.
- SWIFT, JOHN, & Co; \$15,000; Throwsters; (S 10,000 spindles; steam and water.
- TAYLOR, JAMES; 52 Washington St.; (S Tusssah Throwster.
- TAYLOR, JOSEPH; Merrill Mill; Ribbons; (S 1 loom.
- TAYLOR SILK MFG. Co; 16 Bridge St; \$10, (S 000; John W. Taylor, pres; and treas; Handkerchiefs, Mullers, Dress and Tie Silks; 100 looms; steam; sell direct. (Also Dickson, Pa.)
- THRELFALL & STELLE; Broomhead Mill; (S Tie Silks; 18 looms; C. J. Davis, 20 Green St, N. Y., s. agt.
- TIMME, E. F. & SON; Market St; E. F. (F Timme, pres; Otto Timme, treas; Edward Lipsius, supt; Finished Plush; water. Also Swarthmore, Pa.
- TODD, J. C; Jackson and Taylor Sts; (J 203 Broadway, N. Y; Jute Bagging and Twine; 10 looms; steam. *Not running.*
- TOTOWA SILK Co; \$150,000; H. W. Curtiss, (S pres; C. H. Hunter, treas; C. L. Horandt, supt; Silk Ribbons; 80 looms; steam; dye; Hoeninghaus & Curtiss, 471 and 473 Broome St, N. Y., s. agts.
- TYNAN, JOS. E; Dale Mill; Silk Throw (S ster; 5,000 spindles; steam.
- U. S. DYEING & BLEACHING Co.; (D & H 47 River St.; Wright Smith, agt.; Abraham Howarth, mgr.; Merized Cottons.
- WARNER, JOSEPH; Industry Mill; Fancy (S Ribbons; 17 looms; sell direct.
- WEIDMANN SILK DYEING Co. (P. O. Box (D 1826; (Riverside); 5th Ave; Jacob Weidmann, pres., treas. and buyer; Skein Silk Dyeing, steam.
- WESTERHOFF BROS. & NAPIER Co.; Hard (S ing Mill; Van Houten St.; \$100,000; Peter D. Westerhoff, pres. and agt.; Henry Westerhoff, treas.; Dress Silks; 10,000 spindles, 350 looms; salesroom, 31 Green St, N. Y. also at Jamesburg, N. J., and Denver and Ephrata, Pa.
- WHITE, Jos. (formerly Eastwood & (S White); 249-251 Crooks Ave.; \$20,000; Sewing Silk and Veiling; 28 looms; steam; sell direct.
- WIDMER Co. (successors to Allen Ches. (S ters, 19 Fair St; Silk Novelties; 10 looms; steam; sell direct.
- WIERTZ, AUGUST; 17 Madison Ave; (S Ribbons.
- Phillipsburg.** E.3. D. L. & W. RR, Morris & Essex Div; L. & H. R. RR; P. RR, Belvidere Div; C. RR. of N. J.; L. V. RR, Lehigh Div, New Jersey Div.
- ASHLEY & SHAW SILK Co; Branch mill. (S (Also Hackettstown.)
- PHILLIPSBURG HOSTERY MILLS Co.; Sun (K shine Hosiery.
- PHILLIPSBURG SILK MILL Co; See Easton, (S Pa.
- STANDARD SILK Co; \$150,000; D. D. Sut. (S phed, pres; C. A. Braman, treas; S. H. Larned, gen. mgr; Broad silks; 25,000 spindles; 800 looms; steam; dye; A. D. Juilliard & Co, N. Y., s. agts.
- Picton.** F.8. Near Rahway on L. V. RR. (Lenox Station).
- AMERICAN FELT COMPANY; Essex Felt. (W ing Mills; Benj. King, supt; Felt Goods of all Descriptions; 20 sets; steam and water; dye. (See New York City for officers).
- Plainfield.** F.7. C. RR. of N. J.
- WATCHUNG SILK Co; \$25,000; J. H. (S MacDonald, pres; W. R. Coddington, treas; H. C. Kenyon, sec; Ralph Whitney, supt; Broad Silks and Ribbons; 50 looms; steam; Warner & Co., N. Y., s. agts. (Building new mill.)
- Pluckamin.** E.6. D. L. & W. RR.
- PLUCKAMIN MFG. Co; John A. Pow. (W & D elson, pres; Jas. Brown, Jr., (Somerville, N. J.) treas; W. A. Hamilton, supt, 8 oddies; Also Wool scouring and Dyeing; 8 sets; 4 pickers; steam; dye. (See also Somerville, N. J.) (RR. station at Far Hills.)
- Pompton.** C.8. N. Y. S. & W. RR; N. Y. & G. L. RR.
- SLATER, ROBERT; Woolen Yarn; 1 set. (W
- Pompton Lakes.** C.8. 1 m. n. e. of Riverdale. N. Y., L. E. & W. RR.
- GERMAN ARTISTIC WEAVING Co; \$200,000; (S A. C. Kluge, pres. and buyer; P. Goldsmith, supt; Woven Silk and Cotton Labels, Shoe Facings and Novelties; 60 looms; water; sell direct; N. Y. office, 274 Church St. (Buy 30/2 to 200/2 cotton yarn.)
- GIANNETTI, MRS. M. L; Z. Cole, supt; (S Silk Throwing, Tram and Organzine; 5,000 spindles; water.
- MILKBANK BLEACH & DYE WORKS; (H & D Byrne Bros; steam. *Burned.*
- Port Orant.** D.6. C. RR. of N. J., High Bridge Br; D. L. & W. RR, Chester Br, Morris & Essex Div.
- ROSS, E. J. MFG. Co; \$75,000; Edwin J. (S Ross, pres; A. H. Moore, agt.; treas; Fred Schofield, supt; Veils, Dress and Tie Silks; 200 looms; steam and water; dye; Spielmann & Co., N. Y., s. agts; A. H. Mockridge, buyer. (Buy 60/2 soft gassed yarns.)
- SINGLETON, GEORGE; Commission Throw. (S ster; 5,000 spindles. (Also Dover, N. J., and Wadesboro, N. C.)
- Rahway.** F.8. P. RR, N. Y. Div.
- HIRST, W. H.; Smyrna Rugs; 12 looms; 2 (W sewing machines; dye; Chas. Bouget, 3 E 17th St., N. Y., s. agt.

- HOWARD & Co.**; St. George's Ave; (**D**) Dyers and Finishers of Cotton Piece Goods.
- Raritan.** F-6. C. of N. J. RR.
- RARITAN WOOLEN MILLS;** D. L. Ein. (**W**) stein, pres. and treas; Adolph Mack, sec; M. E. Driscoll, supt.; All Classes of Woollen Goods; 30 sets; 194 looms; steam; dye; sell direct; 14 & 16 White St., N. Y.
- SOMERSET MFG. Co.;** \$150,000; D. L. (**W**) Einstein, pres.; Emanuel Einstein, treas.; Adolph Mack, sec.; Harry A. Smith, supt.; Overcoatings and Cloakings; 17 sets; 132 looms; steam; dye; sell direct; 14 White St., N. Y.
- Riverside.** K-4. P. RR, Orehill Br.
- DICK, CHRISTIAN;** Riverside Hosiery (**K & D**) Mills; Cotton, Wool and Worsted Seamless Hosiery; 150 knitting machines; 10 sewing machines; steam; dye; also custom dyer of knit goods; sell direct.
- TAUBEL, Wm. F.;** Popular Hosiery Mills; (**K**) Cotton, Woollen and Lisle Thread Seamless Hosiery; 500 knitting machines; steam; dye; sell direct (Also Shamokin, Pa.)
- Rockaway.** D-7. C. of N. J. & D. L. & W. RR.
- LIONDALE BLEACH, DYE & PRINT (**B, D & Pr**) WORKS;** \$1,000,000; Jacob Loewenthal, pres; E. M. Loewenthal, treas; Harry R. Watson, supt; Bleachers, Dyers, Printers and Finishers of Textile Piece Fabrics, principally Cotton Piece Goods; steam and water; E. M. Loewenthal, buyer.
- Saddle River.** C-9. N. Y. L. E. & W. RR.
- THURSTON-CLARK HOSIERY Co.;** \$20,000; (**K**) F. B. Clark, pres; B. C. Clark, treas; H. W. Thurston, supt; Fine Seamless Ladies' and Children's Hosiery and Half Hose; 30 knitting machines; water and steam; dye; S. W. Smack, N. Y. s. agt.
- Salem.** N-2. N. J. RR, Salem Br.
- SHEPPARD, JOHN, P.;** Salem Knitting (**K**) Mills; Misses' Ribbed, Ladies' Lace and Men's Lace Half Hose; 200 knitting machines; steam; dye; sell direct; 4th. P. Sheppa d. buyer. (Buy 9 to 60 carded peeler and 2/30 to 2/3 Egyptian lisle)
- Somerville.** F-6. Main line of N. J. C. RR.
- SOMERVILLE WOOLEN MILLS, THE;** \$500. (**W**) 000; John A. Powlson, pres; Jas. Brown, Jr, supt. and treas; Worsted, Woollens and Clothing; 6 sets; 67 looms; steam; dye; sell direct; 729 Broadway, N. Y.; James Brown, Jr, buyer. (See also Pluckamin.)
- Stirling.** E-7. D. L. & W. RR, Passaic & Delaware Br.
- STIRLING SILK MFG. Co.;** \$200,000; Adolph (**S**) Rusch, pres; A. F. Streuli, treas; J. Ruegg, sec. and supt; Dress Goods, Light Grade Taffetas, Peau de Soie, Satins, Louisine, etc; 350 looms; steam; Abegg & Rusch, N. Y. s. agts. J. Ruegg, buyer.
- Summit.** E-8. D. L. & W. RR, Morris & Essex Div, Passaic & Delaware Br.
- SUMMIT SILK MFG. Co.;** \$100,000; O. De (**S**) Forest, pres; W. H. De Forest, Jr, sec. and treas; Broad Silks; 1220 spindles; 635 looms; steam; sell direct and Rue, Hallett & Godone, 494 Broome St., N. Y. s. agts; O. DeForest, buyer.
- Sussex.** (Formerly Deckertown.) B-6. N. Y. S. & W. RR.
- DECKERTOWN MFG. Co.;** (Plant purchased by Sussex Mill.) *Firm dissolved.*
- SUSSEX MILLS;** \$20,000; E. L. Gifford, (**C**) pres; C. A. Wilson, treas; W. H. Mellor, agt. and supt; Turkish Towels, Terry Cloth and Specialties; 90 looms; steam; dye and finish; sell direct. (Buy 12/1, 14/1, 20/2, warp; 12/1 skein yarn, 11/1 cop.)
- Tenafly.** C-10. N. RR. of N. J.
- RICHTER MFG. Co.;** Burlap, Buckram, (**C**) Decorative Stuffs, Etc; 16 looms; steam; dye; sell direct; 115 E. 23rd St., N. Y.
- Trenton.** H-5. P. & R. RR, Trenton Br; P. RR, Bordentown Br.
- AGNEW, GEO. & SONS.** (P. O. Address, (**W**) Titusville.) Charles Moorhouse, supt.; reclaimed wool; steam.
- COLONIAL WOOLEN Co. (Inc. 1895);** H. (**W**) C. Smith (Phila), pres; Chas. M. McCloud, (229 Chestnut St, Phila), treas; D. W. Cross, sec; Cassimeres; 4 sets; 86 looms; steam and water; dye and finish; sell direct.
- ORLEANS MILLS;** formerly Samuel K. (**W**) Wilson; Chevots, Overcoatings, Worsted and Cassimeres, 32 sets; 275 looms; steam and water; dye; sell direct. *Sold at auction Mar. 19, to A. H. Ryan, Somerville, N. J.*
- PFIEFER, ANNA;** 570 Perry St; Cardigan (**K**) Jackets, Sweaters and Stockings; 4 knitting machines; sell direct.
- STRAUS & Co.;** Worsted Yarns; 12 combs; (**W**) 48 spinning frames. (See also Paterson and Chester, Pa.)
- TRENTON WORSTED MILLS;** formerly (**W**) Samuel K. Wilson; Worsted Yarns, (Bradford system); 4 sets; 4 combs; 2,500 spindles; steam and water; dye; sell direct. *Sold at auction Mar. 19, to A. H. Ryan, Somerville, N. J.*
- WILLIAMS, JOHN MFG. Co.;** Ed. White (**W**) head, supt; 140 looms; steam; dye; sell direct; 12th and Carpenter Sts., Phila.
- Union.** Hudson County. D-9. via Weehawken. See Weehawken.
- Union Hill.** (P. O. Weehawken.) E-9. Hoboken Ferry from N. Y.
- Vineland.** O-4. C. of N. J. W. J. RRs.
- HIRST SMYRNA MFG. Co.;** (formerly Thos. (**W**) Hirst); \$250,000; Regal Smyrna and Hustler Smyrna Rugs; 300 looms; steam; dye; sell direct and C. W. Bogert, 337 Broadway, N. Y. s. agt.
- NICOL, W. & Co.;** Chenille Curtains; 16 (**S**) looms; steam; sell direct.
- SEARING, M. MUNSON;** Boulevard and (**S**) Wood Sts.; Patrick B. O'Leary, supt.; Silk Throwster (Commission); steam; M. Munson Searing, buyer.
- Washington.** E-4. D. L. & W. RR, Morris & Essex Div.
- WASHINGTON SILK MILLS;** L. Roessel & (**S**) Co.; 113 Grand St., N. Y.; Wm. Speirs, supt; Dress and Fancy Silks; 4500 spindles; 200 looms; steam. (Also Hazelton, Pa.)
- Weehawken.** E-9. N. Y. L. E. & W. Eastern Div; N. Y. O. & W. Hudson Riv. Div; W. S. Hudson Riv. Div; Ferry from N. Y. See also Union and Union Hill.
- ALLIANCE SILK MILL;** Reiling, David & Schoen. (See also West Hoboken.)
- CLIFTON SILK MILLS;** James McCrery, (**S**) pres.; Robert S. McCrery, treas.; Broad Dress Silks; 4200 spindles; 500 looms; steam; sell direct.
- SCHWARZENBACH, HUBER & Co.;** Dress (**S**) Silks; 120 looms; steam. Salesroom, 472 Broome St., N. Y. (Mill at Union Hill.) (See also West Hoboken.)
- SIMON, R. & II;** also Easton, Pa; Dress (**S**) Goods, Ribbons, Velvets and Plushes; 25,000 spindles; 800 looms; steam; sell direct; 63 Greene St., N. Y.
- West Hoboken.** E-9. Hoboken Ferry from N. Y.
- COMBY SILK MILLS;** H. Walder; F. A. (**S**) Arbenz, supt and buyer; Broad Silks; 250 looms; 4000 spindles; steam; Passavant & Co., N. Y., s. ughts. (Also Renovo, Pa.)

GIVERNAUD BROS; 31 Greene St, N. Y; F. (S) Rohleder, supt; Black and Colored Dress Silks; 1,641 looms; steam. (Also at Hackensack, N. J. and Allentown, Pa.)

MANDEL, GEO; Silk, Mohair and (C, W & S) Cotton Braids, etc; steam; office, 109-111 Spring St, N. Y

MEIER, Frank; 420-422 Division St; (D) Trams, Organzines and Skein Silk Dyeing.

NOVAK, JOSEPH; 428 New Boulevard; (W) Woolen Shawls and Petticoats; 6 looms; hand power; sell direct. (Buys yarn.) (Formerly at Union Hill.)

POIDEBARD SILK MFG. CO; Geo. F. Victor, (S) pres; Thos. M. Scheidler, treas; A. Poidebard, gen'l mgr; Broad Silks; 600 looms; steam; Fred'k Victor & Achelis, N. Y. s. agts.

REILING, DAVID, & SCHOEN; Dress and (S) Tie Silks; 200 looms; steam; sell direct, 453 Broome St, N. Y. (Branch Mill at Weehawken and Valley Falls, R. I., Dunmore and Altoona, Pa.)

SCHWARZENBACH, HUBER & CO; Spring (S) and Highpoint Aves; H. Ruegg, supt;

Broad Silks; 1,200 looms; steam; N. Y. office, 472 Broome St. (Also Altoona and Hollidaysburg, Pa.)

**West New York.** E-9. Via Hoboken Ferry from N. Y.

ALLIANCE SILK MILL; See *Weehawken*.

**Woodbine.** P-5. A. C. RR, W. J. & S. RR.

QUAKER CITY KNITTING CO; Jos. M. (K) Kahn, mgr.; Nathan E. Kahn, supt; Boys' and Children's Wool Sweaters, Toques and Camel's Hair/Tam O'Shanters; 125 knitting machines; electricity; sell direct; Jos. M. Kahn, buyer. (Main office and salesroom 240 Chestnut St., Phila.; N. Y. office, 396 B'way.)

**Wortendyke.** C-9. N. Y. S. & W. RR.

ELLIS & Co. Linens. *Proposed.* (L) MAYHEW, FRANCIS H. (See Paterson, N. J., and Altoona, Pa.)

**Yardville.** J-6. P. RR, Amboy Div. MORRIS & Co; Groveville Mills; Cotton (C) Duck, Bags, etc., Cotton Carpets; 7500 spindles; 176 looms; steam and water; sell direct.

VOGDES, J. W. *Out of business.*

## NEW MEXICO.

No map.

For explanation of abbreviations see page 66.

**Albuquerque.** A. T. & S. Fe RR; S. Fe P. RR.

ALBUQUERQUE WOOL SCOURING MILLS; (W) \$25,000; J. H. Bearrup, pres.; V. P. Eddie, treas.; Jas. Wilkinson, supt.; Scoured Wool; steam.

**East Las Vegas.** A. T. & S. Fe RR.

WHITE WOOL SCOURING CO.; Wm. White; (W) capacity, 8,000 lbs. per day.

**Las Vegas.** A. T. & S. F. RR.

ARNOT WOOL CO, THE; Geo. Arnot, (W) mgr; Wool Scourers; 8 machines; steam.

LAS VEGAS WOOL PULLING CO, THE; (W) \$10,000; James Robbins, treas; Thomas Ross, mgr, and buyer; Scoured Wool and Glove Leather; steam.

LUDEMANN WOOL CO; Geo. Arnot, mgr; (W) Wool Dealers and Scourers; 4 machines; steam.

ROBINS, JOHN, WOOL SCOURING CO; (W) John Robbins, treas; Wool Scouring; 3 machines; steam. (P. O. address, East Las Vegas.)

ROSS & BROWNE WOOL SCOURING CO., (W) THE; \$20,000; Thomas Ross, pres. and buyer; E. L. Browne, treas; James Gilet, supt.; Wool Scouring; sell direct.

# For "Good Goods at Fair Prices"

APPLY TO



MILLS AND P O ADDRESS

ESSEX JUNCTION, VERMONT.

Outside of all Bobbin Mill Combinations.



## NEW YORK.

See map on page 162.

For explanation of abbreviations see page 66.

**Albany.** H. IS. B. & A., N. Y. C. & H. R. W. S. R.Rs.

**ALBANY FELT CO.**; 17 Thatcher St.; (in-**W**) cor. 1895; \$150,000; Jas. W. Cox, pres. and treas.; D. M. Fuller, supt. and buyer; Paper Makers' Felts and Jackets; 2 sets; 15 looms; steam; dye; sell direct.

**BARNET, WM.**; Cor. Westerlo & Church (**W**) Sts.; V. Water-street, supt.; Wool Shoddies; 7 double shoddy cards; 3 pickers; steam; dye; sell direct; Wm. Barnet, buyer.

**FULD & HATCH CO.**; \$250,000; Cor. Hamil. (**K**) ton and Liberty Sts.; Men's, Ladies' and Children's Silk, Cotton and Worsted Ribbed Underwear; (buy yarns 8 to 36); 90 knitting machines; steam; sell direct; firm, buyers.

**GRAVES, FRANK B.** *Sold machinery.*

**HOLROYD, JAS.**; Lake and Hudson Sts.; (**K**) Ribbed Wool Underwear; sell direct.

**HOLROYD, SIMEON**; Full Fashioned La- (**K**) dies' Worsted Underwear; A. D. Hawley, N. Y., H. W. Sylvester, Boston, s. agts.

**HEYCK, F. C. & SONS.** (Mill at Reuss. (**W**) clac.) Paper Makers' Felts and Jack-ets; 6 sets; 31 looms; steam; sell direct.

**NOVELTY KNITTING CO.**; 310 Broadway; (**K**) \$50,000; Oscar Smith, pres.; Collins Arnold, treas. and sec.; Knit Goods; buy cloth all knit or in roll, then finish; sell direct.

**STONEMAN, G. T.**; 48 Hudson Ave.; Knit (**K**) Goods; 14 knitting machines.

**Amsterdam.** G-17. W. S., N. Y. C. & H. R.Rs.

**AMSTERDAM KNITTING CO.**; Full Fash- (**K**) ioned Sweaters, Glove and Mitten Linings and Knit Tubing for Glove and Mitten Manufacturers; 50 knitting machines; steam; sell direct. (Buy yarns, 8 to 20.)

**AMSTERDAM SILK MILLS**; Louis Lich- (**S** & **K**) tenheim, prop.; Silk, Wool and Cotton Fabric Gloves and Mittens; 200 sewing machines; steam; sell direct; 508 Broad- way, N. Y.; A. Hartfield, buyer. (Also Hoboken, N. J.)

**AMSTERDAM WOOLEN CO.**; J. E. Water- (**W**) bury, pres.; H. T. Waterbury, treas.; Men's Wear, 7 sets; 40 looms; 2200 mule spindles; steam; dye; Fred'k Vietor & Achelis, N. Y., s. agts. (Buy cotton warp 2/20s to 2/40s.)

**ATLAS KNITTING CO.**; \$50,000; J. H. Giles, (**K**) pres.; F. R. Greene, secy.; W. C. Schauf-ler, treas. and supt.; Staple and all kinds of Fancy Knit Goods; 6 sets; 50 knitting machines; steam; dye; Cooley, Turnbull & Co., N. Y., s. agts.; W. C. Schauf-ler, buyer. (Buy cotton yarn 10 to 22s.)

**BECKER, CHAS. W.** agt.; F. N. Becker, (**W** & **D**) supt.; Shoddy, Cotton Dyeing, Wool Car- bonizing, Garnetting, Picking and Card- ing; 24 cards; 5 garnetts; 3 pickers; steam and water; dye.

**BLOOD KNITTING COMPANY**; \$18,000; **K** John D. Blood, pres.; John R. Blood, treas.; Men's and Boys' Cotton Ribbed Goods; all weights and grades; 45 knitting ma- chines; steam; dye; sell direct; N. Y. of- fice, N. Y. Life Bldg.; John R. Blood, buyer yarns, etc.; John Barnes, supplies; (buy 8 to 20 yarns.)

**BROOKSIDE KNITTING MILL.** *Out of business.*

**CONSOLIDATED WOOLEN FELT MILLS**; (**W**) not inc.; Geo. Standfield, prop.; General Line, Felts, Saddle, Shoe, Polishing, etc.; 12 cards; 4 preparers and 4 hardeners; steam; dye; sell direct.

**DEAN, L. L. & Co.**; Park Knitting Mills; (**K**) (Mills 8th Ward; formerly known as Rokton); scarlet, Natural Wool, Camel's Hair and Fancy Wool Underwear; 1056 spindles; 5 sets; 19 knitting machines; steam and water; dye; sell direct; (buy 20 to 22 yarn.)

**ERIE KNITTING MILL**; H. K. Salisbury, (**K**) supt. and buyer; Men's and Boys' Jersey Ribbed Underwear; 40 knitting machines; 60 sewing machines; steam; dye; Critten, Clift & Co., N. Y., s. agts.; (buy 6 to 24 yarns.)

**GARDINER & WARRING CO.**; \$125,000; (**K**) Ladies', Children's and Men's Underwear; 77 cylinders; steam; dye; A. D. Juilliard & Co., N. Y., s. agts.; both partners, buyers; (buy 8 to 20 yarns.)

**GREENE KNITTING CO.**; \$100,000; James (**K**) Voorhees, pres.; J. K. Warnick, treas.; Underwear; 14 sets; 3736 mule spindles; 105 knitting machines; steam and water; dye; Cooley, Turnbull & Co., N. Y., s. agts. (Shut down indefinitely.)

**HARROWER, L. E.**; Wool, Cotton and (**K**) Merino Underwear; 12 sets; 50 cylinders; 120 sewing machines; steam and water; dye; sell direct; L. E. Harrower, buyer. (Also Hagaman's Mill.)

**HULL, SMITH & CO.**; Royal Knitting Mills; (**K**) Men's Fancy Striped and Mixed Goods and Ladies' Jersey Ribbed Cotton and Wool Underwear; 41 knitting machines; steam; dye; Cooley, Turnbull & Co., N. Y., s. agts. and sell direct; (buy 9 to 20 yarn.)

**LIDDLE KNITTING CO.**; \$10,000; W. S. Van (**K**) Brocklin, pres.; John Liddle, sec.; Thos. Liddle, treas.; Underwear and Over-shirts; 4 sets; 6 knitting machines; 15 cylinders; 25 sewing machines; steam; dye; W. H. Rowe & Son, N. Y., s. agts. *Not running.* (Operating Spartan Mill.)

**LOEVENHEIM, L.**; Gloves and Mittens; (**K**) 15 knitting machines; hand power; sell direct.

**MCCLEARY, WATLIN & CROUSE.** (See Smyrna Rug Mfg. Co.)

**MCELWAIN, WILLARD, EST. OF.**; Acorn (**K**) Knitting Mills; *Out of business. Machinery sold.*

**MCFARLAN & CO.**; Knit Goods, Ladies' (**K**) and Men's Underwear; 7 sets; 40 knitting machines; 60 sewing machines; steam; dye; buy 12-1, 30-1 white, colored and fancy cotton yarns; A. D. Juilliard & Co., N. Y., s. agts.

**MITCHELL BROS.**; P. Mitchell, supt.; (**W**) Shoddy; Custom Work; 3 cards; 2 large rag pickers; water; P. Mitchell, buyer.

**MOHAWK MILLS**; Smyrna Rug Mfg. Co.; (**W**) \$500,000; Smyrna Rugs, Mats and Carpets; 300 looms; steam and water; dye; W. & J. Sloane, N. Y., s. agts.

**MORRIS, A. V. & SONS**; Knit Goods; 18 (**K**) sets; 100 cylinders; steam; dye; Wm. Ise lin & Co., N. Y., s. agts.; Francis Morris, buyer. (Also No. 2 Mill at Fort Johnson.)

**ROWE & BEST**; South Side Knitting (**K**) Mills; J. J. Best, supt. and buyer; Ladies' Knit Underwear; 21 knitting machines; 30 sewing machines; steam; sell direct. *Shut down.*

**ROWE, W. H. KNITTING CO.**; \$300,000; W. (**K**) H. Rowe, Jr., pres.; Frances J. Wood Rowe, treas.; E. E. Hartzell, sec.; Thomas A. Gal- vin, supt.; Men's Wool Underwear and Bal-

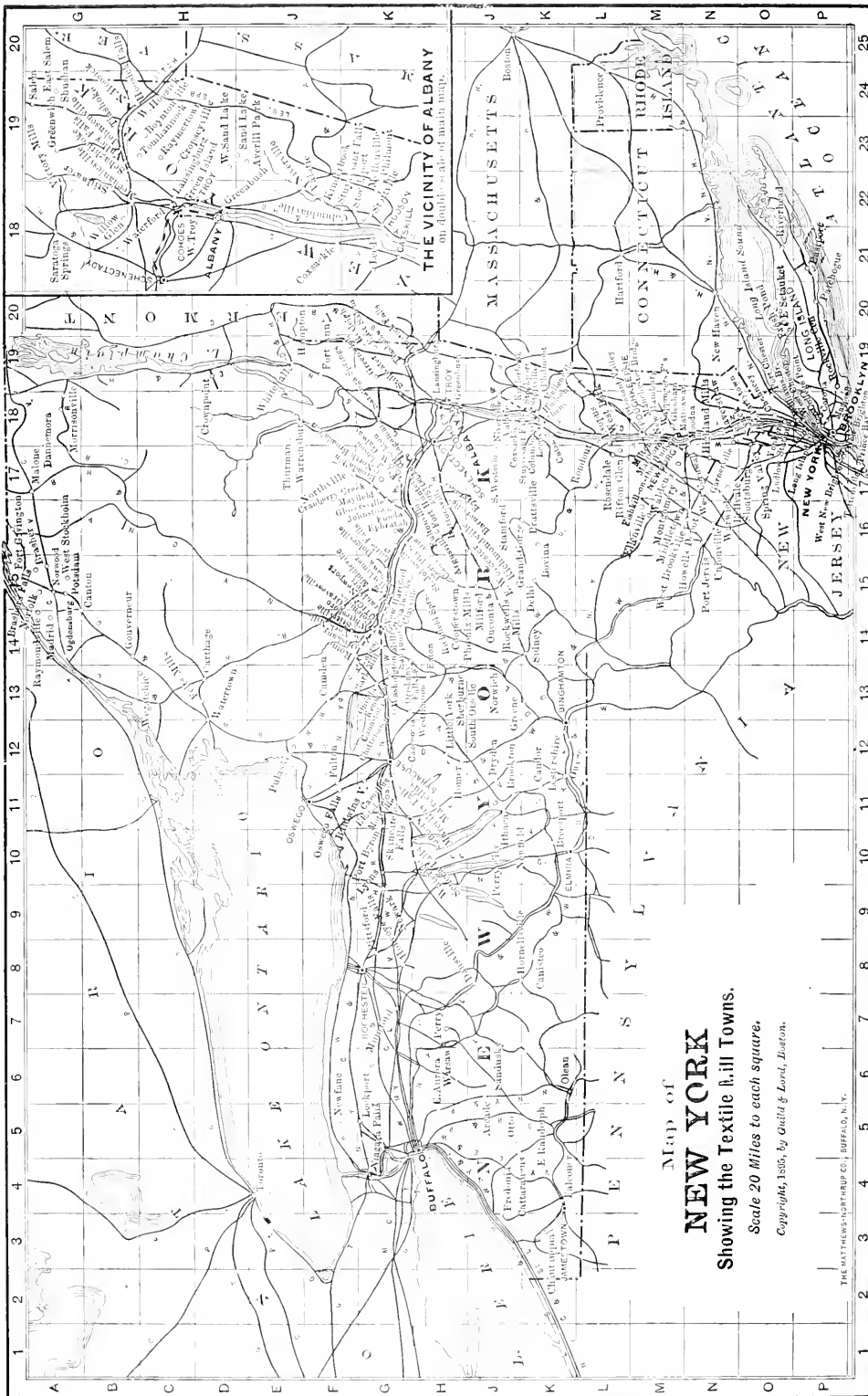

Map of  
**NEW YORK**  
 Showing the Textile Mill Towns.  
 Scale 20 Miles to each square.  
 Copyright, 1955, by Gould & Lord, Boston.

- biggans; 6 sets; 1860 spindles; 35 knitting machines; steam and water; dye; W. H. Rowe & Son, s. agts.; E. E. Hartzell, buyer. (Also Huntsville, Ala.)
- SALISBURY, H. K. & SON.** See *Erie Knitting Mill.*
- SANFORD, STEPHEN & SONS; Axmin (W & C** ster, Brussels, Tapestry, Velvet and Moquette Carpets; Cotton Wamps and Yarns (for carpets); 46 sets; 350 looms; 14 combs; 5000 spindles; 40 cotton cards; steam and water; dye; sell direct; 29 Union Sq; New York; Boston, Chicago.
- SHUTTLEWORTH BROS. Co.; \$100,000; H. L. (W** Shuttleworth, pres.; W. G. Shuttleworth, treas.; Body Brussels Carpets and Rugs; steam; dye; W. & J. Sloane, N. Y., s. agts. (To build a new mill.) (Buy cotton and worsted yarn.)
- SHUTTLEWORTH, H. L.; 146 West Main St; (D** Custom Dyeing; steam; dye; sell direct.
- STEWART, JOHN K.; Chucununda Hqs. (K** iewary Mills; Men's, Ladies' and Children's Fleece Lined Goods; 11 sets; 70 knitting machines; steam and water; dye; sell direct; office at 51 Leonard St, N. Y.; (buy 9 to 30 yarns).
- VAN BROOKLIN & STOVER Co; Mont. (K** gomery Mills; \$90,000; Wm. S. Van Brocklin, pres.; W. H. Rowe, Jr., treas.; Chas. C. Washburn, sec.; Geo. B. Stover, supt; Cotton and Wool Fleece and Summer Balbriggan Underwear; 6 sets; 36 cylinders; 12 rib frames; 1890 spindles; steam; dye; W. H. Rowe & Son, 93 Franklin St., N. Y., s. agts; Wm. S. Van Brocklin, buyer; (buy 20 to 30 yarn.)
- WALLIN & NOLAN. Out of business.**
- WARNER'S, JOHN, SONS; Progress Mill; (K** Plain and Ribbed Underwear and Over-shirts; 5 sets; 17 knitting machines; 35 sewing machines; steam and water; dye; Converse, Stanton & Co. and F. M. Farber & Co. N. Y., s. agts. *Not running.*
- WEST SHORE KNITTING MILLS; Samuel (K** Winters; Ladies' Jersey Ribbed Underwear; 45 knitting machines; 30 sewing machines; steam; sell direct; (buy yarns, 8 to 25.)
- YUND, KENNEDY & YUND; Fancy Light (K** and Heavy Knit Underwear; 482 spindles; 16 sets; 100 knitting machines; steam; dye; A. D. Juillard & Co. N. Y., s. agts; any member of firm, buyer.
- Arcade. J.6. W. N. Y. & P, Buffalo Div, B.** A. & A. RRS.
- FASHION KNITTING MILL Co; Men's, (K** Ladies' and Children's and the "Modestie" Union Suit, Ribbed Underwear; 36 body machines and 36 sleeves; water; steam; sell direct; J. C. Sanford, buyer.
- Astoria. P-18. Ferry from New York.**
- INGRAM, DAVID; Estate, L. I. City Div (D** Works; W. P. Ingram, supt; Dyeing and Bleaching of Cotton Yarns; and Mercerized Cotton on Spools, Skain or Cone; steam; New York office, 167 Wooster St.
- MIGEL, M. C. & Co; Gotham Silk Mills; (S** L. Spoer, supt; Broad Silks and Dress Silks; 80 broad and 140 narrow looms; steam; H. A. Caesar & Co., N. Y., s. agts. (Also Baltimore, Md.)
- WLD, JOS. & Co; Astoria Carpet Mills; (W** Table, Stair and Enamel Oil Cloth Smyrna Rugs, Ingrain Art Squares; 120 hand looms; 55 power looms; steam; dye; N. Y. office, 82 Worth St. (Also Brooklyn.)
- Athens. K-18. RR. Station West Athens;** West Shore RR.
- ATHENS KNITTING Co; \$45,000; Fred. (K** erick Jessup, pres.; F. J. Sagendorph, treas.; C. Whitbeck, sec.; John McGinnis, supt; Fleece Lined Underwear; 4 sets; 1532 spindles; 35 knitting and 55 sewing machines; steam; sell direct, and Converse, Stanton & Co, N. Y., s. agts; John McGinnis, buyer.
- Auburn. G-11. N. Y. C. & H. R. RR, Auburn** Br. L. & Auburn, Seneca and Utica Brs.
- AUBURN BLANKET Co.; Golden Fleece (W** Mills; H. C. Nellis, pres. and mgr.; James Stern, treas.; F. C. Straat, sec.; High Grade California Blankets; 5 sets; 27 looms; steam and water; dye; T. Kelly & Co., s. agts.; N. Y. office, 41-43 Greene St. (Operate Melrose Wool-n Co.'s mill.)
- AUBURN WOOLEN Co, THE; \$100,000; (W** Jesse H. Metcalf, pres.; Stephen O. Metcalf, (Prov. R. I.) treas.; T. M. Clark, supt; Meltons, Tibets, Coatings, Etc; 25 sets; 112 looms; steam and water; dye; Metcalf Bros. & Co, 57 Worth St, N. Y., s. agts.
- COLUMBIAN CORDAGE Co; \$300,000; E. D. (J** Metcalf, pres.; J. C. Anderson, treas.; Benj. Bodell, supt; Sisal and Manila Rope, Twine and Cordage; steam.
- KIDNEY & BRIDEN Co; \$28,000; H. R. Kid- (S** ney, pres. and treas; Silk Goods; 80 looms; steam; H. A. Caesar & Co., 20-26 Greene St, N. Y., s. agts.
- NYE & WAIT CARPET Co; \$100,000; G. H. (W** Nye, pres. and treas; W. F. Wait, mgr; Ingrain Carpets; 11 sets; 3 combs; 150 looms; steam and water; dye; H. B. Claffin Co, N. Y., s. agts; firm, buyer.
- STATE PRISON; J. Warren Mead, (W & L** agt; O. C. Hall, supt; Blankets and Woolen and Linen Goods; 6 sets; 36 woolen and 58 linen looms; steam and water; dye; sell only to State Institutions.
- Averill Park. J-19. Electric Cars from** Troy.
- FAITH KNITTING Co; \$60,000; Bever. (K** wyek & McConihe Mills; Peter McCarthy, pres.; Wm. D. Mahoney, treas. and supt.; Plain and Colored Balbriggan, Plain and Fancy Cotton and Wool Goods; 5 sets cards; 1200 spindles; 32 knitting machines; water and steam; dye; Muir & Malone, 253 Church St, N. Y., s. agts. Wm. D. Mahoney, buyer. (Buy No. 16 to 22 white carded peeler in cops and cones.)
- Baldwinsville. G-11. D. L. & W. RR, Os-**wego & Syracuse Div.
- ALLEN, ALEXANDER; Allen's Mill; La- (K** dies' Nursing Vests and Union Suits, Patented; Ladies' Ribbed Underwear in Cotton, Lisle Thread, Mercerized Yarn and French Spun Worsteds, also Ladies', Misses' and Children's Winter Mittens; 38 knitting and 26 sewing machines; steam and water; dye and bleach; sell direct. (Formerly at Philadelphia.) (In J. C. Miller's Mill.)
- Binghamton. K-12. Erie RR.**
- BINGHAMTON FELTING Co; \$75,000; T. (W** B. Cray, pres.; M. J. Corbett, sec. and treas.; J. Slingerland, agt.; Felts of all description not Woven; 8 sets; steam; dye; J. T. Smith & Co., N. Y., s. agts.; agt. and supt., buyers.
- Bovina. K-16. N. Y. O. & W. RR, Delhi** Branch
- JOHNSON BROS; Flannels and Yarns; (W** 1 set; 3 looms; steam and water; dye.
- Brusher Falls. A-15. C. V. RR, Ogdens-**burg & Lake Champlain Divs.
- STAFFORD, J. P.; (Estate of); A. A. Bald. (W** win, trustee; Cassimeres; 1 set; 5 looms; water; dye; sell direct. *Not running.*
- Broadalbin. G-17. F. J. & G. RR.**
- BROADALBIN KNITTING Co (Ltd); \$75. (K** 000; D. D. Crouse, pres. and treas; B. C. Smith, sec; W. J. Kennedy, supt; Underwear; 8 sets; 1920-silk spindles; 40 knitting and 45 sewing machines; water and steam; dye; Converse, Stanton & Co, N. Y., s. agts; D. D. Crouse, buyer.

- Brooklyn.** P-18. L. I. RR; N. Y. & R. B. RR; N. Y. & S. B. RR; F. R. Line; H P D. Line.
- AIKMAN, C. M. & Co;** Plushes, Ve. (C & S looms Corduroys, Velvets, etc.; 100 looms; steam; dye; sell direct; N. Y. office 91-93 Fifth Ave.
- ALLEN'S, D. SONS ROPE CO;** 3rd Ave. and (J) 6th St; \$25,000; Isaac L. Allen, pres; Darius H. Allen, treas; Cordage.
- AMERICAN MFG. CO;** L. F. Jones, treas., 65 (J) Wall St., N. Y.; Chas. J. Norris, mgr; Jute Bagging and Cordage; steam. (See New York & St. Louis, Mo.)
- BARNARD, GEO. & CO;** 6th Ave. and Pacific (K) St; \$100,000; W. T. Brown, pres.; H. W. Marion, treas. and supt; Athletic Goods, Sweaters, Jerseys, etc.; 25 knitting and 125 sewing machines; steam; A. G. Spalding & Bros, s. agts. (Buy worsted yarn)
- BARON, STRAUS & Co;** Wythe Ave. and (K) Penn St; Men's Underwear, Sweaters, Bathing Suits, Cardigan Jackets, etc; 300 knitting machines; 150 sewing machines; steam; dye; sell direct and Wm. Iselin & Co., N. Y., s. agts.
- BERGLUND, C. C;** 573 Atlantic Ave; Dress, (S) Cloak and Upholstery Trimmings, Church Fringes a specialty; sell direct.
- BOOTH, W. J.** rear 133 Nassau St; Dress (S) Trimmings; 2 looms.
- BRAUTIGAM, ROBT;** Roebling and No. (C) 10th St; Sugar Refiners' Filter Bags, Press Cloth and Blankets; 40 looms; steam; sell direct. (Buy coarse and fine cotton yarns).
- BRILL BROS.;** 729 Metropolitan Ave.; (K) Sweaters, Cardigans, Golf and Bicycle Hosiery; Sknitting machines; B. F. Brown & Co., N. Y., s. agts.
- BROOKLYN KNITTING CO;** 11-17 Lorimer (K) St; D. Nusbaum, prop; Silk, Silk and Wool and Wool Sweaters, Underwear, Jerseys and Bathing Suits; steam; sell direct; D. Nusbaum, buyer (Buy worsted yarns).
- BROOKLYN SILK DYE WORKS;** 401 Manhattan Ave; Dyers and Finishers of Skein Silks and Piece Goods in Blacks and Colors; steam.
- BROOKLYN SILK MILLS** (Successor to F. W. Kimmeler Silk Mill); Cornelia St and Prospect Ave.; W. H. Rometsch, treas.; F. W. Kimmeler, mgr.; Ribbons; 36 looms; sell direct; F. W. Kimmeler, buyer.
- CASTLE BRAID CO;** 116-136 Troutman St; (S) Henry W. Schloss, pres. M. W. Schloss, treas; Silk, Mohair and Worsted Braids, Buttons and Trimmings; 100,000 spindles; 3000 braiding machines; steam; dye; sell direct; office 556 Broadway, N. Y. Henry W. Schloss, buyer.
- CENTRAL KNITTING CO;** 780 Madison St; (K) High Grade Men's, Boys' and Women's Sweaters, Golf Hose, Knit Skirts and Fancy Knit Novelties; 45 full fashioned knitting machines; sell direct and through agents.
- CHAUBURN & SMITH;** 56 Underhill Ave.; (K) Elastic Stockings; 14 knitting machines; sell direct. (Buy cotton, woolen and silk yarn.)
- CHELSEA JUTE MILLS;** 1155 Manhattan (J) Ave; \$100,000; Geo. D. Pratt, treas; Frank L. Pierce, gen'l mgr; Henry A. Griffin, supt; Jute and Hemp Carpet Yarns, Hemp Carpets, Smyrna Rugs; Jute and Hemp Cordage, Seamless Socks; 250 looms; steam; dye; sell direct; 33 Union Sq, West, New York; Frank L. Pierce, buyer.
- CLINTON MFG. CO;** 83 Grand Ave; John (J) Ross, prop; Flax, Hydraulic and Steam Packings; steam power; sell direct.
- DAVIS & QUICK;** 307-15 St. Marks (D, B, & F) Ave; Dyers, Bleachers and Finishers of Laces, Veilings, Ribbons and Silks; N. Y. office, 495 Broome St.
- DORGEVAL SILK WORKS;** 429-431 So. Fifth (S) St; Dress Silks; sell direct.
- DUNHAM, J. A.;** 294 Graham St; Laces (C) and Edgings; 3 machines; steam; sell direct.
- DUNLAP & Co;** Nostrand and Park (W & S) Aves; \$500,000; A. N. Dunlap, pres; G. C. Henry, treas; C. E. Keator, vice-pres. and supt; Silk Hat Bands; steam; dye; sell direct.
- DUNN, THOMAS L. C. & Co;** 22-24 Mor. (C & J) ton St; Flax, Cotton and Jute Filter Cloths; 8 looms; steam; sell direct.
- EGAN, K. & CO;** 75 Wallabout St; Cotton and Woolen Waste; 3 machines. See Baltimore.
- EMPIRE STATE MILLS;** Wm. Drobnitski, (K) prop.; 123 Middleton St.; Fancy Knit Goods; 11 knitting machines; B. F. Browne & Co., N. Y., s. agts.
- EVERGREEN KNITTING WORKS;** Baldwin (K) Palmer, prop; (Evergreen, Long Island) Cypress Ave; Ladies', Men's and Boys' Sweaters, Bicycle Hose, etc; 10 knitting machines; sell direct. (Buy worsted yarn.)
- FLINDERS, WM;** 127 Railroad Ave; Hand (K) Made Theatrical Knit Goods 4 knitting machines; sell direct.
- FRICKER, HERMAN & Co;** 96-98 Stock. (S) holm St; (N. Y. office, 344 Bowery); Millinery Trimmings.
- FROMM, S.;** 240-244 Broadway; Sweaters (K) and Ladies' and Men's Golf Jackets; sell direct. (Buy 2/16 to 2/20 wool and 6 to 10 qual. worsted yarn.)
- GALLAN, H.;** 108 Meserole St; Woolen (K) Socks and Hosiery; 8 hand knitting machines; sell direct. (Buy worsted yarns.)
- GERNSHYM, HENRY, & BRO;** American (K) Knitting Mills; 36-50 Stockton St; Cardigan Jackets and Sweaters; 150 knitting machines; sell direct, 73 Franklin St., N. Y.
- GOOD, JOHN, CORDAGE & MACHINE CO.;** (J) Bert A. Reiss, receiver; (also Ravenswood) Cordage plant not running.
- GOOD, JOHN & JENNINGS PATENT MA. (J) CHINE CORDAGE CO;** 290-307 Park Ave; \$100,000; John Good, pres; Abraham G. Jennings, treas; S. H. Burns and Chas. Gustafson, supt; Cordage and Binder Twine; steam and electric power; J. L. Witpen, buyer.
- GREENLAND COIR MFG. CO.;** 54 Gold St; (J) \$36,000; W. M. Vanduhoof, treas; Cocoa Matting and Mats; W. & J. Sloane, N. Y., s. agts.
- HARADON, HERBERT H.;** 292 Graham St; (S) Narrow Ribbons; 14 looms; steam; sell direct. (Uses small quantity cotton yarn, 40s, 60s, 80s, 100s, and 120s 2 ply.)
- IMPERIAL KNITTING MILL;** 34 to 40 South (K) First St; A. J. Kelly, prop; Full Fashioned Sweaters, Golf and Bicycle Hose; etc; 25 knitting machines; steam; S. D. Prim e & Co, 48 Essex St., Boston, s. agts. (Buy worsted yarns.)
- JAEGER & WALSHEY;** 19 Fayette St; Mil. (S) lincry and Dress Trimmings, also Specialties in Nettings.
- JENNINGS LACE WORKS;** Abraham (S & K) G. and Albert G. Jennings; Park Ave. and Hall St; \$300,000; Silk Trimmings, Laces, Silk Gloves and Mitts, also Embroideries; 100 sewing machines; 200 other machines; steam and electric; dye; sell direct.
- KALTENBACH & STEPHENS;** Knickerbocker (S) Ribbon Mills; 127 to 137 N. 10th St; 102 Grand St., N. Y.; Otto Suetter, supt.; Narrow Silk Ribbons; 150 looms; steam; F. Viotor & Achelis, s. agts.
- KAYSER, JULIUS, & Co;** 226 Graham St; (K) (office, 467 Broadway, N. Y.); Silk, Lisle, and Cashmere Gloves, Ladies' Swiss Ribbed, Silk, Lisle and Merino Underwear;

- 135 knitting machines; 350 sewing machines; steam; dye; sell direct; Julius Kayser, buyer. (Also Hartford, Conn.)
- KOTLOWITZ, MORRIS;** 97 Varet St.; (**K**) Woolen Hosiery; 18 hand knitting machines; sell direct.
- KREGELOH, H. J.;** 691 Gates Ave.; Skein (**D**) Silk Dyer; steam.
- LANGEL, HENRY.** *Out of business.*
- LIBERTY KNITTING MILLS;** Sam'l Schein. (**K**) delman, prop; 24-28 Boerum St.; Cardigans, Sweaters Bathing Suits, Skirts and Golf Hosiery; 60 knitting machines; 2 looms; steam and electricity; sell direct; 412 Medinah Temple, Chicago, 214 Pine St., San Francisco.
- LONDON KNITTING MILLS;** I. Shaffer, (**K**) prop; 243 Humboldt St.; Wool and Worsted Sweaters; 19 knitting machines; sell direct.
- MENDELSON, HERMAN;** 159 Court St.; (**K**) Woolen and Worsted Sweaters, Cardigans, Vests, Full, Regular and Bicycle Hosiery. (Buy yarn.)
- MOLL, AUGUST, MFG. Co.;** 235 Lynch St.; (**S**) B. Muench, pres; E. Wildfoerster, treas; B. Muench, supt; Dress Braids, Silk, Moha r, Worsted and Cotton; steam; dye; sell direct. (Buy all yarns.)
- MULLER, JULIUS;** 132 Melrose St.; Golf (**K**) Goods and Sweaters; 10 knitting machines; hand power; contract work.
- NARWOOD BROS.;** 942-946 Lafay. (**D, H, I & F**) ette Ave.; Dyers, Bleachers and Finishers of Crimolines, Tarlatan and Netting.
- NASSAU MILLS;** Joseph Wild & Co; 206 (**W**) Kosciusko St.; Geo. Davidson, Jr, supt; Felt; steam; dye; sell direct, N. Y. office, 11 Thomas St.
- NATIONAL BRAID Co.;** Levi & Rice, props; (**S**) 61 Clymer St.; Braids; steam; sell direct; Jos. Levi, buyer; office, 530 Broadway, N. Y. (Buy 26/2 worsted, 24/2 mohair yarn, also cotton yarns of all kinds, silkoline and silk floss.)
- NOLAN, JOSEPH;** 65 Ellery St.; Silk, Spun (**K**) Silk, Worsted and Cotton Theatrical and Sporting Knit Goods; 25 knitting machines; sell direct.
- OSBORNE, M. A.;** 51 Underhill Ave.; The. (**K**) atrical Knit Goods; 25 knitting machines; hand; sell direct. (Buy cotton, woolen and silk yarns.)
- PASS, ADOLPH;** 171-187 Wallabut St.; \$100.-(\$8000; F. B. Crittenden, treas; C. F. Kuehl, supt; Hat Bands and Silk Ribbons; 58 looms; steam; Pass & Co, N. Y., s. agts.
- PEERLESS KNITTING MILLS;** D. Hirschkind, (**K**) prop.; 9-17 Hope St.; Ribbed and Shaker Sweaters, (Men's, Ladies' and Children's) Gloves, Golf Hose and Golf Jackets; 35 knitting machines; steam; sell direct and Rubens & Meyer, N. Y., s. agts.; D. Hirschkind, buyer.
- PERKINS, J. T. Co.;** Hooper St. and Kent (**W**) Ave.; Chas. E. Perkins, pres, and treas; Worsted Yarns and Camel's Hair Press Cloths; 6 combs; steam; sell direct.
- PLANET MILLS MFG. Co.;** Planet Mills; (**J**) Carroll, Bond and President Sts.; (office 335 Carroll St.); \$1,000,000; Wm. Buchanan, pres; Alex. F. Crichton, treas, and gen'l mgnt; Humps, Carpets, Jute Yarns, Twine and Cordage; 9,500 spindles; 50 looms; steam; dye; sell direct; Alex. F. Crichton, buyer. (Buy cotton, 4/8, 2/14.) (Also Wilmington, Del.)
- PROSPECT KNITTING MILLS;** Plate & (**K**) Clark; 408-410 Berry St.; Wool and Worsted Sweaters, Bicycle and Golf Hose, Jerseys Bathing Suits, Cardigan Jackets; 100 knitting machines; 25 sewing machines; electric; sell direct; N. Y. office, 725 B'way; F. H. Plate, buyer.
- RAWITSER, S. & Co.;** 257 Water St.; Flocks (**W**) and Shoddy; steam; dye; sell direct.
- ROSENFELD, M. & Co.;** 24 Broadway; (**S**) Upholstery Trimmings; 26 looms.
- RUDERMAN, R.;** German Knitting Mills; (**K**) 176 Throop Ave.; Woolen and Worsted Sweaters, Jackets, Golf Hose, Sweaters and all kinds of Hosiery; 8 knitting and 3 sewing machines; sell direct. (Buy 2/20 wool and 3/16 and 4 17 worsted yarns.)
- RUDOLPH, OTTO;** 666 Park Ave.; Sweat. (**K**) ers, Cardigan Jackets, Ladies' Waists, Skirts, etc.; hand power.
- SCHAPIRO, Z. & B.;** German Knitting (**K**) Mills; 722 Flushing Ave.; Woolen Socks, Stockings and Bicycle Hose; 16 knitting machines; hand power; sell direct.
- SEIFERT, ERNST;** 32 Arion Place; Golf (**K**) and Fabric Gloves; 20 sewing machines; sell direct.
- SPIERY & BEALE;** 127 King St.; Elastic (**C**) and Cotton Felt Cushions, Etc; steam; sell direct; 39 Union Sq., N. Y.; C. D. Sperry, buyer.
- SPICER BROS.;** 530 Evergreen Ave.; The. (**K**) atrical and Sporting Knit Goods; 32 knitting machines; gas; sell own goods.
- SPIER, S.;** Canadian Knitting Mills; (**K**) Sweaters, Leggings, Caps, Bicycle Hose, etc.; 431 B'way.
- STANDARD KNITTING MILL;** Fred Beutel, (**K**) prop; 101 Suydam St.; Cardigan Jackets, Sweaters, Golf Hose, etc; 18 knitting machines; 6 sewing machines; gas; sell direct.
- STANDARD KNITTING MILLS Co. (Inc.);** (**K**) 5th Ave. and Sterling Pl; \$35,000; C. L. Bruns, pres; P. L. Bakerson, treas.; W. Marlow, vice-pres. and mgr.; Ladies', Misses' and Infants' Light and Heavy Weight Underwear in Cotton, Cotton and Worsted and All Worsted; 65 knitting machines; steam; dye; Bateson & Dowd, N. Y., sole s. agts. (New mill at Germania Heights, ready July 1/02.)
- TEATHER, SAMUEL;** East Brooklyn Knit (**K**) ting Works; 127 Grove St.; Cotton, Woolen, Worsted and Silk Underwear and Theatrical Goods; 12 knitting machines; sell direct.
- TESCHENACHER, WM.;** 250 Myrtle Ave.; (**D**) Dye Silk, Cotton and Woolen Yarns; steam.
- URBAHN, A. & SONS.;** 323 Kosciusko St.; (**S**) Nat. Brand Satin Wire.
- VOGT, WALTER J.;** Union Braiding Works, (**S**) 320 Bridge St.; Dress, Cloak and Millinery Trimmings and Cords; sell direct. (Buys 16/4 black and colored cotton yarn, 30/2 black and colored glazed cotton, 2/14 slack twisted and colored, 2/24 mohair yarn.)
- WALL, WM. F.;** (office 56 South St., N. (**J**) Y.); Manila Sisal, Cordage and Binder Twine.
- WALTER & BELL;** Wythe Ave.; \$75,000; (**J**) John Druyen, pres; Frank Walter, treas; Bags, Bagging, Cordage, Twine, etc; 68 sewing machines; steam; sell direct.
- WATERBURY ROPE CO.;** 130 N. Hill St.; (**J**) (office 69 South St.); James I. Waterbury, pres; Cables and Oil Well Cordage.
- WATT, JOHN C.;** 803 Grand St.; Rag Car. (**W**) pets; 3 looms; sell direct.
- WELCHERT, HERMAN;** 769 Park Ave.; (**K**) Athletic Knit Goods.
- WILD, JOSEPH & Co.;** 206 Kosciusko St.; (**W**) Geo. Davidson, supt.; Upholster and Embroidery Felts; 14 cards; dye; salesroom, 82 Worth St., N. Y. (Also Astoria.)
- WILLIAMSBURG KNITTING MILLS, THE.;** (**K**) N. Siegel, prop.; 202 Varet St.; Sweaters; 30 knitting machines; electricity; sell direct; N. Siegel, buyer.

- WINDSOR KNITTING MILLS;** South First (**K** and Roebing Sts.; John Klenk, supt.; Infants' Ribbed Underwear, Infants' Sacques, Bath Robes and Fan y Knit Goods; 5 looms; 30 knitting machines; electricity; sell direct; John Klenk, buyer. (Buy white woolen yarn, 2/20 to 2/30; worsted, 2/26 to 2/32; French spin, 1/40 to 1/50; Combed Peeler cotton, 1/26 to 1/50.)
- Buffalo.** H.5.
- AMERICAN BUFFALO ROBE CO;** Louis (**W** Viedt, prop. and supt.; Buffalo Fur Cloth, Astrachan, Carriage Robes, Driving Coats, Astrachans and Eiderdowns; 6 knitting machines; steam; dye; sell direct; Louis Viedt, buyer. (Buy worsted rovings, domestic and imported, single 1-5s and 2 ply wool yarn 20 cut, etc., cotton yarn, 6s to 24s.)
- BERNHARD, MORRIS;** Buffalo Fringe Wks; (**S** 457 Washington St; Upholstry Frimings; 18 looms.
- BUFFALO WEAVING CO., THE;** (Chase & (**C** Mathewson); Webs, Halters, Sureingles, Etc.; 12 sewing machines; 55 looms; steam; sell direct; R. C. Mathewson, buyer. (Buy 8/1 to 8/8, 12/4, 16/2, 21/2 skeins and cones; also jute and worsted yarns.)
- BUFFALO WOVEN LABEL WORKS;** 357-361 (**S** Seventh St; O. A. L. Damm, treas; B. H. Smith, mgr; Woven Labels of all kinds; 5 looms; steam; sell direct; B. Hill Smith, buyer.
- BUFFALO BATTING MILL;** W. A. Clemens, (**C** prop.; Batting; 12 cards; steam; sell direct.
- DUFFY SILK CO., THE;** Throwing; etc; (**S** tricity. (See also Fort Plain and Phenix.)
- Camden.** F.13. R. W. & O. RR, E. C. & N. RR, Cazenovia Div.
- CAMDEN KNITTING CO;** W. J. Frisbie, (**K** mgr; Jersey Ribbed Underwear; 150 knitting machines; 75 sewing machines; steam and water; dye; sell direct; 59 Leonard St., N. Y.
- HART & KLETT;** Textile Belt Lace; 1 (**C** loom; water; sell direct. *Not running; for sale.*
- Camillus.** G.11. N. Y. C. & H. R. RR, Auburn Br.
- KEEFER, JEROME MRS. N;** Central Knit (**K** ting Works; Gloves and Mittens; 75 knitting machines; steam and hand power; sell direct; 377 Broadway, N. Y.
- MIDDLESEX KNITTING MILLS;** W. F. (**K** Keefe; Cotton Men's Underwear; 2 sets; 60 knitting machines; water; Porter Bros. & Co., N. Y., s. agts.
- Canajoharie.** H.16. W. S. RR, Buffalo Div; N. Y. C. & H. R. RR, Mohawk Div.
- MOHAWK VALLEY SILK FABRIC CO;** (**S** E. S. Smith, pres; Silk Jersey Cloth, Gloves and Mitts; 6 looms; steam; sell direct; E. S. Smith, buyer. *Not running.*
- Canastota.** G.13. L. V. RR., N. Y. C. & H. R. RR.
- RANDALL, E. E.;** Cotton Half Hose, 176 (**K** needle.
- Candor.** K.11. D. L. & W. RR, Cayuga Br.
- CANDOR BLANKET CO.;** Horse Blankets; (**W** 2 sets; 15 looms; steam and water; dye; sell direct.
- Canton.** B.15. N. Y. C. & H. R. RR.
- CONWAY, R. W.;** Wool Carding and (**W** & **D** Steam Dyeing.
- Capron.** G.14. D. L. & W. RR, Utica Div; N. Y. O. & W. RR, Utica Div.
- CAPRON KNITTING CO.;** *See Utica.*
- UTICA COTTON CO;** \$250,000; W. H. Cloher, (**C** Jr., pres. and treas.; George Brakefield, supt.; All Kinds Light Weight Fabrics, Principally for Converting, Turkish
- Towels and Corduroy, also Hosiery Yarns, White, Mixes and Colors; 13,560 ring and 12,000 mule spindles; 325 looms; steam and water; J. H. Lane & Co., N. Y., s. agt.; W. H. Lohrer, Jr., buyer.
- Carthage.** D.13. R. W. & O. RR, Carthage & Adirondack Div; Utica & Ogdensburg Div; Carthage & Sacketts Harbor Div.
- HOWARD & BUCK;** Riverside Knitting (**K** Mill; M. Howard, supt; Children's Black Ribbed Underwear; 25 knitting machines; steam; dye; F. B. Berlin, 43 Leonard St, N. Y., and C. H. Kentley, Chicago, s. agts.
- Catskill.** K.18. C. M. & C. W. S. RR, Hudson River Div; N. Y. C. & H. R. RR, Hudson River Div.
- MALCOLM KNITTING CO.;** \$190,000; Jos. (**K** Malcolm, pres.; W. E. Thorpe, treas.; Cotton Fleece Underwear and Overshirts; 7 sets; 36 cylinders; 75 sewing machines; steam; dye; James Talcott, 108-110 Franklin St. and Bacon & Co., N. Y., s. agts.; J. Malcolm, H. P. Pettengill and W. E. Thorpe, buyers. (Buy 18s and 22s, white, mixes and colors.)
- WILEY MFG. CO;** Kaaterskill Hosiery (**K** Mills; \$100,000; W. S. C. Wiley, pres. and treas.; Overshirts and Knit Underwear; 11 sets; 57 knitting machines; 120 sewing machines; steam; dye; Porter Bros. & Co., N. Y., s. agts.
- Cazenovia.** G.13. L. V. RR, Cazenovia Div; W. S. RR, Chenango Br.
- CAZENOVIA WOOLEN & FELT CO;** Greene (**W** Bros. *Burned Dec., 1900. Not rebuilt.*
- Chadwick's.** G.14. D. L. & W. RR, Utica Div.
- CHADWICK'S MILLS CO.;** F. U. Stearns, (**C** treas; Geo. H. Norris, agt; T. Mooney, supt; Light Sheetings, Corduroys and Hosiery Yarns; 14,400 spindles; 300 looms; steam and water; A. D. Juilliard & Co., N. Y., s. agts; Geo. H. Norris, buyer.
- UTICA WILLOWVALE BLEACHING CO.;** (**B** & **F** \$250,000; D. N. Crouse, pres.; Chas. B. Rogers, sec. and treas; B. C. Divine, supt; Bleaching and Finishing of all styles of Cotton Fabrics; steam; B. C. Divine, buyer.
- Clark's Mills.** G.14. N. Y. O. & W. RR, Rome Br; W. S. RR, Buffalo Div.
- HIND & HARRISON PLUSH CO, THE;** (**S** \$200,000; Arthur Hind, pres; Herbert B. Harrison, treas; P. W. Copeland, supt; Silk, Seal and Upholstry Plushes; 81 broad and 35 narrow looms; water and steam; dye; sell direct, 175 Broome St., N. Y., president and treasurer, buyers. (Buy 2/10, 2/16, 2/20, 2/26 warps.)
- Clayville.** G.14. D. L. & W. RR, Utica Div.
- EMPIRE WOOLEN CO.;** \$125,000; Granville (**W** Williams, pres. and agt; R. A. C. Smith, treas; J. C. Bailey, supt; Fancy Cassimeres and Worsteds; 15 sets; 84 looms; water and steam; dye; W. H. Rockefeller & Co., N. Y., s. agts; G. W. Williams, buyer.
- Cohoes.** H.18. N. Y. C. & H. R. RR, Troy & Schenectady Br.
- ANCHOR HOSEY MILLS;** North & Doyle; (**K** Geo. H. Stotts, supt; Men's, Women's and Children's Underwear; 10 sets; 100 knitting machines; 120 sewing machines; water; dye; sell direct; N. Y. office, 346 Broadway.
- ATLANTIC KNITTING CO.;** Wool and (**K** Cotton Underwear; 9 sets; 35 knitting machines; 75 sewing machines; water; dye. *Closed.* (Pending settlement of Campbell Estate.)
- CARROLL MFG. CO.;** Fred'k Fleischman, (**C** prop; Cotton Batting and Cotton and Merino Shoddy; 4 pickers; 2 cards; 2 batting machines; 3 garnets, 1 Willow; water; sell direct; Fred'k Fleischman, buyer.

- CLARKE & HOLSAPPLE MFG. CO;** Pacific (K) Hosiery Mills; \$50,000; S. A. Clark, pres.; Peter H. Mooney, supt.; Men's and Ladies' Flat and Fleece Underwear; 4 sets; 1248 spindles; 25 knitting machines; sell direct; pres. and supt. buyers.
- CLIFTON, S. E. & Co;** Capital Knitting (K) Mills; Ladies' and Children's Ribbed Underwear; 20 knitting and 26 sewing machines; water; sell direct; S. E. Clifton, buyer. (Buy yarns, 9 to 24.)
- COHOES DYE WORKS;** Duncan & Bail- (D) lie; Wm. Duncan, supt.; Wm. Baillie, buyer; Dyeing of Raw Cotton and Wool; Dye and Bleach Cloth, in the roll; water; capacity 10,000 pounds per day.
- COHOES KNITTING CO;** \$25,000; M. T. (K) O'Brien, pres. and treas.; Wm. O'Brien, supt.; Knit Goods; 6 sets; 30 knitting machines; 60 sewing machines; water; dye; sell direct
- COMMERCIAL KNITTING MILLS CO;** (K) (operating Enterprise Mills); F. M. Aufessor, pres.; Jonas Barnett, sec. and treas.; M. F. Aufessor, mgr; Men's and Boys' Wool and Cotton Sweaters and Cardigan Jackets; 6 sets; 1848 spindles; 85 hiteh needle machines; water; Wm. Iselin & Co., s. agt.; F. M. Aufessor, buyer. (Branch of Troy mill.)
- CONTINENTAL KNITTING CO;** \$20,000; John (K) A. Bennett, pres.; Wm. B. Clark, treas. and supt.; Knit Underwear; Men's Balbriggan and Fleece Lined; 4 sets; 25 knitting machines; 70 sewing machines; water; dye; sell direct; John A. Bennett, buyer. (Buy yarn, 7 to 46.)
- ELLIS BROS.** *Out of business.*
- EMPIRE KNITTING MILL;** John A. Nut. (K) tall, supt.; Men's and Ladies' Fleece Lined Underwear; 10 sets; 65 knitting machines; 130 sewing machines; water; sell direct; John A. Nuttall, buyer.
- HALCYON MILLS;** Wm. Nuttall & Co. *Out of business.*
- HARMONY MILLS;** \$1,000,000; W. E. Thorp, (C) (New York) pres. and treas.; J. E. Prest, gen. supt.; Print Cloths, Sateens, Sheetings and Grain Bags; 130,000 ring and 140,000 mule spindles; 6550 looms; water; Garner & Co, N. Y., s. agts; J. E. Prest, buyer.
- HIMES UNDERWEAR CO;** Diamond Knit- (K) ting Mills; \$50,000; J. W. Himes, pres. and treas.; Fred S. Perrine, supt.; All Kinds Men's, Ladies' and Children's, Wool, Fleece Lined and Ribbed Goods; 11 sets; 2720 mule spindles; 80 knitting machines; steam and water; dye; sell direct; J. M. Himes, buyer wool; F. S. Perrine, supplies. (Mill at Waterford.)
- HOPE KNITTING CO;** \$100,000; Wm. H. (K) Rowe, pres.; Frances J. Wood Rowe, treas.; Jas. H. Shine, sec. and supt.; Mixed Underwear; 7 sets; 23 knitting machines; 75 sewing machines; water; dye; sell direct and W. H. Rowe & son, s. agts.
- JOHNSTON, DAVID S.;** Orkney Mill; Joseph (K) Moore, supt.; Men's Balbriggan Underwear; 24 knitting machines; 40 sewing machines; steam and water; sell direct.
- KAVANAUGH, F. W. MFG. CO;** Globe Knit (K) ting Mill; \$100,000; G. W. Kavanaugh, pres.; F. W. Kavanaugh, treas.; W. B. Leroy, supt. and buyer; Men's, Women's and Children's Cotton and Wool Fleece Underwear; 4 sets; 50 knitting machines; 125 sewing machines; steam; sell direct and S. P. Burrell & Co., 256 Church St., N. Y., s. agts.
- LOWENTHAL, W. & Co;** Cohoes Shod. (W & C) dy Mill; Cotton Bats; Wool, Merino and Cotton Shoddies and Waste, Custom Picking and Garneting; 6 garnetts; 4 pickers; 5 dusters; water; sell direct; W. Lowenthal, buyer; (also at 18 West First St, Boston.)
- MASSASOIT MILLS.** See Waterford.
- MCDOWELL, G. H. & Co;** Cascade Mills; (K) 346 Broadway, N. Y.; Men's, Women's and Children's Worsted, Wool and Cotton Underwear; 6 sets; 2160 spindles; 64 knitting machines; steam; sell direct; G. H. McDowell, buyer.
- MOHAWK RIVER MILLS;** A. W. Davitt, (K) prop.; Underwear; 7 sets; 25 knitting machines; 40 sewing machines; water. (Buy 7 to 30 yarn.)
- MOORE, WM. KNITTING CO;** Granite (K) Mills; \$50,000; Wm. Moore, treas. and sec.; Wm. Tierney, supt. and buyer; Ladies' and Men's Fine Wool Goods, white and natural; 8 sets; 2080 spindles; 26 knitting machines; 75 sewing machines; water; Muir & Malone, 253 Church St., N. Y., s. agts.
- MOORE & TIERNEY;** Eric Mill; Under- (K) wear; 6 sets; 20 knitting and 22 sewing machines; water; Muir & Malone, 253 Church St, N. Y., s. agts; James Tierney, buyer.
- MURPHY, JOHN H. MFG. CO;** Paris Knit (K) ting Mill; John H. Murphy, pres. and gen'l mgr; James Aitken, treas.; Cotton Ribbed Underwear; 3,000 spindles; 85 knitting machines; water; dye; sell direct; John H. Murphy, buyer.
- NORTHSIDE KNITTING CO.** *Lease cancelled.*
- PAGE MFG. CO;** \$10,000; Joseph Page, (C) pres.; Jonas Ravenscroft, treas. and mgr; Cotton Bats and Shoddies; 10 garnetts; 4 pickers; 1 duster; steam and water; sell direct; E. J. Ravenscroft, buyer. New batting plant; Cotton Bating, Dyeing and Bleaching; 15 cards; 5 pickers.
- PARSONS MFG. CO;** Standard Mill; (K) \$100,000; Samuel Parsons, treas.; M. Orzan, supt.; Woollen and Cotton Underwear; 6 sets; 48 cylinders; 80 sewing machines; water; sell direct.
- PEARL KNITTING MILLS;** John F. Quinn, (K) prop.; cor. Canvass & Cortland Sts; Ladies', Misses' and Children's Cotton Ribbed Underwear; water; sell direct.
- RIVERSIDE KNITTING MILL;** \$125,000; H. (K) Boehlowitz, pres.; W. Buck, sec. and treas.; John Dunlap, supt.; Wool and Cotton Underwear in Flat, Fleece and Ribbed; 10 sets; 2360 spindles; 56 knitting machines; 125 sewing machines; steam and water; W. Buck, buyer; sell direct and Muir & Malone, 253 Church St, N. Y., s. agts.
- ROOT MFG. CO;** Tivoli Mills; \$125,000; (K) A. J. Root, pres. and treas.; Chas. H. Douglas, sec.; All-wool and Merino Underwear; 19 sets; 84 cylinders; water; Wm. Iselin & Co, N. Y., s. agts; president and secretary, buyers.
- STANDARD MILL;** See Parsons Mfg. Co.
- STAR KNITTING CO;** \$200,000; Harriet A. (K) Bolton, pres.; J. N. Lansing, treas.; A. I. Whitehouse, supt.; Men's, Ladies' and Children's Wool, Worsted and Merino Underwear; 9 sets; 2,160 spindles; 40 knitting machines; water; dye; sell direct; 256 Church St., N. Y.; A. D. Whitehouse, buyer.
- THOMPSON, GEO. E.;** Garneting and Cot- (C) ton Bats; 4 pickers, 6 garnetts.
- TROY WASTE MFG. CO;** \$200,000; C. N. (C & W) Fluck, pres.; Peter McCarthy, treas.; Thos. Cocker, supt.; Bats, Waste and Shoddy; 7 pickers; 8 garnett machines; 4 cards; water; dye; sell direct; office 432 River St; Troy.
- UNITED WASTE MFG. CO.** See Troy.
- VICTOR KNITTING MILLS CO;** J. A. (K) Brooks, pres. and treas.; G. P. Gray, sec.; Men's, Women's and Children's Knit Underwear; 15 sets woollen; 5000 spindles; 140 cylinders; 500 sewing machines; steam and water; sell direct; N. Y. office, 51 Leonard St.
- WALKER & HARP MFG. CO;** \$40,000; Hayes (C) W. Walker, pres.; Jos. A. Leggett, treas;

- Alfred V. Walker, supt; Medicated Cotton Batting; steam; bleach; sell direct; Hayes W. Walker, buyer.
- WALKER & WILLIAMS MFG. CO.; (C & H)** \$20,000; Mrs. Rosanna Williams, pres.; David Williams, treas.; Electric Cotton Bats, Custom Garnetting and Bleaching; 13 garnett machines; 7 pickers; water; sell direct.
- Colemans.** (Oneida County.) G-14. N. Y. C. & H. R. RR, Mohawk Div.
- CHRISMAN, W. N.;** (P. O. address, Oris (W. Kan.); Custom Picking; 2 pickers; 2 Garnett machines; water. (Freight address, Whitesboro.)
- College Point.** P-18. L. I. RR, North Side Div.
- COLLEGE POINT SILK DYEING CO.;** R. A. (D. Weber; Dyer of Skein Silk.
- COLUMBIA WEAVING CO.;** (co-partner (S. ship); 24th St. and White Stone Road; Ribbons and Brush Braids; 12 looms.
- GERLACH, A. & Co.;** Dyers of Yarns, (D & F also Dyers and Finishers of all Textile Fabrics.
- MYHNEPO RIBBON MILLS** (P. O. Box 27); (S. Adolphe Openhytu, pres.; Albert Stern, treas.; Emil L. Blum, supt; Silk Ribbons; 150 looms; steam; Wm. Openhytm & Sons, N. Y., s. agts; Emil L. Blum, buyer.
- ROLLE, AUG. J.;** Narrow Silk Ribbons; (S. 67 looms; steam; Oelbermann, Dommerich & Co; N. Y., s. agts.
- WEHRLIN & BRUGGER;** College Point Silk (D. Dyeing Works; Skein Silk Dyers.
- Columbiaville.** (Columbia County.) K-18 N. Y. C. & H. R. RR, Hudson Riv. Div; K. & H. RR.
- EMPIRE YARN MILLS;** Jas. A. Hoyer; (C. Isaac Van Dyck, supt; Cotton Yarns, White and Colored; 6,240 spindles; steam and water. (Supply yarns for knitting mill.)
- HOYER, J. A.;** W. H. O'Brien, supt; (K. Men's White Cotton and Fleece Lined Goods; 3½ sets; 25 knitting machines; water; sell direct; J. A. Hoyer, buyer.
- Cooperstown.** H-15.
- INDEX KNITTING MILLS.** *See Phoenix (K. Mills, N. Y.*
- Cornwall.** N-17. N. Y., L. E. & W., Newburg Junction Br.
- PATENT WOOLEN CO.;** \$5000; Holland (W. Emslie, pres.; Joseph Broadhead, treas. and agt; Horse Blankets, Blanket Linings Duck Coat Linings and Overcoatings; 2 sets; 2 looms; steam and water; dye; sell direct; J. Broadhead, buyer.
- Corona.** P-18. L. I. RR.
- LONG ISLAND BRAID CO.;** Albert (C & W. Jacobs, Otto K. Friedrich, Robt. V. Thompson; All Kinds of Braids.
- Cossayuna.** G-19. 6 miles from Salem.
- ALEXANDER BLANKET CO.;** \$15,000; Wm. (W. Alexander, pres.; J. S. McClellan, treas.; Albanson Tucker, supt; Square Blankets and Blanket Cloths; 2 sets; 15 looms; water; sell direct; J. S. McClellan, buyer. (Buy warps 2/20.)
- Crown Point.** D-19. D. & H. C; C. T. Co.
- CROWN POINT KNITTING CO.;** G. W. (K. Foote, sec. and treas.; Ladies' Ribbed Underwear; 11 knitting machines; water; sell direct. (*Closing out the plant; not doing any business.*)
- Dannemora.** A-18. C. R. R.
- CLINTON PRISON.;** S. Patterson, supt; (Knitting dept. transferred to Sing Sing Prison.)
- Delhi.** K-15. N. Y. O. & W. RR.
- DELHI SILK CO.;** Delhi Silk Mill; W. M. (S. and F. C. Gallant, mgrs.; Broad Silks and Mixed Goods; 100 looms; steam; J. Stern & Co., N. Y., s. agts.
- Dolgeville.** G-15. L. E. & D. RR.
- AMERICAN FELT COMPANY.;** T. H. Roth, (W. supt; Wool Felts for all Purposes, Piano and Shoe Felts, principally; 36 cards; 7 hardeners; water; dye; sell direct. (See New York City for officers.)
- Dryden.** J-11. Lehigh Val. RR, Auburn Div.
- DRYDEN BLANKET MILL, THE.** *See El (W. mira Woolen Co.*
- Eastport.** P-21. L. I. RR.
- ROBINSON, F. JAY.;** Cotton Woven Netting, (C. from Seine Twine; sell direct. (Buys 6, 9, 12, 16 and 20 soft laid seine twines.)
- East Randolph.** K-4. N. Y. P. & O, Eastern Div.
- BUTCHER, F. & SON.;** Woolens; 2 sets; (W. 8 looms; water.
- East Salem.** G-19. D. & H. C. RR.
- GREENWOOD & CLARKE.;** Engleville (W. Woolen Mills; (formerly C. P. Hatch); Men's Wear; 600 wool spindles; 2 sets; 6 looms; water; dye; sell direct. *RR. Station Shushan.*
- Elmira.** K-10. N. Y., L. E. & W. RR, Susquehanna Div; D. L. & W. RR, Buffalo Div; E. C. & N., N. C. RR, Camandaigua Div.
- CALL MFG. CO.;** E. I. Call, agt., supt, and (C. buyer; Supers and Interlinings; 4000 ring spindles; 100 looms; steam; Danforth, Clark & Co, N. Y., Boston, Phila, Baltimore and Chicago, s. agts.; E. I. Call, buyer.
- CONEWASH SPINNING CO.;** Casper G. (C. Decker, pres.; Wm. H. Bilbrough, treas. and supt.; Cotton Yarns; steam; dye; pres. and treas., buyers.
- ELMIRA KNITTING MILLS.;** (Inc.); C. G. (K. Decker, pres.; W. H. Bilbrough, treas. and supt; All Kinds Spring Needle Underwear; 53 knitting machines; steam; dye; Wm. Iselin & Co., N. Y., s. agts.; pres. and treas., buyers.
- ELMIRA WOOLEN CO.;** \$50,000; Blankets; (W. 2 sets; 10 looms; steam and water; dye.
- QUEEN CITY KNITTING MILLS.;** R. G. Jen. (K. nings prop. Ladies', Misses' and Infants' High Grade Cotton Ribbed Underwear; 40 knitting and 75 sewing machines; steam; dye; sell direct and E. M. Townsend & Co, agts.
- READ & LOVATT CO. THE.;** \$200,000; Jer. (S. one C. Read, pres.; J. Walter Lovatt, treas.; Sam'l Thorp, supt. and buyer; Silk Throwing; 4000 spindles; steam; N. Y. office 445 Broome St. (Also see Weatherly, Pa.)
- SUPERIOR KNITTING MILL CO.;** \$100,000; (K. C. E. Bruce, pres. and treas.; Cotton Ribbed Underwear; 100 knitting machines; steam; sell direct; C. E. Bruce, buyer. (Buy cotton and worsted yarn, 8-40.)
- STEARNS, J. N. & Co.;** Broad Silks; 300 (S. looms; steam; N. Y. office 68 Greene St. (Also at Williamsport, Pa. and Petersburg, Va.)
- Ephratah.** G-16. N. Y. C. & H. R. RR, Mohawk Div; W. S. RR, Hudson River Div.
- YANNEY, LEVI.;** Cassimctes, Flannels, (W. Yarns, Pantalones; 3 sets; 9 looms; water; dye; sell direct.
- Esopus.** L-18. W. S. RR, Hudson River Div
- DIMICK, J. W. Co.;** (P. O. address, Rifer (W. Glen); \$250,000; J. W. Dimick, Jr, pres.; J. W. Fitzgerald, treas.; Jos. Jagger, supt; Velvets, Wilton Art Sq. Rugs; 11 sets woolen; 4 worsted cards; 672 spindles; 2 combs (Spindley & Flyer system); 66 carpet looms; water; dye; J. W. Dimick Co, 111 5th Ave, N. Y., s. agts.
- Falconer.** K-4. D. A. V. & P. RR.; E. RR.; G. & J. RR.
- CHAUTAUQUA KNITTING MILLS.;** Hilda (K. Engstrom and A. E. Williams; C. A. Carl-



- son, agt.; Heavy Woolen Socks, Onting Flannel Night Robes and Working Shirts; 5 knitting machines; 1 ribber; 2 sewing machs es steam; C. A. Carlson, buyer (Buy 2, 3 and 4 ply woolen yarn.)
- FALCONER WORSTED MILLS;** \$100,000; (W) Geo. O. Meredith, pres.; Grant A. Forbes, vice-pres.; Alfred Hine, sec. and treas.; Asa Hind, supt.; Medium and Fine Worsted Yarns, single and ply; (Bradford System); 2 cards; 2 combs; 2200 spindles; steam; sell direct; Asa Hind, buyer.
- MEADOWBROOK MILLS;** Wm. Broadhead (W) & Sons, props.; Dress Goods and Yarns; 6 sets woolen cards, 5 combs; 7500 worsted spindles; 40 broad looms; sell direct, 377 B'way, N. Y. (See also Jamestown.)
- Firchcliff.** See West Cornwall.
- Fishkill-on-Hudson.** M-18. N. Y. C. & H. R. RR, Hudson River Div; N. Y., N. H. & H. RR.
- DUTCHESS HAT WORKS;** co. partnership (W) Mrs. Lewis Tompkins, J. Tompkins, R. S. Tompkins and Helen M. Statesbury; John W. Pearl, supt.; Wool Hats; 20-sets; steam and water; dye; C. H. Tenney & Co., s. agts.; R. S. and E. L. Tompkins, buyers.
- Fonda.** G-16. F. J. & G. RR; N. Y. C. & H. R. RR, Mohawk Div; W. S. RR, Buffalo Div.
- CAYADUTTA KNITTING CO.;** Glove Lin. (K) ing, Elderdown, Cloth Gloves; 5 sets; 1500 cotton spindles; 24 knitting machines; steam; dye. *Failed. I. E. Smith (St. Johnsville), trustee.*
- Fort Ann.** F-19. D. & H. RR, Saratoga Div. WALL, E. JR; Men's Ribbed Underwear; (K) 14 knitting and 16 sewing machines; steam; sell direct.
- Fort Johnson.** G-17.
- MORRIS, A. V. & SONS; Mill No. 2; Un- (K) derwear; 6 sets; 24 cylinders; steam and water; dye; Wm. Iselin & Co., N. Y., s. agts. (See Amsterdam.)
- Fort Plain.** G-16. W. S. RR, Buffalo Div; N. Y. C. & H. R. RR, Mohawk Div.
- BAILEY KNITTING MILLS, THE; Chas. (K) Bailey & Sons, props.; Jersey Over-shirts, Cheap Grade of sweaters and Jersey and Astrachan Gloves; 6 sets; 1829 cotton spindles; 60 knitting machines; 50 sewing machines; steam; dye; sell direct; Squire Bailey, buyer. Buy 26 1/2 cotton yarn on cones. (Formerly Fort Plain Hosiery Mills.)
- FORT PLAIN KNITTING CO. formerly (K) Daniel I. DeVoe; \$100,000; Infants', Children's, Misses' and Ladies' Merino Underwear, 15 cylinders; 14 sewing machines; steam; Critten, Clift & Co., N. Y., s. agts.
- DIANA KNITTING MILLS. See Johnstown.
- DEFFY SILK CO. THE; Throwsters; 15. (S) 000 spindles; steam. (Also at Buffalo and Phoenix, N. Y.)
- Frankfort.** G-14. W. S. RR, Buffalo Div; N. Y. C. & H. R. RR, Mohawk Div.
- FRANKFORT LINES MFG. Co. *Out of business.*
- Fulton.** F-11. D. L. & W. RR, Oswego & Syracuse Div; N. Y. O. & W. RR, Northern Div; R. W. & O. RR, Syracuse, Phoenix & Oswego Div.
- FULTON WORSTED MILLS (American (W) Woolen Co.); W. M. Wood, (Boston), treas.; F. E. Weeden, agt.; Wm. Koehler, supt.; Worsteds and Worsted Yarns (French system); 12 combs; 2 sets woolen cards; 14 sets worsted; 22,800 worsted spindles; 296 looms; water and steam; dye; J. Clifford Woodhull, N. Y., s. agt.
- Fultonville.** G-16. W. S. RR, Buffalo Div; N. Y. C. & H. R. RR, Mohawk Div.
- STARIN SILK FABRIC CO.; \$50,000; A. De (K) Graff, pres and supt.; R. L. Craig, treas.; Silk Mitts and Gloves, etc.; 9 looms, 4 rented; steam; dye; sell direct; John H. Starin, N. Y., buyer.
- Garnerville.** N-17. W. S. RR, Hudson River Div; N. J. & N. Y. RR.
- ROCKLAND PRINT WORKS; Jas. A. Rich, (Pr) buyer; Wm. L. Tostevin, mgr; Calico Printing; 20 machines; Garner & Co., N. Y., s. agts.
- Gloversville.** G-17. F. J. & G. RR.
- FONDA, A. V.; Knit Wrists; 16 knitting (K) machines.
- FULTON COUNTY SILK MILLS; (S & K) Cromme Holmes & Holmes, props., 233 Kingsboro Ave.; Geo. Holmes, supt. and buyer; Silk Gloves and Silk Linings for Leather Gloves; 3 looms; 3 knitting machines; steam; sell direct. Buy silk 14 1/6 tram, 20/22 raw.)
- GLOVERSVILLE FELT CO.; \$25,000; G. (W) Levor, pres.; J. H. Filmer, treas.; John Pendergast, supt.; All Kinds of Felt Goods; 4 sets; steam; dye; sell direct; John Pendergast, buyer.
- GLOVERSVILLE KNITTING CO.; \$100,000; (K) L. N. Littauer, pres; C. W. Stewart, treas.; E. C. Collins, mgr; Knit Wool Gloves and Faced Mittens; 100 knitting machines; 3 sets; steam; dye; sell direct. (Also Oneonta.)
- GLOVERSVILLE SILK MILLS; C. D. Noyer, (S) pres. and agt.; A. M. Barker, treas.; Silk Gloves and Combination Gloves, also Silk Mitts; 6-14in. English looms; 60 sewing machines; steam; dye; sell direct.
- GLOVERSVILLE TEXTILE CO.; 51 East (S) Fulton St.; Silk and Mercerized Linings for Kid Gloves; 6 looms; gas engine; sell direct; J. T. Shanahan, buyer.
- KINGSBORO DYE WORKS; Robert Loven- (D) stein, prop.; 460 N. Main St.; Silk, Wool and Cotton Fabrics; Silk Glove Linings a Specialty.
- PECK, FRANK L.; Knit Mittens. (K)
- Green Island.** H-18. D. & H. RR, Saratoga Div; N. Y. C. & H. R. RR, Troy and Schenectady Div.
- GREEN ISLAND KNITTING MILLS; Isaac (K) Roff; Ribbed, Fleece Lined and Balbrigan Underwear; 65 cylinders; 135 sewing machines; steam and water; dye; sell direct and Muir & Malone, N. Y., s. agts. (Buy 6s to 30s yarn.) (P. O. address, Troy.)
- Greenwich.** G-19. G. & J. RR.
- DUNBARTON FLAX SPINNING CO; H. D. (F) McMaster, pres; J. W. Wallace, treas; Jas. Bright, supt; Linen Thread, Twine and Yarn; steam and water; dye; The Linen Thread Co., s. agts.
- GROAT, CHARLES C.; Pleasant Vale Mills; (K) Edwin Groat, supt; Fleece Lined Underwear, Men's, Ladies' and Boys', and Over-shirts; 10 sets; 2480 silk spindles; 62 knitting machines; water and steam; dye; Bacon & Co. and Jas. Talcott N. Y., s. agts. Buy 22 cotton yarn on cones in mixtures and white.)
- VAN ZILE KNITTING CO.; \$60,000; Jesse (K) V. Palmer, pres; M. C. Rowe, treas; Ladies' and Misses' Ribbed shaped Underwear; 21 knitting machines; steam and water; sell direct. Buy 9 to 11 carded Peeler and Egyptian, cops and cones.)
- Hagaman's Mills.** G-17. N. Y. C. & H. R. RR, Mohawk Div; W. S. RR, Buffalo Div.
- ANCHOR KNITTING MILLS; L. E. Har- (K) rower, prop; Men's Knit Underwear; 7 sets; 40 knitting and 75 sewing machines; steam and water; dye; Day & Kenyon, N. Y., s. agts. (Also Amsterdam.)
- STAR HOSIERY MILLS; L. E. Harrower; (K) Mixed Underwear and Top Shirts; 10 sets; 50 knitting cylinders; 37 sewing machines; steam; dye. (Also Amsterdam.)

- Harrison.** O-18. N. Y., N. H. & H. RR.  
**MANHATTAN BRAID WORKS;** Fred (C & S Empeper, prop.; Silk, Lisle and Cotton Suspender Braids; 100 braiding and 6 sewing machines; steam; sell direct.
- MOOSEHEAD SILK CO.;** F. W. Korth, mgr. *Burned Jan., 1902.*
- Haverstraw.** N-18. N. J. RR, Haverstraw Br.; N. Y., O. & W. RR.  
**HAYERSTRAW DYEING CO.;** \$50,000; G. (D) Kowes, mgr.; Skein Silk Yarn Dyers. N. Y. office, Room 508, Silk Exchange.
- HOME SILK MILLS;** E. & A. Balthasar. (S) props; Mr. Gossweiler, supt.; Broad Silks; 300 looms; steam; E. Molson, with H. A. Caesar, N. Y., s. agt.
- Herkimer.** G-15. N. Y. C. & H. R. RR, Mohawk Div; M. & M. W. S. RR, Buffalo Div.  
**BROOKS MFG. CO.;** \$15,000; Cyrus Kay, (K) Jr., pres.; Duane M. Richardson, treas.; M. W. Brooks, sec. and mgr.; Sweaters. (Operating Gen Knitting Co.'s mill.)
- GEM KNITTING CO.** *Out of business.*
- MACK, EVERETT & CO.;** Albany St.; (K) Fine Hosiery; 8 knitting machines; electricity; dye; sell direct.
- MARK MFG. CO.;** \$55,000; J. Howard Mark, (K) pres.; N. P. Murphy, treas.; All Wool Sweaters and Knit Underwear; 10 sets; 100 knitting machines; steam and water; dye; sell underwear direct and sweaters through E. M. Townsend & Co., N. Y. (Buy 18, 24, 30 white cotton yarns.)
- MILLER, Guy H.;** Ladies' Ribbed Under. (K) wear.
- Highland Mills.** N-17. N. Y., L. E. & W. RR, Newburgh Br, short cut.
- HALL, HENRY;** Linen, Silk and Cotton (S & J) Fish Lines, Twines, Etc.; 2500 spindles; steam and water; dye; sell direct.
- Homer.** H-12. D. L. & W. RR; Syracuse, Binghamton & N. Y. RR.  
**NEWTON & Co.** (co-partnership); Homer (W) Woolen Mills; D. D. Newton, supt.; Flannels; 1 set; 8 looms; steam and water; dye; sell direct; D. D. Newton, buyer. (Buy cotton warps on beams, 28 and 40.)
- Honeoye Falls.** G-8. N. Y. C. & H. R. RR, Rochester Br; L. & H. F. RR.  
**HUNT'S WOOLEN MILL;** A. H. Hunt, (W) prop.; Cassimeres, Carriage Cloth and Flannels; 2 sets; 4 broad and 4 narrow looms; steam and water; dye; sell direct.
- Hoosick Falls.** H-19. B. & M. (Fitch) RR.  
**FALLS KNITTING CO.;** \$15,000; Louis (K) Haussler, pres.; Francis Riley, treas.; J. H. Mecker, mgr.; Balbriggan Underwear. (In plant formerly occupied by Superior Mfg. Co.)
- HOOSICK FALLS HOSIERY CO.;** \$30,000; (K) H. T. Smith, treas.; Thos. B. Wilson, supt.; Cotton, Wool and Merino Ribbed Goods; 3 sets; 40 knitting machines; 50 sewing machines; steam; dye; Chas. A. Brown & Co., Troy, s. agts.
- SUPERIOR MFG. CO.** *Out of business.*
- Hornellville.** J-8. N. Y., L. E. & W. RR, Buffalo Div; C. N. Y. & W. RR.  
**LIBERTY SILK CO.;** (Branch New York (S) City); John Dimond, supt.; Dress Silks; 225 looms; steam; Wm. Schroeder & Co., s. agts.; John Dimond, buyer. (In building vacated by Rockland Silk Mills.)
- MERRILL FIELD & Co.;** F. P. Merrill, buyer; (S) Chiffons; 222 looms; steam; dye; sell direct; 55 Franklin St., N. Y.
- ROCKWELL, & ROCKWELL;** (successors (K) to Rockwell, Merrill & Rockwell); Silk Gloves and Mitts; 6 knitting machines; 75 sewing machines; dye; sell direct; 55 Franklin St., N. Y.
- STEBEN SILK CO.;** \$6,000; M. W. Wal- (S) dorf, pres.; Chas. R. Phillips, sec. and treas.; J. A. Moss, supt.; Taffetas, Peau de Soie, Satin and Veilings; 85 looms; sell direct.
- Hudson.** K-18. B. & A. RR, Hudson & Chatham Br; N. Y. C. & H. R. RR, Hudson River Div; K. & H. RR.  
**BEAVER KNITTING MILLS;** \$100,000; F. (K) H. McCormick, pres.; John W. Carlos, treas.; Raymond B. Fuller, sec.; J. B. Terwilliger, supt.; Fine Jersey Ribbed Underwear, Overshirts a Specialty and Mattress Batting; 9 sets; 70 knitting machines; steam; dye; sell direct.
- HARDER MILL;** Union Knitting Co.; W. (K) Frank Holsapple, mgr.; John Hearn, supt.; Men's Fleece Lined Underwear 9 sets; 76 knitting machines; steam; dye; sell direct; 99 Franklin St., N. Y.
- Hudson Fibre Co.;** \$25,000 Henry Hud- (W) son, pres. and treas.; Chas. H. Hudson, mgr.; W. H. Kennedy, supt.; Wool and Cotton Shoddies, Custom Work and Cotton Bats; 1 burr picker; 1 waste puller; 5 rag pickers; 10 garnett and 2 bat machines; 2 dust-ers; carbonizing; steam; dye; sell direct; Chas. H. Hudson, buyer. (Also dealers in Cotton and Wool Stock.)
- UNION KNITTING CO.;** \$100,000; W. (K) Frank Holsapple pres. W. F. Holsapple, treas. and mgr.; John Hearn, sec.; Wm. H. Hearn, vice pres. and supt.; Fleece and Merino Knit Underwear; 16 to 24 gauge; 10 sets; 60 knitting machines; 130 sewing machines; steam; sell direct; 99 Franklin St., N. Y. (See also Harder Mill.)
- Hion.** G-15. N. Y. C. & H. R. RR, Mohawk Div; W. S. RR, Buffalo Div.  
**STERLING MILLS;** \$30,000, W. K. Jenne, (K) pres.; E. G. Wood, treas. supt.; and buyer; Worsted Jerseys, Bathing Suits and Wool Sweaters; 960 spindles; 2 sets; 22 knitting machines; 10 sewing machines; steam; dye; sell direct.
- Jamestown.** K-4. J. & L. E. RR; N. Y., L. E. & W. RR, Buffalo & Southwestern Div; N. Y., P. & O. RR, Eastern Div.  
**AHLSTROM-ASHWORTH CO.;** Tops; (W) Combing. (To add spinning and drawing machinery.)
- ASHWELL, E. J. & Co.;** Foote Ave; Lisle (C) Thread; do not spin; buy cotton yarn; sell direct and Holland & Webb, N. Y., s. agts.
- BROADHEAD WORSTED MILLS;** Wm. (W) Broadhead & Sons; S. B. Broadhead, supt.; Women's Dress Goods and Men's Worsteds; 9 worsted cards; 8900 worsted spindles (Bradford system); 12 combs; 500 looms; steam; dye; sell direct; N. Y. office 377 Broadway; firm buyers. (See also Falconer.)
- CHAUTAQUA TOWEL MILLS;** Preston & (C) Mackey; \$250,000; Linen Union and Turkish Towels, Terry, Cloth, etc.; 30 narrow looms; gas; sell direct; (buy 14/1 single and 20/2 ply cotton warps, 88 to 128 cops for filling)
- CHAUTAQUA WORSTED MILLS;** (co-part- (W) nership); Worst ed Yarns and Tops, all numbers; 7 worsted cards; 5 combs; (English system); 5000 spindles; steam; sell direct; Fletcher Goodwill, buyer.
- EMPIRE WORSTED MILLS;** \$250,000 (W) J. W. Doubleday, pres. and buyer; L. M. Butman, treas.; E. Greenwood, supt.; Dress Goods and Suitings; 5 worsted cards; 4 combs; (English system); 4000 worsted spindles; 150 looms; steam; dye; sell direct and H. Sanders & Co., 256 Church St., N. Y., s. agts. (Buy cotton warps and skins, 2/12-2/208, 2/308, 2/408 and worsted warps 2/328 to 2/408.)

**FALCONER TOWEL CO;** \$5,000; F. Hitehner, (C pres. and supt; H. W. Davis, treas.; Turkish Towels, Wash Cloths, Bath Sheets, etc.; 22 looms; steam; bleachery; sell direct; J. W. Davis, buyer.

**INGHAM, JOHN, & Co;** \$10,000; Wool Bat. (W) ingham and Yarns; 30 ring and 220 mule spindles; 1 set; steam; sell direct; John Ingham, buyer.

**JAMESTOWN COTTON MILLS;** Thos. H. (C) Smith; Warps and Skeins, 30-40 single and two folds, Battings 28" wide for comforters and Upholsterers, extra quality; 8064 spindles; steam; sell direct and Wilson & Bradbury, Phila., s. agts.; T. H. Smith, buyer.

**JAMESTOWN WOOLEN MILLS;** Hall & Co; (W) Howard Corning, supt; Cassimeres and Flannels; 3 sets; 24 looms; steam and water; dye; sell direct; Sam'l Briggs, of the Jamestown Worsted Mills, buyer.

**JAMESTOWN WORSTED MILLS;** Hall & Co; (W) Samuel Briggs, supt; Dress Goods and Suitings; 9 sets; 14 combs; 500 looms; steam; dye and finish; sell direct; Sam'l Briggs, buyer.

**Johnstown.** G-16. F. J. & G. RR.

**DIANA KNITTING CO, THE;** (Inc.); suc. (K) cessors to Diana Knitting Mills; \$100,000; Geo. Veghte, pres. and treas.; Mr. McElwain, supt.; Men's and Women's Ribbed Winter, Men's Summer Ribbed and Balbriggan Underwear; 44 knitting machines; steam; A. D. Juilliard & Co., s. agt.

**JOHNSTOWN KNITTING CO;** \$60,000; Martin (K) Kennedy, pres.; Jas. L. Younglove, vice-pres. and sec.; E. M. Kennedy, treas.; Men's, Ladies' and Children's Fleece Lined and Men's Fancy Balbriggan Rib Underwear; 40 knitting machines; steam; W. H. Rowe & Son, N. Y. s. agts.; W. S. Van Brocklin, buyer.

**ROYAL KNITTING CO;** Gloves and Mittens, Seamless Gloves Linings and T. Backs; 41 knitting machines; steam; dye; sell direct.

**Kenwood.** K-13. N. Y. O. & W. RR.

**ONEIDA COMMUNITY (LTD.);** \$600,000; T. R. Noyes, pres.; J. S. Freeman, treas.; H. E. Joslyn, supt.; Machine Twist and Sewing Silks; steam and water; dye; J. H. Noyes, buyer; N. Y. office, 413 Broadway.

**Kinderhook.** J-18. K & H. RR.

**COLUMBIA KNITTING MILL CO, THE;** (K) Isaac Metstein and Imoud Vener; Gloves, Mittens, Sweaters, Leggings, Toques, Stockings, etc.; 20 knitting machines.

**KINDERHOOK KNITTING CO;** \$10,000; F. B. (K) Van Alstyne, pres.; J. A. Reynolds, treas.; F. S. Hoag, supt.; Wool and Worsted Mills, Equestrian Tights, Leggings, Toques and Children's Cotton Waists; 80 knitting machines; 15 sewing machines; steam; sell direct, and Roger Lamson Co, N. Y. s. agts.; F. B. Van Alstyne, buyer. Buy yarn 8 to 36.

**LINDENWALD MILLS.** (See Poughkeepsie.)

**Lausburgh.** See Troy.

**Lepshire.** K-12. D. L. & W. RR, Buffalo Div.; Erie RR, Susquehanna Div.

**FAATZ FELTING CO, THE;** Eagle Felting (W) Mills; (formerly Faatz Brush & Felting Co); \$45,000; W. G. Faatz, pres. supt. and buyer; G. H. Faatz, treas.; Woolen Felts; 12 sets; steam; dye; sell direct.

**Little Falls.** G-15. L. E. & D. W. S. RR, Mohawk Div.; N. Y. C. & H. R. RR, Mohawk Div.

**ASTORONGA KNITTING MILLS;** See Gilbert Knitting Co.

**ELBOEUF KNITTING CO;** See Union, N. Y.

**GILBERT KNITTING CO.** (successors to K the Astoronga Mills and Little Falls Knitting Mills Co); \$200,000; J. J. Gilbert, pres;

Elijah Reed, treas.; Geo. Dise, supt; Underwear; 14 sets; 181 knitting machines; 366 sewing machines; steam and water; dye; Day & Kenyon Co, N. Y. s. agts.

**HUDSON BROS;** Shoddy, Custom Pick. (W) ing, Garnetting and Burring; 3 pickers; 2 garnetts; 2 dufters.

**LITTLE FALLS WOOL EXTRACT CO;** Geo. (W) L. Smith, supt; Wool Extracts and Shoddy; 5 sets; steam; dye; sell direct; Geo. L. Smith, buyer.

**MACKINNON, ROBT;** B. Mac Kinnon, (K & C) supt; Ladies', Men's and Children's Underwear; 11 sets; 16,369 rim 2 spindles; 250 knitting machines; steam; dye; sell direct; N. Y. office, 343 N. Y. Life Bldg.

**ROCKTON KNITTING MILLS;** Whitman (K) Bros; James Henry, supt.; Gents' Underwear, and Men's and Boys' Sweaters; 4 sets; 50 cylinders; 55 sewing machines; water; dye; se l direct.

**SHEARD CO, TITUS;** Eagle Mills; \$80,000; (K) Titus Sheard, pres; Frank senior, treas.; E. N. Spore, supt; Knit Goods; 13 sets; 3565 mule spindles; 71 knitting machines; 86 sewing machines; steam; dye; sell direct.

**VICTOR KNITTING MILL CO.;** S. A. Bisler, (K) pres. and treas.; Victor Adams, mgr.; Victor Adams, Jr., supt.; Ladies' Cotton Ribbed Underwear; 108 knitting machines; 110 sewing machines; steam and water; dye; sell direct, L. W. Lynt, 904 N. Y. Life Bldg, N. Y., representative; F. H. Burrows, buyer.

**WALRATH, RUGENE;** Riverside Knitting (K) Mill; Men's and Boys' Balbriggan Underwear, Men's and Boys' Fleece Lined Underwear; 32 knitting machines; steam and water; dye; sell direct. (Buy 6 1/2 to No. 40 yarn.)

**Lockport.** G-5. N. Y. C. & H. R. RR, Lockport Br; N. Y. L. E. & W. RR, Lockport Br

**EMPIRE MFG. Co;** Owen Howerth, supt; (C) Cotton Belting, Cotton Rubber Lined Hose Narrow Goods of all descriptions, surgical Elastic Supporters, Bandages; 51 looms; steam and water; sell direct; firm, buyers. (Buy 8/3, 8/8, 14/2, 16/2, 18/2, 16/3, 26/2 yarns.)

**LOCK CITY LAMBS' WOOL BATTING CO;** (W) M. M. & Fred Anderson; Wool Batting and Wadding.

**NEW YORK COTTON BATTING CO;** Cotton (C) Batting; 40 machines; steam; sell direct.

**NIAGARA COTTON BATTING CO;** (Inc.); Jas. (C) Cochran, pres; W. E. Cochran, sec. and treas.; W. J. Cochran, supt; Cotton Batting, Wadding and Comfortables; electric; sell direct. W. E. Cochran, buyer.

**NIAGARA TEXTILE CO;** J. A. Hoag, (C & F) pres.; W. T. Ransom, treas.; Huck Towels and Crashes; 48 looms; steam; sell direct; W. T. Ransom, buyer. (Buy warps 10s and 16s and tow yarns. 10s, 11s and 25s.)

**NORMAN & EVANS;** John Morris, supt.; (W) "Golden Fleece" Wool Wadding, 4 sets; 1 picker; 1 cleaner; water; sell direct and Wm. T. Stearns, 377 Broadway, N. Y. s. agt.

**PETTIT & Co;** Cotton and Wool Uphol. (C) stery Tufting; steam; dye; sell direct; W. M. Pettit, buyer. (Buy coarse cotton, wool and cotton wick.)

**ROGERS, E. W. & SONS;** Lockport Cotton (C) Batting Co; Bats; 12 cards; steam and water.

**Long Island City.** F-18. L. I. RR; L. I. & R. B. RR.

**ASTORIA SILK WORKS;** \$200,000; Jac. Rup. (S) pert, Jr, pres; C. C. Mattmann, treas; Piece Dyed Silks, Velvets and Plushes; 550 looms; steam; dye. Buy cotton yarns in skeins and on cops. (Also branch at Unionport, N. Y.)

- INGRAM, DAVID; EST. OF; Dyer of and (D Dealer in Cotton Yarn. (See Astoria.)
- Madrid.** A-14. C. V. RR, Ogdensburg & Lake Champlain Div.
- MADRID WOOLEN MILLS; \$34,000; A. D. (W Whitney, pres. and treas.; Cassimeres, Etc.; 2 sets; 5 looms; steam and water; dye; sell direct. *Not running.*
- Malone.** A-17. C. V. RR, Ogdensburg & Lake Champlain Div.; M. & M. RR, St. Lawrence & Adirondack Div.
- MALONE WOOLEN MILLS; J. O. Ballard (W & Co; G. A. Wilson, supt; Wool Tweeds and Trousers; 2 sets; 7 looms; 15 sewing machines; water; dye; sell direct.
- LAWRENCE WEBSTER CO., THE, \$120,000; (W D. W. Lawrence, pres. and treas.; J. F. Wright, agt. and supt.; All Wool Cassimeres; 3 sets; 14 looms; steam and water; sell direct; J. F. Wright, buyer.
- Marcellus.** G-11. N. Y. C. & H. R. RR, Auburn Br.
- CROWN MILLS; \$150,000, Edward Moir, (W pres.; A. T. Sullivan, (N. Y.) treas.; J. M. Moir, supt. and buyer; Woolen Men's Wear; 15 sets; 76 looms; steam and water; dye; Sullivan, Vail & Co. N. Y., s. agts. (2 mills.)
- Marlboro.** M-18. W. S. RR, Hudson River Div.
- SUTCLIFFE BROS.; Carpet and Rug (W Yarns; Garnetted Stock; 2 cards; 2 garnett machines; steam and water; sell direct.
- Maspeth.** P-18. L. I. RR.
- CATING, JAMES; Wm. B. Cating, prop. (J Manila and Sisal Cordage, etc.; 44 spindles; steam; D. P. Winne Co., 338 Broadway, N. Y., s. agts.
- HAFFLINGER, GUSTAVE; Cordage, Twine, (J Etc.
- Matteawan.** M-18. N. D. & C. RR; N. Y. & N. E. RR, Western Div.
- ELLRODT, C., JR. & J. H. LYNCH (form. (S erty A. V. Rockwell); Silk, Tram and Org. ganzine Throwster; 8000 spindles; steam and water.
- MATTEAWAN MFG. CO.; \$150,000; C. R. (W Henderson, pres; Norman Henderson, treas.; Wool Hats; 20 sets; steam and water; dye; sell direct; Wm. Read & Co, Searle, Dailey & Co, N. Y., s. agts; N. Y. office, 64 Cedar St.
- McDonough.** J-E. (Not shown on map.) RR. station, Greene, D. L. & W. RR.
- STOTT, A. J.; Woollens and Hosiery; (W & K 1 set; 4 looms; 3 knitting machines; water; dye.
- Mechanicsville.** H-18. D. & H. RR, Saratoga Div.; F. R. RR, Western Div.
- KNICKERBOCKER HOSIERY MILLS; New- (K land & Neilson; Chas. Whitman, supt; Mixed Underwear; 5 sets; 21 knitting machines; steam and water; A. D. Juilliard & Co. and Muir & Malone, s. agts. W. B. Neilson, buyer.
- MECHANICSVILLE KNITTING CO.; \$50,000; (K E. H. Strang, pres. and supt; Geo. Rogers, treas.; Men's Cotton, Wool, Flat and Fleece Lined Goods, also Men's Bathrighans; 4 sets; 40 knitting machines; steam; Day & Kenyon Co, 260 Church St, N. Y., s. agts; E. H. Strang, buyer.
- SAGAMORE KNITTING CO.; \$100,000; (succes. (K sors to Tenandaho Knitting Co); Henry Newland, pres; H. McKie Wing, vice pres; H. J. Russell, sec. and treas; Fleeces and Flat Wool Underwear; 6 sets; 39 cylinders; steam; Coolcy, Turnbull & Co., N. Y., s. agts.
- WITBEK & CUNNINGHAM BROS.; (W & C Woolen and Cotton Shoddies; Dyeing, Picking, and Garnetting; 1 picker; 2 dusters; 2 garnetts; steam; dye; J. W. Witbeck, buyer and s. agt.
- Mellenville.** K-18. B. & A. RR, Hudson & Chatham Br.
- PITCHER, A. P. Co; \$40,000; A. P. Pitcher, (K pres; Horatio A. Allen, treas.; E. B. Skinner, supt. and buyer; Men's Jersey shirts and Underwear; 4 sets; 20 knitting machines; steam and water; dye; sell direct. (Buy cotton and worsted yarns.)
- Middletown.** N-16. N. Y. S. & W. RR; N. Y. O. & W. RR, Southern Div; N. Y. L. E. & W. RR, Eastern Div.
- WALKHILL HAT WORKS; Wool Hats; (W steam; dye.
- Middleville.** G-15. M. & M. RR.
- NELSON KNITTING CO.; \$10,000; A. W. Nelson, sec. and treas.; A. W. Nelson, mgr.; Men's and Boys' Overshirts; 4 sets; 1300 cotton spindles; 26 cylinders; steam and water; dye; Converse, Stanton & Co., N. Y., s. agts.; E. J. Nelson, buyer. (Buy no. 12-18-20 cones.)
- Milton.** M-18. W. S. RR, Hudson River Div.
- BELL'S, HENRY H. SONS CO; \$150,000; 704 (K Broadway, N. Y.; W. M. Bell, pres; Arthur B. Sinclair, treas; Arthur E. Bell, supt; Eiderdowns, Glove Linings, Stockinet Garments; A-strachan, Bouclé, Bathing Suits, Etc; 40 knitting machines; steam; dye; sell direct; 337 B way, N. Y.; Arthur E. Bell, buyer. (Buy yarns, 2/23, 4/15, 3/14.)
- Mohawk.** G-15. W. S. RR, Buffalo Div.; N. Y. C. & H. R. RR, Mohawk Div.
- MOHAWK VALLEY KNITTING MILLS, THE (K LTD); \$50,000; J. B. Rafter, pres. and treas.; W. P. Brayton, mgr. and buyer; Men's, Ladies' and Children's Underwear, Natural and Camels-Hair Wool; 7 sets; 50 cylinders; 2100 spindles; 75 sewing machines; steam; dye; Critten, Chift & Co., N. Y., s. agts.
- PARAGON KNITTING CO, THE; \$110,000; (K B. A. Stone, pres; J. B. Rafter, treas; W. P. Brayton, mgr; Men's, Ladies' and Children's Wool Underwear; 8 sets; 38 knitting and 78 sewing machines; steam; Critten, Chift & Co., N. Y., s. agts.; W. P. Brayton, buyer.
- Montgomery.** M-17. N. Y. L. E. & W. RR, Montgomery Br; W. Y. RR.
- CRABTREE & PATCHETT; Worsted Yarns (W in Gray, Colors and Mixtures; (Bradford system); 6 combs; 4 worsted cards; 23 sp. frames; steam and water; dye; sell direct; Wm. Crabtree, buyer. See Newburgh.
- Moodna.** N-17. Via West Cornwall.
- PATENT WOOLEN CO; see Cornwall.
- Mumford.** G-7. B. R. & P. RR, Rochester Div.
- O. A. T. KA WOOLEN MILLS. *Shut down; machinery sold.*
- New Brighton.** S. I. P-17. Staten Island RR, Erastha Div.
- IRVING MFG. CO; \$200,000; Wm. Irv. (C & K ing, pres; John Irving, treas; Converters' Linings and Tarlatans; also Seamless Cotton Hosiery; 68 knitting machines; steam; dye; sell direct, 111 Franklin St, N. Y.
- Newburgh.** M-17. N. Y. L. E. & W. RR, Newburgh Br; W. S. RR, Hudson River Div; N. D. & C. R. RR.
- CRABTREE & PATCHETT; Worsted Yarn, (W spinning only); 16 spinning frames, each 168 spindles; steam; finishing machinery. Also Montgomery.
- CRAWSHAW, CO, THE; Carpets and Smye. (W na Rugs; 4 sets; 73 looms; steam; dye; Rugs, H. B. Claffin & Co, N. Y., s. agts. A. Y. Weller, receiver. (Carpet machinery not running.)
- HARRISON & GORE; Jas. Harrison, pres; (S E. E. Gore, vice pres; F. J. Harrison, Jr, treas; James Harrison, Jr, sec; Broad

- Silks and Specialties; 190 looms; steam and water; S. S. Butler, 82 Green St, N. Y., s. agt.
- HUDSON RIVER WOOLEN MILLS:** \$50,000; (W) Moses Mendelsohn, pres; S. Mendelsohn, treas; L. F. Gillespie, supt; Shirtings, Suitings and Dress Goods; 6 sets; 20 broad and 60 narrow looms; steam and water; dye; Mendelsohn & Co, 20 White St, N. Y., s. agts; S. Mendelsohn, buyer.
- LACKEY, G. E. O.:** Curtains, Laces, etc. (C)
- NEWBURGH BLEACHERY:** \$150,000; (B) & (F) Jos. Chadwick, pres.; Thomas F. Chadwick, treas.; Jos. Chadwick & Sons, agts.; Wm. E. Chadwick, supt.; Bleaching and Finishing Cottons; steam and water; Jos. Chadwick & Sons, buyers.
- NEWBURGH STEAM MILLS:** \$100,000; W. E. (C) Thorn, pres.; Oscar Huss, treas.; H. B. Beckun, act. and supt.; Print Cloths; 12,300 ring and 13,250 mule spindles; 610 looms; steam; Garner & Co, N. Y., s. agts.
- NEWBURGH WOOLEN MILLS:** Foster & (W) Taylor; R. A. Foster, supt; Plush Lap Robes, Moquettes and Plain Plushes; 8 sets; 42 looms; steam and water; dye; S. Stroock & Co, N. Y., s. agts; Jas. S. Taylor (partner) and R. A. Foster, buyers.
- STANDRING, JAMES E.:** Shoddy and (W) Custom Picking; 1 picker; water; sell direct.
- STROOCK FELT CO;** Louis S. Stroock, (W) pres; Mark E. Stroock, treas; W. J. Moorehouse, supt. and buyer; All kinds of Felts; 10 sets; steam and water; dye; S. Stroock & Co., s. agts.
- Newfane.** P. 5. R. W. & V. RR, Western Div.
- LOCKPORT FELT CO;** \$25,000; C. T. Ray, (W) mod. pres. and treas.; Chas. H. Morgan, agt.; Joseph Robinson, supt.; Paper Makers' Felt and Machinery Cloth; 2 sets; 3,200 wool spindles; 5 looms; steam and water; sell direct; Joseph Robinson, buyer.
- Newfield.** J. H. L. V. RR, Ithaca Br.
- MOOD, A.:** Domestics; 1 set; 3 looms; (W) water; dye.
- New Hartford.** G. H. D. L. & W. RR, Utica Div; N. Y. O. & W. RR, Utica Div.
- ARMSTRONG, BAKER & CO.** Failed. Property sold and may be started again.
- NEW HARTFORD COTTON MFG. CO;** \$150,000; John W. MacLean, pres; Jas. Harris, treas. and supt.; Light Cotton Goods; 10,176 ring spindles; 260 looms; steam and water; sell direct; James Harris, buyer.
- OLYMPIAN KNIT GOODS CO.;** \$40,000; Ed. L. (K) Wells, pres.; D. L. Davies, treas. and mgr.; John W. Bryce (72 Leonard St., N. Y.) agt.; Sweaters, Golf Hose, Cotton and Worsted Bathing Suits, Cardigan Jackets and Jerseys; sell direct.
- Newport.** G. J. M. & M. RR.
- NEWPORT KNITTING CO;** \$30,000; Titus (K) Sheard, pres.; O. N. Purdy, treas.; Frank Senior, agt.; Ribbed Underwear; 45 knitting machines; water; dye; Critten, Clift & Co., N. Y., s. agts. (Buy cotton yarns from 88 to 208, carded and combed.)
- SMITH, D. W.:** Newport Hosiery and (K) Mitten Mill; Bridge St.; Fine Cotton and Wool Half Hose, Gloves, Sweaters and Mittens; 20 knitting machines and 1 sewing machine; steam. *Closed. For sale.*
- NEW YORK.** P. 18.  
See also Brooklyn.
- AMERICAN THREAD CO;** 260-266 West (C) Broadway; T. M. Ives, sec. and treas. Branches: Glasco Yarn Mills, Glasco, Conn.; Willimantic Linen Co, Willimantic, Conn.; Kett Thread Co., Fall River, Mass.; Hadley Co. and Merrick Thread Co., Holyoke; Morse & Kaley Mfg. Co., Milford, N. H.; Wm. Clark Co., Westerly, R. I.
- AMERICAN FELT COMPANY;** \$3,250,000; (W) H. H. E. 13th St; Chas. L. Lovering, (Boston), pres.; William B. Goodwin, treas.; William S. Armstrong, sec.; Felts of all Descriptions and Woolen Goods. Manufacturing plants at City Mills, Mass.; Dolgeville Mill, N. Y.; Essex Mills, Pictou, N. S.; Franklin Mills, Mass.; Glenville, Wills, Conn. (Purchasing dept. does all the buying for the several mills.)
- ADAMS KILMARX CO, THE;** 186-188 Wood (S) ter St; Ladies' Dress, Cloak and Millinery Trimmings, Cords and Tassels; steam.
- ADHESIVE GIMP CO;** Kellogg & Gage, (S) propos.; 405-409 E. 91st St.; \$8,500; A. J. Wallace, supt.; Upholstery Gimps; 15 looms; steam; sell direct; C. M. Kellogg, buyer.
- ALTSCHULER, LEON;** 15 Elizabeth St; (S) Silk Cover Wire.
- AMERICAN MFG. CO;** 65 Wall St; \$1,800,000; (J) Benj. B. Graham, pres; L. F. Jones, treas.; W. W. Childs, sec.; C. J. Norris, mill mgr. and buyer-supplies; Cordage, Twine, Jute Baggings. (Mills at Brooklyn, N. Y., and St. Louis, Mo.)
- AMERICAN NOVELTY PRINTING & (P) D & P EMBOSSEMENT WORKS;** John McCowan, prop; 413-415 West Broadway; Embossing and Printing on Silks, Satins, etc; also dye ribbons.
- AMERICAN SILK DYEING & FINISHING (D) CO;** 52 Howard St. (See Hawthorne, N. J.)
- AMERICAN SILK LABEL MFG. CO.;** 2608. (S) 3618 Park Ave; Geo. Hey, mgr; Woven Silk Labels and Trimmings; 100 looms; steam; sell direct; 461-467 Broadway.
- ARLINGTON EMBROIDERY WORKS;** 129 (S) Thompson St; Henry Sturm, mgr; Embroideries and Novelties; 30 machines; sell direct.
- ARNOLD, A. & CO;** 457-461 West Broadway; (S) Dress and Millinery Trimmings; 45 looms.
- ASCHER, SIMÉON;** 411-413 Wooster St; (K) Knit Zephyr Goods.
- ATLAS SWISS EMBROIDERY CO.;** 546 E. (S) 157th St. (office 50 E. 84th St.); Dress Trimmings and Novelties; 12 Swiss embroidery machines; sell direct; Chas. Spiro, buyer.
- ATLAS SILK CO.;** 525 W. 54th St; Fred (S) Wasserman, supt; Ribbons; 40 looms; steam; Wm. Iselin & Co, s. agts.
- BANDMAN & HELFMANN;** 175-177 Wooster (S) St; Dress and Millinery Trimmings and Novelties; 15 knitting machines; sell direct.
- BANK, A. M.;** 105 Mercer St; Silk Wind. (S) ing and Reelin g.
- BARRETT, NEPHEWS & CO;** Old Staten (D) Island Dyeing Est; 334 Canal St; \$25,000; Hy. B. Palmer, pres; Chas. E. Heal, sec; Chas. W. Kennedy, supt; Dyers; Henry B. Palmer, buyer.
- BARRETT, PALMER & HEAL;** 346 Canal (D) St; factory, Nordhoff, N. J.; Dyers and Finishers, Woolens, Worsted, Dress Goods, Silks; steam; dye.
- BARTON, F. C.;** 54-56 Franklin St; (C & S) Narrow Fabrics, Ribbons, Tapes and Bindings for the Manufacturing Trade.
- BENNETT, ADOLPH;** 115 Mercer St. (S) Dress, Cloak and Millinery Trimmings.
- BERLIN & Trosky;** 127-133 Bleecker St; (S) Silk Covered Wire and Hat Cord.
- BERNSTEIN, MITCHELL B.;** 315 E. 103rd St; (S) S. Witte, supt; Ribbons and All Narrow Silk Fabrics; 50 looms; electricity; sell direct; M. B. Bernstein, buyer.
- BERNSTEIN & CO;** 111 Mercer St; Silk (S) Trimmings, Cords, etc; 14 hand looms; sell direct; Mr. Bernstein, buyer.
- BLAIR, S. H.;** 359 Canal St; Upholstery (S) Trimmings.

- BLUM, NICHOLAS; 165th St, near Brook (D Ave); Skein Silk Dyer.
- BLUMENTHAL, A. & S.; See Shelton, Conn. (S)
- BOESEN, WM. J.; 29 Mercer St; Fringes, (S Cords, Tassels, Etc; 12 looms; sell direct.
- BOETGER & HINZE; 500 Broome St; Silk (F Finishers.
- BOLTON, ROBT. B. *Out of business.*
- BOWMAN, D. J.; 110 East 169th St.; (K Ladies' Hosiery, Black and Mercerized; 6 knitting machines; sell direct.
- BRANDT, JOS. & Bro; 98 Wooster St; (S Dress, Cloak and Millinery Trimmings.
- BRAUNSTEIN, SAMUEL; 363 Canal St; (S Dress, Cloak and Cap Trimmings.
- BRIGHT MILLS. See Passaic, N. J.
- BRILLIANT SILK CO. See Paterson, N. J.
- BRONX CO; 1 7th St and Bronx (Pr O & H1 River); (office, 108 Worth St; W. H. Bireh-ell, pres; W. H. Bolton, sec; hos. Bolton, Jr, treas, and agt; Cotton Printers, Dyers, Bleachers and Finishers.
- BRUNNER & DRIEFUSS; 49 44 Canal St; (S Swiss Embroideries and Laces.
- BUSCHMANN, C. H.; 5 Howard St; Dress (S and Cloak Trimmings, Fringes, Cords, Tassels, etc.
- CATOIR SILK CO; 212-232 W. 26th St; \$70.- (S 000; John Catoir, pres; Chas. Bormmann, treas; Broad Silks; 140 looms; steam; sell direct; C. Bormmann, buyer.
- CHARAVAY & BODVIN; 174-182 Worth (F St; Silk Finishers; capacity, 600 pieces a day; steam; sell direct
- CHEGNAY, HENRI CO; Bank and Hudson (D Sts; Dyeing, Printing and Finishing all Textile Fabrics.
- COHN, H.; 25 Howard St; Embroidery; (S 10 machines; sell direct.
- COLUMBIA HOSIERY CO; Winona Mills; (K 1355 Park Ave; \$60,000; J. A. Simonds, treas, and gen'l mgr; Ribbed, Plain and Seamless Hosiery; 140 knitting machines; steam; sell direct.
- CORNELL, THOS. L.; 146 Wooster St; (F Cloth Refinisher.
- CRESCENT CO.; \$50,000; W. W. Beebe, (K pres, and treas.; High Grade Sweaters and Bathing Suits; 20 knitting machines; sell direct.
- DEUTSCH, CHAS; 534 E. 87th St. office; (K 538 E. 87th St., mills; Henry Murke, supt; Knitted Webbing for Incandescent Gas-light Mantles; 36 plain and 10 rib knitting machines; steam; dye; sell direct; Louis Deutsch, buyer.
- DROSIN, D. & SONS; 229 E. 4th St; Bicycle (K and Golf Stockings, Sweaters, Cardigans, etc; 20 knitting machines; electricity; sell direct.
- DREYFUSS, JULIUS & Co; 22-26 East 14th (S St.; Bonnaz Embroideries and Dress Trimmings; 10 looms and 60 braiding machines; sell direct.
- EAGLE NOVELTY WORKS; 49 Crosby St. (Pr Embossing, Watering and Printing.
- EAGLE SILK CO; 615-625 W. 52nd St; \$25.- (S 000; Hans Hurliman, pres; Fritz Bricket, treas; Alfred C. Wall, agt; Fritz Bickel, supt, and vice pres; Ribbons; 75 looms; steam; Fleitmann & Co, N. Y. s. agts.
- ECONOMY HAND KNIT WORKS; 276 Church (K St.; Fancy Knit Goods and Novelties, all hand work; sell direct.
- EICKE, EDWARD; 157 Canal St; Millinery (S and Cloak Trimmings.
- ELBERG, A.; 126 East 3d St; Hosiery; 4 (K knitting machines.
- ELLISSON, A. S. & Co; 105 Greene St; (S Fringes, Cords, Tassels, Etc; 24 looms; steam; sell direct.
- EMPIRE FRINGE CO; 210 Canal St; M (S H. Sacks, prop; Window Shade, Fringes and Novelties; 11 looms; steam; sell direct; M. H. Sacks, buyer.
- FASHION KNITTING CO; M. Miller, p. 3, 3, (K 531 Fifth St; Sweaters, Hosiery, Golf Hose, etc; 13 knitting machines; hand power.
- FILER, J. A. & Co, 310-318 Sixth Ave; Up- (S holstery and Drapery Trimmings; 14 hand looms; sell direct.
- FIRTH & FOSTER CO; Silk Exchange. (D & F See Phila
- FISHER, M; 471 Broadway; Dress and (S Cloak Trimmings, etc; 16 looms; 6 sewing machines; steam.
- FLECK, JOHN W; Manhattan Cloth (F Sponging and Refinishing Works; 19 Bond St.
- FLESCII, C; Columbia Knitting Works; (K 425 Broadway; Hand Knit Worsteds.
- FOOT KNITTING CO., THE; 240 Sixth (K Ave; office, 172 West 23rd St.; H. Cannon and A. R. Northrup; Knitting Feet on Worn Stockings, also repairing Cardigans, Bicycle Jackets, etc; 2 knitting machines and 2 sewing machines.
- FRANK, R. 41 Mercer St; Hand Knit (K Worst-ed Goods; sell direct.
- FREYBERG BROS; 108 Wooster St; Skirt (S Bindings, Trimmings.
- FULTON BAG & COTTON MILLS; 236-238 (C Spring St; Equipping building to manufacture all kinds of Bags. (See Atlanta, Ga.)
- GAVIS, WM. E.; 406 Broadway; Embroid- (S ery; 30 embroidery machines; sell direct.
- GERSTENSANG, JACOB; 177 1/2 E. 87th St; (S Ribbons and Carriage Lace, Hat Bands, Passmeneneries, etc.; 4 looms; steam. (Buy 40s, 50s, 60s silk.)
- GLOBE CLOTH EXAMINING, SPONGING (F AND REFINISHING WORKS, S. Brill & Bro, prop; 154-156 Grand St.
- GRANDJEAN, A. N.; 97 Sixth Ave; Fine (S Upholstery and Drapery Trimmings.
- GRAW & LEHMANN; 206 Centre and 138 (S Baxter St; Braids, Braided Buttons and Cords; 250 braiders; steam; sell direct; L. Graw, buyer.
- GREEN, C.; 25 Howard St.; Dress and (S Cloak Trimmings.
- GREENBLATT, L. *Out of business.*
- GREENBERG & LAEGER; 208 Canal St (S and 49 Crosby St; Cotton and Silk Wind-ling and Silk Covered Bonnet Wire.
- GROSSENBACH & VAN NOSTITZ; 141-145 (S Wooster St; Novelty Braid Mill; Braids, Cords, etc; 550 braiders; sell direct.
- HALL, CHAS. H.; 1945 Park Ave; Theatrical (K and Sporting Goods of all kinds and Elastic Hosiery; cotton, worsted and silk; 30 knitting machines; Steam.
- HART, THE A. H. CO; Elm Flax Mills; (J 550-56 West 57th St; John Hinde, pres; James Livingston, vice-pres; James F. Hinde, sec. and treas.; Twine, shoe Thread, Carpet and Upholstery Yarn; 3000 spindles; dye.
- HAUPTNER, L. D.; 521-523 W. 45th St; (K Curtain Materials and Piece Goods; 5 knit-ting machines; steam.
- HAYES, MORGAN C. (successor to T. F. (S Hayes); 28 Union Sq.; Dress Trimmings for the trade.
- HAYNER, GEO. M.; 546 W. 57th St; Fibre (J Twines and Cord.
- HELMUS, G.; 124 W. Huston St.; Cords and (S knitting machines; sell direct.
- HENSHELL BROS.; 617-625 W. 52nd St.; (F Finishers of Broad Silks.
- HEPNER & HORWITZ; 30 Howard St; (C Fred Fettig, supt; Silk and Cotton Cords, Lacings; steam; Mr. Horwitz, buyer,

- HERTLEIN, C. E.**; factory, E. 148th St. cor. (S) Brook Ave; office, 15 Mercer St; Fringes, Dress Trimmings and Ribbons; 30,000 braiding spindles; 130 looms; steam.
- HERZIG, L. & Co.**; 113 Prince St; Hand (K) Made Knit Goods; sell direct; L. Herzig, buyer.
- HIGGINS, D. A. & Co.**; 631-635 W. 130th St.; (D) John Burns, supt; Braids, Worsted, Mohair and Genappe Yarns; and Worsted zephyrs.
- HIGGINS, E. S.** CARPET CO. Consolidated with Hartford Carpet Co, Thompsonville, Conn., which see.
- HIMBERG, J.**; 135 Bowery; Upholstery (S) and Dress Trimmings, Fringes, Cords; 7 looms.
- HOFFSTADT, WM.**; 125 Greene St; Hand (K) and Machine Knit Goods; 14 knitting machines; sell direct.
- HOFMANN & ELLRODT**; 109 111 Spring St; (S) Braids, Cords and Tassels.
- HOLLMANN & SELLMANN**; 167-169 Wooster (S) St; Silk Ribbons; steam; sell direct.
- HOLSTEIN, S.**; 366 W. Broadway; Dress (S) and Cloak Trimmings.
- HOOF & MATTER SILK DYEING CO.**; 333- (D) 335 West 44th St; Silk Dyeing.
- HYGIENIC FIBRE CO.**; 570-576 W. Broad. (K) way; \$30,000; T. C. Asplund, pres.; H. A. Harwood, sec.; Ed. Hammann, treas.; Sanitary Napkins and Supplies; Cotton Bats, etc.; 8 cards; 1 loom; 10 knitting and 3 sewing machines; steam. (Buy 20 cotton cones.)
- INDUSTRIAL SEAMLESS HOSIERY MILLS.** (K) Home of Refuge, Randall's Island; O. V. Sage, supt; Seamless Hosiery; 250 knitting machines; Roger Lamson & Co, N. Y., s. agts.
- INSON, THOS.**; 310 Broadway; Satins, (S) Satin and Picot Ribbons, Cords, Tassels, etc; electricity; sell direct.
- ISKIYAN, HARCUNNE**; 42 Franklin St; Car- (W) pets, List Felt and Rag; 8 hand looms; sell direct. (Also carpet weavers' supplies.)
- JABURG, FUHS & LOVIN**; 115 Wooster St.; (K) Infants' Wear.
- JOHNSTON & Co.**; 3 Lispenard St; Cotton (C) Cable Cord and S. I. Twine.
- JONAS, WM. & Co.**; Braids and other (C) articles pertaining to the line; 50,000 braiding spindles; steam; sell direct; William Jonas, buyer.
- JUNG & TURNBULL**; 106 Grand St; Dress (S) and Cloak Trimmings.
- KAATZ, T. & Co.**; 101-103 Thompson (C & S) St.; T. Kaatz, supt. and buyer; Silk, Cotton and Mohair Braids; 1500 ring spindles; 250 braiding machines; steam; sell direct; T. Kaatz, buyer. (Buy 20s, 30s, 40s, 42s yarns.)
- KAUFMANN & SCHRADER**; 171-173 Wooster (F) St; Cloth Sponging and Refinishing Works; steam.
- KAUFMAN, S. Co.**; (formerly Kaufman & (S) Rosenthal); 496 Broome St; Millinery and Dress Trimmings.
- KAYSER, JULIUS & Co.** See Brooklyn. (K)
- KLAHRE, HUGO**; 124-126 W. 35d St; Cords, (S) Trimmings, etc; 28 looms.
- KNAPP & LOWENTHAL**; 73-75 West Hous- (S) ton St; Dress and Cloak Trimmings.
- KOHN, SAM'L S.**; 366 W. Broadway; \$5000; (S) Chas. Levy, supt; Bonanz Embroidery, Trimmings and Novelties; electric; sell direct.

# Fabric Measuring and Packaging Co.

Postal Telegraph Building, Broadway and Murray Street, New York, U.S.A.



OUR MACHINES PRINT TRADE MARKS

ON COTTONS, WOOLENS, CARPETS (Single and Double Widths.)

We lease and license our machines to measure and imprint the measurement upon fabrics, fold the same lengthwise and roll into merchantable packages all in one operation.

PAID UP LEASES ISSUED.

- KRAUSE, R. & SON; 215 Greene St; Em- (S) bossed Ribbons; 40 machines; 550 cylinders; sell direct.
- KRESSE, F. C.; 206 Canal St; Braids; 200 (S) braiding machines.
- KREUSSER, & BUSCHER; 509-511 W. 45th (D) St; Silk Dyers and Refinishers; steam.
- KURSCHEEDT MFG. CO, THE; 356 W. Broad- (S) way and 143 W. 19th St; \$50,000; Fred A. Kurshedt, pres; Alphonse H. Kurshedt, treas; Chas. D. Williams, sec; Laees, Ruchings, Embroideries, Braids, Velvets, Dress Trimmings, Skirt Bindings, Neckwear, etc.; 65 looms; 2,000 braiding machines; 525 sewing machines; steam.
- LAWSON, A. M.; 2611 Broadway; Suspend- (K) sory Bandages and Surgical Goods.
- LEITER, J. H.; 9 Bethune St; Furniture (S) Gimps; 12 looms.
- LEONE & FIMPEL; 427-429 W Broadway; (S) Tassels, Fringes, Dress Trimmings; steam; sell direct.
- LEVY, E. & H.; 53 Greene St; Mill at 524 (S) W. 55th St; A. L. Davis, supt; Ribbons; 156 looms; steam; sell direct.
- LEVY, STEEEL CO; Columbia Knitting (K) Mills; 67-69 Bleecker St.; Bernard Levy, pres; Ernest A. Grunsfeld, treas; Sweaters, Cardigan Jackets, Golf Hose, Bathing and Athletic Suits, etc.
- LIBERTY SILK CO; 548 W. 57th St; office, (S) 469 Broome St; \$600,000; H. A. Van Liew, pres.; John Lever, Jr., sec. and treas.; E. F. Post, agt; Dress Goods; 400 looms; steam; Wm. Schroeder & Co., N. Y., s. agts. (Also Hornellsville.)
- LION SILK CO; 166 West End Ave.; (office, (S) 52 Grand St.); \$25,000; Ad. Rusch, pres; I. H. Escher, treas; J. C. Strenli, supt; Dress Silks; 216 looms; steam; Abegg & Rusch, N. Y., s. agts.
- LIPPMANN, ISRAEL; Manhattan Knitting (K) Mills; 68-70 Elm St; Wm. Levin, supt; Sweaters, Cardigan Jackets, Golf and Bicycle Hose; 50 knitting machines; electricity.
- LIPS, JOSEPH W. & CO; 167 Wooster (D&F) St; Cloth Refinisher and Sponger; steam.
- LOEWENSTINE, J. H.; 513 Broadway; (K) office, 75 Greene St; Silk Mitts and Gloves; 32 knitting machines; dye.
- LOTH, JOS. & CO; 1830 Amsterdam Ave.; (S) Howard A. Crampton, supt; Silk Ribbons; 87 looms; steam; sell direct; 65 Greene St.
- LUPPERIAN, CHAS.; 345 W. Broadway; (K) Cardigans, Sweaters, Etc; 20 knitting machines; electric power; Hinchman, Vezin & Co., N. Y., s. agts.
- MANDEL, GEO; 109-111 Sumner St; Braids, (S) Cords, Moulds and Trimmings; steam; sell direct.
- MANHATTAN BACKING CO; 140 Sullivan (C&S) St; Vestings, Silks, Velvets, etc. Backed and Sized; also manufacture Ribbons and Trimmings.
- MANHATTAN BRAID WORKS. *See Harrison.*
- MANHATTAN WORSTED MILLS; 608 W. (W) W. 89th St; (Pitkin, Holdsworth Co, Passaic, N. J.); Worsted Yarns, (English System.)
- MARTIN, CHAS. N. Co; 348 Canal St; Wind- (S) ing, Reeling and Spooling; 6 spoolers
- MARTIN, THOS. & CO; 548 W. 46th St; Silk (S) Covered Wire.
- MAUL, H. & CO; 19 Bond St; Silk Dress (S) Trimmings, Braids, Cords, Etc; 18 looms; steam; sell direct.
- MAUPAI, F. P.; 587 Hudson St; Silk Yarn (S) Dyer.
- MAYER, W. H.; 104 Walker St; Ribbon (D) and Silk Waterer, Silk and Crepe Embosser; electricity.
- MCCOWAN, JOHN; 413-415 W Broadway; (P) Silk Piece Printing and n bossing.
- MCDUGALL, JOHN W; 417 and 419 W. (D) 24th St; Dyer of and Dealer in cotton Yarns.
- MENDELSON & GOLDSTEIN; 210-212 Canal (S) St; Braids, Cords and Moulds; 450 braiding machines.
- MERCHANTS' PRINT WORKS; Johnson & (P) Bemis; 414-418 W. 14th St; Printing Satinets and Woolen Goods; 8 printing machines; steam.
- METZGER, LOUIS, & Co; 637 Broadway; (S) and 206-208 Mercer St; Millinery Ornaments and Novelties.
- MEYER, MARTIN & Co; 142 Grand St. (suc- (S) cessors to Kammann & Meyer); Upholstery Trimmings and Fancy Goods; gas engine.
- MORRISIANA SILK MILLS; 703 East 166th St. (S) \$150,000; E. Richard Walter, pres; M. Walter, treas; Organzine, Tram and Ribbons; 150 looms; steam; Pollock & Meminick, 478 Broome St, s. agts.
- MÜLLER, MRS. J.; 127 Grand St; Millinery (S) Trimmings; 20 looms; gas power; sell direct.
- NATIONAL KNITTING MILLS; 430 Broome (K) St.; Sweaters, Cardigans and Bathing Suits; 16 knitting, 5 sewing machines; sell direct; D. Rheinauer, buyer. (Buy woolen and worsted, 2/15-2/16 staple numbers.)
- NEIMAN'S, M. SONS; Harlem Knitting (K) Mills; 124th St. and Columbus Ave.; Geo. Neiman, treas.; Fancy Knit Woolen Goods; 30 looms; 35 knitting machines, steam; sell direct; Geo. Neiman, buyer.
- NEIDORFER & HOCHBAUM; 456 Broome (S) St; Dress and Cloak Trimmings.
- NEW YORK BRAID CO; 101 Thomp. (S & W) son St; Silk and Mohair Braids; 10,000 spindles; 125 braiding machines; sell direct.
- NEW YORK CARPET LINING CO; R. J. (C) Hoguet, pres; Carpet Lining, Stair Pads, etc; sell direct; 308 East 95th St.
- NEW YORK CORDUROY MILL; M. Weyers, (C) prop.; \$10,000; 513 E. 91st St.; A. Weyers, mgr.; High Grade Corduroys, Plushes and Kindred Textile Fabrics; 12 looms; steam; sell direct. (Buy 32 ply, 42 ply, 20s, 30s, 40s yarn.)
- NEW YORK KNITTING MILLS; Thompson (K) & Corbett, 507 W. 50th St; Ladies' Rib-Underwear; 30 knitting machines; 35 sewing machines; Critten, Chitt & Co., s. agts. (Buy cotton yarn 10 to 18.)
- NEW YORK SILK CONDITIONING CO; 30-32 (D) Varriek St; \$20,000; Robt. J. Hoguet, pres, and treas; F. S. Havens, supt; Testing Textile Fabrics.
- NEW YORK, T. & C. Co; 29 Howard St; (S) Silk Cord, Fringes, etc.
- NEW YORK TEXTILE CO; J. B. Sharp; 230 W. (C) 30th St; Elastic Webs; 82 looms; steam; sell direct; J. B. Sharp, buyer. (Buy cotton and silk yarns.)
- NEW YORK WATERING CO; A. (D&F & P) Zulzbach, prop; 72 Wooster St; Redyeing, Finishing, Printing and Moire of Silk Ribbons.
- NEW YORK WOVEN LABEL MFG. CO.; (S) 262 Canal St; Woven Labels; 24 looms; electric; sell direct.
- OHLE & BROEKER; 537-539 Broadway; (S) Dress and Cloak Trimmings, Embroideries; steam; sell direct. A. C. Ohle, supt, and buyer.
- OPPER, H. L. & BROS; 584-586 Broadway; (S) Dress Trimmings.
- ORIENTAL WEAVING Co.; Weller & Richel, (S) props.; 13 East 17th St.; Silk Curtains and Mattings; steam; sell direct.
- OSTERMOOR & Co; 116 Elizabeth St; (W) Patent Elastic Felt.



- PATENT CLOTH SPONGING AND REFINISH. (F) ING CO; Thos. L. Cornell, prop; 146-148 Wooster St; London Finishing a Specialty.
- PERIN, H. O. & Co; 427 Broome St; Up- (S) holstery Fringes and Drapery Trimmings.
- PERSIAN RUG MANUFACTORY; 167th St. (W) and Brook Ave; (office 898-900 Broadway); \$50,000; Robert Stuntz, pres.; Giles Whiting, treas.; Persian Hand Made and Whole Chenille Axminster Rugs in one piece made especially to order; steam; dye.
- REES & REES; 232 E. 40th St; Dyers (D & F) and Refinishers.
- REICHMAN, WM; Germania Knitting (K) Works; 440-444 Canal St; S. Newman, supt.; Cardigan Jackets and Sweaters; 129 knitting machines; steam; sell direct; N. Y. office, 98 Franklin St; S. Newman, buyer.
- RESHOWER, JOS. & Co; 79 Spring St; (S) Trimmings, Fringes, Etc; steam; sell direct.
- RIEGELMAN & Co; (formerly Chas. S) Wimpfeimer; 21 and 23 Howard St; Dress and Cloak Trimmings.
- RIVERSIDE KNITTING MILLS CO; 407 413 (K) East 91st St; \$10,000; S. B. Wallenstein, pres.; O. Gans, treas.; Ladies' Knit Underwear; 25 knitting machines; steam; Bateson & Dowd, 116 Franklin St. N. Y. s. agts.
- ROSENFELD & JONAS; 108-114 Wooster St; (S) Braids, etc. 50,000 spindles; steam; sell direct; Mr. Rosenfeld, buyer.
- ROSENFELD & CO.; 87 Warren St.; Sweat- (K) ers and Cardigans; 25 knitting machines; J. H. Conover, N. Y. s. agt.
- ROTHSTEIN, N.; 114 E. 14th St; Silk, Cot- (S) ton, Mohair and Worsted Braids; 250 braiders.
- SACKS, MEYER H.; Fringes; sell direct (S)
- SALMON, WM; 136-138 Greene St; Dress (S) Trimmings, Silk and Cotton; 10 hand looms; sell direct. (Also Westfield, Mass.)
- SANFORD NARROW FABRIC CO; 9-13 Mercer (C) St; Feather stitch Braids and Fancy Tapes; 100 looms; steam; sell direct. (Buy No. 10/2 to 140/2 yarns.)
- SCHANZER, S.; 190-192 Greene St; Fancy (K) Knit Goods; 60 hand and power knitting machines; sell direct.
- SCHATTMAN, COHN & HESSEL. *Out of business.*
- SCHAUL'S, JULIUS'S SON; 546 Southern (S) Boulevard; Neckwear Silks; 25 looms.
- SCHETTER, A. & S.; 208 Greene St; Dress, (S) Cloak and Millinery Trimmings; 4 looms; 2 knitting machines; sell direct. S. Scheuer, buyer.
- SCHENDELMAN, L. M.; Rosenhayn Knit- (K) ting Mills; 211 E. 4th St; Hand Made Sweaters, Bicycle Hose, etc; 40 knitting machines. (Also at Rosenhayn, N. J.)
- SCHIESS, THEO; 75-77 Spring St; Trim- (S) mings.
- SCHMID, F. J.; 540 E. 157th St; Coach (C & S) Laces, Carriage Trimmings, Cords and Tassels; 22 hand looms; gas engine. (Buy 168, 308, 498, two ply soft cotton in all colors.)
- SMITH & BEYER; successors to E. D & F) Bader; 517-519 W. 45th St.; Dyers, Finishers, Waterers and Blockers of Ribbons.
- SCHNITZLER B; 304 Elizabeth St; Braids, (S) Cords and Moulds; 700 braiders; steam.
- SCHURMANN, FRED'K; 291 Monroe St; (S) Dress and Cloak Trimmings; 8 looms.
- SCHWARZ & STERN; 42 E. Houston (C & W) St; Worsted, Cotton, Silk, Mohair and Gold Braids; steam; L. L. Stern, buyer.
- SECKEL, M. & Co; 15 Mercer St; Dress and (S) Cloak Trimmings.
- SIMON, ERNEST B; 166 E. 123rd St; Cords (S) and Fringes.
- SLOANE'S, JAMES, SONS; West Farms; (W) Carpets and Rugs; 27 looms; steam; dye; sell direct.
- SMITH & CHOFFIN; 525 W. 24th St; Silk (F) Finishers.
- SMITH & KAUFFMANN; 559 W. 132nd St; (S) I. Hellman, supt; Ribbons; 200 looms; steam; sell direct; office 102 Prince St.
- SPEKING'S, E. M. SONS; 713 Broadway; (S) Woven Labels; steam; sell direct; J. E. Sperling, buyer.
- STANDARD THREAD CO. 35 Downing St; (C) Spool Cotton for Manufacturing Trade.
- STAR RIBBON MFG. CO; 224 Centre St; (S) \$60,000; Henry Kamule, pres.; Solomon Gottschall, vice-pres; Bruno Richter, sec; Ribbons, Hat Bands and Corset and Underwear Trimmings; 60 looms.
- STARR, HYMAN; Starr Knitting Works; (K) Park Ave and 130th St; Shaker Knit Sweaters; steam; sell direct.
- STEINBERG & RAWITZER; 156 Centre St; (S) Braids and Trimmings; 120 braiding machines.
- STEINHARDT, C. 22 Bond St; Cords and (S) Tassels; sell direct.
- STEINTHAL, L. & Bro.; Atlantic Knitting (K) Mill; 537 Broadway; Knit Goods.
- STIFFSOX, SAMUEL J; 137 West 23rd St; (S) Cords, Fringes, Upholstery Trimmings and Tassels.
- STUMPF & SCHWARTZ; 350 W. 44th St; (D) Silk Skein Dyeing; steam.
- STURZENEGGER, EDM; 604 E. 157th St; (S) office 611-621 Broadway; Silk Embroideries; 25 machines.
- SUMMIT SILK COMPANY; (office 492 Broome (S) St.); Broad Silks. (Bought Sxmes Bldg. and remodelled same, at West New York.)
- SUNDBEIMER BROS; 33-35 Greene St; Dress (S) and Cloak Trimmings; 20 looms; 10 knitting machines; steam; sell direct.
- SUTRO BROS. BRAID CO; 404 W. 27th St; (S) \$100,000; L. Lutro, pres.; R. W. Strassberger, treas; Braids; steam; sell direct; N. Y. office, 127 Spring St.
- THOMAS & BROWN; 104, 106 E. 129th St.; (S) John R. Brown, supt.; Worsted, Silk and Mercerized Vestings; 40 looms; steam; sell direct; Myron E. Thomas, buyer. (Buy Egyptian yarns.)
- THURKAUF, VIRGIL; 433-35 W. 53rd St; (D) Dyeing of Skein Silk, Trams, Organzine, Etc; steam.
- TIEDEMANN, THEODORE, & SON; (D & F) 35-37 Wooster St; Spongers and Refinishers of Woolens; steam.
- TOFF, PROSNITZ & Co; 580 Broadway; (S) Dress, Cloak and Millinery Trimmings; steam; sell direct.
- TRAYERS BROS. Co; Liberty & Harmony (J) Mills; 107 Duane St; \$200,000; F. C. Travers, pres. V. Paul Travers, treas. and supt; Rope, Hammocks, Twines, Packing, Sash Cords; 100 looms; steam; dye; V. Paul Travers, buyer.
- UNGAR, M. & Co; 31 Bond St; Millinery (S) Trimmings, Drappings, Settings, Chemilles, etc; sell direct.
- UNION UPHOLSTERY TRIMMING CO; Henry (S) Meyers & Co; 603-607 W. 36th St.; A. Lederer, supt; Upholstery Trimmings; 50 looms; steam; A. Lederer, buyer.
- UNITED STATES FINISHING CO; (D & H) Pr s; 3,000,000; 320 Broadway; Joseph H. Wright, pres.; J. Hunt Smith, treas.; J. Millar Wilson, sec; Finishers of Cotton Piece Goods; 38 printing machines; 80 tons per day bleaching capacity; 12,000 pieces per day, dyeing. Works at Norwich, Conn., Sterling, Ct., Passaic, N. J. and Pawtucket, R. I.
- VERSEN, ALBERT F; 232 East 43rd St; (D) Silk Dyer.

- WASHINGTON EXAMINING, SPONGING AND (F) REFINISHING WORKS; Kinkel, Ellsah & Katz, props; cor. Prince St and West Broadway.
- WATERMAN, FELIX; 152 Wooster St; (S) Upholstery Trimmings.
- WEHRLIN, JOHN; 523 W. 45th St; Silk (S) Winding.
- WEIGLE & FINKE; Metropolitan Dye (D) Works; 140 E. 49th St.; steam; dye.
- WEISS, J.; Central Knitting Mills; 115 (K) First St; Wool and Worsted Sweaters, Bicycle and Golf Hose and Stockings; 17 knitting and 4 sewing machines; 1 winder and 1 spooler; sell direct.
- WERTHEIMER & HOLLANDER; Defiance (K) Knitting Mills; 139-161 Greene St; Sweaters, Golf Hose, Cardigan Jackets; 48 knitting machines; sell direct.
- WESSEL DYEING & PROOFING CO.; (D & F) 179-181-183 Wooster St.; Woolen and Worsted Dress Goods Dyeing and Finishing.
- WEST SIDE KNITTING MILLS CO; 611 W. (K) 36th St; \$25,000; W. F. Ritter, pres. and treas.; Jersey Ribbed Vests; 48 knitting machines; 40 sewing machines; steam; Critten, Clift & Co, s. agts.
- WICKE, WM. CO; (office 33rd St. and 1st (C) Ave.); \$800,000; Wm. Wicke, pres.; H. A. Fischer, Treas.; Narrow Silk Ribbons, Bindings and Gallons; 800 looms; steam; dye; Dresser and Olmstead and Walter Emmerich, N. Y. s. agts. (Mill at Richmond Hill).
- WIENBURG, C. & CO; 31-33 W. 23rd St; (S) Upholstery and Drapery Trimmings.
- WIENER, MARTHA & CO; 54 & 56 East 11th (S) St; Embroidery; 4 machines.
- WILLIAMS, PHILIP H., SON & CO; 35 & 37 (S) E. 20th St; W. M. Williams, supt; Upholstery Trimmings; sell direct.
- WILLIAMS SILK MFG. CO; 318-326 East (S) 23rd St; C. G. Williams, pres; L. P. Williams, treas; E. Emil Holzhalb, supt; Serges, Linings, etc.; 300 looms.
- WOLF & NEWMAN; 457-461 West Broadway; (S) Dress and Cloak Trimmings.
- WOODHOUSE, BOPP & CO. (formerly (S) Guyon, Woodhouse & Co.); 251-253 W. 67th St.; Max Doerken, supt. and buyer; all kinds of Dress Silks; 190 looms; steam; Boessneck, Broesel & Co, 466-468 Broome St, N. Y. s. agts.
- ZANDERER, J. CH; 165 Spring St; Dress (S) and Cloak Trimmings, Chemise Cords, Silk and Cotton Tape; 20 looms; electricity; sell direct.
- New York Mills.** G-14. N. Y. C. & H. R. RR, Mohawk Div. Electrics from Utica.
- NEW YORK MILLS, THE; \$1,400,000; (C, B, I, D) W. S. Walcott, pres; Samuel R. Campbell, treas.; Shirts, Sheets, Colored Goods, Corsetry and Velveteens; Fine, Hosiery and Mercerized Yarns; Dyeing and Bleaching; 75,000 spindles; 1800 looms; steam and water; A. D. Juilliard & Co, N. Y. s. agts. (Branch mill at Aragon, Ga.)
- WALCOTT & CAMPBELL SPINNING CO; (C) Troilus Mill (organized 1896); \$100,000; S. R. Campbell, pres; W. S. Walcott, treas; F. C. Walcott, agt; J. P. Campbell, mgr; Hosiery Yarns; 10,000 spindles; steam; dye.
- Niagara Falls.** G-4 G. T. RR, E. RR, W. C. RR, N. Y. C. & H. R. RR, N. E. & L. RR, R. W. & O. RR.
- CATARACT HAIR CLOTH CO; J. A. Mc. (C) Sloy, pres; H. E. Mesloy, sec. and treas; Haircloth Crinoline, Seating and Tailors' Padding; electric; dye; 160 looms; sell direct.
- FRENCH HICKMAN FLAX CO; office in (F) Boston; 161 Franklin St; Flax Fibre made from Flax Straw; water.
- NIAGARA FALLS HAIR CLOTH WORKS; (C) Jas. B. Rock, prop; Hair Cloth; 25 looms; steam and electricity; dye; sell direct.
- No. Hoosick.** H-19 Fitchburg RR.
- GLASGOW KNITTING MILLS CO. *Out of business; mill burned.*
- Norfolk.** A-14 (Near Raymondville) On Og & L. C. R. R.
- NORFOLK WOOLEX MILLS; W. S. Bennet (W) and Daniel Crowley, props.; Cassimeres; 1 set; 2 looms; water; dye.
- Northville.** F-17. F. J. & G. RR.
- NORTHVILLE KNITTING MILL; Ladies' (K) and Men's Ribbed Underwear and Jersey Gloves; 16 knitting machines; 32 sewing machines; steam; sell direct. *Not running.*
- Norwich.** J-13. N. Y. O. & W. RR, Northern Div; D. L. & W. RR, Utica Div.
- CHENANGO DYEING CO. *Reported out of business.*
- NORWICH SILK MFG. CO; John Erskine (S) & Co.; Ribbons; 6500 spindles; 100 looms; steam; dye; Schefer, Schramm & Vogel, s. agts.
- Nyack.** O-18. N. Y. L. E. & W. R. R.
- NYACK KNITTING CO; \$10,000; A. L. (K) Thompson, pres; F. H. Brayton, treas. and buyer; John Bellis, supt; Ladies' Ribbed Underwear; 15 knitting machines; electric power; sell direct. (Buy carded Peeler 12 to 9.)
- PEERLESS FINISHING CO; \$50,000; G. (D & F) W. Watson, pres.; J. B. Tate, treas.; James Watson, agt.; Dyeing and Finishing of Silk and Silk and Cotton Goods; steam and electricity.
- Ogdensburg.** A-14. C. V. RR, Ogdensburg & Lake Champlain Div; R. W. & O. RR, Ogdensburg Br.
- McGUIRE, F. S. Co. (LTD); Ogdensburg (W) Woolen Mill; Yarns and Tweeds; 1 set; 264 spindles; 3 looms; water; dye; sell direct. (Also make pantaloons at mill.)
- OSWEGATCHIE MFG. CO; Silks. *Proposed.* (S)
- Oneida.** G-13. N. Y. C. & H. R. RR, Mohawk Div; N. Y. O. & W. RR, Northern Div.
- JOHNSON, J. L.; Hosiery. (K)
- MORGAN, THOS; John F. Morgan, supt; (K) Seamless Hosiery; 8 knitting machines; steam; dye; sell direct.
- ONEIDA HOSIERY CO; \$20,000; Willard J. (K) Frisbie, pres; Geo. A. Frisbie, treas; C. H. Oakes, sec; Jesse F. Burton, agt; Seamless Hosiery; 80 knitting machines; steam; dye; sell direct.
- Oneonta.** J-15. D. & H. RR, Susquehanna Div.
- GLOVERSVILLE KNITTING CO; Branch (K) mill for Finishing Gloves. (See Gloversville.
- PARAGON SILK CO; \$100,000; E. H. Rosenheim, pres.; O. G. Rosenheim, treas.; J. G. Dreyfus, supt.; Broad Silks; 82 looms; steam; J. A. Blum, 37 Greene St., N. Y., s. agt. (See also Paterson, N. J.)
- Oriskany.** G-14. N. Y. C. & H. R. RR, Mohawk Div.
- WATERBURY, H. SONS & CO; \$150,000; (W) J. E. Waterbury, pres. and buyer; H. T. Waterbury, treas; Paper Maker's Felts and Blankets; 9 sets; 40 broad looms; steam and water; dye; sell direct.
- Oriskany Falls.** G-14. N. Y. O. & W. RR, Utica Div.
- CUNNINGHAM, JAS. & SON; Scotch Caps (K) and Woolen Sweaters; 2 sets 576 spindles; 16 knitting and 20 sewing machines; steam; dye; Mohawk Valley Cap Factory, Utica, N. Y. s. agts., for caps; sell sweaters, direct.

- HATHEWAY & REYNOLDS;** Caps, Sweat-(**K**) ers and Knit Goods; 5 sets; 50 knitting machines; steam and water; dye; sell direct; H. H. Hatheway, buyer.
- UTICA KNITTING CO;** No. 3 mill; Ribbed (**K**) Underwear; water; sell direct.. (See Utica, N. Y.)
- Oswego.** F. 11. D. L. & W. RR, Oswego & Syracuse Div.; N. Y. O. & W. RR, Northern Div.; R. W. & O. RR, Syracuse Div.
- CONDE FRED'K;** Knit Underwear; 150 (**K**) knitting machines; steam and water; dye; Critten, Chft & Co.; N. Y., s. agts.
- CONDE CO. THE SWITS;** Chas. B. Leonard, (**K**) treas.; Fancy Overshirts and Underwear; about 100 knitting machines; salesroom, 108 and 110 Franklin St., N. Y.
- MOHAWK MFG. CO;** \$25,000; H. D. Diment, (**W**) pres and agt.; E. B. Mott, treas.; Wool and Wool and Cotton Mixed Yarn and Shoddy; 19 sets; 6 shoddy cards; 8000 spindles; 5 pickers; 2 humpers; water; dye; sell direct.
- OSWEGO KNIT NG CO;** \$10,000; Fred C. (**K**) Osterhout, pres; Wm. L. Moore, treas.; John Palmer, supt.; Summer Weight Underwear; 10 knitting machines; steam.
- STANDARD YARN MILL;** (Swits Conde Co.) (**C**) J. G. Merriman, Jr., gen'l mgr. and buyer; Cotton Hosiery and Underwear Yarns; 10,000 spindles; steam and water.
- Otto.** J. 5. N. Y. L. E. & W. RR; Western Div.
- PIERCE, CHARLES B;** Otto Woolen Mills; (**W**) Wool Dress Goods, Cassimeres; 2 sets; 20 looms; water and steam; sell direct.
- Patchouge.** P. 20. L. 1 RR, Montauk Div.
- PATCHOUGE MFG. CO;** \$50,000; L. D. Ein. (**C**) stein, pres; Martin Helmsendorfer, treas.; F. Guttridge, mgr.; Lace Curtains; 24 looms; steam and water; dye; Henson & Small, 458 Broadway, N. Y., s. agts.
- Perry.** H. 7. L. S. RR.
- PERRY KNITTING CO. THE;** \$100,000; (**C&K**) M. H. Olin, pres; W. H. Tuttle, treas.; G. M. Traber, mgr.; J. E. Traber, supt.; Boys' and Children's Fleece and Ribbed Underwear; 6 sets; 5,500 spindles; 76 knitting machines; 28 sewing machines; steam and water; dye; sell direct.
- Philmont.** K. 19. N. Y. C. & H. R. RR, Harlem Div.
- AKEN KNITTING CO. THE;** \$225,000; 256 (**K**) Church St., N. Y.; W. S. C. Wiley, pres; Millard G. Thomas, treas.; Merino Underwear and Overshirts and Fleece Lined; 24 sets; 6332 spindles; 104 knitting machines; steam and water; dye; sell direct and Porter Bros. & Co., a. agts.; Willard G. Thomas, buyer.
- HAYES, JOHN, & Co;** Midland Hosiery (**K**) Mill; John Hayes, supt.; Cotton Fleece Lined and Cotton and Wool Mixed Underwear; 3 sets; 900 spindles; 21 knitting machines; 25 sewing machines; steam and water; sell direct.
- HIGH ROCK KNITTING CO;** \$90,000; P. M. (**K**) Harder, pres; F. B. Harder, vice-pres.; W. G. Harder, supt.; F. B. and W. G. Harder, buyers; Men's Cotton and Wool Fleece and Wool Mixed Underwear; 10 sets; 3120 spindles; 67 knitting machines; steam and water; sell direct, 365 N. Y. Life Bldg., N. Y. (Buy colored and white 22s on cones, cotton yarns only)
- Phoenix.** F. 12. N. Y. C. & H. R. RR.
- DUFFY SILK CO. THE;** Throwing, alone, (**S**) (Also at Buffalo and Fort Plain.)
- Phoenix Mills.** J. 15. C. & C. V. RR.
- INDEX KNITTING MILLS;** Theo. Freyling, (**K**) huysen (New York); John P. Doane, supt.; Fleece-lined and Ribbed Underwear; No. 1 Mill; 74 knitting machines; steam and dye; water; No. 2 Mill; 2 sets; 576 spindles; water and steam; Wm. P. Iselin & Co., and Converse, Stanton & Co., N. Y., s. agts; John P. Doane, buyer.
- Pleasant Valley.** M. 18. P. & E. RR; P. H. & H. E. RR.
- GARNER & CO;** Pleasant Valley Cotton (**C**) Mill; Wm. E. Thorn, pres. and treas.; John Knott, supt.; Print Cloths; 56X56, 27 in.; 3624 mule spindles; 88 looms; steam and water; Garner & Co., 10 Worth St., N. Y., s. agts. and buyers.
- Port Jervis.** N. 16. N. Y. L. E. & W. RR; P. J. M. & N. Y. RR.
- CHANT, T. N.;** Silk Gloves, Etc; gas. (**S**) (Make on commission.)
- KATTERMAN & MITCHELL** (Paterson); H. (**S**) A. Wylie, supt.; Dress and Tie Silks, Linings, Etc; 75 looms; water; sell direct.
- Poughkeepsie.** M. 18. N. Y. C. & H. R. RR, Hudson River Div.; P. & E. RR; P. R. & N. E. RR.
- FALKHILL KNITTING CO;** \$20,000; C. W. (**K**) H. Arnold, pres. and treas.; Geo. R. Arnold, supt.; Cotton Underwear; 50 knitting machines; 50 sewing machines; steam; dye; Bolger & Brewster, N. Y., s. agts. (Buy yarns, 16 to 24.)
- HOAG, C. F.;** Lindenwald Mills; Asa (**K**) Hoag, supt.; Sweaters, Leggings, Toques, Mittens and Fancy Goods; 140 knitting machines; electric and steam; sell direct; Asa Hoag, buyer. (Buy yarn 2/23, 4/10, 3/14.)
- TITUS FLANNEL Co.;** Rochdale Mills; (**W**) (Mill at Rochdale.) H. P. Titus, supt.; Fine White Flannels; 3 sets; 2,836 spindles; 22 broad looms; steam and water; sell direct.
- Pulaski.** E. 12. R. W. & O. RR., Syracuse Div.
- MAHOFFY BROS;** Pulaski Woolen Mills; (**W**) D. C. Mahoffy, supt.; Cassimeres, Flannels and Yarns; 1 set; 2 custom roll cards; 3 looms; water; dye; sell direct; D. C. Mahoffy, buyer.
- Releigh.** G. 19. D. & H. RR, Washington & Ruttand Br.
- MARBLE KNITTING MILLS, THE;** Geo. E. (**K**) Brockway, prop; Camel's Hair, Natural Wool and Scarlet Underwear; 3 sets; 15 knitting machines; water; Isaac P. Graff & Co., N. Y., s. agts; Geo. E. Brockway, buyer. *Mill not in operation*
- Richfield Springs.** H. 15. D. L. & W. RR, Richfield Springs Br.
- RICHFIELD SPRINGS SCOTCH CAP CO;** Guy (**K**) Kinne, pres.; A. J. Wainman, treas. and supt.; Scotch Caps, Toques and Tam O'Shanter's; 2 sets; 22 knitting machines; steam; dye; sell direct; A. J. Wainman, buyer.
- WAIONTHA KNITTING CO, LTD;** \$10,000; (**K**) Allen Bloomfield, pres; Madison Vedder, treas.; J. B. Bringloe, agt. and supt.; Ladies' and Misses' Cotton Ribbed Goods; steam; sell direct; Room 942, N. Y. Life Bldg., N. Y.; J. B. Bringloe, buyer. (Buy 9, 10, 11 combed and carded Peckers, Egyptians, Selters and Jacques.)
- Rifton Glen.** L. 17. W. S. RR, Hudson River Div.
- DIMICK Co;** J. W. See Esopus.
- Rochester.** G. 8. N. Y. C. & H. R. RR; R. & L. O. RR; B. R. & P. RR, Rochester Div.; R. W. & O. RR, Rochester Br.; W. N. Y. & P. RR, Rochester Div.; L. V. RR, Rochester Br.; W. S. RR, Buffalo Div.; N. Y. L. E. & W. RR, Rochester Div.
- ACME HOSEERY Co.;** \$6,000; (formerly L. (**W**) J. Gruber's mill); J. E. Pulver, pres.; H. J. Marsh, treas.; L. J. Gruber, vice-pres. and mgr.; Half Hose; (use 1/34s to 1/28 combed Egyptian yarn); 7 knitting machines; steam; sell direct; L. J. Gruber, buyer.

- ALLEN WOOLEN MILLS:** \$100,000; Flan- (W) nels, Dress Goods, Cloakings, Etc.; 6 sets; 36 looms; steam; dye; Oelhermann, Dommierich & Co, N. Y., s. agts.
- FLOWER CITY DYE WORKS:** HARTY (D B) Broom, prop; 170-176 Orchard St.; Dyeing and Bleaching Worsted, Cotton and Silk Yarns, Genapps and Mohair a Specialty; steam; Harry Broom, buyer.
- GARNER & CO.:** Rochester Cotton Mills. *Sold to Rochester Gas & Elec. Ric Co.*
- GENESEE TRIMMING WORKS.** *See Union Textile Mfg. Co.*
- HUTCHINSON, W. H., & Co.** Mill burned. (*See Union Textile Mfg. Co.*)
- IDEAL KNITTING WORKS:** F. F. Robinson, (K) prop.; 200 Jay St.; Cotton Half Hose in all Shades; 6 knitters; 2 ribbers; 1 looper; electricity; sell direct; F. F. Robinson, buyer. (Buy cotton on cones, 15, 16, 50 and 60.)
- LEARY DYEING AND CLEANING WORKS:** (D) Edward B. Leary, prop; Dyer and Cleaners Yarns, Piece Goods, Carpets and Garment Work; steam.
- LOWENTHAL, MAX, & BRO:** Rochester (K) Knitting Works; Infants' Vests and Bands, Children's Underwear, Golf Gloves, Mittens, Leggings, Equestrian Tights; 47 crocheting and sewing machines; 132 knitting machines; electricity; sell direct; Louis Lowenthal, buyer. (Buy worsted singles and 2 ply, 20 to 60; cotton combed and carded, 1/12 to 1/30; also some silk.)
- ROCHESTER BATTING MILLS:** \$15,000; (C) Dr. M. C. Rutherford, pres.; Edward G. Hartel, sec.; John Kubel, treas; Geo. F. Hoffman, mgr; Cotton Batting, Surgical Cotton and Fire Proofing of Cotton Batting; water; sell direct; Geo. F. Hoffman, buyer.
- ROCHESTER TEXTILE WORKS:** 233 Mill (C) St.; \$52,000; L. P. Warner, pres.; F. L. Williams, treas; Couch Lace, Braids, Brush Dress Bindings, Shoe Laces, Etc.; 10 looms; 20 braiders; steam; sell direct; pres. and treas., buyers. (Buy cotton 6/3, 8/3, 20/2, 30/2, 40/2 and 2/26 worsted yarn.)
- SCHLEGEL MFG. CO, THE:** 29 Canal St. (S) \$75,000; C. P. Schlegel, pres; G. C. Schlegel, treas.; Dress, Carriage, Hears and Casket Trimmings; 60 looms; steam; sell direct; G. C. Schlegel, buyer. (Buy cotton yarn 10/2 to 50/2 and worsted 2/36.)
- UNION TEXTILE MFG. CO. (successors to S) W. H. Hutchinson & Co., The Geneesee Trimming Works and The Brighton Mfg. Co.);** A. E. Vogt, mgr.; Carriage Trimmings; sell direct.
- VOGT MFG. & COACH LACE CO:** \$135,000. (S) A. Vogt, pres. and treas; H. L. Brewster, vice-pres; E. G. Pfohl, sec; Casket and Hears Trimmings and Fringes; 101 looms; 81 braiders; electric; sell direct.
- WARNER & WILBER.** *Out of business.*
- Rockwell's Mills.** J-15. N. Y. O. & W. RR, New Berlin Br.
- ROCKWELL, C. W., & Co;** Allen Rock. (W) well, supt.; All Wool Cassimeres; 3 sets; 15 looms; steam and water; dye; sell direct; Allen Rockwell, buyer.
- Rome.** F-14. N. Y. C. & H. R. RR, Mohawk Div.; N. Y. O. & W. RR, Rome Br; R. W. & O. RRs.
- COLUMBIA KNITTING MILLS:** W. H. Doyle, (K) supt.; Men's Balbriggan Goods; 60 knitting machines; steam; dye; sell direct and James Talcott, s. agt; W. H. Doyle, buyer. (Buy yarn.)
- FORT STANWIX KNITTING CO:** \$30,000; (K) W. J. Carroll, pres. and mgr.; W. J. Doyle, treas.; Men's Balbriggan Underwear; 26 knitting machines; steam; sell direct and Bacon & Co., N. Y., s. agts.; W. J. Carroll, buyer.
- ROME TEXTILE CO:** 313 N. Joy St.; (K) \$15,000; Arthur J. Wylic, pres; E. A. Vary, sec. and treas; Ladies' and Children's Rib Underwear; 33 knitting and 34 sewing machines; steam; Bacon & Co, N. Y., s. agts.
- WILLIAMS BROS. MFG. CO.:** Rome Steam (K) Knitting Mills; \$100,000; J. S. Haselton, pres.; J. Lowell Williams, Jr., treas.; Fine Balbriggan, Fancy and Plain Cotton and Silk Underwear; 120 knitting machines; steam; dye; Wm. Iselin & Co., I Greene St., N. Y., s. agts; J. L. Williams, Jr., buyer.
- Rondout.** L-18. Ulster & Delaware RR, West Shore RR; Central Hudson S. B. Co.
- CORNELL KNITTING CO;** John Heany, (K) prop; D. L. McCreery, supt.; Children's and Infants' Ribbed Underwear; 27 knitting machines; 50 sewing machines; steam; dye; W. H. Burgess & Co, 42 Leonard St, N. Y., s. agts.
- Rossmann.** K-18. (Columbia Co.) K. & H. RR.
- ROSSMAN KNITTING CO:** \$75,000; Leon. (K) and J. Rossmann, pres; Edgar J. Rossmann, treas.; Benj. F. Haigh, supt.; Men's Fleece Lined Underwear; 5 sets; 1500 cotton spindles; 22 knitting machines; water; sell direct; Edgar J. Rossmann, buyer. (Buy 22s white and colored.)
- Sand Lake.** J-19. Electric Cars from Troy, See also West Sand Lake.
- BEVERWYCK MILLS.** See Faith Knitting Co, Averill Park.
- Sandusky.** J-6. W. N. Y. & P. RR, Buffalo Div; B. A. & A. RR; B. R. & P. RR, Rochester Div.
- HAYDEN, THEO;** Flannels, Shirts and (W) Yarns; 1 set; 4 looms; water; dye; sell direct.
- Sauquoit.** G-14. D. L. & W. RR, Utica Div.
- LEWIS KNITTING CO, THE;** Children's (K) Cotton Underwear; 30 cylinders and 80 knitting machines; steam and water; sell direct. (Buy 8, 9, 18, 20 and 22 cotton yarns, cops or cones, Prelers or mixos.) (Purchase plant of Sauquoit Silk Mfg. Co.)
- Schaghticoke.** H-19. F. RR, Western Div.
- CABLE FLAX MILLS** \$100,000; 52 Leon. (F1 & J) and St., N. Y.; Luman H. Gibbs, pres. and treas; Sanford H. Moses, sec; A. B. Ralston; supt; Flax, Hemp and Jute Twines, Yarns and Threads; 3000 spindles; steam and water; dye; sell direct.
- SCHAGHTICOKE MILLS CO:** \$50,000; (of. (W) rice 54 Worth St, N. Y.); S. W. Ingalls, pres; E. E. Leonard, treas; F. C. Werner, supt; Worsted, Cassimeres, Cheviots, Overcoatings; 15 sets; 87 looms; water; dye; sell direct; E. E. Leonard, buyer.
- Schenectady.** H-18. N. Y. C. & H. R. RR, Mohawk Div; D. & H. RR, Schenectady Br.
- ALPHA KNITTING CO;** \$50,000; D. S. (K) Mann, pres. and treas; Knit Underwear; 12 sets; 3126 spindles; 42 knitting machines; steam; dye; Critten, Clift & Co, N. Y., s. agts; D. S. Mann, buyer. (Buy yarn 14 to 20.)
- HENKELS, ALB. & E;** (Langerfeld, Ger. (C) many); (P. O. Box, 293); A. Attenborough, mgr.; Laces; 4000 spindles; 150 lace machines; electricity; sell direct. (Buy cotton yarn 26 and 14/2 and linen 37 1/2 and 67/2.)
- HORSTMAN CHAS. & Co.** *Out of business.*
- Seneca Falls.** G-10. N. Y. C. & H. R. RR, Auburn Br.
- SENECA WOOLEN MILLS;** John P. Cham. (W) berlin; Thomas Hinchliffe, supt.; Overcoatings and Cloakings; 7 sets; 33 looms; water; dye; sell direct; 640 Broadway, N. Y.

**Sherburne.** H-13. D. L. & W. RR, Utica Div.

CANASAWACTA KNITTING CO; \$25,000; (K) William H. Wild, pres. and supt; Francis J. Frey, treas; Men's Ribbed Underwear; 37 knitting machines; steam; dye; sell direct; Wm. H. Wild, buyer. (Buy yarns from 8s to 20s.)

UTICA KNITTING CO; No. 5 mill; Spin- (C) ning Cotton Yarns. (See Utica.)

**Sherrill.** See Kenwood.

**Sidney.** K-14. N. Y. O. & W. RR; D. & H. RR, Susquehanna Div.

CLARK TEXTILE CO; \$200,000; J. H. Clark, (S) pres; Ladies' Woven Tip Silk Gloves; 30 looms; steam; dye; sell direct; J. H. Clark, buyer.

MONARCH KNITTING CO.; \$25,000; G. B. (K) Cramer, pres.; H. Dutton, sec. and treas.; Ladies' Silk Vests and Knit Goods; 12 knitting machines; electric motor; sell direct.

**Sing Sing.** O-18. N. Y. C. & H. R. RR.

STATE PENITENTIARY; Men's Hose and (K) shirts; 80 knitting machines. (Knitting dept., Clinton Prison, removed here.)

**Skaneateles Falls.** G-11. Skaneateles RR.

AYRESHIRE WOOLEN MILLS; Gavin Mor. (W) ton & Co; Henry Huntton, supt; Cassimeres; 5 sets; 25 looms; steam and water; dye; Bacon & Co, N. Y., s. agts; F. S. Boothroyd, buyer.

GLENSIDE WOOLEN MILLS; \$250,000; Geo. (W) Barrow, pres; Theo. W. Specht, treas; Jas. Mitchell, supt; Union Broadcloths; 6 sets; 70 looms; steam and water; dye; Arnstaedt & Co, 68 Greene St, N. Y., s. agts; Theo. W. Specht, buyer.

GLENSIDE WOOLEN MILLS; Overbrook (W) Mills; Shoddy; 3 machines; steam and water.

**Slattsburg.** N-17. N. Y. L. E. & W. RR, Eastern Div.

MCCULLOUGH, ROBT; Spun Silk; see Pat- (S) erson, N. J.

**South Otsego.** J-13. (RR. Station De Ruyter); Lehigh Val RR, Elmira Br.

GLADDING B. F. & Co; Ralph R. Brown, (C) supt. and buyer; All Kinds Braided and Twisted Fishing Lines; 320 braiders; 42 laying machines; steam and water; sell direct.

**So. Westerlo.** J-18. W. S. RR, Albany Div; (RR. station, Coxsackie).

CALDER, W. D; Flannels, Satinets, (W) Cassimeres, Yarn, Hosiery; 1 set; 3 looms; 1 knitting machine; water; dye; sell direct; buys 12 and 16.

**Spring Valley.** O-17. N. J. & N. Y. RR; N. Y. L. E. & W. RR, Piermont Br; N. RR, of N. J.

DUNLOP, BROS. & Co; 487 Broadway, N. Y.; (S) Tie and Dress Silks; 10,000 spindles; 100 looms; steam; Oelbermann, Dommerich & Co, N. Y., s. agts.

DUNLOP'S, JOHN, SOXS; J. D. Dunlop, supt; (S) Orgazine, Tram, etc; 16,000 spindles; 100 looms; steam

**Stapleton.** P-17. S. I. R. Transit.

RICHMOND MFG. CO.; H. A. Sanders, (W) prop; mill at Stapleton, Staten Island; Cotton and Woolen Goods; 2 sets; steam; dye; N. Y. office, 47 Leonard St.

**Stillwater.** G-18. F. RR, Saratoga Br.

NEWLAND, DENISON & Co; Hudson River (K) Hosiery Mill; John O. Pack, supt. and buyer; Knit Underwear, Fleece Lined; 4 sets; 31 knitting machines; 50 sewing machines; water; A. D. Juilliard & Co, N. Y., s. agts. Buy cotton yarn.

NEWLAND, R. & H.; Saratoga Hosiery (K) Mills; F. P. Tucker, supt; Men's Merino and Fleece Lined Underwear; 6 sets; 1400

spindles; 25 knitting machines; 35 sewing machines; steam and water; sell direct; 377 Broadway, N. Y.; David Newland, buyer.

**Stittville.** F-14. R. W. & O. RR, Utica & Ogdensburg Line.

HACKETT & ARWOOD; Empire Knitting (K) Mills; Knit Goods; 5 sets; 20 knitting machines and water; Porter Bros. & Co, N. Y., s. agts.

**St. Johnsville.** G-16. N. Y. C. & H. R. RR, Mohawk Div; W. R. RR, Buffalo Div.

LION MFG. CO; \$50,000; T. Foster, pres; (K) C. E. Taylor, treas; supt and buyer; J. R. Fleeman, agt; Knit Underwear; 75 knitting machines; steam; sell direct;

ROYAL MILLS; J. H. Reaney, pres; Jos. (K) L. Moore, treas; Ladies' Ribbed Cotton Underwear; 95 knitting machines; steam; sell direct and Condit & Arnold, s. agts; J. H. Reaney, buyer.

UNION KNITTING MILL; Wesley Alter, (K) prop; Men's Cotton Ribbed, Fancies and Colored Underwear; 70 cylinders; 50 sewing machines; steam, water and electric; sell direct.

**Stottville.** K-18. K. & H. RR.

STOTT WOOLEN CO.; \$100,000; Charles H. (W) Stott, pres.; Frank L. Stott, treas; Flannels and Dress Goods; 44 sets; 320 looms; steam and water; dye; A. D. Juilliard & Co, s. agts.

**Stuyvesant Falls.** K-18. K. & H. RR.

VAN ALLEN COTTON MILLS; Chas. Fris. (C) bee, mgr; Print Cloths; 16,000 spindles; 400 looms; water; sell direct.

**Syracuse.** G-12. N. Y. C. & H. R. RR; W. S. RR; D. L. & W. RR; R. W. & O. RR.

CLINTON KNITTING CO; 216 Wyoming St; (K) Ladies' and Children's Jersey Ribbed Underwear; 100 knitting machines; steam; sell direct. (Buy yarn, 9 to 12s.)

OAK KNITTING CO; Charles E. Crouse (K) and Adolph G. Velasco; Ladies' and Children's Jersey Ribbed Underwear; 75 knitting machines; steam; sell direct; A. G. Velasco, buyer. (Capacity 600 doz. daily.)

SAGER, A; Mittens and Leggings; 30 ma- (K) chines; hand power.

SAGER BROS; 43-47 So. Clinton St; (K) silk, Worsted and Mohair Knit Goods, 35 knitting machines; sell direct; A. Park Sager, buyer.

SYRACUSE SILK CO; \$100,000; Louis (S) Will, pres; Edwin S. Brown, treas. *Burned; some talk of rebuilding*

WEST BROS; Onandaga Knitting Mills; (K) 101 Bridge St; Ribbed Underwear; 41 knitting machines; 64 sewing machines; Critten, Clift & Co, N. Y., s. agts.

**Tarrytown.** O-18. N. Y. C. & H. R. RR, Hudson River Div; N. Y. & P. RRs.

HUSTED, A. P.; Silk, Chemille, Etc.; (S) steam; sell direct.

**Tottenville.** P-17. Staten Island Rapid Transit RR.

BARNARD, BELLE F.; Undertakers Trim- (S) mings, Gimps and Fringes; 30 looms; steam; Theo. Liedmann & Son, s. agts. *Mill at Richmond Valley, S. I.*

**Troy.** H-18. N. Y. C. & H. R. RR, Hudson River Div; D. & H. RR, Saratoga Div; F. Troy & Boston Line, RRs.

ADAMS & RUDD. *Out of business.*

COMMERCIAL KNITTING MILLS CO; 43 (K) Leonard St, N. Y.; \$175,000; F. M. Aufesser, pres; J. M. Burnet, treas; Andrew Akub, supt; Knit Underwear; 11 sets; 120 knitting machines; 250 sewing machines. (Buy cotton yarns, 7s to 30s.) (See Cohoes.)

DRAPER, W. H., & SON; Fish and Chalk (C) Lines, Cotton Twine; Cotton Braided

- Cordage and Wire Picture Cord; 1400 spindles; 180 braiders; steam; sell direct and Catlin & Co., N. Y. and Boston, s. agts.
- ELLIS, EDWIN J.**; Novelty Cordage Wks: (J) 876 5th Ave; Hair Cordage and Press Mats, Etc; water.
- ROB ROY HOSIERY CO.**; \$50,000; T. F. Bar. (K) num, treas.; Robert W. Lutton, supt.; Men's, Ladies' and Children's Woolen Underwear; 5 sets; 32 knitting machines; steam; dye; C. A. Brown & Co., Troy and N. Y., s. agts.
- TROY KNITTING CO.**; \$100,000; James (K) O'Neil, pres; Peter McCarthy, treas; Wm. D. Mahony, asst. treas. and mgr; John Nolan, supt; Fleece and Flat, Cotton, Merino and Wool Goods; 9 sets; 2,240 cotton spindles; 44 knitting machines; steam and water; dye; E. C. Goodwin, N. Y. Life Bldg., N. Y., s. agt.; John Nolan, buyer.
- UNITED WASTE MFG. CO.**; 145 River (C & W) St.; Chas. H. Kavanagh, pres; W. H. Rowe, Jr, vice-pres; James H. Shine, sec; Jos. J. Murphy, treas; John J. Ryan, gen'l mgr; Cotton, Wool and Merino Shoddies; 8 garnets; 5 pickers; 2 dusters; water; also Wholesale Dealers in Wastes. (Mill at Cohoes.)
- WAYSIDE KNITTING CO.**; \$60,000; W. H. (K) Rowe, Jr, pres; F. J. Wood Rowe, treas; W. E. Cunningham, sec.; L. E. Shaver, supt.; Cotton and Woolen Underwear; 17 sets; 75 knitting machines; steam; W. H. Rowe & Son, 97 Franklin St., N. Y., s. agts.; L. E. Shaver, buyer.
- WRIGHTS HEALTH UNDERWEAR CO.**; (K) Ethna Mill; \$120,000; S. Wright, pres; S. Wright, Jr., sec. and treas.; Cotton, Woolen and Mixed Knit Underwear; 8 sets; 40 knitting machines; 100 sewing machines; steam; sell direct; 75 Franklin St., N. Y. (See Hoboken, N. J. and Pownal, Vt.)
- Unionport.** (Sub Station New York City.)
- UNIONPORT SILK MILL**; branch of Astoria (S) Silk Wks; Broad Silks and Satins; 150 looms; steam. (See Long Island City.)
- Utica.** G. H. N. Y. C. & H. R. RR, Mohawk Div; W. S. RR, Buffalo Div; D. L. & W. RR, Utica Div; N. Y. O. & W. RR, Utica Div; R. W. & O. RR, Utica & Ogdensburg Line.
- ALBION KNT GOODS CO.**; (J) and P. (K) Morgan, sole owners; Sweaters of Every Description; electricity; J. Morgan, buyer.
- ALLISON, G. F. & Co.**; Wiping Waste; (W) 2 waste machines; steam.
- ARGO KNITTING CO.**; 9-15 Charlotte St.; (K) Infants' Fine Hosiery; 18 knitting machines.
- ATHLETIC KNITTING CO.**; C. H. Yates & (K) Co, props; Sweaters and Golf Hose; 35 knitting machines; sell direct; C. H. Yates, buyer.
- AVALON KNITTING CO.**; 327-331 Bleeker (K) St.; \$50,000; A. J. Williams, pres.; H. F. Mansfield, vice-pres.; Beecher M. Crouse, sec. and treas.; Knit Underwear; 30 knitting machines.
- CAPRON KNITTING CO.**; \$50,000; C. A. (K) Byington, pres.; John A. Roberts, treas.; W. R. Schremp, sec., supt. and buyer; Cotton Fleece-lined Ribbed and Balbriggan Underwear; Men, Boys and Children; 146 knitting machines; steam and electricity; dye; sell direct.
- ELBOEFF KNITTING CO.**; Van R. Weaver, (K) pres. and treas.; Jno. Morgan, supt.; Sweaters, Golf Hose and Sporting Goods; 30 knitting machines; sell direct.
- FISHER MFG. CO.**; \$50,000; M. J. Fisher, (K) pres. and mgr.; B. L. Fitch, sec. and treas.; Knit Goods; 50 knitting machines; electricity.
- FORT SCHUYLER KNITTING CO.**; \$15,000; (K) Ezra R. Pugh, pres; Chas. P. Clarke, treas; Ladies' Swiss Ribbed Cotton, Merino, Wool and Silk Underwear; 22 knitting machines; electric power; Wm. Iselein & Co.; s. agts; Chas. P. Clarke, buyer.
- GLOBE WOOLEN CO.**; \$300,000; Walter D. (W) Middleton, pres. and agt.; E. T. Batford, sec. and treas.; Fancy Worsteds, Cassimeres, Piece Dyes, Kerseys, Meltons, Chevots and Coatings; 31 sets; 8 combs; 166 broad and 15 narrow looms; steam; dye; Stanley H. Ray, s. agt.; N. Y. office, 379 Broadway.
- HIGHLAND KNITTING MILL** (Utica Knit- (K) ting Mill, No. 2); Misses', Youths' and Men's Ribbed Underwear; 60 knitting machines; 100 sewing machines; sell direct; N. Y. office, N. Y. Life Bldg.
- KENDALL KNITTING CO.**; (organized 1895); (K) \$50,000; Willard J. Frisbie, pres; Geo. A. Frisbie, treas; Chas. A. Byington, sec. and supt; Women's and Children's Jersey Ribbed Underwear; 150 knitting machines; steam; sell direct and E. I. Goodrich, 919 N. Y. Life Bldg, N. Y., s. agt; Chas. A. Byington, buyer.
- LA TOSCA KNITTING CO.**; \$6,000; W. Fred (K) Allen, pres.; John E. McLaughlin, treas ; Geo. J. McLaughlin, supt.; Ladies' Goods; 25 knitting machines; steam; dye; sell direct and John D. Ashworth & Bro., N. Y.; John E. McLaughlin, buyer. (Is a department of Mohawk Valley Cap Factory.)
- LYNCH SCOTCH CAP CO.**; Scotch Caps; 15 (K) machines.
- MOHAWK VALLEY CAP FACTORY**; \$125,- (K) 000; W. Fred Allen, pres; J. E. McLaughlin, treas; Geo. G. McLaughlin, supt; Caps of all kinds; Ladies' Ribbed Underwear and Fancy Knit Goods; 4 sets; 100 knitting and 100 sewing machines; steam; dye; sell caps direct; Geo. E. Ashwell & Bro., N. Y., underwear; N. Y. office 42 Washington Place; J. E. McLaughlin, buyer.
- MOHAWK VALLEY COTTON MILLS.** See (C) *Utica Steam and Mohawk Valley Cotton Mills.*
- NORTROP, D. W. Co.**; Scotch Caps and (K) Mittens; 3 sets; 19 knitting machines; steam; dye; L. Topfitz, N. Y., s. agt.
- OLYMPIAN KNT GOODS CO.** *Removed to New Hartford, N. Y., which see.*
- ONEITA KNITTING MILLS**; \$300,000; John (K) B. Wild, pres; Nicholas E. Devereux, treas. sec. and agt; A. Frey, supt; Underwear, "Oneita" Union Suits; 7 sets; 2,566 woolen spindles; 170 knitting machines; steam; dye; Bolger & Brewster, Wm. Iselein & Co., N. Y., s. agts; A. Frey, buyer. (New yarn mill built; 15,000 cotton spindles; electricity.)
- REGAL TEXTILE CO.**; \$50,000; W. J. (K) Frisbie, pres; Geo. A. Frisbie, treas; Chas. A. Byington, sec. and mgr.; Fleece-lined Ribbed Underwear; 75 knitting machines; steam; sell direct; Chas. A. Byington, buyer. (Buy cotton yarns, 7 1/2 to 14s.)
- RICHIEU KNITTING CO.**; \$25,000; Chas. (K) A. Byington, pres.; George A. Frisbie, treas.; W. J. McQuade, supt.; Swiss Ribbed Underwear, Cotton, Lisle, Silk and Mercerized; 25 knitting machines; electricity; H. W. Byant, 919 Life Bldg., N. Y. s. agt.; Charles A. Byington, buyer.
- SEAL BACK UNDERWEAR CO.**; \$10,000; M. (K) J. Fisher, pres.; John A. Kernan, treas.; Ladies' Cotton Ribbed Underwear; 50 knitting machines.
- SKENANDOA COTTON CO.**; \$600,000; N. E. (C) Kernan, pres; Nicholas E. Devereux, sec. and treas; D. W. Gray, supt. and buyer; Hosiery Yarns in Cop, Skein and Cone; 59,424 mule and 4,576 ring spindles; steam; sell direct.
- ST. VINCENT INDUSTRIAL SCHOOL**; Bro. (K) Julian, pres. and buyer; Cotton and

- Woolen Seamless Half Hose; 65 knitting machines; steam; Rowe & Cronin, Troy, N. Y., s. agts.
- UTICA HOSIERY CO;** C. H. Yates & Co. (**K**) props; Infants' Cassimere Stockings; 50 knitting machines; sell direct; C. H. Yates, buyer.
- UTICA DYEING CO;** 3rd Ave. and (**D**) Broad St; \$10,000; H. L. Shuttleworth, pres. supt. and buyer; R. B. Billings, treas; Dyeing and Bleaching Yarn, Cloth, Raw Stock, etc; steam.
- UTICA KNITTING CO;** \$750,000; Mills No. 1, (**K**) 2 and 4; Q. McAdam, pres; J. W. Allis, vice-pres; Geo. E. Farrell, treas. and supt; All Kinds of Underwear; 14 sets; 44,000 mule spindles; 235 knitting machines; steam and water; sell direct; N. Y. office, Room 923, N. Y. Life Bldg; Quentin McAdam, buyer. (Also Sherburne and Oriskany Falls, N. Y.) *Above data total of plant.*
- UTICA SPINNING CO;** \$275,000; Quentin (**C**) McAdam, pres; John W. Allis, vice-pres; George E. Farrell, sec. and treas; P. B. Sanford, supt.; Hosiery Yarns; 30,000 spindles.
- UTICA STATE HOSPITAL;** Seamless Cot. (**K**) ton Hosiery; 10 knitting and 2 sewing machines; (buy yarn); sell direct to N. Y. State Hospitals, only.
- UTICA STEAM AND MOHAWK VALLEY COT. (C) TON MILLS;** A. G. Brower, pres.; Geo. De Forest, treas.; Henry F. Mansfield, supt.; H. D. Manley, asst. supt.; Sheets and Pillow Cases, and Cotton Yarns; Sheetings and Shirtings; 56,000 ring and 70,000 mule spindles; 2200 looms; 10 cotton combs; steam; Moss, Taylor & Co., N. Y., Boston, Phila. and Balto., s. agts. for Sheetings, etc.; Yarns sold direct; H. F. Mansfield, buyer.
- UTICA WASTE CO.;** Cotton and Wool (**C & W**) Waste.
- Valatie. J-18. K. & H. RR.**
- HALL & CLARK MFG. CO.** *All machinery sold. Out of business.*
- VALATIE COTTON MILL;** W. A. Harder, (**C**) prop.; H. E. Brann, supt; Knitting Yarns and Men's Ribbed Underwear; 12,000 ring spindles; 30 knitting machines; steam and water; dye; sell direct; W. A. Harder and H. E. Brann, buyers.
- VALATIE KNITTING CO;** \$40,000; W. A. (**K**) Harder, pres; James F. Cowee, treas.; L. A. Pitcher, sec; Fleece Lined Underwear; 4 sets; 30 knitting and 50 sewing machines; steam; sell direct; 43 Leonard St., N. Y.
- WILD MFG. CO;** \$75,000; Chas. Wild, pres. (**C**) and treas; Wm. H. Wild, sec. and supt; Print Cloths; 6,100 ring and 5,900 mule spindles; 282 looms; steam and water; sell direct. *Shut down indefinitely.*
- Valley Falls. G-19. B. & M. RR. Fitch Div.**
- THOMPSON, JAS. & CO.;** Valley Falls (**C & F**) Flax Mills, Jas. Thompson, supt; Flax and Hemp Twine, Mosquito Nettings, Tarletans and Buckrams; 196 looms; water and steam; dye; sell direct. (Buy cotton warps, 8, 10, 30, 50, 60, 90, 100s; cops, 10, 10/2, 32, 50, 70, 85s.)
- Victory Mills. G-18. F. RR, Western Div.**
- SARATOGA VICTORY MFG. CO;** \$400,000; **C** James Lawrence, pres; Louis Robeson (Boston), treas; Ariel C. Thomas, agt.; Cotton Goods; 23,344 ring and 23,796 mule spindles; 1050 looms; steam and water; Catlin & Co., N. Y., s. agts; Louis Robeson, buyer.
- Wappinger's Falls. M-18. N. Y. C. & H. R. RR, Hudson Riv. Div.**
- DUTCHESS COMPANY;** (Inc.) John (**P & D**) Bogle, mgr. and supt; Cotton Printing and Dyeing; steam and water; Garner & Co., N. Y., s. agts.; James A. Rich, buyer.
- Warrensburg. E-18. N. Y. C. & H. R. RR**  
Lockport Br; N. Y., L. E. & W. RR, Lockport Br.
- WARRENSBURG WOOLEN CO.;** (not inc.); (**W**) (Successors to Whitley & Co. Woolen Mill); Milton N. Eldredge, supt; All Wool Cassimeres and Trousers; 2 sets; 7 looms; water; dye; sell direct; Milton Eldredge, buyer.
- Warsaw. H-7. Erie RR; B. R. & P. RR.**
- WARSAW KNITTING MILLS;** \$50,000; J. B. (**K**) Crossett, pres; John Hannigan, treas; Men's, Women's and Children's Hosiery; steam; dye; sell direct and through agents.
- Warwick. N-17. L. & H. R. RR.**
- FABRIC FIRE HOSE CO;** \$100,000; W. T. (**C**) Baird, treas; W. T. Cole, gen. mgr; Fred L. Brown, supt; Cotton Fire Hose; 30 looms; steam; sell direct; N. Y. office, 68 Murray St.
- Waterford. H-18. D. & H. RR, Saratoga Div.**
- CLOVER KNITTING CO;** \$60,000; Thomas (**K**) Breslin, pres; J. H. Pynes, treas; D. B. Keeler, supt; Men's, Ladies' and Children's Wool, and Men's Wool Flat and Fleece Underwear; 9 sets; 45 knitting machines; water and steam; dye; D. B. Keeler, buyer.
- FORD MFG. CO;** \$25,000; J. W. Ford, pres. (**K**) and treas; I. F. Green, supt; Children's and Men's Ballbriggan Fleece-lined Underwear; 45 knitting machines; steam; dye; sell direct; J. W. Ford, buyer. (Buy 8 to 30 yarns.)
- HIMES UNDERWEAR CO.** See Cohoes.
- KAVANAUGH KNITTING CO;** \$25,000; C. H. (**K**) Kavanaugh, pres. and supt; L. Kavanaugh, treas; F. W. Kavanaugh, sec; Ballbriggan Knit Underwear; 96 knitting machines; steam; dye; sell direct; C. H. and F. W. Kavanaugh, buyers.
- MASSASOIT KNITTING MILLS;** E. G. (**K**) Munson; W. B. Cook, supt; Wool and Merino Fleece-lined Underwear and Wool Overshirts and Jersey Ribbed Underwear; also Men's "U-Need-Me" Coats; 7 sets; 26 knitting and 50 sewing machines; steam and water; dye; sell direct. (P O. address Cohoes.) *Shut down.*
- McLOUGHLIN SILK CO.** *Out of business.*
- NOVELTY KNITTING UNDERWEAR CO;** (**K**) Ribbed Underwear; 24 knitting machines; steam; dye; E. L. Goodrich, 346 Broadway, N. Y., s. agt.
- ORMSBY TEXTILE CO;** \$75,000; Thos. Bres. (**K**) lin, pres; Chas. C. Ormsby, treas; Thos. F. Morris, supt; Wool and Cotton Underwear; 5 sets; 35 knitting machines; steam; dye; sell direct. (Buy 10 and 26 yarns.)
- PYNES, J. H.;** Eureka Knitting Mills; (**K**) Thos. Pynes, supt; Cotton, Wool and Ballbriggan Underwear; 8 sets; 55 cylinders; steam; dye; sell direct; Room 936, N. Y. Life Bldg., N. Y.; Thos Pynes, buyer.
- WATERFORD DYE WORKS;** 73 Third St; (**D**) James A. Ranney, prop; Fast Colors of all Shades, Cotton and Wool for Mixtures; Skeins and Garments dyed for the trade.
- WATERFORD KNITTING CO;** \$50,000; Thos. (**K**) Breslin, pres. and treas.; Wool Underwear; 7 sets; 43 cylinders; steam and water; dye; sell direct; 348 Broadway, N. Y.
- Waterloo. H-10. N. Y. C. & H. R. RR,**  
Auburn Br.
- WATERLOO WOOLEN MFG. CO;** \$150,000; (**W**) Wm. Greenough, pres; E. J. Rogers, sec; H. L. Battery, supt; Woolen Cloths and Shawls, Overcoatings, Carriage and Uniform Cloths; 25 sets; 128 looms; steam and water; dye; Patterson & Greenough, 345 Broadway, N. Y., s. agts.

**Watertown.** D-13. R. W. & O. RR.

LANCE, GEO. A.; Watertown Woolen (W) Mills; Woolen Yarns for Knitting Purposes; 2 sets; steam and water; dye; sell direct.

VALEINE & BENTLEY SILK CO., THE; (S) (Also Newton, N. J. and Pittson, Pa.); Silk Fabrics; 162 looms; water.

**Watervliet.** (Formerly known as West Troy.) H-18. D. & H. RR., Saratoga Div.

ROY, JAS. & CO; Watervliet Mills; \$500,-(W) 000; Benj. Knowler, pres; John F. Roy, treas; John McLaren, supt; Woollens, Worsteds, Dress Goods and Carriage Cloths; 2 combs; 27 sets; 170 looms; steam; dye; Cooley, Turnbull & Co., N. Y., s. agts.

**Wegatchie.** C-13. R. W. & O. RR.

WRIGHT, H. K.; Church's Woolen Mill; (W) L. D. Brown, supt.; Coarse Medium Flannels and Yarns; 1 custom roll card; 2 sets; 8 looms; steam and water; dye; sell direct; H. K. Wright, buyer. (Buy white and gray, 2 1/4 to 3 run, coarse stock or combing wool stock.)

**Westbrookville.** M-17. P. J. M. & N. Y. RR.

ASHWORTH, J. E. & SONS; R. C. Ashworth, pres.; J. E. Ashworth, treas.; D. G. Ashworth, supt.; Woolen Blankets; 1 set; 4 looms; water; dye; sell direct; R. C. Ashworth, buyer.

**West Cornwall.** N-17. N. Y. O. & W. RR, Southern Div.

FIRTH CARPET CO; \$1,000,000; Thos. F. (W) Firth, pres; Bennet H. Tobey, treas.; Fred Booth, supt. and buyer; Tapestry and Brussels Carpets and Rugs; 6 sets; 3 combs; 3000 worsted pindless steam and water; dye; sell direct. (Buy worsted, cotton, jute and linen yarns, woolen yarns.) (P. O. Address Firthcliffe.)

**West Eaton.** H-13. N. Y. O. & W. RR, Northern Div.

WEST EATON WOOLEN MILLS; W. A. Fraser, prop. *Burned Feb., 1901.*

**West New Brighton.** P-17. S. I. RR, Erasmus Div.

EMPIRE STATE WOVEN LABEL CO; A. K. (S) Buhl; Silk and Linen Labels; 20 looms; steam; sell direct and through com. agts.

**West Park.** L-18. W. S. RR, Hudson River Div.

SHEFER, ROSSA; H. Shefer, agt; (C & W) Shoddy and Cotton Batts; 2 cards; 2 pickers; 1 cluster; water; sell direct.

**West Sand Lake.** H-19. Electric from Troy.

McLAREN, J. & R; Men's and Boys' (K) Knit Underwear and Over-shirts; 5 sets; 23 knitting machines; steam and water; dye; Bacon & Co, N. Y., s. agts.

**West Stockholm.** A-15. C. V. RR, Ogdensburg & Lake Champlain Div.

STAFFORD & CLARK; Cassimeres, Flannels, Etc; 1 set; 3 looms; water; dye.

**Whitehall.** E-19. D. & H. RR, Champlain Div.

CHAMPLAIN SILK MILLS; \$100,000; Aubrey (S) E. Meyer, pres, and treas.; E. J. Lowenstein, agt., supt. and buyer; Silk Yarns for Weaving and Knitting, Sewing Silk, Schappe; steam and water; dye; sell direct.

**Whitesboro.** F-15. N. Y. C. & H. R. RR, Buffalo & Niagara Falls Br.

ABLETT, ROBT; Anchor Knitting Mills; (K) Men's and Children's Fleece-lined and Flat Underwear; 5 sets; 2100 spindles; 42 knitting machines; 60 sewing machines; steam; sell direct; N. Y. office, 256 Church St., Room 58.

ALLIANCE KNITTING MILLS; Chas. A. (K) Powell; Ladies' and Children's Ribbed Goods; 100 knitting machines; 85-sewing machines; steam; sell direct; N. Y. office 58 Watson Bldg., 256 Church St.

**Whitestone.** P-18. (Not shown on map.) L. I. RR.

SCHWARZE, JULIUS; Silk Ribbons and (S) Silk and Mohair Braids.

**Yonkers.** O-18. N. Y. C. & H. R. RR, Hudson River Div; N. Y. & P. RR, Yonkers Br.

SHAUGHNESSY, JAMES W.; Ribbons; 20 (S) looms; steam; sell direct.

SMITH, ALEXANDER & SONS CARPET CO; (W) \$300,000; E. T. Holder, pres; Richard Edie, Jr, treas; Alex. Smith Cochran; see; E. C. Clark, supt; Axminster, Velvets, Tapestry, Brussels, Moquette Carpets, 157 sets; 22 combs; 32,760 spindles; 958 looms; steam; dye; sell direct.

## NORTH CAROLINA.

See map on page 186.

For explanation of abbreviations see page 66.

**Albermarle.** B-5. S. RR.

EFIRD MFG. CO; \$200,000; J. W. Cannon, (C) pres; J. S. Efird, treas; J. D. Bacon, supt; Hosiery Yarns; 10,000 spindles; steam; dye; sell direct; C. J. Webb & Co, s. agts; J. S. Efird, buyer.

WINDEMERE KNITTING MILL; \$25,000; J. (K) W. Cannon, (Concord) pres; J. C. Leslie, treas; A. L. Patterson, supt; Hosiery; 150 knitting machines; steam; sell direct; J. C. Leslie, buyer. (Capacity 150 doz. pair per day.)

WISCASSETT MILLS CO; \$300,000; J. W. (C) Cannon, pres; John C. Leslie, treas; T. M. Denning, supt; Hosiery Yarns, Warps, etc; 20,000 spindles; steam; sell direct and C. J. Webb & Co, s. agts.

**Asheville.** B-3. S. R'y. Co.

ASHEVILLE COTTON MILLS; \$250,000; C. (C) sar Cone, pres.; D. G. Devenish, treas. and agt; John Gilligan, supt; Plaids, Hickory Stripe Chambray, Ticking and 14s Yarn; 8500 spindles; 450 looms; steam; dye in raw stock and yarn; Cone Export & Com. Co., N. Y., s. agts.; D. G. Devenish, buyer. (Buy 22s warp.)

WHITMAN TEXTILE CO., THE; \$25,000; (C) (\$250,000 authorized); Henry Redwood, pres; W. T. Weaver, treas.; William Whitman, Jr., supt.; Corduroys; 100 looms; electricity. (Expect to start up July 1st.)

**Belmont.** B-4. S. R'y. Co.

CHRONICLE MILLS, THE; \$75,000 (to increase to \$125,000); R. P. Rankin, pres.; R. L. Stowe, treas.; B. F. Houston, supt.; Yarns, 16 to 26s; 4,392 ring spindles; steam.

STOWESVILLE COTTON MILL. *Abandoned.*

**Bessemer City.** C-4. S. R'y. Co.

BESSEMER CITY COTTON MILLS; \$50,000; (C) J. A. Smith, pres. and buyer; Fine Sheetings. *Proposed.*

SOUTHERN COTTON MILLS; \$125,000; J. M. (C) Odell, pres; W. R. Odell, vice pres; S. J. Durham, sec. and treas; C. M. Cooke, supt; Brown Goods and Madras; 9,600 spindles; 404 looms; steam; dye; J. L. Baily & Co., s. agts.

**Burlington.** A-6. S. R'y. Co.

ALAMANCE FACTORY; E. M. Holt's Sons; (C) S. Homewood, supt; 5 and 6 yd; Plaids; 960 spindles; 94 looms; steam and water;



- sell direct and Farrish-Stafford Co. s. agts; Solomon Homewood, buyer. (5 miles from Burlington.)
- ACRORA COTTON MILLS;** Lawrence S. (C) Holt & Sons, prop; Gingham; 16,608 ring spindles; 748 looms; steam; dye; Joshua L. Baily & Co, N. Y. and Phila., s. agts.
- BURLINGTON HOSIERY MILLS;** \$6,000; G. (K) W. Fogleman, pres., treas. and mgr.; Cotton Seamless Half Hose; 176 needles; 18 knitting machines; sell direct. (Buy 10 to 40 cone yarn.)
- CAROLINA COTTON MILLS;** \$60,000; L. (C) Banks Holt, pres; R. L. Holt, treas; J. B. Waddell, supt. and buyer; Plaids and Yarns; 3072 spindles; 58 looms; water; dye; sell direct; R. L. Holt, buyer.
- DAISY HOSIERY MILLS;** Geo. W. An. (K) thony, pres; B. O. Guthrie sec. and treas.; J. A. Boland, supt; Seamless Hosiery; 30 knitting machines; steam; dye; Hunter Mfg. & Com. Co., s. agts.
- ELMIRA COTTON MILLS;** W. L. Holt, (C) pres; R. L. Holt, sec. and treas; H. C. Fowler, supt; Checks and Plaids; 5,000 spindles; 460 looms; steam; dye in raw stock; Willson & Bradbury, N. Y., s. agts. (Buy 22, 26, 30 yarn.)
- GLENCOE COTTON MILLS;** \$120,000; W. E. (C) Holt, pres; R. L. Holt, treas and mgr; Plaids, Chevots, Domets, Stripes and Cottonades; 3,962 ring spindles; 200 looms; water; dye; Clark & Campion, N. Y., s. agts. R. L. Holt, buyer.
- HOLT, E. M., PLAID MILLS;** L. Banks (C) Holt, pres; Lynn B. Williamson, treas, agt. and buyer; J. M. Fowler, supt; Fine Shirtings; 140 looms; steam; dye. (Buy cotton 26/1 warp and skein and 40/1 warps.)
- HOLT, R. L. & J. H., JR.;** Windsor Cotton (C) Mill; J. H. Holt, Jr, Mgr; Checks, Plaids and Stripes; 3100 spindles; 160 looms; steam; dye; Wilson & Bradbury, Phila., Dudley, Battelle, Hurd, & Co., N. Y., s. agts.
- JUANITA COTTON MILLS;** office, Raleigh; (C) \$40,000; E. B. Barbee, pres.; G. Rosenthal, treas. and buyer; E. W. Worth, supt; Cotton Yarns; 6200 spindles; steam and water; sell direct and Jas. E. Mitchell & Co., Phila., s. agts.
- LAKESIDE MILLS;** E. C. Holt, pres.; J. H. (C) Holt, treas.; Gingham; 3,200 ring spindles; 150 looms; steam; dye; Holt Mills, N. Y., s. agts.
- Hynum.** B-7. S. A. L. RR.
- ODELL, J. M., MFG. Co.;** J. M. Odell, (C) pres; W. R. Odell, Concord, treas; J. W. Atwater, agt; C. P. Emery, supt; Cotton Skein Yarn; 6000 spindles; water; sell direct and Wm. D'Oliver & Co. Phila., s. agts. J. W. Atwater, buyer. (RR. station, Pittsboro.)
- Cameron.** E-5. S. Air Line, C. RR.
- CAMERON COTTON MILL CO.;** \$50,000; J. (C) W. Scott, pres.; W. G. Robertson, sec., treas. and gen'l mgr.; Yarns, 6s to 12s; 1,800 ring spindles; steam.
- Caroleen.** B-4. S. A. Line.
- HENRIETTA MILLS.** (Branch mill.) See (C) Henrietta.
- Cedar Falls.** B-6. C. F. & Y. V. RR.
- CEDAR FALLS MFG. CO.;** \$100,000; A. F. (C) Cox, pres.; O. R. Cox, treas. and supt.; 40-inch Brown Sheetings and Yarns; 3,936 ring spindles; 136 looms; water and steam; Catlin & Co., N. Y., s. agts.; O. R. Cox, buyer. (Two mills.)
- Central Falls.** B-6. C. F. & Y. V. RR.
- WORTH MFG. Co.;** (Mill No. 2); Frank H. (C) Congdon, supt; Colored Cottons and Yarns, 6s to 24s; 4,256 ring spindles; 154 looms; steam and water; dye; Farris-Stafford Co., N. Y., s. agts. for goods; sell yarns direct. (See main mill No. 1 at Worthville.)
- Chapel Hill.** B-7. S. RR.
- BLANCH HOSIERY MILLS CO.;** \$15,000; (K) W. R. Lloyd, pres.; W. E. Lindsay, treas. and agt.; Lee Moore, supt.; Men and Women's Hosiery; 176 needles; 25 knitting machines; steam; sell direct and Fred'k Victor & Achelis, s. agts.; W. E. Lindsay, buyer.
- LOYD, THOMAS F.;** Yarns, 16s to 24s; 5000 (C) spindles; steam.
- Charlotte.** B-5. S. R'y Co.; S. A. L. RR.
- ADA MFG. CO.;** \$128,600; Dr. Jos. Graham, (C) pres.; David Clark, treas. and gen'l mgr; W. L. Robbins, supt; 8/3 to 20/2 Yarns; 8000 spindles; steam; sell direct and through agts; David Clark, buyer.
- ATHERTON MILLS;** \$175,000; D. A. Tomp. (C) kins, pres.; Geo. L. Krueger, treas; R. M. Miller, Jr, vice-pres; J. M. Beaty, sec; J. M. Smyly, supt.; 26 to 50 Two ply yarns; 10,000 ring spindles; steam; sell direct; J. M. Beaty, buyer.
- BARNHARDT MANUFACTURING Co.;** \$50, (C) 000; Dr. C. A. Misenheimer, pres.; Thos. M. Barnhardt, sec. and treas; Jas. McDonald, supt; Cotton Batting of all kinds; steam; sell direct; Thos. M. Barnhardt, buyer.
- CHADWICK MFG. CO.;** \$260,000; E. A. (C) Smith, pres; E. C. Dwell, sec. and treas.; H. H. Boyd, supt.; Sheetings; 12,200 ring spindles; 300 looms; steam; Carey, Bayne & Smith Co., s. agts.; E. C. Dwell, buyer.
- CHARLOTTE CORDAGE Co.;** (formerly O. (C) A. Robbins Co.) \$25,000; J. L. Sexton, pres. and treas; Cotton Yarns and Braided Goods; 2020 ring spindles; 85 braiders; steam; J. L. Sexton, buyer.
- CHARLOTTE COTTON MILLS;** \$131,500; J. M. (C) Oates, pres; D. W. Oates, treas. and buyer; Thomas W. Harvey, supt; Fancy Colored Shirtings; 10,000 ring spindles; 144 broad and 104 narrow looms; steam; Eldridge, Lewis & Co., N. Y., s. agts.
- CHARLOTTE OIL & FERTILIZER Co.;** \$200, (C) 000; Fred Oliver, pres., treas. and buyer; Geo. Swisher, supt; Cotton Batts; 10 garnets; steam; sell direct. *Going out business.*
- CROWLEY'S MILLS;** M. T. Crowley, prop; (C) J. H. Crowley, supt. and buyer; Terry Cloth, Crashes and Towels, 120 looms; steam; Whitman & Phelps, N. Y. s. agts.
- DOVER YARN MILLS;** \$90,000; E. A. (C) Smith, pres.; J. P. Wilson, treas.; John B. Boyd, supt.; Yarns, 30 to 40, 2 and 3 ply; 5376 spindles; steam; W. M. & F. W. Sharples & Co., Phila., s. agts. (RR. station, Pineville.)
- ELIZABETH MILLS, THE;** \$100,000; R. M. (C) Miller, Jr., pres. and treas; Vinton Liddell, vice-pres; J. W. Miller, sec; J. H. Hamilton, supt.; 40/2 to 60/2 Combed and Carded 2 ply Yarns; 5,000 ring spindles; 3,000 twister spindles; steam; R. M. Miller, Jr., buyer.
- GOLD CROWN HOSIERY MILLS;** (Sold spinning plant.) *See Zirconia.*
- HIGHLAND PARK MFG. CO.;** \$200,000; Wm. (C) E. Holt, pres.; C. W. Johnston, treas; C. H. Branson, supt; Domino Gingham; 13,500 spindles; 1260 looms; steam; dye; Fred'k. Victor & Achelis, s. agts. (Also Rock Hill, S. C.)
- LOUISE MILLS;** \$200,000; J. P. Wilson, (C) pres; W. S. Mallory, treas; Jno. B. Boyd, supt; Convertables; 20,000 ring spindles; 600 looms; steam; Carey, Bayne & Smith Co., N. Y., s. agts.
- MAGNOLIA MILLS;** A. C. Summerville, (C) prop; Fine Splicing Yarns; 3,072 spindles; steam; Wm. D'Oliver & Sons, s. agts.
- MARGOLIUS & Co.;** Jute Bagging. (Also (J) Norfolk, Va.)



# S. S. GETCHELL & SON, Woonsocket, R. I.

## FRAME AND MULE CYLINDERS.

### ROLLS AND TIN PARTS for all kinds of Machinery.

**ORIENT MFG. Co.;** \$200,000; H. D. Wheat, (C pres. and treas.; J. G. Wardlow, sec.; B. A. Holmes, supt.; Yarns, 24 to 40s, Print Cloth, Dobby Weaves, etc.; 13,416 ring and 3,000 twister spindles; 340 looms; steam; sell yarns direct; Carey, Bayne & Smith Co., N. Y., sell cloths; H. D. Wheat, buyer. (Formerly Alpha Mills.)

**VICTOR COTTON MILLS;** \$150,000; Geo. (C E. Wilson, pres; J. M. Sharpe, sec. and treas.; J. B. Hawkins, supt.; Cotton Yarns; Nos. 20 to 30; 12,672 spindles; steam; J. E. Mitchell & Co, Phila. and Boston, s. agts; sec. and treas. buyers.

#### **Cherryville.** B-4. S. A. L. RR.

**CHERRYVILLE MFG. Co.;** \$100,000; S. S. (C Mauney, pres.; John J. George, sec. and treas.; H. D. George, supt.; Cotton Yarns, 20s to 40s; 6000 spindles; 40 cards; steam; W. M. & F. W. Sharples, Phila. s. agts.; John J. George, buyer.

**GASTON MFG. Co.;** \$126,200; J. H. Hull, (C pres.; D. P. Rhodes, treas. and supt.; 40s Yarns and Fine Sheetings; 6,656 spindles; 192 looms; steam; Catlin & Co., s. agts.; D. P. Rhodes, buyer.

**VIVIAN COTTON MILLS;** \$30,000; S. S. (C Mauney, pres.; J. C. Ballard, agt. and supt.; Twisted Yarns, ss to 16s reeled; 1,632 ring spindles; steam; Buckingham, Paulson & Co. and Catlin & Co., s. agts.

#### **China Grove.** B-5. S. R'y Co.

**LINN MILLS Co.;** \$80,000; D. B. Coltrane, (C pres. and agt.; C. W. Corlier, treas.; Geo. O. Lipe, supt.; Yarns, s to 16, 2 to 8 ply; 3,500 ring spindles; steam; dye; D. B. Coltrane, buyer.

**PATERSON MANUFACTURING Co.;** \$165,000; (C J. W. Cannon, pres.; W. J. Swink, sec. and treas.; T. L. Ross, supt.; Sheetings and Hosiery Yarns, 8 to 30s; 9296 ring spindles; 158 looms; steam; Catlin & Co., N. Y., s. agts. for cloth; C. J. Webb & Co., Phila., yarns.

#### **Claremont.** B-4. (Not shown on map.) Sou. Ry.

**CLAREMONT COTTON MILL;** \$150,000; J. W. (C Setzer, J. T. Sigmon and W. F. White, interested. *Proposed.* (Will start work this year.)

#### **Clayton.** B-7. Sou. Ry.

**CLAYTON COTTON MILL;** \$120,000; Ashley (C Home, pres.; L. D. Debnam, sec. and treas.; Yarns, 18s to 30s; 5,000 ring spindles; steam.

#### **Clifftop.** See *Henritilla.*

#### **Coleridge.** B-6. C. F. & Y. V. RR.

**ENTERPRISE MFG. Co.;** \$25,000; D. H. (C Lambert, pres.; James A. Cole, treas. and agt.; W. W. McIntosh, supt.; Cotton Yarns, Single and in Plys; 7500 spindles; water and steam; sell direct; James A. Cole, buyer. (RR. station, Ramsour, seven and one-half miles distant.)

#### **Concord.** B-5. S. R'y Co.

**BALA COTTON MILLS;** E. C. Barnhardt, (C pres; J. F. Cannon, treas.; Yarns, 24s to 40s, skein, beam and chain warps; 3080 spindles; steam; sell direct; J. F. Cannon, **CABARIUS COTTON MILL;** \$150,000; D. F. (C Cannon, pres; J. W. Cannon, treas;

C. M. Sather, supt; Brown Sheetings; 8,500 spindles; 542 looms; steam; sell direct. (Buy 22 to 26 single yarn on beams)

**CANNON MANUFACTURING Co.;** \$200,000; (C D. F. Cannon, pres.; J. W. Cannon, treas.; J. C. Matthews, supt.; J. W. Cannon, buyer; Yarns and Sheetings; 23,100 spindles; 850 looms; steam; sell direct and Catlin & Co., s. agts.

**COLEMAN MFG. Co.;** \$100,600. R. B. Fitz-(C gerald, pres; W. C. Coleman, sec. and treas.; H. E. Smith, supt.; Sheetings and 20 to 30s Yarns; 5230 spindles; 140 looms; steam; W. C. Coleman, buyer.

**GIBSON MFG. Co.;** \$275,000; J. W. Cannon, (C pres.; R. E. Gibson, sec. and treas.; A. J. Rose, supt.; Blankets and Yarns; 14,976 ring spindles; 106 looms; steam; sell direct; E. C. Barnhardt, buyer.

**HARRIS MFG. Co.;** \$100,000; J. W. Cannon, (C pres; B. E. Harris, sec. and treas. *Proposed.* *Not yet organized.* Mar. '02.

**KERR BAG MFG. Co.;** J. M. Odell, (F & B) pres; W. R. Odell, treas; Robt. Wheeler, supt; Cotton Goods Finishers; Bleachery; Capacity, 40,000 yds. per day.

**LIPPARD YARN MILL;** \$12,500; J. C. Lip, (C pard, pres; J. B. Sherrill, treas; J. C. Odell, supt; 142 ply Yarns; 1,320 ring spindles; steam; J. B. Sherrill, buyer.

**ODELL MANUFACTURING Co.;** \$500,000; J. (C M. Odell, pres.; W. R. Odell, treas.; F. L. Emery, supt.; Gingham, Domets, Sheet- ing, Seamless Bags, Etc.; 30,000 ring spindles; 1726 looms; steam; dye and bleach; Joshua L. Baily & Co., Phila. & N. Y., s. agts. Also operate Buffalo Thread Mill.

#### **Coolceemee.** B-5. So. Ry.

**COOLEEMEE COTTON MILLS;** (Coolceemee (C Falls); \$300,000; W. A. Erwin, pres; J. H. Webb, sec. and treas; L. A. Abercrombie, supt; Standard Sheetings and Drills; 35,000 spindles; 800 looms; steam and water; Joshua L. Baily & Co., s. agts. and sell direct; W. A. Erwin and J. H. Webb, buyers.

#### **Cumberland.** C-7. A. C. L. RR.; C. F. & Y. V. RR.

**CUMBERLAND COTTON MILLS Co.;** \$125, (C 600; W. D. Allen, vice-pres. and buyer; J. B. Driver, supt; Warp and Skein Yarns; 3,000 spindles; steam and water; sell through agents. (RR. Station Hope Mills, 2 miles.)

#### **Dallas.** B-4. S. R'y Co.

**DALLAS COTTON MILLS;** \$65,000; L. M. (C Hoffman, pres.; E. L. Wilson, treas; Jas. Downum, supt.; Sheetings and 1s/2 to 30/2 Warps and Skein; 4160 spinning and 1056 twisting spindles; 116 looms; steam; Robinson & Shackleton, N. Y. and Chas. J. Webb & Co, Phila, s. agts; E. L. Wilson, buyer.

#### **Davidson.** B-5. S. R'y Co.

**CORNELIUS COTTON MILLS;** \$75,000; J. B. (C Cornelius, pres.; P. A. Stough, treas; T. H. White, supt.; Chambrays and Colored Goods; 5300 ring spindles, 120 looms; steam; dye; sell direct; P. A. Stough, buyer.

- LINDEN MANUFACTURING Co ; \$45,000; J (C) P. Munroe, pres ; F. J. Knox, treas.; W. L. Saunders, supt.; 2 and 3 ply Skein Yarns, 24s to 30s; 574 spindles; steam; Eddy & Street, s. agts.
- Double Shoal.** B-4. O. R. & C. RR.; S. A. L. RR.
- DOUBLE SHOAL COTTON MILLS; \$50,000; (C) Fred R. Morgan, pres.; E. A. Morgan, treas., supt. and buyer; Carpet Warps, Twines, Etc.; 3,400 spindles; water; Jas. E. Reynolds & Co., s. agts. (RR station, Shelby, eight miles distant.)
- Durham.** A-7. S. A. L. RR.; S. R'y. Co.; N. & W. RR.
- COMMONWEALTH COTTON MFG. CO., THE; (C) \$250,000; B. L. Duke, pres.; J. E. Pugh, treas.; O. W. Stiles, supt.; Hosiery and Underwear Yarns in Mixtures and Colors; 7,000 ring spindles; steam; dye; sell direct.
- DURHAM COTTON MFG. Co. See East Durham.
- DURHAM DYEING Co. Rudolph Knoffner, (D) mgr.; Fast Black on Skein Yarn and Hosiery, Lisle Thread Finish, Black and all Colors on Knit Goods and Yarn.
- DURHAM HOSEY MILLS; \$500,000; J. S. (K) Manning, pres.; J. S. Carr, Jr., treas.; C. D. Partin, supt.; Men's and Ladies' Cotton Seamless Hosiery and Hosiery Yarns; 8,000 spindles; 300 knitting machines; steam; dye; sell direct; L. C. Vaughan, 346 Broadway, N. Y., agt.; J. S. Carr, Jr., buyer.
- ERWIN COTTON MILLS Co, THE, \$350,000; (C) B. N. Duke, pres.; G. W. Watts, vice-pres., W. A. Erwin, sec. and treas.; Cambrics, Denims and Chambrays; 25,088 spindles; 926 looms; steam; dye and finish; Joshua L. Baily & Co., N. Y. and Phila., s. agts.
- GOLDEN BELT MFG. Co; \$500,000; T. B. (C) Fuller, pres. and treas.; A. C. Haskell, Jr., supt.; Sheetings and Tobacco Bags; 16,000 ring spindles; 400 looms; steam in cotton mill; electricity, bag mill; sell direct; T. B. Fuller and A. C. Haskell, Jr., buyers.
- East Durham.** B-7. S. R'y. Co.
- DURHAM COTTON MFG. Co.; \$300,000; W. (C) A. Erwin, pres.; J. Harper Erwin, treas.; Y. E. Smith, supt.; Brown Sheetting, Domets, Shirts and Chambrays; 23,500 spindles; 692 looms; steam; dye raw stock and yarn; J. L. Baily & Co, s. agts.; J. Harper Erwin, buyer.
- PEARL COTTON MILLS; \$175,000; G. W. (C) Watts, pres.; J. H. Erwin, treas.; J. F. Broadway, supt.; Wide Sheetings, 44 to 99 inches; 10,336 spindles; 210 looms; Joshua L. Baily & Co., 19 Thomas St., N. Y. and Phila., s. agts.; J. H. Erwin, buyer. (Mill at Durham.)
- Edenton.** A-10. N. & S. RR.
- EDENTON COTTON MILLS \$100,000; Frank (C) Wood, pres.; Lawrence McKrae, treas.; 24/2 26/2 Warps and Skeins; 6,272 ring spindles; steam. D'Oliver & Loeb, Phila., s. agts.; L. McKrae, buyer.
- Elizabeth City.** A-10. N. & S. RR.
- ELIZABETH CITY COTTON MILLS; \$100,000; (C) O. McMullan, pres.; James G. Gregory, treas.; H. F. Smith, supt.; Warps and Skeins, single and ply; 10,000 ring spindles; steam; James E. Mitchell & Co., Phila., s. agts.; treas. or supt., buyers.
- ELIZABETH CITY KNITTING MILLS; \$25, (K) 000; P. H. Williams, pres.; R. B. Martin, treas.; H. E. Wilson, supt.; Women's and Men's Hosiery; 33 knitting machines; steam; dye; sell direct and Dresser & Co., s. agts.; P. H. Williams, buyer. (Buy Am. mule spun, nos. 9, 12, 24; combed Egyptian, 36/2, 36/3.)
- Elkin.** A-5. S. R'y. Co.
- CHATHAM MFG. Co.; \$50,000; A. Chat. (W&C) ham, pres.; H. G. Chatham, treas.; G. T. Roth, supt.; Blankets a Specialty; Cas-  
simeres and Yarns; 5 sets; 60 looms; steam; dye; sell direct; H. G. Chatham, buyer.
- ELKIN MFG. Co.; A. M. Smith, pres.; (K) Thos. J. Lillard, treas. (Spinning mill sold to Chatham Mfg. Co.) *Propose building a knitting mill under same name.*
- Enfield.** A-8. A. C. Line.
- ENFIELD KNITTING MILL; \$10,000; Dr. (K) John A. Collins, pres.; E. N. Ricks, treas.; Geo. W. Kersey, supt.; Misses' and Children's Ribbed Hosiery; 31 knitting machines; steam; dye; Bloomer, Hughes & Co., N. Y., s. agts.
- Elon College.** A-6. S. R'y. Co.
- HOLT, GANT & HOLT; Altamahaw Cot. (C) ton Mills; James C. Reid, supt.; Cotton Cloths; 6500 spindles; 324 looms; steam and water; dye; L. Q. Gant, buyer.
- WILLIAMSON, JAS. N., & SONS; Ossipee (C) Cotton Mills; Jas. N. Williamson, Jr., mgr.; Jos. Hammill, supt.; Domets, Guinea Cloth, etc.; 4,000 spindles; 342 looms; steam and water; dye; Cone Export & Commission Co., N. Y., and Greensboro, N. C., s. agts.; J. N. Williamson, Jr., buyer.
- Fayetteville.** C-7. A. C. L. RR.; C. F. & Y. V. RR.
- ASHLEY & BAILEY Co; (109 and 111 (S) Spring St. N. Y.); Dwight Ashley, pres.; T. W. Thurston, supt.; Weaving and Spinning; 15,000 spindles; 1200 looms. (Also Paterson, N. J. Coatsville, Columbia, Marietta and York, Pa.)
- FAYETTEVILLE COTTON MILLS; \$50,000; (C) Charles Haigh, pres.; J. A. Byrne, sec. and treas.; A. I. McDonald, supt.; Warp and Skein Yarns; 1 to 20 single and ply; 3120 ring spindles; water and steam; Jas. E. Mitchell & Co., Phila. and Boston, s. agts.; J. A. Byrne, buyer (Reported sold under foreclosure. April, 1902.)
- HOLT MORGAN MILLS; W. L. Holt, pres.; (C) L. A. Williamson, sec.; W. M. Morgan, treas.; Yarns, Ticks, Ginghams, Drills and Sheetings; 10,000 ring spindles; 300 looms; steam; dye; Wilson & Bradbury, N. Y. & Phila., s. agts.
- HOLT-WILLIAMSON MFG. Co; \$80,000; (C) Walter L. Holt, pres.; Herbert Lutterloh, vice-pres.; E. H. Williamson, sec. and treas.; Geo. C. Simpson, supt.; Cotton Yarns; 5000 ring spindles; steam; Buckingham, Paulson & Co., s. agts.; E. H. Williamson, buyer.
- LAFAYETTE KNITTING MILL Co; \$10,000; (K) H. M. Pemberton, pres.; W. S. Cook, treas.; L. F. Knight, supt.; Misses' and Children's Ribbed Hose; buy 10s and 30s yarns; 37 machines; water; sell direct and through agents.
- TOLAR HART & HOLT MILLS; \$134,000; W. (C) L. Holt, pres.; E. W. Nolley, sec. and treas.; C. D. Duffer, supt.; Hosiery Yarn; 10,944 ring spindles; steam; Buckingham, Paulson & Co., s. agts.; E. W. Nolley, buyer.
- Flat Rock.** B-3. S. R'y. Co.
- HART MFG. Co.; \$25,850; A. R. Genard, (K) pres.; P. W. Hart, treas.; I. Cozzens, agt.; Arthur R. Genard, Jr., supt.; Cotton Half Hose; 78 knitting machines; steam; dye; Wm. Iselin & Co, s. agts.; P. W. Hart, buyer.
- Forest City.** B-3. O. R. & C. RR.; S. A. L. RR.
- FLORENCE MILLS; \$230,000; J. S. Spencer, (C) pres.; S. B. Tanner, treas.; E. J. Barnette, supt.; S. B. Tanner, buyer; Heavy and Fine Sheetings; 12,000 spindles; 350 looms; steam; Catlin & Co., s. agts.
- Franklinton.** A-8. S. A. L. RR.
- STERLING COTTON MILLS; \$100,000; S. C. (C) Yarn, pres. and treas.; D. M. Cook, supt.; Ball and Chain Warps, 12s to 22s, single

and 2 ply; 6240 ring spindles; steam; sell direct; S. C. Vann, buyer.

**Franklinville.** B.6. C. F. & Y. V. RR.

FRANKLINVILLE MFG. Co.; \$80,000; Hugh (C) Parks, pres.; B. Moffitt, treas.; W. C. Russell, supt.; Seamless Bags; 3,472 ring spindles; 90 bag looms; steam and water; dye; E. H. Hamilton & Co., N. Y., Jas. E. Mitchell & Co., Phila., s. agts; Benj. Moffitt, buyer.

RANDOLPH MFG. Co.; \$2,000; Hugh (C) Parks, Jr., pres. and treas.; D. S. Sumner, supt.; 4/4 3/8 3 yd. Sheetings; 4000 spindles; 128 looms; water and steam; Catlin & Co., N. Y., s. agts.; Hugh Parks, agt. and buyer.

**Gastonia.** B.4. S. Ry Co.; C. & L. RR.

ARLINGTON COTTON MILLS, THE; \$130,000; (C) 000; G. W. Ragan, pres. treas. and agt; Eugene Cross, supt; Yarns, 40s to 60s, One, Two and Three Ply; 6,272 ring spindles; steam; W. M. & F. W. Sharples, s. agts.; G. W. Ragan, buyer.

AVON MILLS; \$200,000; Geo. A. Gray, pres. (C) and mgr.; Jno. F. Love, treas.; J. L. Gray, supt.; Fine Cloths for Converting and Fine 2 Ply Yarn, 40s to 50s; 10,080 ring spindles; 300 looms; steam; Woodward, Baldwin & Co., N. Y. and J. E. Mitchell & Co., Phila., s. agts.

GASTONIA COTTON MFG. Co.; \$200,000; Geo. (C) A. Gray, pres., J. F. Love, treas.; Robert W. Gray, supt.; Brown Sheetings, Warps and Yarns, 20 to 50s; 12,000 ring spindles; 136 looms; steam; Woodward, Baldwin & Co., J. E. Mitchell & Co., s. agts.

LORAY MILLS; \$1,000,000; George A. Gray, (C) pres.; Jno F. Love, treas.; Chas. M. Dunn, supt.; Course Heavy Goods for Export Trade; 50,324 ring spindles; 1,680 looms; steam; Woodward, Baldwin & Co., N. Y., s. agts.; Geo. A. Gray, buyer.

MODENA COTTON MILLS; \$120,000; (C) L. L. Jenkins, pres.; J. D. Moore, treas.; J. O. White, supt.; Yarns and 37 5/8 Sheetings; 9000 spindles; 208 looms; steam; Chas. J. Webb & Co., Phila. and Robinson & Shackleton, N. Y., s. agts.

OZARK COTTON MILLS; \$150,000; Geo. A. (C) Gray, pres.; R. P. Rankin, sec. and treas.; J. P. Withers, supt; Fine Yarns; 8000 ring spindles; steam; Jas. E. Mitchell & Co., Phila., s. agts.

TREXTON COTTON MILLS; \$125,000; F. C. (C) Pogram, pres.; J. K. Dixon, treas.; T. C. Wilson, supt.; Cotton Yarns, 40/s to 60/s, one, two and three ply; 6400 ring spindles; steam; Jas. E. Mitchell & Co., Phila., s. agts.; T. C. Wilson, buyer.

**Gibsonville.** A.6. S. Ry Co.

HAWATHA MFG. Co; \$48,000; B. David (C) son, pres. and supt; W. H. Turrentine, treas; Warps and Hank Yarns; 3744 ring spindles; steam; sell direct.; B. Davidson and W. H. Turrentine, buyers.

MINNEOLA MFG. Co.; \$40,000; J. H. Cone (C) (Greensboro), pres; J. A. Davidson, treas; Stripes, Plaids and Checks; 2000 spindles; 300 looms; steam; dye; Cone Export & Com. Co., s. agts; see. and treas, buyers.

**Goldboro.** B.5. S. Ry Co.; A. C. L. RR.; A. & N. C. RR.

BORDEN MFG. Co; \$100,000; Frank K. (C) Borden, pres; E. B. Borden, sec. and treas; K. J. Davis, supt; Yarns; 6000 spindles.

WAYNE COTTON MILLS; \$75,000; Sol. Weil, (C) pres; E. B. Borden, Jr, sec. and treas; W. K. Parker, gen. mgr; Sheetings, Yarns and Warps; 4,200 spindles; 170 looms; steam; Wilson & Bradbury, Phila. and N. Y., s. agts.

**Graham.** A.6. S. Ry. Co.

HOLT, L. BANKS; Bellmont Cotton Mills; (C) Domestic; 2512 spindles; 123 looms; steam and water; dye in raw stock and yarn; Cone Export & Com. Co., s. agts; McBride Holt and L. B. Holt, buyers

ONEIDA COTTON MILLS; L. Banks Holt, (C) prop; Domestic, Fancy Dress Goods, Cottonades, etc; 12,000 ring spindles; 566 looms; steam; dye; Cone Export & Com. Co., Greensboro, and N. Y., s. agts; McBride Holt and L. B. Holt, buyers.

SIDNEY COTTON MILLS; \$40,000; W. C. (C) Donnell, pres.; J. L. Scott, Jr, treas and buyer; Geo. W. Albright, supt; Checks, Plaids, stripes; 108 looms; steam; dye; Cone Export & Com. Co., N. Y., s. agts. (Buy H to 16 yam.)

TRAVORA MFG. Co.; \$100,000; J. Harvey (C) White, pres.; W. Elliott White, treas.; Denims, Soft Yarns and Napped Goods; 2500 spindles; 100 looms; steam; dye; sell direct; White Bros., buyers.

VOORHEES MFG. Co.; \$25,000; J. V. Pomeroy, (C) eroy, pres.; T. O. Pomeroy, treas.; Fancy Cottons, Madras and Dress Goods; 100 looms; steam.

**Granite Falls.** B.4. C. & L. RR.

GRANITE FALLS MFG. Co; \$65,000; A. A. (C) Shuford, treas; J. M. Allred, supt; Carpet Warps, Nos. 7 and 8, in 3, 4 and 5 ply; 4000 ring spindles; water and steam; sell direct; treas. and supt., buyers.

RHOADS MFG. Co; \$300,000; George B. (C) Hiss, press; C. J. Rhodes, sec. and treas.;

## G. F. ALLISON & CO.,

UTICA, N. Y.

# Manufacturers of Wiping Waste.

... DEALERS IN ALL KINDS ...

## Cotton Waste.

Contracts made with Cotton and Knitting Mills for their yearly production of Waste.

J. M. Rhodes, agt. and supt.; Export Goods, Domestic and Drills; 15,000 ring spindles; 450 looms; water; Wilson & Bradbury, s. agts.; J. M. and C. J. Rhodes, buyers. (P. O. address, Rhodhiss).

**Greensboro.** A-6. S. Ry Co.; C. F. & Y. V. RR.

**COUTLER & LOWRY COMPANY;** \$150, (D & F 600); J. C. Lowry, pres.; H. H. Lowry, treas.; J. W. Lindan, agt.; Finishers of Cotton Goods; steam; 203.7 North 22d St, Phila. (Also plant at Phila.)

**HUCOMUGA MILLS;** \$20,000; J. W. Cone, (C pres.; C. N. Cone, treas.; J. H. Denny, supt.; Cotton Goods, Outings; 144 looms; steam; dye; Cone Export & Com. Co., N. Y., s. agts.; C. N. Cone, buyer. (Buy 22s warps and 12s filling 1 soft for napping.)

**PROXIMITY MFG. CO.;** \$200,000; Caesar (C Cone, pres.; B. N. Duke, vice-pres.; J. W. Cone, sec. and treas.; R. G. Campbell, supt.; Colored Cotton Goods; 18,000 ring spindles; 1000 looms; steam; dye; Cone Export & Com. Co., s. agts.; Caesar Cone, buyer.

**REVOLUTION COTTON MILLS;** \$300,000; (C E. Sternberger, pres.; H. Sternberger, sec. and treas.; J. W. Holt, supt.; Canton Flannels; 15,000 ring spindles; 376 looms; steam; Cone Export & Com. Co., s. agts.; H. Sternberger, buyer.

**VAN DEVENTER CARPET CO.;** A. J. (W Branson, pres.; A. V. D. Smith, sec. and treas.; Carpets and Rugs; 90 looms; steam; dye; sell direct and through agents; buy yarn.

**Greenville.** B-9. Atl. Coast Line.

**GREENVILLE COTTON MILLS;** \$250,000; (C J. G. Moye, pres.; R. L. Davis, vice-pres.; S. T. Hooker, sec. and treas.; Spinning and Weaving; 10,000 spindles. *Proposed.*

**GREENVILLE KNITTING MILLS;** \$20,000; (K L. L. Moore, pres.; W. S. Atkins, treas.; Men's Ribbed Underwear; 14 knitting machines; Critten, Clift & Co., s. agts.; W. S. Atkins, buyer. (Buy white and colors, no. 8 to 20.)

**Harden.** B-4. C. & L. RR.

**HARDEN MFG. CO.;** \$28,000; O. D. Carpen. (C ter, pres, treas. and supt.; 26/2 Ply Yarns; 2080 ring spindles; water; W. M. & F. W. Sharples, Phila. s. agts.

**Haw River.** A-6. S. Ry Co.

**CORA MFG. CO.** See Holt-Granite Mfg. Co.  
**GRANITE MFG. CO.** See Holt-Granite Mfg. Co.  
**HOLT-GRANITE MFG. CO.;** \$430,000; A. W. (C Haywood, pres.; E. C. Laird, vice-pres.; B. S. Robertson, sec. and treas.; J. Thompson, supt. No. 1 mill; W. J. Thompson, Nos. 2 & 3; Platts, Chambrays and Chev-iot-; 17,760 ring spindles; 863 narrow looms; dye and finish; steam; Cone Export & Com. Co., s. agts.; B. S. Robertson, buyer. (Cora Mfg. Co., Granite Mfg. Co. & Thos. M. Holt Mfg. Co., merged into one company.)

**HOLT, THOS. M., MFG. CO.** See Holt-Granite Mfg. Co.

**Henderson.** A. S. Seaboard Air Line; Suffolk & Carolina RR.

**HARRIET COTTON MILLS;** \$300,000; D. Y. (C Cooper, pres.; J. B. Owen, treas.; F. L. Page, supt.; Hosiery Yarns, 7 to 16; 10,500 ring spindles; steam; J. A. Burton, buyer.

**HENDERSON COTTON MILLS;** \$240,000; D. (C Y. Cooper, pres.; J. D. Rose, sec. and treas.; A. C. Allgood, supt.; Fine Brown Sheetings; 64x4.5-15.2 $\frac{1}{2}$ ; 15,000 ring spindles; 216 looms; steam; sell direct; J. D. Rose, buyer.

**SEABOARD KNITTING MILL;** \$90,000; (K J. P. Taylor, pres.; J. B. Owen, treas.; Oren C. Burt, sec. and gen. mgr.; Davie McGinniss, supt.; Men's Cotton Rib Underwear; 33 knitting machines; steam; dye; Wm. Isefin & Co, N. Y., s. agts.; O. C. Burt, buyer.

**Henrietta.** B-4. O. R. & C. RR.

**CLIFFSIDE MILLS;** (P. O. address Cliff (C side); B. D. Heath, pres.; R. R. Haynes, treas.; 5 yd. Goods and No. 20 Yarns; 10,000 spindles; 150 looms; water. (Expect to start June, '02.)

**HENRIETTA MILLS;** THE; \$700,000; J. S. (C Spencer, pres.; S. B. Tanner, treas. and buyer; Louis D. Duvat, supt.; 4yd. Sheetings, Print Cloths and Coarse Yarns; 75,000 ring spindles; 1872 looms; steam and water; Catlin & Co, N. Y., s. agts. (Also Caroleen.)

**Hickory.** B-4. Sou. Ry; C. & N. RR

**SHUFORD, A. A.;** O. M. Royster and K. (K C. Menzies; \$25,000. (Under construction.)

**SHUFORD MFG. CO.;** E. L.; \$135,000; E. W. (C Holbrook, pres.; E. L. Shuford, treas.; G. F. Ivey, supt.; Light Twills, Satens and Yarns, 20s to 40s; 7500 ring spindles; 200 looms; water; sell direct; E. L. Shuford, buyer.

**High Falls.** B-6. (Shipping point Halli-son), Junction D. & C. RR. and C. RR.

**HIGH FALLS MFG. CO.;** \$28,000; John W. (C Woody, pres.; Thos. N. Woody, treas.; S/L and 10/1 Chain Warps, also 8 and 10 Skeins, one, two and three ply; 202 ring spindles; water; sell direct and through agts.; Thos. N. Woody, buyer. (RR Station, Glendon.)

**High Shoals.** B-4.

**HIGH SHOALS CO.;** \$200,000; D. A. Tomp. (C kins, pres.; H. H. Westinghouse, vice-pres.; Geo. L. Kreuger, treas.; J. M. Beaty, sec.; Sheetings and Yarns, 20s to 26s, single; 5,000 ring spindles; 164 looms; water.

**Hillsboro.** A-7. S. RR.

**ENO COTTON MILLS;** \$100,000; A. J. Ruf. (C fin, pres.; Jas. Webb, Jr., treas.; Thos. N. Webb, supt. and buyer; 20/2 Warps and Skeins; 10,000 ring spindles; steam; sell direct and through agts.

**Hope Mills.** C-7. A. C. L. RR.

**HOPE MILLS MFG. CO.;** (333 Drexel Bldg, (C Phila.); W. C. Houston, Jr., pres.; Nicholas Lennig, vice-pres. and treas.; W. C. Houston, Jr., sec.; Frank H. Cotton, mgr.; Madras, Chevviots and Dress Goods; 12,582 spindles; 751 looms; water; dye; sell di-rect, Phila. office; W. C. Houston, Jr & F. H. Cotton, buyers.

**Hull's Cross Roads.** B-4 S. A. L. RR; O. R. & C. RR.

JENKS, T. PATE; See North Brook.

**Hunterville.** B-5. S. Ry Co.

**ANCHOR MILLS;** \$60,000; J. S. Spencer, (C pres.; C. W. Johnston (Charlotte) treas.; P. W. Goodrum, supt.; Yarns and Cloth; 4100 spindles; 200 looms; steam; sell direct.

**Jamestown.** A-5. S. Ry Co.

**OAKDALE COTTON MILLS;** \$50,000; W. H. (C Ragau, pres.; J. S. Ragsdale, treas., and agt.; W. G. Ragsdale, supt.; Yarns, 4s to 20s, two to ten ply and Twines; 734 ring spindles; water and steam; dye; sell di-rect; and Amon Green & Co, Balto, E. H. Hamilton & Co. and Robinson-Hughes Co., s. agts; Wm. G. Ragsdale, buyer.

**Jonesboro.** B-7. C. F. & Y. V. RR.

**EUGENIA MFG. CO.;** \$100,000 (authorized (C \$100,000); successors to Jonesboro Cotton Mills Co.; D. Clarke (Charlotte), pres.;

W. A. G. Clark (Jonesboro), treas. and gen'l mgr.; J. A. Nelson, supt.; Coarse Cotton Yarns, 4s to 16s Skein Yarn; 3200 spindles; steam; sell through agents; W. A. G. Clark, buyer.

**Kernersville.** A-5. RR. Station Derita, Son. RR.

DAVIS-CREWS KNITTING MILL, THE; L. J. Davis, pres.; E. G. Davis, treas.; T. A. Jones, supt.; Men's Half Hose; 12 knitting machines; 3 loopers; 3 ribbers; steam; sell direct.

ELMIRA HOSIERY MILLS; Ashworth & (K) Guyer. All grades of Hosiery; 20 knitting machines; steam.

GREENFIELD, J. M.; O. B. Johnson, (K) supt.; 84 needle Half Hose; 15 knitting machines; sell direct. (Buy mixed cotton yarns.)

SOUTHERN WOOLEN MILLS; J. F. Kerper; (W) Blankets and Roller Cloths; 1 set; 4 looms; s. cam; dye; sell direct; J. F. Kerper, buyer. (Buys cotton warps, usually No. 10.)

VICTOR HOSIERY MILLS; W. H. Leak & (K) Co., props.; Men's Heavy Half Hose; 12 knitting machines; steam; sell direct; W. H. Leak, buyer.

**Kimetsville.** B-6. C. F. & Y. V. RR.

M. PLEASANT MFG. CO.; \$60,000; W. H. (C) Ragan, pres.; J. S. Ragsdale, treas.; R. D. White, mgr.; 8 yd. Plaids; 2000 ring spindles; 101 looms; steam; dye; Hunter Mfg. & Com. Co. Greenboro, N. C., s. agts; R. D. White, buyer. (RR. station, Liberty, eight miles distant.)

**King's Mountain.** C-4. S. R'y Co.

BONNIE COTTON MILLS; \$90,000; J. S. (C) Mauney, pres.; W. A. Mauney, treas.; Chas. E. Neisler, supt.; Coarse and Fine Yarns; 5160 ring spindles; steam; W. M. & F. W. Sharples, Phila., s. agts; W. A. Mauney, buyer.

CORA COTTON MILLS, THE; \$100,000; F. (C) Dilling, pres.; O. G. Falls, treas.; J. M. Williams, supt.; Coarse Yarns, Skeins and Warps, Nos. 6s to 16s; 5000 spindles; W. M. & F. W. Sharples, Phila., s. agts.

CROWDER MOUNTAIN COTTON MILLS; (C) \$61,000; D. M. Barker, pres.; P. S. Baker, treas. sec. and mgr.; W. W. Shealy, supt.; Brown Sheetings; 3340 ring spindles; 121 looms; steam and water; Robinson & Shackleton, N. Y., s. agts; P. S. Baker, buyer.

DILLING COTTON MILLS; \$188,000; F. (C) Dilling, pres.; Chas. A. Dilling, treas.; J. M. Williams, supt.; Sheetings; 11,336 spindles; 352 looms; steam; Robinson & Shackleton, N. Y., s. agts; F. Dilling, buyer.

ENTERPRISE MILLS; \$50,000; F. Dilling, (C) pres.; W. T. Bradford, sec., treas. and buyer; J. M. Williams, supt.; Brown Sheetings; 5376 spindles; 130 looms; steam; Robinson & Shackleton, N. Y., s. agts.

KING'S MOUNTAIN MFG. CO.; \$100,000; (C) (\$39,750 paid in); W. A. Mauney, pres.; S. A. Mauney, treas.; G. E. Neisler, supt.; S. J. Mauney, gen'l mgr.; Brown Sheetings and Yarns; 5000 ring spindles; 130 looms; steam; W. M. & F. W. Sharples, Phila.; O. M. Harper, N. Y., s. agts.; J. S. Mauney, buyer.

LELU MFG. CO.; \$100,000; P. S. Baker, (C) pres.; D. M. Baker, treas.; W. W. Shealy, supt.; Coarse Hosiery and Weaving Yarns; 5000 ring spindles; steam; sell direct and through agents.

**Kinston.** B-9. A. C. L. RR.; A. & N. C. RR.

KINSTON COTTON MILLS; \$80,000; W. C. (C) Fields, pres.; J. F. Taylor, treas. and mgr.; F. C. Dunn, sec.; J. W. Black, supt.; High Grade Knitting Yarns for Hosiery and Underwear, Nos. 8s to 30s; 10,000 ring spindles; steam; sell direct and Jas. E. Mitchell & Co, Phila., s. agts; J. F. Taylor, buyer.

ORION KNITTING MILLS; \$40,000; Dr. H. (K) Tull, pres.; J. F. Taylor, treas. agt. supt. and buyer; Cotton Hose and Half Hose; 115 knitting machines; steam; dye; sell direct.

**Laurel.** A-8. S. A. L. RR.

JONES, J. F., Laurel Mills; E. C. Jones, (C) agt.; J. A. Andrews, supt.; Cotton Yarns, Knitting Cotton and Carpet Warps; 650 spindles; water; sell direct; J. F. Jones, buyer.

**Laurel Bluff.** A-5. C. F. & Y. V. RR.

THOMPSON, A. J.; Edw. C. Thompson, (C) supt.; A. J. Thompson, buyer; Yarn and Warps, 8s to 20s, Single and Double; 2500 spindles; water; Jas. E. Mitchell & Co, Phila., s. agts. (RR. station, Mt. Airy, two miles distant.)

**Laurel Hill.** C-6. S. A. L. RR.

IDA YARN MILL; \$60,000; M. Morgan, (C) pres.; W. H. Morrison, treas. supt. and buyer; Yarns; 4400 ring spindles; steam and water; Eddy & Street and Schell, Taylor & Longstreth, s. agts.

RICHMOND COTTON FACTORY; Mark Mor. (C) gen. pres.; M. L. Morgan, treas.; Yarn; 2500 spindles; Chas. J. Webb & Co, Phila., s. agts.

SPRINGFIELD COTTON MILL; Mark Mor. (C) gen. pres.; W. H. Morrison, treas. and supt.; Knitting and Weaving Yarns, Combs, Tubes and Skein; 3500 spindles; water and steam; Catlin & Co., Boston; Eddy & Street, Prov.; Schell, Taylor & Longstreth, Phila., s. agts. W. H. Morrison, buyer. (Four miles from Laurel Hill.)

**Laurelburg.** C-6. Sea Air Line.

DICKSON COTTON MILL; \$150,000; J. P. (C) McRae, pres.; J. M. Covington, sec. and treas.; J. P. McRae, agt.; B. L. Stewart, supt.; Yarns and Warps, 8s to 16s at present, single, 2, 3 and 4 ply, wet or dry twist, Skein Yarn and Chain Warps; 5000 ring spindles; steam; sell through agents; J. P. McRae, buyer.

SCOTLAND COTTON MILLS; \$100,000; J. F. (C) McNair, pres. and treas.; L. A. Tatum, vice-pres.; S. V. Upehurch, supt.; Fine Hosiery Yarns; 10,000 ring spindles; steam; sell through agents; L. A. Tatum, buyer.

**Lawndale.** B-4. (RR. station Shelby.) C. C. RR.

CLEVELAND COTTON MILLS; \$100,000; H. (C) F. Schenck, pres.; T. J. Ramsaur, treas.; J. F. Schenck, supt.; Carpet Warps, Twine, Wicks, Clothes Lines; 5200 ring spindles; water and steam; dye and bleach; Jas. E. Reynolds & Co., N. Y., s. agts; H. F. and J. F. Schenck, buyers. (Buy 4/8 2 warp.)

**Leaksville.** A-6. See *Spray*.

**Lenoir.** A-4. C. & N. RR.

LENOIR COTTON MILL; \$75,000; M. M. (C) Courtney, pres.; G. W. F. Harper, vice-pres.; J. D. Moore, treas.; J. C. White, supt.; Fine Yarns; 6000 ring spindles; Chas. J. Webb & Co., s. agts.

**Lexington.** B-5. S. R'y Co.

NOKOMIS COTTON MILLS; \$100,000; C. A. (C) Hunt, pres. and supt.; D. H. Hinkle, treas.; Print Cloths; 5500 ring spindles; 170 looms; steam; H. J. Farber Dreyfus & Co, s. agts; C. A. Hunt, buyer. (Capacity of mill is 12,000 spindles and 350 looms; only above installed at present.)

WENONAH COTTON MILLS; W. E. Holt, (C) prop.; Plaids, Sheetings and Yarns; 11,000 spindles 432 looms; steam; dye; Cone Export & Com. Co. and H. J. Farber Dreyfus & Co, N. Y., s. agts.

**Lileston.** A-4. RR. Station, Taylorsville, S. R'y.

MOORE COTTON MILLS; \$80,000; J. H. (C) Moore, prop.; 48x48 3 yd. and 48x52 4 yd. sheeting; 2000 ring spindles; 96 looms;

steam and water; sell direct; J. H. Moore, buyer.

**Lincolnton.** B-4. S. A. L. RR.; C. & L. RR.

DANIEL MFG. CO; \$160,000; Daniel E. (C) Rhyne, pres; Edgar Love, sec. and treas; R. W. Hunter, supt; Combed Yarns; 8000 ring spindles; steam; sell direct; Edgar Love, buyer.

DELLMA COTTON & WOOLEN MILLS; (C & W) J. L. Kistler & Co.; Cotton and Woolen Yarns; 2000 spindles; steam; 1 set; 4 looms; Wm. D'Olier & Co., Boston and Phila., s. agts.

ELM GROVE COTTON MILLS; \$100,000; S. (C) Smith, pres.; R. S. Reinhardt, treas. and mgr.; No. 20 to 40, 2 ply and 10 to 20s. Hosiery, High Grade Yarns; 6000 ring spindles; steam; sell direct and Buckingham, Paulson & Co., s. agts.; R. S. Reinhardt, buyer.

INDIAN CREEK MILLS; \$30,000; W. A. (C) Rudisill, pres; S. A. Mauney, sec. and treas; C. E. Niesler, supt; Warps and Skein Yarns; 2080 ring spindles; water; W. M. and F. W. Sharples, Phila., s. agts.

LABORATORY COTTON MILLS; D. E. Rhyne, (C) prop.; 40/2 and 50/2 Ply Skein Warps and Tube Yarns; 7500 spindles; water; Chas. J. Webb & Co. and Buckingham, Paulson & Co., N. Y., s. agts.

LINCOLN COTTON MILLS; \$85,000 (Inc.); (C) J. A. Abernathy, pres. and treas; Yarns, 40 2 to 60 2, Skein and Warps; 7000 ring spindles; steam and water; sell direct.

LONG SHOALS COTTON MILLS. See Long (C) Shoals.

RUDISILL MFG. CO., JOHN; \$20,000 (to be (C) increased to not over \$75,000); John Rudisill, pres.; E. A. Rudisill, vice-pres.; J. M. Roberts, sec. and treas; Cotton Goods, Warps and Yards, 22 to 30s; 1500 spindles; water.

**Littleton.** A-S. Sea. Air Line.

LITTLETON HOSIERY MILLS; L. Vinson, (K) treas.; Men's and Ladies' Fine Grade Hosiery, Plain Drop Stitch and Lace; 40 knitting machines; steam.

**Long Island.** B-4. (RR. station, Plotts.) W. N. C. RR.

LONG ISLAND COTTON MILLS; (office at (C) Statesville); \$50,000; G. E. French, pres.; Geo. H. Brown, treas.; Osborne Brown, supt. and buyer; Yarns, 16s to 20s, single and 2 ply; 3000 ring spindles; water; Jas. F. White & Co., N. Y., s. agts.; Osborne Brown, buyer.

**Long Shoals.** B-4. (RR. station, Lincolnton.)

LONG SHOALS COTTON MILLS; \$99,000; (C) J. S. Mauney, pres; W. A. Mauney, treas; J. B. Moore, supt; Yarns in Skein and Warp; 7280 ring spindles; water; W. M. & F. W. Sharples, Phila., s. agts.; W. A. Mauney, buyer.

**Lowell.** B-4. S. R'y Co.

LOWELL COTTON MILLS; \$100,000; H. M. (C) McAden, pres.; J. C. Rankin, vice-pres. and supt.; S. M. Robinson, sec. and treas.; Skeins and Warps, 24s to 32s. Two PLY; 5120 spindles; steam; C. J. Webb & Co., Phila., s. agts.; J. C. Rankin, buyer.

MCADEN MILLS; See *McAdenville*.

SPENCER MOUNTAIN MILLS; \$69,500; J. (C) C. Rankin, pres. and supt. J. L. Lineberger, treas; J. W. Moore, supt; 16s to 26s Cotton Yarns, single and ply; 4368 spindles; water; sell direct and through agts.

**Lumberton.** C-7. Sea. Air Line.

LUMBERTON COTTON MILLS; \$75,000; R. (C) D. Caldwell, pres; H. B. Jennings, treas; Hosiery Yarns, 20s to 32s; 5000 ring spindles; steam.

**Lynn.** C-3. RR. station, Tryon.

TRYON HOSIERY CO.; \$50,000; Frank S. (K) Wilcox, pres. and treas; W. K. Willard,

supt.; Fine Seamless Hosiery, Men's, Ladies' and Children's; 100 knitting machines; water and steam; dye; sell direct; F. S. Wilcox, buyer.

**Maiden.** B-4. C. & L. RR.

MAIDEN COTTON MILLS; \$44,000; H. F. (C) Carpenter, pres.; L. A. Carpenter, treas. and supt; Yarns single and two ply; 2280 spindles; steam; Buckingham, Paulson & Co., s. agts.; L. A. Carpenter, buyer.

PROVIDENCE COTTON MILLS; \$87,500; H. F. (C) Carpenter, pres.; D. M. Carpenter, treas. buyer and supt.; Yarns; 5000 mule and 5000 ring spindles; steam and water; sell through different agts.

UNION COTTON MILLS; \$123,500; D. M. (C) Carpenter, pres.; J. W. Williams, treas.; D. M. Carpenter, supt; Cotton Yarns and Warps; 9000 spindles; 1600 twistlers; steam; Buckingham, Paulson & Co., s. agts.

**Manchester.** C-7. C. F. & Y. V. RR.

MURCHISON COTTON MILLS; Williams (C) and Fairley, props; Warps, Yarns; 2800 spindles; steam and water; dye; sell direct.

**Mariposa.** B-4 S. A. L. RR.

MORRISON, J. G.; W. S. McCloud, supt; (C) Skein and Warps; 20s to 30s, mostly 2 ply; 2500 ring spindles; steam and water; sell direct. (RR. station, Stanley Creek.)

**Maxton.** C-6. S. A. L. RR.; C. F. & Y. V. RR.

MAXTON COTTON MILLS; Single and (C) Twisted Cotton Yarns; 1536 spindles; steam; sell direct. (Plant purchased by H. C. McNair.)

**Mayodan.** (Rockingham Co.) A-6. N. & F. RR.

AVALON MILLS; \$150,000; F. H. Fries, (C) pres; W. C. Ruffin, treas. and supt; Combed Hosiery and Underwear Yarns, 6s to 30s; 13,000 mule spindles; water; dye; H. M. Daniel, Phila., s. agt.

MAYO MILLS, THE; \$300,000; F. H. Fries, (C) pres.; Wm. C. Ruffin, treas. and supt.; Hosiery and Underwear Yarns, 6s to 30s; 31,816 mule spindles; water; sell direct; 519 Bourse, Phila., H. M. Daniel in charge; W. C. Ruffin, buyer.

**McAdenville.** B-4. S. R'y Co.

MCADEN MILLS; \$500,000; J. H. McAden, (C) pres.; Robt. R. Ray, treas. and buyer; Plaids, Denims, Etc.; 15,000 spindles; 350 looms; water; dye; Catlin & Co., Boston, and Cone Exp. & Com. Co., N. Y., s. agts. (RR. station, Lowell, one and half miles distant.)

**Milledgeville.** B-5. S. R'y Co.

ELDORADO COTTON MILLS; \$100,000; W. (C) A. Smith, pres; W. H. White, treas; T. C. Ingram, supt; Coarse Cotton Yarns; 5,000 ring spindles; water; sell direct; T. C. Ingram, buyer. (RR. Station, New London, four miles; P. O. Address, Ansonville.)

**Monbo.** B-4. S. R'y Co.

MONBO MFG. CO., \$50,000; W. D. Turner, (C) pres; C. L. Turner, treas. and mgr; Rome Saunders, supt; C. L. Turner, buyer; Skein and Cone Knitting Yarn; 2832 spindles; water; Jas. E. Mitchell & Co., Phila., s. agts. (RR. station, Catawba, eight miles away.)

**Monroe.** C-5. S. A. L. RR.

MONROE COTTON MILLS; \$135,000; O. P. (C) Heath, pres.; W. C. Heath, treas.; J. F. Cunningham, supt; Warps, Skeins and Hosiery Yarns on Cones; 8320 spindles; steam; Catlin Co., & N. Y. and Boston, s. agts. W. C. Heath, buyer.

**Mooreville.** B-4. S. R'y Co.

MOOREVILLE COTTON MILLS; \$150,000; J. E. (C) Sherrill, pres.; S. C. Rankin, sec. and treas.; P. S. Boyd, supt.; Sheetings, Single



- and 2-ply Yarn, 26 to 40; 3,740 ring spindles; 181 looms; steam; Catlin & Co.; Buckingham, Paulson & Co. and W. M. and F. W. Sharples, s. agts.; P. S. Boyd, buyer. (Mill No. 2; 5,000 spindles and 2,500 twister spindles.)
- Morganton.** B-4. S. R'y Co.
- ALPINE COTTON MILLS; \$100,000; W. A. (C) Erwin, pres; Thos. P. Moore, treas. and supt; Warps; 11,000 ring spindles; steam; sell direct; Thos. P. Moore, buyer. No. 2 mill erected.
- Mt. Airy.** A-5. C. F. & Y. V. RR.
- ALPINE WOOLEN MILLS; M. J. Haw. (W) kins, prop. (P. O. address, Hazel); W. S. Allred, agt, supt. and buyer; Jeans, Cassimeres, Blankets and Yarns; 1 set; 13 looms; steam and water; dye; sell direct. (Buy cotton warps, Nos. 10 and 12.)
- HAZELHURST COTTON MILL; J. Q. Gant, (C) treas; Wm. H. Sumner, supt; Cotton Yarns, Warps, Etc; 1000 spindles; sell direct; J. Q. Gant, buyer.
- HAMBURG COTTON MILLS; D. W. C. Ben- (C) low (Greensboro, N. C.); Cotton Yarns and Sheetings; 1600 ring spindles; 40 looms; water.
- Mt. Holly.** B-4. S. A. L. RR.
- ALBION CO.; A. P. Rhyne, prop; T. (C) Brinkley, supt. and buyer; 4s to 16s, single and ply Skeins and Warps; 2,500 ring spindles; steam; sell direct and through commission houses.
- MT. HOLLY COTTON MILLS; A. P. Rhyne (C) & Co.; J. A. Castner, supt. and buyer; 20/2 Warps; 1936 ring spindles; water and steam; sell through agts.
- NIMS MFG. Co.; \$37,500; M. R. Dewstoe, (C) pres.; C. E. Hutchison, treas. and buyer; A. M. Kale, supt.; Cotton Yarns, 14s to 20s, 2 to 6 ply; 2888 spindles; water; sell direct, and Buckingham, Paulson & Co, N. Y., s. agts.
- TUCKASEEGE MFG. Co.; \$120,000; A. P. (C) Rhyne, pres.; A. C. Lineberger, treas., agt. and supt.; A. C. Lineberger, buyer; Warps and Skein Yarn in Single and Ply; 5,000 ring and 1,980 twister spindles; water; sell direct and Jas. E. Mitchell & Co., Phila. and Boston, s. agts.
- Mountain Island.** B-4. S. A. L. RR.
- MOUNTAIN ISLAND MILLS; Wm. T. Jordan, (C) mgr; Plaids, Sheetings, Shirtings, Osunaburgs, Cotton Towels, Yarns, Netting and Seine Twines of All Kinds; 6200 spindles; 104 looms; water; dye; Jas. F. White & Co. and E. H. Hamilton Co, s. agts. (RR. station, Mt. Holly.)
- Mt. Pleasant.** B-5. (RR. Station, Concord.) S. Ry. Co.
- KINDLEY, W. R., COTTON MILLS; \$50,000; (C) J. L. Peck, pres; W. R. Kindley, treas.; A. N. James, agt; Yarns from 26/2 to 40/2 and 3 ply; 3664 ring spindles; steam; Wm. D'Oliver & Co. and Buckingham, Paulson & Co., s. agts.; Jas. L. Peck, buyer.
- TUSCARORA COTTON MILL; J. W. Cannon, (C) pres.; Paul Barringer, sec. and treas.; A. N. James, mgr; Hosiery Yarns, 20s to 30s; 2880 spindles; steam; C. J. Webb & Co., Phila., s. agts.; Paul Barringer, buyer.
- Newbern.** C-9. W. N. & N. RR.; A. & N. C. RR.
- SOUTHERN HOSIERY MILLS; (formerly - K) Clermont Mills); Ladies', Misses' and Men's Hosiery; 108 knitting and 20 sewing machines; 79 ribbers; steam; dye; Bacon & Co. s. agts, also sell direct. (Buy white coned yarn.)
- PEMBROKE MFG. Co. *Out of business.*
- New London.** B-5. S. RR.
- TUCKER & CARTER ROPE CO. \$75,000; W. (C) A. Tucker, pres; John G. Healy, vice-pres; H. Evelyn Pierrepont, Jr, treas; A. I. Napier, supt; Window and Car Cords, Clothes Lines and Braids; 225 braiders; steam; dye; sell direct; A. I. Napier, buyer. (Buy 8/3 carpet warps, also 12/3, some on tubes-6 x4" beam.) (Office at New York City.)
- Newton.** B-4. S. R'y Co.; C. & L. RR.
- CATAWBA COTTON MILLS; \$50,000; J. P. (C) Yount, pres. and treas; R. B. Knox, supt; Yarns, 30s to 50s, Skeins, Chains and Warps; 3000 ring spindles; steam; Chas. J. Webb & Co, Buckingham, Paulson & Co. and J. Spencer Turner Co., s. agts; J. P. Yount, buyer.
- NEWTON COTTON MILLS, THE; \$60,000; B. (C) D. Heath, pres.; J. C. Smith, sec. and treas.; W. G. Bacon, supt; Yarns and Warps single and two ply; 8500 ring spindles; steam; sell through agents; J. C. Smith, buyer.
- NEWTON HOSIERY MILLS; D. J. Carpen- (K) ter; J. G. Berry, supt; Men's, Ladies' and Misses' Hosiery; 150 knitting machines; steam; dye; sell direct; D. J. Carpenter, buyer.
- North Brook.** B-4. C. & N. RR. Seaboard Air Line.
- JENKS, T. P.; North Brook Woolen (W) Mills; Knitting and Weaving Yarns; 1 set; 180 spindles; steam. (P. O. address, Hall Cross Roads.)
- Norwood.** B-5. S. RR.
- NORWOOD MFG. Co.; \$200,000 (paid in, (C) \$90,000); D. B. Coltrane, pres; J. A. Tyson, sec. and treas.; J. F. Shinn, supt; Fine Yarns; 8100 ring spindles; steam; sell through agents; president and treasurer, buyers.
- Oxford.** A-7. Sou. Ry.
- OXFORD COTTON MILL CO; \$125,000; J. (C) G. Hall, pres; J. C. Cooper, treas.; E. W. Worth, agt. and supt.; Yarns, Single and Ply, 8s to 15s; 6120 ring spindles; steam; E. W. Worth, buyer.
- Patterson.** A-4. C. & N. RR.; C. & L. RR.
- GWYN-HARPER MFG. Co.; \$70,000; S. (C) & W F. Harper, pres.; Jas. Harper, treas.; Cotton Yarns and Plaids and Woolen Jeans, Cassimeres and Blankets; 2000 spindles; 40 cotton and 15 woolen looms; 2 sets; water and steam; dye; Fred'k Victor & Achelis, N. Y., s. agts.; S. F. Harper, buyer. (RR. station, Lenoir.)
- Plateau.** B-4.
- CATAWBA WOOLEN MILLS; \$6000; J. A. (W) Martin, pres.; U. W. Whitener, supt; Woolen Yarns; 2 sets; water; sell direct; U. W. Whitener, buyer. (Office at Hickory.)
- Raleigh.** B-7. S. A. L. RR.; S. R'y Co.
- CARALEIGH MILLS CO.; \$185,000; A. S. (C) Thompson, pres.; F. O. Moring, treas.; H. C. Butler, supt.; F. O. Moring, buyer; Dress Ginghams; 10,400 ring spindles; 400 looms; steam; dye; Fred'k Victor & Achelis, N.Y., s. agts.
- MELROSE KNITTING MILLS; \$25,000; V. (K) B. Moore, pres. and treas; J. S. Wynne, vice-pres; J. W. Harden, Jr, sec; F. W. Kohler, mgr. and supt; Cotton Ribbed Underwear; 15 knitting machines; 2 winders; 80 spindles; 20 sewing machines; steam; Critten, Clift & Co, N. Y., s. agts; V. B. Moore, buyer. (Buy yarns, 6s to 24s, colored and white.)
- NEUSE RIVER MILLS; \$125,000; C. G. Latta, (C) pres, treas. and buyer; H. W. Vass, sec; John A. Drew, supt; Brown Sheetings; 5,000 ring spindles; 150 looms; water; J. Spencer Turner Co., N. Y., s. agts.; C. G. Latta, buyer.
- PILOT COTTON MILLS; Jas. N. & W. H. (C) Williamson; W. P. Hornbuckle, supt.; Colored Cotton Goods; 5600 ring spindles; 205 looms; steam; dye and finish; Cone

- Export & Com. Co., N. Y. and Greensboro, N. C., s. agts; W. H. Williamson, buyer.
- RALEIGH COTTON MILLS;** \$157,000; C. G. (C) Latta, pres.; J. S. Wynn, treas.; H. B. Gresson, supt.; treasurer, buyer; Mule Spin. Hosiery Yarns; 14,496 spindles; steam; Jas. E. Mitchell & Co., Phila., s. agts.
- RALEIGH HOSIERY CO.;** \$25,000; W. W. (K) Ashe, pres.; S. A. Ashe, Jr, treas.; Chas. H. Pate, supt.; Hosiery; 125 knitting machines; steam; dye; sell direct and through agts.
- Ramseur.** B-6. C. F. & Y. V. RR.
- COLUMBIA MFG. CO.;** \$185,000; J. S. Spencer, pres.; W. H. Watkins, treas. and agt.; E. C. Watkins, supt. and buyer; 4/4 yd. Sheetings; 11,072 spindles; 350 looms; steam and water; Hunter Mfg. and Com. Co., N. Y. and Greensboro, s. agts.; W. H. Watkins and E. C. Watkins, buyers.
- Randleman.** B-6. S. RY Co.
- WORTH MFG. CO.** See Worthville, N. C.
- NAOMI FALLS MFG. CO.;** \$108,550; S. G. (C) Newlin, pres.; S. Bryant, treas.; H. O. Barker supt.; S. Bryant, buyer; Colored Cotton Goods, Seamless Grain and Salt Bags; 6000 spindles; 335 looms; steam and water; dye; sell direct and E. H. Hamilton & Co, N. Y., s. agts.
- PLAIDVILLE MFG. CO.;** \$50,000; S. G. New. (C) Lin, sec. and treas.; C. C. Randleman, supt; Plaids, Cottonades, Cheviots, Denims, Domets; 198 looms; steam; E. H. Hamilton & Co, N. Y., s. agts.
- RANDLEMAN HOSIERY MILLS;** \$15,000; (K) S. G. Newlin, treas.; A. N. Bulla, mgr; Half Hose in Mixtures and Black; also Misses' and Children's Ribbed Goods (in Immedial Blacks); 51 knitting machines; steam; dye; sell direct. *Burred Oct., '01. Rebuilt.*
- RANDLEMAN MFG. CO.;** \$150,000; G. Rosen- (C) thal, pres.; S. G. Newlin, treas.; C. C. Randleman, supt; Checks, Stripes and Plaids; 7000 spindles; 350 looms; steam and water; dye; E. H. Hamilton & Co, N. Y., s. agts.
- Reidsville.** A-6. S. RY Co.
- EDNA COTTON MILLS;** \$135,500; W. S. (C) Forbes, pres.; J. B. Pipkin, treas. and agt.; J. W. Manly, supt; Twills, 43" 48/60, 4/30 and 39" 64/48 6/00; 25,000 ring spindles; 552 looms; steam; Carey, Bayne & Smith Co, s. agts; J. B. Pipkin, buyer.
- Roanoke Rapids.** A-8.
- PATTERSON TEXTILE CO.;** Gustavus Mill. (S) hiser, pres.; S. F. Patterson, treas.; J. V. Thomason, supt; Silk Dress Goods; 250 looms; electricity; Wm. Iselin & Co, s. agts.
- ROANOKE MILLS CO.;** \$200,000; W. S. Par- (C) kor, pres.; S. F. Patterson, treas.; J. M. Jackson, sec; W. D. Jones, supt; S. F. Patterson, buyer; Colored Fancy Goods, Towels and Yarns; 14,336 ring spindles; 560 looms; water power; dye; James W. Cooke & Co, Phila.; A. D. Smith, N. Y., and R. A. Blythe, s. agts.
- ROANOKE MILLS CO. (Mill No. 2);** Men's, (K) Women's and Children's Underwear, 5-48" D. & F. sets; 24 knitting machines; water; dye.
- ROSEMARY MFG. CO.;** Gustavus Millhiser, (C) pres. and agt.; S. F. Patterson, treas.; Jno. L. Patterson, mgr.; Fancy Cotton Goods; 12,000 spindles; 400 looms; elec- tricity.
- Rockingham.** C-6. S. A. L. RR.
- GREAT FALLS MFG. CO.;** \$100,000; D. L. (C) Gore pres.; Claude Gore, sec., treas. and supt.; Sheetings and Drills; 424 ring spindles; 145 looms; steam and water; Joshua L. Baily & Co., Phila., s. agts.
- LEAK, WALL & McRAE;** Midway Mills; (C) \$50,000; J. P. Leak, pres. and treas.; F. T. Briggs, supt.; Chain Warps, Carpet Yarns; 6000 ring spindles; water; Cotton Mfgs. Com. Co., N. Y., s. agts.
- LEDBETTER MFG. CO.;** South Union Mills; (C) \$25,000; T. B. Ledbetter, pres. and treas.; J. S. Ledbetter, buyer; Carpet Yarns, 14/2 Skeins; 2680 ring spindles; water and steam.
- LEE DEE MFG. CO.;** \$187,000; W. C. Leak, (C) pres. and treas.; Wm. Entwistle, supt.; Plaid Domets and Hickory Shirting, etc; 12,784 spindles; 602 looms; steam and water; dye; Cone Export Com. Co., Greensboro, s. agts.
- ROBERDEL MFG. CO.;** \$125,000; T. C. (C) Leak, Jr, pres. and treas; S. S. Steele, supt; Plaids; 6384 ring spindles; 24 sets; 300 looms; water and steam; dye; Cone Export & Com. Co, Greensboro, s. agts. (To build new mill, 7500 spindles and 350 looms.)
- STEELE'S MILLS;** \$225,000 (paid in); Rob- (C) ert L. Steele, pres. and treas.; R. A. Johnson, sec; W. B. Cole, supt; Print Cloths; 21,304 spindles; 600 looms; steam and water; R. L. Steele, buyer; Robinson & Shackelton, N. Y., s. agts.
- TEXTILE MFG. CO.;** \$25,000; W. L. Parsons, (C) pres; H. S. Ledbetter, sec. and treas; F. T. Briggs, supt. and buyer; Weaving, Back Bands and Girthing; 12 looms; steam; dye; Hy. Keedel & Co, Balto, Md, s. agts.
- Rocky Mount.** B-8. A. C. L. RR.
- ROCKY MOUNT MILLS;** \$472,500; R. H. (C) Ricks, pres.; Thos. H. Battle, treas; F. C. Ferguson, supt.; Yarns and Warps; 25,000 spindles; steam and water; sell through agents; Thos. H. Battle, buyer.
- Roxboro.** A-7. N. & W. RR.
- ROXBORO COTTON MILLS;** \$100,000; J. A. (C) Long, pres; R. E. Long, sec, treas. and agt; J. W. Allgood, supt; Yarns, 20s only, viz., 20/2 skein and warp, 20/1 skein and warp; 5000 ring spindles; steam; Wm. D'Offer & Co., Phila., agts.; R. E. Long, buyer.
- Rutherfordton.** B-3. S. A. L. RR.; O. R. & C. RR.
- LEVI COTTON MILLS CO.;** \$200,000; Myer (C) Levi, pres; W. E. Flack, treas; H. A. Bell, supt; 20s to 40s Yarns and Warps; 6,240 ring spindles; steam; sell direct and P. Burnstone, 30 Bond St., N. Y. s. agt.; M. Levi, buyer.
- Salem.** A-5. S. Ry. Co.; N. & W. RR. See Winston-Salem.
- Salisbury.** B-5. S. Ry. Co.
- KESLER MFG. CO.;** \$125,000; J. W. Cannon, (C) (Concord), pres; F. L. Robbins, treas; Yarns, 18s to 30s, single; 11,232 ring spindles; steam; sell direct and through agents; F. L. Robbins, buyer.
- LITTMAN, I.;** Max Moses, supt; Twines, (C) Plow Lines, Braided Sash Cord, Bell Cord and Clothes Lines; 1200 spindles; 60 braiders; steam; sell direct.
- SALISBURY COTTON MILLS;** \$250,000; F. J. (C) Murdoch, pres.; O. D. Davis, treas.; J. M. Knox, agt.; F. M. Ward, supt.; Gingham, Cheviots, Tickings; 20,000 ring spindles; 592 looms; steam; dye; Cone Export & Com. Co., N. Y., s. agts; J. M. Knox, buyer. Also branch mill at Woodleaf.
- SALISBURY HOSIERY MILLS;** \$80 0; S. H. (K) Wiley, pres; Geo. F. Seyffert, treas. and supt; Cotton Hosiery; 640 spindles; 45 knitting machines; steam; dye; sell direct; Geo. F. Seyffert, buyer.
- VANCE COTTON MILLS;** \$100,000; Dr. J. A. (C) Caldwell, pres; W. C. Blackmer, treas; E. B. Neave, mgr; Yarns, for Warps and Filling, 18s/1 to 24s/1; 10,000 ring spindles; steam; sell direct; E. B. Neave, buyer.

**Sanford.** B-7. C. F. & Y. V, and Sea Air Line.  
**SANFORD COTTON MILLS;** \$125,000; Wm. (C) H. Watkins, pres.; T. L. Chisholm, sec. and treas.; W. T. Hurly, supt.; 4 yd. Sheetings; 9000 ring spindles; 300 looms; steam; T. L. Chisholm, buyer.

**Saxapahaw.** B-6. S. Ry. Co.  
**WHITE, WILLIAMSON & CO.;** W. H. Gil- (C) liam, supt.; Cloths and Yarns; 5000 spindles; 100 looms; water; dye; Farris-Stafford Co., s. agts.; cloth; sell yarns direct. (RR. station, Graham.)

**Scotland Neck.** A-9. A. C. L. RR.  
**CRESCENT HOSIERY CO., THE;** (formerly (K) the Lockland Mills); \$10,000; George T. Andrews, pres.; L. M. Pittman, vice-pres.; Chas. L. McDowell, treas.; Robert E. Shew- (C) rt, supt.; Ladies' and Children's Ribbed Hosiery; 75 knitting machines; steam; sell direct; Chas. L. McDowell, buyer.

**SCOTLAND NECK COTTON MILLS;** \$48,000; (K) A. McDowell, pres.; J. S. Bowers, treas.; W. H. McDowell, supt.; Underwear 7 1/2 Garments and All Styles of Misses' Hose; 140 knitting and sewing machines; steam; sell direct; A. McDowell and J. S. Bowers, buyers.

**SHIELDS KNITTING MILL;** E. Shields; (K) Men's Half Hose; 25 knitting machines; steam; Domestic Hosiery Co, s. agts.

**Shelby.** B-4. S. A. L. RR.; O. R. & C. RR.  
**BELMONT COTTON MILLS;** \$60,000; A. C. (C) Miller, pres., treas. and buyer; B. L. Stewart, supt.; Single and Twisted Cotton Yarns, 10s to 20s; 4500 spindles; steam Jas. E. Mitchell Co, Phila, s. agts.

**BURTON MILLS** (formerly Lauraglen (C) Mills); R. B. Miller, gen'l mgr.; Cotton and Carpet Yarns and Ball Twine; 2,800 spindles; water; Jas. E. Mitchell & Co., Phila. and E. H. Hamilton & Co., N. Y., s. agts.; R. B. Miller, buyer.

**LURA KNITTING MILL;** \$10,000; Orlando (K) Elum, sec. and treas.; C. W. Lattimore, mgr.; Ladies' Hose and Men's Half Hose; (100 doz. per day.) dye. *Burned Nov., '01.*

**MARY-ETTA MILLS.** *Will not build and project reported abandoned.*

**SHELBY COTTON MILLS;** \$150,000; H. D. (C) Wilson, pres. J. H. Hull, sec. and treas.; M. M. Manney, supt. and mgr; Fine Yarns, 40s, and Sheetings; 7488 ring spindles; 225 looms; steam; Dixon & Hanna, N. Y., and W. M. & F. W. Sharples, s. agts.; J. H. Hull, buyer.

**WILLIAMS, J. F.;** Mr. Prim, supt; Ho- (K) siery; 15 knitting machines; 5 ribbers; 3 loopers.

**Siler City.** B-6. C. F. & Y. V. RR.  
**HADLEY, PEOPLE'S MFG. CO.;** \$30,000; (C) J. A. Hadley, pres.; J. C. Gregson, sec. and treas.; H. C. Robbins, supt; Slack Reeled Yarns, 8s to 16s, 2, 3 and 4 ply; 2,500 ring spindles; steam; sell through Phila. agts.; J. C. Gregson, buyer.

**Smithfield.** B-8. A. C. Line.  
**SMITHFIELD COTTON MILLS;** \$75,000; A. K. (C) Smith, pres.; S. S. Holt, treas.; F. A. Cunnock, mgr. and supt; Yarns, 20s to 26s; 5000 ring spindles; steam; dye; sell direct and through agts.

**Snow Camp.** B-6. B. F. & Y. V. RR.  
**DIXON MFG. CO.;** \$7200; Eula Dixon, (W) pres.; T. F. McVey, treas., agt. and buyer; Jeans, Flannels, Yarns, Blankets; 2 sets; 17 looms; steam and water; dye; sell direct. (RR. station, Liberty, eight miles away.)

**Spray.** A-6. D. & W. RR.  
**AMERICAN WAREHOUSE CO.;** \$200,000; (F) E. L. Fuller, pres.; F. M. Elliott, Jr., sec., treas. and buyer; Finishing Cotton Piece Goods; steam.

**LEAKSVILLE COTTON MILLS;** \$30,000; B. (C) F. Mebane, pres.; W. R. Walker, treas.; J. M. Lewis, supt; W. R. Walker, buyer; Gingham, Colored Goods, Etc.; 3100 ring spindles; 635 looms; water; dye; Fredk Victor & Achelis, N. Y., s. agts. (Buy yarn, 15s, 16s and 22s.)

**LEAKSVILLE WOOLEN MILL;** \$47,000; (W) Hiram Ford, pres.; M. J. Tyler, supt.; Blankets, Piece Goods, Yarns, etc.; 3 sets; 16 broad looms; 14 narrow looms; water; dye; sell direct.

**LILY MILLS;** \$30,000; (privilege of \$1,000. (C) 000); B. Frank Mebane, pres.; J. S. McAlister, treas; W. E. Fearington, supt; Colored Cotton Goods; 2436 ring spindles; 382 looms; steam; dye.

**NANTUCKET MILLS;** \$225,000; B. Frank (C) Mebane, pres.; J. S. McAlister treas; N. T. Brown, supt; Colored Cottons; 6420 ring spindles; 787 looms; steam and water; dye; Fredk Victor & Achelis, N. Y., s. agts; J. S. McAlister, buyer.

**SPRAY COTTON MILLS;** \$153,000; Geo. A. (C) Mebane, pres; W. R. Walker, treas; J. S. Patterson, agt.; D. M. La-hley, supt.; Yarns; 24,000 spindles; water and steam; sell direct; J. S. Patterson, buyer.

**Staley.** B-6. C. F. & Y. V. RR.—(Colyridge.)  
**ROBERTSON MFG. CO.;** W. G. Robertson, (C) pres. and gen. mgr.; A. N. Robertson, sec. and treas; Yarns, 6 to 12, single and ply; 1500 ring spindles; sell through agts.

**Stanley.** B-4. S. A. L. RR.  
**MORRISON, J. G.** See Mariposa.

**STANLEY CREEK COTTON MILLS;** \$70,000; (C) A. P. Rhyne, pres.; E. L. Pegram, Jr., treas.; N. G. Manney, supt.; Yarns and Warps; 5000 ring spindles; steam; sell direct; A. P. Rhyne, buyer.

**Statesville.** B-5. S. Ry Co.  
**NOOE, R. E.** Interested in establishing a (C) Cotton Batting mill. *Proposed.*

**STATESVILLE COTTON MILLS, THE;** \$187, (C) 000; Wm. Wallace, pres.; T. D. Miller, treas. and buyer; A. B. Saunders, supt; Yarns, 8 to 30s, Skeins, Tubs, or Cones, and White Cloth, 25<sup>o</sup> to 5yd.; 10,000 ring spindles; 180 looms; steam; J. H. Lane & Co., N. Y., s. agts; T. D. Miller and A. B. Saunders, buyers.

**Stubbs.** B-4. S. A. L. RR.  
**BUFFALO MFG. CO.;** \$45,000; T. D. Latti (C) more, pres.; O. C. Dixon, treas.; W. L. Hendrick, supt; 30/2 ply Cotton Warp; 3200 spindles; water and steam; Catlin & Co. and J. E. Mitchell & Co., Phila., s. agts.; pres. and treas, buyers. (RR. station, Buffalo.)

**Sweepsonville.** A-6. S. Ry Co.  
**VIRGINIA COTTON MILLS;** \$100,000; A. L. (C) Baker, pres; E. M. Cooke, treas. sec. and supt; Suitings, Outings, etc; 72,811 ring spindles; 300 looms; water; dye; J. D. Cassard & Son, Balto, s. agts; A. L. Baker, buyer.

**Tarboro.** B-8. A. C. L. RR.  
**FOUNTAIN COTTON MILLS;** \$200,000; W. N. (C) Smith, pres.; J. A. Weddell, treas.; A. M. Vandegrift, supt; Hosiery Yarns; 10,000 spindles; steam.

**RIVERVIEW KNITTING MILLS;** John F. (K) Shackelford; Wm. Wilson, supt.; John F. Shackelford, buyer; Cotton and Merino Hosiery and Underwear; 136 knitting machines; 24 sewing machines; steam; dye; sell direct and Henry Jacobs, St. Louis, s. agt. (Buy yarns 7s to 60s.) *Burned Dec., '01; may rebuild with Stock Co.*

**RUNNYMEDE HOSIERY MILLS;** \$20,000; (K) Geo. Howard, Jr., pres; Job Cobb, treas; C. W. Jeffreys, gen'l mgr; Misses' and Children's Rib Hose; 80 knitting machines; steam; dye; C. W. Jeffreys, buyer.

- TARBORO COTTON FACTORY;** \$165,000; S. (C) S. Nash, pres.; A. M. Fairley, treas., agt., supt. and buyer; Warp Yarns and Convertible Cloths; 13,000 spindles; 200 looms; steam; sell direct. (RR. Station Tarboro.)
- Taylorsville.** A-4. S. R'y Co.
- ALSPAUGH COTTON MILL;** U. L. Alspaugh; (C) R. L. Alspaugh, supt.; Heavy Sheeting, 4/4 3yd.; 820 ring spindles; 24 looms; sell direct.
- MOORE COTTON MILLS.** See Liletoom.
- Troy.** Montgomery Co. B-6. A. & W. E. RR.
- CAPELSIE COTTON MILLS;** \$50,000; A. W. (C) E. Capel, pres; J. G. Tomlinson, treas; Yarns, 4 single and 2 ply; 2500 ring spindles; steam and water.
- SMITHERMAN COTTON MILLS;** \$50,000; S. J. (C) Smitherman, pres; A. W. E. Capel, treas; Robert L. Thomas, supt; Yarns; No. 14, single and two ply; 3228 spindles; 100 looms; steam; Wm. D'Olier & Co., Buckingham, Paulson & Co., and Thomas & Houston, Phila., s. agts; A. W. E. Capel, buyer.
- Tryon.** C-3. S. RR.
- TRYON HOSIERY CO.** See Lynn.
- Turnersburg.** B-5. S. R'y Co.
- STIMPSON & STEELE;** \$40,000; R. S. Keller, (C) supt; Yarn, single and Piled, Nos. 5 to 20; 1600 spindles; water and steam; J. E. Mitchell & Co, Phila. and Boston, s. agts; firm, buyers. (RR. station, Statesville.)
- Valdeese.** B-4. Sou. Ry.
- VALDESE HOSIERY MILLS;** John Mejer, (K) supt. and buyer; Men's and Ladies' Cotton Hosiery; 32 knitting and 2 sewing machines; steam; dye; Mann & Co., s. agts.
- WALDENSIAN HOSIERY MILL;** J. Garron, (K) pres.; A. Grill, treas.; Fr. Garron, supt.; Men's Half Hose and Misses' and Ladies' Hosiery; 25 knitting machines; steam; dye; sell direct; J. Garron, buyer. (Buy 20, 10 white and 4 mixed, 40 and 36 splicing and looping.)
- Waco.** B-4. Sea. Air Line.
- WACO KNITTING MILL;** W. A. Goode, (K) M. D., pres.; M. E. Goode, treas.; H. C. Goode, supt.; 160 needle, 36 gauge, Ladies' and Men's Hosiery; 25 knitting machines; steam; Betty & Smith, 43 Leonard St., N. Y., s. agts.; M. E. Goode, buyer. (Buy hosiery yarn, cones, nos. 10 to 15 inclusive and no. 40 splicing yarn.)
- Wadesboro.** C-6. S. A. L. RR.; A. C. L. RR.
- WADESBORO COTTON MILLS CO.;** \$100,000; (C) W. J. McLendon, pres.; Wm. L. Steele, treas.; W. J. McLendon, Jr., supt.; Yarns; 6704 spindles; steam; Wm. D'Olier & Co., Phila., s. agts.
- WADESBORO SILK CO.;** Geo. Singleton, (S) pres.; Robt. Singleton, supt.; Silk Thread; 15,000 spindles; steam; Russell Murray, N. Y., s. agts. (See Dover and Port Orant, N. J.)
- Wake Forest.** B-7. Sea. Air Line.
- ROYAL COTTON MILLS;** \$150,000; W. C. (C) Powell, pres.; R. E. Royall, vice pres. and treas.; A. H. Harwell, supt.; Skein Yarns, 20/2 and 20/1, Chain and Ball Warps; 4392 ring spindles; steam; sell direct; R. E. Royall, buyer. (Expect to add 1000 more spindles and 150 looms.)
- Washington.** B-9. Atl. Coast Line.
- HAVENS, J.;** Cotton Batting and Comb (C) forts. Proposed.
- WASHINGTON KNITTING MILL;** \$8,000; (K) Jonathan Havens, pres.; H. B. Mayo, treas.; W. L. Hosat, supt.; Misses' Hosiery; 50 knitting machines; steam; dye; sell direct; J. Havens, buyer.
- Waxhaw.** C-5. S. A. L. RR.
- RODMAN HEATH COTTON MILL;** \$93,236.04; (C) J. L. Rodman, pres. and treas; B. Nuttall, supt; 24/2 to 40/2 ply Yarns; 5,008 spindles; steam; W. M. & F. W. Sharples, s. agts; J. L. Rodman, buyer.
- Waynesville.** B-2. S. RR.
- WAYNESVILLE WOOLEN MILLS;** E. W. (W) Brown; Jeans, Blankets, Lindsays and Yarns for Knitting, single, 2 and 3 ply on Skeins; 1 set; 6 looms; water; dye; sell direct. (Buy 12s and 14s.)
- Weaverly.** B-3. S. R'y Co.
- REEMS CREEK WOOLEN MILLS CO.;** J. A. (W) Reagan, pres; J. H. Wright, treas. and agt; John Cairns, supt; Flannels, Tweeds, Yarns; 1 set; 5 looms; water; dye; sell direct.
- Weldon.** A-S. A. C. Line; S. A. Line; R. & C. R. Line.
- WELDON COTTON MFG. CO.;** \$100,000; W. T. (K) Shaw, pres; W. A. Pierce, sec. and treas; P. W. Cochrane, supt; Men's Ribbed Underwear and Mule Spun Yarns, 10 to 20s; 2016 spindles; 18 cylinders; sell direct; W. T. Shaw, buyer.
- West Durham.**
- ERWIN, THE, COTTON MILLS CO.** See Durham.
- Willardville.** A-7. N. & W. RR.
- WILLARD MFG. CO.;** \$40,000; S. A. Ashe, (C) pres; A. G. Cox, supt; Rope and Twine; 1800 spindles; steam and water; dye; sell direct; S. A. Ashe, buyer.
- Wilmington.** D-S. A. C. L. RR.; C. F. & Y. V. RR.; S. R. L. RR.; W. N. & N. RR.; W. S. C. RR.
- AMERICAN CHEMICAL & TEXTILE COLORING CO.;** H. M. Chase, mgr; Dye Raw Cotton, Warps and Skeins; capacity, 10,000 lbs. per day.
- DELGADO COTTON MILLS CO.;** \$250,000; (C) E. C. Holt, pres; R. Bellamy, vice-pres; J. W. Williamson, sec. and treas; Madras Cloths, Outings and Fancy Sheetings; 10,000 spindles; 500 looms; bleach and finish; sell through agts.
- WILLARD BAG & MFG. CO.;** Inc.; \$100,000; (J) M. S. Willard, pres.; E. Payson Willard, treas.; Burlap and Cotton Bags, and Overalls; electric power and gas; sell direct; E. P. Willard, buyer.
- WILMINGTON COTTON MILLS;** Capital (C) Stock, \$85,500; Preferred, \$86,900; Hugh MacRae, pres. and agt.; Donald MacRae, vice pres. and treas; H. H. McIlhenny, supt; Cheviots, Madras; 7436 ring spindles; 432 looms; steam; dye and finish; Joshua L. Bailly & Co., N. Y. and Phila., s. agts.; Donald MacRae and H. H. McIlhenny, buyers. (Buy 22s single and 3 ply and 44 single yarn.)
- Wilson.** B-S. A. C. L. RR.
- WILSON COTTON MILLS;** \$100,000; R. G. (C) Briggs, pres.; Jas. Lipscomb, treas.; R. O. Pickard, supt.; Warps 20/2s, 12/1s, and Skeins 12/1s; 6080 ring spindles; steam; sell direct; Jas. L. Lipscomb, buyer.
- Winston-Salem.** A-5. N. & T. and S. RR.
- ARISTA COTTON MILLS;** F. & H. (C & W) Fries; C. E. Carter, supt; Colored Shirtings, Cheviots and Chambrays; 5,280 ring spindles; 200 looms; electric; dye; A. D. Juilliard & Co., N. Y., s. agts; John W. Fries, buyer.
- FRIES, F. & H., WOOLEN MILLS;** T. E. (W) Davis, supt.; Cotton Warp Cassimeres; 3 sets; 55 looms; electricity; dye; Wm. Iselin & Co., N. Y., s. agts; John W. Fries, buyer.
- HANES, J. W.;** Shamrock Mill; J. (K) Frazier Bard, supt.; Men's, Women's and Children's Fine Gauge Cotton Hosiery;

50 knitting machines; steam; dye; sell direct. (Purchased plant of Radnor Hosiery Mills, Wayne, Pa.)

**PEOPLE'S MFG. Co.;** \$50,000; Knit Goods. (**K**)  
**SOUTH SIDE MFG. Co.;** \$125,000; H. E. (**C**)  
Fries, pres. and treas.; E. W. Lehman,  
sec.; Wm. K. Davis, supt.; Yarns and  
Madras; 10,752 spindles; 168 looms; elec-  
tric dye; R. A. Blythe, Phila. yarns, and  
A. D. Juilliard & Co., N. Y., s. agts. for  
cloth; W. K. Davis, buyer.

**TWIN CITY KNITTING MILLS;** Ladies' (**K**)  
Underwear; 24 knitting machines; electric  
power; dye. (Purchased by T. L. Vaughn.)

**VAUGHN KNITTING MILL;** L. A. Vaughn, (**K**)  
prop.; Ladies' Ribbed Underwear; sizes  
yarns, 9 to 12; R. L. Chandler, N. Y. and  
Balto., s. agts.

**WINSTON KNITTING MILLS;** \$7,500; M. D. (**K**)  
Bailey, pres. and treas.; M. D. Bailey, Jr.,  
gen'l mgr.; R. Bailey, supt.; Ladies' High  
Class Underwear; 15 knitting machines;  
electricity; Robertson & Bruhn, s. agts.;  
M. D. Bailey, Jr., buyer. (Buy yarn, 10s  
to 14s.)

**Winton. A-9. S. & R. RR.**

**WINTON KNITTING MILLS;** \$5,000; A. I. (**K**)  
Parker, pres.; S. S. Daniel, treas.; H. B.

Knox, Jr., supt.; S. S. Daniel, buyer; Men's  
Seamless Half Hose; 18 knitting ma-  
chines; 3 sewing machines; steam; sell  
direct. (Buy 14 to 20 cotton.)

**Worthville. B-6. S. Ry. Co.**

**WORTH MFG. Co., THE;** Mill No. 1; \$200. (**C**)  
000; Hal. M. Worth, pres.; J. W. McAlis-  
ter, sec. treas. and supt.; Sheetings,  
Seamless Bags; Yarns, 6s to 24s; 5,852 ring  
spindles; 132 broad, 68 narrow and 24 bag  
looms; steam and water; O. M. Harper, N.  
Y., s. agt. for sheetings; Robinson-Hughes  
Co., Louisville, for bags; sell yarns, di-  
rect. (Freight address Randleman and  
Milboro.) (See Central Falls for Mill No.  
2.)

**WORTH MFG. Co.;** Mill No. 3; (formerly (**C**)  
Engleworth Mills); Sam'l E. Bostick,  
supt.; Colored Cottons; 102 looms; steam;  
Farish-Stafford Co., N. Y., s. agts. (See  
main office, mill No. 1.)

**Zirconia. B-3. Sou. Ry.**

**GOLD CROWN HOSEIERY MILLS;** (form. (**K**)  
erly at Charlotte, N. C.); Men's, Ladies'  
and Misses' Seamless Ribbed Hosiery,  
Black and Colors; 140 knitting machines;  
steam; dye; sell direct. (Spinning plant  
sold.)

## NORTH DAKOTA.

No map.

For explanation of abbreviations see page 66.

**Fl-mark.. N. P. RR.**

**STATE PENITENTIARY;** N. E. Boucher, (**C**)  
warden; W. E. Stiles, supt.; Binder Twine  
and Rope; 100 spindles; steam; sell direct.

**Grand Forks. G. N. RR.; N. P. RR.**

**GRAND FORKS WOOLEN MILLS;** Geo. B. (**W**)  
Clifford, pres.; A. P. Clifford, treas. agt.  
and buyer; Blankets, Blankets, Shawls,  
Dress Goods and Tweeds; 3 sets; 20  
looms; steam; dye; sell direct; (buy cot-  
ton warps, 18s single and 60s two ply.)

## OHIO.

See map on page 94.

For explanation of abbreviations see page 66.

**Akron. B.H. B. & O. RR.; C. A. & C. RR.;**  
N. Y., L. E. & W. RR.; P. & W. RR.; P. A.  
& W. RR.; V. RR.

**AKRON TWINE & CORDAGE Co.;** \$100,000; (**F**)  
R. H. Wright, treas.; L. A. Miller, mgr.;  
Cordage and Twine; 162 spindles; steam  
and electricity.

**Ashland. C-10. N. Y., L. E. & W. RR.**

**ASHLAND FLAX MILL Co.;** \$100,000; J. (**F**)  
Cahn, pres.; J. O. Jennings, treas.; J. W.  
Sharick, mgr., supt. and buyer; Uphol-  
stering Tow.

**Ashtabula. A-H. (Not shown on map.) N.**  
Y. C. & St. L. RR.; Penn. RR.

**ASHTABULA WORSTED MILLS;** E. W. (**W**)  
Savage, pres.; A. Dalin, vice pres. and  
treas.; Fred A. Briggs, sec.; Chas. E.  
Briggs, gen'l mgr.; Waistings, Dress  
Goods, Worsted Suitings. (Bullding will  
not be ready for machinery before July 1,  
'02).

**Barnesville. D-II. B. & O. RR.**

**BARNESVILLE HOSEIERY Co.;** W. H. Ander. (**K**)  
son, sec. and treas. *Burned April, 1901.*  
*Will not rebuild.*

**KAPNER BROS. & DUGA HOSEIERY Co.;** (**K**)  
THE; Cotton Hosiery. (Branch mill.) (See  
Dresden.)

**Beck's Mills. C-10. B. & O. RR.; C. A. & C.**  
RR.

**TROYER, SIMON D.;** Jeans, Blankets, (**W** & **K**)  
Flannels, Cassimeres, Stockings and  
Skirts; 1 set; 5 looms; 15 knitting ma-  
chines; steam and water; dye; sell direct.  
(R.R. station Millersburgh.)

**Bowling Green. B-9. C. H. & D. RR.; T.**  
& O. C. RR.

**SUPERIOR UNDERWEAR Co.;** Men's (**K**)  
Ribbed Underwear, Union Suits, Sum-  
mer and Winter Weights, in cotton, fl-  
wool, worsted and mixtures; 7 knitting  
machines; J. P. Spiker, buyer.

**Bucyrus. C-9. T. & O. C. RR.; C. S. & H.**  
RR. Penn. RR. .

**BROEMEL, A.;** Blankets, Flannels and (**W**)  
Stocking Yarns; 1 set; 2 looms; steam;  
dye.

**Canton. C-II. C. & M. E. RR.; C. C. & S. RR.;**  
P. RR.; V. RR.

ALEXANDER, L.; Woolens; 1 set. (**W**)

**Chillicothe. E-9. N. & W. RR.; C. H. & D.**  
RR.; B. & O. RR.

**CHILlicothe HOSEIERY MILLS;** 411 Mill (**K**)  
St.; W. S. Rowan, prop; Men's and Wo-  
men's Hosiery; 6 knitting machines;  
steam. *Not running.*

**Cincinnati. E-S.**

**ADLER & Co.;** Fairmount Woolen Mills, (**K**)  
108 West Pearl St.; J. H. Snyder, supt.;  
Underwear, Men's and Women's Woolen  
Hosiery; 80 hosiery and 24 underwear  
knitting machines; 10 sets; steam; dye;  
sell direct, and Cooley, Turnbull & Co.  
(underwear) and Wm. Iselin & Co. (hos-  
iery); N. Y. s. agts.

**ALBRECHT, C. H. & Co.;** 615 Main St. (**S**)  
Fringes; 20 looms; sell direct.

**ATRINS & PEARCE MFG. Co., THE;** Eggel. (**C**)  
ston Ave; \$25,000; H. T. Atkins, pres; N. S.

Clark, treas.; R. T. Pearee, vice-pres.; Colored and White Warps and Hosiery Yarns, Cordage, Twisted and Braided Goods; steam and water; dye; sell direct.

**AUREEEN, JOHN;** 1211 Harrison Ave.; (**K**) Seamless Hosiery; 8 knitting machines.

**BACHARACH & LOEB;** 2d and Ludlow Sts.; (**K**) Seamless Wool and Merino Hosiery; 75 knitting machines; steam; Hinchman, Vezin & Co, s. agts.

**DORMER BROS. CO., THE;** 331 W. 3rd St.; (**K**) \$60,000; Edward M. Marks, pres. treas. and buyer; Seamless Hosiery, Mittens, Children's Underwear; 250 knitting machines; steam; dye; E. M. Townsend & Co, N. Y., s. agts, children's underwear; John M. Given, Pittsburg, hosiery and mittens. (Buy cotton, wool, merino and worsted yarn.) Mills in Cincinnati and New Richmond.

**FRANKLIN COTTON MILL;** Pearee, At- (C) kins & Co; Plum, cor. Charles St; John Hillton, supt; Narrow Webbing, Cotton Belting, Sash Cord, Shade Cord, Clothes Lines, Plow Lines, Halters, etc; 63 looms; 146 braiders; steam; dye; sell direct. (Buy No. 8, 3, 4, 7 and 12 ply yarn.) *Wm C. Cochran, Assignee. Running under assignee by order of the court.*

**GEIER, AUGUST;** 1728 Race St; Hosiery; (**K**) 8 hand knitting machines; sell direct. (Buys 2 and 3 ply yarn in skeins and 1/16 in cotton and 1/30 wool on cones only.)

**HEY, BENJ. & CO.;** 124-126 128 Broadway; (**W**) Wool Shoddies; 5 pickers; 15 sets; steam; dye.

**HOFFMEISTER, ALBERT F. CO.;** Fourth St; (**S**) \$50,000; Albert F. Hoffmeister, pres; G. Appenfelder, supt; Fringes, Braids, Gimps, etc; steam; pres, buyer.

**HOLMES, I.;** 642 Main St; Elastic Hosiery, (**K**) Supporters, etc.; 6 knitting machines; hand power; sell direct.

**JACOBS CORDAGE CO, THE;** Queen City (**J**) Twine Mills; Geo. Guckenberger, pres; Emil C. Peter, vice-pres. and treas; Fred Guckenberger, sec; Geo. Muenzenmaier, supt; Cordage, Twines, Packings, Sash Cords, Etc; steam; sell direct; Emil C. Peter, buyer. (Office, warehouse and mills at Harriet and Budd Sts; & C. H. D. RR.)

**MAISH, CHAS. A. & CO.;** Comfortables (C) and Cotton Batting; 3 sets; steam; sell direct.

**PITTON BROS.;** 93 13th St. (**D**)

**RAILWAY SUPPLY & MFG. CO., THE;** (C & W) 1242 Harrison Ave.; Jos. Joseph, pres.; Eli Joseph, treas.; M. Joseph, sec.; White and Colored Cotton Waste and Wool Waste; 5 machines; 3 pullers; 2 willows; 5 large presses; steam.

**STEARNS & FOSTER CO., THE;** 118 and (C) 120 East Canal St.; \$1,000,000; S. C. Foster, pres.; E. R. Stearns, treas.; Wm. S. Stearns, supt.; White and Black Wadding and Batting; steam; dye; Putnam, Hooker & Co, s. agts, bats. (Mills at Lockland.)

**TEITON HOSEY CO.;** \$10,000; S. L. (**K**) McHugh, pres; Joseph M. McHugh, treas; Woolen Hosiery; 20 knitting machines; 2 ribbers; sell direct; buy yarns.

**WEST, EDWARD;** 1013 Main St.; All Wool (**K**) Hosiery and Cardigan Jackets; 20 knitting machines; electric; sell direct.

**Clarks.** (C) 10. C. A. & C. RR.; also on B. & O. Br.

**ALTMAN WOOLEN MILLS;** A. A. (**W** & **K**) Aultman, agt; Cloths, Flannels, Blankets, Skirts, Yarns, Etc; 1 set; 3 looms; 2 knitting machines; steam and water; dye. *Not running; for sale.* RR. station, Millersburg.)

## Cleveland. B-I-I.

**ACME WOOLEN MILL CO.;** 60-80 Bartlett (W) St.; \$50,000; P. S. Green, pres; C. P. Green, treas.; L. Reese, supt; Shoddy; 10 sets; 3 sets Garnetts; 6 pickers; steam; dye; sell direct; H. J. and C. P. Green, buyers

**BECKMAN CO, THE;** Northern Ohio Blam- (W) ket Mills; 27-33 Pleasant St.; \$200,000; H. Tiedemann, pres.; A. J. Tiedemann, sec. and treas.; Frank H. Mehling, gen'l mgr.; Fancy Lap Robes, Meltons, Horse and Bed Blankets; 10 sets; 115 looms; steam; dye; sell direct.

**CENTRAL KNITTING CO.;** Mittens, Fasci- (K) nators, Shawls, Hoods, Hand and Machine Goods of All Kinds; 150 knitting machines; steam; sell direct.

**CLEVELAND WORSTED MILLS CO.;** (for (W) merly Turner Worsted Co.); 1742 Broadway; \$800,000; O. M. Stafford, pres; Kaufman Hays, treas; G. H. Hodgson, supt; Worsted Yarn, Light Weight Men's Wear and Dress Goods; 10 worsted cards; 6500 worsted spindles; 8 combs (Bradford System); 300 looms; steam; dye; sell direct and M. H. Meinhard & Co., s. agts.; men's wear; Spielmann & Co., dress goods; G. H. Hodgson, buyer. (Buy 2/26 1/4, 2/30 1/4, 2/36 3/8, 2/40 1/2, 2/52 Aust.)

**COLLINGS, TAYLOR CO, THE;** Clarkwood (W) Ave.; Cleveland Woolen Mills; G. E. Collings, pres. and treas; Chas. Taylor, vice-pres. sec. and buyer; Shoddy; 12 sets; 10 pickers; steam; dye; sell direct; offices Little Falls, N. Y., Phila. and Ashmont, Mass.

**DIEMER, GEO. C.;** 316 Seneca St; Worsted (K) and Woolen Mittens, Gloves, Etc; 65 knitting machines; sell direct to jobbers.

**FRANZ, JOHN;** 25 Oregon St; Gustav (S) Franz, supt and buyer; Fringe, Curtain Loops, Cord and Tassels, Billiard Poek-ets; 6 looms; hand power; sell direct.

**FRIEDLANDER, M.;** 72 Frankfort St.; Silk (K) and other Mittens; 10 knitting machines.

**FRIEDMAN, H., & CO.;** 21-29 Bank St; (K) Hosiery, Mittens, Gloves, Fancy Knit Goods; 300 knitting and sewing machines; steam; dye; sell direct; H. Friedman, buyer.

**HESLER, EM. SURGICAL INS. CO.;** 52-54 (K) Public Square; Elastic Hosiery.

**MUHLHAUSER, F. CO.;** 16 Pleasant St.; (W) Wool Stock and Custom Carding; Fine Wool Shoddies; 62 cards; 16 pickers; steam; dye. *Petitioned into bankruptcy, Feb. 02. Sold under foreclosure Apr. 15, 02.*

**RICH, N. J. & CO.;** 33 Bright St; Mittens, (K) Fascinators, Shawls, Hoods, Sacques, Bootes, Toques, Gloves, Mittens; 40 cylinders; 250 knitting machines; 35 broad gauge; 60 sewing machines; electricity; sell direct; N. J. Rich and A. J. Farber, buyers.

**SAELTZER WOOLEN CO, THE;** \$50,000; (W) Otto A. Saelzter, pres; Chas. Saelzter, treas; Frank Reisdorph, supt; Wool Shoddies and Extracts; 14 sets; 5 pickers; steam; dye; sell direct; Otto A. Saelzter, buyer.

## Columbus. D-9.

**ARMBRUSTER, WILLIAM;** Woolen and (K) Cotton Seamless Hosiery, Woolen Mittens; 65 knitting machines; steam; sell direct.

**COLUMBUS WOOLEN MILLS CO.;** \$30,000; (W) Otto O. Bick, pres; David Shertzer, treas; C. R. Maddock, supt; Skirtings, Blankets, Flannels, Yarns; 3 sets; 10 broad and 7 narrow looms; steam; dye and finish; sell direct.

**FERGUSON, L. M.;** 263 N. 5th St.; (W) John Hayes, supt; Rugs made from old Carpets; 12 looms; steam; dye; sell direct; L. M. Ferguson, buyer. (Buy 4/8 cotton in warps.)

- Covington.** D.S. C. H. & D. RR.; P. RR.  
**COVINGTON WOOLEN MILLS;** (formerly (W) Mrs. Alfred J. Lewis); W. J. Lewis, supt.; All Wool Blankets; 1 set; 6 looms; water; dye; sell direct; C. E. Lewis, buyer. (Buy floss and worsted yarn.)
- Dayton.** D.S. C. H. & D. RR.; C. C. & St. L. RR.; D. L. & C. RR.; H. A. RR.; N. Y., L. E. & W. RR.; P. RR.  
**BRADLEY CORDAGE CO;** 448-464 Hoffman Ave.; \$150,000; J. E. Lowes, pres.; J. R. Mann, treas. and sec.; R. A. Myers, supt.; Binder Twine; 120 spindles; steam.  
**NATIONAL SOLDIERS' HOME; Knit Goods.** (K) **PAYNE, WM. H.;** Western Fibre Co.; Fort Scott, Kan.; Flax Fibre for Spinning and Upholstering; sell direct.  
**Defiance.** B.S. W. RR.; B. & O. RR.  
**DEFIANCE WOOLEN MILLS;** 2 sets; steam (W) and water; dye. *Reported not running.*  
**PIONEER BUFFALO COAT CO;** (Detroit, (W) Mich.); 2 sets; 8 knitting machines; steam; and water; dye. (Buy worsted and woolen yarns.) (Formerly Nightingale Woolen Mills.) *See Detroit.*
- Dresden.** D-10. C. & M. V. RR.; C. C. & S. RR.  
**DRESDEN WOOLEN MILLS;** J. Shore & (W) Sons; Flannel Cloths, Skirts, Cassimeres, Yarns, Blankets, Jeans; 2 sets; 15 looms; water and steam; dye.  
**KAPNER BROS. & DUGA HOSIERY CO.;** (K) \$50,000; J. Kapner, pres. and treas.; Cotton and Woolen Hosiery; 3 sets; 880 spindles; 100 knitting machines; steam; dye; Wm. Iselin & Co., N. Y., s. agts.; John H. Miller, buyer. (Buy cotton yarn, Nos. 10, 12, 14 up to 20.) (Operating branch mill at Barnesville, O.)
- MUSKINGUM VALLEY WOOLEN MFG. CO.;** (W) \$100,000; J. S. Prettyman, pres. and treas.; P. C. McGovern, vice-pres. and sec.; Messrs. Prettyman and McGovern, buyers; Cassimeres and Cloakings; 2 sets; 20 looms; steam; dye; sell direct.
- Edon.** B.S. W. RR.  
**SHELINE, E. R.;** Edon Woolen Mills; (W) Woolen Yarns, Flannels and Blankets; 1 set; 4 looms; steam; dye.
- Elyria.** B-10. C. B. E. & O. RR.; C. L. & W. RR.; L. S. & M. S. RR.  
**FAY STOCKING CO. THE;** \$75,000; W. L. (K) Fay, pres.; J. C. Hill, treas.; J. D. Partillo, supt.; Fay Stockings for Women and Children and Men's Half Hose; 65 knitting machines; steam; dye; sell direct; W. L. Fay, buyer. *Burned, March, 1901. Rebuilt.*
- Fredericksburg.** C-10. C. A. & C. RR.  
**LYTLE, JOHN T.;** Blankets, Flannels, (W) Skirts, Cassimeres and Yarns; 1 set; 200 ring spindles; 4 broad looms; water and steam; dye; sell direct; John T. Lytle, buyer. *Mill for sale.*
- Glandorf.** B.S. P. F. W. & W. RR.  
**GLANDORF WOOLEN MILL;** Ellersbrook, (W) Uphaus & Co.; Flannels, Blankets, Cassimeres, Satinets, Tweeds, Jeans, Yarn; 2 sets; 6 looms; steam; dye; sell direct.
- Hamilton.** E.S. C. H. & D. RR.; P. RR.  
**MIAMI WOOLEN MILLS;** Shuler & Ben- (W) nighofen; Paper Makers' Feltings; Yarns, Skirts, Flannels, Blankets; 4 sets; 24 broad looms; steam; dye; G. M. Gross Co., Chicago; R. B. Sterritt, Pittsburgh, and S. S. Stubbs, N. Y., s. agts.
- NEDERAUER, HENRY;** Miami Valley (K) Knitting Mill; Women's, Children's and Infants' Underwear in Cotton, Wool and Merino; 30 knitting machines; 52 sewing machines; steam; sell direct, and S. Hazard Halsted, Cincinnati, s. agt.
- PIONEER KNITTING MILLS CO. THE;** \$100,000; Peter E. Schwab, pres.; E. O. Boli, treas.; Ladies' and Children's Circular and Swiss Ribbed Underwear; Ladies' and Men's Union Suits a Specialty; 15 knitting machines; 20 finishing machines; steam and water; sell direct.
- Hillsboro.** E-9. B. & O. RR.; C. P. & V. RR.  
**HILLSBORO WOOLEN MILLS;** Will Ben- (W) nett, supt.; Flannels, Flannel Skirts, Jeans, Yarn, Etc.; 2 sets; 8 looms; steam; dye; sell direct. *Not running at present*
- Holmesville.** C-10. B. & O. RR.; C. A. & C. RR.  
**ADAMS, H. H.;** H. H. Adams, buyer; (W) Cassimeres, Flannels, Skirts, Blankets; 1 set; 4 looms; water; dye; sell direct.
- Lancaster.** D-10. C. M. & V. RR.; C. H. V. & T. RR.  
**HANBERGER KNITTING MILLS;** G. A. (K) Hanberger, agt., supt. and buyer; Half Hose and Women's Hosiery, Cotton and Wool; 40 knitting machines; 6 ribbers; 4 loopers; steam; dye; sell direct.
- MCANESPIE, JAMES & CO.;** Blankets, (W) Flannels, Cassimeres, Yarns; 2 sets; 7 looms; steam; dye and finish.
- Louisville.** C-11. P. RR.  
**CARPENTER HOSIERY CO.;** M. O. Sherer, (K) pres.; J. R. Stopfer, treas.; All-Wool Shaker Hosiery; 1 set; 22 knitting machines; steam; dye; sell direct. *Idle.*
- Madisonville.** E.S. (Station M. Cincinnati).  
**MADISONVILLE WOOLEN MILLS CO.;** \$50,000; Henry Kressel, pres.; Ed. K. Poor, treas.; Dan'l Fallain, supt.; Cassimeres, Blankets, Ladies' Dress Goods; 5 sets; 1500 mule spindles; 30 looms; steam; dye; Henry Kressel, buyer.
- Magnolia.** C-11. P. RR.  
**CHADDOCK, G. W. & SONS;** Blankets, (W & K) Flannels, Skirts, Satinets, Cassimeres and Yarns; 1 set; 5 looms; steam; dye; sell direct.
- Mansfield.** C-10. B. & O. RR.; N. Y., L. E. & W. RR.; P. RR.  
**MANSFIELD ELASTIC WEB CO.;** Arthur (C) B. and Thos. Martin; Arthur B. Martin, buyer; Suspender Webs; 30 looms; steam; sell direct. (Buy 12 2, 24 2, 40 2, 16/2, 12 3-32 skeins, 6-tubes.)
- Marion.** C-9. Erie RR.; C. C. C. & St. L. RR.  
**SUSQUEHANNA SILK MILLS;** \$150,000; H. (S) Schwiewind, Sr., pres.; H. Schwiewind, Jr., treas. and buyer; H. Klern, agt. and supt.; Broad Silks; steam; Oelberman, Dommerich & Co., s. agts. *Start up Sept. 1902.* (Also see Sanbury, Penn.)
- Mechanicsburg.** D-9. C. C. C. & St. L. RR.  
**MICKLE & CHENEY;** F. A. Cheney, (W & C) supt.; Woolen and Cotton Comforts; 2 sets; steam and water; Putnam, Hooker & Co., Cincinnati, O., s. agts.; J. Mickle, buyer.
- Mentor.** A-H. N.Y. C. & St. L. RR.; L. S. & M. S. RR.  
**MENTOR KNITTING MILLS CO. THE;** (K) \$50,000; Sam. R. Sague, pres. and gen'l mgr.; W. C. Spaulding, treas.; High Grade Ladies' Fleeced Lined Ribbed Underwear; 50 knitting machines; steam; sell direct; president, buyer. (Buy 88 to 128 Pc per and Egyptian Full Combed on Cops.)
- Miamisburg.** D.S. C. C. C. & St. L. RR. C; H. & D. RR.  
**MIAMISBURG TWINE & CORDAGE CO.;** (F) \$200,000; N. J. Catrow, pres.; W. H. Albrecht, treas.; Frank Smith, sec.; W. E. Schieble, supt.; Binder Twine from Manila and Sisal Fibre; steam.
- Milan.** B-10. W. & L. E. RR.  
**BROWN, JOHN;** Milan Knitting Mill; (K) Men's Wool Socks; 1 set; 5 knitting machines.
- Millersburg.** C-10. B. & O. RR.; C. A. & C. RR.  
**AULTMAN WOOLEN MILLS.** *See Clerks.*

**Minster.** C-S. L. E. & W. RR.

MINSTER WOOLEN MFG. CO; Chas. Bens. (W) man, pres.; Louis Drees, treas. and gen'l mgr.; Cheviots and Meltons; 1 set; 25 looms; steam; dye; Hardt, Von Bernuth & Co., N. Y., s. agts.; Lewis Drees, buyer. (Buy 18 white cotton, warp yarn.)

**Mt. Vernon.** D-10. (Not shown on map.) B. & O. RR.

MCCONNELL, J. S. WOOL CO.; \$100,000; (W) J. S. McConnell and others; Woolen Goods. *Proposed.*

**Napoleon.** B-S. W. RR.

NAPOLEON WOOLEN MILLS; Augenstein (W) Bros.; C. F. Augenstein, supt.; Flannels, Skirts and Blankets; 2 sets; 6 broad and 4 narrow looms; steam and water; dye; sell direct; C. F. Augenstein, buyer.

**Newton Falls.** B-II. P. & W. RR.; A. & N. RR.

STARR, W. E.; Western Reserve Woolen (W) Mills; Cassimeres, Flannels, etc.; 1 set; 3 looms; dye; water; sell direct.

**New Bremen.** C-S. L. E. & W. RR.

BAKHAUS & KUENZEL CO, THE; \$75,000; (W) H. C. Kuenzel, pres.; Julius Gilberg, treas.; Henry Finke, supt.; Woolen Blankets; 648 wool spindles; 2 sets; 11 looms; steam and water; dye; Ryan & McGahan, 30-32 East 21st St., N. Y., s. agts.

**New Hope.** D-7. (Not shown on map.) RR. Station Riota. P. C. C. & St. L. RR. Rich. Br.

FITE, EDGAR; Yarns; 1 set. (W)

**New Richmond.** E-S. By water.

CLASGENS, THE J. & H. CO.; Clermont (W) Woolen Mills; \$125,000; Joseph Clasgens, pres.; F. H. Clasgens, treas.; Jos. Clasgens, buyer; Woolen and Merino Yarns for all purposes; 6 sets; 4000 spindles; steam; dye; sell direct.

DORNER BROS. CO, THE; Buckeye (K) Knitting Works; Mittens and Hosiery; 40 knitting machines; steam. (*Branch of plant at Cincinnati.*)

**Pandora.** C-S. N. O. RR.

AMSTUTZ, WELTY & CO; Woolens; 1 set; (W) 2 looms; steam.

**Piqua.** D-S. M. V. RR.; P. RR.; C. H. & D. RR.

ATLAS UNDERWEAR CO, THE; \$75,000; L. (K) M. Flesh, pres.; E. A. Todd, treas. and supt.; Men's and Women's Union Underwear in Cotton, Silk and Worsted; 40 knitting machines; sell direct and through agents; L. M. Flesh, buyer.

ORR FELT & BLANKET CO.; \$200,000; Gen. (W) Wm. P. Orr, pres.; Stanhope Bond, treas.; M. C. Burrell, agt.; Paper Makers' Felt and Jackets, California Blankets and Horse Blankets; 8 sets; 40 looms; steam; dye; sell direct; A. M. Orr, vice-pres., buyer. (Purchased F. Gray Co.'s plant.)

PIQUA HOSIERY CO, THE; \$25,000; J. M. (K) Cahill, pres.; W. K. Leonard, treas.; Men's and Women's Underwear; 50 knitting machines; steam.

SUPERIOR UNDERWEAR CO. *See Bowling Green.*

UNION UNDERWEAR CO.; John L. Boyer, (K) prop.; H. K. Harvey, supt.; Ladies' and Men's Union Suits; 25 knitting machines; 23 sewing machines; steam; sell direct; J. L. Boyer, buyer.

**Roscoe.** C-10. Penn. RR.

L. E. RETZLEY, T.; Woolen Socks; (about (K) 200 doz. per day.)

**St. Mary's.** C-S. L. E. & W. RR.

ST. MARY'S WOOLEN MFG. CO.; (W) \$50,000; (\$85,000 surplus); A. Althausen, pres.; E. M. Veenhoff, treas.; Albert Herzing, sec.; W. H. Swift, supt.; Treas.

buyer; All Wool Blankets; 3 sets; 20 looms; steam and water; dye; C. H. Swearington, Pittsburg; Wohlmueter & Champness, Chicago; C. H. Hamilton, N. Y., s. agts.

**Smithville.** C-10. W. & L. E. RR.

MISLER, JOHN; Cheese Cloths and Cot. (C) ton and Hemp Cider Press Cloths; 5 looms; 2 sewing machines; gasoline engine; C. J. Miller, Smithville, s. agt. (Buy carpet warp, 5 to 7 ply, plain cotton white and also hemp yarns and woolen yarns.)

**Stafford.** D-II. B. Z. & C. RR.

DANIELS, JOHN; Flannel, Jeans, Blankets, Stocking Yarn; 1 set; 4 looms; steam; dye; sell direct. (RR. stations, Pryor and Louisville, 7 miles distant.)

**Sugar Creek.** C-II. C. C. & S. RR.

FISHER, F. & SONS; Emeka Woolen (W & K) Mills; J. F. Fisher, treas.; F. Fisher, supt. and buyer; Blankets, Skirts, Knitting Yarns, Etc.; 1 set; 4 looms; 2 knitting machines; steam; dye; Frank Weaver, s. agt.

**Tiffin.** B-9. B. & O. RR.; C. C. C. & St. L. RR.; P. RR.

TIFFIN WOOLEN MILLS; Balbian Bros; (W) Cassimeres, Cheviots, Friezes, Meltons, Worsteds, Carriage Robes and Blankets; 6 sets; 2400 spindles; 32 broad looms; steam; dye; H. Bauendahl & Co, N. Y., s. agts. (*In hands of receiver March, 1902.*)

TOLEDO. B-9. C. H. & D. RR.; C. J. & M. RR.; C. H. V. & T. RR.; L. S. & M. S. RR.; M. C. RR.; P. RR.; T. & O. C. RR.; T. St. L. & K. C. RR.; T. A. A. & N. M. RR.; W. RR.; W. & L. E. RR.

OHIO KNITTING MILLS CO.; 123 & 125 (K) Summit St.; M. Rosenberg, pres.; J. W. Mason, sec.; Fancy Knit Shawls of all kinds; Gloves, Mittens and Infant's Wear; sell direct.

PEARLESS KNITTING MILLS CO.; \$25,000; (K) J. Hubert, pres. and treas.; Wool and Silk Mittens, Gloves, Shawls, Fascinators and Infant's and Children's Knit Wear; 110 knitting machines; steam and electricity; sell direct.

ROTH, JOS. & CO; Enterprise Knitting (K) Works; Fred Friedlander, supt.; Mittens, Gloves, Infant's Vests and Hose; 200 knitting machines; electricity; sell direct; Jos. Roth, buyer.

TOLEDO KNITTING CO.; Mittens and (K) Gloves; 60 knitting machines; steam; sell direct.

**Urbana.** D-9. C. C. C. & St. L. RR.; N. Y., L. E. & W. RR.; P. RR.

FOX, HENRY & CO; Urbana Woolen (W) Mills; Chas. Holding, supt.; Cassimeres and Cheviots; 5 sets; 1200 spindles; 17 looms; steam and water; dye; E. B. Hall, mgr. and s. agt. (Buy 1/2 to 40/2 cotton yarns.)

**Vinton.** E-10. C. H. V. & T. RR.

SHACK, GEO. W.; Yarns; 1 set; steam (W) and water; sell direct.

**Wakaponeca.** C-S. C. H. & D. RR., C. L. & N. RR.

WAPAK KNITTING CO., THE; Jos. J. Wal (K) ter, sole prop.; Knit Goods, Men and Women's Union Suits a Specialty; 5 knitting machines; gas engine; sell direct and J. H. Conover, N. Y., s. agt.; Jos. J. Walter, buyer. (Buy yarn.)

**Washington.** D-9. Balt. & O. RR.; Ohio So. RR.

PEDDICORD, INSKIP & HESS; Gloves (K) and Mittens; 75 sewing machines; gas; sell direct. (Buy yarn.)

**West Alexandria.** D-S. C. J. & M. RR.

FOUTZ, E. C., & BRO; Blankets and Flannels; 1 set; 5 looms; steam; dye; sell direct.



- West Andover.** A-II. L. S. & M. S. RR.  
**FITTS, BROS.**; Blankets, Flannels, Knit- (W) ting Yarn; 1 set; 6 looms; steam and water; dye; sell direct.
- West Milton.** D-S. C. H. & D. RR.  
**RUTLEDGE, WM. & SON**; Chas. Rutledge, (W) supt.; Flannels, Blankets, Yarns; 1 set; 4 looms; water; dye.
- West Unity.** B-S. C. J. & M. RR.  
**UNITY MILL Co**; Rbigs & Beach; (K) Yarn and Woolen Hosiery; 1 set; 12 knitting machines; steam; dye; sell direct. *Not running.*
- Wheelerburg.** E-10. N. & W. RR.  
**CRANSTON, BENJ, WOOLEN MILLS**; (W & K) Yarn, Flannels, Blankets; Seamless Hosiery; 2 sets; 6 looms; 6 knitting machines; steam; dye.
- Willoughby.** A-12. N. Y. C. & St. L. RR.; L. S. & M. S. RR.  
**DODD BROS.**; Flannels, Blankets and (W) Hosiery Yarns; 2 sets; 4 looms; water; dye; sell direct.
- Wilton.** C-II. C. C. & S. RR.; W. L. E. RR.; C. L. & W. RR.  
**LENZ, J. F.**; Cassimeres, Skirts and (W) Knitting Yarn; 1 set; 5 looms, steam; dye; sell direct. (RR. station, Beach City.) (Buy some Mohair yarns.)
- Xenia.** D-S. C. H. & D. RR.; P. RR.  
**HOOVEN & ALLISON Co.**; \$300,000; J. H. (F1) Harbime, pres.; J. D. Steele, treas; Manila and Sisal Binder Twine and Rope; Hemp, Jute and Cotton Twines and Cordage; steam; N. Warren, St. Louis, s. agt.
- KELLY, R. A. COMPANY**; \$100,000; Geo. R. (F1) Kelly, pres. and gen. mgr; G. E. Hudson, sec; 100 spindles.
- OHIO CORDAGE MILL** (Owned and ope. (F1) rated by Hooven & Allison Co.); 200 spindles.
- Zanesville.** D-10. B. Z. & C. RR.; B. & O. RR.; C. & M. V. RR.; C. A. & C. RR.; C. C. & S. RR.; C. S. & H. RR.; Z. & O. R. RR.  
**ZANESVILLE WOOLEN MANUFACTURING (W) Co.**; \$50,000; John C. Harris, pres.; Robt. Fulton, treas.; John L. Turner, supt.; All Wool Blankets, Flannels, Jeans and Linseys; 4 sets; 28 looms; steam; dye; sell direct; Jno. C. Harris and Jno. L. Turner, buyers.

## OREGON.

No map.

For explanation of abbreviations see page 66.

- Albany.** O. P. RR.; S. P. RR.  
**ALBANY WOOLEN MILLS**; \$50,000; Sam'l (W) E. Young, pres; P. A. Goodwin, sec; Joseph Woodhead, supt.; Cassimeres, Tweeds, Cheviots, Kerseys, Flannels, Blankets and Robes; 2 sets; 16 looms; water; dye; sell direct.
- Ashland.** S. P. RR.  
**ANDERSON, E. K. & G. N.**; (*Destroyed by (W) fire January, 1900. Will not rebuild.*)
- Bandon.** By ocean steamships.  
**BANDON WOOLEN MILLS Co.**; \$75,000; T. (W) W. Clark, pres.; H. Z. Burkhardt, sec.; F. E. Palmer, supt.; Blankets, Flannels, and Cheviots; 3 sets; 11 looms; steam; dye; sell direct.
- Brownsville.** S. P. RR.  
**BROWNSVILLE WOOLEN MILL Co.**; (For (W) Eagle Woolen Mills Co.); Emil Kopp, supt.; All Kinds of Woolen Goods; 2 sets; 16 looms; water; dye; sell direct; Seth Raistrick, buyer.
- Dallas.** S. P. RR.  
**PIONEER WOOLEN MILL Co.** *Out of business. Machinery sold.*
- Eugene.** O. R. & N. Co.; So. P.  
**WILLAMETTE VALLEY WOOLEN MFG. Co.**; (W) \$60,000; R. McMurphy, pres.; H. D. Waggon, vice-pres.; F. E. Dnni, treas.; G. W. Hirst, sec. and mgr.; Cloth, Blankets, etc.; water; dye. (Also scour Wool.)
- Oregon City.** S. P. RR.  
**OREGON CITY MFG. Co.**; \$400,000; A. R. Ja- (W) cobs, pres.; R. Koerner, supt.; C. G. Jacobs, buyer; Cassimeres, Blankets, Shawls, Flannels, Carriage Robes; 14 sets; 60 looms; water; dye; sell direct; N. Y. office, 349 Broadway.
- Pendleton.** Union Pacific RR.  
**PENDLETON WOOLEN MILLS**; \$40,000; E. (W) Y. Judd, pres; F. E. Judd, treas; Geo. D. Fell, supt. and buyer; Indian Robes and Blankets; 2 sets; 11 looms; steam; dye; sell direct.
- PENDLETON WOOL SCOURING AND PACK. (W) ING Co**; \$40,000; E. Y. Judd, pres; F. E. Judd, treas. and supt.; Wool Scouring; steam; E. Y. Judd, buyer.
- Portland.** S. P. RR.; N. P. RR.; U. P. RR.  
**LUKE KNITTING Co**; \$10,000; Geo. A. (K) Luke, pres, treas, supt. and buyer; Wool, Cotton and Linen Hose; Underwear, Jackets, etc; 20 knitting machines; elec- tricity; sell direct. (Buy different yarns.)
- PORTLAND CORDAGE Co.**; \$100,000; S. M. (F1) Meurs, pres. and treas.; D. R. Young, sec.; Manila and Sisal Cordage and Harvesting Twine; steam; sell direct.
- PORTLAND WOOLEN MILLS**; \$50,000; W. (W) P. Olds, pres.; E. L. Thompson, treas.; Fred Carter, supt.; White Blankets, Fancy Woolens; 3 sets; 32 looms; steam; dye; O. H. Hayes & Co. N. Y., s. agts.; Fred Carter, buyer.
- Salem.** S. P. RR.  
**KAY, THOS., WOOLEN MILLS Co.**; \$100,000; Thos. B. Kay, pres; R. H. Coshow, treas; P. F. McGee, supt; Woolen Goods, Cassimeres, Tweeds, Cheviots, Flannels, Blankets and Wool Rolls; 3 sets; 30 looms; water; dye; sell direct; Thomas B. Kay, buyer.
- Stayton.** S. P. RR.  
**STATTON CARDING & SPINNING MILL; (W&K) J. B. Grier, supt.; Wool Rolls, Knitting Yarn and Hosiery; 1 set; 3 knitting machines; water; sell direct. (RR. station, West Stayton, three miles distant, and Kings, O. C. & E., 1 mile.)**
- The Dalles.** S. P. RR.  
**THE DALLES WOOL SCOURING MILLS Co.**; (W) J. M. Russell, pres. and mgr; Wool Scouring.
- Union.** O. R. & N. RR.  
**UNION WOOLEN MILL; A. E. Eaton, pres.; (W) J. P. Wilbur, supt.; Blankets and Robes; 2 sets; 10 looms; water; dye; sell direct; John P. Wilbur, buyer.**

**PATRICK O'NEILL & CO.,**DEALERS IN and  
GRADERS OF**Woolen Rags**Stock Prepared  
for Manufacturers  
Guaranteed as  
Represented.*Correspondence Solicited.***408-410 So. 6th St., - - - PHILADELPHIA, PA.****PHILADELPHIA AND SUBURBS.**

See maps on pages 204, 206, 208, 210, 212, 214.

*Pennsylvania, outside of Philadelphia and Suburbs, is classified separately and follows Philadelphia.*

Under the general head of Philadelphia are included all textile establishments, not only in the city proper, but in the local districts of Manayunk, Frankford, Kensington, Germantown, Bridesburg, West Philadelphia, Port Richmond, and Nicetown.

These establishments are arranged in alphabetical order, regardless of location or kinds of goods made. The street address is given and the district mentioned. When possible, the approximate location of each mill is determined by designating the map and square in which it is located.

**Map A** is a "skeleton map," showing the general location of the different mill districts, some of the principal streets and avenues, and railroads. It gives a general id. a. of the city, without attempting to show the streets. This map is the basis of the enlarged sectional maps which follow. Certain squares, embracing the most populous mill districts, have been enlarged in maps B, C, D, E, and F. These maps do not cover the whole city, but they do cover the majority of the mills. There are, however, quite a number of mills outside the sections embraced in the maps, and these mills have no map and square number.

**Map B** shows the principal down town business section.

**Map C** shows the Kensington and Richmond districts.

**Map D** shows a large part of Germantown.

**Map E** shows Frankford and vicinity.

**Map F** shows Manayunk, Fall of Schuylkill, etc.

**The Abbreviations** used are the same as in other parts of the directory.

The Directory of Philadelphia and suburbs has been compiled especially for the **TEXTILE WORLD**, by thorough personal canvass. The Publishers will esteem it a favor to be informed of any inaccuracies that may be discovered, or of any changes that may occur after publication.

**ABBOTT MFG. Co.**; Hancock & Somer. (W sets Sts.; Map A; Sq. 61; \$200,000; Fredrick C. Brunhouse, pres.; Chas. A. Fessler, treas.; Geo. Sidebotham, supt. and buyer; Men's and Women's Wear, Worsted Yarn 2/20 to 2/50; (Bradford system); 4 sets; 4 combs; 2400 worsted spindles; 40 looms; sell direct. (Operating Lincoln Worsted Mills.)

**ABERLE, HARRY C. & Co.**; 2623 Bodine (K St.; Fall Fashioned and Ribbed Cotton and Lisle Hosiery; 7 fashioned, 45 knitting machines; steam; Harrington & Waring, N. Y., s. agts.; Harry C. Aberle, buyer.

**ACHUFF, SAMUEL**; Achuff Knitting Mills; (K Kensington Ave. and Huntingdon St; Map C. Sq. 62; Ribbed Underwear; 40 knitting machines; 50 sewing machines; steam; sell direct; Bateson & Dowd, s. agts.

**ACKERMAN, W. M. & Bro**; 413 Orianna (K St.; Ribbed Cotton Hosiery; 30 knitting machines; steam; sell direct.

**ADAMS, JOSEPH M.**; Areola Mills; Main (W and Centre Sts.; Manayunk; Map F; Sq. 72; Carpet and Backing Yarns, Shoddy and Extracts and Wool Scouring; 22 sets; 3 garnett machines; 10 pickers; 1 carbonizing machine; 1 scouring machine; steam and water; sell direct; J. M. Adams, buyer.

**ADAMSON, JOS. & Co.**; Raleigh's Mill; (C Columbia and Germantown Ave; Map C; Sq. 53; Tapes and Webbing; 185 looms; steam; sell direct; Jos. Adamson, buyer.

**ADCOCK, JOSEPH**; 5004 Osceola St.; Ger. (K mantown Map D; Sq. 91; Fancy Woolen Gloves and Mills; 18 knitting machines; hand power; sell direct; Jos. Adcock, buyer.

**ADROIT DYE WORKS.** *Out of business.*

**AIMAN, RICHARD H.**; Coral and Adams (W St.; Map C; Sq. 62; (office, 675-677 The Bourse); Dress Goods; 32 looms; steam; sell direct; R. H. Aiman, buyer. (Formerly Aiman & Harper.)

**ALEXANDER, ANDREW**; 2031 Hancock St. (W Map C; Sq. 62; Ingrains; 20 hand looms; hand power; sell direct; A. Alexander, buyer.

**ALLEGHENY WORSTED MILLS.** See Wolstenholme, Thos. Sons & Co.

**ALLEN DYEING Co, THE**; (office, (D & B) 2848 Frankford Ave.); Works, Frankford Ave; above Hart Lane; Cotton and Woolen Yarns and Wares.

**ALLEN, J. & B.**; 4980 Sheldon St.; German. (K town; Map D; Sq. 92; Woolen Knit Goods, Cotton Hosiery and Elderdown Garments; 5 sets; 265 knitting machines; steam; sell direct; firm, buyers. (Phila. office, 14 N. 9th St.; N. Y. office, 35 and 37 Thomas St.)

**ALLEN, WM. & SON**; Howard St, below (W Lehigh Ave; Map A; Sq. 61; Jos. Hopkins, supt; Carpet Yarns, Railroad Waste and Carpet Shoddy; 6 sets; steam; sell direct; Geo. B. Allen, buyer.

**AMERICAN SEPARATOR ROPE Co.**; Row. (C land Ave. and Rhawn St.; \$25,000; Cotton Separator Rope, Mule Banding, Spindle Banding, Transmitting Rope, all kinds Cotton Braid; 10,000 spindles; steam; sell direct; D. J. Sweeney, buyer.

**AMERICAN SILK MFG. Co.** (office 311 Wal. (S mt St.) See Eden, Pa.

**AMERICAN TEXTILE Co.**; Church Lane (K and Lena St, Germantown; Cotton Hosiery; 120 knitting machines; steam; sell direct, 396 Broadway, N. Y.

- AMHERST KNITTING CO;** (successors to **(K)** John R. Bill); Clearfield and Jasper Sts; Map C; Sq. 71; \$10,000; John S. Tapscott, pres; John R. Bill, supt; Cotton Seamless Ribbed Hose; 91 knitting machines; steam; John S. Tapscott & Co, Balto, s. agts; John R. Bill, buyer.
- ANATOLIAN RUG MFG. Co;** Jones & **(W)** Green; Jasper St; North of Tioga St; Map E; Sq. 71; Smyrna Rugs; 60 looms; steam and hand power; W. & J. Sloane, N. Y.; s. agts; firm, buyers.
- ANGOLA DYEING CO;** Hancock & **(D)** Huntingdon Sts; Map C. Sq. 62; Fast Black on Knit Goods.
- ANGORA MFG. Co;** Angora Mill No. **(W)** 2; 60 St. and Baltimore Ave; Map A; Sq. 41; Angora Sta. P. W. & B. R.R. \$25,000; B. MacMackin, pres; Albert Callaghan, treas; Charles Callaghan, supt; Woolens; 12 sets; 200 looms; steam; Converse, Stanton & Co., s. agts.
- ARANSEA MFG. Co.** (Bristol St., near **(F)** L. Germantown Ave.); Flax Twines, Yarns and Threads; 4 to 20 lea; steam; dye.
- ARKONIA MFG. Co;** \$60,000; Ox- **(C, W & S)** ford and Hancock Sts; Map C; Sq. 54; (Jos. C. Sullivan, Albert Crenshaw & R. E. Crenshaw); Albert Crenshaw, supt. and buyer; Cotton, Woolen, Worsted and Silk Fabrics; 410 looms; steam; sell direct; N. Y. office, 51 Leonard St.
- ARMURE TAPESTRY MILL;** Mitchell & **(C)** Townson, prop.; 2739 Fairhill St.; Chas. B. Young (17th & B'way, N. Y.), agt.; Upholstery Goods and Drapery Novelties; 30 looms; steam; sell direct; Albert Mitchell, supt. and buyer.
- ART KNITTING MILL;** Louis Friedman **(K)** and Phillip Miller, props; 1424 Frankford Ave; Cotton Worsted and Woolen Sweaters and Cardigan Jackets; 10 knitting machines; 2 sewing machines; hand power; Thompson, Foust & Co., N. Y., s. agts.
- ARTMAN, TREICHLER CARPET CO, THE,** **(W)** E. R; Putnam Mills; Second and Huntingdon Sts; Map A, Sq. 61; \$40,000; E. R. Artman, pres; D. G. Endy, treas; S. J. Acheson, supt; Ingrains; 42 looms; steam; dye; sell direct; S. J. Acheson, buyer.
- ASHTON, JAS;** 2621 Collins St; Map **(W)** C; Sq. 62; Jas. Ashton, supt; Waste and Shoddy; steam; sell direct; Jas. Ashton, Jr, buyer.
- AXFORD, JOHN;** Novelty Knitting Mill; **(K)** 363 Price St; Germantown; Map D; Sq. 91; Patentee and Maker of "The Axford Cut" Ladies' Vests and Infants' Wrappers; 63 knitting machines; steam.
- AYRES, WM, & SONS;** Third and Cumber-**(W)** land Sts; Map A; Sq. 61; Horse Blankets; 12 sets; 175 looms; steam; 220 Chestnut St., 332 Broadway, N. Y.; 164 Federal St, Boston; 256 & 258 Madison St, Chicago, and 23 Davis St, San Francisco.
- BAILEY, C;** 810-818 Swanson St; P. H. **(J)** Guard, supt. and buyer; Cordage; steam.
- BAILLY, JOHN T., & Co;** Front and Tasker **(J)** Sts; Map A; Sq. 29; Bag Rope and Twine Mfgs; steam; sell direct; John T. Bailey & Co, buyers.
- BAKER, A. T., & Co;** Main St; Mana-**(W)** yunk; Map F; Sq. 73; Corloury, Velvets and Velours, Mohair Pushes; 35 looms; water; sell direct; A. T. Baker, buyer.
- BAKES, E;** Davenport Mills; Mascher and **(W)** York Sts; S. Baker, mgr; Chenille Table Covers; 14 looms; Theo. Abbott, Phila. & N. Y., s. agt.
- BALL, H. C., & Co;** Wissalnickon Worsted **(W)** Mills; Main St; Manayunk; Map F; Sq. 65; Worsted Yarns (English System); 5 cards; 5 combs; 5000 spindles; steam; Thos. H. Ball, 256 Chestnut St., s. agt; H. C. Ball, buyer.
- BALLANTYNE, JOHN & SONS;** Hawick **(K)** Knitting Mills; 161 Ashmead St; Germantown; Map D; Sq. 91; Plain Cut and Fancy Seamless Hosiery; 270 knitting machines; steam; sell direct; Alexander Ballantyne, buyer.
- BALTZ BROS;** Agts; Ripka Mills; Main **(W)** St, Manayunk; Map F; Sq. 73; Carpet Yarns; 5 sets.
- BANNER, THOMAS** (Est. of); 3416 Frank-**(C)** ford Ave.; Map E; Sq. 71; Banding; 150 spindles; steam; sell direct.
- BANNISTER, GEORGE;** 82 and 84 Arbut **(K)** St; Germantown; Map D; Sq. 91; Fancy Knit Goods, Skirts, Leggings, Bicycle Hosiery, Eiderdown Sacques and Robes; 11 knitting machines; 15 sewing machines; steam; D. W. Shoyer & Co, N. Y., s. agts; Geo. Bannister, buyer.
- BARBER, GEO;** Allegheny and Kensing **(W)** ton Aves; Map E; Sq 71; Double Reel Carpet Yarns; 950 mule spindles; 2 sets; sell direct.
- BARBER, J. W. & Co;** Allegheny Ave. and **(S)** C St; Upholstery Goods, Curtains and Novelties; 20 looms; steam; sell direct. J. W. Barber, buyer.
- BARLOW, NOAH;** 5309-15 Westminster Ave; **(S)** West Phila; Map A; Sq. 41; Tapestries and Chenille Goods; 42 looms; steam; L. S. Smith, 276 Canal St, N. Y., s. agt; also direct; N. Barlow, buyer.
- BARNES & BEYER.** *Out of business.* (Plant purchased by the Bromley Bros. Carpet Co.)
- BARR MFG. CO;** 4th & Somerset Sts; **(W)** Map A. Sq. 61; (D. M., Geo. and Jas. Barr and Geo. Olden); Cotton Worsteds for Men's Wear; 72 looms; steam; Diamant & Ehrenberg, 53 Leonard St, N. Y., s. agts.
- BARRETT, WM;** Pilling St; Frankford; **(B)** 1 Map E; Sq. 80; Bleacher Cotton Yarns, Hosiery and Cotton Goods; steam.
- BARROWS, DAVID, & SON;** 3968 German-**(K)** town Ave; Map A; Sq. 76; (P. O. address Nictown); Fancy Woolen Knit Goods; 25 knitting machines; steam; sell direct; David Barrows, buyer.
- BARROWS & DOUNTON;** 18th St. and Ger **(J)** mantown Ave; Map A, Sq. 76; Fishing Lines, Cotton and Linen Harness Twines; steam; John Barrows, buyer.
- BATEMAN, Wm;** Frankford; W. Bate-**(W)** man, supt; Dress Goods; 32 looms; steam; sell direct. (Buys 1/12s to 1/30s, 2/10s to 2/60s worsted yarns.)
- BATTY'S, JOB, SONS CO, (LTD);** Emerald **(W)** Mills; Emerald and Adams St; Map C; Sq. 62; Carpet Yarns and Wool Shoddies; 18 sets; 6 pickers; 4 garnett machines; steam; sell direct; the firm, buyers.
- BEARDWOOD, THOMAS, & BRO;** 1640 N. 6th **(D)** St; Map C; Sq. 53; Finishers; steam; dye.
- BATTERY, ROBT. & CO;** Coral and Adams **(C)** Sts; Map C; Sq. 62; Fine Cotton Yarns; 16,814 spindles; steam; sell direct; Robt. Battery, buyer.
- BECHMANN, GEO. F., & SON;** 69th **(C, W & S)** and Haverford Ave; Map C; Sq. 61; Velvets and Pushes; 43 looms; steam; dye; sell direct; Wm. Bechmann, buyer.
- BECHTOLD, ALBERT;** Mascher and Ox-**(P)** ford Sts; Map C; Sq 54; Hosiery Printing; steam.
- BELCHER, HARRY;** 1731 Gillingham St; **(C)** Sts, Frankford; Table Damask; 8 looms; steam; sell direct.
- BELKNAP, F. C. F.;** 333 Chestnut St; Silk **(S)** Braids, Gimps, etc; 15 looms; electricity; sell direct.

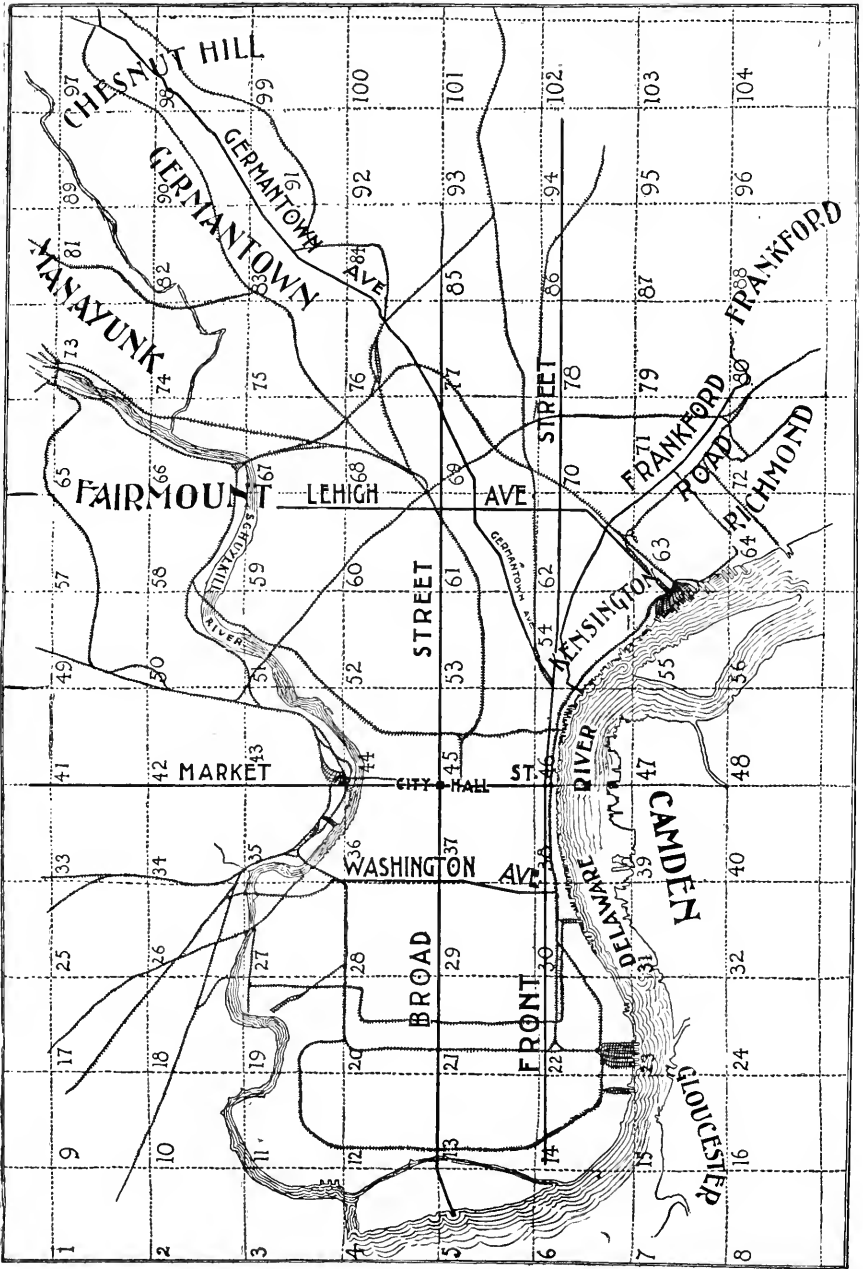

MAP A—GENERAL PLAN OF PHILADELPHIA AND SUBURBS.

- BENNETT, WM;** Eagle Hosiery Mills; (**K**) American and Diamond Sts; Map C; Sq. 61; Cut and Seamless Hosiery; 110 knitting machines; steam; sell direct; Wm. Bennett, buyer.
- BERGES, J. & Co;** 2023 Amber St; Map C; (**D**) Sq. 62; Wool and Worsted Skein Dyers; steam.
- BERKSHIRE MFG. CO. (LTD);** Church St; (**C**) Frankford; Map E; Sq. 80; \$50,000; Jno. B. Morgan, pres; T. W. Brown, treas; J. S. McMaster, supt; Cotton and Woolen Dress Goods, Etc; 750 looms; steam; dye; Jno. Farnam & Co, N. Y. and Phila, s. agts; J. B. Morgan, buyer.
- BERNSTEIN, KAUFFMANN & Co;** 1101 Race St; Map B; Sq. 45; Cloak Trimmings.
- BESWICK, SAMUEL;** (formerly Beswick (**W** & Kay); Fairmount Spinning Mills; 25th and Callowhill Sts; Map A; Sq. 44; Wool and Merino Weaving and Knitting Yarns; 7 sets; steam; dye; sell direct; Sam'l Beswick, buyer.
- BILGER, NICHOLAS;** 113 Bread St; Map (**C** B); Sq. 45; Webbing; 12 looms; steam; Carl H. Finck, s. agt.; N. Bilger, buyer.
- BINDER & ELLIS;** Allegheny Ave. (**C & S** and C St; Curtains and Upholstery Goods; 50 looms; steam; sell direct; firm, buyers.
- BINGS, JOHN;** 2013 Ella St; Moresque (**W** Yarns; 168 twisting spindles; 8 knitting machines; steam.
- BINNS' PATENT BAND CO. (Incorp);** (**S**) \$50,000; \$30,000 paid up; L. Binns; 5th and Berks Sts; Map C; Sq. 61; L. Binns, pres, treas, and agt; C. H. Binns, sec; Spindle Bands, Brilliant Yarns, Novelty Yarns of all descriptions and Tinsels; steam; sell direct; L. Binns, buyer.
- BINZ, CONRAD, CARPET WORKS;** A. W. & (**W** B); Binz; 2426 N. 3rd St; Map C; Sq. 61; Rag Carpets; 20 looms; hand power; sell direct; A. W. Binz, buyer.
- BINZ, F;** Allegheny Ave. and A St; (**W**) Granite, Ingrain and Jute Carpets; 38 looms; steam; sell direct.
- BIRKHEAD SPINNING CO.** *Out of business.*
- BISWANGER, E. Est;** Wishart and Emer (**W** and Sts; Map C; Sq. 76; Ingrains; 30 looms; steam; sell direct.
- BITZER, CHAS;** 2512 E. Dauphin St; Map (**K** C); Sq. 54; Carlinn Jackets; 6 knitting machines; hand power; sell direct; Chas. Bitzer, buyer.
- BLACK, JOS. & SONS CO.** *See York, Pa.*
- BLAKELEY, JNO. & SON;** 1142 Sophia (**C & W** St, 1085 Germantown Ave; Map A; Sq. 61; Cotton and Woolen Waste; 5 machines; steam; sell direct; firm, buyer.
- BLANKENBURG, RUDOLPH & Co;** (Ine.); (**C**) Olympia Mills; 24th and Ellsworth Sts; Map B; Sq. 36; Down Quilts and Cotton Comforts.
- BLICKLE, FRED'K;** 2053 Coral St; Map C; (**K**) Sq. 62; Hosiery; 6 knitting machines; hand power; sell direct; F. Blickele, buyer.
- BLICKLE'S, JNO, SONS;** 2428 Orkney St; (**K**) Map C; Sq. 61; Knit Jackets, Skirts, Leg-gins, Vests and Sweaters; 40 knitting machines; steam and hand; sell direct; Jno. Blickele, buyer.
- BLOOD, JOHN, & Co;** Seventh and Sou- (**K**) cerset Sts; Map A; Sq. 61; Cotton, Seam- less and Cut Hosiery; 750 knitting machines; steam; dye; N. Y. office, 349 Broad- way.
- BLOOD, J. & BRO;** Allegheny and Tren- (**K**) ton Aves; Map C; Sq. 63; Ribbed Under- wear; 50 body machines; 25 sleeves and 75 sewing machines; steam; Wm. Iselin & Co, N. Y. s. agts, and sell direct; Edward Blood, buyer. (Buy yarn.)
- BOCHMAN, F. A. & Co;** Second and (**W**) Cambria Sts; Map A; Sq. 61; Dress Goods;
- 300 looms; steam; Oelbermann, Dommer- ich & Co, N. Y. s. agts; C. H. Landen- berger, buyer.
- Boggs, Jno;** 2561 Trenton Ave; Map A; (**W**) Sq. 62; Ingrain; 60 looms; steam; H. B. Claffin & Co, N. Y. s. agts; John Boggs, buyer.
- Boggs, THOS. & SONS;** Model Carpet (**W**) Mills, 2nd St, and Allegheny Ave; Map A; Sq. 70; Sam'l R. and Geo. W. Boggs, supts; Ingrain Carpets; 83 looms; steam; sell direct; Thos. Boggs, buyer.
- BOWER & KAUFMANN;** N. E. cor. 5th and (**K**) Columbia Ave; Map C; Sq. 53; Seamless and Full Fashioned Men's, Women's and Children's Hosiery; 300 knitting machines; steam; N. Y. office, 917 N. Y. Life Bldg; sell direct; firm, buyers.
- BOWER, W. H;** 912 Fairmount Ave; Map (**D**) A; Sq. 53; Cotton Yarn; steam; W. H. Bower, buyer.
- BOYLE, A. & BRO;** 2529 Fairhill St; (**K**) Seamless and Ribbed Hosiery; 200 knit- ting machines; steam; sell direct; firm, buyers.
- BRADBURY BROS;** Dalkeith Mills; (**C & W**) Bristol St, near Germantown Ave; Nice- town; Map A; Sq. 84; William Bradbury; supt; Cotton and Worsted Goods; 164 looms; steam; dye; Jas. Scott & Sons, 73 Leonard St, N. Y. s. agts; William Brad- bury, buyer.
- BRADFORD MILLS;** John & Jas. Dobson; (**W**) Stenton and Godfrey Sts; Germantown; not shown on map; F. Clough, supt; Lus- tre Coatings, Mohair and Alpaca Brilliant- ines and Genapped, Worsted and Mohair Yarns; 6 combs; 250 looms; 52 1/2 worsted spindles; steam; dye; office, 26 N. Front St; salesroom, 99 Franklin St, N. Y.
- BRAMWELL, SAM'L;** 5329 Pulaski Ave. (**K**) Germantown; Map D; Sq. 90; Knit Goods; 8 knitters; 9 ribbers; 2 loopers; 1 steam press; sell direct.
- BRAUN, Mrs. H.** (formerly Lorenz (**K**) Braun); 206 Poplar St; Cardigan Jackets and Woolen Hosiery; 2 knitting machines; hand power.
- BREADY, E. K;** Girard Worsted MILL; (**W**) Howard and Huntingdon Sts; Dress Goods and Novelties; 58 looms; steam; sell direct; E. K. Bready, buyer. (Buy worsted yarns.)
- BREHM & STEHLE;** Allegheny Dye (**D**) Works; Trenton and Allegheny Ave; Map E; Sq. 71; Charles Stehle, supt. and buyer; Cotton, Woolen and Mixed Yarns, Jute and Twines; steam.
- BRIGHTON MILLS;** C. F. Sloane, propr; (**W**) cor. Howard and Palmer Sts; Map C; Sq. 54; Men's Wear Worsteds and Ladies' Dress Goods; 24 broad looms; steam; sell direct; C. F. Sloan, buyer.
- BROMLEY BROS' CARPET CO;** York and (**W**) Jasper Sts; Map C; Sq. 62 and Indiana Ave., below Front St.; Map A; Sq. 69; \$250,000; T. Bromley, pres; John H. Bromley, Jr., treas.; Thos. Bromley, Jr., vice-pres. and supt.; Smyrna and Axminster Rugs and Carpets and Woolen and Worsted Yarns (English System); 7 sets; 1 comb; 375 looms; steam; dye; sell direct; T. Brom- ley, Jr, buyer. (Mill at Indiana Ave.; Geo. Bowers, supt.; Smyrna Rugs and Carpets; 60 looms; steam.)
- BROMLEY, JAS. & GEO. D;** Albion Car- (**W**) pet Mills; Adams and Jasper Sts; Map C; Sq. 62; Ingrain Carpets; 8 sets; 12 broad looms; 128 yard wide looms; steam; dye; sell direct; firm, buyers. (Buy worsted and woolen carpet yarns.)
- BROMLEY, JOHN, & SONS;** Lehigh Ave. (**W**) below Front St; Map C; Sq. 62; Smyrna Rugs and Carpets; 13 sets; 1000 power looms; steam; dye; T. R. Shorrif & Co, N. Y. s. agts; also sell direct; firm, buyers.

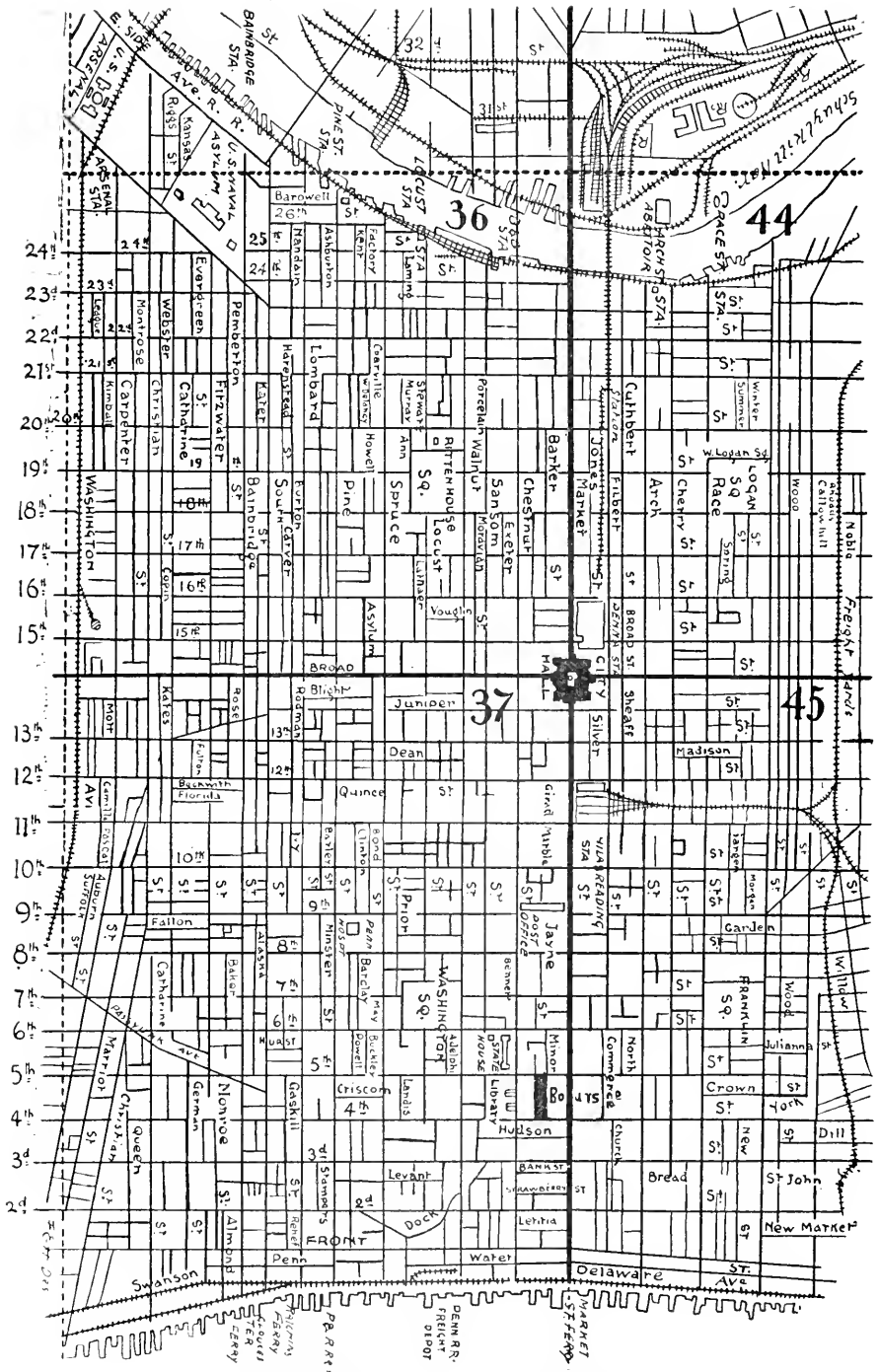

PHILADELPHIA. MAP B—DOWN TOWN BUSINESS SECTION.

## PAXTON &amp; O'NEILL'S

 $\frac{3}{4}$  Automatic Knitter

For all kinds and Gauges of Seamless  
Hosiery,

Has Automatic Tension, and when desired, Fashioning Device  
for Ladies' Hose and Double Sole attachment.

Has the preference wherever used over  $\frac{7}{8}$  and Full Automatic.

*Because*

- It makes as much or more goods and better goods.
- Costs less for repairs.
- Gives less trouble to fixers.

Range on  $\frac{1}{2}$  Hose from the coarsest to 220 needles.

## PAXTON &amp; O'NEILL,

127 Broad Street, Philadelphia.

Cylinders and Dials for all size machines.

BROMLEY, JOSEPH H.; See *Lehigh Mfg. Co.*

BROMLEY MFG. Co; Lehigh Ave, below (C) Front St; Map C; Sq. 62; W. H. Bromley, mgr; Tapestry and Chenille Curtains and Lace Curtains, and Table Covers; 800 looms; steam; dye; sell direct; firm, buyer.

BROOKE, M. E.; Ottoman Mill; 1729 Philip (C) St; Louis H. Foster, supt; Tidies, Searls, Covers, Turkish Towels, Terry Cloths; 10 looms; steam; sell direct; Louis H. Foster, buyer. (Buy cotton yarns, 8-20)

BROOKS, GEO. & SON; Oriental Mills; 55th (S) St. and Wyalusing Ave; West Phila; Map A; Sq. 41; \$300,000; Henry Brooks, pres.; Robt. Morrell, treas.; Upholstery Goods; 165 looms; steam; dye; sell direct; Henry Brooks, buyer; N. Y. office, 133 5th Ave.

BROOKSIDE WORSTED MILLS; R. H. (W) Shen, prop.; 2636-2640 Marscher St.; Map C; Sq. 62; Worsted and Woolen Goods; 22 broad looms; steam; Boers-neck, Broescl & Co., N. Y., dept. Oscar Hoffstadt, s. agts.

BROPHY'S, T. SONS; Kensington Dye (D) Works; Jasper St, above Clearfield St; Map A; Sq. 71; Dyers of Cotton, Woolen, Worsted, Linen, Jute and Mixed Yarns and Cotton Warps; capacity, 15,000 lbs. yarn, 10,000 lbs. warps per day; steam; firm, buyers

BROWN, C. M. & CO; Coaquanock Mills; (W) 6th St. and Haverford Ave; West Phila.; Woolen Goods; 6 sets; 120 looms; steam; dye; Jacob Wendell & Co, N. Y., s. agts. C. M. Brown, buyer.

BROWN-ABERLE CO, THE; Palathorp (K) and Huntingdon Sts; Map A; Sq. 62; \$500,000; Gustave Rumpf, pres.; Thomas E. Brown, treas; Henry Brown, supt; Full Fashioned Hosiery; 900 knitting machines; 50 sewing and 60 seaming machines; steam; dye; Harrington & War-

ing, 71 Franklin St, N. Y., s. agts; Henry Brown, buyer.

BROWN & HUNT; Allegheny Ave, be- (K) tween Front and 2d Sts; Full Fashioned Laced and Fleece Hosiery; 600 knitting machines; steam; Wesendonck, Lorenz & Co., N. Y., s. agts. (Buy 10s to 60s cotton yarns.)

BROWN KNITTING CO; 2nd St. & Alle- (K) gheny Ave; \$100,000; Thos. E. Brown, pres; W. Park Moore, treas; Thos. E. Brown, supt; Fashioned Hosiery; 500 knitting machines; Harrington & Waring, s. agts; Thos. E. Brown, buyer.

BROWN, THOMAS E. & SON; Radmoor (K) Mill; Hazzard and Sepviva Sts; Thos. E. Brown, Jr., supt.; Ladies', Men's and Misses' Fashioned and Seamless Cotton Hosiery; 200 knitting machines; steam; Harrington & Waring, N. Y., s. agts. (Buy combed Egyptian yarns, all numbers.)

BROWN, WILSON H. & BRO. See Leicester Mills Co.

BRIFY, FRANK G; 1731 Gillingham (C & W) St; Frankford; Map E; Sq. 80; Job Beaming; 4 frames; steam.

BRUNER, FRANCIS A; Unity and Lei (S & L) per Sts., Frankford; Upholstery Goods, Curtains, Table Covers and Linen Towels; 68 looms; steam; D. R. Stirratt, 416 Broadway, s. agt; F. A. Bruner, buyer. (Buy 2 and 3 ply cotton yarns.)

BUCK, THOS. & CO; Jasper and York Sts; (K) Cut and Seamless Cotton Hosiery; 500 knitting machines; 25 sewing machines; steam; C. G. Culin, N. Y., s. agt., and sell direct; Thos. Buck, buyer.

BUCKHALTER, FRED; Front and Clear- (D) field Sts; Map A; Sq. 69; Yarn Dyers; steam; dye.

BUCKHALTER, FRED; Howard and Clear- (K) field Sts; Map C; Sq. 54; Ladies' Fine

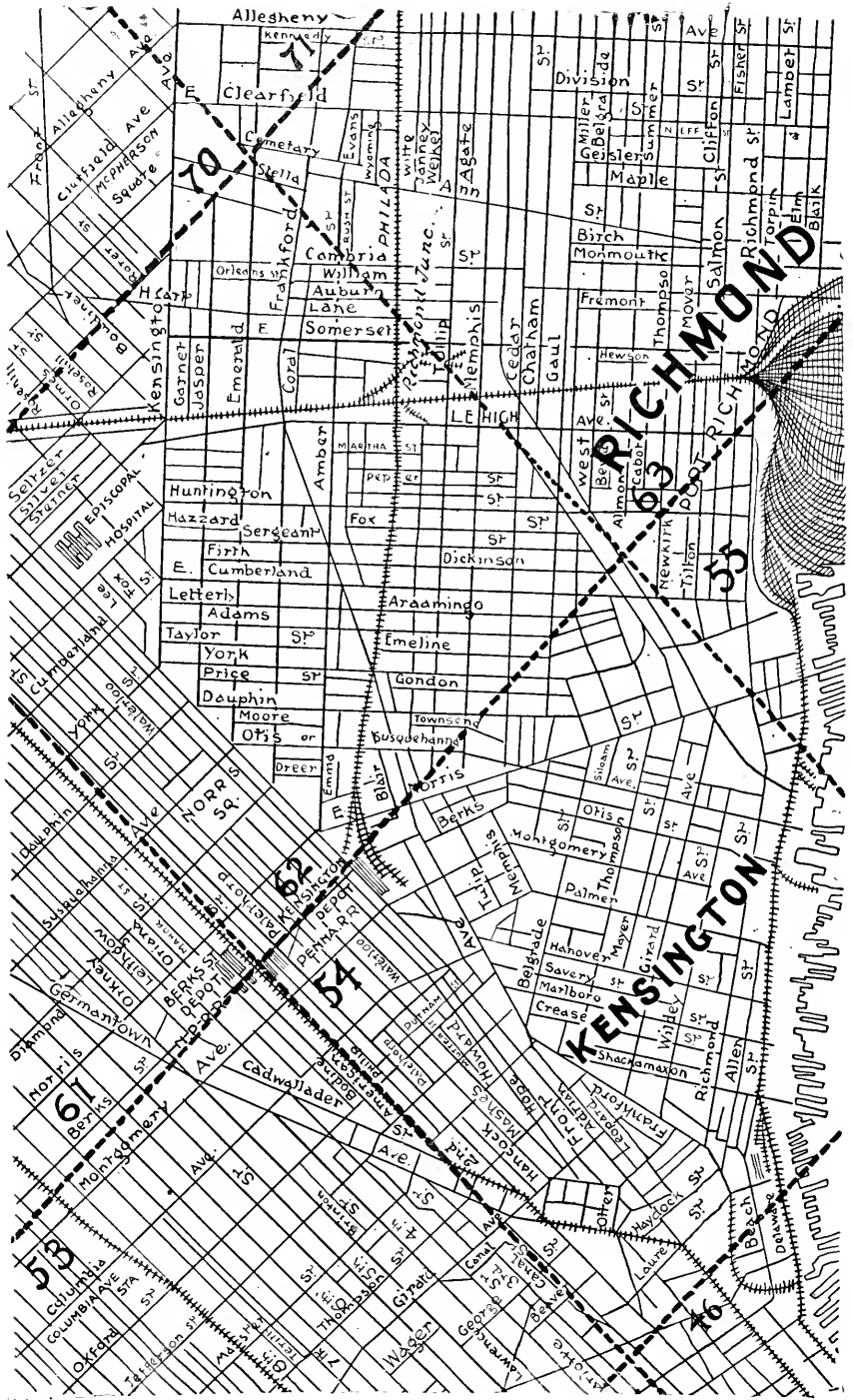

PHILADELPHIA. MAP C—KENSINGTON AND RICHMOND DISTRICT.



- Seamless Hosiery; 50 knitting machines; steam; Wesendonck, Lorenz & Co, 411 Leonard St., N. Y., s. agts, also sell direct; Fred Buckhalter, buyer.
- BUNTING, SAM'L B.**; Persian Mills; 1202-14 (W) S. 12th St.; Map A; Sq. 29; Jno. W. Bunting, supt; Cottonades, Worsteds and Cassimeres; 2 sets; 60 looms; steam; dye; F. Victor & Achelis, and Wm. Iselin & Co, N. Y., s. agts, and sell direct; J. W. and Sam'l B. Bunting, buyers.
- BURNS, WM. H.**; (successor to Bromiley (D & Burns); 4060 Orchard St.; Frankford; Map E; Sq. 80; steam; dye.
- BURTON, ANDREW**; Penn. St. and Bel. (D) field Ave, Germantown; Map D; Sq. 91; Dyer Cotton and Woolen Yarns; steam; Andrew Burton, buyer.
- BUTTERWORTH, GEO.**; Excelsior (C, W & S) Beaming Mills; Mascher and Somerset Sts; Map C; Sq. 62; Crawshaw Wolfenden, supt; Cotton, Silk, Worsted, Woolen and Mohair Warps; 11 beaming frames; steam; sell direct; Geo. Butterworth, buyer.
- CALEDONIA CARPET MILL**; Alexander (W) Crowe, prop.; 2212 Noble St.; J. H. C. Wright, supt.; Ingrain Carpets and Yarns; 8 sets; 145 looms; steam; dye; sell direct; Alex. Crowe, Jr., buyer. (See also Caledonia Worsted Mill.)
- CALEDONIA WORSTED MILL**; Alex. (W) Crowe, prop.; N. W. 21st St. and Shamokin Sts.; Mr. Kennedy, mgr.; Worsted Yarns; 4 sets; 16,000 spindles; 8 combs; steam; sell direct; Mr. Kennedy, buyer. (See also Caledonia Carpet Mill.)
- CALLAGHAN, ALBERT**; Trustee; Angora (W) Mills; Angora Sta, P. W. & B. RR.; Map A; Sq. 41; Wool Cheviots; 14 sets; 250 looms; steam and water; dye; Albert Callaghan, buyer.
- CAMERON, A. J. & Co**; American and (W) Dauphin Sts; Map C; Sq. 62; Worsted Tops; 6 combs.
- CAMERON WORSTED CO, THE A. J.**; Emer. (W) ald and Westmorland Sts.; Map E; Sq. 71; A. J. Cameron, pres; Jas. T. Smith, secy, and treas; Worsted Yarns; (English System); 3,300 spindles; A. J. Cameron & Co., Phila., Boston and Chicago, s. agts.
- CAMPBELL, J. A. & Bro.**; Crompton (W) Mill; Manayunk; Map F; Sq. 73; Plush Goods, Silk, Cotton and Mohair, for Upholstery and Dress purposes; Table Covers; 85 looms; steam; dye; Young & Armitage, 1200 Chestnut St., Phila. s. agts; firm, buyers.
- CAMPBELL, JOHN J.**; 3rd and Cumber. (E) land Sts; Map C; Sq. 61; Finisher of Worsted and Woolen Goods.
- CANFIELD MFG. CO, LTD.**; n. w. cor. (C) Franklin and Vine Sts; Steam and Water Packing; (buy cotton, flax and linen yarns and flax roving); 32 braiding machines.
- CAREY, WM.**; Baltic Carpet Mill; 1351 (W) Columbia Ave; Map C; Sq. 54; Ingrain and Rag Carpets; 10 hand looms; sell direct; Wm. Carey, buyer.
- CARRUTH, JOHN G. & Co**; Endurance (W) Mills; Roschill and Indiana Ave; Map C; Sq. 62; Cassimeres, Flannels, Dress Goods, Shirts; 600 looms; steam. Jno. G. Carruth, & Co, 61 Leonard St., N. Y., s. agts; Jno. G. Carruth, buyer.
- CARSON, ROBT**; Franklin Carpet Mills; (W) E. Huntingdon, cor. Trenton Ave; Map A; Sq. 62; Ingrain; 78 power looms; steam; sell direct; Robt. Carson, buyer.
- CARSON, JOHN W.**; Red Star Dye (D) Works; Glenwood Ave.; Cotton and Woolen Yarn; steam.
- CARSON, GEO.**; Hancock, above Lehigh (W) Ave; Map A; Sq. 61; Ingrains; 40 yd.
- wide looms; 10 broad looms; steam; sell direct. (Buy carpet yarns.)
- CASE MFG. Co, Ltd.**; 213 N. Broad St.; Map (S) B; Sq. 45; H. C. Case, pres; Geo. C. Keim, sec. and treas; Rug Fringes and Upholstery Trimmings; 15 hand and 12 power looms; sell direct.
- CAVES, THOS. & SONS**; Keystone Carpet (W) Mills; 3rd and Huntingdon; Map A; Sq. 61; Wm. J. Caves, supt; Ingrain Carpets; 100 looms; steam; dye; sell direct; Thos. Caves, buyer.
- CENTURY TAPESTRY MILLS**; 2739 Fairhill (C) Ave; Albert Mitchell, mgr; Upholstery Piece Goods, Curtains, Etc; 28 looms; sell direct.
- CHARLOTTE DYE WORKS**; Edward Kager. (D) mann, prop.; 1210-1220 Orianna St.; (above Girard Ave); Dye Fine Cotton and Woolen Yarns; Fast Black a Specialty; steam.
- CHAMBERS, JOSEPH**; 2114 E. William St.; (W) Ingrain; 14 looms.
- CHAIRWOOD HOSIERY Co**; Cor. Lehigh (K) Ave. and Mascher St; Map C; Sq. 62; \$100,000; Leonard M. Addis, treas; Marion Strain, supt; High Grade, Full Fashioned, Cotton Hosiery; 46 heads; steam; Harrington & Waring, 71 Franklin St., N. Y., s. agts.
- CHARTER HOSIERY MFG. Co**; 226 Ash. (K) mead St; Germantown; Map D; Sq. 91; \$20,000; John S. Palmer, pres; J. F. Farrell, treas; John B. Barker, supt; Plain, Ribbed, Fancy and Cut Hosiery; 450 knitting machines; steam; sell direct; J. F. Farrell, buyer.
- CHESTER, E. G., DYEING Co**; Trenton and (D) Susquehanna Aves; Map C; Sq. 62; Dyers of Fast Black and Colors on Hosiery and Yarn; steam.
- CHESTER, E. G. HOSIERY Co**; Trenton (K) and Susquehanna Aves; Map C; Sq. 62; Howard G. Chester, supt; Ladies' and Men's Cotton Hosiery; 100 knitting machines; steam; dye; sell direct. (Buy yarn.)
- CHRIST BROS MFG. Co**; (formerly Row. (C) land & Christ; 1303 Buttonwood St; Dress Trimmings, Brads, Coris, Traveler Exercisers, Chest Developers, Jump Ropes and Braided Fish Lines; 250 Braiders; sell direct; J. H. Christ, buyer.
- CLAPP, WM.**; Howard & Berks Sts; E. (W) R. Clapp, supt; Commission Spinner of Carpet Yarns; 3 sets; steam.
- CLARK & BARKER**; Pastorius and Os. (K) ceola Sts.; Germantown; Map D; Sq. 91; John Barker, mgr.; Men's Salt Hose, Ladies' and Children's Full Seamless and Cut Hose; 25 full seamless machines; 20 round heads; steam; dye; sell direct; E. Clark, buyer. (Buy Nos. 12-14 16-20-40 cotton yarns.)
- CLARKE, WM.**; Waverly Mills; Cedar (C) St, above Margarity, Frankford; Map E; Sq. 80; Turkey Red Damask; 134 looms; steam; dye; Wilhelmberg & Bissett, N. Y., s. agts. (Buy 3 and 4 ply cotton yarns.)
- CLELAND, ROBT. & SONS**; 1101-1113 (W) Waverly St; Map B; Sq. 37; Cloth, Dun- dee, Matting, Rags and Art Carpets; 62 looms; steam; sell direct; J. H. C. Cleland, buyer.
- CLEGG, WM. & SONS**; Manayunk; Cassi. (W) mers, Cotton Worsteds; Doeskins; 45 looms; steam and water; sell direct, and W. Stursberg, Schell & Co, N. Y., s. agts.
- CLOUGH, JOS., SONS & Co**; Fairmount (D) Dye Works; 618 No. 24th St; Map A; Sq. 44; Dyers and Bleachers of Cotton Yarns and Warps, Beaming and Dressing; steam; dye; J. Clough, buyer.
- COATES, WM. MRS.**; Frankford Ave. and (W) Mill St; Frankford; Map E; Sq. 80; Shoddy; 3 cards; 4 pickers; 2 garnett machines; steam; sell direct; Mrs. Wm. Coates, buyer.



- COCHRANE, CHAS. P.; Devon Mills; (**W**) Howard and Lehigh Aves; Map A; Sq. 61; Persian, Ingrain and Aubusson Stair Carpets; 66 looms; steam; sell direct; C. P. Cochrane, buyer.
- COLD SPRING BLEACHING AND FINISHING WORKS. *See Yardley, Pa.*
- COLLARD, A.; 256 Ashmead St; German. (**K**) town; Map D; Sq. 91; Gloves and Mittens; 16 knitting machines; hand power; H. Chawner, N. Y. s. agt.
- COLLINS, LAWRENCE; Riverdale Carpet (**W**) Mills; Howard and Turner Sts; Ingrain and Jute Carpets; 15 looms; steam; sell direct.
- COLLINS & AIKMAN Co; Manayunk; Map (**W**) F; Sq. 73; C. M. Aikman, pres; W. G. Collins, sec. and treas; Frank H. Roatch, supt; Flushes; 100 looms; steam; dye; C. M. Aikman & Co, N. Y. s. agts.
- COLUMBIA SPINNING CO; Haines Street (**C**) near Stenton Ave.; Germantown; \$300,000; W. J. Robertson, gen'l mgr.; Cotton Hosiery and Combed Egyptian Yarns; 3500 spindles; steam; sell direct.
- CONNELLY, JAMES, & SONS; Quaker City (**C**) Mills; 17th and Dickinson St; Map A; Sq. 28; Checks, Ginghams and Cheviots; 180 looms; steam; sell direct; the firm, buyers.
- CONSOLIDATED HOSIERY & FINISHING CO; Hancock and Somerset Sts; Map A; Sq. 61; Fine Gauge Goods, Fast Black a Specialty; 80 machines; Sellers & Steele, N. Y. and Pittsburg and Harry Fallen, Phila. s. agts.
- COPE & Co.; Tonawanda Mill. *Out of business.*
- COPE KNITTING MILLS; E. M. Cope & Co; (**K**) Germantown; Map D; Sq. 91; Men's, Ladies' and Children's Underwear; steam; Critten, Cliff & Co, N. Y. s. agts; J. B. Cope, buyer.
- COTTER & O'KEEFE; Adams and Ruan (**D**) Sts; Frankford; Map E; Sq. 80; Cotton Yarn Dyers; steam.
- COULTER & LOWRY; Excelsior Finishing (**F**) Works; 203-57 No. 22d St; J. C. Lowry, pres; H. H. Lowry, treas; Finishers of Cotton Goods. (Also see Greensboro, N. C.)
- COX, GEO. S. & BRO; Cambria and (**C**) Ormes Sts; Map C; Sq. 70; Hair Cloth; 145 looms; steam; sell direct.
- CREDENTIAL MFG. CO; Huntington St. (**K**) and Kensington Ave; Map C; Sq. 62; Cotton, Seamless and Cut Hosiery; 300 knitting machines; steam; sell direct; John J. McDevitt, buyer.
- CROSSINGHAM, JAMES II; Crossingham (**K**) Knitting Mills; 245 Ashmead St, Germantown; Map D; Sq. 91; Wool, Cotton and Merino Ladies', Misses' and Gents' Underwear; 58 knitting machines; steam; dye; Critten, Cliff & Co, 48 Leonard St, N. Y. s. agts.
- CROWN KNITTING CO; Hancock and (**K**) Turner Sts; Map D; Sq. 91; Wm. Thudrain, supt; Hosiery; steam; sell direct; M. Tandler, buyer.
- CULBERTSON, JOHN, & SONS; Man. (**C** & **W**) hattan Mill; 23rd and Hamilton, N. W. cor. 3rd and Cumberland Sts; Map A; Sq. 44; William Wilson, supt; Cotton, Woolen and Worsted Dress Goods; 600 looms; steam; dye; Jas. W. Cooke & Co, N. Y. and Phila. s. agts; the firm, buyers.
- CUMBERLAND FINISHING WORKS. *See Moore & Co.*
- CURRIE, DANIEL; Norris Carpet Mills; (**W**) Lawrence and Lehigh Aves; Map A; Sq. 61; Samuel Currie, supt; Ingrain Carpets; 40 looms; steam; sell direct; Daniel Currie, buyer.
- DALE, WM. HENRY; Gillingham St; Frank. **C** ford; Map E; Sq. 80; Damask and Lap Robes; 18 looms; steam; sell direct. (Buy cotton yarn.)
- DALLAS, ROBT; Oxford and Josephine (**C**) Sts; Map E; Sq. 80; Ginghams, Linseys, Cheviots, and Cottonades; 74 looms; Frederick Victor & Achelis, s. agts.
- DALZELL, ISAAC; 249 Collom St; Ger. (**K**) mantown; Hosiery; 150 knitting and 24 sewing machines; steam; sell direct; I. Dalzell, buyer.
- DANBY & FETTEROLF; Wayne June. (**W**) tion; W. Chalk, supt; Wilton Rugs and Carpets; 24 looms; steam; sell direct; F. Danby, buyer. (Buy 12s, 13s, 16s carpet yarns.)
- DAVENPORT, JOHN; N. E. cor. Hancock (**W**) and Somerset Sts; Map A; Sq. 61; Tapestry and Velvet Carpets; 25 looms; steam; sell direct; John Davenport, buyer.
- DAVIDSON & BROOKE; Orianna Bleach (**B**) Works; 2560 No. 3rd St; Map A; Sq. 61; Bleacher Yarns, Hosiery, Tapes, Turkish Towels, etc; steam.
- DAVIES TEXTILE CO. (formerly Thomas (**C**) Davies); Orthodox and Large Sts.; Frankford; Map E; Sq. 80; \$150,000; C. H. Outerbridge, pres. and treas.; Thos. Davies, sec. and mgr.; Novelties in Upholstery Fabrics, Damasks, etc; 60 looms; steam; sell direct. (Buy carpet yarns.)
- DAVIS, W. S. Missouri Mills; Main St; (**W**) Manayunk; Map F; Sq. 73; Martin A. Kehoe, supt; Carpet and Rug Yarns; 6 sets; 1008 woolen spindles; water; sell direct.
- DAVIS & HANCOCK; 4933 Richmond St; (**C**) Bridesburg; not shown on map; Joseph C. Davis, supt; Curtains and Table Covers; 22 Jacquard looms; steam; sell direct; Joseph Davis, buyer.
- DAWSON, J. & E; Huntington Ave. and (**C**) Huntington St; Warp Dressers and Beavers.
- DAWSON, THOS. & Co; Amber, near (**D**) Somerset St; Map C; Sq. 62; Dyer, Woolen and Cotton Yarns; steam; Thos. Dawson, buyer.
- DEARNLEY, JOHN II; 8th and Somerset (**W**) Sts; Map A; Sq. 61; Worsted and Woolen Yarns; (English System); 4 sets; 8 combs; 5000 worsted spindles; steam; sell direct; J. H. Dearnley, buyer.
- DELAWARE KNITTING MILLS. *See Chas. E. Kremer.*
- DELPH SPINNING CO, THE; Clearfield, (**C**) Roschill and C Sts; Cotton Yarn; 13,248 spindles; Jas. E. Mitchell & Co, 122 Chestnut St, Phila. s. agts.
- DELVOOD MILL; Samuel McKeaige, (**W**) proprietor; 2720 Hancock St; Map C; Sq. 61; Cotton Worsteds; 14 looms; steam; sell direct.
- DE LYTE TAPESTRY MILLS; J. New. (**C** & **S**) ton and H. Bennett, pros; 2634 Mascher St.; Tapestry Curtains and Table Covers; 6 looms; steam; sell direct. (Buy 20s, 5/2, 8/2, 9/4 yarns.)
- DERK, JOSEPH & Co; Davenport Mills; (**C**) S. E. cor. Mascher and York Sts; Map C; Sq. 62; Cross Stripe Curtains; 16 looms; steam; Ryan & McGahan and Howard D. Thomas, s. agts; Mr. Smith, buyer.
- DEVELON'S, THOS. SONS; Victoria Carpet (**W**) Mill; Hancock St and Lehigh Ave; Map A; Sq. 61; All Grades of Ingrain Carpets; 120 looms; steam; Tho. Develon, Jr., buyer; N. Y. office, 706 Hartford Bldg.
- DEVILS, CHAS; Hilton & Kensington. (**C** & **W**) ton Ave; Cotton and Woolen Waste and Shoddy; 1 picker; 1 willow; 1 duster; steam; sell direct; Chas. Devlin, buyer.
- DEXTER DYING & CARBONIZING WORKS; (**D**) E. A. Townsend & Co; Main St. and Shurs Lane, Manayunk; Map A; Sq. 70; Dyeing and Carbonizing.



PHILADELPHIA. MAP E—FRANKFORD DISTRICT.

- DICKEL, HENRY & SON;** 2012-2024 E. Ariz. (W) ona St; Map C; Sq. 62; Carpets; 50 looms; steam; sell direct; W. A. Dickel, buyer.
- DICKEY & MCMASTER;** 2nd and Hunting. (W) don; Map A; Sq. 61; Damask and Venetian Stair Carpets, Granite, Ingrains and Granite Art Squares; 60 looms; steam; dye; sell direct; N. Dickey, buyer.
- DIEZ, JOHN G. & Co;** 2466-08 Hope St, near (W) Front and York Ave; Map C; Sq. 62; List and Rag Carpets; 16 looms; sell direct; John G. Diez, buyer.
- DILLER, E. J.;** Columbia Dye Works; 167 (D) Columbia Ave; Map C; Sq. 54; Dyers Yarns; steam.
- DINGLEY MFG. Co.** *Out of business.*
- DIXON, WM. F.;** 102 Leverington Ave; (C & W) Manyunk; Map F; Sq. 73; Thomas J. Dixon, supt; Cotton and Woolen Waste for Wiping and Packing; 1 willow; 2 pul- lers; steam.
- DOAK'S, JNO. SONS;** Front, above Hunt. (D) ington St; Map A; Sq. 61; Fancy Cotton and Woolen Dyers; steam.
- DOAK, JAS. JR. & Co;** Standard Worsted (W) Mills; Trenton Ave, Norris and Blair Sts; May C; Sq. 62; Worsted Yarns; (English System); 6300 spindles; 7 combs; steam; sell direct; Jas. Doak, Jr, buyer.
- DOBSON, J.;** Falls of Schuylkill Mill; (W) Map F; Sq. 66; John Robinson, supt; Cloaking and Overcoating; 9 sets; 75 broad looms; steam; dye; office, 26 N. Front St; sell direct and Boessneck, Broesel & Co, N. Y. s. agts; John Dobson, buyer.
- DOBSON, JOHN;** Rock Hill Mill; West (W) Manyunk; Map F; Sq. 72; Woolen Yarns; 6 sets; steam.
- DOBSON, JOHN;** Falls of Schuylkill; Map (W) F; Sq. 66; Jno Robinson, supt; Blankets, Overcoatings, Etc; 30 sets; 260 looms; steam; dye; sell direct and Boessneck, Broesel & Co., s. agts; Jno. Robinson, buyer.
- DOBSON, J. & J.;** Falls of Schuylkill Car. (W) pet Mills; Map F; Sq. 66; H. N. Bentley, mgr; Brussels, Wilton and Velvet Carpets, Worsted and Mohair Yarns; 24 sets; 8 combs; 600 looms; steam; dye; Carpets, Plushes, T. J. Jeffries, 27 Bank St; s. agt; offices, 26 N. Front St, Phila; 72-74 Greene St, N. Y.; Thos. Barry, buyer.
- DOERR, PHILIP, & SONS;** 5th St. and Col. (W) umbia Ave; Map C; Sq. 53; Ingrain Car- pets; 74 looms; steam; sell direct. (Buy yarns.)
- DONLON, JOHN II.;** Palethrope and (W) Somersset; Sts; Ingrain, Art Squares; 5 looms; steam.
- DONNELLY, A. J. & Co.** *Out of business.*
- DORNAN BROS.;** Monitor Carpet Mill; (W) Oxford, Howard and Mascher Sts; Map C; Sq. 54; Rugs and Extra Super Ingrains and 3 plys; 13 sets; 160 looms; steam; dye; sell direct; Dornan Bros, buyers; N. Y. office, Constable Bldg; Chicago, 262 Wa- bash Ave.
- DOVER MILL;** W. H. Lees, agt; Jasper (C & W) and Huntingdon Sts; Map C; Sq. 62; Cotton, Woolen and Linen Goods; 140 looms; steam; Cathm & Co., 216 Church St., N. Y., s. agts; Wm. H. Lees, buyer.
- DRAGON DYE WORKS;** W. C. Foulds, prop. (D) and mgr.; Allegheny Ave. and Amber St.; Dye Wool, Worsted and Cotton Yarn; steam.
- DREIFUS, JACOB S.;** 833 Arch St; Hand Knit Zephyr Goods.
- DUNLAP, JAS. CARPET CO.;** 55th St. and (W) Lancaster Ave; Jas. Dunlap, pres. and treas; Ingrains; 159 looms; sell direct.
- DUNLAP, JOHN, & SON.;** No. 11th and (W) Cambria Sts; Map A; Sq. 61; Ingrain Car- pets; 100 looms; steam; dye; sell direct; J. Dunlap, Jr, Yarn buyer.
- DYER, WM. E.;** Hancock and Edward Sts. (K) Map A; Sq. 61; Ladies' Cotton Hose and Half Hose; 22 knitting machines; sell di- rect.
- EASTLAKE MFG. CO.;** 4060 Orchard (C & S) St; Frankford; Map E; Sq. 80; \$50,000; Henry Brooke, pres; James Bromiley, treas. and supt; Furniture Gimp; 34 looms; steam; sell direct; James Brom- iley, buyer.
- EAVENSON & LEVERING, (formerly (W) Patebell & Eavenson);** Naudain St; Map B; Sq. 36; Scouring, Burring and Carboniz- ing Wool.
- ECONOMY HOSIERY CO.;** Oxford and Han- (K) cock Sts.; Ladies' Cotton Hosiery; 19 knit- ting machines; sell direct.
- EDGEWATER PRINT WORKS.;** (Pr. D & F) Frankford Ave. & Mill St; Frankford; Map E; Sq. 71; Dyers and Finishers; steam.
- EDWARD MILLS, THE.** *Out of business.*
- EICHLER, A. & Co.;** Vienna Dye Works; (D) 1736 Mascher St; Map C; Sq. 54; Cotton and Woolen Yarns; steam.
- ELDER, JAS.;** Germantown Cordage (C) Works; (successor to Jas. Elder & Son); 230 Coulter St; Germantown; Rope and Cordage in Cotton; steam; sell direct.
- ELECTRIC DYE WORKS.;** 3942 Frank. (D & B) ford Ave.; Charles E. Winch and Frank W. Janney; Cotton and Silkline Dyeing and Bleaching; steam.
- ELK KNITTING MILLS CO.;** (successors (K) to Julius Hirsch); N. W. Cor. American and Diamond Sts; Map C; Sq. 61; \$50,000; Julius Hirsch, pres; Harry Nelke, treas; Ladies', Misses and Children's Ribbed Underwear; 40 knitting machines; steam.
- ELLIS, D. W. C. & Co.;** Ripka Mills; Man- (C) ayunk; Map F; Sq. 73; Chas. Schlotterer, supt; Principally Cotton Dress Goods; 200 looms; water; sell direct; salesroom, 244 Chestnut St; D. W. C. Ellis, buyer.
- ELLIS, W. G. & Co.;** Star Seamless Hos. (K) iery Mill; 415-419 Vine St; Map A; Sq. 45; Augustus Slack, supt; Plain, Rib, Cut and Seamless Hosiery and Bicycle Hose; 300 knitting machines; steam; dye; sell di- rect; Geo. E. Ellis, buyer.
- EMBLEY, WM. & BRO.;** Washington Mills; (W) Emerald and Adams Sts; Map C; Sq. 62; Wool and Merino Yarns; 8 sets; 5,500 spindles; steam; dye; sell direct; firm, buyers.
- ERBEN, HARDING, & Co.;** Taony & Fair- (W) mount Worsted Mills; 2416 Spring Garden St; Map A; Sq. 44; Worsted, Woolen, Me- rino Yarns (English and French sys- tems) and Processed Lambs' Wool; 25 combs; steam; dye; sell direct; office, 26 So. 3rd St; firm, buyers.
- ERSKINE, ALEXANDER.;** 4th and Somer- (W) set Sts; Shawls, Blankets, etc; 20 looms; steam; sell direct; Alex. Erskine, buyer.
- EVANS & STONELY KNITTING MILLS.;** 5120 (K) Wakefield St; Germantown; Map D; Sq. 92; J. Welsh, supt.; Jackets, Sweaters and Caps; 50 knitting machines; steam; sell direct; F. Stonely, buyer. (Buy cotton, wool, worsted and silkatine yarns.)
- FALK, O. N. & Co.;** 1907 N. Ninth St.; (C) Fancy Curtains; 8 looms; sell direct; O. N. Falk, buyer.
- FARRELL, HENRY B.;** Howard and Berks (W) Sts; Map C; Sq. 54; Fine Wool Spun Cotton Yarns; 328 spindles; 4 sets; steam; sell direct; H. B. Farrell, buyer.
- FELD & Co. (LTD.);** Novelty Knitting (K) Mills; N. E. cor. 5th and Market Sts.; (Isaac Feld and Harry Baerbach); Sweaters, Golf Hose, Athletic Goods and Bathing Suits; 10 knitting machines; hand power; N. Y. office, 112 Stanton St.

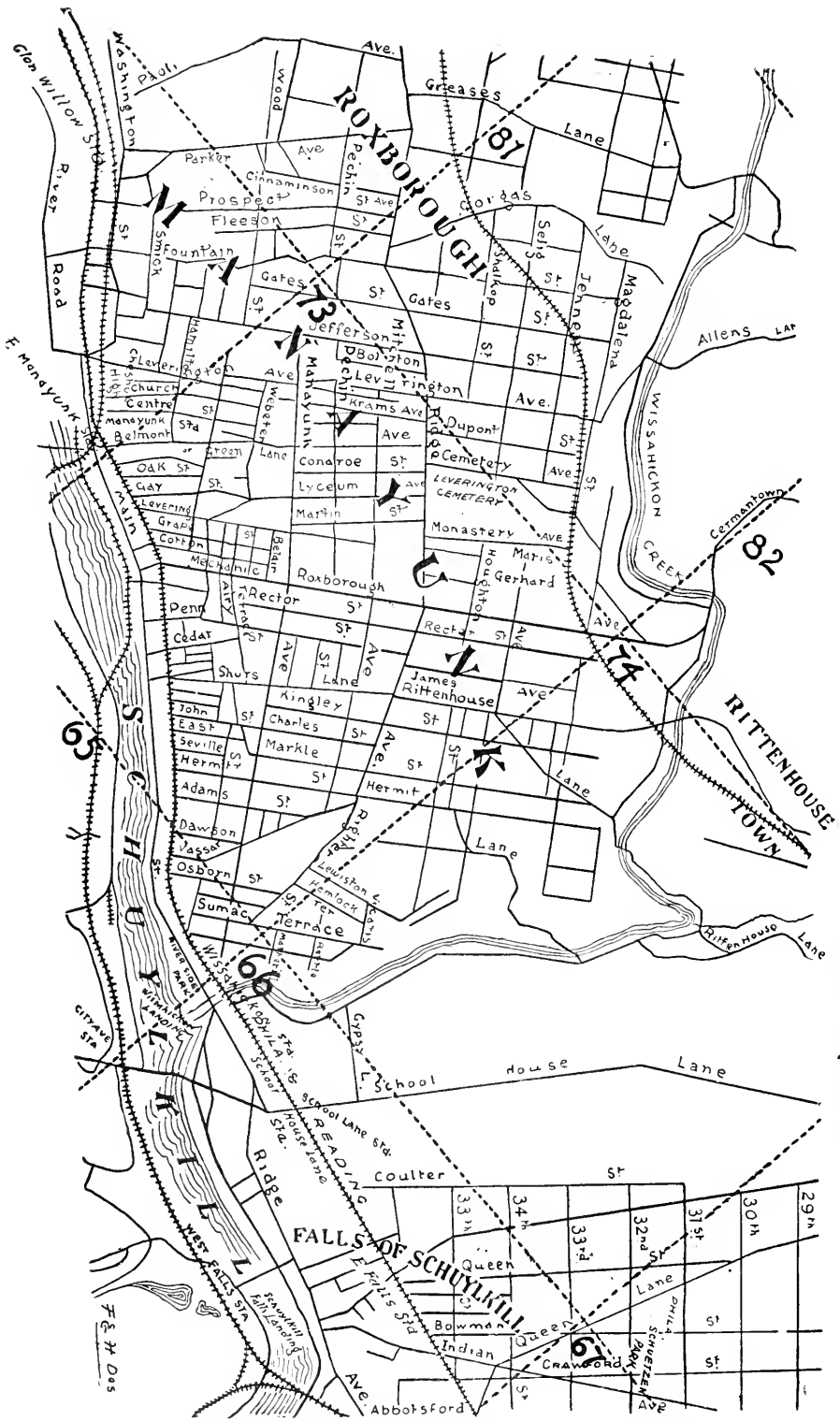

PHILADELPHIA. MAP F—MANAYUNK AND FALLS OF SCHUYLKILL.

- FERGUSON, S. B., & Co;** American and (K) Snsquehanna Aves; Map C; Sq. 61; Cotton Hosiery; 110 knitting machines; steam; C. H. Swearingen, Pittsburg; Hinchman, Veitch & Co, N. Y., s. agts.
- FERN ROCK WOOLEN MILLS;** Trenton (W) Ave. and Wishart Sts.; Herman Broesel, pres.; Curt A. Loewel, vice-pres.; M. L. Kahn, treas.; Oscar Hoffstadt, sec. and gen'l mgr.; Cloakings, Overcoatings and Woolen Dress Goods; 233 looms; steam; Boessnick, Broesel & Co., N. Y., s. agts.
- FIDELITY FINISHING WORKS;** Wm. C. (F) Melcher, prop. and mgr.; Turner and Mascher Sts.; Finishers of all kinds of Fabrics.
- FINK, WM;** 1909 E. Dauphin St; Map C; (C) Sq. 62; Coverlets; 6 looms, hand power; sell direct; Wm. Fink, buyer.
- FIRTH & FOSTER CO;** Providence (D & F) Dyeing and Finishing Works; Emerald and York Sts; Map C; Sq. 62; Albert Foster, gen'l mgr; Dyers and Finishers, Yarns and Piece Goods; steam; dye; office 546 Bourse Bldg; Phila.; Silk Exchange, N. Y.; firm, buyers.
- FITLER, EDWIN H., CO;** Philadelphia (J) Cordage Works; 22 N. Delaware Ave. and Bridesburg; \$1,500,000; Wm. W. Fitler, pres. and treas.; Binder Twine and Cordage; sell direct.
- FLANAGAN, A., & BRO;** Freeland Mills; (W) Walnut Lane; Manayunk; Map F; Sq. 73; F. Flanagan, supt; Carpet and Backing Yarns; 11 sets; steam; sell direct.
- FLAVELL, GEO. W., & BRO;** 1005 Spring Gar- (K) den St; Map A; Sq. 45; Elastic Bandages and Hosiery; 9 knitting machines; hand power; sell direct; Geo. W. Flavell, buyer.
- FLAVELL BROS;** 50-52-54 Church Lane; (K) Germantown; Underwear; 60 knitting and 61 sewing machines; steam; bleach; Muir & Malone, N. Y., s. agts; firm, buyers.
- FLEISHER, S. B., & B. W.;** (Inc.) Star Braid (W) Works; \$700,000; 25th and Hamilton Sts; Map A; Sq. 44; S. B. Fleisher, pres; E. A. Fleisher, treas; Braid and Worsted and Woolen Yarns, (English System); and Braids; 15 sets; 10 combs; 9,500 spindles; 620 braiders; steam; dye; sell direct; 28 So. 6th St; Phila.; Boston; N. Y.; St. Louis and Chicago; firm buyer.
- FLEMING, CHAS. H.;** Silver Star Dye (D) Wks.; Collins and Westmoreland Sts.; Cotton Hosiery Dyer.
- FLING'S, JOSEPH, SONS;** Germantown (W) Yarn Mill; Wister St; Germantown; Map D; Sq. 92; Yarns; 4 sets; steam; dye; sell direct; Wm. J. Fling, buyer.
- FLING, THOS. W., & BROS.** *Out of business.*
- FOLWELL BRO. & Co. (Inc.);** Colling. (W) wood Mills; 3rd and Cambria Sts; Map A; Sq. 69; \$1,150,000; N. T. Folwell, pres; J. S. Potter, treas; Mitchell Stead, supt; Woolen and Worsted Goods for Men's and Women's Wear; 6 combs; 400 looms; steam; dye; sell direct; salesrooms, 625 Chestnut St, Phila.; 487 Broadway, N. Y.; president generally buys.
- FORD, W. A. R.;** Frankford Carpet (W & J) Mills; Tacony St. and Penn. R.R.; Frankford; Map E; Sq. 80; Carpets and Jute Yarns, Woolen Yarns; 12 sets; 1625 spin dies; 50 looms; steam; sell direct; W. H. Sheely, 133 Fifth Ave., N. Y., s. agt.; partners, buyers.
- FORREST, JOHN;** American Yarn (P & D) Print Works; 134 No. 22nd St; Map A; Sq. 44; Printer of Cotton, Woolen, Silk and Worsted Yarns and Bleach Yarns; steam.
- FOSTER, J. R., & SONS;** Second and (D & F) Clearfield Sts; Map A; Sq. 78; Yarns, also Cotton, Woolen and Worsted Goods; steam; firm, buy.
- FOSTER, W. A.;** Globe Finishing Works; (F) 153-45 Ruan St; 968 Frankford; Finishers Damask, Etc; steam.
- FOULK, R. T.;** Coral and Adams Sts; (W) Map C; Sq. 62; Ingrain and Art Squares; 15 looms; steam; sell direct.
- FOWLER NET & TWINE CO.;** 200 Market (C) St.; Samuel S. Fowler, supt.; Fish Nettings; 3 looms; gas engine; sell direct.
- FRANKFORD CO-OPERATIVE MFG. CO.;** (C) Orthodox and Horrocks Sts; Frankford; Map E; Sq. 80; \$20,000; Cotton Damask; 104 looms; steam; Whitman and Phelps, N. Y., s. agts; Geo. F. Thompson, buyer.
- FRANKFORD HOSIERY CO.;** Adams St.; (K) Frankford; Map E; Sq. 80; \$100,000; William J. Fling, pres. and treas.; Urban Udall, supt.; Cotton, Seamless and Cut Hosiery; 8 sets; 300 knitting machines; steam; dye; Sutton & Co, 55 Leonard St, N. Y., s. agts; Urban Udall, buyer. (Buy yarns.)
- FRANKFORD LINEN FINISHING CO.** *Out of business.*
- FRANKFORD WASTE CO;** Orchard & (C & W) Vandyke Sts; Frankford; Map E; Sq. 80; Cotton and Woolen Waste; 2 Pickers; 3 Willows; 1 garnet; 1 shredder; steam; sell direct; firm, buyers.
- FRANKLIN BLEACHING AND FINISH (B1 & F) ING WORKS, Ltd;** 70th St. near Haverford Road; Chas. A. Rice, pres; John McGill, Jr, sec. and treas; Cotton and Linen Piece Goods.
- FRANKLIN HOSIERY CO.;** 968 Franklin St; (K) Henry Stien, supt; Misses' Ribbed Hose and Half Hose; 20 knitting machines; 5 loopers; 18 rib machines; steam; sell direct.
- FRANKLINVILLE DYE WORKS Co., Ltd.;** (D) Lawrence, Luzerne and 5th Sts; Robert Meyer, pres; Wm. C. Foulds, treas; Fast Black and Color Dyeing.
- FREELAND MFG. Co;** Freeland Ave. and (W) Walnut Lane, Manayunk; Map F; Sq. 73; Harry Taylor, supt; Flannels, Blankets and Linings; 11 sets; 70 looms; steam; sell direct.
- FRENCH, HUGH, & SON;** 3rd and Cum- (W) berland Sts; Map A; Sq. 61; Waste, Flocks and Shoddy; 3 pullers; 1 willow; 1 picker; steam; sell direct; Hugh French & Son, buyers.
- FRETZ, SAMUEL S. Co.;** 20-22-24 N. 4th St.; (S) Samuel S. Fretz, pres.; Israel W. Gross, supt.; Umbrella Silks; 60 looms; steam and electric; sell direct; S. S. Fretz and I. W. Gross, buyers.
- FRIEDBERGER MFG. Co.;** 18th St, (C W & S) and Fisher's Lane; Germantown; Map D; Sq. 92; \$375,000; S. Friedberger, pres. and gen. mgr.; Max N. Aaron, sales agent; Silk, Cotton and Worsted Laces; Silk and Cotton Braids; 100 looms; 600 braiders; steam; bleach and dye; sell direct; S. Friedberger, buyer.
- FROMUTH, C.;** 2125 Hope St; Map A; Sq. (W) 62; Rag Carpets; 20 looms; hand power; sell direct; C. Fromuth, buyer.
- GALASHIAN, JOHN;** 2512 Callowhill St; Map (C) A; Sq. 44; Madras, Cheviot, Cotton and Woolen Flannels, Cotton Dress Goods; 60 looms; steam; sell direct; John Galashian, buyer.
- GALBRAITH, M. J.;** estate of; Somerset (W) Carpet Mill; 2718 Hancock St; Map A; Sq. 61; James Galbraith, mgr; Ingrains; 15 looms; steam; sell direct.
- GARDNER, JOHN, & SON;** Wellington (W) Mills; Madison St. and Kensington Ave; Map C; Sq. 71; Carpet Yarn; 500 spindles; 4 sets; steam; sell direct; firm, buyers.
- GARDNER, W. A.;** Somerset and Bondi- (W) not Sts; Map C; Sq. 62; Shawls and Dress Goods; 24 looms; steam; E. R. Masters & Co, N. Y., s. agts; W. A. Gardner, buyer.
- GAY'S, JOHN, SONS (INCOP.);** Park Car- (W) pet Mills; Howard and Norris Sts; Map C; Sq. 62; \$300,000; Jas. H. Gay, pres; John

- H. Gay, sec. and treas; Thos. S. Gay, supt; Ingrains; 201 looms; steam; dye; sell direct.
- GEBAUER, JULIUS A; 4155 Frankford (W Ave); Cottons and Worsteds for Men's Wear; 33 looms; steam; James Talcott, N. Y., s. agt.
- GENEVA KNITTING MILLS; Thos. Kent (K Mfg. Co; Station M, Holmesburg Junction; A. J. Martin, mgr. and buyer; Eider-down, Underwear, Athletic Goods and Bathing Suits; 45 knitting and 75 sewing machines; 3 nappers; 3 riplers; steam; sell direct.
- GERMAN-AMERICAN HOSIERY CO; Cambria and Oram Sts; \$100,000; Robt. Meyer, pres; Hugo Huettig, treas. and gen. mgr; High Grade, Full Fashioned Ladies' and Children's Hosiery; 35 knitting machines; steam; Harrington & Waring, 71 Franklin St, N. Y., s. agts.
- GERMANTOWN LACE WORKS; F. A. By. (C ram, prop; Lena St, above Church Lane; Germantown; Map D; Sq. 91; Lace Edgings, for Underwear; 15 machines; steam; Geo. W. Chapin, 229 Church St., Phila., s. agt.; F. A. Byram, buyer.
- GERMANTOWN SPINNING CO; High St. and (C R RR; Germantown; Map D; Sq. 91; \$150,000; Frank E. Patterson, pres; Oscar W. Wood, treas; Hosiery Yarns; 17,000 mule spindles; steam; sell direct; O. W. Wood, buyer.
- GETTY & SPRATT; 244 East Huntingdon (W St; Map C; Sq. 63; Ingrains; 19 power looms; steam; sell direct; firm, buyers.
- GILL, THOS. & SON; York and Waterloo (C Sts; Map C; Sq. 62; Warp Dressing and Beaming.
- GILMOUR, R. & A. J.; 2631 No. 3rd St; Map (F A; Sq. 61; Finishers Cotton and Woolen Goods; steam; dye.
- GIRARD WORSTED MILL. *See E. K. Bready.*
- GLASGOW MILL; Huntington & Jasper (C Sts; Map C; Sq. 62; John H. Meyer and Otto Gaetze; A. H. Burnham, supt; Fine Madras and Fine Shirting Novelties; 300 looms; steam.
- GODSHALK, E. H. CO, THE; 24th and (C & K Hamilton Sts; Map A; Sq. 44; \$250,000; E. H. Godshalk, pres; C. A. Godshalk, treas; Knit Goods and Chenille and Tapestry Curtains; 200 knitting machines; 100 looms; steam; The E. H. Godshalk Co, N. Y., Chicago, Boston & Phila., s. agts; E. H. Godshalk, buyer.
- GOODMAN, LOEB & CO; 428-438 N. 13th St; (S Dress and Millinery Trimmings; 60 looms; 500 braiders; 36 knitters; steam; sell direct; I. H. Goodman, buyer.
- GORMAN, T. C; 1731 Gillingham St; Frank-(C Ford; Map E; Sq. 80; Damasks; 8 looms; steam; sell direct. (Buy cotton yarns.)
- GOULD, C. & J.; 2507 Potter St; Misses' (K Extra Fine Ribbed Hose and Men's Fine Cotton and Cashmere Half Hose; 100 knitting machines; steam. (Also *See Bethlehem.*)
- GRANGE, WILLIAM G; 9th and Dauphin (C Sts; Map A; Sq. 61; Upholstery Goods; 24 looms; steam; Ryan & McGahan, N. Y., and H. D. Thomas & Co, Seattle, s. agts; Wm. Grange, buyer. (Buy yarns.)
- GRANT, HENRY, & SON; 3d and Somerset (W Sts; Map A; Sq. 61; Fine Merino and Woolen Yarns; 4 sets; 2735 spindles; steam; sell direct; Henry Grant, buyer.
- GRAVES, THOS; Shirland Knitting Mills; (K Wakefield and Brimhurst Sts; Germantown; Map D; Sq. 91; Cardigan Jackets, Sweaters and Fancy Knit Goods; 40 knitting machines; steam; sell direct; Thos. Graves, buyer.
- GRAVES, THOS. W; Perseverance Mill; (K 4947 Wakefield St; Germantown; Map D; Sq. 92; J. W. Graves, supt; Cotton Seamless Hosiery; 200 knitting machines; 25 sewing machines; steam; sell direct; Thos. W. Graves, buyer.
- GRAVES BROS; Standard Mills; Jas-(W per and Huntingdon Sts; Map C; Sq. 62; A. W. Graves, supt; Mixed Goods; 120 looms; steam; sell direct; A. W. Graves, buyer; N. Y. office, Eagle Building, 55 Franklin St.
- GREENWOOD, JOHN; Emerald and Hunt-(D ington Sts; Map C; Sq. 62; J. Fred'k. Greenwood, supt. and buyer; Dyer, Cotton and Woolen Carpet Yarns; steam.
- GREENWOOD, R. & BAULT; Globe (B1 & D Dye & Bleach Works; Oxford and Worth Sts; Frankford; Map E; Sq. 80; Cotton Chain Warps and Skein Yarn Dyers, Bleachers and Mercerizers; steam; dye and bleach; office, 140 Chestnut St; Greenwood & Bault, buyers.
- GREER, BENJ. W; Bellevue Worsted (C & W Mills; Germantown; Map D; Sq. 92; Worsted and Cotton Goods; 250 looms; steam; dye; sell direct, and agts; Benj. W. Greer, buyer. (Buy cotton and worsted yarns.)
- GREER, DAVID; 9th and Dauphin Sts; (W Map A; Sq. 61; Worsteds and Woolens; 160 looms; steam; sell direct; 89 Leonard St, N. Y.; David Greer, buyer. (Buys yarns.)
- GREER, JOSEPH; Emerald Mills; Oxford (W and Worth Sts; Map E; Sq. 80; Worsteds; 200 looms; steam; dye; B. M. Ewing & Co, N. Y., s. agts; Jos. Greer, buyer.
- GRIFFON COMPANY; Frankford; \$75,000; (W Ernest F. Greiff, pres; Rudolph Kraft, treas; Ladies' Fine Dress Goods; 112 looms; steam; dye; Max Riedel, s. agt; Rudolph Kraft, 112 Spring St, N. Y., buyer.
- GRISWOLD WORSTED CO. (Ltd); 322 Chestnut St. *See Darby, Pa.*
- GROVER, JOHN D. & SON; Somerset and (W Tulip Sts.; Scourers Wool and Hair (Also Importers and Dealers).
- GROVER, WM. F. & CO; N. E. cor. Turner (K & Maseher Sts; Map C; Sq. 54; Ladies' and Children's Hosiery; 50 knitting machines; steam; sell direct; Wm. F. Grover, buyer.
- HACKENBURG, WM. B. & CO; (Incor. (S porated); 1341-1347 Noble St; Map B; Sq. 45; \$100,000; W. B. Hackenberg, pres; David A. Price, treas; Chas. A. Bohem, supt; Sewing and Machine Silks; steam; sales-rooms, 516 Market St, Phila., 156 and 158 Market St, Chicago, 4 W. 3rd St, Cincinnati; 422 W. Baltimore, St, Baltimore.
- HAGIH, J. C. & CO; Columbia Finishing (F Works; 1729 Gillingham St; Frankford; Piece Finishing.
- HALFORD, JOSEPH, & SONS; 125 Herman (K St; Germantown; Map D; Sq. 91; Ribbed Hosiery; 40 knitting machines; steam; sell direct; Jos. Halford & Sons, buyers.
- HALL, L. C, JR, & CO; 535 Arch St; (K Map B; Sq. 45; Silk and Worsted Gloves, Mittens and Wristlets; 100 knitting machines; steam; John S. Tapscott & Co; N. Y., and Balto, s. agts. and sell direct.
- HALL CARPET CO; THE, JAMES, Lehigh (W Ave. and Front St; Ingrain Carpets; 30 looms; steam; sell direct; E. W. Har-rison, buyer.
- HALTEMAN, M. L.; Oxford and Josephine (C Sts.; Frankford; Fine Grade Madras, Chambray, Fancy Dress Goods, Etc.; (use principally single yarn, 3-50s warps; single 20-40 filling and 2/40-2/90 mercerized filling; 50 looms; steam.
- HALTON'S, THOS. SONS; Allegheny Ave. (C and C St; T. H. Halton, mgr; Cotton Damask Centre Table Covers; 30 looms;



- steam; E. Ransohoff & Son, Phila., s. agts, and sell direct; T. H. Halton, buyer.
- HAMAN, F. D.**; 2304 Waterloo St; Map C; (**W**) Sq. 62; Rugs and Table Covers; 14 looms; steam; sell direct; F. D. Haman, buyer.
- HAMILL & CO.**; Church Lane and Lena (**W**) St; Germantown; R. B. Curtis, supt; Wool and Merino Yarns; 5500 spindles; 6 sets; steam; sell direct.
- HAMILTON, JOHN, & SON.**; Montgomery (**W**) Carpet Mills; Lehigh Ave. and Howard St.; Map A; Sq. 61; Ingrain Carpets; 75 looms; steam; sell direct; John Hamilton, buyer.
- HANFEN, JOHN E. & CO.**; Marlborough (**K**) Mills; Savery and Thompson Sts, Kensington; Map C; Sq. 54; Elderdown Cloth, Ladies' Donet, Lawn and Elder Sacks and Robes, Athletic Goods and Bathing Suits; 90 knitting machines; 160 sewing machines; steam; dye; Spielmann & Co, N. Y., for cloth; Sutton & Co, N. Y., s. agts. for underwear; John E. Hanfen, buyer. (Buy 20s cotton and mohair yarns.)
- HAROLD HOSIERY CO.**; 2d St. and Alle- (**K**) gheny Ave; Map A; Sq. 69; Full Fashioned Hosiery; 300 knitting machines; steam; sell direct.
- HARRIS, T. A. & CO.**; Continental Dye (**D**) Works; 147 West Thompson St; Map C; Sq. 64; Dyers Cotton and Woolen Yarns, Knit Goods and Hosiery; steam; office, 240 Chestnut St, Phila.
- HARRISON & MALLATRATT.**; 314 & 320 Ar- (**K**) mat St; Germantown; Map D; Sq. 91; John T. Harrison, supt; Seamless and Cut Hosiery; 200 knitting and 30 sewing machines; steam; sell direct; Jos. Mallatratt, buyer.
- HARVEY, D. & SON.**; Janney, below Alle- (**F**) gheny Ave; Map C; Sq. 63; Finishers; steam; sell direct; firm, buyers.
- HASLAM & QUERNER.**; Rainbow Dye (**D**) Works; Lehigh Ave. and Howard St.; Map A. Sq. 61; Worsted and Woolen Yarn Dyers; steam; J. G. Haslam, buyer.
- HEINEMANN, HARRY J. & CO.**; 2042-46 (**P**-r) Palethorp St; Hosiery Printing; steam.
- HELLMER, M.**; 311 Poplar St; Map C; Sq. (**K**) 53; Seamless Hosiery and Cartigan Jackets; 6 knitting machines; hand power; sell direct; M. Hellmer, buyer.
- HELLWIG, ALBERT, & CO.**; 9th and But- (**D**) tonwood Sts; Map B; Sq. 45; Skein Silk Dyers; steam.
- HENDERSON, WM.**; Mascher and Oxford (**W**) Sts; Map C; Sq. 54; Extra Super Ingrain Carpets; 50 power looms; steam; sell direct; Wm. Henderson, buyer. (Buy yarns.)
- HENRY, H. S.**; West End Mills; 64th and (**W**) South Sts; not shown on maps; Samuel Rigby, supt; Flannels and Cassimeres; 14 sets; 225 looms; steam; dye; Treat & Converse, N. Y., s. agts; H. S. Henry, buyer.
- HENRY, THOS. & SONS.**; Tioga Mills; (**W**) Trenton Ave. and Tioga St; Map E; Sq. 71; Hosiery Yarns, 6 to 30s. Carpet Yarns, 50 yds. to 130 yds.; 19,000 spindles; steam; sell direct; firm, buyers.
- HENSEL, COLLADAY CO.**; Franklin and (**S**) Vine Sts; Map B; Sq. 45; \$150,000; Geo. S. Hensel, pres; Wm. W. Colladay, treas;
- S. B. Colladay sec; H. Haase, supt; Dress and Cloak Trimmings; 175 looms; 20 knitting machines; steam; sell direct; G. S. Hensel, buyer; N. Y. office, 396 Broadway.
- HENSEL SILK MFG. CO.**; 639 No. Broad St; (**S**) Map A; Sq. 45; \$25,000; Jos. L. Caven, pres.; J. R. Hunsberger, treas.; Upholstery and Drapery Trimmings; 35 looms; D. Robt. Shirratt, N. Y.; A. L. Faxon, Boston and The Allison Co, s. agts.
- HERBST, ALBERT & CO.**; Emerald Wor- (**W**) sted Yarn Mills; S. W. Cor. Allegheny Ave. & Emerald St; Map C; Sq. 71; Worsted Yarns 16s to 30s; (Bradford system); 1000 spindles; steam; sell direct.
- HETRICK, WM. A. & BRO.**; 304-306 Bel- (**K**) grade St.; Colton Hosiery; 20 knitting machines; steam; Wm. A. Hetrick, buyer.
- HEWETT, C. G.**; Unity and Leiper Sts; (**C**) Frankford; Map E; Sq. 80; Damasks; 20 looms; steam; sell direct and Catlin & Co., N. Y., s. agts. (Buys 3 ply cotton yarns.)
- HEY, DAVID.**; Germantown; Shoddy (**W**) and Carpet Yarns; 6 sets; 3 pickers; water and steam.
- HEY, RICHARD, & SON.**; Progress Mill; (**W**) Manayunk; Map F; Sq. 73; Robert H. Hey, supt; Blankets, Linings, etc; 17 sets; 100 looms; steam; dye; Fredk. Victor & Achels, 76 Leonard St, N. Y., s. agts.
- HEYMER, EDWARD.**; York and Mascher (**W**) Sts; Map C; Sq. 62; Ingrains; 15 looms; steam; traveling agts; also sell direct; Edward Heymer, buyer.
- HILL, WM.**; cor. Mascher and York (**C**) Sts; Map C; Sq. 62; Wm. Hill, gen. mgr.; Tapestry Curtains, Covers and Piece Goods; 8 looms; sell direct.
- HIRSCHMAN, A.**; (formerly Jos. Hoff. (**W**) man); 1843 E. Hazard St; Rag Carpets; 8 hand looms; sell direct.
- HIRST & ROGER.**; Allegheny and Kens- (**W**) ington Aves; Map C; Sq. 71; Mr. Roger, supt; Tapestry and Velvet Carpet; 60 looms; steam; sell direct; R. Hirst, buyer. (Buy cotton yarns.)
- HITCHON W. W.**; Thorps Lane and (**C** & **W**) 16th St; (P. O. Station R); Map D; Sq. 92; Shoddies and Cotton and Woolen Waste; 1 set; steam; sell direct; W. W. Hitchon, buyer.
- HODSON, JOHN M.**; Mallison Rope (**C** & **J**) Walk; Markle and Cresson Sts; Manayunk; Map A; Sq. 73; Walter M. Hodson, supt; Banding, Rope and Twine, Single and Double Loop Bands; steam; sell direct; J. M. Hodson, buyer.
- HOFFMAN-CORR MFG. CO.**; Lion Mill; (**C** & **J**) (formerly Hoffman, Corkran & Co.); 415 Market St; Map B; Sq. 45; Cordage, Twines, Hammocks, Yarn, Tow, Nets, Oakum and Cotton Waste; 60 looms; steam; sell direct; Mr. Hoffman, buyer; salesrooms, 415 Market St, Phila; 107 Duane St, N. Y.; Madison and Market Sts., Chicago. (Also mill at 1842 Germantown Road; 30 looms; steam.)
- HOFFMAN MFG. CO.**; Howard and Palmer (**C**) Sts.; Tapes, Webbing and Bindings, Specialty Medium and Superfine Tapes.
- HOGG, CHAS. & BRO.**; Diamond Knitting (**K**) Mill; 2351-2353 Reece St; Map C; Sq. 61; Jerseys and Women's Waists; 9 knit-

## THOMAS JOHNSON Fairhill Printing House,

Printer of Bands, Labels, etc., for the  
Hosiery Trade.

2600 N. FIFTH STREET, PHILADELPHIA.

References: The Leading Jobbing Houses and Hosiery Manufacturers in the country.

- ting machines; steam; J. P. Jenkins, N. Y., s. agt; C. Hogg, buyer.
- HOLDEN, EDWIN, & Co;** Margaret and (C) Ditman Sts; Frankford; Map E; Sq. 80; Damask Table Covers, Derby Cloth and Curtains; also Tapes; 58 looms; steam; finish; sell direct; J. W. Herbert, buyer. (Buy 2 ply cotton yarns.)
- HOLDSWORTH & ARTHUR;** 1822 Cadwalla. (C) der St; Map C; Sq. 53; Tapes,tries, Curtains, Table and Couch Covers; 16 looms; W. E. Rosenthal, N. Y., s. agt; Mr. Arthur, buyer.
- HOLDSWORTH, FRED'K;** 5th and Berks (S) Sts; Frankford; Map C; Sq. 61; Upholstery and Curtain Fabrics; 12 looms; steam; W. E. Rosenthal, 458 Broadway, N. Y., s. agt; H. Newton, buyer.
- HOLMES, ARCHIBALD & SON;** Tuxedo (W) Carpet Mills; Alleghany Ave. and A St.; Cotton and Wool Ingrains; 56 Ingrain looms; steam; sell direct; A. Holmes, buyer. (Buy 12s to 20s cotton yarns.)
- HOLMES, HENRY, & SONS;** Sherman Carpet Mills; Station E; Trenton Ave. and Auburn St; Map A; Sq. 70; John Reeve, supt; Ingrains and Art Squares; 105 looms; steam; dye; Blake Bros, 108 Worth St, N. Y., s. agts; Henry R. Holmes, buyer.
- HOLMES, JNO. G.;** 107 So. 8th St.; Surgical (K) Elastic Hosiery, Abdominal Supporters, etc. (Buy spun silk, floss silk and cotton, from 40 to 100.)
- HOLT, JOHN P.;** Perseverance Mills; (W) Main St, below Shur's Lane, Manayunk; Map F; Sq. 73; L. H. Sheerer, supt; Double Reeled Carpet, Woolen and Merino Yarns; 6 sets; steam; dye; W. J. Holt, salesman; J. P. Holt, buyer.
- HOOLEY, B. & SON;** 439 N. Broad St; Map (S) B; Sq. 44; Throwsters; 10,000 spindles; steam; sell direct; G. L. Hooley, buyer.
- HOOPER SONS MFG. Co.;** Imperial (C & S) Braiding Mills; 426-428 Market St.; \$75,000; Wm. E. Hooper, pres.; Robert P. Hooper, treas.; Herbert Holt, supt.; Braided Goods; 600 bradders; electricity; sell direct; Robert P. Hooper, buyer.
- HORROCKS & BRO;** Adams and Unity (D & F) Sts; Frankford; Map E; Sq. 79; Dyers, Bleachers, Finishers of Cotton Piece Goods, Warps and Skein Yarns; steam.
- HORTSMANN, WM. H. Co.;** Fifth and Cherry (S) Sts; Map B; Sq. 45; Walter Horstmann, pres.; S. Eckert, vice-president; H. Freund, treas.; H. McManus, supt; Yarns, Dress and Upholstery Trimmings, Etc. 200 looms; steam; sell direct; salesroom, cor. Grand and Broadway, N. Y.; Mr. Eckert, buyer.
- HOYLE, HARRISON & KAYE;** Front and (S) Indiana Ave; Station E; Map A; Sq. 62; Upholstery Goods, Chenille and Tapestry Table Covers and Curtains; 370 looms; steam; dye; C. B. Young & Co. Hartford Bldg, 17th and Broadway, N. Y., s. agts; Andrew Kaye, buyer.
- HUF, CHAS. P.;** 1126 Sophia St; (formerly (K) Jos. Hilbert); Knit Jackets; 3 knitting machines.
- HUGHES MFG. Co, THE;** (success. (C & D) sors to G. W. Hughes & Co.); Trenton Ave. and Clearfield St; Map C; Sq. 63; \$20,000; R. S. Irwin, pres; G. W. Hughes, treas. and gen. mgr; Soft and Polished Threads; also Dyers and Bleachers Cotton Yarns; steam.
- HULTON DYEING & FINISHING Co., (D & F) THE;** 2712 Jasper St.; \$400,000; Dyeing and Finishing Woolen and Worsted Cloth; steam.
- HUSTON, THOS. & Co;** Globe Carpet (W) Mills; Trenton Ave. and Dauphin St; Map A; Sq. 70; Ingrains; 62 looms; steam; sell direct; Thos. Huston & Co, buyer.
- HYGIENIC FLEECE-LINED UNDERWEAR (K) Co. (Inc.)** 2415-2437 Howard St; 2414-2436 Hope St; \$200,000; James Dobson, pres; Thos. F. Barry, treas; E. P. McCabe, vice-pres. and mgr; Underwear, Hosiery, Athletic Knit Goods, Jersey Cloth, and Knit Bathing Suits, etc; 410 knitting machines; 200 sewing machines; steam; sell direct; N. Y. office, 98 N. Y. Life Bldg; also offices at Boston, Chicago, Detroit, San Francisco and Denver; Ed. P. McCabe, buyer. (Buy cotton, wool, worsted and silk yarn.)
- HYNDMAN & MOORE Co;** Columbia Mill; (S) Coral and Adams Sts; \$50,000; Station K; Map C; Sq. 62; John Moore, pres; William Hyndman, treas; Tapestry and Chenille Curtains and Covers; 100 looms; steam; Felix J. McCosker, N. Y. and Boston, s. agt; also sell direct; John Moore, buyer.
- LIFFE, JOHN;** 112 No. Front St; Map C; (D) Sq. 54; Skein Silk Dyer; steam.
- IMPERIAL WOOLEN Co;** (formerly Blair. (W) lyc and Eagle Mills of Seville, Schofield, Sons & Co., Manayunk); Map E; Sq. 73; Jas. Dobson, pres; J. Dobson Schofield, treas. and buyer; Men's Wear Woolens and Worsteds, and Worsted Yarns; 45 sets; 9 combs; 300 looms; steam; dye; sell yarns direct.
- INDUSTRIAL DYEING AND FINISHING (D & F) WORKS;** 3829-3845 Frankford Ave; \$200,000; John G. Campbell, pres; Geo. R. Randall, treas; Chas. S. Randall, supt; Dyers and Finishers Cotton, Woolen and Worsted Yarns, Warps; Piece Goods, Cloakings, Dress Goods, Shirtings, etc; steam; office, at mill; George R. Randall, buyer.
- INGRAM, WM. A.;** 714 N. 43rd. St., W. (B1) Phila.; Linen Yarn Bleachery; Bleaching Yarns. (Removed from Cheltenham.)
- INTEGRITY KNITTING MILLS;** Chas. C. (K) Klein, prop; 2850 Marshall St; Cotton Hose; 228 needles; 22 knitting machines.
- IROQUOIS KNITTING MILLS;** Ashmead (K) and Wakefield Sts.; Germantown; Harlow D. Gaines, pres.; Sam'l Corkran, sec. and treas.; F. W. Briggs, supt.; Men's Ribbed Underwear, in finer grades; 12 knitting machines; 25 sewing machines; steam; sell direct.
- IRWIN, A. D. & BRO;** Columbia Mill; (W) Turner and Masher Sts; Map G; Sq. 54; A. Atkinson, supt; Cassimeres and Dress Goods; 140 looms; steam; Bacon & Co, N. Y., s. agts; R. S. Irwin, buyer.
- IRWIN, R. S. & Co;** Columbia Thread Works; (Now Hughes Mfg. Co.)
- IVINS, DIETZ & METZGER Co;** Lehigh (W) Ave. and Marshall St; Map A; Sq. 61; \$1,000,000; Wm. Ivins, pres; Jacob Dietz, treas; J. R. Hogg, sec; Wm. Ivins, Jr., supt; Brussels, Ingrain and Wilton, Art Squares, Rugs, Etc; 200 looms; steam; dye; sell direct; Wm. Ivins, Jr, buyer. (Buy yarns.) (Also Norristown, Pa.)
- JACKSON, DAVID & SON;** Coral and (W) Adams Sts; Map C; Sq. 62; Ingrain Carpets; 55 looms; steam; sell direct.
- JAGGERS, THOS.** *Out of business.*
- JAMES, G. L.;** Roxborough Mills, Walnut (W) and Lauriston Sts; Manayunk; Map F; Sq. 81; Carpet Backing and Blanket Yarns; 3 sets; steam; sell direct; G. L. James, buyer.
- JAMESON'S, D. SONS;** Hope Carpet Mills; (W) 1732-34-36-38 Blair St; Map C; Sq. 54; Ingrain Carpets, Rugs, Scrub Cloths, etc; 23 looms; steam; sell direct; firm, buyers. (Buy all kinds of yarns.)
- JARVIS, DAVID, AGT;** 235 Wistar St; Ger. (K) mantown; Map D; Sq. 91; Hosiery and Women's Waists, Athletic Suits, Tights and Sweaters; 30 knitting machines; steam; E. M. Townsend & Co, N. Y., s. agts.

- JENKS, W. A.**, 9th and Dauphin Sts; (**W**) Map A; Sq. 61; R. J. Prince, supt; Worsteds, Woolens and Cloakings; 35 looms; steam; R. J. Prince, buyer.
- JOHNSON, JOS.** (formerly Wm. Johnson (**W** & Son); Allegheny and Kensington Aves; Map C; Sq. 71; Joseph Johnson, supt, and buyer; Carpet Yarns and Waste; 4 sets; 440 spindles; sell direct, and J. H. Schaefer, s. agt.
- JOHNSON, J. WESLEY.** Emerald and Al. (**W**) Lehigh Ave; Map C; Sq. 71; Rug and Carpet Yarns; 750 spindles; 3 sets; steam; sell direct; J. W. Johnson, buyer.
- JOHNSTON BROS.** (formerly Wm. Johnston (**W**) ston); Leverington Ave. and Wilde St; Manayunk; Woolen Shoddy and Medium Woolen Yarns; 9 cards; 3 garnett machines; 2 pickers; steam; sell direct; 106 N. Front St, Wm. Johnston, Jr, buyer.
- JONES, GEO. F. & SON.** 866 & 868 N. Pallas (**K**) St; Fine Gauge Ladies' Hose, Silk Finished; 25 full automatic knitting machines; steam and gas; sell direct; Geo. F. Jones, buyer.
- JONES, NEWTON.** (formerly Geo. S. (**W**) Lees & Co.); N. 20th and Cora Sts.; Germantown; Woolen Yarns for Carpets, single and double reel; 985 spindles; 2 sets; steam; sell direct.
- JOSEPHS, & HERBST.** Florence Mills; 1738 (**S**) No. 2nd St; Map C; Sq. 54; Silk and Satin Curtains, Draperies, Table Covers and Fine Upholstery Fabrics; 12 looms; steam; sell direct.
- KEDWARD, WM.** Cedar St, Dye & Bleach (**D**) Works; (P. O. Address, Station E); Cedar, above Somerset St; Map B; Sq. 37; Dyer and Bleacher of Cotton Warps and Skein Yarns; steam; office, 222 Chestnut St.
- KEEFER, WM. B.**; (formerly Keefer & (**W**) Coon); Oxford Carpet Mill; 7th and Huntington Sts; Map A; Sq. 61; Ingrain Carpets; 107 looms; steam; dye; sell direct.
- KEEGAN, WM.** Empire Mill; Trenton (**C**) Ave. and Sergeant St; Map A; Sq. 62; Shirts and Dress Goods; 120 looms; steam; sell direct; Wm. Keegan, buyer.
- KEIM, J. R. & Co.** Shackamaxon Wor. (**W**) sted Co; Allegheny Ave. and Hancock St; Map A; Sq. 70; A. F. Spitzle, supt; Piece Dyed and Fancy Worsteds; 60 looms; steam; dye; sell direct.
- KELLY, EDWARD W.** 5126 Wakefield St; (**K**) Germantown; Map D; Sq. 92; Cotton Hosiery; 65 knitting machines; steam; sell direct; Mr. Kelley, buyer.
- KELLY, FRANCIS.** 1724 Hancock St; Map (**W**) A; Sq. 61; Cotton, Wool and Jute Shoddy and Waste; 4 pickers; 1 willow; 1 burr picker; 1 dryer; steam.
- KEMMERLING, WM.**; Tonawanda Mill; (**W**) Wayne Junction; Map D; Sq. 84; Serges, Chevots, Etc.; 32 looms (commission weaving). (Buy worsted yarns in all numbers.)
- KEMPF BROS.** 2614 Martha St; Map (**C**) C; Sq. 62; Waste; 3 waste machines; 1 willow; steam; sell direct; John H. Kempf, buyer.
- KENDRICK, JAMES R.** 133 Harvey St; Ger. (**K**) mantown; Map D; Sq. 91; Elastic Hosiery; 18 knitting machines; steam; salesroom, 23 East 14th St, N. Y.
- KENNEBEC WORSTED CO, LTD.** (Successors (**W**) sons to Herbst & Jones); 2032 Nandain St; Map B; Sq. 36; Robt. H. Hey, pres.; Sam'l Springer, sec. & treas. and gen'l mgr; John W. Jones, supt.; Worsteds Yarns, up to 36s; 5 combs (English System); 5 sets; 4064 spindles; steam; sell direct; John W. Jones, buyer.
- KENNEDY & BRITT.** Conshohocken Dye. (**D**) ing & Finishing Works; Mascher and Jefferson Sts; Map C; Sq. 54; Dyeing of Worsteds Cloakings, Coatings, Etc; steam; dye; Benj. Britt, buyer.
- KEN-INGTON SKEIN SILK DYE WORKS.** (**D**) P. T. Lyle, prop.; Dye Heavy Weighted Colors and Black Schappe and Spun Silk for Velvet; steam.
- KENTWORTHY, T. & Bro.** Shurs Lane (**W**) Mills; Shurs Lane; Manayunk; Map F; Sq. 73; Worsteds and Woolen Carpet Yarns; 14 cards; 7 combs; steam; sell direct; office, 111 Church St; firm, buyers.
- KERKESLAGER, IRVIN C.** Keystone Mills; (**W**) Leverington Ave. and Wilde St; Manayunk; Map F; Sq. 72; Wool and Cotton Waste, Carpet and Rug Yarns; 6 sets; 900 spindles; 2 pickers; 1 waste machine; steam; sell direct.
- KERR, JAMES H.** 1832 Harold St, Madras (**C**) Shirts, Chambrays and Linings; 300 looms; steam; dye; sell direct; James H. Kerr, buyer. (Buy cotton yarn, 30s warps and 40s filling.)
- KERSHAW, JNO. W.** 25th and Callow. (**C**) hill Sts; Map A; Sq. 44; Turkish Towels, etc; 50 looms; steam; sell direct; J. W. Kershaw, buyer.
- KEYSTONE FAST BLACK DYE WORKS.** (**D**) John Boston, prop; 1838-40 E. Huntington St; Dyers of Hosiery; steam.
- KEYSTONE SILK WEAVING CO; LTD.** 17th (**S**) St. and Lehigh Ave; Ira S. Reis, pres; Chas. S. Bowers, treas; Woven Labels and Shoe Toppings; 24 looms; steam; sell direct; firm, buyer.
- KEYSTONE SPINNING MILLS CO.** 1631 No. (**W**) 2nd St; Jos. P. Truitt, Jr, supt, and buyer; Rug, Double Reel, Fringe, and all other Woolen Carpet Yarns, also Fine Woolen Yarns for Weaving Purposes; Also Scouring and Carbonizing of Wool; 10,000 mule spindles; 22 carpet and 3 fine sets cards; steam; sell direct.
- KILLIAN BROS.** 4618-20 E. Thompson St; (**S**) Bridesburg; Silk Ribbons; 6 looms; steam; Bowen & Dungan, 715 Arch St; Phila, s. agts; George Killian, buyer.
- KITCHEN, JAMES G. & Co.** Chelton Ave; (**W**) Germantown; Map D; Sq. 91; Woolen Shoddy; 33 cards; sell direct; office, 55 No. Front St.
- KITCHENMAN, JOHN.** York and Hope Sts; (**D**) Map A; Sq. 62; Dyer Yarn, Woolen; steam.
- KLAUDER & Bros.** Leamy and Lippin. (**D**) cott Sts.; Dyers Hosiery, Yarns and Fabrics.
- KNEEDLER & Co.** Lenox Mills; Brides. (**C**) burg; not shown on map; (P. O. Address, Station F); Tickings and Cassimeres; 210 looms; steam; sell direct; Henry M. Kneedler, buyer.
- KOCH, JUSTUS.** Oxford Knitting Mill; (**K**) 1051 Frankford Rd; Map C; Sq. 54; W. K. Thudium, mgr; Cardigan Jackets, Sweaters, Golf Hose and Knit Goods; 195 knitting machines; steam; sell direct; office, 89 Franklin St, N. Y.; W. K. Thudium, buyer. (Buy 16s to 20s cotton yarns, also worsted yarns.)
- KOCH, JUSTUS & Co.** Kensington Knit. (**K**) ting Mill; 437 Moyer St; Map C; Square 54; 5 sets; 275 knitting machines; steam; Hineman, Vezin & Co, N. Y., Thompson, Foust & Co, Phila, s. agts; Justus Koch, buyer. (Buy cotton yarns.)
- KRAGER, J.** 1543-45 Ruan St; Frankford; (**C**) Danask Tablecloths; 12 looms; steam; H. C. Childs & Co, N. Y., s. agts; also sell direct; J. Krager, buyer.
- KRAUSE, CHAS. B.** 2067 Arizona St; (**W**) Map C; Sq. 62; Cottage and Venetian Carpets; 22 looms; hand power; sell direct; C. B. Krause, buyer.
- KREMER, CHAS. E.** Delaware Knitting (**K**) Mill; N. W. cor. Race and 11th Sts; Map B; Sq. 45; Ladies' East Black Ribbed Underwear and Union Suits; 30 knitting machines; sell direct.

- KREMER, THEO. E. & CO;** Crescent Knit. (K) ting Mill; 11th and Race Sts; Map B; Sq. 45; Ladies' and Misses' Cotton and Worsted Ribbed Underwear; 50 knitting machines; steam; sell direct.
- KRIEBEL, CHAS;** 835 Ellsworth St; Rag (W) Carpets; 10 looms; hand power; sales-room, 1123 South 8th St.
- KROOK & BRUCH CO, THE, LTD.;** Lincoln (W) Mills; \$6000; W. H. Bruch, pres.; Robt. Krook, treas.; Carpet Yarns, Gray Ingrains and Rug Yarns; 6 sets; steam; sell direct; Wm. A. Bruch, buyer.
- KROUT & FITE MFG. CO;** Allegheny (C & S) and Emerald St; Map C; Sq. 71; \$50,000; Geo. W. Krout, pres; John E. Fite, treas; Jules Bloch, sec; Silk and Cotton Narrow Fabrics, Braids; Tapes, Silk and Cotton Underwear Edgings; 125 looms; steam; bleach; sell direct; Jules Bloch, buyer. (Buy yarns.)
- KUESTNER, JOHN;** Belmont Carpet & (W) Art Square Mills; Emerald St, above Cumberland St; Map C; Sq. 62; Peter Kuestner, supt; Ingrain Carpets, Art Squares, Stair Carpets, Ingrain Mats and Rugs, 20 looms; steam; J. G. Burrows, Carl Bremer, W. W. Zapp, and H. C. Dalby, s. agts., John Kuestner, buyer.
- LAFFERTY BROS;** Adam & Pine Sts; (C) Frankford; Map E; Sq. 80; Damasks and Upholstery Goods; 10 looms; 1 winder; steam; E. H. Hamilton & Co, N. Y., s. agts; firm, buyers. (Buy 3 ply cotton yarns.)
- LAFFERTY, M;** Coral and Taylor Sts; (W) Map C; Sq. 62; Wool and Merino Yarns; 3 sets; 2000 spindles; steam; A. J. Cameron & Co, Phila., s. agts; firm, buyer.
- LAFFERTY, JOHN, & BRO;** Gun- (D & F) ner's Run Dye and Finishing Works; Frankford Ave. and Westmoreland St; Map E; Sq. 71; Woolen, Worsted and Cotton Cloth Dyeing and Finishing; steam; dye; firm, buyers.
- LANARK KNITTING CO;** 4155 Frankford (K) Ave; Frankford; Map E; Sq. 80; William Baird, pres. and supt; Wm. A. McLoughlin, treas; Ribbed Underwear; 15 knitting machines; steam; W. H. Rowe & Son, s. agts.
- LANDENBERGER, J. W. & CO;** Randolph (K) Mills; 1713 Randolph St; Ribbed Underwear, Sweaters, Skirts and Hosiery; E. M. Townsend & Co, N. Y., Boston, Phila. and Chicago, s. agts.
- LANE, MRS. E. M. (successor to Geo. H. (K) Gilbert);** 4555 Lena St; Germantown; Map D; Sq. 92; Seamless Cotton Hosiery; 30 knitting machines; steam; dye; sell direct.
- LANSDOWNE MFG. CO, THE; (formerly (W) M. Jones);** Emerald and Tioga Sts; Map E; Sq. 71; \$10,000; Francis G. Taylor, pres; H. B. Nichols, treas. and m. r.; Henry W. McKee, supt; Wool, Shyria and Jute Rugs; 60 looms; 2 finishing and 2 sewing machines; 1 fringing machine; steam; sell direct; 410 Arch St, main office. (Buy cotton, wool and jute yarns.)
- LAWLOR, THOS. L.;** Cumberland and (C) Third Sts; Map A; Sq. 61; Flannels and Cotton Goods, also Shirts; 50 looms; steam; sell direct; T. L. Lawlor, buyer.
- LAYCOCK, JOHN;** 2627 Mutter St.; Cotton (C) Tapestry Curtains; 2 looms; R. Bierworth, 41 Union St., N. Y., s. agt.
- LAZOWICK, MORRIS;** 517-519 Lombard (K) St; Ladies' Fast Black, Heavy Weight and Light, also Gray Mixed Color Hose; 10 knitting machines; sell direct; M. Lazowick, buyer.
- LEA, SAMUEL, & SON;** Times Finishing (F) Works; 1148 American St; Map C; Sq. 53; Thos. Lea, supt; Finishing of Cotton Goods, Napped Goods a Specialty; steam.
- LEAVERS, WALTER & CO;** (formerly (K) Whittle & Leavers); 726 W. Girard Ave; Seamless Hose, Ladies' and Misses' and Mens' Cotton Hose; 100 knitting machines; steam; Wm. Iselin & Co, N. Y., s. agts. (Buy all kinds and numbers cotton yarns.)
- LEE HOSIERY MILLS;** Geo. B. Pfingst, (K) prop; 3d & Cumberland Sts; Men's and Infants' Full Fashioned Cotton Socks; 70 knitting and 60 sewing machines; steam; Wesendonck, Lorenz & Co., s. agts; Geo. B. Pfingst, buyer.
- LEE, JAMES H.;** Emerald and Willard (W) Sts; Woolen Carpet Yarns; 1900 spindles; 6 sets; sell direct; James H. Lee, buyer. *Burned April, 1902, will rebuild.*
- LEHIGH MANUFACTURING CO;** Fourth St. (C) and Lehigh Ave; Map A; Sq. 61; James Cooper, supt; Lace Curtains; 115 looms; steam; dye; E. W. Knapp, 890 Broadway N. Y., s. agt; firm, buyers.
- LEICESTER & CONTINENTAL MILLS (W & K) CO, THE; (Incorp'd) Lena and Amat Sts; Germantown; N. T. Polwell, pres; Jas. Dolson, vice-pres; Wilson H. Brown, treas; Everett H. Brown, see; Sweaters and Eiderdowns, Knit Goods and Wool and Merino Yarns; 10,000 spindles; 10 sets; 150 knitting machines; steam and electric; dye; sell direct.**
- LEITENBERGER, LOUIS;** 1927 E. Clear. (W) field St; Map C; Sq. 63; Ingrain and Rag Carpets; 14 looms. (Buys yarn.)
- LEITHEAD, R. S. & SONS;** Huntingdon (D) and Collins Sts; Map C; Sq. 62; Dyers Woolen Yarns; steam; dye; R. S. Leithead, buyer.
- LESSIG, A. & A;** 1907 No. 6th St; Map C; (C) Sq. 61; Coverlets, Dusters and Towels; 19 looms; steam; sell direct; A. Lessig, buyer.
- LEWIS, ROBT;** Richmond and Brill (C & S) Sts; Bridesburg; not shown on map; Curtains, Table Covers, Couch Covers and Draperies; 52 looms; steam; salesroom, 611 Harford Bldg, 41 Union Sq, N. Y., and 61 Arcade Yonge St, Toronto; Robert Lewis, buyer.
- LINTON, HORACE & BRO;** 1824 East (C & S) Clearfield St; Map C; Sq. 71; Silk and Cotton Narrow Fabrics and Cigar Ribbons; 16 looms; sell direct.
- LITTLEWOOD, G. J. & SONS, (LTD);** Al- (D) bion Dye & Bleach Works; Main St, below Walnut Lane; Manayunk; Map F; Sq. 73; Dyers and Bleachers of Cotton, Cotton Warp and Skein Yarn; steam; office, 132 Chestnut St.
- LOCKHART, ISAAC;** Howard St. and (W) Montgomery Ave; Map C; Sq. 54; Ingrains; 16 looms; steam; sell direct; I. Lockhart, buyer.
- LOCKHART, WM;** Howard and Lehigh (W) Aves; Station Q; Map A; Sq. 61; Robert Winchester, supt; Ingrains; 30 looms; steam; sell direct; Wm. Lockhart, buyer.
- LODGE, JOHN F. & SONS;** Pequod (C & W) Mills; Hart Lane and Emerald St; Map A; Sq. 62; Cotton and Wool Carpet Yarns; 4900 spindles; 27 sets; steam; sell direct.
- LOEB, LIPPER & CO;** Keystone Braid (S) Mills; 317 Darien St; Map B; Sq. 45; Dress and Millinery Trimmings and Braids; 100 looms; 600 bradders; 40 knitting machines; steam; sell direct; salesrooms, 605 Broadway, N. Y.; J. Loeb, buyer.
- LOMAX, JOSEPH;** Mascher and York Sts; (W) Map C; Sq. 62; Ingrains; 26 looms; steam; sell direct; Jos. Lomax, buyer. (Buys 14/2 worsted and 14/2 cotton skeins.)
- LONG & BOWERS. Out of business.**
- LONG, BROS. & CO;** Quaker City Mills; (W) 3rd and Ontario Sts; Map A; Sq. 69; Chas. H. Harding, pres; David C. Nimlet, treas; Jas. H. Steele, supt; Woolen and

- Worsted Dress Goods; 430 looms; steam; dye; salesrooms, 203 Church St, Phila, 58 Leonard St, N. Y.; Oliver N. Long, buyer.
- LORD BROS;** 2838 Terrace St; Man- (C & W) ayunk; Map A; Sq. 74; Cotton and Wool Wastes for Wiping and Packing; steam; firm, buyers; (also dealers in Cotton, Cotton and Wool Wastes.)
- LORD, JOHN, SONS;** 2838 Terrace St., (W) Manayunk; Map A; Sq. 71; Carpet, Backing, Blanket and Rug Yarns; 4 sets; 450 spindles; steam; firm, buyers.
- LORIMER'S W. H, SONS Co;** Ontario and (D) Lawrence Sts; Map A; Sq. 69; \$20,000; John H. Lorimer, pres; Walter A. Lorimer, treas; Joseph H. Lorimer, supt; Mercerized Yarns; Dyers of Woolen, Worsted and Cotton Yarns, raw stock cotton and wool, mercerizing of cotton in skein and warp, 2 or more ply; steam.
- LOWE, PERCY I;** 624-626 Race St; W. H. (K) Jenkins, mgr; Ladies', Misses' and Infants' Underwear, Children's Waists and Knit Skirts; 10 knitting; 7 sewing machines; steam; sell direct.
- LUDWIG, EDWARD, & SON;** Palethrope (W) and Somerset Sts; Map A; Sq. 61; Carpets; 16 looms; steam; sell direct; E. Ludwig, buyer.
- LUTILEN, L. B;** J and Estanga Sts; (D) Cotton Yarn Dyer; steam; E. Veit, mgr, buyer.
- LULL BROS;** 1237 Brown St; Spool and (S) Sewing Silk.
- LUPTON, OLIVER & Co;** Whittington (W) Mill; Manayunk; Coatings and Worsted Coatings and Stockinets; F. Victor & Achelis, N. Y., s. agts. (Buy lustre and mohair yarns on spools or in skeins.)
- MACELROY & SCHOLES.** *Out of business.*
- MCCALLUM & MCCALLUM.** *Out of business.*
- MCCAULEY, T;** Collanad Dye Works; (D) 2109 E. Somerset St; Map C; Sq. 62; Dyers of Cotton Yarns and Hosiery; steam; T. McCauley, buyer.
- MCCLOSKEY, JAMES;** Margaret and Bur (D) mada Sts; Bleachers of Cotton Goods, Skein Yarns, Warps, Knit Goods, Toweling, etc; steam. (Contemplates building a new mill.)
- MCCOMESKY, THOS;** Keystone Cordage (J) Works; 3729 Frankford Ave; Map E; Sq. 71; Harness Twine, Loom cord; hand power; sell direct; Thos. McComesky, buyer.
- MCDOWELL BROS;** Belgrade Carpet (W) Mills; 2137-2143 E. Firth St; Ingrains; 20 looms; steam; H. C. Da bey, 115 Worth St; N. Y., s. agt.
- MCDOWELL, DAVID;** Howard, below (W) Berks St; Map C; Sq. 54; Ingrains; 42 looms; steam; sell direct; David McDowell, buyer.
- MCGILL & Co;** 2218-20 Martha St; Map C; (W) Sq. 62; Smyrna Rings and Mats; 16 looms; hand power; sell direct.
- MCGINLEY & KLENK;** Auburn St and (W) Trenton Ave; Geo. C. Klenk, supt; Wool and Merino Yarns; 2 sets; 1800 spindles; steam; sell direct; J. W. McGinley, buyer.
- MCGINNIS, M. J. & Co;** Adams Ave. and (C) Church St, Frankford; Map E; Sq. 80; Table Damask; 16 looms.
- MCGREGOR, WALTER;** 1014 Greenwood (C) Ave; Towels; 3 hand looms.
- MCHLWAIN & Co;** Diamond Mills; 1645 (S) Marshall St; Map C; Sq. 53; John Bray, supt; Curtain Material, Draperies, Upholstery Goods; 70 looms; steam; dye; T. D. Keveney & Co, s. agts; also sell direct; Wm. McIlwain, buyer.
- MCKAIG & PULSTER;** Adams and Emer- (K) land Sts; Cut and Seamless Hosiery; 160 knitting machines; steam; sell direct; Mr. McKaig, buyer.
- MCKECHNIE, JAMES;** Kensington Ham- (C) mock Mill; 2349-2359 Mascher St; School Bags, Hammocks and Textile Novelties; 6 looms; hand power; sell direct; James McKechnie, buyer.
- MCMANN, WM. G;** Station K; 2168 E. Firth (K) St; Map A; Sq. 62; Cut and Seamless Cotton Hosiery; 80 knitting machines; steam; S. Hazard Halsted, N. Y., s. agt; W. G. McMann, buyer. (Buy 16s to 20s cotton knitting yarn.)
- McNAIR, THOS;** Mascher and York Sts; (W) Map C; Sq. 62; Dress Goods; 24 looms; sell direct.
- McPHERSON, SAM'L;** 2632 Mascher St; (C) Map C; Sq. 62; Quilts, Table Diaper; 25 looms; steam and hand power; Whitman & Phelps, N. Y., s. agts; also sell direct; Sam'l McPherson, buyer.
- MAGRAN, E;** Mascher and Turner (C) Sts; Map C; Sq. 54; Coat Linings and Shirts; 104 looms; steam; sell direct; E. Magran, buyer. (Buy cotton yarn.)
- MALCOLM MILLS Co;** Orchard and (C, S & W) Church Sts; Frankford; Map E; Sq. 80; \$100,000; Chas. M. McCloud, pres; J. D. W. Gross, treas; F. R. Merbitz, supt; Fancy Yarns, Polished Thread, Etc; steam; dye; salesroom, 229 Chestnut St; C. M. McCloud, buyer.
- MANCHESTER FINISHING WORKS;** Mascher (F) St above Lehigh Ave; Map C; Sq. 62; Benj. Race, pres and supt.; Finishing Linen, Cotton, Silk and Woolen Dress Goods and Cotton Men's Wear; Benj. Race, buyer.
- MANSFIELD, JOSEPH W;** H21 Ridge Ave; (K) Map A; Sq. 52; Cardigans, Athletic and Theatrical Goods; 14 knitting machines; hand power; sell direct; J. W. Mansfield, buyer.
- MARGERISON, W. H. & A. E. & Co;** Emer- (C) and Sargeant Sts; Map C; Sq. 62; A. E. Margerison, supt; Turkish Towels and Fancy Novelties; 60 looms; steam; sell direct; Wm. H. Margerison, buyer.
- MARION HOSEERY MILLS;** O'Connell & (K) Co. (successors to F. Buckhalter & Co.); Lehigh Ave. and Mascher St; Map C; Sq. 62; Ladies' Fine Gauge Cotton Seamless and Cut Hosiery; 130 knitting machines; steam; L. J. Riggins, N. Y., s. agt; also sell direct.
- MARTIN, JAMES, & Co;** Richmond (D & Pr) Dyeing & Printing Works; P. O. address, Station E; Richmond and Tioga Sts; Map E; Sq. 64; Wm. L. Martin, vice-pres.; Thos. J. Martin, sec. and treas.; John Williams, supt; Cotton Goods, Printing and Dyeing; steam.
- MARTIN, & Co;** 305 Race St; Map B; Sq. (F) 45; Finishers; steam; L. J. Martin, buyer.
- MARTIN & GAW;** Somerset and Hancock (W) Sts; Map C; Sq. 64; Ingrain Carpets and Art Squares; 14 carpet looms; 2 for Art Squares; steam; sell direct.
- MASCOT HOSEERY Co;** S. E. cor. Mascher (K) and Turner Sts; Map C; Sq. 54; David and Chas. Rosenbaum, agts; Phillip Saller, supt; Cotton Seamless Hosiery; 93 knitting machines; steam; Philip Saller, buyer.
- MASLAND, C. H. & SONS;** (formerly Mas- (D) land Bros. & Richm) Amber and Westmoreland Sts; Map E; Sq. 71; Dyers of Cotton, Woolen and Mixed Yarns; steam; firm, buyers.
- MASLAND, C. H. & SONS;** Amber Carpet (W) Mills; Amber and Westmoreland Sts; Map E; Sq. 71; Ingrain, Velvet and Tapestry Carpets; 224 looms; steam; dye; W. & J. Sloane, N. Y., s. agts; firm, buyers.
- MASLAND, JOSEPH H, Co;** (incor. (C & K) 1895); Quaker City Textile Mills; 4817 Germantown Ave; Map D; Sq. 84; \$100,000; John Robinson, pres; Joseph H. Masland, sec. and treas; Hammocks, School Bags,

- Etc; 24 looms; 2 knitting and 18 sewing machines; steam; sell direct. Jos. H. Masland, buyer. (Buy cotton yarn.)
- MASLAND, J. W. & Co;** Clearfield and (D) Jasper Sts; Map C; Sq. 71; Carpet Yarn Dyer; steam.
- MATHES BROS;** 110 Turner St; Map C; (D) Sq. 54; Dyers Cotton Yarns; steam.
- MATED MILLS;** 1824 Cadwallader St; Map (S) C; Sq. 53; Tapestry Curtains, Covers etc; 37 looms; sell direct; N. K. Regar, buyer.
- MAURER, F. W. & SONS;** 528 Cherry St; (S) Map B; Sq. 45; Window Shade Trimmings; 50 looms; steam; W. R. Fairclough, Boston, s. agt; Joseph Maurer, buyer.
- MAWBY, J. V.;** 1614 Ridge Ave; Map A; (W) Sq. 52; Rag, List and Shawl Fringe Carpets; (buys yarn); 11 looms; sells direct.
- MAWSON, JOHN, HAIR CLOTH CO.;** (C&W) Coral and Dauphin Sts; Map C; Sq. 62; \$6000; John Mawson, pres.; David Spencer, supt; Hair Cloths and Imitations; also Flannels and Cotton and Worsted Dress Goods; Coat Linings and Duck Linings; 73 looms; steam; dye; sell direct; John Mawson, buyer. (Buy warps and cops.)
- MAYBAUM & Co;** 2240 No. 9th St; Map A; (K) Sq. 61; Cotton Cut Seamless Hosiery; 100 knitting machines; steam; sell direct; L. W. Maybaum, buyer.
- MEGOWAN, ROBT;** Standard Mills; (W & C) Adams and Church Sts; Frankford; Map E; Sq. 80; Cotton and Woolen Dress Goods and Shirtings; 250 looms; steam; Battelle, Hurd & Co, N. Y., s. agts; Robert Megowan, buyer.
- MEINHAARDS, O. J. SONS;** 'Emerald, (D) above Westmoreland St; Map E; Sq. 71; Dyer Cotton, Woolen and Jute Yarns; steam.
- MELLOR, R. & Co;** Unity and Wingo; (C) Hooking Sts; Frankford; Map E; Sq. 80; Bating; 4 cards; steam; sell direct.
- MERCURY MILLS;** Adam Fink; Adam (C) Fink; Adams & Church Sts; Map E; Sq. 80; Turkey Red Damask and Center Covers; 16 looms; steam; sell direct; Adam Fink, buyer.
- MERKLEE, D. C.;** 36 No. 4th St; Map B; (S) Sq. 45; Dress and Cloak Trimmings; 5 looms; hand power; 8 braiding machines; sell direct.
- MEZ & BRUHM;** Ontario Mill; 2nd near (W) Columbia Ave; Map C; Sq. 54; Dress Goods; 70 looms. C. A. Autmordt & Co, N. Y., s. agts.
- METZ M. A. & BRO;** 319 No. 2nd St, (K) Hand-Made Knit Goods; Bootees, Sacques, Hoods and Fascinators; employ 1000 outside hands; Husted, Hess & Co, s. agts; M. A. Metz, buyer.
- MEYER, H. H.;** 2045 E. Susquehanna Ave; (W) Rag and Jute Carpets; 16 looms; hand power; sell direct.
- MILLER & SONS;** 3839 Reno St; C. R. Miller, supt; Ladies' Fine Seamless Hosiery with Lace Effect; 12 knitting machines; steam; sell direct.
- MILLER BROS;** 214-216 W. Dauphin St; (K) Map C; Sq. 61; Fine Gauze Seamless Hosiery; 22 knitting machines; 18 automatic ribbers; 3 loopers; steam and electric; W. H. Berry, 43 Leonard St, N. Y., s. agt; firm, buyers. (Buy 22s cotton yarn.)
- MILLER, JACOB, SONS & Co;** Borich (C&W) Mills; 16th and Reed Sts; Map A; Sq. 28 S. Miller, supt; Cotton and Woolen Goods; 250 looms; steam; dye; sell direct; 926 Market St; firm, buyers.
- MILLER, NATHAN;** York and Mascher (W) Sts; Map C; Sq. 62; Ingrains; 16 looms; steam; sell direct; N. Miller, buyer.
- MILNE, C. J. & SONS;** Washington Ave, (W) from 10th to 11th Sts; Dress Goods, Shirt and Fine Textiles; 275 looms; steam; sell direct; N. Y. office, 54 Leonard St.
- MINDERJOHN, PETER;** 2534 No. Front St; (W) Rag and Stair Carpets; 2 looms; hand power.
- MISKELL, JOHN;** 1939 Clearfield St; (W) Damask Stair Carpet and Ingrains; 6 looms; hand power.
- MOORE & BRO;** Phoenix Carpet Mill; (W) Howard St; Map C; Sq. 62; Ingrains; 30 looms; steam; sell direct; Wm. H. Moore, buyer. (Buy yarns.)
- MOORE, ALFRED F.;** 200 No. 3rd St; Map (C) B; Sq. 45; Insulated Electric Wire; steam; sell direct; A. F. Moore, buyer. (Buy yarns, 10/2, 12/17, 60/17, 100/L.)
- MOORE, C. & Co;** 500 Market St; mill (C&F) at Newark, N. J.; Map B; Sq. 36; Harness Twine, Linen Yarn, Etc; steam; sell direct.
- MOORE, I. E. & Co;** Kensington Ave. (F&D) and Huntingdon St; Map C; Sq. 62; Finishers and Dyers; Cotton, Woolen, Worsted Goods; steam.
- MOORE, SAM'L. & SONS;** 3211-23 Amber (D) St; Cotton and Worsted Yarn Dyers.
- MORGAN, H. F.;** 2119 E. Arizona St; Map (W) C; Sq. 62; Ingrains; 30 looms; hand; sell direct; H. F. Morgan, buyer.
- MORITZ, CARL J.;** 125 No. 4th St.; Shade (S) and Dress Trimmings, Window Laces, Embroidery, etc.; 5 looms; 30 machines; steam.
- MORRIS & OTT;** Glen Rock Mills; Burn- (W) side St, Manayunk; Map F; Sq. 73; Jas. Ott, supt; Cotton, Merino and Woolen Yarns; 4 sets; 2400 spindles; steam; dye; sell direct, and J. Corbett & Son, Phila., s. agts; John G. Morris, buyer.
- MORRIS, E. H.;** Walnut Lane and Free. (W) land Ave; Manayunk; Map F; Sq. 73; Carpet Yarn; 9 sets; steam; sell direct; E. H. Morris, buyer.
- MORRIS, G. J.;** 1522 Frankford Ave. (W) Shawls; 1 hand loom.
- MOSS ROSE MFG. CO.;** Allegheny Ave. (C & S) and Hancock St.; 17th and Broadway, Hartford Bldg, N. Y.; Map A; Sq. 61; \$20,000; S. Selig, Joseph Elias and M. A. Kaufmann; Silk and Cotton Upholstery Goods, Curtains and Table Covers; 75 looms; steam; sell direct; firm, buyers.
- MOTTRAM, THOS.;** Wissahickon Knit- (K) ting Mills; 274 West Rittenhouse St; Germantown; Map D; Sq. 91; Cardigan Jackets, Woolen & Worsted; 20 knitting machines; steam; sell direct.
- MT. VERNON WORSTED MILLS;** J. & J. (W) Dobson; Manayunk; Map F; Sq. 73; Samuel Gidley, supt; Worsted Yarns, 9s to 50s; (English System); 10 combs; 15 sets; 9000 spindles; sell direct; office, 26 No. Front St.
- MULLHOLLAND, THOMAS;** Adams St, (C & W) Frankford; Cotton and Woolen Goods, Mitchelline Quilts; 50 looms; steam; sell direct.
- MULLINEAUX, CLEGG & Co;** (successors (W) to Clegg & Bro); Chatham Mills; Howard and Berks Sts; Map C; Sq. 54; shoddy and Extracts; 4 sets; 4 pickers; steam; dye.
- MURPHY & BRO;** 16th and Fitzwater (C&W) Sts; Map B; Sq. 26; Cotton, Woolen and Worsted Goods; 318 looms; steam; dye; sell direct. (Buy all kinds of yarn.)
- MURPHY, MATTHEW, & SON;** 3rd and Cum- (C) berland Sts; Map A; Sq. 61; Tapes, Bindings, etc.; 80 looms; steam; bleachery; sell direct; Wm. M. Murphy, buyer. (Buy 10/1 to 70/3 -kein and 12/1 to 10/1 warps.)
- NATIONAL KNITTING WORKS;** R. Gutsche, (K) prop.; S. W. cor. Jefferson and Randolph Sts.; Cardigan Knit Jackets, Sweaters, Patent Elastic Top Bicycle Hose, Underwear and Fancy Knit Goods; 150 knitting machines; 50 sewing machines; steam; sell direct; R. Gutsche, buyer.

- NATIONAL SPINNING Co;** Orchard St; (**C**) Frankford; Map E; Sq. 80; Joshua Garsed, treas.; A. W. Garsed, supt.; Cotton Hosiery Yarns; 2200 spindles; steam; James E. Mitchell & Co., Phila., s. agts.; Joshua Garsed, buyer. (Run in connection with Wingohocking Mills Co.)
- NELSON, HUGH;** Columbia Carpet Mills; (**W**) 2nd and Huntingdon Sts; Map C; Sq. 62; Ingrain Carpets; 26 looms; steam. (Buy worsted yarn.)
- NEWBOLD & Co;** 3338 Collins St; H. (**W**) Anderson, supt.; Rugs and Carpets; 65 looms; steam; sell direct; W. Newbold, buyer.
- NEWSOME, HERBERT;** Wayne Junction; (**S**) Satin Linings, Silks and Dress Goods; 50 looms; steam; McDonnell, Stout & Co., 1011 Filbert St., Phila., s. agts.
- NEWTON, HERBERT B;** 139 Oxford St; (**C**) Map C; Sq. 54; Tapestry Curtains and Table Covers; 20 looms; finish; The Allison Co, N. Y., s. agents.
- NEW YORK TAPESTRY MILLS;** 1822-1824 (**W**) Cadwallader St; Map C; Sq. 53; Fine Upholstery Goods, Curtains; 30 looms; Ryan & McGahan, 30 and 32 East 21st St, N. Y., s. agts.
- NIXON, W. K.;** 2121 Waterloo St.; High (**K**) Grade Lisle and Mercerized Underwear; 20 knitting machines; 30 sewing machines; steam; sell direct.
- NOLAN, JOHN;** Keystone Dye Works; (**D**) 1716 Howard St; Map C; Sq. 54; Dye Woolen Yarns; steam; John Nolan, buyer.
- NOON, E. & SON;** 4019 Germantown Ave; (**K**) Map A; Sq. 84; Hosiery and Underwear; 36 knitting machines; steam; dye; Ryan & McGahan, 85 Leonard St, N. Y.; H. McMillan, 1025 Arch St, Phila., s. agts; also sell direct; T. Noon, buyer.
- NORRIS, JOHN;** Commission (**W** & **C**) Weaver; Oxford and Hancock Sts; Map A; Sq. 53; Cotton and Woolen Dress Goods and Shirts; also Towelling; 40 looms; steam; John Norris, buyer.
- NOVELTY ART SQUARE & CARPET Co;** (**W**) Second, above Columbia Ave; \$100,000; Robert C. Hamilton, pres. and supt.; Chas. S. Spangler, treas.; Art Squares; 16 looms; steam; T. J. Keveney & Co, N. Y., s. agts.; R. C. Hamilton, buyer.
- NUTTALL, I. (formerly Nuttall & Green- (Pr halgh);** 236-128 Fountain St; Station O; Printing Textile Novelties on Commission; steam; dye.
- OEHRLE Bros. & Co;** 1002-1004 Arch St; (**S**) Map B; Sq. 45; Upholstery Trimmings, Tassels, Fringes, Gimps, Cards, Loops Rope Portiers, Edgings, Etc; steam; A. C. Oehrle, J. H. Litch, C. I. Hooper, J. N. Stockniet, Percy L. Davis, W. C. Hyde, s. agts; Wm. E. Oehrle, Phila. buyer.
- OLIPHAN MILLS;** Allegheny Ave and (**W** & **S**) Boudinot St; Map C; Sq. 70; John Sloane, N. Y., pres.; Geo. M. Neir, N. Y., treas.; P. Bonnet, supt.; Upholstery Goods; 200 looms; steam; Maron & Remer, N. Y., s. agts. Buy cotton, woolen and silk Yarns, 4 to 120. Formerly at Paterson, N. J.
- OLIVER, ALFRED.** *Out of business.*
- O'NEILL & COONEY;** 1543 Ruan St; Frank (**C**) ford; Damask and Lap Robes; 14 looms; steam; sell direct; firm, buyers.
- O'NEILL Bros;** Howard and Columbia (**W**) Aves; Map C; Sq. 54; Shoddy Waste; 6 waste machines; steam; warehouse, 1613 N. 3rd St.
- O'NEILL, JOHN;** 1621-1623 McKean St; (**W**) Joseph Little, supt.; Shoddy; 3 pickers; 3 cards; steam; dye.
- O'NEIL, WM;** Oxford and Jose. (**C** **W** & **L**) phine Sts; Frankford; Map E; Sq. 80; Cotton, Woolen and Linen Goods, 78 looms;
- steam; finish; J. F. White & Co; s. agts; Mr. O'Neil, buyer. (Buy cotton, woolen, fine counts, and linen yarns.)
- ONTARIO SPINNING Co;** 1729 Philip St; (**C**) Map C; Sq. 54; \$100,000; W. H. Arrott, pres.; J. P. Murphy, sec. and treas.; W. T. Westerman, supt.; Cotton Hosiery Yarns; 5977 spindles; steam; sell direct; W. T. Westerman, buyer.
- ORINORO MILLS;** Ruth St, below Som. (**S**) ercet; Station E; Map C; Sq. 62; \$165,000; S. B. Solomon, pres.; J. H. Solomon, treas.; J. H. Clarke, supt. and buyer; Upholstery Goods; 171 looms; steam; dye; sell direct.
- OSBORNE, OWEN;** Atlas Knitting Mill; (**K**) 4th and Somerset Sts; Station G; Map A; Sq. 61; Cotton, Wool and Silk Seamless Hosiery, also Ladies' Full Fashioned Cashmere Hosiery; 250 knitting machines; steam; sell direct; Owen Osborne, buyer.
- OSBORNE, WM;** Marvins and Montgom. (**K**) ery Ave; Map C; Sq. 53; Bathing Suits, Gymnasium Suits, Golf, Bicycle, Base Ball and Foot Ball Sweaters and Stockings and Eiderdown Goods; 20 knitting machines; steam; sell direct; Wm. Osborne, buyer.
- PALMER, J. S. & SON;** 1711 Randolph St, (**K**) Map C; Sq. 53; Cut and Seamless Hosiery; 100 knitting machines; steam; sell direct. (Buy yarns.)
- PAOLI BLEACH WORKS;** J. H. Robinson, (**H**) prop.; Umbria St and Paoli Ave; Manu-yarns; Robt. Nuttall, supt.; Bleach Yarns, Turkish Towels, Webbing, Underwear and Warps; steam
- PARKER, JOHN, MFG. Co.** Purchased by J. Ellwood Lee Co. *Conschockton, Pa.*
- PARKINSON, EDW;** 106 Garfield St, Ger. (**K**) mantown; Knit Gloves; buy woolen and worsted yarns; 18 knitting machines; sell direct.
- PARSONS, WM;** 4035 Orchard St; (**C** & **W**) Frankford; Map E; Sq. 80; Cotton and Woolen Waste; 1 willow; Wm. Parson, buyer.
- PATTERSON, MFG. Co;** N. W. cor. (**C** & **J**) 8th and Dauphin Sts; Map A; Sq. 61; Hammocks, Lenos and Cotton Goods; 32 looms; steam; sell direct; J. B. Patterson, buyer.
- PAYTON, ALBERT J.** 163-167 West (**Pr** & **F**) Oxford St; Hosiery Finishing and Printing; steam; capacity 1500 doz. per day.
- PEBERDY, GEO;** Wingohocking Hosiery (**K**) Mills; Penn St; Germantown; Map D; Sq. 91; Cardigan Jackets, Hosiery and Sweaters; 337 knitting machines; steam; sell direct; Chas. Peberdy, buyer.
- PEEL, ROBERT;** 4155 Frankford Ave. (**K**) Frankford; Map C; Sq. 71; Hosiery.
- PEERLESS SILK DYE WORKS;** Hatty (**D**) Brewin, prop. and mgr; office 1845 Willard St; Willard and Jasper Sts; Skein Silk Yarn Dyeing.
- PENDELBURY, S. & SON;** Ara (**D** & **Pr**) mingo Dyeing, Finishing and Printing Works; Buckius Lane; Frankford; Map E; Sq. 80; steam; dye; S. Pendlebury, buyer.
- PENN ARTISTIC WEAVING Co.** (formerly (**S**) at Egg Harbor City, N. J.); Waterloo and York Sts; Map C; Sq. 62; Geo. J. Newman, supt.; Coat Labels and Coat Hangers; 14 looms; steam; sell direct.
- PENN KNITTING Co;** 1116-1126 Mont. (**K**) gomery Ave; Map C; Sq. 53; Ribbed Underwear, Union Suits, Cotton, Lisle and Worsted and Knitted Skirts; steam; sell direct.
- PENN WORSTED Co;** Howard and Jeffer. (**W**) son Sts; Map C; Sq. 54; \$20,000; H. R. Sack, pres. and supt; Wm. Messner, treas.; Worsted Goods, Men's Wear; 16 looms; steam; Nostrand & Moore, s. agts.

- PENNANT KNITTING CO.** *Removed to* (**K**) *Shepherdstown, W. Va., which see.*
- PENNYPACK YARN FINISHING CO;** (**F**) Holmesburg; H. C. Forrest, pres.; J. C. Forrest, treas.; E. E. Forrest, sec.; Mercerizers and Finishers of Yarns.
- PEQUEA MILLS;** 22nd and Spring Gar. (**W**) den Sts; Map A; Sq. 44; Worsted and Woolen Men's Wear, Cheviots, Cassimeres, etc.; (about 50 sets and 800 looms); steam; dye; Wm. Wood & Co, Phila, N. Y. and Chicago, s. agts.
- PERRY, FERGUS;** 5013 Wakefield St.; (**S**) Germantown; Map D; Sq. 82; Elastic Cord; dealer in Silk and Cotton Binding; 5 covering machines; steam; sell direct.
- PETERSON, GEO. W;** agt. Manayunk Fin. (**F**) ishing Works; Ripka Mills; Main St; Map F; Sq. 73; Finisher Cotton, Woolen and Worsted Fabrics; steam; G. W. Peterson, buyer.
- PETZOLDT, H. & SONS;** 2214 Frankford (**W**) Ave; Map C; Sq. 62; Rag and Cottage Carpet; 12 looms; hand power; sell direct; H. Petzoldt, buyer. (Buy 8/2s, 8/3s and 4/4s cotton yarn and 3 ply wool.)
- PETZOLDT, L. H;** Howard and Berks (**W** & **C**) Sts; Map C; Sq. 54; P. O. address, Station O; Wool and Cotton; 17 looms; steam; sell direct.
- PHILADELPHIA DYE WORKS;** W. E. Knipe; (**D**) Hancock, below Berks Sts; Map C; Sq. 54; Dyers of Cotton, Woolen and Worsted Yarns; steam.
- PHILADELPHIA HOSIERY FINISHING (F**) WORKS; Max Leithold, prop; 3211 Frankford Ave; Finishers of Hosiery; steam.
- PHILADELPHIA KNITTING MILLS CO;** (**K**) 16th and Indiana Ave; Map A; Sq. 61; \$100,000; Wm. H. Bilyer, pres; Chas. Möller, supt; Cotton and Silk Hosiery; 50 full-fashioned knitting machines; steam; sell direct; Chas. Möller, buyer.
- PHILADELPHIA LINEN CO.** Plant purchased by and consolidated with Aransca Mfg. Co., which see.
- PHILADELPHIA TAPESTRY MILLS;** A1. (**C** & **S**) Iegheny Ave. and Front St; Map A; Sq. 70; J. Wasserman, pres; T. Wasserman, treas; John Zimmerman, supt; Upholstry Fabrics, Hair Cloths, Turkey Red Damask, Linen Piece Goods; 210 looms; steam; sell direct; John Zimmerman, buyer.
- PHILADELPHIA TEXTILE SCHOOL;** (**C** **W** & **D**) Broad and Pine Sts; Map B; Sq. 36; T. C. Search, pres; Robt. K. McNeely, treas; E. W. France, director; Carding, Spinning and Finishing, Chemistry and Dyeing.
- PHILADELPHIA THREAD CO.** (successors **C**) to Camden Thread Co.; N. E. cor. Hancock and Oxford Sts; Map C; Sq. 54; D. H. McKinley, mgr; Glazed Threads; steam; sell direct.
- PHILADELPHIA TRUSS CO;** 610 Locust (**K**) St; Map B; Sq. 37; Surgical Hosiery, Springs, Suspensory Bandages, Crutches and Trusses; 8 knitting machines; 10 h. p. gas engine; sell direct; H. Becker, buyer. (P. O. box 1207.)
- PHILADELPHIA WORSTED CO.** *See Camden, N. J.*
- PHENIX MILLS CO;** Ltd.; Cotton St. Manayunk (Campbell Mill); Fine Worsted Yarns (Bradford System); 20 sets; 13 combs; 30 spinning frames; 13,000 spindles; steam. *Not running. Reported to be sold May, '02.*
- PILLING & MADELEY;** Trenton Ave. and (**K**) Huntington St; Map A; Sq. 62; Men's and Boy's Ribbed Hose; steam; dye; Shreve & Adams, N. Y., s. agts; Mr. Pilling, buyer.
- PILLING MFG. CO;** Trenton Ave. and (**K**) Ann St; Map A; Sq. 62; (P. O. address, Station E); Ladies' Ribbed Underwear; steam; dye; Shreve & Adams, N. Y., s. agts; A. B. Anderson, buyer.
- PINE TREE SILK MILLS CO;** (successors **S**) to Franklin Silk Mills); 1th and Cumberland Sts; Map C; Sq. 62; Garrett V. Clark, pres; Morris Dannenbaum, treas; Edwin M. Dannenbaum, sec; John Best, mgr; Specialists in Artistic Weaving; 15 looms; sell direct.
- PLATT BROS;** Main St, Manayunk; Map (**W**) F; Sq. 73; Carpet Yarns; 2 sets; steam; sell direct. (In old Lincoln Mill.)
- PLATT, A. & SON;** Main St; Mana- (**W** & **C**) yunk; Map F; Sq. 73; A. C. Platt, supt; Cotton, Woolen and Merino Yarns; 6 sets; 10,000 cotton spindles; steam; dye; sell direct; office, 246 Chestnut St; A. Platt, buyer.
- POLLITZ, KAUFMAN & CO;** 1716 N. 5th (**C**) St.; Irish Point Lace Curtains, Tamboured Muslin-Ruffled Curtains, Summer Lap Robes. (Buy fine cotton yarns.)
- POLLOCK, JAS;** Oxford and Jose. (**C** & **W**) pline Sts; Frankford; Map E; Sq. 80; Cotton and Woolen Goods; 82 looms; steam; James Talcott, N. Y., s. agt; Jas. Pollock, buyer.
- POLLOCK, JAMES, & SON;** Dauphin and (**W**) Tulp Sts; Map C; Sq. 62; Dauphin Mills; Ingrain, Granite and Venetian Stair Carpets; 50 looms; steam; Frank Littlefield, 82 White St, N. Y., M. H. Jordan, Chicago, s. agts; James Pollock, buyer.
- PORTER & DICKEY;** Howard and Nor. (**C**) ris Sts; Map C; Sq. 62; Chas. Porter, Jr, mgr; Men's Wear and Fancy Worsted Dress Goods; 350 looms; steam; Wm. Iselin & Co. and A. D. Juilliard & Co, s. agts; Chas. Porter, buyer. (Buy woolen and worsted yarns.)
- POSERN, H;** 1808 South St; Map A; (**W** & **K**) Sq. 28; Rag Carpets, Hand Knit Jackets and Hosiery; 1 loom; 1 knitting machine; sell direct; H. Posern, buyer.
- POWELL & BRO;** 28th and Parish Sts; (**K**) Map A; Sq. 44; G. J. Graff, supt; Seamless Hosiery; 800 knitting machines; 250 looping machines; 25 sewing machines; steam; dye; Wm. Powell, 43 Leonard St, N. Y., Messrs. Graff and Snodgrass, buyers.
- PRINCE, S. L;** Jasper and Huntingdon (**W**) Sts; Map C; Sq. 62; W. Prince, supt; Plain and Novelty Dress Goods; 50 broad looms; steam; sell direct; Geo. Prince, buyer; office 2722 Hope St.
- PROVIDENCE MILLS MFG. CO;** 55th St. (**B**) and Girard Ave; Map C; Sq. 53; \$100,000; Benjamin Bell, pres.; Bleachers Damasks and Crashes; steam.
- QUAKER CITY DYE WORKS CO;** 110 Ox- (**D**) ford St; Map C; Sq. 54; \$400,000; Chas. H. Salmon, pres; C. M. Latonrette, treas; H. B. Latta, sec; W. S. Wright, supt; Dyers and Finishers of Cotton Piece Goods; steam.
- QUAKER CITY KNITTING CO.** *See Woodbine, N. J.*
- QUEENS BROS;** 1916 No. 4th St; Victoria (**K**) Knitting Mills; Map C; Sq. 61; Ladies', Men's and Misses' Underwear; 130 knitting machines; steam; dye; Critten, Clift & Co, 48 Leonard St, N. Y., s. agts; firm, buyers. (Buy yarn.)
- RAILEY, A;** Brighton Mills; 105 (**W** & **J**) Columbia Ave; Sam'l White, mgr; Wool Smyrna Rugs and Jute Smyrna Rugs and Carpets; 90 looms; steam; Geo. E. Allen, 95 Franklin St, N. Y., s. agt.
- RANDALL, JOSEPH, & BRO;** Franklin (**W**) Yarn Mills; 102 East Sharpnack St; Station G; Germantown; Map D; Sq. 99; Woolen and Merino Yarns (Belgian system), also Colored Yarns and Mixes; 3040 spindles; 5 sets; steam; sell direct; J. Randall, buyer.
- RATH, H, JR;** 5th and Columbia Ave; (**W**) Map C; Sq. 53; Ingrains; 21 looms; steam; sell direct; H. Rath, Jr, buyer.



- READ, ED. C.; Hope above Lehigh Ave; (W Map A; Sq. 61; Ingrain Carpets; 50 looms; steam; sell direct; E. C. Read, buyer. (Buys worsted, wool and cotton yarns.)
- READ, WM. F.; Victoria Mill; So. (W & S 12th and Jackson Sts; Map A; Sq. 29; John D. Phillips, supt; Silk and Wool Dress Goods; 275 looms; steam; sell direct; office, 209-11 Chestnut St; N. Y. salesroom, 487 Broadway. (Buy fine worsted and woolen yarns.)
- REID, GRAHAM & CO.; Howard and (K Berks Sts; Seamless Hosiery; 200 knitting machines; Staley & Co, s. agts.
- RHINSTROM, B. A.; 176 West York St.; (S Mercerized and Silk Braids; 25 braiding machines; steam; Geo. W. Chapin, Phila., s. agt.
- RHODES, WM. & SON. See Rhodesia (W Map C, (Inc.).
- RHODESIA MFG. CO. (Inc.); Howard and (W Huntingdon Sts; Map C; Sq. 62; \$25,000; Thos. F. Rhodes, pres; Wm. Rhodes, treas; Thos. F. Rhodes, supt. and buyer; Wool and Worsted Fabrics; 30 looms; steam; Francis R. Masters & Co, s. agts.
- RICE, CLAYTON G.; Harmony Mills; (C & W Walnut Lane; Manayunk; Map F; Sq. 73; Cotton, Woolen and Merino Yarns; 6 sets; 6000 spindles; steam; dye; sell direct; C. G. Rice, buyer.
- RICKER & LOGAN; 2411 Howard St; (W Map C; Sq. 62; Ingrains; 53 looms; steam; sell direct.
- RINEHART, H. P.; Adams and Emerald (W Sts; Map C; Sq. 62; Wool and Merino Yarns; 2 sets; steam; sell direct; H. P. Rinehart, buyer.
- RING, JONATHAN, & SON; 1759 Hancock (W St; Map C; Sq. 54; Woolen and Merino Yarn; 7 sets; steam; sell direct; J. Ring & Son, buyers.
- RITCHE, ROBT. J. & R. CO; 4080 Orchard (S St, Frankford; \$60,000; W. H. Burns, pres; Jas. Bromiley, treas; Robt. Ritchie, mgr; Chenille Curtains; 90 looms; (75 power); steam; sell direct; Jas. Bromiley, buyer; salesroom, 119 Worth St, N. Y.
- ROBERTSHAW, A. L., Co., THE; Berkeley (W St. and Wayne Ave; Mr. Longbottom, pres.; Mr. Levin, treas.; J. H. Salmon, supt.; Fancy Worsteds for Men's Wear; 50 looms; steam; sell direct; A. L. Robertshaw, buyer.
- ROELOFS, HENRY H. & Co; 12th & (W Brown Sts; Soft and Stiff Felt Hats; steam; dye; sell direct; H. Roelofs, buyer.
- ROGERS, WM. & Co; 1720 N. 2d St; Map C; (S Sq. 54; Chenille, Tapestry, Silk and Mercerized Curtains, Covers and Piece Goods; 20 looms; steam; W. E. Rosenthal N. Y., s. agt; Mr. Rogers, buyer.
- ROOSEVELT WORSTED MILL; 21st and (W Naudain Sts.; \$10,000; Curt A. Loewel, pres; Oscar Hoffstadt, treas.; S. K. Loucheim, sec; Wm. Deacon, supt; Worsted Yarns; 3400 spindles; 3 combs; steam; sell direct; O. Hoffstadt, buyer.
- ROSE, JAMES & SON; Willard St, below (W Kensington Ave; Smyrna Rugs; Table Covers; 15 looms; sell direct; James Rose, buyer.
- ROSENAU & LOEB; Liberty Hosiery (K Mills; Mascher, above Oxford St; Seamless Hose and Half Hose; 300 knitting machines; steam; sell direct; Arthur Loeb, buyer. (Buy 20s cotton yarns.)
- ROSENAU, S. & CO; (formerly Lazarus, (S Schwarz & Co.); 445 Darien St; Map B; Sq. 45; Dress and Millinery Trimmings and Braids; (buy yarns); 65 looms, 20 knitting machines; salesroom 467 Broadway, N. Y.
- ROSENHEIM, Bros. & Co; 62nd St. and (C Girard Ave; Map C; Sq. 54; Upholstery Goods; 18 looms; sell direct. (Buy cotton and mercerized yarns.
- ROXBORO MILLS Co; Freeland Ave. (D & H and Walnut Lane; Dyers of Yarns and Raw Stocks; steam.
- ROXFORD KNITTING Co; (P. O. address, (K Fairhill Station); works at Lehigh Ave. and Front St; Map A; Sq. 62; \$250,000; H. Schloss, pres; J. Feldeheimer, treas; A. M. Roedelheim, sec; Men's Cotton Bulbriggan Underwear; 150 knitting machines; steam; dye; sell direct; pres; and treas, buyers; N. Y. office, N. Y. Life Bldg, R. 926. (Buy Yarns.)
- RUTHOLT DYE WORKS; See Wm. Wood & (D Co.
- SARANAC MILLS; The J. Caven Co; 15th (S and North Sts; Map B; Sq. 44; \$100,000; James Caven, pres; F. H. Caven, treas; Upholstery, Webbing, Piece Goods and Shade Trimmings; 100 looms; steam; sell direct; F. H. Caven, buyer; salesrooms, 33 Union Sq., N. Y., and 76 Chauncey St. and 26 Phillips Bldg., Boston; 24 Adams St., Chicago.
- SARFERT, MAX; Germania Dye Works; (D Kensington and Allegheny Aves; Map C; Sq. 71; Dye Cotton and Silk-alene Yarns, Hosiery and Webbing; steam.
- SACQUOIT SILK MFG. CO; Randolph St. (S corner Columbia Ave; 189 looms; steam. (See also Bethlehem and Scranton, Pa.)
- SAXON DYE WORKS; Richard Myer (D and Walter Beatty; Richmond & Kettlewell Sts; Map C; Sq. 54; Dyer.
- SAXONIA DRESS GOODS MILLS; Howard (W & Palmer Sts; Map C; Sq., 84; \$200,000; Henry W. Steinhauser, pres; Alfred Thiele, treas; Fred. Eick, supt; Fancy Dress Goods and Woolens; 40 looms; S. Peierls & Co., s. agts.
- SCANLIN, JOHN, & SON; Howard Mill; (W S. E. cor. 3rd and Huntinglon Sts; Map A; Sq. 61; J. W. Patterson, supt; Dress Goods, Cheviots, Shirtings, Madras Cloths; 260 looms; steam; Wilson & Bradbury, and Francis R. Masters, & Co, s. agts; office, 140 Chestnut St; Jas. Kitchenman, buyer. (Buy coarse and fine cotton yarns.)
- SCARBOROUGH MFG. CO; Jos. Cul. (C & W bert, agent; Howard and Jefferson Sts; Map C; Sq. 54; Checks, Flannels, Ginghams and Dress Goods; 410 looms; steam; sell direct; Jos. Culbert, buyer.
- SCATCHARD'S, JOSEPH, SONS; Chelton (W and Magnolia Aves; Germantown; Map D; Sq. 91; Woolen and Merino Yarns; 12 sets; steam; dye; sell direct.
- SCHADEWALD, HENRY; Lehigh Ave; (C Fairhill; Station Q; C. F. Schadewald, overseer; W. F. Schadewald, mgr; H. M. Schadewald, supt; Cotton Spinning, Bed Spreads, Table Covers, Mitchelline Quilts, Coverlets and Towels; 9,000 spindles; 178 looms; dye and finish; steam; sell direct and Andrew A. Wood & Co., N. Y., s. agts; H. M. Schadewald, buyer. (Buy 20/1, H/3, 12/2 warps and 8/2 skein.)
- SCHANZ, FRANK; Lehigh Dye Works; (D (formerly R. Pause & Co.) 2719 Germantown Ave; Worsted, Woolen and Merino Yarns.
- SCHUCK & GOODMAN; Kingston Mills; (W Palmer & Howard Sts; Map C; Sq. 54; Joseph Bauer, supt; Granite Ingrains and Damask and Venetian Stair Carpets; 15 looms; steam; sell direct; firm, buyers. (Buy 2/14s cotton yarn, 150 yard wool yarn and 11 lb. jute yarn.)
- SCHERR Bros; Penn. Silk Mills; N. W. (S cor. 2nd & Norris Sts; Map C; Sq. 62; Ribbons; 70 looms; steam; E. Scherr, buyer.
- SCHLATTER & SAKS; 460 N. 12th St; Dress (S Trimmings; 30 looms; steam; sell direct; N. Y. office, 29 Mercer St; H. M. Sacks, buyer.

- SCHLICHTER JUTE CORDAGE CO, THE;** 23 (J) N. Front and Erie Sts. and Trenton Ave.; Map B; Sq. 45; \$500,000; Isaac Schlichter, pres.; W. H. Heister, treas.; Edmund Dawcs, supt; Cordage and Twine; 10 sets machinery; steam; sell direct.
- SCHMIDT, GEO. & BRO;** Nicetown Ho. (K) siery Mills; Dell and Luzerne Sts.; (P. O. address, Station R); Ladies', Men's and Misses' Fancy and Seamless Hosiery and Ladies' Underwear; 114 knitting machines; steam; sell direct; Geo. Schmidt, buyer.
- SCHOFIELD, ALBERT E.** See Delph Spinning Co.
- SCHOFIELD, MASON & CO;** Delaware Car. (W) pet Mills; Cumberland, above 5th St; Map A; Sq. 61; Wilton and Body Brussels, Wilton Rugs and Carriage Carpets; also Furniture Coverings; 90 looms; steam; dye; sell direct; T. P. Rider, buyer.
- SCHOLES, WM.;** Wayne Junction; In- (W) grains and Art Squares; 40 looms; steam; sell direct. (Buy 14/2 ply worsted and cotton, 5/6 double reel cotton and wool.)
- SCHOLES, WM. & SON;** 2nd and Indiana (W) Sts; Map A; Sq. 61; Wool, Worsted and Carpet Yarns; 12 woolen and 2 worsted sets; 4 combs; 1800 spindles; steam; sell direct; members of firm buy.
- SCHRACK & SHERWOOD;** 235 Market St; (S) Map B; Sq. 45; H. C. Lees, supt; Upholstery Trimmings; 27 looms; steam; W. E. Rosenthal, 142 5th Ave, s. agt; Mr. Schrack, buyer.
- SCHULTZ MFG. CO.;** 1223 1229 Callowhill St; (S) Map B; Sq. 45; Broad Silks, Tailors' Trimmings and Dress Goods; 30 looms; steam; Cozzens, Elbers & Frankard, 472 and 474 Broome St, N. Y., s. agts; Geo. H. Schultz, buyer.
- SCHWARZWÄELDER CO, THE;** 301-303 (F) Cherry St; Map B; Sq. 45; \$23,700; S. H. Hicks, pres.; E. F. Lukens, treas.; H. M. Dammann, supt; Spongers, Examiners and Refinishers; steam; sell direct.
- SCHWEIM, JNO. M. & SONS;** 13-25 (W & S) Wister St; Germantown; Map D; Sq. 92; Hair Cloths and Press Cloth, Tailors' Silk Linings, Upholstery Goods; 300 looms; steam; dye; sell direct; firm, buyers.
- SCHWEIGART, J.;** American Dye Works; (D) Treigant Ave. and Lippincott St; Richmond District; Cotton Yarns; steam; dye.
- SCOTT, DANIEL;** Wistar St; German (W) town; Map D; Sq. 92; Harry Scott, supt; Woolen Waste; 1 picker; 1 willow; steam; sell direct; Dan'l Scott, buyer.
- SCOTT, J. WILSON & CO;** 2013 Arizona (C & K) St; Harness Twines and Ladies' Cotton and Lisle Seamless Hosiery; sell direct.
- SECKINGER, L. & SON;** 1206 Day St; Map (W) C; Sq. 54; Rag Carpets; 4 looms; hand power; sell direct; firm, buyers.
- SEFFARLEN, JOSEPH A. & CO;** 427 Market (W) St; Map B; Sq. 45; Warps for Rag Carpets; electric; Mr. Seffarlen, buyer.
- SEIDMANN, DAVID & SONS MFG. CO.;** 234 (S) N. Second St.; J. C. Seidmann, supt.; Fringes, Loops, Tassels, etc.; sell direct and through agents. (Buy cotton, woolen and silk yarns.)
- SHACKAMAXON WORSTED CO.** See J. R. Keim & Co.
- SHARKEY WILLIAM M.;** Girard Carpet (W) Works; 227 East Girard Ave; Yard Wide Reversible Brussels Carpet; 12 looms; hand power; sell direct; W. M. Sharkey, buyer. (Buy worsted and jute yarns, different sizes.)
- SHAW & BOWEN;** Crompton Mills; Main (W) St, foot Washington; Manayunk; Map F; Sq. 73; Wool Spun Yarns; 4 sets; 2160 spindles; steam; dye; sell direct; firm, buyers.
- SHAW, JOSEPH;** Dyre St. near Willow; (W) Shoddy and Waste; steam.
- SHEBLE, FRANK J.;** (formerly William (W) Dalton); (Station E); E. Thompson and Division Sts; Map C; Sq. 63; All Wool and Fine Merino Yarns, from 10 to 40 cuts; 3,000 spindles; 4 sets; steam; sell direct.
- SHELMIRE & BROWNHILL;** 2120 E. Dakota (K) St; Ladies' Hosiery and Half Hose; 42 knitting machines; 7 ribbers; 5 loopers; 2 sewing machines; John M. Given, s. agt; J. W. Shelmore, buyer. (Buy carded Peeler, Nos. 9-11, 13-16 and 40.)
- SHORT, W. F.;** Crescent Hosiery Mills; (K) 3016 E. Thompson St; Richmond; Map C; Sq. 63; J. W. Short, supt; Wool and Merino Hosiery; 160 knitting machines; steam; dye; sell direct; W. F. Short, buyer.
- SIBSON & STERN;** Germantown; Edg. (K) ings and Laces for Ladies' Underwear; 18 lace machines; steam; sell direct.
- SICER, HENRY;** 2115 Arizona St; Rag (W) Carpets; 15 looms; hand power; sell direct; H. Sicer, buyer.
- SIDEBOTHAM, JOHN, B.;** Langdell Mill; (C) 4318 Frankford Ave; Frankford; Map E; Sq. 80; Tapes and Narrow Fabrics; 90 looms; steam; bleach; Wright & Graham, 13 White St., N. Y., s. agts; Jno. B. Sidebottom, buyer. (Buys 2 ply cotton yarns.)
- SIMISTER, CHAS. R.;** Picton Mills; Man. (W) ayunk; Map F; Sq. 73; Sam C. Blakeley, supt; Shoddy, also scouring and Extracting; 6 cards; 7 pickers; steam; dye; sell direct; Chas. R. Simister, buyer.
- SIMONS & STRUVE HOSEIERY CO.** (for (K) meryl Simons & Baxindine); Rialto Mills; Elizabeth and Unity Sts; Frankford; Map E; Sq. 80; Cotton and Cashmere Cut and Seamless Hosiery; 200 knitting machines; steam; dye; sell direct. (Buys 16s to 20s cotton yarns.)
- SIMPSON BROS.;** Wabash Mills; (C, W & S) Manayunk; Map F; Sq. 73; Cotton, Woolen, Worsted and Silk Goods; 132 looms; steam; Cooley, Turnbull & Co, s. agts.
- SMALLEY, HARRY R.;** Centre Hosiery (K) Mills; 1113 E. Rittenhouse St; Germantown; Map D; Sq. 91; Cut and Seamless Hosiery; 200 knitting machines; steam; F. B. Berlin, 43 Leonard St, N. Y., s. agt; Harry R. Smalley, buyer.
- SMITH, JNO.;** Turner and Mascher Sts; (W) Map C; Sq. 54; Ingrains; 17 looms; steam; Smith & Stahl, Chicago, s. agts; also sell direct; John Smith, buyer. (Buy carpet yarns.)
- SMITH, JOSEPH;** 3045 N. 5th St; Cotton (C) Bunting; 4 looms; steam; sell direct; Joseph Smith, buyer.
- SMITH, JOS. T.;** Emerald St. and E. Alle. (W) gheny Ave; Map E; Sq. 71; Worsted Drawing and Spinning; 3,000 spindles.
- SMITH, OSCAR & SON;** 1310 Lawrence St.; (C) Cotton Felts and Batts for Bedding and Upholstering Purposes; 1 card; 4 Garnetts; sell direct; A. T. Smith, buyer.
- SMITH, THOS.;** Orthodox and Race Sts; (D) Frankford; Map C; Sq. 80; Dyers of Cotton and Woolen Yarns.
- SMITH, W. T. & SON;** 3rd St. and (W & C) Lehigh Ave; Map A; Sq. 61; Smyrna Rugs and Carpets, Chenille and Lace Curtains; 275 looms; steam; sell direct; N. Y. office, 29 Union Square.
- SOMERSET & CO.;** Keystone Mill; Wilde (W) St. and Leverington Ave; Manayunk; Map F; Sq. 73; Carpet Yarn; 5 sets; steam; sell direct; Wm. Somerset, buyer.
- SOUTHERN WASTE WORKS (LTD).;** (C & W) 16th and Carpenter Sts; Map B; Sq. 36; \$22,000; C. L. Hagy, chairman; C. L. Hagy, Jr. see; J. H. Blye, treas; White and Colored Cotton and Woolen Waste; steam; sell direct; C. L. Hagy, Jr, buyer.

- SOUTHWARK MILLS CO, THE;** 15th and (W) Wharton Sts. and 8th and Tasker Sts.; Map A; Sq. 29; \$350,000; Jas. Brown, pres.; C. A. Furbush, vice-pres.; J. R. James, treas.; John Burt, sec.; Luke Page, supt.; Dress Goods and Cloakings; 24 sets; 470 looms; steam; dye; John Burt and Fred Viofor & Achelis, N. Y., s. agts.; office, 674 Phila. Bourse; John Burt, buyer.
- SOUTHWARK MILLS CO;** Ripka Mills; (W) Manayunk; Map F; Sq. 73; Woolen Yarns; 4 sets; 1776 spindles; water. (Manufacture yarns for plant at 8th and Tasker Sts.)
- SOUTHWARK MILLS CO, THE;** Mill No. 4; (W) (See main office 8th and Tasker Sts.); 4800 spindles; 7 sets; 216 looms; steam; dye. (Formerly Dingley Mfg. Co.)
- SOUTHWARK MILLS CO, THE;** (See main (W) office at 8th and Tasker Sts.); Continental Worsted Mills; Mill No. 5; So. 21st St. and Washington Ave.; Map A; Sq. 28; Worsted Yarns, all numbers and grades; (French, German and English systems); 54 combs; 25,000 spindles; steam.
- SPAINGTHORPE, ISAAC** (Estate of); 4971 (K) Wakefield St.; Germantown; Map D; Sq. 92; Knit Goods, Ladies' Waists and Shetland Shawls; 12 knitting machines and 14 sewing machines; steam.
- SPENCER & CHATTERTON;** 5817 Walker St.; (C) (Wisconsining); Table Damask; 16 looms.
- SPINK, WM;** Sciota Mill; Mana. (W & D) yunk; Map F; Sq. 73; Wool Extracts, Carbonizing, Custom Dyeing; 2 cards; steam and water; dye; sell direct; Wm. Spink, buyer.
- SPROWLES, J. H. Co., THE;** Wayne June. (K) Map C; Sq. 63; \$20,000; Geo. E. Saul, pres.; J. H. Sprowles, treas.; Hosiery, All Grades; 146 knitting machines; 16 loopers; 5 sewing machines; steam; sell direct; J. H. Sprowles, buyer. (Buy 1½ to 50 single Egyptian and Peeler yarn.)
- ST. LEGER MILLS;** Inc; (successors to (W) Olivette Mills); 62d St. and Baltimore Ave.; \$100,000; Geo. A. Rice, pres. and supt.; Piece Dyed Clays and Flannels; 5 sets; 170 looms; steam; dye; Dickson, Peck & Palmer, s. agts.
- STAFFORD & Co;** Little Falls Mills; (W) Kraus Ave.; Manayunk; Map F; Sq. 73; Carpet and Cloaking Yarns and Blankets; 10 sets; 20 looms; steam; finish; sell direct; firm, buyers.
- STAFFORD'S SONS, JAS;** Star Woolen (W) Mills; Kraus Ave.; Manayunk; Map F; Sq. 73; Blankets, Linings and Robes; 6 sets; 42 broad looms; steam; dye; sell direct.
- STANDARD EAST BLACK DYE WORKS;** (D) 3211 Frankford Ave.; Wm. McFarland, supt.; Dyeing Cotton Yarns and Hosiery; Julius Leithold, buyer.
- STANDARD HOSEIERY CO;** \$50,000; 1212 (K) Crease St.; Map C; Sq. 54; Children's Cotton Fast Black Ribbed Hose; 300 knitting machines; steam; dye; sell direct; D. Berlzheimer, buyer.
- STANDARD KNITTING MILLS;** Joseph (K) L. Behal; 147-151 N. 10th St.; Map A; Sq. 45; Ladies' Ribbed Underwear and Knit Skirts, Cotton Wool and Mixed; 28 knitting machines; steam; sell direct.
- STAR & CRESCENT MILLS CO;** Hancock (C) and Lehigh Ave.; Map A; Sq. 61; \$200,000; Frank Leake, pres.; Douglas Leake, sec. and treas.; J. S. Davis, supt.; Turkish Towels, Tildies, Terry Cloth, Pile Fabrics; 220 looms; steam; bleach house; sell direct; salesrooms, 83 Leonard, N. Y.; and 700 Arch St., Phila.; Douglas Leake, buyer. (Also Ripka Mills, Manayunk; Piece Goods, Shirts, Etc.; 180 looms.)
- STARRELS, M;** 114 So. 2d St.; Wool and (W) Worsted Cardigan Jackets, Sweaters, Tam O'Shanter Novelties in Headwear, Etc. 20 knitting machines; steam; sell direct;
- Mr. Starrels, buyer. (Buy 2/12 soft twist and 2/6 white or colored on cones.)
- STEAD, MILLER & Co;** dye house; (S & D) American, above Huntingdon St.; Mill at 4th and Cambria Sts.; Map A; Sq. 61; Arthur S. Milnes, supt.; Draperies and Upholstery Goods; also Dyers; 100 looms; steam; sell direct; Miller and Stead, buyers, N. Y., office 33 Union Sq.
- STEELE & LANEY;** 2124 E. Dakota St.; (C) Cotton and Silk Machine Wipers; Scrub Cloths, Etc; 5 looms; steam.
- STERLING CARPET MILLS;** Tacony St. (W) and P. RR.; Wm. A. McElroy, mgr.; Mr. Harris, supt.; Willon Velvet Carpets, Worsted and Mohair Yarns; 10 sets; 200 looms; sell direct.
- STETSON CO, JNO. B.;** 4th St. and Mont. (W) gomery Ave.; Map C; Sq. 53; \$3,000,000; Jno. B. Stetson, pres.; W. P. Fray, 1st vice-pres.; J. Howell Cummings, 2d vice-pres.; Wm. K. Kripps, treas.; Henry E. Deputy, sec.; Soft and Stiff Felt Hats; steam; dye; sell direct.
- STIEF, H. M. & SON;** 110-116 Noble St.; (C) Map B; Sq. 45; Hammocks, School Bags and Fancy Goods; 15 looms; 16 sewing machines; steam; sell direct; H. M. Stief, buyer. (Buy 8/4-8/3 cotton; Nos. 6-9-12 seine twines.)
- STINSON BROS;** Huntingdon, above 5th (W) St.; Map A; Sq. 61; Tapestry and Velvet Carpets; 96 looms; steam; sell direct; firm, buyers.
- STOCKTON BROS;** 2109 N. 2nd St.; Map C; (K) Sq. 62; Rib and Seamless Half Hose and Fancy Hosiery; 41 knitting machines; steam; sell direct; D. J. Stockton, buyer.
- STRAFFORD KNITTING MILLS;** Wm. S. (K) Lloyd, prop.; Wayne Junction, Germantown; Robt. Patterson, supt.; Ladies' Worsted and Worsted-plated Knit Underwear; 70 knitting machines; steam; E. M. Townsend & Co., N. Y., s. agts. (Buy 98 and 2/45 cotton, 20s and 40s worsted and merino yarn.)
- STROUD, DAVID H.;** Enterprise Mills; (W) Marshall and Juniata Sts.; Nicholas Albrecht, supt.; Chemille, Tapestry Curtains and Covers, and Symrna Rugs; 80 looms; steam; sell direct and P. J. Donovan & Co., s. agts.; D. H. Stroud, buyer.
- SULLIVAN, J. & SONS MFG. CO;** 9th and (C) Susquehanna Ave.; also Chicago; Map A; Sq. 61; \$500,000; James J. Sullivan, pres.; H. J. Sullivan, treas.; Narrow Fabrics; 500 looms; steam; dye; Porter Bros. & Co., N. Y.; E. H. Wangelin & Co., St. Louis, s. agts.; James J. Sullivan, buyer.
- SULLIVAN, WM. & CO;** Oxford Ho. (W & K) siery Mill; 2nd and Somerset Sts.; Map A; Sq. 51; Men's Worsted Wear and Hosiery; 21 looms; 250 knitting machines; steam; sell direct; Wm. Sullivan, buyer.
- SULTAN TEXTILE MILLS;** Palethorp and (C) Hancock Sts.; Map C; Sq. 54; Frank Krewson, prop.; Cotton Damask Table Covers; 22 looms; Whitman & Phelps, s. agts.
- SUMMERDALE DYEING, PRINT. (D. Pr & B) YING AND FINISHING WORKS** (Holmesburg); E. P. Rank, atty; Jonas Eberhardt, supt.; Cotton Piece Goods, Dyed, Bleached, Printed, etc.; steam and water.
- SUMNER, THOS. & SON;** 1926 E. Boston (C) Ave.; Damask; 11 looms; steam; sell direct.
- SUTRO, E. & SON;** Richmond Hosiery (K) Mills; Thompson and Clearfield Sts.; Map C; Sq. 63; Michael O'Brien, supt.; Cotton, Cut and Seamless Hosiery; 400 knitting machines; steam; dye; sell direct; Paul E. Sutro, buyer.
- SUTRO, E. & SON;** Indelible Dye Works; (D) 3140 Edgemont St.; Map C; Sq. 71; East Black, Tan and High Color Dyeing, also Extracting and Fancy Colorings on Hosiery; steam; Paul E. Sutro, buyer.

- SWIRE & SCOTT; Rook Carpet Mills; 111 (W** Huntingdon St; Map C; Sq. 62; Ingrain and Art Squares; 63 looms; steam; sell direct; Wm. Scott, buyer.
- SYKES, D; 2080 East Dauphin St; Map C; (W** Sq. 62; Waste; 2 sets; 1 picker; 1 puller; 1 willow; steam; sell direct; D. Sykes, buyer.
- SYKES BROS; Hancock and Huntingdon (W** Sts; Map A; Sq. 61; Carpet Yarn; 14 sets; steam; sell direct; Sykes Bros, buyers.
- TAYLOR & SCOTT; Globe Mills; 2627 Nut- (C** ter St.; T. Taylor, supt.; Damask; 13 looms. (Buy 19 and 20 yards.)
- TAYLOR, HERBERT G; 1809 Russell (B1 & F** St; Bleaching and Finishing of Cotton Goods.
- TAYLOR, JOSEPH & SON; Star Carpet (W** Mill; Montgomery Ave. and Howard St; Map C; Sq. 54; All-wool Ingrains; 81 looms; steam; dye; sell direct; Joseph Taylor & Son, buyers.
- TAYLOR BROS; 84 Mill St; Germantown; (W** Map D; Sq. 91; Shoddy; 5 pickers; 7 garnet machines; steam; sell direct.
- TAYLOR, NOONE & CO; 4434-4438 Penn (W** St.; Frankford; John C. Noone, supt.; Shoddy and Waste; steam; sell direct; Nathaniel G. Taylor, buyer.
- THOMAS, H. B; 3rd, below Ontario St; (W** Map E; Sq. 64; Wool and Merino Yarns; 3 sets; steam; sell direct; H. B. Thomas, buyer.
- THORNTON, URIAH; Madison and Ken- (W** sington Aves; Carpet Yarns; 500 spindles; 2 sets; steam; sell direct.
- THORNTON, WM; Kensington Woolen (W** Mills; 1214 Crease St; Map C; Sq. 54; Theo. Edwards, supt.; Carpet Yarns; 6 sets; 850 spindles; steam; sell direct; Wm. Thornton, buyer.
- THORPE, RICHARD; Irwell Mills; Sta- (C & L** tion E; W. H. Thorpe, supt.; Cotton Damask, Linen Towels; 58 looms; steam; bleach; Albert D. Smith, N. Y., s. agt; W. H. Thorpe, buyer. (Buy 20s cotton and linen yarns.)
- THREAPLETON, WM. B; Howard and (K** Huntingdon Sts; Map C; Sq. 62; Full Fashioned and Seamless Cotton Ribbed Hosiery; 175 knitting machines; steam; Wesendonck, Lorenz & Co, N. Y., s. agts; also sell direct; Wm. B. Threapleton, buyer.
- THURMAN, HARRY W; (formerly Joseph (K** Thurman, Jr.); Rainbow Knitting Mills; 427-437 Ashmead St; Germantown; Map D; Sq. 91; Athletic Knit Goods, Shawls, Etc; 50 knitting machines; steam; sell direct.
- TOGA TEXTILE CO; Emerald and Adams (W** Sts; Map A; Sq. 42; \$25,000; Thos. D. Moulds, treas.; E. White, supt.; Woolen Goods and Shawls; 35 looms; steam; H. J. Libby & Co, N. Y., s. agts; E. White, buyer.
- TITHERINGTON, ELI, & SONS; 79 Wister (W** St; Germantown; Map D; Sq. 91; Upholstery Goods; 6 looms; steam; R. Bierwirth, 41 Union Sq, N. Y., s. agt; W. Titherington, buyer. (Buy cotton yarns.)
- TOPHAM, CHAS. H; Wister St and P. & (W** R. Rk, Germantown; Map D; Sq. 92; Chas. H. Topham, mgr; Garnetting Worsted Waste; 2 garnet machines; steam; sell direct.
- TOPHAM, CHAS; (formerly Henry Top- (C** ham); 2632 Mascher St; India Lace Curtains and Fancy Goods; 5 looms; steam; sell direct; Henry Topham, buyer.
- TOURNIER & LAUBER; Blair St. and (C** Columbia Ave; Map C; Sq. 53; Upholstery Goods; 20 looms.
- TOWNSEND, EDWARD, 2419 Waterloo (K** St; Map C; Sq. 62; Fancy Knit Goods; 5 knitting machines; steam; sell direct; Edw. Townsend, buyer.
- TOWNSEND, E. A. & CO; Main St. (W & D** and Walnut Lane, Manayunk; Map F; Sq. 81; E. A. Townsend, supt; Wool Extracts, Custom Carbonizing and Dyeing; 2 carbonizers; 1 picker; 2 willows; steam and water; dye.
- TRACY WORSTED MILLS CO, THE; 2500 (W** Spruce St; Map B; Sq. 36; \$300,000; D. D. Tracy, pres; J.A. Perkins, treas; R. C. Binder, sec; Worsted Yarns; (English System); 13 combs; 7,720 spindles; steam; sell direct; R. C. Binder, buyer.
- TRAVIS YARN CO; (formerly John W. (C** Travis & Bro.); Madison below Kensington Ave; \$30,000; Cotton Carpet Yarns; 840 spindles; 4 sets; steam; sell direct; J. W. Travis, buyer.
- TROTH, WM. P, JR, & CO; Langdell Mills; (C** 435 Franklin St; Frankford; Map E; Sq. 80; Shirtings, Ginghams, Chevions, etc; 425 looms; steam; Jos. W. Cooke & Co, N. Y. and Phila., s. agts.
- TURNER, DANIEL. (See Bay View, Md.)**
- UNITED STATES KNITTING MILLS; Block (K** & Reinheimer; N. W. cor. 4th and Market Sts.; David Block, mgr.; Max Reinheimer, supt.; Sweaters, Bathing Suits, Athletic Goods and Bicycle Hose; 30 knitting and 35 sewing machines; sell direct; N. Y. office, Room 505, 260 W Broadway; David Block, buyer.
- VALKONE DYE & FINISHING WORKS; (D & F** Sullivan & Webster, props; Turner and Mascher Sts; Map C; Sq. 54; Dyers and Finishers Woolen, Worsted and Mixed Fabrics, Piece Goods Dyeing a Specialty.
- VAUGHAN, E.; Mascher St. and Columbia (K** Ave; Map C; Sq. 54; A. E. Vaughan, supt; Ribbed Hosiery; 129 knitting machines; steam; J. Y. W. Du Bois, 43 Leonard St., N. Y., s. agt; A. E. Vaughn, buyer.
- VERNON, S; Howard and Palmer Sts; (K** Map C; Sq. 54; Cut and Seamless Hosiery, Ribbed and Plain; 150 knitting machines; steam; sell direct; S. Vernon, buyer.
- VICTORIA PLUSH MILL; See Swathmore.**
- VIGILANT MILLS; 1832 Harold St; \$60,000; (S** A. Krauth pres; Johannes Meyer, treas. and agt; Max Sparbert, supt. and buyer; Tapestry and Upholstery Goods; 36 looms; steam; N. Y. salesroom, 73 Leonard St.
- VOELL, ANTHONY; Allegheny and Ken- (S** sington Aves; Map C; Sq. 71; Silks; 9 looms; steam.
- VOGLER, JOHN G; 2623 N. Bodine St; (M** Map C; Sq. 70; (P. O. address, 622 Chestnut St.); Fine Woolen and Worsted Dress Goods; 38 looms; steam; sell direct; John G. Vogler, buyer.
- WARASH MILLS CO; (Inc.); \$50,000; (C & W** Manayunk; Map F, Sq. 73; Arthur N. Leeds, pres; Walter P. Stokes, treas.; Samuel Stead, supt; Carpet and Blanket Yarns, 11 sets; 2,550 mule spindles; steam; sell direct; Arthur N. Leeds, buyer. (Office, 208 Church St.)
- WALKER, ROBT. J; EST. OF; 2230 West (F** Girard Ave; Star Finishing Works; Finishing Cotton and Worsted Goods; Upholstery and Dress Goods; steam.
- WALKER, ISAAC; Frogmore Mill; Frank- (C** ford; Map E; Sq. 80; Cotton Yarns; 7500 mule spindles; steam; dye; sell direct.
- WALL & DAVIES; Unity & Leiper Sts; (C** Frankford; Map E; Sq. 80; Damasks; 10 looms; steam; sell direct and Hamilton & Co, 113 Worth St., N. Y., s. agts; firm, buyers.
- WALLACE, J. H, & BRO; office and ware- (W** house, 1620 Lombard St; mill, Juniper and Snyder Ave; Map B; Sq. 36; Woolen Waste, Garnetted Worsted; 4 pickers; 14 garnet machines; 4 willows; steam; sell direct; firm, buyers.

- WALLISER, AUGUST; 1024 Arch St; Map B; (**S**) Sq. 45; Fringes, Tassels, Cords, Dress Trimmings; 1 loom; hand; sell direct; A. Walliser, buyer.
- WALLISER'S, CHAS. SONS; Marshall and (**S**) Susquehanna Ave; Upholstery, Dress Trimmings, Millinery, Fringes, Etc; 12 chenille machines; 14 looms; hand and steam power; sell direct; Mr. Walliser, buyer.
- WALTER, F. W. & Co; Nicetown Mills; (**W**) Nicetown; James Hilton, supt; Wool Shoddies and Garnetted Worsted Shoddy; 5 cards; 3 pickers; 1 garnett machine; steam; sell direct; F. W. Walter, buyer.
- WALTHER, LOUIS & Co; Third and Le. (**W**) high Ave; Dress Goods; 72 looms; Geo. R. Oettel, with Wm. Schroeder & Co, 469 Broome St, N. Y., s. agt.
- WARD, JAMES; Rear 4979 Sheldon St; (**K**) Germantown; Map D; Sq. 92; Hand Made Bicycle Stockings and Ladies' Skirts; 8 knitting machines; sell direct; J. Ward, buyer.
- WARD, JAMES B. & Bro; Howard St. and (**C**) Lehigh Ave; Map A; Sq. 61; Turkish Towels, Terry Cloth and Novelties; 15 looms; steam; bleach; Albert D. Smith, N. Y., s. agt; James B. Ward, buyer. (Buy 1/4, 1/2, 2/16, 2/20s cotton warps and 162 cotton cops.)
- WARDLOW, J. & W; 1543-45 Rnan St; (**C**) Frankford; Table Damask; 24 looms; steam; Whitman & Phelps, N. Y., s. agts; J. & W. Wardlow, buyers.
- WATERS, D. F; 53 and 55 Wister St; Ger (**D**) mantown; Map D; Sq. 32; Dyer Eider-down, Cotton, Wool and Worsted Yarns and Hosiery, also Cotton Warps; steam.
- WATKINSON, GEO. & Co; 36th and Reed (**K**) Sts; Eel Boots for Rubber Overshoes; 6 sets; steam; sell direct; firm buyers. *Failed.*
- WATT & Bro; Trenton Ave. & Sergeant (**W**) St; Ingrains; 40 looms; steam; sell direct; Wm. Watt, buyer.
- WATT'S, JOHN, SONS; Howard and Mont- (**W**) gomery Aves; Map C; Sq. 54; Ingrain and Granite Carpets, All Grades; 20 looms; steam; sell direct; Joseph Watt, buyer.
- WAVERLEY WORSTED CO; Main St. and (**W**) Green Lane, Manayunk; W. H. Humphreys, agt; Worsted Yarns for Weaving and Knitting; 2000 spindles and 4 twisters; steam.
- WAXLER, JNO. L; Frankford St. and (**D**) Frankford Creek; Frankford; E. S. Waxler, agt. and supt.; Dye Cotton and Wool; steam.
- WAY MFG. CO, THE. *Out of business.*
- WAYNE JUNCTION SPINNING CO.; Wayne (**W**) junction; Frank J. Shelle, pres.; E. C. Jackson, vice-pres.; Wm. F. Kemp, sec. and treas.; Worsted and Woolen Yarns; 3,000 worsted spindles; 5 combs; 7 sets; sell direct.
- WEBER & Co; 1725 No. Howard St; East (**D**) Black Dye Works; Hosiery and Skein Yarns.
- WEBER, CHAS; 2044-18 Orleans St; Fine (**K**) Gauge Seamless Hosiery; 150 knitting machines; steam; Chas. Weber, buyer.
- WEBER, EDWARD; Continental Carpet (**W**) Mill; Mascher and Oxford Sts; Map C; Sq. 54; Cotton and Wool Ingrain Carpets; 12 looms; steam; sell direct.
- WEBER, LOUIS & Co; 404-44 Memphis St; (**K**) Map C; Sq. 54; Fine Seamless Cotton Hosiery; 150 knitting machines; steam; sell direct; Louis Weber, buyer.
- WEDGE, JOHN; 129 Queen St; German- (**K**) town; Map D; Sq. 83; Surgical Hosiery; 11 knitting machines.
- WEIERMAN, CHAS. S.; Mascher and (**K**) Oxford Sts; Map C; Sq. 54; Hosiery; 80 knitting and 12 sewing machines; steam; sell direct, and Chaffee, Moorehouse & Co, N. Y., s. agts; Chas. S. Weierman, buyer.
- WEIMAR Bros; 2046 Amber St; Map (**C** & **S**) C; Sq. 62; W. D. Weimar, treas; Andrew Weimar, supt; Tapes and Narrow Bindings, Plain Cotton and Mercerized; sell direct; Wm. D. Weimar, buyer. (Buy 10/1 40/1 and 12/2, 80/2 warps and skein.)
- WEINMANN, THOS. & SONS; 1732 Howard (**D**) St; Map C; Sq. 54; Dyers Woolen and Worsted Yarns; steam.
- WELCOME MFG. CO; Adams and Amber (**C**) Sts; Map C; Sq. 62; Daniel Wade, pres; Owen Kelley, treas; Tickings; 123 looms; steam; sell direct; firm buyers. (Buy 20s warp and 22s filling.)
- WERNER, FERD; Hancock and Somerset (**W**) Sts; Map C; Sq. 62; Ingrains; 22 looms; steam; sell direct; F. Werner, buyer.
- WEST, SAMUEL; 240 Ashmead St; Ger- (**K**) mantown; Map D; Sq. 91; Plain and Ribbed Hosiery; 200 knitting machines; steam; sell direct; Samuel West, buyer.
- WESTERMAN, S. A.; 2632 Mascher St; (**C** & **S**) Philadelphia; Art Embroideries; steam; sell direct.
- WESTERN & WELLS MFG CO., THE; (**C**) 2100,000; Chas. H. Bond, pres.; Chas. H. Bond, Jr., treas; Woven Cotton Hammocks, School Bags, etc; steam; sell direct; C. H. Bond, Jr., Buyer.
- WESTMORLAND DYE WORKS; Richard- (**D**) son, Weir & Co.; 1919 Westmorland St; Dye Woolen and Worsted Yarns and Tops; steam.
- WHARTENRY, EDWARD F; Unity and (**K**) Leiper Sts; Map E; Sq. 80; Hosiery.
- WHITAKER, J. & Bro; Trenton Ave. and (**W**) Sergeant St; Map A; Sq. 62; Carpet and Rug Yarns; 12 sets; steam; sell direct; J. Whitaker, buyer.
- WHITAKER, WM. D; Emerald and West- (**C**) moreland Sts; Map E; Sq. 79; Cotton Rope and Cotton Yarn; 2000 spindles; steam.
- WHITAKER, WM. & SONS; Olney Road; (**C**) Cedar Grove Mill; Frankford; not shown on map; Tickings, Stripes and Yarns; 17,000 spindles; 315 looms; dye; office, 203 Church St.
- WHITE, A. W; 1410 Oxford St; Map C; (**D**) Sq. 53; Dye Cotton and Woolen Yarns; steam; A. W. White, buyer.
- WHITE, SAMUEL; Centennial Carpet (**W**) Mills; Columbia Ave. and Front St; Map C; Sq. 54; Wool and India Jute Smyrna Rugs and Carpets; 90 looms; steam; sell direct.
- WHY BROS. & Co; Wakefield Knitting (**K**) Co.; 5130 Wakefield St; Germantown; Map D; Sq. 92; John Why, supt; Worsted and Woolen Gloves and Mittens; 150 knitting machines; steam; C. B. Behrens, N. Y., s. agt; John Why, buyer. (Buy yarns.)
- WHY, THOS; 296 E. Bringham St; Ger- (**K**) mantown; Map D; Sq. 91; Knit Gloves; 25 knitting machines; steam; Thompson, Foust & Co, Phila. and O. L. Bailey & Co, Boston, Mass, s. agts; Thos. Why, buyer.
- WILDE, JNO. & Bro; Manayunk; Map F; (**W**) Sq. 73; Carpet Yarns; 4 sets; steam; sell direct; Jno. Wild, buyer.
- WILDE'S, ROBT. SON; Hamilton St. and (**W**) Leverington Ave; Manayunk; Map F; Sq. 72; Carpet Yarns; 9 sets; 1,210 mule spindles; steam; sell direct; firm, buyer.
- WILKINSON, E. & SON; Adams and Am- (**C**) ber Sts; Map C; Sq. 62; Daniel J. Taylor, supt; Dress Goods, Linseys, Checks, Etc; 150 looms; steam; E. H. Hamilton & Co. 113 Worth St. and H. C. Childs & Co. 18 and 20 Thomas St, N. Y., s. agts; E. Wilkinson, Sr, buyer.

- WILLCOX, SAMUEL E.**; 1213 Day St.; Cot. (C) ton Bating; 2 cards; sell direct.
- WILLEY JOHN HENRY**; E. Collum St. (W) & P. R.R.; Germantown; Yarn Spinner.
- WILLIAMS, JOHN, MFG. Co**; 12th and (W) Carpenter Sts; Map A; Sq. 37; Flannels, Cassimeres, Dress Goods, Oxfords, Etc; 5 sets; 233 looms; steam; dye; sell direct; firm, buyers; N. Y. office, 47 Leonard St. (Also Trenton, N. J.)
- WILLIAMSON, JAS. & Co**; Lena St; Ger. (W) mantown; Map D; Sq. 91; Shawls, Lap Robes, Horse Blankets; 20 looms; steam; sell direct; Mr. Jameson, buyer.
- WILSON'S, CHAS. SONS**; Meadow (D & Pr) Spring Dye & Print Works; 1633 Meadow St; Frankford; Map E; Sq. 80; Napping, Dyeing and Printing Cotton Goods; 4 printing machines; steam; Wade Wilson, buyer.
- WILSON, JAMES, & SONS**; 1133 No. 4th (C) St; Carpet Binding and Cotton Tape; 175 looms; steam; sell direct; firm, buyers.
- WILSON, THOS. H**; Hampden Woolen (W) Mills; 1420 Howard St; Map C; Sq. 54; George Kritler, supt; Men's Wear, Dress Goods, Cloakings; 260 broad looms; steam; Jacob Wendall & Co, s. agts; also sell direct; T. H. Wilson, buyer.
- WILSON, WALLACE**; Vigilant Mills; Or. (K) chard below Unity St.; Infants' and Misses' Ribbed, Seamless and Cut Hosiery; 185 knitting machines; 4 sewing machines; steam; sell direct, and John M. Given, Pittsburg, s. agt; W. Wilson, buyer. (Buy 18s to 22s cotton yarn.)
- WILTON HYGIENE UNDERWEAR KNITTING (K) Co**; 11th and Cambria Sts; \$10,000; John Maxwell, pres, and treas; Chas. T. Maxwell, supt; Fleece Underwear, Athletic Goods and Eiderdown Novelities; 20 knitting machines; steam; sell direct; John Maxwell, buyer.
- WILTSHIRE MFG. Co, LTD**; 618 No. (W & C) 21st St; Map A; Sq. 41; Woolen and Cotton Dress Goods; 68 looms; office, 1024 Market St.
- WINFIELD MFG. Co**; Allegheny Ave. (C & W) and A Sts; \$12,000; J. Chambers Greer, pres; Jas. S. McMaster, treas; Cotton and Woolen Dress Goods; 72 looms; steam; finish; sell direct; firm, buyers.
- WINGBOCKING MILLS Co**; Frankford; (C) Map E; Sq. 80; Joshua Garsed, treas; W. R. Garsed, supt; Cotton Yarns, Ropes and Twines, from 2 to 20 ply; 20,000 spindles; steam; sell direct; Joshua Garsed, buyer.
- WINK, B. & Co**; Clifton Mills; Ken. (W) sington Ave. and Huntingdon; Map C; Sq. 62; Paul Bentel, supt; Worsted Coatings, Cloakings and Dress Goods; 60 looms; steam; sell direct and Bacon & Co, s. agts; F. Wink, buyer. (Buy cotton and worst d yarns.)
- WITTY, CHAS. H. & Co**; Hancock and (C) and Huntingdon Sts; Map A; Sq. 61; William Sumner, supt; Damask, Quilts, Table Covers, etc.; 163 looms; steam; dye; sell direct; Chas. H. Witty, buyer. (Buy different skeins and warps.)
- WOLGANUTH'S, F. F. SONS**; Mascher (C & S) and Turner Sts; Map C; Sq. 54; Silks and Silk and Cotton Goods; 32 looms; steam; sell direct.
- WOLSTENCROFT, WILLIAM**; Mulberry, (W) near Bridge St; Frankford; Map E; Sq. 80; James Wolstencroft, supt; Felts; 6 sets; steam; dye; sell direct.
- WOLSTENHOLME & CLARKE**; Baker and (W) Mallory Sts; Manayunk; Worsted and Worsted Merino Yarns, 16s to 60s; (French System); 10,000 spindles; 4 sets; 6 Noble combs; steam; sell direct.
- WOLSTENHOLME, THOS. SONS, & Co**; (W) Allegheny Worsted Mills; Frankford Ave. and Westmoreland St; Map E; Sq. 71; Worsted Yarns; (French and English Systems); 23,400 spindles; 48 combs; steam; dye; sell direct.
- WOOD & LOGAN**; Earham & Lena St; (C) Germantown; Bed Comfortables; steam; firm, buyers.
- WOOD, SAM'L**; 109 Jefferson St; Ger. (W) mantown; Map D; Sq. 91; John A. Wood, supt; Cotton, Wool and Merino Yarns; 3 sets; steam; dye; sell direct; Sam'l Wood, buyer.
- WOOD, WM. & Co**. See *Pequa Mills*.
- WOODCOCK BROS**; 109 Jefferson St; In. (K) dustry Knitting Mills; Germantown; Map D; Sq. 91; Fancy Hammocks, Sweaters, Shirts, etc; 125 knitting machines; 11 looms; steam; Watson, Porter, Giles & Co, (hammocks) and A. D. Schroeder (underwear), N. Y. s. agts; Thos. J. Woodcock, buyer.
- WOODCOCK & KINZEL**, Mill and Cumber. (K) land Sts; Germantown; Map D; Sq. 91; Seamless and Cut Cotton Hosiery; 120 knitting and 12 sewing machines; steam; sell direct; Sam'l Woodcock, buyer.
- WOODHEAD, I. C**; Garden and Locust (C&S) Sts; Bridesburg; Damask and Upholstery Goods; 12 looms; sell direct. (Buy skein cotton, 1/10, 3/16, 2/16, 2/20, 2/60 and warps, 2/30, 2/40, 2/120.)
- WOODHEAD, L. R**; 2718 Hancock St. (C & S) Map A; Sq. 61; Upholstery Goods; 14 looms; steam; sell direct; L. R. Woodhead, buyer. (Buy yarns, 4/1, 3/16, 2/20, 2/40, 2/16.)
- WORLD DYEING & FINISHING WORKS**. *Out of business.*
- WRIGHT, S. D. & Co**; 1017 No. Front St; (C) Map C; Sq. 54; Webbing, Bindings, Etc; 40 looms; steam; sell direct; S. D. Wright, buyer.
- WRIGHT, WM. L**; rear of 4129 German. (W) town Ave; (formerly M. J. Leckie); Map A; Sq. 81; Garnetted Wool Waste and Shoddy; 3 sets; 2 pickers; 1 willow; 1 duster; steam.
- WRIGHTSON, J. & Co.**; 1907 N. Sixth St.; (K) Men's and Women's Cotton Fancy Hosiery; 96 knitting machines; steam; sell direct. (Buy yarn.)
- WRIGHTSON, R. N**; 1909 No. 6th St; Map (K) B; Sq. 57; Plain and Fancy Seamless Hosiery and Eiderdown; steam; sell direct; R. N. Wrightson, buyer. (Buy yarns, 1/14, 1/15, 1/18, 1/20, and 1/24, 1/28 and 1/40 cops, cones or skein.)
- YEWDALE & JONES**; Penn Worsted (W) Mills; 54th and Poplar St; Map A; Sq. 41; Worsted Yarns (English System); 6 cards; 5 combs; 4,500 spindles; steam; sell direct; J. Jones, buyer.
- YOUNG, JOHN B**; 2421 Mascher St; Cotton (C) Banding, Spool Tapes, Lacing Twine, etc.
- YOUNG, WM. M**; 2421 Mascher St.; (C & S) Hook Bands, Cotton Banding, Spool Tape, Bindings; 80 looms; steam; sell direct.
- ZENGERL BROS**; 503 N. Eleventh St; (W) Rug Fringes; 11 looms; sell direct and Carroll L. Hooper, Boston, D. R. Sherratt, N. Y., s. agts.

# PENNSYLVANIA.

See map on page 232.

For explanation of abbreviations see page 66.

- Academy Corners.** B.9. A. & P. RR; F. B. C. Co's RR, Conawesque Br.
- INGHAM, J. S.;** Flannels and Yarn; 1 (W set); 3 looms; steam and water; dye; sell direct.
- Adamstown.** H.13. R. & S. W. RR; Electric from Reading.
- BOLLMAN, GEO. & Co;** Wool Hats; 4 (W sets); steam; dye.
- FRIETHORN, REDCAY & Co;** Industry (W Mill; Wool Hats; 4 sets; steam; dye; C. H. Tenney & Co, N. Y., s. agts.
- MOHN, PIERCE;** Adamstown Hosiery (K Mill; 108 needle goods; 24 knitting machines; 6 looping machines; steam; C. H. Swearingen, s. agt. (Buy 8s to 12s yarns.)
- Albion.** B.1. P. RR; (Eric & Pittsburg); P. S. & L. E. RR.
- THORNTON, WM;** Albion Woolen Mills; (W Kerseys, Flannels, Blankets and Yarns; 1 set; 9 looms; 2 knitting machines; steam; dye; Wm. Thornton, s. agt. *Not running.*
- Alburtis.** G.14. Phila. & Reading RR.
- HARTLEY SILK MFG. Co;** Herbert Hart. (D Lety, pres; John Hartley, treas. and supt; Broad Dress Silks and Tie Silks; 50 looms; steam; Passavant & Co., s. agts. (Also Topton)
- Allegheny.** G.2. P. RR, West Penn. Div; P. F. W. & C. RR, Eastern Div; P. & W. RR, Western Div.
- FLOCKER, JOHN & Co;** Twine; (J Cordage and Hemp Packing; 20 machines; steam; office, 618 Liberty Ave., Pittsburg.
- WESTERN PENITENTIARY OF PA;** Edw. (K S. Wright, Warden; J. M. Ray, mgr. mfg. industries and buyer; Men's Half Hose; 60 knitting machines; sell direct. (Buy 8s and 11s white cones, 9 1/2s, 11s and 15s mixtures on cones.)
- Alleghenville.** G.8. P. RR, Middle Div.
- WEBB, T. A. W., & SON;** Blankets, Flannels, Satinets, Hosiery Yarns; 1 set; 5 looms; water; dye; sell direct.
- Allentown.** (Lehigh County.) G.15. C. RR. of N. J., Lehigh & Susquehanna Div; L. V. RR, Lehigh Div; Perkiomen RR; P. & R. RR, East Penn. Br.
- ACME BLEACHING CO;** 14 So. Church (B & D St; (Samuel E. Peters and Amos O. Krasley); Bleaching and Dyeing for Knit Goods Trade; steam.
- ALLENTOWN KNITTING CO;** 38 and 40 So. (K Church St.; A. K. Jacks, treas and buyer; Ladies' Ribbed Vests; 21 knitting machines; 14 sewing machines; steam; finish; Porter Bros. & Co., N. Y., s. agts. (Buy 20s and 22s yarn.)
- ALLENTOWN SILK CO.** (formerly Pioneer (S Silk Mill); C. Piva, pres.; E. Gerli, treas.; G. P. Frova, supt.; Tram, Organzine, Ribbons; 25,000 spindles; 100 looms; steam.
- ALLENTOWN SPINNING CO.;** J. E. Bar. (J bour, pres.; Wm. Thompson, treas.; D. R. Makeohl, supt.; Jute Carpet and Rug Yarn and Twine; 4670 spindles; steam; dye; The Linen Thread Co., N. Y., s. agts.
- AUGER & SIMON SILK DYING CO.** See (D Paterson, N. J.
- CLINTON KNITTING CO.;** Hall and Court (K Sts; C. D. Strauss, pres and treas.; J. F. Thompson, supt.; Ladies' Cotton Ribbed Underwear; 15 knitting machines; steam; Critten, Clift & Co., s. agts. (Buy 22s yarn.
- GABRIEL'S, H. SOSS;** Allentown (K, D & B) Hosiery Co; Hosiery, Misses' Ribbed and Ladies' and Men's Fine Mercerized Goods; 200 knitting machines; 40 ribbers; 10 looms; 8 sewing machines; water and steam; dye; bleach for the trade; sell direct. (Buy 8, 10, 12, 16, 20s carded and 20 1/2, 24 1/2, 26 1/2 combed Peeler and Egyptian.)
- GIVERNAUD BROS;** Broad Silks; 43 (S looms; steam; N. Y. office, 31 Greene St; also West Hoboken, N. J., Homestead and Hackensack.
- LECHA SILK CO.;** West End Mill; \$50,000; (S Charles Riber, pres. and supt.; John A. McColom, treas.; Silk Ribbons; 27 looms; steam; Wm. P. Gill & Co., N. Y., s. agts.; John A. McColom, buyer. (Buy 40 1/2 ply bleached cotton yarn.)
- LEHIGH KNITTING MILLS;** C. Swartz, (K prop; Hall and Court Sts; Wm. H. Werley, supt; Ladies' Cotton Ribbed Underwear; 16 knitting machines; steam; sell through agents; W. C. Swartz, buyer.
- LOTTE & MAZERES CO., THE;** Edw. F. L. (D Lotte, pres; Chas. E. Lotte, sec; Skein Silk Dyers in Blacks and Colors; steam; sell direct. (Formerly in Phila.)
- MACK SILK CO, JOSEPH S, THE;** \$50,000; (S L. E. Schimpff, pres.; Joseph S. Mack, treas.; Commission Silk Throwsters; 1,300 spindles; steam; Jos. S. Mack, buyer. (Also Scranton, Pa.)
- PALACE RIBBON MFG. CO;** \$30,000; Max (S Wolff, pres. and treas; John Gradlin, supt; Ribbons; 10,000 spindles; 125 looms; steam; Chas. Wolff & Co., N. Y., s. agts. (Buy 40 1/2 Peeler 100 2 glazed)
- PHOENIX SILK MFG. CO.** (Adelaide (S Mills); Edward A. Soleliac, mgr. and buyer; 1300 broad silk looms; 200 ribbon looms; steam; Greiff & Co., 106-112 Spring St., N. Y., s. agts. See main office, Paterson, N. J.) Also Pottsville, Pa.
- RIBSON SILK MILLS;** Chas. A. Zinder. (S stein; Throwing and Weaving Ribbons; 40 looms; 5,000 spindles; steam; sell direct.
- ROSS, RICHARD;** Summer Ave; Skein (D Silk Dyer.
- SOUTHDOWN KNITTING CO;** 14 So. Church (K St; \$60,000; W. H. Weinsheimer, pres; Frank Jacobs, treas; Cotton, Lisle and Silk Ladies' Ribbed Underwear; 50 knitting machines; 75 sewing machines; steam and electric power; Bateson and Dowd, N. Y., s. agts. Buy combed and carded Peeler and Egyptian from 8 to 22, combed Peeler bleached 22 1/2, Lisle, mercerized 46 1/2 and others.)
- WAUBERT, WM;** Eagle Mill; Hosiery; 30 (K knitting machines; steam; sell direct.
- WEILBACHER, FRANK;** Fancy Ribbons; 72 (S looms; steam. (E. & H. Levy, bosses.)
- Altoona.** G.6. Penn. RR; P. J. E. & E. RR.
- JUNIAT THROWING CO.;** Throwing. See (S *Mayhew Silk Co.*
- MAYHEW SILK CO.;** Broad Silks; 100 (S looms. (Also see Juniata Throwing Co. and Paterson, N. J.)
- SCHWARZENBACH, HUBER & Co;** (also (S Hollidaysburg, Pa., and West Hoboken,





- N. J.); Broad Silks and Throwing; 42,000 spindles; 600 looms; electricity.
- Annville.** H-12. Phila. & Read RR.
- KREIDER, A. R. & BRO; Fine Gauge, (K) Seamless Cotton Half Hose and Misses' Heavy Ribbed Hose; 39 knitting machines; 5 loopers; steam; sell direct; N. Y. office, 75 Franklin St.; A. R. Kreider, buyer. (Buy white yarn, 11s, 14s, 18s, 40s.)
- Antes Fort.** E-10. P (Sudbury & Driftwood Line); Beech Creek & F. B. C. Co; Pine Creek Div. RR's.
- LEINBACH WOOLEN CO; Nippenose (W) Woolen Mills; \$36,000; W. S. Leinbach, pres, and supt; J. S. Leinbach, treas; Woolen Cassimeres; 3 sets; 14 looms; water and steam; dye; sell direct. (Buy 20/2 warp.) *Reported closed indefinitely.*
- Apollo.** G-3. Penn. RR.
- APOLLO WOOLEN MILLS, LTD; \$8,000; (W) W. S. Beamer, pres; E. A. Townsend, treas; W. W. Flinn, supt; Blankets, Flannels and Yarn; 1 set; 9 looms; steam; E. A. Townsend, s. agt.
- Ardmore.** J-15. P. RR, Phila. Div.
- BURNS, JOHN; Nitre Hall Mill; Single (C) and Double Cotton Carpet Yarn; 2 sets; 84 spindles; water; sell direct.
- CLEGG, THOS. & CO.; Meadow Grove Mills. *Burned.*
- Ashley.** E-13. C. R. R. of N. J.
- ASHLEY KNITTING MILLS; Ambrose (K) West, prop; Cotton Fancy Hose; 150 knitting machines; steam; sell direct; Ambrose West, buyer. (*Also Plymouth.*)
- Aston Mills.** K-15. P. W. & B, Central Div, Chester Creek Line.
- RHODES BROS. (LTD); Aston & West (W) Branch Mills; \$400,000; John B. Rhodes, pres, and treas; R. Somers Rhodes, supt; Doeskins, Jeans, Cotton Worsted, Kerseys and Fancy Woolens, Domets, Etc; 32 sets; 600 looms; steam and water; dye; Wm. Iselin & Co, N. Y., s. agts.
- Athens.** B-11. L. V. RR.
- THIGA SILK CO; \$40,000; Edwin J. Becker, (S) pres; Alphonse A. Cardinal, vice pres; Frederick W. Becker, sec, and treas; Thos. Holt, supt; Broad Silks; 100 looms; Schefer, Schramm & Vogel, N. Y., s. agts. (No report, 1902.)
- Attleboro.** Bucks County.
- RUMPF'S, FREDERICK, SONS; Turkey Red (C) Damask, Lap Robes, etc; 160 looms; steam; dye; sell direct. (P. O. address Eden.)
- Auburn.** G-13. P. Schuylkill Div, P. & R, Schuylkill & Susquehanna Beh.
- AUBURN KNITTING MILLS; W. H. Diefen (K) derter & Co; Ladies' and Misses' Cotton Underwear; 20 knitting machines; 25 sewing machines; steam; Lindsay J. Riggins, White St., N. Y., s. agt. W. H. Diefenderter, buyer. (Buy yarns, 9 to 24.)
- Avoca.** D-14. D. & H. RR; C. R. of N. J.; L. V. RR; E. & Y. V. RR.
- AVOCA SILK CO; John Shaw, pres; Wm. (S) H. Ashley, sec, and treas; F. V. Curl, supt; Silk Throwsters; 11,000 spindles; steam. Also see Ashley & Shaw, Hackettstown, N. J.
- Avon.** H-12. P. & R. RR, Lebanon Valley Br.
- LEBANON TEXTILE CO. (formerly Avon (K) Knitting Co.); \$30,000. Saml. L. Light, pres; Stephen A. Light, treas; T. G. Spaulster, sec, and buyer; Ladies' Cotton Ribbed Underwear; 22 knitting machines; steam; Bateson & Dowd, s. agts. (Buy 10s to 24s yarns on cones.)
- LIGHT & BOMBERGER; \$5,000; Men's 144 (K) needle Hose; 18 knitting machines; Sellers & Steele, Pittsburg, Pa, and N. Y., s. agts.
- Bath.** G-15. L. & L. RR.
- BATH SILK MFG. CO; \$12,000; C. J. Davis, (S) pres.; J. H. Shinn, sec, and treas.; W. G. Gordon, supt; Tie and Dress Silks; 50 looms; steam.
- ODENWELDER & CO; Bath Knitting (K) Mills; W. L. Odenwelder, pres; O. W. Lerch, treas.; D. J. Odenwelder, agt; Henry Able, supt; Ex. Fine Cotton Hosiery; 100 knitting machines; steam; dye; sell direct, offices in N. Y., Boston, Chicago and Cincinnati; D. J. Odenwelder, buyer. (Buy 8 to 40/1 yarn.)
- Bell's Landing.** F-6. Beech Creek RR.
- PONTEFRAT, JAMES, & CO; *Burned.* (Removed to New Bethlehem, Pa., which see.)
- Berwick.** E-12. D. L. & W. RR.
- HARTMAN, F. Q.; Thrown Silks and Spe. (S) cialties; 15,274 spindles; steam. (Also see Danville, Pa.)
- Bethlehem.** G-15. C. RR, of N. J., Lehigh and Susquehanna Div; L. & L. RR; P. & R. RR, Bethlehem Br.
- BETHELEHEM SILK CO, THE; \$200,000; W. E. (S) Martin, pres; N. J. Martin, treas; Thos. J. Dyanan, supt; Thrown Silks; 45,000 spindles; steam.
- FICHTER & MARTIN; Ribbons and Broad (S) Silks; 137 ribbon and 40 broad looms; steam; J. Kriebel, Sons & Co, N. Y., s. agts; W. E. Martin, buyer.
- HALCYON KNITTING MILLS (see So. Beth- (K) lehem).
- HANOVER MFG. CO; LTD; Robt. J. Ott, (K) treas; Milton S. Weaver, sec; J. T. Shimer, mgr; Cotton Hosiery and Boys' Heavy Fleece and Double Kneed Stockings; 60 knitting machines; electricity; sell direct; J. T. Shimer, buyer.
- HOHRATH & FICKERT; 10 ribbon looms; (S) Scheffer, Schram & Vogel, N. Y., s. agts.
- SATQUOIT SILK MFG. CO; H. C. Bailey, (S) supt; Yarns and Broad Goods; 9642 spindles; 310 looms; steam; Passavant & Co, s. agts. (Also at Phila, and Scranton, Pa.)
- UNION ST. SILK CO.; 8 Union St. (S)
- Birdsboro.** H-14. P. RR, Schuylkill Div; P. & R. RR; W. & H. RR.
- CAVANAGH, WM. M.; Half Hose, 84 and (K) 98 needle goods; 50 knitting machines; steam; sell direct and D. L. Crowell, 89 Worth St., N. Y., s. agt.; Wm. M. Cavanagh, buyer. (Buy 6, 8 and 24 white and 6, 8, 9, 10, 14 1/2 mixtures.)
- SMITH & ROSS; Wm. Ross, supt.; Men's (K) Half Hose; 176 needle goods; 10 knitting machines; steam; sell direct; either Mr. Smith or Ross, buy.
- Bixler.** H-9. (RR. name Ft. Robinson.) N. & S. V. RR.
- BECK, GEO. E.; Centre Woolen Mills; J. (W) S. Peck, agt.; G. A. Palm, supt.; Blankets, Cassimeres, Flannels; 1 set; 6 looms; water; dye; sell direct.
- Blain.** H-9. N. & S. V. RR.
- COUGH & MORELAND; Perry Knitting (K) Mill; Men's Half Hose; 40 knitting machines; steam; sell direct.
- Bloomsburg.** F-12. B. & S. RR; D. L. & W. RR, Bloomsburg Div; P. & R. RR, Bloomsburg Br.
- BLOOMSBURG SILK MILL; \$200,000; (K) & (S) L. N. Moyer, pres; Joseph Ratti, treas; Throwing and Silk Goods, Hosiery; 10,000 spindles; 300 looms; steam; Fleitmann & Co, N. Y., s. agts.
- CASWELL, E. C. & CO; E. C. Caswell, (W) supt; All Wool Cassimeres; 3 sets; 14 looms; steam; dye; Brannan & Valentine, 86 & 88 Franklin St., N. Y., s. agts.
- MAGEE CARPET WORKS, LTD; THE; (W) \$125,000; W. Law, chairman; James Magee, 2nd, treas. buyer and supt; Tapes

- try and Velvet Carpet, Ingrains and Art Squares and Worsted Yarns; 3000 spindles; 2 sets; 160 looms; steam; dye.
- Boyetown.** H-14. Phila. & Reading RR. (Colebrookdale Branch).
- FRANCIS, DR. K. L. & SON;** Ladies' Cot. (**K**) Ribbed Underwear; Critten, Clift & Co., N. Y., s. agts.
- MOYER, N. H.;** Franklin Knitting Mill. See Orswigsburgh.
- UNGER, G. W.;** Crescent Knitting Mill; (**K**) Ladies' Cotton Ribbed Underwear; 35 knitting machines; steam; sell direct; G. W. Unger, buyer.
- Bradford.** B-6. B. R. & P. RR.; Erie RR.
- LEON, HENRY;** Throwing Silks on Com. (**S**) mission; 7,000 spindles; gas. (Also Paterson, N. J.)
- Bridgeport.** (Montgomery County.) J-15. P & R. RR.
- BARBER, E. L.;** Carpet and Rug Yarns; (**W**) 4 sets; 1100 spindles; steam; sell direct; Wm. Barber, buyer.
- LEES JAMES, & SONS CO.;** \$800,000; Wm. (**W**) Ivins, pres.; Abram T. Eastwick, treas.; W. L. Stauffer, vice-pres. and agt.; C. F. Williams, sec.; T. H. Harley, supt.; Woolen and Worsted Yarns (Bradford system); 100 spinning frames; 16 mules; 54 sets; 20 combs; steam; dye; sell direct; agent and treas., buyers.
- SMITH, ISAAC W.;** Men's Wear, Wooleus (**W**) in 3/4 and 5/4 goods; 4 sets; 20 broad and 70 narrow looms; steam; dye; sell direct and Bacon & Co., N. Y., s. agts.
- STERLING MILLS CO.;** \$100,000; Cassi. (**W**) meres; 2500 spindles; 5 sets; 88 looms; steam; dye.
- Bristol.** J-16. P. RR, N. Y. Div.
- BRISTOL HOSIERY MILLS;** M. C. Hughes, (**K**) prop; Thomas Hughes, mgr; Cotton, Woolen, Silk and Merino Seamless and Cut Hosiery, Underwear; 300 knitting machines; 50 sewing machines; steam; dye; sell direct. (Buy cotton yarns 10 to 22.)
- GRUNDY, W. H. & Co.;** Bristol Worsted (**W**) Mills; Worsted Yarns; (Bradford system); 8000 spindles; 12 combs; steam; Phila. office, 108 So. Front St.
- LEEDOM, THOS. L. & Co.;** Bristol Carpet (**W**) Mills; Carpets; 8 sets; 250 looms; steam; dye; sell direct; 98 Broadway, N. Y.
- BRISTOL KNITTING CO.;** John P. Bruhn, (**K**) pres; D. L. Robertson, treas.; Henry Bruhn, supt; Cotton Hosiery and Underwear; 100 knitting machines; 35 sewing machines; steam; dye; Bruhn, Gerrish & Robertson, s. agts.
- STEEL, EDWARD T. & Co.;** Keystone (**W**) Woolen Mills and Thornbury Worsted Mills; Worsteds and Wooleus; 3 sets woolen; 14 sets worsted; 11 combs; 10,000 worsted spindles (Bradford system); 225 broad looms; steam; dye; salesrooms, 53 Leonard St., N. Y., 24 Bank St, Phila.
- WAY KNITTING MILLS CO.;** \$60,000; A. (**K**) J. Waterman, pres.; Leo J. Fishel, treas.; Men's Underwear and Korsos; 12 knitting machines; 20 sewing machines; steam; dye; Critten, Clift & Co., s. agts.
- WILLIAMS, HOWARD J.;** *Burned.*
- Brodbeck's.** K-11. (Ry. name, Green Ridge.) W. M. RR.
- WERTZ, A. B.;** Codorus Woolen Mills; (**W**) Cassimeres, Blankets, Flannels and Yarns; 1 set; 3 looms; water; dye; sell direct.
- Brookville.** E-5. A. V. RR, Low Grade Div.
- BROOKVILLE WOOLEN MILLS;** William (**W**) Fell, supt.; Cassimeres; 2 sets; 20 looms; steam; dye; Chas. H. Hamilton & Co., s. agts.; Wm. Fell, buyer. (Buy worsted and mercerized yarns.)
- FAWCETT BROS.;** Red Bank Mills; Blank (**W**) ets, Flannels and Yarn; 1 set. 7 looms; steam; dye; sell direct; C. T. Fawcett, buyer.
- Bryan Mill.** E-11. 2 miles No. of Hughesville, on W. & N. B. RR.
- OSLER & ELDER;** Eagle Woolen Mills; (**W**) Flannels and Yarn; 1 set; 5 looms; steam and water; dye; sell direct. Freight address, Hughesville.
- Burnt Cabins.** J-7. East Broad Top RR, Shade Gap Br.
- HERTZLER, H. H.;** Blankets, Yarns, Car. (**W**) pets, Etc.; 2 sets; 2 looms; water; dye; sell direct.
- Butler.** F-3. Pa. RR.
- BUTLER SILK MILL CO.;** W. C. Thompson, (**S**) pres; W. H. Miller, sec; A. M. Reiber, treas.; E. L. England, supt; Broad Silks; 25 looms; gas; sell direct.
- Canton.** C-11. N. C. RR.
- ROCKWELL, JNO. E.;** Canton Wool Mills; (**W**) Custom Carding; 1 card; 1 picker; water.
- Carbondale.** D-14. D. & H. RR; Gravity RR, Penn. Div; N. Y., L. E. & W. RR, Jefferson Br; N. Y., O. & W. RR, Scranton Div.
- EMPIRE SILK CO.;** (branch Paterson (**S**) Mill); Broad Silks; 150 looms.
- KLOTS THROWING CO.;** H. D. Klots, (**S**) pres; Geo. Klots, treas; Thrown Silk, Tram, Orgazine; 17,500 spindles; steam. (Also Scranton, Pa., Cumberland, Md., and Fredericksburg, Va.)
- Cardington.** J-15. P. & D. RR.
- CARDINGTON HOSIERY MILL;** Hosiery; (**K**) 10 knitting machines; steam; sell direct; J. L. Wolfenden, buyer.
- WOLFENDEN, SHORE & Co. (LTD.);** (**C** & **W**) Cardington Mills; \$150,000; Jonathan Wolfenden, chairman; John T. Wolfenden, treas; John Wolfenden, sec; Cotton and Woolen Goods, Cotton Yarns, etc; 5000 spindles; 12 sets; 234 looms; steam and water; dye; F. Victor & Achelis, Doubl, Miller & Co., N. Y., s. agts.
- Carlisle.** H-10. C. V. P. & R. RR, Gettysburg & Harrisburg Line.
- CARLISLE SILK MILL.** See *York Silk Mfg.* (**S**) Co., York, Pa.
- LETORT CARPET CO.;** J. R. Loy, supt.; (**W** & **J**) Rag, Jute, Cottage Ingrain and Letort Agate Carpets; 26 looms; steam; dye; sell direct; J. R. Loy, buyer. (Buy all kinds of yarns.)
- STEPHENS & BEETEM.;** Carlisle Car- (**W**) pet Factory; W. E. Johnson, supt; Venetians, Rag and Jute Filled Carpets; 35 looms; electric power; dye; J. C. Stevens and E. C. Bectem, s. agts; J. C. Stevens, buyer.
- Catsaunqua.** G-14. L. V. RR, Lehigh Div; C. of N. J. Lehigh & Susquehanna Div; P. & B. RR, Catsaunqua & Fogelsville Br.
- DEK, D. G.;** Broad Silks; 400 looms; (**S**) steam; sell direct, 14 Greene St., N. Y. (Also East Manah Chunk.)
- UNICORN SILK MFG. CO.;** \$200,000; Jno. (**S**) F. Degener, pres; Wm. Degener, treas.; Cotton and Silk Plushes; steam; dye; C. A. Auffmordt & Co., N. Y., s. agts. *Reported not running, May, '02.*
- WAHNETAI SILK CO.;** \$177,500; James (**S**) Thomas, pres; F. M. Horn, treas; Wm. K. Thomas, Jr., supt; Plushes and Corduroys; 41 looms; steam; dye; James Stern & Co., N. Y., s. agts.
- Centerport.** G-B. Near Mohrsville. P. RR, Schuylkill D; P. & R. RR.
- CENTERPORT KNITTING MILL;** J. E. (**K**) Pautsch, prop; Ladies' Ribbed Underwear; 15 knitting machines; 16 sewing machines; gas; L. J. Riggins, N. Y., s. agt. Buy yarns 9s to 24s, Peeler, Egyptian and Silver Grey.)

- Chambersburg.** J-9. C. V. Mont. Alto; W. M. RR. & Cumberland Valley RR.
- CHAMBERSBURG HOSIERY CO.;** \$40,000; (K) T. M. Nelson, pres; A. L. Shafer, treas. and supt; Men's Half Hose, Cotton Fancies and Ladies' Full Fashioned Hosiery; steam; sell direct; A. L. Shafer, buyer.
- CHAMBERSBURG WOOLEN CO.;** (Partner: (W) ship); H. M. White, pres.; E. N. Hutton, treas.; J. S. Murr, supt.; Worsteds, Cloakings and Dress Goods; 5 sets; 33 looms; steam and water; dye; sell direct; D. K. Appenzeller and J. S. Murr, buyers. (Buy worsted yarns.)
- Charlevoix.** J-2. Penn. RR.
- BAMFORD BROS.;** SILK MFG. CO.; *Shut down;* Machinery out.
- Cheltenham.** J-16. P. & R. RR. Phila. and Newton Branch.
- INGRAM, WM. A.;** Removed to W. Philadelphia.
- PIKE, E. V.;** Sunnyside Mills; Jno. R. (S) Pike, supt. and buyer; Chenille Goods and Oriental Curtains; 22 looms; steam; sell direct. (Buy 1/26, 1/20, 8/3, 9/4 all general soft spun upholstery yarn.)
- Chester.** J-15. P. W. & B. Maryland Div; P. & R. Phila. & Chester Br; B. & O. Phila. Div.
- ABERFOYLE MFG. CO.;** \$300,000; W. T. (C & W) Gale, pres. and mgr; C. E. Lord, treas. and sec; Robt. Wetherill, vice-pres; Fine Textile Fabrics; 530 looms; steam; dye; N. Y. office, 329-331 Broadway.
- ARMITAGE, DAVID & SON, Auvergne (W) Mills;** Astrachan Cloth and Ladies' Cloakings; 25 broad and 20 astrachan looms; steam; dye and finish.
- BIRKIN, T. I. & Co.;** 2d, Clayton and (C) Trainer Sts.; J. W. Smith, agt; F. A. Slight, supt.; Lace Curtains, Nettings, Bedsets and Edgings; 4 looms; steam; bleach; sell direct and J. A. Brittain & Co., N. Y., Boston, Chicago and San Francisco, s. agts; J. W. Smith, buyer. (Buy 2/26 to 2/70s.)
- BOWERS, JAS. SONS, LTD.;** \$60,000; C. H. (W) Bowers, supt. and treas; Shoddy and Wool Waste; 12 cards; 4 pickers; 6 garnett machines; steam; dye; Phila. office, 246 Chestnut St.
- BYRAM MFG. Co.;** D. Newsome; Flan. (W) netlets and Cotton Worsteds; 3 sets; 86 looms; steam; dye; Joshua L. Bailly & Co., N. Y. and Phila., s. agts; D. Newsome, buyer.
- CHESTER DYEING CO., LTD.;** Edgemont (D) Ave; James S. Austin, pres; N. P. Sloan (241 Chestnut St, Phila), treas; Richard Stockton, supt; Dyeing Raw Stock and Yarns; Damaged Cotton Reconditioned; steam.
- CHESTER HOSIERY Co.;** *Out of business.*
- CHESTER MFG. Co.;** \$200,000; Chas. M. (C) McLeod, pres.; T. Frank Bartholomew, sec; Table Damask, Turkish Towels, Tickings and Cotton Yarns; 42,000 spindles; 150 looms; steam; dye, finishing and bleaching; W. H. Burgess & Co., N. Y., and W. M. and F. W. Sharples, Phila., s. agts.
- CROZER, S. A. & SON.;** (*See Upland.*) (C)
- DELAWARE MFG. Co.;** (formerly The (W) Hitcher Mfg. Co.); 7th & Morton Sts; So. Chester; S. Hinchen, pres. and treas; Fine Dress Goods and Lastings; 60 looms; steam; sell direct.
- EMMOTT CHESTER WORSTED SPINNING (W) Co.;** \$75,000; James Emmott, pres. and supt.; C. Y. James, treas.; Fine and Medium Worsteds Yarns; 3 worsted cards; 2000 worsted spindles; 3 combs (Bradford system); sell direct; James Emmott, buyer. (In Law & Devaney Mills.)
- ESREY MFG. Co. LTD.;** Powhatan Mills; (W) \$270,000; C. S. Esrey, pres; C. W. Andrew, vice pres. and manager; W. H. Esrey, treas; Jeans, Cassimeres and Doeskins; 26 sets; 350 looms; steam; dye; J. L. Bailly & Co., Phila. and N. Y. and Jas. Talcott, N. Y., s. agts.
- GALEY & LORD MFG. Co.;** (inc. 1895); \$305,000; Wm. T. Galey, pres. and treas; Chas. E. Lord, vice-pres. and sec; Fine Cotton Goods; 565 looms; steam; Galey & Lord, s. agts, 329 Broadway, N. Y. Buy yarn.
- HETZEL, GEO. C. Co.;** Geo. C. Hetzel, (W) pres; G. W. Atherholt, treas; Job Smith, supt; Woolens and Worsteds; 108 looms; steam; dye; Faulkner, Page & Co., N. Y. and Boston, s. agts; Geo. C. Hetzel, buyer.
- HOUSTON MFG. Co.;** \$10,000; H. K. Hous. (C) ton, pres; C. M. McCloud, treas; A. L. Allee, supt; Quilts of all kinds; 6 garnetts; sell direct; H. K. Houston, buyer.
- IRVING, JAMES, & SON.;** Irvington Woolen (W) Mills; Jeans, Tweeds and Cassimeres; 5 sets; 75 looms; water and steam; dye; F. Victor & Achelis and Fleitmann & Co., N. Y., s. agts.
- IRVING & LEIPER MFG. Co.;** \$100,000; Wm. (C) A. Irving, pres; D. Edwin Irving, treas. and mgr; Warps and Hosiery, 68 to 22s, and Underwear Yarns; 14,000 spindles; steam; sell direct; D. Edwin Irving, buyer. (Phila. office, 104 Chestnut St.)
- JORDAN MFG. Co.;** Arasapha Mills; Wm. (C) S. Blakeley, pres.; R. Wetherill, vice-pres.; Irving W. Jordan, sec. and treas.; Robt. F. Kineavy, supt.; Fine Cotton Fabrics; 600 looms; steam; dye and bleach.
- LEWIS, J. WM. & Co.;** Chester Dock Mills; (C) John Pritchard, supt; Stripes, Gingham, Checks, Plaids and Domets; 8050 spindles; 370 looms; steam; dye; P. S. Hutchinsou & Co., Phila., s. agts.
- LINCOLN MFG. Co.;** \$125,000; S. Emlen (C) Meigs, pres; W. H. Weidner, treas. and buyer; American and Egyptian Cotton Yarns; 14,000 spindles; steam; sell direct; office, 400 Bank Bldg, Phila.
- RICHARDSON & ROSS MFG. Co.;** (form. (W & C) erly South Chester Mfg. Co.); B. F. Richardson, pres.; D. H. Ross, treas.; W. K. Roberts, general mgr. and buyer; A. C. Roberts, supt.; Cotton and Woolen Goods for Men's Wear; 2 sets; 100 looms; steam; dye; James Talcott, N. Y., s. agt.
- STANDARD SPINNING Co.;** \$100,000; W. S. (C) Blakeley, pres; E. E. Trainer, treas; T. W. Trainer, sec, supt. and buyer; Fine Hosiery Yarn; 5000 spindles; steam; sell direct.
- STRAUS, F. A. & Co.;** 93 Greene St., N. (W) Y.; Silk and Worsteds Yarns; 5 sets; 5 combs (Bradford system); 2500 worsted spindles. (See also Trenton, N. J. for worsted and Paterson, N. J., for silk mill.)
- Churchtown.** J-13. (Not shown on map.) RR. station Beartown, Pa., RR.
- ALLEN KNITTING CO.;** M. A. Goodhart, (K) pres.; Half Hose. *Proposed.*
- Clifton Heights.** (RR. name, Clifton.) J-15. P. W. & B. RR. Central Div.
- CALEDONIA MILLS Co.;** Caledonia Mills; (W) (formerly John Williams Mfg. Co.); \$50,000; Wm. M. Longstreth, pres; H. Y. Arnold, sec. and treas; James T. Stewart, mgr; Cheviots, Cassimeres, Flannels, etc; 5 sets; 102 looms; steam; dye; sell direct.
- COLUMBUS KNITTING MILLS.;** Samuel J. (K) Quinn, supt; Lace and Fine Ribbed Hosiery; 135 knitting machines; steam; dye; sell direct; Chas. Crawford, buyer. (Buy combed Egyptian yarn.)
- COVERDILL, E. R.;** (P. O. address, Adding (W) ham); Shoddy; 2 pickers; 4 cards; 1 duster.
- GARNETT BROS.;** John Garnett, supt; (C & W) Cotton and Shoddy; 3 pickers; 1 duster; steam; sell direct; Robert L. Garnett, buyer.

- HEY, E. & Co. (P. O. address, Adding (W) ham Pa.); Hosiery Knitting Yarns, Etc; 7 sets; 3,500 spindles; dye; sell direct; Phila. office, 30 No. Front St.
- KENT, THOS. MFG. CO.; \$300,000; Henry (W) T. Kent, pres. and treas; Flannels; 23 sets; 212 looms; steam and water; dye; Faulkner, Page & Co, Boston and N. Y., s. agts. (Also at Buena Vista, Va.)
- KERSHAW, NELSON, LTD; Turkish Tow. (C) els; 180 looms; steam and water; dye bleach house; sell direct and M. J. Warner, s. agt.; Nelson Kershaw, buyer.
- RIDLEY MILL; Thos. Kent Mfg. Co, les. (W) sees; Woolen Yarns; 5 sets.
- RUNNYMEDE WORSTED MILLS; Thos. (W) Kent Mfg. Co; John C. Baldwin, supt; Worsted Yarns; 10,000 spindles; 2½ sets French drawing.
- Coatsville.** J-14. P. RR, Phila Div; W. & N. RR.
- ASHLEY & BAILEY CO; Silks; steam; (S) dye. (Also at Columbia and Marietta, Pa, and Paterson, N. J.)
- GREENWOOD, SAMUEL, WOOLEN MILLS; (W) Samuel M. Greenwood, supt; Shawls, Cassimeres and Flannels; 2 sets; 12 looms; steam and water; dye; F. R. Masters & Co. N. Y., s. agts; James Greenwood, buyer.
- Collegeville.** H-15. (Not shown on map.) S. V. P. RR.
- TODD, BURGESS WILLIAM; Hosiery. *Pro.* (K) posed.
- Collingdale.** J-15. 1½ m. s. w. of Darby.
- COLLINGDALE HOSEIERY MILL; Ladies' (K) and Men's Cotton and Woolen Seamless Hosiery; 20 knitting machines; sells through agts. (Buy 16 and 17 yarn.)
- Columbia.** J-12. P. & R. RR; P. RR, Columbia Br, Columbia & Port Deposit Br.
- ASHLEY & BAILEY; \$800,000; (also Paterson, N. J., Fayetteville, N. C., Marietta and Coatsville, Pa.) D. Ashley, pres; P. Bailey, treas; Throwing, Dress and Tie Silks, Ribbons and Handkerchiefs; 20,000 spindles; 450 looms; steam.
- GEM KNITTING MILLS; H. S. Brugh, (K) supt.; Men's Cotton Half Hose; 50 knitting machines; steam; finish; sell direct; P. S. Brugh, buyer. (Buy 14, H, 10, 12s cotton yarn.)
- COLUMBIA LACE CO; James Cleland, supt. (C) and buyer; Lace Curtains, Etc; 15 machines; steam; sell direct.
- Conshohocken.** J-15. P. RR, Schuylkill Div, Norristown Br; P. & R. RR, Plymouth Br.
- HALL, JAMES; Aramink Carpet Mills; (W) Venetian and Damask Carpets; 40 looms; steam; dye; sell direct.
- JONES, H. C. CO; THE; Schuylkill Wool. (W) en Mills; \$100,000; Horace C. Jones, pres; John Booth, treas. and supt; Cottonades and Worsted; 4 sets; 150 looms; steam; dye; W. Yelland and Donill, Miller & Co, N. Y., s. agts; H. C. Jones and John Booth, buyers.
- LEE, J. ELLWOOD, CO; \$500,000; Charles (C) Heber Clark, pres; J. Ellwood Lee, treas; Absorbent Cotton, Plain and Medicated Gauze; 25 cards; sell direct.
- Coopersburg.** G-15. Phila. & Read. RR.
- BERGEY, M. B. & Co.; 84 needle Hosiery; (K) 35 knitting machines; steam; sell direct. *See also Souderton.*
- Cooperstown.** D-3. A. V. RR; W. N. Y. & P. RR, Pittsburg Div; L. S. & M. S. RR, Oil City & Andover Line; N. Y., L. E. & W. RR, Bergen County RR, Br. Eastern Div.
- HILLIER, S. B.; Flannels, Blankets, (W) Yarns; 1 set; 4 looms; water; dye.
- Coplay.** G-14. L. V. RR.
- COPLAY KNITTING MILL CO.; J. F. Col. (K) lins. supt.; Ladies' Vests; 6 knitting machines; steam; E. J. Chaffee & Co., s. agts.; A. D. Levay, buyer. (Buy yarn, 22s.)
- Craigsville.** F-3. Armstrong County; A. V. RR.
- Ross, J. ALEX. & Co; J. A. Ross, mgr; (W) Flannels, Blankets, Yarns, Women's Skirts; 3 sets; 17 looms; steam and water; dye; Pittsburg Dry Goods Co, s. agts.
- Cressona.** G-13. Schuylkill Haven branch, Phila. & Reading RR.
- BECK HOSEIERY CO; Wm. H. Beck, treas. (K) and supt; Ladies' Seamless Cotton Hosiery; 32 knitting machines; steam; sell direct; Wm. H. Beck, buyer. (Buy 14, 15, 16 and 17 single yarn and 40s splicing yarns.)
- Crum Lynne.** J-15. W. & B. RR, Maryland Div.
- LONGBOTTOM, S. & Sons; Crum Lynne (W) Worsted Mills; J. H. Longbottom, supt; Worsted Yarns, 20s to 50s (English System); and Wool Tops or Wool Combed on Commission; 5 double worsted cards; 5200 worsted spindles; steam and water; sell direct; J. H. Longbottom, buyer.
- Curwensville.** F-6. B. R. & P., Clearfield & Mahoning Br; P. RR; Tyrone & Clearfield RR.
- MURR, W. A.; Linen Towels, (C, W & L) Table Cloth and Rag Carpets; 10 looms; steam; sell direct. (Buys 14/2 cotton warps and 16 linen yarns.)
- Danville.** F-11. D. L. & W., Bloomsburg Div; P. & R, Catawissa & Williamsport Br.
- DANVILLE KNITTING MILLS CO; Thomas (K) West, treas; Men's Fine Hosiery; 166 knitting machines; steam. (Also see Ashley, Millheim and Plymouth, Pa.)
- HARTMAN, F. Q.; Silk Throwster; 37,000 (S) spindles; steam. (Also Berwick.)
- Darby.** J-15. P. W. & B. RR, Maryland Div; B. & O. RR, Phila. Div.
- GRAYSON, GEO; Dauntless Yarn Mills; (W) Woolen and Merino Yarn; 4 sets; 5400 spindles; steam; dye; sell direct; office, 34 N. Front St, Phila.
- GRISWOLD WORSTED CO (LTD); Frank (W) T. Griswold, treas; W. H. Whiteley, supt; Worsted Yarns (English system) and Spun Silk Yarns; 17 combs; 10,000 spindles; steam; sell direct; Phila. office, 227 Chestnut St.
- VERLENDEN BROS. (Inc); Imperial (W) Mill; \$224,000; W. Lane Verlenden, pres. and supt; Chas. B. Verlenden, treas; Cotton and Woolen Goods; 7 sets; 150 looms; steam; dye; James Tappett, 108-110 Franklin St, N. Y., s. agt; W. Lane Verlenden, buyer. (Buy cotton yarn, 20s, 2/20, 18s, 14s, 12s.)
- WILBY, J. F. & Co; Spinning Yarn; 1800 (W) spindles; 2 sets; steam.
- Dauberville.** G-13. P. & R. RR.
- DAUBERVILLE KNITTING MILLS; (H. K. (K) Phillips, H. M. and H. R. Loose); Ladies' Ribbed Underwear; 5 knitting machines; 5 sleeves; gas.
- Denver.** H-13. P. & R. RR.
- GERLAKE, J. H.; Hosiery. (K)
- WESTERHOFF BROS. & NAPIER CO.; (S) Branch mill; 15 looms;. (Also Ephrata, Pa., and Jamesburg and Paterson, N. J.)
- Dickson.** D-13. (Not shown on map.) R. R. Tankhannock L. V. RR.
- BLISS, VALENTINE; Throwster. (See (S) Scranton.)
- TAYLOR SILK MFG. CO.; 35 looms. (See (S) also Paterson, N. J.)

- Downingtown.** J-14. P. & R. RR, Chester Valley Br; P. RR; Downingtown & Lancaster RR.
- DOWNINGTOWN KNITTING CO; *Burned.* (**K**) *Not resumed.*
- EVANS & WALKER HOSIERY CO; *Out of business.*
- ROCKSTONE MILLS; William Souls' Sons; (**W**) (Main office, 260 W. B'way); F. L. Putney, mgr.; Meltons; 2 sets; 60 looms; dye; sell direct; 43 Leonard St., N. Y.; firm, buyers.
- Doylestown.** H-15. P. & R. RR.
- AVEYARD, WM., & Co; (formerly Doyles. (**W**) town Worsted Co.); Worsted Yarns; 1600 spindles; 24 looms; dye.
- Draco.** K-12. (Two miles N. W. of New Park.)
- KESELING, GEO; Hopell Woolen Mill; (**W**) Blankets, Flannels, Yarns; 1 sets; 2 combs; 3 looms; water; dye; sells direct.
- Du Bois.** E-6. A. V. RR, Low Grade Div; B. R. & P. RR, Buffalo & Pittsburg Div; Clearfield & Mahoning RR.
- REAMS, DAVID; Du Bois Knitting Mill; (**K**) 41 knitting machines; steam. *Mill idl; for sale.*
- Duncannon.** H-10. Penn. RR; P. C. RR.
- FORRY, I. W. & SON; Hosiery. Branch (**K**) of Shamokin, Pa, which see.
- JENIATA KNITTING MILL; Boyd & Jones, (**K**) *Proposed.*
- Dunmore.** D-14. E. & W. V. RR.
- CAMBRIA SILK THROWING MILL; (Val (**S**) Bliss, Scranton.) Silk Throwing; 12,540 spindles.
- PETERSBURG SILK MILL, THE; Reiling, (**S**) David & Schoen; Branch mill; 200 looms; steam. (Also West Hoboken.)
- Duryea.** D-14. D. L. & W. RR.
- DURYEA SILK MILL; Tie Silks; 16 looms. (**S**)
- East Brook.** E-1. W. N. Y. & P, Pittsburg Div; (New Castle Sec.)
- HUTCHINSON, SAM'L; Stocking Yarn, (**W**) Blankets, Flannels; 1 set; 4 looms; water; dye; sell direct.
- East Greenville.** H-15. Perkiomen RR.
- COLUMBIA SILK MILLS; A. S. Schantz, (**S**) mgr; Ribbons; 500 spindles; 31 looms; steam; L. Erstein & Bro. and Kohn, Adler & Co., N. Y., s. agts.
- East March Chunk.** F-14. L. V. RR, Mahanoy Div; Wyoming Div.
- DERY, D. G; (formerly Meding Mfg. Co.); (**S**) Ernest Mill; Silk Throwing and Broad Silks; 10,000 spindles; 150 looms; steam; sell direct, 14 Greene St., N. Y. (See also Catsaunqua.)
- Easton.** G-15. E. & N. RR; C. of N. J. RR; D. L. & W. RR, Morris & Essex Div; L. H. R. RR; L. V. RR, Lehigh Div; New Jersey Div.
- CHIPMAN, CHAS. & SONS; Cotton, (**C** & **K**) Plain, Ribbed and Seamless Hosiery, Fast Black Ladies' Hose Principally; 600 knitting machines; 8,240 cotton spindles; steam; dye; sell direct; Geo. M. Lillie and Wm. V. Parker, N. Y. representatives; F. L. Chipman, buyer. (Buy 40s to 80s.)
- EASTON CORDAGE WORKS; Rope, Etc. (**J**)
- PHILLIPSBURG SILK MILL CO; \$25,000; (**S**) J. W. Stewart, pres; J. W. Wood, treas; B. Haycock, supt; Broad Silks; 137 looms; steam; J. W. Stewart, with S. Peierls & Co., N. Y., s. agts.; B. Haycock, buyer, machinery and mill supplies; J. W. Stewart, raw silk.)
- SIMON, R. & H; see Weehawken; mill at (**S**) Union Hill; Broad Silks; Ribbons, Plushes and Velvets, Silk Throwing; steam and water; sell direct; Herman Simon, buyer; N. Y., office, 63 Greene St.
- East Stroudsburg.** F-15. (RR. station Stroudsburg.) D. L. & W. RR; N. Y. S. & W. RR.
- BLISS, VALENTINE; (Scranton, Pa.); S. R. (**S**) Bliss, supt.; Commission Throwing; 1000 spindles; steam.
- MELROSE HOSIERY MILLS; *Closed. Machinery taken out.*
- POCONO HOSIERY CO. *Closed. Machinery out.*
- Ebensburg.** G-6. C. & C. RR, Ebensburg Br.
- EBENSBURG WOOLEN MILL; J. Ludwig (**W**) & Sons; Cassimeres, Blankets, Flannels, Yarn, Etc; 1 set; 5 looms; steam and water; dye.
- Eddystone.** J-15. P. & R. RR, Phila. & Chester Br; P. W. & B. RR, Maryland Div.
- EDDYSTONE MFG. CO; \$1,000,000; office, (**P**) 130 Chestnut St, Phila.; Lincoln Godfrey, pres; A. C. Pancoast, treas; Peter Hunter, supt; Calico Prints; steam; dye; Wm. Simpson, Sons & Co, s. agts; E. K. Nelson, buyer.
- Eden.** (Bucks County.) H-16. P. & R. RR, Phila. New Line; C. RR. of N. J.
- AMERICAN SILK MFG. CO; \$5000; Felix (**S**) Haac, pres. and treas; A. Markgraff, supt; Raw Silk Products, Machine Wipes, Etc; 8 looms; steam; Felix Haac, buyer; office, 311 Walnut St; Phila. (In plant of Eden Mfg. Co.)
- EDEN MFG. CO; \$50,000; C. M. McCloud, (**S**) pres; Adam Markgraf, supt; Silk Piece Goods, Curtains, Etc; 28 power and 21 hand looms; steam; C. B. Young & Co., N. Y., s. agts; Chas. M. McCloud, buyer. (Buy cotton 30/2 to 40/1 warps, 3/16, 30/2, 10/2 mercerized 10/2 silk Traus and Organzine.)
- Elizabethville.** G-11. N. C. RR; Summit Br. RR.
- ENTERPRISE HOSIERY MILLS; \$25,000; W. (**K**) P. Ingle, pres; C. W. Enders, treas; supt. and buyer; Ladies' Cotton Seamless Hosiery, 176 needle; 62 knitting machines; 8 loopers; 1 trimmer; steam; Frank B. Berlin, s. agt.
- Emaus.** G-14. Perkiomen RR; P. & R. RR, East Penn. Br.
- GUMBINNER, PAUL CO; E. A. Stansfield, (**S**) supt; Dress Silks and Draperies; 500 looms; steam; N. Y. office, 455 & 457 Broadway.
- Emlenton.** E-3. A. V. RR.
- FLYNN BROS; Emlenton Woolen (**W**) Mills; Blankets, Flannels and Skirts; 3 sets; 22 looms; steam; dye; sell direct; Thomas Flynn, buyer.
- Ephrata.** H-13. Phila. and Reading RR.
- WEAVER F. S.; Fine Gauge Half Hose; (**K**) 40 knitting machines; steam; sell direct. (Buy 10s, 11s, 40s and 30s.)
- WESTERHOFF BROS. & NAPIER CO; Eph. (**S**) rata Mill; \$100,000; Peter D. Westerhoff, pres; Henry Westerhoff, treas. and supt; Broad Silks; 2,212 spindles; 200 looms. T. S. Napier, 31 Greene St., N. Y., s. agt; Henry Westerhoff, buyer. (See Jamesburg and Paterson, N. J., and Denver, Pa.)
- Fayetteville.** (RR. name, East Fayetteville.) K-9. Mont Alto, RR.
- WHITE, J. BURNS; Franklin Woolen Mill. *Out of business.*
- Fleetwood.** G-14. P. R. RR, East Penn Br.
- FLEETWOOD MILL; Branch. *See York Silk* (**S**) *Mfg. Co., York, Pa.*
- KUTZ BROS; Clover Leaf Knitting Mill; (**K**) F. S. Kutz, agt; C. W. Kutz, supt; Cotton Half Hose; 41 knitting machines; gasoline; sell direct; F. S. Kutz, buyer. (Buy white, mixed, Egyptian and solid colored yarns.)
- Forest City.** C-14. D. & H. RR; Erie RR.
- HARVEY SILK CO., ALFRED; Box 2; A. (**S**) Harvey, pres.; Jos. K. Harvey, treas. and

- supt.; Silk Throwing, Tram, Organzine, Fringe, Crepe de Chine, Silk Yarns; 6,000 spindles; steam. (Also see Scranton.)
- Forkville**, D.H. (Sullivan County.) W. & N. B. RR.
- FLEMING, JOHN R; Flannels, Woolen (W) Yarns; 1 set; 240 woolen spindles; 2 looms; water.
- Freeland**, E.B. Lehigh Valley RR, Bridge Junction Branch.
- FREELAND SILK MILL CO; \$50,000; E. R. (S) Simpson, pres; F. W. Bleckley, treas; A. H. Bleckley, mgr.; Throwsters; 15,000 spindles; steam; sell direct; A. H. Bleckley, buyer.
- Georgetown**, G.H. N. C. RR.
- ROMBERGER, C. M; Georgetown Hosiery (K) Mill; Ladies' Seamless Hosiery and Men's Seamless Half Hose; 40 knitting machines; 4 ribbers; 3 loopers; steam; S. Hazard Halstead, N. Y., s. agt. (P. O. address, Dalmaria.)
- Gettysburg**, K.10. Phila. & Reading RR, & W. Md. RR.
- RELANCE HOSIERY MILLS; (office 309 (K) Broadway, N. Y.); Hosiery.
- Gladwyne**, J.15. P. RR, Phila. Div.
- BOOTH & BRO; Rose Glen Mills; W. A. (W) L. Barker, supt.; Carpet Yarns; 7 sets; steam; sell direct; W. A. L. Barker, buyer.
- HUMPHREYS, SETH; Enos Humphreys, (W) supt.; Carpet Yarns; 4 sets; steam and water; sell direct.
- Glen Riddle**, J.15. P. W. & B. RR, Central Div.
- GLEN RIDDLE MILLS. Reported purchased (W) by John Dobson.
- Glen Rock**, K.H. N. C. RR, Balto. Div.
- HANNAGAN, J. F; Rag Carpets; 2 hand (W) looms. (Buys 2 and 3 ply linen, 3 ply wool and 2, 3 and 4 ply cotton yarns.)
- HEATHCOTE, L. K, & Co; Cassimeres, (W) Flannels, Felting, Blankets, Etc; 2 sets; 12 looms; steam and water; dye; sell direct.
- RADCLIFFE & SHAW; Squire Bamforth, (J) supt.; Jute Rope and Jute Twines; American Hemp Twine and Sash Cord; steam; sell direct.
- Gordon**, F-12. P. & R. RR.
- EAGLE HOSIERY MILL; Wm. G. Johnson, (K) supt.; Misses' Ribbed and Men's Half Hose; 80 knitting machines; steam; sell direct and Watson Porter Giles & Co., s. agts.; W. J. Fling, buyer. (Buy 12, 15 and 8 yarn.)
- Gonglersville**, H-13. R. & S. (Electric) RR.
- FISHER, RICHARD; Hosiery Knitter. (K)
- Greencastle**, K.S. Cumberland Valley RR.
- LEIGNERITZ, GEO. W, & Co; Woolens; 1 (W) set; 4 looms.
- Greenville**, D.1. (Mercer County.) N. Y, L. E. & W. RR, Eastern Div; P. RR; Erie & Pittsburg RR; P. S. & L. E. RR.
- PEARCE, JNO, & SONS; Blankets and (W) Flannels; 3 sets; 30 looms; steam; dye; Pittsburg Dry Goods Co., s. agts.; W. A. Pearce, buyer.
- Grill**, H-13. R. & S. (Electric) RR.
- YOCOM, HARRY Y; Speedwell Knitting (K) Mill; Cotton Half Hose; 25 knitting machines; steam and water; sell direct; R. Van Chief Smith, 302 B'way, N. Y., representative. (Buys solid colors in 188; silvers, jagers and mixes, 208; white, 208.)
- Gulf Mills**, J.15. See Conshohocken.
- Hallstead**, B-13. D. L & W. RR; Northern Div. & Erie RR; Susquehanna, No. Div.
- HALLSTEAD TEXTILE CO. Out of business. (S Mill for sale.)
- Hamburg**, G.E. Penn. RR.
- BAUSHER S. D; Gotham Knitting (K) Mills; C. Yeager, supt.; Ladies' Cotton Ribbed Underwear; 16 knitting machines; 30 sewing machines; steam; L. P. Naylor & Co. and F. M. Farber & Co, s. agts; S. D. Bausher, buyer.
- CRYSTAL SPRING DYE & BLEACH (D & B) WORKS. See Shoemakersville.
- HAMBURG BLEACH WORKS; Capacity, (B) 2000 lbs. per day.
- HAMBURG KNITTING MILLS; T. M. Raub (K) enhold, supt.; Ladies' Cotton Ribbed Underwear; 12 knitting and 13 sewing machines; steam; Roger Lamson & Co, s. agts. (Buy yarns 22s on cones.)
- KNAUSE, H; Knause Bleachery; All (B) Kinds of Knit Goods.
- Hanover**, K.10. P. W. M. RR, Balto. and Harrisburg Div.
- BONTE CORDAGE CO, LTD; \$50,000; Geo. (B) H. Bonte, pres; Frederick W. Weber, treas; John Greenaway, supt.; Hemp and Jute Twines and Cordage, Spun Yarn, Etc.; 300 spindles; steam; sell direct.
- HANOVER SILK CO; Geo. D. Gitt, (S) pres; Thos. J. O'Neill, sec. and gen. mgr. Ribbons; 50 looms; steam; Harlt Von Bernuth & Co. N. Y. s. agts.; T. J. O'Neill, buyer. (Buy 2/30-2/60 bleached white and colors, Sea Island cotton; Egyptian and mercerized.)
- Harrisburg**, H.H. C. V. N. C. RR, Balto. Div, Susquehanna Div; P. RR, Middle Div, Phila. Div; P. & R. RR, Lebanon Valley Br, Schuylkill and Susquehanna Br, Steelton Br, Harrisburg and Pittsburg Line.
- HARRISBURG KNITTING MILL; D. H. (K) Howes, supt.; 136 and 176 needle Men's Half Hose; 45 knitting machines; steam. (Buy cotton yarns, 9, 10, 12 13, 30, 50, 60.)
- PELGRAM & MEYER (Paterson, N. J.); (S) Charles Soleiac, supt.; Broad Silks and Ribbons; 400 broad silk and 50 ribbon looms; steam; sell direct, 113-15 Spring St., N. Y.
- ROSENBERGER, J. W. & SON; Rag, Jute (W) and Yarn Carpets; 14 looms; steam and hand power; sell direct.
- Hawley**, D-15. E. & W. V. RR, N. Y, L. E. & W. RR.
- BELLMONT SILK MILLS; Dexter Lambert (S) & Co; also Honesdale and Paterson, N. J.; W. F. Suydam, mgr.; Thrown Silk, Tram and Organzine, Ribbon and Piece Goods; 3000 spindles; 50 looms; water; C. A. Auffmordt & Co, N. Y., s. agts.
- MEDERER BROS; Throwsters. (S)
- UNITED STATES KNITTING MILLS; H. (K) Nollan, prop; Cotton, Wool Worsted, Silk Sweaters; Toques, Hunting Jackets, Golf Leggings and Cardigan Jackets; 26 knitting machines; sell direct. (Buy wool, worsted and cotton yarn.)
- UNITED STATES KNITTING MILLS CO; (K) \$40,000; Geo. A. Smith, pres; Geo. F. Simons, treas; Ernest H. Ludwig, supt.; Ladies', Men's and Boys' Sweaters, Golf Leggings, Cardigan Jackets, Knit Shirts and Toques; 22 knitting machines; steam; sell direct and H. Lee Mallory N. Y., agt; E. H. Ludwig, buyer. (Buy 2/20 wool, 2/15, 4/19, 2/26 worsted and 2/12 cotton yarn.)
- WAYNE CO. KNITTING MILLS; C. J. (K) Schlager, prop.; Sweaters and Cardigan Jackets; 9 knitting machines; sell direct.
- Hazleton**, F-13. Lehigh Valley RR.
- DUPLAN SILK CO.; (See S. Bethl hem.)
- HAZLE KNITTING MILLS CO.; \$30,000; (K) A. L. Dunn, pres.; W. H. Kemp, sec.; H. W. Jacobs, treas.; Horace C. Gabell, gen'l mgr and buyer; Ladies' Ribbed Underwear; 18 knitting machines; steam; H. S. Unger, 43 Leonard St., N. Y., s. agt. (Buy carded and combed and hste 8s to 268.)

ROESSEL, LOUIS & Co; Hazelton Silk (S Mill; Jas. Wm. E. Speirs, Jr, supt; Umbrella Silks; 328 spindles; 58 looms; steam; finish; sell direct; 113 Grand St., N. Y. (Also Washington, N. J.)

WILDE & Co; Ladies' Fine Ribbed (K Vests; 10 body machines.

WILLIAMS, T. A. & Co; (mill at West (K Hazelton); Misses' Hosiery; 14 knitting machines; steam; T. A. Williams, buyer. (Buy Eastern cotton, 10.9.)

**Hellertown.** G-15. P. & R. RR, Bethlehem Br.

CARRIE KNITTING MILL; R. C. Hittell, (K agt., supt. and buyer; Ladies' Cotton Ribbed Underwear, Straight and Shaped; 16 knitting machines; steam; Critten Clift & Co, N. Y., s. agts. (Buy 10/1 and 20/1 carded peeler on cones.)

**Hickox.** B-8. B. & S. RR.

MARBLE, L. D. & Sox; Perryville Woolen (W Mill; Chas. Marble, supt.; Filled Cloth and Flannels; 1 set; 2 looms; water; dye; sell direct; A. L. Marble, buyer.

**High Spire.** H-11. P. RR, Phila. Div.

GOOD, MARTIN; A. Bucher, (W & K supt; Cassimeres, Flannels, Yarns, Blankets, Carpets, etc.; 1 set; 7 looms; water and gas; dye; sell direct; Martin Good, buyer. (Buy cotton carpet warp in 5 ply and 4 ply.)

**Holidaysburg.** H-7. P. RR, Holidaysburg Br.

SCHWARZENBACH, HUBER & Co.; (Branch (S of Throwing mill at Altoona, Pa.); Robt. Brubacher, supt.; Throwing; steam. (See also West Hoboken, N. J.)

**Hollisterville.** D-14. E. & W. V. RR.

FESSENDEN, FLOYD; Woolens; 1 set; (W water.

**Honesdale.** D-15. D. & H. RR; Gravity RR; N. Y. L. E. & W. RR, Honesdale Br.

AMERICAN KNITTING Co; \$10,000; Phillip (K Krantz and others.

BIRDSALL BROS.; C. A. Parfy, supt.; (W Woolens, Blankets, Pants, Shirts and Yarns; 2 sets; 18 looms; water; dye; sell direct; J. C. Birdsall, buyer.

DEXTER, LAMBERT & Co; Throwsters and (S Weaving Ribbon and Dress Silks; 125 looms; steam. (Also Hawley and Paterson, N. J.)

MAPLE CITY KNITTING MILLS; John Reif, (K let, pres.; L. B. Guckenberger, sec.; Fred Hardler, supt.; Wool and Fancy Sweaters and Cardigan Jackets; 10 knitting machines.

**Houersville.** F-8. P. RR; Bellefonte, Nittany & Leimont RR; Lewisburg & Tyrone RR.

KELLER, G. S; Yarns, Blankets and (W and Flannels; 1 set; 5 looms; water; dye; sell direct.

**Huberville.** J-16. P. RR, Trenton Cut-off; P. & R. Phila. New Line.

FRICKE, J. E. Co; \$100,000 (all paid); Ino. (C E. Fricke, pres.; W. S. Fricke, treas.; W. Smith, supt; Rope and Twines; 2500 spindles; steam and water; sell direct; New York and Chicago; J. E. Fricke, buyer; office, 255 Market St, Phila.

GARSED, JOHN; Cotton Rope, Braid, (C Spindle Binding; steam; finish; sell direct.

REETZ, EWALD R.; Hair Cloth; 40 looms; (C steam; dye; sell direct; Ewald R. Reetz, buyer. (Buy 14 single, 36-2 ply and 20-3 ply cotton yarn.

**Hummelstown.** H-11. P. R. RR, Lebanon Valley Br; Middletown & Hummelstown Br.

HUMMELSTOWN HOSIERY Co; \$5,000; J. (K J. Nissley, pres; U. L. Balsbaugh, treas;

Geo. P. Hoffer, supt; Seamless Half Hose; 40 knitting machines; 2 sewing machines; steam; Sellers & Steele, N. Y. and Pittsburg, s. agts; Geo. P. Hoffer, buyer. (Buy 108 white cones.)

ULRICK & KNILL; Keystone Knitting (K Mills; Cotton Seamless Half Hose; 44 knitting machines. Buy 18, 20, 30 yarns; John M. Given, N. Y., s. agt.

**Huntingdon.** H-8. H. & B. T. RR; Penn. RR; Harrisburg Br.

FUNK, HARVEY E; Fine Gauge Half Hose; (K 30 knitting machines; steam; W. Baxter Thompson Co., N. Y., s. agts.; Harvey E. Funk, buyer.

**Indiana.** G-4. Penn RR.

INDIANA WOOLEN MILLS Co.; \$35,000; (W J. H. Engle, pres.; James M. Watt, treas.; J. A. Findley, sec; J. S. McElhoes, supt; Blankets, Skirts, Flannels and Yarn; 2 sets; 14 looms; steam; dye; sell direct; J. S. McElhoes, buyer.

**Jermyn.** D-14. D. & H. RR; N. Y. O. & W. RR.

MAXWELL THROWING Co; R. T. Maxwell, (S pres; Andrew Mitchell, Jr, treas; Commission Throwsters, Tram and Organzine a Specialty; 3,500 spindles; steam.

**Kingston.** D-13. (Not shown on map.) D. L. & W. RR.; L. V. RR.

MORGAN, Wm. P. See *Wilkes Barre.* (K)

**Kutztown.** G-14. P. & R. RR, Allentown Br.

DEISBER, H. K; King Knitting Mill; (K Ladies', Children's and Men's Ribbed Cotton Underwear; 14 knitting machines; steam; sell direct; G. F. Coward, Pittsburg, Pa., salesman; H. K. Deisher, buyer. (Buy 9 to 25s carded and combed Peeler and Egyptian yarn.)

KETZTOWN SILK THROWING MILLS; Thos. (S E. Pahner, mgr.; Organzines, Trams, Fringes, etc; 7200 spindles; team.

**Lancaster.** J-12. L. & R. RR, Lancaster Br; P. RR; Downingtown & Lancaster RR.

CONESTOGO STEAM MILLS; John Farnum (C & Co; Ticks, Chevits, Sheetings, Awnings; 24,608 spindles; 760 looms; steam; dye; sell direct at 255 Chestnut St., Phila.

SCHUM, PHILIP, SON, & Co; Coverlets, (W Blankets, Carpet Yarn; 1 set; 10 looms; steam; dye.

STEHLI & Co; E. H. Barlow, N. Y. agt; (S Dress, Tie and Lining Silks; 500 looms.

**Landenburg.** K-14. B. & O. RR, Landenburg Br; P. RR, Pomeroy & Newark Br.

LUND, EZRA; Landenburg Worsted (W Mills; Worsted Yarns (English System); 2556 spindles; 4 combs; 2 sets; steam; sell direct.

**Langhorne.** See *Huberville*

**Langville.** E-4. A. V. RR, Low Grade Div.

LANG, JOHN; James F. Skinner, supt.; (W Cassimeres, Blankets, Yarns, Flannels and Shirtings; 1 set; 1 narrow and 2 broad looms; steam and water; dye; sell direct; John Lang, buyer.

**Lansdale.** H-15. Phila. & R. RR, and S. C. RR.

LANZA SILK Co; \$25,000; J. M. C. Speirs, (S pres; John B. Price, treas; F. W. Bleckley, sec; Jas. M. C. Speirs, supt. and buyer; Black Umbrella and Dress Silks; 39 looms; steam; sell direct.

**Lansdown.** J-15. Phila. W. & B. RR.

HALL, W. & Co; Albert Booth, (W supt; Woolen Shoddy and Backing Yarn; 7 pickers; 14 cards; 4 garnett machines; steam; dye; sell direct. MH at Fernwood.

**Leban n.** H-12. (Not shown on map.) C. & L. RR., P. & R. RR.

FASHIONED HOSIERY MILLS; Simon P. (K Light and others; Knit Goods All Kinds,

- Hosiery and Underwear; about 160 machines. *Proposed.*
- MILLER & WARD (branch mill); Broad (S) Silks; 40 looms. (See also Paterson, N. J.)
- Leesport.** G-13. P. & R. RR; P. RR, Phila. Div.
- MILLER & BALTHASER; \$12,000; C. M. (K) Balthasar, pres. and supt.; S. L. Miller, treas.; Fine Seamless Half Hose and Misses' Fine Rib Hose; 30 knitting machines; steam; sell direct; 39 Franklin St., N. Y.; C. M. Balthasar, buyer. (Buy yarns, 12, 16 and 22.)
- Lehighton.** F-14; Central RR. of N. J. Lehigh Valley RR.
- BAER, EUGENE & Co; Throwing Silk; (S) 11,000 spindles; steam; Eugene W. Baer, buyer.
- HELVETIA SILK MILL; All Widths Satin (S) Back Velvet Ribbons; Fred'k Victor & Achelis, N. Y., s. agts. (See Paterson Mill.)
- Leoni Mills.** (RR. name Leoni.) J-15. P. W. & B. RR, Central Div. Chester Creek Line.
- CARSON, WILLIAM & Co; Brookside (W) Mills; Worsteds and Cassimeres; 5 sets; 100 looms; steam and water; dye; Jas. Talcott, N. Y., s. agt.
- LEES, DANIEL; Plushes and Velours; 20 (S) looms; steam and water; sell direct.
- Le Raysville.** C-12. (RR. Station, Wysox).
- HAIGH, J. F; Yarn, Shirting, Blank (W) ets, Cassimeres; 1 set; 2 broad and 2 narrow looms; 1 knitting and 1 sewing machine; water; sell direct. *Mill closed.*
- Lewisburg.** F-11. P. RR; Lewisburg & Tyrone RR; P. & R. RR, Sham, Sunbury & Lewisburg Br.
- LEWISBURG WOOLEN Co; \$60,000; W. (W) A. Schreyer, pres.; J. Y. Schreyer, treas.; Fancy Cassimeres; 3 sets; 18 looms; steam; dye; H. & W. H. Lewis, s. agts.; W. S. Halfpenny, buyer.
- MUSSER, JOS. & SONS; Australian Sax. (K) ony and combed Egyptian Hosiery; 130 cylinders; 55 knitting machines; steam; finish; sell direct. (Buy yarns.)
- Lewistown.** G-9. P. RR.
- LEWISTOWN KNITTING Co; Thompson (K) Bros; Men's and Ladies' Worsteds Hosiery; 91 knitting machines; steam; Fred'k Victor & Achelis, s. agts. (Buy 20s to 45-French System Worsteds Yarns, cotton mule spun, 12 to 40s.) (*Also Millroy.*)
- Listonburg.** K-4. B. & O. RR; Confluence & Oakland RR.
- LISTON, JESSE; Blankets, Flannels and (W) Yarns; 2 sets; 4 looms; 1 knitting machine; steam and water; dye; sell direct.
- Lititz.** J-12. Phila. & Read, RR.
- KAUFFMAN KNITTING MILLS; (formerly (K) Lititz Springs Knitting Mills); Ladies' Jersey Ribbed Underwear; 12 knitting machines; 23 sewing machines; steam; finish; Critten, Cliff & Co., N. Y., s. agts.
- KEYSTONE UNDERWEAR MILLS; \$10,000; (K) Sam'l B. Erb, pres; Adam B. Loud, sec; Israel G. Erb, treas; F. B. Buch, supt. and gen'l. mgr; Men's cotton Ribbed Underwear; 20 knitting machines; 28 finishing machines; steam; Sutton & Co; 55 Leonard St., N. Y., s. agts; F. B. Buch, buyer.
- Lock Haven.** E-9. Penn. RR.
- LOCK HAVEN SILK Co; F. G. Yorks, prop; (S) August Schnell, supt. and buyer; Dress Goods; 250 looms; steam; Fleitman & Co, N. Y., s. agts.
- Lockport Station.** (RR. name, Lockport.) H-5. P. RR, Pittsburg Div.
- CLAYTON, THOMAS; Flannels, Blankets (W) and Yarns; 1 set; 4 looms; water; dye; sell direct.
- Lutzville.** J-6. P. RR, Bedford Div.
- LUTZ, DAVID T.; Cassimeres, Sati- (W) nets, Knitting Yarns, Blankets; 1 set; 4 looms; 2 knitting machines; water.
- Lykens.** G-11. N. C. RR. and W. V. RR.
- DUNCAN, WALTER, & Co.; W. W. Duncan, (K) supt.; Ladies' Fine Hosiery; 42 knitting machines; steam; J. Van Wyck Dubois, s. agt.; R. Coble, buyer. (Buy 12s, 14s, 15s and 40s mule spun yarn.)
- FISHER & JONES; \$20,000; E. P. Jones, (K) supt.; Plain and Fancy Half Hose; 176 needle; 40 automatic knitting machines; 8 ribbers; steam; sell direct; Ed P. Jones, buyer. (Buy 12s, 14s and 40s cotton yarns on cones, also 20 and 40s 2 ply silkateen on cones.)
- KEES & KNILEY; Black Diamond Mill; (K) Cotton Half Hose; 70 knitting machines; steam; Thomas S. Fuller, 70 & 72 Franklin St., N. Y., s. agt. (Buy carded Peeler, 10s, 12s, 15s, 40s.)
- Lyndell.** (RR. name, Brooklyn.) J-14. P. RR; Downingtown & Lancaster RR.
- EASTWOOD, J. B. & Co; Brooklyn (W) Woolen Mills; Kentucky Jeans and Doeskins; 2 sets; 56 looms; water; M. Brown, Sons & Co, s. agts.
- Lyon Station.** G-14. P. & R. RR.
- MADEIRA & WANNER; Seamless Hosiery, (K) Seamless Half Hose a Specialty; 10 machines.
- Macungie.** G-14. P. & R. RR, East Penn. Br.
- MOYER, R. F. & Co; Valley Hosiery (K) Mill; Cotton Hosiery and Ladies' Underwear; 50 knitting machines; 6 loopers; 6 finishing machines; 6 sewing machines; steam; sell direct and L. J. Riggins, 47 and 49 White St., N. Y., s. agt. (Buy hosiery yarn, 1/2 mix 6 to 11, and whites, 6-9-11, underwear yarn, 9 to 22.)
- Mahanoy City.** F-13. P. & R. and L. O. RRs, Mahony Div.
- JOHNSON, W. G. *See Garlon, Pa.*
- Maiden Creek.** G-13. P. & R. RR.
- MAIDEN CREEK HOSERY Co; \$5,000; (K) Franklin Seidle, pres.; Solomon R. Roth-enfel, treas.; Wm. H. Brasch, supt.; Intants' Hosiery; 19 knitting machines.
- Manheim.** J-12. P. & R. RR.
- LONG, S. M; Manheim Hosiery Mills; (K) C. S. Witmyer, supt; Cotton Half Hose, 108 and 176 needle; 38 knitting machines; steam; sell direct; S. M. Long, buyer. (Buy No. 13 combed Egyptian on cones.)
- Mansfield.** C-10. N. Y. L. E. & W. RR, Tioga Br.
- MANSFIELD WOOLEN Co. (formerly Stra- (W) cham, Mfg. Co.); James Strachan, mgr. and supt.; Ladies' Wear; 32 looms; steam; Sack & Stastny, s. agts.
- Maria.** H-6. See Woodbury. P. RR, Mor. Cove Br.
- CLOUSE, W. H.; Sam'l Keagy, supt; (W) Cassimeres, Flannels, Blankets, Yarns, Etc; 1 set; 9 looms; water; dye; sell direct.
- Marietta.** J-12. P. RR, Columbia Br.
- ASHLEY & BAILEY; Dress Silks; 200 (S) looms. See Columbia and Coatsville, Pa., Fayetteville, N. C. and Paterson, N. J.
- McAley's Fort.** G-8. P. RR, Middle Div.
- GIBBONEY, B. A.; Blankets, Cassimeres, (W) Flannels and Jeans; 1 set; 6 looms; 2 knitting machines, water; dye; sell direct.
- Meadville.** C-2. Erie RR.
- MEADVILLE SILK MFG. Co.; (Partnership) (S) Otto Meurer, Jr. and Johnson Barbour; David Isaac, supt.; Taffetas, Surahs, Peau de Soi, Etc., Plain Goods; 54 broad looms;



- electricity; Fred'k Victor & Achelis, N. Y., s. agts.; Johnson Barbour, buyer.
- Mechanicsburg.** H-10. Cumberland Valley RR.
- MECHANICSBURG HOSIERY MILL. *Removed (K) to Wagnersboro, which see.*
- VALLEY HOSIERY CO; C. Sherman Grove (K) supt.; Half Hose and Infant's Hosiery; 56 knitting machines; steam; R. Pinder, buyer; C. Sherman Grove, buyer. (Buy combined Egyptian 24/2, 28/2, 32/2, 40/1, Silk 24/2, 28/2, 50/1.)
- Mercer.** E-2. W. N. Y. & P. RR, New Castle Sec; P. S. & L. E. RR.
- BROADBENT, AMMON, Estate of; Jeffer- (W) son Woolen Mills; H. A. Broadbent, mgr. estate; Flannels, Yarns, Etc; 1 set; 3 looms; water; dye. *Not running.* (P. O. address, Kile.)
- Middletown.** H-II. Penn. RR; Phila. & Read. RR.
- ROMBERGER, H. A.; 1826 No. 22nd St, Phila.; (K) D. M. Romberger, supt; High Grade Cotton Half Hose; 138 knitting machines; 30 loopers; 10 sewing machines; steam; S. W. Smack, N. Y. s. agt; H. A. Romberger, buyer. Buy yarns No. 11, 12, H, 16, 22, 30 and 40s.) (Also Newport, Pa.)
- Mifflintown.** G-9. S. & L. RR.
- KARL & SCHOTT; Ladies' Hose and Men's (K) Half Hose (Seamless); 35 knitting machines; steam; sell direct; firm, buyers. (Buy yarns No. 7 to 60.)
- KAUFMAN & HARLEY; Juniata Car. (W) pet Mills; Rag, Domestic and Jute Carpets; 12 looms; gasoline; sell direct. (Buy 4/3/4, 3/8, 2/4 and 3 ply common also carpet wool yarns.)
- Milford Mills.** J. 14. Penn. RR.
- MILFORD HOSIERY CO; \$10,000; W. R. (K) Roberts, pres.; W. D. Fleming, treas.; Cotton Hosiery; 16 knitting machines; steam; dye; sell direct. (Buy is to 24s cotton yarn.) (R. R. Station Lyndell.)
- Millersburg.** G-10. N. C. RR, Susquehanna Div; Summit Br. RR.
- KLINE, GEO. W.; Rag and Jute Carpets; (W) 9 looms; hand power; sell direct; Geo. W. Kline, buyer. (Buy 4/4, 4/8 and 3/4 cotton yarn.)
- Milheim.** F-9. Ry. Station Coburn, Penn. RR.
- CENTRAL KNITTING MILLS CO; Thomas (K) Walter, West, supt.; Fancy Half Hose; 84 knitting machines; 15 ribbers; steam; sell direct. (Also Danville, Pa.)
- Milwton.** J-14. 4 miles from West Chester.
- DUTT, CHRISTIAN & SON; Woolen Yarns; (W) 1 set; water.
- Millville.** E-11. C. P. & W. RR.
- ENTERPRISE WORSTED CO; (formerly (W) Millville Worsted Co); Edward Thorpe, mgr; Worsted Yarns; (Bradford System); 2 sets; 2 combs; 1440 spindles; steam and water; A. T. Sherry & Co., N. Y., s. agts.
- Milroy.** G-9. P. RR, Mifflin & Centre County RR.
- THOMPSON BROS; Cotton, Worsted and (K) Mercerized Hosiery; 88 knitting machines; steam and water; dye; Fred'k Victor & Achelis, N. Y., s. agts. Buy various sizes yarns.) (Also Levistown.)
- Milton.** F-11. P. RR; Sunbury and Driftwood RR; P. & R. RR, Catawissa & Williamsport Br, Sham Sunbury & Lewisburg Br.
- HENRY, THOS., JR., & Co.; W. B. Wilhelm, (C) pres.; James B. Wilhelm, sec.; M. Lieberman, treas.; Thos. Henry, Jr., supt.; Double Roving White and Colored Hosiery Yarns.
- WEST BRANCH HOSIERY CO; \$32,000; Wm. (K) W. Huth, pres; M. Lieberman, treas.; James Campbell, supt; Ladies' and Children's Seamless Hose and Seamless and Full Fashioned Half Hose; 126 knitting machines; steam; dye; sell direct; M. Lieberman, buyer.
- Minersville.** G-12. L. V. RR; Peoples RR; Phila. & Read. RR.
- LEWIS, J. D. & SONS; Ladies', Misses' (K) and Children's Fine Jersey Ribbed Underwear in Cotton, Lisle and Mercerized; 30 knitting machines; steam; Roger Lamsun & Co., N. Y. s. agts.
- Mohn's Store.** H-13. (RR. name Mohnsville.) R. & S. (electric) RR.
- BEAU IDEAL KNITTING MILLS; Kring & (K) Steffy; Men's Cotton Half Hose in Assorted Colors; 84 needle; 27 knitting machines; gasoline; Mamie & Co., and O. A. Potts & Co., s. agts. (Buy cotton yarns on cones, 68, 78, 88, 108, white, 14s mixtures, 3s 27s job yarns.)
- GLOBE HAT CO; Isaac S. Spatz, pres. (W) and treat; A. S. Hornberger, sec; Frank Stichter, supt; Wool Hats; 2 sets; steam and water; dye; C. H. Tenney & Co., N. Y., s. agts.
- INDUSTRIAL HOSIERY MILLS; Seamless (K) Cotton Hose and Half Hose; 72 knitting machines; 1 sewing machine; steam; dye; sell direct; G. H. Leininger, buyer. (Buy yarn) (Mill at Mohnsville.)
- KESSLER, JACOB C. & Co; Wool Hats; 3 (W) sets; steam and water; dye; C. H. Tenney & Co., N. Y., s. agts.
- LEININGER, WM. G.; Cotton Seamless (K) Half Hose; 144 needle and 84 needle; 70 knitting machines; steam; sell direct. (Buy 68, 88, 108 white and mixtures, 6, 8 and 10.)
- SPATZ, J. H. & Co; Samuel Bobst, supt; (W) Wool Hats; 6 sets; steam; dye; C. H. Tenney & Co., N. Y., s. agts.
- WORLEY BROS; Wool Hats; 3 sets; steam (W) and water; dye; C. H. Tenney & Co., N. Y., s. agts.
- WORLEY HOSIERY CO; Men's Half Hose; (K) 144 needle; 22 knitting machines; steam; dye; F. B. Berlin, N. Y., s. agt.
- WYOMISSING HOSIERY CO; Isaac S. (K) Spatz, treas; A. S. Hornberger, supt; Men's Half Hose, 84 Needles, and Misses' Fine, Gauge, Ribbed Hosiery; 100 knitting machines; steam; dye; sell direct; A. S. Hornberger, buyer. (Buy 6s to 22s.) (Also Branch at Reynolds, Pa.)
- Mohrsville.** G-13. P. RR, Schuylkill Div; P. & R. RR.
- MOHRVILLE KNITTING MILLS; Ladies' (K) Ribbed Underwear; 12 knitting machines; 20 sewing machines; steam. (Leased by James H. Wagner & Co.)
- READING COTTON BATTING CO.; (J28 Pean (C) St., Reading, office); J. C. Reed, supt.; Cotton Batts; 5 cards; water; sell direct.
- WAGNER, JAMES H. & CO; Crown Knit. (K) ting Mills; James H. Wagner, supt.; Ladies' Extra and Regular Size Underwear; 11 body frames; 5 sleeves; 19 finishing machines; steam; A. D. Schveder, 60 White St., N. Y., a. agt.; James H. Wagner, buyer.
- Montrose.** C-13. D. L. & W. RR, Montrose Br. Montrose RR.
- MOTT, J. W.; Flannels and Yarn; 1 set; (W) 5 looms; water; dye; sell direct.
- Mordansville.** E-12. B. & S. RR; D. L. & W. RR, Bloomsburg Div; P. & R. RR, Bloomsburg Br.
- SANDS, C. L. & Co; \$10,000; C. L. Sands, (W) pres; J. E. Sands, treas; W. R. Hagenbach, agt; Blankets, Flannels and Yarns; 2 sets; 5 looms; water; dye; sell direct.
- Mount Holly Springs.** J-10. Phila. & R. RR.
- MT. HOLLY HOSIERY CO; Carl G. Kirsch, (K) pres. and treas; Men's, Women's and Chil-

- men's Cotton Hosiery; 36 knitting machines; 2 sewing machines; steam; sell direct; C. G. Kirsch, buyer. (Buys yarn, white, 8, 10, 11, 12 and 16, Egyptian, 10 and 11 and Oxford and French, 8 and 10.)
- Mount Joy.** J-12. P. RR, Phila. Div.
- BROWN'S, GEO. SOONS;** Cottonades, (W) Cotton Worsteds, Flannels, etc.; 5 sets; 176 looms; steam; dye; J. L. Bailly & Co, N. Y., and Phila., s. agts. (Buy cotton yarns 20s to 30s, single and 2 ply; cotton warps, 16s to 40s, single and 2 ply.)
- STAGER, H. L.;** Coverlets, Carpets, Etc; (W) 4 looms; steam; dye; sell direct; H. L. Stager, buyer. (Buy carpet yarns, No. 6 Twist and 2/10, 2/12, 3/14.)
- Muncy.** E-11. P. RR, Sunbury and Driftwood Line; P. & R. RR, Catawissa & Williamsport Br.
- MUNCY WOOLEN MILLS CO.;** \$70,000; Jas. (W) Coulter, pres. and supt; Geo. H. Rogers, treas; Woolen Blankets; 3 sets; 20 looms; steam; dye; sell direct.
- Myerstown.** H-12. Phila. & Reading RR.
- SHERK, JOHN N.;** Fine Half Hose; 10 (K) knitting machines; steam; sell direct.
- SOUDER, JOHN T.;** Carpet Weaver. (W)
- Nanticoke.** E-13. C. R. of N. J.; Penn. RR.
- BARRALL, PAUL.;** Nanticoke Knitting (K) Mill; Wm. Marville, supt.; Kadies' Lace Hose, Fine Gauge, 216 needles; 17 knitting machines; steam; Dalsumer & Kahn, s. agts.; Paul Barrall, buyer. (Buy 1s both com. and 2 ply Egypt, 2/36.)
- BLACK DIAMOND KNITTING MILLS CO.;** (K) Thomas West, treas. and supt; Cotton Hosiery; 100 knitting machines; steam. (See also Plymouth, Pa.)
- Nazareth.** F-15. B. & P. RR.
- KRAEMER, H.;** Seamless and Full Fash. (K) ioned Hosiery; 180 knitting machines; steam; dye; A. J. B. Tait, N. Y., and L. Neebe, Boston, s. agts.
- NAZARETH MFG. CO.;** L. Kraemer, (K) pres; L. F. Kraemer, treas; G. A. Schneebeli, supt. and buyer; Children's Knit Waists; 60 knitting machines; 150 sewing machines; steam; M. W. Schneebeli, 52 Leonard St., N. Y., s. agt.
- SCHNEEBELI, G. A. & CO.;** R. E. Schnee. (C) bel, supt; Edgings for Underwear; 50 looms; buy silk and 3-ply cotton yarn; steam; Geo. W. Chapin, Phila., s. agt.; G. A. Schneebeli, buyer. (Buy 2/3 to 2/80 cotton and mercerized yarn.)
- Nescopeck.** E-12. P. RR, Troy & West Br; Sunbury Div; also from Berwick.
- STEVENSON, JOSEPH.;** Woolens and (W) Yarns; 1 set; 5 looms; water; dye.
- New Berlinville.** H-14. P. & R. RR, Colebrookdale Br.
- FISHER, NICHOLAS J.;** Woolens; 2 sets. (W)
- Newberry.** E-10. Pa. RR; Pa. and R. RR.
- HOLMES SILK CO. See Williamsport.**
- New Bethlehem.** F-4. Pa. RR.
- PONTEFRACT, JAMES & CO. (formerly at (K) Bell's Landing);** James Pontefract, supt.; Woolen Yarns, Flannels and Blankets; 2 sets; 6 looms; steam; dye; sell direct.
- New Brighton.** F-1. B. V. T. Co. RR; P. RR, Eastern Div; P. & L. E. RR
- BENTLEY & GERWIG, LTD.;** \$200,000; N. (F) J. H. Gerwig, pres; Jos. Bentley, treas; A. Bentley, supt; Hemp and Flax Twine; 1000 spindles; steam and water; dye; sell direct; Pittsburg and Chicago; Joseph Bentley, generally buys.
- New Cumberland.** H-11. N. C. RR, Balto. Div.
- BETTORFF & KLINE.;** Rag Carpets; 12 (W) looms; sell direct.
- NEW CUMBERLAND KNITTING CO.;** J. J. (K) Baughman, pres. and treas; H. J. Baugh-
- man, supt; Ladies' and Children's Hosiery and Men's Cotton Half Hose; 68 knitting machines; steam; J. H. Conover, N. Y., s. agt; J. J. Baughman, buyer. (Buy colored peeler 10s/1, 25s/1 and 40s/1 cones.)
- SUSQUEHANNA WOOLEN CO.;** \$50,000; (W) Jos. J. Baughman, pres.; Geo. H. Reiff, treas.; Jos. J. Baughman, supt. and mgr.; Woolen Blankets; 1 set; 17 looms; steam; dye; sell direct; Geo. H. Reiff, buyer.
- New Holland.** J-13. Penn. RR.
- NEW HOLLAND SILK MILL.;** J. R. Frame, (S) supt; Broad and Tie Silks, Novelties, etc.; 100 looms; steam; Hardt, Von Bernth & Co, N. Y., s. agts. *Not running.*
- New Hope.** H-16. Phila. & Reading RR.
- SIMPSON & CO.;** Ernest Barber, supt; (S) Silks; 48 looms; steam; A. D. Juilliard & Co, s. agts. (See Paterson, N. J. and Scranton, Pa.)
- New Lebanon.** D-2. L. S. & M. S. RR, Oil City & Hudson Line.
- BRUNER, H. C. Out of business.**
- Newport.** H-10. (Not shown on map.) Pa. RR.
- ROMBERGER, H. A. (Branch Mill);** (K) Ladies' Cotton Hosiery; 40 knitting machines; 14 sewing machines; sell direct. (See also Middletown, Pa.)
- Newville.** J-9. C. V. RR.
- NEWVILLE KNITTING CO.;** \$80,000; W. (K) C. Woodburn, pres; W. C. Brewster, treas; James Thornton, supt.; Men's Half Hose and Ladies' Ribbed Underwear; 176 knitting machines; 26 body frames; steam; dye; L. Neebe, Boston and S. Earnstein, N. Y.; W. C. Woodburn, buyer. (Buy 8 to 24 yarn.)
- Norristown.** J-15. P. RR, Schuylkill Div; P. & R. RR, Norristown Br; Stony Creek RR.
- CORAL MFG. CO.;** Oak & Smith Sts; \$10. (W) 000; Joseph Greer, pres; John Greer, treas; W. E. Montagne, supt; Carpets and Art Squares; 10 broad and 10 narrow looms; steam; dye; sell direct; Wm. E. Montagne, buyer. (Buy 2/14, 2/16 cotton warp and skein, 2 ply Jute yarn 11 lbs.)
- EUREKA KNITTING CO.;** \$50,000; E. S. (K) Adams, pres.; Edwin Metcalf, treas.; Robt. C. Selden, supt.; Cotton Rib Underwear; 39 knitting machines; steam and water; dye; sell direct; E. S. Adams, buyer.
- HIRSCH & LAZARUS.;** Penn Art Square (W) Mill; 351-357 E. Lafayette St; Granite Art Squares; 10 special broad rug looms; steam; dye; sell direct; firm, buyers. (Buy 14/2 cotton, 11/2 jute.)
- IVINS, DIETZ & METZGER CO.;** Norris. (W) town Carpet Mills; Wilton and Brussels Carpets; (buy yarns); 46 looms; steam. (Branch of Phila. mill.)
- KEYSTONE HOSERY CO.;** Oak St; Cotton (K) Seamless Hosiery and Underwear; 300 knitting machines; steam; sell hosiery direct; Critten, CHIT & Co., underwear.
- NORRISTOWN HOSERY CO.;** 100 East (K) Main St; M. D. Yost, buyer; Seamless Hose and Half Hose; 200 knitting machines; steam; sell direct.
- NORRISTOWN WOOLEN CO.;** \$100,000; (W) Geo. F. Coleman, pres; A. P. Hunter, sec. treas. and mgr; Men's Wear Woolens; 4 sets; 49 broad and 1 narrow looms; steam; dye; H. & W. H. Lewis, N. Y. Boston, Phila, Chicago, s. agts; Ashley P. Hunter, buyer.
- RAMBO & REGAR (Inc.);** \$400,000; Jos. S. (K) Rambo, pres.; H. K. Regar, treas.; Cotton and Lisle Hosiery; 450 knitting machines; steam; dye; sell direct.
- SCATCHARD, HENRY F. MFG. CO.;** \$75,000; (W) Wm. H. Brooks, pres; Henry F. Scatchard, treas.; Thos. L. Cowan, supt.; Cotton,

- Woolen and Merino Yarns, Cloths and Shoddies; 4 sets; 27 looms; steam; dye; Morton H. Meinhard & Co., N. Y., s. agts.; H. F. Seatchard, buyer.
- STAR KNITTING MILLS:** Lewis E. (K & D) Tumbel, prop; Cotton and Worsted Seamless Hosiery and Custom Dyeing; 350 knitting machines; steam; dye; Watson, Porter Giles & Co., N. Y., s. agts.; Lewis E. Tumbel, buyer. (Buy yarn, s. to 30s in carded Peeler and carded and combed Egyptian.)
- WATT, WM. & SON;** Hermann Preissler, (W) supt.; Cheviots; 5 48" sets cards; 22 64 Knowles looms; steam; dye; H & W. H. Lewis, Boston, Chicago, Phila., and N. Y., s. agts. Geo. W. Watt, buyer.
- WOODSTOCK MILLS CO.;** \$75,000; Wm. W. Johnston, Pres.; W. A. Flanagan, sec. and treas.; J. Morton Brown, mgr; Union Casimires, Dress Goods and Cloakings; 7 sets; 107 looms; steam; dye; Jacob Wendell & Co, N. Y., s. agts.
- WYOMING MILLS.** *Out of business.*
- North Wales.** H-15. P. & R. RR, Bethlehem Br.
- ACORN WEB WORKS.** THE; A. Coleman, (C) treas; Elastic and Non-Elastic Webs; 32 looms; steam; sell direct; Wm. Schirmer, buyer. (Buy 40/2, 20/2, 20/3, 21/2 and 8/3 yarn.)
- FIBRE SPINNING CO, THE, LTD;** (Phila of (A) fice, 113 Chestnut St.); \$15,000; C. Huber, pres. and treas; Geo. Schafnacker, sec. and mgr.; Asbestos Yarns, Rugs and Table Paddings; steam; sell direct.
- MONTGOMERY MILLS;** (Russell Mfg. Co.); (C) Suspenders and Truss Webbing; 40 looms; steam; sell direct. (See also Middletown, Conn.)
- Oak Grove.** J.I. (Not shown on map.) P. C. C. St. L. RR
- RICH, JOHN & BROS.;** (Woolrich); Knit (K) ting mill. *Proposed.*
- Oak Hall Station.** F.S. Penn. RR.
- OAK HALL WOOLEN MILL;** R. C. Palmer; (W) Yarns, Flannels, Blankets and Skirts; 1 set; 6 looms; water; dye; sell direct.
- Oakland Mills.** G-9. P. RR.
- SPONHAUER, A;** Laurel Run Mill; (W) Blankets, Jeans, Yarns, Etc; 1 set; 4 looms; water.
- Orwigsburg.** G-43. L. V. RR.
- FRANKLIN KNITTING MILLS, THE;** Moyer (K & Heisler; N. H. Moyer, supt. and buyer; Ladies' Knit Cotton Underg. sts, using 38 to 20s cotton yarn; 24 knitting machines; steam; sell direct and L. P. Naylor & Co., and Sutton & Co., N. Y., s. agts. (Formerly at Boyertown, Pa.)
- ORWIGSBURG KNITTING MILLS;** J. A. (K) Sharidan, (successor to Kock & Sharidan); Underwear; 10 knitting machines; L. J. Riggins, N. Y. s. agt.
- Oxford.** K-13. L. O. & S. RR, and Phila. W. & B. RR.
- RUSSELL, WM. C.;** Carpets; 2 hand looms. (W)
- Palmyra.** H-11. P. & R. RR.
- MILLER, R. H. & SON;** Benj. Miller, supt; (K) Cotton and Woolen Ladies', Men's and Children's Seamless Hosiery; 8 knitting machines; sell direct; Benj. Miller, buyer.
- PALMYRA HOSIERY MILL;** S. F. Engle (K and Jno. A. Balsbaugh); Men's Half Hose; 160 needle; 12 knitting machines.
- Parsons.** E-13. D. & H. RR., C. RR. of N. J.
- PARSONS SILK THROWING CO.;** \$40,000; (S) Geo. G. Tillotson, pres.; J. R. Tillotson, treas.; Commission Throwsters; 11,000 spindles.
- Pennsburg.** H-15. P. & R. RR.
- EUREKA RIBBON CO.;** A. S. Schantz, (S) mgr; Broad silks; 50 looms.
- Pennrun.** G-5. Eight miles from Indiana, GREEN, WM. H.; Blankets, Flannels, (W) Yarn, Etc; 1 set; 7 looms; steam; dye.
- Philadelphia.** J-15. See beginning of Pennsylvania.
- Phoenixville.** J-14. A. V. RR, Low Grade Div.
- BYRNE, THOS. F.;** Ladies' Ribbed Under. (K) wear and Seamless Hosiery; 150 knitting machines; steam; bleachery; J. V. DuBois, s. agt; also sell direct. (Buys yarns No. 5 to 20.)
- JOHNSON, COWDIN & CO.;** Sankanae Mills; (S) (Paterson, N. J.) Jacob Salathe, supt. and buyer; Thrown Silk and Silk Ribbons; 14,000 spindles; 97 looms; steam; sell direct, 119 & 121 Spring St., N. Y.
- O'DONNELL, WM. J.;** Ladies' Underwear; (K) 8 knitting machines; 10 sewing machines; electricity; sell direct.
- PARSONS & ANGSTADT;** \$8000; Lewis P. (K) Parsons, supt; Men's Half Hose and Misses' Ribbed Hosiery; 30 knitting machines; steam; finish; John M. Given, s. agt.
- PARSONS & BAKER;** Hall St; \$6000; (K) Ladies' Ribbed Underwear; 11 knitting and 10 sewing machines; steam; sell direct, 1. L. Stern, 906 N. Y. Life Bldg., N. Y. representative; Mr. Parsons, buyer. (Buy 22s and 24s cotton yarn, also some hisle.)
- PERSEVERANCE KNITTING CO., LTD.;** (K) Ambler Davis, pres. and supt; Wm. Rice, treas; Ladies' and Children's Ribbed Underwear; 25 knitting and 15 sewing machines; steam; bleach; sell direct and L. P. Naylor & Co., and C. H. Swearingen, Pittsburg, s. agts; Ambler Davis, buyer. (Buy No. 20 unbleached cones and 12/2 soft skein.)
- WALTERS, E. E.;** Union Knitting Mills; (K) (formerly Walters Bros.); Ribbed Underwear; 12 knitting machines; 10 sewing machines; L. J. Riggins, N. Y., s. agt.
- Pickering.** J-14. Pa. RR.
- MILLS, JAS. & GEO.;** Blankets; 1 set; 6 (W) looms; water; dye; O. H. Hayes & Co, N. Y., s. agts.
- Pittsburg.** H-2. A. V. RR; B. & O. RR; Penn. RR; P. & L. E. RR.
- PITTSBURG WASTE CO.;** 317 Penn. Ave; (W) \$25,000; Joseph S. Brown, pres; Maurice Faulk, sec. and treas; Waste; 3 pickers; 1 willow; 3 waste machines.
- POTTS, O. A. Co.;** \$50,000; 20 McCancee (K) Bldg, 7th Ave.; O. A. Potts, mgr; 84 needle goods. *Proposed.*
- Pittston.** D-13. C. RR. of N. J; D. & H. C. Co, Penn. Div; D. L. & W. RR, Bloomsburg Div; E. & W. V. RR; L. V. RR, North Br. Div, Wyoming Div.
- ALPINE KNITTING CO.;** John Coleman, (K) pres; M. W. O'Boyle, treas; John H. Foy, sec; Ribbed Underwear; steam; dye; Critten, Cliff & Co, 18 Leonard St, N. Y., s. agts. Buy cotton and worsted yarns, 10s to 40 single and 30s to 70s two ply.)
- FRANKLIN MILLS;** \$5,000; Edward Rat. (C) ledge, pres. and mgr.; W. H. Rutledge, sec. and treas; Cotton Tapes, Braids and Bindings; 50 looms; 225 braiders; steam.
- FROST & VAX RIPER;** Throwsters; 12,000 (S) spindles; steam. (Also Paterson, N. J.)
- LEZNERE KNITTING MILL;** E. L. Ehl. (K) Thorpe; Men's, Ladies' and Children's Flat Underwear; 4 sets; 24 cylinders; steam; dye; sell direct; N. Y. office, 76 Leonard St.
- VALENTINE & BENTLEY SILK CO.;** Dress (S) Silks, Ribbons, etc; 8,000 spindles; 100 looms; steam. (Also Newton, N. J., and Watertown, N. Y.)
- Pleasant Mount.** C-14. N. Y. & O. W. RR, Scranton Div.

- WINNER, K. P.; Flannels and Yarns; 1 (W) set; 3 looms; steam and water; dye; sell direct.
- Plymouth.** E-13. D. L. & W. RR, Bloomsburg Div.
- ATWOOD M. J.; Lewis Atwood, supt; (S) Thrown Silks; 10,000 spindles; steam.
- SHAWNEE KNITTING MILLS; Templeton (K) Bros; Seamless Half Hose; 29 knitting machines; Nathan, McDavitt & Billings, s. agts; capacity 100 doz. per day.
- WEST, A.; Pioneer Knitting Mills; Cot. (K) ton, Worsted and Fancy Silk Half Hose; 500 knitting machines; steam; dye; Stokes, Cromie & Co, Phila, s. agts. (Also Ashley.) (Buy 11 up to 50/1 skein and cones.)
- WEST, THOS; Wyoming Valley Knitting (K) Mills; Half Hose; 200 knitting machines; steam; dye; Chaffee, Moorehouse & Co, 45 Worth St, N. Y., and H. J. Farber, Drewry & Co., Balto, s. agts. See also Danville and Nanticoke.
- Port Carbon.** G-13. P. & R. RR.; S. RR.
- HEEBNER, GEO. W. & SON; Ladies' (K) Knit Underwear; 6 knitting machines; steam; R. Lamson & Co., N. Y., s. agts. (Buy High Grade Peeler and Bleached Yarns, Nos. 208, 218 and 228.)
- Pottstown.** H-14. P. RR, Schuylkill Div; P. & R. RR, Colebrook Br.
- CHAMPION SILK CO; C. E. Gudebrod, pres; (S) P. F. Gudebrod, treas. and supt; Sewing and Spool Silk, Trans, Organzine, Floss, etc; steam; dye.
- FRITZ & KRAUSE; (Inc); John Hushen, (K) supt; Cotton and Lisle Hosiery; 143 knitting machines; steam; sell direct and E. M. Farber & Co, s. agts; firm, buyers. (Buy yarns, 8 to 60s.)
- PARK HOSIERY CO.; (INC.); Removed to Reading, Pa. See Reading Hosiery Co.
- POTTSTOWN KNITTING CO; York and (K) Walnut Sts; \$15,000; Thos. Searles, pres; J. Clemons, sec.; H. M. Browne, treas; Ladies' Hosiery and Men's Half Hose; 76 knitting machines; steam; sell direct and Bacon & Co., s. agts; J. Clemons, buyer.
- Pottsville.** G-12. Peoples Ry; L. V. RR, Tomhicken & Pottsville Br; Schuylkill & L. V. RR; P. RR, Minersville Br, Schuylkill Div, Sumbury Div; P. & R. RR, Frackville Br, Mt. Carbon Br.
- ADCOCK, J. C. BROS. & CO; Cotton Half (K) Hose; 56 knitting machines; steam; dye; A. A. Smith, N. Y. Life Bldg., N. Y. s. agt. J. C. Adcock, buyer.
- AIKMAN, JAS. J.; Hosiery; 20 knitting (K) machines.
- BOLTZ, W. K.; (formerly Boltz & Saus. (K) ser); Ribbed Underwear; 10 knitting machines; 14 sewing machines.
- GINTHER BROS; Ladies' Summer Vests; (K) 3 knitting machines; L. J. Riggins, s. agt.
- KOPP, J. J.; Carpet Weaver. (W)
- LEIB & MILLER; Velvets. (S)
- PENN TEXTILE MFG. CO.; \$15,000; (S D & B) E. S. Haeseler, pres.; Chas. T. Bowen, treas.; B. J. Smith, sec.; B. W. Wilkins, agt.; F. Stubbs, supt. and buyer; Seal Plush, Velvet and all Pile Fabrics; 32 looms; steam; dye and bleach; Spielman & Co., s. agts. (Also Hosiery and Underwear and Cotton in Skeins or Warps); capacity 10,000 lbs. per day. (In plant formerly known as Schuylkill Plush and Silk Co.) (Buy 2/20, 2/16, 2/30, 1/16, 2/24, 2/100, 2/12 1/2 yarns.)
- REBER, JOHN; 14th and West Market Sts; (K) Harry D. Boulter, supt.; Cotton Hosiery; 106 knitting machines; steam; dye; sell direct; John Heber, buyer.
- SCHUYLKILL CO. PRISON; E. K. (W & K) Barla, warden; Michael Schoneman, supt; Carpets and Hosiery; 7 knitting machines;
- L. J. Riggins, s. agt. (Buy hosiery yarns, No. 68 to 88 and carpet warps, 4/4, 4/8, 3/8.)
- TILT SILK MILL; J. M. Harris, mgr; (S) Throwing and Ribbons; 48,000 spindles; 75 looms; steam. (See also Phoenix Silk Mfg. Co, Paterson, N. J., and Allentown, Pa.)
- UNGER, SAMUEL; West End Knitting (K) Mill; (formerly Unger & Leininger); Ladies', Misses' and Children's Patented, Union Suits; 13 knitting machines; steam; E. M. Townsend & Co., N. Y. s. agts.
- Quakertown.** G-15 Phila. & Read. RR; Quakertown & Eastern RR.
- QUAKERTOWN SILK CO.; \$10,000; W. Little. (S) pres; H. B. Vaughn; sec. and treas.; Jas. Scott, supt.; Broad Silks; 62 looms; steam; Scheffer, Schraumm & Vogel, N. Y., s. agts.
- Reading.** H-13. R. & S. RR (electric), W. & N. P. RR, Schuylkill Div; P. & R. RR, E. Penn. Br, Lebanon Valley Br, Schuylkill & Lehigh Br.
- ACTIVE KNITTING MILLS; E. R. Wood, (K) prop; 222 Chestnut St; Ladies' Seamless Hosiery; 24 knitting machines; steam. (Buy 16s cotton mule spun yarns.)
- AMERICAN NARROW FABRIC CO.; E. D. (C) Trexler, Chas. K. Dorr and John M. Frame; Narrow Ribbons, Braids and Fabrics. Proposed.
- AMMON, E. S.; 17 S. Front St; Ladies' and (K) Children's Cotton Knit Underwear; 18 knitting machines; steam; sell direct; E. S. Ammon, buyer. (Buy cotton yarns, No. 10 to 22, on cones.)
- BLACK DIAMOND HOSIERY MILL; (N. E. (K) cor. Front and Washington Sts.); Geo. M. Gantz, treas.; Thos. W. Tustin, supt.; Ladies' Hose and H-f Hose, all Lisle and Lace Work, 180 to 200 needles.
- BOBST, W. J.; Cotton Hosiery; 175 (K) knitting machines; (buy 5s to 15s yarn); steam; M. H. Farber, Balto; Condit & Arnold, Indianapolis, and F. M. Farber & Co, N. Y., s. agts; W. J. Bobst, buyer. (Buy 5 to 15, both colored, white and mixed yarns.)
- BOYER, THOS. A.; 523 Bingham St; Rag (W) Carpets; 2 looms; (buys 4/4 cotton yarns, also linen and wool); hand power; sell direct.
- BRUMBACH, A. J; St. Lawrence Mill; (W) Sol A. Brumbach, supt; Cassimeres; (buy 16-20-2 yarn); 3 sets; 39 looms; steam and water; dye.
- BRUMBACH BROS; Exeter Mills; Wool. (W) en Cassimeres; 2 sets; 21 looms; steam; dye; sell direct; firm, buyers. (Buy 16/2 and 20/2 cotton yarns.)
- CROWN KNITTING CO, THE; Dr. W. D. De (K) Long, pres.; Dr. J. K. Seaman, treas.; Men's Half Hose; M. H. Mishler, buyer.
- EAST PENN HOSIERY CO; 8th and Spring (K) Sts; \$50,000; Adam B. Rieser, pres; O. B. Wetherhold, sec. and treas.; Men's Seamless Half Hose; 142 knitting machines; steam; Bateson & Dowd, N. Y., s. agts.; O. B. Wetherhold, buyer. (Buy carded Peeler, 15s to 24s; Combed Egyptians, 18s to 24s and Combed Peeler, 2 ply.)
- EPLER, H. R. & SON; Men's Half Hose; 9 (K) knitting machines; steam; 80n, buyer.
- GARNER & Co; Reading Cotton Mill; (C) South 9th St; Wm. E. Thom, pres. and treas; Ellis L. Castor, supt; Shirtings and Dress Goods; 17,216 spindles; 412 looms; steam; N. Y. office, 2-16 Worth St; Ellis L. Castor, buyer.
- GEIGER & GROFF; Gem Knitting Mills; (K) (formerly Achilles Knitting Mills); 17 So. Front St; Fine Cotton Half Hose; 51 knitting machines; steam; sell direct; firm, buyers. Buy 8s, 11s, 14s and 40s white cotton yarn.)

- GREBE, GEO. H. & CO; *Out of business.*
- GRIMSHAW BROS. Eleventh and Marion (S Sts.; (also Paterson, N. J.); Throwing and Broad Silks; 10,000 spindles; 135 looms; steam.
- GUENTHER, GEO. G.; 752 Penn and 751 (K Cherry St; Chas. T. Sullivan, supt; Half Hose; Children's Ribbed and Ladies' Hosiery; 128 knitting machines; steam and water; sell direct; Geo. G. Guenther, buyer. (Buy 9s to 60s white yarn.)
- HAMPDEN KNITTING MILLS CO.; 552 No. (K 11th St; \$50,000; F. W. Hamold, pres; Theodore Troup, treas.; John Knapp, supt.; Fine Seamless Hosiery; 50 knitting machines; steam; sell through agents. (Buy Carded, Peeler and Combed Egyptians.)
- HAWK, KNITTING CO.; (formerly Geo. W. (K Hawk); 2d and Buttonwood Sts; \$50,000; Geo. W. Hawk, pres. and supt.; Wm. H. Kehel, treas.; Seamless Half Hose; 150 knitting machines; 7 sewing machines; steam; dye; sell direct. (Buy yarns, 8s to 80s.)
- HENDEL, GEO. & SONS; Wool Hats; (W 6 sets; steam and water; dye; C. H. Tenney & Co, N. Y., s. agts.
- HENDEL HAT CO; Wool Hats; 6 sets; (W steam; dye; C. H. Tenney & Co. and G. t. thold & Co., N. Y., s. agts.; John R. Hendel, buyer.
- HENDEL WM. B.; 752 Penn St; Fine (K Cotton Hosiery; 59 knitting machines; 11 ribbers; 8 loopers; electric; sell direct; (Buy various numbers yarn.)
- JACKSON, THOS. & SON; Reading Cordage (J Wks; Manila, Sisal and Jute Rope, Cordage and Twine; Peter N. Crichton, supt.; 300 spindles; steam; sell direct; Henry H. Jackson, buyer.
- KAUFFMAN, JAS. K.; Thorn and Walnut (K Sts.; Cotton Hosiery; (14 needle); 20 knitting machines; 4 ribbers; 2 loopers; steam; sell through agents.
- KESSLER, C. F. & SONS; 11th and Spruce (W Sts; Wool Hats; 5 sets; steam; dye; C. H. Tenney & Co, N. Y., s. agts.
- KEYSTONE KNITTING MILLS; Levi B. (K Paxton, Jr, prop; Cotton Half Hose; 15 knitting machines; (buy 13s, 14s and 40s yarn), sell direct.
- KNOLL & ALTHOUSE; Never (D, B1 & P Franklin Dye Works; 925-929 Muhlenberg St; N. S. Althouse, supt.; All Kinds Dyeing, Fast Black, Bleaching, Printing and Extracting a Specialty on Hosiery; steam.
- KRAEMER, LOUIS, & CO.; Stony Creek (W Mills; Louis F. Grebe, supt.; Cassimeres and Cloaking; 3 sets; 25 looms; steam; dye; sell direct; Louis F. Grebe, buyer. (Buy 16/2 cotton warps.)
- KUEISTEN & RICK; cor. Reed & Elm Sts; (K Men's, Ladies' and Childrens' Fine Seamless Hosiery; 150 knitting machines; sell direct; 76 Franklin St; N. Y. (Buy 11s to 40s white yarn.)
- LANDO, WM. H.; Thorn and Walnut Sts; (K Variety of Fine Hosiery; 15 knitting machines; steam; sell direct. (Buys No. 10 to 40 white yarns.)
- LEINBACH, J. G. & CO; Reading Woolen (W Mill; 337 No. 4th St; Cassimeres, Etc; 3 sets; 40 looms; steam; dye; sell direct; J. G. Leinbach, buyer. (Buy 16/2 cotton warp.)
- LIBERTY DYE WORKS; Eli Schluze (D & P & Son; Chestnut and Millin sts.; Dyers of Cotton Hosiery and Yarns; steam; (also print).
- LOOSE, JAMES K.; Walnut and Thorn Sts; (K Knit Underwear; 15 knitting machines.
- MILLER, JOHN R. & CO; Henry R. Miller, (W supt; Men's, Boys' and Ladies' Wool Hats; 5 sets; steam; dye; sell direct and C. H. Tenney & Co., N. Y., s. agts.
- MILLER, S. S.; Walnut and Thorn Sts.; (K Cotton Half Hose; 25 knitting machines; sell direct; S. S. Miller, buyer. (Buy yarn, 20s to 4s.)
- MOHN, J. G. & BROS; 213 South 11th St; (W Wool Hats; 8 sets; steam; dye; C. H. Tenney & Co, Wm. Carroll & Co, N. Y., s. agts.
- NARROW FABRIC CO; 946 Court St; \$20. (C & S 000; F. W. Korth, mgr.; Narrow Fabrics, Braids, Cotton and Silk; steam; F. W. Korth, buyer. (Buy 16/2, 20/2, 26/2, 40/2 medium warp twist. 40/2, 50/2, 60/2 mercerized yarn.)
- NOLDE & HORST CO; 820 Moss St; \$250,000; (K Jacob Nolde, pres; Geo. D. Horst, treas; John D. Horst, supt.; Cotton Hosiery; 500 knitting machines; steam; dye; sell direct and Bateson & Dowd, 78 Franklin St., N. Y., s. agts.; Geo. D. Horst, buyer. (Buy 24/2 to 44/2 combed Egyptian lisle on cones and skeins.)
- PARKER, RICHARD H.; Cotton Half Hose (K and Misses' Hosiery. *Burned.*
- PENNSYLVANIA KNITTING MILLS; 8th St; (K \$50,000; Otto C. Heinze, pres; Max H. Schult, treas.; Theo P. Spitz, mgr; Cotton Hosiery, Men's and Ladies; 500 knitting machines; steam; dye; sell direct; N. Y. office, 81 Franklin St.
- PROSPECT DYE WORKS; 120-132 Moss (D St.; \$25,000; Otto Reissmann, pres.; Max Thus, treas.; Hosiery and Yarn, Etc.; steam; sell direct; pres. and treas., buyers.
- READING BRAID CO; 239 & 241 Cedar (W & S St.; \$25,000; F. S. Livingood, pres; Geo. A. Wanner, treas.; C. M. Steumetz, sec. and gen'l mgr; Fred W. Klein, supt; Worsted, Mohair, Cotton and Silk Braid and Trimmings; 500 braiders; steam; sell direct; mgr. and supt. buyers; N. Y. office, 438 Broadway; Phila. office, 839 Market St.
- READING CARPET MFG. CO. *Out of business.*
- READING GLOVE & MITTEN MFG. CO; (K \$50,000; Ferd. Goetz, pres; Jno. H. Maltzberger, sec. and treas; Fabric Gloves and Mitts, Lace Gloves, Military Gloves, Fleece, and Golf Gloves; 11 looms; steam; Wesendonck, Lorenz & Co., N. Y., s. agts.; (Buy yarns, lisle, cotton and worsted.)
- READING INDUSTRIAL WORKS CO. (Inc.); (C 141-143 Cedar St; \$50,000; E. Thalheimer, pres; M. H. Seidel, treas and supt; Handkerchiefs, and Swiss Embroideries; 4 embroidery machines; steam; sell direct.
- READING KNITTING MILLS; Gaenzle & (K Leippe; 4th and Elm Sts; 84 needle Half Hose; 200 knitting machines; steam; sell direct and S. S. Carpenter, N. Y., N. E. Peters, San Francisco, J. F. Durbin, Balto., Joseph Seltzer, Cinn., E. Seltzer, Chicago, s. agts.; Chas. E. Leippe, buyer. (Buy 6s, 8s and 10s white and 6s to 12s mixed yarns.)
- READING HOSEY CO.; \$50,000; Geo. G. (K Runyon, pres.; H. C. Geissler, treas.; Arthur Booth, supt.; Ladies' Hosiery and Half Hose (use yarns 10s to 50s); 300 knitting machines; steam; Dresser & Co., s. agts.; Arthur Booth, buyer. (Removed plant from Pottstown.)
- READING UNDERWEAR CO.; Front and (K Washington Sts.; Ladies' Light Weight Underwear.
- SCHILHOFF BROS.; 243 S. 10th St.; Wool (W Hats.
- SHANTZ, H. C.; 111 Lemon St; Hosiery; (K 40 machines.
- SKINNER & KADES (formerly E. Kades); (K 415 Moss St.; 84 and 160 Needle Half Hose; 46 knitting machines; steam; sell direct; I. Kades, buyer.
- SMITH, C. J.; 329 No. 8th St; Rag Car. (W Pets and Rugs; 3 looms; (buy 4 ply yarn); sell direct.

- STORK KNITTING MILLS, THE;** Men's (**K**) Medium Half Hose; 16 knitting machines; 3 ribbers; steam; sell direct; firm buyers.
- SWARTZ, B. F.;** 222 Pearl St.; 36 Gauge, 14- (**K**) Needle Half Hose; steam; sell direct. (Buy 10 and 11 cotton yarn.)
- WEBER, ALBERT;** Hosiery; 200 knitting (**K**) machines; steam; J. Van Wyck Du Bois, N. Y., s. agt.
- WEBER & CO.;** 126-132 Orange St.; Hos- (**K**) iery; 300 knitting machines; steam; J. Van Wyck Du Bois, 43 Leonard St., N. Y., s. agt.
- Reedsville.** G-9. P. & R. RR.; P. RR.; Millin & Centre County RR.
- GIBBONEY, A. R. & CO.;** Blankets, Flan- (**W**) nels and Yarns; 1 set; 5 looms; steam and water; dye; sell direct; A. R. Gibboney, buyer.
- Reinholds.** H-13. Phila. & Reading RR.
- WYOMISSING HOSIERY CO.;** (P. O. (**K**) address Mohm's Store); A. S. Hornberger, supt.; 84 needle Full Seamless Mixed Half Hose; 24 knitting machines; 48 cylinders; steam. (Branch of Mill at Mohm's Store.)
- Renovo.** E-S. Penn. RR.
- COMBY SILK MILLS;** H. Walder; Broad (**S**) Silks; 100 looms; steam. (Also West Hoboken.)
- Reynoldsville.** E-4. A. V. RR, Low Grade Div.; R. & E. C. RR.
- ENTERPRISE SILK CO.;** (successors to (**S**) American Silk Co.); Satins, Taffetas, Etc; 200 looms; steam; sell direct. (Also Paterson, N. J.)
- REYNOLDSVILLE WOOLEN CO.;** (**W** & **K**) (Inc.); \$50,000; S. B. Elliott, pres.; John H. Kaucher, treas.; L. W. Huyck, supt.; Hos- iery, Shirts and Pantalooms; 2 sets; 22 looms; 16 knitting machines; steam; dye; sell direct and Jas. Freeman Brown Co., s. agts.; L. W. Huyck and Executive Com- mittee, buyers.
- SYKES, G. W., & SON;** Meltons; 1 set; 6 (**W**) broad looms; steam; dye; sell direct.
- Riegelsville.** G-15. P. R. RR.
- Clymer, LEE S.;** Durham Knitting Mills; (**K**) James Maryville, supt.; Ladies' and Chil- dren's Underwear; 13 knitting and 30 sewing machines; gasoline; bleach; sell direct; Lee S. Clymer, buyer. (Buy 10s to 20s Common Peeler, Silver Gray and Egyptian yarn.)
- Ringtown.** F-12. P. & R. RR.
- RINGTOWN KNITTING CO.;** R. R. Brusch, (**K**) pres.; H. D. Rentschler, treas.; A. Wm. Sheely, supt.; Men's Fine Half Hose; 176 needle; 20 knitting machines; 4 loopers; 4 ribbers; steam.
- Robesonia.** H-13. Phila. & R. RR.
- LEINBACH & HIGH;** Robesonia Knitting (**K**) Mills; Seamless Half Hose; 40 knitting machines; steam; salesrooms 43 Leonard St., N. Y.
- Roseberg.** H-10. (Not shown on map) RR. station Newport, Pa. RR.
- McLAUGHLIN, JAS. C.;** Woolens; 1 set; (**W**) 2 looms; water; dye.
- Rosenick.** J-13. P. R. RR.; Pomeroy & Newark RR.
- OGDEN'S, JAMES, SONS;** Woolen Yarns; 1 (**W**) set; 432 spindles; water. *Not running.*
- Royer's Ford.** H-14. P. RR, Schuylkill Div.; P. & R. RR.
- EMMERS, E. & CO.;** American Shirt & (**K**) Hosiery Co.; Ladies' Jersey Ribbed Vests and Seamless Hosiery in Cotton; 200 knit- ting and 150 sewing machines; steam; finish; sell direct.
- ROYER'S FORD DYE WORKS;** Frank (**D** & **BI**) Kupka; Dyeing Hosiery and Bleaching Underwear; steam.
- Sandy Lake.** D-2. L. S. & M. S. RR, Oil City & Andover Line.
- SCHAEFFER, J. M.;** Sandy Lake Woolen (**W**) Mills; Blankets, Flannel and Yarn; 1 set; 234 spindles; 1 loom; steam; dye; sell direct.
- Schuylkill Haven.** G-13. L. V. RR.; Schuylkill & L. V. RR.; P. & R. RR, Mine Hill & Schuylkill Haven Br.; P. RR, Schuylkill Div.
- BAKER, BROS.;** Star Knitting Mill; Cot- (**K**) ton Knit Underwear; 20 knitting ma- chines; 23 finishing machines; steam; E. M. Townsend & Co., s. agts. (Buy yarns No. 10, 11, 12, 20 and 22, in white and silver gray.)
- BAST, J. F.;** Royal Knitting Mill; Fancy (**K**) Jersey Underwear; 19 knitting machines; sell direct and C. H. Swearingen, s. agt.
- BERGER, H. & SONS.;** Spring Garden (**K**) Underwear Mill; John D. Berger, supt.; Cotton Underwear; 33 knitting machines; 45 finishing machines; steam; Critten, Clift & Co., s. agts.; firm, buyers. (Buy mostly 6, 11, 21 and 24 yarn.)
- DEBERT, E. K.;** *Out of business.*
- HOFFMAN & DOHNER.;** Ladies' Cotton (**K**) Ribbed Underwear, extra sizes; 7 knit- ting machines; steam; L. P. Naylor & Co. and Roger Lamson & Co., s. agts.; R. J. Hoffman, buyer. (Buy No. 22 cones.)
- KLINE, ALBERT II.;** Standard Knitting (**K**) Mill; Cotton Underwear; 16 knitting, 22 sewing machines; steam; sell direct.
- LAUTENBACHER, A.;** Enterprise Knitting (**K**) Mills; Ladies' Fancy Ribbed Underwear; 28 knitting and 56 finishing machines; steam; Roger Lamson & Co., N. Y., s. agts.; J. C. Lautenbacher, buyer.
- MECK & COLDREN.;** Ladies' and Men's (**K**) Underwear; 9 knitting machines; 25 fin- ishing machines; steam; sell direct; Walter S. Meck, buyer. (Buy mostly Peeler yarns, 8s to 22s.)
- REED & LEININGER.;** Ribbed Vests; (**K**) 7 knitting machines; steam; bleach; Al- bert Spooner, s. agt.
- MACK, J. S. & CO.;** Silk Throwsters; 50,000 (**S**) spindles; steam. (See also All town.)
- ROWLAND, SAMUEL.;** Bleachery (**BI** & **D**) and Dye Works; Specialty, Cotton Knit Goods; steam.
- SCHUMACHER, KELLER & CO, LTD.;** En- (**K**) reka Knitting Mill; C. F. Schumacher, pres.; P. C. Detweiler, treas.; Chas. Keller, agt.; Wm. E. Keller, supt.; Ladies' and Misses' Vests, Summer and Winter Weights; 17 knitting machines; 4 sleep- ers; steam; E. M. Townsend & Co.; L. P. Naylor & Co. and F. M. Farber, s. agts.
- SHARDIN, DAN'L.;** Eagle Knitting Mills; (**K**) Jersey Underwear; 31 knitting machines; 25 sewing machines; steam; finish; sell direct and L. P. Naylor & Co., N. Y., and M. H. Farber, Balto., s. agts.
- SMITH & BECH.;** Babies' Sacques. (**K**)
- STANTON, J. E.;** Champion Knitting Mill; (**K**) Ribbed Underwear; 14 knitting machines; 16 sewing machines; W. H. Burgess & Co., s. agts.
- THOMAS KNITTING MILLS, S.;** E. L. (**K**) Thomas, mgr; Men's, Ladies' and Chil- dren's Cotton Underwear; 30 knitting ma- chines; 35 finishing machines; steam; Robertson & Bruhn, s. agts.; E. L. Thomas, buyer. (Buy 6-24s earled and combed yarns.)
- Scranton.** D-14. C of N. J. RR; E. & W. V RR; N. Y. O & W. RR, Scranton Div.; D. & H. C. Co, Penn. Div.; D. L. & W. RR, Bloomsburg Div.
- BLISS, VALENTINE.;** Silk Throwing; 58,600 (**S**) spindles; steam. (Mills also at East Stroudsburg and Dickson, Pa.)

- HARVEY SILK CO., ALFRED;** (Box 123); (S) Tram, Organzine, Fringe, Crepe de Chine, Silk Yarns; 15,000 spindles; steam. (Also Forest City.)
- KLOTS THROWING CO;** \$500,000; Branch (S) Mill; 5,400 spindles; steam. (Also Carbondale, Pa., Cumberland, Md., and Fredericksburg, Va.) (N. Y. office, 487 B'way.)
- LACKAWANNA MILLS;** \$500,000; Wm. Con- (K) nell, pres.; Chas. R. Connell, sec. and treas.; E. G. Conner, supt.; Men's, Ladies' and Children's Woolen and Cotton Underwear; 9 sets; 90 knitting machines; steam; dye; A. S. Baight & Co., N. Y., s. agts.; Chas. R. Connell, buyer. (Buy 9 1/2 cotton cops.)
- MACK, J. S., & Co.;** Silk Throwing; 50,000 (S) spindles; steam. (See also Allentown.)
- REILING, DAVID & SCHOEN;** Broad Silks; (S) 350 looms; steam; sell direct, 453 Broome St., N. Y. See also *Dunmore, Pa., West Hoboken, N. J., and Valley Falls, R. I.*
- SAUQUOIT SILK MFG. CO;** (Phila. and (S) Bethlehem.) Alex D. Stelle, pres.; Richard Rossmoesler, treas.; W. H. Davis, supt.; Thrown Silk, Broad Silks, Dress Goods; 63,000 spindles; 405 looms; steam.
- SCRANTON LACE CURTAIN CO;** \$160,000; (C) J. Benj. Dimmick, pres.; P. B. Berlin, treas., supt. and buyer; Lace Curtains, Nottingham; 15 looms; steam; dye; Creighton & Burch, N. Y., s. agts. (Buy various numbers yarn.)
- SIMPSON, JAMES & Co;** Broad Silks; 10, (S) 000 spindles; 110 looms. See *Paterson, N. J., and New Hope, Pa.*
- Shamokin.** F-11. L. V. RR, Mahanoy Div.; N. C. RR, Shamokin Div.; P. & R. RR, Mahanoy, Shamokin & Herndon Br.; Shamokin, Tumbury and Lewisburg Br.
- FORRY, I. W. & SON;** Seamless Hose and (K) Half Hose; 140 knitting machines; steam; Wm. F. Forry, buyer. (Buy 6 to 15s mixtures, 3s to 4s waste yarn, 6 to 20 frame, 20 to 60 combed yarn. (Also Duaneannon.)
- KLINE, N. R.** *Out of business.*
- SHAMOKIN SILK MILLS;** \$150,000; Jno. H. (S) Eagle, pres.; Alfred Ruegg, treas. and supt.; Dress Goods, Linings and Piece Dyed Goods; 300 looms; steam; S. Peters & Co., N. Y., s. agts.; Alfred Ruegg, buyer.
- SHAMOKIN SILK THROWING CO;** \$15,000; (S) John Mullen, treas.; Commission Throwsters.
- SHAMOKIN UNDERWEAR MILLS;** F. E. (K) Ammerman, supt.; Ladies' Fine Ribbed Underwear; 9 knitting machines; 7 sewing machines; finish; electricity; sell direct and E. J. Chaffee & Co., N. Y., and J. D. Cunningham, Phila., s. agts.
- SHAMOKIN VALLEY KNITTING MILLS;** (K) Ressler & Co; S. L. Ressler, supt.; Men's Half Hose, 160 needle gauge; 60 knitting machines; 6 loopers; 12 ribbers; steam; sell direct; S. L. Ressler and S. B. Hertzig, buyers.
- SPINDLER, E. O.;** Fine Seamless Hosiery; (K) 60 knitting machines.
- TAUBEL, W. F.;** Cheaper Grades of Hosiery; (K) (Branch mill). (See also Riverside, N. J.)
- Sherman.** B-14. (RR, Station, Sarruca.) D. & H. RR; Erie RR.
- STIRK, JOHN;** Flannels, Yarns; 1 set; 1 (W) broad and 1 narrow loom; steam and water; dye; sell direct. *Closed indefinitely*
- Shickshinny.** E-12. D. L. & W. RR.
- SHICKSHINNY WORSTED MILLS;** Fred S. (W) Feather, supt.; Mohair, Alpaca and Worsted Genapped Yarns and Braid Yarns, (Bradford System); 2500 worsted spindles; steam; sell direct. (Also do Commission Spinning. (Buy tops sometimes.)
- Shippensburg.** J-9. C. V. RR; W. M. RR; Balto. & O. V. RR; P. & R. RR, Harrisburg & Pittsburg Line.
- HINKLE, C. K. & SON;** Rag and Jute Car- (W) pets; 3 looms; dye; sell direct.
- SHIPPENSBURG KNITTING CO.;** Frank E. (K) Hollar, sec. and treas.; Real Lace Effect, Silk stitch, Seamless Half Hose; 176 needle; (400 doz. per day); sell direct.
- Shoemakersville.** G-13. (Berks County.) P. & R. RR; P. RR, Schuylkill Div.
- CRYSTAL SPRING DYE & BLEACH (D & B) Works;** office at Hamburg; D. W. Rubright, treas.; Wm. H. Grim, sec.; Bleaching and Dyeing.
- GREBE, GEO. H. & Co.** See *Reading, Pa.* (K)
- WAGNER & HECKMAN;** Men's Half and (K) Misses' Ribbed and Ladies' Hosiery; 53 knitting machines; steam; sell direct. (Buy 8s, 10s, 12s and 16s on cones.)
- WOLFE, WM. & SON;** Globe Knitting (K) Mills; Misses' and Ladies' Ribbed Underwear; 32 knitting machines; steam; dye; sell direct; Room 3, 99 Franklin St., N. Y.; D. S. Wolfe, buyer.
- Slatington.** F-14. P. P. & B. RR; C. RR; P. & R. RR, Schuylkill and Lehigh Br.; L. V. RR, Lehigh Div.; C. RR.
- CRYSTAL KNITTING MILLS;** H. A. Musch- (K) litz, and Wm. Muschlitz; props; Henry A. Muschlitz, supt.; Men's Half Hose; 42 knitting machines; steam; sell direct; H. A. Muschlitz, buyer. (Buy 12, 14, 16 and 40 combed and carded yarns.)
- SLATINGTON KNITTING CO. (LTD.);** (K) Thomas Zellner, pres.; F. A. Kreitz, treas. and supt.; Cotton Half Hose, and Misses and Boy's Ribbed Hosiery; 65 knitting machines; 25 ribbers; 10 loopers; steam; sell direct; F. A. Kreitz, buyer. (Buy cotton yarns on cones, white 8, 10, 12, 14, 16, 20, 40, colored 6, 8, 10, 12.)
- SLATINGTON TEXTILE MFG. CO.;** \$100,000; (S) S. F. Fleisher, pres.; John Niday, treas.; E. C. Loester, agt.; J. P. Shorroek, supt. and buyer; Dress Goods and Cotton Linen Silk; 400 looms; steam; Wm. Iselin & Co., s. agts. (Buy different numbers Schappe Linen yarns.)
- Slippery Rock.** E-2. P. S. & L. E. RR.
- CURRY, WM.;** Cassimeres, Yarns, and (W) Flannels; 2 sets; 5 looms; water; dye; sell direct.
- Smithville.** J-12. L. & R. RR.
- ROYER, C. & SON.** *Out of business.*
- Somerset.** J-5. B. & O. RR; Somerset & Cambria RR.
- KANTNER, S. H. & Co.;** Hosiery Knitting (W) Yarns, Flannels and Carpet; 1 set; 2 looms; steam and water; dye; sell direct. (Buy 3, 4 and 5 ply colored cotton carpet yarn and cotton split warp filling.)
- Souderton.** H-15. P. & R. RR, Bethlehem Br.
- BERGEE, M. B. & Co.;** 84 & 108 needle (K) Ladies' Cotton and Half Hose; 75 knitting machines; steam; sell direct and Jno. S. Tapscott, Baltimore & N. Y., s. agt. (Also branch at Coopersburg, Penn.)
- So. Allentown.** See *Allentown.*
- So. Bethlehem.** G-15. C. RR, of N. J.; L. Y. RR, Lehigh Div.; P. & R. RR, Bethlehem Br.
- DOBBS, GEORGE D.;** Excelsior Knitting (K) Mill; 219 So. Broadway; Misses' Ribbed Hosiery; 125 knitting machines; 105 ribbers; 50 loopers; steam; dye; Wesendonck, Lorenz & Co., s. agts.; G. D. Dobbs, buyer. Buys 1 H. C. P. cones, 1 1/2, 1 3/4, 2 1/2.
- DUPLAN SILK CO.;** \$300,000; (Inc. Feb. '98); (S) (Branch of Duplan & Co., Lyons, France); Jean L. Duplan, pres.; H. Schuakenberg,

- treas; E. J. Lipps, supt. and buyer; Piece dyed, Plain and Novelties; 400 looms; steam; Cozzens, Elbers & Frankard, N. Y., s. agts. (Buy 20/1, 25/1, 30/1, 36/1 carded, combed Egyptian and combed and bleached Peeler.)
- GOULD, C. & J.; So. Bethlehem Hosiery (**K** Mill; Misses' Fine Ribbed Hose and Men's Fine Cotton and Cashmere Half Hose; 100 knitting machines; E. M. Townsend & Co., N. Y., s. agts. (Also Phila.)
- GRUBE, GEO W.; 144 Spring St; Silk Kdb (**S** boms; 12 looms. (Moved to West Bethlehem.)
- HALCYON KNITTING MILLS; Wm. H. Ja. (**K** cobs, prop; Cotton Half Hose; 90 knitting machines; 20 loopers; 24 ribbers; 2 sewing machines; steam; Stokes, Cromie & Co., s. agts.
- LEHIGH STEAM BLEACHERY; W. H. (**B** Gosner, prop; 320-322-324 New St; Bleached Ladies' Underwear direct from the knitter, before cut into garments.
- LEHIGH VALLEY SILK MILLS; \$225,000; E. (**S** J. Lipps, pres. and supt; W. A. Wilbur, treas.; Piece Goods, Broad and Fancy Silks, Novelties; 27,000 spindles; 850 looms; steam; Cozzens, Elbers & Frankard, s. agts.; E. J. Lipps, buyer.
- So. Williamsport.** E-10. (Part of Williamsport.)
- BAILEY, G. W.; Cotton and Wool Hose; (**K** 6 knitting machines; 2 loopers; 1 ribber; sell direct to retail trade.
- Spartansburg.** C-3. W. N. Y. & P. RR.
- EDWARDS WOOLEN CO; \$25,000; J. P. (**W** Edwards, pres. and supt; Wm. Edwards, Jr, treas; Blankets, Flannels, Yarns, etc; 1 set; 360 woolen spindles; 5 broad and 3 narrow looms; steam; dye; sell direct; W. Edwards, Jr, buyer.
- TAUBER WOOLEN MILLS, THE; J. C. (**W** & **K** Tauber, pres.; C. H. Tauber, treas.; E. L. Tauber, supt.; Hosiery, Wool Comforts, Skirts, Flannels, Yarns; 2 sets; 4 looms; 16 knitting machines; steam and water; dye; sell direct; C. H. Tauber, buyer.
- Spring City.** H-14. P. RR, Schuylkill Div. See also *Royersford*.
- CENTURY KNITTING CO.; Abraham D. (**K** Reiff, pres.; George W. Reiff, treas.; Ladies' Elastic Ribbed Underwear; 40 knitting machines; steam; sell direct; Geo. W. Reiff, buyer.
- CHESTER KNITTING CO; H. E. Rogers, (**K** supt. and buyer; Men's Cotton Ribbed Underwear; 9 knitting machines; steam; sell direct and Isaac P. Graff & Co, 346 Broadway, N. Y., s. agts. (Buy white, silver gray, stained, Egyptian and combed Egyptian in 7s and 8s, mule spun.)
- NATIONAL UNDERWEAR CO; (inc. 1896); (**K** \$25,000; John T. Langham, pres; Ladies' Ribbed Underwear; 25 knitting and 20 sewing machines; steam; sell direct and through agents.
- URNER, W. C. & CO; Spring City Hos (**K** & **D** iery Mills; Full Fashioned and Seamless Hosiery; 500 cylinders; 4 sets full fashioned machines; steam; also Dyers and Extract and Print Hosiery; sell direct; W. C. Fitzgerald, salesman; N. Y. office N. Y. Life Bldg. Room 925, and C. H. Swearingen, Pittsburg, J. W. B. Carson, Phila., s. agts.; W. C. Urner, buyer. (Buy 2 ply and single combed Egyptian and carded Peeler, 8 to 80.)
- Steelton.** H-11. Phila. Div. Penn. RR; Steelton branch, Phila. and Reading RR. Penn. Canal.
- DAUPHIN HOSEIERY CO (successors to (**K** Shaar & Rhodes Hosiery Co.); E. H. Hirner, pres; Sam'l Couffer, treas; Jos. B. Rhodes, supt. and buyer; Cotton Half Hose, 84 needle; 34 knitting machines; 6 ribbers; 3 loopers; electricity; Robt. P. Steele, s. agt. (Buy white cotton mixed and waste yarns.)
- STEELTON HOSEIERY MILLS; Frank T. (**K** McElroy, prop; 120 No. Front St; Men's Half Hose (84 needle); 32 knitting machines; steam; John M. Given, Pittsburg, s. agt; F. T. McElroy, buyer. (Buy 6 and 8 white yarn, 20 blue and white, 20 brown and white and 20 red and white.)
- Stoyestown.** J-5. B. & O. RR; Somerset and Cambria RR.
- RININGER, WM. L. SOXS; (P. O. address, (**W** Kantner); Woolen Goods, Yarns and Carpet; 2 sets; 5 looms; water; dye; Wm. L. Rininger and J. B. Williams, s. agts; Wm. L. Rininger, buyer.
- Stroudsburg.** F-15. D. L. & W. RR; N. Y. S. & W. RR; Stroudsburg Br; Wilkesbarre & Eastern RR.
- GILBERT, WM. A. CO; \$50,000; W. B. Eas. (**S** ton, pres.; Wm. A. Gilbert, treas., supt. and buyer; Thrown Silk on Commission; 24,000 spindles; steam.
- KITSON, THOS. & SON; Thos. J. Kitson, (**W** prop.; Chevriots, Cassimeres, Cloakings, etc; 12 sets; 60 looms; steam and water; dye; Schefer, Schramm & Vogel, 476 Broome St, N. Y., s. agts.; Thos. J. Kitson, buyer.
- Sunbury.** F-11. N. C. RR; Penn. RR; Phila. & R. RR.
- SLEAR BROS.; Sunbury Hosiery Mills; (**K** successors to P. W. B. Eckert); Slear's Brotherhood Hosiery in Egyptian Thread for Men, Women and Children; 15 knitting machines; 4 ribbers; 2 loopers; steam; sell direct.
- SUSQUEHANNA SILK MILLS; \$150,000; H. (**S** Schwiewind, sr, pres; H. Schwiewind, Jr, treas; Max Stepermann, sec; Heinrich Klerx, supt; Silk and Silk and Cotton Mixed Goods; 500 looms; steam; Max Stepermann, 57 Greene St, N. Y., s. agt; Heinrich Klerx, buyer. (See also Marion, Ohio.)
- SUNBURY WORSTED SPINNING CO; \$16,- (**W** 000; Johnson B. Miller, pres; Geo. H. Gibson, treas; Worsted Yarns for Braids, Waps, Hosiery, Golf and Dress Goods Trade; 800 worsted spindles; steam.
- Swarthmore.** J-15. P. W. & B. Central Div.
- VICTORIA PLUSH MILL; \$75,000; Edward (**S** F. Timme, pres; Arthur Turner, vice-pres; Otto Timme, treas; John Turner, sec; Velours, Corduroys, Velvets and Plushes; steam; dye; E. F. Timme & Son, N. Y., s. agts. (Finishing plant at Pater-son, N. J.)
- Swedeland.** J-15. Phila. & Reading RR.
- MARKLAND & ROESSLER; Shoddy; 6 (**W** cards; 3 pickers; steam; Lewis W. Roessler, buyer.
- Taylor.** D-14. C. of N. J. RR. and Del. & L. RR.
- LAURIER SONS SILK CO; \$25,000; W. R. (**S** Lewis, pres; P. A. Loubignac, treas. and buyer; Silk Weaving; steam; sell direct. (Reported to start *Mar.*, 1902.)
- RENARD, & CO; Com. Throwing; 10,000 (**S** spindles; steam.
- TAYLOR WORSTED CO; \$40,000; P. Mul- (**S** herin, pres; Jas. P. Law, sec; Martin C. Judge, treas; Jas. A. Hannigan, supt; Dress Silks; 68 looms; H. A. Caesar & Co, N. Y., s. agts.
- Tippecanoe.** J-3. P. RR, Redstone Br.
- COOK, T. & R. P.; R. P. Cook, supt; (**W** & **K** Blankets, Flannels, Yarns, Cassimeres and Stockings; 1 set; 5 looms; 8 knitting machines; steam and water; dye; R. P. Cook, buyer.
- Titusville.** C-3. D. A. V. & P. RR; W. N. Y. & P. RR.



- FULMER, D. A; Hosiery; 6 knitting ma. (K) chines.
- HORN SILK CO, CHAS; \$160,000; A. P. (S) Cooley, sec. and treas; Chas. Horn, mgr; Silk Ribbons; 6000 spindles; 15 looms; steam; dye; James Talcott, N. Y., s. agt.
- Topton.** G-14. P. & R. RR.
- HARTLEY SILK MFG. CO; Dress and Tie (S) Silks; 50 looms. (See Alburtis.)
- Towanda.** C-12. Barclay RR; L. V. RR, North Branch Div; State Line & Sullivan Br.
- TOWANDA KNITTING MILLS; W. J. (K) Young; James Shelton, Jr., supt.; Men's and Ladies' Fancy Lace Hosiery; 12 knitting machines; steam; dye; J. C. Remy & Co., s. agts.
- Trainer.** K-15. P. W. & B. RR, Maryland Div.
- TRAINER, T. W.; (formerly D. Trainer & (C) Sons Mfg. Co; Fine Cotton Dress Goods; 600 looms; steam; dye.
- TRAINER SPINNING CO.; T. Ashly Blythe, (C) pres.; N. B. Sloan, treas.; Wm. E. Trainer, supt. and gen'l mgr.; Yarns; 30,000 spindles. (Operating mill formerly run by D. Trainer & Sons Mfg. Co.)
- Tremont.** G-12. Tremont Branch Phila. & Read. RR; Pottsville Junc. & Tremont RR.
- DEVANEY BROS; \$5,000; Ladies' Seamless (K) Hosiery; 28 knitting machines; steam; McPavitt & Corlozo, 47 Leonard St., N. N., s. agts.
- LAUX, J. A; Tremont Hosiery Mill; Cot. (K) ton Hosiery; 12 knitting machines; 1 sewing machine; steam.
- Trevorton.** F II. Shamokin Br. P. & R. RR.
- TREVORTON SILK MILL; Theo. A. Wagner, (S) sec.
- Troy.** C-II. N. C. R. RR.
- TROY KNITTING CO; (successors to (K) North Woolen Mfg. Co); Wm. F. DeWitt, pres; H. K. Mitchell, treas; Ladies' and Men's Fine Wool Hosiery, also Fine Worsted Goods; 2 sets; 800 spindles; 30 knitting machines; steam; sell direct.
- Trucksville.** D-13. L. V. RR, Harvey's Lake Br.
- WILLIAMS, M. & C; Domestic Woolens; (W) 1 set; 4 looms; dye.
- Tunkhannock.** D-13. Lehigh Valley RR.
- WINOLA WORSTED YARN CO; \$50,000; (W) D. W. Stark, pres; C. A. Hungerford, treas; Samuel Feather, supt; Worsted Yarns; 1344 worsted spindles; 1 comb; (English system); 1 worsted card; steam; sell direct.
- Upland.** K-15. B. & O. RR, Phila. Div; P. W. & B. RR, Chester Creek Line.
- CROZER'S, J. P. SONS; Upland Mills; (C) Plaids, Checks, Stripes; 20,000 spindles; 530 looms; steam and water; dye. *Mill idle; not run for six years.*
- CROZER, S. A. & SONS; (warp mill at Ches. (C) ter); Cotton Goods for Export; 17,000 ring spindles; 566 looms; steam; dye; Faulkner, Page & Co., 60 Worth St, N. Y., s. agts; firm, buyers. (Buy 20s yarn sometime.)
- WALLWORTH, J. & SONS; Shoddy and (W) Waste; 3 pickers; 3 sets; 1 willow; 2 waste pullers; steam; Phila. office, 221 Chestnut St.
- Upper Black Eddy.** G-15. B. R. RR.
- HERO KNITTING MILLS. *Out of business.*
- Wallingford.** J-15. P. W. & B. RR, Central Div.
- COLUMBIA WORSTED CO; \$60,000; Henry (W) T. Kent, pres, and treas; N. S. Keay, sec; E. Craven, mgr; Dress Goods and Worsted Yarns (English system); 5 combs; 2,500 worsted spindles; 30 broad looms; steam and water; dye; sell direct; Phila. office, 403 Provident Bldg. (Also branch at Todmorden.)
- Waterside.** H-7. P. RR, Morrison's Cove Br.
- WOODCOCK & CURRY; James Curry, (W&K) supt.; Cassimeres, Woolen Blankets, Flannels, Skirts, Satinet Yarns and Woolen Hosiery; 1 set; 7 looms; 5 knitting machines; water; dye; sell direct; A. B. Woodcock and James Curry, buyer.
- Wayne.** J-15. Pa. RR.
- RADSOR HOSEIERY MILLS; Sold to J. W. (K) Hanes and moved to Winston, Salem, which see.)
- Waynesboro.** K-9. C. V. RR.
- WAYNESBORO HOSEIERY MILL; D. F. (K) Beaver, prop.; W. B. Railing, mgr.; Hosiery; 26 knitting machines; 7 ribbers; steam; sell direct. (Formerly at Mechanicsburg.)
- Weatherly.** F-13. L. V. RR, Beaver Meadow Br; Hazleton Br.
- READ & LOVATT CO, THE; J. C. Read, (S) pres; J. Walter Lovatt, treas; W. B. Lovatt, supt; Throwsters; 41,000 spindles; steam. (*Also at Elmira, N. Y.*)
- Weissport.** F-4. C. R. R. of N. J.
- STORMS, A. L. & CO; \$5,000; A. L. (S) Storms, pres, and supt; W. G. Miller, treas; Tram Throwing on Commission; 1,000 spindles; electric power; A. L. Storms, buyer.
- Wellshoro.** C-9. F. B. C. Co.'s Corning, Cowanesque & Ant. Div.
- WHITE, OLIVER L; Rolls and Batts; (W) 1 set; steam.
- Wellsville.** J-10. C. V. RR..
- PENNSYLVANIA NET CO; Leather and (C) Cotton Fly Nets; steam. (RR. Station, Dillsburg.)
- Wernersville.** H-13. P. & R. RR, Lebanon Valley Br.
- HAIN, J. ULYSSES; Half Hose; 10 knit. (K) ting machines; steam; Charles W. Bartsch, N. Y., s. agt.
- West Conshohocken.** J-15. P. & R. RR.
- CONSHOHOCKEN WOOLEN CO; \$290,000; (W) Horace C. Jones, pres; Elbridge McFarland, treas; Roscoe K. Moir, gen'l mgr; Walter D. West, supt; Men's Wear and Cloakings; 13 sets; 78 looms; steam; dye; H. & W. H. Lewis, N. Y. and Phila., s. agts; Roscoe K. Moir, buyer.
- GEORGE MCFARLAND COMPANY; Gulf (W) Woolen Mills; \$50,000; Elbridge McFarland, pres; John McFarland, treas; Frank L. Jones, supt; Cassimeres, Etc; 6 sets; 50 narrow looms, 20 broad; steam and water; dye; Schnabel Bros, N. Y., s. agts; Elbridge McFarland, buyer. (Sometimes buy 2/30 or 2/20 cotton yarns.)
- MERION WORSTED MILLS; \$250,000; (W) J. Willard Morgan, pres; C. Harrigan, treas; M. Harrigan, supt; Dry Spun Worsted Yarns, (French system); 12 sets; 24 combs; 12,000 spindles; sell direct; C. Harrigan, buyer.
- West Earl.** J-12. P. R. RR; Downington & Lancaster RR; P. & R. RR.
- ZOOK, J. O. K; Cassimeres, Blankets, (W) Knitting Yarns, Etc; 1 set; 4 looms; water; dye; sell direct. (Shipping Sta. Millway, Read, & Col. RR.)
- West Lebanon.** G-4. P. RR.
- HART, J. A; Woolens; Flannels and (W) Knitting Yarns; 1 set; 3 looms; steam; dye; sell direct.
- White Haven.** E-4. C. R. R. of N. J.
- WHITE HAVEN SILK CO; Frank Frigerio, (S) pres, and mgr; Peter Magagna, sec. and treas; Organzine, Grenadine and Crepe de Chine Twist a Specialty; 3,500 spindles; steam.

**Wiconisco.** G-II. N. C. RR, Shamokin Div.

**MOSSOP, ISAAC & Co;** Wiconisco Hos. (K) lery Mill; Cotton Hosiery; 150 knitting machines; steam; sell direct and H. C. Smith, Phila, J. Van Wyck Du Bois, N. Y. s. agts; Isaac Mossop, buyer. (Buy 6, 9, 10, 12, 16, 17, 30s yarn.)

**SHEAFER, W. H.;** Knit Goods. (K)

**WICONISCO DYING & MFG. Co.;** \$50,000; (D) L. K. Diefenderfer, pres; Isaac Mossop, treas; Fritz Schott, supt. and buyer; Dyers of Fast Black and Fancy Colors Cotton Hosiery; steam.

**Wilkesbarre.** E-13. C. RR. of N. J.; D. & H. RR, Penn. Div.; D. L. & W. RR, Bloomsburg Div.; E. & W. V. RR; L. V. RR, Wyoming Div.; N. Y. S. & W. RR; Wilkesbarre & Eastern RR; P. RR; North & West Branch Ry.

**BAMFORD BROS. SILK MFG. Co.;** (See Pater. (S) son, N. J.) Wilkesbarre mill reported for sale.

**FIRWOOD LACE & TRIMMING Co;** \$50. (C) 000; E. F. Cooke, pres; Henry Merritt, treas; James A. Dodd, gen'l mgr; Valenciennes Laces, Allovers, Torchons, etc; steam; bleach; sell direct. (Buy 180/2, 170/2 Gassed and Prepared 50/2 combed Peeler; will use 120/2 plain prepared later.

**HESS, GOLDSMITH & Co.;** J. A. Gold. (S) smith, supt; Broad Silks; 3,000 spindles; 600 looms; steam; sell direct; 53 Greene St, N. Y.; J. A. Goldsmith, buyer.

**MORGAN, WM. P.;** Cotton Half Hose, (K) White Feet, Randoms, also Colored Heels and Toes, Embroidered Work, etc.; 158 knitting machines; 17 ribbers; 15 loopers; steam; dye; sell through agents. (Buy yarn 11s, 13, 26, 40, skeins and cones. (Mill at Kingston.)

**REMSEN, GEORGE. W. & Co.;** 421 and 423 (D) McLean St. Dyers of Hosiery and Yarns, Discharge Printing on Colored Hosiery; steam; Geo. W. Remsen, buyer.

**SUN NARROW FABRIC Co. THE;** \$50,000; (C) E. P. Phillips, pres. and treas; H. Mattershead, mgr.; Tapes, Braids and Bindings; steam; dye; sell direct; H. Mattershead, buyer.

**WILKESBARRE KNITTING MILLS Co.;** (K) \$100,000; Jesse T Morgan, pres.; J. Roberts, Jr., sec. and treas.; Wm. Menzies, gen'l mgr.; Misses' Ribbed Hose, Men's Seamless Half Hose, Ladies' and Infants' Lace Hose (fine grades) Mercerized; 225 knitting machines; steam; dye.

**WILKESBARRE LACE MFG. Co.;** \$500,000; (C) J. W. Hollenback, pres; Clarence Whitman, treas; John W. Doran, mgr; Lace Curtains, Curtain Nets, Braids, Tapes and Yarns; 30,000 spindles; 725 braid machines; 26 looms; 83 lace machines; 125 sewing machines; steam; dye; Clarence Whitman & Co, 41 Leonard St, N. Y. s. agts.

**WYOMING VALLEY LACE MILLS.;** (C & S) \$250,000; W. J. Harvey, pres; J. C. Atkin, mgr; R. R. Harvey, supt.; Lace Curtains; 16 looms; steam; dye; sell direct, J. C. Atkin, buyer.

**Williamsport.** E-10. B. C. RR; F. B. C. Co's RR, Pine Creek Div; N. C. RR, Elmira Div. Susquehanna Div; P. RR, Sunbury & Driftwood Line; P. & R. RR, Catawissa & Williamsport Br.

**HOLMES SILK Co;** Lycoming Silk Mills; (S) G. W. Demorest, supt.; Silk Dress Goods; 215 looms. (Also see Paterson, N. J.)

**HOLTSIZER, H. E. AND J. C.;** Holtziser. (W) port Woolen Mills; H. E. Holtziser, supt. and buyer; Woolens and Worsteds; 2 sets; 11 looms; steam; dye; sell direct; both, buyers. (Buy worsted yarn 2/15 to 2/40s.)

**ROYAL BRAID Co;** \$25,000; G. B. Merrill, (C) pres.; R. W. Gibson, sec., treas., and

supt; Silk, Cotton, Mohair and Worsted Suspender Braids; Dress Braids and Novelties; 500 braiding machines; steam; sell suspender braids direct.

**STEARNS, JOHN N. & Co;** (of N. Y.) Piece (S) Silks, Serges, Etc; 600 looms; steam; sales-room, 68 Greene St, N. Y.; also Petersburg, Va. and Elmira, N. Y.

**SUSQUEHANNA DYE WORKS;** \$250,000; (D) (Under construction)

**Williamstown.** G-II. N. C. RR, Summit Br; W. V. RR.

**DIAMOND KNITTING MILLS;** Hoffman & (K) Shelton; Ladies', Misses' and Children's Cotton Underwear; 20 knitting machines; steam; dye and bleach; sell direct and C. H. Swearingen, Pittsburgh, L. J. Riggins, N. Y., Parks & Meecher, N. Y., s. agts; both, buyers.

**DURBIN, J. W. & SONS;** Williamstown (K) Hosiery Mill; Half Hose, Blacks and Tans; 90 knitting machines; steam; Lindsay J. Riggins, N. Y. s. agt; J. W. Durbin, buyer.

**Womelsdorf.** H-12. P. & R. RR, Lebanon Valley Br.

**HIESTER & HIRST;** Seamless Half Hose; (K) 31 knitting machines; steam; sell direct. MOYER, J. J. J; Hosiery Knitter; sell di. (K) rect.

**RUTH, S. S.;** Men's Half Hose; 4 knitters. (K) Woodbury. H-6. See Maria.

**Woolrich.** E-9. B. C. RR; P. RR, Sunbury & Driftwood Line; Bald Eagle Valley RR.

**RICH, JOHN, & BROS;** Blankets, (W & K) Flannels, Mitts, Hosiery and Yarns; 2 sets; 18 looms; 27 knitting and 9 sewing machines; steam; dye; sell direct.

**Worthington.** F-3. A. V. RR.

**GRAFF, PETER & Co;** Buffalo Woolen (W) Mills; J. E. Claypool, supt; Yarns, Blankets and Flannels; 2 sets; 1200 mule spindles; 18 looms; gas engine; dye; sell direct; firm buyers.

**Yardley.** H-16. P. & R. RR.

**COLD SPRING BLEACHING & FINISH. (B1 & F) ING WKS;** \$100,000; Theodore C. Search, pres; Oscar W. White, treas; Jas. F. McMahon, supt; Bleaching and Finishing of Cotton Goods; steam. (Office 32 So. Broad St., Phila.)

**York.** J-II. B. & L. RR; W. M. RR, Eastern Extension; N. C. RR, Baltimore Div; P. RR.

**ASHLEY & BAILEY Co;** (main office, Pat. (S) erson, N. J.) Dress Silks, Ribbons, Etc; 100 looms; steam. Also Marietta and Columbia, Pa. and Fayetteville, N. C.

**BLACK, JOS. & SONS Co;** \$150,000; Joseph (K) Black, Sr., pres; Robt. L. Shelter, treas; Walter Black, sec; Joseph Black, Jr., supt.; Misses', Infants' and Men's Hosiery; 350 knitting machines and cylinders; steam; dye; sell direct and Thos. S. Fuller, 70-72 Franklin St., N. Y., s. agt.; Walter Black, buyer. (Buy 11s to 40s yarn.)

**DIAMOND SILK MILL;** Branch; Silk Throw. (S) ing on Commission; Organzine, Tram, Floss, Fringe, Twist, etc.; steam. See York Silk Mfg. Co.

**FRYSSINGER, FRANK;** York Carpet Mills; (W) J. Schwartz, supt.; Rag and Jute Carpets; 38 looms; hand and gas power; sell direct; Frank Fryssinger, buyer. (Buy 8/3, 12/2, 4/4, 4/3 cotton and woolen yarns and jute.)

**MONARCH SILK Co;** \$100,000; Henry Mus. (S) ser, pres.; G. W. Reider, treas.; Sydney H. Souther, mgr.; Dress and Tie Silk; 10,000 spindles; 150 looms; steam; sell direct; firm, buyers. (Buy cotton yarn, 20/2 to 60/2, combed and carded.)

WARNECKE, A. F.; Rag and Yarn Car. (**W** pets and Rugs; 7 looms; steam; dye; sell direct. (But woolen, cotton and jute yarns.)

YORK KNITTING MILLS Co.; \$50,000; Hon. (**K** W. F. Bay Stewart, pres.; J. J. Shelmore, treas.; Henry L. Field, sec. and gen. mgr.; F. J. Cartledge, supt.; Men's, Ladies' and Children's Seamless Hosiery; 150 knitting machines; 51 ribbers; 21 loopers;

steam; dye; sell direct. (Buy 10, 11, 15, 18, 20, 26, 27 and 30 combed and carded yarn.)

YORK SILK MFG. Co.; \$1,800,000; D. F. La. (**S** feuau, pres.; C. H. Emig, treas.; M. G. Collins, agt. and gen'l mgr.; Chas. Steiner, supt.; Dress Silks; 50,000 spindles; 1,000 looms; Spielmann & Co., s. agts.; M. G. Collins, buyer. (Branch mills at Carlisle, Pa., Electwood, Pa., Diamond Silk Mill and York and Windsor Mills, York, Pa.)

## RHODE ISLAND.

See map on page 252.

For explanation of abbreviations see page 66.

**Albion.** A-II. N. Y., N. H. & H. RR.

VALLEY FALLS Co.; \$180,000; A. B. Chace, (**C** treas.; M. G. Chace, agt.; Cotton Goods; 40,000 spindles; 975 looms; water and steam; sell direct. (P. O. address, Valley Falls.)

**Allenton.** D-II. Station at Wickford Junction, on N. Y., N. H. & H. RR.

BELLEVILLE WOOLEN MILL; \$20,000; J. R. (**W** Wilson, pres. and supt.; James W. Lees, treas.; Jas. Geo. Murray, sec.; Fancy Cassimeres; 8 sets; 38 looms; steam and water; Wendell, Fay & Co., Boston and N. Y., s. agts.

RODMAN MFG. Co.; Silver Spring Mill; (**W** Chas. F. Sherman, supt.; Doeskins, Jeans, etc.; 5 sets; 80 looms; steam and water; dye; P. Van Volkenburgh & Co, s. agts. Also Lafayette, which see.

RODMAN MFG. Co.; Shady Lea Mill; Al- (**C** bert Rodman, pres.; Walter Rodman, treas.; Robt. A. Gray, supt.; Colored Warps, Gray Warps in Chains on Beams and Skeins, single and 2 ply; 9000 spindles; steam and water; dye; sell direct; Walter Rodman, buyer. See Lafayette.

**Alledale.** B-II. N. Y., N. H. & H. RR.

ALLEDALE Co. See No. Providence. (**C**

**Anthony.** C-II. N. Y., N. H. & H. Cen. Div.

ANDREWS, ALBERT J. (formerly E. L. (**C** Anthony); Banding, Rope and Twine; steam and water; sell direct.

COVENTRY Co.; (20 Market Sq., Prov.); R. (**C** Gardner, pres.; Robt. W. Taft, treas.; H. L. Strait, supt.; Sheetings, Cotton Fancies and Twills; 18,176 ring and 19,968 mule spindles; 916 looms; water and steam; sell direct.

QUINICK MFG. Co.; \$300,000; Jeffrey (**C** Davis, pres.; Jno. H. Hamby, treas.; E. I. Knight, supt.; Cotton Goods, Plain and Odd for Converting Trade; 41,232 spindles; 1026 looms; water and steam; sell direct. Office, Industrial Trust Building, Prov.

**Apponaug.** C-II. N. Y., N. H. & H. RR.

ORIENTAL PRINT WORKS; W. (**P**, **B1** & **D** W. Dunnell (formerly Apponaug Print Works); 9 printing machines; steam.

**Arcadia.** D-10. Stage at Hope Valley, on Wood River Br. RR.

ROGER WILLIAMS COTTON MILLS; Geo. (**C** W. MacFutcheon, pres.; J. N. Gerard, sec. and treas.; Geo. C. Gordon, agt.; J. B. Clark, supt.; Print Cloths and Sheetings; 10,000 spindles; 211 looms; water and steam; Haines & Bishop, N. Y., s. agts.; Geo. C. Gordon, buyer.

**Arkwright.** C-II. 1/2 mile north of Harris, N. Y., N. H. & H. RR.

INTERLAKEN MILLS; Book Cloths; steam (**C** and water; dye; sell direct. (For machinery see Phenix).

**Ashaway.** E-9. Stage 6m. at Westerly, on N. Y., N. H. & H. RR, Ston. Div.

ASHAWAY LINE & TWINE MFG. Co.; \$50,000; (**C** Edwin G. Carpenter, pres. and supt.; G. B. Carpenter, treas.; C. F. Randolph, sec.; Silk, Linen and Cotton Fishing Lines, Twines and Cordage; steam and water; dye; sell direct.

ASHAWAY WOOLEN Co.; \$100,000; L. A. (**W** Briggs, treas.; Jas. W. Murphy, supt.; Suitings; 11 sets; 84 looms; water and steam; dye; Fred'k Victor & Achelis and Devoe & Peck, N. Y., s. agts.; L. A. Briggs, buyer.

**Ashton.** A-II. N. Y., N. H. & H. RR, Wor. Div.

ASHTON MILLS; operated by Lonsdale (**C** Co.; Lonsdale, which see; Wm Goddard, treas.; A. H. Gulliver, supt.; Sheetings.

**Bellefont.** C-II. N. Y., N. H. & H. RR.

WHITTLE DYE WORKS; W. E. Whittle, (**D** & **F** pres.; T. P. Himes, treas.; A. Ewart, supt.; Dyers and Finishers Cotton Piece Goods; steam; sell direct. (P. O. address, Providence; freight address, Auburn, R. I.)

**Berkeley.** A-II. N. Y., N. H. & H. RR.

BERKELEY Co.; \$600,000; Wm. God. (**C** dard, pres.; R. H. I. Goddard, treas.; Sturges & Gammell (Prov.), agts.; Chas. H. Collins, supt.; Cambries, Lawns, Nainsooks and Fine Cottons; 32,256 ring and 19,240 mule spindles; 1,184 looms; steam; Moss, Taylor & Co., N. Y., s. agts.; Sturges & Gammell, buyers. (Office and P. O. address, Providence, R. I.)

**Bridgeton.** A-10. N. Y., N. H. & H. RR Cen. Div.

LAUREL HILL YARN Co.; \$25,000; O. T. In- (**W** man, agt.; J. H. Fairbrother, supt.; Woolen and Merino Yarns; 4 sets; steam and water; sell direct and W. F. Slade Co., s. agts.; O. T. Inman, buyer.

PRENDERGAST, Wm. H. O. Gilleran, supt.; (**W** Fancy Worsteds for Men's Wear; 54 looms; steam and water; Duval & Cone, 79 Worth St., N. Y., s. agts.; Wm. H. Prendergast, buyer. (Buy worsted yarn, mostly 2/40 and 2/50; and cotton 2/42 to 2/50.)

SAXONDALE WORSTED MILLS. *Out of business; Millburned Nov., 1901.*

WILSON, HERBERT M.; Yarns and Shod- (**W** dy; 2 sets; 6 shoddy cards; 2 pickers; water and steam.

**Bristol.** C-12. N. Y., N. H. & H. RR, Wor. Div. and F. R. & P. Steamboat Co.

CRANSTON WORSTED MILLS; \$100,000; (**W** Chas. B. Rockwell, treas.; Worsted, Mohair and Novelty Yarns (B adford system); 9 sets; 7 combs; steam; dye; sell direct.

RICHMOND MFG. Co.; Namquit Mill; (P. O., (**C** address Prov., R. I.); G. Richmond Parsons, pres.; F. E. Richmond, treas.; Eber

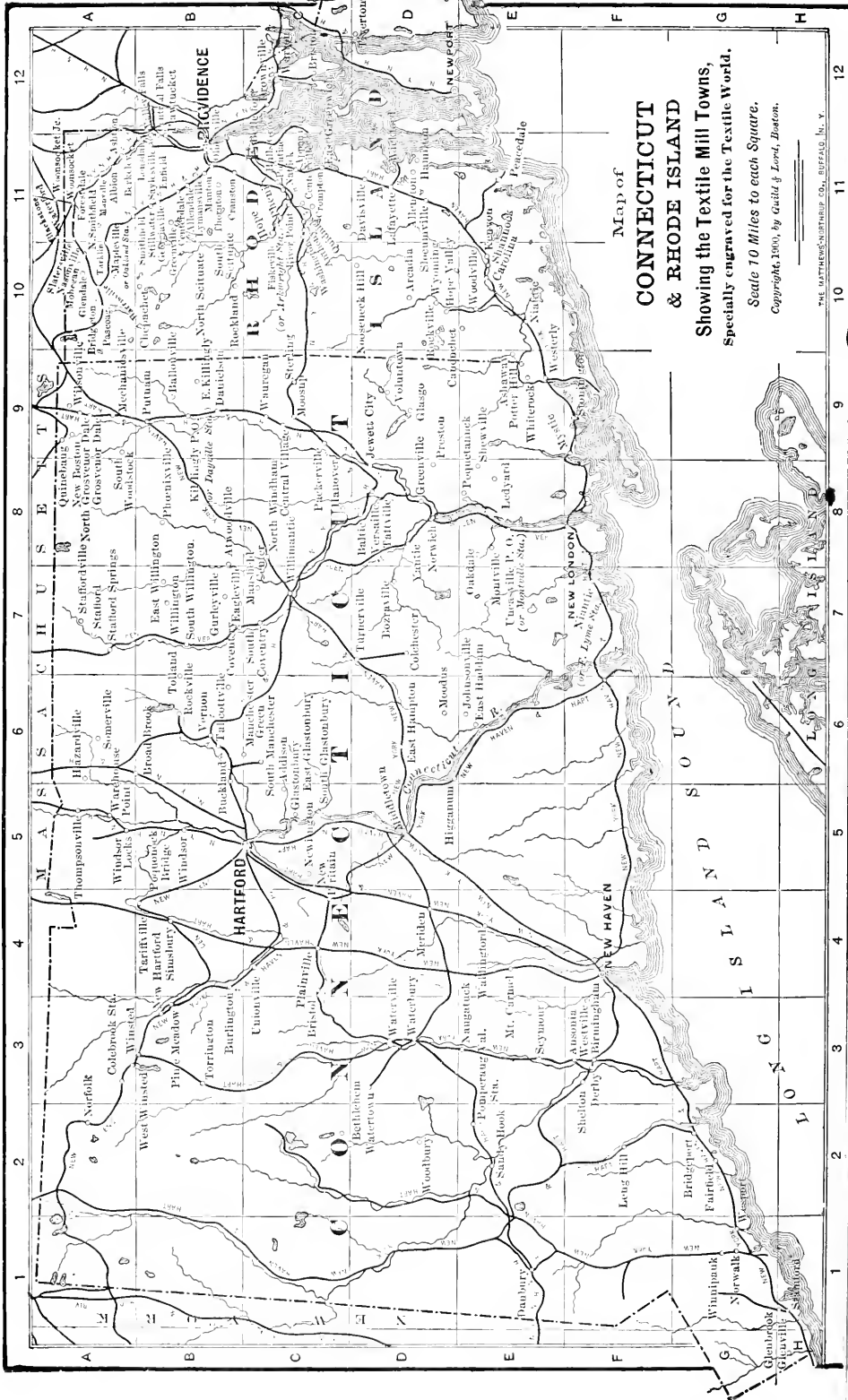

Map of  
**CONNECTICUT  
 & RHODE ISLAND**

**Showing the Textile Mill Towns,  
 Specially engraved for the Textile World.**

Scale 10 Miles to each Square.  
 Copyright, 1900, by Gust & Lord, Boston.

Hill, supt; Print Cloths; 10,880 ring spindles; 306 looms; steam; sell direct; F. E. Richmond and E. Hill, buyers.

**Burrillville.** See Mapleville, Mohegan and Pascoag.

**Canochet.** E-10. Wood Riv. Br. RR.

CANOCHEMILLS, L. E. Edwards; Yarn (C and Warps; 3000 spindles; water and steam.

EDWARDS, JAMES R, Estate of; O. Ed. (C wards, supt; Yarns; 1000 ring spindles; steam and water.

GATES, ISRAEL; Twine, Lines, etc; (C & S water and steam; sell direct.

**Carolina.** E-10. N. Y, N. H. & H. RR, Ston. Div.

CAROLINA MILLS CO; \$100,000; E. Tink. (W ham, pres; F. Metcalf, treas; W. Metcalf, asst. treas and mgr; H. C. Bailey, supt; Fancy Cassimeres and Overcoatings; 8 sets; 50 looms; water and steam; dye; Fred'k Victor & Achelis, N. Y, s. agts; W. Metcalf, buyer. (Buy cotton yarns, 30/1, 60/1, 14/2 and some others in smaller quantities.)

**Central Falls.** B-II. N. Y, N. H. & H. RR, Wor. & Prov. Div.

FARWELL WORSTED MILLS; F. S. Far. (W well, pres, and treas; J. H. Merrill, supt; Fancy Worsted Goods for Men's Wear; 8 sets; 150 looms; water and steam; dye; Stevens, Sampford & Handy, and Callender & Austin, N. Y, s. agts. F. S. Farwell and C. W. Barnes, buyers. (Also Middleboro, Mass.)

STAFFORD MFG CO; \$150,000; J. F. Adams, (C pres; R. S. Adams, treas; J. F. Adams, agt; Herbert M. Adams, supt; Cotton Yarns; 5,760 ring and 7,974 mule spindles; steam and water; W. M. & F. W. Sharples, 123 Chestnut St, Phila, s. agts; also sell direct; J. F. Adams, buyer.

U. S. COTTON CO; \$500,000; LeRoy Fales, (C pres; S. A. Jenks, treas; L. B. Barker, agt; David Grove, supt; Print Cloths and Odd Goods; 58630 ring spindles; 1600 looms; steam; sell direct; L. B. Barker, buyer.

**Centerdale.** B-II. N. Y, N. H. & H. RR, Cen. Div.

CAMPBELL, JAMES; Greystone Mills; (W Wool Shoddy and Extract; 3 pickers; 18 cards; (office 84 Westminster St, Prov.)

CENTREDALE WORSTED MILLS; \$100,000; (W W. A. Mackie, pres, and supt; Jas. Lister, Jr, treas; Wm. Dracup, sec; Worsted Yarns 20s to 50s; 15 combs (English System); 15 worsted cards; 12,600 worsted spindles; steam and water; sell direct; James Lister, Jr, buyer wools; W. A. Mackie, supplies. (Above data includes plant at Stillwater.)

**Centerville.** C-II. N. Y, N. H. & H. RR, Cen. Div.

CENTERVILLE COTTON MILL, Robert B. (C Treat, prop; John B. Allen, supt; Shi-tings and Sheetings; 21,056 ring and 9,792 mule spindles; 722 looms; water and steam; Treat & Converse, and R. W. Anderson, N. Y, Edward Shaw, 2d, Prov., s. agts; R. B. Treat, buyer.

KENT MFG. CO; \$100,000; R. E. Water. (W house, pres; Geo. B. Waterhouse, treas; R. E. Waterhouse, supt; Cassimeres, Mellons and Worsteds; 8 sets; 71 looms; steam; dye; Bacon & Co, N. Y, s. agts; R. E. Waterhouse, buyer. (Buy worsted yarns from 2/18 to 2/40.)

SHIPPEE, H. A; Steam Knitting Mill; (K Men's Women's and Children's Seamless Hosiery and Knit Bandages, 72, 124, 138, 160 needle goods; 6 knitting and 2 sewing machines; steam; sell direct; H. A. Shippee, buyer. (Buy Nos. 5s, 10s, 20s 21s colored cotton yarns, and 5-10s natural.)

WARWICK MILLS; \$100,000; R. B. Sewall, (C pres; E. B. Townsend, treas; J. T. Ferguson, supt; Fine Lawns, Sateens, etc; 20,488 mule and 16,800 ring spindles; 806 looms; steam; Wellington Sears & Co, s. agts.

**Chepachet.** B-10. R. R. station Mapleville, N. Y, N. H. & H. RR, Cen. Div.

CHEPACHET YARN CO.; Woolen Yarn, (W All Sizes; 5 sets; steam and water; sell direct.

MELLOR, ABRAHAM. (W

**Cranston.** B-II. N. Y, N. H. & H. RR, Cent. & Taunton Divs.

CRANSTON PRINT WORKS CO; \$300,000; (P Robert Knight, pres; John B. Anthony, treas; Lyman B. Frieze, agt, and mgr; Printers of Cotton Fabrics; steam; dye.

**Crompton.** C-II. Station at Centreville on N. Y, N. H. & H. RR.

CROMPTON CO; \$400,000; F. E. Rich- (C D & F mond, pres; Howard Richmond, treas; C. D. Robinson, supt; Corduroys and Velveteens and few Printing Cloths; 40,000 spindles; 1000 looms; water and steam; dye; J. H. Fifield & Co, N. Y, s. agts. (Also Dyers and Finishers.)

**Davisville.** D-II. N. Y, N. H. & H. RR, Ston. Div.

REYNOLDS MFG. CO; H. J. Kennedy, (W supt; Jeans, Doeskins and Cassimeres; 4-sets; 26 narrow and 11 broad looms; water and steam; dye; sell direct and Fred'k Victor & Achelis, s. agts; firm, buyers.

**Drownville.** C-12. N. Y, N. H. & H. RR.

ANAWAMSCOTT MILLS; \$100,000; J. (D & F W. O'Bannon, pres; L. W. Bagley, treas; Geo. B. Frost, supt; Gook Cloths; steam; dye; The J. W. O'Bannon Co, s. agts; J. W. O'Bannon, buyer. (P. O. Address Providence.)

**East Greenwich.** C-II. N. Y, N. H. & H. RR, Ston. Div.

GREENWICH BLEACHERY, THE; \$100. (B I & F 000; John W. Coreoran, pres; Peter H. Corr, treas; F. E. Burbank, gen'l mgr; Bleaching and Finishing; steam; sell direct; F. E. Burbank, buyer.

ELIZABETH MILLS CO; mill No. 2; (C Thread Yarns; 7854 spindles; steam; sell direct. Also mill No. 1 at Hills Grove.

PHENIX MILLS; Samuel Williams (Bos. (W ton), treas; 9 sets; 87 looms; steam; dye; Not running. Machinery being sold.

**Enfield.** B-II. N. Y, N. H. & H. RR, Cent. Div.

ENFIELD MILLS; W. H. Pope (4 Market (C Sq, Prov.), treas; C. P. Lincoln, supt; Plain and Fancy Cotton Goods; 5,416 ring and 5,120 mule spindles; 220 looms; water and steam; Wm. H. Pope, buyer.

**Fiskville.** C-II. N. Y, N. H. & H. RR, Ston. Div.

FISKVILLE MILL; B. B. & R. Knight; (C Sheetings; 4000 spindles; 100 looms; water. Closed indefinitely.

JACKSON MILLS; B. B. & R. Knight; Geo. (C H. Corey, supt; Sheetings, Shirtings, Linings and Twills; 2,180 ring and 2,220 mule spindles; 120 looms; steam and water; sell direct from Prov. office.

**Forestdale.** A-II. N. Y, N. H. & H. RR, Mid Div.

FORESTDALE MFG. CO; \$300,000; E. Chas. (C Francis, pres; Chas. E. Thomas, treas, and agt.; Alphonso F. White, supt.; Sheetings, Shirtings and Drills; 7,200 ring and 9,384 mule spindles; 375 looms; water and steam; sell direct; Chas. E. Thomas, buyer.

PITTS, JAMES & SON. See Millville,

**Georgiaville.** B-II. N. Y, N. Cen. Div.

- BERNON MILLS;** \$125,000; J. W. Daniel, (C son, pres.; R. W. Taft, treas.; A. E. Bosworth, supt.; Print Cloths, Plain Sheet- ing and Twills; 14,168 ring spindles; 641 looms; steam and water; sell direct; R. W. Taft, buyer.
- Glendale.** A-10. N. Y, N. H. & H. RR, B & P. Line.
- GLENDALE WOOLEN MILL;** William Or- (W) rell, prop.; Fred W. Orrell, supt.; Woolens for Men's Wear; 8 sets; 54 looms; steam and water; dye; sell direct; Wm. Orrell, buyer. (Buy 2/20 and 2/22 worsted and 12s/4 and 24/2 cotton yarn.)
- Graniteville,** see Harrisville and Pascoag.
- Greenville.** B.H. Stage at Centredale, on N. Y, N. H. & H. RR, Cen. Div.
- ELITE MFG. CO;** \$50,000; Daniel F. Treacy, (C pres.; Jas. Ashworth, treas. and supt; C. W. Nass, agt. and buyer; Cotton Finishes; 3,000 ring and 3,500 mule spindles; 33 looms; steam and water; sell direct. (Office, 225-227 Banigan Bldg., Prov.)
- GREENVILLE WOOLEN MILLS;** R. T. (W) Waterhouse, treas; R. Waterhouse, agt; J. H. Waterhouse, supt; Worsteds and Woolens; 4 sets; 40 looms; steam and water; dye; Jas. Talcoff, N. Y, s. agt; R. T. and J. H. Waterhouse, buyers.
- Hamilton.** D.H. Station at Wiekford on N. & W. RR.
- HAMILTON WEB CO;** \$150,000; James A. (C) Greene, pres. and treas; J. W. Greene, supt; Cotton Worsteds and Silk Narrow Fabrics, Tapes, Strappings; also Colored Yarns for Worsteds Trade; 4400 spindles; 107 looms; water and steam; dye; sell direct. J. W. Greene, buyer.
- Harris.** See Phoenix.
- Harrisville.** A-10. N. Y, N. H. & H. R. R., Cen. Div.
- ANCHOR MILLS;** (American Woolen (W) Co.); Finishing only; steam and water; dye. Merged with Pascoag plant, and other machinery removed there. See Pascoag.
- GLEN WORSTED MILLS;** \$30,000; E. F. (W) Lovejoy, (Pascoag) pres; E. F. Arnold, (Prov.) treas; P. A. Schwartz, supt; Worsteds and Cottons; 31 looms; water and steam; sell direct and Whitman & Phelps, N. Y., s. agts; E. F. Arnold, buyer. (Buy 12/4 to 40/2 cotton and 12/2 and 50/2 worsted yarns.)
- ROYAL WORSTED MILLS;** \$80,000; Wm. (W) Loebel (N. Y.) and William and Ernest Tinkham (Harrisville), interested. Proposed.
- TINKHAM, WM. & Co;** Harrisville Mill; (W) E. W. Tinkham, supt. and buyer; Fancy Worsteds; 75 looms; steam and water; dye; sell direct; buy worsted and cotton yarns.
- Hill's Grove.** C.H. N. Y, N. H. & H. RR, Ston. Div.
- ELIZABETH MILL CO;** \$300,000; Wm. C. (C) Pierce, pres; Wm. G. James, treas. agt. and supt; Thread Yarns; 24,000 spindles; steam; sell direct. Also Mill No 2 at E. Greenwich
- Hope.** C.H. N. Y, & N. H. & H. RR, Pawtuxet Valley Br.
- HOPE CO;** \$200,000; R. H. J. Goddard, (C) treas; Goddard Bros. (Prov.) agts; R. G. Browland, supt; Shirtings; 19,744 ring and 24,896 mule spindles; 881 looms; water and steam; Moss, Taylor & Co, N. Y, s. agts.
- Hope Valley.** D-10. Wood River Br. RR, EDWARDS, L; see Canonchet. (C)
- TAYLOR MFG. CO.;** (leased Hope Valley (W) Woolen Mill); (F. S. Taylor, C. S. Taylor and G. M. Youngman, partners); Clair S. Taylor, gen'l mgr.; Woolen Overcoatings, Suitings, Cloakings and Skirtings; 4 sets; 62 looms; steam and water; dye; Stevens, Sanford & Handy, N. Y., s. agts.; F. S. Taylor (Charlton, Mass.), buyer. (Buy cotton warps No. 18.)
- NICHOLS & LANGWORTHY MACHINE CO;** (C) Loenstville Mill; A. G. Nichols, pres; H. C. Nichols, treas; Geo. H. Nichols, supt; 56x56 Print Cloths; 5650 spindles; 114 looms; steam and water; sell direct. Closed indefinitely.
- Kenyon.** E-10. N. Y, N. H. & H. RR, Ston. Div.
- KENYON, E. & SON;** J. S. Kenyon, buyer; (W) Cloakings and Cassimeres; 9 sets; 43 looms; water and steam; dye; Faulkner, Page & Co., N. Y, s. agts.
- Lafayette.** D.H. Station Wiekford June- N. Y, N. H. & H. RR, Ston. Div.
- RODMAN MFG. CO;** Lafayette Mill; (W) \$500,000; Albert Rodman, pres; Walter Rodman, treas; Franklin Rodman, supt; Doeskins and Jeans; 16 sets; 290 looms; water and steam; dye; P. Van Volkenburgh & Co, N. Y, s. agts.
- RODMAN MFG. CO;** Wakefield Mill; Al- (W) bert Rodman, pres; Walter Rodman, treas; B. M. Wilcox, supt; Doeskins and Jeans; 4 sets; 72 looms; water and steam; dye; P. Van Volkenburgh, N. Y, s. agt. Mills at Wakefield and North Kingston. See Allenton.
- Lonsdale.** B.H. N. Y, N. H. & H. RR, Wor. Div.
- LONSDALE CO;** \$1,000,000; Robert H. God- (C) dard, pres; Wm. Goddard, treas; Goddard Bros. (Prov.) agts; E. A. Mongeon, supt; Fine Bleached Sheetings, Silesias, Hollands, etc; 178,441 spindles; 4,163 looms; water and steam; dye; also bleach; Moss, Taylor & Co, N. Y., Wheelwright Eldredge Co., Boston and Converse Stanton Co., Boston, s. agts; agents and superintendent, buyers. (Also Ashton.)
- Lymansville.** B.H. N. Y. & N. E. RR, Cen. Div.
- LYMANVILLE CO;** \$500,000; A. Albert (W) Sack, pres. and treas; Herman Ambach, supt; Worsteds Suitings and Yarns; 20 sets; 11 combs; 100 looms; water and steam; dye; sell direct, 87 Worth St, N. Y.
- Manton.** B.H. N. Y, N. H. & H. RR, Cen. Div. and electric cars from Prov.
- MANTON MILLS;** (American Woolen Co.) (W) Wm. M. Wood, (Boston), treas; Edmond Coreoran, agt; Worsteds; 11 sets; 189 looms; steam and water; dye; J. Clifford Woodhull, N. Y., s. agt.
- MINTO, JAMES D.;** Dyer and Spooler of (D) Cotton and Worsteds Yarns; 14 dyeing, 20 winding, 20 spooling machines; (capacity of 10,000 lbs. daily).
- Mauville.** A-H. N. Y, N. H. & H. RR, Wor. Div.
- CONTRXVILLE MFG CO;** \$100,000; (C & W) E. R. Handy, pres. and supt.; T. H. Handy, treas. and agt.; Flashes; 130 looms; steam; dye; sell direct; E. R. Handy, buyer.
- MANVILLE CO;** H. F. Lippit, treas. and (C) agt.; A. Tenny White, supt; Fancy Cottons; 45,000 ring and 50,000 mule spindles; 3600 looms; steam and water. (See Woonsocket.)
- Mapleville.** A-10. See Oakland.
- Mohegan.** A-10. R. R. Station, Nasonville, N. Y, N. H. & H. RR.
- WANSKUCK CO;** Mohegan Mills; (P. O. (W) address, Nasonville, R. 1.) W. H. White, buyer and supt; Clay Worsteds; 60 looms; water; dye. (Branch of mill at Providence.)
- Nasonville.** A-10. N. Y, N. H. & H. RR, B. & P. Line.
- NASONVILLE WOOLEN CO;** \$60,000; Eli (W) Gilboa, pres. and treas; Woolens and

- Worsted; 5 sets; 41 looms; water and steam.
- OAK VALLEY WOOLEN CO.** See Tarklin. (**W**)
- Natick.** C. H. N. Y., N. H. & H. RR, Taunton & Cent. Divs.
- NATICK MILLS;** B. B. & R. Knight (Prov.); (**C**) Robt. Knight, treas.; Chas. M. Holmes, supt.; Sheefings and Shirts; 59,908 ring 41.120 mule spindles; 3000 looms; water and steam; sell direct; Wm. O'Neill, buyer.
- Newport.** D-12. N. Y., N. H. & H. RR, Taunton Div.; Newport & Wickford Steamboat Co.
- NARRAGANSETT WEB CO.** *Out of business.* (Plant bought by Am. Tubing and Webbing Co., Providence.)
- Nooseneck Hill.** D-30. RR, Station Washington, N. Y., N. H. & H. RR, Cent. Div.
- TINGLEY, GEO. S.;** (P. O. Box 1475 Prov.); (**C**) Geo. W. Edwards, supt.; Twine, Carpet Yarn, Sash and Trolley Cord and Braided Clothes Lines; 2500 spindles; 60 braiders; steam and water; sell direct; G. S. Tingley, buyer.
- No. Providence.** B-II Manton on N. Y., N. H. & H. RR, Cen. Div.
- ALLENDALE CO;** \$90,000; (P. O. address, (**C**) Prov.); Wm. D. Ely (Prov.), pres. and treas.; Geo. W. Gould, mgr; Wide Cotton Sheefings, Quilts, etc.; 468 and 552 mule spindles; 204 looms; steam and water; Fred'k Victor & Achelis, N. Y. s. agts; Geo. W. Gould, buyer.
- No. Scituate.** B-10. Stage at Prov, N. Y., N. H. & H. RR.
- No. SCITUATE COTTON MILLS;** \$100,000; (**C**) pres.; Robert F. Adams, treas. and agt.; Geo. H. Bartlett, supt.; Crinolines, Nets, Linings, etc; 10,048 spindles; 108 wide and 54 narrow looms; water and steam; R. F. Adams, s. agt. and buyer. (N. Y. office 13 Walker St.)
- No. Smithfield.** A-11. Ry. station, Smithfield. N. Y., N. H. & H. RR.
- PITTS, JAMES, & SON.** See Millville, Mass. (**W**)
- Norwood.** C-H. (Not shown on map.) N. Y., N. H. & H. RR.
- WHITING, JOHN C.;** Cotton, Woolen, Silk (**C**) and Mohair Braids; 200 braiders; steam; sell direct. (Formerly at Providence.)
- Oakland.** A-10. Pawcatuck RR.
- CORONET WORSTED CO.;** J. E. Fletcher, (**W**) pres. and treas.; John H. Lloyd, supt.; Fancy Worsteds; 7 sets; 151 looms; steam and water; dye; sell direct. 377 B'way, N. Y.; Joseph E. Fletcher, buyer. (Buy worsted yarn from 20/2 to 50/2 and cotton 20/2 to 40/2.)
- HOPE WORSTED MILLS** (mill at Burrills—(**W**) ville); Frank Fiske, agt.; Arthur Ames, supt.; Men's Wear Worsteds; 22 looms; steam and water; dye; sell direct. (Freight address, Whipple Station.) (Operating plant of Dunkirk Worsted Mills.)
- OAKLAND WORSTED CO.;** J. H. Metcalf, (**W**) pres.; S. O. Metcalf (Prov.), treas.; W. H. White, supt.; Worsteds; 82 looms; steam and water; dye; Metcalf Bros. & Co, N. Y., s. agts
- Olneyville.** B-II. N. Y., N. H. & H. RR, Cen. Div. *See also Providence.*
- ATLANTIC MILLS;** see Providence.
- BRITISH HOSIERY CO.;** (P. O. address, (**K**) Thornton); \$200,000; Fritz Achelis, pres.; Geo. E. Boyden, treas.; Rodolph Berry, sec.; 8 Silks, supt. and buyer, Fine Full-Fashioned Cashmere and Cotton Hosiery; 3 sets; 3 combs; (Bradford system); 1856 spindles; 104 knitting machines; water and steam; dye; E. F. Boyden, Room 307 N. Y. Life Bldg., N. Y. s. agt. (Buy cotton yarns, 9s to 50s.)
- EARNLIFFE WORSTED MILL;** Guile & (**W**) Waterhouse, props; Fine Worsteds; (buy worsted yarns); 113 looms; steam; dye; sell direct.
- Pascoag.** A-10. N. Y., N. H. & H. RR, Cen. Div.
- ANCHOR MILLS;** (American Woolen Co.) (**W**) Wm. M. Wood, (Boston), treas.; William A. Inman, res. agt.; Worsteds Suitings and Trousering; 2 sets; 174 looms; water and steam; J. Clifford Woodhull, N. Y., s. agt.
- DUSTIN, J. F. MFG. CO.;** Corduroys and (**C**) Velvetens for Men's and Ladies' Wear and Plushes and Corduroys for Upholstery Trade.
- GLEN WORSTED MILL;** F. F. Arnold, agt. See Harrisville.
- LAUREL HILL YARN CO.** (See Bridgeton.)
- SAYLES, A. L. & SONS;** Granite Mills; (**W**) H. A. Waterhouse, supt.; Woolens and Worsteds for Men's Wear; 16 sets; 108 looms; steam and water; dye; Jacob Wendell & Co., Boston and N. Y., and H. W. T. Mali & Co., s. agts.
- SAYLES, FRED. L. CO.;** \$60,000; A. H. (**W**) Sayles, pres.; Fred L. Sayles, treas. and agt.; John S. Walling, supt.; Cotton Worsteds; 6 sets; 101 looms; water and steam; dye; sell direct and W. Stursberg, Schell & Co., s. agts; Fred L. Sayles, buyer. (Buy 2/40 worsted, 2/30 cotton yarns.)
- STONE WORSTED MILL;** Samuel Mellor, (**W**) prop; Fancy Worsteds for Men's Wear; 3 sets; 34 looms; water and steam; sell direct and Harldt Von Bernuth & Co, 79 Worth St, N. Y., s. agts. *Burned April, 1902.*
- Pawtucket.** B-II. N. Y., N. H. & H. RR, Wor. & Prov. Div.
- ADAMS, JOHN F.;** See Adamsdale, Mass.
- AMERICAN HAIR CLOTH CO.;** \$450,000; E. N. (**C**) Littlefield, pres.; Henry B. Metcalf, treas.; Chas. E. Pervear, agt.; Hair Cloth and Fibre Cloth; water, steam and electricity; dye; sell direct; Chas. E. Pervear, buyer. (Buy 1/16, 2/30, 2/38 on loom beams.)
- AMERICAN TEXTILE CO.;** \$300,000; Geo. M. (**C**) Thornton, treas.; Chas. W. Shepard, mgr; Wm. H. Smith, supt.; Cotton and Silk Laces; steam; sell direct; Chas. W. Shepard, buyer. (Buy 12/2 to 250/2 cotton, Combed Egyptian and Sea Island, all numbers silk.)
- AM. YARN MFG. CO.;** \$200,000; Geo. M. (**C**) Thornton, treas.; L. M. Smith, agt, supt. and buyer; Sateens; 11,592 ring and 12,360 mule spindles; 384 looms; steam; sell direct.
- BLACKSTONE STOCKING CO.;** A. H. Smith, (**K**) prop; Men's, Women's and Childrens' Cotton, Cashmere and Merino Hosiery; 150 knitting machines; steam; dye; sell direct; A. H. Smith, buyer. (Buy cotton yarn, 10 to 30 single; worsted, 18 to 60 single.)
- BLACKSTONE BRAID CO.;** \$6,000; Geo. C. (**C**) Carpenter, pres.; Geo. A. Miller, treas.; Cotton Shoe Lacings; 118 braiding machines; water; Geo. A. Miller, 88 Lincoln St., Boston, s. agt.
- BLODGETT & ORSWELL CO.;** \$100,000; E. (**C**) W. Orswell, pres. and treas.; W. W. Orswell, sec; W. G. Lathan, supt.; Fine Glazed Yarns and Spool Cotton; steam; sell direct.
- BRIGGS, H. A. & Co.;** 248 Pine St; Cot- (**C**) ton Waste Dealers; Cotton Banding and Ropes; sell direct; H. A. Briggs, buyer. (Buy warps, 14/1, beam yarns, 16/1.)
- CHASE & PIGEON.;** 9 Timothy St; Misses' (**K**) Cotton and Worsted Ribbed Hosiery; 8 knitting machines; (buy yarn); dye; sell direct.
- COLLYER INSULATED WIRE CO.;** \$100,000; (**C**) Frank J. Dutcher, pres.; C. H. Bowen, treas. and buyer; F. J. Conboy, supt.; Insulated Electric Wires and Cables; 152 braiders; N;

- steam; sell direct. (Buy 8/4 ply, 8/3, 8/2, 10/1, 12/1, 12/2, 20/2, 26/2 yarns.)
- CONANT THREAD CO.;** J. & P. Coats, Ltd.; (C) \$2,000,000; Jas. Coats, pres.; Jos. Belfield, supt.; Spool Cotton; about 125,000 spindles; steam; dye; The Spool Cotton Co., N. Y., s. agts.
- CUMBERLAND MILLS CO.;** see Valley (C) Falls.
- DEMPESEY BLEACHERY & DYE (B I D & F** Works; \$100,000; Wm. P. Dempsey, pres. and treas.; Wm. H. McDermott, supt.; Bleachers, Dyers and Finishers of Cotton Piece Goods; steam; treas. and supt., buyers.
- DEXTER YARN CO.;** 86 East Ave.; \$200,000; (C) S. Willard Thayer, treas.; Byron L. Waterman, sec.; Combed and Carded Hosiery Yarn, in Cops, Skeins, Cones, Twisted Yarns and Yarns on Beams, for Weaving Trade, Knitting Cotton; 1,920 ring and 8,128 mule spindles; water and steam; sell direct; B. L. Waterman, buyer.
- DOUGLAS, G. C.** *Out of business.*
- DUNNELL BRANCH.;** (U. S. Finishing (P R Co., N. Y.); Geo. Barr, res. mgr.; F. B. Hodges, supt.; Finishers Cotton Piece Goods; 13 machines. (See New York City for officers, etc.)
- EAGLE DYE WORKS.;** Newton Earle, (D) agt.; Cotton Dyeing and Carding; 120 cards; 16,000 lbs. per day; steam; Newton Earle, s. agt.
- ETCHELLS, Wm. G.;** Fancy Shirtings; 20 (C) looms.
- EVERLY, D. A.;** 28 Baily St.; Fancy Dress (C) Goods; 40 looms; steam; sell direct. (Buy cotton and linen yarn, 40, 50, to 80, single and 2 ply.) (In Campbell Bldg.)
- FLOSSETTE MFG. CO.;** H. A. and F. E. (S) Warburton, props; Fred'k Jackson, supt.; Flossette for Crocheting, Knitting and Embroidering, Flossine (silk imitation) for Sewing, also Thread Specialties; 28 spool and 4 ball cotton winders; 11 dressers; 5 spoolers; 3 twisters; 2 ballers; 3 reelers; 20 universal tube and cones; steam; sell direct and Alfred Fawcett, N. Y. s. agt.; F. E. Warburton, buyer.
- FRENCH HAIR CLOTH CO. THE.;** John M. (C) Campbell, pres.; Wm. P. Dempsey, treas.; Harry S. Jordan, agt. and buyer; Hair Cloth; 104 looms; steam; sell direct. (Buy 16/1, 30/2, 40/2 yarn.)
- GOFF, D. & SONS.;** \$600,000; D. L. Goff, (C & W) pres. and treas.; J. A. Perry, mgr. and supt.; Skirt Braids, Mohair Car Plushes and Linings; Worsted and Mohair Yarns; 9,728 worsted spindles; 8 combs (Bradford system); 3 worsted cards; 287 looms; water; sell direct; plushes through C. M. Aikman & Co., N. Y.; J. A. Perry, buyer.
- GREEN MOUNTAIN BRAIDING CO. (office (C** 16 High St.); factory, Old Slater Mill; \$50,000; Louis E. Alden, pres.; Charles W. Davis, treas.; Chas. E. Alden, supt.; Shoe Laces; 133 braiders; water; sell direct; Chas. W. Davis, buyer. (To double capacity of plant.)
- GREENE & DANIELS MFG. CO.;** \$275,000; (C & D) Mrs. A. H. Greene, pres.; Wm. H. Greene, treas.; Henry C. Dexter, agt.; Alfred L. Clark, supt.; Thread, Yarns and Twines; 23,184 ring and 774 mule spindles; steam; dye; sell direct; Alfred L. Clark, buyer.
- HARRISON YARN & DYEING Co. Rich. (C & D** and Harrison, pres. and treas.; Dyers and Finishers of Yarns; 4000 per day; Winding Machinery; sell direct.
- HILL, WILLIAM.;** (Old Slater Mill); Baby (C) Carriage Robes, Shawls, Dress Goods, Towels, Webbing, Tapes, Etc.; 10 looms; 2 sewing machines; water.
- HOME BLEACH & DYE WORKS.;** Peter (D & B I) B. McManus, prop.; Dyers and Bleachers of Cotton Yarn in Skein and Warp and Spool Threads; Tapes, Braids, Etc., also Mercerizers; Edward J. McCaughey, buyer.
- HOPE WEBBING CO.;** 1005 Main St.; (C & S) \$300,000; Chas. Sisson, treas.; Oscar A. Steere, supt.; Narrow Woven Fabrics; 425 looms; steam; sell direct; W. C. Shorman, yarn buyer. (Buy 8s to 120s.) Office in Providence.
- INVINCIBLE KNITTING CO.;** 37 Bayley (K) St.; F. N. Blake, agt.; George E. Moore, supt.; Men's, Women's and Children's Circular Hosiery; 10 knitting machines; steam; Wm. Iselin & Co., s. agts.
- JENCKES, E. MFG. Co.;** \$400,000; (C) Stephen A. Jenks, pres.; J. E. Jenckes, treas.; F. L. Jenckes, agt.; Wm. P. Wood, supt.; Colored Cotton Yarns in Solids, Mixtures and Combinations; 40,000 mule spindles; steam; dye; sell direct; F. L. Jencks, buyer.
- KENYON, JOHN J. MFG. CO.;** \$100,000; John (C) J. Kenyon, pres. treas. and buyer; Robt. A. Kenyon, supt.; John F. Kenyon, sec.; Braids, Tapes, Shoe and Corset Lacings, Glazed Yarns, Spool Cotton; 1100 braiders; 60 looms; 24 dressing machines; steam; sell direct. (Buy cotton yarn, 12 to 40 single, 12 to 50 2 ply.)
- LEBANON MILL CO.;** (P. O. Box 676); (K) S. W. Thayer, pres. and supt.; A. Thayer, treas. and agt.; Rubber Linings, Knitted Fabrics of all kinds and Underwear; 80 knitting machines; steam; sell Rubber Linings direct; Knitting Mills Trading Co. for Underwear. (Buy cotton yarn 9 to 65 single, worsted 45 to 70 single.)
- LITTLEFIELD MFG. CO.;** \$150,000; A. H. (C) Littlefield, pres.; E. N. Littlefield, treas.; Yarns; 8,400 spindles; steam and water; sell direct.
- LORRAINE MFG. CO.;** \$1,250,000; F. A. (C & W) Sayles, pres.; J. R. MacColl, treas.; Cotton and Worsted Dress Goods, Shirtings, Etc.; 12,000 worsted and 40,000 cotton spindles; 13 combs; 1750 looms; steam; Lorraine Mfg. Co., 53 Leonard St, N. Y., s. agts. (Branch mill at Westerly, R. I.)
- LUMB, Geo. H.;** E. P. Sheridan, supt.; (K) Ladies' and Infants' Ribbed Underwear, Knit Corset Covers; 30 knitting machines; 60 sewing machines; sell direct and Critten, Clift & Co., N. Y., s. agts. (Buy 20 to 50 combed Peeler and 30 to 50 worsted yarn.)
- MASON, ROBT. D. CO. THE.;** \$100,000; (D & B I) Frederic R. Mason, pres. and treas.; Wm. J. Burton, supt.; Dyers and Bleachers of Thread, Stockinet, Braids, Yarns, Etc.
- NARRAGANSETT KNITTING CO.;** Men's (K) Fashioned Ribbed Underwear; 8 knitting machines; steam; Fleitmann & Co., N. Y., s. agts.
- NEW ENGLAND THREAD CO.;** (C, D & B I) \$100,000; H. A. Warburton, Sr, prop; H. A. Warburton, Jr, gen. mgr; F. H. Grover, supt; All Kinds Spool Cotton and Super fine Tapes, 19 dressers; 68 winders; 2 combers; 10 tubers; 1 coner; 7 spoolers; 16 tape looms; steam; dye and bleach; sell direct; H. A. Warburton, Jr., buyer. (Buy cotton yarn, 8 to 100, 2, 3, 4, 6 ply.)
- ORK BROS.;** Dyers of Worsted Braid (D & F) and Yarns, Plushes, etc; steam.
- PAWTUCKET BRAIDED LINE CO.;** A. (C & S) G. Hazard, prop.; Fishing and Chalk Lines, Shoe Lacings and Braided Corks; sell direct. (Buy cotton lining and silk from 4 to 100 single, 2 ply up to 9 ply.)
- PAWTUCKET DYEING & BLEACHING (D & B I** Co.; \$100,000; Wm. Rapp, pres.; E. W. Orswell, treas.; Dyers and Bleachers of Yarns, Warps, Stockinet; office with the Blodgett & Orswell Co.



- PAWTUCKET TAPE CO;** (office at Providence); John F. Street, pres; Chas. F. Eddy, treas.; J. J. Kenyon, agt. and supt.; Superfine and Common Tape; 38 looms; steam; sell direct. (Buy 20 and 30 yards.)
- PHILLIPS INSULATED WIRE CO;** \$250,000; (C) H. C. Adams, pres; H. O. Phillips, treas.; E. B. Phillips, supt.; Insulated Wires; 900 braiders; steam; buy yarn.
- RHODE ISLAND ELECTRICAL WORKS;** (C) \$125,000; Chas. D. Wood, treas.; A. E. Montgomery, mgr; Magnet Wire; 750 machines; steam; sell direct. (Buy 100s cotton, also tram silk.)
- ROYAL WEAVING CO;** \$600,000; D. (C, W & S) L. Goff, pres; Chas. E. Pervear, treas.; Joseph Ott, agt; Fine Grades of Cotton, Worsted, Silk and Velvet Fabrics; 860 looms; steam; dye; sell direct; J. Ott, buyer.
- SLATER COTTON CO;** \$360,000; F. A. Sayles, (C) pres, C. E. Lindsey, treas. and agt; V. T. Barber, supt; Fine Cotton Goods, Lawns, Cambries, etc; 26,640 ring and 28,884 mule spinates; 1365 looms; steam; Treat & Converse, N. Y., Boston and Phila., and Clarence Whitman & Co, N. Y., s. agts; V. T. Barber, buyer.
- SMITH, AMSDEN H. Co.;** Rear 51 N. Main (D) SL; Coloring only on Cotton and Worsted Yarns and Hosiery; sell direct.
- SMITH WEBBING CO;** \$100,000; W. A. (C) Walton, pres; E. H. Parsons, treas; Chas. S. Smith, manager; Frank J. Gramelsbach, supt; Narrow Elastic and Non Elastic Narrow Fabrics; 75 looms; steam; sell direct; Chas. S. Smith, buyer. (Buy Southern yarns, 26/2, 24/2, 20/2, 26/3; Eastern, 40/2, 60/2, 80/2, 26/2, 40/2; Mer. 26/2, 10/2)
- STAFFORD MFG. Co.** see Central Falls.
- UNION WADDING CO;** \$1,000,000; L. B. (C) Goff, pres; Geo. M. Thornton, treas; H. A. Stearns, supt; Wadding and Bating; 300 cards; N. Y. office 49 Leonard St.
- U. S. COTTON CO;** see Central Falls.
- U. S. KNITTING CO;** Geo. L. Miller, (K) treas; Knit Goods; 30 knitting machines; sell direct; steam; G. L. Miller, buyer.
- WILKINSON, SETH;** Silk Wiping Cloths; 2 (S) sets; 8 looms; 360 spindles; steam; sell direct.
- Peace Dale.** E-II. Narr. Pier RR.
- DALECARLID WORSTED MILL;** Edward (W) and John Doane; Fancy Worsteds; 6 looms; steam. (Buy yarns 2/88 to 2/40s.)
- PEACE DALE MFG. CO;** \$500,000; R. G. (W) Hazard, pres; W. C. Greene, treas; Jas. W. Drysdale, supt; Shawls, Cashmeres, Overcoatings, Worsteds Coatings, Worsteds Serges; 7 combs; 12 sets; 160 looms; steam and water; dye; Lawrie, Mann & Drowne, N. Y., s. agts; W. C. Greene, buyer.
- Phenix.** C-II. N. Y. N. H. & H. Sten. Div.
- INTERLAKEN MILLS (Harris Mill);** A. L. (C) Ordway, pres.; Edward C. Bucklin, treas.; R. W. Andrews, supt.; Book Cloths; 10,960 ring and 15,360 mule spindles; 490 looms; water and steam; dye; sell direct; R. W. Andrews and E. C. Bucklin, buyers. (Buy No. 30 warp.) (See also Arkwright.)
- LIPPIT MILL, B. B. & R. Knight (Prov.);** (C) M. C. Latham, supt.; Twills and Sheetings; 9488 spindles; 231 looms; water and steam; sell direct.
- A. & M. SPECIALTY MFG. CO;** \$50,000; (C) A. H. Sawtelle, pres. and supt.; A. H. Ladd, treas.; Pads, Serviettes, Etc.; 10 looms; water and steam; sell direct; A. H. Sawtelle, buyer. (Buy No. 28 cotton yarn)
- Pontiac.** C-II. N. Y. N. H. & H. RR. Sten. Div. & Cent. Div.
- PONTIAC BLEACHERY;** Pontiac Mfg. Co; (B) R. Knight, pres. and treas; Bleaching; 25 tons per day; water and steam.
- PONTIAC MFG. CO;** R. Knight, pres. and (C) treas; Fine Sheetings and Odd Goods; 30,000 spindles; 542 40 in. and 140 10/4 looms; water and steam; sell direct; Wm. O'Neill (Prov.), buyer.
- Potter Hill.** E-9. Station at Westerly on N. Y. N. H. & H. RR. Sten. Div.
- CAMPBELL MILLS;** Est. J. P. Campbell; (W) J. M. Scott, trustee; 11 sets; 56 looms; steam and water; dye. *Not running.*
- Providence.** B-II. N. Y. N. H. & H. Prov. Ply. Divs. *See also Obnegrille.*
- ALLEN'S PRINT WORKS;** Operated by (Pr) Am. Linen Co. and Merchants Mfg. Co. (Fall River, Mass.)
- AM. ELECTRICAL WORKS;** \$500,000; E. F. (C) Phillips, mgr; Gas Tubing and Insulated Wire; 7500 braider carriers; 392 winder heads; steam; dye; P. C. Ackerman, N. Y., F. C. Donohoe, Chicago, s. agts. (Office, 49 Westminster St.)
- AMERICAN MULTIPLE FABRIC CO;** \$200,000; (C) Chas. Fletcher, pres; W. A. Wilkinson, treas; A. A. Wilkinson, agt. and supt; Patent Multiple Woven Fabrics; 576 spindles; 40 looms; steam; sell through agents and direct.
- AMERICAN SHOE LACE CO.;** Armington (C) Simms Bldg.
- AM. TUBING & WEBBING CO;** Gordon (C & S) Ave; \$276,000; Alfred Caldwell, pres. and gen. mgr; G. M. Thurlow, treas; Elastic Webbing for Suspenders and Garters, Hat Elastics, Braids and Cords, Silk and Cotton; 1000 braiders; 175 looms; steam; Dresser & Co., N. Y., s. agts.; Alfred Caldwell, buyer. (Buy 12/2 up to 90/2 in Southern cones, gassed yarn and mercerized yarns.)
- ATLANTIC MFG. CO;** 39 Stewart St; (C) \$100,000; Eugene F. Phillips, pres; Frank N. Phillips, treas; Henry H. Sherman supt; Tubing of All Kinds, Special Sizes Made to order; 1808 spindles; steam; sell direct; American Electrical Works, buyer.
- ATLANTIC MILLS;** \$1,500,000; C. D. (W) Owen, pres; Theophilus King (Boston), treas; Chas. P. Owen, agt; Thomas B. Owen, supt; Worsteds Dress Goods; 65 combs; 21,320 cotton spindles and 41,000 worsted spindles; 2554 looms; steam; dye; A. D. Juilliard & Co, N. Y., s. agts.
- BALLOU YARN CO;** 189 Charles St; \$50,000; (C) Edward R. Bailon, treas; Gassed Yarns and other Specialties; sell direct.
- BARSTOW THREAD CO.** (Renovated to Polygok Mass.) Plant purchased by Queen Dyeing Co.)
- BERKELEY CO.** See Berkeley.
- BLANDING, C. L. MFG. CO;** office 48 Ex- (W) change Pl. (Prov.); C. L. Blanding, mgr. and buyer; Wool, Wool Waste, Shoddy, Noils and Garnetting Stock, Scurers Carbonizers; 54 cards; 12 garnetting machines; 4 pickers; 1 burr picker; dye; steam; sell direct.
- BROWN, Wm. E.;** 351 Weybosset St; Elastic (K) Stockings, Knit Caps; Surgical Bandages; etc; 4 knitting machines; 2 sewing machines; sell direct. (Buy cotton yarns 60/2 silk tram and skein, worsted 28/2, silkline 60/2.)
- COLUMBIA NARROW FABRIC CO.** Renovated to Shannock, R. I., which see.
- COLWELL, R. & Co;** 9 Callendar St; John (W) Broadbent, supt; Worsted Dress Goods; 40 looms; steam; sell direct; R. Colwell, buyer. (Buy 2/32s and 2/28s worsted, 1/4 blood stock.)
- CROWN CARPET LINING CO;** 456 Potts (C) Ave.; \$25,000; Wm. A. Mauran, sec; Howland L. Perkins, treas; Wm. A. Mauran, Jr, supt; Woven Tissue Paper Carpet Lining; 15 looms. (Buy 12, 40-2 and 40-3 yarn.)

**CROWN WORSTED MILLS;** Greaves & (W) Hutchinson, props; Troy & Oak Sts; Alfred J. Greaves, supt.; Fine Worsted Yarns; 402 worsted spindles (Bradford system); steam; sell direct; both, buyers.

**DAVIS, HENRY A. & SONS;** 143 Summer (W) St; Shoddy and Carbonizers; 9 garnett machines; steam.

**DIYERVILLE MFG. CO;** 610 Manton Ave; (C) \$250,000; Truman Beckwith, treas; G. W. Robbins, supt.; Sheetings, Lawns and Satens 15,000 spindles; 419 looms; water and steam; G. W. Robbins, buyer.

**ELMWOOD MILLS** \$300,000; Arthur W. (C) Dennis, pres, treas. and buyer; Walter H. Morse, supt.; Shoe Laces, etc; 2000 braiders; steam; sell direct. Consolidation of Elmwood Mills, Elmwood Braid Co. and Wm. E. Joslin Co. Mill at Elmwood.

**FITCH, SAM'L, MFG. CO;** Jesse (K, B) & D P. Eddy, Jr, pres.; F. W. Perkins, treas., supt. and buyer; Elderdowns Fleece Linings and Cottonettes; 22 knitting machines; steam; sell direct; also Dyers and Bleachers of Worsted, Woolen, Cotton Yarns and Raw Stock. (Mills at Thornton.)

**FLETCHER MFG. CO;** \$300,000; W. B. (C) Fletcher, pres; Wm. Ames, treas. and agt; J. O. Ames, sec. and buyer; Henry Fletcher, agt.; Jos. Drounsfield, supt.; Wicks, Yarns, Braids, Boot, Shoe and Corset Laces; 30,000 ring spindles; steam; dye; sell direct. (Buy some fine spun 60s and above.)

**GENEVA MILL;** Wamskuek Co; John (W) H. Neff, supt.; Woolen and Worsted Men's Wear; 5 sets; 87 looms; steam and water; dye; Metcalf Bros. & Co. 39 Worth St, N. Y., s. agts. (Also at Mohegan.)

**GLENLYON DYE WORKS;** Phil. (B) & Pr Upsdale Branch; E. R. Blanchard, mgr.; A. L. Lustig, supt.; Bleaching, Dyeing, Printing and Finishing of Fine Silk or Silk and Cotton Fabrics, and Fine Light Cottons; steam; E. E. Dodge, buyer. See *Saylesville*.

**HEBRON MFG. CO;** Grant Mills; S. A. (C) Knight, pres; Robt. Knight, treas; S. A. Knight, agt; Wm. J. Eastman, supt; Fruit of the Loom Sheetings; 5056 ring and 4608 mule spindles; 302 looms; steam; sell direct. Also Dodgeville and Hebronville, Mass.

**HOPE WEBBING CO.** See Pawtucket.

**JOSLIN MFG. CO;** Merino Mills; \$500,000; (C) W. E. Joslin, pres, and treas; Charles A. Tucker, supt.; Shoe and Corset Laces; 2158 braiders; steam and water; sell direct; H. C. Clemence, buyer. (Also see *Rockland and So. Scituate*.)

**KINSLEY WORSTED CO.** *Out of business.*

**LAWTON SPINNING CO;** Mill No. 1 at OI. (C) neyville; \$900,000; L. R. Peck, pres; W. O. Todd, treas; Wm. Whitman, Jr, supt; Fine Cotton Yarns; 28,176 ring and 29,700 mule spindles; steam and water; Jas. E. Mitchell & Co. s. agts; W. O. Todd, buyer.

**MARCY, HARRY W;** 77 Cromwell St; (C) Shoe Laces and Braids; 150 braiders; sell direct. (Buy yarn.)

**MASON, W. H;** rear 228 Aborn St; (C) Cotton Shoe Laces; 225 braiders; steam; sell direct

**MILLER, ALEXANDER;** Kingsley Ave. and (S) Eagle St.

**NATIONAL ELASTIC WEBBING CO;** 85 (S & C) Sprague St; \$60,000; Chas. H. Perkins, pres; W. C. Perkins, treas; Chas. Godfrey, supt; Silk and Cotton Elastic Webbing; 20 looms; 280 braiders; W. C. Perkins, buyer; N. Y. office, 377 Broadway.

**NATIONAL & PROVIDENCE WORSTED (W) MILLS;** (American Woolen Co.); Wm. M. Wood (Boston), treas; Geo. W. Harris, resident agt; Worsted Yarns - English and

French systems) and Fancy Worsted Suitings and Cloakings; 66 sets; 32 combs; 11,200 woolen and 31,341 worsted spindles; 600 looms; water and steam; dye; J. Clifford Woodhull, N. Y., s. agt.

**NOTTINGHAM MILLS;** B. B. & R. Knight; (C) (formerly Wauregan Mills); John G. McFadden, supt.; Print Cloths and Sheetings; 13,600 ring, 6400 mule spindles; 463 looms; sell direct.

**ORIENTAL MFG. CO;** \$150,000; J. M. Scott, (C) pres.; H. F. Lawton, treas.; A. W. Matteson, supt; Coltons, Twills and Satens; 20,86 spindles; 498 looms; steam; sell direct; A. W. Matteson, buyer. Office 401 and 402 Industrial Trust Co, 49 Westminster St, Prov.

**PARAMOUNT WORSTED MILLS, THE;** (W) Eagle St. and Kingsley Ave.; \$60,000; Leonard Hollingsworth, pres., treas. and agt.; Piece Dyes for Men's Wear; 20 broad looms; steam; dye; sell direct and Earncliffe Worsted Mills, s. agts.; L. C. Hollingsworth, buyer. (Buy all sizes and grades cotton and worsted yarns.)

**PHOENIX SPINNING CO;** 11 West Friend. (W) ship St; \$50,000; P. S. Peckham, Jr, pres. and supt. P. W. Tillinghast, treas; Wool and Merino Yarns; 3 sets; 1840 spindles; steam; sell direct; P. S. Peckham, Jr, buyer.

**PROVIDENCE DYEING, BLEACHING (B) D & F & CALENDERING CO;** \$95,000; Wm. Oscar Cornell, pres; John P. Farnsworth, treas; Herbert S. Burgess, supt.; Bleaching, Dyeing and Finishing Cottons; steam; John P. Farnsworth, buyer.

**PURIFAN WORSTED MILLS;** \$15,000; Geo. (W) Legg, treas.; Wm. Legg, supt.; Clays, Chevots, Worsted and Cotton Mix Worsted; 20 looms; sell direct and through agents. (Buy worsted 1/8 to 1/16 and 2/16 to 2/30 and cotton yarns. 2/12 to 2/26.)

**QUEEN DYEING CO;** W. \$25,000; W. (D & F) Penn Mather, pres; Albert Horton, treas; B. J. Horton, supt; Dyers of Cotton Piece Goods; steam; Albert Horton, buyer.

**REGAL WORSTED MILLS;** 4 Addison (W) Place; J. E. Donley, treas.; John R. Wilson, supt.; Worsted, Mohair and Novelty Yarns (English system); steam.

**RICHMOND MFG. CO.** See Bristol.

**RIVERSIDE MILLS (American Woolen (W) Co.);** Wm. M. Wood (Boston), treas.; Walter Ward, resident agt.; Suitings; 24 worsted cards; 9 woolen sets; 30 combs (English system); 33,912 worsted spindles; 376 looms; steam; dye; J. Clifford Woodhull, N. Y., s. agt.

**SILVER SPRING BLEACHING (B) D P & F & DYEING CO;** 387 Charles St; \$400,000; Charles Nourse Cook, pres.; Chas. W. Lippitt, treas; J. L. Crowell, agt; James D. Lloyd, supt. Bleaching, Dyeing, Printing and Finishing of Cotton Cloth; steam; E. C. Myrick, buyer.

**SIMMONS BRAID CO;** 69 Sprague St; (S, W & C) \$50,000; J. A. Simmons, pres. and treas; Cotton, Worsted and Silk Braids; 1000 braiders; steam; sell direct.

**STEELE WORSTED MILLS;** \$235,000; (W) Stephen O. Metcalf, treas. and agt; W. J. Robinson, supt; Worsted Yarns; 18 combs; 25 sets cards; 10,640 spindles; steam; dye.

**TILLINGHAST, STILES & CO;** 9 Chl. (C & W) lender St; \$100,000; F. W. Tillinghast, pres; G. E. Tillinghast, treas; J. P. Eddy, Jr, asst. treas; Cotton and Worsted Yarn, Colons and Gray, Skeus or Warps, or on Spools, Beams, Cones, etc; 19 winders; 32 spoolers; steam and water; dye; sell direct; office, 49 Westminster St; J. P. Eddy, Jr, buyer.

**VALLEY MILLS;** (American Woolen Co.); (W) Wm. M. Wood (Boston), treas; E. D. Paige, resident agt; Worsted and Mohair Yarns

- died to order in fast colors; 21 sets; 20 combs; 20,000 spindles; steam; dye; J. Clifford Woodhull, N. Y., s. agt.
- VESTA KNITTING MILLS;** \$200,000; R. (K) Berry, pres.; Geo. E. Boyden, treas.; Ladies' and Children's Jersey Ribbed Underwear and Cashmere Hosiery; 6 sets; 285 knitting machines on underwear and 325 machines on hosiery; steam; dye; underwear, W. H. Chamberlin, N. Y.; hosiery, sell direct, 907 New York Life Bldg.; R. Berry and Geo. E. Boyden, buyers. (Buy 20s to 90s Worsted and 8s to 80s cotton yarns.)
- WADSWORTH BRAIDING CO.;** 456 Potter (C) Ave.; C. Edward Blake, treas.; Glazed Yarns and Shoe Lacinings.
- WANSKICK CO.;** \$500,000; S. O. Metcalf, (W) treas.; J. H. Metcalf, agt.; Worsted Cloakings and Coatings; 27 sets; 20 worsted cards; 14 combs; 12,000 worsted spindles; 310 looms; steam; dye; Metcalf Bros. & Co., N. Y., s. agts. See *Geneca mill, Prov. and branch mill at Mohegan.*
- WATERHOUSE, JOHN;** 47 Borden St.; Fine (W) Shoddies and Extracts; 16 cards; 3 pickers, steam.
- WEEDEN MFG. CO., THE** (formerly Geo. E. (C) Weeden); 620 Branch Ave.; \$3,000; Geo. E. Weeden, pres. and supt.; Candle Wicking; 500 braiders; electricity; sell direct.
- WEYBOSSET MILLS;** (American Woolen (W) Co.); Wm. M. Wood (Boston), treas.; Wm. B. Weeden, resident agt.; W. W. Weeden, supt.; Fancy Cassimeres and Worsteds; 25 sets; 318 looms; steam; dye; J. Clifford Woodhull, N. Y., s. agt.
- River Point, C-10, N. Y., N. H. & H. RR, Ston. Div.**
- ARCTIC MILLS;** B. B. & R. Knight; A. F. (C) Brackett, supt.; Print Cloths; 20,144 ring and 16,880 mule spindles; 1037 looms; water and steam; sell direct.
- CLYDE BLEACHERY & PRINT (BI & Pr) WORKS;** \$50,000; S. H. Greene & Sons Corp'n. (20 Market Sq., Prov.); \$500,000; Henry L. Greene, pres.; Edward A. Greene, treas.; Robt. Roach, supt.; Bleaching, Finishing and Printing; 10 printing machines; 2 padding machines; steam; and water; Treat & Converse, N. Y., Phila., Boston and Balto., s. agts.
- ROYAL MILLS;** B. B. & R. Knight; A. F. (C) Brackett, supt.; Cambrie Sheetings and Twills; 22,400 ring and 25,500 mule spindles; 1214 looms; water and steam; sell direct.
- VALLEY QUEEN MILL;** B. B. & R. Knight; (C) A. F. Brackett, supt.; Cambrics; 6012 ring and 8192 mule spindles; 400 looms; steam and water; sell direct.
- Rockland, B-10, Station at Hope on N. Y., N. H. & H. RR, Pawtuxet Valley Br.**
- CLAYVILLE CO.;** \$50,000; Wm. E. (D, BI & F) Joslin, pres.; Edwin A. Smith, treas.; John D. Turner, supt.; Bleach, Dye and Finish Yarns, Warps, Braids, etc.
- JOSLIN MFG. CO.;** Rockland Mill; Albert (C) Luther, supt.; Yarns, Shoe and Corset Lacinings; 4,384 ring and 5,248 mule spindles; 220 looms; steam and water; sell direct. *Not running.* (See Main mill at Providence; branch mill at So. Scituate.)
- PONOGANSETT MILL;** Joslin Mfg. Co.; (C) W. Oatley, supt.; Yarns; 4,160 mule and 3,568 ring spindles; water.
- Rockville, D-10, Station Hope Valley on Wood River Br. RR.**
- BRIGGS MFG. CO., THE;** Ira G. Briggs, (C) pres.; John N. Lewis, treas.; G. T. Briggs, gen. mgr.; Thomas A. Hall, supt.; Cotton Yarns (24 to 36); 8888 ring and 2400 mule spindles; water; sell direct. *Closed in definitely.* Also Mill at Voluntown, Ct.
- CENTREVILLE MFG. CO.;** Benj. Kenyon, (C) agt.; Harry Lamphier, supt.; Cotton Yarn;
- 2,000 ring and 2,000 mule spindles; steam and water; sell direct; agt. and supt., buyers.
- Saylesville, B-11, Mos. Val. RR.**
- CREFFELD WASTE & BATTING CO.;** \$250,000; (C) L. A. Lockwood, pres.; Chas. F. Burnham, treas. and agt.; Robert Steere, supt.; Cotton Mill Wastes and Batting; 18 cards; steam; sell direct; Chas. F. Burnham, buyer.
- GLENLYOX DYE WORKS;** \$400,000; (D, BI & F) Frank A. Sayles, pres.; Chas. O. Read, treas.; W. T. Barrow, agt. and supt.; Dyers and Finishers of Cotton and Wool Dress and Fabrics, also Yarns in Skein and Chain Warps and Bleaching Yarns; steam; W. T. Barrow, buyer. *Also See Providence.*
- LOCKWOOD CO., THE L. A.;** \$250,000; L. A. (C) Lockwood, pres. and gen'l mgr.; Chas. F. Burnham, treas.; Converters of Cotton, Wool and Silk Goods; sell direct, 54 Leonard St., N. Y.; L. A. Lockwood, buyer.
- LORRAINE MFG. CO.;** see Pawtucket. (C)
- SAYLES, F. A., prop.;** Sayles Bleach- (BI & F) eries; Chas. O. Read, supt.; Bleaching and Finishing Cotton Piece Goods, 60 tons per day; steam.
- Scituate.**  
See No. Scituate and South Scituate.
- Shannock, E-10, N. Y., N. H. & H. RR, Ston. Div.**
- COLUMBIA NARROW FABRIC CO.;** \$100,000; (C&S) Geo. H. Clark (Shannock), pres.; Geo. P. Clark, treas.; Samuel Ward, supt.; Cotton and Silk Elastic and Non-Elastic Tapes, Webblings, etc.; finish. (Formerly at Prov., R. I.)
- BURNSIDE MILL;** W. P. Barney; Yarns (W) for Warps; 1 set; 480 spindles; steam and water; dye. (Mill at Green Hill, 6 miles; stage at Westerly or Wakefield.)
- SHANNOCK NARROW FABRIC CO.;** \$10,000; (C) C. S. Davison, pres.; John Crowther, treas.; Various Kinds of Narrow Fabrics; 12 looms; water; electric power; sell direct. Buy cotton yarns from 10/3 to 120/2.)
- Slatersville, A-11, N. Y., N. H. & H. RR, B. & P. Line.** Also stage 2m at Mill River, Mass. and Woonsocket.
- SLATERSVILLE FINISHING CO.;** (D, BI & F) \$300,000; T. Parsons, pres.; James S. Hooper, treas.; E. A. Emerson, supt.; Bleachers and Dyers; Cotton Goods, Yarns and Raw Cotton; (25 tons per day). Boston office, 110 Summer St; (Purchased plant Slater Mills Corp'n.)
- Stocumville, D-11, N. Y., N. H. & H. RR, Ston. Div.**
- CLARK, B. A., agt.;** Yawgoo Woolen (W) Co.; Satinets; 2 sets; 14 looms. *Reported not running.*
- So. Scituate, B-10, Station at Hope on N. Y., N. H. & H. RR, Pawtuxet Valley Br. and Stage at Providence.**
- ASHLAND CO.;** \$72,000; F. H. Allen, (C) treas. and buyer; C. H. Lawton, supt.; Cotton sheetings; 2800 11mg and 2780 mule spindles; 116 looms; steam and water; C. H. Pope & Co., N. Y., s. agts.
- JOSLIN MFG. CO.;** Richmond Mill; Shoe (C) and Corset Laces; 16,800 spindles; 2000 braiders; water and steam; dye; sell direct. (See main mill at Prov.; also branch at Rockland.)
- Stillwater, B-11, N. Y., N. H. & H. Cen. Div.**
- CENTREDALE WORSTED MILLS;** Worsted (W) Yarns; water and steam; dye. (See Centre-dale.)
- Tarklin, A-10, N. Y., N. H. & H. RR, Cen. Div.**
- OAK VALLEY WOOLEN MILL;** H. E. (W) Mowfy, prop.; Fancy Worsteds; 5 sets; 22 looms; water and steam; dye; sell direct.

- Thornton.** B-11. RR. Station, Providence.  
**FITCH, SAM'L MFG. CO.** See *Providence, R. I.*  
**PECKHAM, LEE W.;** Shoddy and Waste; (**W**) 5 pickers; 12 cards; 2 garnet machines; dye and carbonize; water and steam.
- POCASSET WORSTED CO;** Chas. Flet. (**W**) cher, pres; E. C. Fletcher, treas; Frank Baldwin, supt.; Worsted Yarns English system; 10,000 spindles; steam; sell direct; Prov. office, Banigan Bldg. (Building new mill, 10,000 spindles; expect to have completed, Jan., '03.)
- VICTORIA MILLS; H. Hartley,** (620 At. (**W**) lantic Ave, Boston,) prop; E. Bedford, supt; Worsted Tops and Noils; 11 combs; 13 worsted cards; steam; sell direct from Boston, H. Hartley, buyer.
- Tiverton.** D-12. N. Y, N. H. & H. RR, Taunton Div.  
**BOURNE MILLS; See Fall River, Mass.**
- Valley Falls.** B-11. N. Y, N. H. RR, Wor. Div.  
**CUMBERLAND MILLS CO;** \$100,000; Chas. (**C**) E. Pervear, pres; Frank Lenod, treas; P. A. Horton, agt; Jas. F. Stewart, supt; Hosiery and Skein Yarns and Thread; 2912 ring and 3336 mule spindles; steam and water; sell direct; P. A. Horton, buyer. (P. O. address, Pawtucket).
- RELLING, DAVID, & SCHOEN;** 50 looms (to **S**) be increased to 100 by Fall. See main office and mill at West Hoboken, N. J.
- SAMOSSET CO;** (formerly Albion Co); (**C**) \$225,000; Jonathan Chace, pres; Edward B. Jennings, treas; John Ramsbottom, supt.; Lawns, Shirtings, Sheetings, etc.; 31,140 ring and 7200 mule spindles; 968 looms; steam and water; sell direct; Edward B. Jennings, buyer.
- VALLEY FALLS CO.** See Albion, R. I.
- WOOD, FRANK MFG. CO.;** Wm. Hincliffe, (**S**) supt; Fancy Tapes, Etc; 1 narrow and 16 broad looms; steam; sell direct; Frank Wood, buyer. (Buy 12/2 to 120/2 yarn.)
- Warren.** C-12. N. Y, N. H. & H. RR, Fall River Branch.  
**CUTLER MFG. CO;** \$300,000; Richard A. (**C**) Lewis, pres; Frank Hail Brown, treas, and agt; Fred R. Simmons, supt; Hosiery Yarns, 5 s to 26 s, American and Egyptian Cottons; 11,500 ring and 13,000 mule spindles; steam; Wm. D'Olier & Co, Phila, s. agts; F. H. Brown, buyer.
- PARKER MILLS;** Fine Cotton Goods; 41,344 (**C**) ring spindles; 434 looms. See *Fall River*. (Building new weave shed of about 1500 looms.)
- WARREN MFG. CO;** \$600,000; C. F. Drowne, (**C**) treas.; Arnold Schaer, supt.; Sheetings, Cambrics, Fine Twills, Satens and Yarns; 31,616 ring and 49,416 mule spindles; 2120 looms; steam; sell direct.
- Washington.** C-11. N. Y, N. H. & H. RR, Cent. Div.  
**COVENTRY WORSTED MILLS;** \$50,000; (**W**) George Washington Brown, pres; Phillip L. Schell, treas.; Joseph Dews, agt.; F. S. Dews, supt.; Fancy Worsteds; 40 looms; water and steam; sell direct; 377 Broadway, N. Y.; F. S. Dews, buyer.
- LIVINGSTONE WOOLEN MILLS;** \$50,000; (**W**) Joseph Dews, agt. and gen'l mgr.; Fred S. Dews, supt; Fancy Worsteds; 49 looms; steam and water; dye; sell direct; 377 Broadway, N. Y.; F. S. Dews, buyer.
- MOON, BENJAMIN;** Cotton Twines; 2000 (**C**) spindles; 4 sets; water.
- PECKHAM MFG. CO.** (Purchased by Rob. (**W**) ert Knight); *Mill idle*. (Not known what will be done).
- SPRING LAKE MFG. CO;** John Galvin, (**W**) mgr; Woolen Yarns; 8 sets; steam and water; sell direct.
- Waterford.** A-11. (Not shown on map.) (**W**) near Blackstone, Mass.  
**SARANAC WORSTED MILLS;** See Black- (**W**) stone, Mass.
- Westerly.** E-9. N. Y, N. H. & H. RR, Ston. Div.  
**CAMPBELL MILLS.** See Potter Hill.
- CLARK, WM, MILLS;** (Am. Thread Co); (**C**) L. R. Hopkins, pres.; T. M. Ives, treas.; Wm. Clark, gen. mgr; Fine Cotton Yarns; steam; dye; sell direct; Albany Bldg., Boston Mass. Mill in Stonington, Ct.
- LORRAINE MFG. CO;** Crefeld Mills; (**C**) \$1,250,000; F. A. Sayles, pres; J. R. MacColl, treas; J. H. Blades, supt; Dress Goods, Shirtings; 12,332 ring and 1472 mule spindles; 612 looms; steam; Lorraine Mfg. Co, 53 Leonard St., N. Y, s. agt; J. H. Blades; buyer. (Also Pawtucket, R. I.)
- SOLWAY MILLS;** (Co-partnership, A. E. (**C**) Henry and Robert Dow); Fancy Colored Cotton Goods; 250 looms; steam and water; sell direct. (Buy cotton yarns, 20s to 80s.) (Formerly the Walker Mill.)
- WESTERLY SILK MILL CO;** \$15,000; John (**S**) W. Conant, pres; E. E. Bradley, treas; John W. Conant, agt. supt. and buyer; Machine Twist and All Kinds of Twisted Silk Threads thrown on commission; 1600 spindles; steam.
- WESTERLY WOOLEN CO, W. O. & L. W. (**W**) Arnold;** L. W. Arnold, agt; Edgar Chase, supt; Cassimeres and Worsteds; 24 sets; 120 looms; steam and water; dye.
- White Rock.** E-9. Station at Westerly, on N. Y, N. H. & H. RR, Ston. Div.  
**WHITE ROCK MFG. CO;** \$300,000; Robt. (**C**) Knight, pres, and treas; Howard Pember, supt; Sheetings; 12,304 ring and 15,800 mule spindles; 705 looms; water and steam; sell direct; Wm. H. O'Neill, Prov., buyer.
- Wickford.** D-11. N. & W. RR.  
**BELLEVILLE MFG. CO.** See Allenton.
- OAK HILL MILL;** Wickford Worsted (**W**) Mills, (Inc.); Unions and Worsteds Goods; 2 sets; 12 looms; water and steam; dye; E. Mitchell & Son, and Greeley, Cushman & Record, s. agts.; A. W. Gregory, buyer.
- WICKFORD WORSTED MILLS;** (Inc.); \$100, (**W**) 000; Mrs. Harriet Gregory, pres; Albert W. Gregory, sec. and treas.; Fine Worsteds Goods; 3 sets; 28 looms; steam; dye; E. Mitchell & Son, and Greeley, Cushman & Record, s. agts; A. W. Gregory, buyer. (Buy 32/2, 32/2 worsted and 40/2, 26/2 cotton yarns.) See also Oak Hill Mill.
- Woodville.** E-10. Wood River Br. RR.  
**KENYON, JOHN T.;** H. C. Kenyon, supt; (**C**) Cotton Yarns, Single and Twisted on Cones, Tubes or Skeins 4s to 10s; 1500 spindles; water; sell direct; J. T. and H. C. Kenyon, buyers.
- Woonsocket.** A-11. B. & P. Line, & A. Divs; N. Y, N. H. & H. RR, Wor. Div.  
**BANFILL KNITTING MILLS;** O. D. Banfill, (**K**) prop. and mgr; Case Ave; Knit Goods, Jersey Stockings and Eiderdowns.
- BERNON KNITTING CO.** *Plant sold to Stiles Knitting Co.*
- CLINTON MFG. CO;** \$120,000; Webster (**C**) Knight, (Prov), pres; Robt. Knight, (3 Washington Row, Prov.), treas; H. K. Drew, supt; Sheetings; 12,624 ring and 11,520 mule spindles; 614 looms; steam and water; sell direct; Wm. O'Neil, buyer.
- COLCHIS MILL.** See Glenark Knitting Co.
- DUNN WORSTED MILLS;** (Inc. 1895); J. B. (**W**) Dunn, pres; E. S. Dunn, treas; Worsteds Sulfings and Piece Dyes for Men's Wear; 112 looms; steam and water; dye; sell direct; E. S. Dunn, buyer. (Buy yarn 1/4 to 1/2 blood and Aus.)

- EAGLE MILLS**, office 20 Market Sq. Prov.; (C) \$80,000; Geo. H. Grant, supt.; Fancy Dress Goods, Satens, Brocades and Plushes; 13,500 spindles; 502 looms; water and steam; dye; C. M. & G. M. Smith, Prov., s. agts.
- FAIRMOUNT TEXTILE CO.**; Albert Fowden, (C) mgr.; Corduroys; 30 looms; steam and water.
- FALLS YARN MILLS**; Joseph Cavedon (W) and Theophile Guerin (Woolsocket); Woolen and Merino Yarns; (Belgian System); 2800 mule spindles; 4 sets; steam; sell direct; Theo. Guerin, buyer.
- GLENARK KNITTING CO.** \$400,000; C. B. (K) Fillebrown, pres.; E. A. Stevens, treas.; A. J. Follett, sec.; Brigham Payne and Irving T. Peckham, supts.; Stockinets, Jersey Cloth, Fleeces, etc.; 213 knitting machines; steam; dye; C. B. Fillebrown & Co, Woolsocket and N. Y., s. agts.
- GLOBE MILL**. See Manville Co.
- GUERIN SPINNING CO.** \$100,000; Stanley (W) G. Smith, pres.; Aram J. Pothier, treas.; Jos. Guerin, gen. mgr.; Latimer W. Ballou, agt.; Woolen and Merino Yarns; 6 sets; water and steam; dye; sell direct; mgr. and agt., buyers.
- HAMLET TEXTILE CO.** \$500,000; Chas. E. (C) Thomas, pres. and treas.; Robt. G. McMechan, supt.; Book Cloths, Sheetings, Twills and Shirtings; 8,320 ring and 9,056 mule spindles; 407 looms; water and steam; sell brown goods direct; bleached, Treat & Converse, s. agts.; Chas. E. Thomas, buyer.
- HART TEXTILE CO.** \$200,000; (D Pr & F) John J. Hart, pres. and gen'l mgr.; Cutting, Printing, Dyeing, Finishing Corduroys, Velvets, Plushes and Pile Fabrics; water and steam; dye.
- HOUGH, MARK**; Enterprise Dye Works; (D) 195-200 First Ave.; Dyer of Cotton, Woolen and Worsted Braids and Skein Yarns and Knit Goods.
- KNIGHT, A. F.**; 39 Main St.; M. W. Hud. (C) son, supt.; Satens, Twills, Fancies, Yarn on Beaus, Skeins, Balls, Cones and Cops; 5,350 ring and 7,360 mule spindles; 228 looms; water and steam; sell direct. Bought Farnumville Cotton Mills, Farnumville, Mass., May, '02.
- LAFAYETTE WORSTED CO.** \$300,000; An. (W) dre Simonis, pres.; Pierre Mall, treas.; Auguste Lepoutre, vice pres.; Charles Devin, sec.; Fine French Spun Worsted Yarns; 17,000 spindles.
- LAWTON SPINNING CO.** Mill No. 2; L. R. (C) Peek, pres.; W. O. Todd, treas.; Wm. Halliwell, agt.; J. Walsh, supt.; Threads, Fine Cotton Yarns; 50,000 spindles; steam and water; J. E. Mitchell, Boston, and Callin & Co., N. Y., s. agts. (Also Prov.)
- LEICESTER KNITTING MILL**; G. H. (K) Baker, prop.; Mittens and Jersey Under-vests; 100 knitting machines; water and steam; dye; Knitting Mills Trading Co., N. Y. and Boston, s. agts.
- LIPPITT WOVEN CO.** \$400,000; C. H. (W) Merriman (Providence), treas.; R. L. Lippitt, agt.; H. T. Merriman, supt.; Fancy Cassimeres, Worsteds, and Coatings; 75 looms; steam and water; dye; Earncliffe Worsted Co., 377 Broadway, N. Y., s. agts.
- LORDIAN WORSTED CO.** \$300,000; Chas. (W) Lordian, pres. agt. and supt.; Ambrose Feely, treas.; Worsted Yarns Spun on French System, from 15s to 80s, all counts; steam; sell direct; Chas. Lordian, buyer.
- MANVILLE CO.** (formerly Social Mfg. Co.); (C) \$6,000,000; Chas. W. Lippitt, pres.; Chas. H. Merriman (Providence), treas.; H. F. Lippitt, agt.; W. N. Kimball, supt.; Sheetings, Shirtings, Silesias, Warp and Filling Satens, Zanella Goods; 68,608 ring and 68,292 mule spindles; 3466 looms; steam and water; sell direct. (office Board of Trade Bldg., Prov.) Also see Manville.
- MASON, GEO.** (formerly American (C & W) Narrow Fabric Co.); Braids and Tapes; 100 braiding machines; 50 looms; Watson, Porter, Giles & Co., N. Y., s. agts. (Buy cotton and worsted yarns.)
- MODEL SPINNING CO.**; Woolen and (W) Merino Yarns, fine heavy numbers; Spin on Commission; 2 sets; (Belgian system); water; sell direct.
- MORRILL KNITTING CO.** 297 No. Main St.; (K) \$100,000; E. H. Rathbun, (Franklin), pres.; Geo. H. Emmott, treas.; F. A. Morrill, gen'l mgr.; Knit Goods, Fleeces Eiderdown, Jerseys and Stockinets; 19 tables; steam; dye; sell direct. (Buy cotton yarns, 1/108 to 1/45s, cops or cones, woolen 40 gr. to 130 gr., tubes or bobbins, worsted 1/30s, 1/50-, 1/60s, 1/70s cops.)
- NATIONAL PILE FABRIC CO.** \$100,000; J. (C) M. R. Taylor, pres. and mgr.; Wm. Macartins, treas.; A. R. Gee, supt.; Corduroys, etc.; 150 looms; steam; sell direct.
- NEW ENGLAND EDGING CO.**; S. T. Stiles, (K) mgr.; Lace Ribbed Underwear; 12 knitting machines; steam; Geo. W. Chapin, Phila., s. agt. (Buy 2/20, 2/60 yarn.)
- NOURSE MILLS**; Manville Co.
- PERSEVERANCE WORSTED CO.** \$100,000; (W) Jas. H. Singleton, treas. and agt.; J. Eric T. Singleton, supt.; Men's Fancy Worsted Goods; 85 looms; steam; dye; sell direct; F. E. Warren, 72 Leonard St., N. Y., s. agt. (Buy worsted yarns.)
- PRUE, FRANK J. & Co.**; Eli Gareau, (K) supt.; Jersey Ribbed Underwear, Worsted Mittens and Gloves; 18 knitting machines; buy yarns; steam; sell direct; F. J. Prue, buyer.
- RELIANCE WORSTED CO.** \$100,000; W. L. (W) Youngman, pres.; Phillip Henault, treas. and mgr.; John Campbell, vice pres.; Worsteds and Woolen Men's Wear; 3; broad looms; steam and water; d c; Duval & Cone, N. Y., s. agts.
- RIVER SPINNING CO.** \$250,000; F. C. (W) Sayles, pres.; F. S. Drown, (Providence), treas.; Andrew Adie, agt. and supt.; Woolen and Merino Yarns (Belgian System); Wool Scoured and Carbonized; 17,000 spindles; 16 sets; steam; dye; sell direct.
- SAYLES & GILLERAN**; H. F. Sayles, pres. (W) and treas.; J. F. Gilleran, supt.; Fancy Worsteds and Suitings; 27 looms; steam; dye; sell direct and Duval & Cone, 79 & 81 Worth St., N. Y., s. agts.; H. F. Sayles, buyer. (Buy 2/26, 2/30 and 2/42, also worsted yarns.)
- SIMSON & KIRKALDY**; Fancy Worsteds; (W) 47 looms; steam; dye; Knower & Turnbull, N. Y., s. agts.
- STILES KNITTING CO.** E. W. THE; 598 (K) Park Ave.; Fine Worsted Mittens and Knit Stocking Feet; 11 knitting machines; steam; G. A. Miller, Boston, and E. W. Green, 450 Broadway, N. Y., s. agts.; sell feet direct; E. W. Stiles, buyer.
- UNITED STATES RUBBER CO.**; Felt Boots; (K) 13 sets; 40 knitting machines; steam. Machinery removed to Lawrence Feltng Co., Millville, Mass.
- NASHON CO.** \$200,000; M. G. Chace, pres.; (C) G. C. Hinckley, treas.; W. P. Clark, supt.; Wash Goods; 343 looms; water; J. P. Stevens & Co., s. agts. (Formerly Valley Falls Co.'s mill.)
- WOOLSOCKET WORSTED MILLS**; Edwin (W) Wilcock, pres.; Wm. R. Corbridge, treas.; Edwin Farnell, agt.; A. Farnell, supt.; Worsted Yarns (40 to 70) Fine and Medium; (English system); 8 sets; 7 Noble combs; 4000 worsted spindles; steam; dye; sell direct; 570 Atlantic Ave, Boston.

#### Wyoming. D-10. Stage at Hope Valley, on Wood River Br.

**WYLIE MFG. CO.** W. H. THE; (formerly S) Monopole Weaving Co.; \$10,000; W. H. Wylie, mgr.; Broad Silks, Cotton Back Satins, Yarn and Piece Dye Taffeties and Tuffetas, etc.; 58 looms; water and steam; Passavant & Co., N. Y., s. agts.

**WYOMING FLOCK CO.**; Flocks and Shod-(W) dies; 5 double cards; water; dye.

# SOUTH CAROLINA.

See map on page 264

For explanation of abbreviations see page 66.

- Abbeville.** D-3. S. Ry. Co.; S. A. L. RR.  
**ABBEVILLE COTTON MILLS;** \$700,000 (\$645,-(C 200 paid in); B. F. Bailey, pres. and treas.; G. A. Visanska, vice-pres.; E. A. Thompson, supt.; 3-yard Sheetting; 28,800 spindles; 42 revolving flat top cards; 940 looms; steam; Deering, Milliken & Co., s. agts.; G. A. Visanska, buyer.
- Aiken.** E-4. S. C. & G. RR.  
**CROFT MANUFACTURING CO;** \$250,000; (C Print Cloths. (All communications addressed to Chas. Warren Davis, 5 Library Bldg, Augusta, Ga., at present.) *Projected. Not yet built.*
- Anderson.** D-2. P. R. & W. C. RR.; S. Ry. Co.  
**ANDERSON COTTON MILLS;** \$600,000; J. A. (C Brock, pres. and treas.; Robt. E. Ligon, mgr.; J. A. Morris, supt.; 56,660 Four-yard Sheettings; 61,000 spindles; 1864 looms; steam and electric; Woodward, Baldwin & Co, N.Y. and Balto., s. agts.; R. E. Ligon, buyer.  
**COX MFG. CO;** \$100,000; W. F. Cox, pres. (C and treas.; M. B. Pitts, supt.; Cotton Yarns, 40/1, 40/2 Skein, 40/1 Chain and Ball Yarns; 7536 ring spindles; steam; sell through agents; W. F. Cox, buyer.  
**ORR COTTON MILLS;** \$400,000; James L. (C Orr, pres.; Calhoun Harris, sec.; J. B. Loflin, supt.; 31 yd. and 36 inch Sheettings; 25,000 spindles; 700 looms; steam and electricity; Woodward, Baldwin & Co, N. Y. & Balto., s. agts.; Jas. L. Orr, buyer.  
**RIVERSIDE MFG. CO;** \$200,000; D. P. Mc. (C Brayer, pres. and treas.; J. W. Roberts, supt.; Single and Ply Warps and Yarns; 208 to 308; (double roving spun); 9,248 ring spindles; steam; James E. Mitchell & Co., s. agts.  
**TOWNSEND, H. C.;** Wrapping Twine; (C electricity; H. C. Townsend, buyer. *Proposed.*
- Arlington.** C-3. S. Ry. Co.  
**ARLINGTON COTTON MILLS;** \$20,000; Lewis (C W. Parker, pres. and treas.; J. F. Henderson, supt.; Twist Yarns; 2000 ring spindles; water; Carlin & Co., s. agts.; L. W. Parker, buyer. (RR Station, Greens, one and three-fourths miles distant.)
- Autun.** C-2. S. Ry. Co.  
**PENDLETON MFG. CO.;** A. J. Sitton, prop., (C B. M. Aull, mgr.; J. E. Massey, supt.; Carpet Yarns and Warps, 3- to 168 inclusive; 2500 spindles; water; J. E. Mitchell & Co, Phila. and Boston, s. agts.
- Bamberg.** E-4. S. C. & G. RR.  
**BAMBERG COTTON MILLS;** \$137,000; E. R. (C Hays, pres.; J. H. Cope, sec. and treas.; J. T. Cartee, supt.; Sheettings, 36 in-44x44-6.00 and 36 in. -44x36-6.50, 26/2 and 26/3 Ply Skein Yarn; 10,752 ring spindles; 248 looms; steam; Woodward, Baldwin & Co., s. agts. for cloth; Buckingham, Paulson & Co., yarns; J. T. Cartee, buyer.
- Batesburg.** D-4. Sou. Ry.  
**MIDDLEBURG MILLS;** (formerly Bates-Cburg Cotton Mill); \$75,000; W. P. Roof, pres.; C. H. Foster, vice-pres. and agt.; Allen Jones, sec. and treas.; sheettings and Yarns; 6240 spindles; 352 looms; steam; H. J. Farber, Drewry & Co, N. Y., s. agts.
- Bath.** E-3. S. Ry. Co.; S. C. & G. RR.  
**AIKEN MFG. CO.;** \$400,000; Thos. Barrett, (C Jr., pres.; Chas. Estes, treas.; J. M. Timmerman, supt.; Print Cloths, Sheettings, Shirts and Drills; 27,000 spindles; 766 looms; steam and water; W. H. Langley & Co., N. Y., s. agts.; A. H. McCarrel, buyer.
- Belton.** C-3. Sou. Ry.  
**BELTON MILLS;** Smythe Mfg. Co; \$600,000 (C authorized); (\$400,000 paid in); E. A. Smythe, pres.; Lewis D. Blake, sec. and treas.; W. C. Cobb, supt.; Sheettings, Shirts and Drills; 27,000 ring spindles; 700 looms; steam; Woodward, Baldwin & Co, N. Y. & Balto., s. agts.
- Bennettsville.** C-6. B. & S. H. RR. C. F. & Y. V. RR. C. S. & N. RR.  
**BENNETTSVILLE MFG. CO.;** \$227,200; D. D. (C McColl, pres.; J. F. Everett, treas.; P. H. Phillips, supt.; Yarns, Skeins, Chains, Beams, Warps; 15,000 ring spindles; steam; sell through agents.
- Blacksburg.** C-4. O. R. & C. RR.; S. Ry. Co.  
**BLACKSBURG SPINNING & KNITTING CO.;** (K \$25,000; J. J. Whisonant, pres. and treas.; Men's Half Hose and Misses' Ribbed Hose, Fast Black and Tan; 80 knitting machines; steam, dye.  
**CHEROKEE FALLS MFG. CO.;** \$200,000; J. (C C. Plonk, pres.; R. P. Roberts, treas.; J. R. Killian, supt.; 40 to 45 in-Print Cloths; 15,520 ring spindles; 548 looms; water; Carey, Bayne & Smith Co, N. Y., s. agts. (Mill at Cherokee Falls.)
- Blackville.** E-4. C. M. RR.; S. C. & Ga. RR.  
**PALMETTO KNITTING MILLS;** J. P. (K Strobel, pres.; Ladies' and Men's Cotton Hosiery; 32 knitting machines; 6 loopers; 6 sewing machines; 2 ribbers; dye; Wagner & Gibbs, s. agts.
- Bowling Green.** C-4. C. & N. RR.  
**BOWLING GREEN KNITTING MILLS;** \$15,- (K 000; T. J. Patrick, pres.; R. M. Dulin, treas.; G. S. Marville, supt.; Ribbed Underwear and Union Suits; 14 knitting machines; steam.
- Camden.** D-5. O. R. & C. RR.; S. C. & G. RR.  
**CAMDEN COTTON MILL;** \$200,000; P. T. (C F. M. Zemp, pres. and treas.; R. W. Mitcham, supt.; 68/2 43, 39-inch Cotton Goods and Warp Yarns; 12,000 spindles; 300 looms; steam and water; Woodward, Baldwin & Co, N. Y., s. agts.
- DEKALB COTTON MILLS;** \$300,000; E. M. (C Boykin, pres. and treas.; T. C. Duncan, vice-pres.; R. W. Mitcham, supt.; 72x80-39" 4 1/2 yd. Goods; 10,266 ring spindles; 260 looms; steam; Carey, Bayne, Smith Co., s. agts., supt. and sec., buyers. (Adding 5000 spindles and 150 looms.)
- Catechee.** C-2. (RR. Station, Central, 5 miles); S. RR.  
**NORRIS COTTON MILLS CO.;** \$200,000; D. (C K. Norris, pres. and treas.; W. Woods, supt.; Wide Sheettings; 13,280 spindles; 352 looms; electricity and water; P. Van Volkenburgh & Co., s. agts.; D. K. Norris, buyer.
- Central.** C-2. S. Ry. Co. *See Catechee.*
- Charleston.** F-6. S. C. & G. RR.; A. C. L. RR.; C. & S. RR.  
**CHARLESTON BAGGING MFG. CO.;** \$300,000; (C J. S. Murdock, treas., mgr. and sec.; W. W. Shackelford, supt.; Cotton Bagging; 55 looms; steam; sell direct; J. S. Murdock, buyer.  
**ROYAL BAG & YARN MFG. CO.;** \$225,000; (C Geo. A. Wagener, pres.; Geo. Lunz, treas.; Seamless Cotton Bags; 5,000 spindles; 200 bag looms; steam.  
**VESTA COTTON MILLS.** *Closed.* (Machinery removed to Gainesville, Ga.)
- Chester.** C-4. S. Ry. Co.; S. A. L. RR.; C. & C. RR.; C. & L. RR.

- EUREKA COTTON MILLS;** \$150,000; Leroy (C) Springs, pres; W. C. Thompson, treas; Thomas Williams, supt; Hosiey Yarns from 12s to 30 s; single and 2-ply in Warps, Skeins and Balls; 15,000 spindles; steam; C. J. Webb & Co., Phila. s. agts; Leroy Springs, buyer.
- SPRINGSTEIN MILLS, TIE;** \$100,000; Leroy (C) Springs, pres; Wm. G. Nichols, sec. and treas; J. A. Green, supt; Gingham, etc; 6720 spindles; 470 looms; steam; dye; Fred K Victor & Achelis, N.Y. s. agts; W. G. Nichols, buyer.
- WYLIE MILL;** \$100,000; Geo. A. Gray, (Gas-C) tonia, pres; Holmes Harden, Jr., sec. and treas; W. J. Johnson, supt; Yarns, 30s to 40s; 5000 spindles; steam; Chas. J. Webb & Co, s. agts.; W. J. John-on, buyer.
- Clearwater.** So. Ry.
- CLEARWATER BLEACHING & MFG. CO.** See Augusta, Ga.
- Clemson College.** C-2. S. RR. Co.
- CLEMSON COLLEGE; TEXTILE DEPT. (CW&D)** J. M. Beaty, Director; Machinery for in- struction purposes. (RR. station at Fort Hill.)
- Clifton.** C-3. S. Ry. Co.
- CLIFTON MFG. CO;** \$1,000,000; A. H. (C) Twichell, pres and treas; John E. Shea, No. 1 and 3, A. B. Wessinger, No. 2, supts; Sheetings and Drills; 101,024 spindles; 3254 looms; water and steam; Eldredge, Lewis & Co, Boston and N. Y. and J. L. Bailey & Co., s. agts.; A. H. Twichell, buyer.
- Clinton.** D-3. C. N. & L. RR., and S. A. L. RR.
- CLINTON COTTON MILLS;** (inc. 1896); (C) \$150,000; M. S. Bailey, pres.; Wm. J. Bailey, treas.; J. W. Wright, supt; Fancies and Convertible Cotton Goods; 17,452 ring spindles; 450 looms; steam; sell direct; W. J. Bailey, buyer.
- LYDIA COTTON MILLS;** \$60,000; M. S. Bailey (C) pres.; C. M. Bailey, treas.; Fancy Goods; 5,000 ring spindles; 150 looms; Haines & Bi-hop N. Y., s. agts. *Under construction, March, 1902.*
- Clio.** C-6. Atlantic Coast Line.
- OCTOBERO MILLS CO;** \$30,000; (formerly (C) Red Bluff Mills); C. W. Worth (Wilmington, N. C.), pres; J. S. Woodward, Phila., treas; Jno. H. Rawlins, supt; Cotton Yarns, 12s to 26s, one and Two Ply; 5000 ring spindles; steam and water; Jas. E. Mitchell & Co., s. agts.
- Clover.** C-4. C. & L. RR.
- CLOVER COTTON MFG. CO;** \$150,000; G. L. (C) Riddle, pres.; M. L. Smith, treas.; W. E. Morton, supt.; Warps, Skeins, Yarns; 40s to 60s; 10,000 ring spindles; steam; sell direct and J. H. Lane & Co, and Catlin & Co., s. agts. (To install 2,500 additional spindles.)
- Columbia.** D-4. S. Ry. Co.; A. C. L. RR.; C. N. & L. RR.; F. C. & P. RR.; S. C. & G. RR.
- CAPITAL CITY MILLS;** 3-yd. Sheetings; (C) 6200 ring spindles; 200 looms; electricity; Carey, Bayne & Smith Co., s. agts.
- COLUMBIA HOSIERY MILLS;** (G. H. Tilton, (K) Tilton, N. H., prop; J. M. Graham, mgr; Cotton Ho-tery; 400 machines; electric and steam; dye; Wesendonck, Lorenz & Co., N. Y., s. agts.
- COLUMBIA MILLS CO;** \$1,000,000; F. P. (C) Carpenter, pres; C. K. Oliver, treas, and agt.; L. I. Guion, supt.; Cotton Duck; 20,000 ring spindles; 429 looms; electric ity; Catlin & Co, N. Y. and Boston, Putnam, Hooker & Co, Cincinnati and St. Louis, and H. Channon Co, Chicago, s. agts.; James E. Hooper, buyer.
- GRANBY COTTON MILLS;** (inc. 1895); \$800. (C) 000; W. B. Smith Whaley, pres.; Wm. H. Rose, treas.; J. S. Moore, gen'l mgr.; B. F. Barnes, gen'l supt.; F. M. Sharpe' supt.; 643643s; Print Cloths; 57,000 ring spindles; 1500 looms; electric power; Carey, Bayne & Smith Co., Balto. and N. Y., s. agts.; J. S. Moore, buyer.
- OLYMPIA COTTON MILLS;** \$1,750,000; W. (C) B. Smith Whaley, pres.; Wm. H. Rose, treas.; J. S. Moore, sec. and gen'l mgr.; B. T. Barnes, gen'l supt.; E. Shealy, supt.; Print Cloths; 104,000 ring spindles; 2400 looms; steam and electricity; Carey, Bayne & Smith Co., N. Y. and Balto., s. agts.; J. S. Moore, buyer.
- PALMETTO COTTON MILLS;** \$125,000; Allen (C) Jones, pres. and treas; T. F. Griffith, supt; 92 64 Bedford Cords; 8,500 ring ring spindles; 250 looms; electricity; H. J. Farber, Dreyfus & Co., s. agts.; T. F. Griffith, buyer.
- RICHLAND COTTON MILLS;** \$450,000; W. B. (C) Smith Whaley, pres.; Wm. H. Rose, treas.; J. S. Moore, sec. and gen'l mgr.; B. F. Barnes, gen'l supt.; John K. Hayes, supt.; Twills and Fine Sheetings; 26,112 ring spindles; 720 looms; steam; Carey, Bayne & Smith Co., s. agts.; J. S. Moore, buyer.
- Cowpens.** C-3. S. Ry. Co.
- COWPENS MFG. CO.;** \$60,000; R. R. Brown, (C) pres, treas, and agt; W. A. Rogers, supt; Brown Sheetings; 10,000 spindles; 264 looms; steam; Robinson & Shackelton, s. agts.; R. R. Brown, buyer.
- MARY LOUISE MILL;** \$20,000; B. E. Wil. (C) kins, pres, and treas; A. L. Quinn, supt; Coarse Yarns; 1040 spindles; steam and water; Catlin & Co, N. Y. and Boston, s. agts.
- Darlington C. H.** D-6. A. C. L. RR.; C. S. & N. RR.
- DARLINGTON MFG. CO.;** \$500,000; W. E. (C) Lucas, pres, and treas; E. M. Mathews, sec. and buyer; F. Hamilton, supt; Fine Goods; 41,000 ring spindles; 116 looms; steam; Deering, Milliken & Co., N. Y., s. agts.
- Dillon.** D-6. Atlantic Coast Line R. R.
- DILLON COTTON MILLS;** \$109,000; T. B. (C) Stackhouse, pres; W. M. Hamer, sec. and treas; Hosiey Yarns; 5500 spindles; steam; J. H. Lane & Co., N. Y., s. agts.
- DILLON HOSIERY MILL;** T. B. Stackhouse (K) and W. M. Hamer, owners; W. M. Hamer, agt. and buyer; Hosi and Half Hosi; 23 knitters; 5-sewing machines; steam; sell direct. (Buy 12 to 18s yarn.)
- Easley.** C-3. S. Ry.
- EASLEY COTTON MILLS;** \$250,000; J. M. (C) Greer, pres, and treas; E. H. Shanklin Jr, supt; 4-yd. Sheetings; 11,648 ring spindles; 320 looms; steam; Woodward, Baldwin & Co, s. agts.; J. M. Greer, buyer.
- GLENWOOD COTTON MILL;** \$200,000; W. (C) M. Hagood, pres, and treas.; Fine Sheetings; 10,000 spindles; steam. *Company not yet fully organized, Mar., 1902.*
- Edgefield.** E-4. So. Ry.
- EDGEFIELD MFG. CO. (Inc.);** \$250,000; D. A. (C) Tompkins, pres.; C. J. Burton, vice-pres, and treas.; J. M. Beaty, sec.; Come and Skein Yarns, Sheetings and Shirtings; 5000 ring spindles; 328 looms; steam; sell direct; C. J. Burton, buyer.
- Enoree.** C-3. P. R. & W. C. RR.
- ENOREE MFG. CO.;** \$400,000; Grange S. (C) Coffin, pres, and treas; F. Engels, sec; R. L. Walker, supt.; Sheetings, Drillings (brown); 39,720 spindles; 434 looms; water and steam; Catlin & Co., N. Y., s. agts.; R. L. Walker, buyer.
- Fairmont.** C-3. S. Ry. Co.; P. R. & W. C. RR.
- TYGER COTTON MILLS (formerly Fairmont (C) Mill);** \$100,000; C. P. Mathews, pres, and treas.; 36 in. 48 x 40 5-yd. Sheetings; 6144 spindles; 176 looms; steam and water. (RR. station, Duncans, six miles distant.)



Map of  
**NORTH CAROLINA  
 & SOUTH CAROLINA**  
 Showing the Textile Mill Towns,  
 Specially engraved for the Textile World.  
 Scale 50 Miles to each Square.  
 Copyright, 1935, by *Gould & Lord, Boston.*



**Fingerville.** C.3. S. Ry. Co.; P. R. & W. C. RR.

**FINGERVILLE MFG. Co.;** \$50,000; J. B. (C) Liles, pres. and treas; G. C. Bridges, supt; J. B. Liles, buyer; 2-ply Cotton Yarns; 9,000 ring spindles; water; James E. Mitchell & Co., Phila., s. agts. (RR. station, Spartanburg, 15 miles.)

**Fork Shoals.** C.3. P. R. & W. C. RR.

**FORK SHOALS COTTON MILL Co.;** \$33,000; (C) W. P. Nesbitt, pres. and treas.; A. M. Hatcher, supt.; Cotton Yarns, Nos. 6 to 14 and 2 to 5 Ply; 2,870 ring spindles; water and steam; sell direct; W. P. Nesbitt, buyer. (RR. Station, Fountain Inn.)

**Fort Mill.** C.4. S. Ry. Co.

**FORT MILL MFG. Co.;** \$100,000; Sam'l E. (C) White, pres.; J. E. Williamson, treas. sec. and supt; Leroy Springs, gen. mgr; Staple Gingham; 8,500 spindles; 12 sets; 423 looms; steam; dye; Fred'k Viator & Achelis, N. Y., s. agts.; J. E. Williamson, buyer.

**MILFORD MILL Co.;** \$72,400; Leroy Springs, (C) pres.; J. E. Williamson, treas.; Robert Butler, supt.; Sheetings and Shirtings; 5600 spindles; 336 looms; steam; Fred'k Viator & Achelis, N. Y., s. agts.; J. E. Williamson, buyer.

**Fountain Inn.** C.3. C. & W. C. RR.

**FOUNTAIN INN MFG. Co.;** \$50,000; W. J. (C) Graham, pres; R. L. Graham, treas; J. R. Young, supt.; Yarns, 24s to 40s, 2 Ply; 5,040 spindles; steam; Catlin & Co., and Jas. E. Mitchell & Co., s. agts.; R. L. Graham, buyer.

**Gaffney.** C.4. S. Ry. Co.

**GAFFNEY CARPET MFG. Co.;** \$71,400; W. (W) E. Allen, supt; Ingrain Carpets and Art Squares; 31 narrow and 9 broad looms; steam; dye; H. B. Chaffin Co., N. Y., s. agts. *H. D. Wheat, receiver.* (Buy 2/16, 2/20 worsted, 5/8 grey double and single reel yarn.)

**GAFFNEY MFG. Co.;** \$800,000; H. D. Wheat, (C) pres. and treas.; J. G. Wardlaw sec.; S. L. Cutting, supt.; Print Cloths, Dress Goods, Madras, Fancy Weaves, Lenos, etc.; 67,000 ring spindles; 1401 Draper looms; steam; dye; Carey Bayne & Smith Co., s. agts.; H. D. Wheat, buyer.

**LIMESTONE MFG. Co.;** \$200,000; James A. (C) Carroll, pres; J. Q. Little, vice-pres; W. C. Hamrick, sec. and treas; E. R. Cash, mgr.; Yarns, 26-30. Single and Ply, and Wide Print Cloths, 39in. 68x72; 11,000 ring spindles; 300 looms; Carey, Bayne & Smith Co., s. agts., cloth; W. C. Hamrick, buyer.

**Glendale.** C.3. S. Ry. Co.

**CONVERSE, D. E. Co.;** \$300,000; A. H. (C) Twichell, pres. and treas; John E. Shea, supt; Brown sheetings and Drills; 17,280 spindles; 518 looms; steam and water; Eldredge, Lewis & Co., N. Y., and Boston, s. agts.; A. H. Twichell, buyer.

**Goldville.** D.3. C. & C. RR.

**GOLDVILLE MFG. Co.;** Yarns, 24/3 and 3 (C) ply and 26/2 and 3 ply; 5000 ring spindles; steam; sell direct. *In hands of receiver, Mar., 1902.*

**Graniteville.** E.3. S. Ry. Co.; S. C. & G. RR.

**GRANITEVILLE MFG. Co.;** \$600,000; T. I. (C) Hickman, pres. and treas.; T. H. Rennie, supt. and buyer; J. E. C. Coburn, asst. supt.; Sheetings, Shirtings and Drills; 50,404 spindles; 1674 looms; steam and water; Haines & Bishop, N. Y., s. agts.

**WARREN MFG. Co.** See Warrenville.

**Greenville.** C.3. S. Ry. Co.; P. R. & W. C. RR.; C. K. & W. RR.

**AMERICAN SPINNING Co.;** \$300,000; J. H. (C) Morgan, pres. and treas; W. B. Boyd, sec; T. A. Sizemore, supt.; No. 1 Mill, Yarns;

No. 2 Mill, Sheetings and Drills; 21,000 ring spindles; 352 looms; steam; Catlin & Co.; N. Y. and Boston, s. agts; J. H. Morgan, buyer.

**BATESVILLE MILE;** George Putnam; (C) Warps and Skein Yarns, 10s to 14s; 2600 spindles; water and steam; Catlin & Co, Boston, s. agts.

**BRANDON MILLS;** \$300,000 (authorized); (C) J. I. Westervelt, pres. and treas; F. M'Osteen, supt; Sheetings; 15,232 ring spindles; 400 looms; steam; Woodward, Baldwin & Co., s. agts; J. I. Westervelt, buyer.

**CAROLINA MILLS, THE;** \$50,000; Jos. Nor. (C) wood, pres; P. C. Poug, treas; W. A. Morris, supt; Plied Yarns, 24 to 30; 5834 ring spindles; steam; sell through agts; Jos. Norwood, buyer.

**HUGUENOT MILLS;** \$75,000; C. E. (C) Graham, pres.; W. J. Graham, treas.; G. R. Busbee, supt.; Cottonades, Chevots, Plaids, Outing Cloths and Towels; 6000 spindles; 329 looms; steam; dye; Brander, Walsh & Co, N. Y. s. agts.

**MILLS MFG. Co.;** \$370,000; O. P. Mills, (C) pres. and treas.; James L. Orr, vice-pres, W. B. Moore, mgr. sec. and supt; Fine Twills, Sheetings and Fancy Goods; 27,000 ring spindles; 740 looms; steam; Deering, Milliken & Co., s. agts; W. B. Moore, buyer.

**MONAGHAN MILLS;** \$450,000; Thomas F. (C) Parker (Greenville) pres; Lewis W. Parker (Greers) treas; Alex. Macheth, sec; J. R. Pierce, supt; Prints and Convertibles; 30,000 spindles; 520-40 in. and 200-60 in. looms; steam; Woodward, Baldwin & Co., N. Y. s. agts; Thos. F. Parker, buyer.

**POE, F. W., MFG. Co.;** \$500,000; F. W. Poe, (C) pres. and treas; F. W. Symmes, sec; Convertible Cotton Cloths; 58,340 ring spindles; 1519 looms; steam; Woodward, Baldwin & Co, N. Y. s. agts.; F. W. Poe, buyer.

**Greenwood.** D.3. P. R. & W. C. RR.; S. Ry. Co.; S. A. L. RR.

**GREENWOOD COTTON MILLS;** \$182,750; (C) J. K. Durst, pres. and treas; J. A. Campbell, supt; Sheetings and Drills; 10,000 ring spindles; 384 looms; steam; Woodward, Baldwin & Co., N. Y. and Balto., s. agts; J. K. Durst, buyer.

**GRENDLE MILLS;** \$350,000; A. F. McKis- (C) sick, pres. and treas; J. L. Eddleman, supt; 4 yd. Sheetings; 25,988 ring spindles; 784 looms; steam; Woodward, Baldwin & Co.; N. Y. and Balto, s. agts; A. F. McKissick, buyer.

**MIRIAM TEXTILE MFG. Co.;** \$15,000; T. B. (C) Lee, D. A. P. Jordan and others; Batting.

**Greer Depot.** C.3. S. RR.

**BROOKS MFG. Co.;** \$4,000; E. S. Brooks, (C) pres; W. E. Waldrop, treas; Cotton Bats and Comforts; steam; sell direct; pres. and treas., buyers.

**FRANKLIN MILLS;** \$100,000; W. W. Bur. (C) gess, pres. and treas; Coarse Yarns; 5000 ring spindles; steam.

**VICTOR MFG. Co.;** (inc. 1895); \$350,000; (C) Lewis W. Parker, pres. and treas; H. F. Moody, supt; Wide Print Cloths; 26,680 ring spindles; 684 looms; steam; Woodward, Baldwin & Co.; N. Y. s. agts; L. W. Parker, buyer.

**Hartsville.** D.6. A. C. Line.

**HARTSVILLE COTTON MILL;** \$250,000; C. (C) C. Twitty, pres. and treas; J. M. Moore, supt; Fine Print Cloths, 61x68; 12,000 spindles; 300 looms; steam; Deering, Milliken & Co., N. Y. s. agts; C. C. Twitty, buyer.

**Honeapath.** D.3. Sou. Ry.

**HONEAPATH COTTON MILLS;** \$200,000; J. D. (C) Hammett, pres. and treas.; Sheetings, from 28 to 40 Yarns; 10,000 ring spindles; 270 looms. *Proposed.*

**Inman.** C.3. Sou. Ry.

- INMAN MILLS;** \$500,000 (authorized); (C) James A. Chapman, pres. and treas.; A. S. Winslow, supt.; 16,704 ring spindles; 408 looms; steam and electric; Carey, Bayne & Smith Co., s. agts.; James A. Chapman, buyer.
- Irene.** D-4. S. Ry. Co.
- SAXE-GOTHA MILLS;** \$50,000; W. P. (C) Roof, pres.; Allen Jones, treas.; R. Hilton, supt.; Sheetings; 5000 ring spindles; 242 looms; steam and water; Carey, Bayne & Smith Co., s. agts.; R. Hilton, buyer; (RR station, Lexington, two and one-half miles distant.)
- Johnston.** D-3. Sou. Ry. (of Saluda.)
- ETHREDGE, ALVIN;** \$60,000; Sheetings, (C) Shirtings and Drills; 3000 spindles. *Project abandoned for the present.*
- Jonesville.** C-4. S. RR.
- ALPHA COTTON MILLS;** \$100,000; J. J. (C) Littlejohn, pres. and treas.; W. G. Tise, supt.; White Hosiery Yarns, 88 to 308; 7,000 ring spindles; steam; sell direct; J. J. Littlejohn, buyer.
- JONESVILLE KNITTING MILLS;** \$35,000; (K) J. J. Littlejohn, pres. and treas.; A. L. Bassett, supt.; Hose and Half Hose, 108, 136 and 176 needle; 100 knitting machines; steam; dye; sell direct, 256 Church St., N. Y.
- Lancaster.** C-5. L. & C. RR.; O. R. & C. RR.
- EUREKA MILLS.** See Chester.
- LANCASTER COTTON MILLS;** \$1,000,000; (C) Leroy Springs, pres.; Waddy C. Thomson, sec. and treas.; Charles B. Skipper, supt.; Fine Shirtings and Yarns, 12,500 spindles; 476 looms; steam; Carey, Bayne & Smith Co., s. agts.; W. C. Thomson, buyer. (Adding 53,000 more spindles and 1200 looms. Start operating Sept., 1902.)
- Lando.** Chester Co. C-4. S. RR.; S. A. L. RR.
- MANETTA MILLS;** \$100,000; B. D. Heath, (C) (Charlotte, N. C.) pres.; H. B. Heath, treas.; J. H. Nolan, Yarns, 88 to 408; 7000 ring spindles; steam and water; sell direct and Catlin & Co., s. agts.; H. B. Heath, buyer. P. O. at Factory.
- Landrums.** C-3. Sou. Ry.
- BLUE RIDGE HOSEIERY MILL Co;** \$20,000. (K) 000; Joseph Lee, pres. and treas.; Hosiery; 30 knitting machines; steam; dye.
- Langley.** E-3. S. C. & G. RR.; S. Ry. Co.
- LANGLEY MFG. Co.** (Office, Augusta, Ga.); (C) \$700,000; Thos. Barrett, Jr., pres. and treas.; Arthur T. Smith, supt.; Sheetings, Shirtings and Drills; 43,000 ring spindles; 1300 looms; steam and water; W. H. Langley & Co., N. Y., s. agts. Arthur T. Smith, buyer.
- Laurens.** D-3. S. Ry. Co.; P. R. & W. C. RR.
- LAURENS COTTON MILLS;** \$350,000; W. E. (C) Lucas, pres. and treas.; W. E. Touchstone, supt.; 3 to 5 leaf Twills, Satens, etc.; 40,320 ring spindles; 188 looms; steam; Deering, Milliken & Co., N. Y., s. agts; W. E. Lucas, buyer.
- MC CORD, L. A.;** Interested in Yarn Mill (C) to be established here.
- Lexington.** D-4. S. RR.
- LEXINGTON MFG. Co.;** \$50,000; W. P. (C) Roof, pres.; Allen Jones, sec. and treas.; L. W. Redd, supt.; S. oz. Red Tickings, 3,800 ring spindles; 204 looms; water and steam; dye; H. J. Farber, Drewry & Co., s. agts.; W. P. Roof and L. W. Redd, buyers.
- Liberty.** C-3. Sou. Ry.
- LIBERTY COTTON MILLS;** \$100,000; J. P. (C) Smith, pres. and treas.; Fine Sheetings and Twills; 6,000 ring spindles; 200 looms; steam.
- Lockhart.** C-4. S. Ry. Co.
- LOCKHART MILLS;** \$650,000; Jno. C. Cary, (C) pres. and treas.; W. H. Williams, supt.; Brown Sheetings; 25,000 spindles; 800 looms; water and steam; Deering, Milliken & Co., N. Y., s. agts.; Jno. C. Cary, buyer.
- Lolo.** C-3. RR station, Spartanburg, Sou. Ry.
- VALLEY FALLS MFG. Co.;** \$100,000; S. W. (C) Scruggs, pres. and treas.; Brown Sheetings; 7,000 ring spindles; 200 looms; water.
- Manning.** E-6. A. C. L. RR.
- HARVIN, W. SCOTT;** \$13,000; Jno. (K) Meier, supt.; Men's, Misses' and Ladies' Hosiery in fast blacks and tans; 90 knitting machines; 10 loopers; steam; dye; sell direct; W. Scott Harvin, buyer.
- Marion.** D-6. A. C. L. RR.
- ASHBY COTTON MILLS;** T. Ashby Blythe; (C) Jos. J. Bradley, supt.; Yarns, Skein Warps and Cones (all Ply); 3000 spindles; steam; R. A. Blythe, Phila, s. agt.
- McColl.** C-6. C. F. & Y. V. RR.
- ICEMAN MILLS;** \$200,000; T. B. Gibson, (C) pres. and treas.; Charles Iceman, supt.; Fine Combed Yarns; 40s to 60s; 10,000 ring sp indles; steam; J. H. Lane & Co., s. agts.; Robert Chapman, buyer.
- MARIE MILLS;** \$100,000; T. B. Gibson, pres. (C) and treas.; Chas. Iceman, supt.; Hosiery Yarns; 5000 ring spindles; steam; dye; Wm. D'Olier & Co., s. agts.; Robert Chapman, buyer.
- McColl Mfg. Co.;** \$200,000; T. B. Gibson, (C) pres. and treas.; Chas. Iceman, supt.; White Hosiery Yarns; 10s to 308; 15,000 ring spindles; steam; Wm. D'Olier & Co., Phila., s. agts.; Robert Chapman, buyer.
- Munsey.**
- DAVIS COTTON MILLS, THE.** See Augusta, Ga.
- Newberry.** D-4. S. Ry. Co.; C. N. & L. RR.
- MOLLOHON MFG. Co.;** \$200,000; Geo. W. (C) Sumner, pres. and treas.; E. B. Wilbur, gen'l mgr.; Fine White Fancy Goods; 11,000 spindles; 300 looms; steam.
- NEWBERRY COTTON MILLS;** \$400,000; T. J. (C) McCrary, pres. and treas.; J. M. Davis, supt.; Brown Sheetings and Drills; 25,181 ring spindles; 900 looms; steam; Whitin & Collins, N. Y., s. agts; T. J. McCrary, buyer.
- NEWBERRY KNITTING MILL, THE;** \$25,000. (K) 000; W. H. Day, pres. and treas.; Edward Mueller, supt.; Men's and Ladies' Hosiery; 75 knitting machines; steam; dye; S. A. Fallon, N. Y., s. agt.; W. H. Day, buyer.
- Newry.** C-2. S. Ry. Co.
- COURTENAY MFG. Co, THE;** \$300,000 Wm. A. (C) Courtnay, pres. and treas.; Campbell Courtnay, sec.; St. John Courtnay, supt.; Sheetings, (72x80, 410x37); 19,440 ring spindles; 635 looms; steam and water; Carey, Bayne and Smith Co., N. Y. and Balto., s. agts.; Campbell Courtnay, buyer.
- Orangeburg.** E-5. S. C. & G. RR.; A. C. L. RR.
- CORNELSON, GEO. H.;** Orange Mill; J. M. (C) Hunnent, supt.; Proprietor, buyer; Warps, Twine and Rope; 5096 ring spindles; steam; Jas. E. Reynolds & Co., N. Y., s. agts.
- ORANGEBURG KNITTING MILL;** \$10,000; (K) B. H. Moss, pres.; J. L. Weeks, treas. and supt.; Hose and Half Hose; 35 knitting machines; steam; dye; sell direct and Nathan, McDavitt & Billings, s. agts. (Formerly at Bamberg, S. C.)
- ORANGEBURG MFG. Co.;** \$300,000; W. G. (C) Smith, pres. and treas.; T. J. McNeely, supt.; Sheetings for Export; 14,000 ring spindles; 400 looms; steam; Carey, Bayne & Smith Co., s. agts.; W. G. Smith, buyer.
- Pacolet.** C-3. S. Ry. Co.

- PACOLET MFG. Co.**; \$1,000,000; John H. (C) Montgomery, pres. and treas.; V. M. Montgomery, asst. treas.; M. R. Macomson, supt.; Brown Sheetings and Drills; 59,349 spindles; 292 looms; water; Deering, Milliken & Co., N. Y. and Boston s. agts.; John H. Montgomery, buyer. (Also Gainesville, Ga.)
- Pelham.** C.3. S. Ry. Co.
- PELLHAM MILLS**; \$300,000; Arthur Barn. (C & K) wett, pres.; M. C. King, treas.; S. F. Kelly, supt.; Warps and Yarns, Hosiery, Druggists' Floss, Twines, Ball Thread; 11,000 ring spindles; 100 knitting machines; water and steam; dye; Catlin & Co., N. Y., s. agts. (RR. station, Greer's.)
- Pelzer.** C.3. S. Ry. Co.
- PELZER MFG. Co.**; \$1,000,000; Ellison A. (C) Smyth, pres. and treas.; B. F. Gny, supt.; Shirtings, Sheetings and Drills; 120,000 ring spindles; 3,400 looms; steam and electric; Woodward, Baldwin & Co., N. Y. and Balto, s. agts.; J. A. Smith, Jr., buyer.
- Piedmont.** C.3. S. Ry. Co.
- PIEDMONT MFG. Co.**; \$800,000; James L. (C) Orr, pres. and treas.; W. F. Walker, supt.; President, buyer; Sheetings and Drills and Yarns, 8 to 12, 2, 3 and 4 ply; 61,628 ring spindles; 1994 looms; steam and water; Woodward, Baldwin & Co., N. Y. and Balto., s. agts.; Jas. L. Orr, buyer.
- Reedy River Factory.** C.3. S. Ry. Co.; P. R. & W. C. RR.; C. K. & W. RR.
- REEDY RIVER MFG. Co.**; \$134,000; (Paid in); C. W. E. Beattie, pres. and treas.; J. E. Tice, supt.; Sheetings and Drills; 12,360 ring spindles; 372 looms; water; Deering, Milliken Co., N. Y., s. agts.; W. E. Beattie, buyer. (P. O. address Greenville.)
- Rock Hill.** C.4. O. R. & C. RR.; S. Ry. Co.
- ARCADE COTTON MILLS (inc.)**; \$100,000; (C) R. T. Fewell, pres. and treas.; G. A. Buchanan, supt.; Print Cloths; 6000 spindles; 314 looms; steam; J. E. Reynolds & Co.; N. Y. s. agts. R. T. Fewell, buyer.
- CHICORA COTTON MILLS**; (re-organiza- C tion Crescent Cotton Mills); L. S. Cohen, pres.; S. Friedham, sec; W. D. Neal, supt.; Sheetings and Shirtings; 8,500 spindles; 192 looms; steam.
- FEWELL, R. T.**; Felt and Commercial (C) Hats, utilizing cotton waste. (May make shoe laces later.)
- HIGHLAND PARK MFG. Co.**; Mill No. 2; (C) C. H. Branson, supt.; Staple and Fancy Gingham; 7,500 ring spindles; 786 looms; steam; dye; sell direct. See Charlotte, N. C.
- MANCHESTER COTTON MILLS**; \$250,000; (C) J. R. Barron, pres. and treas.; W. W. Moore, supt.; Brown Cotton Goods and Yarns, 20 to 40 s, single and two ply; 18,240 ring spindles; 300 looms; H. J. Farber, Drewry & Co., s. agts.; J. R. Barron, buyer.
- VICTORIA COTTON MILL**; \$60,000; (inc. (C) '98); J. R. London, pres.; John A. Shinn, agt; Gingham and Chambrays; 7000 spindles; 272 looms; steam; dye; Hunter Mfg. & Com. Co., s. agts; J. R. London, buyer.
- Seneca.** C.2. S. RR.
- SENECA COTTON MILLS**; \$300,000; L. W. (C) Jordan, pres. and treas; E. K. Lewis, sec.; M. O. Alexander, supt.; 64 x 56 Sheetings; 17,264 ring spindles; 432 looms; steam and electricity; Carey, Bayne & Smith Co., s. agts.; L. W. Jordan, buyer.
- Spartanburg.** C.3. S. Ry. Co.; P. R. & W. C. RR.
- ARKWRIGHT MILLS**; \$200,000; R. Z. Cates, (C) pres. and treas; K. McGowan, supt.; Drills and Sheetings; 20,000 ring spindles; 70 sets; 604 looms; steam; Woodward, Baldwin & Co, N. Y., s. agts.; K. McGowan, buyer.
- BEAUMONT MFG. Co.**; \$100,000; J. H. Sloan, (C) pres. and treas.; D. L. Jennings, sec. and mgr.; J. D. Lokey, supt.; Twines and Carpet Warps; 3888 spindles; steam; dye; Jas. E. Reynolds & Co., N. Y., s. agts.; D. L. Jennings buyer.
- DRAYTON MILLS Co.**; \$250,000; A. B. Cal- (C) vert, M. F. Floyd and W. A. Law, S. M. Milliken (N. Y.), E. F. Green (Boston, Mass.), interested. *Proposed.*
- SAXON MILLS**; \$200,000; Jno. A. Law, (C) pres. and treas; L. E. Castor, sec.; J. T. Moreland, supt; 64x64 Print Cloths; 12,544 ring spindles; 300 looms; steam; Woodward, Baldwin & Co., s. agts; Jno. A. Law, buyer.
- SPARTAN MILLS**; \$1,000,000; John H. Mont- (C) gomery, pres. and treas.; W. S. Montgomery, asst. treas; W. J. Britton, supt.; Print Cloth and Sheetings; 75,000 ring spindles; 2458 looms; steam; Deering, Milliken & Co., N. Y., s. agts.; W. J. Britton, buyer.
- Sumter.** D.5. C. S. & N. RR.; A. C. L. RR.; So. Ry.
- SUMTER COTTON MILLS**; \$42,800; R. M. (C) Wallace, pres. and treas.; Abraham Moses, sec. and buyer; D. Jas. Winn, supt.; Cotton Yarn in Skeins, 10 and 12, 2 and 3 ply; 400 spindles; steam; sell direct.
- Tucapau.** C.3. S. Ry. Co.
- TUCAPAU MILLS Co.**; \$269,000; J. F. Cleave- (C) land, pres.; T. E. Moore, treas; Alf. Moore, supt.; Print Cloths; 30,114 spindles; 840 looms; water and steam; Deering, Milliken & Co., N. Y. s. agts; T. E. Moore, buyer. (RR. Station, Wellford.)
- Union.** C.4. S. Ry. Co.
- AETNA COTTON MILLS**; \$200,000; W. H. (C) Sarter, pres. and treas.; J. E. Shaw, supt.; Print Cloths, 68 x 72; 10,000 ring spindles; 300 looms; steam; Fleitman & Co., N. Y. s. agts. W. H. Sarter, buyer.
- BUFFALO COTTON MILLS**; \$600,000; T. C. (C) Duncan, pres. and treas; D. R. Harriman,

## O. A. ROBBINS,

# Machinery and Equipment for

## COTTON MILLS.

PLANS AND SPECIFICATIONS FOR COTTON MILLS.

CHARLOTTE, N. C.

- gen'l mgr. and supt; Heavy Goods for Export; 45,000 ring spindles; 1500 looms; electric power; Carey, Bayne & Smith Co., s. agts.; T. C. Duncan, buyer.
- EXCELSIOR KNITTING MILLS** (Inc. (C&K 1896); \$140,000; E. Nicholson, pres; J. H. Gault, treas. and mgr.; Ladies', Men's and Misses' Hosiery and Yarns on cones, 12s, 22s, 24s, and 30s; 5,620 spindles; 250 knitting machines; steam; dye; Sutton & Co., 55 Leonard St. N. Y., s. agts.; J. H. Gault, buyer.
- MONARCH COTTON MILLS**; \$200,000; John (C A. Fant, pres. and treas.; W. T. Beatty, sec; J. S. Thomas, supt; Cotton Cloth; 14,000 spindles; 350 looms; steam; Deering, Milliken & Co, N. Y. s. agts.; J. S. Thomas, Union Cotton Mills; \$1,100,000; T. C. (C Duncan, pres. and treas.; D. R. Harriman, gen'l mgr. and supt.; Fine Sheetings; 88,000 ring spindles; 2300 looms; steam; Carey, Bayne & Smith Co, Balto. and N. Y., s. agts.; T. C. Duncan, buyer;
- Vaucluse**. E. 3. S. RR.  
**VAUCLOSE MILLS**. See Graniteville Mfg. Co, Graniteville.
- Walhalla**. C. 2. S. Ry. Co.  
**WALHALLA COTTON MILLS**; \$150,000; E. (C R. Lucas, pres. and treas; J. E. Crosby, supt; 4 yd. Sheetng. 56x60; 10,000 ring spindles; 320 looms; steam; Deering, Milliken & Co., N. Y., s. agts; E. R. Lucas, buyer.
- Walterboro**. F. 5. P. S. RR.  
**COLLETON COTTON MILLS, THE**; \$100,000; (C A. C. Shaffer, pres; F. C. Graddock, supt; 64x64-38<sup>1</sup>/<sub>2</sub> inch Goods; 5,440 ring spindles; 136 looms; Dickson & Hanna, s. agts; A. C. Shaffer, buyer.
- Warrenville**. E. 3. S. C. & G. RR.  
**WARREN MFG. CO**; (office Augusta, Ga.) (C \$500,000; E. F. Verdery, pres. and treas; W. E. Andrews, Jr., sec; Jas. J. Ward, supt; Print Cloths; 35,000 ring spindles; 900 looms; steam; Carey, Bayne & Smith Co., s. agts.; E. F. Verdery and J. J. Ward, buyers.
- Wellford**. C. 3. S. Ry. Co.  
**TUCAPAU MILLS CO**; *See Tucapau.*
- Westminster**. C. 2. Sou. Ry.  
**CHESWELL COTTON MILL CO, THE**; \$200, (C 000; W. E. Cheswell, pres., treas. and gen'l mgr; A. Zimmerman, sec.; Sheetings, Shirtings and Drills, 5 yd. to 2 yd., 30 to 37 inches; 11,000 ring spindles; 350 looms; steam; Fleitman & Co., N. Y., s. agts; Wm. E. Cheswell, buyer.
- Whitmires**. D. 4. Sea Air Line.  
**GLENN-LOWRY MFG. CO**; \$500,000; Wm. (C Coleman, pres. and treas.; R. R. Jeter, sec.; W. D. McNeill, supt.; Sheetings; 25,000 spindles; 675 looms; steam and electricity.
- Whitney**. C. 3. P. R. & W. C. RR.; S. Ry. Co.  
**WHITNEY MFG. CO.**; \$266,000; John B. (C Cleveland, pres. and treas.; E. H. Chipard, supt.; Export Goods; 20,756 ring spindles; 720 looms; steam and water; Deering, Milliken & Co., N. Y., s. agts.; John B. Cleveland, buyer. (RR. station, Spartanburg, 2 1/2 miles distant.)
- Williamston**. C. 3. Sou. Ry.  
**WILLIAMSTON MILLS**; \$200,000; Jas. P. (C Gossett, pres. and treas.; Ellison A. Smyth, vice-pres; E. Lang Anderson, sec.; 64x64 Print Cloths; 5,000 ring spindles; 150 looms; steam. (Built mill for 10,000 spindles and 300 looms.)
- Williston**. E. 4. S. C. & G. RR.  
**ROSEMARY KNITTING MILLS**; \$30,000; L. (K A. Green, pres; G. W. Green, Jr., treas. supt. and buyer; 108 and 136 needle Cotton Half Hose; 77 knitting machines; steam and water; Bacon & Co, s. agts. (Buy yarn from 10s to 12s, 1/2 and 1/2 mixed, also white.)
- Winnsboro**. D. 4. S. RR.  
**FAIRFIELD COTTON MILLS**; \$250,000; T. K. (C Elliott, pres; Jno. W. Cathcart, treas; S. B. Sargent, supt; Skein Yarn and Brown Sheetings; 12,500 ring spindles; 450 looms; steam; Woodward, Baldwin & Co., N. Y., s. agts.; J. W. Cathcart, buyer.
- Woodruff**. C. 3. C. & W. C.  
**WOODRUFF COTTON MILLS**; \$250,000; A. (C W. Smith, pres. and treas; J. B. Kilgore, sec.; G. W. Etheredge, supt.; 64x64-38 1/2-5<sup>1</sup>/<sub>2</sub> Goods; 11,000 ring spindles; 250 looms; steam; Woodward, Baldwin & Co., N. Y., s. agts.; A. W. Smith, buyer.
- Yorkville**. C. 4. C. & L. RR.; O. R. & C. RR.  
**TAYONA MILLS** (formerly Suro Cotton (C Mill Co.); Hosiery Yarns, 10's to 20's; 6,912 spindles; steam and electric; sell direct  
**YORK COTTON MILLS**; \$150,000; W. R. Car. (C roll, pres. and treas.; P. M. Grimes, sec. and supt.; Single and 2 ply Yarns; 20s to 40s; 13,264 spindles; 7000 twister spindle steam; sell direct and Thomas & Houston Phila., s. agts.

## SOUTH DAKOTA.

No map.

For explanation of abbreviations see page 66.

- Sionx Falls**. B. C. R. & N. RR.; C. & N. RR.; C. M. & St. P. RR.; G. N. RR.; I. C. RR.; M. P. RR.  
**PETTIGREW**, F. W., Est. of; R. F. Pett. (W grew, admr; 7 sets; steam; dye. *Mill idle.*
- Watertown**. B. C. R. & N. RR. C. & N. RR. G. N. R. R. M. & H. L. RR.  
**WATERTOWN TOW MILL**; Kirlin & Gray; (F I O. M. Kirlin, supt.; Flax Tow and Hemp Fibre; steam; sell direct.

## TENNESSEE.

See map on page 68.

For explanation of abbreviations see page 66.

- Athens**. B. 9. W. S. & S. Ry. Co.; N. T. & C. RR.  
**ATHENS WOOLEN MILLS**; \$75,000; W. M. (W Nixon, pres. and mgr.; Wool Filled Doekskins, Jeans; 4 sets; 110 looms; steam; dye; sell direct.  
**FISHER**, R. J.; Misses' and Children's (K Ribbed Hose, from 95 to 128 needles; 30 knitting machines; 32 ribbers; steam; R. J. Fisher, buyer.
- Bolivar**. B. 4. I. C. RR.  
**CAMPBELL & MASHBURN**; Carding; 1 (W set; water.

- Bristol.** A-12. B. E. & N. C. RR.; W. S. of S. Ry. Co.; N. & W. RR.; S. A. & O. RR.
- BRISTOL COTTON MILLS;** Bats, Warps, **C** Yarns; 2130 spindles; 21 looms; water. *Not running. For sale.*
- Cave.** B-S. N. C. & St. L. RR.
- BEKROUGHS & TAYLOR Co.** \$30,000; W. H. **(W)** Magnus, pres.; J. M. Taylor, treas.; J. B. Mason, Supt.; Lindseys, Overalls, Jeans, Cassimeres, Cassimeres, Flannels, Blankets and Pants; 3 sets; 20 looms; 40 sewing machines; water; dye and finish; sell direct. (Buy Cotton yarn, 1 and 2 ply on beams 14 and 18.)
- Chattanooga.** C-S. RR.; C. N. RR.; C. R. & C. RR.; W. S. of S. R. Co.; N. C. & St. L. RR.; Q. & C. RR.; W. & A. RR.
- CHICAMAUGA KNITTING MILLS;** \$25,000; **(K)** J. H. McReynolds, pres.; B. A. Stockard, treas.; H. T. Pope, gen'l mgr.; Ladies' Ribbed, Underwear, Summer and Winter Weights; 14 knitting machines; 9-leevers; 25 sewing machines; steam; Nathan & McDavitt, s. agts.
- EXTRACT WOOL & MERINO CO., THE;** **(W)** R. T. Heister, pres.; C. A. Raht, vice-pres.; L. W. Llewellyn, sec. and treas.; Harry Sheard, supt.; All Wool and Merino Shoddy; Garnetting a specialty; 3 cards; 2 pickers; 2 dusters; steam; dye.
- GRIFFIN, D. J.;** Batting; steam; dye. **(C)**
- RICHMOND HOSIERY MILLS;** Mill No. 3; **(K)** (formerly Mathis & Davis Co.; H. A. Garratt, supt. (Mill at East Chattanooga.) (See Rossville, Ga.)
- RICHMOND HOSIERY MILLS;** Mill No. 2; **(K)** (formerly Ocoee Hosiery Mills); W. J. Steere, supt. (See Rossville, Ga.)
- RICHMOND SPINNING Co.;** \$250,000; E. G. **(C)** Richmond, pres.; T. N. Van Dyke, treas.; J. J. Connell, supt.; Carded and Combed Peeler and Egyptian, 6s to 24s; 10,000 spindles; steam; Jas. E. Mitchell & Co., s. agts.; J. J. Connell, buyer. (Mill at East Lake.)
- VANCE COTTON MILL Co.;** \$60,000; J. C. **(C)** Vance, pres. and treas.; A. C. Cary, sec.; Cone and Tube Yarns, 2 to 10; 1500 spindles; 16 sets; steam; Edly & Street, Prov., s. agts.; J. C. Vance, buyer.
- Cleveland.** C-9. W. S. of S. Ry. Co.
- (CLEVELAND WOOLEN MILLS;** \$30,000; G. **(W)** L. Hardwick, pres.; Julius Hardwick, treas. and buyer; Jeans, Woolen Yarns, Cassimeres and Jean Pants; 4 sets; 78 looms; 125 sewing machines; steam; dye; sell direct; pres. and treas., buyers weaving and converting dept., respectively.
- Columbia.** L. & N. RR.; N. C. & St. L. RR.
- COLUMBIA COTTON MILL Co.;** \$118,325; J. **(C)** P. Street, pres.; R. G. Sparrow, treas.; Meade Friserson, gen'l mgr. and buyer; sheetings, Drills, Seamless Bags; 7,500 spindles; 200 looms; steam; dye; Putnam, Hocker & Co., Cincinnati and N. Y., Robt. McK. Jones & Co., St. Louis, McCord & Wright, Louisville, s. agts.
- Conyersville.** A-5. P. T. & A. RR.
- EASTWOOD & SONS.** See Eastwood.
- Covington.** B-3. Ill. Cent. RR.
- TIPTON COTTON MILL;** \$75,000; J. C. Boats, **(C)** pres.; Peter Fyfe, treas.; Jno. W. Gilstein, supt.; Converters Cloths, 64/60; 3,328 ring spindles; 168 looms; steam; Catlin & Co., s. agts.; P. Fyfe, buyer.
- Cumberland Gap.** A-10. L. & N. RR.; S. RR.
- KESTERSON, A. B.;** Cumberland Gap **(W)** Woolen Mills; R. H. Wright, supt.; Jeans, Flannels, Blankets, Yarns, etc.; 1 set; 7 looms; 1 knitting machine; steam and water; dye; sell direct.
- Dowelltown.** B-S. N. & N. RR.
- DOWELLTOWN WOOLEN MILL;** Allen **(W)** Wright; Rolls, Jeans and Linseys; 1 set;
- 2 looms; steam; dye; sell direct. (RR. station, Wertenon, seventeen miles.)
- Eastwood.** A-5. RR. station. Puryear, N. C. & St. L. RR.
- EASTWOOD & SONS;** \$8,000; Knitting **(W)** Yarns; 210 spindles; 1 set; 2 looms; steam.
- Elizabethton.** A-12. B. E. & N. C. RR.; E. T. & W. N. C. RR.
- TENNESSEE COTTON MILLS Co.;** \$15,000; **(C)** L. A. Briggs, pres.; F. Hill, treas.; M. E. Clarke, mgr.; W. C. Carrier, supt.; Cotton Yarns; for Tenn. Line & Twine Co.; 1700 ring spindles; steam, dye.
- TENNESSEE LINE & TWINE Co.;** \$15,000; **(C)** Geo. N. Burdick, pres.; F. Hill, treas.; M. E. Clarke, gen. mgr. and buyer; A. J. Crandall, asst. mgr.; Fish Lines, Seine Twine, Cordage and Cotton Rope; steam; dye; sell direct.
- Englewood.** C-10. M. & N. G. RR.; N. T. & C. RR.
- BRIANT BROS.;** Enrka Cotton Mills; Cotton Yarns and Carpet Warp; 140 spindles; water; sell direct. (RR. station, Athens, eight miles; Tellico Junction, two miles distant.)
- Falls City.** B-S. N. C. & St. L. RR.
- GREAT FALLS COTTON MILLS Co.;** P. O. **(C)** address, Rock Island; \$50,000; W. P. Faulkner, pres.; H. L. Walling, treas.; W. P. Faulkner, supt. and buyer; Brown Sheetting; 4000 ring spindles; 35 cards; 130 looms; water; sell direct. (RR. station, Rock Island, one mile distant.) *Also see McMinnville.*
- Fall Mills.** C-7. N. C. & St. L. RR.
- FALLS MILLS MFG. Co.;** \$17,000; H. N. **(C & W)** Lucas, pres.; J. H. Lucas, treas.; F. J. Rachielles, supt.; Wool Rolls and Cotton Yarns; 804 spindles; 1 set; water; dye; R. McK. Jones & Co., St. Louis and E. A. Burford Co., Louisville, Ky., s. agts.
- Fayetteville.** C-7. N. C. & St. L. RR.
- ELK COTTON MILLS;** \$60,000; R. D. War. **(C)** ren, pres.; H. K. Holman, vice-pres.; R. A. Rees, sec. and treas.; C. B. Bagley, gen'l mgr.; Yarns, 4s to 30s, Single and Ply; 5000 spindles; steam; sell direct and thro' agts.; R. D. Warren and C. B. Bagley, buyers.
- Harriman.** B-9. Sou. Ry.
- HARRIMAN COTTON MILL Co.;** \$50,000; **(C)** W. B. Crinkley, Vice-pres. and gen'l mgr.; J. S. Crinkley, treas.; Warp Filling and Hosiery Yarn in Chains, Warps, Skeins, Tubes or Cones; 6,500 spindles; steam; sell direct and through agts.; W. B. Crinkley, Buyer.
- Home.** A-11. W. S. of S. Ry. Co.
- HOME WOOLEN MILLS;** J. J. Gengley; **(W)** Cassimeres, Blankets, Flannels, Linseys, Jeans, 1 set; 9 looms; water; dye; sell direct. (RR. station, Afton, one mile distant.)
- Humboldt.** B-4. L. & N.; M. & O. RR.
- HUMBOLDT COTTON MILLS;** \$100,000; H. **(C)** C. Burnett, pres.; A. R. Dodson, treas.; R. L. Beare, sec.; Thos. Egan, supt.; 4 to 69 Sheetings; 5100 ring spindles; 150 looms; Robertsons, Hughes & Co., Louisville, and Jas. Freeman Brown, N. Y., s. agts.; H. C. Burnett, Buyer.
- Jackson.** B-4. I. C. RR.; M. & O. RR.; P. T. & A. RR.
- JACKSON FIBRE Co.;** \$100,000; A. F. Bemis, **(C)** pres.; S. A. Bemis, vice-pres.; J. S. Bemis, sec. and treas.; J. B. Young, supt.; Cotton Cloth for Making Bags; 21,728 spindles; 620 Draper looms; steam; Bemis Bros.' Bag Co., Boston, s. agts. (Mills at Bemis.)
- JACKSON WOOLEN MILLS;** \$60,000; Ballie **(W)** P. Cantrell, pres.; D. R. Barfield, gen'l mgr.; Clothing, Overalls, Shirts, Duck Coats and Shirts; 1 set; 110 sewing machines; steam; sell direct; Messrs Cantrell and Barfield, Buyers.

- Jefferson City.** A-H. W. S. RR.; S. Ry. Co.  
**JEFFERSON CITY WOOLEN MILLS;** \$50,000; (W) R. H. Mountcastle, pres.; C. M. Kyle, sec. and treas.; Jeans and Yarns; (Also make Overalls and Pants); 1 set; 612 mule spindles; 50 looms; 50 sewing machines; steam; dye and finish; sell direct; C. M. Kyle, buyer mill supplies; R. H. Mountcastle, piece goods. (Buy cotton warp on beams, 1 1/2 to 20 cut, plain black and fancy.)
- Jonesboro.** A-12. W. S. of S. Ry. Co.  
**JONESBORO YARN MILLS;** \$25,000; H. H. (C) Kirkpatrick, pres.; A. P. Mathes, treas.; Cotton Yarn; 3200 spindles; 32 cards; steam; Buckingham, Paulson & Co., N. Y., s. agts.; A. P. Mathes, buyer.
- Kingsport.** A-H. S. & O. RR.  
**JORDAN, C. N.** See Rotherwood.
- Knoxville.** B-10. W. S. & S. Ry. Co.; K. & A. RR.; K. C. G. & L. RR.; M. & N. G. RR.  
**BROOKSIDE MILLS;** \$1,000,000; James May; (C) nard, pres.; Justin E. Gale, treas.; W. S. Mead, sec.; Wm. T. Lang, agt. and supt.; Drills, Sheeting, Ducks and Specialties; 28,600 ring and 2100 twister spindles; 652 looms; steam; Wellington, Sears & Co., Boston, s. agts.; Wm. T. Lang, buyer. (Building Mill No. 2; to have 27,000 ring spindles; 700 looms.)
- CHAMBERLAND KNITTING MILLS;** \$25,000; (K) J. W. Brownlee, pres. and mgr.; W. M. Brownlee, treas.; Dick W. Boyd, sec.; T. J. Whitaker, vice-pres. and supt.; Ladies' Summer Vests and Heavy Suits of Cotton; lo knitting and 19 sewing machines; steam.
- KNOXVILLE COTTON MILLS CO;** \$200,000; (C) L. D. Tyson, pres.; C. T. Leonard, treas.; Hosiery Yarns; 10,000 ring spindles; steam; sell direct; L. D. Tyson, buyer.
- KNOXVILLE KNITTING MILLS CO;** \$30,000; (K) G. S. Andes, pres.; J. C. Rodgers, treas.; J. Y. Comer, supt.; Men's, Women's and Children's Egyptian Hosiery, 84 to 200 needle; 110 knitting machines; steam; sell direct; J. C. Rodgers, buyer.
- KNOXVILLE WOOLEN MILLS;** \$550,000; (C & W) E. J. Sanford, pres.; R. P. Gettys, vice-pres.; J. A. McKeldin, treas.; H. M. McKeldin, sec.; Cassimeres, Hosiery Yarns from 68 to 208, Chain Warps in 2, 3 and 4 Plys, 108 to 168; 22 sets; 600 cards; 10,000 ring and 16,000 mule spindles; 180 broad looms; steam; dye and finish; sell direct.
- PARHAM, W. T. & SONS;** Riverside (W) Woolen Mills; Jeans, Cassimeres, Blankets, Yarns, etc.; 6 sets, 3064 spindles; 131 looms; steam; dye; sell direct Mill is in So. Knoxville. (Mill at Maryville, Tenn.; removed here.)
- STANDARD KNITTING MILLS;** \$50,000; (K) E. E. McMillan, pres.; H. B. Brammer, treas.; J. T. Brownlee, sec. and gen'l mgr.; Men's Cotton Ribbed Underwear, mostly Fleeces; 26 knitting machines; 50 sewing machines; steam; dye; sell direct and Jas. Talcott, N. Y., s. agt.; J. T. Brownlee, buyer. (Buy peeler, combed Egyptian and mercerized yarns.)
- Lawrenceburg.** C-6. L. & N. RR.  
**EAGLE COTTON MILLS;** W. H. Dustin; (C) Z. V. Crook, supt.; Batting, Yarns, (18 to 108) Carpet Warps, Twine, Rope; 3,500 spindles; water; dye; sell direct; W. H. Dustin, buyer. *Burned Jan., 1902; rebuilt.*
- LAUREL HILL MILL.** See Strathmore.
- Leandro City.** B-10. S. RR.  
**DIXIE MILLS;** \$50,000; M. B. Arnstein, (K) pres.; W. H. Hornsby, treas.; F. A. Weiss, supt.; Ladies' Misses' and Men's Hosiery; Solid Colors, Black and Tan; 100 and 200 needle goods; 250 knitting machines; steam; dye; sell direct; F. A. Weiss, buyer. (Buy yarns, 108 to 308.)
- Maryville.** B-10. K. & A. RR.  
**ANCHOR WOOLEN MILLS;** R. H. Hanna; (W) Jeans, Linseys, Satinets, Flannels, Blankets and Yarns; 1 set; 15 looms; steam; dye; sell direct.
- PARHAM, W. T. & SONS.** See Knoxville.
- McMinnville.** B-8. N. C. & St. L. RR.  
**ANNIS COTTON MILLS.** (See Great Falls (C) Cotton Mills Co.)
- MOUNTAIN CITY WOOLEN MILLS;** Clay (W) Faulkner, prop.; Jeans and Satinets made into Pants; 1 set; 22 looms; 56 sewing machines; water; dye and finish; sell direct and Jno. Silvey & Co., Atlanta, Ga., s. agts. (*Mill for sale.*)
- TENNESSEE WOOLEN MILLS;** \$40,000; (W) Frank Colville, pres.; M. T. Bass, mgr, sec. and treas.; Mc. Armstrong, supt.; Jeans, Linseys and Fancy Stripes; 2 sets; 40 looms; steam and water; dye; sell direct; M. T. Bass, buyer. (Buy all warps, use cotton yarn No. 12 1/2, 1500 ends, black and white, on beams.) *To be offered for sale July 16, 1902.*
- Memphis.** C-3  
**KRETSCHMAR, J. O.** (Purchased Memphis (C) Lint Co.'s plant); Cotton Battings, Comforts, Absorbent Cotton and Medicated Gauze; steam.
- MEMPHIS COTTON MILL CO;** John John. (C) son, sec.; 14,000 spindles; 250 looms; steam. *Reported not running.*
- Nashville.** A-7. L. & N. RR.; N. C. & S. L. RR.  
**KAUFMAN, LEO & CO;** Rock City Hosiery (K) Mill; Cotton and Wool Hosiery; 225 knitting machines; steam; dye; sell direct. (Buy yarn.)
- MAY, JACOB & CO;** Lakeshore Hosiery (K) Co.; Children's Cotton and Wool Hosiery; 300 knitting machines; steam; dye and finish; Jacob May, buyer; sell direct.
- NASHVILLE HOSIERY MILLS;** \$100,000; (K) Jesse H. Thomas, pres.; J. A. Bishop, treas.; A. W. Stone, supt.; Misses' Cotton Ribbed Hosiery; 150 knitting machines; 100 ribbers; 50 loopers; steam; dye; E. M. Townsend & Co., s. agts.; J. H. McPhail, buyer.
- NASHVILLE WOOLEN MILL CO;** \$78,000; (W) Leonard Parkes, pres. and treas.; David Senior, supt.; Leonard Parkes, buyer; Kentucky Jeans and Cassimeres; 3024 spindles; 5 sets; 84 narrow and 22 broad looms; steam; dye; sell direct.
- PHOENIX COTTON MILLS;** Box 286; \$200,000; (C) A. H. Robinson, pres.; T. B. Dallas, sec. treas. and gen. mgr.; W. P. Kelley, supt.; Treasurer, buyer; Colored Cotton Goods, Twines, Rope; 18,000 ring and 2000 mule spindles; 720 looms; steam; dye; sell direct and Cooley, Turnbull & Co., N. Y., s. agts.
- TENNESSEE MFG. CO.;** Box 415; \$700,000; (C) Geo. M. Goodwin, pres. and treas.; Arthur Goodwin, mgr.; R. M. Davis, sec.; Sheetings, Shirtings, Drills, Linings, Plaids, Carpet Warp and Grain Bags; 27,000 ring and 6000 mule spindles; 1018 looms; steam; dye; sell direct.
- Newport.** B-H. S. RR.  
**BELLEVUE COTTON MILLS;** J. L. Erwid & (C) Co.; C. L. Hutcherson, supt.; Madras, Shirtings, Domets, etc.; 195 looms; steam; dye; M. Brown, Sons & Co., N. Y., s. agts. (Formerly Newport Cotton Mill.)
- Olive Hill.** C-5. Road from Savannah.  
**DE FORD, R. D., & SON;** Carding; 1 (W) picker; 1 set; water. (RR. station, Cerro Gordo.)
- Oregon.** C-7. N. C. & S. L. RR.  
**WARREN MFG. CO.;** Yarn; 576 spindles; (C) steam and water. *Not running. For sale* (RR. station, Flintville.)

**Paperville.** A-12. B. E. & N. C. RR.; W. S. S. Ry. Co.; N. & W. RR.; S. A. & O. RR.

**PAPERVILLE WOOLEN MILLS;** J. C. (W Nutty; Skein Yarns, 108 to 208; Linsey, Blankets, Flannels; 1 set; 5 looms; water; dye; sell direct. (RR. station, Bristol, 2 miles distant.)

**Pinewood.** B-6. N. C. & S. L. RR.

**GRAHAM, H. H. & T. H.;** 4-4 Sheeting, Cot. (C) ton Rope and Yarns; 245 spindles; 44 looms. (RR. station, Graham, 3 miles distant.)

**Post Oak Springs.** B-9. C. N. O. & T. P. RR.; Rockwood & Tenn. River RR.

**ROANE WOOLEN MILL;** Cassimeres, Flan. (W) nels, Blankets, Yarns; 2 sets; 5 looms; water; dye; sell direct. (RR. station, Rockford, 3 1/2 miles.) No report since 1899.

**Pulaski.** C-6. Louisville & and Nashville RR.

**McGREW, B. F.;** Sash Cord and Bagging; (C) 140 ring spindles. *Reported not running.*

**PULASKI WOOLEN MILL;** H. F. Webb; (W) Blankets, Flannel-, etc; 1 set; steam.

**Rockford.** B-10. K. & A. RR.

**ROCKFORD COTTON MILLS;** Ernest Koella, (C) sec. and treas.; White and Colored Carpet Warps, Wrapping Twine on Balls, Tubes and Cones; 4200 spindles; water; dye; sell direct.

**Rotherwood.** A-12. B. E. & N. C. RR.

**JORDAN, C. N.;** Rotherwood Woollen (W) Mills; Yarns, Jeans, Blankets, Linsey-, etc; 1 set; 240 mule spindles; 5 looms; water; dye; sell direct. (RR. Station Bristol, 25 miles distant.)

**Shelbyville.** B-7. N. C. & S. L. RR.

**SYLVAN COTTON MILLS;** \$36,000; Wm. Mc. (C) Gill, pres.; W. J. McGill, treas.; Sheeting,

Shirting, Drills, Batting; 2720 spindles; 104 looms; steam and water; R. McK. Jones & Co., St. Louis, s. agts.; W. J. McGill, buyer.

**WILHOITE, W. L.;** Hosiery or Knit (K) Goods, Company p oposed with capital stock \$10,000. *Individually postponed.*

**Strathmore.** B-6. L. & N. RR.

**DUSTIN, W. H. & SON;** T. W. Williams, (C) supt.; Carpet Warps, Yarns, Mop Yarn and Twines; 2500 spindles; steam and water; sell direct; W. H. Dustin, buyer. (RR. station, Napier.)

**Sweetwater.** B-9. W. S. of S. Ry. Co.

**MASCOT KNITTING MILLS;** \$21,000; W. L. (K) Magill, pres.; J. H. Patton, treas. and sec.; Coarse Cotton Half Hose, 96-knitting machines; 18 ribbers; 14 loopers; steam; sell direct; W. M. Patton, buyer. (Buy No. 6 to No. 26 colored and white yarn.)

**SWEETWATER WOOLEN MILLS;** \$100,000; (W) John M. Jones, pres.; F. A. Carter, treas. and buyer; Jeans; 7 sets; 180 looms; 3600 mule spindles; steam; dye; sell direct. (Buy 12 1/2 cotton warp yarns.)

**Trenton.** B-4. M. & O. RR.

**TRENTON COTTON MILLS;** \$80,000; J. A. (C) Landis, pres.; Geo. Everett, treas. and supt.; Drills, Sheatings, Shirtings, Batting; 6000 ring spindles; 160 looms; steam; sell direct.

**Vale Mills.** C-6. L. & N. RR.

**VALE MILLS.** *See B. E. McGrew, Pulaski.*

**Winchester.** C-7. N. C. & S. L. RR.

**TOWNS CREEK WOOLEN MILLS;** R. B. (W) White, treas. and gen'l. mgr; supt; Jeans, Yarn, etc; 2 sets; 20 looms; water. *Burned March, '91. Not yet rebuilt.* (Considering project of building a knitting mill instead.)

## TEXAS.

No map.

For explanation of abbreviations see page 66.

**Austin.** A. & N. RR.; H. & T. C. RR.; I. & G. N. RR.

**SOUTHERN BEDDING MFG. CO.;** 901 E. 4th (C) St.; Mattress Stock.

**Belton.** A. T. & S. F. RR.; M. K. & T. RR.

**BELTON COTTON MILLS;** \$100,000; T. W. (C) Cochran, pres.; Peter Hammersmith, treas.; Jas. Ferguson, sec; Thos. E. Mitchell, gen'l mgr. and supt.; 4 yd. Sheeting; 3,121 spindles; 100 looms; steam.

**Bonham.** T. & P. RR.

**BONHAM COTTON MILLS;** \$150,000; Hugh (C) Hallsell, pres.; J. C. Saunders, treas. and mgr; T. L. Clark, supt; 4 yd., 36 in. 38 1/2 in. 38, 40 in. 3-60 sheeting; 5,000 ring spindles; 272 looms; steam; J. Spencer Turner Co., s. agts.; J. C. Saunders, buyer.

**Brenham.** A. T. & S. F. RR.; H. & T. C. RR.

**BRENHAM COTTON MILL;** \$150,000; 5,000 (C) spindles; 150 looms; D. C. Giddings, Jr., interested. *Proposed.*

**Celeste.** A. T. & S. F. RR.; M. K. & T. RR.

**CELESTE COTTON MILL;** \$60,000; J. T. (C) Harrell, pres.; R. D. Scates, sec.; R. W. Willey, supt.; Yarns, 208 to 408; 5000 spindles; steam; J. T. Harrell, buyer.

**Coriscana.** H. & T. Cen; St. L. S. W. RR.

**CORSICANA COTTON FACTORY;** \$150,000; (C) Geo. T. Jester, pres.; J. W. Edens, treas.; John Taylor, supt; Sheatings, Drills and Duck; 2,000 ring spindles; 150 looms; steam; sell direct.

**Cuero.** S. A. & A. P. RR.; S. P. RR.

**CUERO COTTON MILL;** \$100,000; J. A. (C) Graves, pres.; P. H. Caldwell, sec. and treas.; Ed. Soehle, supt; Brown Sheatings; 5000 ring spindles; 160 looms; electricity.

**CUERO HOSEIERY MFG. CO.;** Burgoyne (K) Fish, mgr; Gent's Half Hose and Ladies' Hosiery; 5 knitting machines; dye; sell direct.

**EXCELSIOR MFG. CO.;** \$50,000; C. L. (C) Stadler, pres.; E. Muegge, treas.; Duck, Knitting Yarn, Drilling, Sheeting; 1224 spindles; 20 looms; steam; sell direct. *Not running.*

**HENRIKH, GUSTAV;** Silk and Woolen (K) Mitts and Hosiery; 4 knitting machines; 2 sewing machines; electric; sell direct.

**Dallas.** A. T. & S. F. RR.; H. & T. C. RR.; M. K. & T. RR.; T. & P. RR.; T. R. RR.

**DALLAS COTTON MILLS;** \$275,000; T. King, (C) Boston, Mass., pres.; J. T. Howard, treas.; H. W. Fairbanks, supt; J. T. Howard and H. W. Fairbanks, buyers; 7, 8, 9 and 10 oz. Ducks; 12,000 ring spindles; 260 looms; steam; sell direct and Robinson-Hughes Co., Louisville, s. agts.

**NEW CENTURY COTTON MILLS;** \$40,000; (C) J. E. Wiley, mgr; Cotton Yarns; 2,500 spindles; steam. *Machinery ordered. Expect to start in Oct.*

**Del Rio.** S. & P. RR.

**KELLER & VAN DUKEER;** Blankets, Sad-  
dle Blankets, Specialty (33 x 60 in. from 4

to 6 lbs.); 1 set; 3 looms; 1 picker; 1 duster; 1 twister; 1 spooler; finish.

**Denison.** II, & T. C. RR.; M. K. & T. RR.

AMERICAN COTTON SPINNING CO. \$200,000; (C) W. B. Munson, pres; L. J. Tonkin, vice-pres.; Theo. F. Snyder, sec. and treas.; Yarns, 8s to 40s; 15,500 spindles; steam; Catlin & Co., Boston and N. Y., s. agts. *Not running May, '02.*

GATE CITY HOSIERY MILLS; \$20,000; W. (K) A. Tibbs, pres.; J. T. Munson, vice-pres.; F. Kohtfeldt, sec.; H. Brooks, treas.; E. P. Anll, supt.; Seamless Cotton Hosiery; 60 knitting machines; steam; dye; sell direct. (Formerly at Atlanta, Ga.) (Buy white cone cotton yarns, from 11 to 26 and 40 splicing.)

**Galveston.** A. T. & S. F. RR.; G. & W. RR.; I. & G. N. RR.

GALVESTON BAGGING & CORDAGE CO.; (J) \$250,000 (paid in); B. Adoue, pres.; Waters S. Davis, Jr., sec. and treas.; Jute Bagging; 50 looms; steam; sell direct.

GALVESTON CITY COTTON MILLS; \$325,000; (C) Julius Bunge, pres; W. M. Selkirk, sec. and treas.; 19,200 ring spindles; 590 looms; steam; dye. *Not running.*

GALVESTON ROPE CO.; \$250,000; H. A. (J) Landes, vice pres; Henry Schroeder, sec.; John Sealy, treas.; Sisal Rope and Binder Twine; steam; sell direct.

**Gonzales.** Sou. Pac. RR. S. A. & A. P. RR

GONZALES COTTON MILLS, THE; \$125,000; (C) J. P. Randle, pres; J. B. Kennard, vice-pres.; C. T. Rather, treas; W. M. Fly, mgr; J. B. Meacham, supt; Sheetings; 5000 ring spindles; 150 looms; steam; W. M. Fly, buyer.

**Henderson.** I. & G. N. RR.

RISK COUNTY COTTON MILLS; \$100,000; W. (C) J. Graham, pres; Samuel Patton, sec; A. Wettermark, treas; 5,000 spindles. *Proposed. Nothing done recently.*

**Hillsboro.** M. K. & T. RR.

HILLSBORO COTTON MILL CO; \$100,000; A. (C) L. Lowrey, pres; T. E. Tomlinson, treas; S. A. Sharpe, supt; Yarns, Duck and Sheetings; 2500 ring spindles; 80 looms; steam; A. L. Lowery, buyer.

**Houston Heights.** M. K. & T. RR.

AUGUSTA MFG. CO.; (See Oriental Textile Mills).

ORIENTAL TEXTILE MILLS; \$50,000; S. E. (W) Allen, pres; Jno. S. Radford, sec., treas. and gen'l mgr.; Camel's Hair and Mohair Press Cloth, (Bradford system worsted); 4 worsted cards; 3 combs; 1152 spindles; 8 looms; steam; sell direct; Jno. L. Radford, buyer.

**Huntsville.** I. & Gt. N. RR.

STAR STATE MILL; (State Penitenti. (W&K) ary); W. M. C. Hill, agt.; Convict Goods; 18 looms; 2 knitting machines; steam; dye.

**Itasca.** M. K. & T. RR.

ITASCA COTTON MFG. CO.; \$150,000; W. H. (C) Webb, pres; J. R. Griffin, treas; M. S. Wood, sec; 36-in. 3-yl. Sheetings; 5000 ring spindles; 200 looms; steam.

**Lindale.** I. & G. N. RR.

LINDALE KNITTING MILL; J. S. Ogburn & (K) Co.; J. S. Ogburn, supt; Cotton Hosiery; 21 knitting machines; steam; sell direct.

**Paris.** T. M. RR; A. T. & S. T. RR; T. & P. RR.

PARIS TEXTILE CO; \$150,000; J. A. Varner, pres; H. H. Kirkpatrick, sec. and treas. *Project indefinitely postponed.*

**Pittsburg.** St. L. S. W. RR; S. S. & S. RR.

PITTSBURG TEXTILE MFG. CO.; \$25,000; (W) G. C. Hopkins, pres; W. C. Hargrove, treas; Cassimeres, Dress Goods, Flannels and Jeans; (also make Skirts and Trousers); 2 sets; 14 looms; 10 sewing machines; steam; dye; sell direct.

**San Antonio.** I. & G. N. RR.; M. K. & T. RR.; S. P. RR.

TEXAS HOSIERY MFG. CO.; H. H. Hoff. (K) man, pres.; F. D. Kammann, supt.; Men's Half Hose; 50 knitting machines; steam; dye; sell direct; H. H. Hoffman, buyer.

**Sherman.** II, & T. C. RR.; M. K. & T. RR.; S. L. (S. W. Ry) RR.; T. & P. RR.

SHERMAN COTTON MILL; (office at Dallas, Texas); \$100,000; J. T. Howard, pres.; H. W. Fairbanks, sec. and treas.; Seamless Grain Bags; 3000 ring spindles; 72 looms; steam; sell direct and Robinson-Ingles Co., Louisville, Ky, s. agts.; pres. and treas., buyers.

**Waco.** M. K. & T. RR.; S. L. (S. W. Ry.) RR.; S. A. & A. P. RR.; T. C. RR.; W. & N. RR.

SLAYDEN-KIRKSEY WOOLEN MILL; \$400; (W) 000; S. F. Kirksey, pres; W. J. Slayden, vice-pres; W. W. Cameron, 2d vice-pres; S. W. Slayden, treas; F. W. Lake, sec; S. F. Kirksey, supt. and buyer; Cassimeres and Worsteds; 4 sets; 100 looms; 200 sewing machines; steam; dye; sell direct. (Buy worsted 2/20, 2/30, 2/40.)

WACO COTTON MILL. *Efforts being made (C) to remodel and put plant in operation.*

WACO KNITTING MILLS; \$50,000 (\$35,000 (K) paid up); M. L. Garrett, pres.; E. Rutan, treas.; Geo. E. Knowles, supt.; Men's, Ladies' and Children's Goods (probably make yarns later); 40 knitting machines; steam; sell direct.

**Waxahachie.** M. K. & T. RR.

WAXAHACHIE COTTON MILLS; \$100,000; (C) G. W. Gibson, pres.; J. H. Miller, treas.; E. A. Du Bose, sec. and gen'l mgr.; Thos. Howarth, supt.; 7, 8, 9, 10 oz. Duck; 5,000 ring spindles; 150 looms; steam; J. Spencer Turner Co., N. Y., s. agts.; E. A. Du Bose, buyer.

**Weatherford.** A. T. & S. Fe RR.; T. & P. RR.; W. M. W. & N. RR.

AJAX TEXTILE CO.; \$50,000; G. M. Bowie, (W) pres.; C. D. Hartnett, treas.; Worsted Yarns, 10s to 20s, Single and Ply; 4 worsted cards; 4 combs; 1200 spindles; steam; sell direct. *Proposed.*

**West.** M. K. & T. RR.

WEST COTTON MILLS; \$125,000; W. H. (C) James, pres.; J. O. Jenkins, treas.; S. F. Harrill, sec. and gen'l mgr.; W. E. Tisdale, supt.; Sheetings; 4,100 mule spindles; 220 looms; steam; Putnam, Hooker & Co., Cincinnati, O., s. agts.; S. F. Harrill, buyer.

## UTAH.

No map.

For explanation of abbreviations see page 66.

**Beaver.** U. P. RR.

BEAVER WOOLEN MFG. & MILLING CO.; (W) \$40,000; M. L. Shepherd, pres.; C. D. White, treas.; J. M. Goodwin, supt.; Doeskins, Kerseys, Blankets, Flannels, Yarns, etc; 2 sets; 10 looms; 3 knitting machines; water; dye and finish; sell direct.

**Brigham.** O. S. L. RR; S. Pacific.

BRIGHAM CITY WOOLEN MILLS CO.; (W&K) James Nelson, pres.; S. N. Lee, treas.; A. A. Janson, supt. and buyer; Blankets, Linseys, Flannels, and Yarn; Hosiery and Union Suits; 1 set; 8 looms; 1 knitting



machine; water; dye; sell direct. (Buy cotton yarns.) (RR. station, Brigham.)

**Hyrum City.** U. P. RR.

**HYRUM WOOLEN MILLS;** Baron & (W & K) Housley, props; Yarns, Cloth, Batting; Hosiery and Knit Goods; 2 sets; 4 looms; 3 knitting machines; water and steam; dye; sell direct; Thos. Baron, buyer. (RR. station, Logan City Station, eight miles distant.)

**Logan.** U. P. RR.

**CACHE KNITTING WORKS;** \$25,000; J. A. (K) Hendrickson, pres; Oscar Bjerkman, sec. and treas; Elias Neilson, supt; Hosiery, Underwear and Knit Goods; 30 knitting machines; electricity; sell direct; J. A. Hendrickson, buyer.

**LOGAN KNITTING FACTORY;** Joseph E. (K) Cardon, pres.; M. J. Ballard, treas. and supt.; Underwear and Hosiery; 37 knitting machines; sell direct; J. E. Cardon, M. J. Ballard, buyers. (Buy yarns.)

**Ogden.** O. & H. S. RR.; O. Short Line; R. G. W. RR.; S. Pacific; U. Pacific.

**OGDEN KNITTING FACTORY;** Joel Ricks, (K) supt.; Union Suits, Men's, Women's and Children's, and All Kinds of Hosiery; 8 knitting machines; sell direct.

**OGDEN WOOLEN MILLS;** \$30,000; J. A. (W) Hendrickson, pres; C. W. Cross, vice-pres.; W. Farr, treas.; E. T. Woolley, sec. and mgr.; Yarns, Blankets, Linseys, Flannels, Wool Bats, etc.; 2 sets; 8 narrow and 3 broad looms; water; dye; sell direct. (Buy cotton yarns for warp, 8 to 16.)

**Orderville.** R. G. W. RR.

**O. U. O. FACTORY CO;** 1 set; 4 looms; water. *Idle. For Sale.* (RR. station, Marysville.)

**Provo City.** U. P. RR.; R. G. W. RR.

**PROVO WOOLEN MILL CO;** \$236,000; Wm. (W) B. Preston, pres.; W. E. Bassett, treas; Reed Smoot, gen'l mgr; Hugh Clayton, supt; Cassimeres, Flannels, Shawls and Blankets, 9 sets; 67 broad looms; steam and water; dye; E. D. Anderson, Chicago, s. agt.

**Salt Lake City.** R. G. W. RR.; U. P. RR.; U. C. RR.; G. S. L. & H. S. RR.

**CUTLER BROS. Co;** \$10,000; John C. Cutler, pres; H. E. Cutler, treas; Woolen and Worsted Hosiery, Knit Bathing Suits and Underwear; 25 knitting machines; steam; dye; sell direct. (Buy yarns.)

**HOME KNITTING WORKS;** J. E. Sherlock; (K) Mittens, Hosiery, Skirts, Underwear, Etc.; 15 knitting machines; steam; dye; sell direct. (Buy 2/18 and 3/18 woolen and 2/16, 3/18, 2/28, 4/12 worsted yarn.)

**LYLE, JOHN;** Salt Lake Silk Factory; Silk (S) Dress Goods, Handkerchiefs and Ties; 4 looms; hand power; sell direct.

**Springville.** R. G. W. RR.; U. P. RR.

**WHITEHEAD, JAMES, JR.;** James (W & K) Whitehead, Jr., buyer; Stocking Yarns, Tweeds, Flannels, Linseys, Weaving Yarns and Half Hose; 3 sets; 12 looms; 8 knitting machines; steam and water; dye; sell direct.

**Washington.** U. P. RR.

**RIO VIRGEN MILLS;** D. D. McArthur, (C & W) pres; Jas. G. Bleak, treas; D. H. Morris, supt; Blankets, Flannels, Linseys, Men's Wear, Sheetings, Gingham, Battings, Yarns, Overshirts, Towels, Etc; 450 cotton and 300 woolen spindles; 2 sets; 19 looms; steam and water; dye; A. F. Miles, s. agt. (RR. station Milford, Beaver Co., 110 miles.)

## VERMONT.

See map on page 274.

For explanations of abbreviations see page 66.

**Barton.** B.4. Near Newport on B. & M. Passump. Div.

**GAY, HENRY C;** Hand Spun Yarns and (W) Hand Knit Stockings and Mittens; 1 set cards; water.

**Bennington.** J.1. Bennington & Rutland RR.

**BENNINGTON KNITTING Co;** \$25,000; (K) H. C. Lindloff, pres; N. M. Puffer, treas; H. C. Lindloff, supt; Men's, Ladies' and Children's White and Colored Underwear; 4 sets; 20 knitting machines; steam and water; sell direct; H. C. Lindloff and N. M. Puffer, buyers.

**BRADFORD, H. E. & Co;** B. A. Fryer, (K) supt. and mgr; Men's and Ladies' Fine Goods; 6 sets; 1800 mule spindles; 24 knitting machines; 40 sewing machines; steam and water; dye; sell direct and Valentine & Flagler, N. Y. s. agts; L. F. Abbott and B. A. Fryer, buyers.

**COOPER CHAS;** Knitted Ribbed Anklets, (K) Cuffs and Strip Ribbing for Jean Drawers; 65 knitting machines; steam, water and electric; sell direct. (Buy carded Egyptian, 12 to 21s, combed 20s to 52s and carded Paefer, 12s to 20s.)

**COOPER MFG. Co;** \$100,000; Chas. (K) Cooper, pres; A. J. Cooper, treas; J. E. Burke, supt; Knit Goods; 8 sets; 95 knitting machines; 75 sewing machines; steam and water; dye; S. P. Burrell & Co., N. Y. s. agts. A. J. Cooper, buyer. (Buy Egyptian yarn from 14 to 35.)

**CRAWFORD & CARNEY;** Shoddy; 4 (W) cards; 2 pickers; 2 Garnett machines; steam and water.

**HOLDEN, LEONARD & Co;** Frank B. (W) Carver, supt; Fancy Dress Goods, Flannels and Suitings; 18 sets; 78 looms; steam and water; dye; sell direct; Mr. Holden, buyer. (Also New Bedford, Mass.)

**LYONS, S. C. & Bros;** Knit Under. (W & K) wear; 2 sets; 12 knitting machines; water; firm, buyers.

**ROCKWOOD, GEO. & Co;** A. Buel (K) Sibley, mgr.; White, Scarlet, Natural Wool and Camel's Hair Underwear for Men and Ladies; 6 sets; 23 knitting machines; water and steam; dye; sell direct.

**SCOTT STOCKING MILLS** formerly Lasher (K) Stocking Co.; Olin Scott, prop; Frank Lasher, supt; Wool, Worsted, Merino, and Cotton Half Hose; 60 knitting machines; steam; dye; sell direct.

**TIFFANY BROS;** E. J. Tiffany, supt. and (K) buyer; Fine Worsted and Balbriggan Underwear; 30 knitting machines; 50 sewing machines; steam and water; dye; Valentine & Flagler, N. Y. s. agts. (Buy worsted and cotton yarns.)

**VALENTINE KNITTING Co;** \$100,000; A. B. (K) Valentine, pres. and agt; (Miss) J. A. Valentine, treas; Geo. H. Jepson, supt; All Wool and Merino and Mercerized Cotton Underwear; 8 sets; 58 knitting machines; 100 sewing machines; steam and

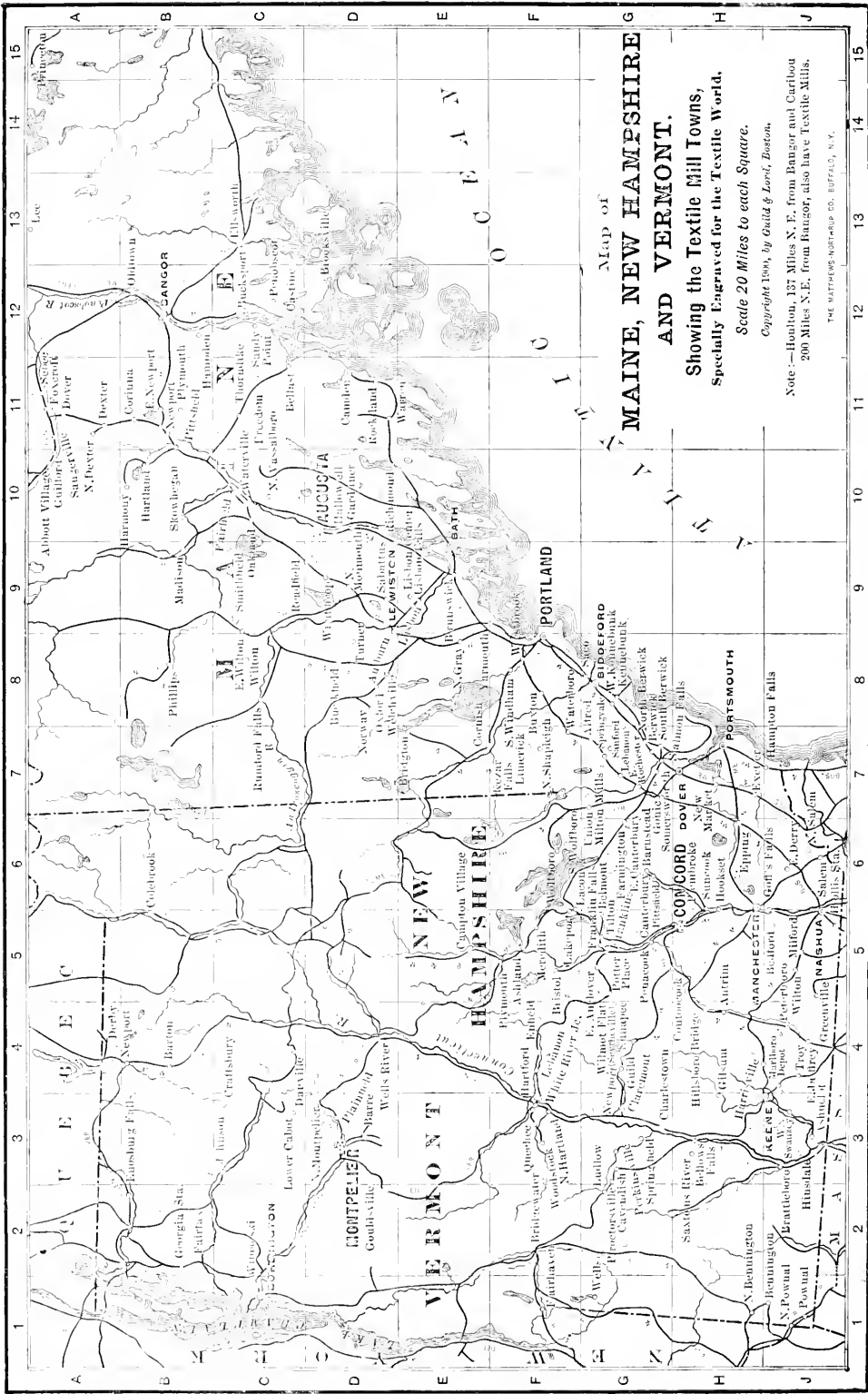

MAP OF  
**MAINE, NEW HAMPSHIRE  
 AND VERMONT.**

Showing the Textile Mill Towns,  
 Specially Engraved for the Textile World.  
 Scale 20 Miles to each Square.

Copyright 1909, by Oatka & Lord, Boston.  
 Note:—Houlton, 137 Miles N. E. from Bangor and Carleton  
 200 Miles N. E. from Bangor, also have Textile Mills.  
 THE MATHEWS-NORTHROP CO., BUFFALO, N. Y.

- water; dye; sell direct; Geo. H. Jepson, buyer. (Buy 50/2 combed Egyptian yarns.)
- Brattleboro.** J-3. Cent. Vt. and B. & M. RR, Conn. and Passump Div.
- BRATTLEBORO HOSIERY CO;** \$25,000; C. (K) H. Thompson pres; W. N. Thompson, treas.; W. D. Stockwell, supt. and buyer; Infants' and Children's Hosiery; 45 knitting machines; electricity; dye; F. Victor & Achelis, s. agts.
- MINER, CHAS. HOSIERY CO;** \$25,000; In- (K) fants' and Misses' Plated Hosiery; 30 knitting machines; steam; dye; Bacon & Co, N. Y., s. agts; Chas. Miner, buyer. (Buy 1/20, 1/35, 1/28 worsted yarn.) (Mill at West Brattleboro.)
- Bridgewater.** F-3. Woodstock RR; stage from Woodstock 6m.
- MACKENZIE, F. S;** Edw. Carpenter, supt; (W) Fine Men's Wear and Dress Goods; 6 sets; 36 looms; steam and water; dye; Deering, Milliken & Co, N. Y. and Boston, s. agts; F. S. Mackenzie, buyer.
- Burlington.** C-1. Cent. Vt. and Rutland RR.
- BURLINGTON COTTON MILLS;** \$500,000; Joel (C) H. Gates, pres; Robt. G. Severson, treas.; W. A. Trask, supt. spinning mill; Print Cloths; 14,800 ring and 15,500 mule spindles; 801 looms; steam and water; sell direct; pres. and treas. buyers.
- QUEEN CITY COTTON CO;** \$750,000; Urban (C) A. Woodbury, pres; R. A. Cooke, treas.; F. A. Shell, supt; Print Cloths; 55,008 ring spindles; 1305 looms; steam; sell direct; R. A. Cooke, buyer.
- Cavendish.** G-3. Central Vt. Rutland Div.
- GAY BROS. CO;** Cavendish Woolen Mills; (W) \$30,000; James E. Gay, treas; C. D. Gay, vice-pres., agt. and supt; Fine Satinets; 4 sets; 66 looms; steam and water; Converse, Stanton & Co, Boston and N. Y., s. agts; J. E. Gay, buyer. (Buy black and white cotton warp.)
- Craftsbury.** C-3. RR. Greensboro; St. Johns & L. C.
- HOWARD, GEO. T;** Cassimeres; 1 set; 3 (W) looms; water; dye.
- Enosburgh Falls.** B-2. Cent. Vt. RR.
- KENT, M. A;** (92 Arch St, Boston); (W & K) Missisquoi Woolen Mill; Cassimeres, Flannels, Yarns, Hosiery, Gloves and Mittens; 1 set; 5 looms; 17 knitting machines; water; dye; sell direct. *Mill idle. For Sale.*
- Fairfax.** B-2. Stage Georgia 4m. Cent. Vt. RR.
- LAMOILLE MILLS;** Mrs. H. G. Minot, agt; (W) Flannels, Blankets, Wool Wadding; 2 sets; 6 looms; water; dye. *Not running.*
- Gouldsville.** D-3. Cent. Vt. RR.
- DAVIS, C. M. & Co;** M. E. George, supt; (W) White Flannels; 7 sets; 46 looms; water and steam.
- Hartford.** F-3. Cent. Vt. RR.
- HARTFORD WOOLEN CO;** \$100,000; Eph. (W) rain W. Morris, pres; Chas. M. Cone, treas. and mgr. director; John Gruber, supt; Men's Wear, Woolens; 8 sets; 32 broad looms; 1 narrow loom; steam and water; dye; Jas. Talcott, N. Y., s. agt; C. M. Cone, buyer.
- Johnson.** C-3. St. J. & L. C. RR.
- PEARL, I. L. & Co;** Knitting Yarns, (W) Vests and Pants; 1 set; 6 looms; 10 sewing machines; water; dye; sell direct.
- Lower Cabot.** C-3. Station, Marshfield on M. & W. RR.
- HAINES, I. F;** Cabot Woolen Mill; Cas- (W) simeres and Flannels; 1 set; 4 looms; water; sell direct.
- Ludlow.** G-2. Cent. Vt. RR.
- AGAN, F. W;** W. H. Hoyle, supt; Shod. (W) dies and Wool Extracts; 6 sets; 1 garnett machine; 2 pickers; steam and water; dye; H. E. Walker, s. agt; F. W. Agan, buyer. *Will increase capacity.*
- BLACK RIVER WOOLEN CO;** \$30,000; (Inc. (W) 1891) Chas. H. Howard, pres; John E. Murch, treas; Geo. H. Levey, supt. and buyer; Overcoatings and Cloakings; 5 sets; 27 looms; steam and water; dye; Oelbermann, Dommerich & Co., N. Y., s. agts.
- LUDLOW WOOLEN MILLS;** (leased by (W) Black River Woolen Co.); Geo. H. Levey, mgr; Jas. S. Gill, supt; Overcoatings and Cloakings; 8 sets; 37 looms; steam and water; dye; Oelbermann, Dommerich & Co, N. Y., s. agts.; G. H. Levy, buyer.
- VERD MONT MILLS;** \$50,000; (\$40,000 paid (W) in); Frank W. Agan, pres.; Frank A. Walker, treas.; Chas. McDougall, supt.; Union Cassimeres, Meltons and Overcoatings; 3 sets; 48 looms; steam and water; dye; S. H. & O. B. Newhouse, N. Y., s. agts. (Buy 14, 16, 18 cotton yarn.)
- No. Hartland.** F-3. Cent. Vt. RR.
- OTTAQUEHIE WOOLEN CO;** \$50,000; (W) Horace Pease, pres; Wm. Walker supt. and buyer; Meltons; 8 sets; 60 looms; water; dye; Greeley, Cushman & Record, N. Y. and Boston, s. agts. (Buy 14 to 18 cotton yarns)
- North Montpelier.** D-3. Station Plainfield on Mont. & Wells RR.
- SIBLEY, GEO. F;** White Flannel; 3 sets; (W) 24 looms; water; Parker, Wilder & Co, N. Y. and Boston, s. agts.
- North Pownal.** J-1. B. & M. RR.
- N. POWNAL MFG. CO;** \$300,000; A. C. (C) Houghton, pres; Geo. Hopkins (No. Adams, Mass.), treas; Thos. Armstrong, supt. and buyer; 64X64 Print Cloths; 8704 ring and 10,796 mule spindles; 430 looms; water and steam; sell direct and J. M. Prendergast & Co, Boston, s. agts.
- Pownal.** J-1. Fitchburg RR.
- WRIGHTS HEALTH UNDERWEAR CO;** \$120,000; (C) S. Wright, pres; S. Wright, Jr, treas; W. D. Wright, sec.; W. A. Herman, supt.; Fleece-Lined Underwear; 8 sets; 1560 spindles; 58 knitting machines; water; S. Wright, Jr., 75 Franklin St., N. Y., s. agt. (Branch Mill at Hoboken, N. J., and Troy, N. Y.)
- Proctorsville.** G-3. Rut. RR.
- PROCTORVILLE MILLS.** Taft, Burbank (W) & Murdock; H. T. Murdock, agt.; M. J. Pierce, supt.; Union Cassimeres; 12 sets; 80 broad looms; steam and water; dye; Mackintosh, Taft & McKenney, N. Y. and Boston, s. agts.; firm, buyers.
- Quechee.** F-3. Woodstock RR.
- DEWEY CO. A. G;** \$100,000; John J. (W) Dewey, pres; W. S. Dewey, treas; V. J. Brennan, supt; Satinets; 6 sets; 48 looms; steam and water; dye; Mackintosh, Taft & McKenney, N. Y. and Boston, s. agts; pres. and treas. buyers.
- PARKER, J. C. CO.;** \$100,000; Wm. Lind. (W) sey, pres.; J. W. Parker, treas; Flannels; 7 sets; 34 broad looms; water; Faulkner, Page & Co., N. Y. and Boston, s. agts.; Wm. Lindsey and J. W. Parker, buyers.
- Saxton's River.** H-3. Electric from Bel- lows Falls, 5m Cent. Vt. RR.
- SAXTON'S RIVER WORSTED MILL;** S. L. (W) Hecht and L. Rittenberg, props; Cassi- mires and Worsteds; 4 sets; 23 looms; water; dye; S. L. Hecht & Co, N. Y., s. agts.; L. Rittenberg, buyer.
- Springfield.** G-3. Electric from Char- lestown, N. H. on B. & M. Ct. Riv. Div.
- HOLMES CO., JOHN C.;** \$30,000 (Inc. (C & D) 1892); W. S. Lovell, pres; Henry B. Holmes, treas.; Cotton Warps, All Colors on Beams and Jack Spools; 2000 ring spindles; steam and water; dye; sell direct; Henry B. Holmes, buyer.
- SLACK, W. H. H. & Bro.;** J. I. Ray. (W) mond, supt.; Shoddies; water and steam; sell direct; W. H. H. Slack, buyer.

**Wells.** G-1. Stage 3m from Granville, N. Y. on Del. & Hudson RR.

**LEWIS, R. M.;** Lake Austin Knitting (K Mills; Underwear; 1 set; 240 spindles; 4 knitting machines; 5 sewing machines; water; sell direct.

**Winooski.** C-1. Central Vt. RR.

**BURLINGTON MILLS;** (American Woolen (W Co.); Wm. M. Wood (Boston), treas.; Geo. E. Whitney, agt.; 25 sets; 300 looms; water and steam; dye; J. Clifford Woodhull, 72 Leonard St., N. Y., s. agt.

## VIRGINIA.

For explanations of abbreviations see page 66.

See map on page 82.

**Alexandria.** G-7. C. P. & O. RR.; So. Ry., Phila. W. & Balto. RR.

**ALEXANDRIA KNITTING MILLS;** Wm. S. (K Schwarzmann, pres.; J. U. Schwarzmann, treas.; S. F. Stokely, sec. and bus. mgr.; P. M. Yost, supt.; Fine Hosiery; 32 knitting machines; steam.

**Bedford City.** E-5. N. & W. RR.

**BEDFORD MILLS Co.;** \$50,000; Henry T. (W Kent, pres.; Frederic Schoff, treas.; W. C. Haberer, supt.; Army Goods, etc.; 3 sets; 26 looms; steam; dye; sell direct; Henry T. Kent, buyer.

**Berkley.** F-8. N. & S. RR.

**BERKLEY KNITTING MILLS, THE;** \$25,000; (K Geo. W. Simpson, pres.; Sam'l M. Simpson, treas.; Wm. L. Bailie, Jr. sec. and gen'l mgr.; Ladies' Cotton and Mixed Ribbed Underwear; 23 knitting machines; steam; bleach; E. M. Townsend & Co., s. agts; W. L. Bailie, Jr., buyer.

**CHESAPEAKE KNITTING MILLS;** Foster (K Black & Co.; Cotton and Mixed Underwear; 6 sets; 40 knitting and 50 sewing machines; steam; Critten, Clift & Co., N. Y., s. agts.

**ELIZABETH KNITTING MILLS;** Foster (K Black & Co.; Thos. Black, supt.; Fleece and Flat Underwear, Men's, Boys' and Children's, also dyed goods; 2000 spindles; 6 sets; 50 knitting and 50 sewing machines; steam; dye; sell direct; Thomas Black, buyer.

**Bigstone Gap.** E-1. B. S. G. RR.; L. & N. RR.; S. A. & O. RR.

**FARRAR & WHITE;** Powell River Woolen (W Mill; Cassimeres, Blankets, Jeans, Yarns; 1 set; 4 looms; dye; sell direct.

**Bonsacks.** E-4. N. & W. RR.

**BONSACK BROS.;** Blankets and Yarns; 1 (W set; 7 broad looms; steam; dye; sell direct.

**Bridgewater.** D-5.B. & O. RR.

**BRIDGEWATER MFG. Co.;** \$50,000; H. G. (W Miller, pres.; J. F. Bradburn, treas. and supt.; All-wool Blankets; 3 sets; 8 looms; water; dye; C. V. Wohlmueter, Chicago, s. agt.

**Buena Vista.** D-5. C. & O. RR.; N. & W. RR.

**BUENA VISTA WOOLEN MILLS;** McLean (W & McMurty; Jno. W. Wright, agt. and supt.; Carriage and Casket Cloths; 4 sets; 26 looms; steam; dye and finish; sell direct; C. N. McLean (2 Walker St., N. Y.), buyer. (Buy cotton warp on beams. 1/24 to 50s/2.)

**Callaway.** E-4. Ry. station, Rocky Mount, N. & W. RR. & S. RR.

**MARTIN, JAMES, A.;** 1 set cards; 4 looms; (W water; dye.

**Cedar Bluff.** E-2. N. & W. RR.

**CEDAR BLUFF WOOLEN Co.;** J. M. Mc. (W Guire, pres.; T. A. McGuire, treas.; Jno. L. Sullivan & Son, agts.; C. E. Goodwin, supt.; Cassimeres, Flannels, Blankets, Yarn; 3 sets; 14 looms; 4 knitting ma-

chines; water; dye; sell direct; T. A. McGuire, buyer.

**Charlottesville.** D-6. S. Ry. Co.; C. & O. RR.

**ARMSTRONG KNITTING Co.;** \$50,000; Jas. (K A. Armstrong, pres.; W. G. Saltzman, sec., mgr. and buyer; H. S. Becker, supt.; Children's Underwear; 10 sets knitting machinery; 60 sewing machines; steam; dye; Wm. Iselin & Co, N. Y., s. agts; buy 6s, 8s and 16s.

**CHARLOTTESVILLE WOOLEN MILLS;** (W \$200,000; H. C. Marchant, pres. and supt.; L. T. Hanckel, treas.; H. C. Marchant, buyer; Military, Letter Carrier, Police and Uniform Goods; 5 sets; 29 looms; water and electricity; dye; sell direct.

**Clifton Forge.** D-4. C. & O. RR.

**CLIFTON WOOLEN MILLS;** \$10,000; N. P. (W Foard, pres.; R. W. Foard, sec. and treas.; Cassimeres, Chevots, Jeans, Flannels and Blankets; 3 sets; 11 broad and 7 narrow looms; 2 sewing machines; steam; dye; sell direct. (Buy cotton yarn, 12 double black, 14 single black and 15 single white.)

**Danville.** F-5. S. Ry. Co.; H. & D. RR.; D. & W. RR.

**DANVILLE KNITTING MILLS;** \$25,000; (K L. Herman, pres.; F. H. Smith, sec. and treas.; Cotton Seamless Hosiery; 76 knitting machines; steam and water; dye; sell direct; H. S. Lanier, buyer.

**RIVERSIDE COTTON MILLS;** \$2,000,000; F. (C N. Burton, pres.; R. A. Schofield, sec. and treas.; S. I. Roberts, supt.; Plaids, Cheek, Stripes and Sheetings; 67,650 spindles; 2640 looms; water; dye; sell direct and N. A. Hamilton, Room 7, 34 Thomas St., N. Y., s. agt; H. R. Fitzgerald, buyer.

**Dulinsville.** C-6. S. Ry. Co.

**BERRY, H. T.;** Madison Woolen Mills; (W L. R. Woodfolk, agt; H. T. Berry, buyer; Cassimeres, Jeans, Tweeds, Linseys, Flannels, Blankets, Knitting Yarns; 1 set; 10 looms; water; dye; sell direct. (RR. station, Rapidan, 15 miles distant.) P. O. address, Port.

**Farmville.** E-6. N. & W. RR.; F. & P. RR.

**FARMVILLE HOBIERY Co.;** J. G. Burton (K Lynchburg, lessee and mgr.; Men's, Women's and Children's Hosiery; 30 knitting machines; steam; sell direct; J. G. Burton, buyer. (Formerly operated by Farmville Kig. Mills Co.)

**Fincastle.** E-4. C. & O. RR.

**AMMES, M. T.;** Fincastle Woolen Mills; (W Blankets, Flannels, Jeans, Linseys, Cassimeres, Yarns; 1 set; 3 looms; steam and water; dye; sell direct.

**Fredericksburg.** D-7. P. F. & P. RR.; R. F. & P. RR.

**MELVILLE WOOLEN Co.;** Wm. H. Duval, (W Jas. W. Good, Jr., and Jno. C. Melville; John C. Melville, supt. and buyer; Cassimeres; 3 sets; 20 looms; water; dye; Duval & Cone, s. agts.

- KLOTS THROWING Co.** (formerly Walter (S S. Stearns); Commission Silk Throwing; 15,000 spindles; steam and water; sell direct. (Also Cumberland, Md., Carbondale and Scranton, Pa.) (N. Y. office, 487 B'way).
- Fries.** (In Grayson Co.) (Not shown on map.)
- WASHINGTON MILLS;** \$2,225,000; Col. F. H. (C Fries, pres.; W. C. Ruffin, sec. and treas.; 50,000 spindles; 1300 looms; water. (Under construction.)
- Front Royal.** C. & W. RR. So. Ry.
- ROYAL TAPESTRY Co;** \$30,000; Irving A. (W Buck, pres.; Geo. P. Richards, treas.; Jos. C. Davis, supt; Covers, Curtains and Upholstery Piece Goods; 40 looms; steam; sell direct.
- Hillsboro.** B. T. S. Ry.
- GAYER, T. F;** Blankets, Yarns, Woolen (W Goods; also Rag Carpets; 1 set; 1 looms; water.
- Lambert's Point.** F. S. See Norfolk.
- Laurel Mills.** C. & S. Ry. Co.
- RAPPAHANNOCK WOOLEN MILLS Co.;** (W \$18,600; S. Russell Smith, pres.; Wm. N. Smith, treas.; F. B. Dudley, supt. and buyer; Cassimeres, Kerseys and Yarns; 1 set; 7 looms; water; dye; sell direct and Tregallas, Hertel & Co, Balto, s. agts. (RR. station, Culpeper, 16 miles distant.)
- Lynchburg.** E. S. Ry. Co.; N. & W. RR.; C. & O. RR.
- LYNCHBURG COTTON MILL Co.;** \$600,000; (C Max Guggenheimer, Jr., pres.; Herbert L. Moorman, treas.; Wm. Hinchliffe, supt; Herbert L. Moorman, buyer; Sheetings, Shirtings, Drills, etc.; 45,000 spindles; 1450 looms; steam; sell direct and J. Spencer Turner Co, s. agts.
- LYNCHBURG HOSIERY Co;** \$10,000; J. G. (K Burton, pres. and supt; R. M. Patton, treas; Men's and Women's Cotton Seamless Hose; 50 knitting machines; steam; dye; sell direct; J. G. Burton, buyer.
- MIDLAND HOSIERY Co;** \$65,000; Geo R. (K McAulan, pres. and treas; Fred W. Moore agt; Otto K. Nestler, supt; all kinds Worsted, Merino and Cotton, Ladies', Men's, Children's and Infants' Hosiery; 200 knitting machines; steam; dye; sell direct; office, 52 Franklin St. N. Y.; Otto K. Nestler, buyer
- VIRGINIA TEXTILE Co;** \$40,000; Fred (K H. Cone, pres.; W. D. Campbell, s. c; Men's Cotton Underwear; 1800 spindles; 4 sets; 18 knitting machines; steam; dye; Bacon & Co, N. Y. s. agts; M. C. Blackford, receiver.
- Manchester.** E. T. S. RR.; A. C. L.
- UNITED COTTON MILLS;** A. J. Bradley, (C pres. and treas.; Sheetings, Drills and Duck; 8,000 ring spindles; 250 looms; water; sell direct; A. J. Bradley, buyer.
- Monmouth.** D. 4. C. & O. RR.; B. & O. RR.
- BROWNS, R. H. & SON;** Cassimeres, (W Flannels, Blankets, Yarns; 1 set; 4 looms; water; dye; sell direct. (RR. station, Lexington, 3 miles distant.)
- Month of Wilson.** F. S. N. & W. RR.
- FIELDS & HASH MFG. Co, THE;** W. C. (W Fields, pres.; G. R. Hash, treas.; T. E. Duncan, supt; Yarns, Jeans, Cassimeres, Blankets, Kerseys, Linseys and Flannels; 1 set; 8 looms; water; dye; sell direct; G. R. Hash, buyer. (RR. station, Marion, 28 miles distant.)
- Newport News.** E. S. C. & O. RR.
- STEWART KNITTING MILL;** Reverdy (K Stewart, prop; Ladies' Ribbed Underwear; 24 knitting machines; steam; Manne & Co, 47 Leonard St. N. Y. s. agts.; Reverdy Stewart, buyer. (Buy 16 and 22 cone Peeler.)
- Norfolk.** F. S. A. & D. RR.; S. A. S. RR.; C. L. RR.; C. & O. RR.; N. Y. P. & N. RR.; N. & S. RR.; N. & O. V. RR.; N. & W. RR.; N. A. & A. RR.
- BLACK, FOSTER.** See Berkeley.
- CLIFTON HOSIERY MILLS Co;** \$25,000; (K G. W. Clougenour, pres.; J. Wilcox Jenkins, sec. and treas; Ladies' Hosiery; 50 knitting machines. (In hands of receiver April, 1902.)
- COTTON OIL & FIBRE Co;** Norfolk Mills; (C F. S. Cochran, gen'l mgr; C. J. Sweetnam, supt; Yarns; 6,120 ring spindles; electricity, dye; sell direct.
- NORFOLK KNITTING MILLS;** C. B. John (K ston; Knit Underwear; 6 sets; 2016 mule spindles; 45 knitting and 60 sewing machines; steam; dye; Wm. Iselin & Co, N. Y. s. agts.
- NORFOLK MFG. & SPINNING Co.;** \$25,000; (W E. Vance, pres.; F. M. Killam, treas; Carpet Yarns; 6 sets; 2184 cotton mule spindles; steam; sell direct; Barton Meyers, buyer. (In plant formerly operated by Powhatan Mfg. Co.)
- NORFOLK SILK Co;** \$40,000; Otto And. (S repp, Jr. (N. Y.) pres.; H. A. Van Liew, (N. Y.) treas; E. Goldsmith, supt; Broad Plain Silks; 325 looms; steam; Wm. Schroeder & Co, N. Y. s. agts.
- VIRGINIA HOSIERY MILLS;** A. N. Bowl (K ing, pres; W. F. Bowling, treas; W. A. Smith, supt; Misses' Ribbed Hosiery and Ladies' Hose; 120 knitting machines; steam; sell through agts; W. F. Bowling, buyer. (In hands of receiver, T. H. Wilcox, April, 1902.)
- See also Berkeley.
- Old Town.** F. S. N. & W. RR.
- GRAYSON WOOLEN MILLS;** Wm. M. Gor (W don; Linseys, Blankets, Yarns, Jeans; 1 set; 5 looms; 1 knitting machine; water; dye and finish; sell direct. (RR. station, Chestnut Yard).
- Oympia.** E. S. N. & W. RR.
- RIGGLES, W. B. & W. F;** (formerly (W J. B. Whitehead & Co); Jeans, Cassimeres, Kerseys, Yarns, Flannels, Blankets; 1 set; 4 looms; water; dye and finish; sell direct. (RR. station, Marion).
- Petersburg.** E. T. N. & W. RR.; A. C. L. RR.
- BLUE RIDGE COTTON MILL;** \$25,000; (C Augustus Wright, pres; E. G. Davis, sec. and treas.; Sheetings, Drills and Ducks; 3024 spindles; 94 looms; water; sell direct; E. G. Davis, buyer.
- ETTRICK MFG. Co.;** \$200,000; C. P. E. Bur (C gog, pres.; David Callender, treas. and agt.; W. H. Wheary, supt; Sheetings, Drills, Osnaburgs and Ducks; 9184 spindles; 262 looms; steam and water; Haines & Bishop, N. Y. s. agts.
- MATOGA MFG. Co.;** \$231,700; Chas. Hall (C Davis, pres.; E. G. Davis, treas. and agt.; Jno. M. Horton, supt.; Sheetings, Drills, Ducks and Triets; 8365 ring and 3224 mule spindles; 330 looms; steam and water; sell direct and through agts.; E. G. Davis, buyer.
- PETERSBURG HOSIERY Co;** A. S. Reinach (K & Son; S. A. Reinach, supt; Misses' 1-1 Rib (black), and Ladies' (mixed) Hosiery; 100 knitting machines; 2 sewing machines; steam and electric; sell direct and Bosser, Pere & Fils, N. Y. and H. J. Farber, Drewry & Co., Balto. s. agts; A. S. Reinach, buyer.
- POCAHONTAS MILLS;** \$50,000; E. A. Hart (C ley, pres.; R. A. Harrison, treas.; W. L. Robinson, supt.; Sheetings, Osnaburgs, Drills and Ducks; 7000 spindles; 186 looms; steam and water; Catlin & Co., Boston, and N. Y. s. agts; E. A. Hartley, buyer.
- QUINN MFG. Co., THE;** M. W. Quinn, (C Amesbury, Mass.), pres; F. J. Quinn, treas.; Yarns and Sheetings; 5000 ring spindles; 150 looms; steam and water. *For salt.*

STEARNS, JOHN N. & Co.; (N. Y. office 68 (S Greene St.); Throwing Silks; 15,000 spindles; steam and water; sell direct. Also at Williamsport, Pa, and Elmira, N. Y.

**Portsmouth.** F.S. S. A. L. RR.; N. Y. P. & N. RR.; C. & O. RR. Sou. Ry.; A. C. L. RR.

PARKER, JOSEPH A.; Misses' and Children's Ribbed Hose; 60 knitting machines; steam; sell direct; J. A. Parker, buyer. (Buys cones 8 to 30.)

PIEDMONT MFG. CO.; L. B. Whatley, (K) pres.; N. E. Whitehurst, Jr., sec. and treas.; Ladies' Misses' and Children's Underwear.

PORTSMOUTH KNITTING MILLS; \$30,000; (K) Franklin D. Hill, pres.; A. B. Butt, treas.; R. S. Mackan, act. supt.; Knit Underwear and Overshirts; 1890 spindles; 6 sets; 43 knitting and 70 sewing machines; steam; dye; W. H. Burgess & Co., N. Y., s. agts.; R. S. Mackan, buyer. (Buy white cones, 22, 14 and 7.)

**Radford.** E. 3. N. & W. RR.

RADEFORD WOOLEN MFG. CO. (Inc.); Fred (W) Canisteo, sec. and treas.; Cassimeres, Chevots, Flannels, Blankets, Yarn, Rolls and Batting; also Custom Work; 2 sets; 586 spindles; 5 looms; steam; dye; sell direct.

**Richmond.** E. 7. Atlantic Coast Line, RR; C. & O. RR. R. F. & P. RR; S. RR.

See Manchester.

**Roanoke.** E. 4. N. & W. RR.

ROANOKE COTTON MILLS; \$100,000; R. R. (C) Fairfax, pres; E. L. Stone, treas; F. B. McElwee, gen'l mgr; Warps and Twines; 5,000 ring spindles; steam; Travers Bros., N. Y., s. agts.; F. B. Elwee, buyer.

**Salem.** E. 4. N. & W. RR.

HOLSTEIN WOOLEN CO.; \$118,000; J. M. (W) Edwards (33 Wall St, N. Y.), pres. and treas.; E. M. Worden, supt. and buyer; Cassimeres; 2 sets; 20 broad looms; steam; dye; sell direct. (Buy 2/14 and 2/20 cotton yarn.)

**Snowville.** E. 4. See Radford.

**So. Boston.** E. 5. Sou. Ry.

CENTURY COTTON MILLS; \$60,000; T. S. (C) Wilson, pres. and treas.; F. A. Lukin, supt.; White Hosiery Yarns, 98 to 268; 3,000 ring spindles; steam; sell direct; T. S. Nelson, buyer.

**Suffolk.** F.S. N. & W. RR.; A. & D. RR.; A. C. L. RR.; S. A. L. RR.; S. & C. RR.

SUFFOLK DYE WORKS; J. S. Schneider, (D) prop.; Fast Black and Tans on Cotton Hose; steam. *Burned March, '02.*

SUFFOLK KNITTING MILLS; A. H. and (K) W. E. Cobb; Cotton Seamless Half Hose; 130 knitting and 20 sewing machines; steam; dye; sell direct. (Buy white yarns only.)

**Vaughn.** F. 4. N. & W. RR.

VAUGHN BROS. & Co.; Blankets, Flannels, Jeans, Linseys, Cassimeres, Yarn and Rolls; 3 sets; 13 looms; water; dye; sell direct. (Buy cotton warps, 10 to 16.) (Nearest station Sylvanus.)

**Williamsburg.** E. S. C. & O. RR.

WILLIAMSBURG KNITTING MILL CO. \$50,- (K) Hugh S. Bird, pres.; T. H. Geddy, treas.; H. S. Becker, supt.; Fleece Lined Underwear and Balbriggans; 25 knitting machines; steam; E. M. Townsend & Co., s. agts.

**Winchester.** B. 6. B. & O. RR.; C. V. RR.

BROOKLAND MILLS; John Griffith; Cas. (W) simeres and Penitentiary Goods; 2 sets; 5 looms; steam and water; dye; sell direct; J. Griffith, Winchester, buyer; (buy yarns.)

JONES, LEWIS, KNITTING CO.; \$45,000; (K) Lewis Jones, pres.; Albert Baker, treas.; Jos. W. Leafe, sec.; Arthur Leafe, supt.; Cotton Ribbed Underwear and Hosiery; 150 knitting machines; steam; dye; H. J. Farren, Phila, s. agt; Arthur Leafe, buyer. (See also Bruns-wick, Md.)

VIRGINIA WOOLEN CO.; \$25,000; W. H. (W) Crawford, pres.; Shirley Carter, treas.; Thos. L. Dunn, mgr.; Cassimeres; 2 sets; 16 looms; steam; dye; sell direct.

WINCHESTER WOOLEN MILLS; C. A. Wil. (W) liams and Bros.; Chevots, Cassimeres, and Reformatory Goods; 1 set; 8 looms; steam and water; dye; sell direct. (Buy 20/2 ply cotton warps.)

**Wytheville.** E. 3. N. & W. RR.

WYTHEVILLE WOOLEN & KNITTING (W & K) MILL CO.; \$25,000; C. B. Thomas, pres.; N. B. Rhudy, treas.; Cassimeres, Blankets, Jeans, Flannels, Skirts, Yarns, Hosiery and Women's Dress Goods; 2 sets; 9 looms; 12 knitting machines; steam; dye; sell direct; N. B. Rhudy, buyer.

## WASHINGTON.

No map.

For explanation of abbreviations see page 66.

**Kirkland.** N. P. RR.

SEATTLE WOOLEN MILLS; \$50,000; Thos. (W) E. Eyanson, pres. and mgr.; H. A. Noble, treas.; E. W. Eyanson, supt.; Blankets, Flannels, Tweeds, Carriage and Indian Robes; 2 sets; 37 looms; steam; dye. (P. O. address, Seattle.)

**Seattle.** C. & P. S. RR.; G. N. RR; N. P. RR.

AUSTRALIAN-AMERICAN WOOLEN CO.; (W) \$1,250,000; R. A. Alley, local rep.; electricity; dye. *Proposed. Company being formed April, '02.*

WEBER & EDERER MFG. CO.; 312312316 (C) Second Ave., South; Andrew Weber, pres.; E. P. Ederer, vice-pres. and mgr.; J. S.

Howland, sec. and treas.; Fish Nets, Webbing and Twine.

**Tacoma.** N. P. RR.; T. & L. C. RR.; T. L. P. & C. R. RR.

DOLMAN, ALBERT; (formerly W. E. (K) Box, & Co); Plain and Rib Wool Stockings, Socks and Mitts; 10 knitting machines; (buy yarn); sell direct.

**Walla Walla.** O. Ry. & Nav. Co; W. & C. R. RR.

STATE JUTE MILL; (State Penitentiary) (J) John B. Catron, supt.; Burlaps and Grain Bags, Fleece Twine, Matting, Hop Cloth; 1056 spindles; 70 looms; steam; sell direct

## WEST VIRGINIA.

See map on page 82.

For explanation of abbreviations see page 66.

**Barnesville.** B-4. B. & O. RR.

BARNESVILLE MFG. CO, THE; \$50,000; J. (W) M. Hartley, pres; Geo. F. Carrell, mgr; James Titherington, supt; Flannels, Blankets and Yarns; 1 set; 17 looms; steam; dye; John M. Given, Pittsburg and New York, s. agt. (P. O. address, Fairmont.)

**Blaine.** B-5. W. V. C. & P. RR.

POOL BROS.; W. H. Pool, agt. and buyer; (W) Flannels and Lumbermen's Wear a Specialty; 100 spindles; 1 set; 5 looms; water; dye; sell direct.

**Bloomery.** B-6. B. & O. RR.

WILLIAMS, B. F.; (formerly L. S. Mc. (W) Bee); Blankets, 6/4 and 3/4, Linseys, Cassimeres, Flannels, Hosiery Yarn, etc.; 1 set; 288 spindles; 4 looms; steam and water; dye; sell direct. (RR. station, Paw Paw.)

**Bruceon Mills.** B-5. B. & O. RR.; P. RR.; T. K. & F. RR.

BARKLEY, LEMUEL R.; Batting Rolls; (W) Yarns, Cassimeres, Flannels, Cloth, etc; 2 sets; 5 looms; steam and water; dye; sell direct; L. R. Barkley, buyer.

**Buckhannon.** C-4. W. V. & P. RR.

BUCKHANNON WOOLEN MILLS; Parker & (W) Stockert; M. Bastible, agt; J. H. Parker, supt.; Blankets, Jeans, Flannels, Skirts and Yarns; 2 sets; 14 looms; steam; dye; sell direct; J. H. Parker, buyer. (Mill burned, Dec., '01, and rebuilt)

**Charleston.** D-2. C. C. & S. RR.; C. & O. RR.; K. & M. RR.

KANAWHA WOOLEN MILLS; \$75,000; Frank (W) Woodman, pres, and treas; S. Minsker, supt; Flannels, Yarns and Blankets; 3 sets; 28 looms; steam; dye; Putnam, Hooker & Co, Cincinnati, s. agts; Geo. Minsker, buyer.

**Clarksburg.** B-4. B. & O. RR.; M. R. RR.; W. V. & P. RR.

CLARKSBURG WOOLEN MILL; R. T. (W) Lowhides; 3 sets; 14 broad and 10 narrow looms; steam; dye and finish; sell direct. *Mill destroyed by fire 1901, not rebuilt.*

**Evansville.** B-4. B. & O. RR.

BAKER, J. N. (formerly C. K. Bowman); (W) Skirts, Flannels, Cassimeres, Blankets, Jeans and Yarns; 1 set; 7 looms; steam; dye; sell direct. (RR station, Thornton, 6 miles distant.)

**Guseman.** B-5. RR. station Terra Alta; B. & O. RR.

ENGLEHART, JOHN; Jesse M. Englehart, (W) supt; Flannels, Blankets, Skirts, Yarns; 1 set; 300 mule spindles; 10 looms; steam; dye; R. S. Price, Chicago; W. A. Kelly, Omaha, Neb.; E. R. Gardner, Pittsburg, s. agts; Jesse M. Englehart, buyer.

**Guyandotte.** C-2. C. & O. RR.; H. & B. S. RR. O. R. RR.

STEWART, V. & B; Guyandotte (W & K) Woolen and Knitting Mills; Jeans, Yarns, Flannels, Blankets, Woolen and Cotton Hosiery, Skirting; 2 sets; 480 ring spindles; 14 looms; 20 knitting machines; steam; dye and finish; sell direct. (Buy knitting yarns 8 to 20 and blanket warp in skeins.)

**Hollywood.** E-4. C. & O. RR.

HOLLYWOOD MFG. CO.; V. S. Van (W & K) degif, supt, and buyer; Flannels, Cassimeres, Blankets, Hosiery and Yarn; 1 set; 3 looms; 2 knitting machines; water; dye; sell direct. (RR. station, Ronceverte.)

**Hundred.** B-4. B. & O. R. R.

BARTRUG & MOORE; Woolems; 1 set; 3 (W) looms; dye.

**Keyser.** B-5. B. & O. RR.; W. V. C. & P. RR.

SCHERR, A. C.; Keyser Woolen Mill. *Out of business.*

**Martin.** B-5. B. & O. RR.; W. V. C. & P. RR.

BILLMYRE, J. C.; Thorn Run Factory; (W) Blankets, Satinets, Flannel and Stocking Yarn; 1 set; 3 looms; water; dye; sell direct. (RR. station, Keyser, 20 miles distant.)

**Martinsburg.** B-6. B. & O. RR.; C. V. RR.

CRAWFORD WOOLEN CO.; \$50,000; W. H. (W) Crawford, (New York), pres.; F. M. Crawford, treas.; T. L. Dunn, supt. and buyer; Cassimeres; 2400 spindles; 6 sets; 50 looms; steam; dye; sell direct.

KILBOURN KNITTING MACHINE CO; \$250,000; E. E. Kilbourn, pres; C. W. Kilbourn, vice-pres; W. H. Everson, treas; G. W. F. Mulliss, agt; Seamless Hosiery, Merino, Worsted and Cotton; 1280 spindles; 2 sets; 200 knitting machines; steam; dye; Hinchman, Vezin & Co, N. Y., s. agts. (Office and Machine Shops at New Brunswick, N. J.)

MARTINSBURG WORSTED & CASSIMERE (W) CO; \$15,000; W. H. Crawford, (N. Y.) treas.; T. L. Dunn, treas, and supt; High Grade Worsteds and Cassimeres; 20 looms; steam; Crawford Woolen Co, s. agts.

MIDDLESEX KNITTING CO.; E. E. Kilbourn, pres.; C. W. Kilbourn, treas. (New Brunswick, N. J.) agt.; G. W. F. Mulliss, (Martinsburg, W. Va.) agt.; Treasurer, buyer, Seamless Hose and Half Hose, in Wool, Worsted and Cotton, Plain and Stripes; 250 knitting machines; steam; Hinchman, Vezin & Co, N. Y., s. agts. (Office at New Brunswick, N. J.)

**Maysville.** B-5.

SCHERR, A. C.; Maysville Woolen Mill. *Out of business.*

**Morgantown.** B-4. B. & O. RR.

MONONGAHELA TEXTILE CO., THE; (W) \$50,000; J. D. Sands, pres; W. K. Given, treas; Blankets, Dress and Shirt Flannels, Skirts; 4 sets; 21 broad and 8 narrow looms; steam; dye; John M. Given, Pittsburg and N. Y., s. agt; W. K. Given, buyer.

**Moundsville.** A-3. B. & O. RR.; O. R. RR.

WHEELING WEAVING MILLS CO; H. S. (C) Sands, (Wheeling, W. Va.) pres; Thos. Keyser, sec. and treas; Colored Cotton Counterpanes and Tapestry; 23 looms; steam; bleachery; sell direct; Thos. Keyser, buyer. (P. O. address care of H. S. Sands, Wheeling, W. Va.)

**Raleigh.** D-3. C. & O. RR.

SPANGLER & TURROW; Raleigh Woolen (W) Mill; C. P. Spangler, supt; Linseys, Jeans, Blankets, Yarns and Flannels; 1 set; 3 looms; water; dye and finish; sell direct. (P. O. address, Beckley.)

**Shepherdstown.** B-7. N. & W. RR.

PENSANT KNITTING CO.; Jas. Troughton, (K) pres.; Bicycle Hose, Boys' and Misses' Ribbed Hose; 480 knitting machines; steam; Jas. Troughton, buyer. (Formerly at Philadelphia.)

**Shiloh.** B-3. RR. station Sisterville; D. R. RR.

- BROWN BROS.;** Blankets, Flannels, (**W**) Yarns; 2 sets; 3 broad and 3 narrow looms; dye; sell direct.
- Terra Alta.** B-5. B. & O. RR.
- TERRA ALTA WOOLEN MILLS;** J. W. (**W**) Rigg, Son & Co.; T. J. Picking, supt.; All Wool Flannels, Blankets, Skirts, Yarns, Cassimeres, Golf Goods, etc.; 2 sets; 1,000 spindles; 15 looms; steam; dye; sell direct and C. E. Bateson & Bro., St. Louis, s. agts.; T. J. Picking, buyer.
- Webster.** B-4. B. & O. RR.
- WALTERS & FELTNER;** Walter Senior, (**W**) trustee; Flannels, Skirts, Blankets, Yarns, Etc.; 1 set; 14 looms; steam; dye; sell direct.
- Wheeling.** A-3. B. & O. RR.; O. R. RR.; P. RR.; W. & E. G. RR.; W. & L. E. RR.; W. B. & T. RR.
- STIFFEL, J. L. & SONS;** Indigo Prints and (**Pr**) Drills; 2 machines; steam; Jenkins, Kreer & Co., Chicago; Franklin Mfg. Co., N. Y. & Balto., Harry L. George, St. Joseph, Mo. and Skinner, White & Co., St. Louis, s. agts.
- WHEELING WEAVING MILLS.** See Moundsville.

## WISCONSIN.

See map on page 136.

For explanation of abbreviations see page 66.

- Albany.** G-5. C. M. & St. P. RR.
- ALBANY LINEN MILLS;** \$100,000; M. V. (**F**) Nichols, pres.; S. E. Nichols, treas. and supt.; Huckabacks, Towels, Crash Towels, Turkish Towels and Terry Cloths; 1,000 spindles; 100 looms; water and steam; M. J. Warren, 377 B'way, N. Y., s. agt.; S. E. Nichols, buyer. (Buy cotton yarns, 20/2 and 30/2, also Turkey Red cotton, 12/3 ply, etc., also some flax and tow.)
- Appleton.** E-6. C. M. & St. P. RR.; C. & N. Ry.
- APPLETON KNITTING CO.;** \$20,000; Geo. (**K**) McNamee, pres.; J. S. Rossiter, treas.; Fascinators, Shawls, Edgings, Knit Skirts; water; sell direct. (Buy worsted yarn.)
- APPLETON WOOLEN MILLS;** \$75,000; G. (**W**) C. Duffie, pres.; D. V. N. Harwood, treas.; F. J. Harwood, mgr. and buyer; Paper Maker's Felts and Jackets, Cassimeres, Yarns, Flannels; 3 sets; 1800 spindles; 14 looms; steam and water; dye; sell direct.
- FOX RIVER VALLEY KNITTING CO.;** \$50,000; (**K**) C. S. Smith, pres. and treas.; D. Notlage, sec.; John Steinborg, mgr.; Hosiery and Mittens; 30 knitting machines; steam and electricity; dye; sell direct; John Steinborg, buyer. (Buy all kinds of yarn.) *Entire stock destroyed by fire, April, 1902.*
- KOELIN, HENRY** (formerly J. K. Frit-singer); Carding; steam.
- LAKE SUPERIOR KNITTING WORKS;** \$10,- (**K**) 000; W. C. Brown, pres.; F. J. Harwood, treas.; Woolen Hosiery, Socks, Mittens and Gloves; 60 knitting machines; 2 sewing machines; water; electricity; sell direct; F. J. Harwood, buyer.
- LEVINSON, D.;** Interested in Co. to start (**W**) Rug or Knitting Mill.
- SPIERING, ADOLPH;** Flannels and (**W** & **D**) Knitting Yarn; 1 set; 3 looms; water; also dyes.
- Avalanche.** F-4. C. M. St. & P. RR.
- GLENN, ISAIAH,** Yarns and Knit (**W** & **K**) Goods; 1 set; 240 spindles; 2 knitting machines; steam; dye; sell direct. (R. R. Station Viroqua.)
- Baraboo.** F-5. C. & N. W. Ry.
- ISLAND WOOLEN CO.;** E. P. & W. H. Mc. (**W**) Fefridge, managers and buyers; F. E. Morey, supt.; Cheviots and Cassimeres; 5 sets; 1 narrow and 24 broad looms; water; dye; H. Bauendahl & Co., s. agts.
- MCARTHUR, GEO. & SON;** Baraboo Towel (**C**) Mills; G. McArthur, Jr., supt.; Turkish Towels and Crashes; 30 looms; water; sell direct; G. McArthur, Sr., buyer. (Buy cotton and linen.)
- WELCH, J. H., EST. OF;** Baraboo Knitting (**K**) Works; 20 knitting machines. *Mill idle. For sale.*
- Barron.** C-3. M., St. P. & S. S. M.
- BARRON WOOLEN MILL CO.;** \$10,000; (**W**) Chas. S. Taylor, pres. and supt.; L. Taylor, treas.; Chas. S. Taylor, buyer; Flannels, Cassimeres, Dress Goods, Blankets, Mackinaws, Shawls, Yarns; 1 set; 400 spindles; 5 looms; water; dye; sell direct.
- Beaver Dam.** F-6. C. M. & St. P. RR.
- BEAVER DAM COTTON MILLS;** \$225,000; E. C. (**C**) McFebridge, pres.; John T. Smith, treas.; H. H. Jaquith, supt.; 4 yd. 56/60 Brown Sheetings; 11,300 spindles; 314 looms; steam and water; C. B. Smith, s. agt.; treas. and supt., buyers.
- BEAVER DAM WOOLEN MILLS;** \$100,000; (**W**) Edward C. McFebridge, pres.; John T. Smith, treas.; John W. Wilson, supt.; John T. Smith, buyer; Fine Wool Salting; 4 sets; 19 looms; water and steam; dye; sell direct.
- BEAVER DAM WOOLEN MFG. CO.;** \$75,000; (**W**) M. A. Jacobs, pres.; Peter Beule, treas.; Peter Pfeiffer, sec.; W. A. Harley, supt.; Fancy Cassimeres and Overcoatings; 5 sets; 27 looms; steam and water; dye and finish; H. Bauendahl & Co., s. agts. (Operate plant of Beaver Dam Woollen Co.)
- Beloit.** G-5. C. M. & S. P. RR.; C. & N. RR.
- RACINE KNITTING CO.;** Jas. P. Logic, (**K**) supt.; Cotton, Woolen, Cashmere, Worsted and Merino, Men's, Women's and Children's Seamless Hosiery; 200 knitting machines; 4 sewing machines. (See main office at Racine.) (Underwear mill at Stevens Point.)
- Burlington.** G-6. (Not shown on map.) C. M. & S. P. RR.; Wis. Cen. RR.
- BURLINGTON BLANKET CO.;** \$100,000; G. (**W**) C. Rasch, pres.; R. L. Hanson, vice-pres.; W. G. Rasch, sec.; L. J. Smith, treas.; Felted Horse Blankets, Felt Cards; no looms; steam; sell direct; G. C. Rasch, buyer.
- Cedarburg.** F-6. C. M. & St. P. RR.
- CEDARBURG WOOLEN MILLS;** \$100,000; (**W**) D. Wittenberg, pres.; J. H. Wittenberg, treas.; J. Fred Wittenberg, sec. and mgr.; Wm. Roebken, Jr., supt.; J. Fred Wittenberg, buyer; Woolen and Worsted Yarns; Blankets, Mackinaws and Flannels; 3 sets woolen, 2 sets worsted; 3 combs; 17 looms; steam and water; dye; sell direct; J. Fred Wittenberg, buyer.
- Chippewa Falls.** D-3. C. M. & St. P. RR.; W. C. RR.; C. St. P. M. & O. Ry.
- CHIPPEWA FALLS WOOLEN MILL;** French (**W**) Lumbering Co.; \$38,000; 124 Bridge St.; Chas. A. Mandelert, pres.; Chas. Mandelert, treas.; M. Wolfe, supt.; Jos. Mandelert, buyer; Kersyses, Flannels, Cassimeres and Yarns; 1 set; 4 looms; steam; dye; sell direct; C. A. Mandelert, buyer.



**Cleveland.** E-7. C. & N. RR.

HEINIG, LOUIS; Woolen Underwear, (K) Jackets and Socks; 6 knitting machines.

**Deperre.** E-6. C. M. & St. P. RR.; C. & N.W. RR.

ONEIDA KNITTING CO.; \$25,000; C. W. (K) Jackson, pres.; A. D. Race, sec. and treas.; Jos. Branson, supt.; Shawls, Skirts, Fascinators, etc.; 8 knitting machines; water.

**Eau Claire.** D-3. C. M. & St. P. RR.; C. & N. Ry.; W. C. RR.

EAU CLAIRE LINEN CO.; H. C. Putnam, (F) pres.; Geo. T. Thompson, treas.; S. S. Kepler, mgr.; J. C. Cady, supt.; S. S. Kepler, buyer; Linen Crash, Turkish Bath Towels, Terry Cloth; 224 spindles; 52 looms; water; bleach; sell direct. (Buy 20/2 and 12/1 cotton yarn.)

**Ettrick.** E-3. C. & N. Ry.

ETTRICK WOOLEN MILLS; J. J. Blue; (W) Flannels, Blankets, Tweeds, Yarns; 1 set; 4 looms; water; dye; sell direct. (RR. station Galesville, 10 miles distant.)

**Fountain City.** E-3. C. B. & N. RR.

COLEY CARPET AND RUG CO.; A. Kir. (W) schner, pres.; C. A. Kirschner, treas.; Joseph Coley, supt.; Reversible Brussels and Wilton Rugs; 3 looms; steam; W. K. Smith, s. agt.

**Franksville.** G-6. C. M. & St. P. RR.

FRANKSVILLE TOW CO.; C. F. Rammelt, (F) prop.

**Galesville.** E-3. C. & N. RR.

GALESVILLE WOOLEN MILLS; L. H. (W) Stickler, mgr.; Knitting Yarns, 6s to 20s, Skeins, Flannels and Blankets; 1 set; 3 looms; steam; dye; sell direct; L. H. Stickler, buyer (Formerly at Bangor.)

**Genesee Depot.** F-6. C. M. & St. P. RR.

PROCTOR, JAMES; Genesee Woolen (W) Mill; \$25,000; Knitting Yarns and Flannels; 2 sets; 1152 spindles; steam and water; dye; sell direct.

**Hammond.** D-2. C. St. P., M. & O. RR.

NORTHWESTERN TOW CO. (F)

**Janesville.** G-5. C. & N. Ry.; C. M. & St. P. RR.

BURNS, P. V. (formerly C. Bailey); (C) Cotton Batting and Mattress Stock; 25 cards; steam and water; sell direct.

JANESVILLE COTTON MILLS. *Out of business. Mill closed. Plant offered for sale.*

LEWIS KNITTING CO.; \$75,000; S. B. Lewis, (K) pres.; P. F. Lewis, treas. and supt.; S. B. Lewis, buyer; Full Fashioned Underwear; 57 knitting machines; steam; sell direct.

ROCK RIVER COTTON CO.; \$150,000; Fred C. Howe, pres.; T. O. Howe, treas.; Geo. Ashley, supt.; Cotton Batting, Mattresses, Pillows; Twine, Warp, Etc.; 2012 spindles; steam; sell direct; T. O. Howe, buyer.

ROCK RIVER WOOLEN MILLS; Jonathan (W) Ellis, prop.; W. H. Jones, supt.; Meltona; 4 sets; 28 looms; water; dye and finish; Curless & Warren, Chicago and N. Y., s. agts.

**Kenosha.** G-7. C. & N. W. Ry.

CHICAGO ROCKFORD HOSIERY CO.; \$300, (K) 000; J. J. Hoyt, pres.; C. F. Cooper, supt.; W. W. Cooper, gen. mgr. and buyer; Hosiery; 4 sets; 530 knitting machines; steam; dye; sell direct.

COOPER UNDERWEAR CO.; Henry S. (K) Cooper, supt. and buyer; Men's Fine Underwear; 12 knitting machines; steam; dye.

**La Crosse.** E-3. C. & N. Ry.; C. M. & St. P. RR.; C. B. & IL RR.; G. B. W. & St. P. RR.

BLASHER, R.; La Crosse Woolen Mills; (W) 712 South Eighth St.; Yarns, Cotton and Wool Batting, etc.; 1 set; 1 loom; steam; dye; sell direct.

LA CROSSE KNITTING WORKS; \$40,000; (K) G. R. Montague, pres.; F. W. Robbins, sec. gen. mgr. and buyer; Wool Hosiery; German Socks and Mittens; 2 sets; 825 spindles; 100 knitting machines; steam; dye; sell direct.

STAR KNITTING CO.; A. S. Farnam, mgr. (K) and buyer; Silk, Saxony and Woolen Mittens and Knit Gloves; 35 knitting machines; sell direct.

**Little Falls.** C-2. Polk Co. M. St. P. & Sault Ste. M. RR.

WINGER & WINGER; Yarn Rolls, Batting, (W) Mackinaw Blankets and Flannels; 1 set; 4 looms; water; dye; (RR. station, De ronda.)

**Mauston.** E-5. C. M. & St. P. RR.

MAUSTON WOOLEN MILLS; John M. (W) Stickler; Yarns and Flannels; 1 set; 200 spindles; 2 looms; steam; dye; sell direct.

**Menasha.** E-6. C. M. & St. P. RR.; W. C. RR.; C. & N. W. Ry.

HEWITT, W. P. & Co.; Flannels, Dress (W) Goods and Skirting; 3 sets; 19 looms; steam and water; dye; sell direct.

**Milwaukee.** F-6.

BACH, HERMAN & SON. *Out of business.*

CUBA KNITTING CO; 516 Clinton St; (K) Hulda Baassler, pres; Max Baassler, treas.; Walter Baassler, agt; Fancy Knit Goods, Sweaters, Jackets Underwear and Toques; 10 knitting machines; steam; sell direct; Hulda Baassler, buyer.

FLEISCHER, ERNST; 379 Eleventh Ave; (K) Jackets, Sweaters and Hosiery; 13 knitting machines; 1 sewing machine.

FLEISCHER, WM.; 1109 Garfield Ave.; (K) Hand Knit Jackets; 12 knitters.

FRIEDLANDER, MORRIS; 520 State St; (K) A. J. Friedlander, supt; Saxony, Wool, Cotton and Silk Mittens and Gloves; 150 knitting machines; 4 sewing machines; steam; sell direct; M. Friedlander, buyer

GEM HAMMOCK & FLY NET CO, THE; 184 (C) Hanover St., \$25,000; Wm. Kootz, pres; Chas. Knoernschild, treas; Hammocks, Nets, Etc; 29 looms; 10 sewing machines; steam; dye; sell direct; buy cotton warps and seine twine.

GREAT WESTERN KNITTING CO; 388 (K) Broadway; \$25,000; Morris Miller, pres. and treas; A. Rosenberg, supt; Hand Made and Machine Made Knit Goods, Mittens, Gloves, Shefland Shawls, Hoods, Fascinators, Toques, etc.; 50 Lamb and 5 Rachel machines; electricity; sell direct; M. Miller, buyer. (Buy yarns.)

KALAMAZOO KNITTING CO; 402 Fowler (K) St; \$150,000; Carl Freshel, pres; Louis Heilbrunner, treas; Edw. Freshel, supt; 4 sets; 300 knitting machines; steam; dye; sell direct; Carl Freshel, buyer.

MILWAUKEE WORSTED CLOTH CO.; 31st (W) and Galena Sts.; \$80,000; Wm. H. Meyer, pres.; H. J. Millmann, sec. and treas.; John Viehs, supt.; Fine Worsted Cloths; 15 broad looms; steam; dye; sell direct; H. J. Millmann, buyer. (Buy worsted yarns from 2/20 to 2/80.)

MILWAUKEE WORSTED MILLS; \$260,000; (W) L. F. Schecker, pres.; W. H. Imbusch, treas.; H. W. Ramien, supt; L. F. Schecker, buyer; Worsted Yarns; 6 combs; (Bradford system); steam; dye; sell direct.

NATIONAL KNITTING CO.; 889 Clinton St.; (K) \$250,000; S. M. Levy, pres. and mgr.; D. Brittle, treas.; Mittens and Gloves, Leather Faced Goods; 6 sets; 600 knitting machines; steam; dye; sell direct.

PHOENIX KNITTING WORKS; 311-313 (K) Broadway; \$40,000; E. A. Button, pres;

- E. C. Mason, treas.; Herman Gardner, supt. and buyer; Mittens and Gloves, Silk, Saxony, Worsted and Woolen; 255 knitting machines; steam; sell direct.
- RAUSCHENBERGER, JOHN, Co.**; Mill at 871 (J) Teutonia Ave; store and salesroom 93-97 West Water St.; \$28,000; J. Rauschenberger, pres.; W. G. Rauschenberger, treas. and buyer; Ferd. Rauschenberger, supt.; Sisal and Hemp Twine, Hair Rope and Hair Tassels; steam; dye; sell direct.
- VAN DIKE KNITTING CO.**; 255 South (K) Water St.; Underwear; 250 knitting machines; steam; dye; sell direct.
- WISCONSIN KNITTING WORKS**, 185 (K) Second St.; \$30,000; R. Laev, pres.; Leopold Laev, treas.; J. A. Laev, supt.; Shetland Shawls, Sweaters, Cardigan Jackets, Facinators and Fancy Knit Goods; 6 knitting looms; 38 knitting machines; steam; sell direct; L. Laev, buyer. (Buy 2/24 and 2/20 worsted and wool, 3/14, 2/12 wool, 2/20-2/30, 2/32 worsted, etc.)
- Monticello**. G.5. C. M. & St. P. RR.; I. C. RR.
- MONTICELLO WOOLEN MILLS**; D. (W & K) Kennedy & Sons; Cassimeres, Flannels, Blankets, Yarns, Skirtings, Etc.; 2 sets; 7 looms; 2 knitting machines; water; dye; sell direct.
- Neenah**. E.6. C. & N. RR.; W. C. RR.
- JERSILD KNITTING CO.**; \$20,000; J. N. (K) Jersild, pres.; H. H. Clansen, treas.; H. Jersild, supt.; Knit Goods, Sweaters, Men's Cardigans, Skirts, etc.; especially Hosiery; 30 knitting machines; sell direct. (Buy worsted yarn. 20-16 cut.)
- Neshkoro**. E.5. C. & N. Ry.
- WELLS WOOLEN CO.**; \$8000; Thos. Wells, (W) pres. and treas.; Thos. Wells, Jr., supt. and buyer; Shirts, Flannels and Yarns; 1 set; 3 looms; water; dye; sell direct. (RR. station, Princeton, 10 miles distant.)
- Onalaska**. E.3. C. & N. RR., C. B. & Q. RR.
- ONALASKA MFG. CO. THE**; S. Heinbeck, (W) pres.; J. G. Aiken, vice-pres.; A. N. Moore, treas.; Woolens; 1 set; 1 picker; 10 looms; steam.
- Oshkosh**. E.6. C. M. & St. P. RR.; C. & N. RR.
- NORTHWESTERN GRASS TWINE CO.**; (J) Binder Twine, Rugs, Matting, etc; 30 machines.
- Oslo**. E.7. C. & N. RR.
- OSLO WOOLEN MILL**; Stephenson Bros; (W) Rolls and Batting; 1 set; water. (Nearest station Cato.)
- Portage**. F.5. C. M. & St. P. RR.; W. C. RR.
- PORTAGE HOSIERY CO.**; \$97,500; J. H. (K) Rogers, pres.; L. Breese, treas., agt., supt. and buyer; German Socks, Hosiery and Mittens; 1 set; 125 knitting machines; steam; dye; sell direct. (Buy worsted yarns.)
- PORTAGE UNDERWEAR MFG. CO.**; L. (K) Breese, pres.; F. P. Schumann, sec. and treas.; Ladies', Men's and Children's Underwear, Silk, Wool, Merino, Lisle and Linen; steam; dye; sell direct and Geo. B. Cramer & Bro, 943 Broadway, N. Y., s. agts.
- Prairie du Chien**. F.3. C. M. & St. P. RR.; C. B. & N. RR.
- PRAIRIE DU CHIEN WOOLEN MILL CO.**; (W) \$40,000; F. H. Pochler, pres.; J. W. Paris, sec. and treas.; R. D. Paris, mgr.; Ready Made Pants, Cassimeres, Dress Goods and Flannels; 1320 spindles; 3 sets; 14 broad and 6 narrow looms; 8 sewing machines; steam; dye; G. M. Gross & Co., Chicago, s. agts.; J. W. Paris, buyer.
- Racine**. G.7. C. M. & St. P. RR.; C. & N. Ry.
- RACINE KNITTING CO.**; \$250,000; A. J. (K) Blake, pres.; H. S. Blake, treas.; steam; dye; sell direct; Jno. W. Amend, buyer. (See mills at Beloit and Stephens Point, Wis.)
- RACINE WOOLEN MILLS**; Blake & Co.; (W) \$100,000; L. J. Elliott, pres.; Sands M. Hart, treas.; Thos. J. Corcoran, supt.; Treasurer, buyer; Shawls; 5 sets; 29 looms; 6 sewing machines; steam; dye; sell direct. (See also Ferr. Ind.)
- WISCONSIN KNITTING CO.**; 314 Main St.; (K) \$15,000; Jas. P. Logne, manager; Woolen Mittens and Gloves; 23 knitting machines; sell direct.
- Reedsburg**. F.4. C. & N. Ry.
- REEDSBURG WOOLEN MILLS Co.**; \$100, (W) 000; R. P. Perry, pres. and treas.; W. H. French, supt.; Mellons and Cassimeres; 4 sets; 32 looms; steam and water; dye; sell direct; E. E. Rockwood, 803 Medinah Temple, Chicago.
- Richland Centre**. F.4. C. M. & St. P. RR.
- BRIMMER BROS. & Co.**; Flannels, (W & K) Yarns, German Socks; 1 set; 4 broad and 2 narrow looms; 10 knitting machines; 1 sewing machine; steam; dye.
- Ripon**. E.6. C. M. & St. P. RR.; C. & N. Ry.
- RIPON KNITTING WORKS**; \$50,000; H. P. (K) Cody, pres.; J. W. Wright, treas.; Geo. Oyster, supt.; Hosiery; Gloves, Mittens; 130 knitting machines; 25 sewing machines; steam; dye; sell direct; J. W. Wright, buyer. (Buy wool yarns, 2/5 to 2/40; worsted, 2/15 to 2/36.)
- RIPON UNDERWEAR CO.**; \$25,000; Louis (K) Lynch, pres; W. A. Sisson, sec; S. M. Pedrick, treas; A. E. Schaub, supt; Jersey Ribbed Underwear; sell direct. (Buy combed, carded Peeler and combed Egyptian, also French system worsted yarn.)
- Sheboygan**. E.7. C. & N. Ry.
- SHEBOYGAN KNITTING CO.**; \$50,000; F. A. (K) Dennett, pres; H. Chesebro, treas; Edwin Ward, supt; Hosiery, Lumbermen's Knit Boots, Gloves and Mittens; 3 sets cards; 150 knitting machines; steam; dye; Mayer Bros, 47 Leonard St, N. Y., s. agts; H. Chesebro, buyer. (Buy cotton yarn. 21/2, 3s, 4s, 5s, 16s, 18s single on cones.)
- Sheboygan Falls**. E.7. C. & N. Ry.
- BRICKNER WOOLEN MILLS Co.**; \$100,000; (W) Geo. H. Brickner, pres.; W. C. Brickner, treas, supt and buyer; Flannels, Cassimeres, Dress Goods, Shawls; 6 sets; 27 looms; steam and water; dye and finish; sell direct.
- Steven's Point**. D.5. G. B. W. & St. P. RR.; Wis. Cent. RR.
- RACINE KNITTING CO.**; C. W. Hayes, (K) supt.; Full Fashioned Underwear; 25 knitting machines; 10 sewing machines. (See main office at Racine.) (Hosiery plant at Beloit.)
- Two Rivers**. E.7. C. & N. RR.; G. Trans. Co.
- TWO RIVERS KNITTING MILL**; C. W. (K) Schmidt, pres. and supt; W. S. Bremer, treas.; Sweaters, Dressing Sacks, Hosiery, Skirts, Cardigan Jackets, Tights, etc.; sell direct; both men buy.
- Waukesha**. F.6. C. M. & St. P. RR.; C. & N. W. RR; Waukesha Beach, RR; Wis. Cen. RR.
- WISCONSIN INDUSTRIAL SCHOOL FOR (K) BOYS**; Chas. O. Merice, supt; Cotton Hosiery; 40 knitting machines; steam. *Goods for own use.*
- Waupaca**. D.5. W. C. RR.
- EVANS & BOWER**; (formerly J. W. (W) Evans); Cassimeres and Flannels; 1 set; 240 spindles; 4 looms; water; dye; sell direct.

## CANADA.

See map on page 284.

For explanation of abbreviations see page 66.

## BRITISH COLUMBIA.

**New Westminster.** B. I. & F. V.; C. P.; G. M. RR.

NEW WESTMINSTER WOOLEN MILLS; (W) Blankets; 1 set; 5 looms; 400 spindles; steam.

## MANITOBA.

**Brandon.** C. P.; N. P. RR

MANITOBA FELT AND YARN WORKS; (W) Ltd; \$30,000; J. Elliott, pres. and mgr.; Felts, Blankets, Yarns; 2 sets; 200 spindles; steam; dye; W. M. McLean, Montreal, s. agt.

**St. Boniface.** C. N.; C. P. RR.

WESTERN WOOLEN MILLS; John (W &amp; K) Ryan; Hosiery, Tweeds, Yarns, Flannels, Sheetings, Blankets, Mitts; 1 set; 4 looms; 190 spindles; 3 knitting machines; dye; steam; J. McLeod Holliday, Winnipeg, s. agt.

**Winnipeg.** C. N.; C. P.; N. P.; W. & St. M.; M. C. RR

DICK, RIDOUT &amp; Co.; Winnipeg Bag (J) Works; W. G. McMahon, mgr. and agt.; Jute and Cotton Bags; electric power. (See also Coburg, Ont.)

## NEW BRUNSWICK.

**Golden Grove.** Next station Rothesay or Kingston. Int'l RR.

WILLIS, Alex.; Golden Grove Woollen (W) Mills; Tweeds, Homespun, Blankets, Flannels, Yarns; 2 sets; 4 looms; 600 spindles; water; dye; sell direct.

**Marysville.** C. E. RR.

GIBSON COTTON MILLS; Canadian Color (C) ed Cotton Mills Co.; A. Gibson, pres.; C. H. Holt, sec. and treas.; H. Shaw, mgr.; Ginghams, Awings, Flannellets, Yarns; 13,000 ring and 14,000 mule spindles; 750 looms; steam; dye; D. Morrice, Sons &amp; Co., Montreal and Toronto, s. agts.

**Milltown.** C. P. RR.

ST. CROIX COTTON MILL; Canadian Col. (C) ton Mills Co.; Lewis Dexter, Jr., mgr.; D. Morrice, pres.; Chas. D. Owen, mang. dir.; A. Bruce, sec.; F. J. Muir, supt.; Ginghams, Dress Goods, Flannellets, Oxford, Yarns; 15,712 mule and 19,968 ring spindles; 145 looms; water; dye; D. Morrice, Sons &amp; Co., Montreal and Toronto, s. agts. (Buy 41 and 50 Egyptian yarn.)

**Moncton.** Int'l; M. & B. RR.

HUMPHREY, J. A. &amp; SON; Bannocks, (W) Tweeds, Blanketings, Yarns; 4 sets; 21 looms; 1400 spindles; steam; dye; sell direct. (Buy white and colored cotton 8 to 12.)

MONCTON COTTON MILLS; Dominion Cot. (C) ton Mills Co.; A. F. Gault, pres.; C. E. Hanna, sec.; L. G. Craig, treas.; B. Mole, gen. mgr.; Gray Sheetings; 7000 ring, 9000 mule spindles; 354 looms; steam; Stevenson &amp; Blackader, s. agts. (See also Montreal.)

**St. John.** C. P.; Int'l; S. L. RR.

CONSUMER'S CORDAGE Co; Ltd; \$3000,000; (F) Cordage and Twine; 60 spindles; steam. (Head office Montreal.)

CORNWALL AND YORK MILLS; \$500,000; C. G. W. Jones, pres.; J. B. Cudlip, mgr.; Flannellets, Cottonades, Denims; Hosiery and Warp Yarns; 15,000 ring, 12,600 mule spindles; 420 looms; steam and electricity; dye.

FAIRALL, W. H. &amp; Co.; Cashmere and (W) Worsted Hosiery and Stockinets; 8 knitting machines; electric power; sell direct. (Buy yarns.)

PARKS, W. J.; Hosiery and Stockinets; (W) 24 machines; steam; sell direct. (Buy 2s single woolen, 3/10 worsted; 4/24, 3/12 Botany worsted; 1/12, 1/6 cotton yarns.)

**Woodstock.** C. P. RR.

CARLETON WOOLEN Co.; Ltd; (W &amp; K) \$10,000; G. A. White, pres.; Andrew Meyles treas. and buyer; Yarns, Blankets, Tweed and Hosiery; 2 sets; 7 looms; 500 spindles; 3 knitters; steam; dye; sell direct.

## NEWFOUNDLAND.

**St. John's.** N. F. RR.

COLONIAL CORDAGE Co.; Ltd; \$160,000; (F) J. H. Monroe, mang. dir.; Cordage, Lines, Twines; steam; dye.

## NOVA SCOTIA.

**Antigonish.** Int'l RR.

ANTIGONISH WOOLEN MILL Co.; H. K. (W) Brine, mgr.; Custom Carding and Cloth Finishing; 4 sets; 240 spindles; steam; dye.

**Barrington.** H. & J. RR.

BARRINGTON WOOLEN MILLS; Robert D. (W) Doane; Tweeds, Dress Goods, Homespun, Yarns; 1 set; 6 looms 240 spindles; steam and water; dye; sell direct. (Buy cotton beam warps 8 to 15.)

**Dartmouth.** Int'l RR.

CONSUMER'S CORDAGE Co.; George (F) Stairs, mgr.; John Drury, supt.; Cordage, Twine; 200 spindles; steam.

**Eureka.** (Pictou County.)

EUREKA WOOLEN MFG. Co.; Ltd; \$400,000; M. H. Fitzpatrick, pres.; F. W. Harley, treas. and buyer; C. A. Clark, supt.; Tweeds, Flannels, Blankets; 3 sets; 9 looms; 774 spindles; water and steam; dye; sell direct. (Buy cotton warps.)

**Glendyer.**

MCDONALD BROS.; Glendyer Mills; (W) Homespun, Tweeds, Yarns, Blankets; 1 set; 6 looms; 300 spindles; steam and water; dye; sell direct. (Buy cotton warps.)

**Grand Anse.** (Richmond County.)

MCLEAN, HUGH; Tweeds; 1 set. (W)

**Halifax.** D. A.; Int'l RR.

DOMINION COTTON MILLS Co.; Nova Scotia (C) Mills; A. F. Gault, pres.; C. E. Hanna, sec.; L. G. Craig, treas.; B. Mole, gen. mgr.; Brown and Gray Cottons, Broad Sheetings, Yarns, Warp Yarns and Twine; 24,000 spindles; 500 looms; steam; dye; Stevenson &amp; Blackader, s. agts. (See also Montreal, Que.)

**Hopewell.** Int'l RR.

MCDONALD, JAS. &amp; SON; Yarns and (W) Carding; 1 set; 300 spindles; water; dye; sell direct.

**Margaree.** (Yerres County.)

ROSS, J. WESLEY; Tweeds, Blankets, (W &amp; K) Yarns; 1 set; 3 looms; 800 spindles; 2 knitters; water; dye; sell direct.

**Oxford.** Int'l RR.

OXFORD MFG. Co.; Ltd.; \$100,000; Wm. (W) Oxley, pres.; H. L. Hewson, treas., supt. and buyer; Homespun, Tweeds, Blankets, Yarns; 5 sets; 21 looms; 1200 spindles; 2 knitting machines; steam; dye; sell direct and through Nisbet &amp; Ault, Toronto and Montreal.

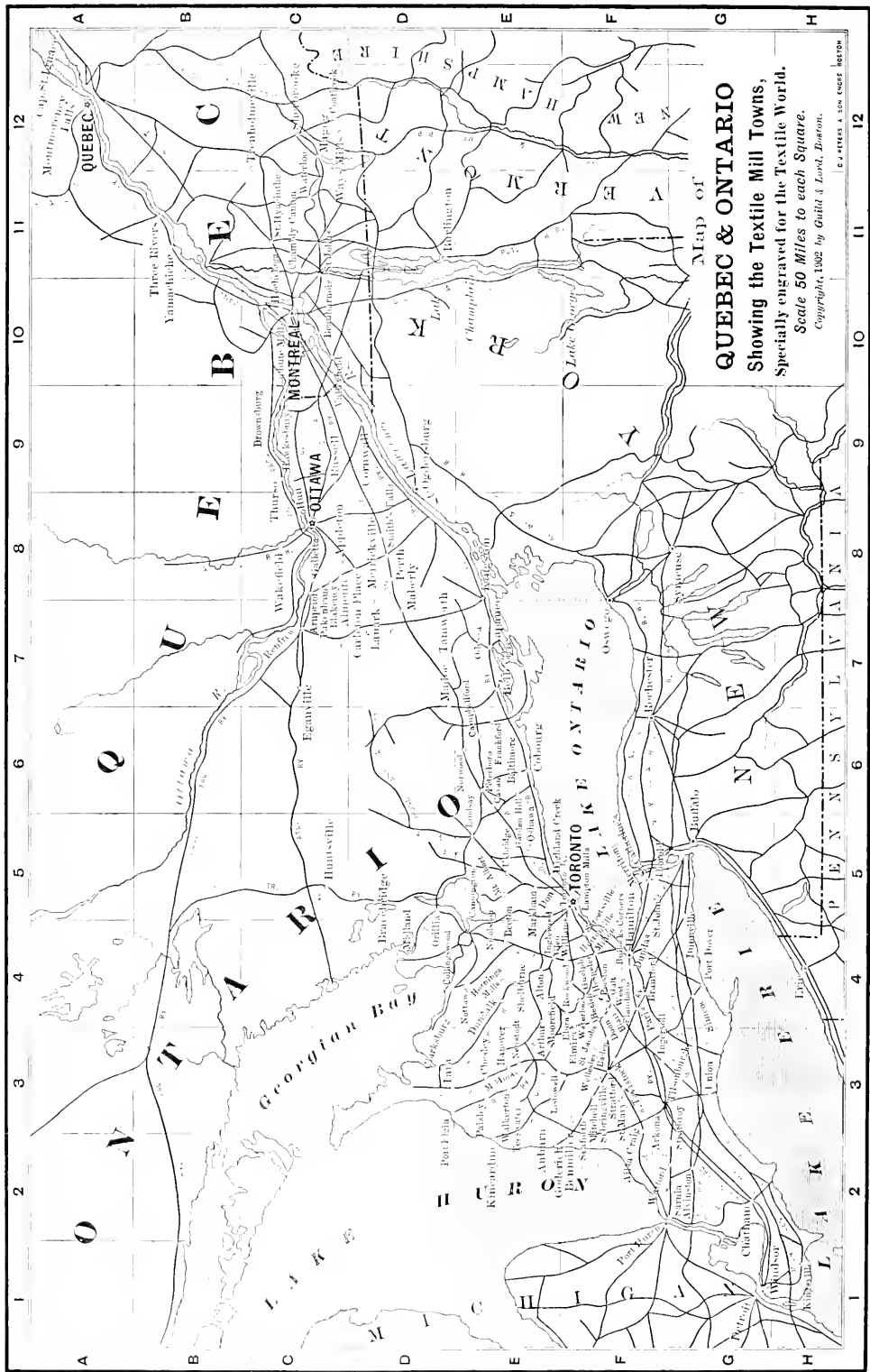

C. J. PETERS & SON ENGRAVERS BOSTON

**Rocklin.** (Picton Co.) Next station Hope well. Int'l RR.

**KERR BROS.** Tweeds, Yarns, Homes. (W) Spuns, Flannels; 1 set; 6 looms; steam and water; sell direct.

**Southampton.** C. R. & C. C. RR.

**VALLEY WOOLEN MILL Co.**; Tweeds, (W) Homespuns, Flannels, Yarns; 1 set; 4 looms; water; dye.

**St. Croix.** (Hantz County.)

**ST. CROIX WOOLEN MFG. Co.; Ltd.**; \$20. (W) 000; W. H. Mosher, pres.; G. B. Dawson, treas. and mgr.; Homespuns, Tweeds, Yarns; 1 set; 6 looms; 480 spindles; water; dye; sell direct.

**Stillman.** (Picton County.)

**HAMILTON, JAMES & SONS;** Tweeds, (W) Blankets, Homespuns, Flannels; 1 set; 5 looms; 240 spindles; steam and water; dye; sell direct.

**Truro.** M. of N. S.; Int'l RR.

**TRURO KNITTING MILLS Co.; Ltd.**; \$300. (K) 000; John Stanfield, pres.; Frank Stanfield, treas.; Shirts, Drawers, Ladies' Vests, Cardigan Jackets, 5 sets; 47 knitting and 25 sewing machines; 720 spindles; steam; dye; sell direct. (Buy 2-40 Egyptian, 1-20 cotton; 1-18, 1-36 worsted yarns.)

**Upper Stewiacke.** Next station Brookfield, Int'l RR.

**CREELMAN, JAMES & SONS;** Homespuns (W) and Yarns, Webbing; 1 set; 4 looms; water; sell direct.

**Waugh's River.** Next station Tatamagouche Int'l RR.

**MATHESON, JAMES & SON;** Balfour (W) Woolen Factory; Tweeds and Yarns, Homespuns; 1 set; 3 looms; water and steam; dye; sell direct.

**Windsor.** D. A.; M. of N. S. RR.

**DOMINION COTTON MILLS Co.; Windsor (C) Branch;** Geo. Wilson, supt.; Unbleached Cottons (Drills, Sheetings); 4600 ring and 6000 mule spindles; 270 looms; steam; sell direct.

**Yarmouth.** D. A.; H. & Y. RR.

**YARMOUTH DUCK & YARN Co.; Ltd.**; \$150. (C) 000; Robert Case, pres.; G. E. C. Burton, treas. and buyer; Sam. Killam, supt.; Cotton Duck and Twines; 10,000 spindles; 100 looms; steam; J. Spencer Turner Co., 71 Worth St., New York, s. agts.

## ONTARIO.

**Ailsa Craig.** F.3. G. T. RR.

**GUNN & Co.**; Scutched Flax and Tow. (F) 1

**Alliston.** (Not shown on map.) G. T. RR.

**UPTON, Geo.**; Flannels, Tweeds, (W & K) Yarns; Hosiery; 2 sets; 5 looms; 420 spindles; 5 knitting machines; water; dye; sell direct.

**Alma.** (Not shown on map.) G. T. RR.

**McGOWAN, JOHN D.**; Scutched Flax and (F) Tow; steam.

**Almonte.** C.S. C. P. RR.

**ALMONTE BLANKET Co.**; Wylie & Shaw; (W) Blankets, Coarse Tweeds; 3 sets; 4 looms; 720 spindles; water; dye; Geo. D. Ross & Co., Montreal, s. agts. (Buy cotton warps.)

**ALMONTE KNITTING Co.; Ltd.**; \$60,000; (K) Lord Strathcona, pres.; B. Rosamond, vice-pres.; J. M. Rosamond, mang. dir.; Men's Underwear and Sweaters; 4 sets; 35 knitting machines; water; dye; Holland & Haskell, Montreal, A. M. Angus & Co., Toronto, s. agts.

**ANCHOR KNITTING Co.; Ltd.**; \$50,000; (K) H. K. Pinhey, pres.; A. J. McAdam, vice-pres.; H. W. Lumby, supt. and buyer; Men's Woolen Shirts and Socks; 3 sets; 25 knitting machines; steam and water; dye; Jno. Gordon & Son, Montreal, s. agts.

**GOLDEN FLEECE WOOLEN MILLS;** Jas. (W) H. Wylie, prop.; Joseph Ainley, supt.; Tweeds; 2 sets; 3 looms; 560 spindles; water; John Gordon, Quebec, F. P. MacIntosh, Toronto, s. agts.

**ROSAMOND WOOLEN Co.**; \$300,000; Ben- (W) uelt Rosamond, pres. and mang. dir.; Lord Mount Stephen, vice-pres.; James Rosamond, sec. and treas.; Wm. Smith, supt.; Fine Tweeds, Cassimeres, Fancy Worsteds, Beavers, Moltons, Serges; 12 sets wool; 3 worsted cards, 58 broad, 28 narrow looms; 4 combs; 2500 worsted spindles; steam and water; dye; H. L. Henderson, Montreal, s. agt.

**SCANTLION, FRANK;** Shoddy and Waste; (W) 2 pickers; 4 garnet; water; sell direct.

**THORNTON, Wm.**; J. H. Bray, supt.; Fine (W) Wool Flannels; 1 set; 12 broad looms; water; dye; Wm. M. Angus & Co., Toronto, Holland & Haskell, Montreal, s. agts.

**WYLLIE, JAMES H.**; Elmstale Flannel (W) Mills; Joseph Ainley, supt.; Flannels; 3 sets; 4 looms; 1032 spindles; steam; dye; F. P. MacIntosh, Toronto, John Gordon & Son, Montreal, s. agts.

**Alton.** E. L. C. P. RR.

**ALGIE, Wm.**; Beaver Mills; Underwear (K) Shirts, Drawers, Yarns; 2 sets; 12 knitting frames; 8 sewing machines; 480 spindles; water; dye; sell direct and through F. Turner, Toronto. (Buy cotton hosiery yarns, 10, 12, 24, 26, 40.)

**DODD, JOHN M.**; Alton Knitting Mills; (K) Flat and Ribbed Underwear; 2 sets; 12 knitting and 7 sewing machines; 480 spindles; water; dye; W. M. Angus & Co., Toronto, Baker & Foster, Montreal, s. agts.

**WARD, G. W.**; Shirts and Drawers; (W & K) 2 sets; 480 spindles; 8 knitting and 12 sewing machines; water; Wm. M. Angus & Co., Toronto, s. agts.

**Altona.** (Not shown on map.) Next station Clarendon. C. P. RR.

**CLUTE, LINGOLX A.**; Blankets, Flannels, (K) Yarns, Hosiery and Cardigan Jackets; 1 set; 2 looms; 216 spindles; 4 knitting machines; water.

**Alvinston.** G.2. G. T. M. C. RR.

**WARNER, E. & SON;** Blankets; 1 set; 4 (W) looms; steam; dye; sell direct. (Buy beam warps, cotton, 6s for union blankets.)

**Appleton.** C.S. 2 1/2 m. from Carleton Place; C. P. RR.

**MISSISSIPPI WOOLEN MILLS;** J. Adam (W) Teskey, prop.; Arthur Devitt, supt.; Fancy Tweeds and Cassimeres; 2 sets; 12 looms; 800 spindles; water; dye; G. B. Fraser, Toronto, Holland & Haskell, Montreal, s. agts.

**Arkona.** F.2. (Next station Forest, G. T. RR.)

**DICKISON, ALEX.; A. Dickison,** supt. (W) and buyer; Stocking Yarn and Flannels; 1 set; 2 looms; 150 spindles; steam; dye; sell direct.

**Arnprior.** C.S. C. P.; O. & R. R. RR.

**DONTIGNEY & HUGHTON;** Tweeds, Blankets, (W) Kets, Kersseys; 2 sets; steam and water; Holland & Haskell, Montreal, Wm. M. Angus & Co., Toronto, s. agts.

**Arthur.** E.4. C. P. RR.

**McCORMACK, J. B.**; Arthur Woolen (W & K) Mills; Hosiery, Tweeds, Blankets, Flannels; 1 set; 3 looms; 200 spindles; 4 knitting machines; steam; dye; sell direct. (Buy worsted yarns.)

**PINDER, W.**; Full Dressed Flax, Flax Seed, Green and Rotted Tow; sell direct.

**Athens.** (Not shown on map.) B. W. & S. St. M. RR.

**GORDON, J. F.**; Yarns, Flannels and (W) Tweeds; 1 set; 1 loom; steam and water; dye; sell direct.

- Auburn.** E.3. Next station Blyth; G. T. RR. MORRISON, R.; Tweeds, Domestics; 1 (W) set; 2 looms; water. (Buy cotton warps No. 8.)
- Baltimore.** E.6. G. T. RR. EASTWOOD, E.; Flannels, Bed and Horse (W) Blankets; Dress Goods; Yarns; 2 sets; 3 looms; 200 spindles; water; dye. (Buy cotton yarn No. 9.)
- Barrie.** (Not shown on map.) G. T. RR. HOGG, GEO., & Co.; Tweeds; 2 sets; 6 (W) looms; 440 spindles; steam.
- Beavertown.** (Not shown on map.) G. T. RR. YOUNG, C. T.; Tweeds, Blankets, Flan. (W) nels, Yarns; 1 set; 3 looms; 200 spindles; steam; dye.
- Becton.** E.4. G. T. RR. WALLACE, JOHN, HOSIERY CO.; John (K) Wallace, prop.; Jas. Wallace, mgr.; Woolen Hosiery, Arctic Socks; 2 sets; 40 knitting machines; 300 spindles; steam; dye; sell direct and through J. Lockhart, Son, & Co., Toronto.
- Belleville.** E.7. G. T. RR. CITY WOOLEN MILLS; Wm. Lott, prop. (W) and buyer; Heavy Canadian Tweeds, Full cloths, Flannels and Yarns; 1 set; 5 looms; steam and water; dye; sell direct.
- Benn Miller.** F.2. Next station Holmesville. G. T. RR. GLEDDHILL, JESSIE; Tweeds, Blankets, (W) Flannels, Yarns; 1 set; 5 looms; 240 spindles; water; dye.
- Berlin.** F.4. G. T. RR. BERLIN FELT BOOT CO.; Geo. Rum. (W & K) pel. prop.; Felt Knit Goods and Yarn; 5 sets; 3 pickers; 720 spindles; 25 knitting and 50 sewing machines; steam; dye; sell direct.
- Blair.** F.4. G. T. RR. McNALLY, H.; Clemens & Co.; A. H. Mc (W) Nally, supt.; Blankets and Yarns; 1 set; 3 looms; water; dye; sell direct.
- Blakeney.** C.8. (RR. name Sudney); C. P. RR. McDougall, Peter; Tweeds; 2 sets; 7 (W) looms; water; dye.
- Bloomfield.** (Not shown on map.) C. O. RR. BLOOMFIELD WOOLEN MILLS; Sharp and W Bowerman; Tweeds, Blankets, Yarns; 1 set; 3 looms; 200 spindles; 3 knitting machines; steam and water; dye.
- Blyth.** (Not shown on map.) G. T. RR. ROBINSON & HENDERSON; A. W. Robin. (W) son, supt. and buyer; Balitax Tweeds, Yarns, Sheetings; 1 set; 4 looms; 220 spindles; steam; dye; sell direct.
- Bolton.** (Not shown on map.) C. P. RR. BOLTON WOOLEN MILLS; J. Walslaw, (W) prop.; Blankets; 3 sets; 13 looms; water and steam; dye. (Buy cotton yarn 12 to 16.)
- Bracebridge.** D.5. G. T. RR. BIRD, HENRY J.; Henry J. Bird, buyer; (W) Mackinaws and Heavy Tweeds, Flannels, Yarns; 1 set; 6 looms; water; dye; sell direct.
- Brantford.** F.4. G. T.; T. H. & B. RR. BRANTFORD LINEN MFG. CO.; William (C) Betty, mgr.; Linen, Cotton and Union Towels; 14 looms; gas engine; sell direct. DOMINION COTTON MILLS CO.; Brantford (C) Branch; A. F. Gault, pres.; C. E. Hanna, sec.; L. G. Craig, treas.; B. Mole, gen. mgr.; Gray Cottons; 12,164 spindles; 300 looms; steam and water; sell direct and through Stevenson & Blackader. (See also Montreal.) FARMER'S BINDER TWINE CO.; Ltd; \$150,000; Samuel Harold, pres.; William Irwin, sec. and treas.; Binder Twine; 90 spindles; steam; sell direct.
- HOMEDALE WINCEY MILLS; Dominion (W) Cotton Mills Co., Montreal, props; Union Flannels, Winceys; 15 sets; 106 looms; steam and water.**
- MALCOLM, M.; \$2500; M. Malcolm, treas.; (K) Hosiery; 12 knitting machines; sell direct. (Buy worsted yarns.)**
- ONTARIO FARMER'S CORDAGE CO.; Ltd; (F) \$65,000; S. G. Kitchen, pres.; C. E. Birkett, sec. and treas.; R. H. Riley, supt.; Binder Twine; sell direct.**
- SLINGSBY MFG. CO., Ltd; \$175,000; Frank (W) Dundas, G. T. RR. CLARK, A. & J.; Druggets, Blankets, (W) Tweeds, Rugs; 2 sets; 20 looms; 360 spindles; steam and water; dye; Millichamp, Coyle & Co., Toronto and Montreal, s.agts. (Buy cotton warp.)**
- Campbellford.** E.6. G. T. RR. TRENT VALLEY WOOLEN MFG. CO.; Ltd; (W) \$100,000; A. F. Gault, pres.; W. W. Cunningham, treas.; Geo. E. Burrows, supt. and buyer; Wooleens, Tweeds, Flannels, Coatings, Coat Linings and Dress Goods; 10 sets; 67 looms; water; dye; Geo. H. Bishop, Montreal, s. agts.
- Cannington.** E.5. G. T. RR. DOBSON & Co.; Blankets and Yarns; 3 (W) sets; 6 looms; 900 spindles; water and steam; dye; Millichamp, Coyle & Co., Montreal and Toronto, s. agts. (Buy 4 cotton.)
- Cargill.** (Not shown on map.) G. T. RR. CARGILL RIFE MFG. CO.; G. H. Rife, (W) supt. and buyer; Mixed Lot Tweeds, Blankets, Yarns; 1 set; 5 looms; steam; dye.
- Carleton Place.** D.8. (RR. name, Carleton Junction.) C. P. RR. CANADA WOOLEN MILLS; Ltd; Gillies (W) Mill; W. R. Brock, pres.; Geo. Davidson, sec. and treas.; John F. Morley, mgr; Fine and Fancy Worsteds and Tweeds; 4 sets; 23 looms; 2184 spindles; water; dye; Millichamp, Coyle Co., Montreal & Toronto, s. agts. (Head office Toronto, which see.) CANADA WOOLEN MILLS; Ltd.; Haw- (W) thorne Mill; W. R. Brock, pres.; Geo. Davidson, sec. and treas.; John F. Morley, mgr.; Medium Tweeds, Serges; 5 sets; 28 looms; 2500 spindles; steam; dye; Millichamp, Coyle & Co., Montreal and Toronto, s. agts. (Head office Toronto, which see.) McDONALD & BROWN; Knitting Yarns, (W) Flannels, Blankets, Tweeds; 1 set; 6 looms; water; dye; sell direct.
- Cavan.** E.6. RR. name Cavanville. C. P. RR. DOUGLAS, ROBERT; Flannels, Blankets, (W) Horse Covers, Yarns; 1 set; 3 looms; water; dye; sell direct.
- Chatham.** G.2. C. P.; G. P. & H.; G. T.; L. E. & D. R.; W. RR. CHATHAM BINDER TWINE CO.; \$125,000; (F) M. J. Wilson, pres.; T. C. Smith, sec. and treas.; Binder Twine and Rope, sell direct. TAYLOR, T. H., Co.; Ltd.; \$150,000; (W & K) T. K. Holmes, pres.; W. H. Taylor, sec. and treas.; Thos. Smith, supt.; Tweeds, Flannels, Blankets, Yarns, Homespun; 2 sets; 4 looms; 703 spindles; 8 knitting machines; steam; dye; sell direct.
- Chesley.** E.3. G. T. RR. GRANT, J. & Co.; Chesley Woolen Mills; (W) Tweeds, Etoffes, Flannels, Blankets; 1 set; 6 looms; 288 spindles; steam; dye; R. R. Davis, Toronto, s. agt.; and direct.

**Clarksburg.** D-4. (1 mile of Thornbury.)  
G. T. RR.

TELFER, Bros.; Ontario Blanket Co.; V. (W. E. Forster, supt.); Woolen and Union Blankets, Etoffes; 2 sets; 11 looms; 460 spindles; water; dye; sell direct.

**Coburg.** E-6. G. T. RR.

DEK, RIDOUT & Co.; Law, Whiteley, (W) supt. and buyer; Tweeds, Homespun, Worsteds; 8 sets; 32 broad looms; steam; dye; Alex. Alexander, Toronto, Geo. S. Plow, Montreal, Coburg Mfg. Cotton and Jute Works, Coburg, s. agts.

MITCHELL, Wm.; Cocoa Mattings and (J) Mats, Jute Mattings and Carpets; 31 looms; steam and water; dye.

**Collingwood.** D-4. G. T. RR.

WILLIAMS, HURLBERT Co.; Ltd.; \$25,000; (K) John Chamberlain, pres.; D. Williams, treas. and supt.; Wool, Worsted and Cotton Seamless Hosiery, Bicycle Hose, Mitts; 40 knitting and 3 sewing machines; 10 ribbers; steam; dye; sell direct. (Buy worsted and woolen yarns, 10 to 20.)

**Cornwall.** D-9. G. T.; O. & N. Y. RR.

CANADIAN COLORED COTTON MILLS Co. (Canada Mill); D. Morrice, pres.; A. Bruce, sec. and treas.; S. Greenwood, mgr.; J. B. McPherson, supt.; Shirts, Gingham, Awnings, Oxfords, Sheetings, Flannelettes, Cottonades, Dress Goods, Farcy Ducks; 33,640 spindles; 870 looms; steam and water; dye; D. Morrice, Sons & Co., Montreal and Toronto, s. agts.

CANADIAN COLORED COTTON MILLS Co. (Stormont Mill); S. Greenwood, mgr.; Arthur Bates, supt.; Shirts, Ticks, Checks, Gingham, Cottonades, Denims; 22,620 spindles; 632 looms; steam and water; dye; D. Morrice, Sons & Co., Montreal and Toronto, s. agts.

CORNWALL MFG. Co.; Ltd.; \$285,000; (W) Rob. Meighen, mang. dir.; James P. Watson, sec.; Coatings; Tweeds, Dress Goods, Homespun, Frieze; 9 sets; 58 looms; water and steam; dye; George S. Plow, Montreal, s. agt.

HODGE, Wm.; Wm. Hodge, supt.; Blankets, Flannels, Tweeds, Yarns; 1 set; 6 looms; water; dye; sell direct.

**Creemore.** (Not shown on map.) G. T. RR.

COUPLAND, GEORGE; Creemore Woolen (W) Mill; Yarns and Blankets; 1 set; 3 looms; 200 spindles; water; dye.

**Don.** E-5. C. P.; G. T. RR.

MILNE, C. S.; Pure Woolen Blankets, Union Blankets, Yarns; 1 set; 5 looms; water; dye; sell direct.

**Doon.** F-4. G. T. RR.

DOON MILLS; Jacob Cluth & Co.; Shod. (W) dy, Wool Batting, Flocks for Upholsterers, Mattresses; 3 cards; 2 pickers; water; sell direct and through R. Williams, Georgetown.

DOON WOOLSTOCK MILLS; J. T. Huber & (W) Co.; Shoddy, Woolstock, Mattress and Upholstery Stock; 2 pickers; 6 cards; steam and water; dye; sell direct.

PERINE & Co.; Twines and Cordage; sell (J) direct.

**Dundalk.** E-4. C. P. RR.

DUNDALK WOOLEN MILLS Co.; Ltd; \$20. (W) 000; James Russell, pres.; E. Monteistle, vice-pres.; John Sinclair, treas.; W. H. Peterson, mgr.; Tweeds, Blankets, Flannels, Yarns; 1 set; 7 looms; 240 spindles; steam; dye; sell direct.

**Dundas.** F-4. G. T.; H. & D.; T. H. & B. RR.

LENNARD, S. & SONS; S. J. Lennard, supt.; (K) and buyer; Cotton and Woolen Hosiery, Ladies' and Children's Underwear, Hats, Caps; steam; dye; The Richard S. Baker Co., Toronto, s. agts.

MEALEY, THOS. & Co.; Wool Stair Pads; (W) I gannett machine; 2 openers; water and steam.

**Dunville.** G-5. G. T. RR.

DOMINION HAMMOCK MFG. Co.; Ham. (C) mocs, Horse Nets, Counterpanes; 8 looms; gas; dye; Hutchinson, Sheerley & Berret, Toronto, s. agts. (Buy cotton yarns.)

ELLIOT, A. & Co.; Towels.

HOLT & KITCHEN; Dunville Carpet (W) Works; Ingrain Carpets; 6 looms; water; dye; sell direct and through Jos. Williams Toronto.

IMPERIAL KNITTING Co.; Ltd; \$40,000; (K) Hose and Half Hose; steam; dye.

SLINGSBY & WALTHO; Erie Woolen (W) Mills; Blankets, Flannels and Yarns; 1 set; 7 looms; 1 sewing machine; 240 spindles; water; dye; sell direct. (Buy yarns 10s to 2/14s.)

**Eganville.** C-7. C. A.; C. P. RR.

EGANVILLE WOOLEN MILLS; John (W) Childerhose & Co.; Tweeds, Flannels, Yarns, Military and Shanty Blankets; 1 set; 5 looms; 400 spindles; water; dye; sell direct.

**Elmira.** F-4. G. T. RR.

WINGER WOOLEN & FELT Co.; Ltd; (W) \$25,000; A. H. Erb, pres.; J. Hilborn, treas.; J. Peel, supt.; Henry Winger, vice-pres.; Horse Clothing, Socks and Felt Goods; 1 set; 3 looms; 240 spindles; 10 sewing machines; steam; dye; sell direct.

**Elora.** F-4. C. P.; G. T. RR.

BAIN & Co.; Elora Woolen Mill; Blankets, Flannels, Tweeds; 2 sets; 8 looms; 500 spindles; steam and water; dye; sell direct.

**Frankford.** E-6. C. O. RR.

SILLS & Bros.; W. P. Sharp, supt.; (W) Tweeds, Flannels, Yarns; 1 set; 2 looms; 160 spindles; water; dye; sell direct. (Buy cotton warps.)

**Galetta.** C-8. C. A. RR.

GALETTA WOOLEN MILLS; Galetta (W) Whyte, prop.; E. Charbonneau, supt.; Etoffes, Friezes, Halifax Tweeds and Dragonals; Blankets, Yarns; 1 set; 5 looms; water; dye; Wm. M. Angus & Co., Toronto, s. agts.

**Galt.** F-4. C. P.; G. P. H.; G. T. RR.

COOPER, MRS. M.; Shoddy and Wool (W) Batting; 2 cards; 1 picker; steam.

GALT CARPET Co.; Ltd; \$40,000; H. H. (C) Burrows, pres. and supt.; Carpets, Art Squares, Rug Fringes, Carriage Buster; 7 power, 5 hand looms; steam; dye; sell direct.

GALT KNITTING Co.; Ltd.; \$40,000; A. (K) Harnock, pres.; C. R. H. Harnock, treas. and buyer; A. F. Robb, supt.; Underwear, Eiderdowns, Shoe Linings; 4 sets; 1200 spindles; 20 knitting machines; steam; dye; sell direct. (Buy cotton yarns 18s to 34s.)

MCCARTNEY, Wm. R.; Fine Full Fash. (K) ionic Wool and Worsted Underwear for Men, Ladies and Children; 6 knitting machines; sell direct. (Buy woolen and worsted yarns.)

MCKAY, M. S. & Co.; Woolen Yarns; 1 (W) set; 288 spindles.

NEWLANDS & Co.; Joseph Stauffer, mgr.; (K) Glove and Shoe Lining; Jersey Cloth, Imitation Buffalo Robes, Dogskin; 12 cylinders; 6 rib knitting and 8 sewing machines; steam; dye; sell direct. (Buy cotton yarns, 8s to 32s, woolen yarns, 8s to 24s.)

TURNBULL, C. Co; Ltd; \$50,000; Full (K) Fashioned and Ribbed Men's, Ladies' and Children's Knit Underwear; 1 sets; 40

- knitting machines; steam and water; dye; sell direct. (Buy yarns: cotton, 8s to 18s, worsted 1/20s to 2/60s.)
- Garden Hill.** E.6. G. T. RR.
- DYER, JAMES H. & Co.;** Tweeds, Flannels, Etoffes and Yarns; 2 sets; 10 looms; 600 spindles; water; dye; sell direct.
- Glen Williams.** F.4. G. T. RR.
- BEAUMONT, JOSEPH;** Woolen Yarns, (W & K) Batting and Hosiery; 2 pickers; 2 sets; 480 spindles; 50 knitting machines; 4 sewing machines; water; dye; sell direct and through Geo. D. Ross & Co., Montreal and Toronto. (Buy worsted Yarns.)
- SYKES & AINLEY MFG. CO.;** Ltd; (W) Glen Woolen Mills; \$100,000; John Sykes, pres. and supt.; Norman Ainley, vice-pres.; Harry Holdroyd, sec. and treas.; Tweeds, Blankets, Fancy Rugs, Carpet Yarns, Kerseys; 4 sets; 30 looms; 1500 spindles; 4 sewing machines; steam and water; dye; Geo. D. Ross & Co., Montreal and Toronto, s. agts. (Buy cotton yarns, 2/20, 2/24.)
- Goderich.** E-2. G. T. RR.
- GODERICH KNITTING CO.;** Ltd; \$9000; (K) George Acheson, pres.; C. A. Nairn, treas.; R. C. Hays, sec.; J. E. Lewitt, supt.; Full Regular Ribbed and Plain Hosiery and Mitts; 75 knitting machines; steam; The Richard Baker Co., Toronto, s. agts. (Buy yarns.)
- MCCLELLAND, M. M.;** McCann Woolen (W) Mill; Blankets, Yarn, Flannels, Tweeds; 1 set; 3 looms; 200 spindles; water; dye; sell direct.
- Guelph** F.4. C. P.; G. T. RR.
- CARTLIDGE, JOSEPH & SON;** Knitted (K) Gloves, Mitts, Hosiery and Yarns; 2 sets; 508 spindles; 52 knitting machines; steam; Geo. D. Ross & Co., Montreal and Toronto, s. agts.
- GUELPH CARPET MILLS CO.;** \$40,000; (W) C. K. Kloefer, pres; G. McPherson, vice-pres.; R. Dodds, treas.; B. Westwood, supt.; Brussels and Ingrain Carpets; 35 looms; steam; dye; sell direct. (Buy yarns.)
- ROYAL CARPET CO.;** H. H. Burrows, (W) prop.; Ingrain Carpets and Art Squares; 24 looms; dye; sell direct. (Buy cotton warps 2-14 and yarns.)
- ROYAL KNITTING CO.;** Samuel Carter, (K) prop.; Mitts, Gloves, Hosiery, Caps and Toques; 75 machines; steam; dye; G. A. Jones & Co., Toronto, s. agts. (Buy cotton, woolen and worsted yarns.)
- WOOTEN, THOS.;** Hosiery, Gloves, Mitts; (K) 15 hand machines; sell direct.
- Hamilton.** F.5. G. T.; H. G. & B.; H. R.; H. & D.; T. H. & B. RR.
- CANADIAN COLORED COTTON MILLS CO.;** (C) Ltd; Ontario Mill; (see also Merriton); D. Morrice, pres.; A. Bruce, treas.; Chas. O. Dexter, mgr.; Geo. O. Dexter, supt.; Shirtings, Tickings and Denims; 13,248 ring spindles; 400 looms; steam; dye; D. Morrice Sons & Co., Montreal and Toronto s. agts.
- CHIPMAN-HOLTON KNITTING CO.;** \$150,000; (K) 000; F. L. Chipman, pres.; W. H. Holton, treas.; Hosiery; electric power; dye.
- EAGLE KNITTING CO.;** J. R. Moodie, (K) pres.; James Moodie, buyer; Children's and Ladies' Ribbed Underwear, Men's and Ladies' Balbriggan and Fleece Lined Goods; 128 knitting machines; electric power. (Buy cotton yarns 6 to 43, Lisle and Egyptians.)
- HAMILTON COTTON CO.;** James M. Young, (C) prop.; Wm. Armstrong, supt. and buyer; Cottonades, Denims, Yarns, Webbing, Cordage, Chenille Goods; 6000 spindles; 100 looms; steam; dye; D. Morrice Sons Co., Montreal, W. B. Stuart, Toronto, s. agts.
- IMPERIAL COTTON CO.;** Ltd; \$750,000; J. M. (C) Young, pres.; C. J. Grantham, treas. and agt.; David Bell, supt.; Cotton Ducks; 10,000 ring spindles; 175 looms; electric power; J. Spencer Turner Co., s. agts.
- MAIN, ALEX & SON;** Twines and Cord. (C & J) age; steam. (Buy coarse cotton and jute yarns.)
- PERRY, G. B., KNITTING CO.;** Ladies' (K) and Children's Ribbed Cotton and Wool Underwear; 7 knitting, 10 sewing machines; sell direct. (Buy cotton and woolen yarns 8 to 43.)
- Hanover.** E.3. G. T. RR.
- HANOVER WOOLEN MILLS CO.;** Ltd; (W) \$20,000; Wm. Irvine, pres.; H. Ahrens, treas.; Jacob Messinger, supt. and buyer; Hosiery, Blankets, Yarns; 1 set; 4 looms; water; dye; G. B. Fraser, Toronto, Donald Fraser, Montreal, s. agts.
- Hawkesbury.** C-9. C. A.; G. M. RR.
- MORRISON, J. B.;** Yarns, Kerseys, (W) Etoffes, Blankets, Tweeds, Flannels; 1 set; 3 looms; steam and water; dye.
- Hespeler.** F.3. G. N.; G. T. RR.
- CANADA WOOLEN MILLS;** The Brodie (W) Mills; W. R. Brock, pres.; Geo. Davidson, sec. and treas.; John F. Morley, mgr.; Flannels, Serges, Tweeds, Dress Goods and Cloakings; 20 sets; 170 looms; 9600 spindles; steam and water; dye; Mill-champ, Coyle & Co., Toronto and Montreal s. agts. (Head office Toronto, which see.)
- FORBES, R. CO.;** Ltd; \$800,000; (W & K) Geo. D. Forbes, pres. and buyer; W. H. Weaver, supt.; Fancy Knit Goods, Worsted Serges, Fancy Worsteds, Worsted and Woolen Yarns; 7 worsted cards; 6 sets; 57 looms; 6 combs; 3500 spindles; 25 knitting, 20 sewing machines; steam and water; dye; sell direct. (Buy fine cotton and worsted yarns.)
- Highland Creek.** E-5. G. T. RR.
- KIRKHAM, A. L.;** A. L. Kirkham, supt.; (W) A. T. Elliot, buyer; Cotton and Wool Bats and Flock for Upholstery Purposes; 1 set; 1 rag picker; 1 bat machine; water; sell direct.
- Hornings Mills.** E.4. Grey County
- BROWN, JOHN;** Boy's and Men's (W & K) Sweaters, Woolen Shirts, Hosiery; 1 set; 3 looms; 240 spindles; 8 knitting machines; water; dye; John Forsyth, s. agt.
- Huntsville.** C-5. G. T. RR.
- HALL, JAMES;** Blankets, Yarns, Flannel (W) and Full Cloth; 1 set; 4 looms; 240 spindles; steam; dye; sell direct.
- Huttonville.** F.4. Peel County.
- MCMURCHY, J.;** Huttonville Woolen (K) Mills; Cashmere, Wool and Worsted Hosiery; 2 sets; 900 spindles; 35 knitting and 3 sewing machines; water; dye; Mill-champ, Coyle & Co., Toronto and Montreal, s. agts. (Buy yarns.)
- Ingersoll.** F.3. C. P.; G. T. RR.
- WATERHOUSE & BRADBURY;** Tweeds, (W) Sheerings, Yarns; 1 set; 5 looms; 240 spindles; steam and water; dye; W. M. Angus & Co., Toronto, A. A. McDougall & Co., Montreal, s. agts.
- Inglewood.** E.4. RR. name Inglewood Junction. G. T.; C. P. RR.
- GRAHAM, D., SONS & CO.;** Men's and (K) Boys' Underwear, also Fleece; 2 sets; 17 knitting machines; steam and water; sell direct. (Buy yarns, 20s mixes, 22s white, 6s backing.)
- Keenansville.** (Not shown on map.)
- BROWN, W. & C.;** Blankets, Flannels, (W & K) nels, Yarns, Carpets, Hosiery; 1 set; 9 looms; 300 spindles; 2 knitting machines; water; dye.
- Kincardine.** E-2. G. T. RR.



- MCKENZIE, E.;** E. McKenzie, buyer; **W** Blankets, Sheetings, Yarns; 1 set; 2 narrow and 1 broad looms; steam; dye; sell direct.
- Kingston.** E.S. B. of Qu. & R. N. Co.; G. T.; K. & P. RR.
- DOMINION COTTON MILLS CO.** (Kingston) **C** Branch; A. F. Gault, pres.; C. E. Hanna, treas.; B. Mole, gen'l mgr.; Gray Sheetings; 14,500 spindles; 528 looms; steam; Stevenson & Blackader, s. agts. See also Montreal.)
- KINGSTON CORDAGE WORKS;** J. F. Fergu **FI** son, prop.; Rope, Lath Ties; electric power; sell direct.
- KINGSTON HOSIERY CO.;** Ltd.; \$200,000; **K** Geo. Richardson, pres.; John Hewton, treas., act.; supt. and buyer; Knitted Underwear and Hosiery; 6 sets; steam; dye; sell direct. (Buy yarns, worsteds 1-18, 30, cotton 24; Japer, 308 white, 40s Egyptian, mercerized 2-40-2-50.)
- Kingville.** H-I. L. E. & D. R. RR.
- BROWN & WIGLE CO.;** Ltd.; \$200,000; S. A. **W** King, pres.; E. A. Brown, sec. treas. and buyer; J. E. Brown, mgr.; Blankets, Cloakings, Shirting, Horse Blankets, Yarns; 2 sets; 12 looms; steam; dye; sell direct and through Nisbit & Auld, Toronto. (Buy cotton yarns Nos. 4, 10, 12.)
- Lambton Mills.** F-5. C. P.; G. T. RR.
- CANADA WOOLEN MILLS;** Lambton **W** Mills; W. R. Brock, pres.; Geo. Davidson, sec. and treas.; John F. Morley, mgr.; Flannels, Tweeds; 5 sets; 32 looms; steam and water; dye. (Head office, Toronto, which see.) (Mill burned in 1901; not rebuilt.)
- Lanaok.** D-7. Next station Perth. C. P. RR.
- CALDWELL, BOYD & CO.;** Clyde Woolen **W** Mills; Fine Fancy Tweeds, Cassimeres, Meltons; 4 sets; 24 looms; 1240 spindles; steam; dye; sell direct. (Buy worsted yarns.)
- CALDWELL, W. C.;** George Bond, supt.; **W** W. C. Caldwell, buyer; Yarns, Blankets, Kerseys, Flannels, Tweeds; 1 card; 4 looms; water; dye; sell direct.
- Lindsay.** E-5. G. T. RR.
- LINDSEY WOOLEN MILLS;** Horn **W & K** Bros.; Flannels, Blankets, Tweeds, Horse Covers, Yarns, Hosiery and Underwear; 2 sets; 5 looms; 4 knitting and 1 sewing machines; 400 spindles; steam; dye; sell direct.
- Listowel.** E-3. G. T. RR.
- LISTOWEL WOOLEN MILLS;** B. F. **W & K** Brook, prop.; Tweeds, Flannels, Yarns and Blankets; 1 set; 2 broad and 2 narrow looms; 2 hose machines; steam; dye; sell direct. (Buy worsted yarns 2, 3, 4 ply.)
- Lyn.** (Not shown on map.) B. W. & S. Ste. M.; G. T. RR.
- CLIMMING, JAMES;** Coarse Tweeds; 1 set; **W** 6 looms; dye.
- Maberly.** D-7. C. P. RR.
- URE, JAMES A.;** Woolen Blankets, **W** Tweeds and Flannel Cotton Warps, Woolen Filling; 1 set; 1 hand and 1 power loom; 141 spindles; water.
- Madoc.** D-6. G. T. RR.
- DANFORD, S. J.;** Tweeds, Yarns, Domes; **W** ties; 1 set; 3 looms; 200 spindles; steam and water; dye. (Buy cotton warps 8 to 10.)
- Markdale.** (Not shown on map.) C. P. RR.
- RITCHIE, F. J.;** Blankets, Flannels, Rag Carpets; 1 set; 4 looms; 1 knitting machine.
- Markham.** E-5. G. T. RR.
- MAPLE LEAF WOOLEN MILLS CO.;** Flannels, Tweeds; 5 sets; 24 looms; steam; dye.
- Marmora.** (Not shown on map.) C. O. RR.
- PEARCE, E. T. P. Co.;** Ltd.; Blankets, **W & K** Tweeds, Hosiery; 1 set; 5 looms; 240 spindles; 2 knitting machines; water; dye.
- Merrickville.** D-8. C. P. RR.
- WATCHORN & CO.;** Tweeds, Flannels, **W** Yarns; 2 sets; 10 looms; 720 spindles; water; dye; sell direct.
- Merritton.** F-5. G. T.; N. St. C. & T. RR.
- CANADIAN COLORED COTTON MILLS CO.;** **C** Ltd.; Merritton Mill; D. Morrice, pres.; A. Bruce, treas.; Chas. O. Dexter, mgr.; Robert J. Woodside, supt.; Cotton Blankets, Domets, Carpet Warps and Demicord; 3556 mule and 8144 ring spindles; 92 broad and 136 narrow looms; water; dye; D. Morrice, Sons & Co., Montreal and Toronto, s. agts.
- HOWARTH, RICHARD;** Cotton Tow. **W & K** els.; Carpet Yarns, Cotton and Wool Batting, Ingrain Carpets; 1 set; 1 picker; 4 looms; 2 knitting machines; water; dye. (Buy cotton yarns 2-14 and 2-20.)
- MERRITTON KNITTING MILL;** M. A. **K** bright, prop.; Cotton and Wool Hosiery; 1 set; 240 spindles; 4 knitting and 10 sewing machines; electric power; dye.
- Midland.** D-4. G. T. RR.
- O'HARA & SONS;** Tweeds, Blankets, **W** Flannels, Yarns; 1 set; 5 looms; 200 spindles; steam; dye; sell direct.
- Mildmay.** E-3. G. T. RR.
- MILDMAY WOOLEN MILL;** McKelvie & **W** Hemphill; Druggets, Tweeds; 1 set; 8 looms; 240 spindles; water; dye.
- VOIGT & ROSENOW;** Scutched Flax and **FI** Tow.
- Milton.** F-4. C. P.; G. T. RR.
- CANADIAN CARPET CO.;** S. Syer, supt.; **W** Wool and Union Art Squares; 40 looms; steam; dye; sell direct.
- Mitchell.** F-3. G. T. RR.
- BURRITT, A. & Co.;** Hosiery and Under; **K** wear; 85 knitting machines; steam; dye; sell direct.
- DEEYON, SONS & WATERHOUSE;** Blank **W** ets, Tweeds, Cheviots, Etoffes, Yarns; 1 set; 10 looms; 308 spindles; steam; dye; A. A. McDougall & Co., Montreal, s. agts. (Buy worsted yarns.)
- FORRESTER, ANDREW;** Scutched Flax **FI** and Tow.
- Moorefield.** E-3. G. T. RR.
- MOOREFIELD FLAX MILL CO.;** \$5000; A. **FI** Macdonald, supt. and sec.; Tow and Dressed Flax; steam; sell direct.
- Mount Albert.** E-5. G. T. RR.
- HAIGH, GEO. & Son;** Mount Albert **W** Woolen Mills; Flannels, Blankets, Etoffes, Yarns; 2 set; 6 looms; 400 spindles; 1 knitting and 1 ribbing machine; steam and water; dye; sell direct.
- Mount Forest.** (Not shown on map.) C. P.; G. T. RR.
- MOUNT FOREST WOOLEN MILLS CO.;** **W & K** James, staple, pres.; Geo. Watson, vice-pres.; A. E. Tanner, sec.; Chas. Melmes, treas. and supt.; Blankets, Flannels, Tweeds, Yarns; 1 set; 6 looms; 1 sewing machine; 240 spindles; steam and water; dye. *Idle. For sale.*
- Napanee.** E-7. B. of Qu. R. & N. Co.; G. T. RR.
- PERRY, JAMES;** Napanee Woolen **W & K** Mill; Tweeds and Yarns; 2 sets; 6 looms; 2 knitting machines; 410 spindles; water; dye; sell direct.
- New Hamburg.** (Not shown on map.) G. T. RR.
- NEW HAMBURG FELT MFG. CO.;** E. & C. **W** F. Merner; Felt Goods, Horse Blankets; 4 cards; steam; sell direct.

**Ottawa.** E-4. G. T. RR.

CHASE, J. R. & CO.; Blankets, Sheeting (W) and Yarns; 1 set; 5 looms; steam and water; dye; sell direct. (Buy cotton warp.)

**Odessa.** E-7. Next station Newburgh. B. of Qu. R. & N. Co. RR.

ODESSA WOOLEN MILLS CO.; E. M. Booth, (W) prop.; Hosiery Yarns on Cones, Blankets, Sheatings, Tweeds; 2 sets; 4 looms; 580 spindles; water; dye; Millchamp, Coyle & Co., Toronto, s. agts.

**Orillia.** D-5. G. T. RR.

HEHN, JOHN; Tweeds, Etoffes; 1 set; 4 (W) looms; steam.

MCKAY & CO.; Tweeds, Blankets, Full (W) Cloths and Yarns; 1 set; 4 looms; 200 spindles; steam; dye. (Buy white cotton No. 8.)

**Oshawa.** E-5. O. R. R.

SCHOFFELD WOOLEN CO.; Ltd; Jonathan (K) Schoffeld, pres.; J. A. Schoffeld, treas.; Top Shirts and Flat, Fleeeced and Ribbed Underwear, Sweaters; 2 sets; 23 knitting, 52 sewing machines; 912 spindles; steam; dye; Millchamp, Coyle & Co., Toronto, s. agts. (Buy cotton yarns 10 to 40 and mercerized yarns.)

**Ottawa.** C-8. C. A.; C. P.; O. & N. Y. RR.

MANCHESTER, DAVID; (Ottawa Woollen (W) Mills); Yarns, Kerseys and Flannels; 1 set; 1 loom; 480 spindles; electric power; dye; sell direct.

**Otterville.** (Not shown on map.) G. T. RR.

LOSSING, SOLOMON B.; Tweeds, Flannels and Yarns; 1 set; 2 looms; 120 spindles; water; dye.

**Owen Sound.** (Not shown on map.) C. P.; G. T. RR.

HARRISON, MRS. S.; John Harrison, mgr.; (W) Tweeds, Flannels and Yarns; 1 card; 6 looms; 228 spindles; steam and water; dye; sell direct.

**Paisley.** E-3. G. T. RR.

ANCHOR CARPET MILLS; \$30,000; R. D. (W) McDonald, agt.; G. A. Buttows, supt. and buyer; High Grade Wool and Union Carpets, Art Squares, Fringes, Wool Rugs; 4 looms; steam; dye. (Buy wools, worsted and cotton; wool yarns, jute carpet yarns.)

FISHER'S WOOLEN MILLS; A. M. Fisher, (W) buyer; Tweeds, Flannels, Blankets, and Yarns; 1 set; 5 looms; steam and water; dye; G. B. Fraser, Toronto, D. Fraser, Montreal, s. agts.

**Pakenham.** C-8. C. P. RR.

FRANCIS & BRAZEAN; Tweeds and (W) Yarns; 1 set; 5 looms; dye; A. A. McDougall & Co., Montreal, s. agts.

**Paris.** E-4. G. T. RR.

CANADIAN HAMMOCK MFG. CO.; \$3,200; (C) David Brown, pres.; John Allen, sec. and treas.; Cotton Hammocks and Horse Nets; H. D. Simmons, Montreal, s. agt. (Buy yarn 3/8, 4/8, 5/8, 6/8 and 33 L 4.)

PARIS WINCEY MILLS CO. THE; O. H. (W) Baird, treas.; H. Strove, mgr.; John H. Martin, supt.; Union and All Wool Flannels, Tweeds, Serges, Costume Cloths, Linings, Dress Goods; 5 sets; 50 looms; steam and water; dye; F. P. Mackintosh, Toronto, John S. Shearer & Co., Montreal, s. agts.

PENMAN MFG. CO.; Ltd; \$1,000,000; John (K) Penman, pres.; O. R. Whitby, treas.; J. B. Henderson, gen. mgr.; Seamless Hosiery and Full Fashioned Shirts, Drawers, Blankets, Plush; 14 sets; 3400 spindles; 40 cylinders; 125 knitting, 100 sewing machines; steam and water; dye; D. Morrice, Sons & Co., Montreal, s. agts; (see also Port Dover, Thorold, Ont., and Coni-cook, P. Q.)

WATSON MFG CO.; \$30,000; W. P. Long, (K) pres.; J. B. Henderson, gen. mgr.; O. R. Whitby, treas.; E. P. Watson, supt.; Women's and Children's Cotton, Woolen, Worsted, Silk and Lisle Ribbed and Fleeeced Underwear and Combinations; 65 knitting, 75 sewing machines; water and steam; dye; Donald Frazer, Montreal, T. P. Machintosh, Toronto, s. agts. and direct. (Buy yarns 6 to 60.)

**Pembroke.** (Not shown on map.) C. A.; C. P. RR.

PEMBROKE WOOLEN MILLS; James Mc. (W) Lean; B. Pointer, supt.; Yarns, Tweeds, Flannels, Blankets, Etoffes, Kerseys, Socks; 1 set; 5 looms; 400 spindles; 1 knitting and 1 ribbing machine; water; dye; sell direct.

**Perth.** D-8. C. P. RR.

PERTH WOOLEN CO.; Ltd; \$25,000; F. A. (W) Code, pres.; John Code, treas.; D. Hudson, supt. and buyer; Boot and Shoe Felt, Hat Felt, Clothiers' Padding, Shoe Lining, Robe Trimming, Harness Refrigerator Felt, Fancy Tweeds, Cheviots, Cassimeres, Erieze; 5 sets; 9 looms; steam; dye; Geo. S. Plow, A. Alexander, Montreal, s. agts.

**Peterboro.** E-6. C. P.; G. T. RR.

AUBURN WOOLEN CO.; Ltd; \$200,000; (W) James Kendry, pres. and supt.; Tweeds and Cassimeres; 10 sets; 55 looms; 3200 spindles; steam and water; D. Morrice, Sons & Co., Montreal, s. agts.

CANADIAN CORDAGE & MFG. CO.; \$400,000; F. I. Adam Hall, pres.; R. M. Glover, sec.; W. T. Clark, gen. mgr.; Binder Twine.

ELLIOTT, T. C. & CO.; Hosiery, Under. (K) wear, Mitts, Toques; 22 knitting machines; electric power.

PETERBOROUGH UNDERWEAR CO.; R. H. (K) Kells, supt. and buyer; Fleeces, Flats; 21 knitting machines; sell direct.

**Port Dover.** G-4. G. T. RR.

PENMAN MFG. CO.; James Ellis, (W & K) mgr.; Underwear and Over-shirts; 4 sets; 152 spindles; 23 knitting and 35 sewing machines; 11 circular head and 8 flat cuff frames; water; dye; D. Morrice, Sons & Co., Montreal and Toronto, s. agts. (Buy cotton yarns 20 to 50.) (Head office at Paris, which see.)

**Port Elgin.** D-3. G. T. RR.

BARBER, M. G. & SON; Heavy Tweeds, (W) Blankets, Flannels, Yarns; 1 set; 3 looms; steam; dye; sell direct.

**Preston.** E-4. G. P. H.; G. T. RR.

PATTINSON GEO. & CO.; Overcoatings, (W) Costume Cloths, Cassimeres; 7 sets; 50 looms; water and steam; dye; sell direct.

VICKERMAN, D. & SON; Speedville (W) Woollen Mills; Blankets, Flannels, Knitting and Stocking Yarn; 2 sets; 8 looms; 480 spindles; water; dye; sell direct. (Buy cotton warps.)

**Renfrew.** C-7. C. A.; C. P.; K. & P. RR.

LOGAN BROS.; Thos. Logan, supt. and buyer; Tweeds, Blankets, Kerseys; 1 set; 8 looms; water and steam; dye; W. M. Angus & Co., Toronto, A. A. McDougall & Co., Montreal, s. agts.

**Rockwood.** E-4. G. T. RR.

HARRIS & CO.; Ltd.; \$45,000; W. Harris, (W) pres., supt. and buyer; C. Harris, treas.; Erieze, Overcoatings, Ladies' Suitings; 2 sets; 16 looms; steam and water; dye; Dignum and Monypenny, Toronto, s. agts.

WOOD, J. T.; Excelsior Knitting Works; (K) Seamless Wool and Worsted Hosiery, Underwear, Mitt and Glove Linings; 1 set; 240 spindles; 50 knitting, 10 ribbing and 3 sewing machines; water; dye; sell direct.

**Russell.** C-9. O. & N. Y. RR.

- CORSCADDEN, THOS., & SON;** Albert Cors. (W) cadden, buyer; Tweeds, Blankets, Flannel and Kersey; 2 sets; 8 looms; steam and water; dye; sell direct.
- Sarnia.** G-2. G. T.; L. E. & D. R. RR.
- SARNIA WOOLEN MILLS;** Newton Bros. (W) Tweeds, Etoffes, Flannels, Blankets, Yarns; 2 sets; 9 looms; 840 spindles; steam; dye; sell direct. (Buy warps 4 to 12.)
- Seaforth.** F-3. G. T. RR.
- VAN EGMOND, W. D.;** W. D. Van Eg. (W) mond, supt. and buyer; Tweeds, Dress Goods, Homespuns; 2 sets; 12 looms; steam; dye; sell direct.
- Sebringville.** F-3. G. T. RR.
- SEBRINGVILLE FLAX CO.;** Ltd; \$12,500; (F) Jacob Kichma, pres.; J. J. Paul, M. D., treas.; Robert Smith, supt.; Coarse, Fine and Green Tow, Flax Fibre; steam; sell direct.
- Shelburne.** E-4. C. P. RR.
- BELLERBY, M. C. & Co.;** Dufferin Hos-tery Co.; Seamless Hosiery and Half Hosiery; 4 knitting machines; dye; sell direct. (Buy worsted yarns.)
- Simcoe.** G-4. G. T.; W. RR.
- BROOK WOOLEN CO.;** Ltd; \$25,000; G. H. (W) Luscombe, pres.; Joseph Brook, treas., supt. and buyer; Horse Blankets, Frieze, Tweeds, Rugs, Dress Goods, Pants; 3 sets; 15 looms; steam; sell direct.
- CHALLAND, JOHN & Co.;** Shoddy; 2 pick-ers; water; sell direct.
- NICHOL, JAMES;** Stockings and Socks; (K) 4 knitting machines; sell direct.
- SIMCOE WOOLSTOCK CO.;** Wm. Jagins. (W) pres.; C. C. Dove, mgr.; Shoddy; 2 sets; 2 pickers; dye; sell direct. *Burnt out Apr., 1902.*
- Smith Falls.** D-S. C. P. RR. RR. name Smith Fall Junction.
- ALLPORT D.;** Tweeds and Flannels, Et-offes, Blankets and Knitting Yarns; 1 set; 4 looms; 240 spindles; steam and water.
- St. Catharine's.** F-5. G. T.; M. St. C. & T. RR.
- CANADA HAIR CLOTH CO.;** James A. Mc- Sloy, pres.; H. E. Mesloy, sec. and treas.; Hair Cloth Crinoline and Seating; 75 looms; water; sell direct. (Buy cotton 1-16 and 3-16.)
- CHANNEL, W. E.;** Hosiery and Sweaters; (K) 1 set; 200 spindles; 6 knitting machines; water; sell direct.
- EMPIRE CARPET CO.;** Elizabeth Ether-ington, prop.; J. H. Etherington, mgr.; Ingrains, Art Squares; 16 looms; water.
- PERFECTION KNITTING CO.;** Ltd.; \$2000; (K) B. D. Lubsdorf, sec. and treas.; Alex. D. Chaplin, pres.; Hosiery and Athletic Goods; 3 power machines; hand machines; sell direct.
- STAG DOMINION HAIR CLOTH FACTORY;** C James Prior, prop.; Crinolines, Tailors' Padding and Seatings, Fine Classes of French Goods; gas; dye; sell direct.
- WARREN BROS.;** Full Fashioned Knit (K) Underwear, Cardigan Jackets and Ath-letic Goods, Sweaters, Knitted Gloves; 14 knitting machines; steam; sell direct. (Buy yarn.)
- St. Jacob's.** F-4. G. T. RR.
- GINGRICH, NOAH, W.;** Tweeds, Yarns, (W) Flannels, Blankets; 1 set; 3 looms; 180 spindles; water; dye; sell direct.
- St. John's.** F-5. Next Station Port Rob-inson. N. Y. C. & H. R. RR.
- PITTS BROS.;** Yarns, Tweeds, Flannels, (W) Blankets; 2 sets; 10 looms; 440 spindles; water; dye.
- St. Mary's.** F-3. G. T. RR.
- CLARK & Co.;** Dressed Flax for Export; (F) steam.
- MEYERS, S., & SONS;** S. Meyers and C. (W) Meyers, buyers; Coarse Tweeds, Frieze, Etoffes; 2 cards; 11 looms; steam; dye; A. A. MacDougall & Co., Montreal, s. agts.
- WEIR & WEIR;** Flax and Green Tow; (F) steam.
- Stratford.** F-3. G. T. RR.
- BAKER, H., & Co.;** F. E. Baker, buyer; (W) Wool Stock; 1 set; steam; dye; sell direct.
- DUFTON & SONS;** Stratford Woolen (W) Mills; Tweeds, Friezes, Etoffes; 2 sets; 12 looms; 772 spindles; steam; dye; A. A. MacDougall & Co., Montreal, s. agts. (See also Mitchell.)
- PERTH FLAX & CORDAGE CO.;** Ltd.; \$50,000; N. Richardson, pres.; Walter Mil-ler, sec.; A. H. Raymond, mgr.; Flax, Jute and Hemp, Twines and Rope; Upholster-er's Tow, Yarns for Cordage; sell direct.
- Strathroy.** G-2. G. T. RR.
- GUNN & MURRAY;** Flax Fibre for Spin-ners; steam.
- STRATHROY WOOLEN MILLS;** James (W) Butler, prop.; Tweeds and Flannels; 1 set; 3 looms; 240 spindles; steam.
- Streetville.** F-5. C. P. RR.
- IMPERIAL WOOLEN MFG. CO.;** 8 sets; 42 (W) looms; 2540 spindles; water; dye. *Not running 1900-1901.*
- Tamworth.** D-7. B. of Q. R. & N. Co.
- MITCHELL, D., & SON;** Jno. Mitchell, (W) supt.; Blankets, Tweeds; 1 set; 5 looms; water; dye; sell direct.
- Tara.** D-3. G. T. RR.
- TARA WOOLEN MILL;** J. R. Forbs, buyer; (W) Tweeds, Flannels, Blankets, Yarns; 1 set; 4 looms; steam and water; dye; sell di-rect.
- Tavistock.** F-3. G. T. RR.
- FIELD, J. G.;** Etoffes, Friezes; 1 set; 6 (W) looms; 300 spindles; steam; dye; Duncan Bell, Montreal, W. M. Angus & Co., Tor-onto, s. agts.
- Teeswater.** E-3. C. P. RR.
- PURVIS, P.;** P. Purvis, supt.; Tweeds, (W) Blankets, Sheetings, Yarns; 1 set; 5 looms; steam; dye; W. M. Angus, Toronto, s. agt.
- Thessalon.** (Not shown on map.) C. P. RR.
- CRONKHITE BROS.;** Thessalon Woolen (W) Mills; Tweeds, Flannels, Blankets, Yarns; 1 set; 5 looms; 180 spindles; water; dye; sell direct.
- Thorold.** F-5. G. T.; N. St. C. & T. RR.
- PENMAN MFG. CO.;** Ltd; \$700,000; (W & K) Jno. Penman, pres.; O. R. Whitby, treas.; O. J. Phelps, supt.; Knitted Woolen Un-derwear; 3 sets; 15 knitting machines; water; dye; D. Morrice Sons & Co., Mon-treal, s. agts. (Head office, Paris, which see.)
- Tilsonborough.** G-3. G. T.; M. C.; T. L. E. & T.; W. RR.
- PALMER, JOSEPH & Co.;** Hosiery, Jack-ets, Mitts; 15 knitting machines; sell di-rect.
- Toronto.** F-5. C. P.; G. T. RR.
- CANADA WOOLEN MILLS;** Ltd; \$2,000,000; (W) W. R. Brock, pres.; W. D. Long, vice-pres.; Geo. Davidson, sec. and treas.; mills at Carleton Place, Hespeler, Waterloo, Lamb-ton Mills, Ont.; Millicamp, Coyle & Co., Montreal and Toronto, s. agts.
- HUTCHINSON, SHURLEY & DERRETT;** (F) Cordage, Tennis Nets, Hammocks, Fish Chalk, Mason Lines, Cotton Rope; steam; dye; sell direct. (Buy cotton yarns 2-1/2, 4, 6, 8, 10s, 2/15, 2/20, 2/30s ply.)
- INDEPENDENT CORDAGE CO.;** \$55,000; (F)

- W. C. Bonnell, pres. and mgr.; Geo. High, vice-pres.; H. A. Dewart, sec.; Manilla and Sisal Rope and Binder Twine; steam; 106 spindles; sell direct.
- JONES, CROSLAND & CO.:** Smyrna Rugs; (W) 4 looms.
- MAPLE LEAF WOOLEN MILLS CO.:** mill at Markham, which see.
- MERCHANT'S DYING AND FINISHING, D & F CO.:** Ltd; T. H. Burton, pres.; R. W. Spence, vice-pres.; E. S. Burton, treas.; Alfred Burton, supt.; Dyers and Finishers of all classes of Dress Goods, Cashmeres, Serges, Chevots, Fontes, Meltons, Broadcloths; steam; sell direct.
- PARKER, R. & CO.:** Rob. Parker, (D & F) buyer; Dyeing, Cleaning, Finishing; steam.
- SCOTT, M. E. & CO.:** Specialties in Knit (K) Goods; 10 knitting machines; sell direct. (Buy yarns.)
- SHEA, WM.:** Plain and Ribbed Cotton (K) and Woollen Hosiery; 30 hand knitting machines; 5 ribbing machines; sell direct. (Buy woollen and cotton yarn.)
- SIMPSON, JOSEPH & SONS:** Flat, Ribbed, (K) Fleece and Children's Underwear and Sweaters; 7 sets; 75 knitting machines; steam; dye; sell direct and through Geo. D. Ross & Co., Montreal.
- SMITH WOOL STOCK CO.:** M. T. Smith & (W) Co.; G. A. Smith, supt.; Shoddy; Wool-stock; 4 cards; 4 garnet; 4 picker; steam; dye.
- STANDARD WOOLEN MILLS CO.:** (W & K) \$100,000; Thos. Hook, pres.; W. F. Turnbull, mgr.; R. E. Chapman, sec. and treas.; Blankets, Mackinaws, Knit Shirts and Drawers, Tops, Cardigan Jackets, Sweaters, etc.; 7 sets; 90 looms; 2034 spindles; 21 cylinders; 31 sewing machines; steam; dye; sell direct and through J. C. Donnelly, Montreal.
- TORONTO CARPET MFG. CO.:** Ltd; \$150,000; J. A. Murray, pres.; F. B. Hayes, treas. and buyer; Ingrains, Wools and Union Art Squares, Smyrna Rugs, Administer Carpets; 2 sets; 150 looms; steam; dye; sell direct. (Buy cotton yarns 2/4 in skein, 5/12, 3/16, 2/30 in chain and double reel cotton filling for Ingrains.)
- UNIVERSAL KNITTING MACHINE CO.:** (K) Ltd; \$60,000; Wm. Wilson, pres.; H. F. McIntosh, sec. and treas.; D. H. McKay, mgr. and buyer; Hosiery of Socks and Stockings, Toques, Sweaters; 238 knitting machines; 460 cylinders; steam; dye; sell direct. (Buy yarns for hosiery, cotton 35 to 50s, worsted 15s to 75s.)
- WARREN, THOS.:** Thos. Warren, buyer; (K) Sweaters, Hosiery, Toques, Athletic Goods; 10 knitting machines; sell direct.
- WHITE-ALLEN CO.:** \$20,000; Geo. White, (F) pres., supt. and buyer; A. G. Allen, treas.; Friezes, Cords, Tassels; steam; electricity; dye; sell direct. (Buy cotton yarns 8s to 80s, also linen yarns.)
- Toronto Junction, F-5, C. P. RR.**
- LACES & BRAIDES MFG. CO., THE:** A. J. (C) Gillies, prop.; Fancy Dress Trimmings, Braids, Elastics, Cords and Laces; 300 braiding machines; dye; steam; sell direct. (Buy yarns.)
- Uxbridge, E-5, G. T. RR.**
- ADAMS, GEO.:** Rope and Twine. (F)
- Vienna, (Not shown on map.) T., L. E. & P. RR.**
- CLIFTON, S. S.:** Blankets, Flannels, (W & K) Tweeds, Yarns and Hosiery; 1 set; 5 looms; 264 spindles; 3 knitting machines; water; dye; John Chandler, Toronto, s. agts.
- Walkerton, E-3, G. T. RR.**
- WALKERTON BINDER-TWINE CO.:** Ltd.; (F) \$125,000; R. E. Truax pres.; Jas. Tolton, treas., supt. and buyer; Binder-Twine; water; sell direct. (Buy yarns 16s, gray, bleached and black.)
- Waterloo, F-4, G. T. RR.**
- BAUER, A., & CO.:** G. R. Watson, supt.; (W) Wool Batting and Flocks; 3 pickers; 8 cards; steam; sell direct.
- CANADA WOOLEN MILLS, Ltd.:** W. R. (W) Brock, pres.; John E. Morley, mgr.; Geo. Davidson, sec.; Tweeds, Flannels, Robes; 7 sets; 30 looms; 2400-spindles; steam; dye; Millicamp, Coyle & Co., Montreal and Toronto, s. agts. (Head office, Toronto, which see.)
- Watford, G-2, G. T. RR.**
- LOUCES, S. W.:** Tweeds, Flannels, Blan- (W) kets, Stocking Yarn; 1 set; 4 looms; steam; dye. (Buy cotton warps.)
- Wellesley, F-3, Next station Baden, G. T. RR.**
- WELLESLEY WOOLEN & KNITTING (W & K) MILLS:** J. G. Reiner; Tweeds, Flannels, Hosiery, Fancy Knit Goods, Sweaters, Cardigans, Socks, Horse Blankets, Elder Downs; 2 sets; 5 looms; 35 knitting machines; 880 spindles; 30 ribbing and 15 sewing machines; steam; dye; J. A. Young, Toronto, D. MacNaughton, Montreal, s. agts. (Buy worsted yarns.)
- West Flamboro, F-4, Wentworth Co.**
- CLARK, WM., & SON:** Flannels, Paper (W) Maker's Felts, Tweeds; 2 sets; 15 looms; 650 spindles; steam; water; dye; McDougall & Co., Montreal, s. agts.
- Westport, (Not shown on map.) B., W. & S. ST. M. RR.**
- WESTPORT WOOLEN MILLS CO.:** Joel (W) Clark, mgr.; Tweeds, Blankets, Yarns; 1 set; 5 looms; 360 spindles; water; dye.
- Warton, (Not shown on map.) G. T. RR.**
- WIARTON WOOLEN MILL:** Porter, Leith (W) & Co.; Blankets, Flannels and Yarns; 1 set; 4 looms; 200 spindles; steam; dye; sell direct.
- Wroxceter, (Not shown on map.) C. P. RR.**
- McKELVIE, SAM'L B.:** Tweeds, Drug (W) gets, Yarns, Flannels, Winecys; 1 set; 6 looms; 320 spindles; water; dye. (See also Mildmay.)

## PRINCE EDWARD ISLAND.

- Brudenell River, P. E. I. RR.**
- McLAREN, M.:** Woollens; 1 set; water. (W)
- Charlottetown, P. E. I. RR.**
- CHARLOTTETOWN WOOLEN MILL:** \$70,000; (W) Tweeds; 2 sets; 10 looms; 600 spindles; dye; sell direct.
- Tryon, Next station Albany, P. E. I. RR.**
- TRYON WOOLEN MFG. CO.:** \$50,000; John (W) D. Reid, pres.; S. E. Reid, treas.; John Ward, supt.; Tweeds, Blankets, Flannels, Yarn; 2 sets; 14 looms; 680 spindles; steam and water; dye; sell direct.

## QUEBEC.

- Beauharnois, C-10, G. T.; N. Y. C. & H. R. RR.**
- DOMINION WOOLEN MFG. CO.:** \$150,000; (W) W. C. McIntyre, pres.; E. A. Robert, mg. dir. and treas.; J. R. Berry, supt.; Overcoatings, Friezes, Etoffes, Rugs and Gray Blankets; 6 sets; 58 looms; 1600 spindles; water; dye; sell direct. (Buy cotton yarns.) Office at Montreal.
- ROBERT, J. B.:** Flannels, Etoffes; 2 sets; (W) 4 looms; water; dye.
- Brownburg, C-9, Argenteuil Co.**
- MORRISON BROS.:** Tweeds, Etoffes, Blan- (W) kets, Knitting Yarn; 2 sets; 4 looms; water; dye; sell direct.

**Cape St. Ignace.** A. Int'l RR.

METHUET, E., & Co.; Tweeds, Flannels, **W** Blankets, Yarns; 2 sets; 8 looms; 400 spindles; steam; dye; sell direct.

**Chambly Canton.** C-I. C. V. RR.

WILLET, S. T.; Richelieu Woolen Mills; **W** A. Sheriff, mgr.; S. Moore, supt.; Dress Goods, Tweeds, Plain and Fancy Flannels and Flannellettes; 10 sets; 61 looms; 440 spindles; water; dye; Geo. S. Plow, Montreal, s. agt. (Buy 2-22 worsted yarn.)

**Chicoutimi.** (Not shown on map.) Qu. & L. St. I. RR.

TALBOT & GIRARD; Chicoutimi Woolen **W** Mill; Blankets, Homespuns, Yarns, Etofes; 1 set; 5 looms; 440 spindles; electric power; dye; sell direct.

**Coaticook.** C-I2. G. T. RR.

CASCADE NARROW FABRIC CO.; W. N. Wyman, pres.; E. F. Tomkins, treas., agt. and buyer; Braids and Tapes; water; dye. (Buy yarns; cotton, 2/12, 2/20, 2/36, 2/40; worsted, 2/16, 2/32.)

COATICOOK WOOLEN CO.; P. H. Arm-itage; Tweeds, Yarns, Blankets and Shawls; 1 set; 4 looms; water; dye; sell direct.

PENMAN MFG. CO.; Ltd; Coaticook (**K** Branch; John Penman, pres.; Oliver R. Whibly, treas.; J. B. Henderson, gen. mgr.; J. J. Fiske, supt.; SHIRTS, Drawers, Fleece and Ladies' Underwear; 6 sets; 1440 spindles; 50 knitting machines; 60 sewing machines; water; dye; D. Morrice, Sons & Co., Montreal, s. agts. (See also Paris, Ont.) (Buy 24 cotton yarn.)

**Drummondville.** (Not shown on map.) C. P.; Int'l RR.

WATTS, W. J.; Yarns, Flannels, Tweeds **W** and Blankets; 1 set; 3 looms; 120 spindles; water; dye.

**Frelighsburg.** (Not shown on map.)

HARVEY & HUNTER; Flannels, Tweeds, **W** Yarns; 1 set; 4 looms; 240 spindles; water; dye.

**Hochelega.** C-II. C. P.; M. P. & I. RR.

HOCHELAGA COTTON MILLS; Dominion **C** Cotton Mills Co.; B. Mole, gen. mgr.; Shirts, Print Cloth, Gray and White Sheetings, Dress Goods, Bags, Ducks, Drills, Quilts, Canton Flannels, Colored and Single Yarns; 00,000 spindles; 1973 looms (including Hudson and St. Anne's Mills); steam and water; dye; Stevenson & Blackader, s. agts. (See also Montreal.)

**Hull.** C-S. C. P.; H. & A.; O. & C. RR.

HANSON, GEO. E.; Yarns, Hosiery and **W & K** Pulp Felts; 1 set; 2 looms; 500 spindles; 6 knitting machines; steam; dye; Geo. R. Lyon & Co., Ottawa, s. agts.

**Joliette.** (Not shown on map.) C. P.; G. N. RR.

GILMOUR WOOLEN MILL CO.; Ft. **W & K** offes, Yarns, Flannels, Tweeds, Mitts, Hosiery; 1 set; 2 looms; 300 spindles; 2 knitting machines; water; dye.

**La Chute Mills.** C-9. Argentin Co.

HAMILTON & AYRES; T. H. Ayres, treas.; **W** agt. and supt.; J. T. Griffith, supt.; Paper and Pulp Maker Felts; 1 sets; 14 looms; sell direct.

**Levis.** (Not shown on map.) G. T.; Int'l Qu. C. RR.

LEVIS KNITTING CO.; \$5000; Chas. Gray, **K** mgr.; J. B. Boutin, treas.; Cotton and Woolen Plain, Rib and Cut Hosiery; 8 knitting machines; sell direct.

**Magog.** C-I2. C. P. RR.

MAGOG COTTON CO.; Dominion **HI, C, Pr** Cotton Mills Co.; A. F. Gault, pres.; C. E. Hanna, sec. and treas.; B. Mole, gen. mgr.; Print Cloths, Linings and Fancies;

47,500 spindles; 1200 looms; 8 printing machines; water; dye; sell direct; Stevenson & Blackader, s. agts. (See also Montreal.)

**Montmorency Falls.** A-12. Qu. RR.

MONTMORENCY COTTON MILLS CO.; Mont. **C** morency Mills; \$750,000; C. R. Whitehead, pres.; L. G. Craig, sec. and treas.; Aut. Mailloux, supt.; Sheetings, Carpet Filling and Warps; 600 looms; 20,952 ring, 3042 mule spindles; water; sell direct.

MONTMORENCY COTTON MILLS CO.; **C & W** Riverside Mill; Ed. Linskey, supt.; Hosiery and Knitting Yarns, Towelling and Blankets; 16 woolen sets; 200 looms; 5440 ring, 14,450 mule, 3360 woolen spindles; water; dye; sell direct.

**Montreal.** C-10. C. P.; G. T.; M. & G. C.; N. Y. C. & H. R.; S. Sh. RR.

BELDING, PAUL & Co.; Ltd; \$370,000; **S** Frank Paul, pres. and treas., also buyer; W. V. McNally, supt.; Silk Threads and Ribbons; steam and water; dye; sell direct. (Buy spun silk yarns all sizes; cotton yarns 2/30, 2/40, 2/60, 2/80.)

BRITISH AMERICAN DYEING CO.; Joseph **D** Allen, prop.; General Piece Goods and Jobbery Dyers in Silk, Wool, Mixed or Cotton Goods.

CANADIAN COLORED COTTON MILLS CO.; **C** Ltd; \$2,700,000; D. Morrice, pres.; C. D. Owen, vice-pres. and gen. mgr.; A. Bruce, sec. and treas.; Mills at Milltown, N. B., Merriford, Cornwall, Hamilton, Ont., Marysville, N. B.; D. Morrice, Sons & Co., s. agts.

CANADA JUTE CO.; Ltd; \$100,000; G. A. **J** Drummond, pres.; Francis Bradford, mgr.; Bagging, Hessians, Sacking, Twine; steam; F. F. Barr, Toronto; E. Nicholson, Winnipeg, s. agts.

COLONIAL BLEACHING & PRINT. **(Pr. D, BI** ING Co.; \$500,000; H. S. Holt, pres.; P. C. Shannon, treas.; A. W. Cochrane, agt.; John Walker, supt. and buyer; Printed and Dyed Cotton Fabrics; steam and electricity; dye; sell direct.

CONSUMER'S CORDAGE CO.; Ltd; \$1,500,000; **J** E. M. Fulton, pres.; H. L. Rutherford, treas.; Manila, Sisal, Russian and Jute Cordage and Twine, Binder Twines; steam and water; Mills at Montreal, Halifax, N. S., St. John, N. B.

**DENON, COLIN C.** Hosiery. **K**

DOMINION BAG CO.; Ltd; \$125,000; E. M. **J** Fulton, pres.; H. L. Rutherford, treas. and gen. mgr.; Jute and Cotton Bags; steam and water.

DOMINION CORD & TASSEL CO.; A. Levin; **S** Dress and Cloak Trimmings, Fringes, Cords, Tassels; electric power. (Buy cotton yarn 4, 8, 16.)

DOMINION COTTON MILLS CO.; **C BI Pr** Ltd; \$324,000; A. F. Gault, pres.; C. E. Hanna, sec.; L. G. Craig, treas.; A. B. Mole, gen. mgr.; F. P. Webster, buyer; Gray and Bleached Cottons, Yarns and Printed Goods; 91,354 mule, 112,386 ring spindles; 5139 looms; electricity, steam and water; Stevenson, Blackader & Co., s. agts.; Mills at Hochelega, Magog, Kingston, Brantford, Moncton, N. B., Halifax, Windsor, N. S., which see.

DOMINION WADDING CO.; Ltd; \$200,000; **C** H. A. Stearns, treas. and supt.; H. F. Stearns, sec.; cuttings and Waddings; 35 cards; steam; dye; Robert Henderson & Co., Montreal, s. agt.

EXCELSIOR WOOLEN MILLS; \$200,000; **W** A. F. Gault, pres.; S. H. McDowell, sec. and treas.; S. J. Moore, supt.; Worsteds, Beavers, Cover Cloth, Ladies' Dress Goods, Tweeds; 8 sets; 39 looms; 3500 spindles; steam; dye; Stevenson, Blackader & Co., s. agts. (Buy 16/2 to 60-2 worsted yarn.)

FRASER, ROBERT S.; Garnetted Wastes **W** and Shoddies; 3 Garnetts; 2 cards; 2 pickers; water; dye.

- GARAYT, H.:** Woolen and Worsted Hosiery, Jerseys, Toques, Mitts, Bicycle Hosiery, 22 knitting machines; electricity; sell direct. Buy yarns, worsted 2/10/4 and 5s, 3/10, 3/12; woolen 1/14, 2/28, 2/30, cashmeres, 3/24s, 4/24s, 3/16, 2 16s.)
- HUDSON BAY KNITTING CO.:** \$50,000; **W** J. J. Westgate, pres. and mgr.; R. Lucas, sec. and treas.; John Oniellette, supt.; Socks, Gloves, Mitts; 10 knitting, 75 sewing machines; steam; sell direct. (Buy yarn 10s to 70s.)
- LACOTTE, J. B. A.:** Gloves, Mitts; 15 **K** hand machines.
- LAROQUE, A.:** Plain and Ribbed Hosiery and Damask; 2 looms; 35 hand knitting machines; Williams & Bell, s. agt., and direct. Buy cotton and woolen yarns.)
- MERCHANTS' COTTON CO.:** \$1,500,000; Jas. C. Crathern, pres.; Wm. G. Cheney, treas.; Fred Hawksworth, gen. mgr. and buyer; Bleach and Gray Cottons and Shirtings, Sheetings, Denims, Hosiery Yarns; 64,520 mule, 46,240 ring spindles; 2559 looms; steam; dye; sell direct.
- MONTREAL BLANKET CO.:** see St. Paul. **W**
- MONTREAL HORSE CLOTHING CO.:** E. M. **W** Heney & Co.; Blanket and Rugs; electric power; sell direct.
- MONTREAL KNITTING CO.:** Hy. Poirier, **K** supt.; Cashmere Seamless Hosiery; 9 knitting, 4 sewing machines; dye; W. Williams & Co.; Montreal, s. agts. (Buy yarn.)
- MONTREAL WOOLEN MILL CO.:** \$200,000; **W** R. L. Gaunt, pres.; J. H. Horsfall, treas., supt., buyer; Tweeds, Friezes, Coatings, Blankets, Rugs; 6 sets; 35 looms; water and steam; dye; W. R. Morson, Montreal, s. agts.
- MONTFON & CO.:** Montreal Fringe and **S** Tassel Works; Cords, Braids, Tassels, Fringes; electricity; sell direct. Buy yarns; cotton ss, 16s; woolen, "Shotland," 15 2, 1s 2; genapped worsted 2 8, 2 20, 2 32; genapped mohair, 2 32, 2 40.
- NEUBOLD BROS.:** Worsted Seamless and **K** Bicycle Hosiery, Mitts, Sashes; 20 knitting, 17 ribbing, 1 sewing machines; sell direct. (Buy yarn.)
- STAR KNITTING & HOSIERY CO.:** Chas. **K** Massey, supt.; Men's and Women's Hosiery, Mitts, Toques, Quilted Linings; 3 quilting, 40 hosiery and 7 embroidery machines; electric power; sell direct.
- YOUNG, J. & G. H. & CO.:** Cotton, Wool-**K** en and Worsted Hosiery; 75 knitting and 5 sewing machines; electric power; sell direct. Buy woolen and worsted yarns.
- Sherbrooke, C-12, B. & M.:** C. P.; G. T.; Qu, C. RR.
- DOMINION CARPET CO.:** \$70,000; C. Stew-**W** art Cox, pres.; E. W. Randle, sec. and treas.; W. S. Dresser, mgr. dir.; Brussels, Wilton, Tapestry, Velvet and Ingrain carpets, Rugs, Yarns; water; dye.
- GRINDROD, A. L. & CO.:** Magog Woolen **W** Mills; Tweeds, Flannels, Blankets, Yarn; 2 sets; 9 looms; water; dye; W. M. Angus & Co., Toronto, Holland & Haskell, Montreal, s. agts.
- LOMAS, ADAM & SON:** Walter Oliver, **W** supt.; Flannels, Dress Goods, Medium Tweeds; 5 sets; 20 looms; water; dye; W. M. Angus & Co., Toronto, Holland & Haskell, Montreal, s. agts. (Buy cotton yarns 2 40s.)
- PATON MFG. CO.:** \$600,000; R. W. **W** & **K** Hencker, pres.; John Turnbull, mang. dir.; J. E. Boswell, sec.; W. W. Cullock, mgr.; Woolens and Woolen Yarns, Tweeds, Cashmeres, Overcoatings; 22 sets; 106 broad and 8 narrow looms; 5 worsted combs; 5 worsted cards; 6 cylinders; water; dye; sell direct.
- St. Hyacinthe, C-11, C. P.:** G. T.; Int'el; Qu, S. RR.
- CANADIAN WOOLEN MILLS CO.:** (**W** & **K** \$1,500,000; J. G. Cannon, pres.; J. Laframboise, treas.; M. Boas, agt. and buyer; Chas. Boughton and A. Balantyne, supts.); Knitted Goods and Tweeds; 8 sets; 170 knitting machines; 32 looms; water and steam; dye; sell direct. (Buy yarns, cotton 10s to 40s; worsted cashmere 17s to 56s).
- St. John's, C-11, C. P.:** C. V.; G. T.; S. Qu, RR.
- CORTICELLI SILK CO., Ltd.:** \$125,000; Tra **S** Dimoch, pres.; W. H. Wynman, treas.; C. J. Brown, supt.; Silk Braids, Laces, Threads, Embroideries, Twists, Linings, Fish Lines, Chenille; 2000 spindles; 10 looms; 75 bradders; steam; dye; sell direct.
- MOLLEUR, J. E.:** Shirts, Drawers; 3 (**W** & **K** sets); 1540 spindles; 6 knitting, 1 ribbing and 14 sewing machines; steam; dye; sell direct.
- VICTORIA HOSIERY CO.:** Gervais & Bros.; **K** Ribbed and Plain Hosiery, Mitts and Felt Boots; 40 knitting and 2 felt machines; steam; sell direct.
- St. Paul, (Not shown on map.)** G. T.; M. P. & I. RR.
- MONTREAL BLANKET CO.:** \$30,000; J. R. **W** Walker, pres.; E. E. Fox, treas.; R. Brooke, mgr.; Shoddies and Flocks; 8 sets; 2 garnett machines; 6 pickers; steam and water; dye; sell direct, and through J. R. Walker, Montreal.
- Three Rivers, B-11, C. P. RR.**
- CANADIAN WEB CO.:** P. V. Ayott, prop.; **C** Suspender and Garter Webs and Braids; 7 looms; 14 bradders; steam; dye; sell direct. (Buy 10 to 60 2 ply yarn.)
- Thurso, C-9, C. P. RR.**
- BLACK, J. & G.:** John Hunt, supt.; **W** Tweeds, Friezes, Flannels, Blankets, Shawls, Yarns; 1 set; 3 narrow and 2 broad looms; 380 spindles; water; dye; sell direct.
- Trenholville, C-12, Drummond Co.**
- TRENHOLVILLE WOOLEN MILL:** **W** & **K** John Hall; Tweed Blankets, Flannels, Yarns; 1 set; 5 looms; 200 spindles; 3 knitting machines; water; dye; sell direct.
- Valleyfield, C-10, C. A.:** G. T.; N. C. & H. R. RR.
- MONTREAL COTTON CO.:** \$2,500,000; A. F. **C** Gault, pres.; D. F. Smith, sec. and treas.; Fred Lacey, mgr.; L. J. Young, supt.; Dress Goods, Linings and Upholstery Goods, Yarns 20s to 50s; 18,000 mule and 18,432 ring spindles; 900 looms; water; dye; Stevenson Blackader, Montreal, s. agt.
- Waketield, C-8, O. & G. RR.**
- MAC LAUREN, ALEXANDER:** George Ime; **W** son, supt.; Elofies, Kersseys, Flannels, Blankets; 1 set; 6 looms; water; dye; sell direct.
- Waterloo, C-11, C. P.:** C. V. RR.
- WATERLOO KNITTING MILLS:** \$30,000; A. **K** F. Savarie, mgr.; Shirts and Drawers; 3 sets; 7 2 spindles; 15 knitting machines; steam; Donald Fraser, Montreal, s. agt.
- Way's Mills, C-12, Stanstead Co.**
- BARNSTON WOOLEN MILL CO.:** A. H. Dy; **W** son, supt. and buyer; Tweeds, Flannels, Yarns, Horse and Bed Blankets, Shawls and Lap Robes; 1 set; 3 looms; water; dye; sell direct.
- Yamachiche, B-11, C. P. RR.**
- DELISLE, A. & G. L.:** Tweeds, Flannels, **W** Blankets, Yarns; 3 sets; 8 looms; 900 spindles; water; dye; sell direct.

# ALPHABETICAL INDEX

—TO—

## The Textile Establishments

OF THE UNITED STATES.

The following index is an alphabetical arrangement of all the textile establishments in the United States. Following the name and address of the establishment, the character of the mill is designated by letters; thus,

(C) means a cotton mill      (K) means a knitting mill      (Bl) means a bleachery  
(W) means a woolen mill      (Fl) means a flax mill      (F) means finishing establishment  
(S) means a silk mill      (D) means a dye works      (J) means a jute mill

The *number* which follows indicates the *page* upon which the full particulars of the mill will be found.

It frequently happens that an establishment is listed under two names; viz., proprietor's and company's name and also the name of the mill, as, for example, E. V. Pike; Sunnyside Mills, Cheltenham, Pa. In the alphabetical index this is listed as follows: Pike, E. V., Cheltenham, Pa., also under the head of Sunnyside Mills (E. V. Pike), the page number being given in both instances, but in the case of the second name the address is not given, so that if this index is used for addressing purposes, no duplicates will be made if directed only to the names which *have addresses*.

As the body of the Directory is arranged alphabetically by states, towns and establishments, it is, therefore, self-indexing, and any mill can readily be found through one or the other system of classification, viz., by its name in the alphabetical index or by its location in the body of the book, where full particulars about each mill will be found.

- Abbeville Cotton Mills, Abbeville, S. C. (C) 262.  
Abbott, Amos & Co., Dexter, Me. (W) 103.  
Abbott Mfg. Co., Philadelphia, Pa. (W) 202.  
Abbott Worsted Co., Graniteville, Mass. (W) 119.  
Aberdeen Cotton Mills, Aberdeen, Miss. (C) See  
Too Late for Classification.  
Aberfoyle Mfg. Co., Chester, Pa. (C & W) 235.  
Aberle, Harry C. & Co., Philadelphia, Pa. (K) 202.  
Abiet, Robt., Whitesboro, N. Y. (K) 184.  
Achuff Knitting Mills (Samuel Achuff) 202.  
Achuff, Samuel, Philadelphia, Pa. (K) 202.  
Ackerman, H. K., Paterson, N. J. (S) 154.  
Ackerman, W. M. & Bro., Philadelphia, Pa. (K) 202.  
Acme Bleaching Co., Allentown, Pa. (Bl & D) 231.  
Acme Hosiery Co., Rochester, N. Y. (W) 179.  
Acme Woolen Mill, Cleveland, Ohio (W) 198.  
Acorn Web Works, The, North Wales, Pa. (C) 243.  
Acuman, E. A., Fordyce, Ark. (W) 71.  
Active Knitting Mills, Reading, Pa. (K) 214.  
Acushnet Mill Corp., New Bedford, Mass. (C) 126.  
Ada Mfg. Co., Charlotte, N. C. (C) 185.  
Adams Bros., Boston, Mass. (C) 112.  
Adams Bros. Mfg. Co., Adams, Mass. (C) 109.  
Adams, D. E., Athol, Mass. (S) 111.  
Adams, H. H., Holmesville, O. (W) 199.  
Adams, J. F. (Adams'ale Mill) 109.  
Adams, Joseph M., Philadelphia, Pa. (W) 202.  
Adams Kilmarx Co., The, New York, N. Y. (S) 172.  
Adams Print Works Co., Malden, Mass. (Pr) 121.  
Adams, R. F., Shelton, Conn. (C) 79.  
Adamsdale Mill, Adamsdale, Mass. (C) 109.  
Adamson, Jos. & Co., Philadelphia, Pa. (C) 202.  
Adamstown Hosiery Mill (Pierce Mohn) 231.  
Adeock, Joseph, Philadelphia, Pa. (K) 202.  
Adeock, J. C. Bros. & Co., Pottsville, Pa. (K) 244.  
Adelaide Mills, Anniston, Ala. (C) 67.  
Adelaide Mills (Phoenix Silk Mfg. Co.) 231.  
Adhesive Gimp Co., New York, N. Y. (S) 173.  
Adrian Knitting Co., The, Adrian, Mich. (K) 135.  
Aetna Cotton Mills, Union, S. C. (C) 267.  
Aetna Ktg. Co., Worcester, Mass. (K) 134.  
Aetna Mills, Watertown, Mass. (W) 133.  
Aetna Silk Co., Norfolk, Conn. (S) 78.  
Agan, F. W., Ludlow, Vt. (W) 275.  
Agawam Co., Agawam, Mass. (W) 111.  
Agnew, Geo. & Sons, Trenton, N. J. (W) 159.  
Ahlstrom-Ashworth Co., Jamestown, N. Y. (W) 170.  
Aiken Mfg. Co., Bath, S. C. (C) 262.  
Aiken's, Walter, Sons, Franklin Falls, N. H. (K) 143.  
Aikman, C. M. & Co., Brooklyn, N. Y. (C & S) 164.  
Aikman, Jas. J., Pottsville, Pa. (K) 244.  
Aiman Richard H., Philadelphia, Pa. (W) 202.  
Airlie Mills, Hanover, Conn. (W) 75.  
Ajax Textile Co., Weatherford, Texas (W) 272.  
Aken Ktg. Co., The, Philmont, N. Y. (K) 179.  
Akers & Taylor, Charlton City, Mass. (W) 113.  
Akron Twine & Cordage Co., Akron, O. (FD) 197.  
Alabama Cordage Co., Montgomery, Ala. (C) 69.  
Alamance Factory, Burlington, N. C. (C) 184.  
Alabama Mills (Dwight Mfg. Co.) 67.  
Albany Felt Co., Albany, N. Y. (W) 161.  
Albany Linen Mills, Albany, Wis. (Fl) 280.  
Albany Woolen Mills, Albany, Ore. (W) 201.  
Alberton Cotton Mills (J. S. Gary & Sons) 107.  
Albion Carpet Mills (Jas. & Geo. D. Bromley) 205.  
Albion Co., Mt. Holly, N. C. (C) 193.  
Albion Dye & Bleach Works (G. J. Littlewood & Sons, Ltd.) 220.  
Albion Knit Goods Co., Utica, N. Y. (K) 182.  
Albion Woolen Mills (Wm. Thornton) 231.  
Albrecht, C. H. & Co., Cincinnati, Ohio (S) 197.  
Albuquerque Wool Scouring Mills, Albuquerque, New Mexico (W) 160.  
Alcorn Woolen Mfg. Co., Corinth, Miss. (W) 140.  
Alden Knitting Mills, New Orleans, La. (C) 102.  
Alden Knitting Mills Co., Paducah, Ky. (K) 101.  
Aldrich Mfg. Co., Moosup, Conn. (C) 77.  
Aldrich Ktg. Co., Charlton City, Mass. (W) 113 and  
Too Late for Classification List.  
Alexander, Andrew, Philadelphia, Pa. (W) 202.  
Alexander Blanket Co., Cossayuna, N. Y. (W) 168.  
Alexander City Mills, Alexander City, Ala. (C) 67.

- Alexander Dye Works, Lodi, N. J. (D, F & Pr) 152.
- Alexander, L., Canton, Ohio (W) 197.
- Alexander Silk Mills, Passaic, N. J. (S) 153.
- Alexandria Ktg. Mills, Alexandria, Va. (K) 276.
- Algonquin Co., The, Passaic, N. J. (W) 153.
- Algonquin Printing Co., Fall River, Mass. (Pr) 116.
- Allegheny Dye Works (Brehm & Stehle) 205.
- Allegheny Worsted Mills (Thos. Wolstenholme, Sons & Co.) 230.
- Allen, Alexander, Baldwinsville, N. Y. (K) 163.
- Allen Dyeing Co., The, Philadelphia, Pa. (D & B) 202.
- Allen, J. & B., Philadelphia, Pa. (K) 202.
- Allen, J. & S., Walpole, Mass. (Fl) 132.
- Allen Knitting Co., Churchtown, Pa. (K) 235.
- Allen, Wm. & Son, Philadelphia, Pa. (W) 202.
- Allen, W. A., Dr., Billings, Mont. (W) 142.
- Allen Woolen Mills, Rochester, N. Y. (W) 180.
- Allendale Co., No. Providence, R. I. (C) 255.
- Allen's, D. Sons, Rope Co., Brooklyn, N. Y. (J) 164.
- Allen's Mill (Alexander Allen) 163.
- Allen's Print Works, Providence, R. I. (Pr) 257.
- Allentown Hosiery Co. (H. Gabriel's Sons) 231.
- Allentown Knitting Co., Allentown, Pa. (K) 231.
- Allentown Silk Co., Allentown, Pa. (S) 231.
- Allentown Spinning Co., Allentown, Pa. (J) 231.
- Alliance Knitting Mills, Whitesboro, N. Y. (K) 184.
- Alliance Silk Mill, Weehawken, N. J. (S) 159.
- Alting, A. H. & C. B., Derby, Conn. (K) 73.
- Allison, G. F. & Co., Utica, N. Y. (W) 182.
- Alloway Knitting Mills, Alloway, N. J. (K) 148.
- Alma Woolen Mill, Alma, Mich. (W) 135.
- Alpena Woolen Mill Co., Alpena, Mich. (W) 135.
- Alpha Cotton Mills, Jonesville, S. C. (C) 266.
- Alpha Ktg. Co., Schenectady, N. Y. (K) 180.
- Alpine Cotton Mills, Morgantown, N. C. (C) 193.
- Alpine Knitting Co., Pittston, Pa. (C) 243.
- Alpine Woolen Mills, Mt. Airy, N. C. (W) 193.
- Alsbaugh Cotton Mill, Taylorsville, N. C. (C) 196.
- Alsbaugh, U. L. (Alsbaugh Cotton Mill) 196.
- Altamahaw Cotton Mills (Holt, Gant & Holt) 188.
- Alter, Wesley (Union Knitting Mill) 181.
- Altman Woolen Mills, Clarks, O. (W) 198.
- Altshuler Bros. (New York & Brooklyn Silk Mfg.) 157.
- Altshuler, Leon, New York, N. Y. (S) 173.
- A. & M. Specialty Mfg. Co., Phenix, R. I. (C) 257.
- Amana Society Woolen Mills, Amana, Iowa (W) 98.
- Amazon Knitting Co., Muskegon, Mich. (K) 138.
- Amber Carpet Mills (C. H. Masland & Sons) 231.
- Ambler, Joseph, Mt. Pleasant, Mich. (W) 138.
- American Braid Co., Paterson, N. J. (W & S) 154.
- American Buffalo Robe Co., Buffalo, N. Y. (W) 166.
- American Chemical & Textile Coloring Co., Wilmington, N. C. (D) 196.
- American Circular Loom Co., Chelsea, Mass. (C) 113.
- American Cotton Spinning Co., Denison, Texas (C) 272.
- American Dye Works (J. Schweigart) 226.
- American Electrical Works, Providence, R. I. (C) 257.
- American Felt Co., Glenville, Conn.; Franklin and Norfolk, Mass.; Picton, N. J.; Dolgeville and New York, N. Y. (W) 75, 119, 127, 158, 168, 173.
- American Fire Hose Mfg. Co., Chelsea, Mass. (C) 113.
- American Flax Co., Indian Orchard, Mass. (Fl) 121.
- American Flax Fibre Co., Austin, Minn. (Fl) 139.
- American Hair Cloth Co., Pawtucket, R. I. (C) 255.
- American Hosiery Co., New Britain, Conn. (K) 77.
- American Knitting Co., Waltham, Mass. (K) 132.
- American Knitting Co., Honesdale, Pa. (K) 239.
- American Knitting Mills (Henry Gernshym & Bro.) 164.
- American Linen Co., Fall River, Mass. (C) 116.
- American Mfg. Co., St. Louis, Mo.; Brooklyn and New York, N. Y. (J) 142, 162, 164, 171, 173.
- American Mills Co., Rockville and Waterbury, Conn. (W) 79, 81.
- American Multiple Fabric Co., Providence, R. I. (C) 257.
- American Narrow Fabric Co., Reading, Pa. (C) 244.
- American Net & Twine Co., Anniston, Ala., and Boston, Mass. (C) 67, 112.
- American Novelty Printing & Embossing Works, New York, N. Y. (Pr, D & F) 173.
- American Printing Co., Fall River, Mass. (Pr) 116.
- American Separator Rope Co., Philadelphia, Pa. (C) 202.
- American Shawl Co., Paterson, N. J. (W) 154.
- American Shirt & Hosiery Co. (E. Emmers & Co.) 246.
- American Shoe Lace Co., Providence, R. I. (C) 257.
- American Silk Dyeing & Finishing Co., Hawthorne, N. J., and New York City (Pr, D & F) 151, 173.
- American Silk Label Mfg. Co., New York, N. Y. (S) 173.
- American Silk Mfg. Co., Eden, Pa. (S) 237.
- American Spinning Co., Greenville, S. C. (C) 265.
- American Textile Co., Philadelphia, Pa. (K) 202.
- American Textile Co., Pawtucket, R. I. (C) 255.
- American Textile Waterproofing Co., Hawthorne, N. J. (D) 151.
- American Thread Co., New York, N. Y. (C) 173.
- American Tubing & Webbing Co., Providence, R. I. (C) 257.
- American Velvet Co., Stonington, Conn. (S) 80.
- American Warehouse Co., Spray, N. C. (F) 195.
- American Woolen Co., Boston, Mass. (W) 112.
- American Yarn Mfg. Co., Pawtucket, R. I. (C) 255.
- American Yarn Print Works (John Forrest) 215.
- Amherst Knitting Co., Philadelphia, Pa. (K) 203.
- Amidon, Chas. J. & Sons, Hinsdale, N. H. (W) 145.
- Ammen, M. T., Fincastle, Va. (W) 276.
- Ammon, E. S., Reading, Pa. (K) 244.
- Amory Mfg. Co., Manchester, N. H. (C) 146.
- Amoskeag Mfg. Co., Manchester, N. H. (C) 146.
- Ampere Silk Mill (W. K. Underhill) 148.
- Amsterdam Ktg. Co., Amsterdam, N. Y. (K) 161.
- Amsterdam Silk Mills, Hoboken, N. J., and Amsterdam, N. Y. (S & K) 151, 161.
- Amsterdam Woolen Co., Amsterdam, N. Y. (W) 161.
- Amstutz, Welty & Co., Pandora, Ohio (W) 200.
- Anatolian Rug Mfg. Co., Philadelphia, Pa. (W) 202.
- Anawamscott Mills, Drownville, R. I. (D & F) 253.
- Anchor Duck Mill, Rome, Ga. (C) 91.
- Anchor Hosiery Mills, Cohoes, N. Y. (K) 166.
- Anchor Knitting Mills, Haganan's Mills, N. Y. (K) 169.
- Anchor Knitting Mills (Robt. Ablett) 184.
- Anchor Mills, Huntersville, N. C. (C) 190.
- Anchor Mills, Harrisville and Pascoag, R. I. (W) 254, 255.
- Anchor Woolen Mills, Maryville, Tenn. (W) 270.
- Anderson Bros., Paterson, N. J. (S) 154.
- Anderson Cotton Mill, Monticello, Ark. (C) 71.
- Anderson Cotton Mills, Anderson, S. C. (C) 262.
- Anderson, E. K. & G. N., Ashland, Ore. (W) 201.
- Anderson Mills, Skowhegan, Me. (W) 166.
- Andreas, Chas. & Sons (Yale Woolen Mills) 139.
- Andrews, Albert J., Anthony, R. I. (C) 251.
- Andrews & Smith Woolen Co., Norwalk, Conn. (W) 78.
- Androsoggin Mills, Lewiston, Me. (C) 103.
- Angola Dyeing Co., Philadelphia, Pa. (D) 203.
- Angora Knitting Co., Detroit, Mich. (K) 137.



- Angora Mfg. Co., Philadelphia, Pa. (W) 203.  
 Angora Mill No. 2 (Angora Mfg. Co.) 203.  
 Angora Mills (Albert Callaghan) 209.  
 Annabessacook Mills, No. Monmouth, Me. (W) 105.  
 Annetstown Cotton Mill, Atlanta, Ga. (C & K) 85.  
 Annis Cotton Mills, McMinnville, Tenn. (C) 270.  
 Anniston Carpet Co., Anniston, Ala. (W) 67.  
 Anniston Cordage Co., Anniston, Ala. (C) 67.  
 Anniston Knitting Mills, Anniston, Ala. (K) 67.  
 Anniston Mfg. Co., Anniston, Ala. (C) 67.  
 Anniston Yarn Mills, Anniston, Ala. (C) 67.  
 Ansonia Brass & Copper Co., Ansonia, Conn. (C) 72.  
 Ansonia, O. & C. Co., Ansonia, Conn. (C) 72.  
 Appel Bros. Mfg. Co., Paterson, N. J. (S) 154.  
 Appleton Co., Lowell, Mass. (C) 122.  
 Appleton Knitting Co., Appleton, Wis. (K) 280.  
 Appleton Woolen Mills, Appleton, Wis. (W) 280.  
 Appollo Woolen Mills, Ltd., Appollo, Pa. (W) 231.  
 Aragon Mills, Aragon, Ga. (C) 85.  
 Aramingo Dyeing, Finishing & Printing Works (S. Penderbury & Son) 222.  
 Aramink Carpet Mills (James Hall) 235.  
 Aranseia Mfg. Co., Philadelphia, Pa. (F1 & L) 203.  
 Arasapha Mills (Jordan Mfg. Co.) 235.  
 Arcade Cotton Mills, Rock Hill, S. C. (C) 267.  
 Arcola Mills (Joseph M. Adams) 202.  
 Arctic Mills, River Point, R. I. (C) 259.  
 Argo Knitting Co., Utica, N. Y. (K) 182.  
 Argo Mills Co., Gloucester City, N. J. (C) 149.  
 Argonaut Cotton Mill Co., Covington, Ky. (C) 100.  
 Arista Cotton Mills, Winston-Salem, N. C. (C & W) 196.  
 Arkansas Woolen Mills, Nashville, Ark. (W) 71.  
 Arkonia Mfg. Co., Philadelphia, Pa. (C, W & S) 203.  
 Arkwright Mills, Fall River, Mass. (C) 116.  
 Arkwright Mills, Spartanburg, S. C. (C) 267.  
 Arlington Cotton Mills, Gastonia, N. C. (C) 189.  
 Arlington Cotton Mills, Arlington, S. C. (C) 262.  
 Arlington Embroidery Co., New York, N. Y. (S) 172.  
 Arlington Mills, Lawrence, Mass. (C & W) 121.  
 Arnbruster, William, Columbus, O. (K) 198.  
 Armitage, David & Son, Chester, Pa. (W) 235.  
 Armit, James & Son, Paterson, N. J. (S) 154.  
 Armstrong Braiding Co., Sandwich, Mass. (S) 130.  
 Armstrong Knitting Co., Charlottesville, Va. (K) 275.  
 Armure Tapestry Mill, Philadelphia, Pa. (C) 203.  
 Arnold, A. & Co., New York, N. Y. (S) 173.  
 Arnold Print Works, North Adams, Mass. (C, Bl, D & Pr) 127.  
 Arnold, W. O. & L. W. (Westerly Woolen Co.) 260.  
 Arnot Wool Co., Las Vegas, New Mex. (W) 160.  
 Arohnson, Samuel J., Paterson, N. J. (S) 154.  
 Aronsohn & Bloom, Paterson, N. J. (S) 154.  
 Arrowanna Mills, Middletown, Conn. (C) 76.  
 Art Knitting Mill, Philadelphia, Pa. (K) 203.  
 Artman Treichler Carpet Co., The E. R., Philadelphia, Pa. (W) 202.  
 Ascher, Simeon, New York, N. Y. (K) 172.  
 Ashaway Line & Twine Mfg. Co., Ashaway, R. I. (C) 251.  
 Ashaway Woolen Co., Ashaway, R. I. (W) 251.  
 Ashburnham Sheering Mill, Fitchburg, Mass. (C) 118.  
 Ashby Cotton Mills, Marlon, S. C. (C) 266.  
 Ashcroft Cotton Mills, Florence, Ala. (C) 67.  
 Asheville Cotton Mills, Asheville, N. C. (C) 181.  
 Ashland Co., So. Scituate, R. I. (C) 259.  
 Ashland Cotton Co., Jewett City, Conn. (C) 75.  
 Ashland Flax Mill Co., Ashland, Ohio (FD) 137.  
 Ashland Ktg. Co., Ashland, N. H. (K) 143.  
 Ashland Mfg. Co., Duckeyville, Md. (W & C) 108.  
 Ashley Knitting Mills, Ashley, Pa. (K) 233.  
 Ashley & Bailey Co., Paterson, N. J.; Fayetteville, N. C.; Coatsville, Columbia, Marietta and York, Pa. (S) 154, 188, 236, 240, 250.  
 Ashley & Shaw Silk Co., Hackettstown and Phillipsburg, N. J., and Avoca, Pa. (S) 151, 153, 233.  
 Ashtabula Worsted Mills, Ashtabula, O. (W) 197.  
 Ashton, James, Philadelphia, Pa. (W) 203.  
 Ashton Mills, Ashton, R. I. (C) 251.  
 Ashuelot Warp Co., Ashuelot, N. H. (C) 143.  
 Ashuelot Woolen Co., Ashuelot, N. H. (W) 143.  
 Ashwell, E. J. & Co., Jamestown, N. Y. (C) 170.  
 Ashworth, J. E. & Sons, Westbrookville, N. Y. (W) 184.  
 Ashworth, James T., Chicopee, Mass. (K) See Too Late for Classification List.  
 Ashworth & Guyer (Elmira Hosiery Mills) 191.  
 Asplnook Co., Jewett City, Conn. (Pr, D & Bl) 75. Also Too Late for Classification List.  
 Assabet Mills, Maynard, Mass. (W) 124.  
 Aston & West Branch Mills (Rhodes Bros.) 232.  
 Astoria Carpet Mills (Jos. Wild & Co.) 163.  
 Astoria Silk Works, Long Island City and Unionport, N. Y. (S) 171, 182.  
 Athens Cotton Mill Co., Athens, Ala. (C) 67.  
 Athens Knitting Co., Athens, N. Y. (K) 163.  
 Athens Mfg. Co., Athens, Ga. (C) 85.  
 Athens Woolen Mills, Athens, Tenn. (W) 268.  
 Atherton Mills, Charlotte, N. C. (C) 185.  
 Athletic Knitting Co., Utica, N. Y. (K) 181.  
 Atkins & Pearce Mfg. Co., The Cincinnati, Ohio (C) 197.  
 Atlanta Cotton Mills, Atlanta, Ga. (C) 85.  
 Atlanta Hosiery Mills, Atlanta, Ga. (K) 85.  
 Atlanta Knitting Mills, Atlanta, Ga. (K) 85.  
 Atlanta Woolen Mills, Atlanta, Ga. (W) 85.  
 Atlantic Cotton Mills, Lawrence, Mass. (C) 121.  
 Atlantic Ktg. Co., Cohoes, N. Y. (K) 166.  
 Atlantic Mfg. Co., Providence, R. I. (C & S) 257.  
 Atlantic Mills, Providence, R. I. (W) 257.  
 Atlantic & Gulf Mills, Quitman, Ga. (C) 91.  
 Atlas Knitting Co., Amsterdam, N. Y. (K) 161.  
 Atlas Knitting Mill (Owen Osborne) 223.  
 Atlas Linen Co., Meredith, N. H. (FD) 146.  
 Atlas Silk Co., New York, N. Y. (S) 173.  
 Atlas Swiss Embroidery Co., New York, N. Y. (S) 172.  
 Atlas Underwear Co., Piqua, Ohio (K) 200.  
 Attawaugan Co., Ballouville, Killingly and Montville, Conn. (C) 72, 76.  
 Attawaugan Mill (Attawaugan Co.) 76.  
 Attleboro Dye Works (R. Wolfenden & Sons) 111.  
 Atwood, M. J., Plymouth, Pa. (S) 244.  
 Auburn Blanket Co., Auburn, N. Y. (W) 163.  
 Auburn Knitting Mills, Auburn, Pa. (K) 233.  
 Auburn Woolen Co., The, Auburn, N. Y. (W) 163.  
 Audiger & Meyer Silk Co., Paterson, N. J. (S) 154.  
 Auesbach & Thompson, San Francisco, Cal. (S) 71.  
 Augenstein Bros. (Napoleon Woolen Mills) 200.  
 Auger & Simon Silk Dyeing Co., Paterson, N. J., and Allentown, Pa. (D & F) 154, 231.  
 Augusta Factory, The, Augusta, Ga. (C) 85.  
 Augusta Silk Works, Paterson, N. J. (S) 154.  
 Auredeen, John, Cincinnati, Ohio (K) 198.  
 Aurora Bleachery & Dye Works, Aurora, Ill. (Bl & D) 92.  
 Aurora Cotton Mills, Aurora, Ill. (C) 92.  
 Aurora Cotton Mills, Burlington, N. C. (C) 185.  
 Aurora Wool Scouring Mill, Aurora, Ill. (W) 93.  
 Austin, R. H., Westfield, Mass. (C) 123.  
 Australian-American Woolen Co., Seattle, Wash. (W) 278.  
 Auvergne Mills (David Armitage & Son) 235.  
 Avalon Knitting Co., Utica, N. Y. (K) 181.  
 Avalon Mills, Mayodan, N. C. (C) 192.  
 Aveyard, Wm. & Co., Doylestown, Pa. (W) 237.  
 Avoca Silk Co., Avoca, Pa. (S) 233.  
 Avon Mfg. Co., Lewiston, Me. (C) 103.  
 Avon Mills, Gastonia, N. C. (C) 189.  
 Avondale Mills Co., Birmingham, Ala. (C) 67.  
 Axford, John, Philadelphia, Pa. (K) 203.  
 Ayers, Wm. & Sons, Philadelphia, Pa. (W) 203.  
 Ayreshire Woolen Mills, Skaneateles Falls, N. Y. (W) 151.

- Eacharach & Loeb, Cincinnati, O. (K) 198.  
 Bachmann, Louis (Northboro Woolen Mills) 113.  
 Backus Bros., Atchison Kansas (FD) 99.  
 Bacon Bros., Winchester, Mass. (W) 134.  
 Baer, Eugene & Co., Lehighton, Pa. (S) 240.  
 Bagdad Rug Co., Paterson, N. J. (W) 154.  
 Bailey, C., Philadelphia, Pa. (J) 203.  
 Bailey, Chas. & Sons (The Bailey Ktg. Mills) 169.  
 Bailey, G. W., So. Williamsport, Pa. (K) 248.  
 Bailey, John T. & Co., Philadelphia, Pa. (J) 203.  
 Ealley Knitting Mills, The, Fort Plain, N. Y. (K) 169.  
 Bailey, Oscar L. & Co., Everett, Mass. (K) 116.  
 Baker, A. T. & Co., Philadelphia, Pa. (W) 203.  
 Baker Bros., Schuylkill Haven, Pa. (K) 246.  
 Baker, G. H. (Leicester Ktg. Mill) 261.  
 Baker, J. N., Evansville, W. Va. (W) 279.  
 Baker, Lucy R., Mrs., Nashua, N. H. (K) 146.  
 Baker & Schofield Co., Paterson, N. J. (S) 154.  
 Bakes, E., Philadelphia, Pa. (W) 203.  
 Bakhous & Kuenzel Co., The, New Bremen, O. (W) 200.  
**Bala Cotton Mills, Concord, N. C. (C) 187.**  
 Balas, Freres, Hoboken, N. J. (S) 151.  
 Baihian Bros. (Tiffin Woolen Mills) 200.  
 Balcolm Mill (A. Roberts & Co.) 143.  
 Baldwin Mfg. Co., Bank, Md. (W) 108.  
 Ball, H. C. & Co., Philadelphia, Pa. (W) 203.  
 Ball, Wm., Paterson, N. J. (S) 154.  
 Ballantyne, John & Sons, Philadelphia, Pa. (K) 203.  
 Ballard, J. O. & Co. (Malone Woolen Mills) 171.  
 Ballardville Mills, Ballardvale, Mass. (W) 111.  
 Ballou Mills of the Attawaugan Co., Ballouville, Conn. (C) 72.  
 Ballou Yarn Co., Providence, R. I. (C) 257.  
 Balthazar, E. & A. (Home Silk Mills) 170.  
 Baltic Carpet Mill (Wm. Carey) 209.  
 Baltic Cotton Mills Co., Baltic, Conn. (C) 72.  
 Baltic Mills Co., Enfield, N. H. (W) 143.  
 Baltimore Steam Quilt Works (M. H. Marcus & Bro.) 132.  
 Baltimore Waste Co. (K. Egan & Co.) 107.  
 Baltz Bros., agts., Philadelphia, Pa. (W) 203.  
 Bamberg Cotton Mills, Bamberg, S. C. (C) 262.  
 Bamford Bros. Silk Mfg. Co., Belvidere and Paterson, N. J., and Wilkesbarre, Pa. (S) 148, 154, 250.  
 Baneroft, Joseph & Sons Co., Wilmington, Del. (C, B1 & D) 84.  
 Bandman & Heuman, New York, N. Y. (S) 173.  
 Bandon Woolen Mills Co., Bandon, Ore. (W) 201.  
 Banfill Knitting Mills, Woonsocket, R. I. (K) 260.  
 Banfill, O. D. (Banfill Knitting Mills) 260.  
 Bank, A. M., New York, N. Y. (S) 173.  
 Banner Silk Co., Paterson, N. J. (S) 154.  
 Banner, Thomas, Estate of, Philadelphia, Pa. (C) 203.  
 Bannigan, A. (Banner Silk Co.) (S) 154.  
 Bannister, George, Philadelphia, Pa. (K) 203.  
 Bannockburn Cotton Mills, Middleton, Ga. (C) 90.  
 Baraboo Knitting Works (Estate of J. H. Welch) 250.  
 Baraboo Towel Mills (Geo. McArthur & Son) 250.  
 Barber, E. L., Bridgeport, Pa. (W) 234.  
 Barber, Geo., Philadelphia, Pa. (W) 203.  
 Barber, J. W. & Co., Philadelphia, Pa. (S) 203.  
 Barber, L., Mystic, Conn. (C) 77.  
 Barber, William, Lowell, Mass. (C) 122.  
 Barbour Flax Spinning Co., Paterson, N. J. (F1, J & D) 154.  
 Barclay Silk Co., Clifton, N. J. (S) 149.  
 Barker Cotton Mill Co., Mobile, Ala. (C) 69.  
 Barker Mill, Auburn, Me. (W) 102.  
 Barkley, Lemuel R., Bruceton Mills, W. Va. (W) 279.  
 Barlow, Noah, Philadelphia, Pa. (S) 203.  
 Barnaby Mfg. Co., Fall River, Mass. (C & S) 116.  
 Barnard, Belle F., Tottenville, N. Y. (S) 181.  
 Barnard, Geo. & Co., Brooklyn, N. Y. (K) 164.  
 Barnard Mfg. Co., Fall River, Mass. (C) 116.  
 Barnesville Hosiery Co., Barnesville, O. (K) 197.  
 Barnesville Mfg. Co., Barnesville, Ga. (C & D) 86. (Also See Too Late Classification List.)  
 Barnesville Mfg. Co., The, Barnesville, W. Va. (W) 279.  
 Barnett, Wm., Albany, N. Y. (W) 161.  
 Barnett, S. L. & Co., Hillsdale, N. J. (S) 151.  
 Barney, W. P. (Burnside Mill) 259.  
 Barnhardt Mfg. Co., Charlotte, N. C. (C) 185.  
 Baron, Straus & Co., Brooklyn, N. Y. (K) 164.  
 Baron & Housley (Hyrum Woolen Mills) 273.  
 Barr Mfg. Co., Philadelphia, Pa. (W) 203.  
 Barrall, Paul, Nanticoke, Pa. (K) 242.  
 Barrett, Nephews & Co., New York, N. Y. (D) 173.  
 Barrett, William, Philadelphia, Pa. (B1) 203.  
 Barretts, Palmer & Heal, Nordhoff, N. J. (D & F) 153.  
 Barron Woolen Mill Co., Barron, Wis. (W) 250.  
 Barrows, David & Son, Philadelphia, Pa. (K) 203.  
 Barrows, E. L., Rockville, Conn. (S) 79.  
 Barrows & Dounton, Philadelphia, Pa. (J) 203.  
 Bartlett, Edwin, North Oxford, Mass. (C) 123.  
 Bartlett, H. O., Harmony, Me. (W) 103.  
 Bartlett Woolen Mill (H. O. Bartlett) 103.  
 Barton, F. C., New York, N. Y. (C & S) 173.  
 Bartow & Cookson, Fitchburg, Mass. (C) 118.  
 Bartrug & Moore, Hundred, W. Va. (W) 279.  
 Basch & Greenfield Co., Newark, N. J. (W) 152.  
 Bast, J. P., Schuylkill Haven, Pa. (K) 246.  
 Bateman, Wm., Philadelphia, Pa. (W) 203.  
 Bates, C. & Co., Boston, Mass. (C) 112.  
 Bates Mfg. Co., Lewiston, Me. (C) 103.  
 Batesville Mill, Greenville, S. C. (C) 265.  
 Bath Knitting Mills (Odenwelder & Co.) 233..  
 Bath Silk Mfg. Co., Bath, Pa. (S) 233.  
 Battle, B. L., Mfg. Co., Warrenton, Ga. (K) 92.  
 Batty's, Job, Sons Co., Ltd., Philadelphia, Pa. (W) 203.  
 Bauer & Black, Chicago, Ill. (C) 93.  
 Baum, C. P. Co., Chicago, Ill. (S & K) 93.  
 Bausher, S. D., Hamburg, Pa. (K) 238.  
 Bay City Ktg. Co., Bay City, Mich. (K) 135.  
 Bay State Cordage Co., Newburyport, Mass. (J) 126.  
 Bay State Mills, Lowell, Mass. (W) 122.  
 Bay State Worsted Co., Worcester, Mass. (W) 134.  
 Beacon Mfg. Co., New Bedford, Mass. (C) 126.  
 Beardwood, Thos. & Bro., Philadelphia, Pa. (D) 203.  
 Beargrass Woolen Mills, Louisville, Ky. (W) 100.  
 Beatrice Rug Factory, Beatrice, Neb. (W) 142.  
 Beattie Fg. Co., Little Falls, N. J. (W) 152.  
 Beatty Felting Co., Mishawaka, Ind. (W) 97.  
 Beatty, Robt. & Co., Philadelphia, Pa. (C) 203.  
 Beau Ideal Knitting Mills, Mohn's Store, Pa. (K) 241.  
 Beaumont, Benjamin, Wrentham, Mass. (W) 135.  
 Beaumont Bros., East Foxboro, Mass. (W) 115.  
 Beaumont Mfg. Co., Spartanburg, S. C. (C) 267.  
 Beaver Brook Mills, Collinsville, Mass. (W) 114.  
 Beaver, D. F. (Waynesboro Hosiery Mill) 249.  
 Beaver Dam Cotton Mills, Beaver Dam, Wis. (C) 280.  
 Beaver Dam Woolen Mfg. Co., Beaver Dam, Wis. (W) 280.  
 Beaver Dam Woolen Mills, Beaver Dam, Wis. (W) 280.  
 Beaver Knitting Mills, Hudson, N. Y. (K) 170.  
 Beaver Mill, North Adams, Mass. (C) 127.  
 Beaver Velvet Co., Paterson, N. J. (S) 154.  
 Beaver Woolen Mfg. & Milling Co., Beaver, Utah (W) 272.  
 Bechmann, Geo. F. & Son, Philadelphia, Pa. (C, W & S) 202.  
 Bechtold, Albert, Philadelphia, Pa. (Pr) 203.  
 Beck Bros., Hoboken, N. J. (S) 151.  
 Beck, Geo. E., Bixler, Pa. (W) 233.  
 Beck Hosiery Co., Cressona, Pa. (K) 236.  
 Beck, Wm. & Chas., Lawrence, Mass. (C) 121.  
 Becker, Chas. W., Amsterdam, N. Y. (W & D) 161.  
 Becket Silk Co., Becket, Mass. (S) 111.  
 Beckett, David, Silk Co., Paterson, N. J. (S) 154.  
 Beckman Co., The, Cleveland, O. (W) 188.  
 Bedford Mills Co., Bedford City, Va. (W) 276.

- Beebe, Chas. G., Mrs., Norwich, Conn. (C) 78.  
 Beebe, L. & Co. (Hopewell Mills) 131.  
 Beebe, Webber & Co., Holyoke and Spencer, Mass. (W) 120, 131.  
 Beechdale Mills (Briggs Mfg. Co.) 81.  
 Behal, Joseph L. (Standard Ktg. Mills) 227.  
 Behler, S. R., Newton, Kansas (W & J) 100.  
 Behrman, J. M., Chicago, Ill. (K) 93.  
 Belcher, Harry, Philadelphia, Pa. (C) 203.  
 Belding Bros. & Co., Rockville, Conn., Northampton, Mass., and Belding, Mich. (S) 79, 127, 135.  
 Belfast Mesh Underwear Co., Torrington, Conn. (K) See Too Late for Classification List.  
 Belgrade Carpet Mills (McDowell Bros.) 221.  
 Belknap, C. F., Philadelphia, Pa. (S) 263.  
 Belmont Cotton Mills (L. Banks Holt) 189.  
 Belleville Woolen Mill, Allenton, R. I. (W) 251.  
 Bellevue Worsted Mills (Benj. W. Greer) 216.  
 Belmont Silk Mills, Hawley, Pa. (S) 238.  
 Bell's, Henry H., Sons Co., Milton, N. Y. (K) 172.  
 Bellvue Cotton Mills, Newport, Tenn. (C) 270.  
 Belmont Carpet & Art Square Mills (John Kuestner) 220.  
 Belmont Cotton Mills, Shelby, N. C. (C) 195.  
 Belton Cotton Mills, Belton, Texas (C) 271.  
 Belton Mills, Belton, S. C. (C) 262.  
 Belvidere Woolen Mfg. Co., Lowell, Mass. (W) 122.  
 Bemis Bros. Bag Co., Omaha, Neb. (W & C) 142.  
 Bemis Mills, Bemis, Mass. (W) 111.  
 Benbow, D. W. C. (Hamburg Cotton Mills) 193.  
 Bender, Val., Tub, Pa. (W) See Too Late for Classification List.  
 Benner, F. J., Rockford, Minn. (W) 140.  
 Bennett, Adolph, New York, N. Y. (S) 173.  
 Bennett Spg. Co., New Bedford, Mass. (C) 126.  
 Bennett, Wm., Philadelphia, Pa. (K) 205.  
 Bennett & Crowley (Norfolk Woolen Mills) (W) 178.  
 Bennettsville Mfg. Co., Bennettsville, S. C. (C) 262.  
 Bennington Knitting Co., Bennington, Vt. (K) 273.  
 Bentley Bros., Paterson, N. J. (S) 154.  
 Bentley Bros., Shelton, Conn. (W) 79.  
 Bentley & Gerwig, Ltd., New Brighton, Pa. (FD) 242.  
 Beoll Mills, Fitchburg, Mass. (W) 118.  
 Berger, H. & Sons, Schuylkill Haven, Pa. (K) 246.  
 Berges, J. & Co., Philadelphia, Pa. (D) 205.  
 Bergey, M. B. & Co., Coopersburg and Souder-ton, Pa. (K) 236, 247.  
 Berglund, C. C., Brooklyn, N. Y. (S) 164.  
 Berkeley Co., Berkeley, R. I. (C) 251.  
 Berkeley Woolen Mills, Wales, Mass. (W) 132.  
 Berkeley Knitting Mills, The, Berkeley, Va. (K) 276.  
 Berkshire Cotton Mfg. Co., Adams, Mass. (C) 109.  
 Berkshire Mfg. Co., Ltd., Philadelphia, Pa. (C) 205.  
 Berlin Knitting Co., Bangor, Me. (K) 192.  
 Berlin & Trosky, New York, N. Y. (S) 173.  
 Bernhard, Morris, Buffalo, N. Y. (S) 165.  
 Bernon Mill (David N. Taft) 128.  
 Bernon Mills, Georgiaville, R. I. (C) 254.  
 Bernstein, Kaufmann & Co., Philadelphia, Pa. (S) 205.  
 Bernstein, Mitchell B., New York, N. Y. (S) 173.  
 Bernstein & Co., New York, N. Y. (S) 173.  
 Berry, H. T., Dulinsville, Va. (W) 276.  
 Bertnick, R., Joliet, Ill. (W) 96.  
 Bessemer City Cotton Mills, Bessemer City, N. C. (C) 184.  
 Bessie Minge Mfg. Co., Demopolis, Ala. (C) 67.  
 Bestoval Mill, Dubuque, Iowa (FD) 99.  
 Beswick, Samuel, Philadelphia, Pa. (W) 205.  
 Bethel Silk Co., Bethel, Conn. (S) 72.  
 Bethlehem Silk Co., The, Bethlehem, Pa. (S) 233.  
 Beth Mont Knitting Mills, Atlanta, Ga. (K) 85.  
 Beutel, Fred (Standard Knitting Mill) 165.  
 Beverly Hosiery Mills (Turner Birkhead) 148.  
 Beverwyck & McConihe Mills (Faith Knitting Co.) 163.  
 Bibb Mfg. Co., Columbus and Macon, Ga. (C) (Porterdale Mills & Taylor Mfg. Co.) 86, 90, 88, 91.  
 Bicyele Hosiery Co., Manchester, N. H. (K) 146.  
 Bigelow Carpet Co., Clinton and Lowell, Mass. (W) 114, 123.  
 Bilger, G., Denver, Colo. (W) 72.  
 Bilger, Nicholas, Philadelphia, Pa. (C) 205.  
 Billmyre, J. C., Martin, W. Va. (W) 279.  
 Blinder & Ellis, Philadelphia, Pa. (C & S) 205.  
 Binghamton Felting Co., Binghamton, N. Y. (W) 163.  
 Bings, John, Philadelphia, Pa. (W) 205.  
 Binns Patent Band Co., Philadelphia, Pa. (S) 205.  
 Binz, A. W. & B. (Conrad Binz Carpet Works) 205.  
 Binz, Conrad, Carpet Works, Philadelphia, Pa. (W) 205.  
 Binz, F., Philadelphia, Pa. (W) 205.  
 Bird, Theo., Bethlehem, Conn. (W) 205.  
 Birdgreenway, J. M., Paterson, N. J. (S) 154.  
 Birdsall Bros., Honesdale, Pa. (W) 239.  
 Birge, N. L. & Son's Co., Bristol, Conn. (K) 73.  
 Birkhead, Turner, Beverly, N. J. (K) 148.  
 Birkin, T. I. & Co., Chester, Pa. (C) 235.  
 Birmingham Cotton Mfg. Co., Birmingham, Ala. (C) 67.  
 Birmingham Hosiery Mills, Birmingham, Ala. (K) 67.  
 Bishop, Robt., Boston, Mass. (C & D) 112.  
 Biswanger, E., Estate of, Philadelphia, Pa. (W) 205.  
 Bitzer, Chas., Philadelphia, Pa. (K) 205.  
 Bitzer Hosiery Mfg. Co., Smyrna, Del. (K) 54.  
 Ejorkland, Erick, Cambridge, Minn. (W) 139.  
 Black Diamond Hosiery Mill, Reading, Pa. (K) 244.  
 Black Diamond Knitting Mills Co., Nanticoke, Pa. (K) 242.  
 Black Diamond Mill (Keen & Kniley) 240.  
 Black, Foster & Co. (Chesapeake Knitting Mills and Elizabeth Knitting Mills) 275.  
 Black, Jos. & Sons, Co., York, Pa. (K) 250.  
 Black, M., Mrs., Sandy Point, Me. (K) 106.  
 Black River Woolen Co., Ludlow, Vt. (W) 275.  
 Blackford, W. H. (Paris Woolen Mill) 142.  
 Blacksbury Spinning & Knitting Co., Blacksbury, S. C. (C) 262.  
 Blackstone Braid Co., Pawtucket, R. I. (C) 255.  
 Blackstone Mfg. Co., Blackstone, Mass. (C) 111.  
 Blackstone Stocking Co., Pawtucket, R. I. (K) 255.  
 Blair, S. H., New York, N. Y. (S) 173.  
 Blake & Co., Racine, Wis., and Peru, Ind. (W) 98, 282.  
 Blakely, Jno. & Son, Philadelphia, Pa. (C & W) 205.  
 Blanch Hosiery Mills Co., Chapel Hill, N. C. (K) 185.  
 Blanding, C. L., Mfg. Co., Providence, R. I. (W) 257.  
 Blankenburg, Rudolph Co., Philadelphia, Pa. (C) 205.  
 Blashek, R., La Crosse, Wis. (W) 281.  
 Bleakie, Robt. & Co., Hyde Park, Mass. (W) 121.  
 Blikle, Fred'k, Philadelphia, Pa. (K) 205.  
 Blickle's, Jno., Sons, Philadelphia, Pa. (K) 205.  
 Bliss, Valentine, Dickson, East Stroudsburg and Scranton, Pa., 236, 237, 246.  
 Block Bros. Knitting Co., San Francisco, Cal. (K) 71.  
 Block & Rheinheimer (United States Knitting Mills) 228.  
 Blodgett & Orswell Co., Pawtucket, R. I. (C) 255.  
 Blood, J. & Bro., Philadelphia, Pa. (K) 205.  
 Blood, John & Co., Philadelphia, Pa. (K) 205.  
 Blood Knitting Co., Amsterdam, N. Y. (K) 161.  
 Bloomsburg Silk Mill, Bloomsburg, Pa. (K & S) 233.  
 Blue, J. J. (Ettrick Woolen Mills) 281.  
 Blue Ridge Cotton Mill, Petersburg, Va. (C) 277.

- Blue Ridge Hosiery Mill Co., Landrum, S. C. (K) 266
- Blue Ridge Knitting Co., Hagerstown, Md. (K) 108.
- Blue Spring Mills, Oxford, Ala. (C) 69.
- Blum, Nicholas, New York, N. Y. (D) 174.
- Blumenthal, Sidney & Co., Shelton, Conn. (S) 79.
- Blythe, T. Ashby (Ashby Cotton Mills) 266.
- Boas Thread Co., Stamford, Conn. (C & S) 80.
- Bohst, W. J., Reading, Pa. (K) 244.
- Bochlowitz, H. (Riverside Knitting Mill) 167.
- Bochman, F. A. & Co., Philadelphia, Pa. (W) 205.
- Bock, E. C., Ann Arbor, Mich. (K) 135.
- Boehme & Rauch Cordage Co., Monroe, Mich. (J) 138.
- Bochn & Brauch, Paterson, N. J. (S) 154.
- Boesen, Wm. J., New York, N. Y. (S) 174.
- Boettger Piece Dye Works, Lodi, N. J. (Bl, D & F) 152.
- Boettger & Hinze, New York, N. Y. (F) 174.
- Boggs, Jno., Philadelphia, Pa. (W) 205.
- Boggs, Thomas & Sons, Philadelphia, Pa. (W) 205.
- Bollman, Geo. & Co., Adamstown, Pa. (W) 231.
- Bolton Bros. Silk Dyeing Co., Paterson, N. J. (D) 154.
- Bolton Mfg. Co., Fall River, Mass. (C) 116.
- Boltz, W. K., Pottsville, Pa. (K) 244.
- Bondsville Bl. & Dye Works, Bondsville, Mass. (Bl & D) 112.
- Bonham Cotton Mills, Bonham, Tex. (C) 271.
- Bonitz, Herman, Co., Lodi, N. J. (W) 152.
- Bonnie Cotton Mills, King's Mountain, N. C. (C) 191.
- Bonsack Bros., Bonsacks, Va. (W) 276.
- Bonte Cordage Co., Ltd., Hanover, Pa. (Fl) 238.
- Booth, W. J., Brooklyn, N. Y. (S) 164.
- Booth & Bro., Gladwyne, Pa. (W) 238.
- Boort Cotton Mills, Lowell, Mass. (C) 123.
- Borden Mfg. Co., Goldsboro, N. C. (C) 189.
- Borden Mfg. Co., Richard, Fall River, Mass. (C) 116.
- Border City Mfg. Co., Fall River, Mass. (C) 116.
- Borich Mills (Jacob Miller Sons & Co.) 222.
- Bornemann, B. & Son, St. Peter, Minn. (K & W) 140.
- Boscawen Mills, Penacook, N. H. (C) 147.
- Boston Braid Mfg. Co., Boston, Mass. (S) 112.
- Boston Button Co., Boston, Mass. (C) 112.
- Boston Duck Co., Bondsville, Mass. (C) 112.
- Boston Finishing Works, Williamstown, Mass. (Bl, D & F) 134.
- Boston Gore & Web Co., Chelsea, Mass. (C) 114.
- Boston, John (Keystone Fast Black Dye Works) 219.
- Boston Mfg. Co., Waltham, Mass. (C) 132.
- Boston Silk Co., Boston, Mass. (S) 112.
- Boston Silk Winding Co., Boston, Mass. (S) 112.
- Boston Thread & Twine Co., Boston, Mass. (Fl & C) 112.
- Boston Woven Hose & Rubber Co., Cambridgeport, Mass. (C) 112.
- Botany Worsted Mills, Passaic, N. J. (W) 153.
- Bottomly Mill (A. W. Darling) 114.
- Boudinot, H. R., Davenport, Iowa (F) 98.
- Bound Brook Woolen Mills, Bound Brook, N. J. (W) 148.
- Pourne Mills, Fall River, Mass. (C) 116.
- Bowden, Anthony, Cedar Grove, N. J. (C) 119.
- Bowden Felting Mills Co., Millbury, Mass. (W) 125.
- Bown, Jewell & Co., Jewell's, Ga. (C) 89.
- Bowen, W. J. (Nashua Woolen Mills) 99.
- Bower, W. H., Philadelphia, Pa. (D) 205.
- Bower & Kaufmann, Philadelphia, Pa. (K) 205.
- Bowers, Jas. Sons, Ltd., Chester, Pa. (W) 235.
- Bowling Green Knitting Mills, Bowling Green, S. C. (K) 262.
- Bowman, D. F., New Albany, Ind. (C) 97.
- Bowman, D. J., New York, N. Y. (K) 174.
- Boyd & Jones (Juniate Knitting Mill) 237.
- Boyd & Mangham, Griffin, Ga. (C) 85.
- Boyer, B. F., Co., Camden, N. J. (W) 148.
- Boyer, Thos. A., Reading, Pa. (W) 244.
- Boyle, A. & Bro., Philadelphia, Pa. (K) 205.
- Bradbury Bros., Philadelphia, Pa. (C & W) 205.
- Bradbury, J. H. & Co., Lyme, Conn. (W) See Too Late for Classification List.
- Bradford Hat Factory, Bradford, Mass. (W) 113.
- Bradford, H. E. & Co., Bennington, Vt. (K) 273.
- Bradford Mills, Philadelphia, Pa. (W) 205.
- Bradford Yarn Mills, Warren, Mass. (W) 132.
- Bradley Cordage Co., Dayton, Ohio (J) 149.
- Bradshaw Mfg. Co., Lowell, Mass. (C) 123.
- Brainerd & Armstrong Co., The, New London, Conn. (S) 77.
- Bramwell, Sam'l, Philadelphia, Pa. (K) 205.
- Brandes, Julius, Mfg. Co., Paterson, N. J. (S) 154.
- Brandon Mills, Greenville, S. C. (C) 265.
- Brandt, Joseph & Bro., New York, N. Y. (S) 174.
- Brandywine Dye Works, Wilmington, Del. (D) 84.
- Brattleboro Hosiery Co., Brattleboro, Vt. (K) 275.
- Braun, Mrs. H. I., Philadelphia, Pa. (K) 205.
- Braunstein, Samuel, New York, N. Y. (S) 174.
- Brautigan, Robt., Brooklyn, N. Y. (C) 164.
- Bray, T. A., Pay Down, Mo. (W) 112.
- Brayshaw, James, North Weymouth, Mass. (C) 128.
- Bready, E. K., Philadelphia, Pa. (W) 205.
- Brehm & Stehle, Philadelphia, Pa. (D) 205.
- Brenham Cotton Mill, Brenham, Tex. (C) 271.
- Brewin, Harry (Peerless Silk Dye Works) 222.
- Brickner Woolen Mills Co., Sheboygan Falls, Wis. (W) 282.
- Bridgeport Coach Lace Co., Bridgeport, Conn. (W & S) 73.
- Bridgeport Silk Co., Bridgeport, Conn. (S) 73.
- Bridgeton Woolen Co., Bridgeton, N. J. (W) 148.
- Bridgewater Mfg. Co., Bridgewater, Va. (W) 276.
- Brlent Bros., Englewood, Tenn. (C) 263.
- Briggs, H. A. & Co., Pawtucket, R. I. (C) 255.
- Briggs Mfg. Co., The, Voluntown, Conn., and Rockville, R. I. (C) 81, 259.
- Briggs & Mendenhall, Pennville, Ind. (W) 98.
- Brigham City Woolen Mills Co., Brigham, Utah (W & K) 272.
- Brighton Mills (A. Radley) 221.
- Brighton Mills, Passaic, N. J. (C) 153.
- Brighton Mills, Philadelphia, Pa. (W) 205.
- Brightwood Mfg. Co., North Andover, Mass. (W, D & F) 127.
- Brill Bros., Brooklyn, N. Y. (K) 164.
- Brill, S. & Bro. (Globe Cloth Examining, Sponging & Refinishing Works) 174.
- Brilliant Silk Co., Paterson, N. J. (S) 154.
- Brimmer Bros. & Co., Richland Centre, Wis. (W & K) 282.
- Bristol Carpet Mills (Thos. L. Leedom & Co.) 234.
- Bristol Cotton Mills, Bristol, Tenn. (C) 269.
- Bristol Hosiery Mills, Bristol, Pa. (K) 234.
- Bristol Knitting Co., Bristol, Pa. (K) 234.
- Bristol Mfg. Co., Bristol and Plainville, Conn. (K) 73, 78.
- Bristol Mfg. Co., New Bedford, Mass. (C) 126.
- Bristol Worsted Mills (W. H. Grundy & Co.) 234.
- Bristow, McCollum & Post, Paterson, N. J. (S) 154.
- British Hosiery Co., Olneyville, R. I. (K) 255.
- Broad Brook Co., Broad Brook, Conn. (W) 73.
- Broadalbin Ktg. Co., Ltd., Broadalbin, N. Y. (K) 162.
- Broadbent, Ammon, Est. of, Mercer, Pa. (W) 241.
- Broadbent, J. & Son, Unionville, Conn. (C & W) 81.
- Broadhead, Wm. & Sons (Broadhead Worsted Mills) (Meadowbrook Mills) 169, 170.
- Broadhead Worsted Mills, Jamestown, N. Y. (W) 170.
- Broadus Cotton Mills, Stevenson, Ala. (C) 70. (Also See Too Late for Classification List.)
- Brockway, Geo. E. (Marble Ktg. Mills) 179.
- Broemel, A., Bucyrus, Ohio (W) 197.
- Brown Cotton Mills, Anderson, S. C. (C) See Too Late for Classification List.

- Bromley Bros.' Carpet Co., Philadelphia, Pa. (W) 205.
- Bromley, Jas. & Geo. D., Philadelphia, Pa. (W) 205.
- Bromley, John & Sons, Philadelphia, Pa. (W) 205.
- Bromley Mfg. Co., Philadelphia, Pa. (C) 207.
- Bronx Co., New York, N. Y. (Pr & B) 174.
- Brookdale Bleachery, Hoboken, N. J. (B) 151.
- Brooke, M. E., Philadelphia, Pa. (C) 207.
- Brookland Mills, Winchester, Va. (W) 278.
- Brooklyn Ktg. Co., Brooklyn, N. Y. (K) 164.
- Brooklyn Silk Mills, Brooklyn, N. Y. (S) 164.
- Brooklyn Silk Dye Works, Brooklyn, N. Y. (D) 164.
- Brooklyn Woolen Mills (J. B. Eastwood & Co.) 240.
- Brooks, Geo. & Son, Philadelphia, Pa. (S) 207.
- Brooks, John F., Co., Highlandville, Mass. (K) 120.
- Brooks Mfg. Co., Greer Depot, S. C. (C) 265.
- Brooks Mfg. Co., Herkimer, N. Y. (K) 170.
- Brookside Mill (C. F. Scholfield) 76.
- Brookside Mills, Knoxville, Tenn. (C) 270.
- Brookside Mills (Wm. Carson & Co.) 240.
- Brookside Worsted Mills, Philadelphia, Pa. (W) 207.
- Brookville Woolen Mills, Brookville, Pa. (W) 234.
- Broom, Harry (Flower City Dye Works) 180.
- Brophy's T. Sons, Philadelphia, Pa. (D) 207.
- Brower & Love Bros. (Indiana Warp Mills) 97.
- Brown-Aberle Co., The, Philadelphia, Pa. (K) 207.
- Brown Bros., Shiloh, W. Va. (W) 280.
- Brown, C. M. & Co., Philadelphia, Pa. (W) 207.
- Brown County Woolen Mills, New Ulm, Minn. (W & K) 140.
- Brown, E. W. (Waynesville Woolen Mills) 196.
- Brown, G. T., Schoohoh, Ky. (W) 101.
- Brown Hosiery Co., Lowell, Mass. (K) 123.
- Brown, H. H. & Sons, Paterson, N. J. (D) 154.
- Brown, John, Milan, O. (K) 199.
- Brown Knitting Co., Philadelphia, Pa. (K) 207.
- Brown, L. D. & Son Co., The, Middletown, Conn. (S) 76.
- Brown Mills, Dover, Me. (W) 103.
- Brown, R. H. & Son, Monmouth, Va. (W) 277.
- Brown, Thomas E. & Son, Philadelphia, Pa. (K) 207.
- Brown, Wm. E., Providence, R. I. (K) 257.
- Brown, Wm. W., Worcester, Mass. (C) 134.
- Brown & Hunt, Philadelphia, Pa. (K) 207.
- Brown & Whittier, Lawrence, Mass. (W) 121.
- Brown's, Geo., Sons, Mount Joy, Pa. (W) 242.
- Browne, Randall (Mystic Twine Co.) 77.
- Brownell & Co., Moodus, Conn. (C) 76.
- Brownsville Woolen Mill Co., Brownsville, Ore. (W) 201.
- Bruey, Frank G., Philadelphia, Pa. (C & W) 207.
- Brumbach, A. J., Reading, Pa. (W) 244.
- Brumbach Bros., Reading, Pa. (W) 244.
- Bruner, Francis A., Philadelphia, Pa. (S) 207.
- Brunger, S. & Co., Sullivan, Ind. (W) 98.
- Brunner & Driefuss, New York, N. Y. (S) 174.
- Buck, Thos. & Co., Philadelphia, Pa. (K) 207.
- Buckhalter, Fred, Philadelphia, Pa. (D & K) 207.
- Buckhannon Woolen Mills, Buckhannon, W. Va. (W) 279.
- Buell Mfg. Co., St. Joseph, Mo. (W) 142.
- Buell Mills (Carter & Morrison) 147.
- Buena Vista Woolen Mills, Buena Vista, Va. (W) 274.
- Buffalo Batting Mill, Buffalo, N. Y. (C) 166.
- Buffalo Cotton Mills, Union, S. C. (C) 267.
- Buffalo Fringe Works (Morris Bernhard) 166.
- Buffalo Mfg. Co., Stubbs, N. C. (C) 195.
- Buffalo Silk Mfg. Co., Paterson, N. J. (S) 154.
- Buffalo Weaving Co., Buffalo, N. Y. (C) 166.
- Buffalo Woolen Mills (Peter Graff & Co.) 250.
- Buffalo Woven Label Works, Buffalo, N. Y. (S) 166.
- Buffums' Mills, Oxford, Mass. (W) 128.
- Buhl, A. K., (Empire State Woven Label Co.) 184.
- Bunting, Saml. B., Phila., Pa. (W) 209.
- Burleson, A. B. & Co., Jewett City, Conn (C) 75.
- Burlington Blanket Co., Burlington, Wis. (W) 280.
- Burlington Cotton Mills, Burlington, Vt. (C) 275.
- Burlington Hosiery Mills, Burlington, N. C. (K) 185.
- Burlington Mills, Winooski, Vt. (W) 276.
- Burlington Silk Co., Paterson, N. J. (S) 154.
- Burnett Knitting Co., The, Owosso, Mich. (K) 138.
- Burnham, L. A. & Co. Gloucester, Mass. (C) 119.
- Burns, John, Ardmore, Pa. (C) 233.
- Burns, P. V., Janesville, Wis. (C) 281.
- Burns, Wm. H., Philadelphia, Pa. (D) 209.
- Burnside Mill, Shannock, R. I. (W) 259.
- Burroughs & Taylor Co., Cave, Tenn. (W) 269.
- Burson Ktg. Co., Rockford, Ill. (K) 96.
- Burton, Andrew, Phila., Pa. (D) 209.
- Burton Co., The, Chicago, Ill. (C) 93.
- Burton, J. G. (Farmville Hosiery Co.), 276.
- Burton Mills, Shelby, N. C. (C) 195.
- Burtworth Carpet Co., Chicopee, Mass. (W) 114.
- Buschmann, C. H., New York, N. Y. (S) 174.
- Busiel, H. M., East Andover, N. H. (K) 143.
- Busiel, J. W. & Co., Laconia, N. H. (K) 145.
- Butcher, F. & Son, East Randolph, N. Y. (W) 168.
- Butler Mills, New Bedford, Mass. (C). See Too Late for Classification List.
- Butler Silk Mill Co., Butler, Pa. (S) 234.
- Butler Worsted Mill, Lawrence, Mass. (W) 122.
- Butterworth, Geo., Phila., Pa. (C W & S) 209.
- Buttonwood Shoddy Mill, Wilkinstonville, Mass. (W) 134.
- Buttorff & Kline, New Cumberland, Pa. (W) 242.
- Butz, Siegfried, Paterson, N. J. (S) 154.
- Byfield Woolen Co., Byfield, Mass. (W) 113.
- Byram, F. A. (Germantown Lace Works), 216.
- Byram Mfg. Co., Chester, Pa. (W) 235.
- Byrne, Thos. F., Phoenixville, Pa. (K) 243.
- Cabarrus Cotton Mill, Concord, N. C. (C) 187.
- Cable Flax Mills, Schaghticoke, N. Y. (F) 180.
- Cabot Mfg. Co., Brunswick, Me. (C) 102.
- Cabot Woolen Mill (I. F. Haines) 275.
- Cache Knitting Works, Logan, Utah (K) 273.
- Calder, W. D., South Westerlo, N. Y. (W) 181.
- Caledonia Carpet Mill, Philadelphia, Pa. (W) 209.
- Caledonia Mills (Caledonia Mills Co.) 235.
- Caledonia Mills Co., Clifton Heights, Pa. (W) 235.
- Caledonia Worsted Mill, Philadelphia, Pa. (W) 209.
- California Cotton Mills Co., Oakland, Cal. (C & J) 71.
- California Flax Mill, Oakland, Cal. (F) 71.
- California Jute Mill Co., San Francisco, Cal. (J) 71.
- California Woolen Mill, California, Mo. (W) 141.
- Call Mfg. Co., Elmira, N. Y. (C) 168.
- Callaghan, Albert, Trustee, Phila., Pa. (W) 269.
- Callahan, Cornelius, Canton Junction, Mass. (C) 113.
- Callahan, Cornelius, Co., The, Inc., Boston, Mass. (K) 112.
- Calumet Woolen Co. (Calumet & Hecla Mills) 132.
- Calumet & Hecla Mills, Uxbridge, Mass. (W) 132.
- Cambria Silk Throwing Mill, Danmore, Pa. (S) 237.
- Cambridge Woolen Mills (Erick Bjorkland) 139.
- Camden Cotton Mill, Camden, S. C. (C) 262.
- Camden Curtain & Embroidery Co., Camden, N. J. (C) 148.
- Camden Dye Works (Joseph Husson) 149.
- Camden Knitting Co., Camden, N. Y. (K) 165.
- Camden Woolen Co., Camden, Me. (W) 102.
- Camden Woolen Mill, Camden, Ark. (W) 70.
- Cameron, A. J. & Co., Phila., Pa. (W) 209.
- Cameron, A. J. & Co. (Aluncie Underwear Co.) 97.
- Cameron Cotton Mill Co., Cameron, N. C. (C) 185.
- Cameron Worsted Co., The A. J., Phila., Pa. (W) 209.
- Cameron & Krug, Paterson, N. J. (Pr) 154.
- Campbell, Jas., Centredale, R. I. (W) 253.
- Campbell, J. A. & Bro., Phila., Pa. (W) 209.

- Campbell, John J., Philadelphia, Pa. (F) 209.  
 Campbell, J. P., Est. (Campbell Mills) 257.  
 Campbell Mfg. Co., Sangerville, Me. (W) 106.  
 Campbell, M. F. & Co. (No. Andover Silk Wiping Cloth Co.) 127.  
 Campbell Mills, Potter Hill, R. I. (W) 257.  
 Campbell & Mashburn, Bollivar, Tenn. (W) 268.  
 Canadian Knitting Mills (Spier, S.) 165.  
 Canasawacta Knitting Co., Sherburne, N. Y. (K) 181.  
 Candor Blanket Co., Candor, N. Y. (W) 166.  
 Canfield Mfg. Co., Ltd., Phila., Pa. (C) 209.  
 Canfield Rubber Co., The, Bridgeport, Conn. (K) 73.  
 Cannon Mfg. Co., Concord, N. C. (C) 187.  
 Cannon, H. & A. R. Northrup (Foot Knitting Co.) 174.  
 Canoe River Mills, Taunton, Mass. (C) 131.  
 Canochet Mills, Canochet, R. I. (C) 253.  
 Canton Cotton Mills, Canton, Ga. (C) 86.  
 Canton Wool Mills (Jno. E. Rockwell) 234.  
 Capelsie Cotton Mills, Troy, N. C. (C) 196.  
 Capital City Mills, Columbia, S. C. (C) 263.  
 Capital City Woolen Mills, Des Moines, Iowa (W) 99.  
 Capital Ktg. Mills (S. E. Clifton & Co.) 167.  
 Capps Cotton Mill, The, Toccoa, Ga. (C) 91.  
 Capps, J. & Sons, Ltd., Jacksonville, Ill. (W) 95.  
 Capron Knitting Co., Ufca, N. Y. (K) 182.  
 Capron Satinet Mill, Uxbridge, Mass. (W) 132.  
 Capstick, John & Son, Montville, N. J. (Pr, D & F) 152.  
 Capucine Co., The, Lowell, Mass. (D & F) 123.  
 Caraleigh Mills Co., Raleigh, N. C. (C) 193.  
 Cardinal Silk Co., Paterson, N. J. (S) 151.  
 Cardinal & Becker, Paterson, N. J. (S) 154.  
 Cardington Hosiery Mill, Cardington, Pa. (K) 234.  
 Cardington Mills (Wolfenden, Shore & Co., Ltd.) 234.  
 Carey, Wm., Philadelphia, Pa. (W) 209.  
 Caribou Woolen Mill, Caribou, Maine (W) 103.  
 Carleton Mills Co., Sangerville, Me. (W) 106.  
 Carlisle Carpet Factory (Stephens & Beestem) 234.  
 Carlisle Silk Mill, Carlisle, Pa. (S) 234.  
 Carlson Currier Co., Petaluma, Cal. (S) 71.  
 Carlton, E. G. & Sons, Rochdale, Mass. (W) 129.  
 Carmany, C. P. (Wissahickon Dye Wks.) 149.  
 Carolina Cotton Mills, Burlington, N. C. (C) 185.  
 Carolina Mills, The, Greenville, S. C. (C) 265.  
 Carolina Mills Co., Carolina, R. I. (W) 253.  
 Carpenter, D. J. (Newton Hosiery Mills) 193.  
 Carpenter, Ed. H. (Castine Line & Twine Co.) 103.  
 Carpenter Hosiery Co., Louisville, O. (K) 199.  
 Carpenter, N. L. & Son, Natchez, Miss. (C) 141.  
 Carpenter, Wm. D., So. Berwick, Me. (W) 107.  
 Carrie Knitting Mill, Hellertown, Pa. (K) 239.  
 Carroll Mfg. Co., Cohoes, N. Y. (C) 166.  
 Carrollton Woolen Mills, Carrollton, Ky. (W) 100.  
 Carrollton Woolen Mills (Mrs. Wm. McIntyre) 141.  
 Carruth, John G. & Co., Phila., Pa. (W) 209.  
 Carson, Geo., Philadelphia, Pa. (W) 209.  
 Carson, John W., Philadelphia, Pa. (D) 209.  
 Carson, Robt., Philadelphia, Pa. (W) 209.  
 Carson, Wm. & Co., Lenni Mills, Pa. (W) 240.  
 Carter, J. D., Winchester, Ind. (W) 98.  
 Carter, Wm. & Co., Highlandville, Mass. (K) 120.  
 Carter & Morrison, Tilton, N. H. (W) 147.  
 Carter & Rogers, Lebanon, N. H. (W) 146.  
 Carthage Woolen Mill Co., Carthage, Mo. (W) 141.  
 Caryville Mills (Taft, Murdoch & Co.) 113.  
 Cascade Mills (G. H. McDonald & Co.) 167.  
 Cascade Woolen Mill, Oakland, Maine (W) 105.  
 Case Mfg. Co., Ltd., Philadelphia, Pa. (S) 209.  
 Caspers Silk Co., Paterson, N. J. and Deposit, N. Y. (S) 154. (Also Too Late Classification List.)  
 Castine Line & Twine Co., Castine, Me. (C) 103.  
 Castle Braid Co., Brooklyn, N. Y. (S) 161.  
 Caswell, E. C. & Co., Bloomsburg, Pa. (W) 233.  
 Cataract Hair Cloth Co., Niagara Falls, N. Y. (C) 178.  
 Catawba Cotton Mill, Newton, N. C. (C) 193.  
 Catawba Woolen Mills, Plateau, N. C. (W) 193.  
 Cating, James, Maspeth, N. Y. (J) 172.  
 Catotr Silk Co., New York, N. Y. (S) 174.  
 Cavanaugh, Wm. M., Birdsboro, Pa. (K) 233.  
 Cavendon, Joseph & Theophile Guerin (Falls Yarn Mills) 261.  
 Caven, J., The Co. (Saranac Mills) 225.  
 Cavendish Woolen Mills (Gay Bros. Co.) 275.  
 Caves, Thos. & Sons, Phila., Pa. (W) 209.  
 Cawthon Cotton Mill Co., Selma, Ala. (C) 70.  
 Cayadutta Knitting Mills, Fonda, N. Y. (K) 169.  
 Cazenovia Woolen & Felt Co., Cazenovia, N. Y. (W) 166.  
 Cedar Bluff Woolen Co., Cedar Bluff, Va. (W) 276.  
 Cedar Cliff Silk Co., Haledon, N. J. (S) 151.  
 Cedar Falls Mfg. Co., Cedar Falls, N. C. (C) 185.  
 Cedar Grove Mill (Wm. Whitaker & Sons) 229.  
 Cedar St. Dye & Bleach Works (Wm. Kedward) 219.  
 Cedarburg Woolen Mills, Cedarburg, Wis. (W) 280.  
 Cedartown Cotton Co., Cedartown, Ga. (C) 86.  
 Celeste Cotton Mill, Celeste, Texas (C) 271.  
 Centennial Carpet Mills (Samuel White) 229.  
 Centerville Cotton Mill, Centerville, R. I. (C) 253.  
 Central Knitting Co., Brooklyn, N. Y. (K) 164.  
 Central Knitting Co., Cleveland, Ohio (K) 198.  
 Central Knitting Mills (J. Wiess) 178.  
 Central Knitting Mills, Millheim, Pa. (K) 241.  
 Central Knitting Works (Mrs. N. Jerome Keefer) 166.  
 Central Mills, Sylaruga, Ala. (C) 70.  
 Central Mills Co., Southbridge, Mass. (C) 130.  
 Central Silk Finishing Co., Paterson, N. J. (F) 154.  
 Central Woolen Co., Stafford Springs, Conn. (W) 80.  
 Centre Hosiery Mills (Harry R. Smalley) 226.  
 Centre Point Woolen Mills, Centre Point, ArE. (W) 70.  
 Centre Woolen Mills (Geo. E. Beck) 233.  
 Centredale Worsted Mills, Centredale and Stillwater, R. I. (W) 253, 259.  
 Centreport Knitting Mill, Centreport, Pa. (K) 224.  
 Centreville Mfg. Co., Rockville, R. I. (C) 259.  
 Century Cotton Mills, So. Boston, Va. (C & K) 278.  
 Century Knitting Co., Spring City, Pa. (K) 248.  
 Century Tapestry Mills, Philadelphia, Pa. (C) 209.  
 Century Throwing Co., Paterson, N. J. (S) 155.  
 Chace Mill, Moodus, Conn. (C) 76.  
 Chace Mills, Fall River, Mass. (C) 116.  
 Chadbourne & Moore, Chelsea, Mass. (C) 114.  
 Chadburn & Smith, Brooklyn, N. Y. (K) 164.  
 Chaddock, G. W. & Sons, Magnolia, O. (W & K) 199.  
 Chadwick, James & Bro., Ltd., Jersey City, N. J. (C) 151.  
 Chadwick Mfg. Co., Charlotte, N. C. (C) 185.  
 Chadwick's Mills Co., Chadwick's, N. Y. (C) 166.  
 Chaffee, A. D., Willimantic, Conn. (S) 83.  
 Chaffee, O. S. & Son, Mansfield Centre, Conn. (S) 76.  
 Chamberlin, John P. (Seneca Woolen Mills) 150.  
 Chambers, Joseph, Philadelphia, Pa. (W) 209.  
 Chambersburg Hosiery Co., Chambersburg, Pa. (K) 235.  
 Chambersburg Woolen Co., Chambersburg, Pa. (W) 235.  
 Champion Knitting Mill (J. E. Stanton) 246.  
 Champion Silk Co., Pottstown, Pa. (S) 244.  
 Champlain Silk Mills, Whitehall, N. Y. (S) 184.  
 Chant, T. N., Port Jervis, N. Y. (S) 179.  
 Chapel Mills Mfg. Co., Cherry Valley, Mass. (W) 114.  
 Chapman Mills, East Putnam, Conn. (W) 75.  
 Charavay & Bodvin, New York, N. Y. (F) 174.  
 Charles River Woolen Co., No. Bellingham, Franklin, Mass. (W) 119, 128.  
 Charleston Bagging Mfg. Co., Charleston, S. C. (C) 262.  
 Charlotte Cordage Co., Charlotte, N. C. (C) 185.  
 Charlotte Cotton Mills, Charlotte, N. C. (C) 185.

- Charlotte Dye Works, Philadelphia, Pa. (D) 209.  
Charlotte Oil & Fertilizer Co., Charlotte, N. C. (C) 185.  
Charlottesville Woolen Mills, Charlottesville, Va. (W) 276.  
Charmwood Hosiery Co., Philadelphia, Pa. (K) 209.  
Charter Hosiery Mfg. Co., Philadelphia, Pa. (K) 209.  
Chase, E. & F. (Chase Woolen Co.) 107.  
Chase Woolen Co., Waterville, Maine (W) 107.  
Chase Woolen Mills, Webster, Mass. (W) 133.  
Chase & Mathewson (Buffalo Weaving Co.) 168.  
Chase & Pigeon, Pawtucket, R. I. (K) 255.  
Chatham Mfg. Co., Elkin, N. C. (W & C) 188.  
Chatham Mills (Mullineux, Clegg & Co.) 222.  
Chautauqua Knitting Mills, Falconer, N. Y. (K) 168.  
Chautauqua Towel Mills, Jamestown, N. Y. (C) 170.  
Chautauqua Worsted Mills, Jamestown, N. Y. (W) 170.  
Cheboygan Carpet & Rug Works, Cheboygan, Mich. (W) 137.  
Chegnay, Henri Co., New York, N. Y. (D) 174.  
Chelsea Cordage Co., Chelsea, Mass. (J) 114.  
Chelsea Jute Mills, Brooklyn, N. Y. (J) 164.  
Cheney Bros., So. Manchester, Conn. (S) 80.  
Chepachet Yarn Co., Chepachet, R. I. (W) 253.  
Cherokee Falls Mfg. Co., Blacksburg, S. C. (C) 262.  
Cherokee Knitting Mill, Cedartown, Ga. (K). See Too Late for Classification.  
Cherokee Mill, Mobile, Ala. (C) 69.  
Cherokee Turkey Rod Dye Works, Newton Upper Falls, Mass. (D) 127.  
Cherry Cotton Mills, Florence, Ala. (C) 67.  
Cherryville Mfg. Co., Cherryville, N. C. (C) 187.  
Chesapeake Knitting Mills, Berkley, Va. (K) 276.  
Cheshire Blanket Co., Marlboro, N. H. (W) 146.  
Cheshire Mills Co., Harrisville, N. H. (W) 145.  
Chester Lock Mills (J. Wm. Lewis & Co.) 235.  
Chester Dyeing Co., Ltd., Chester, Pa. (D) 235.  
Chester, E. G. Dyeing Co., Philadelphia, Pa. (D) 209.  
Chester, E. G. Hosiery Co., Philadelphia, Pa. (K) 209.  
Chester Knitting Co., Spring City, Pa. (K) 248.  
Chester Mfg. Co., Chester, Pa. (C) 235.  
Chester Suspender Co., Boston, Mass. (C W & S) 112.  
Cheswell Cotton Mill Co., The, Westminster, S. C. (C) 268.  
Chewalla Cotton Mills, Eufaula, Ala. (C) 67.  
Chicago Embroidery Co., Chicago, Ill. (S) 93.  
Chicago Fringe and Embroidery Co., Chicago, Ill. (S) 93.  
Chicago Glove and Mitten Co., Chicago, Ill. (K) 93.  
Chicago Hosiery Co., Detroit, Mich. (K) 137.  
Chicago Net & Twine Co., Chicago, Ill. (C) 93.  
Chicago-Rockford Hosiery Co., Kenosha, Wis. (K) 281.  
Chicago Rug Mfg. Co., Chicago, Ill. (W) 93.  
Chicamauga Knitting Mills, Chattanooga, Tenn. (K) 269.  
Chicopee Mfg. Co., Chicopee Falls, Mass. (C) 114.  
Chicora Cotton Mills, Rock Hill, S. C. (C) 267.  
Chillicothe Hosiery Mills, Chillicothe, Ohio (K) 197.  
China Mfg. Co., Suncook, N. H. (C) 147.  
Chinnabee Cotton Mills, Talledega, Ala. (C) 70.  
Chipman's, Chas. Sons, Easton, Pa. (C & K) 237.  
Chippewa Falls Woolen Mills, Chippewa Falls, Wis. (W) 280.  
Chiquola Cotton Mills. See too late for classification list.  
Chrisman, W., Colemans, N. Y. (W) 168.  
Christ Bros. Mfg. Co., Philadelphia, Pa. (W) 209.  
Chronicle Mills, The, Belmont, N. C. (C) 184.  
Chrystal Spring Dye & Bleach Works, Shoemaker'sville, Pa. (D & B) 247.  
Chutanunda Mills (Stewart, John K.) 163.  
Church's Woolen Mill (H. K. Wright) 184.  
City Mfg. Corp., New Bedford, Mass. (C) 126.  
City Mills (Am. Felt Co.) 127.  
Clapp, William, Phila., Pa. (W) 209.  
Claremont Cotton Mill, Claremont, N. C. (C) 187.  
Claremont Woolen Co., Claremont, N. H. (W) 143.  
Clarendon Woolen Co., Passaic, N. J. (W) 153.  
Clark, B. A., Sloucmville, R. I. (W) 259.  
Clark, H. D., Mt. Carmel, Conn. (S) 77.  
Clark Hose Co., Malden, Mass. (C) 124.  
Clark, J. D. Co., Rochdale, Mass. (W) 129.  
Clark Mile End Spool Cotton Co., Newark, N. J. (C) 152.  
Clark Textile Co., Sidney, N. Y. (S) 181.  
Clark Thread Co., The, Newark, N. J. (C) 152.  
Clark, Wm. Mills, Westerly, R. I. (C) 260.  
Clark & Barber, Philadelphia, Pa. (K) 209.  
Clark & Co., Spigner Station, Ala. and Augusta, Ga. (C) 70, 86.  
Clark & Holsapple Mfg. Co., Cohoes, N. Y. (K) 167.  
Clark, Thos., Paterson, N. J. (D & F) 155.  
Clark, Wm., Philadelphia, Pa. (C) 209.  
Clarksburg Woolen Mill, Clarksburg, W. Va. (W) 279.  
Clasgens, The J. & H. Co., New Richmond, O. (W) 200.  
Clayton Cotton Mill, Clayton, N. C. (C) 187.  
Clayton, Thomas, Lockport Station, Pa. (W) 240.  
Clayville Co., Rockland, R. I. (D B1 & F) 259.  
Clear Water Bleaching & Mfg. Co., Augusta, Ga. (B1) 85.  
Cleland, Robt. & Sons, Phila., Pa. (W) 209.  
Clegg Mfg. Co., The, Columbus, Ga. (C) 86.  
Clegg, Wm. & Sons, Philadelphia, Pa. (W) 209.  
Clemens, W. A. (Buffalo Batting Mill) 166.  
Clemson College, Clemson College, S. C. (C & W) 263.  
Clermont Woolen Mills (The J. & H. Clasgens Co.) 200.  
Cleveland Cotton Mills, Lawndale, N. C. (C) 191.  
Cleveland Woolen Mills (The Collings, Taylor Co.) 198.  
Cleveland Woolen Mills, Cleveland, Tenn. (W) 269.  
Cleveland Worsted Mills Co., Cleveland, O. (W) 193.  
Cliffe, Arthur, Paterson, N. J. (S) 155.  
Clifford, C. A., Hollis Depot, N. H. (K) 145.  
Cliffside Mills, Henrietta, N. C. (C) 190.  
Clifton Hosiery Mills Co., Norfolk, Va. (K) 277.  
Clifton Mfg. Co., Clifton, S. C. (C) 263.  
Clifton Mills (B. Wink & Co.) 230.  
Clifton, S. E. & Co., Cohoes, N. Y. (K) 167.  
Clifton Silk Mills, Washawken, N. J. (S) 159.  
Clifton Woolen Mills, Clifton Forge, Va. (W) 276.  
Clinton Braid Co., Clinton, Mass. (C) 111.  
Clinton Cotton Mills, Clinton, S. C. (C) 263.  
Clinton Cotton Mills, Clinton, La. (C) 101.  
Clinton Knitting Co., Clinton, Mich. (K) 137.  
Clinton Knitting Mill, Syracuse, N. Y. (K) 181.  
Clinton Knitting Mills, Aletown, Pa. (K) 231.  
Clinton Mfg. Co., Woonsocket, R. I. (C) 260.  
Clinton Mfg. Co., Brooklyn, N. Y., (J) 164.  
Clinton Mills Co., Norwich, Conn. (W) 78.  
Clinton Woolen Mfg. Co., Clinton, Mich. (W) 137.  
Clinton Worsted Co., Clinton, Mass. (W) 114.  
Clough, Jos. Sons & Co., Phila., Pa. (D) 209.  
Clouse, W. H., Maria, Pa. (W) 240.  
Clover Cotton Mfg. Co., Clover, S. C. (C) 263.  
Clover Knitting Co., Waterford, N. Y. (K) 183.  
Clover Leaf Knitting Mill (Kutz Bros.) 237.  
Clow, Wm. & Son, Lakeport, N. H. (K) 145.  
Clowes, Southern Co., Paterson, N. J. (S) 155.  
Clyde Bleachery & Print Works, River Point, R. I. (B1 & D) 259.  
Clymer, Lee S., Riegelsville, Pa. (K) 246.  
Coaquanoek Mills (C. M. Brown & Co.) 207.  
Coates, J. & P., Ltd. (Conant Thread Co.) 256.  
Coates, William, Mrs., Philadelphia, Pa. (W) 209.  
Cobb, A. H. & W. E. (Suffolk Knitting Mills) 273.  
Cobbossecotee Woolen Co., Gardiner, Me. (W) 103.

- Cochecho Mfg. Co., Dover, N. H. (C, Pr & BD) 113.  
 Cochecho Wln. Mfg. Co., East Rochester, N. H. (W) 113.  
 Cochran Cotton Mill Co., Cochran, Ga. (C) 86.  
 Cochran, C. B., Antrim, N. H. (C & S) 143.  
 Cochrane, Chas. P., Philadelphia, Pa. (W) 211.  
 Cochrane Mfg. Co. (Danielsonville Cotton Mill, Norfolk Mill) and Malden, Mass. (C W & P D & B) 73, 115, 124.  
 Codorus Woolen Mills (A. B. Wertz) 234.  
 Coffeyville Cotton Mfg. Co., Coffeyville, Kansas (C) 99.  
 Cogar Hemp Co., The Geo., Danville, Ky. (FD) 100.  
 Cohankus Mfg. Co., Paducah, Ky. (C) 101.  
 Cohannet Mills, Taunton, Mass. (C) 131.  
 Cohen Bros., Paterson, N. J. (S) 155.  
 Cohn, H., New York, N. Y. (S) 174.  
 Cohoes Dye Wks., Cohoes, N. Y. (D) 167.  
 Cohoes Knitting Co., Cohoes, N. Y. (K) 167.  
 Cohoes Shoddy Mill (Wm. Lowenthal & Co.) 167.  
 Cold Spring Bleaching & Finishing Works, Yardley, Pa. (Bl & F) 250.  
 Cole, Senior & Co., Medway, Mass. (W) 124.  
 Cole, Zach, Paterson, N. J. (C) 155.  
 Coleman Mfg. Co., Concord, N. C. (C) 187.  
 Coleman, W. C., Sabetha, Kansas (K) 100.  
 Coley Carpet & Rug Co., Fountain City, Wis. (W) 281.  
 Collanad Dye Works (T. McCauley) 221.  
 Collard, A., Philadelphia, Pa. (K) 211.  
 College Point Silk Dyeing Co., College Point, N. Y. (D) 168.  
 College Point Silk Dyeing Works (Wchrlin & Brugger) 168.  
 Collett & Ingle, Athens, Ga. (K) 85.  
 Colleton Cotton Mills, The, Walterboro, S. C. (C) 268.  
 Collinge & Nolan Co., Paterson, N. J. (S) 155.  
 Collings, Taylor Co., The, Cleveland, O. (K) 198.  
 Collingwood Mills (Folwell Bro. & Co.) 215.  
 Collins, D. M. & Co., Pittsfield, Mass. (K) 129.  
 Collins, E. & Co., Malden, Mass. (K) 124.  
 Collins, John S. & Co., Gilsun, N. H. (W) 145.  
 Collins, Lawrence, Philadelphia, Pa. (W) 211.  
 Collins & Aikman Co., Philadelphia, Pa. (W) 211.  
 Collins & Harding, Waltham, Mass. (K) 132.  
 Collyer Insulated Wire Co., Pawtucket, R. I. (C) 255.  
 Colombat, Albert & Co., San Francisco, Cal. (S) 71.  
 Colonial Woolen Co., Trenton, N. J. (W) 159.  
 Colton, Geo. S., Easthampton, Mass. (C) 115.  
 Columbia Carpet Mills (Hugh Nelson) 223.  
 Columbia Cotton Mills, Columbia, Ala. (C) 67.  
 Columbia Cotton Mill Co., Columbia, Tenn. (C) 265.  
 Columbia Dye Works (E. J. Diller) 213.  
 Columbia Finishing Works (J. C. Haigh & Co.) 216.  
 Columbia Hosiery Co., New York, N. Y. (K) 174.  
 Columbia Hosiery Mills, Columbia, S. C. (K) 263.  
 Columbia Knitting Mills (Levy, Stiefel Co.) 176.  
 Columbia Knitting Mills, Rome, N. Y. (K) 180.  
 Columbia Knitting Mills, Clifton Heights, Pa. (K) 225.  
 Columbia Knitting Mill Co., The, Kinderhook, N. Y. (K) 171.  
 Columbia Knitting Works (C. Flesch) 174.  
 Columbia Lace Co., Columbia, Pa. (C) 236.  
 Columbia Mfg. Co., Ramseur, N. C. (C) 194.  
 Columbia Mfg. Co., Everett, Mass. (C) 116.  
 Columbia Mill (Hyndman & Moore Co.) 218.  
 Columbia Mill (A. D. Irwin & Bro.) 218.  
 Columbia Mills, Lewiston, Maine (W) 105.  
 Columbia Mills Co., Columbia, S. C. (C) 263.  
 Columbia Narrow Fabric Co., Shannock, R. I. (C & S) 259.  
 Columbia Ribbon Co., Haledon, N. J. (S) 151.  
 Columbia Silk Mills, East Greenville (S) 237.  
 Columbia Weaving Co., College Point, N. Y. (S) 168.  
 Columbia Worsted Co., Wallingford, Pa. (W) 249.  
 Columbian Cordage Co., Auburn, N. Y. (J) 163.  
 Columbian Mfg. Co., Greenville, N. H. (C) 145.  
 Columbia Spinning Co., Philadelphia, Pa. (C) 211.  
 Columbiaville Woolen Mills, Columbiaville, Mich. (W) 127.  
 Columbus Hosiery Mills, Columbus, Miss. (K) 140.  
 Columbus Mfg. Co., Columbus, Ga. (C) 86.  
 Columbus Woolen Mills Co., Columbus, O. (W) 198.  
 Colwell, R. & Co., Providence, R. I. (W) 257.  
 Comby Silk Mills, West Hoboken, N. J., and Renova, Pa. (S) 159, 216.  
 Comins & Co., Rochdale, Mass. (W) 129.  
 Commercial Knitting Mills Co., Cohoes, Troy, N. Y. (K) 167, 181.  
 Common Sense Truss Co., Chicago, Ill. (K) 93.  
 Commonwealth Cotton Mfg. Co., Durham, N. C. (C) 188.  
 Conanicut Mills, Fall River, Mass. (C) 116.  
 Conant, Houghton & Co., Littleton, Mass. (C) 122.  
 Conant Mfg. Co., Centocook, N. H. (S) 143.  
 Conant Thread Co., Pawtucket, R. I. (C) 256.  
 Concord Mfg. Co., Penacook, N. H. (W) 147.  
 Concord Woolen Mill, Nicotack, Ga. (W) 90.  
 Conde, Fred, Oswego, N. Y. (K) 179.  
 Conde, Swits Co., The, Oswego, N. Y. (K) 179.  
 Condon, A. C. & Co., Penobscot, Me. (K) 106.  
 Conestogo Steam Mills, Lancaster, Pa. (C) 239.  
 Congdon, George, Fall River, Mass. (C) 116.  
 Connecticut Twine & Cordage Mfg., Turnerville, Conn. (J) 81.  
 Connecticut Webb Co., The, Bridgeport, Conn. (C) 73.  
 Connelly, James & Sons, Philadelphia, Pa. (C) 211.  
 Connewawah Spinning Co., Elmira, N. Y. (C) 168.  
 Conshohocken Dyeing & Finishing Works (Kennedy & Britz) 219.  
 Conshohocken Wln. Co., West Conshohocken, Pa. (W) 249.  
 Consolidated Hosiery & Finishing Co., Philadelphia, Pa. (K & F) 211.  
 Consolidated Woolen & Felt Mills, Amsterdam, N. Y. (W) 161.  
 Consumers' Silk Co., Paterson, N. J. (S) 155.  
 Continental Carpet Mill (Edward Weber) 229.  
 Continental Dye Works (T. A. Harris & Co.) 217.  
 Continental Ktg. Co., Cohoes, N. Y. (K) 167.  
 Continental Mills, Lewiston, Maine (C) 105.  
 Centocook Mills, Hillsboro Bridge, N. H. (K) 115.  
 Centreville Mfg. Co., Manville, R. I. (C & W) 254.  
 Converse, D. E., Co., Glendale, S. C. (C) 265.  
 Conway, R. W., Canton, N. Y. (W & D) 166.  
 Cook, T. & R. P., Tippecanoe, Pa. (W & K) 248.  
 Coolceeme Cotton Mills, Coolceeme, N. C. (C) 187.  
 Cooper, Chas., Bennington, Vt. (K) 273.  
 Cooper Mfg. Co., Bennington, Vt. (K) 273.  
 Cooper Mercerizing Co., Providence, R. I. (D) See Too Late Classification List.  
 Cooper Underwear Co., Kenosha, Wis. (K) 281.  
 Cooper, Wells & Co., St. Joseph, Mich. (K) 129.  
 Cosa Mfg. Co., Piedmont, Ala. (C) 69. Also See Too Late for Classification List.  
 Cope, E. M. & Co. (Cope Knitting Mills) 211.  
 Cope Knitting Mills, Philadelphia, Pa. (K) 211.  
 Coplay Knitting Mill Co., Coplay, Penn. (K) 236.  
 Cra Cotton Mills, The, King's Mountain, N. C. (C) 191.  
 Cora Mfg. Co., Haw River, N. C. (C) 190.  
 Coral Mfg. Co., Norristown, Pa. (W) 212.  
 Cordaville Woolen Co., Cordaville, Mass. (W) 115.  
 Cordingly, W. S. & F. (Siurian Mills) 127.  
 Cordis Mill, Millbury, Mass. (C) 125.  
 Cornelius Cotton Mills, Davidson, N. C. (C) 187.  
 Cornell Knitting Co., Rondout, N. Y. (K) 180.  
 Cornell Mills, Fall River, Mass. (C) 116.  
 Cornell Stocking Co., New Bedford, Mass. (K) 126.  
 Cornell, Thos. L. (Patent Cloth Spanging & Finishing Co) 177.  
 Cornelson, Geo. H., Orangeburg, S. C. (C) 266.  
 Cornforth & Marx, Paterson, N. J. (S) 155.



- Coronet Silk Mfg. Co., Paterson, N. J. (S) 155.  
 Coronet Worsted Co., Oakland, R. I. (W) 255.  
 Corr Mfg. Co., Taunton, Mass. (C) 131.  
 Corsicana Cotton Factory Co., Corsicana, Texas (C) 271.  
 Corticelli Silk Mills, Florence, Mass. (S) 119.  
 Cotter & O'Keefe, Philadelphia, Pa. (D) 211.  
 Cotton Oil & Fibre Co., Norfolk, Va. (C) 277.  
 Couch & Moreland, Blain, Pa. (K) 233.  
 Coulter and Lowry, Greensboro, N. C., Philadelphia, Pa. (F) 190, 211.  
 Courtenay Mfg. Co., The Newry, S. C. (C) 266.  
 Coventry Co., Anthony, R. I. (C) 251.  
 Coventry Worsted Mills, Washington, R. I. (W) 260.  
 Coverdill, E. R., Clifton Heights, Pa. (W) 235.  
 Covington Cotton Mills, Covington, Ga. (C) 88.  
 Covington Woolen Mills, Covington, O. (W) 199.  
 Covington Woolen Mills Co., Covington, Ky. (W) 200.  
 Cowan Woolen Co., Lewiston, Maine (W) 105.  
 Cowpens Mfg. Co., Cowpens, S. C. (C) 263.  
 Cox, Geo. S. & Bro., Philadelphia, Pa. (C) 211.  
 Cox Mfg. Co., Anderson, S. C. (C) 262.  
 Crabtree and Patchett, Montgomery and Newburgh, N. Y. (W) 172.  
 Cramer and King Printing Co., Paterson, N. J. (Pr, D & F) 155.  
 Crane Bros., Dalton, Mass. (C) 115.  
 Crane, B. F., West Millbury, Mass. (K) 133.  
 Crane Felt Mfg. Co., Belvidere, N. J. (W) 148.  
 Crane, John W. (Newington Knitting Works) 77.  
 Cranska, Floyd, Moosup, Conn. and Worcester, Mass. (C) 77, 124.  
 Cranska Thread Co., Worcester, Mass. (C) 134.  
 Cranston, Benj., Woolen Mills, Wheelersburg, O. (W & K) 201.  
 Cranston Print Works Co., Cranston, R. I. (Pr) 253.  
 Cranston Worsted Mills, Bristol, R. I. (W) 251.  
 Crawford Woolen Co., Martinsburg, W. Va. (W) 279.  
 Crawford & Carney, Bennington, Vt. (W) 273.  
 Crawford & Tyler, No. Dana, Mass. (W) 128.  
 Crawshaw Co., The, Newburgh, N. Y. (W) 172.  
 Creamer, W. J., Penobscot, Me. (K) 106.  
 Credential Mfg. Co., Philadelphia, Pa. (K) 211.  
 Crefeld Mills (Lorraine Mfg. Co.) 260.  
 Crefeld Waste and Batting Co., Saylesville, R. I. (C) 259.  
 Crescent Co., New York, N. Y. (K) 174.  
 Crescent Hat Co., Fall River, Mass. (W) 116.  
 Crescent Hosiery Co., Scotland Neck, N. C. (K) 195.  
 Crescent Hosiery Mills (W. F. Short) 226.  
 Crescent Knitting Mill (G. W. Unger) 234.  
 Crescent Knitting Mill (Theo. E. Kremer & Co.) 220.  
 Crescent Worsted Co., Lawrence, Mass. (W) 122.  
 Crescent Worsted Mill (Langewald, F. A. W.) 125.  
 Cressy Thread Co., Holyoke, Mass. (C) 120.  
 Crew's Silk Finishing & Piece Dye Works, Paterson, N. J. (D & F) 155.  
 Criterion Knitting Co., Lowell, Mass. (K) 123.  
 Crockett, T. T. (Carillon Woolen Mill) 102.  
 Croft, Howland, Son & Co. (Linden Worsted Mills) 149.  
 Croft Mfg. Co., Aiken, S. C. (C) 262.  
 Crompton Co., Crompton, R. I. (C, D & F) 253.  
 Crompton Mill (J. A. Campbell & Bro.) 209.  
 Crompton Mills (Shaw & Bowen) 226.  
 Crosby Mfg. Co., Glastonbury, Conn. (W) 75.  
 Crossingham, James H., Philadelphia, Pa. (K) 211.  
 Crossingham Knitting Mills (James H. Crossingham) 211.  
 Crouch, E., Paris, Idaho (K) 92.  
 Crouse, Charles E. (Oak Knitting Co.) 181.  
 Crouse, Holmes & Holmes (Fulton County Silk Mills) (S & K) 169.  
 Crowder Mountain Cotton Mills, King's Mountain, N. C. (C) 191.  
 Crowe, Alexander (Caledonia Carpet Mill and Caledonia Worsted Mill) 269.  
 Crowley, M. T. (Crowley's Mills) 185.  
 Crowley's Mills, Charlotte, N. C. (C) 185.  
 Crown Carpet Lining Co., Providence, R. I. (C) 257.  
 Crown Cotton Mills, Dalton, Ga. (C) 88.  
 Crown Knitting Co., Philadelphia, Pa. (K) 211.  
 Crown Knitting Co., The, Reading, Pa. (K) 244.  
 Crown Knitting Mill (James H. Wagner & Co.) 241.  
 Crown Mills, Marcellus, N. Y. (W) 172.  
 Crown Point Knitting Co., Crown Point, N. Y. (K) 168.  
 Crown Worsted Mills, Providence, R. I. (W) 258.  
 Crozer, S. A. & Son, Upland, Pa. (C) 249.  
 Crozer's, J. P. Sons, Upland, Pa. (C) 249.  
 Crum Lynne Worsted Mills (S. Loughbottom & Sons) 236.  
 Crystal Knitting Mills, Slatington, Pa. (K) 247.  
 Crystal Spring Dyeing & Bleaching Co., Fall River, Mass. (Bl, Pr & D) 116.  
 Cuba Knitting Co., Milwaukee, Wis. (K) 281.  
 Cuero Cotton Mill, Cuero, Texas (C) 271.  
 Cuero Hosiery Mfg. Co., Cuero, Texas (K) 271.  
 Culbertson, John & Sons, Philadelphia, Pa. (C & W) 211.  
 Cumberland Cotton Mills Co., Cumberland, N. C. (C) 187.  
 Cumberland Gap Woolen Mills (A. B. Kesterson) 269.  
 Cumberland Knitting Mills, Knoxville, Tenn. (K) 270.  
 Cumberland Mill, Lewiston, Me. (W) 105.  
 Cumberland Mills Co., Valley Falls, R. I. (C) 260.  
 Cunningham, Jas. & Son, Oriskany Falls, N. Y. (K) 178.  
 Currie, Daniel, Philadelphia, Pa. (W) 211.  
 Currie Thread Co., Keyport, N. J. (C) 152.  
 Curry, William, Slippery Rock, Pa. (W) 247.  
 Curtis Mfg. Co., Worcester, Mass. (W) 134.  
 Curtis & Spindell Co., Lynn, Mass. (K) 124.  
 Curtiss, Daniel, Sons, Woodbury, Conn. (W) 82.  
 Cushman, S. F. & Sons, Monson, Mass. (W) 125.  
 Cussons, J. M., Chaffield, Minn. (W) 129.  
 Custom Knitting Works, Chicago, Ill. (K) 93.  
 Cutler Bros. Co., Salt Lake City, Utah (K) 273.  
 Cutler, E. A., Packerville, Conn. (C) 78.  
 Cutler Mfg. Co., Warren, R. I. (C) 260.  
 Cylindrograph Embroidery Co., Bridgeport, Conn. (W) 73.  
 Dady, I. A. Corporation, Putnam and So. Coventry, Conn. (S) 73, 80.  
 Dalsey Hosiery Mills, Burlington, N. C. (K) 185.  
 Dalby, Thos. Co., Newton, Mass. (K) 126.  
 Dale, Mrs. Margaret, Arlington, Mass. (C) 111.  
 Dale, Wm. Henry, Philadelphia, Pa. (C) 211.  
 Dalecarlid Worsted Mill, Peace Dale, R. I. (W) 257.  
 Daleville Mills (Dennison Walker) 75.  
 Dakeith Mills (Bradbury Bros.) 205.  
 Dallas Cotton Mills, Dallas, N. C. (C) 187.  
 Dallas Cotton Mills, Dallas, Tex. (C) 271.  
 Dallas Mfg. Co., Huntsville, Ala. (C) 69.  
 Dallas, Robt., Philadelphia, Pa. (C) 211.  
 Dalton Woolen Mill (Reddick, W. H. & Co.) 115.  
 Dalzell, Isaac, Philadelphia, Pa. (K) 211.  
 Dana Warp Mills, Westbrook, Me. (C) 107.  
 Danby & Fetterolf, Philadelphia, Pa. (W) 211.  
 Daniel Mfg. Co., Lincolnton, N. C. (C) 192.  
 Daniels, John, Stafford, Ohio (W) 200.  
 Danielson Worsted Co., The, Danielson, Conn. (W). See Too Late for Classification List.  
 Danielsville Cotton Mill, Danielson, Conn. (C) 73.  
 Danvers Bleachery & Dye Works, Peabody, Mass. (Bl & D) 129.  
 Danville Knitting Mills, Danville, Va. (K) 276.  
 Danville Knitting Mills Co., Danville, Pa. (K) 236.  
 Danville Woolen Mill, Danville, Ill. (W) 95.  
 Dardanelle Cotton Mills, Dardanelle, Arkansas (C) 70.  
 Darling, A. W., Cherry Valley and Worcester, Mass. (W) 114, 134.

- Darlington Mfg. Co., Darlington, C. H., S. C. (C) 263.
- Darrow, A. R. (Tabor Rock Mill) 75.
- Dartmouth Mfg. Corp., New Bedford, Mass. (C) 126.
- Dauberville Knitting Mills, Dauberville, Pa. (K) 226.
- Dauntless Yarn Mills (Geo. Grayson) 236.
- Dauphin Hosiery Co., Steelton, Pa. (K) 248.
- Dauphin Mills (James Pollock & Son) 224.
- Davenport, John, Philadelphia, Pa. (W) 211.
- Davenport Mills (E. Bakes) 203.
- Davenport Mills (Joseph Derk & Co.) 211.
- Davenport Woolen Mills Co., Davenport, Iowa (W) 99.
- Davidson, Walter (Richmond Woolen Mill) 138.
- Davidson & Brooke, Philadelphia, Pa. (B) 211.
- Davies Textile Co., Philadelphia, Pa. (C) 211.
- Davis, Botton & Co., North Wilbraham, Mass. (W) 128.
- Davis, C. M. & Co., Gouldsboro, Vt. (W) 275.
- Davis Cotton Mills, Augusta, Ga. (C) 85.
- Davis-Crews Ktg. Mill, The Kernersville, N. C. (K) 191.
- Davis, Henry A. & Sons, Providence, R. I. (W) 258.
- Davis Mills, Fall River, Mass. (C) 116.
- Davis, W. S., Philadelphia, Pa. (C) 211.
- Davis & Brown Woolen Co., Killingly, Conn. (W) 76.
- Davis & Hancock, Philadelphia, Pa. (C) 211.
- Davis & Quick, Brooklyn, N. Y. (D, B) & (F) 164.
- Davitt, A. W. (Mohawk River Mills) 167.
- Davol Mills, Fall River, Mass. (C) 116.
- Dawson, J. & E., Philadelphia, Pa. (C) 211.
- Dawson Mfg. Co., Holden & Holliston, Mass. (W) 120.
- Dawson, Thomas & Co., Philadelphia, Pa. (D) 211.
- Day, F. J. & Co., Paterson, N. J. (S) 155.
- Dayville Woolen Co., Killingly, Conn. (W) 76.
- Dean, L. L. & Co., Amsterdam, N. Y. (K) 161.
- Dearnley, John H., Philadelphia, Pa. (W) 211.
- Deckerville Woolen Mill, Deckerville, Mich. (W) 127.
- Deering Harvester Co., Chicago, Ill. (J) 93.
- Defiance Knitting Mills (Wertheimer & Hollander) 178.
- Defiance Woolen Mills, Defiance, Ohio (W) 139.
- De Ford, R. D. & Son, Olive Hill, Tenn. (W) 270.
- Degener, A. & R. J. Steiner, Paterson, N. J. (S).
- De Gray & Co., Midland Park, N. J. (S) 152.
- See Too Late for Classification List.
- Deihert & Wilson, Elkton, Md. (C) 108.
- Deisher, H. K., Kutztown, Pa. (K) 239.
- De Kalb Cotton Mills, Camden, S. C. (C) 262.
- Delabarre Mill, Conway, Mass. (W) 115.
- Delaware Carpet Mills (Schofield, Mason & Co.) 226.
- Delaware Cotton Co., Wilmington, Del. (C) 84.
- Delaware Knitting Mill (Chas. E. Krenner) 219.
- Delaware Mfg. Co., Chester, Pa. (W) 235.
- Delgado Cotton Mills Co., Wilmington, Del. (C) 196.
- Delhi Silk Co., Delhi, N. Y. (S) 168.
- Delima Cotton & Woolen Mills, Lincolnton, N. C. (C & W) 192.
- Delph Spinning Co., The, Philadelphia, Pa. (C) 211.
- Delwood Mill, Philadelphia, Pa. (W) 211.
- De Lyte Tapestry Mills, Philadelphia, Pa. (C & S) 211.
- Dempsey Bleachery & Dye Works, Pawtucket, R. I. (B), (D) & (F) 256.
- Dennard & Hughes (Houston Factory) 88.
- Denver Woolen Mills, Denver, Mo. (W) 141.
- Derby Cotton Mills (R. F. Adams) 79.
- Derk, Joseph & Co., Philadelphia, Pa. (C) 211.
- Dery, D. G., Catawauqua and East Mauch Chunk, Pa. (S) 231, 237.
- Des Moines Hosiery Mills, Des Moines, Iowa (K) 59.
- Detroit-Alaska Knitting Mills, Detroit, Mich. (K) 127.
- Detroit Cotton Batting Co., Detroit, Mich. (C) 137.
- Deutsch, Chas., New York, N. Y. (K) 174.
- Devaney Bros., Tremont, Pa. (K) 249.
- Develon's Thos., Sons, Philadelphia, Pa. (W) 211.
- Devlin, Chas., Philadelphia, Pa. (C & W) 211.
- Devon Mills (Chas. P. Cochrane) 211.
- Devonshire Mills, Goff's Falls, N. H. (W) 145.
- Dewey Co., A. G., Quechee, Vt. (W) 275.
- Dews, C. A. (Ellsworth Wm. Mills) 103.
- Dews Woolen Co., North Dexter, Me. (W) 103.
- Dexter Dyeing & Carbonizing Works (E. A. Townsend & Co.) 228.
- Dexter, Lambert & Co., Paterson, N. J. and Honesdale and Hawley, Pa. (S) 155, 238, 239.
- Dexter Yarn Co., Pawtucket, R. I. (C) 256.
- Diamond Knitting Mill (Chas. Hogg & Bro.) 217.
- Diamond Knitting Mills (Himes Underwear Co.) 167.
- Diamond Knitting Mills, Williamstown, Pa. (K) 250.
- Diamond Mills (Meltzgain & Co.) 221.
- Diamond Silk Mill, York, Pa. (S) 250.
- Diamond State Hosiery Co., Wilmington, Del. (K) 84.
- Diana Knitting Co., The, Johnstown, N. Y. (K) 111.
- Dick, Christian, Riverside, N. J. (K & D) 159.
- Dickel, Henry & Son, Philadelphia, Pa. (W) 213.
- Dickey, W. J. & Sons, Oella, Md. (C & W) 109.
- Dickey & McMaster, Philadelphia, Pa. (W) 213.
- Dickson Cotton Mill, Laurinburg, N. C. (C) 191.
- Diefenderfer, W. H. & Co. (Auburn Knitting Mills) 233.
- Diemer, Geo. C., Cleveland, Ohio (W) 198.
- Diez, John G. & Co., Philadelphia, Pa. (W) 213.
- Dill Mfg. Co., The, Abbott Village, Maine (W) 102.
- Diller, E. J., Philadelphia, Pa. (D) 213.
- Dilling Cotton Mills, King's Mountain, N. C. (C) 191.
- Dillon Cotton Mills, Dillon, S. C. (C) 263.
- Dillon Hosiery Mill, Dillon, S. C. (K) 263.
- Dime, Jacob, Paterson, N. J. (S) 155.
- Dimick, J. W. Co., Esopus, N. Y. (W) 168.
- Dixie Cotton Mills, La Grange, Ga. (C) 89.
- Dixie Mills, Lenoir City, Tenn. (K) 270.
- Dixon Mfg. Co., Snow Camp, N. C. (W) 195.
- Dixon, Wm. F., Philadelphia, Pa. (W) 213.
- Doak, Jas., Jr. & Co., Philadelphia, Pa. (W) 213.
- Doak's, Jno. Sons, Philadelphia, Pa. (D) 213.
- Doane, Edward and John (Dalecard) Worsted Mill) 257.
- Dobbins, Geo. D., So. Bethlehem, Pa. (K) 247.
- Doiney, Geo. W. (Taylor's Falls Woolen Mills) 140.
- Dobson, J., Philadelphia, Pa. (W) 213.
- Dobson, John, Philadelphia, Pa. (W) 213.
- Dobson, J. & J., and (Mount Vernon Worsted Mills), Philadelphia, Pa. (W) 213, 222.
- Dobson, John & Jas. (Bradford Mills) 205.
- Dobson, Robt. & Co., Pittsfield, Maine (W) 196.
- Doit Bros., Willoughby, O. (W) 291.
- Dodge-Davis Mfg. Co., Bristol, N. H. (W) 143.
- Dodgeville Mill (Hebron Mfg. Co.) 115.
- Doehler Bros., Village Creek, Iowa (W) 99.
- Doerr, Philip & Sons, Philadelphia, Pa. (W) 213.
- Doherty & Wadsworth, Paterson, N. J. (S) 155.
- Dole, E. & Co., Crompton Village, N. H. (W) 143.
- Dollin Jute Mills, Paterson, N. J. (J) 155.
- Dolman, Albert, Tacoma, Wash. (K) 278.
- Domestic Hosiery Mill, Baltimore, Md. (K) 107.
- Donahoe, M. H. (Shetucket Wstd. Mill) 72.
- Donahue, John & Sons, Paterson, N. J. (W) 155.
- Donlon, John H., Philadelphia, Pa. (W) 213.
- Donohue Dyeing Co., Paterson, N. J. (D) 155.
- Donohue, M. W., Jersey City, N. J. (K) 151.
- Dordoni Silk Dyeing Co., Paterson, N. J. (D) 155.
- Dorgeval Silk Works, Brooklyn, N. Y. (S) 164.
- Dorman & Son, Marlette, Mich. (W) 138.
- Dormer Bros. Co., The, Cincinnati and New Richmond, Ohio (K) 198, 200.
- Dornan Bros., Philadelphia, Pa. (W) 213.
- Dothan Cotton Mill, Dothan, Ala. (C) 67.

- Double Shoal Cotton Mills, Double Shoal, N. C. (C) 188.
- Dover Mill, Philadelphia, Pa. (C & W) 213.
- Dover Yarn Mills, Charlotte, N. C. (C) 185.
- Doweltown Woolen Mill, Doweltown, Tenn. (W) 269.
- Dower, James & Son, Hingham, Mass. (F) 120.
- Dowington Knitting Co., Dowington, Pa. (K) 237.
- Dragon Dye Works, Philadelphia, Pa. (D) 213.
- Drake, Mrs. Nettie B., Winnebago, Ill. (K) 96.
- Draper Bros Co., Canton, Mass. (K & W) 113.
- Draper, W. H. & Son, Troy, N. Y. (C) 181.
- Draper's, Robert, Sons, Canton, Mass. (C & K) 113.
- Drayton Mills Co., Spartanburg, S. C. (C) 267.
- Dreifus, Jacob S., Philadelphia, Pa. (K) 213.
- Dresden Woolen Mills, Dresden, O. (W) 199.
- Dreyfus, Julius & Co., New York, N. Y. (S) 174.
- Drobnitski, Wm. (Empire State Mills) 164.
- Drosin, D. & Sons, New York, N. Y. (K) 174.
- Dryden Blanket Mill, The, Dryden, N. Y. (W) 168.
- Also Too Late for Classification.
- Dublin Cotton Mills, Dublin, Ga. (C) 88.
- Du Bois Knitting Mill (David Reams) 237.
- Duddy Mills, Newton Lower Falls, Mass. (K) 127.
- Duffy Silk Co., The, Buffalo, Fort Plain, Phoenix, N. Y. (S) 166, 169, 179.
- Dufton Bros., Spencer, Mass. (W) 131.
- Dunbar Mills Co., North Adams, Mass. (C) 127.
- Dunbarton Flax Spinning Co., Greenwich, N. Y. (F) 169.
- Duncan, S. D. (Paragon Woolen Mills) 99.
- Duncan, Walter & Co., Lykens, Pa. (K) 240.
- Duncan & Baillie (Cohoes Dye Works) 167.
- Dundee Mills, Hookset, N. H. (C, F & D) 145.
- Dundee Textile Co., Passaic, N. J. (W) 153.
- Dundee Woolen Co., Passaic, N. J. (W) 153.
- Dunham Hosiery Co., Naugatuck, Conn. (K) 77.
- Dunham, J. A., Brooklyn, N. Y. (C) 164.
- Dunlap, Jas. Carpet Co., Philadelphia, Pa. (W) 213.
- Dunlap, John & Son, Philadelphia, Pa. (W) 213.
- Dunlap & Co., Brooklyn, N. Y. (W & S) 164.
- Dunlop Bros. & Co., Spring Valley, N. Y. (S) 181.
- Dunlop's, John, Sons, Spring Valley, N. Y. (S) 181.
- Dunn, Thos. L. C. & Co., Brooklyn, N. Y. (C & J) 164.
- Dunn Worsted Mills, Woonsocket, R. I. (W) 260.
- Dunnell Branch (U. S. Finishing Co.) Pawtucket, R. I. (Pr) 256.
- Duplan Silk Co., So. Bethlehem, Pa. (S) 247.
- Durbiln, J. W. & Sons, Williamstown, Pa. (K) 250.
- Durfee, J. A., Harrisburg, Ill. (W) 95.
- Durfee Mills, Fall River, Mass. (C) 116.
- Durham Cotton Mfg. Co., East Durham, N. C. (C) 188.
- Durham Dyeing Co., Durham, N. C. (D) 188.
- Durham Hosiery Mills, Durham, N. C. (K) 188.
- Durham Knitting Mills (Lee S. Clymer) 246.
- Duryea Silk Mill, Duryea, Pa. (S) 237.
- Dustin Island Woolen Mills, Pennacook, N. H. (W) 147.
- Dustin, J. F. Mfg. Co., Pascoag, R. I. (C) 255.
- Dustin, W. H., Lawrenceburg and Strathmore, Tenn. (C) 270, 271.
- Dutchess Co., Wappinger's Falls, N. Y. (Pr & D) 183.
- Dutchess Hat Works, Fishkill-on-Hudson, N. Y. (W) 169.
- Dutt, Christian & Son, Milltown, Pa. (W) 241.
- Dutton, Jas., Paterson, N. J. (S) 155.
- Dwight Mfg. Co., Alabama City, Ala. and Chocopee, Mass. (C) 67, 114.
- Dyer, Wm. E., Philadelphia, Pa. (K) 213.
- Dyerville Mfg. Co., Providence, R. I. (C) 258.
- Dyson & Platt, Rockford, Ill. (W) 96.
- Eagle Cotton Mills, Lawrenceburg, Tenn. (C) 270.
- Eagle Cotton Mills Co., Madison, Ind. (C) 97.
- Eagle Dye Works, Pawtucket, R. I. (D) 256.
- Eagle Felting Mills, (Faatz-Reynolds Felting Co.) 171.
- Eagle Hosiery Mill, Gordon, Pa. (K) 238.
- Eagle Hosiery Mills (Wm. Bennett) 205.
- Eagle Knitting Mills (Danl. Shardin) 246.
- Eagle Lake Woolen Co., Jefferson, Mass. (W) 121.
- Eagle Mill (Wm. Walbert) 231.
- Eagle Mill, Eagleville, Conn. (C) 75.
- Eagle Mills (Titus, Shoard Co.) 171.
- Eagle Mills, Woonsocket, R. I. (C) 261.
- Eagle Novelty Works, New York, N. Y. (Pr) 174.
- Eagle Printing Co., Paterson, N. J. (Pr) 155.
- Eagle Silk Co., New York, N. Y. (S) 174.
- Eagle Woolen Mills, Athol, Mass. (W) 111.
- Eagle Woolen Mills (Osler & Elder) 234.
- Eagle & Phenix Mills, Columbus, Ga. (C & W) Girard, Ala. 69, 88.
- Eagleville Woolen Mills (Greenwood & Clarke) 168.
- Earncliffe Worsted Mill, Olneyville, R. I. (W) 255.
- Easley Cotton Mills, Easley, S. C. (C) 263.
- East Bay Woolen Mill (Hoxsie & Scripture) 135.
- East Blackstone Yarn Co., Blackstone, Mass. (W) 111.
- East Penn Hosiery Co., Reading, Pa. (K) 244.
- East Weymouth Wool Scouring Mill, East Weymouth, Mass. (W) 116.
- Eastern Felt and Buffing Wheel Co., Winchester, Mass. (W) 134.
- Eastern Mfg. Co., Huntsville, Ala. (C) 69.
- Easthampton Elastic Web Co., Easthampton, Mass. (C) 115.
- Eastlake Mfg. Co., Philadelphia, Pa. (C & S) 213.
- Eastman Cotton Mill Co., Eastman, Ga. (C) 88.
- Easton Cordage Works, Easton, Pa. (J) 237.
- Eastwood, J. B. & Co., Lyndell, Pa. (W) 240.
- Eastwood & Sons, Eastwood, Tenn. (W) 269.
- Eaton Rapids Wm. Mills, Eaton Rapids, Mich. (W) 137.
- Eatonton Electric Co., Eatonton, Ga. (C) 88.
- Eau Claire Linen Co., Eau Claire, Wis. (F) 281.
- Eavenson & Levering, Philadelphia, Pa. (W) 213.
- Ebensburg Woolen Mill, Ebensburg, Pa. (W) 237.
- Eclipse Mill, North Adams, Mass. (C) 127.
- Eclipse Woolen Mills, Louisville, Ky. (W) 237.
- Also Too Late for Classification List.
- Economy Hand Knit Works, New York, N. Y. (K) 174.
- Economy Hosiery Co., Philadelphia, Pa. (K) 213.
- Economy Rug Co., Davenport, Iowa (W) 99.
- Eddystone Mfg. Co., Eddystone, Pa. (Pr) 237.
- Eden Mfg. Co., Eden, Pa. (S) 237.
- Edenton Cotton Mills, Edenton, N. C. (C) 188.
- Ederer, R. J., Co., Chicago, Ill. (C) 93.
- Edgerton Mfg. Co., The C. A., Shirley, Mass. (C) 129.
- Edgefield Mfg. Co., Edgefield, S. C. (C) 263.
- Edgerton, M. D., Bristol, Conn. (K) 73.
- Edgewater Mfg. Co., Winsted, Conn. (S) 83.
- Edgewater Print Works, Philadelphia, Pa. (Pr, D & F) 213.
- Edgeworth Mill (Whittall & Thomas) 185.
- Edna Cotton Mills, Reidsville, N. C. (C) 194.
- Edon Woolen Mills (E. R. Shelline) 199.
- Edwards, James R., Est. of, Cananocht, R. I. (C) 253.
- Edwards, L. E. (Cananocht Mills) 253.
- Edward's Mfg. Co., Augusta, Me. (C) 102.
- Edwards Woolen Co., Spartansburg, Pa. (W) 248.
- Also See Too Late for Classification List.
- Efird Mfg. Co., Albermarle, N. C. (C) 184.
- Egan, K. & Co., Baltimore, Md., and Brooklyn, N. Y. (C) 197, 161.
- Eichler, A. & Co., Philadelphia, Pa. (D) 213.
- Eicke, Edward, New York, N. Y. (S) 174.
- Einstein, Henry L. (Round Brook Woolen Mills) 148.
- Elba Cotton Mill, Elba, Ala. (C) 67.
- Elberg, A., New York, N. Y. (K) 174.
- Elbow Knitting Co., Utica, N. Y. (K) 182.
- Elder, Jas., Philadelphia, Pa. (C) 213.
- Eldorado Cotton Mills, Millidgeville, N. C. (C) 192.
- Electric Dye Works, Philadelphia, Pa. (D & B) 213.
- Electric Woolen Mill, Worcester, Mass. (W) 121.
- Elgin Cotton Mills, Elgin, Ill. (C) 95.
- Elite Mfg. Co., Greenville, R. I. (C) 274.

- Elizabeth City Cotton Mills, Elizabeth City, N. C. (C) 188.
- Elizabeth City Ktg. Mills, Elizabeth City, N. C. (K) 188.
- Elizabeth Cotton Mills, Atlanta, Ga. (C) 85.
- Elizabeth Hosier Mills, Lafayette, Ga. (K) 89.
- Elizabeth Knitting Mills (Jos. W. North & Sons) 149.
- Elizabeth Knitting Mills, Berkley, Va. (K) 276.
- Elizabeth Mills, The, Charlotte, N. C. (C) 185.
- Elizabeth Mills Co., East Greenwich and Hill's Grove, R. I. (C) 253, 254.
- Elizabeth Poole Mills, Taunton, Mass. (C) 131.
- Elk Cotton Mills, Fayetteville, Tenn. (C) 269.
- Elk Knitting Mills Co., Philadelphia, Pa. (C) 213.
- Elkhorn Woolen Mills (H. Stedman) 100.
- Elkin Mfg. Co., Elkin, N. C. (K) 188.
- Ella White Cotton Mills, Uniontown, Ala. (C) 70.
- Ellerbrook, Uphaus & Co. (Glandorf Woolen Mill) 199.
- Elliot, Fred'k & Co., Waltham, Mass. (K) 132.
- Elliot Mfg. Co., Manchester, N. H. (K) 146.
- Ellis, A. B. (Cheboygan Carpet & Rug Works) 137.
- Ellis, D. W. C. & Co., Philadelphia, Pa. (C) 213.
- Ellis, D. W. & Son, Monson, Mass. (W) 125.
- Ellis, Edwin J., Troy, N. Y. (J) 182.
- Ellis, Jonathan (Rock River Woolen Mills) 281.
- Ellis, J. J. & A. D., Stafford Springs, Conn. (W) 80.
- Ellis, W. G. & Co., Philadelphia, Pa. (K) 213.
- Ellis & Co., Wortendyke, N. J. (L) 160.
- Ellison, A. S. & Co., New York, N. Y. (K) 174.
- Ellithorpe, E. L. (Luzerne Knitting Mill) 243.
- Ellrott C., Jr. & J. H. Lynch, Matteawan, N. Y. (S) 172.
- Ellsworth Woolen Mills, Ellsworth, Me. (W) 103.
- Elm Flax Mill (The A. H. Hart Co.) 174.
- Elm Grove Cotton Mills, Lincolnton, N. C. (C) 192.
- Elm Mills Woolen Co., Tilton, N. H. (W) 147.
- Elmira Blanket Co., Dryden, N. Y. (W). See Too Late Classification List.)
- Elmira Cotton Mills, Burlington, N. C. (C) 185.
- Elmira Hosiery Mills, Kernersville, N. C. (K) 191.
- Elmira Knitting Mills, Elmira, N. Y. (K) 168.
- Elmira Woolen Co., Elmira, N. Y. (W) 168. (Also see Elmira Blanket Co.)
- Elmville Woolen Co., The, Danielson, Conn. (W) 73.
- Elmwood Mills, Providence, R. I. (C) 258.
- Elston, Henry, Methuen, Mass. (W) 125.
- Elston, Wm. J., Paterson, N. J. (S) 155.
- Emerald Mills (Job Batty's Sons Co.) 203.
- Emerald Mills (Joseph Greer) 216.
- Emerald Worsted Yarn Mills (Albert Herbst & Co.) 217.
- Emmenton Woolen Mills (Flynn Bros.) 237.
- Emmers, E. & Co., Royer's Ford, Pa. (K) 216.
- Emmott Chester Worsted Spinning Co., Chester, Pa. (W) 235.
- Empire Fringe Co., New York, N. Y. (S) 174.
- Empire Knitting Mill, Cohoes, N. Y. (K) 167.
- Empire Knitting Mills (Hackett & Atwood) 181.
- Empire Knitting Mills, Chicago, Ill. (K) 93.
- Empire Knitting Mills, Brooklyn, N. Y. (K). See Too Late Classification List.
- Empire Mfg. Co., Lockport, N. Y. (C) 171.
- Empire Mill (Wm. Keegan) 219.
- Empire Silk Co., Paterson, N. J., and Carbondale, Pa. (S) 155, 234.
- Empire State Mills, Brooklyn, N. Y. (K) 164.
- Empire State Woven Label Co., West New Brighton, N. Y. (S) 184.
- Empire Woolen Co., Clayville, N. Y. (W) 166.
- Empire Worsted Mills, Jamestown, N. Y. (W) 170.
- Empire Yarn Mills, Columbiaville, N. Y. (C) 168.
- Ensley, Wm. & Bro., Philadelphia, Pa. (W) 213.
- Eudrick Woolen Mills, Great Barrington, Mass. (W) 119.
- Endurance Mills (John G. Carruth & Co.) 209.
- Enfield Knitting Mill, Enfield, N. C. (K) 188.
- Enfield Mfg. Co., Enfield, Mass. (W) 116.
- Enfield Mills, Enfield, R. I. (C) 253.
- Engle, S. F. & Jno. A. Balsbaugh (Palmyra Hosiery Mill) 243.
- Englehart, John, Guseman, W. Va. (W) 279.
- Enneper, Fred (Manhattan Braid Works) 170.
- Eno Cotton Mills, Hillsboro, N. C. (C) 190.
- Enoree Mfg. Co., Enoree, S. C. (C) 263.
- Enterprise Cotton Mills, Enterprise, Ala. (C) 67.
- Enterprise Dye Works (Mark Hough) 261.
- Enterprise Hosiery Mills, Elizabethville, Pa. (K) 237.
- Enterprise Knitting Mill, Enterprise, Miss. (K) 140.
- Enterprise Knitting Mills (A. Lautenbacher) 246.
- Enterprise Knitting Works (Jos. Roth & Co.) 200.
- Enterprise Mfg. Co., Augusta, Ga. (C) 85.
- Enterprise Mfg. Co., Coleridge, N. C. (C) 187.
- Enterprise Mills, King's Mountain, N. C. (C) 191.
- Enterprise Mills (David H. Stroud) 227.
- Enterprise Silk Co., Paterson, N. J., and Reynoldsville, Pa. (S) 155, 246.
- Enterprise Worsted Co., Millville, Pa. (W) 241.
- Ephrata Mill (Westerhoff Bros. & Napier Co.) 237.
- Epler, H. R. & Son, Reading, Pa. (K) 241.
- Erben, Harding & Co., Philadelphia, Pa. (W) 213.
- Erickson Mfg. Co., Chicago, Ill. (C) 93.
- Eric Knitting Mills, Amsterdam, N. Y. (K) 161.
- Eric Mill (Moore & Tierney) 167.
- Ernest Mill (D. G. Dery) 237.
- Erskine, Alexander, Philadelphia, Pa. (W) 213.
- Erskine, John & Co. (Norwich Silk Mfg. Co.) 178.
- Erwin Cotton Mills Co., The, Durham, N. C. (C) 188. (Also See Too Late Classification List.)
- Erwin, J. L. & Co. (Bellvue Cotton Mills) 275.
- Esrey Mfg. Co., Ltd., Chester, Pa. (W) 230.
- Essex Dye Works, Lawrence, Mass. (D) 122.
- Essex Feltling Mills (American Felt Co.) 158.
- Essex Silk Co., Paterson, N. J. (S) 155.
- Estelle Cotton Mills Co., Selma, Ala. (C) 70.
- Estes, J. H. & Sons, Fall River, Mass. (C) 116.
- Esty Hosiery Co., Laconia, N. H. (K) 145.
- Etehells, Wm. G., Pawtucket, R. I. (C) 256.
- Ethfridge, Alvin, Johnston, S. C. (C) 266.
- Ettinger, M., San Francisco, Cal. (S) 71.
- Ettick Mfg. Co., Petersburg, Va. (C) 277.
- Ettick Mill (Jno. Grieves & Co.) 96.
- Ettick Woolen Mills, Ettick, Wis. (W) 281.
- Eufaula Cotton Mills, Eufaula, Ala. (C) 67.
- Eugenia Mfg. Co., Jonesboro, N. C. (C) 190.
- Eureka Cotton Mills, Chester, S. C. (C) 263.
- Eureka Cotton Mills (Brient Bros.), 269.
- Eureka Fire Hose Co., Jersey City, N. C. (C) 151.
- Eureka Knitting Co., Norristown, Penn. (K) 242.
- Eureka Knitting Mill (Schumacher, Keller & Co.), 246.
- Eureka Knitting Mills (J. H. Pynes), 183.
- Eureka Printing Co., Athenia, N. J. (Pr.) 148.
- Eureka Ribbon Co., Pennsburg, Pa. (S) 213.
- Eureka Silk Co., Canton, Mass. (S) 113.
- Eureka Woolen Mills (F. Fisher & Sons), 200.
- Evans, Joseph P., Hamonton, N. J. (W) 151.
- Evans & Bower, Waupaca, Wis. (W) 252.
- Evans & Stonely Knitting Mills, Philadelphia, Pa. (K) 213.
- Evansville Cotton Mfg. Co., Evansville, Ind. (C) 97.
- Evansville Woolen Mill Co., Evansville, Ind. (W) 97.
- Everett Knitting Works, Lebanon, N. H. (K) 146.
- Everett Mills, Lawrence, Mass. (C) 122.
- Evergreen Ktg. Works, Brooklyn, N. Y. (K) 164.
- Everly, D. A., Pawtucket, R. I. (C) 256.
- Excelsior Beaming Mills (Geo. Butterworth), 209.
- Excelsior Finishing Works (Coulter & Lowry), 211.
- Excelsior Knitting Mill (Geo. D. Dobbins), 247.
- Excelsior Knitting Mills, Union, S. C. (C & K) 268.
- Excelsior Mfg. Co., Cuero, Texas (C) 271.
- Exchange Cotton Mfg. Co., Macon, Ga. (K) 90.
- Exeter Mfg. Co., Exeter, N. H. (C) 143.
- Exeter Mills (Brumbach Bros.) 244.
- Exposition Cotton Mills, Atlanta, Ga. (C) 85.

- Extract Wool & Merino Co., The, Chattanooga, Tenn. (W) 269.
- Faatz-Reynolds Felting Co., The, Lestershire, N. Y. (W) 171.
- Fabric Fire Hose Co., Warwick, N. Y. (C) 183.
- Fairbanks & Dorr (Granite State Mills) 145.
- Fairfield Cotton Mills, Winnsboro, S. C. (C) 268.
- Fairfield Rubber Co., Fairfield, Conn. (W) 75.
- Fairfield Woolen Mills, Fairfield, Ill. (W) 95.
- Fairhurst & Co., Patterson, N. J. (S) 155.
- Fairmont Dye Wks. (Jos Clough Sons & Co.) 209.
- Fairmont Spinning Mills (Samuel Beswick) 205.
- Fairmount Textile Co., Woonsocket, R. I. (C) 261.
- Fairmount Woolen Mills (Alden & Co.) 197.
- Faith Knitting Co., Averill Park, N. Y. (K) 163.
- Falconer Towel Co., Jamestown, N. Y. (C) 171.
- Falconer Worsted Mill, Falconer, N. Y. (W) 169.
- Falk, O. N. & Co., Philadelphia, Pa. (C) 213.
- Fall Mills Mfg. Co., Fall Mills, Tenn. (C) 269.
- Fall River Bleachery Co., Fall River, Mass. (B) & (F) 116.
- Fall River Braiding Co., Fall River, Mass. (C) 116.
- Fall River Iron Works Co., Fall River, Mass. (C) 116.
- Fall River Manufactory, Fall River, Mass. (C) 116.
- Fallkill Knitting Co., Poughkeepsie, N. Y. (K) 179.
- Falls City Jeans and Woolen Co., Louisville, Ky. (W) 101.
- Falls Co., Norwich, Conn. (C) 78.
- Falls Knitting Co., Hoosick Falls, N. Y. (K) 170.
- Falls of Schuykill Carpet Mills (J. & J. Dobson). 213.
- Falls of Schuykill Mill (J. Dobson). 213.
- Falls Yarn Mills, Woonsocket, R. I. (W) 261.
- Faribant Wrolen Mill (C. H. Klemmer & Son), 139.
- Farley, D. E., Shelburne Falls, Mass. (K) 130.
- Farley & Ruffie (Orange Knitting Co.) 118.
- Farmville Hosiery Co., Farmville, Va. (K) 276.
- Farnsworth Co., Lisbon Centre, Me. (W) 105.
- Farnum, John & Co. (Conestogo Steam Mills). 259.
- Farnum, Moses T., Wrentham, Mass. (W) 135.
- Farr Alpaca Co., Holyoke, Mass. (W) 120.
- Farrar & White, Bigstone Gap, Va. (W) 276.
- Farrall, Henry B., Philadelphia, Pa. (W) 213.
- Farwell Bleachery, Lawrence, Mass. (B) 122.
- Farwell Mills, Lisbon, Me. (C) 105.
- Farwell Worsted Mills, Middleboro, Mass. and Central Falls, R. I. (W) 125, 253.
- Fashion Knitting Co., New York, N. Y. (K) 174.
- Fashion Ktg. Mill Co., Arcade, N. Y. (K) 163.
- Fashioned Hosiery Mills, Lebanon, Pa. (K) 239.
- Faulkner, Clay (Mountain City Woolen Mills). 270.
- Faulkner, F. T., Turner, Maine. (W) 107.
- Faulkner Mfg. Co., North Billerica, Mass. (W) 128.
- Faulkner Woolen Mills, Stafford Springs, Conn. (W) 80.
- Faulkner & Colony Mfg. Co., Keene, N. H. (W) 145.
- Fawcett Bros., Brookville, Pa. (W) 234.
- Fay Stocking Co., The, Elyria, O. (K) 159.
- Fayetteville Cotton Mills, Fayetteville, N. C. (C) 188.
- Fead, John L. & Son (Lexington Wln. Mills). 138.
- Feld & Co., Philadelphia, Pa. (K) 213.
- Fenner, J. E. (Warp Knitting Mill) 130. Also See Too Late Classification List.
- Fergus Falls Woolen Mill, Fergus Falls, Minn. (W) 129.
- Ferguson, L. M., Columbus, O. (W) 198.
- Ferguson, S. B. & Co., Philadelphia, Pa. (K) 215.
- Fern Rock Woolen Mills, Philadelphia, Pa. (W) 215.
- Fessenden, Floyd, Hollisterville, Pa. (W) 239.
- Fettig, Theodore, Chicago, Ill. (K) 93.
- Fewell, R. T., Rock Hill, S. C. (C) 267.
- Fibre Spinning Co., The, Ltd., No. Wales, Pa. (C) 243.
- Fichter & Martin, Bethlehem, Pa. (S) 233.
- Fieythorn, Redcay & Co., Adamstown, Pa. (W) 221.
- Fidelity Finishing Works, Philadelphia, Pa. (F) 215.
- Fiedler, A. B. & Sons, Chicago, Ill. (S) 93.
- Fields & Hash Mfg. Co., The, Mouth of Wilson, Va. (W) 277.
- Filepl, Domenico, Paterson, N. J. (Pr) 155.
- Filer, J. A. & Co., New York, N. Y. (S) 174.
- Fincastle Woolen Mills (M. T. Ammen). 276.
- Fincher, E. A., Waleska, Ga. (C) 82.
- Fingerville Mfg. Co., Fingerville, S. C. (C) 265.
- Fink, Adam (Mercury Mills). 222.
- Fink, William, Philadelphia, Pa. (C) 215.
- Finlayson, Bousfield Spinning Co. (Grafton Flax Mill) 128.
- First Family of Shakers, Enfield, N. H. (K) 143.
- Firth Carpet Co., West Cornwall, N. Y. (W) 184.
- Firth & Foster Co., New York, N. Y., and Philadelphia, Pa. (D & F) 174, 215.
- Firwood Lace Trimming Co., Wilkesbarre, Pa. (C) 250.
- Fisher, F. & Sons, Sugar Creek, O. (W & K) 200.
- Fisher, M., New York, N. Y. (S) 174.
- Fisher Mfg. Co., Fisherville, Mass. (C) 118.
- Fisher Mfg. Co., Utica, N. Y. (K) 182.
- Fisher, Nicholas J., New Berlinville, Pa. (W) 242.
- Fisher, Richard, Gouglersville, Pa. (K) 238.
- Fisher, R. J., Athens, Tenn. (K) 268.
- Fisher & Jones, Lykens, Pa. (K) 240.
- Fiskdale Mills, Fiskdale, Mass. (C) 118.
- Fiskville Mill, Fiskville, R. I. (C) 253.
- Fitch, Sam'l Mfg. Co., Providence, R. I. (W, B) & (D) 258.
- Fitchburg Duck Mills, Fitchburg, Mass. (C) 118.
- Fitchburg Worsted Mills, Fitchburg, Mass. (W) 118.
- Fite, Edgar, New Hope, O. (W) 200.
- Fitler, Edwin H. Co., Philadelphia, Pa. (J) 215.
- Fitts Bros., West Andover, O. (W) 201.
- Flanagan, A. & Bro., Philadelphia, Pa. (W) 215.
- Flavell Bros., Philadelphia, Pa. (K) 215.
- Flavell, Geo. W. & Bro., Philadelphia, Pa. (K) 215.
- Fleck, John W., New York, N. Y. (F) 174.
- Fleetwood Mill, Fleetwood, Pa. (S) 237.
- Fleischer, Ernest, Milwaukee, Wis. (K) 281.
- Fleischer, Wm., Milwaukee, Wis. (K) 281.
- Fleischman, Fredk. (Carroll Mfg. Co.) 166.
- Fleisher, S. B. & B. W., Philadelphia, Pa. (W) 215.
- Fleming, Chas. H., Philadelphia, Pa. (D) 215.
- Fleming, John R., Forksville, Pa. (W) 238.
- Flesch, C., New York, N. Y. (K) 174.
- Fletcher Mfg. Co., Providence, R. I. (C) 258.
- Flinders, Wm., Brooklyn, N. Y. (K) 164.
- Fling's, Joseph Sons, Philadelphia, Pa. (W) 215.
- Flint Mill, Fall River, Mass. (C) 117.
- Flint Woolen Mills Co., Flint, Mich. (W) 137.
- Flocker, John & Co., Allegheny, Pa. (J) 231.
- Florence Mills, Forest City, N. C. (C) 188.
- Florence Mills (Josephs & Herbst). 219.
- Florence Thread Co., Florence, N. J. (C) 149.
- Flossette Mfg. Co., Pawtucket, R. I. (S) 256.
- Flower City Dye Works, Rochester, N. Y. (D) 180.
- Flynn Bros., Emlenton, Pa. (W) 237.
- Fogle & Killin, Paterson, N. J. (S) 155.
- Follwell Bro. & Co., Philadelphia, Pa. (W) 215.
- Fonda, A. V., Gloversville, N. Y. (K) 169.
- Fooks, Isaac N., Georgetown, Del. (K) 83.
- Foot Knitting Co., The, New York, N. Y. (K) 174.
- Foot, C. F., Ipava and Rushville, Ill. (W) 95, 96.
- Foot, J. & Son, Rushville, Ill. (W) 96.
- Forbes Wool Co., The, Trinidad, Col. (W) 72.
- Ford Mfg. Co., Waterford, N. Y. (K) 183.
- Ford, R. J. & Co., Boston, Mass. (K) 112.
- Ford, W. & R., Philadelphia, Pa. (J) 215.
- Forest City Knitting Co., Rockport, Ill. (K) 95.
- Forest Mills (Mullen, T. F. & Co.) 80.
- Forest Mills Co., Bridgton, Me. (W) 102.
- Fork Shoals Cotton Mill Co., Fork Shoals, S. C. (C) 265.
- Formanns, Stumpf & Sharpe, Paterson, N. J. (D) 155.
- Forrest, John, Philadelphia, Pa. (Pr & D) 215.
- Forrestdale Mfg. Co., Forrestdale, R. I. (C) 253.
- Forry, I. W. & Son, Duncannon and Shamokin, Pa. (K) 237, 247.
- Forsyth Mfg. Co., Forsyth, Ga. (C) 88.
- Fort Mill Mfg. Co., Fort Mill, S. C. (C) 265.

- Fort Plain Hosiery Co., Fort Plain, N. Y. (K).  
See Too Late Classification List.
- Fort Plain Knitting Co., Fort Plain, N. Y. (K) 169
- Fort Schuyler Knitting Co., Utica, N. Y. (K) 182.
- Fort Starwix Knitting Co., Rome, N. Y. (K) 180.
- Fort Valley Knitting Mills, Fort Valley, Ga. (K) 88.
- Fosston Woolen Co., Fosston, Minn. (W) 139.
- Foster, J. R. & Sons, Philadelphia, Pa. (D & F) 215.
- Foster, T. & Son, Cumberland, Md. (D) 108.
- Foster, W. A., Philadelphia, Pa. (F) 215.
- Foster & Taylor (Newburgh Woolen Mills). 173.
- Foulds, W. C. (Dragon Dye Works). 213.
- Foulk, R. T., Philadelphia, Pa. (W) 215.
- Fountain Cotton Mills, Tarboro, N. C. (C) 195.
- Fountain Inn Mfg. Co., Fountain Inn, S. C. (C) 265.
- Foutz, E. C. & Bro., West Alexandria, O. (W) 200.
- Fowler Net & Twine Co., Philadelphia, Pa. (C) 215.
- Fox, Henry & Co., Urbana, Ohio. (W) 200.
- Fox River Valley Knitting Co., Appleton, Wis. (K) 280. (See also too late for classification list.)
- Fox's, Samuel, Sons, La Porte, Ind. (W) 97.
- France, David, Prospect, N. Y. (K). See Too Late Classification List.
- Francis, Dr. L. K. & Son, Boyertown, Pa. (K) 234.
- Frank, R., New York, N. Y. (K) 174.
- Frank & Dugan, Paterson, N. J. (S) 155.
- Frankford Carpet Mills. (W. & R. Ford). 215.
- Frankford Co-operative Mfg. Co., Philadelphia, Pa. (C) 215.
- Frankford Hosiery Co., Philadelphia, Pa. (K) 215.
- Frankford Waste Co., Philadelphia, Pa. (C & W) 215.
- Franklin Bleaching & Finishing Works, Ltd., Philadelphia, Pa. (B1 & F) 215.
- Franklin Carpet Mills (Robt. Carson). 209.
- Franklin Cotton Mill, Cincinnati, Ohio. (C) 198.
- Franklin Hosiery Co., Philadelphia, Pa. (K) 215.
- Franklin Knitting Mills, The, Orwigsburg, Pa. (K) 213.
- Franklin Mill (Am. Felt Co.) 119.
- Franklin Mills, Franklin Falls, N. H. (W) 143.
- Franklin Mills, Pittston, Pa. (C) 243.
- Franklin Mills, Greer Depot, S. C. (C) 265.
- Franklin Woolen Mills Co., Franklin, Ky. (W) 100.
- Franklin Yarn Mfg. Co., Franklin, Mass. (W) 119.
- Franklin Yarn Mills, (Joseph Randall & Bro.) 221.
- Franklinville Duck Mills (Mt. Vernon-Woodberry Cotton Duck Co.) 108.
- Franklinville Dye Works Co., Ltd., Philadelphia, Pa. (D) 215.
- Franklinville Mfg. Co., Franklinville, N. C. (C) 189.
- Franksville Tow Co., Franksville, Wis. (F1) 251.
- Franz, John, Cleveland, Ohio. (S) 198.
- Freedom Mills (Wm. Linn, Jr.) 193.
- Freeland Mfg. Co., Philadelphia, Pa. (W) 215.
- Freeland Mills (A. Planagan & Bro.) 215.
- Freeland Silk Mill Co., Freeland, Pa. (S) 238.
- Fremont Knitting Factory, Rexburg, Idaho. (K) 92.
- French Hair Cloth Co., The, Pawtucket, R. I. (C) 256.
- French-Hickman Flax Co., Niagara Falls, N. Y. (F1) 178.
- French, Hugh & Son, Philadelphia, Pa. (W) 215.
- French Lumbering Co. (Chippewa Falls Woolen Mill). 280.
- French River Textile Co., Mechanicsville, Conn. (W) 78.
- French & Ward, Stoughton, Mass. (W & K) 131.
- Fretz, Samuel S. Co., Philadelphia, Pa. (S) 215.
- Freyberg Bros., New York, N. Y. (S) 174.
- Froylinghuyssen, The. (Index Knitting Mills) 179.
- Fricke, J. E. Co., Hulmeville, Pa. (C) 239.
- Fricke, Herman & Co., Brooklyn, N. Y. (S) 164.
- Friedberger Mfg. Co., Philadelphia, Pa. (C. W & S) 215.
- Friedlander, Brady & Co., Chicago, Ill. (K) 93.
- Friedlander, M., Cleveland, O. (K) 198.
- Friedlander, Morris, Milwaukee, Wis. (K) 281.
- Friedman, H. & Co., Cleveland, Ohio. (K) 198.
- Friedman, L. & P. Miller (Art Knitting Mill), 203.
- Friedman & Rosenfeld (Progressive Ktg. Mills). 137.
- Fries-Breslin Co., Camden, N. J. (W) 148.
- Fries, F. & H. (Arista Cotton Mills). 196.
- Fries, F. H., Woolen Mills, Winston-Salem, N. C. (W) 196.
- Fries-Harley Co., Gloucester City, N. J. (W) 149.
- Fritz & Krause, Pottstown, Pa. (K) 244.
- Frogmore Mill (Isaac Walker). 228.
- Fromm, S., Brooklyn, N. Y. (K) 164.
- Fromuth, C., Philadelphia, Pa. (W) 215.
- Frost, Chas. E., Paterson, N. J. (S) 155.
- Frost & Van Riper, Paterson, N. J. and Pittston, Pa. (S) 155, 243.
- Fruch, John (Mnneapolis Embroidery Works). 139.
- Frysinger, Frank, York, Pa. (W) 250.
- Fuchs Silk Co., Paterson, N. J. (S) 155.
- Fuld & Hatch, Albany, N. Y. (K) 161.
- Fulmer, D. A., Titusville, Pa. (K) 249.
- Fulton Bag & Cotton Mills, Atlanta, Ga. and New York, N. Y. (C) 85, 174.
- Fulton County Silk Mills, Gloversville, N. Y. (S & K) 169.
- Fulton, D. & Co., Paterson, N. J. (W) 155.
- Fulton Worsteds Mills, Fulton, N. Y. (W) 168.
- Fulton & Smith, Haledon, N. J. (S) 151.
- Funk, Harvey E., Huntingdon, Pa. (K) 239.
- Gabriel's, H. Sons, Allentown, Pa. (K, D & B1) 231.
- Gaede, Robert, Paterson, N. J. (D) 155.
- Gaenzle & Leippe (Reading Ktg. Mills). 245.
- Gaffney Carpet Mfg. Co., Gaffney, S. C. (W) 265.
- Gaffney Mfg. Co., Gaffney, S. C. (C) 265.
- Gainesville Cotton Mills, Gainesville, Ga. (C) 89.
- Galashan, John, Philadelphia, Pa. (C) 215.
- Galbraith, M., Estate of, Philadelphia, Pa. (W) 215.
- Galeton Cotton Mills, West Point, Ga. (C) 92.
- Galesville Woolen Mills, Galesville, Wis. (W & K) 281.
- Galey & Lord Mfg. Co., Chester, Pa. (C) 235.
- Gallagher, D. J., Mfg. Co., Chicago, Ill. (C) 93.
- Gallan, H., Brooklyn, N. Y. (K) 164.
- Galveston Bagging & Cordage Co., Galveston, Tex. (J) 272.
- Galveston City Cotton Mills, Galveston, Tex. (C) 272.
- Galveston Rope Co., Galveston, Tex. (J) 272.
- Gambrell, M., Harve de Grace, Md. (C) 108.
- Gambrell & Melville Mills (M. Gambrell), 108.
- Gantner & Matern Co., San Francisco, Cal. (K) 71.
- Garden City Knitting Works, Jacksonville, Ill. (K) 95.
- Gardiner Shoddy Mills, Gardiner, Me. (W) 103.
- Gardiner & Warring, Amsterdam, N. Y. (K) 161.
- Gardner, John & Son, Philadelphia, Pa. (W) 215.
- Gardner, W. A., Philadelphia, Pa. (W) 215.
- Garfield Woolen Co., Garfield, N. J. (W) 149.
- Garner, Allen (Limerick Mills). 105.
- Garner & Co., Pleasant Valley, N. Y. (C) 179.
- Garner & Co., Reading, Pa. (C) 244.
- Garnett Bros., Clifton Heights, Pa. (W) 235.
- Garsed, Jeha, Hulmeville, Pa. (C) 239.
- Gary, J. S. & Sons, Alberton, Md. (C) 107.
- Gaston Mfg. Co., Cherryville, N. C. (C) 187.
- Gastonia Cotton Mfg. Co., Gastonia, N. C. (C) 189.
- Gate City Cotton Mills, Atlanta, Ga. (C) 85.
- Gate City Hosiery Mills, Denison, Texas. (K) 272.
- Gates, Israel, Canochet, R. I. (C & S) 253.
- Gauschy Silk Dyeing Co., The, Paterson, N. J. (D) 155.
- Gaver, T. F., Hillsboro, Va. (W) 277.
- Gavin, Wm. E., New York, N. Y. (S) 174.
- Gay Bros. Co., Cavendish, Vt. (W) 275.
- Gay, Henry C., Barton, Vt. (W) 273.
- Gay's, John Sons (Inc.) Philadelphia, Pa. (W) 215.
- Gaylesville Cotton Mill Co., Gaylesville, Ala. (C) 67.
- Geagley, J. J. (Home Woolen Mills). 269.
- Gebauer, Julius A., Philadelphia, Pa. (W) 216.

- Geering, Emil, Paterson, N. J. (D) 155.  
 Geier, August, Cincinnati, Ohio. (K) 198.  
 Geiger & Groff, Reading, Pa. (K) 244.  
 Gelderman, F. H., Paterson, N. J. (S) 155.  
 Gem Hammock & Fly Net Co., Milwaukee, Wis. (C) 281.  
 Gem Knitting Mills, Columbia, Pa. (K) 235.  
 Gem Knitting Mills (Geiger & Groff). 244.  
 Genesee Woolen Mill (James Proctor). 281.  
 Genet, John J. & Son, Leopold, Ind. (W) 97.  
 Geneva Knitting Mills, Philadelphia, Pa. (C) 216.  
 Geneva Mill, Providence, R. I. (W) 258.  
 Genevieve Novelty Co., Paterson, N. J. (S) 155.  
 George's River Mills, Warren, Maine. (W) 107.  
 Georgetown Hosiery Co., Wilmington, Del. (K) 84.  
 Georgetown Hosiery Mill, (C. M. Romberger). 238.  
 Georgia Mfg. Co., Columbus, Ga. (K) 88.  
 Georgia Mfg. Co., Gainesville, Ga. (C) 88.  
 Georgia Mfg. Co., White Hall, Ga. (C) 92.  
 Georgia School of Technology, Atlanta, Ga. (C & W) 85.  
 Georgia Underwear Co., Barnesville, Ga. (K) 86.  
 Gera Mills, Passaic, N. J. (W) 153.  
 Gerhart, J. H., Denver, Pa. (K) 236.  
 Gerlach, A. & Co., College Point, N. Y. (D & F) 168.  
 German-American Hosiery Co., Philadelphia, Pa. (K) 216.  
 German Artistic Weaving Co., Pompton Lakes, N. J. (S) 158.  
 German Knitting Mills (Z. & B. Schapiro). 165.  
 Germania Dye Works (Max Sarfert). 225.  
 Germania Knitting Works (Wm. Reichman). 177.  
 Germania Mills, Holyoke, Mass. (W) 120.  
 Germantown Cordage Works (Jas. Elder). 213.  
 Germantown Lace Works, Philadelphia, Pa. (C) 216.  
 Germantown Spinning Co., Philadelphia, Pa. (C) 216.  
 Germantown Yarn Mill (Joseph Fling's Sons). 215.  
 Gernshyng, Henry & Bro., Brooklyn, N. Y. (K) 164.  
 Gerstenschlag, Jacob, New York, N. Y. (S) 174.  
 Getty & Spratt, Philadelphia, Pa. (W) 216.  
 Giannetti, Mrs. M. L., Pompton Lakes, N. J. (S) 158.  
 Gibboney, A. R. & Co., Reedsville, Pa. (W) 216.  
 Gibboney, B. A., McAlevy's Fort, Pa. (W) 240.  
 Gibson, E. G., East Brookfield, Mass. (W) 115.  
 Gibson Mfg. Co., Concord, N. C. (C) 187.  
 Gifford, J. T. & Sons, Lee, Maine. (W) 103. (also see too late Classification list.)  
 Gilbert, Geo. H. Mfg. Co., Ware, Mass. (W) 132.  
 Gilbert Ktg. Co., Little Falls, N. Y. (K) 171.  
 Gilbert, Wm. A. & Co., Stroudsburg, Pa. (S) 248.  
 Gill, Thos. & Son, Philadelphia, Pa. (C) 216.  
 Gilman's J. P. Son (Bradford Hat Factory) 113.  
 Gilman's Mills, Belmont, N. H. (K) 113.  
 Gilmour, R. & A. J., Philadelphia, Pa. (K) 216.  
 Gilsun Woolen Mfg. Co., Gilsun, N. H. (W) 145.  
 Ginther Bros., Pottsville, Pa. (K) 244.  
 Girard Carpet Works (Wm. M. Sharkey). 226.  
 Girard Cotton Mills, Girard, Ala. (C) 69.  
 Girard Worsted Mill (E. K. Bready). 205.  
 Givernaud Bros., Hackensack and West Hoboken, N. J., and Allentown, Pa. (S) 151, 160, 231.  
 Gladding, E. F. & Co., South Otselic, N. Y. (C) 181.  
 Glandorf Woolen Mill, Glandorf, O. (W) 199.  
 Glasgo Yarn Mills Co., Glasgo, Conn. (C) 75.  
 Glasgow Mfg. Co., South Hadley Falls, Mass. (C) 131.  
 Glasgow Mill, Philadelphia, Pa. (C) 216.  
 Glastonbury Knitting Co., Addison and Manchester Green, Conn. (K) 72, 76.  
 Glazier, Franklin & Son, So. Glastonbury, Conn. (W) 80.  
 Gleason, A. D., Gleasondale, Mass. (W) 119.  
 Glen Mills, Oakdale, Mass. (W) 128.  
 Glen Riddle Mills, Glen Riddle, Pa. (W) 238.  
 Glen Rock Mills (Morris & Ott). 222.  
 Glen Woolen Co., No. Oxford, Mass. (W) 128.  
 Glen Worsted Mills, Harrisville, R. I. (W) 254.  
 Glenark Knitting Co., Woonsocket, R. I. (K) 261.  
 Glencoe Cotton Mills, Burlington, N. C. (C) 185.  
 Glendale Elastic Fabrics Co., Easthampton, Mass. (C) 115.  
 Glendale Woolen Mill, Glendale, R. I. (W) 254.  
 Glendora Knitting Co., New Haven, Conn. (K) 77.  
 Gleniffer Mills (Wm. Paton, Ltd.) 128.  
 Glenlyon Dye Works, Providence and Saylesville, R. I. (B1, D & Pr) 258, 259.  
 Glenn, Isalah, Avalanche, Wis. (W & K) 280.  
 Glenn-Lowry Mfg. Co., Whitmires, S. C. (C) 268.  
 Glenside Woolen Mills, Skaneateles Falls, N. Y. (W) 181.  
 Glenwood Cotton Mill, Easley, S. C. (C) 263. (Also see Too Late Classification List.)  
 Glenwood Mills (Moses T. Farnum). 135.  
 Glenwood Works, Medford, Mass. (D, B1 & F). 124.  
 Globe Carpet Mills (Thos. Huston & Co.) 218.  
 Globe Cloth Examining, Sponging & Refinishing Co., New York, N. Y. (F) 174.  
 Globe Cotton Mills, Augusta, Ga. (C) 86.  
 Globe Dye Works, Little Falls, N. J. (D & B1) 152.  
 Globe Dye & Bleach Works (R. Greenwood & Baul) 216.  
 Globe Finishing Works (W. A. Foster) 215.  
 Globe Hat Co., Mohn's Store, Pa. (W) 241.  
 Globe Knitting Mill (F. W. Kavanaugh Mfg. Co.) 167.  
 Globe Knitting Mill (Richard Lorenz) 93.  
 Globe Knitting Mills (Wm. Wolfe & Son) 247.  
 Globe Knitting Works, Grand Rapids, Mich. (K) 137.  
 Globe Mills (Taylor & Scott) 228.  
 Globe Silk Works, New Haven, Conn. (S) 77.  
 Globe Woolen Co., Utica, N. Y. (W) 182.  
 Globe Worsted Mills, Lawrence, Mass. (W) 122.  
 Globe Yarn Mills, Fall River, Mass. (C) 117.  
 Gloucester Cotton Mills Co., Gloucester City, N. J. (C) 149.  
 Gloucester Mfg. Co., Gloucester City, N. J. (Pr) 149.  
 Gloucester Net & Twine Co., Gloucester, Mass. (C) 119.  
 Glover Mfg. Co., Juliette, Ga. (C) 89.  
 Gloversville Felt Co., Gloversville, N. Y. (W) 169.  
 Gloversville Knitting Co., Gloversville, and Oneonta, N. Y. (K) 169, 178.  
 Gloversville Silk Mills, Gloversville, N. Y. (S) 169.  
 Gloversville Textile Co., Gloversville, N. Y. (S) 169.  
 Godley, Frank, Springfield, Ill. (W) 96.  
 Godshalk, E. H. Co., The, Philadelphia, Pa. (C & K) 216.  
 Goetz Silk Mfg. Co., Holyoke, Mass. (S) 120.  
 Goff, D. & Sons, Pawtucket, R. I. (C & W) 256.  
 Gold Crown Hosiery Mills, Zircornia, N. C. (K) 197.  
 Gold Medal Braid Co., Attleboro, Mass. (C) 137 & S) 111.  
 Gold Medal Twine Mills (Am. Net & Twine Co.) 67.  
 Goldberg & Co., I. (New England Dusting Mill). See Too Late Classification List.  
 Golden Belt Mfg. Co., Durham, N. C. (C) 188.  
 Golden Fleece Mills (Auburn Blanket Co.) 163.  
 Golden Pledge Woolen Mill Co., Pillsbury, Minn. (W & K) 140.  
 Golden Gate Knitting Mill (Gantner & Mattern Co.) 71.  
 Golden Gate Woolen Mfg. Co., San Francisco, Cal. (W) 72.  
 Golden Rod Mill, Wales, Mass. (W) 132.  
 Golden, Thomas, Paterson, N. J. (S) 155.  
 Goldman, Chas., Paterson, N. J. (S) 155.  
 Goldville Mfg. Co., Goldville, S. C. (C) 265.  
 Gonic Mfg. Co., Gonic, N. H. (W) 145.  
 Gonzales Cotton Mills, The, Gonzales, Texas. (C) 272.  
 Good, John, Cordage & Mach. Co., Brooklyn, N. Y. (D) 164.  
 Good, John & Jennings Patent Mach. Cordage Co., Brooklyn, N. Y. (D) 164.  
 Good, Martin, High Spire, Pa. (W & K) 239.  
 Goodall Worsted Co., Sanford, Maine. (W) 106.  
 Goodman, Loeb & Co., Philadelphia, Pa. (S) 215.  
 Goodspeed, F. J. (Wilton Woolen Mills) 107.  
 Goodwin, R. E. (Bemis Mills) 111.  
 Goodwin, R. L., Atlanta, Ga. (C) 85.  
 Gordon Bros., Hazardville, Conn. (W) 75.  
 Gordon Mfg. Co., Boston, Mass. (C) 112.  
 Gordon, Wm. M. (Grayson Woolen Mills) 277.

- Gorman, T. C., Philadelphia, Pa. (C) 216.  
 Gorse, F. W., Highlandville, Mass. (K) 120.  
 Gorse, Wm. & Co., Highlandville, Mass. (K) 120.  
 Goshen Woolen Mfg. Co., Goshen, Ind. (W) 97.  
 Gosner, W. H. (Lehigh Steam Bleachery) 248.  
 Goss Bros., Fall River, Mass. (C) 117.  
 Gotham Knitting Mills (S. D. Bausher) 238.  
 Gotham Silk Mills (M. C. Migel & Co.) 163.  
 Gould, C. & J., Philadelphia, and So. Bethlehem, Pa. (K) 216, 248.  
 Gould, H. A. (Pavonia Knitting Mills) 151.  
 Gould Mfg. Co., Shirley, Mass. (W) 130.  
 Gould, O. L., Bangor, Maine, (W) 102.  
 Gould Wire Cord Co., Malden, Mass. (C) 124.  
 Graef Hat Band Mfg. Co., Paterson, N. J. (S) 155.  
 Graff, Peter & Co., Worthington, Pa. (W) 230.  
 Grafton Flax Mill, North Grafton, Mass. (FD) 128.  
 Graham, Clark & Co., Adams, Mass. (W) 109.  
 Graham, G. W. Co., Paterson, N. J. (S) 155.  
 Graham, H. H. & T. H., Pinewood, Tenn. (C) 271.  
 Grahambton Mfg. Co., Grahambton, Ky. (C) 100.  
 Grear Cotton Mills, Columbia, S. C. (C) 263.  
 Grand Forks Wln. Mills, Grand Forks, N. D. (W) 197.  
 Grand Rapids Felt Boot Co., Grand Rapids, Mich. (W & K) 137.  
 Grand Rapids Knitting Co., Grand Rapids, Mich. (K) 138.  
 Grandjean, A. N., New York, N. Y. (S) 174.  
 Grange, Wm. G., Philadelphia, Pa. (C) 216.  
 Granite Falls Mfg. Co., Granite Falls, N. C. (C) 189.  
 Granite Hosiery Mills (Busiel, J. W. & Co.) 145.  
 Granite Linen Co., Paterson, N. J. (D) 155. (see also too late classification 118).  
 Granite Mfg. Co., Haw River, N. C. (C) 190.  
 Granite Mills, Fall River, Mass. (C) 117.  
 Granite Mills (Wm. Moore Ktg. Co.) 167.  
 Granite Mills (A. L. Sayles & Sons) 255.  
 Granite State Electrical Works, Lisbon, N. H. (S) 146.  
 Granite State Mills, Guild, N. H. (W) 145.  
 Graniteville Mfg. Co., Graniteville, S. C. (C) 265.  
 Grant, Henry & Son, Philadelphia, Pa. (W) 216.  
 Grant Mills (Hebron Mfg. Co.) 258.  
 Grant Yarn Co., Fitchburg, Mass. (C) 118.  
 Grantville Hosiery Mills, Grantville, Ga. (K) 89.  
 Graves, Frank, Highlandville, Mass. (W) 120.  
 Graw & Lehmann, New York, N. Y. (S) 174.  
 Gray, S. & Co., The, Walpole, Mass. (Bl & D) 132.  
 Gray, T. H. & Co., Hyde Park, Mass. (W) 121.  
 Grayson, Geo., Darby, Pa. (W) 236.  
 Grayson Woolen Mills, Old Town, Va. (W) 277.  
 Great Falls Bleachery & Dye Works, Somersworth, N. H. (Bl & D) 147.  
 Great Falls Cotton Mills Co., Falls City and McMinnville, Tenn. (C) 269, 270.  
 Great Falls Mfg. Co., Rockingham, N. C. (C) 194.  
 Great Falls Mfg. Co., Somersworth, N. H. (C) 147.  
 Great Falls Woolen Co., Somersworth, N. H. (W) 147.  
 Great Western Knitting Co., Milwaukee, Wis. (K) 281.  
 Greaves Bros., Philadelphia, Pa. (W.) 216.  
 Greaves, Thomas, Philadelphia, Pa. (K) 216.  
 Greaves, Thos. W., Philadelphia, Pa. (K) 216.  
 Greaves & Hutchinson (Crown Worsted Mills) 258.  
 Green, A. & Co., Baltimore, Md. (C) 107.  
 Green, C., New York, N. Y. (S) 174.  
 Green Island Knitting Mills, Green Island, N. Y. (K) 169.  
 Green, J. C., Worcester, Mass. (C) 134.  
 Green Knitting Co., Amsterdam, N. Y. (K) 161.  
 Green Mountain Braiding Co., Pawtucket, R. I. (C) 256.  
 Green, M. J., Paterson, N. J. (S) 155.  
 Green River Woolen Mills, Phill., Ky. (W) 101.  
 Green, Wm. H., Pennrun, Penn. (W) 243.  
 Greenberg & Laeger, New York, N. Y. (S) 174.  
 Greene Bros. (Cazenovia Woolen & Felt Co.) 156.  
 Greene & Daniels Mfg. Co., Pawtucket, R. I. (C) 256.  
 Greenfield, J. H. & Co., Duquoin, Ill. (K) 95.  
 Greenfield, J. M., Kernersville, N. C. (K) 131.  
 Greenland Coir Mfg. Co., Brooklyn, N. Y. (D) 164.  
 Greenville Cotton Mills, Greenville, N. C. (C) 190.  
 Greenville Knitting Mills, Greenville, N. C. (K) 190.  
 Greenville Woolen Mills, Greenville, R. I. (W) 254.  
 Greenwich Bleachery, The, East Greenwich, R. I. (Bl & F) 253.  
 Greenwood, Chas. A. & Co., Corinna, Maine (W) 103.  
 Greenwood Cotton Mills, Greenwood, S. C. (C) 265.  
 Greenwood, John, Philadelphia, Pa. (D) 216.  
 Greenwood, R. & Bault, Philadelphia, Pa. (D) 216.  
 Greenwood, Saml, Woolen Mills, Coatsville, Pa. (W) 266.  
 Greenwood & Clarke, East Salem, N. Y. (W) 168.  
 Greenwood & Payton Co., Lowell, Mass. (W & K) 123.  
 Greenwoods Div. (Mt. Vernon-Woodberry Cotton Duck Co.), New Hartford, Conn. (C) 77.  
 Greer, Benj. W., Philadelphia, Pa. (C & W) 216.  
 Greer, David, Philadelphia, Pa. (W) 216.  
 Greer, Joseph, Philadelphia, Pa. (W) 216.  
 Gregory, Wm., Paterson, N. J. (S) 155.  
 Grendel Mills, Greenwood, S. C. (C) 265.  
 Greylock Mills, North Adams, Mass. (C) 127.  
 Greystone Mills (James Campbell) 253.  
 Grieves, John & Co., Lacon, Ill. (W) 96.  
 Griffin, D. J., Chattanooga, Tenn. (C) 269.  
 Griffin Knitting Mills, Griffin, Ga. (K) 89.  
 Griffin Mfg. Co., Griffin, Ga. (C) 89.  
 Griffith, John (Brookland Mills), 278.  
 Griffin Company, Philadelphia, Pa. (W) 216.  
 Grimshaw Bros., Paterson, N. J., and Reading, Pa. (S) 156, 245.  
 Grinnell Mfg. Corp., New Bedford, Mass. (C) 126.  
 Griswold Cotton Mill Co., The, Voluntown, Conn. (C) 81.  
 Griswold Worsted Co., Ltd., Darby, Pa. (W) 236.  
 Griswoldville Mfg. Co., Griswoldville, Mass. (C) 119.  
 Groat, Charles Co., Greenwich, N. Y. (K) 169.  
 Grossenbach & Van Nostitz, New York, N. Y. (S) 174.  
 Grosvenor Woolen Co., Holyoke and Palmer, Mass. (W) 120, 129.  
 Grosvenordale Co., No. Grosvenordale, Conn. (C) 78.  
 Graveland Mills (Voasey & Hale) 131.  
 Grover, John D. & Son, Philadelphia, Pa. (W) 216.  
 Grover, Wm. F. & Co., Philadelphia, Pa. (K) 216.  
 Groveville Mills (Morris & Co.), 160.  
 Grube, Geo. W., So. Bethlehem, Pa. (S) 248.  
 Grundy, W. H. & Co., Bristol, Pa. (W) 234.  
 Guenther, Geo. G., Reading, Pa. (K) 245.  
 Guenther, Paul, Dover, N. J. (K) 149.  
 Guerin Spinning Co., Woonsocket, R. I. (W) 261.  
 Guile & Waterhouse (Earncliffe Wst. Mill) 255.  
 Gulf Bag Co., New Orleans, La. (J) 102.  
 Gulf Woolen Mills (Geo. McFarland Co.) 249.  
 Gumbinner, Paul Co., Emaus, Pa. (S) 237.  
 Gunner's Run Dye & Finishing Works (John Laferty & Bro.) 220.  
 Gutsche, R., (National Knitting Works) 222.  
 Guyardotte Woolen & Knitting Mills (V. & B. Stewart) 279.  
 Guzman, J. H., Iowa City, Iowa (W) 99.  
 Gwyn-Harper Mfg. Co., Patterson, N. C. (C & W) 183.  
 Hackenberg, Wm. B. & Co., Philadelphia, Pa. (S) 216.  
 Hackett & Atwood, Stittville, N. Y. (K) 181.  
 Hadley Co., Holyoke, Mass. (C) 120.  
 Hadley, People's Mfg. Co., Siler City, N. C. (C) 195.  
 Haenichen Bros., Paterson, N. J. (S) 156.  
 Hafflinger, Gustave, Maspeth, N. Y. (J) 172.  
 Haigh, J. C. & Co., Philadelphia, Pa. (F) 216.  
 Haigh, J. F., Le Raysville, Pa. (W) 240.  
 Haigh, S. & Sons, Humansville, Mo. (W) 141.  
 Haight, Louis P., Muskegon, Mich. (K) 128.  
 Haile & Frost Mfg. Co., The, Hinsdale, N. H. (W) 145.  
 Hair, J. Ulysses, Wernersville, Pa. (K) 249.



- Haines, I. F., Lower Cabot, Vt. (W) 275.  
Hainsworth, T., Neosho, Mo. (W & K) 142.  
Halcyon Knitting Mills, So. Bethlehem, Pa. (K) 248.  
Halcy, Robt. A., Paterson, N. J. (S) 156.  
Halford, Joseph & Sons, Philadelphia, Pa. (K) 216  
Hall Bros., Norwich and Preston, Conn., 78, 79.  
Hall Carpet Co., James, The, Philadelphia, Pa., (W) 216.  
Hall, Chas. H., New York, N. Y. (K) 174.  
Hall, E. H. & Son (No. Windham Mills), 78.  
Hall, Gardiner, Jr. & Co., So. Willington, Conn. (C) 80.  
Hall, Harriet S., Jersey City, N. J. (S) 151.  
Hall, Henry, Highland Mills, N. Y. (S & J), 169.  
Hall, H. W., Emporia, Va. (K) (See Too Late Classification List.)  
Hall, James, Conshohocken, Pa. (W), 236.  
Hall, Lincoln & Co. (Chace Mill and Williams Duck Mill), 76, 77.  
Hall, L. C., Jr., & Co., Philadelphia, Pa. (K) 216.  
Hall Mfg. Co., W. A., St. Louis, Mo. (K), 142.  
Hall, Stephen, McLeansboro, Ill. (W), 96.  
Hall, W. & Co., Lansdown, Pa. (W), 239.  
Hall & Co. (Jamestown Worsted Mills and Jamestown Woolen Mills), 171.  
Hallville Mills (Hall Bros.), 79.  
Haltman, M. L., Philadelphia, Pa. (C), 216.  
Haltom's, Thos., Sons, Philadelphia, Pa. (C) 216.  
Haman, F. D., Philadelphia, Pa. (W), 217.  
Hamberger Knitting Mills, Lancaster, O. (K), 199.  
Hamburg Bleach Works, Hamburg, Pa. (B), 238.  
Hamburg Cotton Factory Asso., Hamburg, Ark. (C), 71.  
Hamburg Cotton Mills, Mt. Airy, N. C. (C), 193.  
Hamburg Knitting Mills, Hamburg, Pa. (K), 238.  
Hamburger Cotton Mills, Columbus, Ga. (C), 88.  
Hamden Bleachery, Chicopee Falls, Mass. (B), 114.  
Hamill & Co., Philadelphia, Pa. (W), 217.  
Hamilton, John, Philadelphia, Pa. (W), 217.  
Hamilton Mfg. Co., Lowell, Mass. (C & Pr), 123.  
Hamilton Web Co., Hamilton, R. I. (C), 254.  
Hamilton Woolen Co., Amesbury and Globe Village, Mass. (C & W), 111, 119.  
Hamilton & Bowles, Paterson, N. J. (S), 156.  
Hamlet Textile Co., Woonsocket, R. I. (C), 261.  
Hamlin, W. K., Waterford, Me. (W), 107.  
Hammond Cotton Mill Co., Ltd., Hammond, La. (C), 101.  
Hammond, Knowlton & Co., Putnam, Conn. (S), 79.  
Hampten Knitting Mills Co., Reading, Pa. (K), 245.  
Hampten Mills Co., Hampden, Mass. (W), 120.  
Hampten Woolen Mills (Thos. H. Wilson), 230.  
Hampton Company, Easthampton, Mass. (D), 115.  
Hampton Cotton Mills, Hampton, Ga. (C), 89.  
Hand, John & Sons, Wilmington, Del., and Paterson, N. J. (S) 84, 156.  
Handley, W. A. Mfg. Co., Roanoke, Ala. (C), 69.  
Handy, Mrs. S. J. (Eagle Woolen Mills), 111.  
Hanes, J. W., Winston-Salem, N. C. (K) 196.  
Hanifen, John E. & Co., Philadelphia, Pa. (K), 217.  
Hanks, P. G., Gurleyville, Conn. (S), 75.  
Hanna, R. H. (Anchor Woolen Mills), 270.  
Hannigan, J. P., Glen Rock, Pa. (W), 238.  
Hanover Mfg. Co., Ltd., Bethlehem, Pa. (K), 233.  
Hanover Silk Co., Hanover, Pa. (S), 238.  
Hanover Woolen Mfg. Co., Hanover, Ill. (W), 95.  
Hanson-Crawley Co., Barnesville, Ga. (K), 86.  
Happgood, E. & Son, Lowell, Mass. (W), 123.  
Happy Hollow Mill, Uxbridge, Mass. (W), 132.  
Haradon, Herbert H., Brooklyn, N. Y. (S), 164.  
Harden Mfg. Co., Harden, N. C. (C), 190.  
Harder Ktg. Co., Hudson, N. Y. (K), 170.  
Hargraves, E. (Hargraves Wln. Mill), 105.  
Hargraves, F. H. (Saco River Woolen Mills), 107.  
Hargraves Mills, Fall River, Mass. (C), 117.  
Hargraves Woolen Mill, No. Shapleigh, Me. (W), 105.  
Hargrove Cotton Mill Co., Shreveport, La. (C), 102.  
Harlem Knitting Mills (M. Neiman's Sons), 176.  
Harmony Grove Mills, Harmony Grove, Ga. (C), 89.  
Harmony Mills (Clayton G. Rice), 225.  
Harmony Mills, Cohoes, N. Y. (C), 167.  
Harold, Alex. (Harold Knitting Mills), 100.  
Harold Hosiery Mills Co., Philadelphia, Pa. (K), 217.  
Harold Knitting Mills, Covington, Ky. (K), 100.  
Harriet Cotton Mills, Henderson, N. C. (C), 190.  
Harriman Cotton Mill Co., Harriman, Tenn. (C), 269.  
Harriman, Josiah, Lowell, Mass. (C), 123.  
Harris Mfg. Co., Concord, N. C. (C), 187.  
Harris Mill (Simeon A. Wheaton), 78.  
Harris, T. A. & Co., Philadelphia, Pa. (D), 217.  
Harrisburg Knitting Mill, Harrisburg, Pa. (K), 238.  
Harrisburg Woolen Mills (Durfee, J. A.), 35.  
Harrison Yarn & Dyeing Co., Pawtucket, R. I. (C & D), 256.  
Harrison & Gore, Newburg, N. Y. (S), 172.  
Harrison & Mallatratt, Philadelphia, Pa. (K), 217.  
Harrisville Mill (Wm. Tinkham & Co.), 254.  
Harrow & Co., Paterson, N. J. (S), 156.  
Harrower, L. E., Amsterdam and Hagaman's Mills, N. Y. (K), 161, 169.  
Hart, A. H. Co., The, New York, N. Y. (J), 174.  
Hart, J. A., West Lebanon, Pa. (W), 249.  
Hart Mfg. Co., Flat Rock, N. C. (K), 188.  
Hart, Robert H., Asbland, N. H. (W), 143.  
Hart Textile Co., Woonsocket, R. I. (D Pr & F), 261.  
Hart & Klett, Camden, N. Y. (C), 166.  
Hartford Carpet Co., Thompsonville, Conn. (W), 81.  
Hartford Woolen Co., Hartford, Vt. (W), 275.  
Hartley, H. (Victoria Mills), 260.  
Hartley Silk Mfg. Co., Abertis and Topton, Pa. (S), 231, 249.  
Hartman, F. Q., Berwick and Danville, Pa. (S), 232, 236.  
Hartsville Cotton Mill, Hartsville, S. C. (C), 265.  
Harvard Knitting Mills (Winship, Boit & Co.), 132.  
Harvey, D. & Son, Philadelphia, Pa. (F), 217.  
Harvey Silk Co., Alfred, Forest City, Scranton, Pa. (S) 237, 247.  
Harvey, Wm. & Sons (Gardiner Shoddy Mills and Readfield Woolen Mills), 103, 106.  
Harvin, W. Scott, Manning, S. C. (K), 266.  
Hashuqua Mfg. Co., Hashuqua, Miss. (C), 140.  
Haskell Silk Co., Westbrook, Me. (S), 197.  
Haslam & Querner, Philadelphia, Pa. (D), 217.  
Hastings Wool Boot Co., Hastings, Mich. (W), 138.  
Hathaway Mfg. Co., New Bedford, Mass. (C), 126.  
Hatheway & Reynolds, Oriskany Falls, N. Y. (K), 179.  
Haubner, L. D., New York, N. Y. (K) 174.  
Havens, J., Washington, N. C. (C), 196.  
Haverstraw Dyeing Co., Haverstraw, N. Y. (D), 170.  
Hawley Knitting Mills (John Ballantyne & Sons), 203.  
Hawk Knitting Co., Reading, Pa. (K), 245.  
Hawkins, M. J. (Alpine Woolen Mills), 193.  
Hawkinsville Cotton Mills, Hawkinsville, Ga. (C), 89.  
Hawthorne Silk Co., Paterson, N. J. (C & S), 156.  
Haxton, W. B. & Co., Springdale, Ark. (W), 71.  
Hay & Todd Mfg. Co., Ann Harbor, Detroit and Ypsilanti, Mich. (K), 135, 137, 139.  
Hayden, Theo., Sandusky, N. Y. (W), 180.  
Hayes, John & Co., Philmont, N. Y. (K) 179.  
Hayner, George M., New York, N. Y. (J), 174.  
Haynes Morgan Co., New York, N. Y. (S), 174.  
Hayward, H. T., Franklin, Mass. (W) 119.  
Hayward Mills (B. T. Hayward) 119.  
Hayward, W. E. & Co., East Douglas, Mass. (W), 115.  
Hazard, A. G. (Pawtucket Braided Line Co.), 256.  
Hazelhurst Cotton Mill, Mt. Airy, N. C. (C), 193.  
Hazelton Silk Mill (Louis Roessel & Co.), 239.  
Hazle Knitting Mills Co., Hazleton, Pa. (K), 238.

- Health Underwear Co., Poquonock, Conn. (K), 78.  
 Heany, John (Cornell Knitting Co.), 150.  
 Heap, Chas. (Boston Finishing Works), 134.  
 Heathcote, L. K. & Co., Glen Rock, Pa. (W), 238.  
 Hebron Mfg. Co., Dodgeville, Hebronville, Mass., and Providence, R. I. (C), 115, 120, 258.  
 Hebron Mill (Hebron Mfg. Co.), 120.  
 Hecht, S. L. & L. Rittenberg (Saxton's River Worsted Mill), 275.  
 Heebner, Geo. W. & Son, Port Carbon, Pa. (K) 244.  
 Heinemann, Harry J. & Co., Philadelphia, Pa. (Pr), 217.  
 Heinig, Louis, Cleveland, Wis. (K), 281.  
 Heinrich, Gustav, Cuero, Texas (K), 271.  
 Hellwell & Co., Pittsfield, Mass. (W), 129.  
 Hellmer, M., Philadelphia, Pa. (K), 217.  
 Hellwig, Albert & Co., Philadelphia, Pa. (D), 217.  
 Helmus, G., New York, N. Y. (S), 174.  
 Helvetia Silk Mill, Paterson, N. J., and Lehigh-ton, Pa. (S), 156, 240.  
 Heminway, M. & Sons Silk Co., Watertown, Conn. (S), 81.  
 Heminway & Bartlett Silk Co., Watertown, Conn. (S), 81.  
 Hendel, Geo. & Sons, Reading, Pa. (W), 245.  
 Hendel Hat Co., Reading, Pa. (W), 245.  
 Hendel, Wm. B., Reading, Pa. (K), 245.  
 Henderson Cotton Mills, Henderson, Ky. (C), 100.  
 Henderson Cotton Mills, Henderson, N. C. (C), 190.  
 Henderson Mfg. Co., Hampton, Ga. (K), 89.  
 Henderson, Wm., Philadelphia, Pa. (W), 217.  
 Henderson Woolen Mills, Henderson, Ky. (W), 100.  
 Henkels, Alb. & E., Schenectady, N. Y. (C), 180.  
 Henrietta Mills, The, Henrietta, N. C. (C), 190.  
 Henry Carpet Shop, Henry, Ill. (W), 95.  
 Henry, H. S., Philadelphia, Pa. (W), 217.  
 Henry, Thos., Jr., & Co., Milton, Pa. (C), 241.  
 Henry, Thos. & Sons, Philadelphia, Pa. (W), 217.  
 Hensel, Colladay Co., Philadelphia, Pa. (S), 217.  
 Hensel Silk Mfg. Co., Philadelphia, Pa. (S), 217.  
 Henshall Bros., New York, N. Y. (F), 174.  
 Henshall, Thos., Paterson, N. J. (F), 156.  
 Hepler, John, No. Grafton, Mass. (W), 1288.  
 Hepler & Horwitz, New York, N. Y. (C), 174.  
 Herbst, Albert & Co., Philadelphia, Pa. (W), 217.  
 Heritage & Hirst, Monson, Mass. (W), 125.  
 Herman, A., Paterson, N. J. (S), 156.  
 Hertlein, C. E., New York, N. Y. (S), 175.  
 Hertzler, H. H., Burnt Cabins, Pa. (W), 234.  
 Herzog, L. & Co., New York, N. Y. (K), 175.  
 Hess, Goldsmith & Co., Wilkesbarre, Pa. (S), 250.  
 Hessler, Em. Surgical Ins. Co., Cleveland, O. (K), 198.  
 Hetrick, Wm. A. & Bro., Philadelphia, Pa. (K), 217.  
 Hetzel, Geo. C. Co., Chester, Pa. (W), 235.  
 Hewett, C. G., Philadelphia, Pa. (C), 217.  
 Hewitt, W. P. & Co., Menasha, Wis. (W), 281.  
 Hey, Benj. & Co., Cincinnati, Ohio (W), 198.  
 Hey, David, Philadelphia, Pa. (W), 217.  
 Hey, E. & Co., Clifton Heights, Pa. (W), 236.  
 Hey, Richard & Son, Philadelphia, Pa. (W), 217.  
 Heymer, Edward, Philadelphia, Pa. (W), 217.  
 Heywood Narrow Fabric Co., Fall River, Mass. (C), 117.  
 Hiawatha Mfg. Co., Gibsonville, N. C. (C), 189.  
 Hiester & Hirst, Womelsdorf, Pa. (K), 250.  
 Higgenbotham & Co. (Pioneer Silk Factory), 72.  
 Higgins, D. A. & Co., New York, N. Y. (D), 175.  
 High Falls Mfg. Co., High Falls, N. C. (C), 190.  
 High Rock Knitting Co., Philmont, N. Y. (K), 179.  
 High Shoals Company, High Shoals, N. C. (C), 190.  
 High Shoals Mfg. Co., High Shoals, Ga. (C), 89.  
 Highland City Mills, Talladega, Ala. (C), 70.  
 Highland Embroidery Works, Highland, Ill. (S), 95.  
 Highland Knitting Mill, Utica, N. Y. (K), 182.  
 Highland Mill (Mossley & Co.), 120.  
 Highland Park Mfg. Co., Charlotte, N. C., and Rock Hill, S. C. (C), 185, 267.  
 Highland Worsted Mills, Camden, N. J. (W), 148.  
 Hightstown Smyrna Rug Co., Hightstown, N. J. (W) 151.  
 Hill, G. L. Mrs., Smithfield, Me. (W), 107.  
 Hill Mfg. Co., Lewiston, Me. (C), 105.  
 Hill, Wm., Philadelphia, Pa. (C), 217.  
 Hill, William, Pawtucket, R. I. (C), 256.  
 Hilliard, E. E. Co., The, Buckland, Conn. (W), 73.  
 Hillier, S. B., Cooperstown, Pa. (W), 236.  
 Hills, Wm. G. (Premier Hosley Mills) 142.  
 Hillsboro Cotton Mill Co., Hillsboro, Texas (C), 272.  
 Hillsboro Woolen Mill Co., Hillsboro Bridge, N. H. (W), 145.  
 Hillsboro Woolen Mills, Hillsboro, O. (W), 199.  
 Hillsborough Mills, Wilton, N. H. (W), 148.  
 Hilton, James, Auburn, Mass. (W), 111.  
 Himberg, J., New York, N. Y. (S), 175.  
 Himes Underwear Co., Cohoes, N. Y. (K), 167.  
 Hind & Harrison Plush Co., The, Clark's Mills, N. Y. (S), 166.  
 Hinkle, C. K. & Son, Shippensburg, Pa. (W), 247.  
 Hinsdale Woolen Co., Hinsdale, Mass. (W), 120.  
 Hird, Samuel (Robertson Wst. Mills), 154.  
 Hirschman, A. Philadelphia, Pa. (W), 217.  
 Hirsch & Lazareth, Norristown, Pa. (W), 242.  
 Hirsch & Park, Medway, Mass. (W), 124.  
 Hirschkind, D. (Peerless Knitting Mills), 165.  
 Hirst, W. H., Rahway, N. J. (W), 158.  
 Hirst Smyrna Rug Co., Vineland, N. J. (W), 159.  
 Hirst & Roger, Philadelphia, Pa. (W), 217.  
 Hitchcock Ktg. Mill, Longmeadow, Mass. (K), 122.  
 Hitchcock & Curtiss Knitting Co., Hartford, Conn. (K), 75.  
 Hitchon, W. G. (Otrobando Woolen Mill and Glen Woolen Mills, The), 78, 80.  
 Hitchon, W. W., Philadelphia, Pa. (C & W), 217.  
 Hoag, C. F., Poughkeepsie, N. Y. (K), 179.  
 Hoboken Silk Dye Works, Hoboken, N. J. (D), 151.  
 Hockaday, Robt., No. Billerica, Mass. (K), 128.  
 Hockanum Co., Rockville, Conn. (W), 79.  
 Hockmeyer Bros. (Waterhead Mills), 124.  
 Hodges Fibre Carpet Co., Indian Orchard, Mass. (F), 121.  
 Hodgson Bros., Camden, N. J. (W), 148. (See also Too Late Classification List.)  
 Hodgson, E. A., Laconia, N. H. (D), 145.  
 Hodson, John M., Philadelphia, Pa. (C & J), 217.  
 Hofmann & Ellrodt, New York, N. Y. (S), 175.  
 Hoffman, Corr Mfg. Co., Philadelphia, Pa. (C & J), 217.  
 Hoffman Mfg. Co., Philadelphia, Pa. (C) 217.  
 Hoffman & Dohner, Schuylkill Haven, Pa. (K), 246.  
 Hoffman & Shelton (Diamond Ktg. Mills), (K), 250.  
 Hoffmeister, Albert F., Co., Cincinnati, Ohio (S), 198.  
 Hoffstadt, William, New York, N. Y. (K), 175.  
 Hogansville Mfg. Co., Hogansville, Ga. (C), 89.  
 Hogg Carpet Co., Auburn, Mass. (W), 111.  
 Hogg, Chas. & Bro., Philadelphia, Pa. (K), 217.  
 Hogg, Wm., Jas. & Co., Auburn, Mass. (W), 111.  
 Hohrath & Fickert, Bethlehem, Pa. (S), 233.  
 Holbrook Mfg. Co., Millbury, Mass. (C) (See Too Late Classification List.)  
 Holden, Edwin & Co., Philadelphia, Pa. (C), 218.  
 Holden, Jas., Fall River, Mass. (C), 117.  
 Holden, Leonard & Co., New Bedford, Mass., and Bennington, Vt. (W), 126, 273.  
 Holden, Wm. R., Paterson, N. J. (S), 156.  
 Holden & Fuller, Palmer, Mass. (W), 129.  
 Holdsworth, Frederick, Philadelphia, Pa. (S), 218.  
 Holdsworth & Arthur, Philadelphia, Pa. (C), 218.  
 Holland Mfg. Co., Willimantic, Conn. (S), 83.  
 Hollbach, John & Co., Paterson, N. J. (S), 156.  
 Hollings & Smith, Lawrence, Mass. (W), 122.  
 Holliston Mills, Holliston, Mass. (W), 120.  
 Hollmann & Sellhaus, New York, N. Y. (C), 175.  
 Hollywood Mfg. Co., Hollywood, W. Va. (W & K), 279.  
 Holmes, Archibald & Son, Philadelphia, Pa. (W), 218.

- Holmes City Woolen Mill (G. M. Johnson), 139.  
 Holmes Co., The, Boston, Mass. (K), 112.  
 Holmes, John C., Co., Springfield, Vt. (C), 275.  
 Holmes, Jno. G., Philadelphia, Pa. (K), 218.  
 Holmes, Henry & Sons, Philadelphia, Pa. (W), 218.  
 Holmes, I., Cincinnati, Ohio (K), 198.  
 Holmes Silk Co., Paterson, N. J., and Williamsport, Pa. (S), 156, 250.  
 Holroyd, Jas., Albany, N. Y. (K), 161.  
 Holroyd, Simeon, Albany, N. Y. (K), 161.  
 Holstein, S., New York, N. Y. (S), 175.  
 Holstein Woolen Co., Salem, Va. (W), 278.  
 Holt, E. M., Plaid Mills, Burlington, N. C. (C), 185.  
 Holt, Gant & Holt, Elon College, N. C. (C), 188.  
 Holt Granite Mfg. Co., Haw River, N. C. (C), 190.  
 Holt, John P., Philadelphia, Pa. (W), 218.  
 Holt, L. Banks, Graham, N. C. (C), 189.  
 Holt, Lawrence S. & Sons (Aurora Gotton Mills), 185.  
 Holt Mfg. Co., Camden, N. J. (K), 148.  
 Holt Morgan Mills, Fayetteville, N. C. (C), 188.  
 Holt, R. L. & J. H., Jr., Burlington, N. C. (C), 185.  
 Holt Silk Co., The, Midland Park, N. J. (S), 152.  
 Holt, Thos. M., Mfg. Co., Haw River, N. C. (C), 190.  
 Holt, William, Paterson, N. J. (C), 156.  
 Holt, W. E. (Wenonah Cotton Mills), 191.  
 Holt-Williamson Mfg. Co., Fayetteville, N. C. (C), 188.  
 Holt's Son, E. M. (Alamance Factory), 184.  
 Holtzizer, H. E. & J. C., Williamsport, Pa. (W), 250.  
 Holyoke Plush Co., Holyoke, Mass. (W), 120.  
 Holyoke Thread Co., Holyoke, Mass. (D & F), 120.  
 Holyoke Warp Co., Holyoke, Mass. (C), 120.  
 Holzman Silk Mfg. Co., Paterson, N. J. (S), 156.  
 Home Bleach & Dye Works, Pawtucket, R. I. (D & B), 256.  
 Home Cotton Mills Co., St. Louis, Mo. (C), 142.  
 Home Knitting Works, Salt Lake City, Utah (K), 273.  
 Home Mill (Rawtser & Bro.), 80.  
 Home of Refuge (Industrial Seamless Hosiery Mills), 175.  
 Home Silk Mills, Haverstraw, N. Y. (S), 170.  
 Home Woolen Mills, Home, Tenn. (W), 269.  
 Homer Woolen Mills (Newton & Co.), 170.  
 Honeypath Cotton Mills, Honeypath, S. C. (C), 265. (Also See Chiquola Cotton Mills, Too Late Classification.)  
 Hoof & Matter Silk Dyeing Co., New York, N. Y. (D), 175.  
 Hooley, B. & Son, Philadelphia, Pa. (S), 218.  
 Hooper Knitting Co., Lowell, Mass. (K), 123.  
 Hooper Sons Mfg. Co., Philadelphia, Pa. (C & S), 218.  
 Hoosick Falls Hosiery Co., Hoosick Falls, N. Y. (K), 170.  
 Hoosier Dye Works & Mfg. Co., New Albany, Ind. (W & D), 98.  
 Hooven & Allison Co., Xenia and Zanesville, O. (C & F), 201.  
 Hope Carpet Mills (D. Jamieson's Sons), 218.  
 Hope Co., Hope, R. I. (C), 254.  
 Hope Knitting Co., Cohoes, N. Y. (K), 167.  
 Hope Mills Mfg. Co., Hope Mills, N. C. (C), 190.  
 Hope Webbing Co., Pawtucket, R. I. (C & S), 256.  
 Hope Worsted Mills Louisville, Ky. (W), 101.  
 Hope Worsted Mills, Oakland, R. I. (W), 255.  
 Hopell Woolen Mill (Geo. Keseling), 237.  
 Hopewell Mfg. Co., Worcester, Mass. (W), 134.  
 Hopewell Mill (Glazier, Frankln & Son), 80.  
 Hopewell Mills, Taunton, Mass. (C), 121.  
 Hopper & Scott, Paterson, N. J. (S), 156.  
 Horn Silk Co., Titusville, Pa. (S), 249.  
 Horner Bros. (Eaton Rapids Woolen Mills), 137.  
 Horrocks & Bro., Philadelphia, Pa. (D & F), 218.  
 Horstmann, Wm. H. Co., Philadelphia, Pa. (S), 218.  
 Hough, Mark, Woonsocket, R. I. (D), 261.  
 Houlton Woolen Mills, Houlton, Me. (W & K), 103.  
 Houston Factory, Dennard, Ga. (C), 88.  
 Houston Mfg. Co., Chester, Pa. (C), 235.  
 Hover, J. A., Columbiaville, N. Y. (K & C), 168.  
 Howard, Geo. T., Craftsbury, Vt. (W), 275.  
 Howard Mfg. Co., Boston, Mass. (C), 112.  
 Howard Mill (John Scanlin & Son), 225.  
 Howard & Buck, Carthage, N. Y. (K), 166.  
 Howard & Co., Rahway, N. J. (D), 159.  
 Howarth, A. & Son, Oxford and Rochdale, Mass. (W), 123, 130.  
 Howland Mills, New Bedford, Mass. (C), 126.  
 Hoxie & Scripture, Acme, Mich. (W), 135.  
 Hoyle, Harrison & Kaye, Philadelphia, Pa. (S), 218.  
 Hub Gore Makers, Boston, Mass. (C), 112.  
 Hub Hosiery Mills, Boston, Mass. (K), 112.  
 Hucomgo Mills, Greensboro, N. C. (C), 190.  
 Hudson Bros., Little Falls, N. Y. (W), 171.  
 Hudson Fibre Co., Hudson, N. Y. (W), 170.  
 Hudson River Hosiery Mill (Newland, Denison & Co.), 181.  
 Hudson River Woolen Mills, Newburg, N. Y. (W), 173.  
 Hudson Worsted Co., Hudson, Mass. (W), 121.  
 Huey, S. C., Ruston, La. (C), 102.  
 Huf, Chas. P., Philadelphia, Pa. (K), 218.  
 Hughes, J. A. (Centre Point Woolen Mills), 70.  
 Hughes, J. L. (Mississippi Knitting Mills), 141.  
 Hughes, M. C. (Bristol Hosiery Mills), 234.  
 Hughes Mfg. Co., The, Philadelphia, Pa. (C & D), 218.  
 Huguenot Mills, Greenville, S. C. (C), 265.  
 Hull, Smith & Co., Amsterdam, N. Y. (K), 161.  
 Hulton Dyeing & Finishing Co., Philadelphia, Pa. (D & F), 218.  
 Humbert, W. B. (Santa Rosa Woolen Mills), 72.  
 Humboldt Cotton Mills, Humboldt, Tenn. (C), 269.  
 Humboldt Bay Woolen Mills Co., Eureka, Cal. (W), 71.  
 Hummelstown Hosiery Co., Hummelstown, Pa. (K), 239.  
 Humphreys, Seth, Gladwyne, Pa. (W), 238.  
 Hunt, A. H. (Hunts Woolen Mill), 170.  
 Hunts Mill (Philp Pfaffman), 114.  
 Hunts Woolen Mill, Honeoye Falls, N. Y. (W), 170.  
 Huntingburg Woolen Mills (The Miessner Bros. Co.) 97.  
 Huntington Knitting Mill Co., Huntington, Ind. (K), 37.  
 Huntsville Cotton Mills, Huntsville, Ala. (C), 69.  
 Hurricane Creek Mfg. Co., Spring Garden, Ala. (C), 70.  
 Hussong, Joseph, Camden, N. J. (D), 149.  
 Husted, A. P., Tarrytown, N. Y. (S), 181.  
 Huston, Thos. & Co., Philadelphia, Pa. (W), 218.  
 Hutcheson Mfg. Co., Banning, Ga. (C), 86.  
 Hutchins Narrow Fabric Co., Springfield, Mass. (C & S), 131.  
 Hutchinson, Saml., East Brook, Pa. (W), 237.  
 Huyck, F. C. & Sons, Albany, N. Y. (W), 161.  
 Hygienic Blanket Co., Hubbardston, Mass. (W), 121.  
 Hygienic Fibre Co., New York, N. Y. (K), 175.  
 Hygienic Fleece-Lined Underwear Co., Philadelphia, Pa. (K), 218.  
 Hyndman & Moore Co., Philadelphia, Pa. (S), 218.  
 Hyrum Woolen Mills, Hyrum City, Utah (W & K), 273.  
 Iceman Mills, McCall, S. C. (C), 266.  
 Ida Yarn Mill, Laurel Hill, N. C. (C), 191.  
 Ideal Knitting Works, Rochester, N. Y. (K), 180.  
 Iginfritz, Geo. W. & Co., Greencastle, Pa. (W), 228.  
 Iliffe, John, Philadelphia, Pa. (D), 218.  
 Imperial Braiding Mills (Hooper Sons Mfg. Co.), 218.  
 Imperial Knitting Co., Ionia, Mich. (K), 138.  
 Imperial Knitting Mill, Brooklyn, N. Y. (K), 161.  
 Imperial Mill (Verlenden Bros.), 236.  
 Imperial Woolen Co., Philadelphia, Pa. (W), 218.  
 Indelible Dye Works (E. Sutro & Son), 237.  
 Index Knitting Co. (J. P. Morin & Co.), 145.  
 Index Knitting Mills, Phoenix Mills, N. Y. (K), 179.  
 Indian Creek Mills, Lincolnton, N. C. (C), 192.

- Indian Head Mills of Alabama, Cordova, Ala. (C), 67.
- Indian Orchard Co., Indian Orchard, Mass. (C & D) 121.
- Indian Spring Woolen Co., Madison, Me. (W), 105.
- Indiana Cotton Mills, Cannelton, Ind. (C), 96.
- Indiana Warp Mills, Indianapolis, Ind. (C), 97.
- Indiana Woolen Mills Co., Indiana, Pa. (W), 239.
- Indianapolis Bleaching Co., Indianapolis, Ind. (B), 97.
- Indianola Cotton Mills, Davis, Indian Territory (C), 98.
- Industrial Dyeing & Finishing Works, Philadelphia, Pa. (D & F) 218.
- Industrial Hosiery Mills, Mohn's Store, Pa. (K), 241.
- Industrial Seamless Hosiery Mills, New York, N. Y. (K), 175.
- Industry Knitting Mills (Woodcock Bros.), 230.
- Industry Mill (Fichtorn Redcay & Co.), 231.
- Ineson, Thomas, New York, N. Y. (S), 175.
- Ingham, J. S., Academy Corners, Pa. (W), 231.
- Ingham, John & Co., Jamestown, N. Y. (W), 171.
- Inglis & Co., Paterson, N. J. (S), 156.
- Ingram, David, Estate of, Astoria, N. Y. (D), 163.
- Ingram, Wm. A., Philadelphia, Pa. (B) 218.
- Inman Mills, Inman, S. C. (C) 266.
- Integrity Knitting Mills, Philadelphia, Pa. (K) 218.
- Interlaken Mills, Arkwright & Phenix, R. I. (C) 251, 257.
- Invincible Knitting Co., Pawtucket, R. I. (K) 256.
- Iowa Knitting Co., Des Moines, Iowa (K) 99.
- Iowa State Penitentiary, Fort Madison, Iowa (K) 99.
- Ipava Woolen Mills (Foote, C. F.) 95.
- Ipswich Mills, Boston and Ipswich, Mass. (K) 112, 121.
- Irent Mills, Franklin, Idaho (W & K) 92.
- Iroquois Knitting Mills, Philadelphia, Pa. (K) 218.
- Iroquois Mill (Walcott & Campbell Spinning Co.) 178.
- Ironstone Woolen Co., Uxbridge, Mass. (W) 132.
- Irving, James & Son, Chester, Pa. (W) 235.
- Irving, J. G., Danbury, Conn. (S) 73.
- Irving Mfg. Co., New Brighton, S. L., N. Y. (C) 172.
- Irving & Leiper Mfg. Co., Chester, Pa. (C) 235.
- Irvington Woolen Mills (James Irving & Son) 235.
- Irwell Mills (Richard Thorpe) 238.
- Irwin, A. D. & Bro., Philadelphia, Pa. (W) 218.
- Irwin County Cotton Mills, Fitzgerald, Ga. (C) 88.
- Isaac, S. (Buffalo Silk Mfg. Co.) 154.
- Isaetta Mill, The, Augusta, Ga. (C) 86.
- Iselin, Sebastian (Stockton Rug & Carpet Manufactory) 72.
- Iskiyan, H., New York, N. Y. (W) 175.
- Island Woolen Co., Baraboo, Wis. (W) 280.
- Isleib & McLane, Paterson, N. J. (S) 156.
- Itasca Cotton Mfg. Co., Itasca, Texas (C) 272.
- Iverson Sterne Mfg. Co., Milner, Ga. (C) 90.
- Ivins, Dietz & Merger Co., Philadelphia and Norristown, Pa. (W) 218, 242.
- Jaburg, Fuhs & Lovin, New York, N. Y. (K) 175.
- Jackson Co., Nashua, N. H. (C) 146.
- Jackson, David & Son, Philadelphia, Pa. (W) 218.
- Jackson Fibre Co., Jackson, Tenn. (C) 269.
- Jackson, James & Sons, Paterson, N. J., and Little Falls, N. J. (D & F) 152, 156.
- Jackson Mills, Fiskville, R. I. (C) 253.
- Jackson, Thos. & Son, Reading, Pa. (J) 245.
- Jackson Woolen Mills, Jackson, Tenn. (W) 269.
- Jacksonville Knitting Co., Jacksonville, Fla. (K) 84.
- Jacobs Cordage Co., The, Cincinnati, Ohio (J) 198.
- Jacobs, Wm. H. (Haleyon Knitting Mills) 248.
- Jaeger & Halsey, Brooklyn, N. Y. (S) 164.
- James, G. L., Philadelphia, Pa. (W) 218.
- Jamestown Cotton Mills, Jamestown, N. Y. (C) 171.
- Jamestown Woolen Mills, Jamestown, N. Y. (W) 171.
- Jamestown Worsted Mills, Jamestown, N. Y. (W) 171.
- Jamesville Woolen Mill, Worcester, Mass. (W) 134.
- Jamieson's, D., Sons, Philadelphia, Pa. (W) 218.
- Jansen & Pretzel, Paterson, N. J. (S) 156.
- January & Wood Co., Maysville, Ky. (C) 101.
- Jarvis, David, Agt., Philadelphia, Pa. (K) 218.
- Jefferson City Woolen Mills, Jefferson City, Tenn. (W) 270.
- Jefferson Cotton Mills, Jefferson, Ga. (C) 89.
- Jefferson Mfg. Co., Jefferson, Mass. (W) 121.
- Jenckes, E., Mfg. Co., Pawtucket, R. I. (C) 256.
- Jenkins Mfg. Co., East Braintree, Mass. (C) 115.
- Jenkins, L., Paterson, N. J. (W) 156.
- Jenks, J. P., North Brook, N. C. (W) 193.
- Jenks, W. A., Philadelphia, Pa. (W) 219.
- Jennings, Abraham & Albert G. (Jennings Lace Works) 154.
- Jennings Lace Works, Brooklyn, N. Y. (S & K) 164.
- Jennings, R. G. (Queen City Knitting Mills), 168.
- Jensen, Joseph, Chicago, Ill. (K) 93.
- Jersild Knitting Co., Neenah, Wis. (K) 282.
- Jewell Cotton Mills (Bowen, Jewell & Co.) 89.
- Johns Manville Co., H. W., Brooklyn, N. Y. (A) See Too Late Classification List.
- Johnson Bros., Bovina, N. Y. (W) 163.
- Johnson, Cowdin & Co., Paterson, N. J. and Phoenixville, Pa. (S) 156, 243.
- Johnson, E. Emory, Moodus, Conn. (C) 76.
- Johnson, G. M., Holmes City, Minn. (W) 139.
- Johnson, Jos., Philadelphia, Pa. (W) 219.
- Johnson, J. L., Oneida, N. Y. (K) 178.
- Johnson, J. S. Co., Baltimore, Md. (C) 107.
- Johnson, J. Wesley, Philadelphia, Pa. (W) 219.
- Johnson Mfg. Co., North Adams, Mass. (C) 127.
- Johnson, R., Yarn and Cordage Mills, Madison, Ind. (C) 97.
- Johnson & Bemis (Merchants' Print Works) 176.
- Johnson & Johnson, New Brunswick, N. J. (C & K) 153.
- Johnston Bros., Philadelphia, Pa. (W) 219.
- Johnston, C. B. (Norfolk Knitting Mills) 277.
- Johnston, David S., Cohoes, N. Y. (K) 167.
- Johnston & Co., New York, N. Y. (C) 175.
- Johnstown Knitting Co., Johnstown, N. Y. (K) 171.
- Jonas, Wm. & Co., New York, N. Y. (C) 175.
- Jones, Geo. F. & Son, Philadelphia, Pa. (K) 219.
- Jones, H. C. Co., Conshohocken, Pa. (W) 236.
- Jones, J. F., Laurel, N. C. (C) 191.
- Jones, J. S. (Manchester Woolen Mills) 99.
- Jones, Lewis, Knitting Co., Brunswick, Md., and Winchester, Va. (K) 108, 278.
- Jones, Newton, Philadelphia (W) 219.
- Jones & Green (Anatolian Rug Mfg. Co.) 203.
- Jonesboro Yarn Mills, Jonesboro, Tenn. (C) 270.
- Jonesville Knitting Mills, Jonesville, S. C. (K) 266.
- Jordan, C. N., Rotherwood, Tenn. (W) 271.
- Jordan Mfg. Co., Chester, Pa. (C) 235.
- Josephine Mills, The, Cedartown, Ga. (K) 86.
- Josephs & Herbst, Philadelphia, Pa. (S) 219.
- Jostin Mfg. Co., Providence, Rockland and So. Scituate, R. I. (C) 258, 259.
- Jowett, John W., Methuen, Mass. (W) 125.
- Juanita Cotton Mills, Burlington, N. C. (C) 185.
- Jung & Turnbull, New York, N. Y. (S) 175.
- Juniata Carpet Mills (Kaufman & Harley) 241.
- Juniata Knitting Mill, Duncannon, Pa. (K) 237.
- Junlata Throwing Co., Altoona, Pa. (S) 231.
- Kaaterskill Hosiery Mills (Wiley Mfg. Co.) 166.
- Kaatz, T. & Co., New York, N. Y. (C & S) 175.
- Kagermann, Edward (Charlotte Dye Works) 209.
- Kalamazoo Knitting Co., Milwaukee, Wis. (K) 281.
- Kaltenbach & Stephens, Brooklyn, N. Y. (S) 161.
- Kanawha Woolen Mills, Charleston, W. Va. (W) 279.
- Kansas Fibre Co. (Wm. H. Payne) 199.
- Kansas Twine Co., Independence, Kansas (C) 99.
- Kanter, I., Paterson, N. J. (S) 156.
- Kantner, S. H. & Co., Somerset, Pa. (W) 247.
- Kapner Bros. & Duga Hosiery Co., Barnesville and Dresden, Ohio (K) 197, 199.

- Karl & Schott, Mifflintown, Pa. (K) 241.  
 Kattermann, E. G. & Co. (Swiss Ktg. Co.) 149.  
 Kattermann & Mitchell, Paterson, N. J., and  
 Port Jervis, N. Y. (S) 156, 179.  
 Kauffman, Jas. K., Reading, Pa. (K) 241.  
 Kauffman, W. H., Athol, Mass. (W) 115.  
 Kauffman Bros., Paterson, N. J. (S) 156.  
 Kaufman Knitting Mills, Lititz, Pa. (K) 240.  
 Kaufmar, Leo & Co., Nashville, Tenn. (K) 270.  
 Kaufman, S., Co., New York, N. Y. (S) 175.  
 Kaufman & Harley, Mifflintown, Pa. (W) 241.  
 Kaufmann & Schrader, New York, N. Y. (F) 175.  
 Kavanagh, F. W., Mfg. Co., Cohoes, N. Y. (K)  
 167.  
 Kavanagh Knitting Co., Waterford, N. Y. (K)  
 183.  
 Kay, Thos. Woolen Mills Co., Salem, Ore. (W) 201.  
 Kayser, Julius & Co., Hartford, Conn., Brooklyn  
 and New York, N. Y. (K) 75, 164, 175.  
 Kearney Cotton Mills, Kearney, Neb. (C) 142.  
 Kearns Bros., Paterson, N. J. (D) 156.  
 Kedward, Wm., Philadelphia, Pa. (D) 219.  
 Keefer, Jerome N. Mrs., Camillus, N. Y. (K)  
 166.  
 Keefer, Wm. B., Philadelphia, Pa. (W) 219.  
 Keefer, W. F. (Middlesex Knitting Mills) 166.  
 Keegan, Lawrence, Wilsonville, Conn. (W) 83.  
 Keegan, Wm., Philadelphia, Pa. (C) 219.  
 Keen & Kniley, Lykens, Pa. (K) 240.  
 Keim, J. R. & Co., Philadelphia, Pa. (W) 219.  
 Keller, G. S., Houserville, Pa. (W) 239.  
 Keller & Van Dunker, Del Rio, Texas (W) 271.  
 Kelley, Thomas & Co. (Columbia Mills) 165.  
 Kellogg & Gage (Adhesive Gimp Co.) 173.  
 Kelly, Edward W., Philadelphia, Pa. (K) 219.  
 Kelly, Francis, Philadelphia, Pa. (W) 219.  
 Kelly, R. A. Company, Xenia, O. (F) 201.  
 Kemmerling, Wm., Philadelphia, Pa. (W) 219.  
 Kempf Bros., Philadelphia, Pa. (C) 219.  
 Kempkes Bros., Paterson, N. J. (S) 156.  
 Kennall Knitting Co., Utica, N. Y. (K) 182.  
 Kendrick, Jas. R., Philadelphia, Pa. (K) 219.  
 Kennebec Mills, Fairfield, Me. (W) 163.  
 Kennebec Spinning Mills, Richmond, Me. (C) 106.  
 Kennebec Worsted Co., Ltd., Philadelphia, Pa.  
 (W) 219.  
 Kennedy, D. & Sons (Monticello Woolen Mills)  
 282.  
 Kennedy & Britt, Philadelphia, Pa. (D) 219.  
 Kensington Dye Works (T. Brophy's Sons) 207.  
 Kensington Hammock Mill (James McKechnie) 221.  
 Kensington Knitting Mill (Justus Koch & Co.)  
 219.  
 Kensington Skein Silk Dye Works, Philadelphia,  
 Pa. (D) 219.  
 Kensington Woolen Mills (Wm. Thornton) 228.  
 Kent, M. A., Enosburgh Falls, Vt. (W & K) 275.  
 Kent Mfg. Co., Centerville, R. I. (W) 253.  
 Kent, P. G. Gamesville Woolen Mill 134.  
 Kent, Thos. Mfg. Co. (Geneva Knitting Mills),  
 Philadelphia, and Clifton Heights, Pa. (K  
 & W) 216, 236.  
 Kentuck River Mills, Frankfort, Ky. (F) 160.  
 Kentworthy, J. & Bro., Philadelphia, Pa. (W) 219.  
 Kenworthy, John, Hampden, Mass. (W) 120.  
 Kenyon, E. & Son, Kenyon, R. I. (W) 254.  
 Kenyon, John J. Mfg. Co., Pawtucket, R. I. (C)  
 256.  
 Kenyon, John T., Woodville, R. I. (C) 260.  
 Kenyon Mill, So. Coventry, Conn. (W) 80.  
 Kerkeslager, Irvin C., Philadelphia, Pa. (C) 219.  
 Kerper, J. F. (Southern Woolen Mills) 191.  
 Kerr Bag Mfg. Co., Concord, N. C. (F & B) 187.  
 Kerr, James H., Philadelphia, Pa. (C) 219.  
 Kerr Thread Co., Fall River, Mass. (C) 117.  
 Kershaw, John W., Philadelphia, Pa. (C) 219.  
 Kershaw, Nelson, Ltd., Clifton Heights, Pa. (C)  
 236.  
 Kesling, Geo., Draco, Pa. (W) 237.  
 Kester Mfg. Co., Salisbury, N. C. (C) 184. (See  
 also Too Late Classification List.)  
 Kessler, C. F. & Sons, Reading, Pa. (W) 245.  
 Kessler, Jacob C. & Co., Mohr's Store, Pa. (W)  
 241.  
 Kesterson, A. B., Cumberland Gap, Tenn. (W) 269.  
 Keutel, Julius, Jersey City, N. J. (S) 151.  
 Keystone Braid Mills (Loeb, Lipper & Co.) 220.  
 Keystone Carpet Mills (Thos. Caves & Sons) 209.  
 Keystone Cordage Wks. (Thos. McComesky) 221.  
 Keystone Dye Works (John Nolan) 223.  
 Keystone Fast Black Dye Wks., Philadelphia,  
 Pa. (D) 219.  
 Keystone Hosiery Co., Norristown, Pa. (K) 242.  
 Keystone Knitting Mills (Ulrich & Knull) 239.  
 Keystone Knitting Mills, Reading, Pa. (K) 245.  
 Keystone Mill (Somerset & Co.) 226.  
 Keystone Mills (Irvin C. Kerkeslager) 219.  
 Keystone Silk Weaving Co., Philadelphia, Pa.  
 (S) 219.  
 Keystone Spinning Mills Co., Philadelphia, Pa.  
 (W) 219.  
 Keystone Underwear Mills, Lititz, Pa. (K) 240.  
 Keystone Woolen Mills (Ed. T. Steel & Co.) 234.  
 Kezar Falls Woolen Mfg. Co., Kezar Falls, Me.  
 (W) 103.  
 Klamenski Woolen Co., Stanton, Del. (W) 84.  
 Kidney & Bridgen Co., Auburn, N. Y. (S) 163.  
 Kildbourn Knitting Machine Co., Martinsburg, W.  
 Va. (K) 279.  
 Killebrew, T. J., Newton, Ala. (C & W) 69.  
 Killan Bros., Philadelphia, Pa. (S) 219.  
 Kimball, W. C. & Co., Tallapoosa, Ga. (K) 91.  
 Klinead Mfg. Co., Griffin, Ga. (C) 89.  
 Kinderhook Knitting Co., Kinderhook, N. Y. (K)  
 171.  
 Kindley, W. R. Cotton Mills, Mt. Pleasant, N. C.  
 (C) 193.  
 King Knitting Mill (H. K. Deisher) 239.  
 King Mfg. Co., The John P., Augusta, Ga. (C)  
 86.  
 King Phillip Mills, Fall River, Mass. (C) 117.  
 King Silk Mills, Easthampton, Mass. (S) 115.  
 King & Prides Co., La Porte, Ind. (W) 97.  
 King's Mountain Mfg. Co., King's Mountain,  
 N. C. (C) 191.  
 Kingsboro Dye Works, Gloversville, N. Y. (D)  
 169.  
 Kingston Knitting Co., Boston, Mass. (K) 112.  
 Kingston Mills (Scheck & Goodman) 225.  
 Kinkelin, Ellsian & Katz (Washington Examining,  
 Sponging and Refinishing Works) 178.  
 Kinston Cotton Mills, Kinston, N. C. (C) 191.  
 Kirkham, John R., Glenbrook, Conn. (K) 75.  
 Kirlin & Gray (Watertown Tow Mill) 268.  
 Kistler, J. L. & Co. (Dellma Cotton & Woolen  
 Mills) 192.  
 Kitchen, James G. & Co., Philadelphia, Pa. (W)  
 219.  
 Kitchenman, John, Philadelphia, Pa. (D) 219.  
 Kitson, Thos. & Son, Stroudsburg, Pa. (W) 248.  
 Klahre, Hugo, New York, N. Y. (S) 175.  
 Klauder & Bros., Philadelphia, Pa. (D) 219.  
 Klein, Chas. C. (Integrity Knitting Mills) 218.  
 Klemer, C. H. & Sons, Fairbault, Minn. (W) 139.  
 Kline, Albert H., Schuylkill Haven, Pa. (K) 246.  
 Kline, Geo. W., Millersburg, Pa. (W) 241.  
 Klock, George, Estate of, Fayette, Iowa (W) 99.  
 Klots Throwing Co., Cumberland, Md., Carbon-  
 dale and Scranton, Pa. Fredericksburg, Va.  
 (S) 108, 214, 217, 277.  
 Klous, Henry, Methuen, Mass. (W) 125.  
 Knapp & Lowenthal, New York, N. Y. (S) 175.  
 Knause Bleachery (H. Knause) 238.  
 Knause, H., Hamburg, Pa. (B) 238.  
 Kneeder & Co., Philadelphia, Pa. (C) 219.  
 Knickerbocker Hosiery Mills, Mechanicsville,  
 N. Y. (K) 172.  
 Knickerbocker Ribbon Mills (Kaltenbach & Ste-  
 phens) (S) 164.  
 Knight, A. T., Woonsocket, R. I. (C) 261.  
 Knight, B. B. & R., Readville, Mass., Fiskville,  
 Natick, Phenix, Providence and River Point,  
 R. I. (C) 129, 253, 255, 257, 258, 259.  
 Knight & Shea, Malaga, N. J. (C) 152.  
 Knipe, W. E. (Philadelphia Dye Works) 224.  
 Knipscher & Maas Silk Dyeing Co., Paterson,  
 N. J. (D) 156.  
 Knitted Fabrics Co., Methuen, Mass. (K) 125.  
 Knitted Mattress Co., Canton Junction, Mass.  
 (K) 113.  
 Knoll & Althouse, Reading, Pa. (D) 245.

- Knowles, J. G. Woolen Co., New Castle, Del. (W) 23.  
 Knox Woolen Co., Camden, Me. (W) 102.  
 Knoxville Cotton Mills Co., Knoxville, Tenn. (C) 270.  
 Knoxville Knitting Mills Co., Knoxville, Tenn. (K) 270.  
 Knoxville Woolen Mills, Knoxville, Tenn. (C & W) 270.  
 Koch, Justus, Philadelphia, Pa. (K) 219.  
 Koch, Justus & Co., Philadelphia, Pa. (K) 219.  
 Koehn, Henry, Appleton, Wis. (W) 280.  
 Kohlmann Cottor Mill & Mfg. Co., New Orleans, La. (C) 102.  
 Kohn, Samuel S., New York, N. Y. (S) 175.  
 Kopp, J. J., Pottsville, Pa. (W) 244.  
 Kosciusko Cotton Mills, Kosciusko, Miss. (C) 140.  
 Koted Silk Underwear Co., Milbury, Mass. (C) 125.  
 Kotlowitz, Morris, Brooklyn, N. Y. (K) 165.  
 Kraemer, H., Nazareth, Pa. (K) 242.  
 Kraemer, Louis & Co., Reading, Pa. (W) 245.  
 Krager, J., Philadelphia, Pa. (C) 219.  
 Kraus, Chas. B., Philadelphia, Pa. (W) 219.  
 Kraus, R. & Son, New York, N. Y. (S) 176.  
 Kreese, F. C., New York, N. Y. (S) 176.  
 Kregeloh, H. J., Brooklyn, N. Y. (D) 165.  
 Kreider, A. R. & Bro., Anville, Pa. (K) 233.  
 Kremer, Chas. E., Philadelphia, Pa. (K) 219.  
 Kremer, Theo. E. & Co., Philadelphia, Pa. (K) 220.  
 Kressel, H. & Co. (Rockport Woolen Mills) 98.  
 Kretzschmar, J. O., Memphis, Tenn. (C) 270.  
 Kreusser & Buscher, New York, N. Y. (D) 176.  
 Kriebel, Chas., Philadelphia, Pa. (W) 220.  
 Kring & Steffey (Beau Ideal Knitting Mills) 241.  
 Krook & Bruch Co., Philadelphia, Pa. (W) 220.  
 Krout & Fite Mfg Co., Philadelphia, Pa. (C & S) 220.  
 Kruger & Stohn, Paterson, N. J. (S) 156.  
 Kuersten & Rick, Reading, Pa. (K) 245.  
 Kuestner, John, Philadelphia, Pa. (W) 220.  
 Kuhlen, Fred, Hoboken, N. J. (K) 151.  
 Kunhardt, Geo. E., Lawrence, Mass. (W) 122.  
 Kupta, Frank (Royer's Ford Dye Works) 246.  
 Kursheedt Mfg. Co., The, New York, N. Y. (S) 176.  
 Kutz Bros., Fleetwood, Pa. (K) 237.  
 Kutztown Silk Throwing Mills, Kutztown, Pa. (S) 229.  
 Laboratory Cotton Mills, Lincolnton, N. C. (C) 192.  
 Lackawanna Mills, Scranton, Pa. (K) 247.  
 Lackey, Geo. E. Newburgh, N. Y. 173.  
 La Crosse Knitting Works, La Crosse, Wis. (K) 281.  
 La Crosse Woolen Mills (R. Blashek) 281.  
 Ladd, Geo. W. & Co., Boston, Mass. (K) 112.  
 Lafayette Carpet Co., Lafayette, Ind. (W) 97.  
 Lafayette Knitting Mill Co., Fayetteville, N. C. (K) 188.  
 Lafayette Mill (Rodman Mfg. Co.) 254.  
 Lafayette Underwear Co., Lafayette, Ind. (K) 97.  
 Lafayette Worsted Co., Woonsocket, R. I. (W) 261.  
 Lafferty Bros., Philadelphia, Pa. (C) 220.  
 Lafferty, John & Bro., Philadelphia, Pa. (D & F) 220.  
 Lafferty, M., Philadelphia, Pa. (W) 220.  
 La Grange Mills, La Grange, Ga. (C) 90.  
 Lake Austin Knitting Mills (R. M. Lewis) 276.  
 Lake Mills Woolen Mill Co., Lake Mills, Iowa (W) 99.  
 Lake Superior Knitting Works, Appleton, Wis. (K) 280.  
 Lakeshore Hosiery Co. (Jacob May & Co.) 270.  
 Lakeside Knitting Co., Elkhart and Michigan City, Ind. (K) 96, 97.  
 Lakeside Mill (Evans, Joseph P.) 151.  
 Lakeside Mills, Burlington, N. C. (C) 185.  
 Lakeside Worsted Mills, Skowhegan, Me. (W) 106.  
 Lakeville Woolen Co., West Rutland, Mass. (W) 123.  
 Lamb Knit Goods Co., Colon, Mich. (K) 137.  
 Lamb Mill (David N. Taft) 128.  
 Lambert, Wm., Reed City, Mich. (W) 138.  
 Lambeth Rope Corp., New Bedford, Mass. (C) 126.  
 Lamolite Mills, Fairfax, Vt. (W) 275.  
 Lamond & Robertson Co., The, Paterson, N. J. (J) 156.  
 Lamy, J. A. Mfg. Co., Sedalia, Mo. (W) 142.  
 Lanark Knitting Co., Philadelphia, Pa. (K) 220.  
 Lancaster Cotton Mills, Lancaster, S. C. (C) 266.  
 Lancaster Mfg. Co., Lancaster, Mass. (C) 121.  
 Lancaster, M. J. Co., Chester, N. J. (W) 149.  
 Lancaster Mills, Clinton, Mass. (C) 114.  
 Lance, Geo. A., Watertown, N. Y. (W) 184.  
 Landenberger, J. W. & Co., Philadelphia, Pa. (K) 220.  
 Landenburg Worsted Mills (Ezra Lund) 239.  
 Lando, Wm. H., Reading, Pa. (K) 245.  
 Lane, E. M. Mrs., Philadelphia, Pa. (K) 230.  
 Lane Mills of New Orleans, New Orleans, La.  
 Lanett Bleaching & Dye Works, West Point, Ga. (B1 & D) 92.  
 Lanett Cotton Mills, West Point, Ga. (C) 92.  
 Lang, John, Langville, Pa. (W) 239.  
 Langdale, Joseph, Highlandville, Mass. (K) 120.  
 Langdell Mill (John B. Sidebotham) 226.  
 Langdell Mills (Wm. P. Troth, Jr. & Co.) 228.  
 Langewald, F. A. W., Monson, Mass. (W) 125.  
 Langley Mfg. Co., Langley, S. C. (C) 266.  
 Langley Mfg. Co., The, West Point, Ga. (C) 92.  
 Lansdowne Mfg. Co., The, Philadelphia, Pa. (W) 220.  
 Lanza Silk Co., Lansdale, Pa. (S) 239.  
 La Porte Woolen Mills (Sam'l Fox's Sons) 97.  
 Lapworth, Wm. & Sons, Milford, Mass. (C) 125.  
 Las Vegas Wool Pulling Co., Las Vegas, New Mexico (W) 160.  
 Latham, Fred, Highlandville, Mass. (K) 120.  
 La Tosca Knitting Co., Utica, N. Y. (K) 182.  
 Lattner, Jacob, Latner's, Iowa (W) 99.  
 Laurel Cotton Mills, Laurel, Miss. (C) 141.  
 Laurel Division, (U. S. Duck Corp.), Laurel, Md. (C) 108.  
 Laurel Hill Yarn Co., Bridgeton, R. I. (W) 251.  
 Laurel Lake Mills, Fall River, Mass. (C) 117.  
 Laurel Mills (J. F. Jones) 191.  
 Laurel Mills Mfg. Co., Roswell, Ga. (W) 91.  
 Laurel Run Mill (A. Sponhauer) 243.  
 Laurel Silk Works, Paterson, N. J. (S) 156.  
 Laurens Cotton Mills, Laurens, S. C. (C) 266.  
 Laurier Sons Silk Co., Taylor, Pa. (S) 248.  
 Lautenbacher, A., Schuylkill Haven, Pa. (K) 246.  
 Laux, J. A., Tremont, Pa. (K) 249.  
 Lavonia Cotton Mills, Lavonia, Ga. (C) 90.  
 Lawlor, Thos. L., Philadelphia, Pa. (C) 220.  
 Lawrence Duck Co., Lawrence, Mass. (C) 122.  
 Lawrence Dye Works Co., The, Lawrence, Mass. (D & F) 122.  
 Lawrence Felting Co., Millville, Mass. (W) 125.  
 Lawrence Knitting Co., Lawrence, Mass. (K) 122.  
 Lawrence Mfg. Co., Lowell, Mass. (C & K) 123.  
 Lawrence, Webster & Co., The, Malone, N. Y. 172.  
 Lawrenceville Mfg. Co., Lawrenceville, Ga. (C) 90. (Also see Too Late Classification List.)  
 Lawson, A. M., New York, N. Y. (K) 178.  
 Lawton Spinning Co., Providence and Woonsocket, R. I. (C) 258, 261.  
 Laycock, John, Philadelphia, Pa. (C) 220.  
 Lazowick, Morris B., Philadelphia, Pa. (K) 220.  
 Lea, Sam'l & Son, Philadelphia, Pa. (F) 220.  
 Leak, W. H. & Co. (Victor Hosiery Mills) 191.  
 Leak, Wall & McRae, Rockingham, N. C. (C) 194.  
 Leaksville Cotton Mills, Spray, N. C. (C) 195.  
 Lakesville Woolen Mill, Spray, N. C. (W) 195.  
 Leary Dyeing & Cleaning Works, Rochester, N. Y. (D) 180.  
 Leary, Ed. B. (Leary Dye & Cleaning Wks) 180.  
 Leavers, Walter & Co., Philadelphia, Pa. (K) 220.  
 Leavitt, H. C. (Leavitt Woolen Mill) 131.  
 Leavitt Woolen Mill, Spencer, Mass. (W) 131. (See also Too Late Classification List.)  
 Lebanon Mill Co., Pawtucket, R. I. (K) 256.  
 Lebanon Mills, Lebanon, N. H. (W) 146.  
 Lebanon Textile Co., Avon, Pa. (K) 233.  
 Lecha Silk Co., Allentown, Pa. (S) 231.  
 Ledbetter Mfg. Co., Rockingham, N. C. (C) 194.  
 Lee, D. M., Uxbridge, Mass. (W) 132.

- Lee Hosiery Mills, Philadelphia, Pa. (K) 220.  
 Lee, J. Ellwood Co., Conshohocken, Pa. (C) 236.  
 Lee, James H., Philadelphia, Pa. (W) 220.  
 Lee, Wm. M., Westminster Depot, Mass. (W) 133.  
 Leedom, Thos. L. & Co., Bristol, Pa. (W) 234.  
 Lees, Daniel, Lenni Mills, Pa. (S & W) 240.  
 Lees, James & Sons Co., Bridgeport, Pa. (W) 234.  
 Lees Mfg. Co., Westport, Conn. (C) 81.  
 Lees, W. H., Agt. (Dover Mill) 213.  
 Lehigh Dye Works (Franz Schanz) 225.  
 Lehigh Knitting Mills, Allentown, Pa. (K) 231.  
 Lehigh Mfg. Co., Philadelphia, Pa. (C) 220.  
 Lehigh Steam Bleachery, So. Bethlehem, Pa. (Bl) 248.  
 Lehigh Valley Silk Mills, So. Bethlehem, Pa. (S) 248.  
 Leib & Miller, Pottsville, Pa. (S) 244.  
 Leicester Knitting Mill, Woonsocket, R. I. (K) 261.  
 Leicester & Continental Mills Co., The, Philadelphia, Pa. (W & K) 220.  
 Leimbach, J. G. & Co., Reading, Pa. (W) 245.  
 Leimbach Woolen Co., Antes Fort, Pa. (W) 233.  
 Leimbach & High, Robeson, Pa. (K) 246.  
 Leininger, Wm. G., Mohn's Store, Pa. (K) 241.  
 Leininger, Louis, Philadelphia, Pa. (W) 220.  
 Leiter, I. H., New York, N. Y. (S) 176.  
 Leithead, R. S. & Sons, Philadelphia, Pa. (D) 220.  
 Leithold, Max (Philadelphia Hosiery Finishing Works) 224.  
 Le Mars Dye Works (L. H. Mathwig) 99.  
 Lenoir Cotton Mill, Lenoir, N. C. (C) 191.  
 Lenox Mills (Kneedler & Co.) 219.  
 Lenz, J. F., Wilmot, O. (W) 201.  
 Leominster Worsted Co., Leominster, Mass. (W) 122.  
 Leon, Henry, Bradford, Pa. (S) 234.  
 Leonard Mill, Deposit, N. Y. (S). See Too Late Classification List.  
 Leone & Fimpel, New York, N. Y. (S) 176.  
 Le Retiley, T., Roscoe, O. (K) 200.  
 Lessig, A. & A., Philadelphia, Pa. (C) 220.  
 Levitt Carpet Co., Carlisle, Pa. (W & J) 234.  
 Levi Cotton Mills Co., Rutherfordton, N. C. (C) 194.  
 Levinson, D., Appleton, Wis. (W) 250.  
 Levy, A. & M., Paterson, N. J. (S) 156.  
 Levy, E. & H., New York, N. Y. (S) 176.  
 Levy, Stiefel Co., New York, N. Y. (K) 176.  
 Lewis Batting Co., Walpole, Mass. (C) 132.  
 Lewis, Bradford & Son, Walpole, Mass. (C) 132.  
 Lewis, E. Frank, Lawrence, Mass. (W) 122.  
 Lewis, James B., Walpole, Mass. (C) (See Too Late Classification List.)  
 Lewis, J. D. & Sons, Minersville, Pa. (K) 241.  
 Lewis, J. Wm. & Co., Chester, Pa. (C) 235.  
 Lewis Knitting Co., Sauquoit, N. Y. (K) 180.  
 Lewis Knitting Co., Janesville, Wis. (K) 281.  
 Lewis, N. & N. R., Fall River, Mass. (C) 117.  
 Lewis, Robt., Philadelphia, Pa. (C & S) 220.  
 Lewis, R. M., Wells, Vt. (K) 276.  
 Lewisburg Woolen Co., Lewisburg, Pa. (W) 240.  
 Lewiston Bleachery & Dye Works, Lewiston, Me. (Bl & D) 105.  
 Lewistown Knitting Mill, Lewistown, Pa. (K) 240.  
 Lexington Cotton Mills, Lexington, Miss. (C) 111.  
 Lexington Mfg. Co., Lexington, S. C. (C) 266.  
 Lexington Woolen Mills, Lexington, Mich. (W & K) 138.  
 Libbey & Dingley Co., Lewiston, Me. (C & W) 105.  
 Libbey & Henderson (Cobbseecentee Wln. Co.) 103.  
 Liberty Cotton Mills, Liberty, S. C. (C) 266.  
 Liberty Dye Works, Reading, Pa. (D & Pr) 245.  
 Liberty Hosiery Mills (Rosenau & Loeb) 225.  
 Liberty Knitting Mills, Brooklyn, N. Y. (K) 165.  
 Liberty Silk Co., Hornellsville and New York, N. Y. (S) 170, 176.  
 Liberty Silk Dyeing Co., Paterson, N. J. (S) 156.  
 Liberty & Harmony Mills (Travers Bros. Co.) 177.  
 Lick Woolen Mfg. Co., San Francisco, Cal. (W) 72.  
 Little Knitting Co., Amsterdam, N. Y. (K) 161.  
 Liebhart Bros., Middletown, Ind. (W) 97.  
 Light & Bomberger, Avon, Pa. (K) 233.  
 Lillie, Dexter, P. & Co., Indian Orchard, Mass. (C) 121.  
 Lily Mills, Spray, N. C. (C) 195.  
 Limerick Mills, Limerick, Me. (W) 105.  
 Limestone Hosiery Co., Athens, Ala. (K) 67.  
 Limestone Mfg. Co., Gaffney, S. C. (C) 265.  
 Lincoln Cotton Mills, Lincolnton, N. C. (C) 192.  
 Lincoln Mfg. Co., Chester, Pa. (C) 225.  
 Lincoln Mills (Libbey & Dingley Co.) 105.  
 Lincoln Mills (The Krook & Bruch Co., Ltd.) 220.  
 Lincoln Silk Co., Paterson, N. J. (S) 156.  
 Lindale Knitting Mill, Lindale, Texas (K) 272.  
 Linden Mfg. Co., Davidson, N. C. (C) 188.  
 Linden Worsted Mills, Camden, N. J. (W) 149.  
 Lindenwald Mills (C. F. Hoag) 179.  
 Lindner, Hugo, Newark, N. J. (K) 152.  
 Linen Mfg. Co., The, Paris, Me. (Fl) 106.  
 Linen Underwear Co., New Britain, Conn. (K) 77.  
 Linn Mills Co., China Grove, N. C. (C) 187.  
 Linn, Wm., Jr., Freedom, Me. (W) 103.  
 Linn Woolen Co., Hartland, Me. (W) 103.  
 Linton, Horace & Bros., Philadelphia, Pa. (C & S) 220.  
 Linwood Cotton Mill, Whitinsville, Mass. (C) 134.  
 Lion Mfg. Co., St. Johnsville, N. Y. (K) 181.  
 Lion Mill (Hoffman Corr Mfg. Co.) 217.  
 Lion Silk Co., New York, N. Y. (S) 176.  
 Liondale Bleach. Dye & Print Works, Rockaway, N. J. (Bl, D & Pr) 159.  
 Lippard Yarn Mill, Concord, N. C. (C) 187.  
 Lippitt Mills, Phenix, R. I. (C) 257.  
 Lippitt Woolen Co., Woonsocket, R. I. (W) 261.  
 Lippmann, Israel, New York, N. Y. (K) 176.  
 Lips, Joseph W. & Co., New York, N. Y. (D. & F) 176.  
 Liston, Jesse, Listonburg, Pa. (W) 240.  
 Litchfield Woolen Mills, Litchfield, Minn. (W & K) 139.  
 Little Androsoggin Water Power Co. (Barker Mill) 102.  
 Little Falls Mills (Stafford & Co.) 227.  
 Little Falls Wool Extract Co., Little Falls, N. Y. (W) 171.  
 Little, W. & Co., Paterson, N. J. (S) 156.  
 Littlefield Mfg. Co., Pawtucket, R. I. (C) 256.  
 Littleton Hosiery Mills, Littleton, N. C. (K) 192.  
 Littlewood, G. J. & Sons, Ltd., Philadelphia, Pa. (D) 220.  
 Littmann, I., Salisbury, N. C. (C) 194.  
 Livingston, Jas. & Co., Yale, Mich. (Fl) 139.  
 Livingstone Woolen Mills, Washington, R. I. (W) 260.  
 Lloyd, Thomas F., Chapel Hill, N. C. (C) 185.  
 Lloyd, Wm. S. (Stratford Knitting Mills) 227.  
 Lobsutz, Samuel, Nutley, N. J. (W) 153.  
 Lock City Lamb's Wool Batting Co., Lockport, N. Y. (W) 171.  
 Lockhart, Isaac, Philadelphia, Pa. (W) 220.  
 Lockhart Mills, Lockhart, S. C. (C) 266.  
 Lockhart, Wm., Philadelphia, Pa. (W) 220.  
 Lock Haven Silk Co., Lock Haven, Pa. (S) 240.  
 Lockman, Richard & Son, Paterson, N. J. (S) 156.  
 Lockport Cotton Batting Co., (E. W. Rogers & Sons) 171.  
 Lockport Felt Co., Newfane, N. Y. (W) 173.  
 Lockwood Co., Waterville, Maine (C) 197.  
 Lockwood, L. A. Co., Saylesville, R. I. (C) 259.  
 Locustville Mill (Nichols & Langworthy Machine Co.) 254.  
 Lodge, John F. & Sons, Philadelphia, Pa. (W) 220.  
 Lodi Dry Dyeing Co., Passaic, N. J. (D) 153.  
 Loeb, Lipper & Co., Philadelphia, Pa. (S) 220.  
 Loebenblum, L., Amsterdam, N. Y. (K) 161.  
 Loewenstein, J. H., New York, N. Y. (K) 175.  
 Logan Knitting Factory, Logan, Utah (K) 273.  
 Lomas, W. A., Colebrook, N. H. (W) 143.  
 Lomax, Joseph, Philadelphia, Pa. (W) 220.  
 Lombaerde, Charles, Paterson, N. J. (S) 156.  
 London Knitting Mills, Brooklyn, N. Y. (K) 165.  
 Long Bros. Co., The, Philadelphia, Pa. (W) 220.  
 Long Island Braid Co., Corona, N. Y. (C & W) 168.

- Long Island Cotton Mills, Long Island, N. C. (C) 192.
- Long Shoals Cotton Mills, Long Shoals, N. C. (C) 192.
- Long, S. M., Manheim, Pa. (K) 240.
- Longbottom, S. & Sons, Crum Lynne, Pa. (W) 236.
- Lonsdale Co., Ashton and Lonsdale, R. I. (C) 251, 254.
- Lonsdale's, John, Sons, Dale, Iowa (W) 98.
- Loose, James K., Reading Pa. (K) 245.
- Loray Mills, Gastonia, N. C. (C) 189.
- Lord Bros., Philadelphia, Pa. (W) 221.
- Lord, John, Sons, Philadelphia, Pa. (W) 221.
- Lord, R. W. & Co., Kennebunk, Maine (C) 163.
- Lorenz, Richard, Chicago, Ill. (K) 93.
- Loridan Worsted Co., Woonsocket, R. I. (W) 261.
- Lorimer's, W. H., Sons Co., Philadelphia, Pa. (D) 221.
- Lorio, Jacob, Dedman, Mass. (K) 115.
- Lorraine Mfg. Co., Pawtucket, Westerly, R. I. (C & W) 256, 260.
- Los Angeles Woolen Mills, Los Angeles, Cal. (W) 71.
- Loth, Jos. & Co., New York, N. Y. (S) 176.
- Lotte & Mazeres Co., The, Allentown, Pa. (D) 231.
- Loud, D. A. & Co. (Phoenix Woolen Mills) 100.
- Loughridge, W. J., Lexington, Ky. (Fl.) 100.
- Louise Mills, Charlotte, N. C. (C) 185.
- Louisiana Silk Co., Paterson, N. J. (S) 156.
- Louisville Cotton Mills Co., Louisville, Ky. (C) 101.
- Louisville Girth and Blanket Mills, Louisville, Ky. (W) 101.
- Louisville Woolen Mills, Louisville, Ky. (W) 101.
- Lounsbury & Bissell Co., The, Winnepauk, Conn. (W) 83.
- Love, Henry M., Wilmington, Del. (K) 84.
- Love, Robert, Paterson, N. J. (S) 156.
- Lovestein, Robert, (Kingsboro Dye Works) 169.
- Lowd, Percy, J., Philadelphia, Pa. (K) 221.
- Lowe Mfg. Co., Huntsville, Ala. (C) 69.
- Lowell Bleachery, Lowell, Mass. (B1 & D) 123.
- Lowell Cotton Mills, Lowell, N. C. (C) 192.
- Lowell Hosiery Co., Lowell, Mass. (K, D & B) 123.
- Lowell Textile Co., Lowell, Mass. (C & F) 123.
- Lowell Textile School, Lowell, Mass. (C W & D) 123.
- Lowell Waste Co., Lowell, Mass. (C) 123.
- Lowell Weaving Co., Lowell, Mass. (C) 123.
- Lowenthal, Max & Bro., Rochester, N. Y. (K) 180.
- Lowenthal, Wm. & Co., Boston, Mass. and Cohoes, N. Y. (W & C) 112, 167.
- Lowndes, R. T. (Clarksburg Woolen Mill) 279.
- Loyal Silk Co., Paterson, N. J. (S) 156.
- Lucas, Benj. & Co., Norwich, Conn. (W) 78.
- Lucas & Co., Paterson, N. J. (S) 156.
- Ludermann Wool Co., Las Vegas, N. Mex. (W) 160.
- Ludlow Cordage Co., Ludlow, Mass. (J) 124.
- Ludlow Mfg. Co., Ludlow, Mass. (J) 124.
- Ludlow Woolen Mills, Ludlow, Vt. (W) 275.
- Ludwig, Edward & Son, Philadelphia, Pa. (W) 221.
- Ludwig, J. & Sons (Ebensburg Woolen Mill) 237.
- Ludwig Mfg. Co., Jersey City, N. J. (S) 151.
- Luthien, I. B., Philadelphia, Pa. (D) 221.
- Luke Ktg. Co., Portland, Oregon (K) 201.
- Lull Bros., Philadelphia, Pa. (S) 221.
- Lulu Mfg. Co., King's Mountain, N. C. (K) 191.
- Lumb, Geo. H., Pawtucket, R. I. (K) 256.
- Lumberton Cotton Mills, Lumberton, N. C. (C) 192.
- Lund, Ezra, Landenburg, Pa. (W) 239.
- Lunstras Dyeing & Cleaning Co., St. Louis, Mo. (D & F) 142.
- Lunn, John Co., Camden, N. J. (W) 149.
- Lupprian, Chas., New York, N. Y. (K) 176.
- Lupton, Oliver & Co., Philadelphia, Pa. (W) 221.
- Lura Knitting Mill, Shelby, N. C. (K) 195.
- Lutz, David T., Lutzville, Pa. (W) 240.
- Luzerne Knitting Mill, Pittston, Pa. (K) 243.
- Lycoming Silk Mills (Holmes Silk Co.) 250.
- Lydia Cotton Mills, Clinton, S. C. (C) 263.
- Lyle, John, Salt Lake City, Utah (S) 273.
- Lyle, P. T. (Kensington Skein Silk Dye Works) 219.
- Lyman Mills, Holyoke, Mass. (C) 120.
- Lymansville Co., Lymansville, R. I. (W) 254.
- Lynch Scotch Cap Co., Utica, N. Y. (K) 182.
- Lynchburg Cotton Mill Co., Lynchburg, Va. (C) 277.
- Lynchburg Hosiery Co., Lynchburg, Va. (K) 277.
- Lyons, S. C. & Bros., Bennington, Vt. (K) 273.
- Lytle, John T., Fredericksburg, O. (W) 199.
- McAden Mills, McAdenville, N. C. (C) 192.
- McAnespie, James & Co., Lancaster, O. (W) 199.
- McArthur, Geo. & Son, Baraboo, Wis. (C) 280.
- McCallum Hosiery Co., Northampton, Mass. (K) 127.
- McCauley, T., Philadelphia, Pa. (D) 221.
- McCleary, Wallin & Crouse (Mohawk Mills) 161.
- McClosky, James, Philadelphia, Pa. (B) 221.
- McColl Mfg. Co., McColl, S. C. (C) 266.
- McComb City Cotton Mills, McComb City, Miss. (C) 141.
- McComesky, Thos., Philadelphia, Pa. (J) 221.
- McConnell, J. S. Wool Co., Mt. Vernon, O. (W) 200.
- McCord, L. A., Laurens, S. C. (C) 266.
- McCormick Harvesting Machine Co., Chicago, Ill. (C) 93.
- McCowan, John, New York, N. Y. (Pr) 176.
- McCowan, John (American Novelty Printing and Embossing Works) 173.
- McCracken, R. W. & J. D. Adairville, Ky. (W) 160.
- McCulloch, Robt., Paterson, N. J. (S) 157.
- McDougal, John W., New York, N. Y. (D) 176.
- McDowell Bros., Philadelphia, Pa. (W) 221.
- McDowell, David, Philadelphia, Pa. (W) 221.
- McDowell, G. H. & Co., Cohoes, N. Y. (K) 167.
- McElroy, Frank T. (Steelton Hosiery Mills) 248.
- McElroy, W. A. (Sterling Carpet Mills) 227.
- McFarlan & Co., Amsterdam, N. Y. (K) 161.
- McFarland Co., Geo., West Conshohocken, Pa. (W) 249.
- McFetridge, E. P. & W. H. (Island Woolen Co.) 250.
- McGann, O. W., Rutland, Mass. (W) 130.
- McGill & Co., Philadelphia, Pa. (W) 221.
- McGinley & Klenk, Philadelphia, Pa. (W) 221.
- McGinnis, M. J. & Co., Philadelphia, Pa. (C) 221.
- McGregor, Walter, Philadelphia, Pa. (C) 221.
- McGraw, B. F., Pulaski, Tenn. (C) 271.
- McGuire, F. S. Co., Ltd., Ogdensburg, N. Y. (W) 178.
- McIlwain & Co., Philadelphia, Pa. (S) 221.
- McIntyre, Mrs. Wm., Carrollton, Mo. (W) 141.
- McKaig & Pulster, Philadelphia, Pa. (K) 221.
- McKeage, Samuel (Delwood Mill) 211.
- McKechnie, James, Philadelphia, Pa. (C) 221.
- McLaren, J. & R., West Sand Lake, N. Y. (K) 184.
- McLeublin, Jas. C., Roseberg, Pa. (W) 246.
- McLean, A. Co., Passiac, N. J. (C) 153.
- McLean & McMurdy (Buena Vista Woolen Mills) 276.
- McMann, W. G., Philadelphia, Pa. (K) 221.
- McMannus, Peter B. (Home Bleach & Dye Works) 255.
- McNair, Thos., Philadelphia, Pa. (W) 221.
- McPherson, Sam'l, Philadelphia, Pa. (C) 221.
- McTavish & Cullis (Soo Woolen Mill) 139.
- Mabbett, Geo. & Sons, Plymouth, Mass. (W) 129.
- MacElroy, Archibald C., Mfg. Co., Beverly, N. J. (C) 148.
- MacFarlane, J. S., Atwoolville and Mansfield Centre, Conn. (S) 72, 76.
- McGowan, Jr., Jas. C. (Oriental Silk Thread Co.) 129.
- MacKinnon, Robt., Little Falls, N. Y. (K & C) 171.
- Mack, Everett & Co., Herkimer, N. Y. (K) 170.
- Mack Silk Co., Jos. S., The, Allentown and Scranton, Pa. (S) 231, 247.



- Mackay & Rowson, Paterson, N. J. (S) 156.  
 Mackenzie, F. S., Bridgewater, Vt. (W) 275.  
 Macintosh, D. & Sons Co., Holyoke, Mass. (D) 120.  
 Macon Knitting Co., Macon, Ga. (K) 90.  
 Madocra & Wanner, Lyon Station, Ba. (K) 240.  
 Madison County Spinning Co., Huntsville, Ala. (C) 69.  
 Madison Woolen Co., Madison, Maine (W) 105.  
 Madison Woolen Mills (H. T. Berry) 276.  
 Madisonville Woolen Mills Co., Madisonville, O. (W) 199.  
 Madrid Woolen Mills, Madrid, N. Y. (W) 172.  
 Magee Carpet Works, The, Ltd., Bloomsburg, Pa. (W) 233.  
 Magill, S. A. (Atlanta Hosiery Mill) 85.  
 Maginnis Cotton Mills, New Orleans, La. (C) 102.  
 Magnolia Cotton Mills, Magnolia, Miss. (C). See Too Late Classification List.  
 Magnolia Mills, Charlotte, N. C. (C) 185.  
 Magrann, E., Philadelphia, Pa. (C) 221.  
 Magrath, Ammann & Arnold Co., Paterson, N. J. (D) 156.  
 Maguire, Wm. J., Camden, N. J. (S) 149.  
 Maheffy Bros., Pulaski, N. Y. (W) 179.  
 Maiden Cotton Mills, Malden, N. C. (C) 192.  
 Maiden Creek Hosiery Co., Maiden Creek, Penn. (K) 240.  
 Maine Alpaca Co., Springvale, Me. (W) 107.  
 Maish, Chas. A. & Co., Cincinnati, O. (C) 198.  
 Majestic Velvet Mills, Hoboken, N. J. (S) 151.  
 Malcolm Knitting Co., Catskill, N. Y. (C) 166.  
 Malcolm Mills Co., Philadelphia, Pa. (S & W) 221.  
 Mallison Braided Cord Co., Athens, Ga. (C) 85.  
 Mellison Rope Walk (John M. Hudson) 217.  
 Malone Woolen Mills, Malone, N. Y. (W) 172.  
 Mammoth Spring Cotton Mills, Mammoth Spring, Ark. (C) 71.  
 Manantico Bleach & Dye Works (Millville Mfg. Co.) 152.  
 Manayunk Finishing Works (Geo. W. Peterson, agt.) 224.  
 Manchaug Co., Manchaug, Mass. (C) 124.  
 Manchester Cotton Mills, Rock Hill, S. C. (C) 267.  
 Manchester Finishing Works, Philadelphia, Pa. (P) 221.  
 Manchester Mfg. Co., Macon, Ga. (C) 90.  
 Manchester Mills, Manchester, N. H. (C, W, Pr & D) 146.  
 Manchester Stocking Co., Manchester, N. H. (K) 146.  
 Manchester Woolen Mills, Manchester, Iowa (W) 99.  
 Mandel, George, West Hoboken, N. J. (C, W & S.) 160.  
 Mandeville Cotton Mills, Carrollton, Ga. (C) 86.  
 Manetta Mills, Lando, S. C. (C) 266.  
 Manhatta Backing Co., New York, N. Y. (C & S) 176.  
 Manhattan Braid Works, Harrison, N. Y. (C & S) 170.  
 Manhattan Cloth Sponging and Refinishing Works (John W. Fleck) 174.  
 Manhattan Ktg. Mills (Israel Lippmann) 176.  
 Manhattan Mill (John Culbertson & Sons) 211.  
 Manhattan Print Works, Passaic, N. J. (Pr & D) 152.  
 Manhattan Silk Co., Paterson, N. J. (S) 156.  
 Manhattan Worsted Mills, New York, N. Y. (W) 176.  
 Manheim Hosiery Mills (S. M. Long) 240.  
 Mankato Mills Co., Mankato, Minn. (K) 139.  
 Mann & Stevens Woolen Co., East Brookfield, Mass. (W) 115.  
 Mansfield Elastic Web Co., Mansfield, O. (C) 199.  
 Mansfield, G. H. & Co., Canton, Mass. (S) 113.  
 Mansfield, I. T. & Son, Franklin, Ill. (W) 95.  
 Mansfield, Joseph W., Philadelphia, Pa. (K) 221.  
 Mansfield Print Works, Malden, Mass. (Pr) 124.  
 Mansfield Woolen Co., Mansfield, Pa. (W) 240.  
 Mansure, E. L. Co., Chicago, Ill. (S) 93.  
 Manton Mills, Manton, R. I. (W) 254.  
 Manville Co., Manville and Woonsocket, R. I. (C) 254, 261.  
 Maple City Knitting Mills, Honesdale, Penn. (K) 229.  
 Maple Grove Warp Mills (Adams Bros. Mfg. Co.) 109.  
 Maplewood Mills, Fall River, Mass. (C) 117.  
 Marble City Hosiery Mill (T. J. Mathews) 70.  
 Marble, E. M. & Co., Chicago, Ill. (K) 93.  
 Marble Knitting Mills, The, Releigh, N. Y. (K) 179.  
 Marble, L. D. & Son, Hickox, Penn. (W) 239.  
 March, Alfred & Co., New Brunswick, N. J. (K) 153.  
 Marcus, M. H. & Bro., Walpole, Mass. (C) 132.  
 Marcy, Harry W., Providence, R. I. (C) 258.  
 Margerison, W. H. & A. E. Co., Philadelphia, Pa. (C) 221.  
 Margolius & Co., Charlotte, N. C. (J) 185.  
 Marie Mills, McColl, S. C. (C) 266.  
 Mariette Knitting Co., Marietta, Ga. (K) 90.  
 Marion Hosiery Mills, Philadelphia, Pa. (K) 221.  
 Mark Mfg. Co., Herkimer, N. Y. (K) 170.  
 Markland & Roessler, Swedeland, Pa. (W) 248.  
 Marland Mills, Andover, Mass. (W) 111.  
 Marlboro Mills (John E. Hanifen & Co.) 217.  
 Marshall & Co. (Shrewsbury Mills) 152.  
 Marston Woolen Co., Skowhegan, Me. (W) 106.  
 Martin, A. B. & Thomas (Mansfield Elastic Web Co.) 199.  
 Martin, Chas. N. Co., New York, N. Y. (S) 176.  
 Martin, Jas. & Co., Philadelphia, Pa. (D & Pr) 221.  
 Martin, James A., Callaway, Va. (W) 276.  
 Martin, J. B. & Co., Ltd., Norwich, Conn. (S) 78.  
 Martin, T. and Bro. Mfg. Co., Chelsea, Mass. (C) 114.  
 Martin, Thos. & Co., New York, N. Y. (S) 176.  
 Martin, Wm. and Sons, Chelsea, Mass. (C) 114.  
 Martin & Co., Philadelphia, Pa. (P) 221.  
 Martin & Gaw, Philadelphia, Pa. (W) 221.  
 Martin & Marble, West Buxton, Maine, (W) 107.  
 Martin's, E. Sons, Rockville, Conn. (S) 79.  
 Martinsburg Worsted & Cassimere Co., Martinsburg, W. Va. (W) 279.  
 Marvin & Pardee (Globe Silk Works) 77.  
 Mary Leha Cotton Mill, Greensboro, Ga. (C) 89.  
 Mary Louise Mills, Cowpens, S. C. (C) 263.  
 Maryland Bleach and Dye Works, Baltimore, Md. (Bl & D) 108.  
 Maryland Woolen Co., Baltimore, Md. (W) 108.  
 Marysville Woolen Mills, Marysville, Cal. (W) 71.  
 Mascot Hosiery Co., Philadelphia, Pa. (K) 221.  
 Masont Knitting Mills, Sweetwater, Tenn. (K) 271.  
 Mashentuck Mills, Killingly, Conn. (W) 76.  
 Masland, C. H. & Sons, Philadelphia, Pa. (D & W) 221.  
 Masland, Joseph H. Co., Philadelphia, Pa. (C & K) 221.  
 Masland, J. W. & Co., Philadelphia, Pa. (D) 222.  
 Mason, Geo., Woonsocket, R. I. (C & W) 261.  
 Mason, Robt. D. Co., The, Pawtucket, R. I. (D & Bl) 256.  
 Mason Silk Mills, The, Paterson, N. J. (S) 157.  
 Mason, W. H., Providence, R. I. (C) 258.  
 Massachusetts Cotton Mills, Lowell, Mass. (C) 123.  
 Massachusetts Mills in Georgia, Lindale, Ga. and Lowell, Mass. (C) 90, 123 (also see too late classification list)  
 Massachusetts Mohair Plush Co., Lowell, Mass. (W) 123.  
 Massachusetts Reformatory, Concord Junction, Mass. (C & W) 115.  
 Massachusetts State Prison, Boston, Mass. (C) 112.  
 Massachusetts Yarn Mills, Shattuckville, Mass. (C) 120.  
 Massasolet Ktg. Mills, Waterford, N. Y. (K) 183.  
 Massasolet Mfg. Co., Fall River, Mass., and Oakdale, Conn. (C) 78, 117.  
 Massasolet Woolen Mills, Huntington, Mass. (W) 121.  
 Massey, J. A. (Northfield Knitting Co.) 140.  
 Mathes Bros., Philadelphia, Pa. (D) 222.  
 Mathews, T. J., Sylacauga, Ala. (K) 70.  
 Mathwig, L. H., Lemars, Iowa (D) 99.  
 Matoaca Mfg. Co., Petersburg, Va. (C) 277.  
 Matred Mills, Philadelphia, Pa. (S) 222.

- Matteawan Mfg. Co., Matteawan, N. Y. (W) 172.  
 Maul, H. & Co., New York, N. Y. (S) 175.  
 Maupai, F. R., New York, N. Y. (D) 176.  
 Maurer, T. W. & Sons, Philadelphia, Pa. (S) 222.  
 Mauston Woolen Mills, Mauston, Wis. (W & K) 281.  
 Mawby, J. V., Philadelphia, Pa. (W) 222.  
 Mawson, John, Hair Cloth Co., Philadelphia, Pa. (C & W) 222.  
 Maxton Cotton Mills, Maxton, N. C. (C) 192.  
 Maxwell Throwing Co., Jermyn, Pa. (S) 239.  
 May, Jacob & Co., Nashville, Tenn. (K) 270.  
 Maybaum & Co., Philadelphia, Pa. (K) 222.  
 Mayer, W. H., New York, N. Y. (D) 176.  
 Mayfield Knitting Mills, Mayfield, Ky. (K) 101.  
 Mayfield Woolen Mills Clo. Co., Louisville, Ky. (W) 101.  
 Mayhew Silk Co., Paterson, N. J. and Altoona, Pa. (S) 157, 231.  
 Mayo Mills, Mayodan, N. C. (C) 192.  
 Mayo Woolen Co., Millbury, Mass. (W) 125.  
 Mayo & Son, Foxcroft, Maine (W) 103.  
 May's Landing Water Power Co., May's Landing, N. J. (C) 152.  
 Maysville Cotton Mills (January & Wood Co.) 101.  
 Meadow Spring Dye & Print Works (Chas. Wilson's Sons) 270.  
 Meadowbrook Mills, Falconer, N. Y. (W) 169.  
 Meadville Silk Mfg. Co., Meadville, Pa. (S) 240.  
 Meagher, Jas., Sons, San Francisco, Cal. (J) 72.  
 Mears, Henry W., Essex, Mass. (C) 116.  
 Mechanics' Mills, Fall River, Mass. (C) 117.  
 Mechanicville Knitting Co., Mechanicville, N. Y. (K) 172.  
 Meek & Coldren, Schuylkill Haven, Pa. (K) 246.  
 Medczer Bros., Hawley, Pa. (S) 238.  
 Medford Woolen Mfg. Co., Medford, Mass. (W) 124.  
 Meding Mfg. Co., Paterson, N. J. (S) 157.  
 Medlicott Co., Windsor Locks, Conn. (K) 83.  
 Medlicott, Morgan Co., Springfield, Mass. (K) 131.  
 Meek Bros., Bonaparte, Iowa (W) 98.  
 Megowan, Robt., Philadelphia, Pa. (W & C) 222.  
 Megunticook Woolen Co., Camden, Me. (W) 102.  
 Meier, Frank, West Hoboken, N. J. (D) 160.  
 Meinhardt's, O. J., Sons, Philadelphia, Pa. (D) 222.  
 Meleher, Wm. C. (Fidelity Finishing Works) 215.  
 Mellor, Abraham, Chepachet, R. I. (W) 253.  
 Mellor, R. & Co., Philadelphia, Pa. (C) 222.  
 Mellor, Samuel (Stone Worsted Mill) 255.  
 Melrose Knitting Mills, Raleigh, N. C. (K) 193.  
 Melville Woolen Co., Fredericksburg, Va. (W) 276.  
 Memphis Cotton Mill Co., Memphis, Tenn. (C) 270.  
 Menard Street Mill (St. Louis Cordage Co.) 112.  
 Mendelsohn & Goldstein, New York, N. Y. (S) 176.  
 Mendelson, Herman, Brooklyn, N. Y. (K) 165.  
 Mendon Woolen Mills, Mendon, Mass. (W) 124.  
 Menton Knitting Mills Co., The, Menton, O. (K) 199.  
 Mercer Mills, Mercer, Mo. (W) 142.  
 Merchants Dye Works, Dedham, Mass. (D) 115.  
 Merchants Dyeing Co., Chicago, Ill. (D) 93.  
 Merchants Mfg. Co., Fall River, Mass. (C) 117.  
 Merchants Print Works, New York, N. Y. (Pr) 176.  
 Merchant's Woolen Mill, Dedham, Mass. (W) 115.  
 Mercury Mills, Philadelphia, Pa. (C) 222.  
 Meredith, Samuel, Paterson, N. J. (S) 157.  
 Meriden Curtain Fixture Co., Meriden, Conn. (C) 76.  
 Meriden Woolen Mill (Rawitser & Bro.) 76.  
 Meridian Cotton Mills, Meridian, Miss. (C) 141.  
 Meridian Mattress Factory, Meridian, Miss. (C) 141.  
 Merino Mills (Joslin Mfg. Co.) 258.  
 Merion Worsted Mills, West Conshohocken, Pa. (W) 249.  
 Merkle, D. C., Philadelphia, Pa. (S) 222.  
 Merick Thread Co., Holyoke, Mass. (C) 121.  
 Merrill, Field & Co., Hornellsville, N. Y. (S) 170.  
 Merrill, J. F., Boston, Mass. (C) 112.  
 Merrimac Hat Co., Amesbury, Mass. (W) 111.  
 Merrimack Mfg. Co., Huntsville, Ala., and Lowell, Mass. (C & Pr) 69, 123.  
 Merrimack Woolen Co., Lowell, Mass. (W) 123.  
 Merritt, Geo. & Co., Indianapolis, Ind. (W) 97.  
 Merritt Woolen Co., Webster, Mass. (W) See Too Late Classification List.  
 Merz & Bruhm, Philadelphia, Pa. (W) 222.  
 Messenger, A. W., Howard City, Mich. (W) 138.  
 Metacomet Mfg. Co., Fall River, Mass. (C) 117.  
 Meteor Silk Co., Paterson, N. J. (S) 157.  
 Methuen Company, Methuen, Mass. (K) 125.  
 Methuen Hat Co., Methuen, Mass. (W) 125.  
 Methuen Yarn Mill (John W. Jowett) 125.  
 Metropolitan Dye Works (Weigle & Finke) 178.  
 Metstein & Vener (Columbia Knitting Mill Co.) 171.  
 Metz, M. A. & Bro., Philadelphia, Pa. (K) 222.  
 Metzger, Louis & Co., New York, N. Y. (S) 176.  
 Meyer, F., Paterson, N. J. (S) 157.  
 Meyer, H. H., Philadelphia, Pa. (W) 222.  
 Meyer, Martin & Co., New York, N. Y. (S) 176.  
 Meyer Thread Co., Salem Depot, N. H. (C & S) 147.  
 Meyers, Henry & Co. (Union Upholstery Trimming Co.) 177.  
 Miami Valley Knitting Mill (Henry Neiderauer) 199.  
 Miami Woolen Mills, Hamilton, O. (W) 199.  
 Miamisburg Twine & Cordage Co., Miamisburg, O. (Fl) 199.  
 Mianus Mfg. Co., Stamford, Conn. (W) 80.  
 Michaud, Jas. W., Brunswick, Me. (K) 102.  
 Michigan Central Woolen Co., Centreville, Mich. (K) 137.  
 Michigan Knitting Co., Lansing, Mich. (K) 138.  
 Mickle & Cheney, Mechanicsburg, O. (W) 199.  
 Middle Georgia Cotton Mills, Eatonton, Ga. (C) 88.  
 Middleburg Mills, Batesburg, S. C. (C) 262.  
 Middlesex Bleach, Dye & Print Works, Somerville, Mass. (Bl, Pr & D) 130.  
 Middlesex Co., Lowell, Mass. (W) 123.  
 Middlesex Knitting Co., Martinsburg, W. Va. (K) 279.  
 Middlesex Knitting Mills, Camillus, N. Y. (K) 166.  
 Middleton Bros., Quitman, Ark. (W) 71.  
 Midland Hosiery Co., Lynchburg, Va. (K) 277.  
 Midland Hosiery Mill (John Hayes & Co.) 179.  
 Midway Mills (Leak, Wall & McRae) 194.  
 Miesch Mills, Paterson, N. J. (S) 157.  
 Mlessner Bros. Co., The, Huntingburg, Ind. (W) 97.  
 Migel, M. C. & Co., Baltimore, Md., and Astoria, N. Y. (S) 108, 163.  
 Milan Knitting Mill (John Brown) 199.  
 Milford Hosiery Co., Milford Mills, Pa. (K) 241.  
 Millbank Bleach & Dye Works, Pompton Lakes, N. J. (Bl & D) 158.  
 Millbury Cotton Mills, Millbury, Mass. (C) 125.  
 Millen Cotton Mill, Millen, Ga. (C) 90.  
 Miller, Alexander, Providence, R. I. (S) 258.  
 Miller, A. H., Boston, Mass. (W) 112.  
 Miller Bros., Philadelphia, Pa. (K) 222.  
 Miller, Guy H., Herkimer, N. Y. (K) 170.  
 Miller, Jacob, Sons & Co., Philadelphia, Pa. (C & W) 222.  
 Miller, John R. & Co., Reading, Pa. (W) 245.  
 Miller, M. (Fashion Knitting Co.) 174.  
 Miller, Nathan, Philadelphia, Pa. (W) 222.  
 Miller, R. H. & Son, Palmyra, Pa. (K) 243.  
 Miller River Mfg. Co., Athol, Mass. (W) 111.  
 Miller, S. S., Reading, Pa. (K) 245.  
 Miller & Balthaser, Leesport, Pa. (K) 240.  
 Miller & Sons, Philadelphia, Pa. (K) 222.  
 Miller & Ward Co., Paterson, N. J., and Lebanon, Pa. (S) 157, 240.  
 Millfort Mill Co., Fort Mill, S. C. (C) 265.  
 Mills, James, Paterson, N. J. (S) 157.  
 Mills, Jas. & Geo., Pickering, Pa. (W) 243.  
 Mills Mfg. Co., Grapenville, S. C. (C) 265.  
 Mills, W. S., Bridgeport, Conn. (K) 73.

- Millville Mfg. Co., Millville, N. J. (C, BI & D) 152.  
 Milne, C. J. & Sons, Philadelphia, Pa. (W) 222.  
 Milstead Mfg. Co., Convers, Ga. (C) 88.  
 Milwaukee Worsted Cloth Co., Milwaukee, Wis. (W) 251.  
 Milwaukee Worsted Mills, Milwaukee, Wis. (W) 251.  
 Minerjohn, Peter, Philadelphia, Pa. (W) 222.  
 Miner, Chas., Hosiery Co., Brattleboro, Vt. (K) 275.  
 Minneapolis Embroidery Works, Minneapolis, Minn. (S) 132.  
 Minneapolis Knitting Works, Minneapolis, Minn. (K) 139.  
 Minneola Mfg. Co., Gibsonville, N. C. (C) 189.  
 Minnesota Fibre Co., Heron Lake, Minn. (F1) 139.  
 Minster Woolen Mfg. Co., Minster, O. (W) 200.  
 Minto, Jas. D., Manton, R. I. (D) 254.  
 Miriam Textile Mfg. Co., Greenwood, S. C. (C) 265.  
 Mishawaka Woolen Mfg. Co., Mishawaka, Ind. (K) 97.  
 Mishler, John, Smithville, O. (C) 200.  
 Miskell, John, Philadelphia, Pa. (W) 222.  
 Missisquoi Woolen Mill (M. A. Kent) 275.  
 Mississippi Knitting Mills, Meridian, Miss. (K) 141.  
 Mississippi Mills, Wesson, Miss. (C & W) 141.  
 Missouri Cotton Batting & Mfg. Co., St. Louis, Mo. (C) 112.  
 Missouri Mills (W. S. Davis) 211.  
 Mitchell Bros., Amsterdam, N. Y. (W) 161.  
 Mitchell & Townson (Armure Tapestry Mill) 203.  
 Mobile Cotton Mills, Mobile, Ala. (C) 69.  
 Model Carpet Mills (Thomas Boggs & Sons) 205.  
 Model Spinning Co., Woonsocket, R. I. (W) 261.  
 Model Woolen Mill, Indianapolis, Ind. (W) 97.  
 Modena Cotton Mills, Gastonia, N. C. (C) 189.  
 Mohawk Mfg. Co., Oswego, N. Y. (W) 179.  
 Mohawk Mills, Amsterdam, N. Y. (W) 161.  
 Mohawk River Mills, Cohoes, N. Y. (K) 167.  
 Mohawk Valley Cap Factory, Utica, N. Y. (K) 182.  
 Mohawk Valley Knitting Mills, The, Mohawk, N. Y. (K) 172.  
 Mohawk Valley Silk Fabric Co., Canajoharie, N. Y. (S) 166.  
 Mohegan Mills (Wanskuck Co.) 254.  
 Mohr, I. G. & Bros., Reading, Pa. (W) 245.  
 Mohr, Pierce, Adamstown, Pa. (K) 231.  
 Mohrville Knitting Mills, Mohrville, Pa. (K) 241.  
 Moll, August, Mfg. Co., Brooklyn, N. Y. (S) 165.  
 Mollhohn Mfg. Co., Newbury, S. C. (C) 266.  
 Molt Bros., Millbury, Mass. (D) 125.  
 Monardock Mills, Claremont, N. H. (C) 113.  
 Monaghan Mills, Greenville, S. C. (C) 265.  
 Monarch Cotton Mills, Union, S. C. (C) 268.  
 Monarch Knitting Co., Sidney, N. Y. (K) 181.  
 Monarch Silk Co., York, Pa. (S) 250.  
 Monbo Mfg. Co., Monbo, N. C. (C) 192.  
 Monitor Carpet Mill (Dorman Bros.) 213.  
 Monohansett Mfg. Co., Putnam, Conn. (C) 79.  
 Monongahela Textile Co., The, Morgantown, W. Va. (W) 279.  
 Monroe Cotton Mills, Monroe, Ga. (C) 90.  
 Monroe Cotton Mills, Monroe, N. C. (C) 192.  
 Montgomery Carpet Mills (John Hamilton) 217.  
 Montgomery Co., The J. R., Windsor Locks, (C) 83.  
 Montgomery Cotton Mills, Montgomery, Ala. (C) 69.  
 Montgomery Mills (Van Brocklin & Stover Co.) 162.  
 Montgomery Mills, No. Wales, Pa. (C) 213.  
 Monticello Woolen Mills, Monticello, Wis. (W) 282.  
 Montville Woolen Co., Montville, Conn. (W) 76.  
 Monument Mills, Housatonic, Mass. (C) 121.  
 Moody, A., Newfield, N. Y. (W) 173.  
 Moon, Benj., Washington, R. I. (C) 260.  
 Moore, Alfred F., Philadelphia, Pa. (C) 222.  
 Moore, C. & Co., Philadelphia, Pa. (C & F1) 222.  
 Moore Cotton Mills, Lileadown, N. C. (C) 191.  
 Moore, George C., No. Chelmsford and Westford, Mass. (W) 128, 133.  
 Moore, H. W. (Alma Woolen Mill) 135.  
 Moore, I. E. & Co., Philadelphia, Pa. (F) 222.  
 Moore, Sam'l & Sons, Philadelphia, Pa. (D) 222.  
 Moore, Wm., Knitting Co., Cohoes, N. Y. (K) 167.  
 Moore & Bro., Philadelphia, Pa. (W) 222.  
 Moore & Co. (American Flax Fibre Co.) 139.  
 Moore & Tierney, Cohoes, N. Y. (K) 167.  
 Mooresville Cotton Mills, Mooresville, N. C. (C) 192.  
 Moorhead Cotton Mills, Moorhead, Miss. (C) 141.  
 Moosehead Silk Co., Harrison, N. Y. (S, C & L) 169.  
 Moosup Mills, Moosup, Conn. (W) 77.  
 Morel, Emil, Jersey City, N. J. (D) 151.  
 Morgan, H. F., Philadelphia, Pa. (W) 222.  
 Morgan, J. & P. (Albion Knt Goods Co.) 182.  
 Morgan, Thomas, Oneida, N. Y. (K) 178.  
 Morgan, Wm. P., Wilkesbarre, Pa. (K) 250.  
 Morin, J. P. & Co., Leonia, N. H. (K) 145.  
 Moritz, Carl J., Philadelphia, Pa. (S) 222.  
 Morrill Knitting Co., Woonsocket, R. I. (K) 261.  
 Morris, A. V. & Sons, Amsterdam and Ft. Johnson, N. Y. (K) 161, 169.  
 Morris, E. H., Philadelphia, Pa. (W) 222.  
 Morris, G. J., Philadelphia, Pa. (W) 222.  
 Morris & Co., Yardville, N. J. (C) 160.  
 Morris & Ott, Philadelphia, Pa. (W) 222.  
 Morrisania Silk Mills, New York, N. Y. (S) 176.  
 Morrison, J. G., Mariposa, N. C. (C) 192.  
 Morrison, O. & E. G., Tilton, N. H. (W) 147.  
 Morrison Woolen Co., Dexter, Me. (W) 103.  
 Morrow's, G., Sons, Midland Park, N. J. (W) 152.  
 Morse & Kaley Mfg. Co., Milford, N. H. (C) 146.  
 Morse Mills, Putnam, Conn. (C) 79.  
 Morton, Gavin, & Co. (Aylesville Woolen Mills) 181.  
 Moseley & Co., Highlandville, Mass. (K) 120.  
 Moseley, Wm., Needham, Mass. (K) 125.  
 Moss Rose Mfg. Co., Philadelphia, Pa. (C & S) 222.  
 Mossop, Isaac & Co., Wiconisco, Pa. (K) 250.  
 Mott, J. W., Monroese, Pa. (W) 241.  
 Mottram, Thos., Philadelphia, Pa. (K) 222.  
 Moultrie Cotton Mills, Moultrie, Ga. (C) 90.  
 Mountain City Woolen Mills, McInnville, Tenn. (W) 270.  
 Mountain Island Mills, Mountain Island, N. C. (C) 193.  
 Mousam River Mill, Springvale, Me. (W) 107.  
 Mt. Bartie Mfg. Co., Camden, Me. (W) 102.  
 Mt. Bunyan Mills (Grosvenor Woolen Co.) 129.  
 Mt. Holly Cotton Mills, Mt. Holly, N. C. (C) 152.  
 Mt. Holly Hosiery Co., Mount Holly Springs, Pa. (K) 241.  
 Mt. Hope Finishing Co., No. Dighton, Mass. (F) 128.  
 Mt. Pleasant Mfg. Co., Kimesville, N. C. (C) 191.  
 Mt. Vernon Co., Baltimore, Md. (C) 108.  
 Mt. Vernon-Woodbury Cotton Duck Co., Baltimore and Franklinville, Md. (C) 108.  
 Mt. Vernon Worsted Mills, Philadelphia, Pa. (W) 222.  
 Mowry, H. E. (Oak Valley Woolen Mill) 259.  
 Moyer, J. J. J., Womelsdorf, Pa. (K) 250.  
 Moyer, N. H., Boyertown, Pa. (K) 230.  
 Moyer, R. F. & Co., Maucungie, Pa. (K) 240.  
 Moyer & Heister (The Franklin Knitting Mills) 243.  
 Muhlhauser, F. H., Co., Cleveland, O. (W) 198.  
 Mullen, T. F. & Co., Stafford Springs, Conn. (W) 80.  
 Muller, Julius, Brooklyn, N. Y. (K) 165.  
 Muller, Mrs. J., New York, N. Y. (S) 176.  
 Mullholland, Thomas, Philadelphia, Pa. (C & W) 222.  
 Mullineaux, Clegg & Co., Philadelphia, Pa. (W) 222.  
 Mumford River Tape Co., Uxbridge, Mass. (C) 122.  
 Muncie Underwear Co., Muncie, Ind. (K) 97.

- Muncy Woolen Mills Co., Muncy, Pa. (W) 242.  
 Munson, E. G. (Massasoit Knitting Mills) 183.  
 Murchison Cotton Mills, Manchester, N. C. (C) 192.  
 Murdock, Geo. T. & Sons, New Boston, Conn. (W) 77.  
 Murphy Bros., Paterson, N. J. (S) 157.  
 Murphy, John H., Mfg. Co., Cohoes, N. Y. (K) 167.  
 Murphy, Mathew & Son, Philadelphia, Pa. (C) 222.  
 Murphy & Bro., Philadelphia, Pa. (C & W) 222.  
 Murr, W. A., Curwensville, Pa. (C, W & L) 236.  
 Murray, Nicholson, Paterson, N. J. (S) 157.  
 Muscooge Mfg. Co., Columbus, Ga. (C) 88.  
 Musgrove, Chas. M., Pittsfield, Mass. (K) 129.  
 Musgrove Knitting Co., Pittsfield, Mass. (K) 129.  
 Muskegon Knitting Mills (Louis P. Haight) 138.  
 Muskingum Valley Woolen Mfg. Co., Dresden, O. (W) 199.  
 Musser, Jos. & Sons, Lewisburg, Pa. (K) 240.  
 Myer, Richard & Walter Beatty (Saxon Dye Works) 225.  
 Myhnepo Ribbon Mills, College Point, N. Y. (S) 168.  
 Mystic Mfg. Co., Mystic, Conn. (W) 77.  
 Mystic Print & Dye Works, Medford, Mass. (Pr, D & B) 124.  
 Mystic Twine Co., Mystic, Conn. (C) 77.  
 Naef Bros. Co., Paterson, N. J. (S) 157.  
 Namquit Mill (Richmond Mfg. Co.) 251.  
 Nanticoke Knitting Mill (Paul Barrall) 242.  
 Nantucket Mills, Spray, N. C. (C) 195.  
 Naomi Falls Mfg. Co., Randleman, N. C. (C) 194.  
 Napa Woolen Mill, Napa, Cal. (W) 71.  
 Napoleon Woolen Mills, Napoleon, O. (W) 200.  
 Narragansett Knitting Co., Pawtucket, R. I. (K) 256.  
 Narragansett Mills, Fall River, Mass. (C) 117.  
 Narrow Fabric Co., Reading, Pa. (C) 245.  
 Narwood Bros., Brooklyn, N. Y. (D, B1 & F) 165.  
 Nashawannuck Mfg. Co., Easthampton, Mass. (C) 115.  
 Nashua Mfg. Co., Nashua, N. H. (C, Pr & B) 146.  
 Nashua Woolen Mills, Nashua, Iowa (W) 99.  
 Nashville Hosiery Mills, Nashville, Tenn. (K) 270.  
 Nashville Woolen Mill Co., Nashville, Tenn. (W) 270.  
 Nasonville Woolen Co., Nasonville, R. I. (W) 254.  
 Nassau Mills, Brooklyn, N. Y. (W) 165.  
 Natchez Cotton Mills Co., Natchez, Miss. (C) 141.  
 Natick Mills, Natick, R. I. (C) 255.  
 National Braid Co., Brooklyn, N. Y. (S) 165.  
 National Elastic Webbing Co., Providence, R. I. (S & C) 258.  
 National Flax Fibre Co., Millis, Mass. (F) 125.  
 National Knitting Co., Milwaukee, Wis. (K) 281.  
 National Knitting Mills, New York, N. Y. (K) 176.  
 National Knitting Works, Philadelphia, Pa. (K) 222.  
 National Pile Fabric Co., Woonsocket, R. I. (C) 261.  
 National Ribbon Co., Paterson, N. J. (S) 157.  
 National Silk Mills, Baltimore, Md. (S) 108.  
 National Soldiers' Home, Dayton, Ohio (K) 199.  
 National Spinning Co., Philadelphia, Pa. (C) 222.  
 National Underwear Co., Spring City, Pa. (K) 248.  
 National & Providence Worsted Mills, Providence, R. I. (W) 258.  
 Naunkeag Steam Cotton Co., Salem, Mass. (C) 120.  
 Naushon Co., Woonsocket, R. I. (C) 261.  
 Nazareth Mfg. Co., Nazareth, Pa. (K) 242.  
 Neale & Goode, Paterson, N. J. (D) 157.  
 Nebraska Binder Twine Co., Fremont, Neb. (F) 142.  
 Nelderauer, Henry, Hamilton, O. (K) 199.  
 Neiman's, M., Sons, New York, N. Y. (K) 176.  
 Nelson Bros., Duluth and Minneapolis, Minn. (K) 139, 140.  
 Nelson, Christ. (Nelson Bros.) 140.  
 Nelson, Hugh, Philadelphia, Pa. (W) 223.  
 Nelson Knitting Co., Rockford, Ill. (K) 96.  
 Nelson Knitting Co., Middleville, N. Y. (K) 172.  
 Nelson, W. B., Lexington, Ky. (F) 100.  
 Nelson & Glenallen Mills (N. D. White & Sons) 134.  
 Nemasket Mills, Taunton, Mass. (C) 131.  
 Neptune Mills (E. Emory Johnson) 76.  
 Neuburger, Meindendorf & Phillips Silk Co., Paterson, N. J. (S) 157.  
 Neuburger Silk Co., Paterson, N. J. (S) 157.  
 Neudorfer & Hochbaum, New York, N. Y. (S) 176.  
 Neuse River Mills, Raleigh, N. C. (C) 193.  
 Neversink Dye Works (Knoll & Althouse) 245.  
 New Albany Hosiery Mills, New Albany, Ind. (K) 98.  
 New Albany Woolen Mills Co., New Albany, Ind. (W) 98.  
 New Bedford Cordage Co., New Bedford, Mass. (J) 126.  
 New Bedford Spinning Co., New Bedford, Mass. (C) 126.  
 New Bedford Textile School, New Bedford, Mass. 126.  
 New Britain Knitting Co., New Britain, Conn. (K) 77.  
 New Century Cotton Mills, Douglasville, Ga. (C) 82.  
 New Century Cotton Mills, Dallas, Texas (C) 271.  
 New Cumberland Knitting Co., New Cumberland, Pa. (K) 242.  
 New England Bunting Co., Lowell, Mass. (W) 123.  
 New England Co., Rockville, Conn. (W) 79.  
 New England Cotton Yarn Co., New Bedford, Mass. (C) 126.  
 New England Dyeing Mill, Worcester, Mass. (W) (See too late classification list.)  
 New England Dyeing & Finishing Co., Boston, Mass. (D & F) 112.  
 New England Edging Co., Woonsocket, R. I. (K) 261.  
 New England Electrical Works, Lisbon, N. H. (C) 146.  
 New England Knitting Co., Winsted, Conn. (K) 82.  
 New England Thread Co., Pawtucket, R. I. (C, D & B) 256.  
 New England Warp Co., New Haven, Conn. (C & D) 77.  
 New Hampshire Hair Works (John Slack) (C) 146.  
 New Hampshire Spinning Mills, Penacook, N. H. (C) 147.  
 New Hartford Cotton Mfg. Co., New Hartford, N. Y. (C) 173.  
 New Haven Web Co., New Haven, Conn. (C) 77.  
 New Holland Silk Mill, New Holland, Pa. (S) 242.  
 New Iberia Cotton Mill Co., Ltd., New Iberia, La. (K) 101.  
 N. J. Hat Works, Jersey City, N. J. (W) 151.  
 New Jersey Silk Mfg. Assn., Paterson, N. J. (S) 157.  
 New Jersey Wick Co., Newark, N. J. (C) 152.  
 New London Steam Woolen Mill Co., New London, Conn. (W) 77.  
 New London Wash Silk Co., New London, Conn. (S) 78.  
 New York Braid Co., New York, N. Y. (S) 176.  
 New York Carpet Lining Co., New York, N. Y. (C) 174.  
 New York Corduroy Mill, New York, N. Y. (C) 176.  
 New York Cotton Batting Co., Lockport, N. Y. (C) 171.  
 New York Insulated Wire Co., Wallingford, Conn. (C) 81.  
 New York Knitting Mills, New York, N. Y. (K) 176.  
 New York Mills, The, New York Mills, N. Y. (C, B1 & D) 178.  
 New York Net & Twine Co., Moodus, Conn. (C) 76.  
 New York Silk Conditioning Co., New York, N. Y. (D) 174.

- New York Tapestry Mills, Philadelphia, Pa. (W) 223.
- New York Textile Co., New York, N. Y. (C) 176.
- New York T. & C. Co., New York, N. Y. (S) 176.
- New York Watering Co., New York, N. Y. (D & F) 174.
- New York Woven Label Mfg. Co., New York, N. Y. (S) 176.
- New York & Brooklyn Silk Mfg. Co., Paterson, N. J. (S) 157.
- Newberry Cotton Mills, Newberry, S. C. (C) 266.
- Newberry Knitting Mill, The, Newberry, S. C. (K) 266.
- Newbold & Co., Philadelphia, Pa. (W) 223.
- Newburgh Bleachery, Newburgh, N. Y. (Bl & F) 173.
- Newburgh Steam Mills, Newburgh, N. Y. (C) 173.
- Newburgh Woolen Mills, Newburgh, N. Y. (W) 173.
- Newfield Smyrna Rug Co., Newfield, N. J. (W) 152.
- Newichawanick Co., So. Berwick, Me. (W) 107.
- Newington Knitting Works, Newington, Conn. (K) 77.
- Newland, Denison & Co., Stillwater, N. Y. (K) 181.
- Newland, R. & H., Stillwater, N. Y. (K) 181.
- Newland & Neilson (Knickerbocker Hosiery Mills) 172.
- Newmarket Mfg. Co., Newmarket, N. H. (C & S) 146.
- Newnan Cotton Mills, Newnan, Ga. (C) 90.
- Newport Hosiery & Mitten Mill (D. W. Smith) 173.
- Newport Knitting Co., Newport, N. Y. (K) 173.
- Newport Woolen Co., Newport, Me. (W) 105.
- Newsome, D. (Byram Mfg. Co.) 235.
- Newsome, Herbert, Philadelphia, Pa. (S) 223.
- Newton Cotton Mills, The, Newton, N. C. (C) 192.
- Newton, Herbert B., Philadelphia, Pa. (C) 223.
- Newton Hosiery Mills, Newton, N. C. (K) 193.
- Newton, J. & H. Bennett (De Lyte Tapestry Mills) 211.
- Newton Mills, Newton Upper Falls, Mass. (S) 127.
- Newton & Co., Homer, N. Y. (W) 170.
- Newville Knitting Co., Newville, Pa. (K) 242.
- Niagara Cotton Batting Co., Lockport (C) 171.
- Niagara Falls Hair Cloth Works, Niagara Falls, N. Y. (C) 178.
- Niagara Textile Co., Lockport, N. Y. (C & F) 171.
- Niantic Mfg. Co., Mill No. 1, East Lyme, Conn. (W) 75.
- Nietown Hosiery Mills (Geo. Schmidt & Bro.) 226.
- Nietown Mills (F. W. Walter & Co.) 229.
- Nichols & Langworthy Machine Co., Hope Valley, R. I. (C) 254.
- Nicol, W. & Co., Vineland, N. J. (S) 159.
- Niedner, Chas., Malden, Mass. (C) 124.
- Nightingale, Joseph, Paterson, N. J. (W & S) 157.
- Nightingale Mills, Putnam, Conn. (C) 79.
- Nims Mfg. Co., Mt. Holly, N. C. (C) 193.
- Nippenose Woolen Mills (Leinbach Woolen Co.) 221.
- Nitre Hall Mill (John Burns) 233.
- Nixon, W. K., Philadelphia, Pa. (K) 223.
- Nockege Mills, Fitchburg, Mass. (C) 118.
- Nokomis Cotton Mills, Lexington, N. C. (C) 191.
- Nolan, John, Philadelphia, Pa. (D) 223.
- Nolan, Joseph, Brooklyn, N. Y. (K) 165.
- Nolde & Horst Co., Reading, Pa. (K) 245.
- Nonantum Mills, Newton, Mass. (W) 126. Also see too late classification.
- Nonotuck Silk Co., Florence, Mass. (S) 119.
- Noor, R. E., Statesville, N. C. (C) 195.
- Noon, E. & Son, Philadelphia, Pa. (K) 223.
- Noone's Sons Co., The Joseph, Peterboro, N. H. (W) 147.
- Norfolk Knitting Mills, Norfolk, Va. (K) 277.
- Norfolk Mfg. & Spinning Co., Norfolk, Va. (W) 277.
- Norfolk Mill, Dedham, Mass. (W) 115.
- Norfolk Mills (Cotton Oil & Fibre Co.) 277.
- Norfolk Silk Co., Norfolk, Va. (S) 277.
- Norfolk Woolen Co., Franklin, Mass., and (Ray Fabric Mills) (W) 119.
- Norfolk Woolen Mills, Norfolk, N. Y. (W) 178.
- Norfolk & New Brunswick Hosiery Co., Norfolk, Conn., and New Brunswick, N. J. (W) 78, 152.
- Norman & Evans, Lockport, N. Y. (W) 171.
- Norris Carpet Mills (Dan'l Currie) 211.
- Norris Cotton Mills Co., Catachee, S. C. (C) 262.
- Norris, John, Philadelphia, Pa. (W & C) 223.
- Norristown Hosiery Co., Norristown, Pa. (K) 242.
- Norristown Woolen Co., Norristown, Pa. (W) 242.
- No. Adams Mfg. Co., North Adams, Mass. (W) 127.
- No. Andover Silk Wiping Cloth Mfg. Co., No. Andover, Mass. (S) 127.
- No. Berwick Co., No. Berwick, Me. (W) 105.
- North Brook Woolen Mills (T. P. Jenks) 193.
- North Gray Woolen Mill, No. Gray, Me. (W) 105.
- North, Joseph W. & Sons, Elizabeth, N. J. (K) 149.
- N. Pownal Mfg. Co., North Pownal, Vt. (C) 275.
- No. Scituate Cotton Mills, No. Scituate, R. I. (C) 255.
- North Star Woolen Mill Co., Minneapolis, Minn. (W) 140.
- No. Windham Mills, No. Windham, Conn. (C) 78.
- North & Doyle (Anchor Hosiery Mills) 166.
- Northboro Woolen Mills, The, Chapinville, Mass. (W) 112.
- Northern Ohio Blanket Mills (The Beckman Co.) 182.
- Northfield Knitting Co., Northfield, Minn. (K) 140.
- Northrop, D. W., Utica, N. Y. (K) 182.
- Northville Knitting Mill, Northville, N. Y. (K) 178.
- Northwestern Grass Twine Co., Oshkosh, Wis. (J) 282.
- Northwestern Knitting Co., Minneapolis, Minn. (K) 140.
- Northwestern Tow Co., Elma, Ia., and Hammond, Wis. (F) 99, 281.
- Norton Mills Co., Norton, Mass. (W) 128.
- Norwalk Mills Co., Winnipauk, Conn. (W) 83.
- Norway Plains Co., Rochester, N. H. (W) 147.
- Norwich Silk Mfg. Co., Norwich, N. Y. (S) 178.
- Norwood Mfg. Co., Norwood, N. C. (C) 193.
- Nottingham Mills, Providence, R. I. (C) 258.
- Novak, Joseph, West Hoboken, N. J. (W) 160.
- Novelty Art Square & Carpet Co., Philadelphia, Pa. (W) 223.
- Novelty Braid Mill (Grossenbach & Van Nostitz) 174.
- Novelty Cordage Works (Edwin J. Ellis) 182.
- Novelty Knitting Co., Detroit, Mich. (K) 137.
- Novelty Knitting Co., Albany, N. Y. (K) 161.
- Novelty Knitting Mill (John Axford) 203.
- Novelty Knitting Mills (Feld & Co.) 213.
- Novelty Knitting Underwear Co., Waterford, N. Y. (K) 182.
- Novelty Silk Printing Co., Paterson, N. J. (Pr) 157.
- Novelty Suspend-er Works (Josiah Harriman) 123.
- Nufer, E., Jersey City, N. J. (S) 151.
- Nusbaum, D. (Brooklyn Knitting Co.) 164.
- Nutley Mills (J. W. Pearson Co.) 153.
- Nuttall, L., Philadelphia, Pa. (Pr) 223.
- Nutty, J. C. (Paperville Woolen Mills) 271.
- Nyaek Knitting Co., Nyaek, N. Y. (K) 178.
- Nye & Wait Carpet Co., Auburn, N. Y. (W) 163.
- Oak Hall Woolen Mill, Oak Hall Station, Pa. (W) 212.
- Oak Hill Mill, Wickford, R. I. (W) 260.
- Oak Knitting Co., Syracuse, N. Y. (K) 181.
- Oak Valley Woolen Mill, Tarklin, R. I. (W) 259.
- Oakdale Cordage Company, Turnerville, Conn. (C & S) 81.
- Oakdale Cotton Mills, Jamestown, N. C. (C) 190.
- Oakdale Mills, Oakdale, Conn. (C) 78.
- Oakes, Thomas & Co., Bloomfield, N. J. (W) 148.
- Oakland Mfg. Co., Baltimore, Md. (W) 108.

- Oakland Mills, Taunton, Mass. (C) 131.  
 Oakland Woolen Co., Oakland, Me. (W) 105.  
 Oakland Worsted Co., Oakland, R. I. (W) 255.  
 O'Connell & Co. (Marion Hosiery Mills) 221.  
 O'Connor Bros., Paterson, N. J. (S) 157.  
 Octoraro Linen Finishing Company, Philadelphia, Pa. (F) (See too late classification list.)  
 Octoraro Mills Co., Clio, S. C. (C) 263.  
 Odell, J. M., Mfg. Co., Bynum, N. C. (C) 185.  
 Odell Mfg. Co., Concord, N. C. (C) 187.  
 Odenwelder & Co., Bath, Pa. (K) 233.  
 O'Donnell, Wm. J., Phoenixville, Pa. (K) 243.  
 Oehrle Bros. & Co., Philadelphia, Pa. (S) 223.  
 Offerman, Mrs. Wm., Red Bud, Ill. (K) 96.  
 Ogburn, J. S. & Co., Lindale, Texas (K) 272.  
 Ogden, Chas. H., Springvale, Me. (W) 107.  
 Ogden Knitting Factory, Ogden, Utah (K) 273.  
 (See also Western Knitting Co. Too late classification list.)  
 Ogden Woolen Mills, Ogden, Utah (W) 273.  
 Ogden's, James, Sons, Rosenwick, Pa. (W) 246.  
 Ogdensburg Woolen Mill (F. S. McGuire Co., Ltd.) 178.  
 Ohio Cordage Mill, Xenia, O. (F) 201.  
 Ohio Falls Dye & Finishing Works, Louisville, Ky. (D & F) 101.  
 Ohio Falls Warp Mill, New Albany, Ind. (C) 98.  
 Ohio Knitting Mills Co., Toledo, O. (K) 200.  
 Olde & Broeker, New York, N. Y. (S) 176.  
 Okonite Co., Ltd., Passaic, N. J. (C) 153.  
 Old Town Woolen Co., Old Town, Me. (W) 105.  
 Oldham Mills, Philadelphia, Pa. (W & S) 223.  
 Olmsted & Tuttle Co., Chicopee, Mass. (C) 114.  
 Olney, Geo. W., Woolen Co., Cherry Valley, Mass. (W) 114.  
 Olson Rug Co., Chicago, Ill. (W) 93.  
 Olympia Cotton Mills, Columbia, S. C. (C) 263.  
 Olympia Mills (Rudolph Blakenburg & Co.) 205.  
 Olympian Knit Goods Co., New Hartford, N. Y. (K) 172.  
 Olzendam, A. P., Hosiery Co., Manchester, N. H. (K) 146.  
 Omaha National Knitting Factory, Omaha, Neb. (K) 142.  
 Onalaska Mfg. Co., The, Onalaska, Wis. (W) 282.  
 Onandaga Knitting Mills (West Bros.) 181.  
 Oneida Community, Ltd., Kenwood, N. Y. (S) 171.  
 Oneida Cotton Mills, Graham, N. C. (C) 189.  
 Oneida Hosiery Co., Oneida, N. Y. (K) 178.  
 Oneida Knitting Co., Depere, Wis. (K) 281.  
 Oneida Knitting Mills, Utica, N. Y. (K) 182.  
 O'Neil Bros., Philadelphia, Pa. (W) 223.  
 O'Neil, John, Philadelphia, Pa. (W) 223.  
 O'Neil, Wm., Philadelphia, Pa. (C, W & L) 223.  
 O'Neil & Conney, Philadelphia, Pa. (C) 223.  
 Oneko Mills, New Bedford, Mass. (W) 126.  
 Ontario Mill (Merz & Bruhm) 222.  
 Ontario Spinning Co., Philadelphia, Pa. (C) 223.  
 Opelika Cotton Mills, Opelika, Ala. (C) 69.  
 Oppr, H. L. & Bros., New York, N. Y. (S) 176.  
 Orange Knitting Co., Farley and Shelburne Falls, Mass. (K) 118, 130.  
 Orange Mill (Geo. H. Cornelson) 266.  
 Orangeburg Knitting Mill, Orangeburg, S. C. (K) 266.  
 Orangeburg Mfg. Co., Orangeburg, S. C. (C) 266.  
 Oregon City Mfg. Co., Oregon City, Ore. (W) 201.  
 Orianna Bleach Works (Davidson & Brooke) 211.  
 Orient Mfg. Co., Charlotte, N. C. (C) 187.  
 Oriental Mfg. Co., Providence, R. I. (C) 258.  
 Oriental Mills (Geo. Brooks & Son) 207.  
 Oriental Mills (H. H. Wood & Co.) 145.  
 Oriental Print Works, Apponaug, R. I. (Pr, B1 & D) 251.  
 Oriental Rug Works, Skowhegan, Me., and Barre, Mass. (J) 107, 111.  
 Oriental Silk Printing Co., Paterson, N. J. (Pr, D & F) 157.  
 Oriental Silk Thread Co., Pittsfield, Mass. (S) 129.  
 Oriental Textile Mills, Houston Heights, Texas (W) 272.  
 Oriental Weaving Co., New York, N. Y. (S) 176.  
 Orinoko Mills, Philadelphia, Pa. (S) 223.  
 Orion Knitting Mills, Kingston, N. C. (K) 191.  
 Orion Silk Mfg. Co., Paterson, N. J. (S) 157.  
 Orkney Mill (David S. Johnston) 167.  
 Orleans Mills, Trenton, N. J. (W) 159.  
 Ormsby Textile Co., Waterford, N. Y. (K) 182.  
 Orndorff, F. C., Worcester, Mass. (C) 134.  
 Orr Bros., Pawtucket, R. I. (D & F) 256.  
 Orr, Chas. F., Mansfield, Mass. (C) 124. (Also see Too Late Classification List.)  
 Orr Cotton Mills, Anderson, S. C. (C) 262.  
 Orr Felt & Blanket Co., Piqua, O. (W) 200.  
 Orr, James, Attleboro, Mass. (D & F) 111.  
 Orrell, William (Glendale Woolen Mill) 254.  
 Orswell Mills, Fitchburg, Mass. (C) 119.  
 Orwigsburg Knitting Mills, Orwigsburg, Pa. (K) 243.  
 Osborne Mills, Fall River, Mass. (C) 117.  
 Osborne, M. A., Brooklyn, N. Y. (K) 165.  
 Osborne, Owen, Philadelphia, Pa. (K) 223.  
 Osborne, Wm., Philadelphia, Pa. (K) 223.  
 Osgood Mills, No. Andover, Mass. (W) 127.  
 O'Shea Bros. (Dennis O'Shea) 145.  
 O'Shea, Dennis, Laconia, N. H. (K) 145.  
 Osler & Elder, Bryan Mill, Pa. (W) 234.  
 Oslo Woolen Mill, Oslo, Wis. (W) 282.  
 Ossawan Mills Co., Norwich, Conn. (C) 78.  
 Ossipee Cotton Mills (Jas. N. Williamson & Sons) 188.  
 Ostermoor & Co., New York, N. Y. (W) 176.  
 Oswego Knitting Co., Oswego, N. Y. (K) 179.  
 Otis Co., Ware, Mass. (C & K) 133.  
 Otobando Woolen Mill, Norwich, Conn. (W) 78.  
 Ottaquechee Woolen Co., No. Hartland, Vt. (W) 275.  
 Otter Knitting Co., Utica, N. Y. (K) (See Too Late Classification List.)  
 Otter River Mills, Otter River, Mass. (W) 128.  
 Otto Woolen Mills (Charles B. Pierce) 179.  
 Ottoman Mill (M. E. Brooke) 207.  
 Ouachita Cotton Mills, Arkadelphia, Ark. (C) 70.  
 Ouachita Cotton Mills, Monroe, La. (C) 101.  
 O. U. O. Factory Co., Orderville, Utah (W) 273.  
 Ounegan Woolen Co., Old Town, Me. (W) 105.  
 Overbrook Mills (Glenside Woolen Mills) 181.  
 Overland Cotton Mill Co., Denver, Col. (C) 72.  
 Overman & Schrader Cordage Co., Covington, Ky. (J) 100.  
 Owaneco Silk Co., Norwich and Preston, Conn. (S) 79.  
 Oxford Carpet Mill (Wm. B. Keefer) 219.  
 Oxford Cotton Mill Co., Oxford, N. C. (C) 193.  
 Oxford Hosiery Mill (Wm. Sullivan & Co.) 227.  
 Oxford Knitting Mill (Justus Koch) 219.  
 Oxford Knitting Mills, Barnesville, Ga. (K) 86.  
 Oxford Woolen Mills (A. Howarth & Sons) 128.  
 Ozark Cotton Mills, Gastonia, N. C. (C) 189.  
 Paas, Carl, Co., Newark, N. J. (C & S) 152.  
 Pacific Fringe Factory (Auerbach & Thompson) 71.  
 Pacific Hosiery Mills (Clarke & Holsapple Mfg. Co.) 167.  
 Pacific Mills, Lawrence, Mass. (C, W & Pr) 122.  
 Packer's Mill (E. A. Cutler) 78.  
 Paeolet Mfg. Co., Gainesville, Ga., and Paeolet, S. C. (C) 89, 267.  
 Page Mfg. Co., Cohoes, N. Y. (C) 167.  
 Palace Ribbon Mfg. Co., Allentown, Pa. (S) 231.  
 Palisade Silk Co., West New York, N. J. (S) See Too Late Classification List.  
 Palmer, Baldwin (Evergreen Knitting Works) 164.  
 Palmer Bros., Bozrah, New London, Conn. (C) 72, 78.  
 Palmer Carpet Mfg. Co., Palmer, Mass. (W) 129.  
 Palmer, L. E. (Arrowanna Mills), Middletown and Turnersville, Conn. (C) 76, 81.  
 Palmer, J. S. & Son, Philadelphia, Pa. (K) 223.  
 Palmer Mill of the Otis Co., Three Rivers and Ware, Mass. (C) 132, 133.  
 Palmer, R. C. (Oak Hall Woolen Mill) 243.  
 Palmer, R. T., Co., New London, Conn. (C) 78.  
 Palmetto Cotton Mills, Palmetto, Ga. (C) 90.  
 Palmetto Cotton Mills, Columbia, S. C. (C) 263.  
 Palmetto Knitting Mills, Blackville, S. C. (K) 262.  
 Palmyra Hosiery Mill, Palmyra, Pa. (K) 243.

- Paoli Bleach Works, Philadelphia, Pa. (B) 223.  
 Paoli Milling Co., Paoli, Ind. (W) 93.  
 Paperville Woolen Mills, Paperville, Tenn. (W) 271.  
 Paragon Knitting Co., The, Mohawk, N. Y. (K) 172.  
 Paragon Silk Co., Paterson, N. J., and Oneonta, N. Y. (S) 157, 178.  
 Paragon Woolen Mills, West Mitchell, Iowa (W) 99.  
 Paramount Knitting Co., Chicago, Ill. (K) 93.  
 Paramount Worsted Mills, The, Providence, R. I. (W) 258.  
 Parham, W. T. & Sons, Knoxville, Tenn. (W) 270.  
 Paris Knitting Mill (John H. Murphy Mfg. Co.) 167.  
 Paris Textile Co., Paris, Texas (C) 272.  
 Paris Woolen Mill, Paris, Mo. (W) 112.  
 Park, Angus (Airlie Mills) 75.  
 Park Carpet Mills (John Gay's Sons, Inc.) 215.  
 Park Knitting Mills (L. L. Dean & Co.) 161.  
 Park Knitting Works, Hartford, Conn. (K) 75.  
 Park, L. M. & Sons (Park Mills) 90.  
 Park Mills, La Grange, Ga. (C) 90.  
 Park Woolen Mills, Rossville, Ga. (W) 91.  
 Park Worsted Mill (Wm. E. Walsh) 124.  
 Parker Bros. Mfg. Co., Lynn, Mass. (C) 124.  
 Parker, Joseph A., Portsmouth, Va. (K) 278.  
 Parker, J. C. Co., Quechee, Vt. (W) 275.  
 Parker Mills, Fall River, Mass., and Warren, R. I. (C) 118, 260.  
 Parker, Richard H., Reading, Pa. (K) 245.  
 Parker & Stockert (Buckhannon Woolen Mills) 279.  
 Parkhill Mfg. Co., Fitchburg, Mass. (C) 119.  
 Parkinson, Edw., Philadelphia, Pa. (K) 223.  
 Parkinson & Lans (Irent Mills) 92.  
 Parsons Mfg. Co., Cohoes, N. Y. (K) 167.  
 Parsons Silk Throwing Co., Parsons, Pa. (S) 243.  
 Parsons, Wm., Philadelphia, Pa. (C & W) 223.  
 Parsons & Angstadt, Phoenixville, Pa. (K) 243.  
 Parsons & Baker, Phoenixville, Pa. (K) 243.  
 Partridge, E. E. & Co., Athol, Mass. (W) 111.  
 Passa, Adolph, Brooklyn, N. Y. (S) 165.  
 Passaic Mills (A. McLean Co.) 153.  
 Passaic Print Works, Passaic, N. J. (Pr & D) 153.  
 Passaic Woolen Co., Passaic, N. J. (W) 153.  
 Passale Worsted Mills, The, Passaic, N. J. (W) 153.  
 Patapesc Electric & Mfg. Co., Ellicott City, Md. (C) 168.  
 Patchogue Mfg. Co., Patchogue, N. Y. (C) 179.  
 Patent Cloth Splicing & Finishing Co., New York, N. Y. (F) 177.  
 Patent Woolen Co., Cornwall, N. Y. (W) 168.  
 Paterson, James & Co., Lawrence, Mass. (W) 122.  
 Paterson Mfg. Co., China Grove, N. C. (C) 187.  
 Paterson Silk Textile Institute, Paterson, N. J. (S) (See Too Late Classification List)  
 Paterson Silk & Dyeing Assn., Paterson, N. J. (D & F) 157.  
 Paton, Wm., Ltd., No. Grafton, Mass. (C) 128.  
 Patterson Bros. & Co., Paterson, N. J. (D & F) 157.  
 Patterson Mfg. Co., Philadelphia, Pa. (C & J) 223.  
 Patterson Textile Co., Roanoke Rapids, N. C. (S) 194.  
 Pausasset Mills (A. H. & C. B. Alling) 73.  
 Paulding County Cotton Mfg. Co., Dallas, Ga. (C) 88.  
 Pautsch, J. E. (Centerport Knitting Mill) 234.  
 Pavonia Knitting Mills, Jersey City, N. J. (K) 151.  
 Pawtucket Braided Line Co., Pawtucket, R. I. (C & S) 256.  
 Pawtucket Dyeing & Bleaching Co., Pawtucket, R. I. (D & B) 256.  
 Pawtucket Tape Co., Pawtucket, R. I. (C) 257.  
 Paxton, Levi B., Jr. (Keystone Knitting Mills) 245.  
 Pay Down Woolen Mill (T. A. Bray) 142.  
 Payne Cotton Mills, Macon, Ga. (C) 90.  
 Payne, Wm. H., Dayton, O. (F) 199.  
 Payton, Albert J., Philadelphia, Pa. (Pr & F) 222.  
 Peabody Mfg. Co., Newburyport, Mass. (C) 126.  
 Peabody, S. L., Princeton, Me. (W) 106.  
 Peace Dale Mfg. Co., Peace Dale, R. I. (W) 257.  
 Peace, Herbert, No. Vassalboro, Me. (W) 105.  
 Pearce, Atkins & Co. (Franklin Cotton Mill) 198.  
 Pearce, Jno. & Sons, Greenville, Pa. (W) 238.  
 Pearl Cotton Mills, Beverly, Ga. (C) 86.  
 Pearl Cotton Mills, East Durham, N. C. (C) 188.  
 Pearl, I. L. & Co., Johnson, Vt. (W) 275.  
 Pearl Knitting Mills, Cohoes, N. Y. (K) 167.  
 Pearson, J. W., Co., Nutley, N. J. (S) 153.  
 Peberdy, Geo., Philadelphia, Pa. (K) 223.  
 Peck, Frank L., Gloversville, N. Y. (K) 168.  
 Peck Mfg. Co., Pittsfield, Mass. (C & W) 129.  
 Peckham, L<sup>co</sup> W., Thornton, R. I. (W) 260.  
 Peckham Mfg. Co., Washington, R. I. (W) 260.  
 Peddicord, Inskip & Hess, Washington, O. (K) 200.  
 Pee Dee Mfg. Co., Rockingham, N. C. (C) 194.  
 Peel, Robert, Philadelphia, Pa. (K) 223.  
 Peerless Finishing Co., Nyack, N. Y. (D & F) 178.  
 Peerless Knitting Mills, Brooklyn, N. Y. (K) 165.  
 Peerless Knitting Mills Co., Toledo, O. (K) 260.  
 Peerless Plush Mfg. Co., Paterson, N. J. (C, W & S) 157.  
 Peerless Silk Dye Works, Philadelphia, Pa. (B) & D) 222.  
 Peerless Union Underwear Co., Boston, Mass. (K) 112.  
 Pelgram & Meyer, Boonton, Paterson, N. J., and Harrisburg, Pa. (S) 148, 157, 238.  
 Pelham Mfg. Co., Pelham, Ga. (C) 90.  
 Pelham Mills, Pelham, S. C. (C & K) 267.  
 Pell City Mfg. Co., Pell City, Ala. (C) (See Too Late Classification List).  
 Pelzer Mfg. Co., Pelzer, S. C. (C) 267.  
 Pemberton Co., Lawrence, Mass. (C) 122.  
 Pembroke Mills, Suncook, N. H. (C) 147.  
 Pemstein, N. (Worcester Dusting Mill) 135.  
 Pendergast, Daniel, Franklin, Mass. (W) 119.  
 Pendlebury, S. & Son, Philadelphia, Pa. (D & Pr) 223.  
 Pendleton Mfg. Co., Autun, S. C. (C) 262.  
 Pendleton Wool Scouring & Packing Co., Pendleton, Ore. (W) 291.  
 Pendleton Woolen Mills, Pendleton, Ore. (W) 291.  
 Penfield Hosiery Mill, Penfield, Ga. (K) 90.  
 Penn Art Square Mill (Hirsch & Lazareth) 242.  
 Penn Artistic Weaving Co., Philadelphia, Pa. (S) 223.  
 Penn Knitting Co., Philadelphia, Pa. (K) 223.  
 Penn Textile Mfg. Co., Pottsville, Pa. (S, D & B) 244.  
 Penn Worsted Co., Philadelphia, Pa. (W) 223.  
 Penn Worsted Mills (Yewdall & Jones) 230.  
 Pennant Knitting Co., Shepherdstown, W. Va. (K) 279.  
 Pennsylvania Knitting Mills, Reading, Pa. (K) 245.  
 Pennsylvania Net Co., Wellsville, Pa. (C) 249.  
 Pennsylvania Silk Mills, Fleetwood, Pa. (S) 231.  
 Pennsylvania Silk Mills (Scherr Bros.) 225.  
 Pennypack Yarn Finishing Co., Philadelphia, Pa. (F) 224.  
 People's Cotton Factory, Montgomery, Ala. (C) 69.  
 People's Mfg. Co., Winston-Salem, N. C. (K) 197.  
 Peoria Cordage Co., Peoria, Ill. (J) 96.  
 Pepperell Mfg. Co., Biddeford, Me. (C) 102.  
 Pepperton Cotton Mills, Jackson, Ga. (C) 89.  
 Pequea Mills, Philadelphia, Pa. (W) 224.  
 Pequot Mills (John F. Lodge & Sons) 230.  
 Pequot Mills of the Attawaugan Co., Montville, Conn. (C) 76.  
 Perkins, J. T. Co., Brooklyn, N. Y. (W) 165.  
 Perkiomen Knitting Mills, Collegeville, Pa. (K) (See Too Late Classification List).  
 Perrin, H. O. & Co., New York, N. Y. (S) 177.  
 Perry, Fergus, Philadelphia, Pa. (S) 224.  
 Perry Glove & Mitten Co., Perry, Mich. (K) 128.  
 Perry, Josiah, Webster, Mass. (W) 132.

- Perry Knitting Co., The, Perry, N. Y. (K) 179.  
 Perry Knitting Mill (Couch & Moreland) 233.  
 Perry Knitting Mill (Perry Glove & Mitten Co.) 138.  
 Perry Yarn Mills, Webster, Mass. (W) 133.  
 Perryville Woolen Co. (L. D. Marble & Son) 239.  
 Perseverance Knitting Co., Ltd., Phoenixville, Pa. (K) 243.  
 Perseverance Mill (Thos. W. Greaves) 216.  
 Perseverance Mills (John P. Holt) 218.  
 Perseverance Worsted Co., Woonsocket, R. I. (W) 261.  
 Persian Mills (Sam'l B. Bunting) 209.  
 Persian Rug Manufactory, New York, N. Y. (W) 177.  
 Peru Bagging Mfg. Co., Peru, Ind., and Louisville, K. (J) 88, 101.  
 Peter, Estate of Wm. (Columbiaville Woolen Mills) 137.  
 Peters Trimming Co., Chicago, Ill. (S) 95.  
 Petersburg Hosiery Co., Petersburg, Va. (K) 277.  
 Petersburg Silk Mill, Dunmore, Pa. (S) 237.  
 Peterson, Geo. W., agt., Philadelphia, Pa. (F) 224.  
 Peterson, P., Chicago, Ill. (W) 95.  
 Peterson, Peter R. & Co., Fairview, Utah (K) (See Too Late Classification List)  
 Pettigrew, F. W., Est. of, Sioux Falls, S. D. (W) 268.  
 Pettit & Co., Lockport, N. Y. (C) 171.  
 Petzoldt, H. & Sons, Philadelphia, Pa. (W) 224.  
 Petzoldt, L. H., Philadelphia, Pa. (W & C) 224.  
 Pfaffman, Philip, Cherry Valley, Mass. (W) 114.  
 Pfeifer & Co., Chicago, Ill. (D & F) 95.  
 Pfeifer, Anna, Trenton, N. J. (K) 159.  
 Pfingst, Geo. B. (Lee Hosiery Mills) 220.  
 Pfister, J. J., Knitting Co., San Francisco, Cal. (K) 72.  
 Phalanx Silk Mill, Jersey City, N. J. (S) 151.  
 Philadelphia Cordage Works (Edwin H. Filiter Co.) 215.  
 Philadelphia Dye Works, Philadelphia, Pa. (D) 224.  
 Philadelphia Hosiery Finishing Works, Philadelphia, Pa. (F) 224.  
 Philadelphia Knitting Mills Co., Philadelphia, Pa. (K) 224.  
 Philadelphia Tapestry Mills, Philadelphia, Pa. (C & S) 224.  
 Philadelphia Textile School, Philadelphia, Pa. (C, W & D) 224.  
 Philadelphia Thread Co., Philadelphia, Pa. (C) 224.  
 Philadelphia Truss Co., Philadelphia, Pa. (K) 224.  
 Philadelphia Worsted Co., Camden, N. J. (W) 149.  
 Phillips Insulated Wire Co., Pawtucket, R. I. (C) 257.  
 Phillips Woolen Co., The, Phillips, Me. (W) 106.  
 Phillipsburg Hosiery Mills Co., Phillipsburg, N. J. (K) 158.  
 Phillipsburg Silk Mill Co., Easton, Pa. (S) 237.  
 Phoenix Carpet Mill (Moore & Bro.) 222.  
 Phoenix Cotton Mills, Nashville, Tenn. (C) 270.  
 Phoenix Factory, Debruce, Ga. (C) 88.  
 Phoenix Knitting Works, Milwaukee, Wis. (K) 281.  
 Phoenix Mfg. Co., Peterboro, N. H. (C) 147.  
 Phoenix Mills, East Greenwich, R. I. (W) 253.  
 Phoenix Mills Co., Philadelphia, Pa. (W) 224.  
 Phoenix Silk Mfg. Co., Paterson, N. J., and Allentown, Pa. (S) 157, 231.  
 Phoenix Spinning Co., Providence, R. I. (W) 258.  
 Phoenix Trimming Co., Chicago, Ill. (S) 95.  
 Phoenix Woolen Co., Stafford, Conn. (W) 80.  
 Phoenix Woolen Mills, Lexington, Ky. (W & K) 160.  
 Phyllis Knitting Co., Chicago, Ill. (K) 95.  
 Piazcek Woolen Mill, Valley Falls, Kansas (W) 100.  
 Pickering, J. C., Barnstead, N. H. (W & K) 143.  
 Pickering Mfg. Co., Lowell, Mass. (K) 123.  
 Picton Mills (Chas. R. Simister) 226.  
 Piedmont Cotton Mills, Atlanta, Ga. (C) 85.  
 Piedmont Mfg. Co., Piedmont, S. C. (C) 267.  
 Piedmont Mfg. Co., Portsmouth, Va. (K) 278.  
 Pierce, Chas. B., Otto, N. Y. (W) 179.  
 Pierce Mfg. Corp., New Bedford, Mass. (C) 126.  
 Pike, C. W., Dodge, Mass. (W) 115.  
 Pike, E. V., Cheithenham, Pa. (S) 235.  
 Pilling Mfg. Co., Philadelphia, Pa. (K) 224.  
 Pilling & Madeley, Philadelphia, Pa. (K) 224.  
 Pilot Cotton Mills, Raleigh, N. C. (C) 193.  
 Pine Tree Silk Mills Co., Philadelphia, Pa. (S) 224.  
 Pioneer Buffalo Coat Mfg. Co., Detroit, Mich., and Defiance, O. (W & K) 137, 199.  
 Pioneer Knitting Mills (A. West) 244.  
 Pioneer Knitting Mills Co., The, Hamilton, O. (K) 199.  
 Pioneer Knitting Works (J. H. Guzman) 99.  
 Pioneer Mills (James F. Townsend) 146.  
 Pioneer Silk Factory, San Francisco, Cal. (S) 72.  
 Pioneer Woolen Mills (Robert Dobson & Co.) 106.  
 Piqua Hosiery Co., The, Piqua, O. (K) 200.  
 Piscataquis Woolen Co., Guilford, Me. (W) 103.  
 Pitcher, A. P. Co., Melleville, N. Y. (K) 172.  
 Pitkin, Holdsworth Worsted Co. (Passaic Worsted Mills and Manhattan Worsted Mills) 153, 176.  
 Pitman Mfg. Co., Laconia, N. H. (K) 145.  
 Pitton Bros., Cincinnati, O. (D) 198.  
 Pitts, James & Son, Millville, Mass. (W) 125.  
 Pittsburg Textile Mfg. Co., Pittsburg, Texas (W) 372.  
 Pittsburg Waste Co., Pittsburg, Pa. (W) 243.  
 Pittsfield Mfg. Co., Pittsfield, Mass. (W & K) 129.  
 Pittsfield Mills, Pittsfield, N. H. (C) 147.  
 Plaidville Mfg. Co., Randleman, N. C. (C) 194.  
 Plainfield Woolen Co., Central Village, Conn. (W) 72.  
 Plainville Mfg. Co., Plainville, Conn. (K) 78.  
 Plaisted & Barton (Park Knitting Works) 75.  
 Planet Mills (Planet Mills Mfg. Co.) 165.  
 Planet Mills Mfg. Co., Wilmington, Del., and Brooklyn, N. Y. (J) 84, 165.  
 Plate & Clark (Prospect Knitting Mills) 165.  
 Platt, A. & Son, Philadelphia, Pa. (W & C) 224.  
 Platt Bros., Philadelphia, Pa. (W) 224.  
 Pleasant Vale Mills (Chas. C. Groat) 169.  
 Pleasant Valley Cotton Mill (Garner & Co.) 179.  
 Plewes, John, Monroe, Mich. (W) 138.  
 Pluckanin Mfg. Co., Pluckamin, N. J. (W & D) 158.  
 Plunkett, W. C. & Sons, Adams, Mass. (C) 109.  
 Plymouth Carding Mill (Robinson & Lamb) 106.  
 Plymouth Cordage Co., Plymouth, Mass. (J) 129.  
 Plymouth Woolen & Cotton Co., Plymouth, Mass. (C) 129.  
 Pocahontas Mills, Petersburg, Va. (C) 277.  
 Pocasset Mfg. Co., Fall River, Mass. (C) 118.  
 Poceaser Worsted Co., Thornton, R. I. (W) 260.  
 Poe, F. W., Mfg. Co., Greenville, S. C. (C) 265.  
 Poidebard Silk Mfg. Co., West Hoioken, N. J. (S) 160.  
 Pollack, M., Willimantic, Conn. (C) 83.  
 Pollitz, Kaufman & Co., Philadelphia, Pa. (C) 224.  
 Pollock, Jas., Philadelphia, Pa. (C & W) 224.  
 Pollock, James & Son, Philadelphia, Pa. (W) 224.  
 Pomeroy Woolen Co., Pittsfield, Mass. (W) 129.  
 Pond Lily Co., The, New Haven, Conn. (B1 & D) 77.  
 Pond Lily Warp Co., New Haven, Conn. (C & D) 77.  
 Pondcherry Co., Bridgton, Me. (W) 102.  
 PONDVILLE WOOLEN CO., Auburn, Mass. (W) 111.  
 Pontefract, James & Co., New Bethlehem, Pa. (K) 242.  
 Pontiac Bleachery, Pontiac, R. I. (B1) 257.  
 Pontiac Knit Boot Co., Pontiac, Mich. (K) 138.  
 Pontiac Knitting Co., Pontiac, Mich. (K) (See Too Late Classification List)  
 Pontiac Knitting Works Co., Pontiac, Mich. (K) 138.  
 Pontiac Mfg. Co., Pontiac, R. I. (C & B1) 257.  
 Pontoosuc Woolen Mfg. Co., Pittsfield, Mass. (W) 129.  
 Pool Bros., Blaine, W. Va. (W) 279.  
 Popular Hosiery Mills (Wm. F. Taubel) 159.



- Portage Hosiery Co., Portage, Wis. (K) 282.  
 Portage Underwear Mfg. Co., Portage, Wis. (K) 282.  
 Porter Mfg. Co., Cornelia, Ga. (C & W) 88.  
 Porter & Dickey, Philadelphia, Pa. (C) 224.  
 Porterdale Mills, Covington, Ga. (C) 88.  
 Portland Cordage Co., Portland, Ore. (F1) 201.  
 Portland Silk Co., Middletown, Conn. (S) 76.  
 Portland Woolen Mills, Portland, Ore. (W) 201.  
 Portsmouth Knitting Mills, Portsmouth, Va. (K) 278.  
 Fosern, H., Philadelphia, Pa. (W & K) 224.  
 Fosnansky, Max., Hosiery Co., St. Louis, Mo. (K) 142.  
 Post Falls Woolen Mill Co., Post Falls, Idaho (W & K) 92.  
 Post & Sheldon, Dover, Del., and Paterson, N. J. (S) 83, 157.  
 Potomask Mills, New Bedford, Mass. (C) 126.  
 Potts, O. A. Co., Pittsburg, Pa. (K) 243.  
 Potts & Durkin, Paterson, N. J. (S) 157.  
 Pottstown Knitting Co., Pottstown, Pa. (K) 244.  
 Powell, Chas. A. (Alliance Ktg. Mills) 184.  
 Powell River Woolen Mill (Farrar & White) 276.  
 Powell & Bro., Philadelphia, Pa. (K) 224.  
 Powhatan Mills, Putnam, Conn. (C) 79.  
 Powhattan Mills (Esrey Mfg. Co., Ltd.) 235.  
 Prairie Du Chien Woolen Mill Co., Prairie Du Chien, Wis. (W) 282.  
 Pranker Mill (Saugus Wln. Mfg. Co.) 130.  
 Prattville Cotton Mills & Banking Co., Prattville, Ala. (C) 69.  
 Premier Cotton Mills, Helena, Ark. (C) 71.  
 Premier Hosiery Mills, St. Louis, Mo. (K) 142.  
 Prendergast, Wm. H., Bridgeton, R. I. (W) 251.  
 Prescott, A. M. (Buttonwood Shoddy Mill) 134.  
 Preston & Mackey (Chataqua Towel Mills) 170.  
 Price, The H. W. Co., Rockford, Ill. (K) 96.  
 Prince, S. L., Philadelphia, Pa. (W) 224.  
 Princeton Mfg. Co., Athens, Ga. (C) 85.  
 Pritchett, H. & Co., Madisonville, Ky. (W) 101.  
 Proctor, James, Genesee Depot, Wis. (W) 281.  
 Proctorsville Mills, Proctorsville, Vt. (W) 275.  
 Progress Mill (Richard Hey & Son) 217.  
 Progress Mill (John Warner's Sons) 163.  
 Progressive Knitting Mills, Detroit, Mich. (K) 137.  
 Prospect Dye Works, Reading, Pa. (D) 245.  
 Prospect Knitting Mills, Brooklyn, N. Y. (K) 165.  
 Prospect Worsted Mills, Lawrence, Mass. (W) 122.  
 Providence Cotton Mills, Maiden, N. C. (C) 192.  
 Providence Dyeing, Bleaching & Calendering Co., Providence, R. I. (B1, D & F) 258.  
 Providence Dyeing & Finishing Works (Firth & Foster Co.) 215.  
 Providence Mills Mfg. Co., Philadelphia, Pa. (C) 224.  
 Providence Woolen Mills (Daniel Turner) 108.  
 Provo Woolen Mill Co., Provo City, Utah (W) 273.  
 Proximity Mfg. Co., Greensboro, N. C. (C) 190.  
 Prue, Frank J. & Co., Woonsocket, R. I. (K) 261.  
 Pulaski Woolen Mill, Pulaski, Tenn. (W) 271.  
 Pulaski Woolen Mills (Mahoffy Bros) 179.  
 Puritan Knitting Mill, Everett, Mass. (K) 116.  
 Puritan Woolen Mills, Plymouth, Mass. (W) 129.  
 Puritan Worsted Mills, Providence, R. I. (W) 258.  
 Purple, A. E., Moodus, Conn. (C) 76.  
 Putnam, George (Batesville Mill) 265.  
 Putnam Mfg. Co., Putnam, Conn. (C) 79.  
 Putnam Mills (The Artman, Treichler Carpet Co.) 203.  
 Putnam Woolen Co., Putnam, Conn. (W) 79.  
 Pynes, J. H., Waterford, N. Y. (K) 183.  
 Quaker City Dye Works Co., Philadelphia, Pa. (D) 224.  
 Quaker City Knitting Co., Woodbine, N. J. (K) 160.  
 Quaker City Mills (James Connelly & Sons) 211.  
 Quaker City Mills (The Long Bros. Co.) 220.  
 Quaker City Textile Mills (Joseph H. Masland Co.) 221.  
 Quakertown Silk Co., Quakertown, Pa. (S) 244.  
 Queen City Cotton Co., Burlington, Vt. (C) 275.  
 Queen City Knitting Mills, Elmira, N. Y. (K) 168.  
 Queen City Twine Mills, Cincinnati, Ohio (J) 197.  
 Queen Dyeing Co., Providence, R. I. (D & F) 258.  
 Queensbury Mills, Worcester, Mass. (W) 134.  
 Querns Bros., Philadelphia, Pa. (K) 224.  
 Quidnick Mfg. Co., Anthony, R. I. (C) 251.  
 Quincy Knitting Co., Three Rivers, Mich. (K) 129.  
 Quinebaug Co., Danielson, Conn. (C) 73.  
 Quinlan, John & Co., Milford, N. H. (B1) 146.  
 Quinn, John F. (Pearl Knitting Mills) 167.  
 Quinn Mfg. Co., The, Petersburg, Va. (C) 277.  
 Quintette Mfg. Co., Eatonton, Ga. (C) 88.  
 Raccoon Mfg. Co., Raccoon Mills, Ga. (C) 91.  
 Racine Knitting Co., Beloit, Racine and Stevens Point, Wis. (K) 280, 282.  
 Racine Woolen Mills, Peru, Ind. and Racine, Wis. (W) 98, 282.  
 Radcliffe Bros., Shelton, Conn. (K) 79.  
 Radcliffe, C. E., Long Hill, Conn. (K) 76.  
 Radcliffe, Wm., Dedham, Mass. (K) 115.  
 Radcliffe & Shaw, Glen Rock, Pa. (J) 238.  
 Radford Woolen Mfg. Co., Radford, Va. (W) 273.  
 Radley, A., Philadelphia, Pa. (W & J) 224.  
 Radmoor Mill (Thomas E. Brown & Son) 207.  
 Railway Supply & Mfg. Co., The, Cincinnati, Ohio (C & W) 198.  
 Rainbow Dye Works (Haslam & Querner) 217.  
 Rainbow Knitting Mills (Harry W. Thurman) 228.  
 R. A. Knitting Mills (J. C. Roulette & Co.) 108.  
 Raleigh Cotton Mills, Raleigh, N. C. (C) 194.  
 Raleigh Hosiery Co., Raleigh, N. C. (K) 194.  
 Raleigh Woolen Mill (Spangler & Turrow) 279.  
 Raleigh's Mills (Jos. Adamson & Co.) 202.  
 Rambo & Regar, Norristown, Pa. (K) 242.  
 Rammelt, C. F. (Franksville Tow Co.) 281.  
 Ramsay & Gore Mfg. Co., Paterson, N. J. (S) 157.  
 Ramshorn Mills, West Millbury, Mass. (W) 133.  
 Randall, E. E., Canastota, N. Y. (K) 166.  
 Randall, Joseph & Bro., Philadelphia, Pa. (W) 224.  
 Randleman Hosiery Mills, Randleman, N. C. (K) 194.  
 Randleman Mfg. Co., Randleman, N. C. (C) 194.  
 Randolph Mfg. Co., Franklinville, N. C. (C) 189.  
 Randolph Mills (J. W. Landenberger & Co.) 220.  
 Ponemah Mills, Taftville, Conn. (C) 80.  
 Ponogansett Mill, Rockland, R. I. (C) 259.  
 Ranke, Franz, Frankenmuth, Mich. (W & K) 137.  
 Rappahannock Woolen Mills Co., Laurel Mills, Va. (W) 277.  
 Raritan Woolen Mills, Raritan, N. J. (W) 159.  
 Rath, H., Jr., Philadelphia, Pa. (W) 224.  
 Rauchenberger, John, Co., Milwaukee, Wis. (J) 282.  
 Ravine Mills Co., Vernon, Conn. (C) 81.  
 Rawitser & Bro., Meriden, Mystic, Stafford Springs and Staffordville, Conn. (W) 76, 77, 80.  
 Rawitser, S. & Co., Brooklyn, N. Y. (W) 165.  
 Ray Fabric Mills, Franklin, Mass. (W) 119.  
 Ray H. P., (Manchester Stocking Co.) 146.  
 Ray Mills, Franklin, Mass. (W) 119.  
 Ray & Wilson, Medway, Mass. (C) 124.  
 Read Carpet Co., Bridgeport, Conn. (W) 73.  
 Read, Ed. C., Philadelphia, Pa. (W) 225.  
 Read, Wm. F., Philadelphia, Pa. (W & S) 225.  
 Read & Lovatt Co., The, Elmira, N. Y. and Weatherly, Pa. (S) 168, 249.  
 Readfield Woolen Mills, Readfield, Maine (W) 106.  
 Reading Braid Co., Reading, Pa. (W & S) 245.  
 Reading Cordage Works (Thos. Jackson & Son) 245.  
 Reading Cotton Batting Co., Mohrsville, Pa. (C) 241.  
 Reading Cotton Mill (Garner & Co.) 244.  
 Reading Glove & Mitten Co., Reading, Pa. (K) 245.  
 Reading Hosiery Co., Reading, Pa. (K) 245.  
 Reading Knitting Mills, Reading, Pa. (K) 245.

- Reading Industrial Works Co., Reading, Pa. (C) 245.
- Reading Underwear Co., Reading, Pa. (K) 245.
- Reading Woolen Mill (J. G. Leinbach & Co.) 245.
- Readville Cotton Mills (Robt. Knight) 129.
- Reams, David, Du Bois, Pa. (K) 237.
- Reber, John, Pottsville, Pa. (K) 234.
- Red Bank Mills (Fawcett Bros.) 244.
- Red River Mills (McCracken, R. W. & J. D.) 100.
- Red Star Dye Works (John W. Carson) 209.
- Reddick, W. H. & Co., Dalton, Mass. (W) 115.
- Reed City Woolen Mills (Wm. Lambert) 135.
- Reed & Leininger, Schuylkill Haven, Pa. (K) 246.
- Reedsburg Woolen Mills Co., Reedsburg, Wis. (W) 282.
- Reedy River Mfg. Co., Reedy River Factory, S. C. (C) 267.
- Reems Creek Wln. Mills Co., Weaverville, N. C. (W) 196.
- Rees & Rees, New York, N. Y. (D & F) 177.
- Reetz, Ewald R., Hulmeville, Pa. (C) 229.
- Regal Textile Co., Utica, N. Y. (K) 182.
- Regal Worsted Mills, Providence, R. I. (W) 258.
- Regan, Jas. J. Mfg. Co., The, Rockville, Conn. (C, W & K) 79.
- Reichman, Wm., New York, N. Y. (K) 177.
- Reid, Graham & Co., Philadelphia, Pa. (K) 225.
- Reid & Barry Works, Passaic, N. J. (Pr. D & F) 153.
- Reiling, David & Schoen, Weehawken, West Hoboken, N. J.; Dunmore, Altoona, Pa.; Valley Falls, R. I. (S) 159, 160, 237, 247, 260.
- Reinach, A. S. & Son (Petersburg Hosiery Co.) 277.
- Reinhardt, F. C., Paterson, N. J. (S) 157.
- Reliable Knitting Works (J. M. Behrman) 93.
- Reliance Hosiery Mills, Gettysburg, Pa. (K) 238.
- Reliance Mfg. Co., Wilmington, Del. (W) 84.
- Reliance Textile and Dye Works, Covington, Ky. (D & F) 100.
- Reliance Worsted Co., Woonsocket, R. I. (W) 261.
- Remsen, George W. & Co., Wilkesbarre, Pa. (D) 250.
- Renard & Co., Taylor, Pa. (S) 248.
- Renfrew Mfg. Co., Adams, Mass. (C) 109.
- Reshower, Joseph & Co., New York, N. Y. (S) 177.
- Ressler & Co. (Shamokin Valley Knitting Mills) 247.
- Rettger-Allen Co., Paterson, N. J. (S) 157.
- Revolution Cotton Mills, Greensboro, N. C. (C) 190.
- Reynolds, H. E., Aberdeen, Miss. (C) 140.
- Reynolds Mfg. Co., Davisville, R. I. (W) 253.
- Reynolds, Solomon, Glenville, Conn. (W) 75.
- Reynoldsville Woolen Co., The, Reynoldsville, Pa. (W) 246.
- Rheinstrom, B. A., Philadelphia, Pa. (S) 225.
- Rhode Island Electrical Works, Pawtucket, R. I. (C) 257.
- Rhode Island Worsted Co., Indian Orchard, Mass. (W) 121.
- Rhodes Bros., Ltd., Aston Mills, Pa. (W) 233.
- Rhodes Warp Co., John, Millbury, Mass. (C) 125.
- Rhodesia Mfg. Co., Philadelphia, Pa. (W) 225.
- Rhodhiss Mfg. Co., Granite Falls, N. C. (C) 189.
- Rhyme, A. P. (Albion Co.) 193.
- Rhyme, A. P. & Co. (Mt. Holly Cotton Mills) 193.
- Rhyme, D. E. (Laboratory Cotton Mills) 192.
- Rialto Mills (Simons & Struve Hosiery Co.) 226.
- Rice, A. H. & Co., Pittsfield, Mass. (S) 129.
- Rice, Clayton G., Philadelphia, Pa. (C & W) 225.
- Rice, E., St. Paul, Minn. (K) 140.
- Rice & Love (Concord Woolen Mill) 90.
- Rich, John & Bros., Oak Grove and Woolrich, Pa. (W & K) 242, 250.
- Rich, John S., Millbury & Oxford, Mass. (W) 125, 128.
- Rich, N. J. & Co., Cleveland, O. (K) 198.
- Richardet, Chas. L. (Special Knitting Works) 137.
- Richards, Dexter, Sons, Newport, N. H. (W) 146.
- Richards, Fred J., Springfield, Mass. (C) 131.
- Richardson Silk Co., Belding, Mich. (S) 137.
- Richardson, Weir & Co. (Westmoreland Dye Works) 229.
- Richardson & Pease, Marlboro, N. H. (W) 146.
- Richardson & Ross Mfg. Co., Chester, Pa. (W & C) 235.
- Richelieu Knitting Co., Utica, N. Y. (K) 182.
- Richfield Springs Scotch Cap Co., Richfield Springs, N. Y. (K) 179.
- Richland Cotton Mills, Columbia, S. C. (C) 263.
- Richmond Cotton Factory, Laurel Hill, N. C. (C) 191.
- Richmond Dyeing & Printing Works (James Martin & Co.) 221.
- Richmond Flax Mills, Richmond, Ind. (F) 98.
- Richmond Hosiery Mills, Rossville, Ga. and Chattanooga, Tenn. (K) 91, 269.
- Richmond Hosiery Mills (E. Sutro & Sen) 227.
- Richmond Mfg. Co., Bristol, R. I. (C) 251.
- Richmond Mfg. Co., Stapleton, N. Y. (W) 181.
- Richmond Mill (Joslin Mfg. Co.) 259.
- Richmond Spinning Co., Chattanooga, Tenn. (C) 269.
- Richmond Woolen Mill, Richmond, Mich. (W) 138.
- Richter, J. B., Sedalia, Mo. (K) 142.
- Richter Mfg. Co., Tenafla, N. J. (C) 159.
- Ricker & Logan, Philadelphia, Pa. (W) 225.
- Ridley Mill, Clifton Heights, Pa. (W) 236.
- Rief, Geo. W. (Bicycle Hosiery Co.) 146.
- Riegelman & Co., New York, N. Y. (S) 177.
- Rigg, J. W., Son & Co. (Terra Alta Woolen Mills) 280.
- Riggles, W. B. & W. F., Olympia, Va. (W) 277.
- Riley, Edward, Paterson, N. J. (D) 157.
- Rinehart, H. P., Philadelphia, Pa. (W) 225.
- Ring, Jonathan & Son, Phila., Pa. (W) 225.
- Rings & Beach (Unity Mill Co.) 201.
- Ringtown Knitting Co., Ringtown, Pa. (K) 246.
- Rininger, Wm. L. & Sons, Stoyestown, Pa. (W) 248.
- Rionor Silk Mills, Allentown, Pa. (S) 231.
- Rio Virzen Mills, Washington, Utah (C & W) 273.
- Ripka Mills (Southwark Mills Co.) 227.
- Ripon Knitting Works, Ripon, Wis. (K) 282.
- Ripon Underwear Co., Ripon, Wis. (C) 282.
- Ritche, Robt. J. & R. Co., Phila., Pa. (S) 225.
- River Mills (Rawtser & Bro.) 80.
- River Mills, Otter River, Mass. (W) 128.
- River Spinning Co., Woonsocket, R. I. (W) 261.
- River View Worsted Mills, Waterville, Maine (W) 107.
- Riverdale Carpet Mills (Lawrence Collins) 211.
- Riverdale Cotton Mills, Riverview, Ala. (C) 69.
- Riverdale Mills, Great Barrington, Mass. (C) 119.
- Riverdale Woolen Co., Northbridge, Mass. (W) 128.
- Riverside Cotton Mills, Danville, Va. (C) 276.
- Riverside Hosiery Mills (Christian Dick) 159.
- Riverside Knitting Mill (Howard & Buck) 166.
- Riverside Knitting Mill, Cohoes, N. Y. (K) 167.
- Riverside Knitting Mills (Rugene Walrath) 171.
- Riverside Knitting Mills Co., New York, N. Y. (K) 177.
- Riverside Mfg. Co., Anderson, S. C. (C) 262.
- Riverside Mills, Augusta, Ga. (C) 86.
- Riverside Mills, Providence, R. I. (W) 258.
- Riverside Silk Co., Paterson, N. J. (S) 157.
- Riverside Woolen Co., Pittsfield, Me. (W) 106.
- Riverside Woolen Co., Stafford, Conn. (W) 80.
- Riverside Woolen Mills (W. T. Parham & Sons) 270.
- Riverview Knitting Mills, Tarboro, N. C. (K) 195.
- Rivulet Mills (Richard Sayles & Co.) 132.
- Roane Woolen Mill, Post Oak Springs, Tenn. (W) 271.
- Roanoke Cotton Mill, Roanoke, Va. (C) 278.
- Roanoke Mills Co., Roanoke, N. C. (C & K) 194.
- Rob Roy Hosiery Co., Troy, N. Y. (K) 182.
- Robbins, John, Wool Scouring Co., Las Vegas, New Mex. (W) 160.
- Roberdel Mfg. Co., Rockingham, N. C. (C) 194.
- Roberts, A. & Co., Claremont, N. H. (W) 143.
- Roberts, Chas. E., Paterson, N. J. (S) 157.
- Roberts, James, Newark, Del. (W) 83.

- Robertsford Worsted Mills, Passaic, N. J. (W) 154.  
 Robertshaw, A. L. Co., Philadelphia, Pa. (W) 225.  
 Robertson Mfg. Co., Staley, N. C. (C) 195.  
 Robeson Mills, Fall River, Mass. (C) 118.  
 Robesonia Knitting Mills (Leinbach & High) 246.  
 Robinson, E. Jay, Fastport, N. Y. (C) 168.  
 Robinson, Fred'k, New Brunswick, N. J. (K) 153.  
 Robinson, F. F. (Ideal Knitting Works) 180.  
 Robinson, J. H. (Paoli Bleach Works) 223.  
 Robinson Mfg. Co., Oxford, Maine (W) 106.  
 Robinson Mills, South Windham, Maine (W) 107.  
 Robinson & Lamb, Plymouth, Maine (W) 106.  
 Rochdale Mills (Titus Flannel Co.) 179.  
 Rochdale Woolen Mills (A. Howarth & Son) 130.  
 Rochester Batting Mills, Rochester, N. Y. (C) 180.  
 Rochester Knitting Works (Max Lowenthal & Bro.) 180.  
 Rochester Textile Works, Rochester, N. H. (C) 180.  
 Rochester Woolen Co., Rochester, N. H. (W) 147.  
 Rochester Woolen Mfg. Co., Rochester, Minn. (W) 140.  
 Rock Carpet Mills (Swire & Scott) 228.  
 Rock City Hosiery Mill (Leo Kaufman & Co.) 270.  
 Rock Hill Mill (John Dobson) 213.  
 Rock, Jas. E. (Niagara Falls Hair Cloth Works) 178.  
 Rock Mfg. Co., Rockville, Conn. (W) 79.  
 Rock Mill (Jansen & Pretzfeld) 156.  
 Rock River Cotton Co., Janesville, Wis. (C) 281.  
 Rock River Woolen Mills, Janesville, Wis. (W) 281.  
 Rockdale Mill, Northbridge, Mass. (C) 128.  
 Rockfall Woolen Co., Middletown, Conn. (W) 76.  
 Rockford Cotton Mills (McElwell & Co.) 271.  
 Rockford Cotton Mills, Rockford, Ill. (C) 96.  
 Rockford Mitten & Hosiery Co., Rockford, Ill. (K) 96.  
 Rockford Woolen Mill (F. J. Benner) 140.  
 Rockingham Mills, No. Salem, N. H. (W) 146.  
 Rockland Bleach & Dye Works Co., Brooklandville, Md. (B1 & D) 108.  
 Rockland Mill (Joslin Mfg. Co.) 259.  
 Rockland Print Works, Garnerville, N. Y. (Fr) 169.  
 Rockland Webbing Co., Rockland, Mass. (C) 130.  
 Rockport Woolen Mills, Rockport, Ind. (W) 98.  
 Rockstone Mills, Downingtown, Pa. (W) 237.  
 Rockton Knitting Mills, Little Falls, N. Y. (K) 171.  
 Rockville Warp Mills Co., Rockville, Conn. (C) 79.  
 Rockwell, C. W. & Co., Rockwell's Mills, N. Y. (W) 180.  
 Rockwell, E. M., Leominster, Mass. (W) 122.  
 Rockwell, Jno. E., Canton, Pa. (W) 234.  
 Rockwell & Rockwell, Hornellsville, N. Y. (S) 170.  
 Rockwood, Geo. & Co., Bennington, Vt. (K) 273.  
 Rocky Mount Mills, Rocky Mount, N. C. (C) 194.  
 Rodger, Andrew Y., Lowell, Mass. (C & S) 123.  
 Rodger, Wm. M. & Co., Lowell, Mass. (C & S) 123.  
 Rodman Heath Cotton Mill, Waxhaw, N. C. (C) 196.  
 Rodman Mfg. Co., Allenton and Laffayette, R. I. (W) 251, 254.  
 Roelofs, Henry Co., Philadelphia, Pa. (W) 225.  
 Reessel, Louis & Co., Washington, N. J. and Hazelton, Pa. (S) 159, 229.  
 Roff, Isaac (Green Island Knitting Mills) 169.  
 Rogers, E. W. & Sons, Lockport, N. Y. (C) 171.  
 Rogers, Wm. & Co., Philadelphia, Pa. (S) 225.  
 Rolle, Aug. J., College Point, N. Y. (S) 168.  
 Romberger, C. M. & Co., Georgetown, Pa. (K) 228.  
 Romberger, H. A., Middletown and Newport, Pa. (K) 241, 242.  
 Rome Cotton Factory, Rome, Ga. (C) 91.  
 Rome Steam Knitting Mills (Williams Bros.) 180.  
 Rome Textile Co., Rome, N. Y. (K) 180.  
 Roosevelt Worsted Mill, Philadelphia, Pa. (W) 225.  
 Root, C. A. & Co., Uxbridge, Mass. (W) 132.  
 Root Mfg. Co., Cohoes, N. Y. (K) 167.  
 Rope and Yarn Mills, Tuscaloosa, Ala. (C) 70.  
 Roper Bros. & Co., Highlandville, Mass. (K) 120.  
 Rose, G. H., Malden, Mass. (K) 124.  
 Rose Glen Mills (Booth & Bro.) 238.  
 Rose Hill Silk Works (J. G. Irving) 73.  
 Rose, James & Son, Philadelphia, Pa. (W) 225.  
 Rose Silk Manufacturing Co., Paterson, N. J. (S) 157.  
 Rosemary Knitting Mills, Williston, S. C. (K) 268.  
 Rosemary Mfg. Co., Roanoke Rapids, N. C. (C) 194.  
 Rosenau Hosiery Mills, Tuscaloosa, Ala. (K) 70.  
 Rosenau, S. & Co., Philadelphia, Pa. (S) 225.  
 Rosenau & Loeb, Philadelphia, Pa. (K) 225.  
 Rosenberg, L. R. & J. H. Loudon, Monson and Wales, Mass. (W) 125, 132.  
 Rosenberger, J. W. & Son, Harrisburg, Pa. (W) 238.  
 Rosenfeld, M. & Co., Brooklyn, N. Y. (S) 165.  
 Rosenfeld & Jonas, New York, N. Y. (S) 177.  
 Rosenfeld & Co., New York, N. Y. (K) 177.  
 Rosenhayn Ktg. Mills (L. M. Schiendelman) 177.  
 Rosenhelm Bros. & Co., Philadelphia, Pa. (C) 225.  
 Roside Fabric Company, Hillsdale, N. J. (S) 151.  
 Ross, E. J. Mfg. Co., Port Oram, N. J. (S) 158.  
 Ross, J. Alex. & Co., Craigsview, Pa. (W) 236.  
 Ross, John L. (Eagle Mill) 75.  
 Ross, Richard, Allentown, Pa. (D) 231.  
 Ross Textile Mfg. Co., Madison, Ind. (W) 97.  
 Ross & Browne Wool Scouring Co., Las Vegas, New Mexico (W) 160.  
 Rossendale-Reddaway Belting & Hose Co., The, Newark, N. J. (C) 152.  
 Rossie Velvet Co., Mystic, Conn. (S) 77.  
 Rossiter, J. S. & Co., Chicago, Ill. (K) 95.  
 Rossmann Knitting Co., N. Y. (K) 180.  
 Roswell Mfg. Co., Roswell, Ga. (C) 91.  
 Rotch Spinning Corp., New Bedford, Mass. (C) 126.  
 Roth, Jos. & Co., Toledo, O. (K) 200.  
 Rotherwood Woolen Mills (C. N. Jordan) 271.  
 Rothstein, N., New York, N. Y. (S) 177.  
 Roulette, J. C. & Co., Hagerstown, Md. (K) 108.  
 Rowan, W. S. (Chillicothe Hosiery Mill) 197.  
 Rowe, F. B. & Co., Laconia, N. H. (K) 145.  
 Rowe Knitting Co., Huntsville, Ala. (K) 69.  
 Rowe, W. H., Knitting Co., Amsterdam, N. Y. (K) 161.  
 Rowe & Best, Amsterdam, N. Y. (K) 161.  
 Rowe & Co., Laconia, N. H. (W) 145.  
 Rowland, Samuel, Schuylkill Haven, Pa. (B1 & D) 246.  
 Roxboro Cotton Mills, Roxboro, N. C. (C) 194.  
 Roxboro Mill Co., Philadelphia, Pa. (D & B) 225.  
 Roxborough Mill (G. L. James) 218.  
 Roxbury Carpet Co., Boston, Mass. (W) 113.  
 Roxford Knitting Co., Philadelphia, Pa. (K) 225.  
 Roy, Jas. & Co., Watervliet, N. Y. (W) 184.  
 Roy, Rob. Hosiery Co., Troy, N. Y. (K) 182.  
 Royal Bag & Yarn Mfg. Co., Charleston, S. C. (C) 262.  
 Royal Braid Co., Williamsport, Pa. (C) 250.  
 Royal Knitting Co., Chester, Ill. (K) 93.  
 Royal Knitting Co., Johnstown, N. Y. (K) 171.  
 Royal Knitting Mills (J. F. Bast) 246.  
 Royal Knitting Mills (Hull, Smith & Co.) 161.  
 Royal Knitting Works, The, Chicago, Ill. (K) 95.  
 Royal Mills, St. Johnsville, N. Y. (K) 181.  
 Royal Mills, River Point, R. I. (C) 259.  
 Royal River Mfg. Co., Yarmouth, Me. (C) 167.  
 Royal Tapestry Co., Front Royal, Va. (W) 277.  
 Royal Weaving Co., Pawtucket, R. I. (C, W & S) 257.  
 Royal Worsted Mills, Harrisville, R. I. (W) 254.  
 Royal Cotton Mills, Wake Forest, N. C. (C) 196.  
 Royer's Ford Dye Works, Royer's Ford, Pa. (D & B) 246.  
 Ruderman, R., Brooklyn, N. Y. (K) 165.  
 Rudisill Mfg. Co., John, Lincolnton, N. C. (C) 192.  
 Rudolph, Otto, Brooklyn, N. Y. (K) 165.

- Rumford Falls Woolen Mills, Rumford Falls, Me. (W) 106.
- Rumpf's, Frederick, Sons, Attleboro, Pa. (C) 233.
- Rumsey Wool Stock Co., Detroit and Rochester, Mich. (W) 137, 138.
- Runnymede Hosiery Mills, Tarboro, N. C. (K) 195.
- Runnymede Worsted Mills, Clifton Heights, Pa. (W) 236.
- Rushford Ktg. Mills, Rushford, Minn. (K) 140.
- Rushton Cotton Mills, Griffin, Ga. (C) 89.
- Rusk County Cotton Mills, Henderson, Texas (C) 272.
- Russell Knitting Co., Chicopee, Mass. (K) 114.
- Russell Mfg. Co., Middletown, Conn. and North Wales, Pa. (C) 76, 243.
- Russell Mfg. Co., Winder, Ga. (K) 92.
- Russell Mfg. Co., The, Alexander City, Ala. (K) 67.
- Russell Mfg. Co., S. N. & C., Pittsfield, Mass. (W) 129.
- Russell, Wm. C., Oxford, Pa. (W) 243.
- Ruth, S. S., Womelsdorf, Pa. (K) 250.
- Rutholt Dye Works, Philadelphia, Pa. (D) 225.
- Rutledge, Wm. & Son, West Milton, Ohio (W) 201.
- Rutter Bros., Lawrence, Mass. (W) 122.
- Ryan Bros. Knitting Co., Detroit, Mich. (K) 137.
- Ryan, D. V. & Co., Paterson, N. J. (S) 157.
- Ryer, Jas. B. Son & Co., Paterson, N. J. (S) 157.
- Ryle, Wm. & Co. (Newton Mills) 127.
- Sackett Wired Tag Co., Garden Prairie, Ill. (C) 95.
- Sacks, Meyer H., New York, N. Y. (S) 177.
- Saco River Woolen Mills, West Buxton, Me. (W) 107.
- Saeltzer Woolen Co., Cleveland, O. (W) 198.
- Safety Seamless Pocket Co., Taunton, Mass. (C) 131.
- Sagamore Knitting Co., Mechanicsville, N. Y. (K) 172.
- Sagamore Mfg. Co., Fall River, Mass. (C) 118.
- Sager, A., Syracuse, N. Y. (K) 181.
- Sager Bros., Syracuse, N. Y. (K) 181.
- St. Croix Shoe Co., Calais, Me. (W) 102.
- St. Joseph Spinning & Knitting Works (Cooper, Wells & Co.) 139.
- St. Lawrence Mill (A. J. Brumbach) 244.
- St. Leger Mills, Philadelphia, Pa. (W) 227.
- St. Louis Cordage Co., St. Louis, Mo. (J) 142.
- St. Mary's Woolen Mfg. Co., St. Mary's, O. (W) 200.
- St. Vincent Industrial School, Utica, N. Y. (K) 182.
- Salem Knitting Mills (John P. Sheppard) 159.
- Salem Waste Co., Salem, Mass. (C) 130.
- Salisbury Cotton Mills, Salisbury, N. C. (C) 194.
- Salisbury, H. K. & Son (Erie Knitting Mill) 163.
- Salisbury Hosiery Mills, Salisbury, N. C. (K) 194.
- Salmon Falls Mfg. Co., Salmon Falls, N. H. (C) 147.
- Salmon, Wm., Westfield, Mass. and New York, N. Y. (C & S) 133, 177.
- Salt Lake Silk Factory (John Lyle) 273.
- Salt's Textile Mfg. Co., The, Bridgeport, Conn. (S & C) 72.
- Salter Silk Co., West Winsted, Conn. (S) 83.
- Samoset Co., Valley Falls, R. I. (C) 260.
- Samson Cordage Works, Shirley, Mass. (C) 130.
- San Jose Woolen Mill Co., San Jose, Cal. (W & K) 72.
- San Quentin Jute Factory, San Quentin, Cal. (J) 72.
- Sands, C. L. & Co., Mordansville, Pa. (W) 241.
- Sand, John A., Chicago, Ill. (K) 95.
- Sanders, H. A. (Richmond Mfg. Co.) 181.
- Sanderson, Lyman M., Whately, Mass. (C) 134.
- Sandy Hook Woolen Co., Sandy Hook, Conn. (W) 79. (See also Too Late for Classification List.)
- Sandy Lake Woolen Mills (J. M. Scharffer) 246.
- Sanford Cotton Mills, Sanford, N. C. (C) 195.
- Sanford Mills, Sanford, Me. (W) 106.
- Sanford Narrow Fabric Co., New York, N. Y. (C) 177.
- Sanford Spinning Co., Fall River, Mass. (C) 118.
- Sanford, Stephen & Sons, Amsterdam, N. Y. (W & C) 163.
- Sangerville Woolen Co., Sangerville, Me. (W) 106.
- Sanitary Dyeing Co., Reading, Pa. (D. Bl & Pr) (See Too Late Classification List.)
- Sankanac Mills (Johnson, Cowdin & Co.) 243.
- Santa Rosa Woolen Mills, Santa Rosa, Cal. (W) 72.
- Saperstein, Mr. Paterson, N. J. (S) 157.
- Saranac Mills, Blackstone, Mass. (W) 111.
- Saranac Mills, Philadelphia, Pa. (S) 225.
- Saratoga Hosiery Mills (R. & H. Newland) 181.
- Saratoga Victory Mfg. Co. (Victory Mills, N. Y. (C) 183.
- Sarfert, Max, Philadelphia, Pa. (D) 225.
- Sargent, E., Paterson, N. J. (S) 157.
- Saugus Wln. Mfg. Co., Saugus, Mass. (W) 130.
- Saunders Cotton Mill, Saundersville, Mass. (C & S) 130.
- Sauquoit Silk Mfg. Co., Philadelphia, Bethlehem and Scranton, Pa., 225, 233, 247.
- Savage Mfg. Co., Savage, Md. (C) 109.
- Savannah Cotton Mills, Savannah, Ga. (C) 91.
- Sawyer, Henry S. (estate of) Colebrook, Conn. (C) 73.
- Sawyer Mills, Dover, N. H. (W) 143.
- Saxe-Gotha Mills, Irene, S. C. (C) 266.
- Saxon Dye Works, Philadelphia, Pa. (D) 225.
- Saxon Mills, Spartanburg, S. C. (C) 267.
- Saxonia Dress Goods Mills, Philadelphia, Pa. (W) 225.
- Saxonville Mill, Saxonville, Mass. (W) 130.
- Saxony Worsted Mills, Newton, Mass. (W) 127.
- Saxon, H. W., Sumner, Ill. (W) 96.
- Saxton's River Worsted Mill, Saxton's River, Vt. (W) 275.
- Sayer & Corwin, Paterson, N. J. (D) 158.
- Sayles, A. L. & Sons, Pascoag, R. I. (W) 255.
- Sayles Bleachery (F. A. Savles) 259.
- Sayles, F. A., Saylesville, R. I. (Bl & F) 259.
- Sayles, Fred L. Co., Pascoag, R. I. (W) 255.
- Sayles, Louis G., Dayville, Conn. (W) 73.
- Sayles, Richards & Co., Uxbridge, Mass. (W) 132.
- Sayles & Gilleran, Woonsocket, R. I. (W) 261.
- Sayles & Jenks Mfg. Co., Warren, Mass. (W) 133.
- Scanlon, John, Morrilton, Ark. (W) 71.
- Scanlin, John & Son, Philadelphia, Pa. (W) 225.
- Scarborough Mfg. Co., Philadelphia, Pa. (C & W) 225.
- Scatchard's, Joseph, Sons, Philadelphia, Pa. (W) 225.
- Schadewald, Henry, Philadelphia, Pa. (C) 225.
- Schaefer, L. B., Jersey City, N. J. (S) 151.
- Schaeffer, J. M., Sandy Lake, Pa. (W) 246.
- Schaghticoke Mills Co., Schaghticoke, N. Y. (W) 180.
- Schanz, Frank, Philadelphia, Pa. (D) 225.
- Schanzer, S., New York, N. Y. (K) 177.
- Schapiro, Z. & B., Brooklyn, N. Y. (K) 165.
- Scharg Bros., Carlstadt, N. J. (S) 149.
- Scatchard, Henry F., Mfg. Co., Norristown, Pa. (W) 242.
- Schau's, Julius Son, New York, N. Y. (S) 177.
- Scheck & Goodman, Philadelphia, Pa. (W) 225.
- Scheindelmann, Sam'l (Liberty Knitting Mills) 165.
- Scherr Bros., Philadelphia, Pa. (S) 225.
- Scheuer, A. & S., New York, N. Y. (S) 177.
- Scheuer, A. & S., New York, N. Y. (S) 177.
- Schiendelmann, L. M., New York, N. Y. (K) 177.
- Schiess, Theo., New York, N. Y. (S) 177.
- Schlager, C. J. (Wayne Co. Knitting Mills) 238.
- Schlatter & Sacks, Philadelphia, Pa. (S) 225.
- Schlegel Mfg. Co., Rochester, N. Y. (S) 180.
- Schlichter Jute Cordage Co., The, Phila., Pa. (J) 226.
- Schmid, F. J., New York, N. Y. (S) 177.
- Schmidt Bros. Mfg. Co., Paterson, N. J. (S) 158.
- Schmidt, Eugene (Hoboken Silk Dye Works) 151.
- Schmidt, Geo. & Bro., Philadelphia, Pa. (K) 226.
- Schneebeil, G. A. & Co., Nazareth, Pa. (C) 242.
- Schneider, J. S. (Suffolk Dye Works) 278.
- Schnitzler, B., New York, N. Y. (S) 177.
- Schoenfuss, F. J., Boston, Mass. (S) 113.
- Schofield, J. & Son, Madison, Ind. (W) 97.
- Schofield Mfg. Co., Macon, Ga. (K) 90.

- Schofield, Mason & Co., Philadelphia, Pa. (W) 226.
- Scholes, Wm., Philadelphia, Pa. (W) 226.
- Scholes, Wm. & Son, Philadelphia, Pa. (W) 226.
- Schofield, C. F., Montville, Conn. (W) 76.
- Schraack & Sherwood, Phila., Pa. (S) 226.
- Schuihoff Bros., Reading, Pa. (W) 245.
- Schultz Mfg. Co., Philadelphia, Pa. (S) 226.
- Schultz & Bro., Baltimore, Md. (W & J) 108.
- Schulze & Son, Eli (Liberty Dye Works) 245.
- Schum, Philip Son & Co., Lancaster, Pa. (W) 239.
- Schumacher, F. & Co., Paterson, N. J. (S) 157.
- Schumacher, Keller & Co., Ltd., Schuylkill Haven, Pa. (K) 246.
- Schurmann, Fred'k, New York, N. Y. (S) 177.
- Schuylkill Co. Prison, Pottsville, Pa. (W & K) 244.
- Schuylkill Woolen Mills (H. C. Jones Co.) 236.
- Schwarze, Julius, Whitestone, N. Y. (S) 184.
- Schwarze & Stern, New York, N. Y. (C, S & W) 177.
- Schwarzenbach, Huber & Co., Bayonne, West Hoboken, Weehawken, N. J. and Altoona, Hollidaysburg, Pa. (S) 148, 159, 160, 231, 239.
- Schwarzwaelder Co., The, Philadelphia, Pa. (F) 226.
- Schwelm, Jno. M. & Sons, Philadelphia, Pa. (W & S) 226.
- Schweigart, J., Philadelphia, Pa. (D) 226.
- Schweizer & Gsell (Eagle Printing Co.) 155.
- Sciota Mill (Wm. Spink) 227.
- Scotland Cotton Mills, Laurinburg, N. C. (C) 191.
- Scotland Neck Cotton Mills, Scotland Neck, N. C. (K) 195.
- Scott, Daniel, Philadelphia, Pa. (W) 226.
- Scott, F. & Son, Saugus, Mass. (W) 120.
- Scott, G. W., Investment Co. (Scottdale Mills) 85.
- Scott, J. Percy, Lexington, Ky. (F) 100.
- Scott, J. R. & C. W., Uxbridge, Mass. (W) 132.
- Scott, J. Wilson & Co., Philadelphia, Pa. (C & K) 226.
- Scott, S. F., Uxbridge, Mass. (W) 132.
- Scott, Walter & Co., Dexter, Me. (W) 163.
- Scottdale Mills, Atlanta, Ga. (C) 85.
- Scranton Lace Curtain Co., Scranton, Pa. (C) 247.
- Seaboard Knitting Mills, Henderson, N. C. (K) 190.
- Seabury & Johnson, East Orange, N. J. (C) 149.
- Seacoast Mills, Fall River, Mass. (C) 118.
- Seal Back Underwear Co., Utica, N. Y. (K) 182.
- Searing, M. Munson, Vineland, N. J. (S) 159.
- Seattle Woolen Mills, Kirkland, Wash. (W) 278.
- Sebasticook Woolen Mills (Linn Woolen Co.) 103.
- Sebec Woolen Mills, Sebec, Me. (W) 106.
- Sockel, M. & Co., New York, N. Y. (S) 177.
- Sockinger, L. & Son, Philadelphia, Pa. (W) 226.
- Socky, Frank, Bridgeton, N. J. (W) 148.
- Soffarlan, Joseph A. & Co., Philadelphia, Pa. (W) 226.
- Segregansett Knitting Mill, Taunton, Mass. (K) 131.
- Siedman, David & Sons Mfg. Co., Philadelphia, Pa. (S) 226.
- Siefert, Ernst, Brooklyn, N. Y. (K) 165.
- Simple, Chas. (Louisville Girth & Blanket Mills) 101.
- Seneca Cotton Mills, Seneca, S. C. (C) 267.
- Seneca Woolen Mills, Seneca Falls, N. Y. (W) 180.
- Settle, T. J., Scottsville, Ky. (W) 101.
- Sewall & Day Cordage Co., Boston, Mass. (J) 112.
- Seymour Woolen Factory Co., Seymour, Ind. (W) 98.
- Shack, Geo. W., Vinton, O. (W) 200.
- Shackamaxon Worsted Co. (J. R. Keim & Co.) 219.
- Shackelford, John F. (Riverview Knitting Mills) 195.
- Shady Lea Mill (Rodman Mfg. Co.) 251.
- Shaen, R. H. (Brookside Worsted Mills) 207.
- Shaffer, J. (London Knitting Mills) 165.
- Shaker Knitting Co., East Canterbury, N. H. (K) 143.
- Shamokin Silk Mills, Shamokin, Pa. (S) 247.
- Shamokin Silk Throwing Co., Shamokin, Pa. (S) 247.
- Shamokin Underwear Mills, Shamokin, Pa. (K) 247.
- Shamokin Valley Ktg. Mills, Shamokin, Pa. (K) 247.
- Shamrock Mill (J. W. Hanes) 196.
- Shannock Narrow Fabric Co., Shannock, R. I. (C) 259.
- Shannon, James B., Norwich, Conn. (K) 78.
- Shantz, H. C., Reading, Pa. (K) 245.
- Shardin, Daniel, Schuylkill Haven, Pa. (K) 246.
- Sharidan, J. A. (Orwigsburg Knitting Mills) 243.
- Sharkey, Wm. M., Philadelphia, Pa. (W) 226.
- Sharp, J. B. (New York Textile Co.) 176.
- Sharp & Smith, Chicago, Ill. (K) 95.
- Shaughnessy, James W., Yonkers, N. Y. (S) 184.
- Shaw, Herbert E. (Berkeley Woolen Mills) 132.
- Shaw, H. M., Oxford, N. C. (K). See too Late Classification List.)
- Shaw, James G. (Triton Mills) 84.
- Shaw, Joseph, Philadelphia, Pa. (W) 226.
- Shaw, L. L. & Co. (Royal River Mfg. Co.) 107.
- Shaw Mills, Wales, Mass. (W) 132.
- Shaw Stocking Co., Lowell, Mass. (K) 123.
- Shaw & Bowen, Philadelphia, Pa. (W) 226.
- Shawnee Knitting Mills, Plymouth, Pa. (K) 244.
- Sheafer, W. H., Wisconsin, Pa. (K) 250.
- Sheard Co., Titus, Little Falls, N. Y. (K) 171.
- Sheble, Frank J., Philadelphia, Pa. (W) 226.
- Sheboygan Knitting Co., Sheboygan, Wis. (K) 282.
- Sheehan, D. H., Cold Spring, Mass. (W) 114.
- Sheehan, Dan J., Co., Paterson, N. J. (D) 153.
- Sheehan, T. J. (North Gray Woolen Mill) 105.
- Shefer, Rossa, West Park, N. Y. (C & W) 184.
- Shefner & Olswang, Chicago, Ill. (K) 95.
- Shelby Cotton Mills, Shelby, N. C. (C) 195.
- Sheline, E. R., Edon, Ohio (W) 199.
- Shelmire & Brownhill, Philadelphia, Pa. (K) 226.
- Shephard, John J., Cherry Valley, Mass. (W) 114.
- Sheppard, John P., Salem, N. J. (K) 159.
- Sheridan, Hugh, Ashuelot, N. H. (W) 143.
- Sheridan Woolen Mills (Hugh Sheridan) 143.
- Sherk, John N., Myerstown, Pa. (K) 242.
- Sherlock, J. E. (Home Knitting Works) 273.
- Sherman Carpet Mills (Henry Holmes & Sons) 218.
- Sherman Cotton Mill, Sherman, Tex. (C) 272.
- Shetucket Co., Norwich, Conn. (C) 78.
- Shetucket Wst. Mill, Baltic, Conn. (W) 72.
- Shickshinny Wstd. Mills, Shickshinny, Pa. (W) 247.
- Shields, E. (Shields Knitting Mill) 195.
- Shields Knitting Mill, Scotland Neck, N. C. (K) 195.
- Shimer, Geo. & Son, Camden, N. J. (W) 149.
- Shippee, H. A., Centerville, R. I. (K) 253.
- Shippensburg Knitting Co., Shippensburg, Pa. (K) 247.
- Shirland Knitting Mills (Thos. Greaves) 216.
- Shoal Creek Mfg. Co., Shoal Creek, Ga. (C) 91.
- Shore, J. & Sons (Dresden Woolen Mills) 199.
- Short, W. F., Philadelphia, Pa. (K) 226.
- Shove Mills, Fall River, Mass. (C) 118.
- Shrewsbury Mills, Newark, N. J. (F) 152.
- Shuford, A. A., Hickory, N. C. (K) 190.
- Shuford Mfg. Co., Hickory, N. C. (C) 190.
- Shuler & Benninghofen (Miami Woolen Mills) 199.
- Shurs Lane Mills (T. Kentworthy & Bro.) 219.
- Shutt, George, Little Falls, N. J. (D & F) 152.
- Shuttleworth Bros., Amsterdam, N. Y. (W) 163.
- Shuttleworth, H. L., Amsterdam, N. Y. (W & D) 163.
- Sibley, Geo. F., North Montpelier, Vt. (W) 275.
- Sibley Mfg. Co., The, Augusta, Ga. (C) 86.
- Sibley, Wm., No. Windham, Conn. (W) 73.
- Sibson & Stern, Philadelphia, Pa. (K) 226.
- Sicor, Henry, Philadelphia, Pa. (W) 226.
- Sidbotham, John E., Philadelphia, Pa. (C) 226.
- Sidney Cotton Mills, Graham, N. C. (C) 189.
- Siogel, N. (Williamsburg Knitting Mills) 165.
- Silurian Mills, Newton Lower Falls, Mass. (W) 127.
- Silver Lake Co., Newton, Mass. (C) 127.
- Silver Spring Bleaching & Dyeing Co., Providence, R. I. (Bl, D, Pr & F) 258.

- Silver Spring Mill (Rodman Mfg. Co.) 251.  
 Silver Star Dye Works (Chas. H. Fleming) 215.  
 Simlster, Chas. R., Philadelphia, Pa. (W) 226.  
 Simmons Braid Co., Providence, R. I. (S, W & C) 258.  
 Simmous Knitting Co., Grand Rapids, Mich. (K) 188.  
 Simon, Ernest B., New York, N. Y. (C) 177.  
 Simon, R. & H., Weehauken, N. J. and Easton, Pa. (S) 159, 237.  
 Simons & Struve Hosiery Co., Philadelphia, Pa. (K) 226.  
 Simplex Electrical Co., Boston, Mass. (C) 113.  
 Simpson Bros., Philadelphia, Pa. (C, W & S) 226.  
 Simpson, James & Co., Paterson, N. J., New Hope and Scranton, Pa. (S) 158, 242, 247.  
 Simon & Kirkaldy, Woonsocket, R. I. (W) 261.  
 Single, S., Little Falls, N. J. (W) 152.  
 Singleton, George, Dover, Port Oram, N. J. and Walcesboro, N. C. (S) 149, 158, 196.  
 Singleton Worsted Co., Franklin, Mass. (W) 119.  
 Skenandoa Cotton Co., Utica, N. Y. (C) 182.  
 Skerry, A. T. & Co., Changewater, N. J. (W) 149.  
 Skinner, Wm. Mfg. Co., Holyoke, Mass. (S) 121.  
 Skinner & Kades, Reading, Pa. (K) 245.  
 Slack, John, No. Salem, N. H. (C) 146.  
 Slack, W. H. H. & Bro., Springfield, Vt. (W) 275.  
 Slade Mills, Fall River, Mass. (C) 118.  
 Slater Cotton Co., Pawtucket, R. I. (C) 257.  
 Slater, H. N. Cambrie Works, Est. of, East Webster and Webster, Mass. (C) 115, 133.  
 Slater, Robert, Pompton, N. J. (W) 158.  
 Slater, W. A. Mills, Jewett City, Conn. (C) 76.  
 Slater Woolen Co., Webster, Mass. (W) 133.  
 Slatersville Finishing Co., Slatersville, R. I. (D, B) & F) 259.  
 Slatington Knitting Co., Ltd., Slatington, Pa. (K) 247.  
 Slatington Textile Mfg. Co., Slatington, Pa. (S) 247.  
 Slayden-Kirksey Woolen Mill, Waco, Texas (W) 272.  
 Slear Bros., Sunbury, Pa. (K) 248.  
 Sloane, C. F. (Brighton Mills) 205.  
 Sloane's, James, Sons, New York, N. Y. (W) 177.  
 Small Bros., Fall River, Mass. (C) 118.  
 Smalley, Harry R., Philadelphia, Pa. (K) 226.  
 Smiley, David & Co., Mansfield, Mass. (Pr) 124.  
 Smith, A. H. (Blackstone Stocking Co.) 255.  
 Smith, Alexander & Sons Carpet Co., Yonkers, N. Y. (W) 184.  
 Smith, Amsden H., Co., Pawtucket, R. I. (D) 257.  
 Smith, Channing (Valley Woolen Mill) 114.  
 Smith, C. J., Reading, Pa. (W) 245.  
 Smith, Cowles & Smith (Denver Woolen Mills) 141.  
 Smith, D. B. & Son, Pine Meadow, Conn. (C) 78.  
 Smith, D. W., Newport, N. Y. (K) 173.  
 Smith, Edwin L., Westfield, Mass. (C) 133.  
 Smith, E. L., Gurleyville, Conn. (S) 75.  
 Smith, Frank C. (Tatnuck Woolen Mill) 134.  
 Smith, Fred R., Killingly, Conn. (W) 76.  
 Smith, Fred S., Wilkinstonville, Mass. (W) 134.  
 Smith, Isaac W., Bridgeport, Pa. (W) 234.  
 Smith, J. E. Cotton Mfg. Co., Thomson, Ga. (C) 91.  
 Smith, Jno., Philadelphia, Pa. (W) 226.  
 Smith, Jos. T., Philadelphia, Pa. (W) 226.  
 Smith, Joseph, Philadelphia, Pa. (C) 226.  
 Smith, Oscar & Son, Philadelphia, Pa. (C) 226.  
 Smith, Robert M., Lawrence, Mass. (C) 122.  
 Smith, S. K. (Becket Silk Co.) 111.  
 Smith, Thomas, Philadelphia, Pa. (D) 226.  
 Smith, Thos. H. (Lamestown Cotton Mills) 171.  
 Smith Webbing Co., Pawtucket, R. I. (C) 257.  
 Smith, W. T. & Son, Philadelphia, Pa. (W & C) 226.  
 Smith & Beck, Schuylkill Haven, Pa. (K) 246.  
 Smith & Bever, New York, N. Y. (D & F) 177.  
 Smith & Choppin, New York, N. Y. (F) 177.  
 Smith and Cooley, Stafford Springs, Conn. (W) 80.  
 Smith & Dove Mfg. Co., Andover, Mass. (Fl) 111.  
 Smith & Kauffman, New York, N. Y. (S) 177.  
 Smith & Ross, Birdsboro, Pa. (K) 233.  
 Smitherman Cotton Mills, Troy, N. C. (C) 196.  
 Smithfield Cotton Mills, Smithfield, N. C. (C) 195.  
 Smyrna Rug Mfg. Co. (Mohawk Mills) 161.  
 Smyrna Shirt and Hosiery Co., Smyrna, Del. (K) 84.  
 Smythe Mfg. Co. (Belton Mills) 262.  
 Snow, J., Hardware Co., Tuscaloosa, Ala. (C) 70.  
 Social Circle Cotton Mills, Social Circle, Ga. (C) 91.  
 Solway Mills, Westerly, R. I. (C) 260.  
 Somerset Carpet Mill (Estate of M. J. Galbraith) 215.  
 Somerset Knitting Co., Hyde Park, Mass. (K) 121.  
 Somerset Mfg. Co., Raritan, N. J. (W) 159.  
 Somerset & Co., Philadelphia, Pa. (W) 226.  
 Somersville Mfg. Co., Somersville, Conn. (W) 80.  
 Somerville Woolen Mills, The, Somerville, N. J. (W) 159.  
 Soo Woolen Mill, Sault Ste Marie, Mich. (W) 139.  
 Souder, John T., Myerstown, Pa. (W) 242.  
 Soule Mills Corp., New Bedford, Mass. (C) 126.  
 Souls', William Sons (Rockstone Mills) 237.  
 So. Acton Woolen Co., South Acton, Mass. (W) 130.  
 South Bend Woolen Co., South Bend, Ind. (W) 98.  
 South Side Knitting Mills (Rowe & Best) 161.  
 South Side Mfg. Co., Winston, Salem, N. C. (C) 197.  
 South Union Mills (Ledbetter Mfg. Co.) 194.  
 Southbridge Printing Co., Southbridge, Mass. (Pr & P) 130.  
 Southdown Knitting Co., Allentown, Pa. (K) 231.  
 Southern Bedding & Mfg. Co., Austin, Texas (C) 271.  
 Southern Cotton Mills, Bessemer City, N. C. (C) 184.  
 Southern Hosiery Mills, Newburn, N. C. (K) 193.  
 Southern Shoddy Mills, Rossville, Ga. (W) 91.  
 Southern Waste Works, Ltd., Philadelphia, Pa. (C & W) 226.  
 Southern Woolen Mills, Kernersville, N. C. (W) 191.  
 Southgate Woolen Co., Worcester, Mass. (W) 134.  
 Southwark Mills Co., The, Phila., Pa. (W) 227.  
 Spalngthorpe, Isaac (Estate of) Philadelphia, Pa. (K) 227.  
 Spalding Cotton Mills, The, Griffin, Ga. (C) 89.  
 Spangler & Turrow, Raleigh, W. Va. (W) 279.  
 Sparta Cotton Mills, Sparta, Ga. (C) 91.  
 Spartan Mills, Spartanburg, S. C. (C) 267.  
 Spatz, J. H. & Co., Mohr's Store, Pa. (W) 211.  
 Special Knitting Works, Detroit, Mich. (K) 137.  
 Specialty Weaving Co., Shelton, Conn. (S) 79.  
 Speedwell Knitting Mill (Harry Y. Yocom) 238.  
 Spencer Mountain Mills, Lowell, N. C. (C) 192.  
 Spencer, W. H. (Henry Carpet Shop) 95.  
 Spencer & Chatterton, Philadelphia, Pa. (C) 227.  
 Sperling's, E. M. Sons, New York, N. Y. (S) 177.  
 Sperry & Beale, Brooklyn, N. Y. (C) 165.  
 Spicer Bros., Brooklyn, N. Y. (K) 165.  
 Spicket Falls Bleach & Dye Works, Methuen, Mass. (Bl & D) 125.  
 Spier, S., Brooklyn, N. Y. (K) 165.  
 Spiering, Adolph, Appleton, Wis. (W & D) 280.  
 Spindler, E. O., Shamokin, Pa. (K) 247.  
 Spink, William, Philadelphia, Pa. (W & D) 227.  
 Sponhauer, A., Oakland Mills, Pa. (W) 243.  
 Spray Cotton Mills, Spray, N. C. (C) 195.  
 Spring City Hosiery Mills (W. C. Urner & Co.) 248.  
 Spring Garden Underwear Mill (H. Berger & Sons) 246.  
 Spring Lake Mfg. Co., Washington, R. I. (W) 260.  
 Spring Silk Co., Paterson, N. J. (S) 158.  
 Spring Valley Flax Fibre Co., Spring Valley, Minn. (Fl) 140.  
 Springfield Blanket Co., Holyoke, Mass. (W) 121.  
 Springfield Braid Co., Springfield, Mass. (S & W) 131.  
 Springfield Cotton Mill, Laurel Hill, N. C. (C) 191.

- Springfield, C. W., Alfred, Me. (W) 102.  
 Springfield Felting Co., Springfield, Mass. (W) 131.  
 Springfield Knitting Co., Springfield, Mass. (K) 131.  
 Springfield Waste Co., Springfield, Mass. (C) 131.  
 Springfield Webbing Co., Springfield, Mass. (C) 131.  
 Springfield Woolen Mills, Springfield, Ill. (W) 96.  
 Springfield Worsteds Mills, Bordentown, N. J. (W) 148.  
 Springstein Mills, The, Chester, S. C. (C) 263.  
 Springville Mfg. Co., Rockville, Conn. (W) 79.  
 Sprowles, J. H. Co., The, Philadelphia, Pa. (K) 227.  
 Sprucedale Mill (A. Williams & Co.) 80.  
 Squam Lake Mill (Robt. H. Hart) 143.  
 Stafford, J. P., Est. of, Brasher Falls, N. Y. (W) 163.  
 Stafford Mfg. Co., Central Falls, R. I. (C) 253.  
 Stafford Mills, Fall River, Mass. (C) 118.  
 Stafford Worsteds Co., Stafford Springs, Conn. (W) 50.  
 Stafford & Clark, West Stockholm, N. Y. (W) 184.  
 Stafford & Co., Philadelphia, Pa. (W) 227.  
 Stafford's Sons, Jas., Philadelphia, Pa. (W) 227.  
 Staffordville Woolen Co., Staffordville, Conn. (W) 80.  
 Stager, H. L., Mount Joy, Pa. (W) 242.  
 Staley, A. C., Mfg. Co., South Bend, Ill. (K) 98.  
 Stamford Knitting Mill (John R. Kirkham) 75.  
 Stamford Worsteds Mills, Stamford, Conn. (See too Late Classification List.)  
 Standard Bleachery Co., Carlton Hill, N. J. (Bl. D & F) 149.  
 Standard Cotton Mills, Cedartown, Ga. (C) 86.  
 Standard Fast Black Dye Works, Phila., Pa. (D) 227.  
 Standard Hicks Hammock Co., Mount Holly, N. J. (C) 152.  
 Standard Hosiery Co., Philadelphia, Pa. (K) 227.  
 Standard Knitting Mill (Albert H. Kline) 246.  
 Standard Knitting Mills, Philadelphia, Pa. (K) 227.  
 Standard Ktg. Mill, Brooklyn, N. Y. (K) 165.  
 Standard Knitting Mills, Knoxville, Tenn. (K) 270.  
 Standard Ktg. Mills Co., Brooklyn, N. Y. (K) 165.  
 Standard Mantle Knitting Co., Chicago, Ill. (K) 95. (Also See too Late Classification List.)  
 Standard Mfg. Co., Athens, Ga. (K) 55.  
 Standard Mill (Parsons Mfg. Co.) 167.  
 Standard Mills (Greaves Bros.) 216.  
 Standard Mills (Robt. Megowan) 222.  
 Standard Rope and Twine Co., Bath, Me. (D) 102.  
 Standard Silk Co., Phillipsburg, N. J. (S) 158.  
 Standard Spinning Co., Chester, Pa. (C) 235.  
 Standard Thread Co., New York, N. Y. (C) 177.  
 Standard Woolen Co., Rutland, Mass. (C) 139.  
 Standard Worsteds Mills (Jas. Doak, Jr. & Co.) 213.  
 Standard Yarn Co., Oswego, N. Y. (C) 179.  
 Standish Worsteds Co., Plymouth, Mass. (W) 129.  
 Standring, James, Newburgh, N. Y. (W) 173.  
 Stanley Creek Cotton Mills, Stanley, N. C. (C) 195.  
 Stansfield, Geo. (Consolidated Woolen Felt Mill) 161.  
 Stanton, J. E., Schuylkill Haven, Pa. (K) 246.  
 Star Braid Works (S. B. & B. W. Fleisher) 215.  
 Star Carpet Mill (Joseph Taylor & Son) 228.  
 Star Hosiery Mills, Hazaman's Mills, N. Y. (K) 169.  
 Star Knitting Co., La Crosse, Wis. (K) 281.  
 Star Knitting Co., Cohoes, N. Y. (K) 167.  
 Star Knitting Mill (Baker Bros.) 246.  
 Star Knitting Mills, Norristown, Pa. (K) 243.  
 Star Knitting Mills, Delanco, N. J. (K) 149.  
 Star Knitting Works, Grand Rapids, Mich. (K) 138.  
 Star Ribbon Mfg. Co., New York, N. Y. (S) 177.  
 Star Seamless Hosiery Mill (W. G. Ellis & Co.) 213.  
 Star Silk Co., Paterson, N. J. (S) 158.  
 Star State Mill, Huntsville, Texas (W) 272.  
 Star Thread Mills, Athens, Ga. (C) 85.  
 Star Woolen Mills (Jas. Stafford's Sons) 227.  
 Star Worsteds Co., Fitchburg, Mass. (W) 119.  
 Star & Crescent Mills Co., Philadelphia, Pa. (C) 227.  
 Starin Silk Fabric Co., Fultonville, N. Y. (K) 169.  
 Stark Mills, Manchester, N. H. (C) 146.  
 Starr, Hyman, New York, N. Y. (K) 177.  
 Starr Knitting Works (Hyman Starr) 177.  
 Star Net and Twine Co., East Hampton, Conn. (C) 75.  
 Starr, W. E., Newton Falls, O. (W) 200.  
 Starrels, M., Philadelphia, Pa. (K) 227.  
 State Jute Mill, Walla Walla, Wash. (J) 278.  
 State Penitentiary, Bismark, N. D. (C) 197.  
 State Penitentiary, Lansing, Kan. (Fl & J) 100.  
 State Penitentiary, Sing Sing, N. Y. (K) 181.  
 State Penitentiary (Star State Mill) 272.  
 State Penitentiary (State Jute Mill) 272.  
 State Prison, Auburn, N. Y. (W & L) 163.  
 State Prison (San Quentin Jute Factory) 72.  
 State Prison, Stillwater, Minn. (FD) 140.  
 State Silk Plant, Peabody, Kan. (S) 100.  
 Statesville Cotton Mills, The, Statesville, N. C. (C) 195.  
 Stayton Carding & Spinning Mill, Stayton, Ore. (W & K) 201.  
 Stead, Miller & Co., Philadelphia, Pa. (S & D) 227.  
 Steam Knitting Mill (H. A. Shippee) 253.  
 Stearns, John N. & Co., Elmira, N. Y., Williamsport, Pa. and Petersburg, Va. (S) 168, 250, 278.  
 Stearns & Foster Co., Cincinnati, Ohio (C) 198.  
 Stegman, H., Forks of Elkhorn, Ky. (W) 100.  
 Steel, Edward T. & Co., Bristol, Pa. (W) 234.  
 Steele & Laney, Philadelphia, Pa. (C) 227.  
 Steele's Mills, Rockingham, N. C. (C) 194.  
 Steelton Hosiery Factory, Steelton, Pa. (K) 248.  
 Steere Worsteds Mills, Providence, R. I. (W) 258.  
 Stehli & Co., Lancaster, Pa. (S) 239.  
 Stein, Samuel P., Newark, N. J. (K) 153.  
 Steinberg & Rawitzer, New York, N. Y. (S) 177.  
 Steinhart, C., New York, N. Y. (S) 177.  
 Steintal, L. & Bro., New York, N. Y. (K) 177.  
 Stephens & Beetem, Carlisle, Pa. (W) 234.  
 Stephenson Bros. (Oslo Wm. Mill) 282.  
 Sterling Carpet Mills, Philadelphia, Pa. (W) 227.  
 Sterling Cotton Mills, Franklinton, N. C. (C) 188.  
 Sterling Dyeing & Finishing Co., Sterling, Conn. (D & F) 80.  
 Sterling Knit Goods Co., Boston, Mass. (K) 113.  
 Sterling Mills, Hion, N. Y. (K) 170.  
 Sterling Mills Co., Bridgeport, Pa. (W) 231.  
 Sterling Worsteds Co., Clinton, Mass. (W) 114.  
 Stern, Pohley & Herman, Paterson, N. J. (S) 158.  
 Stetson Co., Jno. B., Philadelphia, Pa. (W) 227.  
 Steuben Silk Co., Hornellsville, N. Y. (S) 170.  
 Stevens, Chas. A. & Co., Ware, Mass. (W) 133.  
 Stevens, Eben S., Quinebaug, Conn. and Webster, Mass. (W) 79, 123.  
 Stevens, F. K., Chicago, Ill. (W & K) 95.  
 Stevens Linen Wks., Webster, Mass. (FD) 133.  
 Stevens Mfg. Co., Fall River, Mass. (C) 118.  
 Stevens Mills, No. Andover, Mass. (W) 127.  
 Stevens, M. T. & Sons Co., No. Andover, Mass. (W) 127.  
 Stevens & Co., Haverhill, Mass. (W) 120.  
 Stevenson, Joseph, Nescopeck, Pa. (W) 242.  
 Stewart, John K., Amsterdam, N. Y. (K) 163.  
 Stewart Knitting Mill, Newport News, Va. (K) 277.  
 Stewart, Reverdy (Stewart Knitting Mill) 277.  
 Stewart, V. & B., Guyandotte, W. Va. (W & K) 273.  
 Stewart, W. & Co. (Essex Dye Wks.) 122.  
 Stickler, John M. (Mauston Wm. Mills) 281.  
 Stickler, L. H. (Galesville Woolen Mills) 281.  
 Stief, H. M. & Son, Philadelphia, Pa. (C) 227.  
 Stifel, J. L. & Sons, Wheeling, W. Va. (Pr) 250.  
 Stiffson, Samuel J., New York, N. Y. (S) 177.  
 Stiles Knitting Co., E. W., The, Woonsocket, R. I. (K) 261.

- Stilller, Paul, Jersey City, N. J. (C) 151.  
 Stimpson & Steele, Turnersburg, N. C. (C) 196.  
 Stinson Bros., Philadelphia, Pa. (W) 227.  
 Stirk, John, Sherman, Pa. (W) 247.  
 Stirling Mills, Lowell, Mass. (W) 124.  
 Stirling Silk Mfg. Co., Stirling, N. J. (S) 159.  
 Stirling Woolen Mills Co., Farmington, Iowa (W) 99.  
 Stockton Bros., Philadelphia, Pa. (K) 227.  
 Stockton Rug & Carpet Manufactory, Stockton, Cal. (W & S) 72.  
 Stockton Woolen Mill, Stockton, Ill. (W) 96.  
 Stockton Woolen Mills, The, Stockton, Cal. (W) 72.  
 Stohn, C., Boston, Mass. (W & S) 113.  
 Stohne & Mincke, Jersey City, N. J. (S) 152.  
 Stohn's, C., Sons, Jersey City, N. J. (S) 152.  
 Stone Cotton Mills, John M., Starkville, Miss. (C) 141.  
 Stone Worsted Mills, Pascoag, R. I. (W) 255.  
 Stoneman, G. T., Albany, N. Y. (K) 161.  
 Stonewall Cotton Mills, Stonewall, Miss. (C) 141.  
 Stony Creek Mills (Louis Kraemer & Co.) 245.  
 Stork Knitting Mills, The, Reading, Pa. (K) 246.  
 Storms, A. L. & Co., Weissport, Pa. (S) 249.  
 Stott, A. J., McDonough, N. Y. (W & K) 172.  
 Stott Woolen Co., Stottville, N. Y. (W) 181.  
 Stoughton Mills, West Stoughton, Mass. (W) 133.  
 Strange, Wm., Co., The, Paterson, N. J. (S) 158.  
 Stratford Knitting Mills, Phila., Pa. (K) 227.  
 Straus, F. A. & Co., Paterson, Trenton, N. J. and Chester, Pa. (S & W) 158, 159, 235.  
 Strauss-Cahn Knitting Co., Chicago, Ill. (K) 95.  
 Street, Mrs. M. J., Bluff Spring, Ala. (W) 67.  
 Stretton, Chas. Sons, Stoughton, Mass. (K) 131.  
 Strickland Cotton Mills, Valdosta, Ga. (C) 92.  
 Strong, Hewat & Co., North Adams, Mass. (W) 127.  
 Stroock Felt Co., Newburgh, N. Y. (W) 173.  
 Stroud, David H., Philadelphia, Pa. (W) 227.  
 Stuart, W. & Co. (Essex Dye Works) 122.  
 Stuerman, Abram, Jersey City, N. J. (D & F) 152.  
 Stumpf & Schwartz, New York, N. Y. (D) 177.  
 Sturzenegger, Edm., New York, N. Y. (S) 177.  
 Styer Lace and Drapery Co., Chicago, Ill. (S) 95.  
 Success Worsted Co., North Chelmsford, Mass. (W) 128.  
 Suffolk Dye Works, Suffolk, Va. (D) 278.  
 Suffolk Knitting Mills, Suffolk, Va. (K) 278.  
 Sugar River Mill (Dexter Richards & Sons) 146.  
 Sugden Press Bagging Co., West Chelmsford, Mass. (W) 133.  
 Sullivan, J. & Sons Mfg. Co., Philadelphia, Pa. (C) 227.  
 Sullivan, R. T., Co., Newton Lower Falls, Mass. (W) 127.  
 Sullivan, William & Co., Philadelphia, Pa. (W & K) 227.  
 Sullivan Woolen Mills (S. Brunger & Co.) 98.  
 Sullivan & Webster (Walkone Dye & Finishing Works) 228.  
 Sulloway Mills, Franklin Falls, N. H. (K) 145.  
 Sultan Textile Mills, Philadelphia, Pa. (C) 227.  
 Summerville Dyeing, Printing & Finishing Works, Philadelphia, Pa. (D, Pr & B) 227.  
 Summit Silk Company, New York, N. Y. 177.  
 Summit Silk Mfg. Co., Summit, N. J. (S) 159.  
 Summit Thread Co., East Hampton, Conn. (C) 75.  
 Summit Woolen Co., Staffordville, Conn. (W) 80.  
 Summerville, A. C. (Magnolia Mills) 185.  
 Sumner, Fairbanks & Co. (East Blackstone Yarn Co.) 111.  
 Sumner, Thos. & Son, Philadelphia, Pa. (C) 227.  
 Sumner, Wm., Belting Co., Tolland, Conn. (C) 81.  
 Sumter Cotton Mills, Sumter, S. C. (C) 267.  
 Sun Mills Mfg. Co., Fitchburg, Mass. (C) 119.  
 Sun Narrow Fabric Co., The, Wilkesbarre, Pa. (C) 250.  
 Sunbury Hosiery Mills (Slear Bros.) 248.  
 Sunbury Worsted Spinning Co., Sunbury, Pa. (W) 248.  
 Sundheimer Bros., New York, N. Y. (S) 177.  
 Sunnyside Mills (E. V. Pike) 235.  
 Superior Knitting Mills Co., Elmira, N. Y. (K) 168.  
 Superior Underwear Co., Bowling Green, Ohio (K) 197.  
 Sussex Mills, Sussex, N. J. (C) 159.  
 Susquehanna Dye Works, Williamsport, Pa. (D) 250.  
 Susquehanna Silk Mills, Marlon, O. and Sunbury, Pa. (S) 199, 248.  
 Susquehanna Woolen Co., New Cumberland, Pa. (W) 242.  
 Sutcliffe Bros., Marlboro, N. Y. (W) 172.  
 Sutherland Mfg. Co., Augusta, Ga. (C) 86.  
 Sutherland & Edwards Co., Paterson, N. J. (J) 158.  
 Sutor Bros. Braid Co., New York, N. Y. (S) 177.  
 Sutro, E. & Son, Philadelphia, Pa. (K & D) 227.  
 Sutton Mills, No. Andover Depot, Mass. (W) 127.  
 Swain Mfg. Co., Methuen, Mass. (K) 125.  
 Swan, W. H., Estate of, Mendon, Mass. (W) 124.  
 Swansea Dye Works, Fall River, Mass. (D & Pr) 118.  
 Swartz, B. F., Reading, Pa. (K) 246.  
 Swartz, C. (Lehigh Knitting Mills) 231.  
 Sweeney, W. W. Co., Los Angeles, Cal. (K) 71.  
 Sweetgrass Woolen Mill, Big Timber, Mont. (W) 142.  
 Sweetwater Woolen Mills, Sweetwater, Tenn. (W) 271.  
 Swenson, Harold, New London, Minn. (W) 140.  
 Swift, John & Co., Paterson, N. J. (S) 158.  
 Swift Mfg. Co., Columbus, Ga. (C) 88.  
 Swift River Co., Smith's, Mass. (W) 130.  
 Swift's Cotton Mill, Elberton, Ga. (C) 88.  
 Swire & Scott, Philadelphia, Pa. (W) 228.  
 Swiss Knitting Co., Dover, N. J. (K) 149.  
 Sycamore Mills, Sycamore, Ala. (C) 70.  
 Sykes, A. & Co., Mount Holly, N. J. (W) 152.  
 Sykes Bros., Philadelphia, Pa. (W) 228.  
 Sykes, D., Philadelphia, Pa. (W) 228.  
 Sykes, G. W. & Son, Reynoldsville, Pa. (W) 246.  
 Sylvan Cotton Mills, Shelbyville, Tenn. (C) 271.  
 Syracuse Silk Co., Syracuse, N. Y. (S) 181.  
 Tabor Rock Mill, East Lyme, Conn. (C) 75.  
 Taconic Mills, Pittsfield, Mass. (W) 129.  
 Tacony & Fairmount Worsted Mills (Erben, Harding & Co.) 213.  
 Taft, A. L., Spencer, Mass. (W) 131.  
 Taft, Arthur L. (Union Woolen Mills) 147.  
 Taft, Burbank & Murdock (Proctorsville Mills) 275.  
 Taft, David N., No. Oxford and Oxford, Mass. (W) 128.  
 Taft, Murdock & Co., Careyville, Mass. (W) 113.  
 Talbot Mills, North Billerica, Mass. (W) 128.  
 Talcott Bros., Talcottville, Conn. (W) 81.  
 Talladega Cotton Factory, Talladega, Ala. (C) 70.  
 Talladega Hosiery Mills, Talladega, Ala. (K) 70.  
 Tallapoosa Cotton Mill Co., Tallapoosa, Ga. (C) 91.  
 Tallasse Falls Mfg. Co., Montgomery and Tallahsee, Ala. (C) 69, 70.  
 Tarboro Cotton Factory, Tarboro, N. C. (C) 195.  
 Tariffville Lace Mfg. Co., The, Tariffville, Conn. (C) 81.  
 Tate & Co., Malden, Mass. (C) 124.  
 Tate & Stovall, Carleton, Ga. (C) 86.  
 Tatnuck Woolen Mill, Worcester, Mass. (W) 134.  
 Taubel, Lewis E. (Star Knitting Mills) 243.  
 Taubel, Wm. F., Riverside, N. J., and Shamokin, Pa. (K) 159, 247.  
 Tauber Woolen Mills, The, Spartansburg, Pa. (W & K) 248.  
 Taunton Dye Works & Bleachery Co., Taunton, Mass. (Bl & D) 131.  
 Tavona Mills, Yorkville, S. C. (C) 268.  
 Taylor, Bramley Co., The, Chicopee Falls, Mass. (K) 111.  
 Taylor Bros., Philadelphia, Pa. (W) 228.  
 Taylor Co., Chas., Wilmington, Del. (K & D) 84.  
 Taylor, H. C. Bohne, Mrs. (Garden City Knitting Works) 95.  
 Taylor, Herbert G., Philadelphia, Pa. (Bl & F) 228.  
 Taylor, James, Paterson, N. J. (S) 158.  
 Taylor, Joseph, Paterson, N. J. (S) 158.  
 Taylor, Joseph & Son, Philadelphia, Pa. (W) 228.



- Taylor Mfg. Co., Potteryville, Ga. (C) 91.  
 Taylor Mfg. Co., Hope Valley, R. I. (W) 254.  
 Taylor, Noone & Co., Philadelphia, Pa. (W) 228.  
 Taylor Rug Co., Minneapolis, Minn. (W) 140.  
 Taylor Silk Mfg. Co., Paterson, N. J., and Dickson, Pa. (S) 158, 236.  
 Taylor, Simon, Spencer, Mass. (W) (See Too Late Classification List)  
 Taylor, Thos. & Son, Hudson, Mass. (C) 121.  
 Taylor Worsted Co., Taylor, Pa. (S) 248.  
 Taylor & Hubbard (Springfield Braid Co.) 131.  
 Taylor & Scott, Philadelphia, Pa. (C) 228.  
 Taylor's Falls Woolen Mills, Taylor's Falls, Minn. (W) 140.  
 Teather, Sam'l, Brooklyn, N. Y. (K) 165.  
 Tecumseh Facing Mills, Michigan City, Ind. (K) 97.  
 Tecumseh Mills, Fall River, Mass. (C) 118.  
 Tell City Woolen Mills, Tell City, Ind. (W) 98.  
 Templeton Bros. (Shawnee Knitting Mills) 244.  
 Templeton Mills, Otter River, Mass. (W) 128.  
 Tennessee Cotton Mills Co., Elizabethton, Tenn. (C) 269.  
 Tennessee Line & Twine Co., Elizabethton, Tenn. (C) 269.  
 Tennessee Mfg. Co., Nashville, Tenn. (C) 270.  
 Tennessee Woolen Mills, McMinnsville, Tenn. (W) 270.  
 Tennille Cotton Mills, Tennille, Ga. (C) 91.  
 Terra Alta Woolen Mills, Terra Alta, W. Va. (W) 280.  
 Teschmacher, Wm., Brooklyn, N. Y. (D) 165.  
 Teuton Hosiery Co., Cincinnati, Ohio (K) 198.  
 Texas Hosiery Mfg. Co., San Antonio, Texas. (K) 272.  
 Textile Mfg. Co., Rockingham, N. C. (C) 194.  
 Textile Novelty Co., Starkville, Miss. (C) 141.  
 Thomas, H. B., Philadelphia, Pa. (W) 228.  
 Thomas Knitting Mills, S., Schuylkill Haven, Pa. (K) 246.  
 Thames Valley Mills (Hall Bros.) 78.  
 Thayer, E. D., Jr., Cherry Valley and Dedham, Mass. (W) 114, 115.  
 Thayer Mfg. Co., L. D., Worcester, Mass. (C & S) 134.  
 Thayer Woolen Co., Killingly, Conn. No. Oxford, and Worcester, Mass. (W) 76, 128, 134.  
 The Dalles Wool Scouring Mills Co., The Dalles, Ore. (W) 201.  
 Thies, Chas. H. & Son, Steelville, Ill. (W) 96.  
 Thistle Mills Co., Hechester, Md. (C & S) 108.  
 Thom, W. B. & Co., Haverhill, Mass. (W) 120.  
 Thomas Cotton Mills, Little Rock, Ark. (C) 71.  
 Thomas, Sheldon, Central Village, Conn. (C) 73.  
 Thomas & Brown, New York, N. Y. (S) 177.  
 Thomaston Cotton Mills, Thomaston, Ga. (C) 91.  
 Thompson, A. J., Laurel Bluff, N. C. (C) 191.  
 Thompson Bros., Turnerville, Conn. (C) 81.  
 Thompson Bros., Lewiston and Milroy, Pa. (K) 240, 241.  
 Thompson, Chas. H., Fort white, Fla. (K) 84.  
 Thompson, Geo. E., Cohoes, N. Y. (C) 167.  
 Thompson, James & Co., Valley Falls, N. Y. (C & F) 183.  
 Thompson, T. C., Leeds, Ala. (C) 69.  
 Thompson & Corbett (New York Knitting Mills) 176.  
 Thorn Run Factory (J. C. Billmyre) 279.  
 Thornbury Worsted Mills (Edward T. Steele & Co.) 234.  
 Thorndike Co., Thorndike and West Warren, Mass. (C) 131, 133.  
 Thorndike Mfg. Co., Lowell, Mass. 124  
 Thornton, Wm., Abingon, Pa. (W) 231.  
 Thornton, Wm., Philadelphia, Pa. (W) 228.  
 Thornton, Uriah, Philadelphia, Pa. (W) 228.  
 Thorpe, J. B., Highlandville, Mass. (K) 120.  
 Thorpe, Richard, Philadelphia, Pa. (C & L) 228.  
 Threapleton, Wm. B., Philadelphia, Pa. (K) 228.  
 Threlfall & Stelle, Paterson, N. J. (S) 158.  
 Thurkauf, Virgil, New York, N. Y. (D) 177.  
 Thurman, Harry W., Philadelphia, Pa. (K) 228.  
 Thurston-Clark Hosiery Co., Saddle River, N. J. (K) 159.  
 Tiedemann, Theo. & Son, New York, N. Y. (D & F) 177.  
 Tiffany Bros., Bennington, Vt. (K) 273.  
 Tiffin Woolen Mills, Tiffin, O. (W) 200.  
 Tifton Cotton Mills Co., Tifton, Ga. (C) 91.  
 Tifton Knitting Mills, Tifton, Ga. (K) 91.  
 Tillinghast, Stiles & Co., Providence, R. I. (C & W) 258.  
 Tillotson Mfg. Co., Pittsfield, Mass. (W) 129.  
 Tilt Silk Mill, Pottsville, Pa. (S) 244.  
 Tilton, G. H., Savannah, Ga. (C), Laconia, Tilton, N. H., and Columbia, S. C. (K) 91, 145, 147, 263.  
 Tilton Mills, Tilton, N. H. (W) 147.  
 Times Finishing Works (Samuel Lea & Son) 220.  
 Timme, E. F. & Son, Paterson, N. J., and Swarthmore, Pa. (S & F) 158, 248.  
 Tingley, Geo. S., Nooseneck Hill, R. I. (C) 255.  
 Tingue Mfg. Co., The, Seymour, Conn. (W) 79.  
 Tinkham, Wm. & Co., Harrisville, R. I. (W) 254.  
 Tioga Mills (Thos. Henry & Sons) 217.  
 Tioga Silk Co., Athens, Pa. (S) 232.  
 Tioga Textile Co., Philadelphia, Pa. (W) 228.  
 Tipton Cotton Mill, Tipton, Tenn. (C) 269.  
 Titherington, Eli & Son, Philadelphia, Pa. (W) 228.  
 Titus Flannel Co., Poughkeepsie, N. Y. (W) 179.  
 Tivoli Mills (Root Mfg. Co.) 167.  
 Toccoa Cotton Mills, The, Toccoa, Ga. (C) 91.  
 Todd, Burgess William, Collegeville, Pa. (K) 236.  
 (See also Perkiomen Knitting Mills, too Late Classification List.)  
 Todd, Geo. W. & Co. (Unicorn Mills) 108.  
 Todd, J. C., Paterson, N. J. (J) 158.  
 Toff, Prosznit & Co., New York, N. Y. (S) 177.  
 Tolar-Hart & Holt Mills, Fayetteville, N. C. (C) 188.  
 Toledo Knitting Co., Toledo, O. (K) 200.  
 Tombigbee Mill, Columbus, Miss. (C) 140.  
 Tonawanda Mill (Wm. Kemmerling) 219.  
 Topeka Woolen Mill Co., Oakland, Kansas (W) 100.  
 Tonham, Chas., Philadelphia, Pa. (C) 228.  
 Topham, Chas. H., Philadelphia, Pa. (W) 228.  
 Topham, F. H., Boston, Mass. (K) 113.  
 Totokett Mills, Norwich, Conn. (C) 78.  
 Totowa Silk Co., Paterson, N. J. (S) 158.  
 Tournier & Lauber, Philadelphia, Pa. (C) 228.  
 Towanda Knitting Mills, Towanda, Pa. (K) 249.  
 Town Creek Woolen Mills, Winchester, Tenn. (W) 271.  
 Townsend, Edward, Philadelphia, Pa. (K) 228.  
 Townsend, E. A. & Co., Philadelphia, Pa. (W & D) 228.  
 Townsend, H. C., Anderson, S. C. (C) 262.  
 Townsend, H. H., Milton Mills, N. H. (W) 146.  
 Townsend, James P., Marlboro, N. H. (W) 146.  
 Tracy, E. A., So. Coventry, Conn. (W) 80.  
 Tracy Worsted Mills Co., The, Philadelphia, Pa. (W) 228.  
 Trainer Spinning Co., Trainer, Pa. (C) 249.  
 Trainer, T. W., Trainer, Pa. (C) 249.  
 Travers Bros. Co., New York, N. Y. (J) 177.  
 Travis Yarn Co., Philadelphia, Pa. (C) 228.  
 Travora Mfg. Co., Graham, N. C. (C) 189.  
 Treat, Robert B. (Centerville Cotton Mill) 253.  
 Tremont Hosiery Mill (J. A. Lutz) 249.  
 Tremont Worsted Co., Methuen, Mass. (W) 125.  
 Tremont & Suffolk Mills, Lowell, Mass. (C) 124.  
 Trenton Cotton Mills, Gastonia, N. C. (C) 189.  
 Trenton Cotton Mills, Trenton, Tenn. (C) 271.  
 Trenton Worsted Mills, Trenton, N. J. (W) 159.  
 Trevorton Silk Mill, Trevorton, Pa. (S) 249.  
 Trimble Cless Hat Co., Orange Valley, N. J. (W) 153.  
 Trio Mfg. Co., Forsyth, Ga. (C) 88.  
 Trion Mfg. Co., Trion Factory, Ga. (C) 91.  
 Triton Mills, New Castle, Del. (C) 84.  
 Troth, Wm. P., Jr. & Co., Philadelphia, Pa. (C) 228.  
 Trott, John C., Co., Braintree, Mass. (C) 113.  
 Troy Blanket Mills, Troy, N. H. (W) 147.  
 Troy Cotton & Woolen Mfg. Co., Fall River, Mass. (C) 115.  
 Troy Knitting Co., Troy, N. Y. (K) 182.  
 Troy Knitting Co., Troy, Pa. (K) 249.

- Troy Waste Mfg. Co., Cohoes, N. Y. (C & W) 167.
- Troyer, Simon D., Beck's Mills, Ohio (W & K) 197.
- Truax, Greene & Co., Chicago, Ill. (K) 95.
- Trump, F. H. & Son, Milford, Mich. (K) 138.
- Tryon Hosiery Co., Lynn, N. C. (K) 192.
- Tubbs Cordage Co., San Francisco, Cal. (J) 72.
- Tucapau Mills Co., Tucapau, S. C. (C) 267.
- Tuckasee Mfg. Co., Mt. Holly, N. C. (C) 193.
- Tucker & Carter Rope Co., New London, N. C. (C) 193.
- Tucker & Cook Mfg. Co., Conway, Mass. (C) 115.
- Tupelo Cotton Mill, Tupelo, Miss. (C) 141.
- Turner, A. G., Colchester and Willimantic, Conn. (S) 73, 83.
- Turner, Daniel, Bay View, Md. (W) 108.
- Turner, P. W. & Co., Turnerville, Conn. (S) 81.
- Turner Woolen Mills (F. T. Faulkner) 107.
- Turner's Falls Cotton Mills, Turner's Falls, Mass. (C) 122.
- Tuscaloosa Mills, Tuscaloosa, Ala. (C) 70.
- Tuscaroro Cotton Mill, Mt. Pleasant, N. C. (C) 192.
- Tuxedo Carpet Mills (Archibald Holmes & Son) 218.
- Tweedy, A. E., Danbury, Conn. (S) 73.
- Twin City Knitting Mills, Winston-Salem, N. C. (K) 197.
- Two Rivers Knitting Mill, Two Rivers, Wis. (K) 282.
- Tyger Cotton Mills, Fairmont, S. C. (C) 263.
- Tynan, Jos. E., Paterson, N. J. (S) 158.
- Ulrick & Knull, Hummelstown, Pa. (K) 239.
- Uncas Knitting Co., Danielson, Conn. (K) 73.
- Uncasville Mfg. Co., Uncasville and Versailles, Conn. (C) 81.
- Underhill, W. K., Bloomfield, N. J. (S) 148.
- Undine Twine Co. (A. E. Purple) 76.
- Unger, M. & Co., New York, N. Y. (S) 177.
- Unger, G. W., Boyertown, Pa. (K) 234.
- Unger, Samuel, Pottsville, Pa. (K) 244.
- Unicorn Mills, Millington, Md. (C) 108.
- Unicorn Silk Mfg. Co., Catauauga, Pa. (S) 234.
- Union Braiding Co., Sandwich, Mass. (S) 130.
- Union Carpet Lining Co., Watertown, Mass. (C) 123.
- Union Cotton Mfg. Co., Fall River, Mass. (C) 118.
- Union Cotton Mills, Lafayette, Ga. (C) 89.
- Union Cotton Mills, Maiden, N. C. (C) 192.
- Union Cotton Mills, Union, S. C. (C) 268.
- Union Feather & Wool Mfg. Co., Chicago, Ill. (W) 95.
- Union Fibre Company, Freeport, Iowa (L) 99.
- Union Hammock Co., Millbury, Mass. (C) 125.
- Union Hammock Mills, Boston, Mass. (C) 113.
- Union Hosiery Co., Laconia, N. H. (K) 145.
- Union Knitting Co., Hudson, N. Y. (K) 170.
- Union Knitting Mill, St. Johnsville, N. Y. (K) 181.
- Union Knitting Mills (E. E. Walters) 243.
- Union Mfg. Co., Frederick City, Md. (K) 108.
- Union Mfg. Co., Peterboro, N. H. (C) 147.
- Union Mfg. Co., Union Point, Ga. (C & K) 91.
- Union Mills (Aldrich Mfg. Co.) 77.
- Union Mills Co., St. Paul Park, Minn. (FD) 140.
- Union Springs Cotton Mills, Union Springs, Ala. (C) 70.
- Union St. Silk Co., Bethlehem, Pa. (S) 233.
- Union Textile Mfg. Co., Rochester, N. Y. (S) 180.
- Union Underwear Co., Piqua, O. (K) 200.
- Union Upholstery Trimming Co., New York, N. Y. (S) 177.
- Union Wadding Co., Pawtucket, R. I. (C) 257.
- Union Woolen Mill, Union, Ore. (W) 201.
- Union Woolen Mills, Union, N. H. (W) 147.
- Unionport Silk Mill, Unionport, N. Y. (S) 182.
- Uniontown Warehouse Co., Uniontown, Ala. (C) 70.
- United Cotton Mills, Manchester, Va. (C) 277.
- United Knitting Mills, Fort Wayne, Ind. (K) 97.
- U. S. Bunting Co., Lowell, Mass. (W) 124.
- U. S. Cotton Co., Central Falls, R. I. (C) 252.
- U. S. Cotton Duck Co., Baltimore, Md. (C) 108.
- U. S. Dyeing & Bleaching Co., Paterson, N. J. (D & B) 158.
- United States Finishing Co., New York, N. Y. (Norwich, Conn., Passaic, N. J., Pawtucket, R. I. (D, F, B1 & Pr) 78, 153, 177, 256.
- U. S. Knitting Co., Pawtucket, R. I. (K) 257.
- United States Knitting Mills, Hawley, Pa. (K) 238.
- United States Knitting Mills, Philadelphia, Pa. (K) 228.
- United States Knitting Mills Co., Hawley, Pa. (K) 238.
- U. S. Navy Yard, Boston, Mass. (J) 113.
- United States Rubber Co., Woonsocket, R. I. (W) 261.
- U. S. Steel Corp., Worcester, Mass. (C) 134.
- United States Thread Co., Leominster, Mass. (C) 122.
- United Waste Mfg. Co., Troy, N. Y. (C & W) 182.
- Unity Cotton Mills, La Grange, Ga. (C) 90.
- Unity Mill Co., West Union, O. (K) 201.
- Upland Mills (J. P. Crozer's Sons) 249.
- Upper Mill (Pomeroy Woolen Co.) 129.
- Upson Mfg. Co., Waynmanville, Ga. (C) 92.
- Urbahn, A. & Sons, Brooklyn, N. Y. (S) 165.
- Urbana Woolen Mills (Henry Fox & Co.) 200.
- Urner, W. C. & Co., Spring City, Pa. (K & D) 248.
- Utica Cotton Co., Capron, N. Y. (C) 166.
- Utica Dyeing Co., Utica, N. Y. (D) 183.
- Utica Hosiery Co., Utica, N. Y. (K) 183.
- Utica Knitting Co., Oriskany Falls, Utica and Sherburne, N. Y. (K) 179, 183, 181.
- Utica Knitting Mill No. 2 (Highland Knitting Mill) 182.
- Utica Spinning Co., Utica, N. Y. (C) 183.
- Utica State Hospital, Utica, N. Y. (K) 183.
- Utica Steam & Mohawk Valley Cotton Mills, Utica, N. Y. (C) 183.
- Utica Waste Co., Utica, N. Y. (C & W) 183.
- Utica Willowvale Bleaching Co., Chadwick's, N. Y. (B1 & F) 166.
- Uxbridge Cotton Mills, Whitinsville, Mass. (C) 124.
- Valatie Cotton Mill, Valatie, N. Y. (C) 183.
- Valatie Knitting Co., Valatie, N. Y. (K) 183.
- Valdese Hosiery Mills, Valdese, N. C. (K) 196.
- Valdosta Cotton Mfg. & Supply Co., Valdosta, Ga. (C) 92.
- Vale Mills (Thos. Taylor & Son) 121.
- Valentine Knitting Co., Bennington, Vt. (K) 273.
- Valentine & Bentley Silk Co., Newton, N. J., Watertown, N. Y., and Pittston, Pa. (S) 153, 184, 243.
- Valkone Dye & Finishing Works, Philadelphia, Pa. (D & F) 238.
- Valley Falls Co., Albion, R. I. (C) 251.
- Valley Falls Flax Mills (Jas. Thompson & Co.) 183.
- Valley Falls Mfg. Co., Lolo, S. C. (C) 266.
- Valley Hosiery Co., Mechanicsburg, Pa. (K) 241.
- Valley Hosiery Mill (R. F. Moyer & Co.) 240.
- Valley Mills, Providence, R. I. (W) 258.
- Valley Queen Mill, River Point, R. I. (C) 259.
- Valley of the Rocks Dye Works for Blacks (Emil Geering) 155.
- Valley Woolen Mill, Cherry Valley, Mass. (W) 114.
- Valley Woolen Mills (Cheshire Blanket Co.) 146.
- Van Alen Cotton Mills, Stuyvesant Falls, N. Y. (C) 181.
- Van Brocklin & Stover Co., Amsterdam, N. Y. (K) 163.
- Van Deventer Carpet Co., Greensboro, N. C. (W) 190.
- Van Dyke Knitting Co., Milwaukee, Wis. (K) 282.
- Van Zile Knitting Co., Greenwich, N. Y. (K) 169.
- Vance Cotton Mill Co., Chattanooga, Tenn. (C) 269.
- Vance Cotton Mills, Salisbury, N. C. (C) 194.
- Vassalboro Woolen Mills, North Vassalboro, Me. (W) 105.
- Vaughan, E., Philadelphia, Pa. (K) 228.
- Vaughn Bros. & Co., Vaughn, Va. (W) 278.

- Vaughn Knitting Mill, Winston-Salem, N. C. (K) 197.
- Vaughn, L. A. (Vaughn Knitting Mill) 197.
- Veasey & Hale, So. Groveland, Mass. (W) 131.
- Velasko, Adolph G. (Oak Knitting Co.) 181.
- Verd Mont Mills, Ludlow, Vt. (W) 275.
- Verlenden Bros., Darby, Pa. (W) 236.
- Vernon, S., Philadelphia, Pa. (K) 228.
- Vernon Woolen Co., Vernon, Conn. (W) 81.
- Versen, Albert F., New York, N. Y. (D) 177.
- Vesta Knitting Mills, Providence, R. I. (K) 259.
- Victor Cotton Mills, Charlotte, N. C. (C) 187.
- Victor Hosiery Mills, Kernersville, N. C. (K) 191.
- Victor Knitting Mill Co., Little Falls, N. Y. (K) 171.
- Victor Knitting Mills Co., Cohoes, N. Y. (K) 167.
- Victor Mfg. Co., Greer Depot, S. C. (C) 265.
- Victoria Carpet Mill (Thos. Develon's Sons) 211.
- Victoria Cotton Mill, Rock Hill, S. C. (C) 267.
- Victoria Knitting Mills (Querns Bros.) 224.
- Victoria Mill (Wm. F. Read) 225.
- Victoria Mills, Thornton, R. I. (W) 260.
- Victoria Plush Mill, Swarthmore, Pa. (S) 248.
- Victory Webbing Co., North Abington, Mass. (C) 127.
- Viedt, Louis (American Buffalo Robe Co.) 160.
- Vienna Dye Works (A. Eichler & Co.) 213.
- Vigilant Mills, Philadelphia, Pa. (S) 228.
- Vigilant Mills (Wallace Wilson) 230.
- Virghna Cotton Mills, Swepsonville, N. C. (C) 195.
- Virginia Hosiery Mills, Norfolk, Va. (K) 277.
- Virginia Textile Co., Lynchburg, Va. (K) 277.
- Virginia Woolen Co., Winchester, Va. (W) 278.
- Vivian Cotton Mills, Cherryville, N. C. (C) 187.
- Voell, Anthony, Philadelphia, Pa. (S) 228.
- Vogler, John G., Philadelphia, Pa. (W) 228.
- Vogt Mfg. & Coach Lace Co., Rochester, N. Y. (S) 180.
- Vogt, Walter J., Brooklyn, N. Y. (S) 165.
- Voorhees Mfg. Co., Graham, N. C. (C) 189.
- Wabash Mills (Simpson Bros.) 226.
- Wabash Mills Co., Philadelphia, Pa. (C & W) 228.
- Wachusett Mills, Worcester, Mass. (C) 134.
- Wachusett Thread Co., Worcester, Mass. (C) 134.
- Waco Cotton Mill, Waco, Tex. (C) 272.
- Waco Knitting Mill, Waco, N. C. (K) 196.
- Waco Knitting Mills, Waco, Tex. (K) 272.
- Wadesboro Cotton Mills Co., Wadesboro, N. C. (C) 196.
- Wadesboro Silk Co., Wadesboro, N. C. (S) 196.
- Wadsworth Braiding Co., Providence, R. I. (C) 259.
- Wagner, James H. & Co., Mohrsville, Pa. (K) 241.
- Wagner & Heckman, Shoemakersville, Pa. (K) 247.
- Wahneta Mills, Cedartown, Ga. (K) 86.
- Wahnetah Silk Co., Catasauqua, Pa. (S) 234.
- Wahoo Mfg. Co., Sargent, Ga. (C) 91.
- Waiontha Knitting Co., Ltd., Richfield Springs, N. Y. (K) 179.
- Waite's Perfection Bandage Co., Lowell, Mass. (C) 124.
- Wakefield Knitting Co. (Why Bros. & Co.) 229.
- Wakefield Mill (Rodman Mfg. Co.) 254.
- Walbert, William, Allentown, Pa. (K) 231.
- Walcott & Campbell Spinning Co., New York Mills, N. Y. (C) 178.
- Waldensian Hosiery Mill, Valdese, N. C. (K) 196.
- Walder, H. (Comby Silk Mills) 159, 246.
- Waldrich Bleachery, Delawanna, N. J. (Bl. D & F) 149.
- Walhalla Cotton Mills, Walhalla, S. C. (C) 268.
- Walker Bros., Chelsea, Mass. (D) 114.
- Walker, Dennison, East Willington, Conn. (W) 75.
- Walker, Geo., Highlandville, Mass. (K) 120.
- Walker, Isaac, Philadelphia, Pa. (C) 228.
- Walker, J. G., Brooksville, Me. (W) 162.
- Walker Mills, The E. Wilton, Me. (W) 103.
- Walker, Robert J., Est. of, Philadelphia, Pa. (F) 228.
- Walker & Harp Mfg. Co., Cohoes, N. Y. (C) 167.
- Walker & Williams Mfg. Co., Cohoes, N. Y. (C) 168.
- Wall, E., Jr., Fort Ann, N. Y. (K) 169.
- Wall, Wm. F., Brooklyn, N. Y. (S) 165.
- Wall & Davies, Philadelphia, Pa. (C) 228.
- Wallace, J. H. & Bro., Philadelphia, Pa. (W) 228.
- Wallace, J. L., Jackson, Minn. (Fl) 139.
- Wallister, August, Philadelphia, Pa. (S) 229.
- Wallister's, Chas., Sons, Philadelphia, Pa. (S) 229.
- Walkill Hat Works, Middletown, N. Y. (W) 172.
- Wallworth, J. & Sons, Upland, Pa. (W) 249.
- Walpole Dye & Bleach Works (The S. Gray & Co.) 132.
- Walrath, Eugene, Little Falls, N. Y. (K) 169.
- Walsh Mill, Lowell, Mass. (W) 124.
- Walsh, Wm. E., Lowell, Mass. (W) 124.
- Walter, F. W. & Co., Philadelphia, Pa. (W) 229.
- Walter & Bell, Brooklyn, N. Y. (J) 165.
- Walters, E. E., Phoenixville, Pa. (K) 243.
- Walters & Felner, Webster, W. Va. (W) 280.
- Waltham Bleachery & Dye Works, Waltham, Mass. (Bl & D) 132.
- Walther, Louis & Co., Philadelphia, Pa. (W) 229.
- Walton Cotton Mill Co., Monroe, Ga. (C) 90.
- Walworth Bros., Lawrence, Mass. (W) 122.
- Wampanoag Mills, Fall River, Mass. (C) 118.
- Wamsutta Mills, New Bedford, Mass. (C) 126.
- Wanita Mills Co., Enterprise, Miss. (W) 140. (Also see Too Late Classification List)
- Wanskuck Co., Mohegan (Geneva Mill), Providence, R. I. (W) 254, 258, 259.
- Wapak Knitting Co., The, Wakaponeta, O. (K) 200.
- Warburton, H. A. & F. E. (Flossette Mfg. Co.) 256.
- Ward, James, Philadelphia, Pa. (K) 229.
- Ward, Jas. B. & Bro., Philadelphia, Pa. (C) 229.
- Wardlow, J. & W., Philadelphia, Pa. (C) 229.
- Wardwell & Co., Converse, Ind. (W) 96.
- Ware Woolen Mills (Chas. H. Stevens & Co.) 133.
- Warehouse Point Silk Co., Warehouse Point, Conn. (S) 81.
- Warfield, S. R., Oakdale, Mass. (C) 128.
- Warnecke, A. F., York, Pa. (W) 251.
- Warner, Joseph, Paterson, N. J. (S) 158.
- Warner's, John, Sons, Amsterdam, N. Y. (K) 163.
- Warp Knitting Mill, Rochdale, Mass. (K) 130.
- Warren Cotton Mills, West Warren, Mass. (C) 123.
- Warren Featherbone Co., Middleville, Mich. (C & S) 128.
- Warren Mfg. Company, Warren, Md. (C) 109.
- Warren Mfg. Co., Warrenville, S. C. (C) 268.
- Warren Mfg. Co., Warren, R. I. (C) 260.
- Warren Mfg. Co., Oregon, Tenn. (C) 270.
- Warren, W., Thread Works, Westfield, Mass. (C & D) 132.
- Warren Woolen Co., The, Stafford Springs, Conn. (W) 80.
- Warrensburgh Woolen Co., Warrensburgh, N. Y. (W) 183.
- Warrenton Woolen Co., The, Torrington, Conn. (W) 81.
- Warsaw Knitting Mills, Warsaw, N. Y. (K) 183.
- Warwick Cotton Mills, Augusta, Ga. (C) 86.
- Warwick Mills, Centerville, R. I. (C) 253.
- Washburn, A. & Son, So. Coventry, Conn. (S) 80.
- Washburn, E. L., New Haven, Conn. (K) 77.
- Washington Examining, Sponging & Refinishing Works, New York, N. Y. (F) 178.
- Washington Knitting Mill, Washington, N. C. (K) 196.
- Washington Mills, Lawrence, Mass. (W) 122.
- Washington Mills (Wm. Enslley & Bro.) 213.
- Washington Mills, Fries, Va. (C) 277.
- Washington Silk Mills, Washington, N. J. (S) 159.
- Wassookeag Woolen Co., Dexter, Me. (W) 103.
- Watching Silk Co., Plainfield, N. J. (S) 158.
- Waterbury, H., Sons Co., Oriskany, N. Y. (W) 178.
- Waterbury Rope Co., Brooklyn, N. Y. (J) 165.
- Waterford Dye Works, Waterford, N. Y. (D) 183.

- Waterford Knitting Co., Waterford, N. Y. (K) 183.
- Waterhead Mills, Lowell, Mass. (C & D) 124.
- Waterhouse, John, Providence, R. I. (W) 259.
- Waterhouse & Buffum, Blackinton, Mass. (W) 111.
- Waterloo Woolen Mfg. Co., Waterloo, N. Y. (W) 182.
- Waterman, Felix, New York, N. Y. (S) 178.
- Waters, D. P., Philadelphia, Pa. (D) 229.
- Watertown Tow Mill, Watertown, S. D. (F) 268.
- Watertown Woolen Mills (Geo. A. Lance) 184.
- Waternliet Mills (Jas. Roy & Co.) 184.
- Watkinson, George & Co., Philadelphia, Pa. (K) 229.
- Watt, John C., Brooklyn, N. Y. (W) 165.
- Watt, Wm. & Son, Norristown, Pa. (W) 243.
- Watt & Bro., Philadelphia, Pa. (W) 229.
- Watt's, John, Sons, Philadelphia, Pa. (W) 229.
- Waucanuck Mills (C. A. Root & Co.) 132.
- Waukenhose Mfg. Co., Lowell, Mass. (K) 124.
- Wauregan Co., Wauregan, Conn. (C) 81.
- Waverly Mills (Wm. Clarke) 209.
- Waverly Woolen Co., Pittsfield, Me. (W) 106.
- Waverly Worsted Co., Philadelphia, Pa. (W) 229.
- Waxahachie Cotton Mills, Waxahachie, Tex. (C) 272.
- Waxler, Jno. L., Philadelphia, Pa. (D) 229.
- Way Knitting Mills Co. (K) 234.
- Waycross Knitting Mill, Waycross, Ga. (K) 92.
- Wayne Cotton Mills, Goldsboro, N. C. (C) 189.
- Wayne Co. Knitting Mills, Hawley, Pa. (K) 238.
- Wayne Junction Spinning Co., Philadelphia, Pa. (W) 229.
- Wayne Knitting Mills, Fort Wayne, Ind. (K) 97.
- Waynesboro Hosiery Mill, Waynesboro, Pa. (K) 249.
- Waynesville Woolen Mills, Waynesville, N. C. (W) 196.
- Wayside Knitting Co., Troy, N. Y. (K) 182.
- Weaver, S. F., Ephrata, Pa. (K) 237.
- Webb, H. F. (Pulaski Woolen Mill) 271.
- Webb, T. A. W. & Son, Allensville, Pa. (W) 231.
- Weber, Albert, Reading, Pa. (K) 246.
- Weber, Chas., Philadelphia, Pa. (K) 229.
- Weber, Edward, Philadelphia, Pa. (W) 229.
- Weber, Louis & Co., Philadelphia, Pa. (K) 229.
- Weber, R. A. (College Point Silk Dyeing Co.) 168.
- Weber & Co., Philadelphia, Pa. (D) 229.
- Weber & Co., Reading, Pa. (K) 246.
- Weber & Ederer Mfg. Co., Seattle, Wash. (C) 278.
- Webster, Jonathan & Co., Rushford, Minn. (W) 140.
- Webster, M. & Sons, La Crescent, Minn. (W) 139.
- Webster Mfg. Co., Suncook, N. H. (C) 147.
- Webster Woolen Co., Sabattus, Me. (W) 106.
- Wedge, John, Philadelphia, Pa. (K) 229.
- Weedon Mfg. Co., Providence, R. I. (C) 259.
- Weeks, F. D., Extracting Co., Shirley, Mass. (W) 120.
- Weetamoc Mills, Fall River, Mass. (C) 118.
- Wehadkee Cotton Mills, Rock Mills, Ala. (C) 69.
- Wehrlin & Brugger, College Point, N. Y. (D) 168.
- Wehrlin, John, New York, N. Y. (S) 178.
- Weidmann Silk Dyeing Co., Paterson, N. J. (D) 158.
- Weirman, Chas. S., Philadelphia, Pa. (K) 229.
- Weizle & Finke, New York, N. Y. (D) 178.
- Wellbacher, Frank, Allentown, Pa. (S) 231.
- Welmar Bros., Philadelphia, Pa. (C & S) 229.
- Weinman, Thos. & Sons, Philadelphia, Pa. (D) 229.
- Weinz Trimming Co., Boston, Mass. (S) 113.
- Weiss, J., New York, N. Y. (K) 178.
- Weissfog, E. F. (Gera Mills) 153.
- Welch, H. L., Hosiery Co., Waterville, Conn. (K) 81.
- Welch, J. H., Est. of, Baraboo, Wis. (K) 280.
- Welchert, Herman, Brooklyn, N. Y. (K) 165.
- Welcome Mfg. Co., Philadelphia, Pa. (C) 229.
- Weldon Cotton Mfg. Co., Weldon, N. C. (C) 196.
- Wellington Mills (John Gardner & Son) 215.
- Wells Woolen Co., Neshkora, Wis. (W) 282.
- Wenonah Cotton Mills, Lexington, N. C. (C) 191.
- Werner, Ferd, Philadelphia, Pa. (W) 229.
- Wertheimer & Hollander, New York, N. Y. (K) 178.
- Wertz, A. B., Brodbeck's, Pa. (W) 234.
- Wescott, H. T. (Whitestone Mill) 75.
- Wessel Dyeing & Proofing Co., New York, N. Y. (D & F) 178.
- West, Ambrose (Pioneer Knitting Mills) Plymouth and Ashley, Pa. 229, 239, 233.
- West Boylston Mfg. Co., Easthampton, Mass. (C) 115. (Also see Too Late Classification List)
- West Branch Hosiery Co., Milton, Pa. (K) 241.
- West Bros., Syracuse, N. Y. (K) 181.
- West Buxton Mill (Martin & Marble) 107.
- West Cotton Mills, West, Tex. (C) 272.
- West End Flax Mills, Millbury, Mass. (FD) 125.
- West End Knitting Mill (Samuel Unger) 244.
- West End Mill (Lecha Silk Co.) 231.
- West End Mills (H. S. Henry) 217.
- West Huntsville Cotton Mills Co., Huntsville, Ala. (C) 69.
- West Plains Woolen Mills, West Plains, Mo. (W) 142.
- West Point Cotton Mills, West Point, Miss. (C) 141.
- West Point Mfg. Co., West Point, Ga. (C) 92.
- West, Samuel, Philadelphia, Pa. (K) 229.
- West Shore Knitting Mills, Amsterdam, N. Y. (K) 163.
- West Side Knitting Mills Co., New York, N. Y. (K) 178.
- W. Swanzy Mfg. Co., W. Swanzy, N. H. (W) 148.
- West, Thomas, Danville, Millheim, Nanticoke, Plymouth, Pa. (K) 236, 241, 242, 244.
- Westboro Weaving Co., Westboro, Mass. (C) 133.
- Westerhoff Bros. & Napier Co., Jamesburg, Paterson, N. J., and Denver, Ephrata, Pa. (S) 151, 158, 236, 237.
- Westerly Silk Mill Co., Westerly, R. I. (S) 260.
- Westerly Woolen Co., Westerly, R. I. (W) 260.
- Westerman, S. A., Philadelphia, Pa. (C & S) 229.
- Western Electric Co., Chicago, Ill. (C) 95.
- Western Felt Works, The, Chicago, Ill. (W) 95.
- Western Fibre Co. (Wm. H. Payne) 199.
- Western Knitting Mills, Rochester, Mich. (K) 138.
- Western Penitentiary of Pa., Allegheny, Pa. (K) 221.
- Western Reserve Woolen Mills (W. E. Starr) 200.
- Western Robe Co., Detroit, Mich. (K) 137.
- Western Shade Cloth Co., Chicago, Ill. (C) 95.
- Western Wool Mfg. Co., San Francisco, Cal. (W) 72.
- Western Woolen Co., Topeka, Kansas (W) 100.
- Western & Wells Mfg. Co., The, Philadelphia, Pa. (C) 229.
- Westmoreland Dye Works, Philadelphia, Pa. (D) 229.
- Westport Mfg. Co., Fall River, Mass. (C) 118.
- Westville Mill (Duffon Bros.) 131.
- Weybosset Mills, Providence, R. I. (W) 259.
- Weyers, M. (New York Corduroy Mills) 176.
- Whartenby, Edward F., Philadelphia, Pa. (K) 229.
- Wheaton, Simeon A., Phenixville, Conn. (C) 78.
- Wheeler, J. W. & Son, Salem, N. H. (W) 147.
- Wheeling Weaving Mills Co., Moundsville, W. Va. (C) 279.
- Whipple, J. L., Los Angeles, Cal. (W) 71.
- Whitaker, J. & Bro., Philadelphia, Pa. (W) 229.
- Whitaker, Wm. D., Philadelphia, Pa. (C) 229.
- Whitaker, Wm. & Sons, Philadelphia, Pa. (C) 229.
- White, A. W., Philadelphia, Pa. (D) 229.
- White Bros., Smithville, Mass., and East Jeffrey, N. H. (C) 130, 143.
- White, C. W. & Co., Boston, Mass. (K) 113.
- White Haven Silk Co., White Haven, Pa. (S) 249.
- White, Jos., Paterson, N. J. (S) 158.
- White, N. D. & Sons, Winchendon, Mass. (C) 134.
- White, Oliver L., Wellsboro, Pa. (W) 249.
- White Rock Mfg. Co., White Rock, R. I. (C) 260.
- White, Samuel, Philadelphia, Pa. (W) 229.
- White Valley Mills, Smithville, Mass. (C) 130.
- White, Wm. (White Wool Scouring Co.) 160.

- White, Williamson & Co., Saxapahaw, N. C. (C) 195.
- White Wool Scouring Co., East Las Vegas, New Mexico (W) 160.
- Whitehall Yarn Mill, White Hall, Ga. (C) 92.
- Whitehead, James, Jr., Springville, Utah (W & K) 273.
- Whitknit Mills (Leroy E. Whiting) 77.
- Whitestone Mill, East Killingly, Conn. (C) 75.
- Whitin, Paul, Mfg. Co. (Rockdale Mill) 128.
- Whiting, John C., Norwood, R. I. (C) 255.
- Whiting, Leroy E., New Haven, Conn. (C) 77.
- Whitinsville Cotton Mills, Whitinsville, Mass. (C) 134.
- Whitman Bros. (Rockton Knitting Mills) 171.
- Whitman Mills, New Bedford, Mass. (C) 126.
- Whitney Mfg. Co., Whitney, S. C. (C) 268.
- Whitney Woolen Co., Geo., So. Royalston, Mass. (W) 121.
- Whittall & Thomas, Worcester, Mass. (W) 135.
- Whittall, M. J., Worcester, Mass. (W) 135.
- Whittam Textile Co., The, Asheville, N. C. (C) 184.
- Whittenton Mfg. Co., Taunton, Mass. (C) 131.
- Whittier Mills, Chattahoochee, Ga., and Springfield, Mass. (C & D) 86, 131.
- Whittington Mill (Oliver Lupton & Co.) 221.
- Whittle Dye Works, Bellefont, R. I. (D & F) 251.
- Why Bros. & Co., Philadelphia, Pa. (K) 229.
- Why, Thomas, Philadelphia, Pa. (K) 229.
- Wicke, Wm., Co., New York, N. Y. (C) 178.
- Wickford Worsted Mills, Wickford, R. I. (W) 260.
- Wiconisco Dyeing & Mfg. Co., Wiconisco, Pa. (D) 250.
- Wiconisco Hosiery Mill (Isaac Mossop & Co.) 250.
- Wiertz, Augusta, Paterson, N. J. (S) 158.
- Wienburg, C. & Co., New York, N. Y. (S) 178.
- Wierner, Martha & Co., New York, N. Y. (S) 178.
- Wiggin's, H. B., Sons, Bloomfield, N. J. (C) 148.
- Wilby, J. F. & Co., Darby, Pa. (W) 236.
- Wild, Jos. & Co. (Nassau Mills), Astoria and Brooklyn, N. Y. (W) 163, 165.
- Wild Mfg. Co., Valatie, N. Y. (C) 183.
- Wilde, Jno. & Bro., Philadelphia, Pa. (W) 229.
- Wilde & Co., Hazelton, Pa. (K) 229.
- Wilde's, Robert, Sons, Philadelphia, Pa. (W) 229.
- Wildman & Co., Paterson, N. J. (S) 158.
- Willey Mfg. Co., Catskill, N. Y. (K) 166.
- Wilhoite, W. L., Shelbyville, Tenn. (K) 271.
- Wilkesbarre Knitting Mills, Wilkesbarre, Pa. (K) 250.
- Wilkesbarre Lace Mfg. Co., Wilkesbarre, Pa. (C) 250.
- Wilkinson, E. & Son, Philadelphia, Pa. (C) 229.
- Wilkinson, Seth, Pawtucket, R. I. (S) 257.
- Willard Bag & Mfg. Co., Wilmington, N. C. (J) 196.
- Willard Mfg. Co., Willardville, N. C. (C) 196.
- Willcox, Samuel E., Philadelphia, Pa. (C) 230.
- Willley, John Henry, Philadelphia, Pa. (W) 230.
- Williamette Valley Woolen Mfg. Co., Eugene, Ore. (W) 201.
- Williams, A. & Co., So. Woodstock, Conn. (C) 80.
- Williams, B. F., Bloomery, W. Va. (W) 279.
- Williams Bros. Mfg. Co., Rome, N. Y. (K) 180.
- Williams, C. A. & Bros. (Winchester Woolen Mills) 278.
- Williams, Roger, Cotton Mills, Arcadia, R. I. (C) 251.
- Williams Duck Mill, Moodus, Conn. (C) 77.
- Williams, J. F., Shelby, N. C. (K) 195.
- Williams, John, Mfg. Co., Trenton, N. J., and Philadelphia, Pa. (W) 159, 230.
- Williams Knitting Co., Birmingham, Ala. (K) 67.
- Williams Mfg. Co., John, Philadelphia, Pa. (W) 230.
- Williams, M. & C., Trucksville, Pa. (W) 249.
- Williams, Philip H., Son & Co., New York, N. Y. (S) 173.
- Williams Silk Mfg. Co., New York, N. Y. (S) 178.
- Williams, Thos., Worcester, Mass. (W) 134.
- Williams, T. A. & Co., Hazelton, Pa. (K) 239.
- Williams & Fairley (Murchison Cotton Mills) 192.
- Williamsburg Knitting Mill Co., Williamsburg, Va. (K) 278.
- Williamsburg Knitting Mills, Brooklyn, N. Y. (K) 165.
- Williamson, Jas. & Co., Philadelphia, Pa. (W) 230.
- Williamson, Jas. N. & Sons, Elon College, N. C. (C) 188.
- Williamson, Jas. N. & W. W. (Pilot Cotton Mills) 192.
- Williamspert Woolen Mill (H. E. & J. C. Holt-spert) 250.
- Williamston Mills, Williamston, S. C. (C) 268.
- Williamstown Hosiery Mill (J. W. Durbin & Sons) 250.
- Williamstown Mfg. Co., Williamstown, Mass. (C) 134.
- Williamsville Mfg. Co., The, Killingly, Conn. (C) 76.
- Willmantic Cotton Mill Corporation, Willmantic, Conn. (C) 83.
- Willmantic Linen Co., Willmantic, Conn. (C) 83.
- Williamham Cotton Mills, Macon, Ga. (C) 90.
- Willis, Z. H., Summerville, Mich. (W) 139.
- Wilmington Cotton Mills, Wilmington, N. C. (C) 196.
- Wilmington Hosiery Co., The, Wilmington, Del. (K) 84.
- Wilson Braiding & Embroidery Co., Chicago, Ill. (S) 95.
- Wilson Cotton Mills, Wilson, N. C. (C) 196.
- Wilson, Herbert M., Bridgton, R. I. (W) 251.
- Wilson, James (Taconic Mills) 129.
- Wilson, James & Sons, Philadelphia, Pa. (C) 230.
- Wilson, Samuel, Highlandville, Mass. (K) 120.
- Wilson, Thomas H., Philadelphia, Pa. (W) 230.
- Wilson, Wallace, Philadelphia, Pa. (K) 230.
- Wilson's, Chas., Sons, Philadelphia, Pa. (D & Pr) 230.
- Wilton Hygiene Underwear Knitting Co., Philadelphia, Pa. (K) 230.
- Wilton Wool Scouring Mills, Hyde Park (W) 121.
- Wilton Woolen Co., Wilton, N. H. (W) 148.
- Wilton Woolen Mills, Wilton, Me. (W) 107.
- Wiltshire, C. (Chicago Glove & Mitten Co.) 93.
- Wiltshire Mfg. Co., Philadelphia, Pa. (W & C) 230.
- Winch, Chas. E. & Frank W. Janney (Electric Dye Works) 213.
- Winchester Woolen Mill (J. D. Carter) 98.
- Winchester Woolen Mills, Winchester, Va. (W) 278.
- Windemere Knitting Mill, Albermarle, N. C. (K) 184.
- Winder Cotton Mills, Winder, Ga. (C) 92.
- Windle, A. D. & W. W., West Millbury, Mass. (W & D) 132.
- Windham Mfg. Co., Willmantic, Conn. (C) 83.
- Windham Silk Co., Willmantic, Conn. (S) 83.
- Windsor Co., North Adams, Mass. (D, Bl & Pr) 127.
- Windsor Cotton Mill (R. L. & J. H. Holt, Jr.) 185.
- Windsor Knitting Mills, Brooklyn, N. Y. (K) 165.
- Windsor Knitting Mills, Hagerstown, Md. (K) 108.
- Windsor Silk Co., Windsor Locks, Conn. (S) 83.
- Winfield Mfg. Co., Philadelphia, Pa. (C & W) 220.
- Winger & Winger, Little Falls, Wis. (W) 251.
- Wingohocking Hosiery Mills, Philadelphia, Pa. (K) 223.
- Wingohocking Mills Co., Philadelphia, Pa. (C) 230.
- Wink, B. & Co., Philadelphia, Pa. (W) 230.
- Winn, D. J. & Co., Bowman, Ga. (W) 86.
- Winner, K. P., Pleasant Mount, Pa. (W) 244.
- Winola Worsted Yarn Co., Tunkhannock, Pa. (W) 249.
- Winona Cotton Mills, Winona, Miss. (C) 141.
- Winona Mills (Columbia Hosiery Co.) 174.
- Winship, Bolt & Co., Wakefield, Mass. (K) 132.
- Winsted Hosiery Co., The, Winsted, Conn. (K) 82.
- Winsted Silk Co., West Winsted, Conn. (S) 83.
- Winsted Yarn Co., Winsted, Conn. (W) 83.
- Winston Knitting Mills, Winston-Salem, N. C. (K) 197.

- Winters, Samuel (West Shore Knitting Mills) 163.  
 Winton Knitting Mills, Winton, N. C. (K) 197.  
 Winthrop Mill, Taunton, Mass. (C) 131.  
 Winthrop Mills Co., Winthrop, Me. (C & W) 107.  
 Wiscasset Mills Co., Albermarle, N. C. (C) 184.  
 Wisconsin Industrial School for Boys, Waukesha, Wis. (K) 282.  
 Wisconsin Knitting Co., Racine, Wis. (K) 282.  
 Wisconsin Knitting Works, Milwaukee, Wis. (K) 282.  
 Wissahickon Dye Works, Camden, N. J. (D) 149.  
 Wissahickon Knitting Mills (Thos. Mottram) 222.  
 Wissahickon Worsted Mills (H. C. Ball & Co.) 203.  
 Witbeck & Cunningham Bros., Mechanicville, N. Y. (W & C) 172.  
 Witham Cotton Mills, The, Hartwell, Ga. (C) 89.  
 Witte, Albert & Sons, Petoskey, Mich. (K) 138.  
 Witter, H. M. & Co., Worcester, Mass. (C) 135.  
 Witty, Chas. H. & Co., Philadelphia, Pa. (C) 230.  
 Wolf & Newman, New York, N. Y. (S) 178.  
 Wolfboro Woolen Mills, South Wolfboro, N. H. (W) 147.  
 Wolfe, Wm. & Son, Shoemakersville, Pa. (K) 247.  
 Wolfenden, R. & Sons, Attleboro, Mass. (D & B) 111.  
 Wolfenden, Shore & Co., Ltd., Cardington, Pa. (C & W) 234.  
 Wolfley, J. D., Lanark, Ill. (W) 96.  
 Wolgamuth's, F. F., Sons, Philadelphia, Pa. (C & S) 230.  
 Wolsey, W., Clare, Mich. (K) 137.  
 Wolstencroft, Wm., Philadelphia, Pa. (W) 230.  
 Wolstenholme, Thos., Sons & Co., Philadelphia, Pa. (W) 230.  
 Wolstenholme & Clarke, Philadelphia, Pa. (W) 220.  
 Wood, Cyrus G. & Co., Quinapoxet, Mass. (W) 129.  
 Wood, D. F. & Co. (Woodside Mills) 128.  
 Wood Dyeing Co., The Peter, Worcester, Mass. (D & B) 135.  
 Wood, E. R. (Active Knitting Mills) 244.  
 Wood, Frank, Mfg. Co., Valley Falls, R. I. (S) 260.  
 Wood, H. H. & Co., Lakeport, N. H. (K) 145.  
 Wood, Samuel, Philadelphia, Pa. (W) 230.  
 Wood, S. C., Pittsfield, Mass. (K) 129.  
 Wood, T. H., So. Coventry, Conn. (S) 80.  
 Wood & Logan, Philadelphia, Pa. (C) 230.  
 Woodberry Mfg. Co., Baltimore, Md. (C) 108.  
 Woodcock Bros., Philadelphia, Pa. (K) 230.  
 Woodcock & Curry, Waterside, Pa. (W & K) 249.  
 Woodcock & Kinzel, Philadelphia, Pa. (K) 230.  
 Woodhead, I. C., Philadelphia, Pa. (C & S) 230.  
 Woodhead, Joseph, Falmouth, Ky. (W) 100.  
 Woodhead, L. R., Philadelphia, Pa. (C & S) 230.  
 Woodhouse, Bopp & Co., New York, N. Y. (S) 178.  
 Woodruff Cotton Mills, Woodruff, S. C. (C) 268.  
 Woodside Mills, Northboro, Mass. (W) 128.  
 Woodstock Cotton Mills, The, Anniston, Ala. (C) 67.  
 Woodstock Mills Co., Norristown, Pa. (W) 243.  
 Woonsocket Worsted Mills, Woonsocket, R. I. (W) 261.  
 Worcester Bleach & Dye Works Co., Worcester, Mass. (B1 & D) 135.  
 Worcester Carpet Mill, Worcester, Mass. (W) 135.  
 Worcester Dusting Mill, Worcester, Mass. (W) 125.  
 Worcester Textile Co., Franklin, Mass. (C & F) 119.
- Worcester Thread Co., Worcester, Mass. (F1) 135.  
 (See also Too Late Classification List)  
 Worcester Woolen Mill Co., The, Worcester, Mass. (W) 125.  
 Worley Bros., Mohn's Store, Pa. (W) 241.  
 Worley Hosiery Co., Mohn's Store, Pa. (K) 241.  
 Worth Mfg. Co., Central Falls and Worthville, N. C. (C) 185, 197.  
 Worthen & Aldrich Co. (Waldrich Bleachery and Manhattan Print Works) 149, 153.  
 Worumbo Mfg. Co., Lisbon Falls, Me. (W) 105.  
 Wright, Allen (Downtown Woolen Mill) 269.  
 Wright, H. K., Wegatchie, N. Y. (W) 184.  
 Wright Mfg. Co., Lawrence, Mass. (W) 122.  
 Wright, M. & Son (Keystone Hosiery Co.) 239.  
 Wright, S. D. & Co., Philadelphia, Pa. (C) 230.  
 Wright, Wm. L., Philadelphia, Pa. (W) 230.  
 Wright's Health Underwear Co., Hoboken, N. J., Troy, N. Y., and Pownal, Vt. (K) 151, 182, 275.  
 Wrightson, R. N., Philadelphia, Pa. (K) 230.  
 Wust, Edward, Cincinnati, O. (K) 198.  
 Wylie Mfg. Co., W. H., The, Wyoming, R. I. (S) 261.  
 Wylie Mill, Chester, S. C. (C) 263.  
 Wyman, L. J., Smithfield, Me. (W) 107.  
 Wye, Geo. E., Needham, Mass. (K) 126.  
 Wye, Wm. H. & Co., Needham, Mass. (K) 126.  
 Wyoming Flock Co., Wyoming, R. I. (W) 261.  
 Wyoming Valley Knitting Mills (Thos. West) 244.  
 Wyoming Valley Lace Mills, Wilkesbarre, Pa. (C & S) 250.  
 Wyoming Hosiery Co., Mohn's Store and Reinholds, Pa. (K) 241, 246.  
 Wytheville Woolen & Knitting Mills Co., Wytheville, Va. (W & K) 278.  
 Yale Woolen Mills, Yale, Mich. (W) 129.  
 Yanney, Levi, Ephratah, N. Y. (W) 168.  
 Yantic Woolen Co., Yantic, Conn. (W) 83.  
 Yates & Co., C. H. (Athletic Knitting Co.) (Utica Hosiery Co.) 182, 183.  
 Yawgao Woolen Co. (B. A. Clark) 259  
 Yazoo Cotton Mills, Yazoo City, Miss. (C) 141.  
 Yeardall & Jones, Philadelphia, Pa. (W) 230.  
 Yocom, Harry Y., Grill, Pa. (K) 238.  
 Yocona Mills, Water Valley, Miss. (C) 141.  
 York Carpet Mills (Frank Frysinger) 250.  
 York Cotton Mills, York, S. C. (C) 268.  
 York Knitting Mills Co., York, Pa. (K) 251.  
 York Mfg. Co., Saco, Me. (C) 106.  
 York Silk Mfg. Co., York, Pa. (S) 251.  
 Yorks, F. G. (Lock Haven Silk Co.) 240.  
 Young, B. C., East Killingly, Conn. (W) 75.  
 Young, John B., Philadelphia, Pa. (C) 230.  
 Young, W. J. (Towanda Knitting Mills) 249.  
 Young, Wm. M., Philadelphia, Pa. (C & S) 230.  
 Yount Woolen Mills Co., Yountsville, Ind. (W) 98.  
 Yund, Kennedy & Yund, Amsterdam, N. Y. (K) 163.  
 Zanderer, J. Ch., New York, N. Y. (S) 178.  
 Zanesville Woolen Mfg. Co., Zanesville, O. (W) 201.  
 Zengerl Bros., Philadelphia, Pa. (W) 230.  
 Ziegler, Conrad, Boston, Mass. (D) 113.  
 Zimmerman, The Chn. Son Co., Jersey City, N. J. (K) 152.  
 Zinderstein, Chas. A. (Rionor Silk Mills) 231.  
 Zion Lace Industries, Zion City, Ill. (C) 96.  
 Zook, John K., West Earl, Pa. (W) 249.  
 Zorn, W. J. (West Plains Woolen Mills) 142.  
 Zulzbach, A. (New York Watering Co.) 176.

## CANADA.

- Adams, Geo., Uxbridge, Ont. (F1) 292.  
 Algie, Wm., Alton, Ont. (K) 285.  
 Allen, Joseph (British American Dyeing Co.) 293.  
 Allport, D., Smith Falls, Ont. (W) 291.  
 Albright, M. (Merritt Knitting Mill) 289.  
 Almonte Blanket Co., Almonte, Ont. (W) 285.  
 Almonte Knitting Co., Ltd. Almonte, Ont. (K) 285.  
 Alton Knitting Mills (John M. Dodd) 285.  
 Anchor Carpet Mills, Paisley, Ont. (W) 290.  
 Anchor Knitting Co., Ltd., Almonte, Ont. (K) 285.

- Antigonish Woolen Mill Co., Antigonish, N. S. (W) 283.
- Armitage, P. H. (Coaticook Woolen Co.) 293.
- Arthur Woolen Mills (J. B. McCormack) 285.
- Auburn Woolen Co., Ltd., Peterboro, Ont. (W) 290.
- Ayotte, P. V. (Canadian Web Co.) 294.
- Bain & Co., Flora, Ont. (W) 287.
- Baker, H. & Co., Stratford, Ont. (W) 291.
- Balfour Woolen Factory (James Matheson) 285.
- Barber, M. G. & Son, Port Elgin, Ont. (W) 290.
- Barnston Woolen Mill Co., Ways Mills, Que. (W) 294.
- Barrington Woolen Mills, Barrington, N. S. (W) 283.
- Bauer, A. & Co., Waterloo, Ont. (W) 292.
- Beaumont, Joseph, Glen Williams, Ont. (W & K) 288.
- Beaver Mills (Wm. Algie) 285.
- Belding, Paul & Co., Montreal, Que. (S) 292.
- Bellerby, N. C. & Co., Shelburne, Ont. (K) 291.
- Berlin Feet Boot Co., Berlin, One. (W & K) 286.
- Bird, Henry J., Bracebridge, Ont. (W) 286.
- Black, J. & G., Thurso, Que. (W) 294.
- Bloomfield Woolen Mills, Bloomfield, Ont. (W) 286.
- Bolton Woolen Mills, Bolton, Ont. (W) 286.
- Booth, E. M. (Odessa Woolen Mills Co.) 290.
- Brantford Branch (Dominion Cotton Mills Co.) Brantford, Ont. (C) 286.
- Brantford Linen Mfg. Co., Brantford, Ont. (C) 286.
- British American Dyeing Co., Montreal, Quebec (D) 293.
- Brodie Mills (Canada Woolen Mills), Hespler, Ont. (W) 288.
- Brook, B. F. (Listowel Woolen Mills) 298.
- Brook Woolen Co., Ltd., Simcoe, Ont. (W) 291.
- Brown, John, Hornings Mills, Ont. (W & K) 288.
- Brown, W. & C., Keenansville, Ont. (W & K) 288.
- Brown & Wigle Co., Ltd., Kingsville, Ont. (W) 289.
- Burritt, A. & Co., Mitchell, Ont. (K) 289.
- Burrows, H. H. (Royal Carpet Co.) 288.
- Caldwell, Boyd & Co., Lanark, Ont. (W) 289.
- Caldwell, W. C., Lanark, Ont. (W) 289.
- Canada Hair Cloth Co., St. Catharines, Ont. (W) 291.
- Canada Jute Co., Ltd., Montreal, Que. (D) 293.
- Canada Woolen Mills, Ltd., Toronto and Waterloo, Ont. (W) 291, 292.
- Canadian Carpet Co., Milton, Ont. (W) 289.
- Canadian Colored Cotton Mills Co., Ltd., Montreal, Que., and Cornwall, Ont. (C) 287, 293.
- Canadian Cordage & Mfg. Co., Peterborough, Ont. (F) 290.
- Canadian Hammock Mfg. Co., Paris, Ont. (C) 290.
- Canadian Web Co., Three Rivers, Que. (C) 294.
- Canadian Woolen Mills Co., S. Hyacinthe, Que. (W & K) 294.
- Cargill Rife Mfg. Co., Cargill, Ont. (W) 286.
- Carleton Woolen Co., Woodstock, N. B. (W & K) 283.
- Cartledge, Joseph & Son, Guelph, Ont. (K) 288.
- Cascade Narrow Fabric Co., Coaticook, Que. (C) 293.
- Challand, John & Co., Simcoe, Ont. (W) 291.
- Channel, W. E., St. Catharines, Ont. (K) 291.
- Charlottetown Woolen Mill, Charlottetown, P. E. I. (W) 292.
- Chase, J. R. & Co., Nottawa, Ont. (W) 290.
- Chatham Binder Twine Co., Chatham, Ont. (F) 286.
- Chesley Woolen Mills (J. Grant & Co.) 286.
- Chicoutimi Woolen Mill (Talbot & Girard) 293.
- Childerhose, John & Co. (Eganville Woolen Mills) 287.
- Chipman-Holton Knitting Co., Hamilton, Ont. (K) 288.
- City Woolen Mills, Belleville, Ont. (W) 286.
- Clark, A. & J., Bullock's Corners, Ont. (W) 286.
- Clark, Wm. & Son, West Plamboro, Ont. (W) 292.
- Clark & Co., St. Mary's, Ont. (F) 291.
- Cliff, Lincoln A., Altona, Ont. (K) 285.
- Cluthe, Jacob & Co. (Doon Mills) 287.
- Clutton, S. S., Vienna, Ont. (W & K) 292.
- Clyde Woolen Mills (Caldwell, Boyd & Co.) 289.
- Coaticook Woolen Co., Coaticook, Que. (W) 293.
- Colonial Bleaching & Printing Co., Montreal, Que. (Pr, D, B) 293.
- Colonial Cordage Co., Ltd., St. John's, N. F. (F) 283.
- Consumer's Cordage Co., Ltd., St. John's, N. B., Dartmouth, N. S., Montreal, Que. (J & F) 283, 293.
- Cooper, Mrs. M., Galt, Ont. (W) 287.
- Cornwall and York Mills, St. John, N. B. (C) 283.
- Cornwall Mfg. Co., Ltd., Cornwall, Ont. (W) 287.
- Corscadden, Thos. & Son, Russell, Ont. (W) 291.
- Cortieilli Silk Co., Ltd., St. John's, Que. (S) 294.
- Coupland, George, Creemore, Ont. (W) 287.
- Creelman, James & Sons, Upper St-wiacke, N. S. (W) 285.
- Creemore Woolen Mills (George Coupland) 287.
- Cronkhte Bros., Thessalon, Ont. (W) 291.
- Cumming, James, Lyn, Ont. (W) 289.
- Danford, S. J., Madoc, Ont. (W) 289.
- Delisle, A. & G. T., Yamachiche, Que. (W) 294.
- Denoon, Colin C., Montreal, Que. (K) 293.
- Dickison, Alex., Arkona, Ont. (W) 285.
- Dick, Ridout & Co., Cobourg, Ont. and Winnipeg, Ma. (W) 282, 287.
- Doane, Robert D. (Barrington Woolen Mills) 283.
- Dobson & Co., Cannington, Ont. (W) 286.
- Dodd, John M., Alton, Ont. (K) 285.
- Dominion Bag Co., Ltd., Montreal, Que. (D) 293.
- Dominion Carpet Co., Sherbrooke, Que. (W) 294.
- Dominion Cord & Tassel Co., Montreal, Que. (S) 292.
- Dominion Cotton Mills Co., Ltd., Montreal, Que. (C, B, Pr) 292.
- Dominion Hammock Mfg. Co., Dunnville, Ont. (C) 287.
- Dominion Wadding Co., Ltd., Montreal, Que. (C) 293.
- Dominion Woolen Mfg. Co., Beauharnois, Que. (W) 292.
- Dontigny & Hughson, Arnprior, Ont. (W) 285.
- Doon Mills, Doon, Ont. (W) 287.
- Doon Woolstock Mills, Doon, Ont. (W) 287.
- Douglas, Robert, Cavan, Ont. (W) 286.
- Duffrin Hosiery Co. (N. C. Bollerby & Co.) 291.
- Dufton Sons & Waterhouse, Mitchell, Ont. (W) 289.
- Duffton & Sons, Stratford, Ont. (W) 291.
- Dundalk Woolen Mills Co., Ltd., Dundalk, Ont. (W) 287.
- Dunville Carpet Works (Holt & Kitchen) 287.
- Dyer, James H. & Co., Garden Hill, Ont. (W) 288.
- Eagle Knitting Co., Hamilton, Ont. (K) 288.
- Eastwood, E., Baltimore, Ont. (W) 286.
- Eganville Woolen Mills, Eganville, Ont. (W) 287.
- Elliott, A. & Co., Dunville, Ont. 287.
- Elliott, T. C. & Co., Petersboro, Ont. (K) 290.
- Empire Carpet Co., St. Catharines, Ont. (W) 291.
- Erie Woolen Mills (Slingsby & Waltho) 287.
- Etherington, Elizabeth (Empire Carpet Co.) 291.
- Eureka Woolen Mfg. Co., Ltd., Eureka, N. S. (W) 282.
- Excelsior Knitting Works (J. T. Wood) 290.
- Excelsior Woolen Mills, Montreal, Que. (W) 293.
- Fairall, W. H. & Co., St. John, N. B. (W) 283.
- Farmers' Binder Twine Co., Ltd., Brantford, Ont. (J) 286.
- Ferguson, J. F. (Kingston Cordage Works) 289.
- Field, J. G., Tavistock, Ont. (W) 291.
- Fisher's Woolen Mills, Paisley, Ont. (W) 288.
- Forbes, R., Co., Ltd., Hespeler, Ont. (W & K) 288.
- Forrester, Andrew, Mitchell, Ont. (F) 289.
- Francis & Brazeau, Pakenham, Ont. (W) 290.
- Fraser, Robert S., Montreal, Que. (W) 293.
- Galetta Woolen Mills, Galetta, Ont. (W) 287.
- Galt Carpet Co., Ltd., Galt, Ont. (C) 287.
- Galt Knitting Co., Ltd., Galt, Ont. (K) 287.
- Garayt, H., Montreal, Que. (K) 294.
- Gervais & Bros. (Victoria Hosiery Co.) 294.

- Gibson Cotton Mills, Marysville, N. B. (C) 283.  
 Gillies, A. J. (The Laeces & Braids Mfg. Co.) 292.  
 Gillies Mill, Canada Woolen Mills, Ltd., Carleton Place, Ont. (W) 286.  
 Gilmour Woolen Mill Co., Joliette, Que. (W & K) 293.  
 Gingrich, Noah W., St. Jacobs, Ont. (W) 291.  
 Gledhill, Jessie, Benmiller, Ont. (W) 286.  
 Glendyer Mills (McDonald Bros.) 283.  
 Goderick Knitting Co., Ltd., Goderick, Ont. (K) 288.  
 Golden Fleece Woolen Mills, Almonte, Ont. (W) 285.  
 Golden Grove Woolen Mills (Alex. Willis) 283.  
 Gordon, J. F., Athens, Ont. (W) 285.  
 Graham, D. Sons & Co., Inglewood, Ont. (K) 288.  
 Grant, J. & Co., Chesley, Ont. (W) 286.  
 Grindrod, A. L. & Co., Sherbrooke, Que. (W) 294.  
 Guelph Carpet Mills Co., Guelph, Ont. (W) 288.  
 Gunn & Co., Ailsa Graig, Ont. (F) 283.  
 Gunn & Murray, Strathroy, Ont. (F) 291.  
 Haigh, Geo. & Son, Mt. Albert, Ont. (W & K) 289.  
 Hall, James, Huntsville, Ont. (W) 288.  
 Hall, John (Trenhohnville Woolen Mill) 294.  
 Hamilton Cotton Co., Hamilton, Ont. (C) 288.  
 Hamilton, James & Sons, Stillman, N. S. (W) 285.  
 Hamilton & Ayres, Lachute Mills, Que. (W) 293.  
 Hanover Woolen Mills Co., Ltd., Hanover, Ont. (W) 288.  
 Hanson, Geo. E., Hull, Que. (W & K) 293.  
 Harris & Co., Ltd., Rockwood, Ont. (W) 290.  
 Harrison, Mrs. S., Owen Sound, Ont. (W) 290.  
 Harvey & Hunter, Freilighsburg, Que. (W) 293.  
 Hawthorne Mill (Canada Woolen Mills, Ltd., Carleton Place, Ont. (W) 286.  
 Henev, E. N. & Co. (Montreal Horse Clothing Co.) 294.  
 Hern, John, Orillia, Ont. (W) 290.  
 Hochelaga Cotton Mills (Dominion Cotton Mills Co.), Hochelaga, Que. (C) 293.  
 Hodge, Wm., Cornwall, Ont. (W) 287.  
 Hogg, Geo. & Co., Barrie, Ont. (W) 286.  
 Holt & Kitchen, Dunville, Ont. (W) 287.  
 Homedale Winery Mills (Dominion Cotton Mills Co.) Brantford, Ont. (W) 286.  
 Horn Bros. (Lindsey Woolen Mills) 289.  
 Howarth, Richard, Merriton, Ont. (W & K) 289.  
 Huber, J. T. & Co. (Doon Woolstock Mills) 287.  
 Hudson Bay Knitting Co., Montreal, Que. (W) 294.  
 Humphrey, J. A. & Son, Moncton, N. B. (W) 283.  
 Hutchison, Shurley & Derrett, Toronto, Ont. (F) 291.  
 Huttonville Woolen Mills (J. McMurchy) 288.  
 Imperial Cotton Co., Ltd., Hamilton, Ont. (C) 288.  
 Imperial Knitting Co., Ltd., Dunville, Ont. (K) 287.  
 Imperial Woolen Mfg. Co., Streetsville, Ont. (W) 291.  
 Independent Cordage Co., Toronto, Ont. (F) 291.  
 Jones, Crosland & Co., Toronto, Ont. (W) 292.  
 Kerr Bros., Rocklin, N. S. (W) 285.  
 Kingston Cordage Works, Kingston, Ont. (F) 289.  
 Kingston Branch Dominion Cotton Mills Co., Kingston, Ont. (C) 289.  
 Kingston Hosiery Co., Ltd., Kingston, Ont. (K) 289.  
 Kirkham, A. L., Highland Creek, Ont. (W) 288.  
 Laeces & Braids Mfg. Co., The, Toronto Junction, Ont. (C) 292.  
 Lambton Mills, (Canada Woolen Mills) Lambton Mills, Ont. (W) 289.  
 Landot, J. B. A., Montreal, Que. (K) 294.  
 Laroque, A., Montreal, Que. (K) 294.  
 Lamard, S. & Sons, Dundas, Ont. (K) 287.  
 Levin, A. (Dominion Cord & Tassel Co.) 293.  
 Levis Knitting Co., Levis, Que. (K) 293.  
 Lindsey Woolen Mills, Lindsey, Ont. (W & K) 289.  
 Listowel Woolen Mills, Listowel, Ont. (W & K) 289.  
 Logan Bros., Renfrew, Ont. (W) 290.  
 Lomas, Adam & Son, Sherbrooke, Que. (W) 294.  
 Lossing, Solomon B., Otterville, Ont. (W) 290.  
 Lott, Wm. (City Woolen Mills) 286.  
 Loucks, S. W., Watfords, Ont. (W) 292.  
 McCann Woolen Mill (M. M. McClelland) 288.  
 McCartney, Wm. R., Galt, Ont. (K) 287.  
 McClelland, M. M., Goderick, Ont. (W) 288.  
 McCormack, J. B., Arthur, Ont. (W & K) 285.  
 McDonald Bros., Glendyer, N. S. (W) 283.  
 McDonald, Jas. & Son, Hopewell, N. S. (W) 283.  
 McDonald & Brown, Carleton Place, Ont. (W) 286.  
 McDougall, Peter, Blakeney, Ont. (W) 286.  
 McGowan, John D., Alma, Ont. (F) 285.  
 McKay, M. S. & Co., Galt, Ont. (W) 287.  
 McKay & Co., Orillia, Ont. (W) 290.  
 McKelvie, Sam'l B., Wroxeter, Ont. (W) 292.  
 McKelvie & Hemphill (Mildmay Woolen Mill) 289.  
 McKenzie, E., Kincardine, Ont. (W) 289.  
 MacLaren, Alexander, Wakefield, Que. (W) 294.  
 McLaren, M., Brudenell River, P. E. I. (W) 292.  
 McLean, Hugh, Grand Anse, N. S. (W) 283.  
 McLean, James (Pembroke Woolen Mills) 290.  
 McMurchy, J., Huttonville, Ont. (K) 288.  
 McNally, H., Clemens & Co., Blair, Ont. (W) 286.  
 Magog Cotton Co. (Dominion Cotton Mills Co.) Magog, Que. (Bl. C, Pr) 293.  
 Magog Woolen Mills (A. L. Grindrod & Co.) 294.  
 Main, Alex. & Son, Hamilton, Ont. (C & J) 288.  
 Malcolm, M., Brantford, Ont. (K) 286.  
 Manchester, David, Ottawa, Ont. (W) 290.  
 Manitoba Felt & Yarn Works, Brandon, Ma. (W) 283.  
 Manapan Woolen Mill (James Perry) 289.  
 Maple-Leaf Woolen Mills Co., Toronto, Ont. 289.  
 Matheson, James, Waugh's River, N. S. (W) 285.  
 Mealey, Thos. & Co., Dundas, Ont. (W) 287.  
 Merchants Cotton Co., Montreal, Que. (C) 294.  
 Merchants Dyeing and Finishing Co., Ltd., Toronto, Ont. (D & F) 292.  
 Merner, E. & C. F. (New Hamburg Felt Mfg. Co.) 289.  
 Merriton Knitting Mill, Merriton, Ont. (K) 289.  
 Merriton Mill (Canadian Colored Cotton Mills) Merriton, Ont. (C) 289.  
 Methot, E. & Co., Cape St. Ignace, Que. (W) 293.  
 Meyers, S. & Sons, St. Mary's, Ont. (W) 291.  
 Mildmay Woolen Mills, Mildmay, Ont. (W) 289.  
 Milne, C. S., Don, Ont. (W) 287.  
 Mississippi Woolen Mills, Appleton, Ont. (W) 285.  
 Mitchell, D. & Son, Tamworth, Ont. (W) 291.  
 Mitchell, Wm., Coburg, Ont. (J) 287.  
 Mollur, J. E., St. Johns, Que. (W & K) 291.  
 Moncton Cotton Mills, Moncton, N. B. (C) 283.  
 Montmorency Cotton Mills Co., Montmorency, Que. (C & W) 293.  
 Montmorency Mills (Montmorency Cotton Mills Co.) 293.  
 Montreal Blanket Co., St. Paul, Que. (W) 294.  
 Montreal Cotton Co., Valleyfield, Que. (C) 294.  
 Montreal Fringe & Tassel Works (Moulton & Co.) 294.  
 Montreal Horse Clothing Co., Montreal, Que. (W) 294.  
 Montreal Knitting Co., Montreal, Que. (K) 294.  
 Montreal Woolen Mill Co., Montreal, Que. (W) 294.  
 Moorefield Flax Mill Co., Moorefield, Ont. (F) 289.  
 Morrison Bros., Brownsburg, Que. (W) 292.  
 Morrison, J. B., Hawkesbury, Ont. (W) 288.  
 Morrison, R., Auburn, Ont. (W) 286.  
 Moulton & Co., Montreal, Que. (S) 294.  
 Mount Albert Woolen Mills (Geo. Haigh & Son) 289.  
 Mount Forest Woolen Mills Co., Mount Forest, Ont. (W) 289.  
 Newbold Bros., Montreal, Que. (K) 294.  
 New Hamburg Felt Mfg. Co., New Hamburg, Ont. (W) 289.  
 Newlands & Co., Galt, Ont. (K) 287.  
 Newton Bros. (Sarnia Woolen Mills) 291.



- New Westminster Woolen Mills, New Westminster, B. C. (W) 283.
- Nichol, James, Simcoe, Ont. (K) 291.
- Nova Scotia Mills (Dominion Cotton Mills Co.) Halifax, N. S. (C) 283.
- Odessa Woolen Mills Co., Odessa, Ont. (W) 290.
- O'Hara & Sons, Midland, Ont. (W) 289.
- Ontario Blanket Co (Telfer Bros.) 287.
- Ontario Farmer's Cordage Co., Ltd., Brantford, Ont. (F) 286.
- Ontario Mill (Canadian Colored Cotton Mills Co.) Hamilton, Ont. (C) 288.
- Ottawa Woolen Mills (David Manchester) 290.
- Oxford Mfg. Co., Ltd., Oxford, N. S. (W) 283.
- Palmer, Joseph & Co., Tilsonburgh, Ont. (K) 291.
- Paris Winney Mills Co., The, Paris, Ont. (W) 290.
- Parker, R. & Co., Toronto, Ont. (D & F) 292.
- Parks, W. J., St. John, N. B. (W) 283.
- Patou Mfg. Co., Sherbrooke, Que. (W & K) 294.
- Pattinson & Co., Geo., Preston, Ont. (W) 290.
- Pearcet, F. T. Co., Ltd., Marmora, Ont. (W & K) 289.
- Pembroke Woolen Mills, Pembroke, Ont. (W & K) 290.
- Pennmann Mfg. Co., Ltd., Paris, Ont., Port Dover, Ont., Thorold, Ont., Coaticook, Que. (K) 290, 291, 292.
- Perfection Knitting Co., Ltd., St. Catharines, Ont. (K) 291.
- Perine & Co., Doon, Ont. (J) 287.
- Perry, S. B. Knitting Co., Hamilton, Ont. (K) 288.
- Perry, James, Napanee, Ont. (W & K) 289.
- Perth Flax & Cordage Co., Ltd., Stratford, Ont. (F) 291.
- Perth Woolen Co., Ltd., Perth, Ont. (W) 290.
- Peterborough Underwear Co., Peterboro, Ont. (K) 290.
- Pinder, W., Arthur, Ont. (F) 285.
- Pitts Bros., St. John's, Ont. (W) 291.
- Porter, Leith & Co. (Warton Woolen Mill) 292.
- Purvis, P., Teeswater, Ont. (W) 291.
- Reiner, J. G. (Wellesley Woolen & Knitting Mills) 292.
- Richelieu Woolen Mills (S. T. Willet) 293.
- Ritchie, F. J., Markdale, Ont. (W) 289.
- Riverside Mill (Montmorency Cotton Mills Co.) 293.
- Robert, J. B., Beauharnois, Que. (W) 292.
- Robinson & Henderson, Blyth, Ont. (W) 286.
- Rosmond Woolen Co., Almonte, Ont. (W) 285.
- Ross, J. Wesley, Margaree, N. S. (W & K) 283.
- Royal Carpet Co., Guelph, Ont. (W) 288.
- Royal Knitting Co., Guelph, Ont. (K) 288.
- Rumpel, Geo. (Berlin Felt Boot Co.) 286.
- Ryem, John (Western Woolen Mills) 283.
- Sarnia Woolen Mills, Sarnia, Ont. (W) 291.
- Scantlion, Frank, Almonte, Ont. (W) 285.
- Schofield Woolen Co., Ltd., Ashawa, Ont. (K) 290.
- Scott, M. E. & Co., Toronto, Ont. (K) 292.
- Sebringville Flax Co., Ltd., Sebringville, Ont. (F) 291.
- Sharp & Bowerman (Bloomfield Woolen Mills) 286.
- Shea, Wm., Toronto, Ont. (K) 292.
- Sills & Bros., Frankford, Ont. (W) 287.
- Simcoe Wool Stock Co., Simcoe, Ont. (W) 291.
- Simpson, Joseph & Sons, Toronto, Ont. (K) 292.
- Slingsby Mfg. Co., Ltd., Brantford, Ont. (W) 286.
- Slingsby & Waltho, Dunville, Ont. (W) 287.
- Smith Wool Stock Co., Toronto, Ont. (W) 292.
- Speedville Woolen Mills (D. Vickerman & Son) 290.
- Stag Dominion Hair Cloth Factory, St. Catharines, Ont. (C) 291.
- Standard Woolen Mills Co., Toronto, Ont. (W & K) 292.
- Star Quilting & Hosiery Co., Montreal, Que. (K) 294.
- St. Croix Cotton Mill, Milltown, N. B. (C) 283.
- St. Croix Woolen Mfg. Co., Ltd., St. Croix, N. S. (W) 285.
- Stormount Mill (Canadian Colored Cotton Mills Co.) Cornwall, Ont. (C) 287.
- Stratford Woolen Mills (Duffon & Sons) 291.
- Strathroy Woolen Mills, Strathroy, Ont. (W) 291.
- Sykes & Ainley Mfg. Co., Ltd., Glen Williams, Ont. (W) 288.
- Talbot & Girard, Chicoutimi, Que. (W) 293.
- Tara Woolen Mill, Tara, Ont. (W) 291.
- Taylor, T. H. & Co., Ltd., Chatham, Ont. (W & K) 286.
- Telfer Bros., Clarksburg, Ont. (W) 287.
- Teskey, J. Adam (Mississippi Woolen Mills) 285.
- Thessalon Woolen Mills (Cronkhite Bros.) 291.
- Thoburn, Wm., Almonte, Ont. (W) 285.
- Toronto Carpet Mfg. Co., Ltd., Toronto, Ont. (W) 292.
- Trenholmvile Woolen Mill, Trenholmvile, Que. (W & K) 294.
- Trent Valley Woolen Mfg. Co., Ltd., Campellford, Ont. (W) 286.
- Truro Knitting Mills Co., Ltd., Truro, N. S. (K) 285.
- Tryon Woolen Mfg. Co., Tryon, P. E. I. (W) 292.
- Turnbull, C., Co., Ltd., Gail, Ont. (K) 287.
- Universal Knitting Machine Co., Ltd., Toronto, Ont. (K) 292.
- Upton, Geo., Alliston, Ont. (W & K) 285.
- Ure, James A., Maberly, Ont. (W) 289.
- Valley Woolen Mill Co., Southampton, N. S. (W) 285.
- Van Edmond, W. D., Seaforth, Ont. (W) 291.
- Vickerman, D. & Son, Preston, Ont. (W) 290.
- Victoria Hosiery Co., St. Johns, Que. (K) 294.
- Voigh & Rosenow, Wildmay, Ont. (F) 289.
- Walkerton Binder-Twine Co., Ltd., Walkerton, Ont. (F) 292.
- Wallace, John, Hosiery Co., Beeton, Ont. (K) 286.
- Walshaw, J. (Bolton Woolen Mills) 286.
- Warren Bros., St. Catharines, Ont. (K) 291.
- Warren, Thos., Toronto, Ont. (K) 292.
- Ward, G. W., Alton, Ont. (W & K) 285.
- Warner, E. & Son, Aliviston, Ont. (W) 285.
- Watchorn & Co., Merrickville, Ont. (W) 289.
- Waterhouse & Bradbury, Ignersoll, Ont. (W) 288.
- Waterloo Knitting Mills, Waterloo, Que. (K) 294.
- Watson Mfg. Co., Paris, Ont. (K) 290.
- Watts, W. J., Drummondville, Que. (W) 292.
- Weir & Weir, St. Mary's, Ont. (F) 291.
- Wellesley Woolen and Knitting Mills, Wellesley, Ont. (W & K) 292.
- Western Woolen Mills, St. Boniface, Ma. (W & K) 283.
- Westport Woolen Mills Co., Westport, Ont. (W) 292.
- White-Ailen & Co., Toronto, Ont. (F) 292.
- White, Galetta (Galetta Woolen Mills) 287.
- Warton Woolen Mill, Warton, Ont. (W) 292.
- Willet, S. T., Chambly Canton, Que. (W) 293.
- Williams, Hurlbert Co., Ltd., Collingwood, Ont. (K) 287.
- Willis, Alex., Golden Grove, N. B. (W) 283.
- Windsor Branch (Dominion Cotton Mills Co.) Windsor, N. S. (C) 285.
- Winger Woolen & Felt Co., Ltd., Elmira, Ont. (W) 287.
- Winnipeg Bag Works (Dick, Ridout & Co.) 283.
- Wood, J. T., Rockwood, Ont. (K) 290.
- Woolen, Thos., Guelph, Ont. (K) 288.
- Wylie, James H., Almonte, Ont. (W) 285.
- Wylie & Shaw (Almonte Blanket Co.) 285.
- Yarmouth Duck & Yarn Co., Ltd., Yarmouth, N. S. (C) 285.
- Young, C. T., Beavertown, Ont. (W) 286.
- Young, James M. (Hamilton Cotton Co.) 288.
- Young, J. & G. H. & Co., Montreal, Que. (K) 294.

## TOO LATE FOR CLASSIFICATION IN MILL SECTION.

HED—Too late for classification .....

—Alabama, Pell City. Pell City (C Mfg. Co.; C. E. Riley, W. R. Sears (Boston, G. W. Pratt, S. Cogswell, J. D. Cloudman, interested. Proposed.

—Alabama, Piedmont. Coosa Mfg. (C Co.; Yarns, average number about 50s; 0,050 spindles. (New mill to be built. May turn it over to new company.)

—Alabama, Stevenson. Broadus (C Cotton Mills; \$50,000; S. S. Broadus, pres. and treas.; H. C. Ray, gen. mgr.; Yarns, 8s to 16s; 2500 ring spindles; steam. (Full report of item on page 70.)

—Connecticut, Danielson. Danielson (W Worsted Co., The; \$15,000; John R. Davis, pres.; Cassius S. Chase, treas.; Frank Casey, supt.; Worsted Goods; 10 looms, steam; Cassius S. Chase, buyer.

—Connecticut, Jewett City. (Pr.D.&Bl.) Aspinook Co.; \$500,000; Edward Harland, pres.; L. H. Cunliff, vice-pres.; O. L. Johnson, Jr., treas. and mgr.; Print, Bleach and Dye Cotton Fabrics; steam and water; O. L. Johnson, Jr., buyer. (Correction of report on page 75.)

—Connecticut, Lyme. Bradbury, J. (W H. & Co., Wool Scourers.

—Connecticut, Norwich. Fenner, J. K (Rochdale, Mass.); Blissville Mill; Dye Yarns and Men's Half Hose; 1 set cards; Proposed. (See page 130.)

—Connecticut, Sand Hook. Sandy (W Hook Woolen Co. Removed from town; address unknown. See report on page 79.

—Connecticut, Stamford. Stamford (W Worsted Mills; John W. Nary and Arthur Schwarz; Fine Worsteds; 100 looms; steam; dye; sell direct.

—Connecticut, Torrington. Belfast (K Mesh Underwear Co.; \$80,000; W. H. Dayton, pres.; Geo. W. Greene, treas., agt and buyer; Linen Underwear. (Propose starting in fall 1902.)

—Georgia, Barnesville. Barnes (C & D ville Mfg. Co.; \$135,000; (to be increased to \$200,000); J. P. Thurman, pres.; Merritt Thurman, treas.; J. D. Hough, agt.; Cotton Yarns, 6s to 24s; 9760 spindles; steam; dye (not in operation at present); sell direct. (Re-organization of Barnesville Mfg. Co.) (See also page 86.)

—Georgia, Cedartown. Cherokee (K Knitting Mill; \$10,000; H. F. B. Booth, gen. mgr.; Men's Underwear; use 6 to 7 yarns

in Peeler and Egyptian; 12 cylinders; 35 sewing machines; sell direct and J. P. Graff & Co., N. Y., s. agts.

—Georgia, Lawrenceville. Lawrence (C ville Mfg. Co.; \$100,000; A. E. McDonald, agt. and buyer; White Hosiery Yarns, from 5s to 20s; 4,200 mule spindles; steam; sell direct.

—Georgia, Lindale. Massachusetts (C Mills in Georgia; \$2,000,000; Standard Sheetings and Drills; 42,000 ring spindles; 1,262 looms. (New mill. Expect to start up Jan., 1903.)

—Illinois, Chicago. Standard Mantle (K Knitting Co.; \$2,500; Mrs. Hattie Bloch, pres.; J. Bloch, treas.; Hoods for Incandescent Gas Mantles; 24 knitting machines; steam; sell direct. (Corrected report; see page 95.)

—Kentucky, Louisville. Eclipse (W Woolen Mills; \$150,000; D. A. Chenoweth, pres.; John P. Chenoweth, sec. and treas.; Cassimeres and Jeans.

—Maine, Lee. Gifford, J. T. & (W Sons. Mill burned March, 1902; not known if ever rebuilt.

—Massachusetts, Charlton City. Al- (W drich Mfg. Co.; \$6,000; Chas. A. Hill, pres.; L. B. Butler, treas.; Thomas Heap, supt.; Satinets; 2 sets; 30 looms; steam and water; L. B. Butler, buyer. (Make goods for another company.) See also page 113.

—Massachusetts, Chicopee. Ashworth, (K James T. (Lock Box 1,111); Knit Goods, Noelties and Turf Goods; uses cotton, wool and mercerized cotton yarns.

### Mechling Bros. Mfg. Co.,

LINE AND PINE STS., COOPER'S CREEK,

Camden, N. J.

MANUFACTURERS AND GRINDERS OF

Sal Soda, Ammoniated Soda and  
Potash, Caustic Soda, all Tests.

*Special attention is called  
to our Powdered 98%  
Caustic Soda for Mercer-  
izing.*

**R. R. STREET & CO., CHICAGO.**

HEADQUARTERS FOR

**Everything for Textile Mills**

INCLUDING

**Machinery, Supplies, Dyestuffs, Chemicals and Power Plants.**

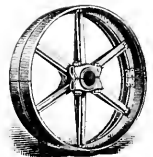

—Massachusetts, Easthampton. West (C Boylston Mfg. Co.; \$600,000; J. W. Lane, pres.; H. F. Harris, treas.; E. E. Childs, asst. treas.; Geo. A. Ayer, supt.; Cotton Goods; 42,000 spindles; 800 looms; steam; J. H. Lane & Co., N. Y., s. agts. (Corrected report of mill on page 115.)

—Massachusetts, Millbury. Holbrook (C Mfg. Co.; \$30,000; F. H. Rice, pres.; E. C. Willey, treas.; E. F. Rice, supt.); 50 looms.

—Massachusetts, New Bedford. But- (C ler Mills; \$700,000; Wm. M. Butler, pres.; Fine Lenos, Dimities, Lawns, etc.; 100,000 spindles; 2,000 looms; steam and electricity. (Under construction.)

—Massachusetts, Newton. Nonantum (W Worsted Co.; Geo. F. Hall; John Healy, supt.; Worsted Yarns; (Bradford system); 2,000 spindles. Correction report on page 126.

—Massachusetts, South Attleboro. (C Orr, Chas. F.; Shoe Laces; steam; dye; sells direct. (Plant at Mansfield; to be located here after Aug. 1.) (See page 124.)

—Massachusetts, Spencer. Leavitt & (W Goldberg; H. C. Leavitt, agt.; Satinets; 3 sets; 24 looms; steam and water; dye; Lane & Barrows, s. agts.; H. C. Leavitt, buyer. (Correction of report on page 131.)

—Massachusetts, Spencer. Taylor. (W Simon; Thos. F. Cregan, supt.; Medium Fancy Cassimeres; 3 sets; 17 looms; steam and water; dye; commission work for Beebe, Webber & Co. (Operating mill previously run by Beebe, Webber & Co.)

—Massachusetts, Walpole. Lewis, (C James B.; Cotton Waste.

—Massachusetts, Webster. Merritt (W Woolen Co.; \$50,000; Henry Merritt and others; Worsteds.

—Massachusetts, Worcester. New (W England Dusting Mill; I. Goldberg & Co., props.; 4 Grafton St.; Dusting, Burring, Dyeing and Carbonizing; steam; I. Goldberg, buyer.

—Massachusetts, Worcester. Worcester (C ter Thread Co. Purchased by Linen Thread Co., N. Y.

—Michigan, Pontiac. Pontiac Knit- (K ting Co.; \$50,000; E. R. Webster, pres.; F. G. Jacobs, treas.; J. D. Partello, supt.; Mittens, Hosiery, Jackets, Gloves, etc.; 4 sets; 150 knitting machines; steam and water; dye; sell direct. (Purchased plant of Pontiac Knitting Works Co.)

—Mississippi, Aberdeen. Aberdeen (C Cotton Mills; \$250,000; W. M. Stokes, treas.; probably Coarse Sheeting; 10,000 spindles; 350 looms; steam. (Start construction about August. Expect to begin running September, 1903.)

—Mississippi, Enterprise. Wanita (W Mills; \$10,000; C. A. Lyerly, pres.; F. H. Shults, treas.; Woolen Yarns, Batts and Wool Rolls; (also custom work); 1 set; 2 looms; water; dye; sell direct. Mill damaged by flood and machinery mostly taken out and sold.) (See report on page 140.)

—Mississippi, Magnolia. Mag- (C nolia Cotton Mills; \$100,000; L. L. Lampton, pres.; T. B. Lampton, treas.; S. R. Stevens, supt.; 5.5 yd. Sheetings; Yarns from 20s to 30s; 5,000 ring spindles; 160 looms. (Under construction.)

—New Jersey, Camden. Hodgson (W Bros.; Worsted Yarns; (spin on commission); 2 combs (Bradford system); 2 worsted cards; 2,000 worsted spindles; steam and water; sell direct. (After Aug. 1 plant will be located at Wilmington, Del.) (See also page 148.)

—New Jersey, Paterson. Degener, (S A. and R. J. Steiner; Hope Mill; Silks.

—New Jersey, Paterson. Paterson (S Silk Textile Institute; (instruction purposes); \$3,000; W. F. Childs, sec.; all kinds Silks; dye.

—New Jersey, West New York. (S Palisade Silk Co.; \$100,000; O. DeForest, pres.; W. H. DeForest, treas.; John Nightingale, supt.; Silk Piece Goods; 322 looms; steam; sell direct; O. DeForest, buyer. (Dye house to be built.)

—New Jersey, Wortendyke. Granite (L Linen Company, Granite Mills; Frank Woodhead, mgr. Removed from Paterson, N. J. (See report on page 155.)

—New York, Brooklyn. Empire (K Knitting Mills, 40 Meserole St.

—New York, Brooklyn. Johns Man- (A ville Co., H. W. (100 William St., N. Y.); Asbestos Cloths, Theatre Curtains, Fire-proof Rope, etc.; 7 sets woolen cards; 10 looms. (Mill at South Brooklyn.)

—New York, Deposit. Leonard Mill; (S August A. Fischer, sec. and mgr.; Silks. (Branch of Caspers Silk Co., Paterson, N. J.)

—New York, Dryden. Elmira Blan- (W ket Mill; (office at Elmira); N. D. Doxey, sec. and treas.; D. R. Davenport, mgr.; Blankets, Piano Felts and Shoddy; steam; dye. (See also report on page 168.)

—New York, Fort Plain. Fort (K Plain Hosiery Co.; Schoen & Abeel; Men's Medium Half Hose.

—New York, Prospect. France. (K David; Sweaters and Specialties. Proposed.

—New York, Utica. Otter Knitting (K Co.; L. A. Lincoln, pres.; F. S. Baker, sec. and treas.; Ladies' Underwear; 27 machines.

—North Carolina, Durham. Erwin (C Cotton Mills Co., The. To build No. 2 mill; 35,000 spindles, 1000 looms for denims. (See also page 188.)

—North Carolina, Oxford. Shaw. H. (K M.; interested in knitting mill. Proposed.

—North Carolina, Salisbury. Kesler (C Mfg. Co.; increased capital stock to \$175,000 to install 200 looms. Probably make Sheeting. (See also page 194.)

—Pennsylvania, Collegeville. Per- (K kiomen Knitting Mills; (copartnership William Todd, Jr., and Herbert C. Spooner); Men's and Women's Hosiery; 37 knitting machines. (Start July 1, 1902.)

—Pennsylvania, Philadelphia. Octo- (F raro Linen Finishing Company; Finish Table Linen, Towels, Crashes, etc. (Operating plant of Taylor & Scott.)

—Pennsylvania, Reading. (D, B1 & Pr Sanitary Dyeing Co.; Paul Rothe, pres.; T. H. Morgan, treas.; Christoph Eilsfeld, supt.; Dye, Bleach, Print and Extract for the Trade, Cotton and Mercerized Hosiery (Specialty Fast and Sanitary Fast Black and Colors with Lisle or Silk Finish); steam.

—Pennsylvania, Siverly. Edwards (W Woolen Co.; \$60,000; James P. Edwards, pres.; Wm. Edwards, Jr., treas.; Fine All Wool Yarns and Bed Blankets; 2 sets; 1080 woolen spindles; 18 looms; steam; dye; sell direct; J. P. Edwards, buyer; increased machinery; (after Aug. 15 will operate plant now at Spartansburg at this place). See page 248.

—Pennsylvania, Tub. Bender, Val.; (W Woolen Goods, Yarns, etc.; 1 set; 2 looms; steam; dye; sell direct .

—Rhode Island, Providence. Cooper (D Mercerizing Company, 110 West Exchange St.; Mercerizing for the trade.

—Rhode Island, Providence. (C & S Whiting Narrow Fabric Co.; John C. Whiting, prop., 143 Summer St.; Plain and Fancy Tapes, Cotton and Silk; sell direct. (Corrected report of mill on page 255.)

—South Carolina, Anderson. Bro- (C gon Cotton Mills; \$500,000; J. A. Brock, pres.; Robt. E. Ligon, treas.; R. L. Cum- nock, supt.; 20,000 spindles; 700 looms; steam; dye; Woodward, Baldwin & Co., N. Y. and Balto., s. agts.; Robt. E. Ligon, buyer. (Expect to start Jan. 1, 1903.)

—South Carolina, Easley. Glenwood (C Cotton Mills; \$250,000; W. M. Hagood, pres. and treas.; 84 by 84 Fine Sheetings; 16,520 ring spindles; 412 looms; steam; Woodward, Baldwin & Co. to be s. agts. (Under construction.)

—South Carolina, Honeapath. Chi- (C quola Mfg. Co.; \$200,000; Jas. D. Ham- mett, pres. and treas.; 40-inch Cloths for Converting Trade; 11,280 ring spindles; 300 looms; steam; Woodward, Baldwin & Co., N. Y., s. agts.; Jas. D. Hammett, buyer. (Expect to start Jan., 1903.) (Also mentioned on page 265.)

—Utah, Fairview. Peterson, Peter (K R. & Co.

—Utah, Salt Lake City. Weston (K Knitting Co.; \$50,000; Jos. A. West, pres. and supt.; Joel Ricks, treas.; All Kinds Knit Underwear; 16 knitting machines; sell direct; Joel Ricks, buyer. (Absorbed Ogden Knitting Factory, Ogden, and Provo Knitting Factory, Provo.)

—Virginia, Emporia. Hall, H. W. (K Half Hose. Proposed.

—Wisconsin, Menasha. Fox River (K Valley Knitting Co.; \$50,000; C. Madson, pres.; D. Nottage, treas.; J. Steinborg, supt.; Men's Woolen Hosiery, Lumber- men's Socks, Mitts; 4 sets; 75 knitting machines; steam and water; dye; sell direct. (Plant at Appleton burned; re- moved here.) (See also page 280.)

# WHILE YOU TRAVEL.

**If YOU ARE** selling to textile mills you spend many hours on the trains. Why not inform yourself thoroughly in your spare time on textile manufacturing, so that you can talk more intelligently to mill treasurers, agents and superintendents? You will sell more because you will get a better insight into their work, and will consequently become more valuable to your employers. You can gain much valuable information on

## Preparatory Work in Wool and Cotton.

Woolen and Worsted Spinning.  
Cotton Spinning.

Wool and Cotton Warp Preparation.  
Cam, Dobby and Jacquard  
Looms.

Woolen and Worsted Finishing.  
Textile Chemistry  
and Dyeing.

Courses prepared by Textile Experts.  
Instruction by mail under practical  
men.

## Textile Inquiries.

Students of the American School are entitled to answers to inquiries based upon the studies on which they are engaged and upon their daily work, inasmuch as it applies to these.

We make a nominal charge for answering inquiries outside of these bounds, and also to those who are not enrolled as students.

Write to us about designs, chain drafts, drawing drafts, formulas, and for expert advice.

**A limited number of Free Scholarships will be awarded to properly recommended men.**

*The only Correspondence School whose Examination Credits are accepted by a resident school.*

Large illustrated handbook and full particulars on application.

**American School of Correspondence,**  
*(Chartered by Commonwealth of Mass.)*  
**BOSTON, MASS., U. S. A.**

# MILLS WITH WORSTED MACHINERY.

X means Comb and Spin; T means Tops; S means Drawing and Spinning only; C means Carpet Yarns; F means French System.

## CONNECTICUT.

Meriden, Rawitser & Bro. (X)  
Moosup, Moosup Mills, Am. Woolen Co. (X)  
Poquonock Health Underwear Co. (X F)  
Seymour, Tingue Mfg. Co. (X)  
Stafford Springs, Stafford Worsted Co. (X)  
Thompsonville, the Hartford Carpet Corp. (X C)

## DELAWARE.

Henry Clay Factory, Hodgson Bros. (S)

## ILLINOIS.

Fairfield, Fairfield Woolen Mills. (S)  
Rockford, Rockford Mitten & Hosiery Co. (X F)

## KENTUCKY.

Louisville, Hope Worsted Mills. (X)

## MAINE.

Sanford, Goodall Worsted Co. (X)  
Sanford, Sanford Mills. (X)  
Springvale, Maine Alpaca Co. (X)

## MASSACHUSETTS.

Auburn, Hogg, Wm. Jas. & Co. (C X)  
Bemis, Bemis Mill. (X)  
Clinton.  
Bigelow Carpet Co. (X C)  
Clinton Worsted Co. (X)  
Fitchburg.  
Star Worsted Co. (X)  
Gilbertville, see Ware.  
Globe Village, Hamilton Woolen Co. (X)  
Graniteville, Abbott Worsted Co. (X C)  
Also at Forge Village.  
Holyoke, Farr Alpaca Co. (X)  
Hudson, Hudson Worsted Co. (T)  
Lawrence.  
Arlington Mills. (X T F)  
Brown & Whittier. (S)  
Butler, Frederick. (T)  
Crescent Worsted Co. (S)  
Globe Worsted Mills (American Woolen Co.), Allen St. (X)  
Pacific Mills. (X F)  
Prospect Worsted Mills (American Woolen Co.) (S)  
Washington Mills, Am. Woolen Co. (X F)

## Lowell.

Bigelow Carpet Co., Lowell Mills. (X C)  
Massachusetts Mohair Plush Co. (X)  
New England Bunting Co. (X)  
United States Bunting Co. (X)  
Walsh Wm. E. (S)

## Newton.

Nonantum Worsted Co. (S)  
Saxony Worsted Mills. (F)

North Chelmsford, Moore, George C. (X C T)

Pittsfield, Tillotson, Wm. E. (X)  
Saxonville, Saxonville Mill. (X C)  
Ware, Gilbert, Geo. H. Mfg. Co. (X)  
Also at Gilbertville.

Westford, Moore, George C. (X C)

## Worcester.

Queensbury Mills. (X)  
Worcester Carpet Mill. Whittall, M. J. (X C)

Whittall & Thomas, Edgeworth Mill. (X C)

## NEW HAMPSHIRE.

Manchester, Manchester Mills. (X F)

## North Salem.

Rockingham Mills. (S)

Wilton, Hillsborough Mills. (X C)

## NEW JERSEY.

Bloomfield, Oakes, Thomas & Co. (X)  
Bordentown, Springfield Worsted Mills. (X)

## Camden.

Boyer, B. F. & Co. (X F)  
Highland Worsted Mills. (X)  
Linden Worsted Mills (Howland Croft, Sons & Co.) (X)

Philadelphia Worsted Co. (X)  
Shimer, George & Son. (X)

Changewater, Skerry, A. T. & Co., Hopatcong Worsted Mills. (X).

Little Falls, Beattie Mfg. Co. (X C)

## Passaic.

Botany Worsted Mills. (X F)  
Passaic Worsted Mills (The Pitkin, Holdsworth Worsted Co.) (X)  
Robertsford Worsted Mills, S. Hird. (X)

Trenton, Trenton Worsted Mills. (X)  
Sold at auction to A. H. Ryan, Sommerville, N. J.

## NEW YORK.

Amsterdam, Sanford, Stephen, & Sons. (X C)

Auburn, Nye & Wait Carpet Co. (X C)

Brooklyn, Perkins, J. T. Co., Hooper St. (X)

Falconer, Falconer Worsted Mills. (X)

Fulton, Fulton Worsted Mills, American Woolen Co. (X F)

## Jamestown.

Broadhead Worsted Mills (Wm. Broadhead & Sons). (X)  
Chatauqua Worsted Mills. (X T)  
Empire Worsted Mills. (X)  
Jamestown Worsted Mills, Hall & Co. (X)

Montgomery, Crabtree & Patchett. (X)

Newburgh, Crabtree & Patchett. (S)  
 New York.  
 The Pitkin, Holdsworth Worsted Co.  
 (Manhattan Worsted Co.) X  
 Rifton Glen, Dimick, J. W. Co. (X C)  
 Utica, Globe Woolen Co. (X)  
 West Cornwall, Firth Carpet Co. (X C)  
 Watervliet, Roy, Jas. & Co. (X)  
 Yonkers, Smith, Alexander, & Sons Car-  
 pet Co. (X C)

## OHIO.

Cleveland Cleveland Worsted Mills Co.  
 (formerly Turner Worsted Co.).  
 (X)

## OREGON.

Salem, Kay, Thos., Woolen Co. (X)

## PENNSYLVANIA.

Philadelphia.  
 Abbot Mfg. Co., Hancock and Somers-  
 set Sts. (X)  
 Ball, H. C. & Co., Manayunk. (X)  
 Bradford Mills, Germantown. (X)  
 Bromley Bros.' Carpet Co., York and  
 Jasper Sts. (X C)  
 Caledonia Worsted Mill (Alexander  
 Crow. (X C)  
 Cameron, A. J. & Co., American and  
 Dauphin Sts. (T)  
 Cameron, A. J. Worsted Co., Emerald  
 and Westmorland Sts. (S)  
 Dearnley, John H., 8th and Somerset  
 Sts. (X).  
 Doak, James, Jr. & Co., Trenton Ave.,  
 Norris & Blair Sts. (X)  
 Dobson, J. & J., Falls of Schuylkill  
 Carpet Mills. (X C)  
 Erben, Harding & Co., 2416 Spring  
 Garden St. (X F)  
 Fleischer, S. B. & B. W., 25th and  
 Hamilton Sts. (X)  
 Folwell Bros. & Co., 3rd and Cambria  
 Sts. (X)  
 Griswold Worsted Co., Ltd., 326 Chest-  
 nut St. (X) See Darby.  
 Herbst, Albert & Co., Allegheny Ave.  
 and Emerald St. (S)  
 Imperial Woolen Co., Manayunk. (X)  
 Kennebec Worsted Co., Ltd., 2032 Nau-  
 dain St. (X)  
 Kentworthy, T. & Bro., Manayunk.  
 (XC)  
 Lupton, Oliver & Co., No. Manayunk,  
 Pa. (X)  
 Mt. Vernon Worsted Mills (Dobson, J.  
 & J.), Manayunk. (X)  
 Phoenix Mills Co., Cotton St., Man-  
 ayunk. (X) Not running. Re-  
 ported to be sold May, '02.  
 Roosevelt Worsted Mills. (X)  
 Scholes, Wm. & Son, 2nd and Cambria  
 Sts. (X C)  
 Southwark Mills Co., Continental  
 Mills. (XF)  
 Tracy Worsted Mills Co., 2500 Spruce  
 St. (X)  
 Waverly Worsted Co., Main St., Man-  
 ayunk. (S)  
 Wayne Junction Spinning Co., Wayne  
 Junction. (X)  
 Wolstenholme & Clark, Baker and  
 Mellory Sts., Manayunk. (X F)  
 Wels'enholme, Thos. Sons & Co. (X F)  
 Yewdall & Jones Bros., 5th and Wy-  
 alusing Ave. (X)

Bloomsburg, Magee Carpet Works. (X C)

Bridgeport, Lees, James, Sons Co. (X C)  
 Bristol.  
 Grundy, W. H. & Co. (X)  
 Steel, Edward T. & Co. (X)  
 Chester.  
 Eminott Chester Worsted Spinning  
 Co. (X)  
 Strauss, F. A. & Co. (X)  
 Clifton Heights.  
 Thos. Kent. Mfg. Co. (Runnymede  
 Mills). (S F)  
 Crum Lynne, Longbottom, S. & Sons.  
 (X)  
 Darby, Griswold Worsted Co., Ltd. (X)  
 Doylestown, Aveyard, Wm. & Co. (S)  
 Landenburg, Lund, Ezra. (X)  
 Millville, Enterprise Worsted Co. (X)  
 Shickshinny; Shickshinny Worsted Mills.  
 (S)  
 Sunbury, Sunbury Worsted Spinning Co.  
 (S)  
 Tunkhannock; Winola Worsted Yarn Co.  
 (X)  
 Wallingford, Columbia Worsted Co. (X)  
 West Conshohocken, Merion Worsted Co.  
 (X F)

## RHODE ISLAND.

Bristol, Cranston Worsted Mills. (X)  
 Centredale, Centredale Worsted Mills.  
 (X)  
 Lymanville, Lymanville Co. (X)  
 Olneyville, British Hosiery Co. (X)  
 Pawtucket.  
 Goff, D. & Sons. (X)  
 Lorraine Mfg. Co. (X)  
 Peacedale, Peacedale Mfg. Co. (X)  
 Providence.  
 Atlantic Mills. (X F)  
 Crown Worsted Mills. (S)  
 National & Providence Worsted Mills.  
 American Woolen Co. (X F)  
 Regal Worsted Mills. (X)  
 Riverside Mills, Am. Woolen Co. (X)  
 Steere Worsted Mills. (X)  
 Valley Mills, Am. Woolen Co. (X)  
 Wanskuck Co. (X)  
 Weybosset Mills, Am. Woolen Co. (X)  
 Stillwater, Centredale Worsted Mill. (X)  
 Thornton.  
 Pocasset Worsted Co. (S)  
 Victoria Mills. (T)  
 Woonsocket.  
 Lafayette Worsted Co. (X F)  
 Woonsocket Worsted Mills. (X)  
 Loridan Worsted Mills. (X F)

## TEXAS.

Houston Heights, Oriental Textile Mills.  
 (X)

## UTAH.

Provo City.  
 Provo City Woolen Mills Co. (X)

## WISCONSIN.

Cedarburg, Cedarburg Woolen Mills. (X)  
 Milwaukee, Milwaukee Worsted Mills.  
 (X)

# JOHN J. HAYES & CO.,

47 NORTH FRONT ST., PHILADELPHIA,

**WOOL,  
NOILS,  
WASTES,**

Make a specialty of buying Worsted Mill Waste Products, such as Noils, Threads, Sorts, Shorts and Card Waste. Mohair, Camel's Hair, Garnetted Waste, Scoured Shorts, Scoured Wools. Are interested in anything that a Mill has to sell, such as Off Lots or Odd Lots, Yarns, Mill Waste, etc., for cash. Send samples or write when you have anything to sell.

## IMPORTANT IMPROVEMENT IN WORSTED SPINNING.

The Bamford Dust Proof and Self-Lubricating Spindle Tube saves oil, prevents clogging with dust and lint, thereby insuring longer life to the tubes, saves labor, maintains uniform speed, and **most important of all, makes PERFECT YARN.** Refer to largest worsted mills.

**BAMFORD & SMITH, Pascoag, R. I.**

ALSO MFRS. OF

**STEEL CAPS AND SPINDLES.**

**CAPS, FLYERS, TUBES, Etc. REPAIRED.**

ESTABLISHED 1842

# THE E. HOWARD CLOCK CO.

MAKERS OF

## TOWER CLOCKS

WATCHMAN'S CLOCKS  
OFFICE CLOCKS  
BANK CLOCKS

LIBRARY CLOCKS  
SCHOOL CLOCKS  
ASTRONOMICAL CLOCKS  
RAILROAD CLOCKS

CHURCH CLOCKS  
HALL CLOCKS  
MARINE CLOCKS

CLOCKS OF SPECIAL DESIGN AND ALSO THE FAMOUS

"E. HOWARD & CO. WATCHES"

**BOSTON OFFICE, 403 WASHINGTON STREET**

FACTORY, 206 Eustis St. (Roxbury Dist., Boston) **NEW YORK OFFICE, 41 Maiden Lane**

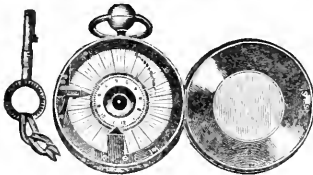

**RIGGS & BROTHER,**

Send for Catalogue & Prices. 310 Market St., Phila., Pa.

Watchman's Clocks, Electric <sup>AND</sup> Portable;  
ENGINE ROOM AND FACTORY CLOCKS;  
TIME AND DATING STAMPS.

ELECTRIC  
TORCHES.

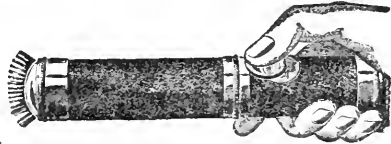

# Newman Clock Co.,

501 MASONIC TEMPLE, CHICAGO,

Manufacturers and Importers of all kinds of Stationary,  
Electrical and Portable

## Watchmen's Clocks

WITH ALL THE LATEST IMPROVEMENTS.

AND

Dealer in All Kinds of Watchman Clock Dials and Supplies.

Send for Circular T, describing our 16 Station Outfit for \$50.00, the latest thing in Watchmans Clocks.

WHEN ORDERING DIALS, SEND SAMPLE.



*Over 6000 now in use  
in the Cotton Mills  
of the United  
States. No  
greater argu-  
ment is  
needed to  
prove its  
value.*



**THE BARBER KNOTTER**

It  
saves  
in the  
spooling,  
in the  
warping,  
and in the  
weaving.



**Barber & Colman,**

11 Pemberton Square,  
BOSTON, MASS.

**ROBERT C. WEBSTER,**  
MANAGER.



# The Yarn Trade Index.

In this department will be found classified lists of manufacturers of different kinds of yarn who sell their product. So far as possible the sizes of yarn which are made are given and the form in which the yarn is put up, together with the selling agents of the mills. Dealers and commission merchants are not included in these lists. There is a separate list following the list of yarn manufacturers in which are included such firms.

The publishers shall be pleased to receive a notice of any corrections that should be made. Owing to lack of space, all mills are not included under every heading under which they should appear. So far as possible they have been listed under the heading which is their principal line of business, or for which they have expressed a preference.

If any kinds of yarn are wanted which are not found in these classified lists, the publishers can probably supply the addresses of manufacturers or dealers from which they may be obtained.

## COTTON KNITTING YARNS.

### Carded Mule Spun American Peeler and Egyptian.

Alden Knitting Mills, New Orleans, La. 12s to 20s; cones, tubes, cops. Sell direct.

Cedartown Cotton Co., Cedartown, Ga. 6s to 26s; cops, cones. Edward S. Hyde, Phila., s. agt.

Cutler Mfg. Co., Warren, R. I. 5s to 26s; cones, tubes. Wm. D'Olier & Co., Phila., s. agts.

Dana Warp Mills, Westbrook, Me. 8s to 50s; cops, skeins.

Delph Spinning Co., The, Rosehill and C sts., Phila., Pa. 8s to 24s; cones. Jas. E. Mitchell & Co., Phila., s. agts.

Dexter Yarn Co., Pawtucket, R. I. 6s to 30s; cops, skeins, cones. Sell direct.

Germantown Spinning Co., High St. and R. R.R., Germantown, Phila., Pa. 8s to 24s; skeins, cones, cops. Sell direct.

Greene & Daniels Mfg. Co., Pawtucket, R. I. 20s to 60s; cones, tubes. Sell direct.

Hebron Mfg. Co., Hebronville, Mass. 8s to 26s; skeins, spools, cops, cones. Sell direct.

Henry, Thos. Jr., East Stroudsburg, Pa. 6s to 30s; cops, cones. Sell direct.

Irving & Leiper Mfg. Co., Chester, Pa. 6s to 22s; cones, tubes. Sell direct.

Jagers, Thos., Allegheny Ave. and Emerald St., Phila., Pa. 6s to 24s; cones, cops. Sell direct.

Lawrenceville Mfg. Co., Lawrenceville, Ga. 8s to 26s; cops, cones, tubes.

Lawton Spinning Company, Providence, R. I. All numbers, cones, tubes, skeins, cops. Sell direct.

New England Cotton Yarn Co., New Bedford, Mass. All numbers, furnished in any form. Sell direct through New Bedford office.

New Hampshire Spinning Mills, 30s to 80s; skeins, cones, tubes, ball warps. Am. Cotton Yarn Exchange, s. agts.

The New York Mills, New York Mills, Oneida Co., N. Y. All numbers; cops, cones, tubes. Sell direct.

Ontario Spinning Co., 1729 Philip St., Phila., Pa. 10s to 22s; cones, tubes. Sell direct.

Orswell Mills, Fitchburg, Mass. All numbers; cones, tubes. Sell direct.

Raleigh Cotton Mills, Raleigh, N. C. 5s to 30s; cones, tubes, skeins. Jas. E. Mitchell & Co., Phila., Pa.

Richmond Spinning Co., Chattanooga, Tenn. 14s to 30s; cones, tubes. A. B. Sanford, s. agt. and sell direct.

Skenandoa Cotton Co., Utica, N. Y. 5s to 60s; cops, skeins, universal cones. Sell direct.

Standard Cotton Mills, Cedartown, Ga. 10s to 26s; cops, cones, tubes. C. E. Riley & Co., Boston, s. agts.

Standard Spinning Co., Chester, Pa. 8s to 24s; cones. Sell direct.

Tennille Cotton Mills, Tennille, Ga. 10s to 30s; cops, cones, tubes. Wm. D'Olier & Co., s. agts.

Union Mfg. Co., Union Point, Ga. 10s to 26s; cops, cones, tubes. Sell direct.

Utica Cotton Co., Capron, N. Y. 6s to 30s; cops and cones. J. H. Lane & Co., N. Y., s. agts.

Utica Steam and Mohawk Valley Cotton Mills, Utica, N. Y. All numbers; cops, cones, skeins, tubes. Sell direct.

Utica Spinning Co., Utica, N. Y. 10s to 24s; cones, cops. Sell direct.

Valatie Cotton Mill, Valatie, N. Y. 10s to 24s; cones, cops. Sell direct.

Walcott & Campbell Spinning Co., New York Mills, N. Y. All numbers; cops, cones, skeins. Sell direct.

Walker, Isaac, Frankford, Phila., Pa. 6s to 20s; cones, tubes. Sell direct.

Whitaker, Wm. & Sons, Olney Road, Frankford, Phila., Pa. 14s to 26s; cones. Sell direct.

Williams, A., & Co., So. Woodstock, Conn. 6s to 18s; cops, skeins, cones, tubes. Sell direct.

Winsor Spinning Co., Greenville, R. I. 24s to 45s; cones, tubes. Sell direct.

Wolfenden, Shore, & Co., Cardington, Pa. 14s to 20s; cones. Sell direct.

---



---

# CATLIN & CO.

345-347 Broadway, New York.

67 Chauncy St., Boston.

206 Chestnut St., Philadelphia.

---



---

## COTTON YARNS

ALL NUMBERS IN

AMERICAN, SEA ISLAND,

PERUVIAN and EGYPTIAN.

Single or Twisted, Skeins, Chains,  
Beams, Balls, Spools, Cops,  
Cones or Tubes.

.. .. *CARDED AND COMBED.* .. ..

..... ALSO .....

Jaegers, Silvers and Solid Colors.

**Carded Mule Spun Peruvian.**

New England Cotton Yarn Co., New Bedford, Mass. All numbers, furnished in any form. Sell direct through New Bedford office.

**Skenandoo Cotton Co., The,** Utica, N. Y. All numbers; cop, skein, cone. Sell direct.

**Carded Mule Spun Twist and Ply.**

Centreville Mfg. Co., Rockville, R. I. 24s to 26s; cones, tubes. Eddy & Street, Providence, s. agts.

Cumberland Mills Co., Valley Falls, R. I. 10s to 30s; cones, tubes, skeins. Sell direct.

**Dexter Yarn Co.,** Pawtucket, R. I. 6s to 30s; skeins, cones. Sell direct.

**Greene & Daniels Mfg. Co.,** Pawtucket, R. I. 20s to 60s; cones, skeins, tubes. Sell direct.

**Jenckes, E. Mfg. Co.,** Pawtucket, R. I. All numbers; cones, tubes. Sell direct.

Phoenix Factory, Debruce, Ga. 6s to 16s; skeins, cones.

**Skenandoo Cotton Co., The,** Utica, N. Y. All numbers; cones, skeins. Sell direct.

**Utica Steam and Mohawk Valley Cotton Mills,** Utica, N. Y. All numbers; skeins, cones, tubes. Sell direct.

**Carded Mule Spun Colored.**

**Dana Warp Mills,** Westbrook, Me. 8s to 50s; cops, skeins.

**Greene & Daniels Mfg. Co.,** Pawtucket, R. I. 20s to 60s; skeins, cops, cones. Sell direct.

**Jenckes, E., Mfg. Co.,** Pawtucket, R. I. All numbers; cones, tubes, cops. Sell direct.

**New York Mills, The,** New York Mills, Oneida Co., N. Y. All numbers; cones, tubes, skeins. Sell direct.

**Utica Steam and Mohawk Valley Cotton Mills,** Utica, N. Y. All numbers; skeins, cops, cones, tubes. Sell direct.

**New Bedford Cotton Yarn Co.,** New Bedford, Mass. All numbers, furnished in any form. Sell direct through New Bedford office.

Soque Mills, Cornelia, Ga. 12s to 20s; skeins, cones. J. F. White & Co., N. Y. and Phila., s. agts.

**Walcott & Campbell Spinning Co.,** New York Mills, N. Y. All numbers; cops, cones, skeins. Sell direct.

Warren, W., Thread Works, Westfield, Mass. 6s to 30s; cones, tubes, skeins. Sell direct.

Winghocking Mills Co., Frankford, Phila., Pa. 2s to 20s; cones. Sell direct.

**Carded Ring Spun.**

Adelaide Mills, Anniston, Ala. 10s to 20s; cones. Sell direct.

Alpha Cotton Mills, Jonesville, S. C. cones. Sell direct.

American Spinning Co., Greenville, S. C. 8s to 20s; skeins, tubes, cones. Catlin & Co., N. Y. and Boston, s. agts.

Anchor Mills, Huntersville, N. C. 10s to 30s; cones, tubes. Sell direct.

Annestown Cotton Mill, Atlanta, Ga. 6s to 30s; cones, tubes. Chas. M. McCloud & Co., Phila., s. agts.

Anniston Yarn Mills Co., Anniston, Ala. 20s to 26s; cones.

Ashbey Cotton Mills, Marion, S. C. 12s to 20s; cones, tubes. R. A. Blythe, Phila., s. agt.

Athens Cotton Mills Co., Athens, Ala. 16s to 20s; cones.

Athens Mfg. Co., Athens, Ga. 6s to 16s; cones. Buckingham & Paulson, N. Y., Schell, Taylor, and Longstreth, Phila., s. agts.

Atkins & Pearce Mfg. Co., The, Cincinnati, Ohio. 14s to 24s; cones. Sell direct.

Atlantic and Gulf Mills, Quitman, Ga. 10s to 22s; cones, skeins. Catlin & Co., Boston and N. Y., s. agts.

Batesville Mfg. Co., Greenville, S. C. 14s to 16s; cones, tubes. Catlin & Co., Boston, s. agts.

Bessie Minge Mfg. Co., Demopolis, Ala. 1s to 8s; skeins, cones. Catlin & Co., s. agts.

Boscawen Mills, Penacook, N. H. 4s to 18s; cones, tubes. Sell direct.

Briggs Mfg. Co., The, Volentown, Conn. 8s to 50s; skeins, cones, tubes. Sell direct.

Calmacha Cotton Co., Sanford, N. C. 14s to 26s; cones. Catlin & Co., Wm. D'Olier & Co., s. agts.

Cameron Cotton Mill Co., Cameron, N. C. 6s to 12s; cones. Sell direct.

Capps Cotton Mill, Toccoa, Ga. 20s to 24s; Foster cones. Haines & Bishop, N. Y., s. agts.

Cedar Shoals Mfg. Co., Richburg, S. C. 8s to 20s; cones, tubes. Sell direct.

Cherryville Mfg. Co., Cherryville, N. C. 20s to 40s; cones. W. M. & F. W. Sharples, Phila., s. agts.

Chinnabee Cotton Mills, Talladega, Ala. 10s to 20s; cones, tubes. Sell direct.

Clayton Cotton Mill, Clayton, N. C. 18s to 30s; cones, tubes. Sell direct.

Cordele Cotton Mills Co., Cordele, Ga. 12s to 24s; cones, tubes.

Cronicle Mills, The, Belmont, N. C. 16s to 26s; cones, tubes. Sell direct.

**Dana Warp Mills,** Westbrook, Me. 8s to 50s; cops.

Dellma Cotton and Woolen Mills, Lincoln, N. C. 14s to 20s; cones. Wm. D'Olier & Co., Boston, s. agts.

# FINE HOSIERY YARNS

**In Cop, Skein and Cone.**

Also Yarns of Combed Peeler,

Egyptian, and Peruvian Cottons.

Universal Cones a Specialty.

**The SKENANDOA COTTON COMPANY, UTICA, N. Y.**

N. E. KERNAN, Pres.

N. E. DEVEREUX, Sec. and Treas.

D. W. GRAY, Supt.

LONG DISTANCE TELEPHONE NO 966

## Walcott & Campbell Spinning Co.,

**IROQUOIS MILL.**

NEW YORK MILLS, ONEIDA COUNTY, N. Y.

**STAPLE AND FANCY HOSIERY YARNS.**

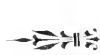

SOLID COLORS, RANDOMS, MIXES, BLEACHED,  
AMERICAN, EGYPTIAN, STAINED EGYPTIAN,  
CONES, COPS OR SKEINS.

BLEACHING AND DYEING IN ROLL OR PIECE.

W. S. WALCOTT, PRES.

S. R. CAMPBELL, TREAS.

### THE NEW YORK MILLS

**CORDUROY** in all grades and shades for Men's Wear, Ladies' Dress Goods, Hats, Trimmings, Skirt Binding and Furniture.

**PLAIN AND FANCY SHIRTINGS**—Madras, Cheviot, Lenox

**SHEETS**, Pillow Cases and Bolsters made from heavy Sheetings, 42 in. to 108 in.

**SATEENS** and Standard Three and Five Leaf Twills.

**YARNS**—Warp and Hosiery, Coarse and Fine, Combed or Carded, Single or Twisted, Gassed, Bleached, Dyed or Mercerized.

*Also Job Dyeing, Bleaching and Mercerizing of Yarn and Piece Goods*

Selling Agents for Yarns.

Selling Agents for Piece Goods.

**New York Mills,** Oneida County,  
New York.

**A. J. Juilliard & Co.,** 70 Worth St.,  
New York

## UTICA STEAM AND MOHAWK VALLEY COTTON MILLS,

UTICA, N. Y.

### COTTON YARNS

*Combed and Carded Peelers. Solid Colors—Mixtures.*

**Cops**  
**Singles and Twisted**

**Skeins**

**Cones and Tubes**  
**Universal Wind**

- Dexter Yarn Co.**, Pawtucket, R. I. 6s to 30s; cops, skeins, cones. Sell direct.
- Dixie Cotton Mills**, La Grange, Ga. 8s to 30s; cones, tubes. Converse, Stanton & Co., and J. Spencer Turner Co., N. Y., s. agts.
- Durham Hosiery Mills**, Durham, N. C. 8s to 30s; cones, tubes. Sell direct.
- Edgefield Mfg. Co.**, Edgefield, S. C. 16s to 20s; cones, skeins. Sell direct.
- Efird Mfg. Co.**, Albermarle, N. C. 8s to 20s; cones, skeins. Sell direct.
- Elizabeth Cotton Mills**, Atlanta, Ga. 8s to 24s; skeins, cones. Sell direct.
- Elk Cotton Mills**, Fayetteville, Tenn. 26s to 30s; cones, tubes. Sell direct.
- Excelsior Knitting Mills**, Union, S. C. 12s to 30s; cones, tubes. Sell yarns direct.
- Fountain Cotton Mills**, Tarboro, N. C. 18s to 30s; cones. Sell direct.
- Gate City Cotton Mills**, Atlanta, Ga. 6s to 22s; cones. Sell direct.
- Gold Crown Hosiery Mills**, Charlotte, N. C. 18s to 26s; cones. Wm. D'Olier & Co., Phila., s. agts.
- Greene & Daniels Mfg. Co.**, Pawtucket, R. I. 20s to 60s; cones, tubes. Sell direct.
- Hampton Cotton Mills**, Hampton, Ga. 6s to 20s; cones. Sell direct.
- Harriet Cotton Mills**, Henderson, N. C. 7s to 16s; cones, tubes. Sell direct.
- Harriman Cotton Mill Co.**, Harriman, Tenn. 8s to 30s; cones, tubes. Sell direct and through agents.
- Hawkinsville Cotton Mills**, Hawkinsville, Ga. 8s to 24s; cones, spools, skeins.
- Henderson Cotton Mills**, Henderson, N. C. 22s to 26s; cones. Sell direct.
- Highland City Mills**, Talladega, Ala. 12s to 20s; cones. Catlin & Co., s. agts.
- Hutcheson Mfg. Co.**, Banning, Ga. 2s to 18s; cones, tubes. Sell direct.
- Indian Orchard Co.**, Indian Orchard, Mass. All numbers; skeins, cones, tubes. Sell direct.
- Kinston Cotton Mills**, Kinston, N. C. 8s to 30s; cones, tubes. Sell direct.
- Knoxville Cotton Mills**, Knoxville, Tenn. 6s to 30s; cones, tubes. Sell direct.
- La Grange Mills**, La Grange, Ga. 4s to 12s; cones, tubes. J. H. Lane & Co., N. Y., and Boston, s. agts.
- Lane Mills of New Orleans**, New Orleans, La. 12s to 20s; cones, tubes. Sell direct.
- Lawton Spinning Company**, Providence, R. I. All numbers, cones, tubes, skeins. Sell direct.
- Lincoln Mfg. Co.**, Chester, Pa. 12s to 30s; cones, sell direct.
- Louisville Cotton Mills Co.**, Louisville, Ky. 3s to 30s; cones, tubes, skeins, cops. Waters, Garland Co., Louisville, s. agts.
- Lumberton Cotton Mills**, Lumberton, N. C. 20s to 32s; cones. Sell direct.
- McColl Mfg. Co.**, McColl, S. C. 8s to 40s; cones, tubes. Wm D'Olier & Co., s. agts.
- Madison County Spinning Co.**, 16s to 26s; cones.
- Magnolia Mills**, Charlotte, N. C. 30s to 40s; cones, cops. Wm. D'Olier & Sons, s. agts.
- Maiden Cotton Mills**, Maiden, N. C. 14s to 26s; skeins, cones. Jas. E. Mitchell, N. Y., and Boston, s. agts.
- Manchester Mfg. Co.**, Macon, Ga. 2s to 20s; cones, tubes. Sell direct.
- Marie Cotton Mills**, McColl, S. C. 20s to 30s; cones, tubes. Wm. D'Olier & Co., and J. H. Lane & Co., s. agts.
- Mobile Cotton Mills**, Mobile, Ala. 6s to 24s; cones. Sell direct.
- Monbo Mfg. Co.**, Monbo, N. C. 8s to 22s; cones. Jas. E. Mitchell & Co., Phila., s. agts.
- Montgomery Co., The J. R.**, Windsor Locks, Conn. 1s to 100s; cops, cones. Sell direct.
- New England Cotton Yarn Co.**, New Bedford, Mass. All numbers, furnished in any form. Sell direct through New Bedford office.
- Octoraro Mills Co.**, Clio, S. C. 12s to 26s; cones, tubes. Sell direct.
- Orswell Mills**, Fitchburg, Mass. All numbers; cones, tubes. Sell direct.
- Park Mills**, La Grange, Ga. 6s to 20s; cones, tubes. Sell direct.
- Paterson Manufacturing Co.**, China Grove, N. C. 8s to 30s; cones, tubes. C. J. Webb & Co., s. agts.
- Pelham Mills**, Pelham, S. C. 10s to 16s; cones, tubes. Wm. D'Olier & Co., s. agts.
- Pepperton Cotton Mills**, Jackson, Ga. 20s to 24s; cones, tubes. J. L. Bailey & Co., s. agts.
- Piedmont Mfg. Co.**, Piedmont, S. C. 8s to 14s; cones, tubes. Catlin & Co., N. Y. and Boston, s. agts.
- Quinn Mfg. Co.**, Petersburg, Va. 14s to 26s; cones, tubes. Richard A. Blythe, Phila., s. agt.
- Quintette Mfg. Co.**, Eatonton, Ga. 2s to 18s; skeins, cones, tubes. Haines & Bishop, N. Y., s. agts.
- Scotland Cotton Mills**, Laurinburg, N. C. 26s to 40s; cones. Sell direct.
- Seneca Cotton Mills**, Seneca, S. C. 14s to 24s; cones. Sell yarns direct.
- Skenandoa Cotton Company**, The, Utica, N. Y. All numbers; cones, skeins. Sell direct.
- Smith, J. E.**, Cotton Mfg. Co., Thomson, Ga. 16s to 26s; cones, tubes.
- Smithfield Cotton Mills**, Smithfield, N. C. 20s to 26s; cones, tubes. Sell direct.
- Springfield Cotton Mills**, Laurel Hill, N. C. 6s to 14s; cones, tubes. Catlin & Co., Boston, Eddy & Street, Prov., and Schell, Taylor & Longstreth, Phila., s. agts.
- Standard Spinning Co.**, Chester, Pa. 8s to 24s; cones. Sell direct.
- Statesville Cotton Mills**, Statesville, N. C. 8s to 30s; skeins, tubes, cones. J. H. Lane & Co., N. Y., s. agts.

Sutherland Mfg. Co., Augusta, Ga. 4s to 30s; skeins, cones, tubes. Schell, Taylor, and Longstreth, Phila., Eddy & Street, Prov., and J. H. Lane & Co., N. Y., s. agts.

Sutro Cotton Mill Co., Yorkville, S. C. 10s to 20s; cones, tubes. Sell direct.

Sycamore Mills, Sycamore, Ala. 10s to 26s; cops, cones. Sell direct.

Talladega Cotton Factory, Talladega, Ala. 6s to 24s; cones. Wm. D'Olier & Co., Phila., s. agts.

Toccoa Cotton Mills, The, Toccoa, Ga. 6s to 20s; cones. Wm. D'Olier & Co., Phila., s. agts.

Tolar Hart & Holt Mills, Fayetteville, N. C. 10s to 24s; cones, tubes. Sell direct.

**Tucker & Cook Mfg. Co.**, Conway, Mass. 6s to 30s; cones. Sell direct.

Tuscarora Cotton Mill, Mt. Pleasant, N. C. 24s; cones, tubes. C. J. Webb & Co., Phila., and James Freeman Brown, N. Y., s. agts.

**Utica Steam and Mohawk Valley Cotton Mills**, Utica, N. Y. All numbers; skeins, cones, tubes. Sell direct.

Victor Cotton Mills, Charlotte, N. C. 20s to 30s; cones, cops. Jas. E. Mitchell & Co., Phila., and Boston, s. agts.

Victoria Cotton Mill, Rock Hill, S. C. 20s to 30s; cones, tubes. Sell yarns direct and Hunter Mfg. & Com. Co., s. agt.

**Whittier Mills**, Springfield, Mass. 2s to 40s; cones, tubes, skeins. Sell direct.

Willard Mfg. Co., Willardsville, N. C. 14s to 20s; cones. Sell direct.

Wiscasset Mills Co., Albermarle, N. C. 20s to 40s; cones, tubes, skeins, ball warps. Chas. J. Webb & Co., Phila., and sell direct.

Woodstock Cotton Mills, Anniston, Ala. 10s to 26s; cones. Catlin & Co., N. Y., s. agts.

Yocona Mills, Water Valley, Miss. 5s to 30s; cones, tubes. Sell direct.

### Carded Ring Spun Colored.

**Dana Warp Mills**, Westbrook, Me. 8s to 50s; cops. Sell direct.

**Greene & Daniels Mfg. Co.**, Pawtucket, R. I. 20s to 60s; cones, tubes. Sell direct.

Henry, Thos., Jr. & Co., Milton, Pa. 6s to 16s; cones, tubes. Sell direct.

**Indian Orchard Co.**, Indian Orchard, Mass. All numbers; skeins, cones, tubes. Sell direct.

**Jenekes, E. Mfg. Co.**, Pawtucket, R. I. All numbers; cones, tubes, cops. Sell direct.

**Montgomery Co., The J. R.**, Windsor Locks, Conn. 1s to 100s; cops, cones. Sell direct.

New England Cotton Yarn Co., New Bedford, Mass. All numbers, furnished in any form. Sell direct through New Bedford office.

Savannah Cotton Mills, Savannah, Ga. 6s to 32s; cones, tubes, skeins. Sell direct.

**Tucker & Cook Mfg. Co.**, Conway, Mass. 6s to 30s; cones. Sell direct.

**Utica Steam and Mohawk Valley Cotton Mills**, Utica, N. Y. All numbers; skeins, tubes, cones. Sell direct.

Warren, W., Thread Works, Westfield, Mass. 6s to 30s; cones, tubes, skeins. Sell direct.

**Whittier Mills**, Springfield, Mass. 2s to 40s; cones, tubes, skeins. Sell direct.

### Carded Ring Spun Twist and Ply.

Belmont Cotton Mills, Shelby, N. C. 10s to 20s; cones, skeins. Jas. E. Mitchell & Co., Phila., s. agts.

Central Mills, Sylacauga, Ala. 18s to 22s; cones. Sell direct.

**Commonwealth Cotton Mfg. Co.**, Durham, N. C. 6s to 26s; cones. Sell direct.

**Dana Warp Co.**, Westbrook, Me. 8s to 50s; cones. Sell direct.

Dardanelle Cotton Mill, Dardanelle, Ark. 2s to 12s; skeins, cones, tubes. Sell direct.

**Dexter Yarn Co.**, Pawtucket, R. I. 6s to 30s; skeins, cones. Sell direct.

Elm Grove Cotton Mills, Lincolnton, N. C. 20s to 40; cones, tubes. Sell direct.

Forsyth Mfg. Co., Forsyth, Ga. 6s to 14s; tubes, skeins. Sell direct.

**Greene & Daniels Mfg. Co.**, Pawtucket, R. I. 20s to 60s; cones, tubes. Sell direct.

**Indian Orchard Co.**, Indian Orchard, Mass. All numbers; skeins, cones, tubes. Sell direct.

**Jenekes, E., Mfg. Co.**, Pawtucket, R. I. All numbers; cones, tubes, cops. Sell direct.

Kenyon, John T., Woodville, R. I. 10s to 24s; cones, tubes, skeins. Sell direct.

Long Island Cotton Mills, Long Island, N. C. Office at Statesville. 19s to 20s; cones, tubes. Wm. D'Olier & Co., Phila., s. agts.

Monroe Cotton Mills, Monroe, N. C. 20s to 40s; cones. Catlin & Co., N. Y., and Boston, s. agts.

**Montgomery Co., The J. R.**, Windsor Locks, Conn. 1s to 100s; skeins, cones. Sell direct.

National Spinning Co., Orchard St., Frankford, Phila., Pa. 1s to 30s; cones, skeins, tubes. James E. Mitchell & Co., s. agts.

New England Cotton Yarn Co., New Bedford, Mass. All numbers, furnished in any form. Sell direct through New Bedford office.

Newton Cotton Mills, Newton, N. C. 8s to 20s; cones. Sell through agts.

Ohlo Falls Warp Mill, New Albany, Ind. 6s to 12s; cones, tubes.

**Skenndooa Cotton Company, The**, Utica, N. Y. All numbers; cones, skeins. Sell direct.

Spencer Mountain Mills, Lowell, N. C. 16s to 26s; cones. Sell direct.

Stimpson & Steele, Turnersburg, N. C. 6s to 20s; cones, skeins. Jas. E. Mitchell & Co., Phila., s. agts.

Tifton Cotton Mills Co., Tifton, Ga. 2s to 40s; 1, 2, 3 and 4 ply. cones, skeins. Sell direct.

**Utica Steam and Mohawk Valley Cotton Mills**, Utica, N. Y. All numbers; skeins, cones, tubes. Sell direct.

**Tucker & Cook Mfg. Co.**, Conway, Mass. 8s to 20s; cones, tubes, skeins. Sell direct.

Wadesboro Cotton Mills Co., Wadesboro, N. C. 20s to 30s; cones, Wm. D'Olier & Co., Phila., s. agts.

West Huntsville Cotton Mills Co., Huntsville, Ala. 2s to 14s; cones. J. H. Lane & Co., N. Y., C. J. Webb & Co., Phila., s. agts.

White Hall Yarn Mill, White Hall, Ga. 7s to 16s; tubes, skeins. Catlin & Co., s. agts.

**Whittier Mills**, Springfield, Mass. 2s to 40s; in all ply. cones, tubes, skeins. Sell direct.

### Combed Mule Spun American Peeler and Egyptian.

Avalon Mills, Mayodan, N. C. 6s to 30s; tubes, cones. H. M. Daniel, Phila., s. agt.

Beatty, Robt., & Co., Coral and Adams Sts., Phila., Pa. 16s to 40s; cones, tubes. Sell direct.

Columbia Spinning Co., Inc. Haines St. near Stenton Ave., Germantown, Phila., Pa. 12s to 30s; cones, cops, tubes. Sell direct.

**Dexter Yarn Co.**, Pawtucket, R. I. 4s to 30s; skeins, cops, cones, tubes. Sell direct.

**Greene & Daniels Mfg. Co.**, Pawtucket, R. I. 8s to 30s; cones, tubes. Sell direct.

**Jenkes, E., Mfg. Co.**, Pawtucket, R. I. 8s to 30s; cops, cones, tubes. Sell direct.

**Lawton Spinning Company**, Providence, R. I. All numbers, cones, tubes, skeins, cops. Sell direct.

Massaemet Yarn Mills, Shattuckville, Mass. 40s to 60s; cones, tubes, dresser spools. Sell direct.

Mayo Mills, The, Mayodan, N. C. 6s to 30s; cones, tubes. H. M. Daniel, Phila., s. agt.

New England Cotton Yarn Co., New Bedford, Mass. All numbers, furnished in any form. Sell direct through New Bedford office.

New Hampshire Spinning Mills. 40s to 80s; skeins, cones, warps. Am. Cotton Yarn Exvhange, s. agts.

**New York Mills, The**, New York Mills, Oneida Co., N. Y. All numbers; cops, cones, tubes. Sell direct.

**Orswell Mills**, Fitchburg, Mass. All numbers; cones, tubes. Sell direct.

**Skenandoa Cotton Company, The**, Utica, N. Y. All numbers; cops, cones, skeins. Sell direct.

**Utica Steam and Mohawk Valley Cotton Mills**, Utica, N. Y. All numbers; cops, cones, tubes, skeins. Sell direct.

**Walcott & Campbell Spinning Co.**, New York Mills, N. Y. All numbers; cops, cones, skeins. Sell direct.

Warren Mfg. Co., Warren, R. I. 14s to 24s; cones, tubes. Sell yarns direct.

### Combed Mule Spun Colored.

**Grant Yarn Co.**, Fitchburg, Mass. 40s and above; skeins, cops. Sell direct.

**Greene & Daniels Mfg. Co.**, Pawtucket, R. I. 8s to 30s; cones, tubes. Sell direct.

**Jenkes, E., Mfg. Co.**, Pawtucket, R. I. 8s to 30s; cops, cones, tubes. Sell direct.

**New York Mills, The**, New York Mills, Oneida Co., N. Y. All numbers; cones, tubes, skeins. Sell direct.

Tremont & Suffolk Mills, Lowell, Mass. All numbers; skeins, cops, cones, tubes. Smlth, Hogg & Gardner, Boston and N. Y., s. agts.

**Utica Steam and Mohawk Valley Cotton Mills**, Utica, N. Y. All numbers; cops, cones, tubes, skeins. Sell direct.

**Walcott & Campbell Spinning Co.**, New York Mills, Oneida Co., N. Y. All numbers; cones, cops, skeins. Sell direct.

Warren, W., Thread Works, Westfield, Mass. 6s to 30s; cones, tubes, skeins. Sell direct.

### Combed Ring Spun Peeler and Egyptian.

Cranska, Floyd, Moosup, Conn. 30s to 60s; skeins, cones, tubes. Sell direct.

**Dexter Yarn Co.**, Pawtucket, R. I. 4s to 30s; skeins, cones, tubes. Sell direct.

**Greene & Daniels Mfg. Co.**, Pawtucket, R. I. 8s to 30s; cones, tubes. Sell direct.

**Jenkes, E., Mfg. Co.**, Pawtucket, R. I. 8s to 30s; cops, cones, tubes. Sell direct.

**Lawton Spinning Company**, Providence, R. I. All numbers, cones, tubes, skeins, cops. Sell direct.

New England Cotton Yarn Co., New Bedford, Mass. All numbers, furnished in any form. Sell direct through New Bedford office.

**Orswell Mills**, Fitchburg, Mass. All numbers; cones, tubes. Sell direct.

Ozark Cotton Mills, Gastonia, N. C. 20s to 40s; cones, tubes. Jas. E. Mitchell & Co., Phila., s. agts.

**Skenandoa Cotton Company, The**, Utica, N. Y. All members; cones, skeins. Sell direct.

Star Thread Mills, Athens, Ga. 10s to 16s; cops. Schell, Taylor & Longstreth, Phila., s. agts.

**Utica Steam and Mohawk Valley Cotton Mills**, Utica, N. Y. All numbers; cones, tubes, skeins. Sell direct.

### Jaeger Yarns.

**Jenkes, E., Mfg. Co.**, Pawtucket, R. I. All numbers; cones, tubes, cops. Sell direct.

C. T. CROCKER, Pres.

W. F. STILES, Treas.

# ORSWELL MILLS,

Fitchburg, Mass.

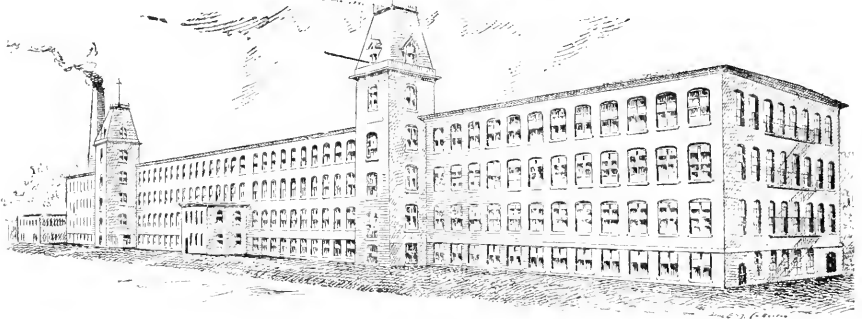

Capacity 45,000 Spindles.

## HIGH GRADE YARNS

FROM

EGYPTIAN AND PEELER COTTONS, CARDED OR COMBED

IN CHAINS AND SKEINS, ON BALLS, BEAMS, SPOOLS,  
COPS, CONES, TUBES, SINGLE OR TWISTED.

L. R. PECK, Pres.

F. C. FLETCHER, Vice-Pres.

W. O. TODD, Sec'y. and Treas.

## LAWTON SPINNING COMPANY,

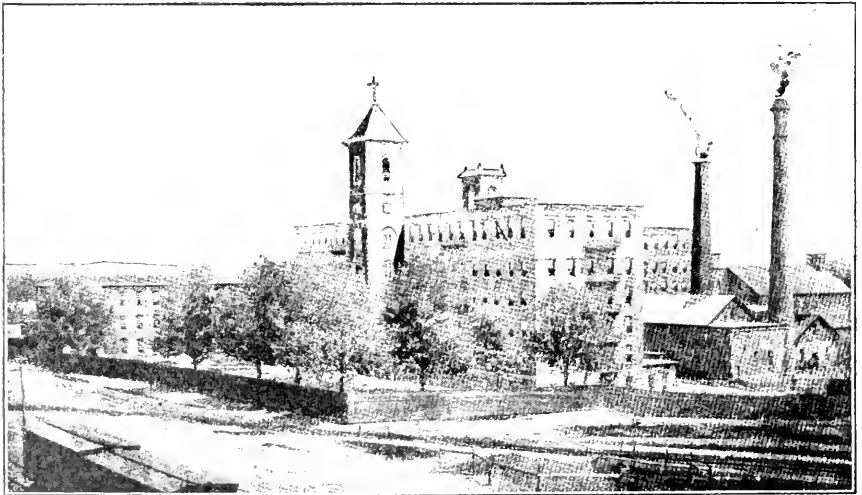

## FINE COTTON YARNS.

Mills at WOONSOCKET, R. I.

Office, Room 621 Banigan Building, PROVIDENCE, R. I.



**Montgomery Co., The J. R.,** Windsor Locks, Conn. 1s to 80s; skeins, cops, cones. Sell direct.

**New York Mills, The,** New York Mills, Oneida Co., N. Y. All numbers; cones, tubes, skeins. Sell direct.

**Utica Steam and Mohawk Valley Cotton Mills,** Utica, N. Y. All numbers; cops, cones, tubes, skeins. Sell direct.

**Walcott & Campbell Spinning Co.,** New York Mills, N. Y. All numbers; cops, cones, skeins. Sell direct.

### Fancy Mixes.

**Greene & Daniels Mfg. Co.,** Pawtucket, R. I. 20s to 60s; cones, tubes. Sell direct.

**Indian Orchard Co.,** Indian Orchard, Mass. All numbers; skeins, cones, tubes. Sell direct.

**Jenckes, E., Mfg. Co.,** Pawtucket, R. I. All numbers; cones, tubes, cops. Sell direct.

**Montgomery Co., The J. R.,** Windsor Locks, Conn. 10s to 100s; skeins, cops, cones, tubes. Sell direct.

**New York Mills, The,** New York Mills, Oneida Co., N. Y. All numbers; cones, tubes, skeins. Sell direct.

Standard Yarn Co., Oswego, N. Y. 4s to 24s; large cops, cones, skeins. Catlin & Co., N. Y., Boston and Phila., and James E. Mitchell & Co., s. agts.

**Tucker & Cook Mfg. Co.,** Conway, Mass. 6s to 30s; cones. Sell direct.

**Utica Steam and Mohawk Valley Cotton Mills,** Utica, N. Y. All numbers; cops, cones, tubes, skeins. Sell direct.

**Walcott & Campbell Spinning Co.,** New York Mills, N. Y. All numbers; cops, cones, skeins. Sell direct.

## COTTON WEAVING YARNS.

### Carded Single Skeins.

Blue Ridge Cotton Mill, Petersburg, Va. 10s to 26s; skeins. Sell direct.

**Bonnie Cottton Mills,** King's Mountain, N. C. 4s to 40s; skeins, warps. W. M. & F. W. Sharples, Phila., s. agts.

**Canonchet Mills,** Canonchet, R. I. 6s to 22s; skeins, warps. Sell direct.

**Charlotte Cordage Co.,** Charlotte, N. C. 10s to 24s; skeins. Sell direct.

**Cohankus Mfg. Co.,** Paducah, Ky. 3s to 10s; skeins, spools. Putnam, Hooker, & Co., s. agts.

**Cora Cotton Mills,** King's Mountain, N. C. 6s to 16s; skeins. W. M. & F. W. Sharples, Phila., s. agts.

**Dana Warp Mills,** Westbrook, Me. 8s to 50s; any form. Sell direct.

**Edwards, James R.,** Estate of, Canonchet, R. I. 8s to 12s; skeins. Sell direct.

**Ellawhite Cotton Mills,** Uniontown, Ala. 14s to 16s; skeins. Sell direct.

**Fairfield Cotton Mills,** Winnsboro, S. C. 10s to 30s; skeins. Woodward, Baldwin & Co., N. Y., s. agts.

**Graham, H. H. & T. H.,** Pinewood, Tenn. 14s to 20s; skeins. Sell direct.

**Grant Yarn Co.,** Fitchburg, Mass. 40s to 80s; skeins, cones, tubes, spools, beams, ball warps. Sell direct.

**Greene & Daniels Mfg. Co.,** Pawtucket, R. I. 8s to 80s; skeins. Sell direct.

**Goldville Mfg. Co.,** Goldville, S. C. 24s to 26s; skeins. Sell direct.

**High Shoals Co.,** High Shoals, N. C. 20s to 26s; skeins. Sell direct.

**High Shoals Mfg. Co.,** High Shoals, Ga. 8s to 32s; skeins, cones, tubes. Putnam, Hooker & Co., W. M. & F. W. Sharples, s. agts.

**Holmes, John C. & Co.,** Springfield, Vt. 12s to 26s; skeins, dresser spools, beams, warps. Sell direct.

Humboldt Cotton Mill, Humboldt, Tenn. 20s; skeins. Sell direct.

Indian Creek Mills, Lincolnton, N. C. 15s to 26s; skeins. W. M. & F. W. Sharples, Phila., s. agts.

**Indian Orchard Co.,** Indian Orchard, Mass. All numbers; skeins. Sell direct.

**Jenckes, E., Mfg. Co.,** Pawtucket, R. I. All numbers; skeins. Sell direct.

**Johnson, E. Emory,** Moodus, Conn. 10s to 12s; skeins.

**Johnson, R.,** Yarn & Cordage Mills, Madison, Ind. 8s to 12s; skeins, tubes. Sell direct.

**Lenoir Cotton Mill,** Lenoir, N. C. 20s to 40s; skeins. Chas. J. Webb & Co., s. agts.

**Long Shoals Cotton Mills,** Long Shoals, N. C. 19s to 26s; skeins. W. M. & F. W. Sharples, Phila., s. agts.

**Montgomery Co., The J. R.,** Windsor Locks, Conn. 1s to 40s; skeins. Sell direct.

**Muscogee Mfg. Co.,** Columbus, Ga. 4s to 20s; skeins, cones, tubes. Sell direct.

**Orswell Mills,** Fitchburg, Mass. All numbers; skeins, cops. Sell direct.

**Palmetto Cotton Mills,** Palmetto, Ga. 8s to 32s; skeins, cones. Robinson, Hughes Co., s. agts.

**Pendleton Mfg. Co.,** Autun, S. C. 3s to 10s; cones, tubes, skeins. Jas. E. Mitchell & Co., Phila., s. agts.

**Phoenix Mfg. Co.,** Peterboro, N. H. 20s to 40s; skeins, cones, tubes. Parker, Wilder & Co., s. agts.

**Snow, J.,** Hardware Co., Tuscaloosa, Ala. 10s to 14s; skeins. Robinson, Hughes & Co., Louisville, s. agts.

**Spray Cotton Mills,** Spray, N. C. 20s to 40s; skeins. Sell direct.

**Swift's Cotton Mill,** Elberton, Ga. 4s to 40s; skeins, cones, tubes. Sell direct.

**Thompson Bros.,** Turnerville, Conn. 2s to 6s; skeins.

Tipton Cotton Mills, Covington, Tenn 14s to 30s; skeins. Sell direct.

Trio Mfg. Co., Forsyth, Ga. 4s to 20s; skeins, warps. Sell direct.

**Tucker & Cook Mfg. Co.**, Conway, Mass. 8s to 20s; skeins. Sell direct.

Union Springs Cotton Mills, Union Springs, Ala. 6s to 16s; skeins, cops, cones. Chas. J. Webb, Phila., s. agt.

Vivian Cotton Mills, Cherryville, N. C. 8s to 16s; skeins. Buckingham & Paulson, N. Y., and Catlin & Co., Boston. s. agts.

West Huntsville Cotton Mills Mfg. Co., Huntsville, Ala. 2s to 14s; warps, spools, skeins. J. H. Lane & Co., N. Y., C. J. Webb & Co., Phila., s. agts.

Wehadkee Cotton Mills, Rock Mills, Ala. 4s to 12s; skeins. Sell direct.

Williamstown Mfg. Co., Williamstown, Mass. 10s to 60s; skeins.

Wylie Mill, Chester, S. C. 30s to 40s; skeins. Chas. J. Webb & Co., s. agts.

### Carded Two Ply Skeins.

Argo Mills Co., Gloucester City, N. J. 10s to 100s; skeins, cones. Sell direct through Phila. office.

Arlington Cotton Mills, Arlington, S. C. 6s to 14s; skeins. Sell direct.

Capelsie Cotton Mills, Troy, N. C. 14s; skeins. Sell direct.

Carolina Mills, The, Greenville, S. C. 20s to 30s; skeins, cones, tubes. Sell through agents.

Cherry Cotton Mills, Florence, Ala. 8s to 50s; chains, skeins, beams, warps. Schell, Taylor & Longstreth, Phila., Pa., s. agts.

Chromal Mill, Belmont, N. C. 16s to 26s; skeins. Sell direct.

**Dana Warp Mills**, Westbrook, Me. 8s to 50s.

**Dexter Yarn Co.**, Pawtucket, R. I. 4s to 30s; skeins. Sell direct.

Edwards, J. N., Shoal Creek, Ga. 4s to 12s, skeins, ball warps. Buckingham & Paulson, N. Y., s. agts.

Elizabeth Mills, The, Charlotte, N. C. 40s to 60s, Egyptian; skeins. Sell direct.

Eno Cotton Mills, Hillsboro, N. C. 20s; chains, ball warps. Sell direct.

Fingerville Mfg. Co., Fingerville, S. C. 14s; skeins. James E. Mitchell & Co., Philadelphia, s. agts.

Gaffney Mfg. Co., Gaffney, S. C. 30s; skeins. Sell yarn direct.

Georgia Mfg. Co., White Hall, Ga. 20s to 40s; skeins. Catlin & Co., N. Y., Buckingham & Paulson, N. Y., and W. M. & F. W. Sharples, Phila., s. agts.

**Grant Yarn Co.**, Fitchburg, Mass. 40s to 80s; skeins, cones, tubes, spools, beams, ball warps. Sell direct.

**Greene & Daniels Mfg. Co.**, Pawtucket, R. I. 8s to 80s; skeins. Sell direct.

Handley, The W. A. Mfg. Co., Roanoke, Ala. 20s to 30s; skeins, linked warps. Sell direct.

Harden Mfg. Co., Harden, N. C. 19s to 26s; skeins. W. M. & F. W. Sharples, Phila., s. agts.

Henrietta Mills, The, Henrietta, N. C. 8s; skeins. Catlin & Co., N. Y., s. agts.

High Falls Manufacturing Co., High-falls, N. C. 8s to 12s; 1, 2 and 3 ply skeins. Jas. M. White & Co., N. Y., and Phila., s. agts.

Hogansville Mfg. Co., Hogansville, Ga. 16s and coarser; skeins. Sell direct.

Holt-Williamson Mfg. Co., Fayetteville, N. C. 4s to 26s; skeins. Buckingham, Paulson & Co., s. agts.

Ida Yarn Mill, Laurel Hill, N. C. 12s to 14s; skeins. Eddy & Street and Schell, Taylor & Longstreth, s. agts.

**Indian Orchard Co.**, Indian Orchard, Mass. All numbers; skeins. Sell direct.

**Jenkes, E., Mfg. Co.**, Pawtucket, R. I. All numbers; skeins. Sell direct.

Jonesboro Cotton Mills Co., Jonesboro, N. C. 12s to 16s; also three and four ply skeins. Sell direct.

Kenyon, John T., Woodville, R. I. 10s to 24s; cones, tubes, skeins. Sell direct.

Kindley, W. R., Cotton Mills, Mt. Pleasant, N. C. 26s to 40s, 2 and 3 ply; skeins. Wm. D'Olier & Co., Phila., s. agts.

King's Mountain Mfg. Co., King's Mountain, N. C. 18s to 26s; skeins. W. M. & F. W. Sharples, Phila., s. agts.

Lancaster Mfg. Co., Lancaster, Mass. 20s to 40s; skeins. Sell direct.

Lavonia Cotton Mills, Lavonia, Ga. 10s to 20s; to 4 ply; skeins. Sell direct.

Limestone Mfg. Co., Gaffney, S. C. 30s; skeins. Chas. J. Webb & Co., s. agts.

Linden Manufacturing Co., Dallas, N. C. 24s to 30s; skeins. Eddy & Street, s. agts.

Lippard Yarn Mill, Concord, N. C. 14s; skeins. Sell direct.

Lulu Mfg. Co., Kings Mountain, N. C. 14s to 20s, skeins. Sell direct.

Maxton Cotton Mills, Maxton, N. C. 10s to 16s; skeins. Sell direct.

Modena Cotton Mills, Gastonia, N. C. 24s to 34s; skeins. Chas. J. Webb & Co., Phila., s. agts.

**Montgomery Co., The J. R.**, Windsor Locks, Conn. 1s to 40s; skeins. Sell direct.

New England Cotton Yarn Co., New Bedford, Mass. All numbers, furnished in any form. Sell direct through New Bedford office.

Piedmont Cotton Mills, Atlanta, Ga. 12s to 16s; skeins. Sell direct.

**Orswell Mills**, Fitchburg, Mass. All numbers; skeins, cops. Sell direct.

Premier Cotton Mills, Helena, Ark. 40s to 60s; skeins.

Rocky Mount Mills, Rocky Mount, N. C. 8s to 22s; skeins. Sell through agents.

Robertson, W. G., Staley, N. C. 14s to 26s; skeins. Sell direct.

Rodman Heath Cotton Mill, Maxhaw, N. C. 24s to 40s; skeins. W. M. & F. W. Sharples, s. agts.

Roxboro Cotton Mills, Roxboro, N. C. 20s; skeins, chain warps. Wm. D'Olier & Co., Phila., s. agts.

Royall Cotton Mills, Wake Forest, N. C. 20s to 30s; skeins. Sell direct.

Shuford Mfg. Co., Hickory, N. C. 20s to 40s; skeins. Sell direct.

Smitherman Cotton Mills, Troy, N. C. 12s to 14s; skeins. Wm. D'Olier & Co., and Thomas & Houston, Phila., s. agts.

Tuckasee Mfg. Co., Mt. Holly, N. C. 12s to 20s; skeins. Sell direct and Jas.

- E. Mitchell & Co., Phila. and Boston, s. agts.
- Tucker & Cook Mfg. Co.**, Conway, Mass. 8s to 20s; skeins. Sell direct.
- Vance Cotton Mill Co., Chattanooga, Tenn. 2s to 10s; cones, tubes, skeins. Sell direct.
- Wayne Cotton Mills, Goldsboro, N. C. 20s to 40s; skeins. Wilson & Bradbury, Phila., and N. Y., s. agts.
- West Point Cotton Mills, West Point, Miss. 40s to 50s; skeins, chains, warps.
- Willingham Cotton Mills, Macon, Ga. 6s to 12s; cones, tubes, skeins, ball warps. Sell direct.
- Witham Cotton Mills, The, Hartwell, Ga. 8s to 26s; skeins, spools. Wm. D'Olier & Co., s. agts.
- 
- Carded Single Warps.**
- 
- Adamsdale Mill, Adamsdale, Mass. 40s to 60s; warps, skeins, chains, spools. W. M. & F. W. Sharples, Phila., s. agts. and sell direct.
- Alpine Cotton Mills, Morgantown, N. C. 8s to 12s; warps. Sell direct.
- Argonaut Cotton Mill Co., Covington, Ky. 8s to 8½s; warps. Putnam, Hooker & Co., Cincinnati, s. agts.
- Bala Cotton Mills, Concord, N. C. 10s to 24s; warps, ball warps, chains. Sell direct.
- Birmingham Cotton Mfg. Co., Birmingham, Ala. 12s to 30s; warps.
- Borden Mfg. Co., Goldsboro, N. C. 20s to 40s; chains. Sell direct.
- Canoe River Mills, Taunton, Mass. 30s to 60s; cones, skeins, chains, ball warps. J. E. Mitchell & Co., Phila., and Boston, s. agts.
- Cornelius Cotton Mills, Dallas, N. C. 5s to 36s; ball warps. Sell direct.
- Dana Warp Mills**, Westbrook, Me. 8s to 50s; chains, warps, beams.
- Dexter Yarn Co.**, Pawtucket, R. I. All numbers; skeins, chains, warps, beams. Sell direct.
- Dickey, W. J., & Sons, Oella, Md. 10s to 20s; chains, ball warps. J. W. Dickey & Sons, N. Y., s. agts.
- Franklinville Mfg. Co., Franklinville, N. C. 12s to 24s; chains and ball warps. E. H. Hamilton & Co., N. Y., and Jas. E. Mitchell & Co., Phila., s. agts.
- Gary, J. S. & Sons, Alberton, Md. 10s to 20s; chains, warps, ball warps. Sell direct.
- Gastonia Cotton Mfg. Co., Gastonia, N. C. 25s to 40s; chains, ball warps. Jas. E. Mitchell & Co., Phila., and Boston, s. agts.
- Gibson Mill, Concord, N. C. 20s to 40s; skeins, chains, ball warps. Sell direct.
- Glover Mfg. Co., Juliette, Ga. 4s to 18s; skeins, 2 to 10 ply. Sell direct.
- Grant Yarn Co.**, Fitchburg, Mass. 40s to 50s; skeins, spools, beams, ball warps. Sell direct.
- Greene & Daniels Mfg. Co.**, Pawtucket, R. I. 8s to 80s; chains, skeins, ball warps. Sell direct.
- Hamburg Cotton Mills, Mt. Airy, N. C. 6s to 18s; chains, warps. Sell direct.
- Hazelhurst Cotton Mills, Mt. Airy, N. C. 5s to 16s; warps, chains. Sell direct.
- Hlawatha Mfg. Co., Gibsonville, N. C. 15s to 25s; warps, chains. Sell direct.
- Holt Morgan Mills, Fayetteville, N. C. 8s to 20s; warps. Wilson & Bradbury, Phila., s. agts.
- Hurricane Creek Mfg. Co., Spring Garden, Ala. 6s to 12s; warps. B. M. & J. E. Stewart, s. agts.
- Indian Orchard Co.**, Indian Orchard, Mass. All numbers; chains, ball warps, beams, skeins. Sell direct.
- Indiana Warp Mills, Indianapolis, Ind. 10s to 12s; warps, chains, ball warps. Sell direct.
- Jenkes, E., Mfg. Co.**, Pawtucket, R. I. All numbers; jack spools, ball warps. Sell direct.
- Kelley, T. J., Newton, Ala. 8s to 10s; warps. Sell direct.
- Knoxville Woolen Mills, Knoxville, Tenn. 6s to 20s; skeins, chains, beams. Sell direct.
- Levi Cotton Mills Co., Rutherfordton, N. C. 20s to 40s; chains, skeins. Sell direct, and P. Burnstine, Bond St., N. Y., s. agts.
- Libbey & Dingley Co., Lewiston, Me. 40s; ball warps.
- Lloyd, Thomas F., Chapel Hill, N. C. 16s to 24s warps; ball warps, chains. Sell direct.
- Montgomery Co., The J. R.**, Windsor Locks, Conn. 1s to 40s; chains, beams, warps, ball warps. Sell direct.
- Monument Mills**, Housatonic, Mass. 4s to 60s; chains, ball warps, beams. Sell direct.
- New England Cotton Yarn Co., New Bedford, Mass. All numbers, furnished in any form. Sell direct through New Bedford office.
- Newman Cotton Mills, Newman, Ga. 6s to 26s; warps, chains, ball warps. Sell direct.
- Norwood Mfg. Co., Norwood, N. C. 20s to 40s; warps. Sell through agts.
- Odell, J. M., Mfg. Co., Bynum, N. C. 22s to 24s; warps, ball warps, chains. Sell direct.
- Orswell Mills**, Fitchburg, Mass. All numbers; chains, warps, ball warps, beams, spools. Sell direct.

**JOHN C. HOLMES CO.,**

SPRINGFIELD, VT.

**COTTON WARPS,**

Plain, Dyed and Bleached. Custom Work Solicited.

**SPECIALTY OF BLACKS FAST TO FULLING.**

- Payne Cotton Mills, Macon, Ga. 4s to 16s; warps, chains, ball warps, beams. Sell direct.
- Pearl Cotton Mills, Beverly, Ga. 6s to 14s; W. M. & F. W. Sharples, Chas. J. Webb & Co., and Wm. D'Olier & Co., s. agts.
- Peck, J. L. & T. D., Mfg. Co., Pittsfield, Mass. 10s to 26s; dresser spools, beams. sell direct.
- Rockville Warp Mills Co., Rockville, Conn. 4s to 20s; warps, beams, skeins. Sell direct.
- Sanford Cotton Mills, Sanford, N. C. 14s to 20s; chains, ball warps. Sell direct.
- Slater, Wm. A., Mills, Jewett City, Conn. 20s to 40s; beams, warps, spools. Sell direct.
- Stanley Creek Cotton Mills, Stanley, N. C. 16s to 30s; chains, ball warps. Sell direct.
- Sterling Cotton Mills, Franklinton, N. C. 12s to 22s; chain and ball warps. Sell direct.
- Tucker & Cook Mfg. Co.**, Conway, Mass. 6s to 30s; chains, beams, jack spools. Sell direct.
- Union Cotton Mills, Maiden, N. C. 14s to 30s; warps. Jas. E. Mitchell & Co., Phila., s. agts.
- Vance Cotton Mills, Salisbury, N. C. 14s to 24s; skeins, chain warps. Sell direct and through commission house.
- Whittier Mills**, Springfield, Mass. 2s to 40s; warps, beams, ball warps. Sell direct.
- 
- Carded Two Ply Warps.**
- 
- Ada Mfg. Co., Charlotte, N. C. 8s to 20s; warps, ball warps, chains. Sell direct and through agts.
- Albion Co., Mt. Holly, N. C. 4s to 16s; chains, ball warps. Sell direct.
- Arlington Cotton Mills, The, Gastonia, N. C. 40s to 60s; one, two and three-ply chains and ball warps. Sell direct.
- Ashuelet Warp Co., Ashuelet, N. H. 14s to 40s; beams. Sell direct.
- Atherton Mills Co., Charlotte, N. C. 26s to 40s; tubes, skeins, ball warps. Sell direct.
- Avon Mills, Gastonia, N. C. 40s to 50s; chains, ball warps. Jas. E. Mitchell & Co., Phila., s. agts.
- Barker Mill, Auburn, Me. 20s to 45s; warps, beams, ball warps, filling, cops. Sell direct.
- Bennettsville Mfg. Co., Bennettsville, S. C. 8s to 26s; skeins, chains, ball warps. Wm. D'Olier & Co., s. agts.
- Briggs Mfg. Co., The, Rockville, R. I. 24s to 36s; chains, ball warps, skeins. Sell direct.
- Buffalo Mfg. Co., Stubbs, N. C. 30s; chains, ball warps. Catlin & Co., Phila., s. agts.
- Camden Cotton Mill, Camden, S. C. 14s to 30s; skeins, chains and ball warps. Sell yarns direct.
- Cannon Manufacturing Co., Concord, N. C. 20s to 40s; warps, ball warps, chains. Sell direct, and Catlin & Co., s. agts.
- Catawba Cotton Mill, Newton, N. C. 30s; chains, ball warps. Chas. J. Webb & Co.; Buckingham, Paulson & Co., and H. Seving & Co., s. agts.
- Chester Mfg. Co., Chester, Pa. 8s to 26s; skeins, chains, ball warps. W. M. & F. W. Sharples, Phila., s. agts.
- City Mfg. Corp., New Bedford, Mass. 20s to 120s; skeins, chains, warps, ball warps. Sell direct.
- Cochran Cotton Mills Co., Cochran, Ga. 16s to 30s; warps, ball warps, beams.
- Coleman Mfg. Co., Concord, N. C. 20s to 30s; warps, chains. Sell direct.
- Coosa Mfg. Co., Piedmont, Ala. 20s to 30s; warps, chains. Sell direct.
- Cox Mfg. Co., Anderson, S. C. 40s; skeins, warps, chains. Sell direct.
- Cumberland Cotton Mills, Cumberland, N. C. 8s to 16s; warps, chains, ball warps. Sell through agts.
- Dana Warp Mills**, Westbrook, Me. 8s to 50s; warps.
- Dallas Cotton Mills, Dallas, N. C. 18s to 30s; warps, ball warps. C. J. Webb & Co., Phila., s. agts.
- Dexter Yarn Co.**, Pawtucket, R. I. All numbers; sheins, chains, warps, beams. Sell direct.
- Dickson Cotton Mill, Laurinburg, N. C. 14s to 16s; skeins, chain warps. Sell direct.
- Dover Yarn Mills, Charlotte, N. C. 30s to 40s; warps, chains, ball warps. W. M. & F. W. Sharples & Co., Phila., s. agts.
- Dustin, W. H. & Son, Strathmore, Tenn. 4s to 16s; ball warps. Sell direct.
- Edenton Cotton Mills, Edenton, N. C. 24s to 26s; skeins, warps. D'Olier & Loeb, Phila., agts.
- Elizabeth City Cotton Mills, Elizabeth City, N. C. 8s to 30s, 2 and 3 ply, skeins, chain warps. James E. Mitchell & Co., Phila., s. agts.
- Eureka Cotton Mills, Chester, S. C. 12s to 30s; skeins, ball warps. C. J. Webb & Co., Phila., s. agts.
- Fayetteville Cotton Mills, Fayetteville, N. C. 1s to 20s; warps. Jas. E. Mitchell, Phila. and Boston, s. agts.
- Fountain Inn Mfg. Co., Fountain Inn, S. C. 40s; skeins, chains, ball warps. Jas. E. Mitchell & Co., Phila., s. agts.
- Gaston Mfg. Co., Cherryville, N. C. 40s; skeins, warps, ball warps. Catlin & Co., s. agts.

# COTTON WARPS,

8 to 50 White or Colored.

Cotton Grain Bags.

*Dana Warp Mill, - - Westbrook, Me.*

- Georgia Mfg. Co., White Hall, Ga. 20s to 24s; beams. Catlin & Co., N. Y., s. agts.
- Grant Yarn Co.**, Fitchburg, Mass. 40s to 80s; skeins, spools, warps. Sell direct.
- Greene & Daniels Mfg. Co.**, Pawtucket, R. I. 8s to 80s; chains, skeins, ball warps. Sell direct.
- Holmes, John C., Co.**, Springfield, Vt. 12s to 26s; skeins, dresser spools, beams, warps. Sell direct.
- Holt-Williamson Mfg. Co., Fayetteville, N. C. 4s to 26s; chains, skeins, warps. Buckingham, Paulson & Co., s. agts.
- Huntsville Cotton Mills Co., Huntsville, Ala. 10s to 20s; warps. Buckingham, Paulson & Co.; Wm. D'Olier & Co.; C. J. Webb & Co., s. agts.
- Indian Orchard Co.**, Indian Orchard, Mass. All numbers; skeins, chains, warps, ball warps, beams. Sell direct.
- Jamestown Cotton Mills, Jamestown, N. Y. 30s to 50s; warps, skeins, cones, tubes. Sell direct and Wilson & Bradbury, Phila., s. agts.
- Jenkes, E., Mfg. Co.**, Pawtucket, R. I. All numbers; jack spools, ball warps. Sell direct.
- Juanita Cotton Mills, Burlington, N. C. 10s to 22s; warps, chains. Jas. E. Mitchell & Co., Phila., s. agts.
- Kesler Mfg. Co., Salisbury, N. C. 18s to 30s; chains, skeins, ball warps. Sell direct.
- Knight, A. F., Woonsocket, R. I. 20s to 60s; beams, skeins, ball warps. Sell direct.
- Laboratory Cotton Mills, Lincolnton, N. C. 40s; skeins, warps, chains. Chas. J. Webb & Co., s. agts.
- Lancaster Cotton Mills, Lancaster, S. C. 20s to 40s; skeins, chains, ball warps.
- Lawton Spinning Co.**, Providence, R. I. Fine counts; skeins, chains, warps.
- Leak, Wall & McRae, Midway Mills, Rockingham, N. C. 12s; chains, ball warps. W. M. & F. W. Sharples, Phila., Catlin & Co., s. agts.
- Lincoln Cotton Mills, Lincolnton, N. C. 40s to 60s; warps, chains, skeins. Sell direct.
- Littlefield Mfg. Co., Pawtucket, R. I. 6s to 40s; warps, skeins, chains. Sell direct.
- Lowell Cotton Mills, Lowell, N. C. 20s to 50s; warps; two and three-ply. Sell direct.
- Manchester Cotton Mills, Rock Hill, S. C. 20s to 40s; skeins, chains, ball warps. Richard A. Blythe, Phila., s. agt.
- Manetta Mills, Lando, S. C. 30s to 40s; skeins, chains, ball warps. Catlin & Co., s. agts.
- Millen Cotton Mills, Millen, Ga. 26s to 40s; warps, skeins. T. B. Tiedman, N. Y., s. agt.
- Monument Mills**, Housatonic, Mass. 4s to 60s; chains, ball warps, beams. Sell direct.
- Mooresville Cotton Mills, Mooresville, N. C. 26s to 40s, chains, ball warps. Catlin & Co.; Buckingham & Paulson, and W. M. & F. W. Sharples, s. agts.
- Montgomery Co., The J. R.**, Windsor Locks, Conn. 1s to 80s; chains, beams, warps, ball warps. Sell direct.
- Newton Cotton Mills, Newton, N. C. 8s to 30s; chains, skeins, ball warps. Sell through agts.
- Opelika Cotton Mills, Opelika, Ala. 14s to 40s; warps, beams, ball warps. Sell direct.
- Orient Mfg. Co., Charlotte, N. C. 24s to 40s; warps, chains. Sell direct.
- Oriental Mfg. Co., Providence, R. I. 20s to 60s; skeins, warps, chains. Sell direct.
- Orswell Mills**, Fitchburg, Mass. All numbers; chains, warps, ball warps, beams, spools. Sell direct.
- Oxford Cotton Mill Co., Oxford, N. C. 8s to 12s, to 8 ply; cones, tubes, skeins, cops, dresser spools, beams, ball warps, short chain warps. Sell direct.
- Peck, J. L. & T. D., Mfg. Co., Pittsfield, Mass. 10s to 26s; dresser spools, beams. Sell direct.
- Providence Cotton Mills, Maiden, N. C. 2s to 26s; chains, ball warps. Buckingham, Paulson & Co., N. Y. and Phila., s. agts.
- Ravine Mills Co., Vernon, Conn. 6s to 24s; skeins, beams, warps, bobbins. Sell direct.
- Riverside Mfg. Co., Anderson, R. I. 20s to 30s; skeins, warps, chains. James E. Mitchell & Co., s. agts.
- Roswell Mfg. Co., Roswell, Ga. 20s to 40s; warps, ball warps, skeins. Jas. H. White & Co., N. Y. and Phila., and Cooley, Turnbull & Co., N. Y., s. agts.
- Shelby Cotton Mills, Shelby, N. C. 30s to 40s; skeins, chains. Catlin & Co., N. Y., s. agts.
- South Side Mfg. Co., Winston-Salem, N. C. 14s to 40s; skeins, chains, ball warps. R. A. Blythe, Phila., s. agt.
- Stafford Mfg. Co., Central Falls, R. I. 16s to 60s; skeins, warps. Sell direct, also W. M. & F. W. Sharples, Phila., s. agts.
- Tarboro Cotton Factory, Tarboro, N. C. 16s to 32s; chains, ball warps. Sell direct.
- Thompson, A. J., Laurel Bluff, N. C. 8s to 20s; chains, ball warps. Jas. E. Mitchell & Co., Phila., s. agts.
- Trenton Cotton Mills, Gastonia, N. C. 4s to 60s; one two and three ply cones, tubes, skeins, chains, ball warps. Jas. E. Mitchell & Co., Phila., s. agts.
- Tricker & Cook Mfg. Co.**, Conway, Mass. 8s to 20s; beams, ball warps. Sell direct.

## MONUMENT MILLS,

Manufacturers of

White, Colored, Fancy and

Double and Twist,

HOUSATONIC, MASS.

# COTTON WARPS

4s to 60s.

Wayman Cotton Mills, Wayman, Ga. 4s to 14s; warps, chains. Sell direct.

**Whittier Mills**, Springfield, Mass. 2s to 40s; warps, beams, ball warps. Sell direct.

Wilson Cotton Mills, Wilson, N. C. 6s to 20s; skeins, chains, ball warps. Sell direct.

Winthrop Mills, Winthrop, Me. 10s to 20s; chains, warps, ball warps, beams. W. L. Strong & Co., N. Y., s. agts.

Worth Mfg. Co., The, Worthville, N. C. 6s to 24s; skeins, chains, ball warps. Sell direct.

Wyoming Mills, Norristown, Pa. 20s to 40s; chains, skeins, ball warps. Jas. E. Mitchell & Co., Phila., s. agts.

York Cotton Mill, Yorkville, S. C. 24s to 60s; skeins, chains, ball warps, in single to four ply. Sell direct and through agts.

---

### Combed Peeler, Egyptian and Sea Island Warps.

---

Brignton Mills, Passaic, N. J. 10s to 24s; warps, skeins, chains. Sell direct.

Clark, Wm., Co., Westerly, R. I. 20s to 30s; skeins, spools, tubes. American Thread Co., New York, s. agts.

Clover Cotton Mfg. Co., Clover, S. C. 30s to 60s; skeins, chains, ball warps. Sell direct and J. H. Lane & Co., s. agts.

Chadwick, Jas., & Bro., Jersey City, N. J. 20s to 200s; cops, cones, skeins. Sell direct.

**Dana Warp Mills**, Westbrook, Me. 8s to 50s; single and ply.

Daniel Mfg. Co., Lincolnton, N. C. 50s to 100s; warps, chain and ball. Sell direct.

**Dexter Yarn Co.**, Pawtucket, R. I. 4s to 30s; beams, ball warps. Sell direct.

**Grant Yarn Co.**, Fitchburg, Mass. 40s to 80s; skeins, spools, warps. Sell direct.

**Greene & Daniels Mfg. Co.**, Pawtucket, R. I. 8s to 80s; chains, skeins, ball warps. Sell direct.

**Indian Orchard Co.**, Indian Orchard, Mass. All numbers; jack spools, beams, skeins, warps. Sell direct.

**Jenkes, E., Mfg. Co.**, Pawtucket, R. I. 8s to 40s; skeins, ball warps. Sell direct.

Kennebec Spinning Mills, Richmond, Me. 3s to 26s; beams, ball warps, up to 8 ply. Am. Cotton Yarn Exchange, s. agts.

**Montgomery Co., The J. R.**, Windsor Locks, Conn. 1s to 100'; chains, skeins, beams, warps, ball warps, cones, tubes. Sell direct.

New England Cotton Yarn Co., New Bedford, Mass. All numbers, furnished in any form. Sell direct through New Bedford office.

New Hampshire Spinning Mills. 40s to 80s; skeins, cones, warps. Am. Cotton Yarn Exchange, s. agts.

**Orswell Mills**, Fitchburg, Mass. All numbers; chains, warps, ball warps, beams, spools. Sell direct.

Trainer, D. & Sons, Mfg. Co., Trainer, Pa. 20s to 80s; skeins, warps. Sell direct.

---

WM. H. GREENE, TREAS.

HENRY C. DEXTER, AGT.

## GREENE & DANIELS MFG. CO.,

Combed, Carded and Gassed, American and Egyptian

# Yarns, Threads, Twines and Chain Warps,

Colored and Bleached Yarns Furnished in any manner desired by the trade. Sell direct.

**PAWTUCKET,**

**RHODE ISLAND.**

---

## E. Jenckes Mfg. Co., Pawtucket, R. I.

—SPINNERS OF—

### *Cotton Yarns, Carded and Combed,*

White or Colored.

Cops, Cones, Tubes or Skeins.

DOUBLE AND TWIST YARNS AND BLACK COTTON FOR THE WOOLEN TRADE A SPECIALTY.

### Colord Weaving Yarns.

**Adams Bros. Mfg. Co., Adams, Mass.** 4s to 60/2s; dresser spools, beams, warps, ball warps. Sell direct.

**Appleton Co., Lowell, Mass.** All numbers; chains, warps, ball warps, skeins, tubes. Catlin & Co., N. Y., Boston and Phila., s. agts.

**Boott Cotton Mills, Lowell, Mass.** All numbers; chains, warps, ball warps, skeins, tubes. Smith, Hogg & Gardner, N. Y. and Boston, s. agts.

**Dana Warp Mills, Westbrook, Me.** 4s to 50s; chains, skeins, beams, warps, ball warps. Sell direct.

**Greene & Daniels Mfg. Co., Pawtucket, R. I.** 8s to 80s; chains, skeins, ball warps. Sell direct.

**Gwyn-Harper Mfg. Co., Patterson, N. C.** 10s to 20s; skeins. Sell yarns direct.

**Hamilton Web Co., Hamilton, R. I.** 6s to 40s; skeins, chains, warps. Sell direct.

**Holmes, John C. Co., Springfield, Vt.** 12s to 26s; skeins, dresser spools, beams, warps. Sell direct.

**Holt, L. Banks, Graham, N. C.** 14s; skeins, chains, warps. Cone Export & Com. Co., s. agts.

**Holyoke Warp Co., Holyoke, Mass.** 5s to 40s; warps, ball warps, chains. Sell direct.

**Indian Orchard Co., Indian Orchard, Mass.** All numbers; skeins, warps. Sell direct.

**Jenckes, E., Mfg. Co., Pawtucket, R. I.** All numbers; jack spools, ball warps. Sell direct.

**Montgomery Co., The J. R., Windsor Locks, Conn.** 1s to 100s; chains, skeins, beams, warps, ball warps. Sell direct.

**Monument Mills, Housatonic, Mass.;** 4s to 60s; chains, ball warps, beams. Sell direct.

**New England Cotton Yarn Co., New Bedford, Mass.** All numbers, furnished in any form. Sell direct through New Bedford office.

**Plunkett, W. C., & Sons, Adams, Mass.** 6s to 120s; chains, warps, beams, ball warps. Sell direct.

**Renfrew Mfg. Co., Adams, Mass.** 10s to 50s; warps, chains, ball warps, spools. P. Van Volkenburg & Co., s. agts.

**Roanoke Mills Co., Roanoke Rapids, N. C.** 20s to 40s; skeins. J. W. Cooke & Co., Phila., s. agts.

**Rodman Mfg. Co., Allenton, R. I.** All sizes, single and two-ply; warps, chains, beams, skeins. Sell direct.

**Stonewell Cotton Mills, Stonewell, Miss.** 2s to 24s, 1 to 5-ply; skeins, chains, warps, beams, cones, tubes. Sell direct.

**Tucker & Cook Mfg. Co., Conway, Mass.** 6s to 30s; chains, beams, jack spools. Sell direct.

**Wennonah Cotton Mills, Lexington, N. C.** 20s to 30s; skeins, cones, tubes, warps. Cone Export & Com. Co., s. agts.

**White, Williamson & Co., Saxapahaw, N. C.** 6s to 26s, single and ply warps; chains, skeins. Buckingham Paulson & Co., s. agts.

**Whittier Mills, Springfield, Mass.** 2s to 40s; warps, beams, ball warps. Sell direct.

**Wilkesbarre Lace Mfg. Co., Wilkesbarre, Pa.** 10s to 50s; chains, skeins. Yarns Sold direct.

**Worth Mfg. Co., Central Falls, N. C.** 6s to 24s; skeins, chains, ball warps. Sell direct.

### Carpet Yarns.

**Beaumont Mfg. Co., Spartanburg, S. C.** 6s to 8s; warps, two and three ply. Sell direct and Jas. E. Reynolds & Co., N. Y., s. agts.

**Cleveland Cotton Mills, Lawndale, N. C.** 4s to 12s in ply; warps. Jas. E. Reynolds & Co., N. Y., s. agts.

**Columbia Cotton Mills, Columbia, Ala.** 6½s to 8s, in 3 to 8-ply; skeins. Sell direct. Wm. O'Oliver & Co., s. agts.

**Cornelson, Geo. H., Orangeburg, S. C.** 4s to 12s, 3 and 4-ply warps. Jas. E. Reynolds & Co., N. Y., s. agts.

**Double Shoal Cotton Mills, Double Shoal, N. C.** 8s to 14s; warps. Jas. E. Reynolds, s. agt.

**Eagle Cotton Mills, Lawrenceburg, Tenn.** 4s to 20s, in ply; warps. Sell direct.

**Eagle Cotton Mills Co., Madison, Ind.** 1s to 10s; warps, ball warps, chains. J. H. Lane & Co., Chicago and N. Y., s. agts.

**Eldorado Cotton Mills, Milledgeville, N. C.** 8s to 12s; warps, chains. Sell direct.

**Elkin Mfg. Co., Elkin, N. C.** 4s to 12s, 2 3 and 4-ply, warps. Sell direct.

**Enterprise Mfg. Co., Coleridge, N. C.** 7s to 10s, 2, 3 and 4-ply, warps. Jas. F. White & Co., N. Y., s. agts.

**Fork Shoals Cotton Mill Co., Fork Shoals, S. C.** 6s to 14s; skeins, chains, ball warps, two to five ply. Sell direct.

**Franklin Mills, Greer Depot, S. C.** 8s to 12s; skeins, chains, ball warps, single and two ply.

**Granite Falls Mfg. Co., Granite Falls, N. C.** 8s to 14s, in ply; chains, warps. Sell direct.

## GRANT YARN CO.

Combed Cotton  
Yarns and Warps,

Peeler, Egyptian and Sea Island.  
40s to 80s.

FITCHBURG, MASS.

# The Wm. H. Lorimer's Sons Co.

Manufacturers of

## MERCERIZED YARNS

FOR ALL PURPOSES,

MERCERIZERS AND DYERS.

New York Office:

Room 911 New York Life Building,  
346 Broadway,

Ontario & Lawrence Sts.  
PHILADELPHIA, PA.

Hadley, People's Mfg. Co., Siler City, N. C. 3s to 16s, slack reeled ply yarns. John Corbet & Son, Phila., s. agts.

Hooster Dye Works & Mfg. Co., New Albany, Ind. 1s to 12s; skeins, tubes. Sell direct.

January & Wood Co., Maysville, Ky. 4s to 8s; chains, warps, ball warps. Sell direct, and Putnam, Hooker & Co., Cincinnati, s. agts.

Jones, J. F., Laurel Mills, Laurel, N. C. 4s to 12s in ply; warps. Sell direct.

Lauraglenn Mills, Shelby, N. C. 8s to 14s; warps, chains. Amon, Green & Co., Balto., s. agts.

Ledbetter Mfg. Co., South Union Mills, Lockingham, N. C. 8s to 12s; chains, ball warps. Hooper, Sewing & Co., Phila., s. agts.

Mary Louise Mill, Cowpens, S. C. 12s; skeins, chains, ball warps. Catlin & Co., New York and Boston, s. agts.

Morris & Ott, Burnside St., Maunayunt, Phila., Pa., wool spun. 8 to 30 cut; skeins, cops and back wound. J. Corbet & Son, Phila., s. agts.

Nims Mfg. Co., Mt. Holly, N. C. 14s to 22s, two to eight ply; warps. Sell direct, and Buckingham, Paulson & Co., N. Y., s. agts.

Parkdale Cotton Mills, Jamestown, N. C. 2s to 20s, two to ten ply; warps. Sell direct.

## J. S. DODDS,

517 Wool Exchange, New York, N. Y.

## Mercerized Yarns

Two and Three Ply for all Purposes.

In Peeler, Egyptian and Sea Island, gassed and ungassed, natural and dyed. East Black for cross dyeing a specialty.

Through H. A. CAESAR & CO.

Pendleton Mfg. Co., Autun, S. C. 3s to 10s; skeins, ball warps, chains; one, two and three ply. James E. Mitchell & Co., Phila., s. agts.

Stowesville Cotton Mill, Belmont, N. C. 8s, three to four ply. Sell direct. Sumter Cotton Mills, Sumter, S. C. 8s to 12s; skeins, two and three ply. Sell direct.

Taylor Mfg. Co., Pottersville, Ga. 8s to 12s; skeins. W. T. Hanson, Bibb Mfg. Co., Macon, Ga., s. agts.

Tennessee Mfg. Co., Nashville, Tenn. 8s to 40s; warps. Sell direct.

Wahoo Mfg. Co., Sargent, Ga. 4s to 12s; warps. O. D. Loeb, Phila., s. agts.

Whittier Mills, Springfield, Mass. All numbers, in ply; warps, beams, ball warps. Sell direct.

### Wool Spun Cotton Yarn.

Beacon Mfg. Co., New Bedford, Mass. All numbers; cops, cones, tubes, skeins. Sell direct from Boston office.

Broadbent, J. & Son, Unionville, Conn. All numbers; skeins, cops. Sell direct.

Burns, John, Ardmore, Pa. Double reel carpet yarns.

Farrell, Henry B., Howard and Berks Sts., Phila., Pa. 20 to 46 cut; cops, cones, tubes. Sell direct.

Hampton Co., East Hampton, Mass. Sell direct.

Perry Yarn Mill, Webster, Mass. 1 to 10 Rs; cops, bobbins, spools, skeins. Sell direct.

Whitaker, Wm. D., Emerald and Westmoreland Sts., Phila., Pa. Single and double reel. Sell direct.

### Mercerized Yarns.

American Thread Co., New York, N. Y. All numbers; cones, tubes, skeins, cops, beams, ball warps, etc.





GASSING,  
BLEACHING,  
DYEING,  
WINDING.

EASTHAMPTON, MASS.

**Birkhead Spinning Co.**, Lawrence, Lu-  
zerne and Fifth Sts., Phila., Pa. 20s to  
60s; cops, skeins, warps, etc., in colors.  
Sell direct.

**Grant Yarn Co.**, Fitchburg, Mass. 40s  
to 80s; cones, tubes, skeins, spools,  
beams, ball warps. Sell direct.

**Greene & Daniels Mfg Co.**, Pawtucket,  
R. I. 8s to 80s; chains, skeins, ball  
warps. Sell direct.

**Hampton Co.**, East Hampton, Mass.  
Sell direct.

**Indian Orchard Co.**, Indian Orchard,  
Mass. All numbers; skeins, warps,  
spools. Sell direct.

**Lorimer's, W. H. Sons & Co.**, Ontario  
and Lawrence Sts., Phila., Pa. 2s to  
150s; two ply, skeins, sell direct.

**Montgomery Co., The J. R.** Windsor  
Locks, Conn. 1s to 100s; chains, skeins,  
warps, ball warps, cones, tubes. Sell  
direct.

**New York Mills, The**, New York Mills,  
Oneida Co., N. Y. All numbers; cones,  
tubes, skeins. Sell direct.

## COTTON MISCELLANEOUS.

### Bleached Yarns.

**Ballou Yarn Co.**, Providence, R. I.  
All numbers; warps, chains, skeins.  
Sell direct.

**Dexter Yarn Co.**, Pawtucket, R. I.  
4s to 30s; skeins, tubes, warps. Sell  
direct.

**Greene & Daniels Mfg. Co.**, Paw-  
tucket, R. I. 8s to 80s; chains, skeins,  
ball warps. Sell direct.

**Hampton Co.**, East Hampton, Mass.  
Sell direct.

**Indian Orchard Co.**, Indian Orchard,  
Mass. All numbers; chains, skeins,  
ball warps, etc. Sell direct.

**Lorimer's, W. H. Sons & Co.**, Ontario  
and Lawrence Sts., Phila., Pa. 2s to  
150s; two ply, skeins. Sell direct.

**Tucker & Cook Mfg. Co.**, Conway,  
Mass. 8s to 20s; cones, tubes, skeins,  
warps. Sell direct.

**Utica Steam and Mohawk Valley  
Cotton Mills**, Utica, N. Y. All num-  
bers; skeins, cones, tubes. Sell direct.

**Walcott & Campbell Spinning Co.**,  
New York Mills, N. Y. All numbers;  
cops, cones, skeins. Sell direct.

**Whittier Mills**, Springfield, Mass. 2s  
to 40s; warps, beams, ball warps. Sell  
direct.

### Glazed and Polished.

**Ballou Yarn Co.**, Providence, R. I.  
All numbers; warps, chains, skeins.  
Sell direct.

**Blodgett & Orswell Co.**, Pawtucket,  
Fine numbers. Sell direct.

**Boaz Thread Co.**, Stamford, Conn. 20s to  
50s; spools. Sell direct.

**Celeste Cotton Mills**, Celeste, Texas. 20s  
to 40s; skeins, spools, ball warps. Sell  
through agts.

**Greene & Daniels Mfg. Co.**, Paw-  
tucket, R. I. 8s to 80s; chains, skeins,  
ball warps. Sell direct.

**Holmes, John C. & Co.**, SpringfieM,  
Vt. 12s to 26s; skeins, dresser spools,  
beams, warps. Sell direct.

**Malcolm Mills Co.**, Frankford, Phila.,  
Pa. All numbers; skeins, spools, warps.  
Sell through Phila. office.

**Wadsworth Braiding Co.**, Providence, R.  
I. All numbers. Sell direct.

**Warren Thread Works, W.**, Westfield,  
Mass. 6s to 30s; cones, tubes, skeins,  
dresser spools. Sell direct.

**Whittier Mills**, Springfield, Mass. All  
numbers; skeins, chains, ball warps,  
spools. Sell direct.

### Gassed Yarn.

**Ballou Yarn Co.**, Providence, R. I.  
All numbers; warps, chains, skeins.  
Sell direct.

**Greene & Daniels Mfg. Co.**, Paw-  
tucket, R. I. 8s to 80s; chains, skeins,  
ball warps. Sell direct.

**Lorimer's, W. H. Sons & Co.**, Ontario  
and Lawrence Sts., Phila., Pa. 2s to  
150s; 2 ply, skeins. Sell direct.

**Warren, W.**, Thread Works, Westfield,  
Mass. Sell direct.

# INDIAN ORCHARD COMPANY.

E. MORGAN, Pres.  
H. K. WIGHT, Treas.  
W. C. GODFREY, Agt.

Indian Orchard,  
Massachusetts.

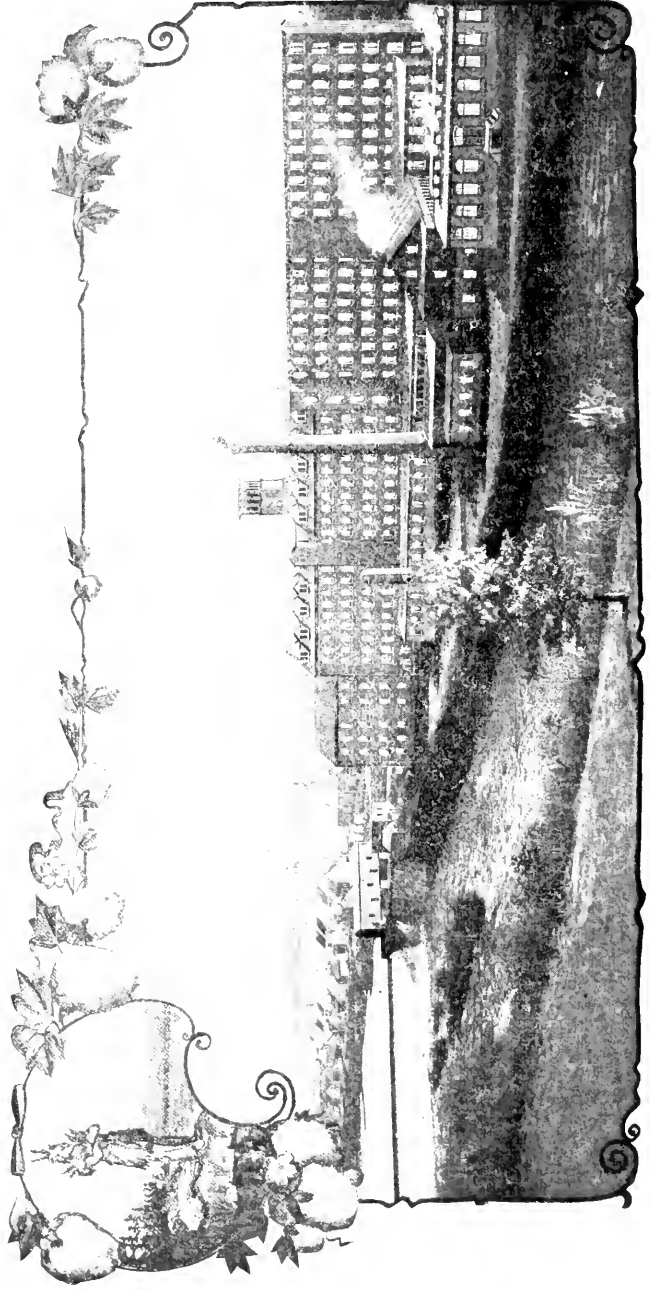

## Carded and Colored Cotton

For mixing with Wool, Machined or in Roving.

## Cotton Warps and Yarns

In Grey and all Colors, Single or Two or more Ply, and Cable Cord.

## Novelty Yarns

In various Patterns, Colors and Twist.

**Novelty Yarns.**

**Binn's Patent Band Co.**, 5th and Berks Sts., Phila., Pa. All numbers. Sell direct.

**Greene & Daniels Mfg. Co.**, Pawtucket, R. I. All numbers, any form. Sell direct.

**Indian Orchard Co.**, Indian Orchard, Mass. All numbers; skeins, beams, bobbins. Sell direct.

**Malcolm Mills Co.**, Frankford, Phila., Pa. All numbers; skeins, spools, warps. Sell through Phila. office.

**Montgomery Co., The J. R.**, Windsor Locks, Conn.

**Whittier Mills**, Springfield, Mass. All numbers; spools, skeins. Sell direct.

**Ashaway Line & Twine Mfg. Co.**, Ashaway, R. I. Sell direct.

**Bibb Mfg. Co.**, Macon, Ga. Sell direct.

**Brownell & Co.**, Moodus, Conn. Sell direct.

**California Cotton Mills Co.**, Oakland, Cal. Sell direct.

**Catawba Electric Power Co.**, Mountain Island, N. C.

**Central Mills Co.**, Southbridge, Mass.

**Dexter Yarn Co.**, Pawtucket, R. I. Sell direct.

**Draper, S., & Son**, Troy, N. Y.

**Estes, J. H., & Sons**, Fall River, Mass.

**Fricke, J. E., Co.**, Hulmville, Pa. Sell direct.

**Goss Bros.**, Bedford St., Fall River, Mass. Sell direct.

**Green, A., & Co.**, Baltimore, Md.

**Greene & Daniels Mfg. Co.**, Pawtucket, R. I. Sell direct.

**Indian Orchard Co.**, Indian Orchard, Mass. All numbers; cable twist, any ply, skeins. Sell direct.

**Johnson, J. S., Co.**, Baltimore, Md.

**Kansas Cotton Mill Co.**, The, Independence, Kas.

**Lees Mfg. Co.**, Westport, Conn. Sell direct.

**Lord, R. W., & Co.**, Kennebunk, Me., New York Net & Twine Co., Moodus, Conn. Sell direct.

**Phoenix Cotton Mills**, Nashville, Tenn. Twines. Sell direct.

**Purple, A. E.**, Moodus, Conn. Sell direct.  
**Rope & Yarn Mills**, Tuscaloosa, Ala. Sell direct.

**Tallassee Falls Mfg. Co.**, Montgomery, Ala. Sell direct, and **J. Spencer Turner Co.**, N. Y. s. agts.

**Thomas Cotton Mills**, Little Rock, Ark. Schemerhorn Bros. & Co. s. agts.

**Tucker & Cook Mfg. Co.**, Conway, Mass. All sizes; balls, tubes. Sell direct.

**Tuscaloosa Mills**, Tuscaloosa, Ala. Sell direct.

**Wheaton, Simeon A.**, Phoenixville, Conn.

**Whittier Mills**, Springfield, Mass. Special colored drug twines; tubes, balls, skeins. Sell direct.

**Printed Yarn.**

**Montgomery Co., The J. R.**, Windsor Locks, Conn. 1s to 40s; spools, skeins, warps. Sell direct.

**Seaming Yarn.**

**Dexter Yarn Co.**, Pawtucket, R. I. 4s to 30s; skeins, tubes. Sell direct.

**Greene & Daniels Mfg. Co.**, Pawtucket, R. I. Sell direct.

**Warren, W.**, Thread Works, Westfield, Mass. All numbers, any form. Sell direct.

**Tinsel Yarn.**

**Binns Patent Band Co.**, 5th and Berks Sts., Phila., Pa. All numbers. Sell direct.

**Malcolm Mills Co.**, Frankford, Phila., Pa. All numbers; spools. Sell direct.

**Montgomery Co., The J. R.**, Windsor Locks, Conn. All numbers; spools. Sell direct.

**Twine.**

**American Net & Twine Co.**, Anniston, Ala. Sell direct.

**Andrews, Albert J., Anthony, R. I.** Sell direct.

**A. D. SALKELD & BRO.**

With Fred'k Vietor & Achelis.

**— Y A R N S, —**

66-72 Leonard Street. NEW YORK.

**Eddy & Street,**

**YARNS AND BRAIDS,**

COTTON, WOOLEN, WORSTED, SPUN SILK.

**PROVIDENCE, - R. I.**

## WOOLEN YARN.

### Belgian System, Fine Counts.

- Falls Yarn Mills, Woonsocket, R. I. 2 to 10 Rs.; skeins. Sell direct.
- Fling's, Joseph, Sons, Wister St., Germantown, Phila., Pa. Fine counts; cops, skeins. Sell direct.
- Guerin Spinning Co., Woonsocket, R. I. Fine yarns; cops, skeins. Sell direct.
- Randall, Joseph, & Bro.**, 103 East Sharpnack St., Station G, Germantown, Phila., Pa. 8 to 40 cuts; tubes, skeins. Sell direct.
- River Spinning Co., Woonsocket, R. I. Fine counts; cops, spools. Sell direct.

### Merino Yarn.

- Beswick, Samuel, 25th and Callowhill Sts., Phila., Pa. 16 to 35 cut; cops, spools. Sell direct.
- Boyer, B. F. Co.**, Camden, N. J. 1 to 10 Rs, two, three and four ply; cops, bobbins, spools. Sell direct.
- Broadbent, J., & Son**, Unionville, Conn. 2 to 6 Rs; cops, skeins, spools. Sell direct.
- Eaton Rapids Woolen Mills**, Eaton Rapids, Mich. 1 to 10 Rs; cones, tubes, skeins, cops, dresser spools. Sell direct.
- Emsley, Wm., & Bro., Emerald and Adams Sts., Phila., Pa. 10 to 30 cut; cops, skeins. Sell direct.
- Fling's, Joseph, Sons, Wister St., Germantown, Phila., Pa. 6 to 36 cuts; cops, skeins. Sell direct.
- Grant, Henry, & Son, 3d and Somerset Sts., Phila., Pa. 20 to 60 cut; skeins, cops. Sell direct.
- Grayson, Geo., Darby, Pa. 5 to 30 cut; skeins. Sell direct.
- Guerin Spinning Co., Woonsocket, R. I. 2 to 8 Rs.; skeins, spools. Sell direct.
- Hamill & Co., Church Lane and Lena St., Germantown, Phila., Pa. 10 to 40 cut; skeins, cops. Sell direct.
- Holt, John P., Main St., below Shur's Lane, Manayunk, Phila., Pa. 10 to 40 cut; skeins, cops. Sell direct.

- Jowett, John W., Methuen, Mass. 1 to 10 Rs.; cops, bobbins, skeins, spools. Sell direct.
- Lafferty, M., Coral and Taylor Sts., Phila., Pa. 5 to 26 cut; skeins. A. J. Cameron & Co., Phila., s. agts.
- McGinley & Klenk, Auburn St. and Trenton Ave., Phila., Pa. 8 to 30 cut; skeins, tubes. Sell direct.
- Morris & Ott, Burnside St., Manayunk, Phila., Pa. 8 to 30 cuts; tubes, skeins, cops, backwound. Sell direct.
- Perry Yarn Mills, Webster, Mass. 1 to 10 Rs.; cops, bobbins, spools, skeins. Sell direct.
- Phoenix Spinning Co., Providence, R. I. 2 to 8 Rs.; cops, skeins, spools. Sell direct.
- Pittsfield Mfg. Co., Pittsfield, Mass. 5 to 40 cut; spools, bobbins. Sell direct.
- Platt, A., & Son, Main St., Manayunk, Phila., Pa. 6 to 16 cut; skeins. Sell direct.
- Platt Bros., Main St., Manayunk, Phila., Pa. 120 yds. per oz.; skeins.
- Randall, Joseph, & Bro.**, 103 East Sharpnack St., Station G, Germantown, Phila., Pa. 12 to 46 cut; skeins. Sell direct.
- Rice, Clayton G., Howard and Huntingdon Sts., Phila., Pa. 10 to 28 cut; skeins. Sell direct.
- Ring, Jonathan, & Son, 1759 Hancock St., Phila., Pa. 6 to 50 cut; skeins. Sell direct.
- River Spinning Co., Woonsocket, R. I. 2 to 10 Rs.; skeins, spools. Sell direct.
- Rockwell, E. M.**, Leominster, Mass. 1 to 8 Rs.; cops, dresser spools, skeins. Sell direct.
- Rowe & Co., Laconia, N. H. 1 to 6 Rs.; cops, skeins. Sell direct.
- Rutter Bros., Lawrence, Mass. 1 to 8 Rs.; colored, cops, spools. Sell direct.
- Scatchard's, Joseph, Sons, Chelton and Magnolia Aves., Germantown, Phila., Pa. 8 to 40 cut; skeins. Sell direct.
- Sheble, Frank J., E. Thompson and Division Sts., Phila., Pa. 10 to 40 cut; skeins. Sell direct.
- Thomas, H. B., 3d, below Ontario St., Phila., Pa. 10 to 40 cut; skeins. Sell direct.
- Wood, Sam'l, 109 Jefferson St., Germantown, Phila., Pa. 12 to 36 cut; cops, colored and white. Sell direct.

### FRANKLIN YARN MILL.

## J. Randall & Bro.

Woolen and Merino Yarns for  
Warp and Filling, also colored  
Yarns and Mixes. . . . .

**Belgian System.**

Germantown, Phila., Pa.

### Woolen Warp and Filling.

- Bartlett, H. O., Harmony, Me. 1 run to 6 run; spools, cops. Sell direct.
- Boyer, B. F. Co.**, Camden, N. J. 1 to 10 Rs., two, three and four ply; cops, spools, bobbins. Sell direct.
- Broadbent, J., & Son**, Unionville, Conn. 2 to 6 Rs.; skeins, cops, spools. [Yarns for knitting and weaving. Three sets of wide cards. Pickers and lappers. Long experience. Light expenses. Low prices.] Sell direct.
- Catawba Woolen Mills, Plateau, N. C. 6 to 16 cuts; skeins, cops. Sell direct.

- Dearnley, John H., 8th and Somerset Sts., Phila., Pa. 35 cut and coarser; skeins, cops. Sell direct.
- Dobson, John, West Manayunk, Phila., Pa. 30 cut and coarser; skeins. Sell direct.
- Eaton Rapids Woolen Mills,** Eaton Rapids, Mich. 1 to 10 Rs.; cones, tubes, skeins, cops, dresser spools. Sell direct.
- Keystone Spinning Mills Co., 1631 North Second St., Phila., Pa. 3 to 25 cuts; skeins, cops, bobbins. Sell direct.
- Leicester & Continental Mills, Lena and Armat Sts., Germantown, Phila., Pa. 6 to 30 cut; cops, skeins. Sell direct.
- Lord, John, Sons, 2323 Terrace St., Manayunk, Phila., Pa. Coarse numbers; skeins. Sell direct.
- Pittsfield Mfg. Co., Pittsfield, Mass. 5 to 40 cut; skeins, cops, spools. Sell direct.
- Randall, Joseph, & Bro.,** 103 East Sharpnack St., Station G., Germantown, Phila., Pa. 8 to 40 cuts; tubes, skeins. Sell direct.
- Ridley Mill, Clifton Heights, Pa. 10 to 20 cut; skeins. Sell direct.
- Rinehart, H. P., Adams and Emerald Sts., Phila., Pa. 10 to 30 cuts; tubes, skeins, cops. Sell direct.
- Rockwell, E. M.,** Leominster, Mass. 1 to 10 Rs.; cops, skeins, dresser spools. Sell direct.
- Shaw & Bowen, Main St., foot Washington, Manayunk, Phila., Pa. 8 to 26 cut; skeins. Sell direct.
- Whitney, Geo., Woolen Co., Otter River, Mass. 1 to 6 Rs.; tubes, cones, dresser spools. Sell direct.
- Clegg, Thos., & Co., Ardmore, Pa. 2 to 30 cut; cops, skeins. Sell direct.
- Davis, W. S., Main St., Manayunk, Phila., Pa. 120 yds. per oz.; skeins. Sell direct.
- Humphreys, Seth, Gladwyne, Pa. 40 to 60 yds. per oz.; skeins. Sell direct.
- Johnson, J. Wesley, Emerald St. and Allegheny Ave., Phila., Pa. Skeins. Sell direct.
- Krook & Bruch Co., The, Emerald and Adams Sts., Phila., Pa. 40 to 60 yds. per oz.; skeins. Sell direct.
- Stafford & Co., Krams Ave., Manayunk, Phila., Pa. 40 to 60 yds. per oz.; skeins. Sell direct.
- Sykes Bros., 2080 East Dauphin St., Phila., Pa. Wool and jute mixed skeins. Sell direct.
- Thornton, Wm., 1214 Crease St., Phila., Pa. 40 to 60 yds. per oz.; skeins. Sell direct.
- Whitaker, J., & Bro., Trenton Ave. and Sargent St., Phila., Pa. Skeins. Sell direct.

### Carpet Yarn, Double Reel.

- Barber, Geo., Allegheny and Kensington Aves., Phila. Sell direct.
- Ford, W. & R., Tacony St. and Penn. R. R., Frankford, Phila., Pa. 120 yds. per oz.; skeins. Sell direct.
- Gardner, John, & Son, Madison St. and Kensington Ave., Phila., Pa. Skeins. Sell direct.
- Hey, David, Germantown, Phila., Pa. Skeins, cops. Sell direct.
- James, G. L., Walnut and Lauriston Sts., Manayunk, Phila., Pa. Skeins. Sell direct.
- Johnston Bros., Leverington Ave. and Wilde St., Manayunk, Phila., Pa. Skeins. Sell direct.
- Johnson, Jos., Allegheny and Kensington Aves., Phila., Pa. Skeins. Sell direct.
- Jones, Newton, Limekill Pike, below Chelton Ave., Germantown, Phila., Pa. 120 yds. per oz.; skeins. Sell direct.
- Kerkeslager, Irvin C., Leverington Ave. and Wilde St., Manayunk, Phila., Pa. 40 to 60 yds. per oz.; skeins. Sell direct.
- Keystone Spinning Mills Co., 1631 North Second St., Phila., Pa. All numbers. Delivered in any form. Sell direct.
- Lee, James H., Emerald and Willard Sts., Phila., Pa. 40 to 60 yds. per oz.; skeins. Sell direct.
- Lodge, John F., & Sons, Hart Lane and Emerald St., Phila., Pa. 40 to 120 yds. per oz.; skeins. Sell direct.
- Morris, E. H., Walnut Lane and Free-land Ave., Manayunk, Phila., Pa. 5-8 and super; skeins. Sell direct.
- Scholes, Wm., & Son, 2d and Indiana Sts., Phila., Pa. Skeins. Sell direct.
- Somerset & Co., Wilde St. and Leverington Ave., Manayunk, Phila., Pa. 40 to 60 yds. per oz.; skeins. Sell direct.
- Thornton, Uriah, Madison and Kensington Aves., Phila., Pa. Skeins. Sell direct.

### Colored Woolen Yarns and Mixes.

- Boyer, B. F. Co.,** Camden, N. J. 1 to 10 Rs., two, three and four ply; cops, skeins, bobbins. Sell direct.
- Eaton Rapids Woolen Mills,** Eaton Rapids, Mich. 1 to 10 Rs.; cones, tubes, skeins, cops, dresser spools. Sell direct.
- Randall, Joseph, & Bro.,** 103 East Sharpnack St., Station G., Germantown, Phila., Pa. 8 to 40 cuts; tubes, skeins. Sell direct.
- Rockwell, E. M.,** Leominster, Mass. 1 to 10 Rs.; dresser spools, cops, skeins. Sell direct.
- Tillotson Mfg. Co., Pittsfield, Mass. 1 to 10 Rs.; cops, bobbins, cones. Sell direct.
- Whitney Woolen Co., So. Royalston, Mass. 1 to 10 Rs.; cops, bobbins, spools, cones. Sell direct.

### Carpet Yarn, Single Reel.

- Adams, Joseph M., Arcola Mills, Manayunk, Phila., Pa. 120 yds. per oz.; skeins. Sell direct.
- Allen, Wm., & Son, Howard St., below Lehigh Ave., Phila., Pa. 120 yds. per oz.; skeins. Sell direct.
- Baltz Bros., Main St., Manayunk, Phila., Pa. 120 yds. per oz.; skeins. Sell direct.
- Barber, E. L., Bridgeport, Pa. Skeins. Sell direct.
- Batty's, Job, Sons Co., Emerald and Adams St., Phila., Pa. 200 yds. per oz.; skeins. Sell direct.



# CRANSTON WORSTED MILLS

BRISTOL, R. I.

MANUFACTURERS OF

## WORSTED AND MOHAIR YARNS,

In White, Colors and Mixtures, on Spools, Skeins, Cones or Shuttle Bobbins,

## NOVELTY YARNS.

We are the only spinners in the U. S. making these yarns of Worsted and Mohair, who make yarns only

GENAPPE YARNS IN WORSTED AND MOHAIR.

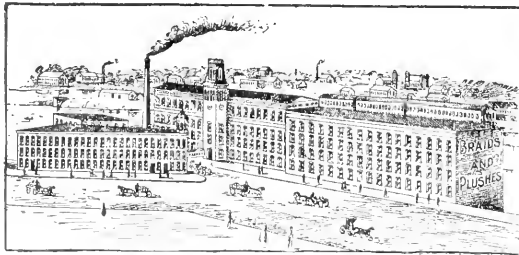

## FLYER SPUN Mohair and Worsted YARNS.

MOHAIR LININGS,  
Mohair Plushes,  
Worsted and Cotton Braids.

**D. COFF & SONS,**

ESTABLISHED 1861.

**Pawtucket, R. I.**

INCORPORATED 1881.

FRENCH SYSTEM.

BRADFORD SYSTEM

**B. F. BOYER CO.,**

Manufacturers of

## WORSTED & WOOLEN YARNS

IN WHITE  
and MIXES.

CAMDEN, N. J.

OFFICE AND MILL: Delaware and Cooper Streets.

WORSTED  
MOHAIR  
FANCY

# Yarns

**A. T. SKERRY & CO., 47 Leonard St., NEW YORK.**

Wabash Mills Co., Manayunk, Phila., Pa. Skeins. Sell direct.  
 Wilde, Jno., & Bro., Manayunk, Phila., Pa. Skeins. Sell direct.  
 Wilde's, Robt., Son, Hamilton St. and Leverington Ave., Manayunk, Phila., Pa. 45 to 120 yds. per oz. Skeins. Sell direct.

Keystone Spinning Mills Co., 1631 North Second St., Phila., Pa. All numbers. Delivered in any form. Sell direct.  
**Rockwell, E. M.**, Leominster, Mass. All numbers; skeins, cops. Sell direct.

**Rug and Fringe Yarns.**

Booth & Bro., Gladwyn, Pa. All numbers in 3 ply. Sell direct.

**Novelty Yarns.**

**Craunton Worsted Mills**, Bristol, R. I. All numbers; skeins, spools. Sell direct.  
**Rockwell, E. M.**, Leominster, Mass. All numbers; skeins, cops, dresser spools; also mohair yarns. Sell direct.

**WORSTED YARNS.**

**Bradford System, Lustre Yarns.**

**Craunton Worsted Mills**, Bristol, R. I. 10s to 32s; skeins, spools. Sell direct.  
 Hodgson Bros., Camden, N. J. 12s to 40s; skeins, dresser spools. Sell direct.  
 Massachusetts Mohair Plush Co., Lowell, Mass. 10s to 34s; skeins, spools. Sell direct.  
 Philadelphia Worsted Co., 74-84 Erie St., Camden, N. J. 1s to 32s; dresser spools. Sell direct.  
**Pocasset Worsted Co.**, Thornton, R. I. 10s to 32s; spools, skeins. Sell direct.  
**Queensbury Mills**, Worcester, Mass. 1s to 40s, single or two ply; skeins, spools. Sell direct.

**Bradford System  $\frac{1}{4}$  to  $\frac{3}{8}$  Blood.**

Abbott Worsted Co., Graniteville, Mass. 1s to 40s; spools, cones, skeins. J. C. Wallace, Phila., s. agt., and sell direct.  
 Arlington Mills, Lawrence, Mass. 1s to 40s; spools, skeins, tubes. Harding, Whitman & Co., N. Y., Phila., and Boston, s. agts.  
 Ball, H. C. & Co., Main St., Manayunk, Phila., Pa. 10s to 40s; skeins, spools. Thos. H. Ball, s. agt.  
**Boyer, B. F. Co.**, Camden, N. J. To 40s, two, three and four ply; dresser spools, skeins. Sell direct.  
 Cameron Worsted Co., The Emerald and Westmoreland Sts., Phila., Pa. 10s to 40s; skeins, spools. A. J. Cameron & Co., Phila., Boston, and Chicago, s. agts.  
 Centredale Worsted Mills, Centredale, R. I. 10s to 40s; spools, skeins. Sell direct.  
 Chautauqua Worsted Mills, Jamestown, N. Y. 30s to 40s; spools, skeins, tubes. Sell direct.  
 Columbia Worsted Co., Wallingford, Pa. 10s to 40s; spools, skeins. Sell direct.  
 Crabtree & Patchett, Montgomery, N. Y. 2s to 40s; tubes, skeins, dresser spools. Sell direct.  
**Craunton Worsted Mills**, Bristol, R. I. 10s to 40s; skeins, spools. Sell direct.  
 Doak, Jas., Jr., & Co., Trenton Ave., Norris and Blair Sts., Phila., Pa. 12s to 40s; spools, skeins. Sell direct.  
 Dobson, J. & J., Falls of Schuylkill, Phila., Pa. 16s to 40s; skeins, spools. Sell direct through Phila., and N. Y. offices.

Emmott Chester Worsted Co., Chester, Pa. 10s to 40s; skeins, spools. Sell direct.  
 Griswold Worsted Co., Darby, Pa. 10s to 40s; spools, skeins. Sell direct.  
 Grundy, W. H., & Co., Bristol, Pa. 10s to 40s; spools, skeins. Sell direct.  
 Herbst, Albert, & Co., S. W. cor. Allegheny Ave. and Emerald St., Phila., Pa. 10s to 40s; skeins, spools. Sell direct.  
 Hodgson Bros., Camden, N. J. 12s to 40s; skeins, dresser spools. Sell direct.  
 Hope Worsted Mills, Louisville, Ky. 1s to 40s; skeins, spools, shuttle bobbins. Chas. F. Murphy & Co., Boston, s. agts.  
 Lees, James, & Sons Co., Bridgeport, Pa. 8s to 32s; skeins, spools. Sell direct.  
**Linden Worsted Mills, Howland Craft, Sons & Co.**, Camden, N. J. 20s to 60s; skeins, spools. Sell direct.  
 Lund, Ezra, Landenburg, Pa. 10s to 40s; spools, skeins. Sell direct.  
 Lymansville Co., Lymansville, R. I. 10s to 36s; spools, skeins. Sell direct.  
 Magee Carpet Works, Ltd., The, Bloomsburg, Pa. 10s to 36s; skeins, spools. Sell direct.  
 Milwaukee Worsted Mills, Milwaukee, Wis. 10s to 40s; skeins, cones. Sell direct.  
 Moore, Geo. C., No. Chelmsford, Mass. 1s to 36s; spools, skeins. Catlin & Co., N. Y., Boston, and Phila., s. agts.  
 Nonantum Worsted Mills, Newton, Mass. 1s to 40s; spools, skeins. Sell direct.  
 Passaic Worsted Mills, The, Passaic, N. J. 1s to 36s; skeins, spools. Sell direct.  
**Pocasset Worsted Co.**, Thornton, R. I. 10s to 40s; spools, skeins. Sell direct.  
**Queensbury Mills**, Worcester, Mass. 1s to 40s; skeins, spools. Sell direct.  
 Robertsford Worsted Mills, Passaic, N. J. 1s to 36s; skeins, spools, bobbins. Simon, Israel, & Co., N. Y., s. agts.  
 Saxonville Mill, Saxonville, Mass. 8s to 36s; skeins, spools, bobbins. Sell direct through Boston office.  
 Shickshinny Worsted Mills, Shickshinny, Pa. 10s to 30s; skeins. Sell direct.  
 Shimer, Geo., Son, Camden, N. J. 10s to 36s; spools, skeins. Sell direct.  
 Springfield Worsted Mills, Bordentown, N. J. 16s to 40s; skeins, tubes, spools. Sell direct.

Stafford Worsted Co., Stafford Springs, Conn. 2-16s to 2-36s; skeins, spools. Sell direct.

Star Worsted Co., Fitchburg, Mass. 10s to 50s; skeins, cones, spools. Sell direct.

Steeer Worsted Mills, Providence, R. I. 10s to 40s; skeins, spools. Sell direct.

Straus, F. A., & Co., Chester, Pa. 12s to 40s; spools, skeins, cones. Sell direct.

Sunbury Worsted Spinning Co., Sunbury, Pa. 10s to 36s; spools, skeins. Thos. H. Ball, s. agt.

Tracy Worsted Mills Co., The, 2500 Spruce St., Phila., Pa. 10s to 40s; skeins, spools. Sell direct.

Walsh Mill, United States Bunting Co., Lowell, Mass. 1s to 36s; spools, skeins. Sell direct.

Winola Worsted Yarn Co., Tunkhannock, Pa. 10s to 36s; skeins, spools. Sell direct.

### Bradford System, Delaine-Australian Ex. Fine Quality.

Botany Worsted Mills, Passaic, N. Y. All numbers; skeins, spools, bobbins, warps. Sell direct through N. Y. office.

Boyer, B. F. Co., Camden, N. J. All numbers, two, three and four ply; dresser spools, skeins. Sell direct.

Cranston Worsted Mills, Bristol, R. I. All numbers; skeins, spools. Sell direct.

Dobson, J. & J., Falls of Schuylkill, Phila., Pa. 24s to 50s; skeins. Sell direct through Phila. and N. Y. offices.

Goff, D., & Sons, Pawtucket, R. I. 40s to 60s; skeins, spools, flyer spun. Sell direct.

Highland Worsted Mills, Camden, N. J. Fine numbers to 100s; bobbins, spools, skeins. Sell direct.

Linden Worsted Mills, Howland Croft, Sons & Co., Camden, N. J. 20s to 60s; skeins, spools. Sell direct.

Park Worsted Mill, Wm. E. Walsh, Lowell, Mass. 20s to 40s; tubes, skeins, dresser spools. Sell direct.

Pocasset Worsted Co., Thornton, R. I. 30s to 60s; spools, skeins. Sell direct.

Woonsocket Worsted Mills, Woonsocket, R. I. 10s to 70s; spools, skeins. Sell direct.

Yewdall & Jones, 54th and Poplar Sts.; Phila., Pa. 10s to 60s; skeins, spools. Sell direct.

### Bradford System, Carpet Yarns.

Bromley Bros.' Carpet Co., York and Jasper Sts., Phila., Pa. 14s to 16s; skeins, bobbins, spools. Sell direct.

Crow, Alex. Jr., 245 Ashmead St., Germantown, Phila., Pa. 10s to 20s; skeins. Sell direct.

Imperial Woolen Co., Manyunk, Phila., Pa. 12s to 16s; skeins. Sell direct.

Kentworthy, T. & Bro., Shurs Lane, Manyunk, Phila., Pa. 6s to 14s; skeins. Sell direct.

Moore, Geo. C., Westford, Mass. All numbers; skeins. Catlin & Co., N. Y. and Boston, s. agts.

### Bradford System, Fancy Mixtures.

Boyer, B. F. Co., Camden, N. J. To 40s, two, three and four ply; dresser spools, tubes. Sell direct.

Cranston Worsted Mills, Bristol, R. I. All numbers; tubes, spools. Sell direct.

Linden Worsted Mills, Howland, Croft Sons & Co., Camden, N. J. 20s to 60s; tubes, spools. Sell direct.

Queensbury Mills, Worcester, Mass. 1s to 40s, single or two ply; dresser spools. Sell direct.

### French Spun, $\frac{1}{4}$ to $\frac{3}{8}$ Blood, White or Natural.

Boyer, B. F. Co., Camden, N. J. 10s to 30s, two, three and four ply; cops, cones, tubes, spools, skeins. Sell direct.

Milwatkee Worsted Mills, Milwaukee, Wis. 10s to 40s; cops, dresser spools, skeins. Sell direct.

Wolstenholme, Thos., Sons & Co., Frankford Ave. and Westmoreland St., Phila., Pa. 20s to 40s; cops, skeins, single or two ply. Sell direct.

### French Spun, Fine Qualities.

Boyer, B. F. Co., Camden, N. J. All numbers, two, three and four ply; skeins, spools, cops. Sell direct.

Erben, Harding & Co., 2416 Spring Garden St., Phila., Pa. 10s to 70s; cops, spools, skeins. Sell direct.

Lafayette Worsted Co., Woonsocket, R. I. 20s to 60s; skeins, cops, spools. Sell direct.

Loridan Worsted Co., Providence, R. I. 15s to 50s; tubes, skeins, cops, dresser spools. Sell direct.

Merion Worsted Mills, West Conshohocken, Pa. 12s to 60s, single to three ply; cops, cones, tubes, dresser spools, skeins. Sell direct.

Runnymede Worsted Mills, Clifton Heights, Pa. 20s to 50s; cops, spools. Sell direct.

Saxony Worsted Mills, Newton, Mass. 1s to 60s; cops, skeins, dresser spools. Sell direct.

Wolstenholme, Thos., Sons & Co., Frankford Ave. and Westmoreland St., Phila., Pa. 20s to 50s; cops, skeins; single or two ply. Sell direct.

### French Spun, Fancy Mixtures.

Boyer, B. F. Co., Camden, N. J. To 40s, two, three and four ply; dresser spools, tubes. Sell direct.

Loridan Worsted Co., Providence, R. I. 15s to 50s; tubes, skeins, cops, dresser spools. Sell direct.



**Wolstenholme, Thos., Sons & Co.,**  
Frankford Ave. and Westmoreland St.,  
Phila., Pa. 20s to 80s; cops, single or  
two ply. Sell direct.

**French Spun, Worsted and Cotton  
Mixtures.**

**Boyer, B. F. Co.,** Camden, N. J.  
All numbers, two, three and four ply;  
cops, skeins, tubes. Sell direct.

**Wolstenholme, Thos., Sons & Co.,**  
Frankford Ave., Phila., Pa. All num-  
bers; cops, cones, spools. Sell direct.

**Wolstenholme & Clark, Baker and Mal-  
lory Sts., Manayunk, Phila., Pa. 13s to  
70s; cops, skeins, cones. Sell direct.**

**Worsted Boucle and Bourette.**

**Binns' Patent Band Co.,** 5th and Berks  
Sts., Phila., Pa.

**Cranston Worsted Mills, Bristol, R. I.**  
All numbers; skeins, spools. Sell direct.

**Indian Orchard Co., Indian Orchard,  
Mass.** All numbers; cones, skeins,  
jack spools. Sell direct.

**Malcolm Mills Co., Frankford, Phila.,  
Pa.** All numbers; skeins, spools, warps.  
Sell through Phila. office.

**Queensbury Mills, Worcester, Mass.**  
All numbers; skeins, spools. Sell di-  
rect.

**Worsted Genapped Yarns.**

**Bradford Mills, John & Jas. Dobson,  
Stenton and Godfrey Sts., Germantown,  
Pa. 10s to 32s; skeins, spools. Sell di-  
rect.**

**Cranston Worsted Mills, Bristol, R. I.**  
All numbers; skeins, spools.

**Malcolm Mills Co., Frankford, Phila.,  
Pa.** All numbers; skeins, spools, warps.  
Sell through Phila. office.

**Queensbury Mills, Worcester, Mass.**  
1s to 40s, single or two ply; skeins,  
spools. Sell direct.

**Mohair Yarns.**

**Boyer, B. F. Co., Camden, N. J.**  
To 40s, two, three and four ply; dresser  
spools, skeins. Sell direct.

**Cranston Worsted Mills, Bristol, R. I.**  
10s to 32s; skeins, spools. Sell direct.

**Goodall Worsted Co., Sanford, Me. 20s to  
32s; skeins. Sell direct.**

**Massachusetts Mohair Plush Co., Lowell,  
Mass. 10s to 34s; skeins, spools. Sell  
direct.**

**Regal Worsted Mills, Providence, R. I.**  
1s to 36s; skeins, spools. Sell direct.

**Queensbury Mills, Worcester, Mass.**  
1s to 40s; skeins, spools. Sell direct.

**RICHARD CAMPION,  
SELLING AGENT**

FOR

**Bristol Worsted Mills,  
Highland Worsted Mills.**

17 BANK STREET,

PHILADELPHIA, - PA.

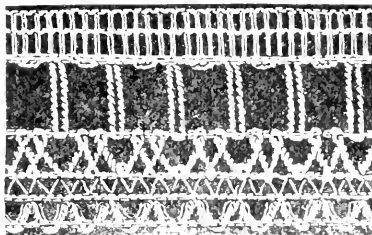

GERMANTOWN

**Lace and Edging Works**

F. A. BYRAM.

Lena St. and Church Lane, Germantown, Pa.  
George W. Chase, Art. 229 Church St., Phila.

**E. G. HARPER,**

**Worsted and Woolen Yarns, Mercerized Cotton.**

395 BROADWAY, NEW YORK.

Telephone, 1828 Franklin.

**LINEN YARN IMPORTER,**

Hughes Fawcett, 115 Franklin Street, New York.

**FLAX, HEMP and JUTE LINE and TOW YARNS,**

Linen Jacquard Harness Twines. For Cotton Harness and Heddle Twines.

For Cotton, Silk, Woolen and Carpet Manufacturers. Correspondence solicited. Samples promptly furnished.

## MISCELLANEOUS.

### Spun Silk Yarns.

**Champlain Silk Mills**, Whitehall, N. Y. All numbers; skeins, warps, cones, tubes, cops, natural or dyed. Sell direct.

**Cheney Bros.**, So. Manchester and Hartford, Conn. All numbers; skeins, spools, cones. Sell through N. Y., Boston and Chicago offices.

**Ryle, Wm. & Co.**, Newton Mills, Newton Upper Falls, Mass. Sell direct, 54 Howard St., N. Y.

### Silk Noil and Colored Yarns.

**Champlain Silk Mills**, Whitehall, N. Y. All numbers; skeins, warps, cones, tubes, cops, natural or dyed. Sell direct.

**Cheney Bros.**, So. Manchester and Hartford, Conn. All numbers; skeins, spools, cones. Sell through N. Y., Boston and Chicago offices.

## SPUN SILK

AND

## Schappe Yarns,

Also Linen, Jute and Ramie Yarns.

## H. DE VEER,

Wool Exchange Bldg. New York.

**Indian Orchard Co.**, Indian Orchard, Mass. Silk novelty yarn. All numbers; cones, tubes, etc. Sell direct.

**Malcolm Mills Co.**, Frankford, Phila., Pa. All numbers; skeins, spools, warps. Sell through Phila. office.

**Rockwell, E. M.**, Leominster, Mass. All numbers; skeins, cops, dresser spools. Sell direct.

**Ryle, Wm. & Co.**, Newton Mills, Newton Upper Falls, Mass. Sell direct, 54 Howard St., N. Y.

North Andover Silk Wiping Cloth Mfg. Co., No. Andover, Mass. All low counts. Sell direct.

### Linen Yarns and Twine.

Aransea Mfg. Co., Bristol St., near Germantown Ave., Phila., Pa. 4 to 20 lea; tubes, skeins. Sell direct.

Bable Flax Mills, 52 Leonard St., New York City; mill at Schaghticoke, N. Y. Linen yarns. Sell direct.

California Flax Mill, Oakland, Ca.

Dunbarton Flax Spinning Co., Greenwich, N. Y. The Linen Thread Co., s. agts. Linen yarns. Sell direct.

Grafton Flax Mill, Finlayson, Bonsfield & Co., Ltd., No. Grafton, Mass. The Linen Thread Co., Boston and N. Y. s. agts.

Hooven & Allison Co., Xenia, Ohio. Twine. Sell direct.

Marshall & Co., Newark, N. J. All numbers. Sell direct.

Miamisburg Twine & Cordage Co., Miamisburg, O. Twine. Sell direct.

## WM. M. YOUNG.

Manufacturers of

Worsted Spindle Tapes, Cotton Mule Banding, Hook Bands and Hooks of Every Description. Single and Double Loop Bands for Mule and Cotton Spinning Frames.

Office and Factory: 2421 23 MASCHER STREET.

Factories: 1 3638 40 Frankford Ave.  
2 3681 33 35 37 39 Emerald St.

PHILADELPHIA, PA.



CELEBRATED PYRAMID BRAND

## LACINGS

For Underwear, Overshirts and Sweaters,

JOHN CATHCART & CO., - 115 Franklin St.,

NEW YORK.

**H. L. TEBBETS & CO.,**

LOCKE'S MILLS, ME.

Thread  
and  
Silk

**SPOOLS** of any  
description,

We are located in the best white birch region. Our work and prices seem to satisfy the most particular customers. We can give any finish desired. Estimates furnished on samples submitted.

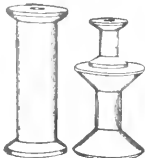



# SPUN SILK YARNS

FOR ALL PURPOSES.

BOTH IN THE

**NATURAL OR DYED,**

In Hank or Warp, or Cones, Tubes, Cops, Etc.,

**ALSO SILK NOILS.**

Special Yarns made to order for all kinds of mixed goods.

**FAST COLORS A SPECIALTY.**

MAIN OFFICE AT MILL.

Long Distance Telephone.

Moore, C. & Co., 500 Market St., Phila., Pa. Skeins. Sell direct.

Nebraska Binder Twine Co., Fremont, Neb. Twine. Sell direct.

Shrewsbury Mills, Newark, N. J. All numbers. The Linen Thread Co., N. Y., s. agts.

Smith & Dove Mfg. Co., Andover, Mass. Yarns and twines. Sell direct.

West End Thread Co., Millbury, Mass. Linen yarns. Dean, Chase & Co., Boston, s. agts.

Worcester Thread Co., Worcester, Mass. 3 to 30 lea. Sell direct, and Lock Bros., Boston, s. agts.

## Jute Yarn and Twine.

Allentown Spinning Co., Allentown, Pa. 5 hks. and above; cones, tubes, skeins, cops. The Linen Thread Co., N. Y., s. agts.

American Mfg. Co., Brooklyn, N. Y. Twine.

Chelsea Jute Mills, 1155 Manhattan Ave., Brooklyn, N. Y. Carpet yarns. Sell direct.

Columbian Cordage Co., Auburn, N. Y. Deering, Harvester Co., Chicago, Ill.

Dolphin Jute Mills, Paterson, N. J. All numbers; cones, tubes, skeins, cops. Sell direct through N. Y. office.

Fitler, Edwin H., 22 N. Delaware Ave. and Bridesburg, Phila., Pa. Twines. Sell direct.

Galveston Rope Co., Galveston, Tex. Twines. Sell direct.

Good, John & Jennings Patent Machine Cordage Co., 307 Park Ave., Brooklyn, N. Y. Twine.

Hall, Henry, Highland Mills, N. Y. Twines.

Hart, The A. H. Co., 550 West 57th St., N. Y. City. Twine.

Hodson, John M., Markle and Cresson Sts., Manayunk, Phila., Pa. Twine. Sell direct.

Jackson, Thos. & Son, Reading, Pa. Twine. Sell direct.

Jacobs Cordage Co., The, Cincinnati, O. Twine. Sell direct.

Kelly, R. A., Co., Xenia, Ohio.

Ludlow Mfg. Co., Ludlow, Mass. C. N. Wallace, 133 Essex St., Boston, s. agt.

McCormick Harvesting Machine Co., Chicago, Ill.

New Bedford Cordage Co., New Bedford, Mass.

Overman & Schrader Cordage Co., The, Cincinnati, Ohio.

Planet Mills Mfg. Co., 355 Carroll St., Brooklyn, N. Y. Yarns. Sell direct.

Rauschenberger, John, Co., Milwaukee, Wis. Twines. Sell direct.

St. Louis Cordage Co., St. Louis, Mo. Sell direct.

Sutherland & Edwards Co., Paterson, N. J.

**BUCKINCHAM, PAULSON & CO.,**  
Commission Merchants.

**Cotton Yarns of all Descriptions.**

83 LEONARD STREET, NEW YORK.

120 Chestnut Street,  
 PHILADELPHIA.

530 5th Avenue,  
 CHICAGO, ILL.

Cash Advances, Cash Sales and Prompt Returns. . . .

. . . Consignments and Correspondence Solicited.

**James E. Mitchell & Co.,**

**Commission Merchants.**

**COTTON YARNS**

**FOR ALL PURPOSES.**

122-124 Chestnut St.,  
 PHILADELPHIA, PA.

Brown Building, 185 Summer St.,  
 BOSTON, MASS.

Incorporated 1899.



Long Distance Telephone,  
 Oxford 1120.

**AMERICAN**

**Cotton Yarn Exchange**

COMBED AND CARDED COTTON YARNS

From Northern and Southern Mills,

American, Egyptian, Peruvian and Sea Islands.

ARNOLD B. SANFORD, Pres. and Gen. Mgr.

OFFICES : { 67 Chauncy St., Boston.  
 240 Chestnut St., Philadelphia.  
 108 Franklin St., N. Y. with James Talcott.

O. S. HAWES & BRO.,  
 Fall River, Mass.  
 108 Bedford Street.

RICHARD A. BLYTHE,  
 Philadelphia, Pa.  
 114 Chestnut Street.

**HAWES BROS. & BLYTHE,**  
**Cotton Yarns**

Fall River, Mass. ♡ and ♡ Philadelphia, Pa.

# YARN DEALERS, COMMISSION MERCHANTS AND AGENTS.

## AMSTERDAM.

**Charles, William B.**

## BALTIMORE.

Green, Amon & Co., 5 and 7 West German St. (Cotton)

Hooper, Wm. E. & Sons, 26 S. Frederick St. (Cotton)

Schultz & Bro., 215 West German St.

## BOSTON.

Allen, Geo. F. & Co., 105 Summer St. (Silk and Cotton Thread)

**American Cotton Yarn Exchange,** 67 Chauncy St., Arnold B. Sanford, Pres. (Cotton)

American Thread Co., 112 Beach St. (Cotton and Linen Yarns and Threads)

**Catlin & Co.**, 67 Chauncy St. (Cotton)

Croll, Albert Ivins, 85 Essex St. (Cotton)

DeMauriac, P. H., 78 Chauncy St. (Cotton)

Harding, Whitman & Co., 78 Chauncy St. (Worsted, Cotton and Tops)

Kelly, Charles P., 78 Chauncy St. (Silk)

Lane, J. H. & Co., 110 Summer St. (Cotton)

Linen Thread Co., 226 Devonshire St. (Linen and Cotton Threads)

Locke Bros., 134 Lincoln St. (Flax)

Meyer, John C. & Co., 87 Summer St. (Thread)

**Mitchell, James E. & Co.**, 185 Summer St. (Cotton)

Murphy, Chas. F. & Co., 26 Chauncy St. (Worsted)

New England Cotton Yarn Co., 77 Bedford St. (Cotton)

Prendergast, J. M. & Co. (brokers), 66 State St. (Cotton)

**Riley, C. E. & Co.**, 281 Congress St. (Cotton)

Solis & Co., 179 Devonshire St.

## CHICAGO.

**Buckingham, Paulson & Co.**, 230 Fifth Ave. (See New York) (Cotton)

Holland & Webb, 269 Dearborn St. (Ramie, Cotton, Worsted, Jute, Novelty, Spun Silk and Tussah)

Lane, J. H. & Co., 237 5th Ave. (Linen, Cotton and Jute)

Putnam, Hooker & Co., 212-18 E. Third St. (See Cincinnati) (Cotton and Wool)

Straus, F. A. & Co., 237 5th Ave. (Silk, Worsted, Cotton and Tinsel)

Ulmann, Bernhard & Co., 167 Dearborn St. (Cotton, Woolen, Worsted and Fine Linen)

## CINCINNATI.

Putnam, Hooker & Co., 16 East Second St. (Cotton and Wool)

## FALL RIVER.

Durfee & Lown. (Cotton)

Hawes, O. S. & Co. (Cotton)

Remington, Clinton V. S. (Cotton)

## LOUISVILLE.

Burford, E. A. & Co., 441 W. Main St. (Cotton)

Waters, Garland & Co., 433 W. Main St. (Cotton)

## NEW YORK.

Abegg & Rusch, 94 Grand St. (Cotton, Worsted and Mohair)

**American Cotton Yarn Exchange,** Wool Exchange Bldg. (Cotton)

Appel, M., 57 Leonard St. (Worsted)

Bale & Manley, 260 W. Broadway.

Brown, James, Freeman Co., 73 Franklin St. (Cotton)

**Buckingham, Paulson & Co.**, 83 Leonard St. (See also Cincinnati) (Cotton)

Caesar, H. A. & Co., 45 Leonard St. and 20 Greene St. (Cotton and Worsted)

**Catlin & Co.**, 216 Church St. (Cotton)

Crowe, W. M., 447 Broome St. (Silk, Mohair, Alpaca, Spun Silk, Worsted, Merino, Cotton, Mercerized, Ramie and Linen)

**DeVeer, H.**, 260 W. Broadway. (Ramie, Shappe, Linen, Cotton, Mohair and Spun Silk)

Dickson, Peck & Palmer, 54 Leonard St. (Cotton)

**Dodds, J. S.**, 517 Wool Exchange Bldg. (Mercerized Cotton)

**Eichmann & Sternberg**, 530 Broadway, cor. Spring St. (Cotton, Woolen, Worsted, Mohair, Linen, Spun Silk, Tussah and Novelty Yarn)

**Fawcett, Hughes**, 115 Franklin St. (Linen)

Frankenburg, H. E., 459 Broome St. (Silk)

**Hamilton, J. H. & Co.**, 275 Church St. (Twines)

Haraing, Whitman & Co., 80 Leonard St. (Woolen, Worsted and Cotton)

Hardt, Von Bernuth & Co., 477 Broome St. (Cotton, Worsted and Silk)

**Harper, E. G.**, 395 Broadway. (Worsted and Woolen)

Holland & Webb, 487 Broadway. (Cotton, Worsted and Silk)

Hooper, Wm. E. & Sons, 74 Broad St. (Cotton)

Horstmann, Wm. H., Co., 459 Broadway. (Silk, Woolen, Cotton and Linen)

Ijams, J. T. & Co., 53 Worth St. (Cotton)

King, Alexander & Co., 43 Leonard St. (Cotton)

- Kelley, Henry C., 548 Pearl St. (Cotton Warps)
- Lane, J. H. & Co., 110 Worth St. (Linen, Cotton and Jute)
- Lees, W. Sherman, 52 Leonard St. (Twines)
- Linen Thread Co., 48 White St. (Linen)
- Lings, G. S. & Co., 480 Broom St. (Cotton)
- Logie, Alexander, 320 Broadway. (Hemp, Carpet and Jute)
- Lord, Haynes & Co., 143 Duane St. (Cotton)
- Meyer, Jos. & Co., 135 Greene St. (Silk, Mohair and Cotton)
- Moeller & Littauer**, 109 Greene St. (Silk, Worsted, Mohair, Cotton, Tinsel)
- Morgan, E. A. & Co.**, 54 Franklin St. (Woolen and Worsted)
- Nawrath, J. P. & Co., 18 Lispenard St. (Cotton)
- New England Cotton Yarn Co., 346 Broadway. (Cotton)
- Oelbermann, Demmerich & Co., Textile Bldg. (Cotton, Woolen, Worsted, Spun Silk)
- Pope, C. H. & Co., 87 Worth St. (Cotton)
- Porter Bros. & Co., 78 Worth St. (Cotton)
- Putnam, Hooker & Co., Wm. G. Judkins, mgr., 108 Worth St. (Cotton)
- Reynolds, James E., 70 Thomas St. (Cotton)
- Robinson & Son, 137 Greene St. (Cotton)
- Robinson, Hughes & Co. (Louisville) 43 Leonard St.
- Ross, Hendy P. & Co., 23 Duane Ct. (Cotton)
- Ryle, Wm. & Co.**, 54 Howard Ct. (Silk)
- Salkeld, A. D. & Bro.**, 72 Leonard St. (All Kinds)
- Skerry, A. T. & Co.**, 47 Leonard St. (Worsted, Mohair, Silk and Novelty)
- Southern Cotton Mills & Commission Co., 69 Worth St.
- Stephenson & Co., 81 Grand St. (Woolen, Mohair and Worsted)
- Taff, Alfred, 69 Mercer St., (Spun Silk, and Shappe)
- Thompson, Sidney, 260 W. Broadway. (Silk and Cotton)
- Thompson's, Nephew, Samuel & Co., 142 Duane St. (Spun Silk, Mohair, Cotton, Ramie and Shappe)
- Tyler, C. C., 71 Franklin St. (Cotton and Carpet)
- Ullman, Bernard & Co., 109 Grand St. (Cotton, Woolen, Worsted and Fine Linen.)
- Warnier, M & Co., 91-93 Mercer St. (Worsted)
- Weaver, H. S., 134 W. Broadway. (Woolen and Hair)
- Wendt, Steinhauser & Co., 23 Greene St. (Worsted)
- White, James F. & Co., 54 Worth St. (Cotton)
- Whiteside, James, 31 Wooster St. (Worsted, Jute and Silk)
- Winne, D. P. & Co., 338 Broadway. (Twines, Etc.)

## PHILADELPHIA.

- Abbott, Wm. G., 242 Chestnut St. (Cotton and Worsted)
- American Cotton Yarn Exchange**, 246 Chestnut St. (Cotton)
- American Thread Co., 1019 Filbert St. (Cotton)
- Ball, Thomas H., 236 Chestnut St. (Worsted)
- Blankenberg, R. & Co., 617 Chestnut St. (Silk and Cotton)
- Blythe, Richard A.**, 114 Chestnut St. (Cotton)
- Buckingham, Paulson & Co.**, 118 Chestnut St. (Cotton) (See New York)
- Burnley, John B., 41 Strawberry St. (Carpet)
- Cameron, A. J. & Co., 37 S. 3d St. (Cotton, Woolen and Worsted)
- Campion, Richard**, 17 Bank St. (Cotton, Woolen and Worsted)
- Catlin & Co.**, 206 Chestnut Ct. (See New York) (Cotton)
- Chapin, Geo. W.**, 229 Church St. (Cotton and Worsted)
- Coleman & Bros., 212 Chestnut St. (Worsted)
- Cope, F. H., 468 Bourse.
- Coral Mfg. Co., 692 Bourse.
- Corbett, John & Sons, 32 Bank St. (Cotton, Woolen, Worsted and Silk)
- Croll, Albert I., 241 Chestnut St. (Cotton)
- Daniel, H. M., 511 Bourse. (Cotton)
- D'Olier, Wm. & Co., 126 Chestnut St. (Cotton, Woolen and Worsted)
- Dumee, Sons & Co., 412 Provident Bldg. (Cotton)
- Eddy & Street**, 248 Chestnut St. (Cotton, Woolen, Worsted, Silk)
- Evans, Smith & Co., 132 Chestnut St. (Cotton)
- Fawcett, Hughes**, 585 Bourse. (See New York)
- Fleming, Geo. M., 1619 No. 16th St. (Cotton)
- Frier & Co., 692 Bourse.
- Friedberger Mfg. Co.**, Fisher Lane, Germantown. (Silk)
- Griswold Worsted Co., 227 Chestnut St.
- Harding, Whitman & Co., Merchants & Marine Bldg. (Worsted, Cotton and Tops)
- Hird, Samuel, 241 Chestnut St. (Woolen, Worsted and Merino)
- Hoffman, Corr & Co., 415 Market St. (Cotton)
- Hooper's Sons Mfg. Co.**, 428 Market St. (See New York) (Cotton)
- Hooper, Wm. E. & Sons, 246 Market St. (see New York.) (Cotton)

# CHENEY BROTHERS,

SILK MANUFACTURERS.

ALL KINDS OF

Knitting Silks, Ribbons AND Piece Silks,

USED FOR TRIMMING KNIT GOODS.

**TRAMS, ORGANZINES and SPUN SILKS**, in the Hank, or on Spools or Cones,  
for Manufacturers' Use. Silk for Special Purposes Made to Order.

**MILLS:** South Manchester and Hartford, Conn.

**SALESROOMS:** 477, 479 and 481 Broome Street, NEW YORK.

79 Chauncy Street, BOSTON.

186 Franklin Street, CHICAGO.

## GEORGE W. CHAPIN,

Successor to FLEMING & CHAPIN.

Braids <sup>Cotton</sup> and <sup>Worsted</sup> Tapes <sup>Cotton</sup> and <sup>Silk</sup> Yarns <sup>Cotton</sup> Warps, <sup>Etc.</sup> Threads



Use the Genuine Patented

Crochet Lace Edgings AND  
Botany Worsted Facings.

Spun Slik Braids and Yarns a Specialty.

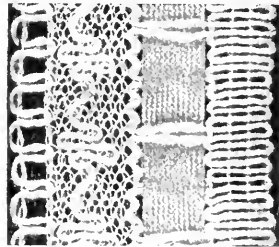

The Best Splicing Yarns  
in all Numbers,

229 - Church St. - 231  
PHILADELPHIA, PA.

## KROUT & FITE MAN'F'G CO.,

Manufacturers of SILK and COTTON

# Narrow Fabrics.

SPOOL TAPES A SPECIALTY.

Alleghany Avenue and Emerald Street, - - PHILADELPHIA, PA.  
Long Distance Telephone.

## WILLIAM B. CHARLES,

Cotton Yarn Commission Merchant,

AMSTERDAM, N. Y.

Southern Yarns for Knitting Mills a Specialty.

Mill Accounts Solicited.

- Hubbert, H. H., 203 Chestnut St. (Cotton)  
**Hyde, Edward S.**, 223 Chestnut St. (Cotton)  
 Kenworthy, T. & Bro., 111 Church St. (Cotton, Woolen and Worsted)  
 Lane, J. H. & Co., 228 Chestnut St. (Cotton)  
 Legge, Percy A., 134 Chestnut St. (Woolen, Worsted and Silk)  
 Leiper, Chas. L., 240 Chestnut St. (Cotton Woolen and Worsted)  
 Leob, Oscar D., 226 Chestnut St. (Cotton)  
 Lings, G. S. & Co., 393 Bourse. (Cotton) (See New York)  
 McCloskey, J. J., 34 N. Front St. (Wool and Cotton)  
 McCloud, Chas. M. & Co., 229 Chestnut St. (Cotton, Woolen and Worsted)  
**Malcolm Mills Co.**, Orchard, above Church St.  
**Mitchell, J. E. & Co.**, 124 Chestnut St. (Cotton, Woolen and Worsted)  
**Moore, C. & Co.**, 500 Market St. (Twines, Threads and Yarn)  
 Neall, Geo. M., 20 Strawberry St. (Jute and Linen)  
 Newcomb, 633 Bourse.  
 New England Cotton Yarn Co., 213 Chestnut St. (Cotton)  
 O'Neil, Chas., 57 No. Front St.  
 Penn Yarn Co., 320 Merchants & Marine Bldg.  
 Penny, G. F., 134 Chestnut St. (Jute)  
 Read, Wm. F., 213 Chestnut St. (Silk Warps)  
 Robb, Daniel & Co., 219 Chestnut St. (Cotton, Woolen and Worsted)  
 Schell, Taylor & Longstreth, 230 Chestnut St. (Cotton)  
 Scull, Jos. W., 215 Chestnut St. (Woolen and Worsted)  
 Seffarlen, Jos. A., 427 Market St. (Carpet)  
 Sharples, W. M. & F. W., 123 Chestnut St. (Cotton)  
 Sheble, F. J., 113 Chestnut St.  
 Southern Cotton Yarn Exchange, 304 Merchants & Marine Bldg.  
 Stephenson & Co., 240 Chestnut St. (Woolen, Worsted and Mohair)  
 Stoyle, Wilson H., 134 Chestnut St. (Cotton, Woolen, Worsted and Silk)  
 Tattersfield & Co., 33 Letitia St. (Woolen and Worsted)  
 Taylor Bros., 240 Chestnut St. (Cotton)  
 Thomas & Houston, Provident Bldg. (Cotton)  
 Thompson, Henry K., 9 Strawberry St. (Cotton and Woolen)  
 Thompson, Wm. H., 240 Chestnut St. (Cotton)  
 Tinkler & Co., 20 N. 5th St. (Cotton and Woolen)  
 Townsend, E. M., 1107 Market St. (Cotton and Woolen)  
 Wallace, J. C., 39 S. 3rd St. (Cotton, Woolen and Worsted)  
 Webb, Chas. J. & Co., 116 Chestnut St. (Cotton and Woolen)  
 White, Jas. F. & Co., 229 Chestnut St. (Cotton and Woolen)  
 Willey, J. H., 235 N. Water St. (Woolen, Merino and Mohair)  
 Wilson and Bradbury, 217 Chestnut St. (See New York) (Cotton)

## PROVIDENCE, R. I.

- Eddy & Street.** (Cotton, Woolen, Worsted and Silk)  
 Pope, C. H. & Co., 28 So. Water St.  
 Rhodes, Frank A., 20 Market Sq.  
 Shaw, Edward, 2nd, 4 Westminster St. (Cotton)  
 Taylor & Cummings. (Cotton, Woolen, Worsted, Silk)  
 Tillinghast, Stiles & Co., Industrial Trust Bldg. (Cotton)

**STARCH,**  
**DEXTRINE and GUMS.**

**STEIN, HIRSCH & CO.,**  
 169 Duane Street, NEW YORK.  
 ALSO,  
 Chicago and Philadelphia.

**THE HOLBROOK MFG. CO.**

466-470 Washington Street,

NEW YORK.

**MILL SOAPS.**



## Table of Breaking Strength of American Cotton Warp Yarns.

[By permission of the Draper Co.]

In making these tests a skein of 120 yards, or 80 turns of a 1 1-2 yard reel is used. The breaking point is given in pounds and fractions.

Number.	Breaking Weight.	Number.	Breaking Weight.	Number.	Breaking Weight.	Number.	Breaking Weight.
1.....		26.....	66.3	51.....	36.6	76.....	25.8
2.....		27.....	63.6	52.....	36.1	77.....	25.5
3.....	530.0	28.....	61.3	53.....	35.5	78.....	25.3
4.....	410.0	29.....	59.2	54.....	34.9	79.....	24.9
5.....	330.0	30.....	57.3	55.....	34.4	80.....	24.6
6.....	275.0	31.....	55.6	56.....	33.8	81.....	24.3
7.....	237.6	32.....	54.0	57.....	33.4	82.....	24.0
8.....	209.0	33.....	52.6	58.....	32.8	83.....	23.7
9.....	186.5	34.....	51.2	59.....	32.3	84.....	23.4
10.....	168.7	35.....	50.0	60.....	31.7	85.....	23.2
11.....	154.1	36.....	48.7	61.....	31.3	86.....	22.8
12.....	142.0	37.....	47.6	62.....	30.8	87.....	22.6
13.....	131.5	38.....	46.5	63.....	30.4	88.....	22.4
14.....	122.8	39.....	45.5	64.....	30.0	89.....	22.2
15.....	115.1	40.....	44.6	65.....	29.6	90.....	22.0
16.....	108.4	41.....	43.8	66.....	29.2	91.....	21.7
17.....	102.5	42.....	43.0	67.....	28.8	92.....	21.5
18.....	97.3	43.....	42.2	68.....	28.5	93.....	21.3
19.....	92.6	44.....	41.4	69.....	28.2	94.....	21.2
20.....	88.3	45.....	40.7	70.....	27.8	95.....	21.0
21.....	83.8	46.....	40.0	71.....	27.4	96.....	20.7
22.....	79.7	47.....	39.3	72.....	27.1	97.....	20.5
23.....	75.9	48.....	38.6	73.....	26.8	98.....	20.4
24.....	72.4	49.....	37.9	74.....	26.5	99.....	20.2
25.....	69.2	50.....	37.3	75.....	26.2	100.....	20.0

LONDON.GLASGOW.



“De Haven”

RING SPINNING AND  
TWISTER  
TRAVELERS.

De Haven Mfg. Co.,

50-52-54 COLUMBIA HEIGHTS,  
BROOKLYN, N. Y.

Correspondence Solicited.

## COMMISSION AND ORDER WORK.

### Wool Sorting, Scouring and Carbonizing.

Adams, J. M., Arcola Mills, Main and Centre Sts., Manayunk, Phila., Pa.

Aurora Wool Scouring Mills, Aurora, Ill.

Barlow, S. A., Dighton Waste Mill, No. Dighton, Mass.

Hecker, Chas. W., Amsterdam, N. Y.

C. L. BLANDING MFG. CO.

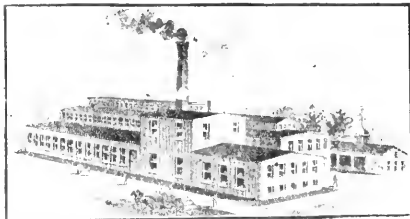

Blanding, C. L., Mfg. Co., Providence, R. I.

[Dealers in wool waste, garnetted stock and shoddy. Special attention given to custom garnetting, picking, carding, dusting, burring, scouring and carbonizing. C. L. Blanding Manager. Correspondence solicited.]

Claremont Woolen Co., Claremont, N. H.

Cleveland Wool Waste Mfg. Co., 1206 Central Ave., Cleveland, O.

Crane, R. F., West Millbury, Mass.

East Weymouth Wool Scouring Co., East Weymouth, Mass.

Erben, Harding & Co., 246 Spring Garden St., Phila., Pa.

Grover, John D. & Son, Somerset and Tulip Sts., Phila., Pa.

Hall Bros., Norwich, Conn.

Helman Godlove Mercantile Co., St. Louis, Mo.

Hudson Worsted Co., Hudson, Mass.

Keystone Spinning Co., 1631 No. 2d St., Phila., Pa.

Las Vervas Pulling Co., Las Vegas, New Mexico.

Lewis, Frank E., Lawrence, Mass.

Ludemann Wool Co., Las Vegas, New Mexico.

Molt Bros., Millbury, Mass.

Moore, Geo. C., No. Chelmsford, Mass.

Norton Mills Co., Norton, Mass.

Patchell & Eavenson, Naudoin St., Phila., Pa.

Pendleton Wool Scouring & Packing Co., Pendleton, Ore.

Philadelphia Wool Scouring & Carbonizing Co., 1818 Boston Ave., Phila., Pa.

Pluckamin Mfg. Co., Pluckamin, N. J.

River Spinning Co., Woonsocket, R. I.

Robins, John, Wool Scouring Co., Las Vegas, New Mexico.

Scott, Mrs. John, Hyde Park, Mass.

Sibley, Wm., No. Windham, Conn.

Smith, Fred S., Wilkinsonville, Mass.

The Dalles Wool Scouring Mills Co., The Dalles, Ore.

Windle, A. D. & W. W., West Millbury, Mass.

Winslow Bros., Winslow Station, Norwood, Mass.

### Worsted Tops (Carding and Combing on Commission).

Hudson Worsted Co., Hudson, Mass.

Longbottom, S. & Sons, Crum Lynne Worsted Mills, Crum Lynne, Pa.

Philadelphia Worsted Co., Elm St., Camden, N. J.

Queensbury Mills, Worcester, Mass.

Victoria Mills, Thornton, R. I.

### Wool Carding and Spinning.

Acruman, E. A., Fordyce, Ark.

Bradford Yarn Mills, Warren, Mass.

Broadbent, J. & Son, Unionville, Conn. Centre Point Woon Mills, Centre Point, Ark.

Chapman Mills, J. A. Chapman, East Putnam, Conn.

Clapp, Wm., Howard and Berks Sts., Phila., Pa.

Cline, C. A., West Branch, Mich.

Genet, John J., Jr. & Son, Leopold, Ind.

Haxton, W. B. & Co., Springdale, Ark.

Keystone Spinning Co., 1631 No. 2d St., Phila., Pa.

Lafferty & Fuller, Camptown, Pa.

Laurel Hill Yarn Co., Bridgeton, R. I.

Lebhardt, P. D., Zionsville, Ind.

Litchfield Woolen Mills, Litchfield, Minn.

Rockwell, Jno. E., Canton Wool Mills, Canton, Pa.

Rowe & Co., Laconia, N. H.

Stowell, George D., Waverly, Ia.

Thompson, A. A., Freedom, Me.

Wanita Mills Co., Enterprise, Miss.

White, O. H., Chepachet, R. I.

Wilby, J. F. & Co., Darby, Pa.

Winn, D. J. & Co., Bowman, Ga.

**Worsted Spinning From Top.**

**Allegheny Worsted Mills**, Wolstenholme, Thos., Sons & Co., Frankford Ave., and Westmoreland St., Phila., Pa.

**Cranston Worsted Mills**, Bristol, R. I.

**Croft, Howland Sons & Co.**, Broadway and Jefferson Sts., Camden, N. J.

**Boyer, B. F. Co.**, eDlaware Ave. and Cooper St., Camden, N. J.

Hodgson Bros., Camden, N. J. 16s to 40s.

Model Spinning Co., Woonsocket, R. I.

**Queensbury Mills**, Worcester, Mass.

Philadelphia Worsted Co., Elm St., Camden, N. J.

**Pocassett Worsted Co.**, Thornton, R. I.

**Rag Picking, Garnetting and Carbonizing.**

**Becker, Chas. W.**, Amsterdam, N. Y.

**Blanding, C. L. Mfg. Co.**, Providence, R. I.

**Broadbent, J., & Son**, Unionville, Conn.

Carroll Mfg. Co., Cohoes, N. Y.

Chrisman, W. N., Colemans, N. Y.

Davis, Henry A. & Sons, 143 Summer St., Providence, R. I.

Garfield Woolen Co., Garfield, N. Y.

Gray, T. H. & Co., Hyde Park, Mass.

Hitchon, W. W., Thorp Lane and 16th St., Phila., Pa.

Hudson Bros., Little Falls, N. Y.

**Hudson Fibre Co.**, Hudson, N. Y.

Klous, Henry, Methuen, Mass.

**Lowenthal, W. & Co.**, Cohoes Shoddy Mill, Cohoes, N. Y.

Mabbett, Davis & Co., Providence, R. I.

Mullineaux, Clegg & Co., Chatham Mills, Howard and Berks Sts., Phila., Pa.

Mitchell Bros., Amsterdam, N. Y.

Pease, Herbert, No. Vassalboro, Me.

Regan, Jas. J., Mfg. Co., Rockville, Conn.

**Riverdale Woolen Co.**, Northbridge, Mass.

**Slack, W. H. H. & Bro.**, Springfield, Vt.

So. Acton Woolen Co., So. Acton, Mass.

**Stoughton Mills**, West Stoughton, Mass.

Topham, Chas. H., Wister St. and P. & R. R. R., Germantown, Pa.

Walker & Williams Mfg. Co., Cohoes, N. Y.

Weeks, F. D., Extracting Co., Shirley, Mass.

**Windle, A. D. & W. W.**, West Millbury, Mass.

Wallace, J. H. & Bro., 1620 Lombard St., Phila., Pa.

**Shoddy Dusting and Lumping.**

**Becker, Chas. W.**, Amsterdam, N. Y.

**Blanding, C. L. Mfg. Co.**, Providence, R. I.

Davis, Bottom & Co., No. Wilbraham, Mass.

East Weymouth Wool Scouring Co., East Weymouth, Mass.

Gibson, E. G., East Brookfield, Mass.

**Hudson Fibre Co.**, Hudson, N. Y.

Norton Mills Co., Norton, Mass.

Peace, Herbert, North Vassalboro, Me.

Pluckamin Mfg. Co., Pluckamin, N. J.

**Stoughton Mills**, West Stoughton, Mass. Sell direct.

**Windle, A. D. & W. W.**, West Millbury, Mass.

Worcester Dusting Mill, Worcester, Mass.

Wyman, L. J., Smithfield, Me.

**Waste, Dyeing and Carbonizing.**

**Becker, Chas. W.**, Amsterdam, N. Y.

**Blanding, C. L. Mfg. Co.**, office 4 Exchange Pl., Providence, R. I.

Bower's, Jas., Sons, Ltd., Chester, Pa.

Dexter Dyeing & Carbonizing Works, Main St. and Shurs Lane, Manayunk, Pa.

**Hudson Fibre Co.**, Hudson, N. Y.

**Lowenthal, W. & Co.**, Cohoes, N. Y.

Mendon Woolen Mills, Mendon, Mass.

Millbury Scouring Mill, West Millbury, Mass.

New England Dusting Mill, Grafton St., Worcester, Mass.

Regan, Jas. J., Mfg. Co., Rockville, Conn.

**Riverdale Woolen Co.**, Northbridge, Mass.

Shuttleworth, H. L., 146 West Main St., Amsterdam, N. Y.

Simister, Chas. R., Picton Mills, Manayunk, Pa.

**Slack, W. H. H. & Bro.**, Springfield, Vt.

So. Acton Woolen Co., So. Acton, Mass.

Spink, Wm., Scotia Mills, Manayunk, Pa.

Townsend, E. A. & Co., Main St. and Walnut Lane, Manayunk, Pa.

Wallin & Nolan, Amsterdam, N. Y.

**Windle, A. D. & W. W.**, West Millbury, Mass.

Witbeck & Cunningham Bros., Mechanicsville, N. Y.

**Winding, Warping, Spooling and Beaming.**

Bank, A. M., 105 Mercer St., New York, N. Y.

Crossland's, Enos, Sons, 69th and Haverford Ave., Phila., Pa.

Dawson, J. & E., Huntington Ave. and Huntington St., Phila., Pa.

Elston, Wm. J., Ryerson Ave., Paterson, N. J.

Gill, Thos. & Son, York and Waterloo Sts., Phila., Pa.

Jenkinson, A., Paterson, N. J.  
 Martin, Chas. N., Co., 348 Canal St., New York, N. Y.  
 Pond Lily Warp Co., The, New Haven, Conn.  
 Watson, Hugh, Paterson, N. J.  
**Whittier Mills**, Springfield, Mass.  
**Wolfenden, R. & Sons**, Attleboro, Mass.

#### Skein Winding and Coning.

**Ballou Yarn Co.**, Providence, R. I.; also twisting.

**Wolfenden, R. & Sons**, Attleboro, Mass. Spooling and jack spooling.

#### Warp Sizing and Finishing.

Bartlett, Edwin, No. Oxford, Mass.  
 Green, J. C., Southgate St., Worcester, Mass.  
**Indian Orchard Co.**, Indian Orchard, Mass.  
 Pond Lily Warp Co., The, New Haven, Conn.  
**Whittier Mills**, Springfield, Mass.  
**Wood Dyeing Co., The Peter**, Worcester, Mass.

## BLEACHING, DYEING, PRINTING AND FINISHING.

### Wool Dyeing and Carbonizing (Raw Stock).

**Blanding, C. L. Mfg. Co.**, Providence, R. I.  
**Cohoes Dye Works, Duncan & Bailie**, Cohoes, N. Y.

Conway, R. W., Canton, N. Y.

**Firth & Foster Co.**, Providence Dyeing and Finishing Works, Emerald and York Sts., Phila., Pa.

Littlewood, G. J. & Sons, Ltd., Albion Dye and Bleach Works, Main St., Manayunk, Pa.

Mackintosh, D. & Sons Co., Holyoke, Mass.

**Molt Bros.**, Millbury, Mass.

River Spinning Co., Woonsocket, R. I.

**Windle, A. D. & W. W.**, West Millbury, Mass.

Wissahichon Dye Works, 8th and Cherry Sts., Camden, N. J.

### Woolen and Worsted Skein Yarn Dyeing.

Berges, J. & Co., 223 Amber St., Phila., Pa.

**Brophy's, T. Sons**, Jasper, above Clearfield St., Phila., Pa.

**Burton, Andrew**, Penn St. and Bel- field Ave., Phila., Pa.

Columbia Dye Works, 167 Columbia Ave., Phila., Pa.

**Cranston Worsted Mills**, Bristol, R. I.  
 Dawson, Thos. & Co., Amber, near Somerset St., Phila., Pa.

Diller, E. J., Columbia Dye Works, Columbia Ave., Phila., Pa.

Doak's, Jno., Sons, Front, above Huntington St., Phila., Pa.

Etchler, A. & Co., Vienna Dye Works, 1736 Mascher St., Phila., Pa.

Essex Dye Works, Lawrence, Mass.

**Firth & Foster Co.**, Providence Dyeing and Finishing Works, Emerald and York Sts., Phila., Pa.

Fitch, Samuel, Mfg. Co., Providence, R. I.  
 Flower City Dye Works, Rochester, N. Y.  
**Forrest, John, American Yarn Print Works**, 134 No. 22d St., Phila., Pa.

JOS. R. FOSTER & SONS.

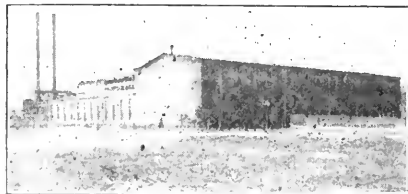

**Foster, J. R. & Sons**, Second and Clearfield Sts., Phila., Pa.

[Dyers of worsted, woolen and merino yarns, webbing, raw wool, slubbing, etc. Fast black on skein cotton. Single worsted dyeing a specialty. Dyers and finishers of dress goods, men's wear, cloakings, etc.]

**Harris, T. A. & Co.**, Continental Dye Works, 147 West Thompson St., Phila., Pa.

Haslam & Querner, Rainbow Dye Works, Lehigh Ave. and Howard St., Phila., Pa.

Higgins, D. A. & Co., 635 W. 130th St., New York, N. Y.

Hough, Mark, Enterprise Dye Works, Woonsocket, R. I.

**Hulton, James & Bros.**, Ruth and Tusculum Sts., Phila., Pa.

Kitchen, Jas. G. & Co., Chelton Ave., Germantown, Pa.

Knowlton, J. E., Putnam, Conn.

Kreusser & Buschers, 509-11 W. 45th St., New York.

Leary Dyeing and Cleaning Works, Rochester, N. Y.

Leithead, R. S. & Sons, Huntington and Collins Sts., Phila., Pa.

Littlewood, G. J. & Sons, Ltd., Albion Dye & Bleach Works, Main St., Manayunk, Pa.

**Lorimer's, W. H. Sons' Co.**, Ontario and Lawrence Sts., Phila., Pa.  
**Masland, C. H. & Sons**, Amber and Westmoreland Sts., Phila., Pa.  
**Masland, J. W. & Co.**, Clearfield and Jasper Sts., Phila., Pa.  
**Merchants Dyeing Co.**, Chicago, Ill.  
**Minto, James D.**, Manton, R. I.  
**Moore, Sam'l, & Sons**, 3211-23 Amber St., Phila., Pa.  
**Molt Bros.**, Millbury, Mass.  
**Nolan, John**, Keystone Dye Works, 1716 Howard St., Phila., Pa.  
**Orr Bros.**, Pawtucket, R. I.  
**Prospect Dye Works**, 1120-32 Moss St., Reading, Pa.  
**Schanz, Frank**, Lehigh Dye Works, 2719 Germantown Ave., Phila., Pa.  
**Spiering, Adolph**, Appleton, Wis.  
**Weinmann, Thos. & Sons**, 1732 Howard St., Phila., Pa.

R. WOLFENDEN & SONS.



**Wolfenden, R. & Sons**, Attleboro, Mass.

[Dyers and Bleachers of woolen and worsted yarns, hosiery, etc. See our name under headings: Slubbing and fast-color dyers, skein yarn dyers, woolen and cotton hosiery dyers and bleachers and pile fabric dyers.]

**Woolen and Worsted Knit Goods Dyeing.**

**Burton, Andrew, E.**, Penn St., and Belfield Ave., Phila., Pa.  
**Cohoes Dye Works, Duncan & Baillie**, Cohoes, N. Y.  
**Firth & Foster Co.**, Providence Dyeing & Finishing Works, Emerald and York Sts., Phila., Pa.

**Harris, T. A. & Co.**, Continental Dye Works, 147 West Thompson St., Phila., Pa.  
**Hough, Mark**, Enterprise Dye Works, Woonsocket, R. I.  
**Kagermann, Edward**, Charlotte Dye Works, 1210-20 Orrianna St., Phila., Pa.  
**Star Knitting Mills**, Norristown, Pa.  
**Wolfenden, R. & Sons**, Attleboro, Mass.

**Woolen and Worsted Knit Goods Bleaching.**

**Cohoes Dye Works, Duncan & Baillie**, Cohoes, N. Y.  
**Davidson & Brooke, Orianna Bleach Works**, 2560 No. 3d St., Phila., Pa.  
**Harris, T. A. & Co.**, Continental Dye Works, 147 West Thompson St., Phila., Pa.  
**Wolfenden, R. & Sons**, Attleboro, Mass.

**Woolen and Worsted Dress Goods Dyeing and Finishing.**

**Barretts, Palmer & Heal**, 346 Canal St., New York, N. Y.  
**Capucine Co.**, The, Lowell, Mass.  
**Firth & Foster Co.**, Providence Dyeing & Finishing Works, Emerald and York Sts., Phila., Pa.  
**Foster, J. H. & Sons**, Second and Clearfield Sts., Phila., Pa.  
**Geriach, A. & Co.**, College Point, N. Y.  
**Kingsboro Dye Works**, Gloversville, N. Y.  
**Lawrence Dye Works Co.**, The, Lawrence, Mass.  
**Mathwig, L. H.**, Lemars, Ia.  
**Molt Bros.**, Millbury, Mass.  
**Moore, I. E. & Co.**, Kensington Ave. and Huntingdon St., Phila., Pa.  
**Oxford Dye Works**, No. Oxford, Mass.  
**Providence Finishing Works**, Providence, R. I.  
**Valkone, The, Dye & Finishing Works**, Turner and Mascher Sts., Phila., Pa.  
**Wessel Dyeing & Proofing Co.**, 178-S3 Wooster St., New York.

# *Bleaching and Dyeing*

## FOR THE *Knit Goods Trade.*

We know what is wanted and can give it to you.  
 We do our work promptly and charge fair prices.

— GIVE US A TRIAL. —

**SAMUEL ROWLAND, Schuylkill Haven Bleach and Dye Works.**  
**SCHUYLKILL HAVEN, PA.**

**Windle, A. D. & W. W.**, West Millbury, Mass.  
World Dyeing & Finishing Works, 2742 Mascher St., Phila., Pa.

### Woolen and Worsted Men's Wear and Heavy Goods, Piece Dyeing and Finishing.

Brightwood Mfg. Co., The, No. Andover, Mass.  
**Firth & Foster Co.**, Providence Dyeing & Finishing Works, Emerald and York Sts., Phila., Pa.  
Fidelity Finishing Works, S. W. corner Mascher and Turner Sts., Phila., Pa. Finishing only.  
**Foster, J. R. & Sons**, Second and Clearfield Sts., Phila., Pa.  
Kennedy & Britt, Conshohocken Dyeing & Finishing Works, Hascher and Jefferson Sts., Phila., Pa.  
**Molt Bros.**, Millbury, Mass.  
Moore, I. E. & Co., Kensington Ave. and Huntingdon St., Phila., Pa.  
**Oxford Dye Works**, No. Oxford, Mass.  
Valkone Dye & Finishing Works, Turner and Mascher Sts., Phila., Pa.  
**Windle, A. D. & W. W.**, West Millbury, Mass.

### Woolen Cloth and Satinet Printing.

Capstick, John & Sons, Montville, N. J.  
Manhattan Print Works, Passaic, N. J.

### Cotton and Woolen Piece Goods Finishing.

American Warehouse Co., Spray, N. C.  
Beardwood, Thos. & Bro., 1640 N. 6th St., Phila., Pa.  
Campbell, John J., 3d and Cumberland Sts., Phila., Pa.  
Capstick, John & Sons, Montville, N. J.  
Coulter & Lowry, Phila., Pa., and Greensboro, N. C.  
**Firth & Foster Co.**, Providence Dyeing & Finishing Works, Emerald and York Sts., Phila., Pa.  
Gilmour, R. & A. J., 2631 No. 3d St., Phila., Pa.  
Haigh, J. C. & Co., Columbia Finishing Works, 1729 Gillingham St., Frankford, Pa.  
**Harris, T. A. & Co.**, Continental Dye Works, 147 West Thompson St., Phila., Pa.  
Harvey, D. & Son, Janney, below Allegheny Ave., Phila., Pa.  
Industrial Dyeing & Finishing Works, 323-45 Frankford Ave., Phila., Pa.  
Johnson & Bemis, Merchants Print Works, 416 West 14th St., New York.  
**New York Mills, The**, New York Mills, Oneida Co., N. Y.  
Peterson, Geo. W., Agt. Manayunk Wks., Main St., Manayunk, Phila., Pa.

### Cotton Stock Dyeing.

Bishop, Robert, Boston, Mass.  
Chester Dyeing Co., Ltd., Edgemont Ave., Chester, Pa.  
**Cohoes Dye Works, Duncan & Baillie**, Cohoes, N. Y.  
Eagle Dye Works, Pawtucket, R. I.  
Hookset Mfg. Co., Hookset, N. H.  
**Indian Orchard Co.**, Indian Orchard, Mass.  
**Lorimer's, W. H. Sons Co.**, Ontario and Lawrence Sts., Phila., Pa.  
Mackintosh, D. & Sons Co., Holyoke, Mass.  
Merchants' Dye Works, Dedham, Mass.  
**New York Mills, The**, New York Mills, Oneida Co., N. Y.  
Roxboro Mills Co., Freeland Ave. and Walnut Lane, Phila., Pa.  
Slatersville Finishing Co., Slatersville, R. I.  
Waterford Dye Works, 73 Third St., Waterford, N. Y.  
**Whittier Mills**, Springfield, Mass.

### Cotton Yarn Dyeing.

Adroit Dye Works, Ditman St., Frankford, Phila., Pa.  
American Chemical & Textile Coloring Co., Wilmington, N. C.  
**Brophy's, T. Sons**, Jasper above Clearfield Sts., Phila., Pa.

## John H. Lorimer,

Sole agent for the sale of

### The Lorimer Machinery Company's Specialties,

and other mechanical contrivances for

#### Scouring

Yarns, Wool, etc., etc.

#### Washing

Hair, Cotton Waste, etc.

#### Degumming

Ramie and kindred Fibres.

#### Treating

Flax Straw and Tow.

#### Dyeing

Yarns, Slubbing, etc., etc.

#### Dyeing

Cotton, Wool and Raw Stock of all sorts.

#### Drying

all of the above in whatever form required.

OFFICE:

**Ontario and Lawrence Streets, Philadelphia, Pa., U. S. A.**

Cable address, "Lorimer, Philadelphia."

Brown, H. H. & Sons, Paterson, N. J.  
 Bower, W. H., 912 Fairmount Ave., Phila., Pa.  
 Brehm & Stehle, Allegheny Dye Works, Trenton and Allegheny Ave., Phila., Pa.  
 Buckhalter, Fred, Front and Clearfield Sts., Phila., Pa.  
 Burns, Wm. H., Frankford, Phila., Pa. Successor to Bromley & Burns.  
**Burton, Andrew**, Penn St. and Belfield Ave., Phila., Pa.

Carson, John W., 2d above Rising Sun Ave., Phila., Pa.  
 Clough, Jos., Sons & Co., 618 No. 24th St., Phila., Pa.  
 Cotter & O'Keefe, Adams and Ruan Sts., Frankford, Pa.

**Firth & Foster Co.**, Providence Dyeing & Finishing Works, Emerald and York Sts., Phila., Pa.

**Forrest, John, American Yarn Print Works**, 134 No. 22d St., Phila., Pa.

**Foster, J. R. & Sons**, Second and Clearfield Sts., Phila., Pa.

Foster, E. & Son, Cumberland, Md.

Globe Dye Works, Little Falls, N. J.

**Greene & Daniels Mfg. Co.**, Pawtucket, R. I.

Green, J. C., Southgate St., Worcester, Mass.

Greenwood, John, Emerald and Hunington Sts., Phila., Pa.

**Greenwood, R. & Bault, Globe Dye & Bleach Works**, Oxford and Worth Sts., Frankford, Pa.

**Harris, T. A. & Co.**, Continental Dye Works, 147 W. Thompson St., Phila., Pa.

Harrison Yarn & Dyeing Co., Pawtucket, R. I.

**Holmes, John C. Co.**, Springfield, Vt.  
**Home Bleach & Dye Works**, Pawtucket, R. I.

Hughes Mfg. Co., The, Trenton Ave. and Clearfield St., Phila., Pa.

**Hulton, James & Bros.**, Ruth and Tusculum Sts., Phila., Pa.

**Indian Orchard Co.**, Indian Orchard, Mass.

Ingram, David; Est. of, Long Island City, N. Y.

Ingram, David; Estate of, L. I. City Dye Works, Astoria, N. Y.

Kedward, William, Cedar and Somerset Sts., Phila., Pa.

Liberty Dye Works, Elias Schulze & Son, Reading, Pa.

**Lorimer's, W. H. Sons Co.**, Ontario and Lawrence Sts., Phila., Pa.

L. B. LUTTHLEN.

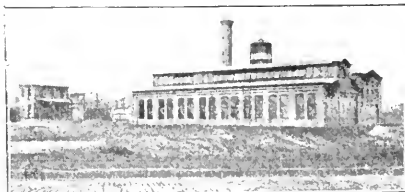

Luthlen, L. B., J and EStaugh Sts., Phila., Pa.

[Cotton yarns dyed in every known shade. The above cut represents the fine new dyehouse recently erected in Kensington, at J and EStaugh Sts. Prompt attention paid to inquiries.]

Maryland Bleach & Dye Works, Baltimore.

Mason, Robt. D. Co., The, Pawtucket, R. I.

Mathes Bros., 110 Turner St., Phila., Pa.

McDougal, John W., 419 West 24th St., New York, N. Y.

Meinhardt's, C. J. Sons, Emerald, above Westmoreland St., Phila., Pa.

**Molt Bros.**, Millbury, Mass.

Morganstein, M., Suffolk, Va.

New England Warp Co., New Haven, Conn.

**New York Mills, The**, New York Mills, Oneida Co., N. Y.

Orr, James, Attleboro, Mass.

**Pawtucket Dyeing & Bleaching Co.**, Pawtucket, R. I.

Philadelphia Dye Works, Hancock, below Berks Sts., Phila., Pa.

**Pond Lily Co., The**, New Haven, Conn.

Prospect Dye Works, 1120-32 Moss St., Reading, Pa.

**Pawtucket Dyeing & Bleaching Co.,**

BLEACHERS AND  
DYERS OF

**COTTON YARNS AND STOCKINET.**

OFFICE WITH **BLODGETT & ORSWELL CO.**, Manufacturers of Glazed Yarns,  
232 FRONT ST., PAWTUCKET, R. I.

WORKS: Hancock, Mascher and Thompson Sts.,  
OFFICE: 147 W. Thompson St., PHILADELPHIA.

**T. A. HARRIS & CO.**

**Continental Dye Works**

ALL COLORS  
DYED on Wool and Cotton  
Yarns, Hosiery, etc. Jersey Cloth, Elderdown, Athletic  
Sweater and Cardigan Yarns. Fast Black on Cotton Hose a Specialty.  
Address all communications to works.

Sarfert, Max, Germania Dye Works, Kensington and Allegheny Aves., Phila., Pa.  
 Schweigart, J., American Dye Works, Trenton Ave. and Lippincott St., Phila., Pa.  
 Smith, Thos., Orthodox and Race Sts., Frankford, Pa.  
 Taunton Dye Works & Bleachery Co., Taunton, Mass.  
 Tarboro Dye Works, Tarboro, N. C.  
 Utica Dyeing Co., 3rd Ave. and Broad St., Utica, N. Y.  
 Walker Bros., Chelsea, Mass.  
 Warren W. Thread Works, Westfield, Mass.  
 Waxler, Jno. L., Frankford St. and Frankford Creek, Frankford, Pa.  
 White, A. W., 1410 Oxford St., Phila., Pa.  
**Whittier Mills**, Springfield, Mass.  
**Wood Dyeing Co., The Peter**, Worcester, Mass.  
 Worcester Bleach & Dye Works Co., Worcester, Mass.

Ingram, Wm. A., Linen Yarn Bleachery, Cheltenham, Pa.  
 Kedward, William, Cedar and Somerset Sts., Phila., Pa.

THE WILLIAM H. LORIMER'S SONS  
 CO.

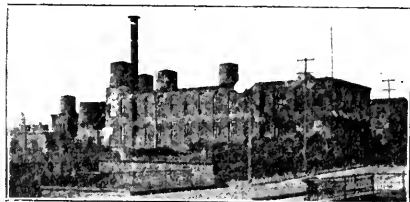

**Lorimer's, W. H. Sons Co.**, Ontario and Lawrence Sts., Phila., Pa.

[Manufacturers of Mercerized Yarns, and Dyers of all kinds and grades of Yarn. William H. Lorimer's Sons Co., Ontario and Lawrence Streets, Philadelphia, Pa.; New York office, Room 911, New York Life Building, 346 Broadway.]

### Cotton Yarn Bleaching.

Allen Dyeing Co., The, 2848 Frankford Ave., Phila., Pa.  
 Barnesville Mfg. Co., Barnesville, Ga.  
**Brophy's, T. & Sons**, Jasper, above Clearfield St., Phila., Pa.  
**Burton, Andrew**, E. Penn St., and Belfield Ave., Phila., Pa.  
 Clayville Co., Rockland, R. I.  
**Davidson & Brooks, Orianna Bleach Works**, 2560 No. 3rd St., Phila., Pa.  
 Fitch, Sam'l, Mfg. Co., Providence, R. I.  
**Greene & Daniels Mfg. Co.**, Pawtucket, R. I.  
**Greenwood, R. & Bault, Globe Dye & Bleach Works**, Oxford and Worth Sts., Frankford, Pa.  
**Harris, T. A. & Co.**, Continental Dye Works, 147 West Thompson St., Phila., Pa.  
**Holmes, John C. Co.**, Springfield, Vt.  
**Home Bleach & Dye Works**, Pawtucket, R. I.  
**Indian Orchard Co.**, Indian Orchard, Mass.

McCloskey, James, Margaret & Bermuda Sts., Phila., Pa.

New England Thread Co., Pawtucket, R. I.

**New York Mills, The**, New York Mills, Oneida Co., N. Y.

**Pawtucket Dyeing & Bleaching Co.**, Pawtucket, R. I.

**Pond Lily Co., The**, New Haven, Conn. Bleach Works, Walpole, Mass.

Quinlan, John & Co., Milford, N. H.

Warren, W., Thread Works, Westfield, Mass.

**Whittier Mills**, Springfield, Mass.

**Wood Dyeing Co., The Peter**, Worcester, Mass.

Worcester Bleach & Dye Works Co., Worcester, Mass.

### Cotton Yarn Mercerizing.

Gray, S. & Co., The, Walpole Dye and Bleach Works, Walpole, Mass.

**EDWARD KAGERMANN**,  
 1210-1220 Orrianna St., PHILADELPHIA.

**Charlotte Dye Works**, Cotton, Woolen,  
 Worsted, Hosiery.  
**FAST BLACK A SPECIALTY.**

**ANDREW BURTON**,

**PENN DYE WORKS**, COTTON, WOOLEN AND FANCY DYER.

A Specialty of

**Fast Black and Fancy Colors in Hosiery.**

Penn St. and Belfield Ave., - Germantown, Phila., Pa.



**Greenwood, R. & Bault, Globe Dye & Bleach Works,** Oxford and Worth Sts., Frankford, Pa.  
**Harris, T. A. & Co.,** Continental Dye Works, 147 West Thompson St., Phila., Pa.  
**Home Bleach & Dye Works,** Pawtucket, R. I.  
**Indian Orchard Co.,** Indian Orchard, Mass.  
**Lorimer's, W. H. Sons Co.,** Ontario and Lawrence Sts., Phila., Pa.  
**Montgomery Co., The J. R.,** Windsor Locks, Conn.  
**New York Mills, The,** New York Mills, Oneida Co., N. Y.  
**Pennypack Yarn Finishing Co.,** Holmesburg Junction, Pa.  
 Schindel, S., Hagerstown, Md.

**Cotton Hosiery Dyeing and Finishing.**

Angola Dyeing Co., Hancock and Huntingdon Sts., Phila., Pa.  
 Brandywine Dye Works, Wilmington, Del., blacks and tans.  
 Chester, E. G. Dyeing Co., Trenton and Susquehanna Aves., Phila., Pa.  
**Cohoes Dye Works, Duncan & Baillie,** Cohoes, N. Y.  
 Consolidated Hosiery & Finishing Co., Hancock and Somerset Sts., Phila., Pa.  
 Dick, Christian, Riverside, N. J.  
 Durham Dyeing Co., Durham, N. C.  
 Elizabeth City Knitting Mills, Elizabeth City, N. C.  
 Fleming, Chas. H., Silver Star Dye Wks., Allegheny Ave., Phila., Pa.  
 Gold Crown Hosiery Mills, Charlotte, N. C.  
**Harris, T. A. & Co.,** Continental Dye Works, 147 West Thompson St., Phila., Pa.

**JAMES HULTON & BROTHERS.**

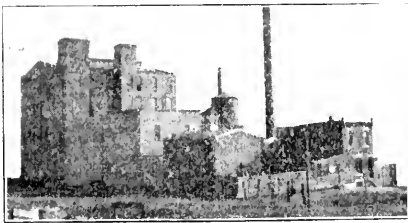

**Hulton, James & Bros.,** Ruth and Tusculum Sts., Phila., Pa.  
 [Dyers of cotton, woolen, and worsted yarns, and slubbing, in fast alizarine colors. Special attention given to fancy colors on hosiery. Write for quotations before placing orders.]

**Kagermann, Edward,** Charlotte Dye Works, 1210-20 Orrianna St., Phila., Pa.  
 Keystone Fast Black Dye Works, 1838-40 E. Huntingdon St., Phila., Pa.  
 Knause, H., Knause Bleachery, Hamburg, Pa.  
 Knoll & Althouse, Neversink Dye Works, 925-929 Muhlenberg St., Reading, Pa.  
 Lowell Hosiery Co., Lowell, Mass.  
 McCauley, T., Collanade Dye Works, 2109 E. Somerset St., Phila., Pa.  
**Pond Lily Co., The,** New Haven, Conn.  
**Rowland, Samuel,** Schuylkill Haven, Pa.  
 Standard Fast Black Dye Works, 3211 Frankford Ave., Phila., Pa.  
 Waters, D. F., 53 and 55 Winter St., Germantown, Pa.  
 Weber & Co., 1725 No. Howard St., Phila., Pa.  
 Wiconisco Dyeing Co., Wiconisco, Pa.  
**Wolfenden, R. & Sons,** Attleboro, Mass.

**Cotton Hosiery Bleaching and Finishing.**

Barrett, Wm., Pilling St., Frankford, Phila., Pa.  
**Davidson & Brooke, Orianna Bleach Works,** 2560 No. 3d St., Phila., Pa.  
 Hamburg Bleach Works, Hamburg, Pa.  
**Harris, T. A. & Co.,** Continental Dye Keystone Bleachery, Hamburg, Pa.  
 Knause, H., Knause Bleachery, Hamburg, Pa.  
 Lehigh Steam Bleachery, 320-322-324 New St., So. Bethlehem, Pa.  
 Lowell Hosiery Co., Lowell, Mass.  
 McCloskey, James, Margaret and Bermuda Sts., Phila., Pa.  
 Philadelphia Hosiery Finishing Works, 3211 Frankford Ave., Phila., Pa.  
**Rowland, Samuel,** Schuylkill Haven, Pa.  
 Royer's Ford Dye Works, Royer's Ford, Pa.  
**Wolfenden, R. & Sons,** Attleboro, Mass.

**Slubbing and Worsted Yarn Dyeing in Fast Black and Colors for Weaving Trade.**

**Brophy's, T. & Sons,** Jasper, above Clearfield St., Phila., Pa.  
**Burton, Andrew,** Penn St. and Belfield Ave., Phila., Pa.  
**Cranston Worsted Mills,** Bristol, R. I.

**DAVIDSON & BROOKE, ORIANNA BLEACH WORKS.**  
**BLEACHERS**

Of Turkish Towels, Cotton Yarns, Underwear, Tapes and Hosiery.  
 Turkish Towels made up to suit the trade and shipped to any point.  
 2560 No. 3rd St., PHILADELPHIA.  
 Correspondence solicited.

**Firth & Foster Co.**, Providence Dyeing & Finishing Works, Emerald and York Sts., Phila., Pa.

**Foster, J. R. & Sons**, Second & Clearfield Sts., Phila., Pa.

**Hulton, James & Bros.**, Ruth and Tusculum Sts., Phila., Pa.

Hussong, Joseph, Camden, N. J.

**Lorimer's, W. H. Sons & Co.**, Ontario and Lawrence Sts., Phila., Pa.

**Molt Bros.**, Millbury, Mass.

**Wolfenden, R. & Sons**, Attleboro, Mass.

Hussong, Joseph, Camden, N. J.

### Cotton Hosiery Printing. (Resist and Extract).

Bechtold, Albert, Mascher, above Oxford Sts., Phila., Pa.

Franklinville Dye Works Co., Ltd., Lawrence, Luzerne & 5th Sts., Phila., Pa.

Heinemann, Harry J. & Co., 2042-46 Palethorp St., Phila., Pa.

**Kagermann, Edward**, Charlotte Dye Works, 1210-20 Orrianna St., Phila., Pa.

Knoll & Althouse, Neversink Dye Works, 925-29 Muhlenberg St., Reading, Pa.

Liberty Dye Works, Elias Schulze & Son, Reading, Pa.

Payton, Albert J., 163-167 West Oxford St., Phila., Pa.

Prospect Dye Works, 1120-32 Moss St., Reading, Pa.

Saxon Dye Works, Richmond and Kettlewell Sts., Phila., Pa.

Sutro, E. & Son, Indelible Dye Works, 3110 Edgemont St., Phila., Pa.

Urner, W. C. & Co., Spring City Hosiery Mills, Spring City, Pa.

### Cotton Piece Goods, Bleaching and Finishing.

Acme Bleaching Co., 1210-12 Turner St., Allentown, Pa.

**Aspinook Co.**, Jewett City, Conn.

Aurora Bleachery & Dye Works, Aurora, Ill.

Baneroft, Joseph & Sons Co., Wilmington, Del.

Bronx Co., 17th St. and Bronx River, New York, N. Y.

Brookdale Bleachery, Hohokus, Bergen Co., N. J. [Clay filled work a specialty.]

Clear Water Bleaching Mfg. Co., Augusta, Ga.

Cold Spring Bleaching & Finishing Wks., Yardley, Pa.

**Cohoos Dye Works, Duncan & Bailie**, Cohoos, N. Y.

Coulter & Lowry Co., Phila., Pa., and Greensboro, N. C.

Danvers Bleachery & Dye Works, Peabody, Mass.

Dempsey Bleachery & Dye Works, Pawtucket, R. I.

Fall River Bleachery Co., Fall River, Mass.

Farwell Bleachery, Lawrence, Mass.

Frankford Linen Finishing Co., Frankford Ave. and Eacony St., Frankford, Pa.; linens.

Franklin Bleaching & Finishing Wks., Ltd., 70th St. near Haverford Road, Phila.; also linens.

Gabriel's, Henry Sons, Allentown, Pa.

Glenwood Works, Medford, Mass. Boston office, 31 Bedford St.

Great Falls Bleachery and Dye Works, Somersworth, N. H.

Greenwich Bleachery, The, East Greenwich, R. I.

Hamden Bleachery, Chicopee Falls, Mass.

Indianapolis Bleaching Co., Indianapolis, Ind.

Kerr Bag Mfg. Co., Concord, N. C.

Lanett Bleachery & Dye Works, West Point, Ga. Wellington, Sears & Co., Boston, s. agts.

Lewiston Bleachery & Dyeworks, Lewiston, Me.

Liondale Bleach, Dye & Print Works, Rockaway, N. J.

Lowell Bleachery, Lowell, Mass.

Millbank Bleach & Dye Works, Pompton Lakes, N. J.

Millville Mfg. Co., Millville, N. J.

**New York Mills, The**, New York Mills, N. Y.

Newburg Bleachery, Joseph Chadwick & Sons, Newburg, N. Y.

Pontiac Bleachery, Pontiac Mfg. Co., Pontiac, R. I.

Providence Dyeing, Bleaching & Calendering Co., Providence, R. I.

**Providence Mills Mfg. Co.**, 55th St. and Girard Ave., Phila., Pa.

Rockland Bleach & Dye Works, Brooklandville, Md.

Sayles, F. A., prop. Sayles Bleacheries, Saylesville, R. I.

Standard Bleachery Co., Carlton Hill, N. J.

Sykes, D., 2080 East Dauphin St., Phila., Pa.

**United States Finishing Co.**, 320 Broadway, New York, N. Y.

Utica Willowvale Bleaching Co., Chadwick's, N. Y.

**Walcott & Campbell Spinning Co.**, New York Mills, Oneida Co., N. Y.

Waltham Bleachery & Dye Works, Waltham, Mass.

**Whittier Mills**, Springfield, Mass.

### Cotton Piece Dyeing and Finishing.

Acme Bleaching Co., 1210-12 Turner St., Allentown, Pa.

Anawamscott Mills, Drownville, R. I.  
Aspinook Co., Jewett City, Conn.

- Bancroft, Joseph, & Sons Co., Wilmington, Del.
- Barretts, Palmer & Heal, Nordhoff, N. J.
- Boston Finishing Works, Williamstown, Mass.
- Bronx Co., 177th St. and Bronx River, New York, N. Y.
- Brookdale Bleachery, Hohokus, N. J., [Clay filled work a specialty.]
- Capstick, John & Son, Montville, N. J.
- Cohoes Dye Works, Duncan & Baile,** Cohoes, N. Y.
- Cranston Print Works Co., Cranston, R. I.
- Donahue Dyeing Co., Paterson, N. J.
- Glenlyon Dye Works, Saylesville, R. I.
- Glenwood Works, Medford, Mass. Boston office 31 Bedford St.
- Horrocks & Bro., Adams and Unity Sts., Frankford, Pa.
- Howard & Co., Rahway, N. J.
- Lafferty, John, & Bro., Gunner's Run Dye & Finishing Wks., Frankford Ave. and Westmoreland St., Phila., Pa.
- Liondale Bleach, Dye & Print Works, Rockaway, N. J.
- Narwood Bros., 942 Lafayette Ave., Brooklyn, N. Y.
- New York Mills, The,** New York Mills, Oneida Co., N. Y.
- Ohio Falls Dye & Finishing Works,** Louisville, Ky.
- Oxford Dye Works,** No. Oxford, Mass.
- Pond Lily Co., The,** New Haven, Conn.
- Quaker City Dye Works Co., 110 Oxford St., Phila., Pa.
- Queen Dyeing Co., Providence, R. I.
- Reliance Textile & Dye Works, Covington, Ky.
- Sterling Dyeing & Finishing Co., Sterling, Conn.
- Stuermann, Abram, Jersey City, N. J.
- Summerdale Dyeing, Printing and Finishing Works, Holmesburg, Pa.
- Swansea Dye Works, Fall River, Mass.
- United States Finishing Co.,** 320 Broadway, New York, N. Y.
- Walcott & Campbell Spinning Co.,** New York Mills, Oneida County, N. Y.
- Waldrich Bleachery, Delawanna, N. J.
- Waltham Bleachery & Dye Works, Waltham, Mass.
- Whittier Mills,** Springfield, Mass.
- Whittle Eye Works, Bellefont, R. I.

### Cotton Cloth, Printing and Finishing.

- Adams Print Works, Malden, Mass.
- American Printing Co., Fall River, Mass.
- Arnold Print Works, North Adams.
- Aspinook Co., Jewett City, Conn.
- Bronx Co., 177th St. and Bronx River, New York, N. Y.
- Cochecho Mfg. Co., Dover, N. H.
- Clyde Bleachery & Print Works, River Point, R. I.
- Cochrane Mfg. Co., Malden, Mass. N. Y. office, Worth St.
- Cranston Print Works Co., Cranston, R. I.
- Crystal Spring Dyeing & Bleaching Co., Fall River, Mass.
- Dunnell Branch, U. S. Finishing Co.,** N. Y., Pawtucket, R. I.
- Dutchess Company, Wappinger's Falls, N. Y.
- Edgewater Print Works, Frankford Ave. and Mill St., Frankford, Pa.
- Eureka Printing Co., Athenia, N. J.
- Gloucester City Mfg. Co., Gloucester City, N. J.
- Liondale Bleach, Dye & Print Works, Rockaway, N. J.
- Manchester Mills, Manchester, N. H.
- Mansfield Print Works, Mansfield, Mass.
- Middlesex Beach, Dye & Print Works, Somerville, Mass.

Established 1847.

Incorporated 1890.

# John Hope & Sons Engraving and Manufacturing Co.,

PROVIDENCE, R. I., U. S. A.,

Engravers and Builders of

## ENGRAVING MACHINERY

For General Fabric Printers.

Patentees of Pantograph Engraving Machines, used by all the Print Works throughout the United States. This machine has been remodeled and includes all the latest improvements to facilitate and simplify the Engraving of Copper Rolls; also Builders of **RULING MACHINES** for Steel and Copper Plate Engraving. We guarantee these machines as being perfectly accurate and first-class in every respect.

 Catalogues sent on application.

Mystic Print & Dye Works, Medford, Mass.  
 Nashua Mfg. Co., Nashua, N. H.  
 Nuttall, I., 126-128 Fountain St., Phila., Pa.  
 Passaic Print Works, Passaic, N. J.  
 Pendlebury, S. & Son, Aramingo Dyeing, Finishing & Printing Wks., Buckius Lane, Frankford, Pa.  
 Reliable Textile & Dye Wrks, Covington, Ky.  
 Rockport Print Works, Garnerville, N. Y.  
 Silver Spring Bleaching & Dyeing Co., 387 Charles St., Prov., R. I.  
 Southbridge Printing Co., Southbridge, Mass.  
**Sterling Dyeing & Finishing Co., U. S. Finishing Co.**, Sterling, Conn.  
 Stifel, J. L. & Sons, Wheeling, Va.  
 Summerdale Dyeing, Printing and Finishing Works, Holmesburg, Phila., Pa.  
 Wilson's, Chas. Sons, Meadow Spring Dye & Print Wks., 1633 Meadow St., Frankford, Pa.

---

### Yarn Printing.

Chenango Dyeing Co., silk, Norwich, N. Y.  
 Fileppi, Domenico, silk, Paterson, N. J.  
**Forrest, John, American Yarn Print Wks.**, 134 No. 22d St., Phila., Pa.

---

### Silk Yarn Dyeing.

Anger & Simon Silk Dyeing Co., Paterson, N. J.  
 Blum, Nicholas, 165th St., near Brook Ave., New York, N. Y.  
 Bolton Bros. Silk Dyeing Co., Paterson, N. J.  
 Brooklyn Silk Dye Works, 401 Manhattan Ave., Brooklyn, N. Y.  
 Clarke, Thos., Paterson, N. J.  
 College Point Silk Dyeing Co., College Point, N. Y.  
 Donnelly, A. J. & Co., 1230, 32 and 34 Orianna St., Phila., Pa.  
 Dordoni Silk Dyeing Co., Paterson, N. J.  
 Formanus, Stumpf & Sharpe, Paterson, N. J.  
**Forrest, John, American Yarn Print Works**, 134 No. 22d St., Phila., Pa.  
 Garde, Robt., Paterson, N. J.  
 Gautschy Silk Dyeing Co., he, Paterson, N. J.  
 Geering, Emil, Paterson, N. J.  
 Hellwig, Albert & Co., 9th & Buttonwood Sts., Phila., Pa.

Hoboken Silk Dye Works, Hoboken, N. J.  
 Hoof & Matter Silk Dyeing Co., 335 West 4th St., New York, N. Y.  
 Iliffe, John, 1112 No. Front St., Phila., Pa.  
 Kearns Bros., Paterson, N. J.  
 Knipscher & Maass Silk Dyeing Co., Paterson, N. J.  
 Lotte & Mazerres Co., The, Allentown, Pa.  
 Maupai, F. P., 585 Hudson St., New York, N. Y.  
 Meier, Frank, 220 Division St., West Hoboken, N. J.  
 Morel, Emil, Webster Ave., Jersey City, N. J.  
 Neale & Good, Paterson, N. J.  
 Peerless Silk Dye Works, Willard & Jasper Sts., Phila., Pa.  
 Riley, Edward, Paterson, N. J.  
 Ross, Wm., Summer Ave., Allentown, Pa.  
 Sheehan, D. J., Paterson, N. J.  
 Stumpf & Schwartz, 530 West 4th St., New York, N. Y.  
 Teschemscher, Wm., 250 Mertle Ave., Brooklyn, N. Y.  
 Thurkauf, Virgil, 435 West 53d St., New York, N. Y.  
 Versen, Albert F., 232 East 43d St., New York, N. Y.  
 Weigle, C. H., 140 East 49th St., New York, N. Y.  
 Wehrlin & Brugger, College Point, N. Y.  
 Weidman Silk Dyeing Co., Paterson, N. J.

---

### Silk Piece Printing and Finishing.

American Silk Dyeing & Finishing Co.,  
 Cameron & Krug, Paterson, N. J.  
 Chegnay Henri Co., Bank and Hudson Sts., New York, N. Y.  
 Cramer & King Printing Co., Paterson, N. J.  
 Glenlyon Dye Works, Phillipsdale Branch, Providence, R. I.  
 McCowen, John, 413-15 W. Broadway, New York.  
 Novelty Silk Printing Co., Paterson, N. J.  
 Oriental Silk Printing Co., Paterson, N. J.  
 Peerless Finishing Co., Nyack, N. Y.

---

### Silk Piece Goods Dyeing and Finishing.

Alexander Dye Works, Lodi, N. J.

---

# American Yarn Printing Works.

**JOHN FORREST,**

**Printer of Cotton, Woolen, Silk and Worsted Yarns and Warps for Woven and Knit Goods. Bleaching for Cotton and Woolen Yarns a Specialty.**

134 to 150 North 22d St., PHILADELPHIA, PA.

Barrett, Nephews & Co., 334 Canal St.,  
New York, N. Y.

Boettger Piece Dye Works, Lodi, N. J.

Central Silk Finishing Co., Paterson, N.  
J.

Charavay & Bodvin, 174 Worth St., New  
York, N. Y.

Crew's Silk Finishing & Piece Dye Works,  
Paterson, N. J.

Davis & Quirk, 307 St. Marks Ave., Brook-  
lyn, N. Y.

Donahue Dyeing Co., Paterson, N. J.

Henshall, Thos., Paterson, N. J.

Industrial Dyeing & Finishing Works,  
3829-45 Frankford Ave., Phila., Pa.

Lodi Dry Dyeing Co., Passaic, N. J.

P. & P. Dyeing Co., Paterson, N. J.

Paterson Silk & Dyeing Assn., Paterson,  
N. J.

Peerless Finishing Co., Nyack, N. Y.

Shutt, George, Little Falls, N. J.

Stead, Miller & Co., American, above  
Huntington St., Phila., Pa.

### Silk Piece Watering and Embossing.

American Novelty Printing & Embossing  
Works, New York, N. Y.

Bader, E., 519 W. 45th St., New York, N.  
Y.

Boettger & Heinze, 500 Broome St., New  
York, N. Y.

Mayer, W. H., 104 Walker St., New York,  
N. Y.

New York Watering Co., 72 Wooster St.,  
New York, N. Y.

Smith & Choffin, 525 West 24th St., New  
York, N. Y.

### Pile Fabric Dyers.

Donahue Dyeing Co., Hamburg Ave.,  
Paterson, N. J.

Hart Textile Co., Woonsocket, R. I.

New York Mills, The, New York Mills,  
Oneida Co., N. Y.

Waterhead Mills, Lowell, Mass.

Wolfenden, R. & Sons, Attleboro, Mass.

### Pile Fabric Finishers.

Crompton Co., Crompton, R. I.

Donahue Dyeing Co., Hamburg, Paterson,  
N. J.

Manhattan Print Works, Passaic, N. J.

New York Mills, The, New York Mills,  
Oneida Co., N. Y.

Timme, E. F. & Son, Paterson, N. J.

Walker, Robt. J., Star Finishing Works,  
22-30 West Girard Ave., Phila., Pa.

## SHODDY AND EXTRACT MANUFACTURERS.

Acme Woolen Mill Co., Cleveland, O.

Agan, F. W., Ludlow, Vt.

Allen, Wm. & Son, Howard St. below  
Lehigh Ave., Phila., Pa.

Ashton, Jas., 2621 Collins St., Phila., Pa.

Barnet, Wm., Westerlo and Church Sts.,  
Albany, N. Y.

Basch & Greenfield Co., Summer Ave.,  
Newark, N. J.

Beaumont Bros., East Foxboro, Mass.

Becker, Chas. W., Amsterdam, N. Y.

Blakely, Jno. & Son, 1085 Germantown  
Ave., Phila., Pa.

Blanding, C. L., Mfg. Co., Providence,  
R. I.

Bonitz, Herman, Co., Lodi, N. J. Sell di-  
rect.

Bradbury, John H., Lyme, Conn.

Broadbent, J. & Son, Unionville, Conn.

Burdick, Albert, Niantic, R. I.

Buttonwood Shoddy Mill, Wilkinsonville,  
Mass.

Campbell, James, Greystone Mills, Cen-  
tredale, R. I.

Charles River Woolen Co., Franklin,  
Mass.

Claremont Woolen Co., Claremont, N. H.

Coates, Mrs. Wm., Frankford Ave. and  
Mill St., Phila., Pa.

Collings Taylor Co., The, Cleveland  
Woolen Mills, Cleveland, O.

Coverdill, E. R., Clifton Heights, Pa.

Crane, B. F., West Millbury, Mass. Sell  
direct.

Crawford & Carney, Bennington, Vt.

Davis, Henry A. & Sons, 143 Summer St.,  
Providence, R. I.

Devlin, Chas., Linton and Kensington  
Aves., Phila., Pa.

Electric Woolen Mill, Worcester, Mass.  
Sell direct.

Extract Wool & Merino Co., The, Chat-  
tanooga, Tenn.

Farnum, Moses T., Wrentham, Mass.  
Sell direct.

Frankford Waste Co., Orchard and Van-  
dyke Sts., Frankford, Pa.

French, Hugh & Son, 3d and Cumber-  
land Sts., Phila., Pa.

Gardiner Shoddy Mills, Gardiner, Me.

Garfield Woolen Co., Garfield, N. J.

Garnett Bros., Clifton Heights, Pa.

= = *THE* = =

# CLEVELAND WOOLEN MILLS.

CLEVELAND, OHIO.

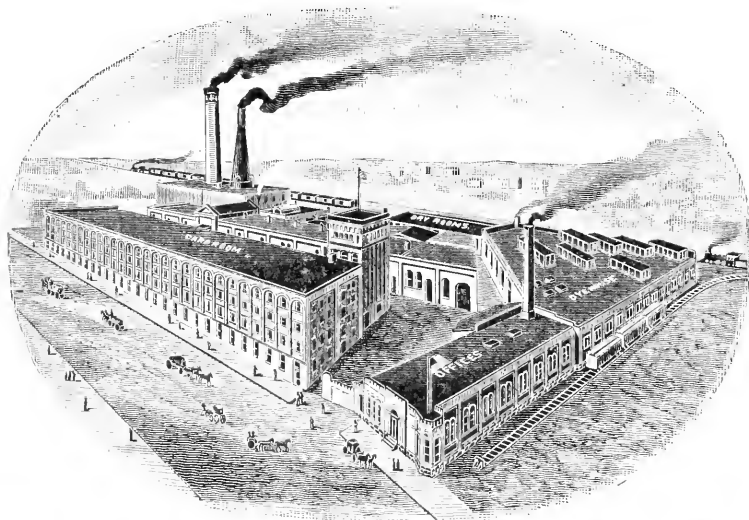

## THE COLLINGS, TAYLOR CO.,

MAKERS OF

**All Wool Shoddies.**

FINE LIGHT & COLORED STOCKS A SPECIALTY.

BRANCH OFFICES:

538 East Monroe Street, Little Falls, N. Y.

324 Colman Street, Ashmont, Mass.

38 N. Front Street, Philadelphia, Pa.



Glenside Woolen Mills, Skaneateles Falls, N. Y.

Gordon Bros., Hazardville, Conn.

Gould, O. L., Bangor, Me.

Gould Mfg. Co., Shrlrley, Mass. Sell direct.

Gray, T. H. & Co., Hyde Park, Mass.

Graves, Frank B., Broadway and Cherry Sts., Albany, N. Y.

Grosvenor Woolen Co., Palmer, Mass.

Hall, W. & Co., Lansdown, Pa.

Hapgood, E. & Son, Lowell, Mass.

Helper, John, Quinapoxet, Mass. Sell direct.

Hey, Benj. & Co., 124-128 Broadway, Cincinnati, O.

Hilton, Jas., Auburn, Mass. Sell direct.

Hudson Fibre Co., Hudson, N. Y.

Ikels, Wm. A., Holden, Mass. Sell direct.

Johnston Bros., Leverington Av. and Wilde St., Manayunk, Pa.

Kelly, Francis, 1728 Hancock St., Phila., Pa.

Kitchenman, John, York and Hope Sts., Phila., Pa.

Lawrence Felting Mills, Millville, Mass. Sell direct.

Lee, Wm. M., Westminster Depot, Mass. Little Falls Wool Extract Co., Little Falls, N. Y.

Lowenthal, W. & Co., Cohoes, N. Y.

Markland & Roessler, Swedeland, Pa.

McGann, O. W., Rutland, Mass.

M. B. SCHWAB, Pres.  
H. RAWITSER, Treas.

ED. GLUECK,  
Sec. and Gen. Mgr.

## Riverdale Woolen Co.,

MANUFACTURERS OF

# SHODDIES

OF EVERY DESCRIPTION.

Capacity 7,000,000 pounds per annum.

Custom Carbonizing and Garnetting a Specialty.

RIVERDALE, NORTHBRIDGE, - MASS.

New York Office: 140 Duane Street.

## C. S. DODGE, Lowell, Mass.

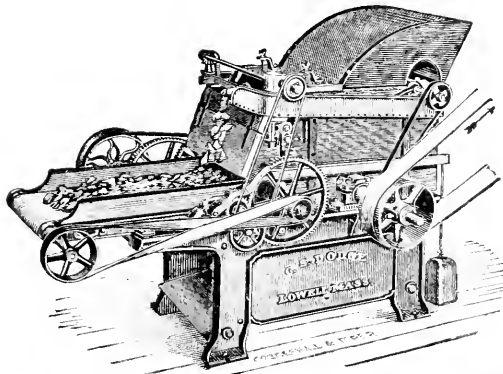

*Manufactnrer of the Latest Improved*

**Rag or Shoddy Picker**

and of the

**Improved Wool Bagging Machine.**

**Hot Forged Picker Pins,**

Write for Circular.

If you want your work done and done right, try us.

Enemies of Dirt. From the greasiest card strippings, to the finest Australian wool, we clean.

Dusting, Burring, Carding, Carbonizing, Scouring, Dyeing (Raw and Piece) for the Trade.

Scouring Capacity 10,000 lbs. per day. 22nd year. Dealers in Wool and Waste, etc.

**A. D. & W. W. Windle, West Millbury, Mass.**

Established 1876.

**COHOES SHODDY MILLS**

W. LOWENTHAL &amp; CO.

MANUFACTURERS OF

Wool, Merino and Cotton Shoddies and Cotton Bats,

AND DEALERS IN

*Rags, Wool Waste and Flocks.**Picking and Garnetting Custom Work a Specialty.*

BUY FOR SPOT CASH all kinds of Waste from Cotton, Woolen and Hosiery Mills. Please send us samples.

COHOES, N. Y., Remsen St.

BOSTON, MASS., 18 &amp; 20 W. 1st St.

**SHODDY** WM. H. H. SLACK & BRO.,  
Springfield, Vt.Carbonized Stock  
a Specialty. **FLOCKS**Established  
1870.**JAMES PITTS & SON.**Long Distance Tel.  
255-3.

MANUFACTURERS OF

**FINE  $\Delta$  STANDARD  $\Delta$  ALL - WOOL  $\Delta$  FLOCKS,**

Lights in any Shade Required.

Dark and Light Mixtures to Match any Goods. Brown and Fancy Mixtures for Piece Dyed Goods.  
Blacks and Blues of Fast Colors.

P. O. Address,

FORESTDALE, R. I.

Telegraph, Express and Freight Address,  
BLACKSTONE, MASS.**WM. B. CHARLES,**  
**HIGH GRADE COTTON AND COTTON WASTES,**  
**AMSTERDAM, N. Y., U. S. A.**

We have our own cotton buyers at Southern points, thereby guaranteeing full grade shipments. Contracts made with Cotton and Woolen Mills for yearly waste production. Stock for Bating purposes. Cable address, "CHARLES" Shepperson's Code 1878.

*Correspondence Solicited.***CHARLES. W. BECKER, Agent.**

MANUFACTURER OF

**Cotton Shoddies, Wool Shoddies**

and Merino Shoddies in White and Color.

DEALER IN

Wool, Noils, Cotton, Cotton Waste, Hosiery Clips, Etc.

Buy for spot cash all kinds of Waste from Cotton, Woolen,  
Worsted, Hosiery and Underwear Mills.**CUSTOM DEPARTMENT.**

Custom Carbonizing, Neutralizing and Dusting Wool, Noils and Woolen Rags.

Custom Picking and Garnetting Hosiery and Woolen Mill Stock.

Correspondence Solicited.

**AMSTERDAM, N. Y.**

Address Dept. 7.



# STOUGHTON MILLS, West Stoughton, Mass.

R. BROOMFIELD, Treas.

Manufacturers of

## Wool Shoddies.

Carbonized Stock  
a Specialty.

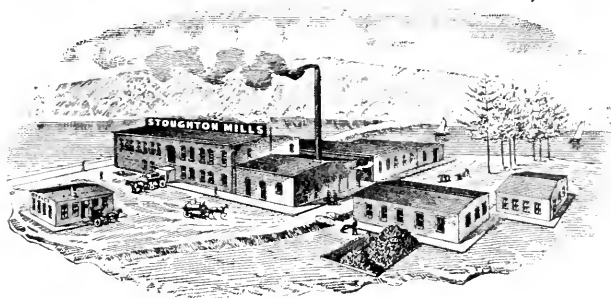

Boston Office, 170 Summer St.,

opposite South Station.

Telephone 4182 Main.

Miller, A. H., 563 Atlantic Ave., Boston, Mass.

Mohawk Mfg. Co., Oswego, N. Y.

Morrison, O. & E. G., Tilton, N. H.

Mullineaux, Clegg & Co., Chatham Mill's, Howard and Berks Sts., Phila., Pa.

Norfolk Woolen Co., Franklin, Mass. Sell direct.

Ogden, Chas. H., Springvale, Me.

Onalaska Woolen Mfg. Co., The, Onalaska, Wis.

O'Neill Bros., Howard and Columbia Aves., Phila., Pa.

Paterson Wool Extract Co., Paterson, N. J.

Pease, Herbert, No. Vassalboro, Me.

Pendergast, Daniel, Franklin, Mass.

Pittsburg Waste Co., 3127 Penn. Ave., Pittsburg, Pa.

Riverdale Woolen Co., Northbridge, Mass. Sell direct.

Saeltzer Woolen Co., The, 71-75 Leyeden St., Cleveland, O.

Sibley, Wm. H., No. Windham, Conn.

Silurian Mills, Newton Lower Falls, Mass.

Slack, W. H. H. & Bro., Springfield, Vt.

Smith & Cooley, Stafford Springs, Conn.

So. Acton Woolen Co., So. Acton, Mass.

Southern Shoddy Mills, Rossville, Ga.

Southern Waste Works, Ltd., 16th and Carpenter Sts., Phila., Pa.

Stoughton Mills, West Stoughton, Mass.

Sullivan, R. T., Co., Newton Lower Falls, Mass. Sell direct through Boston office.

Taylor, Herbert G., 1809 Russell St., Phila., Pa.

Taylor Bros., 84 Mill St., Germantown, Pa.

Tracy, E. A., So. Coventry, Conn.

Troy Waste Mfg. Co., Cohoes, N. Y.

United Waste Mfg. Co., 145 River St., Troy, N. Y.

Wallworth, J. & Sons, Upland, Pa.

Walter, F. W. & Co., Nicetown Mills, Nicetown, Pa.

Waterhouse, John, 47 Borden St., Providence, R. I.

Welch-Gleason Mfg. Co., Quinapoxet, Mass.

Western Wool Mfg. Co., San Francisco, Cal.

Whipple, J. L., Los Angeles, Cal.

Wilson, Herbert M., Bridgeton, R. I.

Windle, A. D. & W. W., West Millbury, Mass.

Worcester Dusting Mill, Worcester, Mass.

Wright, Wm. L., Rear of 4129 Germantown Ave., Phila., Pa.

### Flocks.

Becker, Chas. W., Amsterdam, N. Y.

Gould Mfg. Co., Shirley, Mass. Sell direct.

Lee, D. M., Uxbridge, Mass. Sell direct.

Lowenthal, W. & Co., Cohoes Shoddy Mill, Cohoes, N. Y.

Millbury Scouring Mill, West Millbury, Mass.

Pitts, James & Son, Millville, Mass. Sell direct.

Rawitser, S. & Co., 257 Water St., Brooklyn, N. Y.

Rich, John S., Millbury, Mass. Sell direct.

Riverdale Woolen Co., Northbridge, Mass.

Slack, W. H. H. & Bro., Springfield, Vt.

**DANIEL I. MURPHY,** ·WHOLESALE·  
**Woolen Rags,**  
 TELEPHONE 5499-A. OFFICE AND WAREHOUSE,  
 CORRESPONDENCE SOLICITED. 39 No. WATER ST.,  
 PHILADELPHIA.

JOHN H. LYON.

PHILIP M. KNIGHT.

JOSEPH C. TULLY.

**JOHN H. LYON & CO.,**

DEALERS, GRADERS AND PACKERS

**OLD AND NEW WOOLEN RAGS. WOOL AND WASTE.**

174 Duane Street, New York.

**The Lamport Manufacturers' Supply Co.**

Wholesale Dealers in

**Cotton and Woolen Remnants and Seconds.**Cotton and Woolen Rags.  
Cotton and Woolen Waste.**Bleachery and Print Works Waste a Specialty.**

Branch, Passaic, N. J.

67 ELDRIDGE STREET.

Headquarters, NEW YORK

**JOHN J. CONNELL,** ...DEALER IN...**Cotton & Wool, Cotton & Wool Waste**

SHODDIES and FLOCKS,

No. 239 North Front Street,

PHILADELPHIA.

Telephone Connection.

Correspondence solicited.

**REIS & CO.,**

Buyers and Dealers in

**COTTON, LINTERS AND PICKINGS.****CONTRACTORS FOR COTTON MILL WASTE.**

Importers of Gunny Bagging, Thread Waste and Paper Stock.

620 Atlantic Ave.,  
Boston, Mass.Heidelberg,  
Germany.

RICHARD J. MAYER, General Manager.

**W. WOLF & SONS,**

—DEALERS IN—

**Cotton and Cotton Waste, Linters, Pickings, Etc.**

620 Atlantic Ave., Boston, Mass.

Stuttgart, Germany.

ADOLF LEVE, Boston, Mass., Gen'l Manager for the U. S.

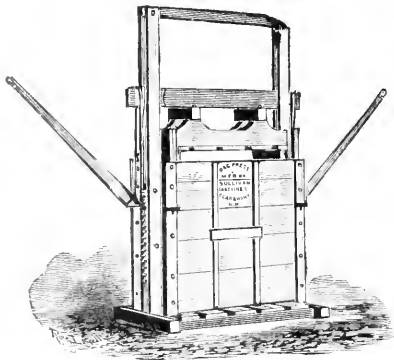
**SULLIVAN MACHINERY CO.**

100 Main Street, Claremont, N. H.

Chicago Office: 135 Adams St.

Manufacturers of

**Hand Power Baling Presses,**For Baling Cotton, Waste, Paper Stock, Rags,  
Card Board, Soft Metals, Etc.

These presses make neat firm bales, are well made and durable and are sold at moderate prices. Sullivan Presses are largely used by the cotton and paper mills and by stock dealers. Write us for circulars and prices.

**WHOLESALE RAG DEALERS.**

The following list comprises the principal Wholesale Rag Dealers in the United States who have dealings with the textile industry.

**Amsterdam, N. Y.**

Charles, William B.

**Baltimore, Md.**

Baker, N. & Son, 6 West Lombard St.  
 Beever, John R., 1113 Hillen St.  
 Blerau, Conrad, 300 N. Ann St.  
 Bohager, F. R. & Co., 227 Concord St.  
 Bowman, Wm., 1327 Eastern Ave.  
 Broderick Bros., 608 W. Pratt St.  
 Clifford, Thomas L., 1033 Hillen St.  
 Dallrymple, J. R. & Co., 28 Centre Market St.  
 Durny, J. T., 141 S. Poppleton St.  
 Fenton, M. C., 18 West Pratt St.  
 Frank, Nathan & Sons, 1402 Mulliken St.  
 Hoopes & Radford, 1018 Ashland Ave.  
 Horner, M. T. & Co., 1018 Atlantic Ave.  
 Kent, Henry B., 219 Pearl St.  
 Wailles, James T., 1017 Hillen St.  
 Winternitz, Samuel G., 214 So. Howard St.  
 Wolf, Marcus W. & Co., 204-206 German St.  
 Woolford, N. B., 916 S. Broadway.

**Binghamton, N. Y.**

Moody & Gould Co.

**Boston, Mass.**

Adams Bros., 571 Atlantic Ave. (See also cotton).  
 Bishop, Robert, 157 W. Sixth St.  
 Butler, Thos. & Co., 23 Medford St.  
 Butterworth, Edwin & Co., 58 Federal St; importers.  
 Chase, T. E., 165 A St.  
 Corbett, W. J. & Co., 239-241 A St.  
 De Vito, John A., 233 Commercial St.  
 Dillingham, I. S., 64 Federal St.  
 Dutton, Horace & Co., 161 Franklin St. (See also wool).  
 Emerson, A. & Co., 653 Atlantic Ave. (See also cotton).  
 Feinberg, Wm. A. & Co., 97 Lowell St.  
 Foss & Co., 500 Atlantic Ave. (See also wool).  
 Goldstein, B., 102 Fulton St.  
 Graham, James, 43 India Sq.  
 Gray, T. H. & Co., 170 Summer St. (See also wool).  
 Hamburger Bros., 319A Congress St.  
 Hill & Cutler, 567-569 Atlantic Ave. (See also cotton).  
 Hodgkins, O., Commercial Wharf.  
 Keenan, John, 17 Richmond St.  
 Keenan, P. J., 56 Fulton St. (See also wool).  
 Klous, I., rear 475 Atlantic Ave.  
 Lodge, J. T. & Co., 555 Atlantic Ave. (See also wool).  
 McNaught, W. W., 465 Atlantic Ave. (See also wool).  
 Norton, M. J., Commercial Wharf.  
 Remick, T. & Co., 489 Atlantic Ave. (See also wool).  
 Train, Smith & Co., 24 Federal St; Importers.  
 True & McClelland, 64 Federal St; Importers.  
 Vinal, S. S. & Co., 52 India St.  
 Yates & Co., 7 Doane St.

**Bridgeport, Conn.**

Gledhill & Co., 279 Water St.  
 Rogers, M. H., 23 Washington Ave.

**Brooklyn, N. Y.**

Gatti-McQuade Co., 246 Bedford Ave.  
 Hughes & Bro., 90 Metropolitan Ave.  
 Murphy, Patrick, 345 Lorimer St.  
 Tierney, J., 254 Hudson St.

**Buffalo, N. Y.**

Fass, J. & Co., 320 Spring St.  
 Fox, M. & Co., 154 Terrace St.  
 Hayman, M. & Co., 154 Terrace St.  
 Hofeller, T. & Co., 100 Terrace St.  
 Loeser, W. L., 120 Church St.  
 Oppenheimer & Co., 152 Oak St.  
 Robinson, D. W., 99 Washington St.  
 Ullman, D. & Sons, 237 Van Rensselaer St.

**Charleston, S. C.**

Lynch, P. F.  
 Miller, W. L.

**Chicago, Ill.**

Armidano & Damato, 84 Sherman St.  
 Birkenstein, S. & Sons, 48 Michigan St.  
 Brun, Wilhelm, 1579 39th St.  
 Burns, Nicholas; Roberts, near Huron St.  
 Carpenter, Geo. B. & Co., 202 S. Water St.  
 Chapman & Son, 553 S. Canal St.  
 Doppelt, J., 79 Franklin St.  
 Ex, D. L., 332 S. Paulina St.  
 Felsenthal, Benj., 339 Fifth Ave.  
 Felsenthal, D. I. & Co., 409 So. Canal St.  
 Fine, Louis, 1745 W. 47th St.  
 Gaudiano, Pasquale, 242 West Taylor St.  
 Gaudiano, P. Paper Stock Co., 242 West Taylor St.  
 Goodman, Meyer I., 568 So. Canal St.  
 Hagen, F. M., 835 Seminary Ave.  
 Harris, Barnett, 179 West Taylor St.  
 Julo, Frank, 230 W. Polk St.  
 Kaufman, M., 200 Michigan Ave.  
 Kramer, Chas. A. L., 237 Randolph St.  
 Lowenthal, E. Bros. & Co., 515 S. Canal St.  
 Miller, Wm., 3167 Washland Ave.  
 Nelson, Soen, rear 158 Gault St.  
 Pioneer Paper Stock Co., 318-324 So. Desplaines St.  
 Rawitscher, Fred, 477 S. Canal St.  
 Sandler, Wolff, 189 W. 14th St.  
 Standard Paper Stock Co., 56, 58 N. Desplaines St.  
 Unger, J., 46 S. Franklin St.  
 Vonder Heide, Claus, 237 Randolph St.  
 Western Paper Stock Co., 1452-1456 Indiana Ave.

**Cincinnati, O.**

Bierich, Ernst, 57-59 Main St.  
 Bowen, Ebenezer, 536 Walnut St.  
 Bugganer, Dominick, & Son, 460 East Second St.  
 Fettig, Jos. & Bro., 1910 Plum St.  
 Gomersall, Bruce, 325-332 East Front St.  
 Hey, Benj., 123 Broadway.

Malsh, Chas. A. & Co, 840-842 West Sixth St.  
O'Connor, T, 55 Race St.  
Winkler, J. & Bro, 36 Main St.

### Cleveland, O.

Arnstein, L. & Co., 120 River St.  
Fishel, Welskopf & Co., 81 Merwin St.  
Koblitz Bros., 145 Water St.  
Koblitz & Kohn, 365 Broadway.  
Stone & Grodin, 6 Columbus St.  
Stone Bros., 28 Merwin St.

### Cohoes, N. Y.

Lowenthal, W. & Co., Remsen St.

### Columbus, O.

Jackson Bros. & Co.  
Peters, G. D.

### Danielson, Conn.

Getty, E.

### Delaware, O.

Bishop Bros.

### Detroit, Mich.

American Paper Stock Co., 111 W. Congress St.  
Davis, Mayer & Co., 259 Winder St.  
Peritz Bros., 76 Macomb St.  
Rumsey Wool Stock Co., 115 E. Fort St.  
Simon, A. & Co., 205 Beaubien St.

### Fall River, Mass.

Cohen, Louis L. & Co., 366 Ferry St.  
Crowley, J. D. & Sons, 189 Anawan St.  
Dunn, Wm. J., 239 Central St.  
Estes, John H. & Son, Stafford Road.

### Fitchburg, Mass.

Wallace, Rodney, 387 Main St.

### Haverhill, Mass.

Roberts, Walter B.

### Hazardville, Conn.

Gordon Bros.

### Indianapolis, Ind.

Cohen, Alex.  
Cohen, H.  
Marks, Henry.

### Lawrence, Mass.

Gutterson & Gould, 508 Common St.

### Limo, O.

Jackson, J. B. & Sons.

### Lowell, Mass.

Riley, P. J. & Co., 48 Summer St.

### Manchester, N. H.

Riley, Peter, 1308 Elm St.  
Rosenberg Bros., rear 1104 Elm St.

### Milwaukee, Wis.

Benesch Bros., 401 Sixth St.  
Hiemke, W. & Son, 409 Third St.  
Lowenthal, R., 55 Third St.  
Ruplinger & Schmidt Co., 27 Johnson St.  
Sadek, J. & Son, 69 Third St.  
Seeboth Bros. & Co, 109 Reed St.

### New Haven, Conn.

Ives, C. W., 219 Water St.

### New York.

Abraman, Jos. H., 11 Lewis St.  
American Remnant Supply Co., 696 Broadway; rags and waste, remnants and seconds.  
Atterbury Bros. (Inc.), 277 Water St.; importers.  
Baldwin, Geo. E., 392 Hudson.  
Baldwin, J. T. & Co, 62 Thompson St.  
Berger, M. & Co., 182 Cherry St.  
Berman, Nathan, 230 W. Broadway.  
Butterworth, Edwin & Co, 132 Nassau St.  
Campbell, Peter C., 12 James Slip.  
Cantasano, Nicholas V. & Bro, 43 Duane St.  
Caputo & Libonati, 376 W. Broadway.  
Castle & Gottheil, 41 Park Row; importers.  
Chase & Norton, 277 Water St.  
Cohen, Julius, 243 Eldredge St.  
Copeland, A. M., 50 Ann St.  
Corrigan, P., 306 E. 38th St.  
Cralg, H. G. & Co. 132 Nassau St; importers.  
Darmstadt & Scott, No. Moore St.  
De Alessandro, Joseph, 61 Thompson St.  
Dietz, Jas. E., 2209 2d Ave.  
Foss, M. J., 32 City Hall Place.  
Gatti-McQuade Co., 89 Crosby St.  
Gilmartin, J., 420 Canal St.  
Hagemeyer & Brunn, 9 Stone St; importers.  
Harley, Chas. Co., 365 East Third St.  
Helnehan Bros., Walker St.  
Hennessey, James, 30 City Hall Pl.  
Hermann, M. & Co., 256 West St.  
Hills, George F., 54 Roosevelt St; importer.  
Jacobs, Kaplan & Co., 62 Thompson St.  
Jaffe & Stromberg, 445 Water St.  
Jessup & Moore Paper Co, 99 Nassau St.  
Kaplan, D. & Co., 7 Rutgers Place.  
Kornblum, Daniel, 146 Spring St.  
Lahn & Simons, 478 Water St.  
**LAMPOR MFGRS. SUPPLY CO., 87 Eldridge St.**  
Leviton, A., 71 Rutgers Slip.  
Libmann, Joseph & Co, 351 West Broadway; importers.  
**LYONS, J. H. & CO., 174 Duane St.**  
Madigan, Maurice, 721 Washington St.  
Maguire, M., 100 Tenth Ave.  
Mason, John W. & Co, 39 Cortlandt St; importers.  
Michaels, D., 63 Crosby St.  
Mitchell, M., 42 Watts St.  
Mutnick, S. & Sons, 12 First St.  
O'Neill, P. F. & Co., 413 E. 124th St.  
Osnowitz, H., 504 W. Broadway.  
Overton, R. H. & Son (Inc.), Times Bldg.; importers.  
Perkins, Goodwin & Co, 66-68 Duane St; importers.  
Pflugner, L., 406 W. 41st St.  
Rau, G., Times Building; importer.

Rawitzer, S. & Co, 285 W. Broadway.  
 Rich, A., 88 Monroe St.  
 Rosenzweig, V., 510 Water St.  
 Sachs & Co, 390 Pearl St.  
 Salomon Bros. & Co., 99 Nassau St.  
 Salomon, Felix & Co., 140 Nassau St.  
 Salus, J, 14 Wooster St.  
 Schofield, G., 12 Lispenard St.

**SERGEANT, J. V. & CO.,** Spuyten  
 Duyvil and 132 Nassau St., New York  
 City.

Shea, Dennis, 506 Pearl St.  
 Sinnott, J., 506 W. 38th St.  
 Smith, Thos. & Sons, 73 Pike Slip.  
 Sommer, T, 321 W. Broadway.  
 Steinberg Bros. 2 First St.  
 Steinfels, H, 327 W. Broadway.  
 Sumner, Chas. P. & Co, 18 Broadway;  
 importers.

Symmers, J, 92 Water St.  
 Train, Smith & Co, 140 Nassau St.  
 Ward, Owen & Sons, 450 W. 39th St.  
 Wertheim, A. & Co, 99 Nassau St.  
 Wilson, J. & Bro., 195 Chrystie St.  
 Wolff, Norbert, 14 Jay St.  
 Woolworth & Graham, 440 Pearl St; im-  
 porters.

Zimmerman, B., 490 Water St.

### Philadelphia, Pa.

Alexander, Adam, 2618 Harold St.  
 Bade, Harry, 1311 Germantown Ave.  
 Badger, Evan G, 2 Decatur and 916 Cher-  
 ry St.

Baldwin, T. H., 909 Federal St.  
 Beaumont, J., 3105 Gray's Ferry Road.  
 Bers, E. & Co., 22 South Delaware St.  
 Brown, Wm., 2342 No. 2d St.  
 Burr Bros., 115 S. Water St.  
 Coll, P. & J, 763 S. 8th St.  
 Corner, Edward, 1030 Beach St.  
 Cunningham, John, 1923 East Huntingdon  
 St.

Dawson, J., 1311 Cherry St.  
 Dodgson, H. & Co., 142 So. Water St.  
 Evans, Sam'l, 1205 So. 27th St.  
 Feldman, H. & Co., 901 So. 6th St.  
 Fenion, William, 144 Poplar St.  
 Flanagan, William A, 106 N. Front St.  
 Flatley, P., 607 Pine St.  
 Gray, James, 5031 Lancaster Ave.

Griffith, Jas. F., 420 Moyer St.  
 Hemingway, W., 241-243 Elbow Lane.  
 Hennings, Frederick., 329 Brown St.  
 Hennings, Rob't, 1301 No. 4th St.  
 Henschel, Oscar, 128 No. Front St.  
 Higgins, James, 1530 American St.  
 Hillborn, Chas, Jr. 35 No. Sixth St.  
 Holland, Rob't, 623 Delancy St.  
 Hughes, J. H., 2320 No. 8th St.  
 Hurley, Samuel, 418 South Front St.  
 Inman, E., 2046 East Susquehanna Ave.  
 Johnson, J., 532 So. Water St.  
 Kenworthy, Thos., & Bro.  
 King, J. D., 112 Walnut St.  
 Kitchen, James G. & Co., 55 No. Front  
 St.

Lee, Charlotte, 2912 No. Front St.  
 Lenhart, J. I., agent, 215 No. Front St.  
 Linton, Josiah & Co., 112 N. Front St.  
 Lynch, Thos., 415 Cherry St.  
 Martin, John C., 1922 West Moreland St.  
 McGrath, John J, 20 Thompson St.  
 McAnulty, John, 2431 No. Hancock St.  
 McKeown, Robert, Swanson & Queene  
 Sts.

Messerschmidt, John, 921 N. 3rd St.  
 Meyer Bros. 234 N. Front St.  
 Miller, F. G., 1748 No. 2d St.  
 Monville, Gilles, 139 N. Front St.  
 Mullin Paper Stock Co. (Ltd.).  
 Murphy, Daniel I., 37 No. Water St.  
 Murphy, M., 532 No. Front St.  
**O'NEIL, PATRICK & CO.,** 408 S. 6th St.  
 Ridsdale, John & Co, 122 N. Front St.

Silverwood, Joseph, 150 N. Front St.  
 Simmons, John & Son, 20-30 Decatur St.  
 Weil, Morris & Sons, 837 No. Third St.

### Portland, Me.

White, James, 12 Portland Pier.

### Providence, R. I.

Bazer Bros., 153 Chalkstone Ave.  
 Blanding, C. L. Mfg. Co., 48 Exchange  
 Place.

Evans, F. B, 41 Canal St.  
 Hunt, E. R.  
 Hunt, F. A., 27 Fountain St.  
 Klein, Simon, 36 Kane St.  
 Peck, Asa A., 536 Atwells Ave.  
 Priest Bros., 353 Canal St.  
 Thornley, Richard, 17 Exchange Place.  
 Winograd, Morris, & Son, 1 Lopez St.

### Reading, Pa.

Grleshaber Bros, 832 Franklin St.  
 Luria Rag Co., 247 Poplar St.

### Rochester, N. Y.

Cohen, J, 97 St. Joseph St.  
 Frankel, Chas. & Co., 66 East Sellinger  
 St.

Hey, Levi Co, 351 State St.  
 Levi, B., Sons, 109 St. Joseph St.  
 Lipskey, I. & Co, 10 Herman St.

### St. Louis, Mo.

Berger, J. & Co, 1926 W. Broadway.  
 Bierman, F, 1223 N. 12th St.  
 Bradley, C, 906 W. Iron St.  
 Klauber, B. & Sons, 810 Biddle St.  
 Levitt, M, 1215 N. 8th St.  
 Mathes' Sons Rag Co., N. 7th St.  
 Mayer, A. B. Mfg. Co, 1012 N. 12th St.  
 Mayer, M. & Son. 620 S. 7th St.  
 Schwartz, S., 1219 N. 8th St.

### Syracuse, N. Y.

Eddy, E. J, 629 N. Salina St.  
 Fisk, C. H, 1920 Park St.  
 Rabinawitch, I. & Co., 925 Slater St.  
 Randall, L. S, 227 Gazelle St.  
 Syracuse Rag Co, 714 E. Water St.

### Troy, N. Y.

Ryan, John J., 145 River St.  
**Troy Waste Mfg. Co.** 432 River St.  
 White & Muffson, 409 River St.

### Worcester, Mass.

Buxton, E. & Son, 13 Southgate St.  
 Edinburg, Ida (Mrs.), 16 Brown St.  
 Hubley Mfg. & Supply Co., 11 Brackett  
 Court.

Hull, Sam'l E., 112 Front St.  
 Kilton, W. S. & Co., 30 Shrewsbury St.  
 Kumin Bros., 61 Water St.  
 Stead, Henry, 19 Segel St.  
 Thurman, James, 586 Worcester St.  
 Worcester Rag Warehouse Co, 10 Brack-  
 ett Court.

# RAW MATERIALS

LIST OF

Dealers and Brokers in the Principal Cities.

## WOOL DEALERS.

### Albany.

Barnet, Wm. 164 Broadway.  
Blatner, B., 164 Broadway.  
Graves, Frank B., 14 Bleecker St.  
Hamburger, D. J. & Sons Co.  
Newman, Chas. & Co., 457 Broadway.  
Safford & McNamara, 13 State St.

### Allegheny, Pa.

Fisher & Simon; pullers.  
Franz, Conrad.  
McGraw, Patrick & Co., 340-5 River Ave.

### Amsterdam, N. Y.

Charles, Wm. B.

### Aurora, Ill.

Aurora Wool Scouring Mills; dealers.  
Salesrooms 151 Kinzie St., Chicago,  
Ill.

### Baltimore.

Baer, Lewis & Co., 206 Light St.; also cotton; also Norfolk and Newport News, Va.  
Blustein, I. & Co., 512 Light St.  
Chipchase Bros., 224 S. Charles St.  
Higgins & Waters.  
Marcus, Henry & Son, 30 S. Calvert St.  
Norris, W. E. & Co.  
Rosenburg, Hupp & Siegel.

### Boston.

Anthony, Geo. L. & Co., 620 Atlantic Ave.  
Bateman, W. R., 168 Congress St.; broker.  
Berryman, R., 620 Atlantic Ave.  
Blanchard, W. A., 191 Summer St.; pulled wools.  
Booth, Ernest, 143 Federal St.; broker.  
Boutwell, J. P., 143 Federal St.; broker.  
Boyce & Page, (successors to Bond, Geo. Wm. & Co.), 620 Atlantic Ave.; brokers.  
Brackett, I. Lewis & Co., 206 Summer St.; broker.  
Brown & Adams, 274 Summer St.  
Brown, Walter & Co., 620 Atlantic Ave.  
Carlton, E. B. & Co., 620 Atlantic Ave.; dealers and brokers.  
Clark, R. B. & Co., 230 Congress St.  
Clementson, Sidney & Co., 198 Summer St. brokers.  
Clifford, A. H., 143 Federal St.; broker.  
Coffin & Son, 620 Atlantic Ave.; brokers.  
Cordingley, W. S. & Son, 559 Atlantic Ave.; also waste and shoddy.  
Cotton, Geo. C., 185 Summer St.; broker.  
Crimmins & Pierce, 127 Federal St.; successors to Hutchins & Co.  
Cross, Chas. F. & Co., 175 Purchase St.  
Daly, James E., 620 Atlantic Ave.; shoddies and extracts.  
Denny, Robt. B., 143 Federal St.; broker.  
Denny, Rice & Benedict, 610 Atlantic Ave.  
Dewey, Gould & Co., 600 Atlantic Ave.  
Dobson & Wilde, 216 Summer St.  
Dodd & Co., 620 Atlantic Ave.

Dutton, Horace & Co., 161 Franklin St.; wool stock.  
Dupee, Frank, 200 Summer St.; broker.  
Eisemann Bros., 200 Summer St.; dealers.  
Farrell, John L., 210 Summer St.; broker and dealer.  
Fisfield, H., 170 Summer St.; broker.  
Finnigan, John & Co., 235 Congress St.; F. R. Palmer, agt.  
Filtner, F. W., 184 Summer St.; broker.  
Follett, Albert G., 185 Summer St.; broker.  
Follett Wool Co., 214 Summer St.  
Forino Co., 620 Atlantic Ave.; foreign.  
Foss & Co., 500 Atlantic Ave.; also wool stock.  
Fowle, J. A., 170 Summer St.; broker.  
Garfield Woolen Mills, 177 Purchase St.; shoddy.  
Garrity & Co., 220 Purchase St.; brokers.  
Goodhue & Studley, 562 Atlantic Ave.  
Grant, H. C., 620 Atlantic Ave.  
Graves, F. N. & Co., 620 Atlantic Ave.; dealers.  
Gray, T. H. & Co., 170 Summer St.; shoddy and waste.  
Hall, E. A., 170 Summer St.; dealer.  
Hallowell, Donald & Co., 252 Summer St.  
Harding & Caverly, 286-288 Summer St.  
Harding, Louis B., 620 Atlantic Ave.; broker.  
Harkness, Chas. B., 556 Atlantic Ave.; broker.  
Hartley, F., 612 Atlantic Ave.; importers.  
Hartley, H., 620 Atlantic Ave.; dealer.  
Harrington, Geo., 212 Summer St.  
Harris, Wm. H., 182 Summer St.; broker.  
Hawley, R. B. Jr., 624 Atlantic Ave.; broker.  
Hecht, Liebman & Co., 280-284 Summer St.; dealers.  
Heckman & Son, 248 Congress St.  
Hendry, Geo. H. & Co., 143 Federal St.; brokers.  
Henry, W. S. Jr. & Co., 620 Atlantic Ave.; dealers.  
Hills & Nichols, 153 Summer St.; dealers.  
Hobbs, Taft & Co., 18 Matthews St.  
Hyde & Fitz, 246 Congress St.; dealers.  
Jackson & Moore, 200 Summer St.  
Jonas & Stetson, 157 Summer St.  
Jonas, I. L., 620 Atlantic Ave.  
Keenan, P. J., 56 Fulton St.; wool stock.  
Kenyon, Frederic M., 620 Atlantic Ave.  
Koshland, J. & Co., 268 Summer St.  
Leeds, E. F., 220 Devonshire St.; broker.  
Leonard, H. S. Co., 176 Federal St.  
Lewis, E. Frank, 143 Federal St.; scourer.  
Lissberger, E., 620 Atlantic Ave.  
Lodge, John T. & Co., 555 Atlantic Ave.; waste.  
Lothrop & Worthington, 198 Summer St.  
Luce & Manning, 138 Federal St.; dealers.  
Macomber, F. M., 143 Federal St.; broker.  
Mauger & Avery, 564 Atlantic Ave.; brokers.  
McCarty, Dan J., 56 Fulton St.; dealer.  
McKissack, James, 28 High St.  
McNaught, W. W., 465 Atlantic Ave.; also tags, etc.  
Miller, A. H., 562 Atlantic Ave.; also shoddy.  
Mint, Walter, 26 Ex Place.  
Murfit, S. C., 237 Congress St.  
Nichols, Dupee & Co., 262 Summer St.  
Norton Scouring Mills, 624 Atlantic Ave.; scourers.

Olney, Richard, 275 Congress St.; broker.  
 Parsons Bros., 560 Atlantic Ave.; successors to Henry & Parsons.  
 Paton, James H., 200 Summer St.; broker.  
 Patterson & Company, 568 Atlantic Ave.; dealers.  
 Perkins, F. Nathaniel, 620 Atlantic Ave.; dealer.  
 Purdy, O. N. & Co., 290 Summer St.; dealers.  
 Reed, W. H., 157 Federal St.; broker.  
 Remick, T. & Co, 489 Atlantic Ave.; also cotton.  
 Ross, John, 620 Atlantic Ave.; dealer.  
 Root, G. & Co., with E. B. Carleton & Co., 620 Atlantic Ave.  
 Salter Bros. & Co., 212 Summer St.; brokers.  
 Salter, Chas. G., 176 Federal St.  
 Schmidt, C. E., 237 Congress St.  
 Schmidt, Traugott & Sons (Detroit, Mich.), 620 Atlantic Ave.; dealers.  
 Shattuck, F. R., Jr., 200 Summer St.  
 Silberman Bros., 200 Summer St.  
 Simonds, H. & F. P., 200 Summer St.  
 Smith, Albert W. & Co, 125 Federal St.; dealers.  
 Smith, Dwight, 210 Purchase St.; waste and hocks.  
 Snow, Geo. W. & Co., 560 Atlantic Ave.  
 Solis & Co., 620 Atlantic Ave.; broker  
 Solis, Jefferson & Co., 620 Atlantic Ave.  
 Staudt & Co., 620 Atlantic Ave.  
 Stoddard, Haserick, Richards & Co, 152 Congress St.; importers.  
 Stone, Timlow & Co, 237 Congress St.; pulled wool.  
 Sullivan, R. T., 200 Summer St.; shoddy and extract.  
 Swift Wool Co. (Chicago, New York and Philadelphia), 620 Atlantic Ave.; pulled wool.  
 Thacher, T. C. & Co., 16 Pearl St.; also cotton.  
 Tuckerman, Francis F., 620 Atlantic Ave.  
 Varney, F. A., 530 Atlantic Ave.; dealer.  
 Wall, Wm. E., 620 Atlantic Ave.; dealer, also waste.  
 Watson, H. J., 620 Atlantic Ave.; dealer.  
 Webster, Richard, 235 Congress St.; broker.  
 Wheelock, J. H. & Co. (foreign) 620 Atlantic Ave.; brokers.  
 White, Otis & Co., 212 Summer St.  
 Whitman, Farnsworth & Thayer, 118 Federal St.; dealers.  
 Wilcock & Cordingley, 570 Atlantic Ave.; dealers and commission.  
 Willett, Geo. F. & Co, 147 Federal St.; dealers.  
 Willey, F. & Co., 556 Atlantic Ave.; dealers.

Williams & Smith, 212 Summer St.; dealers.  
 Williams, H. R., 562 Atlantic Ave.  
 Williams, Jeremiah & Co., 300 Summer St.; dealers.  
 Winslow Bros, 147 Federal St.; pullers.  
 Woodbury, A., 12 Federal St.; broker.  
 Wood, Jacob H. & Co, 620 Atlantic Ave.; dealers.  
 Woods, Arthur L., 620 Atlantic Ave.; broker.  
 Wright, John G. 620 Atlantic Ave.; dealer.  
 Wyman, Franklin A, 101 High St.; dealer.  
 Yerrington, Wendell P, 6 Leather Sq; dealer.

**Buffalo.**

Buethner & Schrowe.  
 Heintz, G. M., 862 Babcock St.  
 Krauss, A. & Co.  
 Wolff, Nathan, 32 Lloyd St.

**Chicago.**

Allen, W. A. Wool Commission Co, 189 Michigan Ave.  
 Armour & Co, 205 La Salle St.  
 Bach, Becker & Co, 107 Michigan St.  
 Carstairs, A. M. & Co., 137 Kinzie St.  
 Case, G. J., 44 N. Clark St.  
 Coffin & Dodd, 128 Michigan St.; see Boston, Mass.  
 Dreyfus, J, 212 Michigan Ave.  
 Graham, J. H. & Co., 137 Kinzie St.  
 Harrington & Co., C. H., 151 Kinzie St. (Aurora Wool Scouring Mills.)  
 Howard, J. H., 809 Chamber Commerce Bldg.  
 Johnston, James; F. W. Johnston, Agt.; 62 N. Clark St.  
 Kellogg, Hudson H., 199 Kinzie St.  
 Lewis, A. M. & Co., 146 Kinzie St.  
 Miller, John & Co, 121 Michigan Ave.  
 Popper, L. & Co., 106 Michigan Ave.  
 Porter, F. C., 131 Kinzie St.  
 Sayers, B. W., 239 Kinzie St.  
 Schoenen, Harry C., 130 Michigan St.  
 Silberman Bros., 122 Michigan St.; also Ottumwa, Iowa.  
 Stevens, F. K., 806 N. Paulina St.  
 Swift & Co, Stock Yard; pullers.  
 Thompson, H. T. & Co, 201 Michigan St.  
 Thornton, W. H. B., 6 N. Clark St.  
 Weil, Isaac, 141 Kinzie St.; also Ottawa and Streator, Ills.  
 Weil & Eisendrath, 413 N. Halsted St.

**Cincinnati.**

Greenebaum, S. & Co, 1644 Central Ave.  
 Ohio & Kentucky Kid Leather Mfg. Co, 1644 Central Ave; pullers.

Brushed AND Scoured Pulled Wool.

SWIFT AND COMPANY.

BOSTON OFFICE:

SWIFT WOOL COMPANY, HATHAWAY BUILDING.

Long Distance 'Phone 1254.

**Geo. F. Willett & Co., Inc.**

**DOMESTIC AND FOREIGN WOOL.**

New York Office, Wool Exchange Bldg.

147 Federal St., BOSTON.

Reehl, Thomas, 1934 Plum St.  
Straus & Co, 52 Main St.  
Wise, L. & Bros, 36 Main St.

### Cleveland.

Burt, S. H. & Co.  
Collings, Taylor & Co, Cedar and Central  
Aves; shoddies.  
Mittelberger, M. & Son.  
Muehlhausen, A. & Son.

### Detroit.

Beck, L. H. & Sons, 304 East High St.  
Behr Bros, 353 Graftot Ave.  
Caughey & Carran.  
Schmidt, Carl E, 64 Macomb St.  
Schmidt, Traugott & Sons, 138 Monroe  
Ave.  
Sloman, M. & Co, 17 Telegraph Block.

### Galveston, Tex.

Flinnigan, John, & Co.  
Portier, C. G. & Co.

### Grand Rapids.

Cappon & Bertsch Leather Co; pullers.  
Klefer, Edgar S.  
Perkins & Hess.  
Welden, H. & Son, 38 E. Bridge St.

### Hartford, Ct.

Beach & Co, 209 State St.  
Dwight, H. C. & Co., 207 Allyn St.  
Judd, H. C. & Root, Cor. High & Allyn  
Sts.  
Kellogg, N. O.  
Sage, E. W. & Co, 64 Albany Ave.

### Helena, Mont.

Montana Hide Co.

### Indianapolis.

Merritt, Geo. & Co.; also woolen mfrs.

### Kansas City, Mo.

Biggs & Koch, 1417 St. Louis Ave.  
Lyon, M. & Co., 102 W. 3d St.  
Stephens Bros., 409 Delaware Ave.

### Lexington, Ky.

Brent, C. S.  
Heacox, Lester & Sons.  
Speyer & Sons.

### Louisville, Ky.

Davis, D. & Son, 127 Main St.  
Dinkelspell's, Samuel Sons, 232 Brook St.  
Hopkins, Wm. 100 Buchanan St.  
Rosenbaum, Isaac, & Sons, 321 E. Mar-  
ket St.  
Sabel, M. & Sons, 233 E. Market St.  
Werdinger, M. & Co, 721 East Market St.

### Manchester, N. H.

Gerrish Wool & Leather Co.

### Mexico, Mo.

Mcrris, Sam.

### Milwaukee, Wis.

Bach, Jacob, & Co., 1136 Forest Home  
Ave.  
Karger Bros, 937 Central Ave.  
Lippert, Henry H, 133 W. Water St.  
Milwaukee Produce Co, 120 W. Water St.  
Rosenberg & Liberman, 104 W. Water St.  
Schram, Wm. J. & Co, 122 W. Water St.  
Tewles, L. & Co, 122 W. Water St.

### Mobile, Ala.

Metzger Bros., 20 S. Commerce St.  
Michael, M. & Co., 118 S. Commerce St.  
Piser, Henry & Co, 109 N. Commerce St.

### Napa, Cal.

Sawyer Tanning Co.; pullers.  
Zacharousky, N.

### Nashville.

Bissinger, Max.  
Cline & Bernheim.  
Gilbert, J. E. & Co.; also cotton.  
Lefkovitz, J. & Co.  
Martin, N. & Co.

### Newark, N. J.

Basch & Greenfield Co., 28-46 Sumner  
Ave.

### New Orleans, La.

Alder, Edw. & Co.  
Chapman, W. W., 627 S. Peters St.  
Fitzpatrick, Cromwell Co., Ltd., 616 Com-  
merce St.  
McShane, Andrew J., 630 Commerce St.  
Raquet, Fred, 609 S. Peter St.

### New York.

Bach, Becker & Co, 104 Greene St.  
Cass, Frederick, Coffee Exchange; broker.  
Cilley, J. L., 101 Gold St.  
Denby, Isaac, Wool Exchange.  
Follett Wool Co, Wool Exchange Bldg.  
Groedel, C. H., Wool Exchange Bldg.;  
importers.  
Harrington, J. J. & Co, 770 First Ave;  
pullers.  
Hartley, F., Wool Exchange. (also Bos-  
ton.)  
Higgins, T. H, Wool Exchange Bldg;  
broker.  
Kitching & Blecknell, 55 Dey St; brokers.  
Kitching, F. E., 56 Pine St.  
Kitching, T. E., 13 William St.  
Linnane, M. H, 149 Duane St; broker.  
Lissberger, E., Wool Exchange.  
Lobsitz, Samuel, 253 Church St.  
Lyon, John H. & Co., 174 Duane St.  
Mauger & Avery, Wool Exchange Bldg.;  
brokers.  
McMurtry, J. E, Wool Exchange.  
Mote, H. & Son, 66 Beaver St.  
Oelrichs & Co, 2 Bowling Green; impor-  
ters.  
Payne, Wm. R. & Co, 105 Reade St.  
Polhemus, James S, Wool Exchange.  
Primrose, J. & Co., Broad Exchange  
Bldg.  
Rawitser, S. & Co, corner Canal and W.  
Broadway; rags, wool waste and  
shoddy.  
Ritchie, Geo. B. & Co, 57 Ferry St; also  
hair.  
Salter, Chas. G., Wool Exchange Bldg.;  
brokers.



Scanlan, J. M. & P, 613 West 40th St; pul-  
lers.  
Simon & Kaufman, 622 W 47th St; pul-  
lers.  
Souls, William, 260 West Broadway;  
wool, noils, waste, shoddy, flocks, etc.  
Stone, Timlow & Co.  
Switt Wool Stock Co., Wool Exchange.  
Thompson's, Samuel, Nephew & Co, 142  
Duane St.  
Tierney, Frank A., Wool Exchange.  
Tompkins, C. W., 2 Walker St.  
Weaver, H. S., 134 West Broadway.  
Willets, Geo. F. & Co., Inc., Wool Ex-  
change.  
Wood & Payson, 64 Pine St.  
Wood, James H., Wool Exchange Bldg.

**Norwich, Conn.**

Bliss, Fred G, 35 Shetucket St; also waste.  
Brewster, N. & Son, 35 Shetucket St.  
Carroll, L. W. & Son, 17 Water St; also  
cotton.  
Hall Bros, 29 Commerce St.

**Pendleton, Ore.**

Pendleton Wool Scouring & Packing Co.

**Philadelphia.**

Akeroyd, Alfred, 103 Chestnut St.  
Allen, Wm. F. & Co, 132 N. Front St.  
Ashton, Jas., 2619 Collins St.; waste.  
Beaumont, J. E., 41 Letitia St.  
Bigelow & Wolstenholme, 26 and 28 Leti-  
tia St.; also Boston.  
Brown & Reece, 105 Chestnut St; broker.  
Browne, Wm. & Sons, 10 Letitia St.  
Bullock Bros, 106 Chestnut St.  
Burnley, John B., 236 Chestnut St.;  
waste.  
Clegg, Thos., & Co., Howard & Berks  
Sts.; shoddy.  
Coates Bros., 127 Market St.  
Coffin & Dodd, 22 Letitia St.; broker;  
see Boston.  
Collins, J. J., 105 Chestnut St.  
Connell, John J, 239 N. Front St; wool  
and cotton waste, shoddy, flocks, etc.  
Cooper, H. L, 8 N. Front St.  
Cooper, John W. 49 N. Front St; broker.  
Corr & Bro, 1956 N. 2nd St; waste.  
Crompton, Thos, 247 N. Front St; waste.  
Crosland's, Enos, Sons, 69th St. and  
Haverford Ave.  
Cunningham & Seal, corner Front and  
Arch Sts; brokers.  
DeLong & Coffin, 111 No. Front St.; wool  
and hair.  
Devlin, John, 916 York St; waste.  
Doster, Rob. O., 17 No. Front St.  
DuBree & Akeroyd, 134 So. Front St.  
Fish, Jas, 1910 E. Letterly St.  
Fiske, Louis S., 55 Letitia St.  
Fisler, John, & Co, 110 Chestnut St.  
Flanagan, Wm. A, 106 N. Front St.  
Fowles & Co, 106 Church St.  
French, Hugh, & Sons, 2514 N. Third St;  
waste.  
Ft. Wayne Sheepskin & Wool Co., 130  
Chestnut St.  
Geisse, Henry A, 105 Chestnut St.  
Gibbons, J., 31 No. Front St.  
Greenwood, L, 121 N. Front St.  
Gregg Bros., 18 No. Front St.  
Grubnau, Carl, 30 N. Front St.  
Hagy, J. M. 109 N. 22nd St.  
Hammer, Wm. G. & Co., 17 N. Front St.  
Hartley, Fred, 30 Letitia St; broker.  
Hayes & Co., John J., 47 North Front St;  
wool, noils and waste.  
Henry, Thomas, & Son, 118 Arch St;  
waste.  
Hepworth, Wm. & Son, 103 Chestnut St.

Heston, H. B. & Co, 118 Chestnut St.  
Hey, E. & Co., 31 No. Front St.  
Hoffman, Corkran & Co, 415 Market St;  
yarns.  
Hoffman, Geo. E, 248 Chestnut St; waste.  
Hongler & Bready, 105 N. Water St.  
Hooper Seving & Co, 428 Market St.  
Jagode, Phillip & Co, 14 Letitia St.  
Jennings, Wm., 17 N. Front St.  
Justice, Bateman & Co, 122 S. Front St.  
Kelly, Francis, 1734 N. Hancock St.  
Kempf Bros, 2616 Martha St.  
Kenworthy, T. & Bro., 111 Church St.  
Kenworthy's, Thos. Sons, 130 Arch St.  
Kitchin, James G. & Co, 53 N. Front St.  
Ledger, George J, 41 N. Front St.  
Lee & Bacchus, 13 Letitia St.  
Leslie, John A. & Co, 108 Chestnut St.  
Lewis & Grove, 119 Chestnut St.  
McCann, P., 1718 No. Second St.; cotton  
and woolen waste, yarn and paper  
stock.  
McCloskey, J. J, 34 N. Front St; waste.  
McCullough, Jas. A, & Co, 71 N. Front St.  
McDonnell, J., 100 Chestnut St.  
McGrath, John J, 20 Thompson St.  
McKenna, T, 2005 Hancock St.  
Merritt, James R., 38 No. Front St.  
Mullineaux, Clegg & Co.; wool shoddy.  
O'Neil, Chas, 57 N. Front St; also cotton.  
O'Neil Bros, Columbia Ave. and Howard;  
waste.  
Oelbermann, Wm. B., 11 No. Front St.  
Pancoast, Bird S, 38 No. Front St.  
Patton, G. W. & Co., 38 No. Front St.  
Quicksail, Harvey Q., Frankford; waste.  
Ragg, H. H. & Co, 18 Letitia St.  
Reifsnnyder, I. Son & Co, 110 S. Front St.  
Renaut, L, 256 So. 4th St; brokers.  
Ritchie, Geo. P. & Co., 41 No. Front St.  
Roach, P, 35 N. Front St; waste.  
Robinson, P. J, 2034 Ella St; waste.  
Schmidt, Henry, 27 No. Front St.  
Simon's, Benjamin Sons, 1005 Canal St.  
Smith, Bradford, & Bro., 111 Chestnut St.  
Souder, H, 132 Chestnut St; broker.  
Southern Waste Works, 16th and Car-  
penter Sts; waste.  
Stern, Jacob & Sons, 3rd St. above Cal-  
lowhill; pullers.  
Stone & Christie, 48 S. Front St.  
Sutcliffe & Co, 22 Letitia St.  
Swift & Co., 100 Chestnut St.  
Sykes, David, 2080 E. Dauphin St; waste.  
Tattersfield & Co, 32 Letitia St.  
Tilden, W. T, 254 N. Front St.  
Tolland & Hanna, 109 So. Water St.  
Wallace, John H, & Bro, 1620 Lombard St;  
shoddy.  
Wallworth & Sons, 221 Chestnut St.  
Webb, Chas. J. & Co., 116 Chestnut St.  
Williey, Francis, & Co.; see Boston.  
Willey, J. H, 139 N. Water St; importer.  
Wilson, Thomas, 105 N. Front St.  
Wood Bros. & Co, 27 N. Front St.  
Woolston & Moore, 104 Chestnut St.  
Wright, W. L., 4129 Germantown Ave.;  
also waste and shoddy.

**Portland, Oregon.**

Allen & Lewis.  
Bernheim, Theo.  
Bissinger & Co.; see San Francisco.  
Kahn, Bros.  
Metzger, H.  
Pope, Anderson & Co.  
Russell, J. M. & Co

**Providence.**

Blanding, C. L. Mfg. Co, 26 Exchange  
Place; waste, etc.  
Brown, S. R, 16 S. Water St.  
Campbell, James, 84 Westminster St;  
also wool waste.  
Coffin & Dodd, 12 Exchange Place; bro-  
kers.

Farnum, Jerome B., 139 Canal St.; also waste.  
 Peck, Asa & Co, corner Atwell St. and Harris Ave; also waste and noils.  
 Pierce, Chas. F., 33 Canal St; shoddy and waste.  
 Slade, Walter F, & Co, 75 Exchange Place.  
 Smith, Albert W., 24 Davis St.  
 Smith, Albert W. & Co.; see Boston, Mass.  
 Smith, E. H., 84 Westminster St; broker.  
 Sweet, Walter B., 169 Canal St.; dealer.  
 Thornley, Richard, 17 Exchange Place; also waste.

---

### San Antonio.

Cohen, A. & Co.  
 Efron & Co.  
 Half, M. & Bro.  
 Hugo & Schmeltzer Co.  
 Zanderson, T. H.

---

### San Francisco.

Abbott, Chas. H, Bluxome cor Fifth Sts.  
 Abbott, Geo., 412 Townsend St.; broker.  
 Allen, Henry F., 202 California St.  
 Ballard & Hall, Bluxome and Fifth Sts.  
 Bissinger & Co, 215 Clay St.  
 Bloom, Samuel & Sons, 344 Clay St; pul-  
 lers.  
 Breslauer, L. & Co, 49 Bluxome St.  
 Catton, Bell & Co, 436 Townsend St.  
 Christy & Wise, 212 Sansome St.  
 Costigan, Cohen & Co, 203 Battery St.  
 Delleplane & Co., 425 Battery St.  
 Denigan, Thos. Son & Co, 132 Market St.  
 Goldtree Bros, 14 Sansome St.  
 Grangers' Business Assn, 108 Davls St.  
 Harris, I. & Co, 410 Townsend St.  
 Hulme and Hart, 10 Davis St.  
 Koshland, S. & Co, 222 California St.  
 Lee, H. H., 410 Townsend St.  
 Legallet-Hellwig Tanning Co, S. San Francisco St.  
 Levy, Isaac, 519 Clay St.  
 Moody, F. S., 422 Townsend St.  
 Moore, Ferguson & Co, 310 California St.  
 Moses, Charles S. & Co., Fifth and Blux-  
 ome Sts.  
 Norton Tanning Co, 312 Clay St.  
 Rosenberg's, Jacob, Sons, 221 Front St.  
 San Francisco Wool Sorting and Scour-  
 ing Co.  
 Sawyer Tanning Co., 312 Clay St.; also  
 Napa, Cal.  
 Schlesinger, A. C, 203 Battery St.  
 Shilling, Levi, 821 O'Farrell St.  
 Shoobert-Beale Co, 418 California St.  
 Simon and Manasse, 17 Battery St.  
 Sumner, W. E. & Co, 415 Front St.  
 Tyron, E. H., 412 Townsend St.  
 Watson & Marx, 134 Bluxome St.  
 Whitney & Webster, Townsend & Fifth  
 Sts.  
 Wollner, Jacob, Fifth and Bluxome Sts.

---

### St. Louis.

Allen, C. F., 120 No. Main St.  
 Boland & Ferguson, 406 No. Main St.  
 Byrne, Jos. & Co, 15 Commercial St.

Coffin & Dodd, 100 Main St.  
 Crowdus, J. C, 100 N. Main St.  
 Donzelot, Eugene, & Son, 16 So. Main St  
 Evans, Samuel, 12 S. Main St.  
 Frank, A. & Co, 210 S. Main St.  
 Funster Bros. & Co., 109 S. Main St.  
 Goldsmith, Daniel, 13 N. Main St.  
 Hannegan, Daniel, Prairie Ave.  
 Harris, B. & Co, 100 N. Second St.  
 Helledall, G, 107 Elm St.  
 Hellman, Godlove Mercantile Co, 120 N.  
 Main St.  
 Howard, J. H., 7 Cotton Exchange Bldg.  
 Jager, W. C., 116 No. Main St.  
 Johnston, James, 2 S. Main St.  
 Johnston, H. W, s. w. cor. Main and  
 Olive Sts.  
 Kahn, Herman & Co, 114 N. Commer-  
 cial St.  
 Landau, A., & Co., 720 No. Main St.  
 Marx, Henry & Co, 208 N. Main St.  
 McCullough & Tumbach.  
 McKenna Bros, 14 S. Main St.  
 Morse-Spurr Wool Scouring Co.  
 Sachs, I. & S, 100 N. Main St.  
 Schott, A. & Co., 111 S. Main St.  
 Spohr, Emil, 108 N. Main St.  
 Summerfield, M. & Co., 218 N. Main St.  
 Taylor, F. C. & Co, 208 N. Main St.  
 Warner & Co, W. F, 116 N. Main St.  
 Wolfheim, M., 927 N. 4th St.  
 Zelle Bros, 702 N. Third St.

---

### Springfield, Mass.

Mayo, A. N. & Co., 156 Lyman St.; waste;  
 see also cotton.

---

### Syracuse.

Avery, S. E.  
 Kingsley, E.  
 Marshall, Jacob, & Son.

---

### Troy.

Clexton, T. A, 529 River St.  
 Rankin, Wm., Tibbets Ave.  
 United Waste Mfg. Co., 145 River St.;  
 cotton, wool and merino shoddies and  
 wholesale dealers in wastes.

---

### Utica.

Hall, Benj. 263 Bleecker St.  
 Lowery, John A, 27 Hotel St.

---

### Wheeling, W. V.

Horkheimer Bros., 17 Main and 1416 South  
 Sts.

---

### Worcester, Mass.

Hull, Samuel E., 112 Front St.; also  
 waste.  
 Kilton, W. S. Co.

---

## Mills For Sale!

Woolen Mills and other manufacturing plants. • Agent for Sale of Mill Properties.

**R. B. DENNY,** 143 Federal St.,  
 Boston, Mass.

**COTTON DEALERS.****Amsterdam, N. Y.**

Charles, William B.

**Atlanta, Ga.**

Cay, Parrott & Co.  
 Ehney, E. S. & Co.  
 Harrington, W. H.  
 Maddox-Rucker Banking Co.; buyers.  
 Rioedan, John & Co.; factors.  
 Sanders, Swann & Co.; buyers.  
 Smith, H. H.

**Augusta, Ga.**

Alexander & Alexander; factors.  
 Baker & Smith; factors.  
 Cochran, C. & Co.; buyers.  
 Davison & Fargo; factors.  
 Doughty, J. J. & Co; buyers.  
 Doughty, L. G. & Co; buyer.  
 Fleming, E. C; factor.  
 Garrett & Latimer; factors.  
 Georgia Compress Co.  
 Howard, C. H. & Co.  
 Hull, Asbury; factor.  
 Inman & Co; buyers.  
 Lesser, S.; factor and cotton picker.  
 Mikell, W. E.; buyer.  
 Nixon & Danforth; factor.  
 O'Dowd, M. Sons & Co; factors.  
 Phinizy & Co; factors.  
 Pope & Fleming; factors.  
 Sloan, J. H.; buyer; also Wilmington,  
 N. C.  
 Speers & Pilcher. factors.  
 Tobin, P. B., Cotton Co.; exporters.  
 Union Compress Co.  
 Walker & Walker; buyers.  
 Whitney, S. M; factor.

**Baltimore.**

Baer, Lewis & Co., 206 Light St.; also  
 Norfolk and Newport News, Va.  
 Elliott Bros, 21 S. Gay St.  
 Messersmith, John K. & Co, 22 S. Gay St.  
 Ober, Albert G, 415 Water St.  
 Turnbull & Norris, 6 S. Gay St.

**Birmingham, Ala.**

Birmingham Compress Co.  
 Brown, W. S; factor.  
 Drennen & Co; factor.  
 Earle, Terrell & Co.; factors.  
 Hood, Yielding & Co.; factors.  
 Johnson, Nesbitt & Co; buyers.  
 Schwab-Jonas Co. (Inc.); buyers.  
 Smith & Coughlan; buyers; also Decatur,  
 Ala.  
 Teague, S. F.  
 Vandergrift, A. B; factor.

**Boston.**

Adams Bros, 571 Atlantic Ave; also waste.  
 Almy, Rogerson & Bremer, 95 Water St.;  
 brokers and buyers.  
 Amory, Ingersoll & Co., 95 Milk St.  
 Amory, R. G., 4 P. O. Square; broker.  
 Anderson, S. M., 115 Water St.; broker.  
 Andres, Fr. Jac. (Imp.), John Hancock  
 Bldg; broker.  
 Atkinson, C. F., 70 Kilby St; broker.  
 Barry, Thayer & Co, 60 Congress St.  
 Beebe, Lucius & Co, 89 State St.  
 Brown, Arthur E, 71 Kilby St; broker.  
 Brown, A. D. & Son, 35 Congress St; bro-  
 kers.  
 Bryant, H. P., 933 Exchange Bldg; bro-  
 ker.  
 Bush, S. D. & Co., 71 Kilby St.; brokers.  
 Coolidge, F. I., 112 Water St; broker.  
 Cummings, F. A. 112 Water St; broker.  
 Dickson, B. H. & Co, 71 Kilby St; broker.  
 Dodd, H. S., 89 State St.  
 Dorr, E. L. & Co, 701 Exchange Bldg;  
 broker.  
 Emerson, A. & Co., 683 Atlantic Ave.;  
 waste.  
 Emmons, Geo. B. & Co, 89 State St; bro-  
 kers.  
 Gibson, C. H, 27 Kilby St; broker.  
 Hartshorn, E. H, 85 State St; broker.  
 Houghton & Co, 70 Kilby St; broker.  
 Hill & Cutler, 567 Atlantic Ave; also  
 waste.  
 Howel Cotton Co., 531 Exchange Bldg;  
 brokers.  
 Jackson, P. T. & Co, 840 Exchange Bldg;  
 brokers.  
 Lougee, Geo. F. & Co., 112 Water St.;  
 brokers.  
 Nourse, Dabney & Co, 39 State St; bro-  
 ker.  
 Purdy, O. N. & Co., 290 Summer St.  
 Reis & Co., 620 Atlantic Ave.; Richard J.  
 Mayer, Mgr.; dealers; also cotton  
 waste and liners.  
 Remick, T. & Co., 489 Atlantic Ave.  
 Riley, C. E. & Co., 281 Congress St.  
 Shaw, E. A. & Co, 70 Kilby St; broker.  
 Sloan, N. P. & Co., 85 State St.; broker.  
 Stanwood, F. C., 4 P. O. Square; broker.  
 Storow, Chas. & Co, 602 Exchange Bldg;  
 brokers;  
 Stoddard, Haserick, Richards & Co, 152  
 Congress St; Egyptian.  
 Thatcher, T. C. & Co., 16 Pearl St.; also  
 cotton.  
 Union Carpet Lining Co, 179 Devonshire  
 St; waste.  
 Weld, Stephen M, & Co, 89 State St.  
 Wolf, W. & Sons (Germany), 620 Atlantic  
 Ave; foreign and waste.

**Blackshear, Ga.**

Brandy, The A. P. Co.; Sea Island.

**Charleston, S. C.**

Adams Cotton Co.; exporters.  
 Colcock, Thos. H.; buyer.

**The A. P. BRANTLEY COMPANY,**  
**Ginners of and Dealers in SEA ISLAND COTTON.**

We buy direct from farmers and interior merchants and can deliver to  
 manufacturers at a saving of profits and expenses of middlemen. We  
 number among our customers nearly every FINE mill in the U. S. A.

Connor, J. T.; factors.  
 Dill-Ball Co.; factors.  
 Frost, E. H. & Co.; factors.  
 Frost, Henry W. & Co.; buyer.  
 Gastaver, A. & Co.; buyers.  
 Goldsmith, A. A.; buyer.  
 Hall, W. P. & Co.; buyers.  
 Hesse & Shingler; factors.  
 Hanckel, F. S.; buyer.  
 Jervey & Bacot; factors.  
 Knoop, Frerichs & Co.; also New York City.  
 Lesesne & Wells; buyers.  
 Lucas, T. G. C.; buyer and broker.  
 Middleton & Ravenel; buyers and factors.  
 Pinckney, B. G. & Co.; factors.  
 Ravenel & Co.; factors.  
 Selgnious, J. M.; factors.  
 Silox & Co.; factors.  
 Simons, S. Wragg; buyer.  
 Smith, A. S. & Son; factors.  
 Smith, McIver & Co., T. P.; factors.  
 Smyth & Adyer; factors.  
 Taft, A. R. & Co.; buyers.  
 Wagener, F. W. & Co.; factors.  
 Whaley & Rlvers; factors.

### Chicopee, Mass.

Blaisdell, The S. Jr. Co.  
 Olmsted & Tuttle Co.; cotton waste.

### Cincinnati.

Taylor & Bro. 12<sup>th</sup> W. Second St.  
 Warren, A. H., 120 E. Canal St.

### Decatur, Ala.

Decatur Cotton Compress Co.  
 Falk, L. M.

### Demopolis, Ala.

Develin, C. C.  
 Loveman, A. P. & Co.; also Tuscaloosa.  
 Maury, Z.; buyer.  
 Stickney, F. G.

### Eufaula, Ala.

Edmonson & Bro.  
 Gulce Bros.  
 Shorter, E. S.; factor.  
 Tullis, J. W. & Co.

### Eutaw, Ala.

Planters' Warehouse & Commlsion Co.  
 Ward, W. R.

### Fall River, Mass.

Aldrich & Hawkins; brokers.  
 Almy, Rogerson & Bremer, 108 Bedford St.; buyers and brokers.  
 Andrews & Horton.  
 Blaisdell, Wm. & Co.  
 Borden, Andrew & Son.  
 Brow, E. H. B. & Co.  
 Carr, C. H.  
 Durfee & Lown; brokers.  
 Everett, N. B. & Co; brokers.  
 Hawes, G. H.  
 Hooper & Buffington.  
 Haughwout, V. W.  
 Lewis, N. & N. R.; cotton waste.  
 Massasoit Mfg. Co.; cotton waste; also New York City.  
 McFadden, Geo. & Bro. (See Phila.)  
 Rhodes, Geo. H. & Co.; brokers; also New Bedford and New York City.  
 Westport Mfg. Co.; dealers in cotton waste.

### Galveston, Tex.

Bornefeld, A. & Co.; dealers.  
 Bornefeld, Robert; buyer.  
 Dobson, Geo. B. & Co.; buyers.  
 Focke, Wilkins & Lange.  
 Foinquinos & Steinhauser; buyers.  
 Hiles, Wilson & Co.; buyers.  
 Kauffmann & Runge.  
 Kempner, H. (Estate).  
 Ladd & Co.; buyers  
 Lammers & Flint; factors.  
 Mayhoff, Gus; buyer.  
 Milroy & Co.; buyers.  
 Moody, W. L. & Co.; factors.  
 Mueller & Co.; buyers.  
 Orthwein-Flitzhugh Cotton Co.  
 Paul, P. G.; buyer and classer.  
 Rogers, John D. & Co.; factors.  
 Skinner, J. D. & Son; factors.  
 Stewart-France-Hamurst Co.; buyers.  
 Stewart, T. W. & Co.; buyers.  
 Sweeney, E. & Co.; buyers.  
 Taylor, Thomas & Co.; buyers.  
 Townsend, Cowie & Co.; see New Orleans, La.  
 Willis, P. J. & Bro. (Inc.); factors.  
 Wood, Jas. T. & Cousin.

### Greenville, Miss.

Balrd-Smith Co. (Inc.)  
 Blum, Abe; cotton factor and commision.  
 Craig, W. C. & Co.; also Vicksburg.  
 Fisher, J. H.  
 Hall, C. E. F. & Co.; see Memphis, Tenn.  
 Hawkins, Crittenden & Co.; also Sunny-side, Ark.  
 Holland, E. & Co.  
 Ireys, H. T. & Co.  
 Kline, Wilson & Co.; also Yazoo City.  
 Metcalf, F. & Co.; factors.  
 Starling, Lyne & Co.  
 Waldauer Co. (Inc.)  
 Wilzin Cotton Co. (Inc.)

### Grenada, Miss.

Grenada Cotton Co.; buyers.  
 Newburger Cotton Co.  
 Shingleur, Johnston Co.; also Jackson.

### Jackson, Miss.

Hart, J. & B.  
 Hayne & Co.  
 Jones Bros. & Co.; buyers.  
 Shingleur-Johnston Co. (Inc.); also Grenada.  
 Virden, E. & S.; buyers.

### Indian Orchard, Mass.

Indian Orchard Co.

### Little Rock, Ark.

Bennett, Z. & Co.; buyers.  
 Huger, D. E. & Co.; buyers.  
 Jones, T. F. Co.  
 Lesser Cotton Co.; also St. Louis.  
 Little, R. A. & Co.; factors.  
 Miller, Geo. M. & Co.; buyers.  
 Morris, R. E. & Co.; buyers.  
 Srygley, L. A.; broker.

### Louisville.

McCord & Wright, 505 W. Main St.  
 Trabue & Barksdale, 154 Fourth St.

**Macon, Ga.**

Adams, B. T. & Co.; factors.  
 Davis, W. A. & Co.; cotton factors.  
 Dove, E. R. D. & Co.; buyers.  
 English, Johnston & Co.; factors.  
 Ford, B. B. & Co.; buyers.  
 Head, J. D.; warehouse.  
 Heard Bros.; factors.  
 Jones, B. L.; factory.  
 Moore & Holmes; factors.  
 Sanders, Swan & Co.; buyers.  
 Snowden, W. H. & Co.; buyers.  
 Willingham, C. B.; factors.

**Memphis, Tenn.**

Abston, W. J. & Co, 284 Front St.  
 Ackerman & Co., 10 W. Court St.  
 Ahbuckle, W. S. & Co., 258 Front St  
 Armistead Bros, 282 Front St  
 Armistead, Chapman & Co, 276 Front St.  
 Armour Cotton Co, 196 Adams St.  
 Arnold, Geo. Co, 260-262 Front St.  
 Ball, W. M. & Co, 276 Front St.  
 Barksdale, Denton & Co, 266 Front St.  
 Beecher, B. B. & Co, 43 1/2 Madison St.  
 Bond Cotton Co, 201 Madison St.  
 Bowdrie Bros. & Co., 272 Front St.  
 Bowles, Wm. & Sons, 280 Front St.  
 Boyd, Irby & Co., 352 Front St.  
 Brooks, Neely & Co, 367 Front St.  
 Brower, Wm. & Son.  
 Brown & Perkins, 266 Front St.  
 Coate Bros, 280 Front St.  
 Cocke, J. L. & Co, 349 Front St.  
 Cowan, C. C. & Co, 316 Front St.  
 Crisman, C. H. & Co., 252 Front St.  
 Crump, F. M. & Co, 308 Front St.  
 Currier & Warrick.  
 Delta Cotton Co, 8 1/2 Madison St.  
 Dillard & Coffin Co, 306 Front St.  
 Dockery & Donelson, 320 Front St.  
 Douglass Bros, 354 Front St.  
 Estes, Z. N. & Co, 11 Union St.  
 Falls, J. G. & Co., 250 Front St.  
 Falls Cotton Co., 276 Front St.  
 Fargason, J. T. & Co, 369 Front St.  
 Farnsworth, C. F. & Co, 306 Front St.  
 Frank, Godfrey & Co, 15 Union St.  
 Frolich, Wm. & Co, 266 Front St.  
 Fulmer & Co, 348 Front St.  
 Gage & Hunter, 275 Webster Ave.  
 Gage, W. A. & Co, 300 Front St.  
 Gatens, P. & Son, 266 Front St.  
 Gates, Wm. B.  
 Gavin, M. & Co, 232-234 Front St.  
 Goodlett & Co, 282 Front St.  
 Goodman, Walter & Co.  
 Graves & Vinton Cotton Co, Odd Fellows Bldg.  
 Gunther, M. H. & Co, 364 Front St.  
 Hale, B. W. & Co, 316 Front St.  
 Hall, C. E. F. & Co., 314 Front St.; also Greenville, Miss.  
 Harvey, B. B. & Co.; also Harvey, Black & Co., Oakland, Mass.  
 Hawkins, D. M. & Co, 264 Front St.  
 Hayden & Co, 225 Main St.  
 Hill, Fontaine & Co, 296 Front St.  
 Hughes & Mercer, 224 Front St.  
 Humphreys & Clark.  
 Jacobs & Hexter, 274 Front St.  
 James, The J. M. Co, 230 Front St.  
 Jones & McNamee, 252 Front St.  
 Lake, L. S., 268 Front St.  
 Lundee, S. & Co, 334 Front St.  
 McGrath, John & Co, 304 Front St.  
 McNeas, A. R. & Co.  
 Mallory, W. B. & Sons Co., 380 Front St.  
 Mathis, Reeder & Co.  
 Morgan & Scott, 286 Front St.  
 Mississippi Valley Cotton Co, 260 Front St.  
 Newburger Cotton Co, 349 Front St.

Patton, A. A. & Co, 31 Cotton Exchange Bldg.  
 Polk, Spinning & Co, 268 Front St.  
 Pope, J. H. & Co, 254 Front St.  
 Porter, Deming & Co, 356 Front St.  
 Post, J. A. & Co, 266 Front St.  
 Pritchett, McCormack & Co, 9 Union St.  
 Rankin & Wild, 304 Front St.  
 Reed, W. G, Front St.  
 Sledge & Norfleet Co., 372-374 Front St.  
 Smith, Cleland K. & Co, 361 Front St.  
 Smith, Dennis & Co, 282 Front St.  
 Sternberger, Felsenthal & Co, 318 Front St.  
 Stewart, Gwynne & Co, 356-358 Front St.  
 Tate Bros, 336 Front St.  
 Taylor, W. F. & Co, 314 Front St.  
 Townsend, Cowie & Co, 282 Front St.  
 Treadwell, A. B. & Co, 376 Front St.  
 Walsh, J. T. & Bro, 82 Main St.  
 Wardle, Arthur & Co.; buyers.  
 Watson, Wood & Co.  
 Wilkinson Bros, 360 Front St.  
 Williams, Evander & Co, 264 Front St.  
 Wilson & Ward Co, 4 W. Court St.  
 Withers, W. H. & Co, 366 Front St.  
 Woolfenden, Robert & Co., 308 Front St.; also New Orleans.  
 Wright, Oliver & Co.  
 Wynne, Love & Co, 366 Front St.

**Mobile, Ala.**

Armor Commission Co; factors.  
 Brown Bros; factors.  
 Burgess, D. R. & Co.; factors.  
 Bush, J. C. & Co; factors.  
 Dorgan, L. C. & Co; factors, buyers.  
 Dumas, Watters & Co; factors.  
 Fitzpatrick, B. F. & Co; factors.  
 Haas, S & Co; factors.  
 Hearin, W. J. & Co; factors.  
 Holzborn, Ernest & Co; buyers.  
 Huger, D. E. & Co.; buyers; also Little Rock, Ark.  
 Irwin, T. K.; broker.  
 Jones, Winston & Co; factors.  
 Kahn, B. & Co; factors.  
 Lewin, Robt. & Co; buyers.  
 McCarty, A. F. & Co.; buyers.  
 Pope, R. P. & Co; buyers.  
 Rhett, Benj. & Co; buyers.  
 Robins, Fry & Co; factors.  
 Ross Bros. & Co; factors.  
 Touart, L; factor.  
 Wheeler, C. J. & Co; buyers.

**Montgomery, Ala.**

Cary, W. A. & Co.; buyers.  
 Clisby, J. H. & Co.  
 Fisk, W. B. & Co.  
 Johnson & Hammond; buyers.  
 Lehman Durr Co.; commission.  
 Montgomery Ginning & Cotton Co  
 O'Conner, J. P. & Co.; buyers.  
 Sellers, Onnu; buwer.  
 Siebs, J. G. & Co.; buyers.  
 Thompson, M. I. R. & Co.; buyers.  
 Union Warehouse Co.; factors.

**New Bedford, Mass.**

Almy, Rogerson & Bremer, 108 Union St.; buyers and brokers.  
 Headley, P. C. Jr; broker.  
 Rhodes, Geo. H. & Co.; also Fall River, Mass. and New York City.

**New Orleans.**

Abraham, Hy. & Son, 216 Baronne St; factor.  
 Airey, T. L. & Co, 818 Union St; factor.  
 Allgeyer, E. & Co, 924 Gravier St; buyer.  
 Atkinson, Wm., 324 Gravier St.; factor.

- Bachelor, Wm. H. & Co. (Ltd.)  
 Beer, H. & B, 325 Baronne St; future brokers; F. O. B. Sellers.  
 Braun & Glazebrook, 316 Baronne St.; buyers.  
 Brittin, A. & Co; Hennen Bldg; future broker.  
 Briarly, William & Co.; buyers.  
 Brown, W. P. & Co., 839 Gravier St.; F. O. B.  
 Cau, Jo, 839 Gravier St.; buyer.  
 Charnock, Henry, 629 Gravier St.; buyers.  
 Christ, L.; broker.  
 Clason, A. & Co, 827 Union St; buyers.  
 Coate Bros., 817 Union St.; buyers; also Memphis, Tenn.  
 Couturie, F., 839 Gravier St.; buyer.  
 Cornille, O, 814 Gravier St; buyers.  
 Corral & Sevilla, 219 Varieties Alley; buyers.  
 Craig, W. C. & Co.; also Vicksburg, Miss.  
 De Buys & Labouisse, 836 Common St; future brokers & F. O. B. Sellers.  
 Dessomes, H, 833 Union St; buyer.  
 Dixey, R. H. & Co.; buyers.  
 Dixon, Jos. M., 325 Baronne St.; buyer.  
 Dreuil, E. & Co.; buyers.  
 Eltzen, E., 938 Gravier St.; F. O. B. Seller.  
 Ellis, C. P. & Co, Cotton Exchange Bldg; future broker.  
 Esteve, L. & Co.; exporters.  
 Evans, Geo. S, 826 Union St; buyer.  
 Fairchild & Hobson, 209 Varieties Alley; future brokers.  
 Fornaris, S. V. & Co.; buyers.  
 Frankenhush, J. M. & Sons, 806 Perdido St; factors.  
 Frederic, H. A, 814 Gravier St; broker.  
 Gassner & Co, 836 Common St; buyers.  
 Gilbert & Clay, Cotton Exchange Bldg.; future brokers.  
 Glenn, I. E. & Co, Cotton Exchange Bldg; future broker.  
 Goodman, A. C. & Co.; brokers.  
 Gragard, Geo. R. Co. (Ltd.), 832 Union St.; factor.  
 Gumbel, Ferdinand & Co., 812 Perdido St.; factors.  
 Gumbel, S. & Co.; 824 Gravier St.; factors.  
 Hanemann, A. H. & Co.; brokers.  
 Hannay & Lawson, 836 Common St.; future brokers.  
 Hanson, C, 817 Perdido St; broker.  
 Hardie, J. S. Sons & Co, 843 Union St; factors.  
 Hardie's, John T. Sons & Co.  
 Hardie, W. T. & Co., 938 Gravier St.; factors.  
 Harris, Day & Co.; factors.  
 Hellwege, Peter & Co., Cotton Exchange Bldg; future brokers.  
 Hohagen & Co.; buyers.  
 Hoford, Minoprio & Co, 843 Union St; buyers.  
 Hume, Wm. J. & Co.; buyers and exporters.  
 Hyman, Hiller & Co.; factors.  
 Knoop, Frerichs & Co.; buyers; also New York.  
 Lehman, Stern & Co. (Ltd.), 839 Gravier St; future brokers, F. O. B. Sellers.  
 Levy, M. & Sons; factors.  
 Lichtenstein, H. & Son; factors.  
 Lionnet, A., Cotton Exchange Bldg.; buyer.  
 Lippmann, L.; commission.  
 Lucy, Harold P. & Co.; buyers.  
 Ludlow, H. C, 817 Union St; buyer.  
 Majors, T. J. & Co., Cotton Exchange Bldg.; buyers.  
 Martin, E. & Co., 318 Baronne St.; buyers; also Vicksburg, Miss.  
 Mather, Geo. & Co, 914 Gravier St; future brokers.  
 Mazerat, J, 914 Gravier St; broker.  
 McLean, James Lea & Co., 819 Gravier St.; future brokers.  
 Minge, C. H. & Co, 845 Union St; F. O. B. Seller; also Shreveport, La.  
 Moore, Lucas E. & Co, 820 Gravier St; buyers.  
 Nell, Henry M. & Co., 914 Gravier St.; buyers.  
 Newburger & Levy, 938 Gravier St; F. O. B. Seller.  
 Newman, H. & Co, 932 Gravier St; factors.  
 Norden, A. & Co., 839 Gravier St.; buyers; also New York.  
 Overbeck, E. & Co, 226 Carondelet St; buyers.  
 Parker, John M. & Co., 819 Perdido St.; factors.  
 Paton, A. A. & Co., 817 Union St.; buyers; also Memphis, Tenn., St. Louis, Mo., and Dallas, Texas.  
 Paton, Bell & Co., 817 Perdido St.; buyers; also St. Louis, Mo.  
 Payne, J. U. & Co., 303 Baronne St.; factors.  
 Peale, W. A. & Co, 838 Union St; factors.  
 Pferdmgenges, Preyer & Co, 309 Baronne St.; buyers; also Savannah, Ga.  
 Pinckard & Meyer, Cotton Exchange Bldg; future brokers.  
 Poutz, Pierre & Son, 421 Carondelet St.; buyers.  
 Puech & Tertrou, 839 Gravier St.; buyers.  
 Putnam & King, 926 Gravier St.  
 Rainey, James, 341 Carondelet St.; buyers.  
 Ralli Bros. Agency, 932 Gravier St.; buyers; also New York and Galveston, Texas.  
 Rawlins, S. W. & Son; factor.  
 Ruegg Commission Co., 819 Gravier St.; buyers.  
 Sanchez, A. P. & Co.  
 Schaefer, H. F. C. & Co, Cotton Exchange Bldg; future brokers.  
 Schreiber, A, 421 Carondelet St; buyer.  
 Sentell, G. W. & Co.; factors.  
 Seruntine, A, 829 Gravier St; broker.  
 Skerl, H. T.; buyer.  
 Skinner Bros, 924 Gravier St; F. O. B. Seller.  
 Sloan, H. W, 828 Perdido St; buyer.  
 Smith, Mason & Co., 839 Union St.;  
 Stahel, E. S. & Co.; buyers.  
 Steinhart & Co, 235 Baronne St; buyers.  
 Stewart Bros. & Co, 836 Union St.  
 Stucken, Aug. & Co; 818 Union St; buyers.  
 Thomas, S. O. & Co.; factors.  
 Thompson, W. B. & Co.; factors.  
 Townsend, Cowie & Co, 832 Common St; buyers, also Memphis, Tenn.  
 Vincent & Hayne, 924 Gravier St; buyers; also Vicksburg, Miss.  
 Violet, Edwin R., 824 Common St.; future broker.  
 Von Meysenburg, E., 824 Union St.; buyer.  
 Warren & Co.; buyers.  
 Walmsley, S. P, 812 Perdido St.  
 Weis, J. & Co.; factors.  
 Wernicke & Co, 226 Carondelet St; buyers and exporters.  
 Wilkie, John & Co, 200 Baronne St; buyers, also Memphis, Tenn.  
 Williams, J. Herbert, 829 Perdido St.; buyers.  
 Wood, James T. & Cousin, 932 Gravier St.; buyers.  
 Woolfenden, Robert & Co., 814 Gravier St.; buyers; also Memphis, Tenn., and Galveston, Texas.  
 Ziegler, W. H. & Co, 938 Gravier St; buyers.

## New York.

American Trading Co., 70 Broad St.; also San Francisco, Cal.  
 American Cotton Co., 70 Broad St.  
 Andreas & Co., 16 Exchange Place. change; export.  
 Arbib, E. J. & Co, 53 East 9th St.  
 Bache, J. S. & Co, 66 Exchange Place; brokers.  
 Baily & Montgomery, 61 Cotton Exchange.  
 Bateson, Hooper & Co., 23 Cotton Exchange.  
 Benner, N. A. & Co, 19 Old Slip.  
 Birdseye & McCormick, 105 Hudson St.  
 Black, John F., 39 Exchange Bldg; broker.  
 Bloss, J. O. & Co, 44 Wall St.  
 Botassi, D. N., 35 S. William St; broker.  
 Boyan, Julius A., 136 Pearl St.; broker.  
 Brady, Thos. H., 216 Church St; broker.  
 Braun & Lansing, 87 Pearl St.  
 Brennecke, Geo. & Co, Cotton Exchange Bldg; broker.  
 Bullard & Wheeler, 84 Beaver St.  
 Callender, Holden & Co, 77 Cotton Exchange; export.  
 Capelle, Herman & Co., 60-87 Front St.  
 Chapman, Selter & Allen, 26 Cotton Exchange Bldg; broker.  
 Clewes, Henry & Co, 99 Franklin & 15 Broad Sts; broker.  
 Coates, H. T. & Co., 41 Cotton Exchange St; broker.  
 Cone, Ed. K., 70 Cotton Exchange.  
 Copeland, Geo. & Co, 129 Pearl St; broker.  
 Cummings, Geo. W., 128 Pearl St; broker.  
 Davidson, Benj., 141 Pearl.  
 Dayton & Waldo, 28 Cotton Exchange; broker.  
 De Gumoens, Louis & Son, 55 Cotton Exchange Bldg; broker.  
 Eccles, A. J., 65 Cotton Exchange.  
 Elinger & Abrahams, Williams St.  
 Fachrl, F. & Co, 56 Beaver St; broker;  
 Federman, Louis.  
 Feener & Thomas, 128 Pearl St.  
 Fletcher & Hotze, 13 William St.; also Little Rock, Ark.  
 Garrison, John H., 8 Old Slip; brokers. kers; also Cincinnati, Ohio.  
 Goodhart, P. J. & Co, 38 Wall St; brokers; also Cincinnati, O.  
 Grace, W. R. & Co, 1 Hanover Square.  
 Graham, J. C. & Co., 42 Cotton Exchange Bldg; broker.  
 Grant, Geo. M., 18 Cotton Exchange.  
 Greene Bros., 130 Pearl St.  
 Greene, T. T. & Son, 8 Old Slip.  
 Gruner, R. S., 41 Cotton Exchange.  
 Gruner, S. & Co, 13 William St.  
 Guest, F. B., 11 William St; broker.  
 Gwathmey & Co, 49 Cotton Exchange.  
 Hagedorn, Herman, 6 Cotton Exchange.  
 Hawley, F. B., 141 Pearl St.  
 Hentz, H. & Co, 22 William St.  
 Hochstaetter, Wm. J., Cotton Exchange.  
 Hoffman Mfg. Co., 78 Duane St.  
 Hooper, R. H. & Co., 23 Cotton Exchange.  
 Hopkins, Dwight & Co, 52 Cotton Exchange.  
 Howard, Edward, 154 W. Broadway; waste.  
 Hubbard Bros. & Co., 66 Beaver.  
 Inman, Swann & Co., 11 Cotton Exchange.  
 Johnston, Robert J. & Co., 74 Cotton Exchange.  
 Jones, Eure & Co., 126 Pearl St.; broker; also Eure, Gregory & Co., Norfolk, Va.  
 Knoop, Frerichs & Co, 33 Cotton Exchange.  
 Kremelberg & Co., 160 Pearl St.; also Louisville, Ky.  
 Latham, Alexander & Co, 18 Wall St.  
 Lathrop & Smith, 37 Broad St.  
 Lecount, H. M. & Co., Cotton Exchange.  
 Lee, C. W., Coffee Exchange.  
 Lehman Bros, 22 William St.

Levy, M. P., 516 Coffee Exchange.  
 Magnus, Otto, 23 Cotton Exchange.  
 Mandell, K. & Co, 24 Howard St.  
 March, John P. & Son, 91 Water St.  
 Martin, H. A., 136 Pearl St.  
 Maury, Jos. F., 79 Cotton Exchange.  
 McDougall, Robert P, 35 Cotton Exchange Bldg; broker.  
 McFadden, Geo. H. & Bros., Cotton Exchange.  
 McIntyre & Wardwell, Produce Exchange; dealers.  
 Messick, Chas, 92 Cotton Exchange Bldg; broker.  
 Miller, Walter T. & Co., 29 Cotton Exchange Bldg; broker.  
 Minzesheimer, Chas. & Co, 7 Wall St.  
 Mohr, Hanemann & Co, 27 Cotton Exchange Bldg; broker.  
 Moore, Robert & Co, 56 Beaver St.  
 Munn, S. Son & Co, 66 Beaver St; broker.  
 Murchison & Co., 74 Wall St.  
 Murphy & McCormack, 135 Pearl St.  
 Murray, C. E. & Co, 42 Water St.  
 Noorden, A. & Co., 12 Cotton Exchange; exporters; also New Orleans, La., and Savannah, Ga.  
 Parker, J. H. & Co., 36 Cotton Exchange.  
 Parrott, Marcus J, 31 Cotton Exchange Bldg; broker.  
 Paterson, Downing & Co., 21 State St.  
 Pfann, Jerome J., Room 518 Wool Exchange; also waste.  
 Plm, Forwood & Kellogg, 22 State St.  
 Perkins, Dennis & Co, 125 Pearl St; broker.  
 Pope, C. H. & Co, 60 White St; broker.  
 Ranger, S., 69 Cotton Exchange.  
 Rhodes, Geo. H. & Co., 54 Stone St.; also New Bedford and Fall River, Mass.  
 Rich, Clayton E. & Co., 416 Coffee Exchange Bldg.; broker.  
 Robinson, T. M. & Co, 11 William St.  
 Rountree, R. H. & Co, 4 Cotton Exchange Bldg.  
 Royce & Co, 69 Cotton Exchange Bldg; broker.  
 Schiffer, L. G., 71 Cotton Exchange Bldg; broker.  
 Scott, Ed. J., 41 Cotton Exchange.  
 Shepperson, A. B., 38 Cotton Exchange.  
 Sledenburg, R. & Co, 75 Cotton Exchange Bldg; broker.  
 Sillicock, P. M., 3 Cotton Exchange.  
 Sondhelm Bros., 20 Cotton Exchange Bldg; broker.  
 Swanson, Grlerson & Co, 40 Cotton Exchange Bldg.  
 Talntor, Chas. B. & Co., 2 Stone St.  
 Tannor, James, 60 Cotton Exchange.  
 Tubbs, Wm. 70 Cotton Exchange Bldg; broker.  
 Tuthill, H. E., 28 Cotton Exchange.  
 Van Riper, F. & Co., 68 Cotton Exchange.  
 Violett, Atwood & Co, 30 Broad St; brokers.  
 Vohmann, C., 15 Whitehall St.  
 Wallace, T. E. & Co, 203 Broadway; importers and jobbers; also hair mass tow and fibers.  
 Wallace, Muller & Co, 48 Pearl St.  
 Weld & Neville; also Houston, Texas.  
 Weld, Stephen M. & Co, 18 Cotton Exchange Bldg.  
 Wenman, James F, 12 Old Slip; broker.  
 Wheeler, Wm. H., 84 Beaver St.  
 Wild, J. T., 128 Pearl St.  
 Wilson, R. T. & Co., 141 Pearl St.  
 Wilson, W. W., 24 Cotton Exchange.  
 Wisner, Wm. H., 45 Cotton Exchange.  
 Woodward & Stillman, 22 William St; dealers.  
 Ziegler, Merrifield & Co., 73 Cotton Exchange; dealers.

## Norwich, Ct.

Bliss, F. G.  
 Carroll, L. W. & Son, 17 Water St; brokers.

**Philadelphia.**

Brazer, Thurber T., 45 Strawberry St.  
 Borden & Schwab, 311 Walnut St.; buyers.  
 Brown, Jas. E. & Son, 100 Chestnut St.  
 Burr Bros, 115 S. Water St.  
 Clapp & Fowler Waste Co., 116 Produce Ave.  
 Connell, John J., 239 No. Front St.  
 Crompton, Thos., 247 No. Front St.  
 Dodgson, H., 135 S. Water St.  
 Dumee, Son & Co, 402 Provident Bldg.  
 Durkee, Alfred R. & Co., 149 So. Hancock St.  
 Hammer, Wm. G. & Co, 17 N. Front St.  
 Henry, Thos. & Son, 118 Arch St.  
 Hoffman, Cockran & Co., 415 Market St.  
 Hoffman, Geo. E, 248 Chestnut St.  
 Hongler & Bready, 105 N. Water St.  
 Hyde, Edward S., 223-225 Chestnut St.  
 Jennings, Edmond P., 208 Chestnut St.  
 Kay, John J., 132 Allen St.  
 McFadden, Geo. H. & Bros, 121 Chestnut St.  
 O'Neil, Chas, 57 N. Front St.  
 Sibley, F. P., 107 S. Second St.  
 Sloan, N. P. & Co., 241 Chestnut St.  
 Suplee, Chas. J., 215 Chestnut St.  
 Van Leer & Somers, 241 Chestnut St.  
 Widdall, Edmund & Son, 132 Chestnut St.  
 Wilson, Thomas, 105 N. Front St.

**Providence.**

Almy, Arthur C, Market Square.  
 Deming, R. H. & Co., 10 S. Water St.; also New Bedford, Mass.  
 Emerson, A. & Co., 33 Fountain Square; also Boston, Mass.; (also waste).  
 Hazard Cotton Co, 11 Market Square.  
 Remington, Daniel & Son, S. Water, cor. College St.  
 Reynolds, F. W Co, S. Water St; broker.  
 Rhodes, Jas. P. & Co, 5 College St; broker.  
 Richmond & Tiffany, 44 S. Water St.  
 Webster & Chaplin, 20 S. Market St; brokers.  
 Wilcox, L. Morton, & Co, 28 N. Main St; brokers; also Springfield, Mass.

**Savannah, Ga.**

Axson, R; factor.  
 Billington, Robert; export.  
 Butler, Stevens & Co.; factors.  
 Cutts, E. A.; broker.  
 Daffin, P. D. & Son; brokers and exporters.  
 Dancy, D. Y. & Chaplin; factors.  
 Dickinson, G. E; broker.  
 Duckworth & Co; buyers.  
 Dwelle & Dwelle; factors.  
 Ellis, Chas.  
 Esteve, Jos. M. & Co.; buyers.  
 Flannery, John & Co; factors.  
 Floyd & Co.; buyers.  
 Frost, H. W. & Co.; buyers; also Charleston, S. C.  
 Gaudry, Crisp & Co; factors.  
 Gordon, W. W. & Co; factors.  
 Greig & Jones; factors.  
 Holst, J. B. Co.; buyers; also Columbus, Ga.  
 Hunter, Pearce & Battice; buyers.  
 Hutton, H. M.; broker.  
 Jackson, A.; buyer.  
 Leffer, A. & Co.; factors.  
 Le Hardy & Co.; exporters.  
 Malloch, John & Co.; buyers.  
 McLean, Malcolm; factor.  
 Murphy & Co.  
 Norden, A. & Co; buyers.  
 Pferdmenges, Preyer & Co.; buyers; also New Orleans, La.  
 Saussy & Huxford; factors.

Shearson, C. A.; buyer, broker and exporter.  
 Stewart, J. T. & Son; brokers and exporters.  
 Strauss & Co.; buyers; also New Orleans, La. and Houston, Texas.  
 Sybrandt & Co; exporters.  
 Wilcox, Ives & Co; factors.  
 Willder & Co.; buyers and exporters.  
 Williams, J. P. & Co; factors.  
 Wood, J. S. & Bro; factors.  
 Woods & Malone; factors.  
 Young, L. G; buyer.

**Selma, Ala.**

Adler, J. C.; factor.  
 Agee, R. H. & W. C.; factors.  
 Babcock, John.  
 Bloch, I. & Co.  
 Gary & Kennedy; factors.  
 Hooper, C. W. & Co.; factors.  
 Howard, I. B. & Son.  
 Hubbard & Clay; factors.  
 Kahn, Nathan & Son; factors.  
 La Mar, L. & E.; factors.  
 McKinnon, C. A. & Co.  
 Parke & Field Cotton Co.; buyers.  
 Schwartz Commission Co.  
 Siegel, M.; commission.  
 Smith, M. S.; factor.  
 Sulzbacher, B.; factor.  
 Thompson, W. L. & Co.  
 Ward & Son; factors.  
 Welch, W. P. & Co.  
 Woolsey, Winthrope.

**Springfield, Mass.**

Mayo, A. N. & Co., 156 Lyman St.; waste; see also wool.

**St. Louis, Mo.**

Allen-West Commission Co., 104 S. Main St.; factors.  
 Birdseye & McCormick, Cotton Ex-buyers.  
 Hill, Napoleon, Cotton Co., 116 So. Main St.; factors.  
 Senter Com. Co., 27 S. 3d St.; factors.  
 Taylor, Geo., Com. Co., 300 S. Main St.; buyers.

**Utica, N. Y.**

Allison, G. F. & Co; also waste.  
 Lowery Bros.; also waste.

**Wilmington, N. C.**

Calder Bros.; commission.  
 Cooper, W. B.  
 Gore, D. L. & Co.  
 Hall & Pearsall.  
 Heyer, M. J.  
 McEachern, Duncan.  
 McNair, S. P.  
 McNair & Pearsall.  
 Murchison & Co.  
 Rankin, J. T.  
 Sloan, J. H.  
 Sprunt, Alexander & Son; exporters.  
 Williams Bros.  
 Worth Co., The.

**Yazoo City, Miss.**

Barnwell & Co.  
 Brown & Troy.  
 Compton, T. W. & Co.  
 Craig, T. H. & Co.  
 Gllruth, T. W.  
 Hollingsworth Bros.  
 Powell, J. F.  
 Yazoo Cotton Co.



# MANUFACTURERS' SELLING AGENTS

... AND ...

## Dry Goods Commission Houses,

IN THE PRINCIPAL CITIES OF THE UNITED STATES.

### Amsterdam.

Charles, William B.; cloth, commission;  
yarn and cotton.

### Baltimore.

Bowling, A. M., 201 W. Lombard St.;  
hosiery and underwear.

Campbell, Geo. S., 49 W. Biddle St.; cot-  
tons.

Carey, Bayne & Smith, 17 W. German  
St., (see New York).

Cassard, J. D., & Son, 64 Hopkins Place;  
(New York office, 69 Worth St.) (also  
St. Louis), cottons.

Danforth, Clark & Co., 5 Hanover St.;  
cotton.

Dickey, W. J. & Sons, 16 Light St. (New  
York office, 88 Leonard St.); cottons  
and woolens.

Douglas, Henry & Co., 31 S. Howard St.;  
hosiery.

Durbin, J. F., 16 Hanover St.; hosiery.

Farber, H. J., Brewry & Co., 15 Hopkins  
Pl.; cotton dress goods, etc.

Green, Amon & Co., 5 & 7 West German  
St.; yarns, bats, etc.

Grotjan, Lobe & Co., 210 West Baltimore  
St.; carpets.

Harding, Chas. H., 16 Hanover St.; hos-  
iery.

Hight, H. H., 1 Sharp St.; hosiery, etc.  
Hooper, Wm. E., & Sons, 28 S. Frederick  
St.; yarns.

Horner, Frank W., 121 Hanover St.; hos-  
iery and cotton goods.

Key, Edward L., 17 W. German St.;  
cotton.

Lewis, H. & W. H., National Bank Bldg.;  
(see New York.)

Oppenheim, A. J., Baltimore and Han-  
over Sts.; hosiery and cotton goods.

Phillips Bros & Co., 33 Hanover St.; cot-  
tons & woolens

Schulz & Bro., 215 West German St.  
yarn.

Simpson, Wm. Sons & Co., 10 Hopkins  
Place; prints. (see New York.)

Stewart, A. L., 203 W. Lombard St.; lin-  
ens and cottons.

Tapscott, John S. & Co., 100 Hopkins  
Place; hosiery.

Treat & Converse, 111 W. German St.;  
prints, woolens and cottons.

Witmer, E. F. & Co., 16 Hanover St.;  
woolens.

Woodward, Baldwin & Co., 9 Hanover  
St.; cottons and woolens. (see New  
York.)

### Boston.

Allen, Geo. F. & Co., 105 Summer St.; silk  
and cotton threads.

Allen, H. F., 35 Kingston St.; hosiery and  
knit goods.

Allen-Lane Co., The, 266 Devonshire St.;  
cassimeres, dress goods and blankets.

Almy, R. T. & Co., 602 Washington St.;  
clothing.

American Cotton Yarn Exchange, 67  
Chauncy St.; Arnold B. Sanford,  
pres.

American Thread Co., 112 Beach St.;  
threads.

American Woolen Co., 116 Ames Bldg.

Amory, Browne & Co., 48 Franklin St.;  
sheetings, domet and canton flannels,  
blankets, ginghams and cotton dress  
goods.

Appleton, R. M., 24 Kingston St.; knit  
goods and patent hosiery.

Arlington Mills, 78 Chauncy St.; dress  
goods and yarns.

Arnold, Constable & Co., 78 Chauncy St.;  
dress goods, silks, laces, white goods,  
mattings, rugs, etc.

Austin, H. A. & Co. (mfrs. agts.), 68  
Essex St.; knit goods.

Bailey, Oscar L. & Co., 18 Kingston St.;  
silk, wool and worsted mittens, knit  
goods.

Baker Underwear Co., 77 Bedford St.;  
knit goods.

Battelle, Hurd & Co., 100 Arch St.;  
woolens and underwear.

Bernheimer, Jacob S. & Bro., 116 Bedford  
St.; manufacturers and converters of  
cotton goods.

Best, Edward H. & Co., 222 Purchase St.;  
machinery blanketings, mill supplies.

Blake & Stearns, 57 Summer St.; wool-  
ens.

Bliss, Fabyan & Co., 100 Summer St.;  
prints, and general line domestic cot-  
tons, underwear and hosiery.

Boston Thread & Twine Co., 178 Devon-  
shire St.

Botany Worsted Mills; C. D. Whitehead,  
agent, 67 Chauncy St.

Bowden, J. G. & Son, 65 Bedford St.;  
narrow fabrics.

Bradley, Wm. & Co., 683 Atlantic Ave.

Brainerd & Armstrong, 68 Essex St.

Cabot, Jones & Kelly, 78 Chauncy St.;  
blanketings and dry goods.

Cameron, A. J. & Co., 620 Atlantic Ave.;  
yarns.

Carlin & Co., 67 Chauncy St.; yarns and  
general cottons.

- Chapman & Campbell, 78 Chauncy St.; knit underwear.
- Chase, L. C. & Co, 129 Washington St; blankets, robes, furniture plushes, etc.
- Chatman, H. L. & Co, 110 Summer St; dress goods and prints.
- Cheney Bros., 79 Chauncy St.; silks.
- Clement, Soule & Co., 13 Chauncy St.; woolens.
- Cobb, Reed & Co, 79 Summer St; woolens.
- Comey, W. A., 44 Bedford St.; converters of cottons.
- Conant, C. E., 77 Bedford St.
- Continental Mills Co, 31 Bedford St; Chas. H. Wood, treas.
- Contoocook Mills Co., 137 Kingston St.; hosiery and underwear.
- Converse, Stanton & Co, 62 Franklin St; cotton and woolens.
- Cooley, Turnbull & Co, 116 Bedford St; dress goods, knit goods and woolens. H. Ware Lincoln, agent.
- Courtenay, C. S., Jr. & Co., 12, 14 Columbia St.; cottons, velvets and woolen yarns.
- Croll, Albert Ivins, 85 Essex St.; cotton yarn.
- Cromwell Bros., 44 Bedford St.; cotton white goods.
- Crooks, John W., 77 Bedford St.; general yarns.
- Danforth, Clark & Co, 144 Essex St; converters of cotton goods.
- Deering, Milliken & Co, 110 Summer St.; flannels, repellents, cassimeres, cloakings, etc.
- DeMauriac, P. H., 78 Chauncy St; cotton yarns.
- Dennis, C. W., 76 Bedford St.
- Dews, F. Gifford, 67 Chauncy St.; Mens' wear, ladies dress goods, and silk linings.
- Double, Geo. E. & Co., 655 Atlantic Ave; bats, etc.
- Dudley, Battelle & Hurd, 100 Arch St.; duck, sheetings, shirtings, cassimeres, suitings, ginghams and dress goods.
- Erlanger, N., Blumgart & Co. (N. Y.), 67 Chauncy St. (M. H. Mintz, rep.)
- Estabrooks, E. J. H., 109 Kingston St, knit underwear.
- Ewing & Co., 44 Bedford St.
- Faulkner, Page & Co., 91 Bedford St.; flannels, blankets, denims, dress goods and prints.
- Fillebrown, Chas. B. & Co., 85 Essex St.; wholesale commission house.
- Fish, Wm. Jr. & Co. (N. Y.), 67 Chauncy St; cotton goods.
- Floyd Bros. & Co. 78 Chauncy St; wad-knit, cottons, etc.
- Ford, R. J. & Co, 109 Kingston St; Infants' fine knit shirts, bands, etc.
- Foster, F. A. & Co, 72 Franklin St.; sheetings, shirtings, woolens, upholstery, and drapery goods.
- Gardner, Geo. W, 67 Chauncy St; commission merchant.
- Garner & Co. (N. Y.), 67 Chauncy St; prints.
- Godshalk, The E. H. Co, 77 Bedford St; knit goods.
- Grant, Lincoln, 78 Chauncy St.; cottons.
- Greeley, Cushman & Record, 88 Franklin St.; woolens.
- Guild, Chester, 77 Bedford St.; commission merchant.
- Hall, J. B., 31 Bedford St.; general.
- Hardenbrook & Webb, 78 Chauncy St; commission merchants.
- Harding, Whitman & Co., 78 Chauncy St.; worsted dress goods, fine cotton goods, worsted and cotton yarns, and worsted tops.
- Harris Co, The; converters of cotton goods.
- Hewins, E. D., 72 Lincoln St.; cottons.
- Holden, Leonard & Co, 72 Lincoln St; woolens.
- Hough, O. E. & Co., 133 Essex St; woolens.
- Howe, F. A., 78 Chauncy St.; linens.
- Hunt, Glidden & Co, 77 Bedford St; hosiery, gloves and neckwear.
- Iselin, Wm. & Co. (N. Y.), 85 Essex St.; general.
- Joy, Langdon & Co, 99 Chauncy St; cottons, prints, hosiery, dress goods, cassimeres and worsted goods.
- Kellogg, Chas. P. F. & Co., 85 Essex St.; commission merchants.
- Kelly, Charles P., 78 Chauncy St; silk yarns.
- Kelly, Thomas & Co, 89 Chauncy St; manufacturers of blankets, etc.
- Knitting Mills Trading Co. (N. Y.), 68 Essex St.; underwear.
- Kremer & Strubing, 77 Bedford St.; cotton goods.
- Kunhardt & Allen (N. Y.), 78 Chauncy St.; woolens.
- Landers Bros., 145 Pearl St.; converters of cottons and jute goods.
- Lane, J. H. & Co, 110 Summer St; cotton fabrics and yarns.
- Lawrence & Co., corner Devonshire and Franklin Sts.; prints and fancy cottons, dress goods, sheetings, sheets, pillow cases, bolsters, knit goods and hosiery.
- Lawton, Herbert & Co, 220 Devonshire St; woolens.
- Lawton, Wm. A., 78 Chauncy St; underwear and hosiery.
- Lewis, H. & W. H., 76 Bedford St, general.
- Linen Thread Co., 226 Devonshire St, linen and cotton threads. Representing: The Barbour Bros. Co; Finlayson, Bousfield & Co.; W. & J. Knox; J. R. Leeson & Co; Marshall Bros.
- Locke Bros, 134 Lincoln St; flax threads.
- Locke, W. W., 67 Chauncy St.
- Loeb & Schoenfeld (N. Y.), 67 Chauncy St.
- Lowe, Donald & Co., 100 Chauncy St.; foreign woolens.
- Mackintire, Lawrie & Co, 262 Devonshire St; foreign linens and jute.
- Mackintosh, Taft & McKenney, 56 Franklin St.; woolens.
- Marston, J. A. & Co., 116 Bedford St.; woolens.
- Masters, Chas. A. & Co., 68 Essex St.; hosiery and knit goods.
- Mellen, C. P., 116 Bedford St.; cottons.
- Meyer, John C. & Co., 87 Summer St.; sewing silks, spool cotton and machine threads of all kinds.
- Meyer, Wm. & Co. (N. Y.), 76 Chauncy St. (A. W. Sparrow, reprte.)

- Miller, Geo. A, 38 Lincoln St; hosiery and knit goods.
- Minot, Hooper & Co, 110 Summer St; sheetings, shirtings, drillings, etc.
- Mitchell, James E. & Co, 76 Summer St; yarns.
- Moravia Mills, Liberman, Levi & Co., 77 Bedford St.; cotton goods.
- Morrill, F. C., 31 Bedford St; hosiery and underwear.
- Morse, Walter R, & Co, 131 Kingston St; commission merchants (cottons).
- Murphy, Chas. F. & Co, 26 Chauncy St, yarns.
- Neebe, Lawrence, 33 Bedford St; hosiery and underwear.
- Nevins Co, The, 78 Chauncy St; tickings, denims, domets, awnings and cotton dress goods; also, cotton and linen crases.
- New England Cotton Yarn Co., 77 Bedford St.
- New England Thread Co, 67 Chauncy St; threads.
- Noera, J. F., 119 Summer St.; Woolens.
- Noone, Wm. R. & Co., 102 South St., roller slasher cloths.
- Noyes, Bausher & Gerrish, 78 Chauncy St; cottons.
- Parker, Wilder & Co, 4 Winthrop Sq; flannels, woolens, dress goods, sheeting and quilts.
- Payson, W. A., 67 Chauncy St.
- Pingree, W. J, 78 Chauncy St; commission merchant.
- Poore, Geo. W., 21 Columbia St.; hosiery.
- Porter Bros. & Co., 72 Lincoln St.; hosiery, knit goods and small wares.
- Prendergast, J. M. & Co. (brokers), 66 State St.; cotton goods and yarns.
- Prince, S. D. & Co. (jobbers and importers), 78 Chauncy St.; gloves and handkerchiefs.
- Rice, Wm. M, 78 Chauncy St; commission merchants.
- Robeson, Louis, 78 Chauncy St; cotton goods.
- Samson Cordage Works, 115 Congress St; braided cords and twines.
- Sargent, Wingate P., & Babcock, 71-75 Chauncy St.; sotton linings, etc.
- Singleton, E. J. & Co., 68 Essex St.; worsted goods.
- Slater, S. & Sons, 77 Bedford St; cottons and woolens.
- Smith, Hogg & Co., 140 Essex St.; general line cottons, also carpets and flannels.
- Smith, Joel H., 67 Chauncy St.; woolens.
- Solls, A. J. Jr. Co, 179 Devonshire St; yarns of all kinds.
- Solis & Co, 620 Atlantic Ave; wools and yarns.
- Soule, G. E. & Co, 67 Chauncy St; commission merchants.
- Soule, W. H. H., 67 Chauncy St.; commission merchants.
- Spool Cotton Co., The, 125 Kingston St.; threads.
- Sprague, W. F. & Co., 76 Chauncy St.; commission merchants.
- Sterling Thread Co., 105 Summer St.; shoe threads.
- Stevens, J. P. & Co., 78 Chauncy St.; dress goods.
- Stoddard, Haserick, Richards & Co., 152 Congress St.; general.
- Townsend, E. M. & Co., 76 Chauncy St.; cottons and knit goods.
- Treat & Converse (formerly Coffin, Altemus & Co.), 31 Bedford St; cottons and woolens; W. M. Whiting, agent.
- Velutina Bias Co (N. Y.), A. A. Dleter, Agt., 67 Chauncy St.
- Victorson, S. W. & Co., 31 Bedford St.; braids, linings, etc.
- Ware, Bruce R. & Co., 73 Federal St; twines, threads, marlines, sash cords, spool tapes, etc.
- Watson & McWiggin, 114 Bedford St.; linen laces, embroiderles, vellings, novelties.
- Wellington, Sears & Co., 202 Devonshire St.; successors to N. Boynton & Co., cotton duck, drills, sheetings.
- Wendell, Jacob & Co, 78 Chauncy St; woolens.
- Wendell, Fay & Co, 56 Summer St; cloths, flannels, coatings and cassimeres.
- Wheaton, Geo. B., 31 Bedford St; woolens.
- Wheelwright, Eldredge & Co, 70 Franklin St; prints, cottons, gingham and hosiery.
- Whiting, W. M., 31 Bedford St.; dry goods, gingham, etc.
- Whitman, Clarence & Co. (N. Y.), 68 Essex St.
- Whitman, R. L., 28 Binford St.; cottons.
- Wilbur, Edward P, 11 Kingston St; bats, twine, pocketings, cotton flannels, etc.
- Wilcox, Edwin A, 67 Chauncy St.
- Williams, H. P. & Co., 39 Avon St.; silks and woolens.
- Woods, Joseph W. & Son, 31 Bedford St.; cloth finishers, cotton goods.

---

### Charleston, S. C.

---

Charleston Export and Commission Co.,  
30 Hayne St.

Wagner & Gibbs, 37 Pinckney St; cotton goods, hosiery, underwear, yarns.

## Charleston Export and Commission Co.,

### SELLING AGENTS FOR MILLS

Manufacturing Cottonades, Cheviots, Sheeting, Shirting, Drilling, Duck, Kerseys,  
Plaids, Tickings, Hosiery, Towels, Seine, Twine, Cotton Batting,  
Knitting Cotton, Ball Thread, Wrapping Twine

Office and Sample Room, 30 Hayne Street, Charleston, S. C.

## Chicago.

- Adams, M., 252-54 Market St.; converters of cotton goods; (New York office, 21-23 Waverly Place).
- Alborn, Heniek & Co., 232-234 Fifth Ave.; notions.
- Anderson, E. D., Medinah Bldg.; cottons and woolens.
- Bacon & Co, 221 Fifth Ave. (see New York)
- Biddle, G. W. A, 185 Van Buren St.
- Bliss, Fabyan & Co, 237 Fifth Ave. (see New York.)
- Boessneck, Broesel & Co., 237 Fifth Ave.; importers of dress goods.
- Brown & Ball Co., The, 237 Fifth Ave.; underwear and hosiery.
- Buckingham, Paulson & Co., 230 Fifth Ave.; yarns. (see New York.)
- Chase, L. C. & Co., 147 Fifth Ave.; horse clothing.
- Cheney Bros., 239 Fifth Ave.; silks.
- Clark, R. F., 237 Fifth Ave.; underwear and specialties.
- Coe, D. A., 235 Franklin st.; commission.
- Coe, S. D., 235 Franklin St.; commission.
- Converse, Stanton & Co., 221 Fifth Ave.; woolens.
- Cox, L. B., 237 Fifth Ave.; knit goods.
- Cruttenden, Thos. S., 252 Monroe St.; commission.
- Curtiss & Warren, 185 Van Buren St.; (New York office 214 Church St.); commission.
- Danforth, Clark & Co., 245-7-9 Jackson Bldg.; cotton.
- Deering, Milliken & Co., 232 Fifth Ave. (see New York.)
- Doane, Thos. H., 211-13 Madison St.; woolens, cottons, duck coats.
- Eisendrath & Rosenberg, 215 Van Buren St.; commission.
- Elmer, Theo. H., 220 Madison st.; notions and hosiery.
- Epstein, Max N., 240 Franklin St.
- Erler, R. G. & Co., 173 Adams St.; commission.
- Feder, L. & Co., 899 Milwaukee Ave.; cotton goods.
- Field, Samuel G., 317 Medinah Temple; cotton goods.
- Field, R. I. & A. C., 211 Jackson Bldg.; woolens.
- Fieldhouse, Walter, 237 Fifth Ave.
- Fleischer, S. B. & B. W., 234 Franklin St.; yarns.
- Foster, F. A. & Co., 234 Fifth Ave.; commission.
- Foster, G. H. & Co., 150 Fifth Ave.; silks and braids.
- Freeman, W. H., 235 Franklin St.; woolens.
- Garner & Co., 252 Monroe St.; commission. (see New York.)
- Graves, John M., 221 Fifth Ave.
- Greely, Cushman & Record, 235 Franklin St.; woolen. (see New York.)
- Gross, G. M., 211 Jackson Bould.; cotton and woolen goods.
- Harris, S. G., 221 Fifth Ave.
- Haynes, L. W., 237 Fifth Ave.
- Holden, Geo. H., 237 Fifth Ave.; cottons.
- Holland & Webb, 269 Dearborn St.; yarns. (see New York.)
- Helmecke, Carl, 922 Medinah Temple; hosiery and underwear.
- Hoyt, G. W. & Co., 207-209 Monroe St.
- Hubbard, Smith & Co., 260 Bright St.
- Irving, Robert A., 238-240 Franklin St.; commission.
- Jenkins, Kreer & Co., 207-11 Jackson Bould.; commission.
- Jerome, Frank, 966 Jackson Bould.; linings. (New York office 54 Leonard St.)
- Johnston, Price & Co., 260 Fifth Ave.; underwear.
- Jones, N. H. & Co., 235 Franklin St.; commission.
- Jones, O. L., 211 Jackson Bould.; woolens, hosiery, sweaters.
- Kelly, Thomas & Co., 149 Fifth Ave.; blankets. (see Boston.)
- Klapp, W. H., 221 Fifth Ave.
- Kremer & Strubing, James H. Morrison, agt.; 147 Fifth Ave.; cottons. (see Phila.)
- Kunhardt & Allen, 237 Fifth Ave.; commission.
- Lane, J. H. & Co., 237 Fifth Ave.; cotton goods.
- Lawrence & Co., 237 Fifth Ave.; commission. (see Boston.)
- Lewis, E. & H. W., 237 Fifth Ave.; silks, satins, etc.
- Lidgerwood Bros., 237 Fifth Ave.
- Lothrop, L., 237 Fifth Ave.
- Mann, H. V. & Co., 211 Jackson Bould.; woolens, plushes, cottons, silks, satins.
- Marshall, H. L. & Co, 175 Dearborn St.
- McDonald, J. B., & Co., 235 Franklin St.; woolens.
- McPherson & Lawrie, 235 Franklin St.; commission.
- Milloy, John & Co., 207-209 Monroe St.; fine cotton linings, canvass and etamines.
- Minot, Hooper & Co., 237 Fifth Ave.
- Neff, A. W., 235 Franklin St.
- Peck & Co., 167 Adams St.
- Poor Bros., 169 Jackson Bould.; cotton.
- Pratt & Pratt, 237 Fifth Ave.
- Putnam, Hooker & Co., 212-18 E. Third St.; cotton and woolen domestics. (see Cincinnati.)
- Record, M. L. & Co., 235 Franklin St.; commission.
- Remick & Newell, 192-194 Van Buren St.; commission.
- Rice, Sidney W., 237 Fifth Ave.; dress goods.
- Rothschild & Stern, 237 Fifth Ave.; underwear and hosiery.
- Rudert, Emil, 237 Fifth Ave.
- Schey, Sylvan, 219 Van Buren St.; cloakings, satins.
- Shaw, T. A. & Co., 254 Market St.; commission.
- Simpson, Wm., Sons & Co., 233 Jackson Bould.; prints.
- Slater, S. & Sons, 185 Van Buren St.; commission. (see New York.)
- Smith, Hogg & Gardner, 237 Fifth Ave.; cotton and linen.



- Appel, M., 57 Leonard St.; hosiery, gloves and knit goods.
- Arnstaedt & Co., 68 Greene St.; silk importers, general line cloths.
- Auffmordt, C. A. & Co., 33 Greene St.; dress goods, woolen hosiery, silks, velvets, upholstery and seal plushes.
- Aukum, Herman & Co., 31 Thomas St.; cotton handkerchiefs.
- Bachmann, Emmerich & Co., 530 Broadway; woolens and silks.
- Bachmann, L. & Co., 86 Franklin St.; woolens.
- Bacon & Co., 92 Franklin St.; woolens, etc., linen and jute goods, Jas. Smlton, Geo. E. Borcham.
- Badger, W. S. & Co., 76 Leonard St.; flannels and dress goods.
- Bahnsen, C., 462 Broome St.; woolens and worsteds.
- Bailey, Floyd & Son, 71 Worth St.; cottonades.
- Baily, Joshua L. & Co., 39 Thomas St.; jeans, doeskins, cotton worsteds, denims, camlets, flannelettes, domets, shakers, gingham, dress goods, bleached cottons, sheetings, brown cottons, printed fabrics and linings.
- Baker, Carver & Morrell, 75 Front St.; duck, etc.
- Baldwin, F. H., 1256 Church St.; cotton goods for converters.
- Bale & Manley, 260 W. Broadway; yarns.
- Barnes & McGary, 63 Leonard St.; knit underwear.
- Barnett, A. & Co., 69 Worth St.; cotton piece goods and cotton handkerchiefs.
- Barnsville Mfg. Co., 910 N. Y. Life Bldg.; cotton yarns.
- Bartlett & Anderson, 47 Leonard St.; cottons and woolens.
- Barton, F. C., 56 Franklin St.; narrow fabrics, tapes, ribbons, etc.
- Bateson & Dowd, 78 Franklin St.; hosiery, knitted goods and shirts.
- Batten, Harrison & McMaster, 57 Franklin St.; woolens and cottons.
- Battelle, Hurd & Co., 53 Worth St.; woolens.
- Bauendahl, H. & Co., 78 Leonard St.; woolens, foreign and domestic goods.
- Bausher, C. L. & Co., 34 Thomas St.; cotton domestics.
- Baxter, Alex. R. & Co., 60 Lispenard St.; auction dry goods, sales Tuesday and Friday.
- Bayne, W. H., 53 Worth St.; gingham and turkey red damask; agent, Oakland Mfg. Co.; wool kerseys.
- Bedell, E. W., 93 Bleeker St.; braids and tapes.
- Bell & Burke, 621 Broadway; woolens.
- Berlin, Frank B., 43 Leonard St.; mfgs. agt.
- Bernhard, B. & Son, 373 Broadway; silks, dress goods and shawls.
- Bernheimer, Jacob S. & Bro., 31 White St.; converters of cotton goods.
- Bernheimer & Walter, 51 White St.; converters of cotton goods.
- Bier, A. M. & Co., 721 Broadway; tailors' trimmings, tapes.
- Bigelow, Elliott, 53 Worth St.; woolens.
- Bell & Harris, 256 Church St.; woolens.
- Black, John, 31 East 17th St.; upholstery goods, curtains and carpets.
- Bliss, Fabyan & Co., 32-34 Thomas St.; prints, M. C. D. Borden; cottons, E. H. Baker; cotton hosiery, F. L. Matthews.
- Block, E. H. & Co., 51 Greene St.; silks and satins.
- Bluhm, L., 467 Broadway; worsteds and woolens.
- Blum, J. A., 37 Greene St.; silks.
- Boessneck, Broesel & Co., 468 Broome St.; woolens, importers of dress goods, etc.
- Bolger & Brewster, 256 Church St.; knit underwear.
- Boyd, E. F., N. Y. Life Bldg.; hosiery.
- Braman & Valentine, agents, 88 Franklin St.; woolens.
- Branderwalsh Co., 89 Worth St.
- Brennan, John, 31 Wooster St.; commission.
- Briggs, John F. & Son, 57 Worth St.
- Brown, C. A. & Co., 56 Worth St.; underwear and hosiery.
- Brown, James, Freeman Co., 73 Franklin St.; commission.
- Brown, M., Sons & Co., 8 Thomas St.; jeans, cottonades and flannels.
- Buck, Thos. & Co., N. Y. Life Bldg.; hosiery.
- Buckingham, Paulson & Co., 83 Leonard St.; warps, yarns, twines, bats, quilts and special cotton fabrics.
- Butler, S. S., 83 Greene St.; Silks.
- Burgess W. H. & Co., 40 Leonard St.; worsted dress goods and silks.
- Burke, J. Franklin & Co., 621 Broadway; woolens.
- Burrell, Sam'l P. & Co., 258 Church St.; knit underwear.
- Burrows, J. G., 343 Broadway; curtains and upholstery goods, carpets and rugs.
- Buss, H., & Co., 467 Broadway; buttons, etc.
- Cabot, Jones & Kelley, 69 Worth St.
- Caesar, H. A. & Co., 45 Leonard St. & 20 Greene St.; importers of silk, woolens and dress goods.
- Carberry, Jos. A., 55 Leonard St.; knit underwear.
- Carey, Bayne & Smith Co., 88 Leonard St.; bleached and brown cotton and tickings.
- Carpenter, S. S., 256 Church St.; hosiery and gloves.
- Carthart, John, & Co., 115 Franklin St.; towels, etc.
- Cassard, J. D. & Son, 69 Worth St.; cottons.
- Catlin & Co., corner Broadway & Leonard St.; cottons, woolens, domets, canton flannels, cottonades, jeans, hosiery and cotton yarns.
- Chaffee, Edward J., 256 Church St.; hosiery and underwear.
- Chaffee, Morehouse & Co., 43 Worth St.; hosiery and jackets principally.
- Chamberlain, Wm. H., 256 Church St.; knit goods, Swiss ribbed underwear, agent for Vesta Knitting Mills.
- Chase, L. C. & Co., 341 Broadway; blankets, robes, plushes and horse blankets.
- Cheney Bros., 477-481 Broome St.; silks.
- Chester Woolen Co., 715 Broadway; woolens.

- Childs, Wm. H., 47 Worth St.; bleached goods and domests.
- Childs, H. C. & Co., 18 Thomas St.; commission.
- Clabburn, E. H., 53 Franklin St.; dress goods.
- Clafin, H. B. Co., 224 Church St.; cottons.
- Clark & Camplon, 63 Leonard St; cottons.
- Cochrane Mfg. Co., 87 Worth St.; cotton goods.
- Cohen, A. B., 393 Broadway; hosiery.
- Cohen & Balthaser, Silk Exchange, Broadway and Broome St; silks.
- Cohen & Bros., 143 Greene St.
- Cohen, J. A., 74-76 Worth St.
- Cohen, S. B., 63 Leonard St.; woolens.
- Cohen & Eisenberg, 60 Leonard St.; woolens.
- Cone Export & Commission Co., 74-76 Worth St.; plaids and checks.
- Cone & Brush, 117 Franklin St.; cotton goods.
- Conover, C. E. & Co., 101 Franklin St; tapes, bindings and hosiery, the Warner Hose Supporter.
- Conrad, W. B., & Co., 52 White St.; cottons and linens. Foreign goods.
- Converse, Stanton & Co., 83 Worth St; cotton and printed goods, damask, hosiery, woolens and woolen dress goods.
- Cooke, James W. & Co., 48 Leonard St; glinghams, dress goods and flannels.
- Cooley, Martin I., 100 Worth St; bleached and brown muslins and percales.
- Cooley, Turnbull & Co., 113 Duane St.; woolens, underwear, domestic dress goods and steamer rugs.
- Copeland, Chas. C. & Co., 45 Worth St.; cottons.
- Copeland, Pray & Tuttle, 43 Worth St.; cotton goods.
- Cramer, Geo. E. & Bro., 76 Leonard St.; knit wear, hosiery.
- Creighton & Burch, 10 Thomas St.; cottons and lace curtains.
- Critten, Clift & Co., 48 Leonard St; men's and ladies' underwear.
- Cromwell Bros., 355 Broadway; cotton white goods.
- Crosby, A. B., 467 Broadway; laces and embroideries.
- Crowell, D. L., 346 Broadway; mfrs. agt., knit goods.
- Culin, C. G., 346 Broadway; hosiery and gloves.
- Cumming & Becker, 106 Franklin St.; knit goods and hosiery.
- Curtis & von Bernuth Mfg. Co., 95 Chambers St.; horse clothing.
- Curtiss & Warren, 214 Church St.; cottons, woolens and knit goods. (head office Chicago.)
- Dalbey, H. C., 115 Worth St.; upholstery goods, carpets, matings and curtains.
- Danforth, Clark & Co., 75 Leonard St; cotton goods.
- Davis, Chas. J., 28 Greene St.; silks.
- Davis, T. J. & Co., 45 Leonard St.; linens.
- Day & Kenyon Co, 260 Church St; knit underwear.
- Day, N. B., 66 Leonard St.; cottons and woolens.
- Deering, Milliken & Co., Worth St.; woolens, flannels, dress goods, cloakings and cotton sheetings.
- Derby, W. E. & Co., 75 Worth St.; carriage cloths.
- DeVeer, H., 260 W. Broadway; yarns.
- Devoe & Peck (Dept. Wm. Iselin & Co.), 5 Greene St.; foreign and domestic woolens, flannels and crashes.
- De Yonge, S. E., 66 Greene St.; cotton braids, trimmings, etc.
- Dickey, W. J. & Sons, 88 Leonard St; cottons & woolens.
- Dickson, Peck & Palmer, 54 Leonard St.; cottons.
- Dobson, John and James, 73 Worth St.; carpets, woolens. Manager, Mr. C. H. Wade.
- Doff & Benton, 78 Franklin St.; linens.
- Double, G. E. & Co., 61 Lispenard St.; cottons.
- Doughty, J. W., 256 Church St.; knit underwear.
- Doul, Miller & Co., 75 Worth St.
- Downing, Clark & Co., 568 Broadway; woolens.
- Dresser & Co, 568-574 Broadway; woolens.
- Dresser & Olmstead, 343 Broadway; silks, tapes, bindings, trimmings and ribbons.
- Dryforts, Otto E., 274 Church St.; hosiery.
- Dry Goods Commission Co, 66 Grand St; dress goods.
- DuBols, J. Vanwyck, 43 Leonard St; hosiery.
- Dunn, R. P., 43 Leonard St.; knit underwear.
- Duren, Geo. B. & Sons, 57 Leonard St; cottons.
- Dusenbury, C., Coles & Co., 396 Broadway; importers of cloths and carriage trimmings.
- Duval & Cone, 81 Worth St.; commission. Domestic department, Hardt Von Bernuth Co.
- Eastern Mfg. Co., 393 Broadway; upholstery.
- Edward & Allen, 54 Leonard St.
- Eichmann & Sternberg, 539 Broadway, cor. Spring St.; cotton yarns.
- Einstein, S. & Co., 75 Franklin St.; underwear and hosiery.
- Elliott, James & Co., 370 Broadway, linens, etc.
- Elmore, Chas., 69 Worth St., white goods, printed goods, dyed goods, principally gray cottons.
- Elms & Co., 40 White St.; commission.
- England, James W., 783 Broadway; hosiery and underwear.
- Ernscliffe Worsted Mills, 377 Broadway.
- Ernststein, S. & Co. 75 Franklin St; hosiery and underwear.
- Erstein, L. & Bro., 124 Spring St.; silk and ribbons.
- Ewing, B. M. & Co., 47 Worth St., woolens and cotton worsteds.
- Farber, F. M. & Co., 377 Broadway; underwear and hosiery.
- Farber, H. J., Drewry & Co., 58 Leonard St; knit underwear, bleached and colored cottons.
- Farish, Stafford Co., 71 Leonard St. (Conyers B. Finkel, Phila.)

- Farnum, John & Co., 46 Leonard St.; ticks.
- Farrell, T. P. T., Wool Exchange Bldg.; knit goods.
- Farrell & Murray, N. Y. Life Bldg.
- Faulkner, Page & Co., 58 Worth St.; prints, flannels and cottons.
- Faure, J. P., N. Y. Life Bldg.; hosiery
- Fawcett, Alfred, 115 Worth St.; importer.
- Fawcett, Hughes, 115 Franklin St.; linen yarns.
- Field, Chapman & Co., 427 Broadway, (auctioneers).
- Fillebrown, C. B. & Co, 60 Leonard St; woollens.
- Fischer, W. M., 458 Broadway; dress goods.
- Fish, Wm, Jr, Co, 60 Leonard St; cotton goods brokers.
- Fithian, J. H. & Co., 71 Greene St.; corduroy, umbrella cloths, cottons, velveteens, satins and cotton muslins.
- Fleitmann & Co., 484 Broome St. and 53 Worth St.; laces and embroideries.
- Floyd Bros, 132 W. Broadway; cotton goods.
- Fogg, T. B., N. Y. Life Bldg.; underwear.
- Folkard & Lawrence, 725 Broadway; woollens and corduroys.
- Forstmann & Co., 87 Worth St.; woolen.
- Foster, F. A. & Co. 66-68 Worth St; upholstery goods, draperies and linings.
- Frankenberg, H. E., 457 Broome St.; importers of worsted yarns.
- Franklin, E. P., N. Y. Life Bldg.; hosiery.
- Galey & Lord Mfg. Co., 329 Broadway; cottons and woollens.
- Gardner, M. & Co., 270 Church St.; German, Scotch and Irish linens.
- Garner & Co, 10 Worth St; various brands of printed and dyed cotton goods.
- Geiger, Martin, 63 Leonard St.
- Gernshym, Henry & Bro., 73 Franklin St.; cardigan jackets.
- Gill, Wm. P. & Co., 18 Greene St.; silks and ribbons.
- Givon, John S. & Co., 97 Franklin St.; hosiery, gloves, blankets and skirts.
- Givon Mfg. Co., 71 Leonard St.; fine cotton goods.
- Globe Woollen Co., 379 Broadway; fine worsteds and woollens; E. T. Batsford, treas.; Stanley H. Ray, agt.
- Golden, S. Herbert, 95 Franklin St.; woollens.
- Goldstein & Newberger, 83 Grand St.; woollens.
- Goodwich, E. J., N. Y. Life Bldg.; underwear.
- Graff, Isaac P., & Co., N. Y. Life Bldg.; underwear and hosiery.
- Groff & Co., 106 Spring St.; importers of woollens, dress goods and silks.
- Greeley, Cushman & Record, 63 Leonard St; woollens.
- Greer & Hutton, 71 Franklin St.; tapestry, towelings, chenille curtains and rugs.
- Gregory, H. B., Textile Bldg., Leonard and Church Sts.; underwear and sweaters.
- Grinnell, Willis & Co., 44 Leonard St.; plain cotton goods.
- Griswoldville Mfg. Co., 51 Leonard St.; cottons; E. D. Griswold, pres.; shirts.
- Guenther, T. & Co., 43 Leonard St.; silk hosiery (J. P. Nissen, agt.)
- Gutmann, C. & Co., 102 Franklin St.; Swiss ribbed underwear.
- Hahlo, H. & Co., White St.; woollens.
- Haight, A. S. & Co, 49 Leonard St; knit underwear.
- Haines & Bishop, 78 Worth St.; cottons, sheetings and drillings.
- Hall, E. B., 53 Worth St.; woollens.
- Hall, John R. & Co., 256 Church St.; cotton goods, W. F. Hall; linens, dress linings and tailors' trimmings.
- Hall & Bishop, 80 Greene St.; dress goods and velveteens.
- Hambrecht, R. J., N. Y. Life Bldg.; knit goods.
- Hamilton, Chas. H., 71 Worth St.; woollens.
- Hamilton, E. H. & Co., 113 Worth St.; domestics, bags, bats, twine, wicks, comfortables and carpet linings.
- Hamilton, E. H., 113 Worth St.; cottons.
- Hamilton, J. H. & Co, 275 Church St; cotton worsteds, binding, tape, picture wire, braided cotton, and other sash cords.
- Hamilton & McGlynn, corner Church and Franklin Sts.; general.
- Hanford, E. G., 621 Broadway; agent for Clinton Mills, Clinton, Mich.; woollens.
- Harding, Whitman & Co, 80 Leonard St; yarns, dress goods and cotton linings.
- Hardt, Von Bernuth & Co., 477 Broome St.; cotton, woolen, worsted and silk yarns.
- Hardt & Lindgens, 58 Greene St. & 53 Worth St; woollens, silks, velvets and ribbons.
- Harper, Orlando M., 108 Worth St.; brown and bleached cotton sheeting and buntings.
- Harrington & Waring, 71 Franklin St.
- Hayes, O. H. & Co, 10 Thomas St; woollens, worsteds, chevots and freizes.
- Hazard, Thos. T. & Son, 70 Worth St; woollens and worsteds.
- Hecht & Camp, 274 Church St.
- Hecht, S. L. & Co., 50 Leonard St.; woollens.
- Hedden, W. A. & Co., N. Y. Life Bldg.; wool hosiery.
- Heinze, Otto Co., 81 Franklin St.; hosiery and cotton goods.
- Heller & Long, 80 Worth St.
- Hempstone & Day, 22 White St.; dress goods.
- Henson & Small, 458 Broadway; lace curtains.
- Hermann, M., 236 Church St.; cottons.
- Herrmann, S., 51 Franklin St.; shawls.
- Hillyer, E. T., 349 Broadway; chenille goods, quilts and upholstery goods.
- Hinchman, W. H. & Co, 377 Broadway, cotton goods.
- Hinchman, Vezin & Co, 349 Broadway; hosiery.
- Hinman Bros, 359 Broadway; upholstery, curtains, jerseys, Kensington Felt Co.



- Hinze, Otto, Co., 81 Franklin St.; knit goods.
- Hirschfeld, J. B. & Co., 256-258 Church St.; underwear, hosiery, etc.
- Hockanum Association, 64 Worth St.; woolens.
- Hoeninghouse & Curtiss, 473 Broome St.; silks.
- Holland & Webb, 457 Broadway; cotton, worsted and silk yarns, embroideries.
- Holland Mfg. Co., 561 Broadway; silks.
- Hope & Trippe, 274 Church St.; cottons.
- Horstmann, Wm. H. Co., 459 Broadway; mfrs. yarns, fancy goods, military equipments.
- Horton, B. W., 341 Broadway; cotton.
- Horton, Chas. E., 43 Leonard St.
- Howell, M. D. & Co.; importers.
- Hunter Mfg. Co., 69 Leonard St.; cottons.
- Hyde & Jacobson, 53-55 Worth St.
- Hyde, A. G. & Sons, 361 Broadway; cotton goods.
- Ijams, J. T., 53 Worth St.; cottons and woolens.
- Ingalls, F. Abbott, 61 Leonard St.; cotton goods.
- Iselin, Wm. & Co. 1 Greene St.; domestic woolen department, J. B. Lorge.
- Jacobs, Chas. H., 260 Church St.; cotton goods.
- Jaeger & Timme, 413 Broome St.; silk plush and upholstery goods.
- Jamestown Worsted and Woolen Mills, 260 Church St.; Hall & Co.
- Jenkins, C. P., 51 Leonard St.; yarns, shirt waists, agents for Zaneville Woolen Mfg. Co.
- Jenkins, S. P., 108 Worth St.; cottons.
- Joffe & Perkins, 89 Leonard St.; cotton goods.
- Joy, Langdon & Co, 108 Worth St; dress goods, jacquards, serges, cassimeres, alpaca, baize, domestics, canton flannel, ticking, domests, prints, and napped goods of all kinds.
- Juilliard, A. D. & Co., 70 Worth St.; woolens, dress goods and silks.
- Kellogg, Chas. P. F. & Co., 76 Franklin St.; cottons and white goods.
- Kelley, Henry C., 548 Pearl St; warps and twines.
- Kelly, Thos. & Co, 74 Franklin St; blankets and quilts.
- Kessel, Louis, 111 Franklin St.; woolens.
- King, Chas. S., 76 Franklin St.; tapes.
- Klostermann & Baum, 434 Broome St.; woolens and silks.
- Klinkhardt & Seiffert (through Spielmann & Co); general.
- Knight, B. E. & R. 39 Worth St; W. E. Wall, agt, muslins, bleached and unbleached cotton goods.
- Knitting Mills Trading Co. H. N. Corwith, pres, 104 Franklin St; underwear and hosiery.
- Knox, J. J., 256 Church St.; cottons.
- Kohlman, Chas, 266 Church St; cotton goods.
- Kraft, Rudolph, with Greeff & Co, Spring cor. Mercer St; dress goods.
- Kremer & Strubing, 106 Franklin St.; cotton goods.
- Kunhardt & Stockton, 75 Worth St.; woolens, worsteds, overcoatings and dress goods.
- Ladd, Burling & Co., 7 Greene St.
- Lamb, Finley & Co., 256 Church St.; importers.
- Lamson, Roger & Co, 55 Leonard St; knit goods, underwear and hosiery.
- Lane, J. H. & Co, 110 Worth St; grey and converted cotton goods.
- Langford, T. H., 320 Broadway; cottons.
- Langley, W. H. & Co., 105 Worth St.; woolen and cotton goods.
- Lawrence & Co, 26 Thomas St; printed and dyed cotton goods.
- Plain cotton goods, Mr. A. Ray.
- Lawrie, Mann & Drowne, 61 Leonard St.; woolens.
- Lees, W. Sherman & Co., 52 Leonard St.; twines, wicks, etc.
- Lees, Tweedy & Co., 88 Worth St.
- Levy & Levy, 476 Broome St.; mfrs agts., knit goods.
- Lewis, Frank, 97 Franklin St.; worsteds and woolens.
- Lewis, H. & W. H. 59 Worth St; cotton and woolen goods.
- Libby, H. J. & Co., 57 White St.; woollens, shawls and dress goods.
- Lieberman, Levy & Co., Moravia Mills, 200-2 Green St.; cotton goods.
- Lima, Chas. C., 35-37 Thomas St.
- Lindner, R., 37 White St.; linens.
- Linen Thread Co., 48 White St.; yarns.
- Lings, G. S. & Co., 480 Broome St.; cotton yarns; importers.
- Locke & Alther, 99 Greene St.
- Locke, J. B. & Potts, 83 Leonard St.; white goods and damasks; importers.
- Lockwood & Co., The, 54 Leonard St.; knit goods, hosiery.
- Logan, J. P., corner Canal and Greene Sts.; white goods.
- Logie, Alexander & Co., 320 Broadway; burlaps, etc.
- Lorge, J. B. & Co., 58 Leonard St.; woolens.
- Lorraine Mfg. Co, 51 Leonard St; cottons and woolens, Geo. E. Stedman, agent.
- Mackintosh, Taft & McKenney, 55 Leonard St.; woolens.
- Maclea, R. E. & Co., 349 Broadway; importers.
- McCann, J. & Co., 26 White St.; importers of linens.
- McConnell, E., 93 Franklin St.; linens.
- McCosker, David, 20 Lispenard St.; linens and woolens.
- McIntire, W. F., 76 Leonard St.; cotton goods.
- McLean, E. L., 458 Broadway; woollens
- McManus, T. I., 64 White St.; woollens.
- Maddock, R. C., N. Y. Life Bldg.; hosiery.
- McVaugh, W. T., 61 Leonard St.; hosiery.
- Mali, H. W. T. & Co., 85 Worth St.; woollens.
- Mallory, H. Lee, 43 Leonard St.; knit underwear.
- Mandell, K. & Co., 24 Howard St.; commission export.
- Mann, S. & Co., 36 Walker St.; hosiery and underwear.
- Martin & Fischer, 48 Leonard St.; domestic woollens and cloakings.

- Martin, J. H. & Co., 256 Church St.; cottons.
- Martin, T. B., 22 Thomas St.; worsteds
- Masters, Francis R., 45 Worth St; shawls, dress goods and woolens.
- Mayer, David, 54 Worth St.; importers of white goods.
- Meinhard, M. H. & Co., 43 White St.; woolens.
- Mendelsohn & Co. 20 White St; agents for Hudson River Woolen Mills, Newburg, N. Y.
- Metcalf Bros. & Co, 59 Worth St; woolen goods, Wanskuck Co.
- Meyer, Henry L., 477 Broadway; cottons and woolens.
- Meyer, Heller & Long, 80 Worth St.; handkerchiefs, etc.
- Meyer, Jos. & Co., 128 Greene St.; yarns.
- Midgeley, James, 56 Worth St; textile fabrics for designs.
- Millius, E. & Bro., 105 Franklin St.; cottons.
- Miller, Doull & Co., 454 Broadway; dress goods.
- Minot, Hooper & Co., 123 Duane St.; Great Falls Mfg. Co., Dwight Mfg. Co., Lyman Mills and Manchester Mills; drills, sheetings, gray drills, fancy prints, woolens and worsted dress goods.
- Mitchell, Ernst & Son, 85 Leonard St.; woolens.
- Moeller & Littauer, 109 Greene St.; cotton, worsted and silk yarns.
- Mooney, G. A., 369 Broadway; hosiery.
- Morey, Wm. H., 56 Worth St.; worsteds.
- Morgan, E. A. & Co., 54 Franklin St.; yarns.
- Moss, Taylor & Co., 109 Worth St; cottons, prints, etc.
- Mueller, Ambler & Co., 369 Broadway; yarns and knit goods.
- Muir & Malone, 253 Church St; knit underwear.
- Murdock's Nephew's, 454 Broome St.; woolens and knit goods.
- Murray & Brooking, 212 Church St.; finished cotton and linen goods.
- National Yarn Co., N. Y. Life Bldg.
- Nathan, McDavitt & Cardozo, 47 Leonard St.; hosiery and underwear.
- Nawrath, J. P. & Co, 18 Lispenard St; twines, yarns, cordage, bats, candle wick and mops.
- Naylor, L. P. & Co., 76 Franklin St.; knit underwear.
- Neuss, Hesslin & Co., 43 White St.; cotton and linen.
- Nevins & Co, 212 Church St; fancy flannels, sateen tickings, cotton cassimeres, cottonades, fancy and printed domets, plain and fancy denims, shirtings, crashes, duck and golf suitings.
- Newell, C. D., 49 Leonard St; duck and drills.
- New England Cotton Yarn Co., 316 Broadway.
- Newhouse, S. H. & O. B., 53 Worth St.; woolens.
- North, J. W. & Co., 256 Church St.; ladies' ribbed underwear.
- Nostrand & Moore, 83 Worth St.; woolens and worsteds.
- Oelbermann, Dommerich & Co., Textile Bldg.; worsted and silk yarns.
- Oelbermann, Dommerich & Co., 65 Worth St.; woolen, hosiery, silk.
- Oettel & Ludwig, 469 Broome St.; dress goods.
- Ogden & Brook, 526 Broadway; woolens.
- Openhym, Wm. & Son, 105 Grand St.; silks.
- Ostrander, Frank & Co., 15 Thomas St.
- Page, H. W. A., 56 Worth St.; linens.
- Paisley Silk & Thread Co., E. J. Currie, sole agent, 89 Grand St.
- Parker, Wilder & Co, 62 Leonard St, woolens and cottons.
- Passavant & Co., 83 Greene St.; every thing in dry goods line.
- Patterson & Greenough, 245 Broadway; shawls, indigo blue and cadet uniform cloths, indigo livery cloths, carriage upholstery cloths, cords, etc.
- Peck & Palmer, 71 Franklin St.; colored cottons.
- Peier's, S. & Co., 10-12 Greene St.; silks.
- Fercival, Chas. M., 160 W. Broadway; woolens.
- Peterson, R. J., 50 Leonard St.; cotton goods.
- Pippey, B. Y. & Co, 45 Leonard St; woolens.
- Poor Bros., 21 Thomas St.; prints.
- Pope, C. H. & Co, 87 Worth St; cotton cloths; brokers.
- Porter Bros. & Co. 78 Worth St; notlons, underwear, buttons, yarns and pattern buttons.
- Putnam, Hooker & Co., Wm. G. Judkins, mgr., 108 Worth St.; cotton goods.
- Radon & Co., 32 Green St.; woolens and silks.
- Ragborg & Hyde, 55 Worth St.; woolens.
- Ransohoff, E. & Sons, 47 Lipsenard St.; Turkish towels.
- Ray & Wilson, 548 Pearl St.; wadding and buckram.
- Remy, Schmltd & Pleissner, 24 White St; woolens and hosiery.
- Renwick, John E. & Co., 377 Broadway; hosiery, sweaters, golf hose, bath robes, wrappers and general knit goods.
- Reynolds, James E. & Co., 70 Thomas St.; battings, cotton twine, bags and carpet wraps, candle wick, cotton rope and clothes line.
- Rice, A. H. & Co., 779 Broadway; sewing silks and braids.
- Richardson, J. N., Sons & Owen, 44 Franklin St.; linens.
- Riggs, G. O. & Co., 101 Franklin St.; commission.
- Riggins, Lindsey J, 47 White St.
- Robinson, Hughes & Co. (Louisville), 43 Leonard St.; ducks.
- Robinson & Brown, 112 Franklin St.; hosiery.
- Robinson & Son, 137 Greene St.; cotton yarns.
- Robison, G., Jr., 648 Broadway; mercerized yarns.
- Rockfellow, W. H. & Co., 70 Worth St; woolen goods.
- Rosenthal, G. & Son, 326 Church St; woolens.
- Rosenthal, J., 436 Broadway.
- Ross, Alex. S., 335 Broadway; hosiery and knit goods.

- Rothschild, V. Henry & Co, 43 Leonard St; shirts, shirt waists and shirtings.
- Rowe, W. H. & Son, 97 Franklin St.; knit underwear and over shirts.
- Ryan & McGahan, 85 Leonard St; chenille, tapestry, curtains and covers.
- Ryle, Wm. & Co., 54 Howard St.; silk yarns.
- Sack & Stiasny, 83 Leonard St.; woolens.
- Sahner, V. P., 346 Broadway; hosiery.
- Salkeld, A. D. & Bro., 72 Leonard St.; yarns.
- Salter, J. L., 47 Leonard St.
- Sanders, H. & Co., 260 Church St.; cotton covert cloths, cotton worsteds, stripes, jeans, crashes, cottonades, tickings, cheviots, shirtings, sheetings, plaids, domets and denims.
- Sanford, Oscar M, 214 Church St; brown cottons.
- Sawyer & Blake, 63 Leonard St.; woolen goods.
- Schachue, Louis, & Bro., 16 Lispenard St.; underwear and hosiery.
- Schaffner, W. E., 105 Worth St.; woolens.
- Schefer, Schramm & Vogel, 478 Broome St.; silk dress goods, kid gloves, shawls, velvets, domestic and foreign dress goods, hosiery, underwear, ribbons and embroideries.
- Schertlin, Edward, 75 Leonard St.; hosiery.
- Schloss, N. J. Sons & Co., 594 Broadway; woolens.
- Schmiedler, R. & Co., 594 Broadway, shirts, hosiery, etc.
- Schnabel Bros, 71 Worth St; woolei goods.
- Schoolhouse, Chas. & Son, 107 Grand St.; ribbon and silk velvets.
- Schroeder, Wm. & Co., 471 Broome St.; silks.
- Schuff, Henry, corner Church & Franklin Sts.; hosiery.
- Schwab, S. M., Jr. & Co., 46 White St.; converters of cotton goods.
- Schwarz, E. & Co., 22 White St.; woolens and corduroys.
- Scott Bros., 70 Franklin St.; underwear.
- Scott, Jas. & Sons, 73 Leonard St; linens and burlaps.
- Scott, S. M. & Co., 97 Franklin St.
- Sellers & Steele, 86 Franklin St.; hosiery.
- Seyd, Otto & Co., 57 Worth St.; dress goods.
- Shaddle, C. V., 192 W. Broadway; wooleens.
- Shaw Bros., 43 White St.; white goods.
- Sheridan, G. K. & Co. 68 Thomas St, sheetings and cotton duck.
- Sherman, Reid & Co, 62 Leonard St; white goods.
- Shoyer, D. W. & Co, 390 Broadway; knit skirts and fancy knit goods.
- Shreve & Adams, 86 Leonard St; hosiery and underwear.
- Simon, J. R. & Co., 21 Greene St.; silks.
- Simons, L. S., 56 Leonard St.
- Simpson, Wm. Sons & Co, 65 Worth St, black prints, percales, foulard, fancy prints, satines, corea madras cloth, lawns, dimities, goblin art drapery, taffetas, silkalines, etc.
- Shaw Bros., 43 White St.; importers.
- Skerry, A. T. & Co., 47 Leonard St.; yarns.
- Skidmore & Muller, 41 Greene St.; woolens.
- Slade, C. M., 65 Worth St.; cotton goods.
- Slater & Sons, 49 Worth St.; manager, J. C. Peck; commission.
- Slater Mills, Wm. A, 57 Worth St; fancy cottons.
- Sloane, W. & J., 18th St. and Broadway; carpets.
- Smith, Albert D, 35 Thomas St; cottons, towels and quilts.
- Smith & Angell, 392 Broadway; black hosiery, silesias, sateens and cambrics.
- Smith, Hogg & Co., 115 Worth St.; cottons, carpets, etc.
- Smith, Th. L. & Co., 110 Chambers St.; felts.
- Smith, W. P., Union Sq.
- Smith, W. T. & Son, 337 Broadway; chenille curtains and rugs.
- Snedeker & Co., 116 Franklin St.; bindings, braids, ribbons and tapes for mfrs.
- Southern Cotton Mills and Commission Co., 69 Worth St.; cottons and yarns.
- Spielmann & Co., 83 Grand St.; general.
- Spies, T. H., 346 Broadway; underwear.
- Spool Cotton Co., 80 White St.; spool cottons.
- Standish Worsted Co., 715 Broadway; Frank E. Anderson.
- Steel, E. T. & Co., 66 Leonard St.; woolens and worsteds.
- Steele, Robt. P., 256 Church St.; hosiery.
- Steinam, Abraham, 162 Greene St.; converter in cotton goods.
- Stephenson & Co, 81 Grand St; woolen, mohair and worsted yarns (also at Chicago, Ill).
- Stern, Jas. & Co., 41 Greene St.; woolens and silks.
- Stern, I. L., N. Y. Life Bldg.; hosiery.
- Stevens, J. P. & Co., 23 Thomas St ; woolens.
- Stevens, Sanford & Handy, 47 Worth St.; wooleen goods.
- Stewart, John K., 51 Leonard St.; knit underwear.
- Stieglitz, M. L. & Sons, 45 Mercer St.; woolens.
- Stokes, Cromle & Co, 51 Leonard St; hosiery.
- Stoney, W. & Son, 192 W. Broadway; commission; woolens.
- Strauss, F. A. & Co., 95 Greene St.; yarns.
- Stroock, S. & Co., 65 Bleeker St.; importers of felts.
- Stursberg, W. Schell & Co. 79 Leonard St.; wooleen goods, foreign dept., dress goods.
- Sullivan Vail & Co, 331 Broadway; woolens and dress goods.
- Sutton & Co., 55 Leonard St.; hosiery and underwear.
- Syndicate Trading Co., 2 Walker St.; Mr. Adam of Buffalo, pres.; James A. Swan, vice-treas.; notions.
- Taff, Alfred, 69 Mercer St; spun silk yarns.
- Talcott, James, 108 Franklin St. American Hosiery Co, Arthur Talcott. Foreign Woolens, C. O. Benson. Domestic Woolens, David M. Look. Philadelphia Goods, Snedeker & Orchard.

- Tapscott, John S. & Co., 43 Leonard St.; commission, notions and knit goods.
- Thompson, J., 16 Greene St.; linen, twines and yarns.
- Thompson, Jas. & Co., 12 White St.; linens, and cotton goods.
- Thompson's Nephew, Samuel & Co., 142 Duane St.; jute yarns.
- Thompson, W. Baxter Co., 349 Broadway; hosiery, underwear, gloves.
- Timme, E. F. & Son, 97 Fifth Ave.; plushes, etc., agts. for Victoria plush mill, Swarthmore, Pa.
- Tingue House & Co., 84 Reade St.; plushes and felts; commission woolens.
- Todd, Murphy & Co., 69 Leonard St.; shirtings, colored and woven cotton goods.
- Townsend & Longmire, 109 Franklin St.; elastic webbing.
- Townsend & Montant, 89 Leonard St.; general; auctioneers.
- Townsend, E. M. & Co., 345 Broadway; woolens, hosiery, underwear and fancy knit goods.
- Travers Bros. Co., 107 Duane St.; twines, sash cords and nets.
- Treat & Converse, formerly Coffin, Altomus & Co., 79 Worth St.; cottons, woolens, prints, flannels, blankets and domets.
- Turner & Cliff, 91 Franklin St.; woolens.
- Turner, J. Spencer Co., 71 Worth St.; cotton duck.
- Tyler, C. C., 105 Franklin St.; bats, wadding and yarns.
- Ulmann, Bernard & Co., 109 Grand St.; hosiery and worsted.
- Unger, H. J., 115 Worth St.; mohairs and serges, also converters of cottons and woolens.
- Union Selling Co., 14 State St.; cordage.
- Urbana Woolen Mills, 53 Worth St.; E. B. Hall, agent.
- Valentine & Flagler, N. Y. Life Bldg, Broadway; shirts and drawers, Bay State Corset Co.
- Valentine & Gottsberger, 32 Howard St.; braids, etc.
- Van Keuren & Thornton Co., 117 Prince St.; cottons, white goods.
- Vaughan, L. C., 346 Broadway, Life Bldg. hosiery.
- Verder & Hardy, 486 Broadway; knit underwear, hosiery.
- Viotor, Fred & Achelis, 66-72 Leonard St.; (also branch office 88 Franklin St.); importers.
- Vogler, John G., 362 Broadway; woolen and worsted dress goods.
- Volkenburgh, P. Van & Co., 64 Worth St.; dress goods, Rodman jeans, prints, shirtings, Renfrew damasks, novelty dress goods and high art printed dress fabrics.
- Wagenar, J. W., 346 Broadway, hosiery and underwear.
- Walker Bros. & Co., Worth St.; commission.
- Wallach, Hoexter & Co., 76 Leonard St.; woolens and worsteds.
- Wallis, J., N. Y. Life Bldg.; underwear.
- Warner, M. J., 377 Broadway; linens, etc.
- Warnier, M. & Co., 91-93 Mercer St.; worsted yarns.
- Warren, B. M., 258 Church St.; cottons.
- Waters, Fred F., 105 Franklin St.; cottons and linens.
- Watson, Porter, Giles & Co., 61 Leonard St.; buttons, hosiery and woolens; importers.
- Weber, Louis & Co., 76 Franklin St.; hosiery.
- Weed & Brother, 39 White St.; linings, trimmings, cotton flannels, sheetings, etc.
- Weil Bros., 491 Broadway; woolens and duck.
- Weiller & Sons, 365 Broadway; importers.
- Weinberg, C. & Co., 105 Franklin St.; woolens.
- Weir, J. D., 78 Franklin St.; flannels, shirtings, ladies' dress linens, plain and fancy linens, curtains, suitings, and towelings.
- Weiss, A., 274 Church St.; cotton fabrics.
- Wellington, W. L., 29 Thomas St.; commission.
- Wendall & Nixon, 53 Worth St.; woolens.
- Wendell, F. L., 55 Worth St.; woolens.
- Wendell, Jacob & Co., 61 Worth St.; woolens for men's wear, serge for ladies' wear.
- Wendell, Fay & Co., 82 Worth St.; woolens.
- Wendt, Steinhauser & Co., 23 Greene St.; worsted yarns.
- Wesendonck, Lorenz & Co., 44 Leonard St.; hosiery, woolens, kid gloves and underwear.
- Wheeler, O. C. & Co., 45 Leonard St.; woolens, worsteds, dress goods and cloakings.
- Wheelwright, Eldredge & Co., 61 Worth St.; cotton goods, woolens and hosiery.
- White, G. & Co., 309 Church St.; dress goods, woolens.
- White & Lackey, 415 Broadway.
- White, Jas. F. & Co., 54 Worth St.; bur-laps, knit underwear, cotton yarn, sheetings, drills, canvas, padding, elastics and duck.
- Whiteside, James, 31 Wooster St.; cotton, worsted, jute and silk yarns.
- Whiteside, Jas. S. & Co., 57 Worth St.; blankets, cotton towels, chenille covers, quilts, and turkey red cloths, specialty of cotton crashes.
- Whitin & Collins, 112 Worth St.; unbleached and bleached muslins and cambric buntings.
- Whitman, Clarence & Co., 39 Leonard St.; printed cotton goods, Marselles quilts, dress goods, curtains, and plain cottons.

## HOOPER SONS MFG CO.,

Manufacturers and Selling Agents

**TAPES, BRAIDS, TWINES, YARNS,  
AND CORDAGE.**

426-428 Market Street, Philadelphia, Penn.

Whitman & Phelps, 260 Church St; woolens and cottons.

Whitmore, W. T, 258 Church St; woolens.  
Whittemore & Frieze, 69 Worth St.; woolens.

Wienberg, G. & Co., 103 Franklin St.; worsteds and woolens.

Wildey, Fred, 20 Lispenard St.; woolens.

Willard, J. Le B, 43 Leonard St; plain and fancy cotton goods.

Williams, John Mfg. Co., 274 Church St.; woolens and cottons.

Willimantic Linen Co., Wool Exchange.

Willis, Grinnell & Co., 46 Leonard St.; cottons.

Willington, Sears & Co., 62 Worth.

Wills, W. R., 715 Broadway; worsteds and woolens.

Wilmerding & Bisset, 78 Leonard St; hosiery, woolens and linens.

Wilmerding, Morris & Mitchell, 66 White St; general auctioneers dry goods trade.

Wilson, Geo. A., 45 Leonard St.; Turkish towels and tidies, damask quilts, dusters and crashes.

Wilson & Bradbury, 93 Franklin St; blankets, shirtings, ginghams, prints, plush robes.

Wimpfheimer, A. & Bro., 131-137 Spring St.; velvets, velveteens and corduroys.

Wimpfheimer, A. & Co., 190 Greene St.; silks.

Winndt Bros., 23 Greene St.

Winne, D. P. & Co., 338 Broadway; twines, etc.

Wolford & Dubois, Franklin St.; woolens.

Wood, William & Co, 51 Leonard St; Mt. Vernon Mills, woolens, cotton dress goods and shirtings.

Woodruff, Henry G, 66 White St; cotton goods.

Woods, Joseph W. & Son, 58 Leonard St; cottons.

Woodward, Baldwin & Co, 43 Worth St; cotton goods, cotton dress goods, plaids and linen unions.

Wright, F. H. & Co., 715 Broadway; woolens.

Wright, Wm. E. & Co., 351 Broadway; hosiery and underwear.

Wright & Graham, 15 White St.; cottons, woolens, tapes, linens, etc.

Yelland, Wm. & Co., 51 Leonard St.; cottons.

Young, Chas. B. & Co., Broadway and 17th St., Hartford Building; upholstery goods.

Youngman, W. L., 79 Worth St.; chevionts and blankets.

### New Orleans.

Bowling, N, 434 Common St.

Charnock, Henry, 629 Gravier St.; importer.

Dickson, W. H., 518 Custom House St.; domestic cottons and woolens, matings.

Langtry, G., People's Bank Bldg.

May & Ellis, 209 Chartres St.

Walker Bros. & Co, 301 Magazine St.

### Philadelphia.

Abbott, Wm. G., 242 Chestnut St.; yarns.

Adams, W. I. & Co., 707 Market St.; woolens.

Aiman, Richard N., 578 Bourse; dress goods.

American Cotton Yarn Exchange, 240 Chestnut St.

American Thread Co., 1019 Filbert St.; (see New York.)

American Woolen Co., 701-05 Bourse.

Argo Mills, 318 Merchant & Marine Bldg.

Bacon & Co., 230 Chestnut St.; commission. (see New York.)

Baily, Joshua L. & Co., 15 Bank St.; cottons, dress goods, etc. (see New York.)

Ball, Thomas H, 236 Chestnut St; Worsteds yarns.

Beaumont, E. A, Bourse, 565 Market St; cottons.

Bliss, Fabyan & Co., City Trust Bldg.; prints, hosiery, etc. (see New York.)

Botany Worsteds Mills, 322 Merchant & Marine Bldg.

Blythe, Richard A, 114 Chestnut St; cotton yarns.

Brown, I. H, 30 N. Seventh St; hosiery.

Brown, M. Sons & Co., 35 S. 3d St.; commission. (see New York.)

Brown, Wm. C., 230 Church St.; linings.

Buckingham, Paulson & Co., 118 Chestnut St.; cotton yarns. (see New York.)

Burnley, John B., 41 Strawberry St.; carpet yarns, waste.

Butler, B. F, 102 S. 12th St.

Caldwell, David S, Stephen Girard Bldg; cottons and linens.

Callaghan, M. J., 226 Church St.; cotton goods.

Cameron, A. J. & Co., 37 S. 3d St.; cotton, woolen and worsted yarns.

Campion, Richard, 17 Bank St; cotton, woolen and worsted yarns.

Carson, J. W. B; hosiery, sweaters, underwear, etc.

Catlin & Co., 206 Chestnut St.; piece goods, yarns. (see New York.)

Chapin, Geo. W., 229 Church St.; tapes, braids, yarns, etc.

Cheney Bros., 929 Chestnut St.; silks.

Coffin, Altemus & Co., 504 Bourse; commission.

Coleman & Bros, 212 Chestnut St; worsted yarns.

## R. HARRY HOLLIS, Direct Selling Agent

For Turkish Towels, Hosiery, Underwear, Knit Goods and Hammocks.

Representing the best mills in the country.

Room 368, Bourse,

PHILA, PA.

- Colesberry, H. W., 927 Chestnut St.
- Collins, W. C. & Co., 312 Cherry St.; upholstery goods, curtains, etc.
- Conrad & West, 11 Bank St.; converters of cotton goods, and importers of linens.
- Converse, Stanton & Co., 618 Chestnut St.; commission. (See New York.)
- Cooke, James W. & Co., 239 Chestnut St.; cottons, woolens and prints.
- Coral Mfg. Co., 692 Bourse; yarns.
- Cope, F. H., 468 Bourse; yarns.
- Corbett, John & Sons, 32 Bank St.; cotton, woolen, worsted and silk yarns.
- Critten, Clift & Co., 1020 Chestnut St.; underwear. (See New York.)
- Croll, Albert I., 241 Chestnut St.; cotton yarns.
- Cromwell Bros., 1013 Filbert St.; cotton white goods.
- Daniel, H. M., 511 Bourse; yarns.
- Danielson, Wm. H., 4029 Walnut St.
- Davis, H. J., 603 Chestnut St.
- D'Oliver, Wm. & Co., 126 Chestnut St.; cotton also cotton, woolen and worsted yarns.
- Dumee, Sons & Co., 402 Provident Bldg.; cotton, also cotton yarns.
- Eddy & Street, 218 Chestnut St.; cotton, woolen, worsted and silk yarns. (head office Providence, R. I.)
- Ellis, D. W. C. & Co., 246 Chestnut st.; cotton goods.
- Emlen, Geo. W., 240 Chestnut St.; dress goods.
- Evans, Dorrance, 131 North 9th St.; cottons.
- Evans, Smith & Co., 132 Chestnut St.; yarns.
- Farnum, John & Co., 235 Chestnut St.; ticking.
- Farren, H. J., 5 Bank St.; hosiery.
- Fawcett, Hugh, 585 Philadelphia Bourse; yarn. (See New York.)
- Fleming, Geo. M., 1619 No. Sixteenth St.; yarns.
- Friedberger Mfg. Co., Fisher Lane, Germantown; silk yarns and edgings, laces.
- Frier & Co., 692 Bourse; yarns.
- Gleason, Edwin P. & Son, 1019 Filbert St.; commission.
- Gratz, Edward & Co., 240 Chestnut St.; commission.
- Griswold Worsteds Co., 227 Chestnut St.; yarns.
- Grushlaw & Robbins, 12 So. 4th St.
- Hagy, J. M., 425 Bourse; waste.
- Harding, Whitman & Co., Merchants & Marine Bldg (See Boston.)
- Hartford Carpet Corporation, The, 606 Bourse.
- Hird, Samuel, 241 Chestnut St.; woolen, worsted and merino yarns.
- Hoffman, Corr & Co., 415 Market and 219 Church St.; cotton yarns, etc.
- Hollis, R. H., Bourse; hosiery.
- Hooper's Sons Manufacturing Co. (agts. for Newman Cotton Mills and Boston Thread and Twine Co.), 428 Market St.; cotton yarns.
- Huggard, John, 36 Strawberry St.; linens.
- Hutchinson, Pemberton, S. & Co., 112 Chestnut St.; checks, gingham, etc.
- Hyde, A. G. & Sons, 603 Chestnut St. (see New York.)
- Hyde, Edward S., 223 Chestnut St.; cotton yarns.
- Jeffries, Thos. J., 27 Bank St.; upholstery goods.
- Jennings, E. B., 208 Chestnut St.
- Joy, Langdon, & Co., 603 Chestnut St.; commission. (See New York.)
- Juilliard, A. D. & Co., 235 Chestnut St.; cottons, woolens and silks. (See New York.)
- Kenworthy, T. & Bro., 111 Church St.; wool, also cotton, woolen and worsted yarns.
- King, Edward D., 5 Strawberry St.
- King, Hillman & Gill, 6 Strawberry St.; commission.
- Kremer & Strubing, 626 Chestnut St.; commission. (See New York.)
- Kunhardt & Allen, 576 Bourse. (See New York.)
- LaLanne, Frank D. & Co., 214 Chestnut St.; woolens.
- Lamson, Roger & Co., 5 Bank St.; hosiery. (See New York.)
- Lane, J. H. & Co., 228 Chestnut St.; cottons. (See New York.)
- Lawrence & Co., 615 Chestnut St.; commission.
- Legge, Percy A., 134 Chestnut St.; woolen, worsted and silk yarns.
- Lelper, Chas. L., 240 Chestnut St.; cotton, woolen and worsted yarns.
- Leob, Oscar D., 226 Chestnut St.
- Lewis, H. & W. H., 238 Chestnut St.; cottons and woolens. (See New York.)
- Lings, G. S. & Co., 393 Philadelphia Bourse; cotton yarns. (See New York.)
- Lippincott, A. G. & Co., 424 Market St.
- Love, Alfred H. & Co., 219 Chestnut St.; cottons, woolens, etc.
- Malcolm Mills Co., Orchard ab. Church St.; yarns.
- McCloskey, J. J., 34 N. Front St.; wool waste, also carpet yarns.
- McCloud, Chas. M. & Co., 229 Chestnut St.; cotton, woolen and silk yarns.
- McDonnell, Stout & Co., 1011 Filbert St.; importers of silks and satins.
- Mitchell, J. E. & Co., 124 Chestnut St.; cotton yarns.
- Moore, C. & Co., 500 Market St.; worsted yarns, tapes, cords, braids, etc.
- Moss, Taylor & Co., 927 Chestnut St.; commission. (See New York.)
- Moyer's, M. Son, 213 Church St.
- Neall, Geo. M., 20 Strawberry St.; jute and linen yarns.
- Newcomb, 633 Bourse; yarns.
- New England Cotton Yarn Co., 213 Chestnut St. (See Boston & New York.)
- O'Neil, Chas., 57 No. Front St.; yarns, wool waste.
- Penny, G. F., 134 Chestnut St.; jute yarns.
- Penn Yarn Co., 320 Merchants & Marine Bldg.
- Ransohoff, E. & Son, 11 Strawberry St.; turkish towels, etc.
- Read, Wm. F., 213 Chestnut St.; silk warps; worsteds.
- Robb, Daniel & Co., 219 Chestnut St.; cotton, woolen and worsted yarns.
- Roberson, W. K., 313 Market St.; white goods.

Robertson, James & Co., 9 Bank St.; knit goods.

Rosenbaum, H., 414 Arch St.; hosiery.

Schell, Taylor & Longstreth, 230 Chestnut St.; cotton yarns.

Scully, Jos. W., 215 Chestnut St.; woolen and worsted yarns; broker.

Seffarlan, Jos. A., 427 Market St.; carpet yarns.

Sharples, W. M. & F. W., 123 Chestnut St.; cotton yarns.

Sheble, F. J., 113 Chestnut St.; carpet yarn.

Siebrecht, Geo. & Co., 919 Chestnut St.; silks and fancy goods.

Simpson, William, Sons & Co., 130 Chestnut St.; commission.

Sloan, N. P. & Co., 241 Chestnut St.; cottons.

Southern Cotton Yarn Exchange, 304 Merchants & Marine Bldg.

Southwick Mills, 624 Bourse; yarns.

Steel, Edward T. & Co., 24 Bank St.; worsted goods.

Steinmetz, Geo. W., 19 Bank St.; commission.

Stephenson & Co., 240 Chestnut St.; woolen, worsted and mohair yarns. (See New York.)

Stevens, C. E. & H. S., 58 South 3rd St.

Stokes, Cromie & Co., 235 Chestnut St.; knit goods, hosiery, etc.

Stoyle, Wilson H., 134 Chestnut St.; yarns.

Tatterfield & Co., 33 Letitia St.; wool, also woolen and worsted yarns.

Taylor Bros., 240 Chestnut St.; yarns.

Thomas & Houston, Provident Building; cotton yarns.

Thompson, Foust & Co, 11 Bank St.; hosiery, knit goods, etc.

Thompson, Henry K, 9 Strawberry St.; cotton and woolen yarns.

Thompson, Wm. H., 240 Chestnut St.; cotton yarns.

Tinkler & Co., 20 N. 5th St.; cotton & woolen yarns.

Townsend, E. M., 1107 Market St.; hosiery and underwear.

Treat & Converse, 503 Bourse; commission. (See New York.)

Turner, A. J., 567 Bourse; cotton goods.

Vogler, John G., 622 Chestnut and 2633 N. Bodine Sts.; dress goods. (see New York.)

Vogles, J. W., 569 Bourse; cotton bats.

Wallace, J. C., 39 South 3rd St.; cotton, woolen and worsted yarns.

Webb, Chas. J. & Co., 116 Chestnut St.; yarns and wool.

Wendell, Fay & Co., 939 Market St.; woolens. (See New York.)

Wheelwright, Eldredge & Co., 927 Chestnut St.; commission. (See New York.)

White, Jas. F. & Co., 229 Chestnut St.; cotton and woolen yarns. (See New York.)

Willey, J. H., 235 N. Water St.; wool, also woolen and mohair yarns.

Wilson & Bradbury, 217 Chestnut St. (see New York.)

Wood, Wm. & Co., 572 Bourse.

Young & Armitage, 1200 Chestnut St.; towels, table covers, etc.

---

### Pittsburg.

Brown, Thos. H., 708 Penn Ave.; hosiery and underwear.

Potts, O. A. Co., McCance Block; hosiery and underwear.

Given, John M.; broker. (See New York.)

Samuels, I. A. & Co., Penn Ave.; hosiery, underwear, sweaters, etc.

Swearingen, C. H., 9th and Liberty Sts.; hosiery, underwear and knit goods.

---

### Providence, R. I.

Broadhead, Firth, 937 Banigan Bldg., Eddy & Street; cotton, woolen, worsted and silk yarns. (also Phila.)

Howland Craft, Sons & Co.; worsted yarns.

Tillinghast, Stiles Co., The Industrial Trust Bldg.; cotton and worsted yarns. (New York office 507 Wool Exchange Bldg.)

---

### San Francisco.

Ach, Julius, 11 Sansome St.; linens and hosiery.

Drews, H., room 101 Flora Bldg.; fine yarns and art goods.

Hennessy & Seavey, 14 Sansome St.; hosiery, pants and shirts.

Marks, Jacob, 330 Market St.; hosiery, underwear, towels, etc.

McNaughton, W. A., room 27 Flora Bldg.; upholstery, drapery and curtains.

Ottis, Wm. E., Phelan Building; hosiery and underwear.

Price, W. T., 120 Sutter St.; hosiery, underwear, sweaters, woolens and fancy goods.

Sanborn, G. O., 12 Mt. Gomery St.; sweaters, etc.

Schlichten, G. W., 14 Sansome St.

Thieben, Jos. & Co., 220 Sutter St.; novelties and fancy goods.

Zuckermann, M. W., 14 Sansome St.; fancy goods.

# W. T. PRICE, Manufacturers' Selling Agent

HOSIERY, UNDERWEAR,  
WOOLEN AND COTTON PIECE GOODS.

Connections in Orient and Pacific Islands.  
Reliable Mill Accounts Solicited.

220 SUTTER STREET,  
SAN FRANCISCO, CAL.

**St. Louis.**

Anderson, Geo. F., 703-05 Lucas Ave.; notions and hosiery.  
 Bateson, Horace, 805 Lucas Ave.  
 Canard, J. D. & Son, 345 Century Bldg.; cottons. (also Baltimore.)  
 Coyle & Sargent, 1121-23 Washington Ave.; linens, braids, silks.  
 Glaser, Julius & Co., 44 N. 11th St.  
 Hanenkamp, R. J., Jr., Columbia Bldg.  
 Hazelton, H., 408 Merinod and Jacquard Bldg.; commission.  
 Hewet, James H., 703 Lucas Ave.; dry goods specialties.  
 Jacobus, J. R., 508 Washington Ave.; commission.  
 Jones, Robt. McK. & Co., 1120 St. Charles st.; commission.  
 Lewis, O. J., Mercantile Co., 616 N. 8th St.; commission.  
 Lippelt, G. H. & Co., 803 Lucas Ave.; rubber goods.  
 Nason, J. C. & Co., 715 Locust Ave.; woolens and silk.

Perkins, Robert F., 703 Lucas Ave.; specialties.  
 Putnam, Hooker & Co., 318 No. Eighth St.; commission. (See Cincinnati and New York.)  
 Sischer-Hayne Dry Goods Com. Co., 711 Lucas Ave.; velveteen bindings.  
 Simpson, Wm., Sons Co., Century Bldg. (see New York.)  
 Skinner, White & Co., 713 Lucas Ave.; commission.  
 Sohus, Frank N., 715 Locust St.; silk, wool, cotton piece goods.  
 Tivy, Geo. S. & Co., 911 Locust St.; cottons and woolens.  
 Volkenburgh, P. Van, & Co., Columbia Bldg. (see New York.)  
 Wangellin E. H. & Co., 703 Lucas Ave.; notions; velveteen bindings.  
 Warren, New, 911 Locust St.; cotton, ducks, twines.

**Savannah, Ga.**

John Flaunery Company; cottons.

**MANUFACTURING CLOTHIERS.**

In the principal cities, buying from first hands.

**Albany.**

Babcock & Shannon Co., Swan and Jay Sts.; men's clothing, shirts, underwear, mackintoshes, rubber coats.  
 Buyers: A. W. Shannon, C. N. Gilbert.  
 Craft, Chas. G. & Co.  
 Joseph Bros.  
 Levi, Edward & Co, 2 Grand St.

**Baltimore.**

Ambach Bros. & Co, 17 Hopkins Pl.  
 Buyer: M. Ambach.  
 New York office, 751 Broadway.  
 American Pants Mfg. Co., 221 W. Baltimore St.  
 Baer, B. B. & Co., 31 W. Baltimore St.; pants.  
 Baker, Tobias & Co., 207 W. Baltimore St.  
 Baltimore Bargain House, 204 W. Baltimore St.  
 Baltimore Clothing Mfg. Co., 13 W. German St.  
 Baltimore Pants Mfg. Co, 527 W. Baltimore St.  
 Bank, S. & Co., 37 W. Baltimore St.; pants.  
 Benedict Bros., 106-108 Hopkins Pl.; overalls.  
 Bernstein, Cohen & Co., 325 W. German St.; general line.  
 Buyer: Phillip Bernstein.  
 Blum, M. I. & Bro., 27 Hanover St.; pants.  
 Brafman Bros. & Co., 217 W. Baltimore St.; general line.  
 Buyer: Mr. J. Brafman.  
 Burger, Chas. & Co., 371 Hopkins Pl.  
 Burgunder Bros. & Co, 112 W. Baltimore St.; general line.

Burk, Fried & Co., 617 E. Baltimore St.; general line.  
 Catzen, Wolf & Co., 2015 Callow Ave.  
 Coblens, Gilbert & Co., 7 So. Howard St.  
 Cohen & Hartz, 102 W. Baltimore St.  
 Cohn, Alexander & Bro, 421 W. Baltimore St.  
 Cohn, Adolph & Son, 947 Madison Ave.  
 Croekin & Co., 211 W. Baltimore St.; pants.  
 Elseman Bros, 213 W. German St; general line.  
 Buyers: Each member of firm.  
 Eisener & Krulewitch, 13 W. German St.; cheap grades.  
 Epstein, Jacob & Co., 216 W. Baltimore St.; pants.  
 Feldman & Racusin, 316 W. Baltimore St.  
 Fenzel, Henry J., 1536 Penna Ave.; pants.  
 Fine, Israel & Son, 200 So. Sharp St.; general line.  
 Fine & Schuchart, 103 W. German St.  
 Frank, E. & Bro., 22 W. Pratt St.  
 Buyers: Both members.  
 Franklin Overall Mfg. Co., 113 N. Gay St.; overalls.  
 Fried & Co., 305 N. Gay St.  
 Friedmann, M. & Sons, 27 W. Baltimore St.; boys' and children's clothing.  
 Buyer: Mr. Sol. Friedmann.  
 Ginsberg, S. & Co., 26 Hopkins Place.  
 Glassner, Snyder & Co., 1111 E. Pratt St.; general line.  
 Goldheim & Son, Samuel, 519 E. Baltimore St.; general line.  
 Goodman, Levin & Co., 10 Hanover St.  
 Greenblatt, Jonas, 832 E. Pratt St.  
 Greif, L. & Bro, 107 W. Baltimore St.; general line.  
 Buyer: Simon Greif.  
 New York office, 648 Broadway.  
 Grinsfelder, D. J. & Co, 414 W. Baltimore St.; men's fine clothing.



- Buyer: D. J. Grinsfelder.
- Hamburger Bros. & Co, 16 So. Eutaw St; general line.  
Buyer: L. Hamburger.  
New York office, 785 Broadway.
- Hamburger Mfg. Co., 16 S. Paca St.; children's wear.  
Buyer: Sam Hamburger.
- Hamburger, I. & Sons, 222 W. Baltimore St; general line.  
Buyer: Mr. Hamburger.
- Harris, Levy & Ginsberg, 527 W. Baltimore St.
- Harzberg, J. & Co., 32 W. Baltimore St.; general line.  
Buyer: Mr. Fleisher.
- Hoff, A. & Son, 40 S. Howard St.
- Huchberger, Jacob & Co, 423 W. Baltimore St; general line.  
Buyer: J. Huchberger.
- Jacobson & Baker, 219 W. Baltimore St.; pants.
- Kahn, Moses, 447 No. Gay St.
- Kahn, P. & Co., N. Gray St. near Bridge.
- Kahn, Samuel, 225 No. Gay St.
- Katz, K. & Sons, 309 E. Baltimore St.
- Kaufman, E. & Sons, 5 S. Liberty St.; boys' clothing.
- Kuff & Levitan, 304 West Baltimore St.
- Lauchheimer, M. H. & Sons, Paca and German Sts; general line.  
Buyer: J. Lauchheimer.
- Lehman, Lewis & Co., 428 S. Broadway.  
Buyer: Mr. Lehman.
- Levin, P. & Co., 36 W. Baltimore St.
- Levy Bro. & Edlavitch, 602 E. Baltimore St.
- Levy & Leventhal, 104 W. Baltimore St.; pants.
- Levy, Paul S. & Co, 405 W. Baltimore St; general line.  
Buyer: P. S. Levy.
- Likes, Berwanger & Co., 10-12 East Baltimore St; men's wear.  
Buyer: Mr. Likes.
- Lowman, S. & Co, 21 Hopkins Pl; general line.  
Buyer: S. Lowman.
- Macht Bros. & Macht, 12 Hanover St.
- Mann, J. & Son, 24 Hopkins Pl.
- Mayer, L. & Co., 308 W. Baltimore St.
- Miller, S. F. & A. F. Co., 39 Hopkins Place.  
Buyer: Mr. Schloss.
- Oehm & Co., 5 W. Baltimore St.; general line.  
Buyer: Mr. Oehm.
- Oppenheimer, Henry, & Co., 113 W. German St.; general line.  
Buyer: Mr. Oppenheimer.
- Reinhard, Meyer, & Co., 327 W. Baltimore St.; general line.
- Ring, M. & Son, 211 W. Baltimore St; general line.  
Buyer: Louis Ring.
- Rosenstock, H. S. & Co., 522 W. Baltimore St.; general line.
- Samuels, A. & Co., 108 W. Baltimore St.
- Schless Bros. & Co., 500 Baltimore St.; general line.  
Buyer: Nathan Schloss.  
New York office, 764 Broadway.
- Schloss, Wm. & Sons, 416 South Broadway; general line.
- Schoeneman, J., 319 W. Baltimore St.; pants.  
Buyer: J. Schoeneman.
- Silverman, Harris, 6 N. Liberty St.
- Singer, I. & Son, 46 W. Baltimore St.; general line.
- Sonneborn, Henry & Co., 12 Eutaw St.; general line.  
Buyers: Henry and Sgm. B. Sonneborn.  
New York office, 743 Broadway;  
Chicago office, 210 Franklin St.;  
St. Louis office, Planters' Hotel.
- Stein, M. & Co., 424 E. Baltimore St.
- Stern, A. & Co., 28 S. Paca; cloaks.
- Strauss, A. J. & Co, 407 W. Baltimore St; pants.  
Buyer: Abe Strauss.
- Strouse & Bros, Lombard and Paca Sts; general line.  
Buyers: I. and E. Strouse.  
New York office, 733-735 Broadway.
- Strouss Mfg. Co., 46 Baltimore St.; men's and youth's pants.  
Buyer: T. Strauss.
- Thalheimer Bros., 113 W. Baltimore St.
- Weinberg, Max & Co., 205 W. Baltimore St; general line.  
Buyer: Max Weinberg.
- Wurtzburger, H. & Sons, 351 N. Gay St.

### Boston.

- Andrews, Mark & Co., 54 Chauncey St.  
Buyer: Mark Andrews.
- Blaisdell & Gonnam, 69 Chauncey St.; shirts.  
Buyers: B. W. Gonnam, G. H. Downing.
- Burton-Pierce Co., The, 32 Chauncey St.  
Buyers: Elbridge P. Jones, Alfred Pierce.
- Cohen, A. & Co., 35 Kingston St.
- Cohen, Israel & Co, 87 Summer St.  
Buyer: Israel Cohen.
- Davies, Payson & Co., 69 Chauncey St.
- Dean, M. & Co., 121 Summer St.
- Fowle & Pearson, 65 Bedford St.  
Buyer: L. Fowle.
- Freed, A. P. & Co, 65 Bedford St.  
Buyer: A. P. Freed.
- Freeland, Loomis Co, 651 Washington St.  
Buyer: C. R. Talbot.
- Hodgdon, Anderson & Merry, 33 Otis St.  
Buyers: G. P. Hodgdon and Arthur B. Anderson.
- Holzman Bros., 87 Summer St.
- Kirschbaum, Ab. & Co., Boylston Bldg.; D. L. Brunnelle, agent.
- Klein, J. & Co., 15 Chauncey St.
- Levy, G. H. & Co., 37 Otis St.  
Buyer: G. H. Levy.
- Lincoln, Sheinwald, Planding & Hemenway, 89 Summer St.; wholesale clothiers.
- Loomis, S. W. & Co., 146 Lincoln St.  
Buyer: S. W. Loomis.
- Macullar, Parker Company, 400 Washington St.  
Buyer: Chas. W. Parker.
- Miner & Beal, 63 Summer St.  
Buyers: Leander Beal, H. K. Dunton and A. F. Cooke. (assigned.)
- Morse, Leopold, & Co, 131 Washington St.
- Myers & Andrews, 36 Otis St.  
Buyer: S. A. Myers.
- Oak Hall Clothing Co., 95-105 Washington St.  
Buyer: F. R. Tackaberry.

Peavy, J. & Bros., 38 Summer St.  
Peerless Bicycle Clothing Co, 79 Summer St.  
Buyers: M. & S. Birnbaum.  
Rhodes & Ripley Clothing Co, 72 Lincoln St.  
Buyer: Ebed L. Ripley.  
Rice, Sayward & Whitten, 101 Arch St.  
Buyer: C. H. Whitten.  
Russell, Snow & Davis Co, 28 Summer St.  
H. G. Hartshorne, pres; Billings Smith, treas.  
Ryan & McMahon, 93 Summer St.  
Shaw Bros. & Co., 76 Summer St.; shirts.  
Buyer: Arthur J. Shaw.  
Shuman, A. & Co., 440 Washington St.  
Buyers: Samuel Shuman, Sidney Shuman and E. A. Shuman.  
Silverman, M., 155 Richmond St.  
Buyer: M. Silverman.  
Smith, Chase & Cutting, 79 Bedford St.  
Buyer: E. R. Smith.  
Smith, John O., Co., 100 Chauncy St.  
Buyer: John O. Smith.  
Smith, Sherman & Co., 100 Chauncy St.  
Buyer: George S. Smith.  
Spitz Bros. & Mork, 65 Summer St.  
Buyer: Henry B. Spitz.  
Standard Clothing Co., 395-403 Washington St.; Geo. N. Talbot, pres.  
Strecker & Nathanson, 15 Chauncy St.  
Buyer: M. Strecker.  
Thompson & Snow Co., 34 Chauncy St.  
Wilson, Geo. & Co., 131 Kingston St.  
Union Mfg. Co., 24 Chauncy St., pants.

### Brooklyn.

Barnard & Co., Geo. (Sportsmen's Clo.), Pacific St. and 6th Ave.  
Brown, B., 565 Fulton St.; general line.  
Buyer: B. Brown.  
Cooper, T. S. & Sons, 107-109 Broadway; men's boys' and children's.  
Buyers: T. S. Cooper, Edward Cooper.  
Gomers' Chas. Sons, Broadway and Ewen St.; men's, boys' and children's.  
Buyer: G. Gomers.  
Heisman, Heyman, 158 Grand St.; general line.  
Buyer: H. Heisman.  
Lynd, Robt. M., 33 Nevins St.; coats and gowns.  
Rosenberg, M. & Son, 481 Fulton St.  
Smith, Gray & Co., 542 Fulton St.; men's, boys' and children's.  
Buyers: Mr. Randolph, Mr. Spence.

### Buffalo.

Bean, W. A., 16 Ellicott St.; overalls.  
Beyer Bros., 106 Genesee St.; shirts, overalls and pants.  
Buyer: Mr. Beyer.  
Brock, Henry J. & Co., 36 Pearl St.; general line.  
Cohen & Sinai, 60 Pearl St.; tailor's trimmings.  
Buyer: Samuel Sinai.  
Cohn & Co, 187 Washington St.  
Cloth and trimmings, I. Cohn.  
Pants and overalls, E. Riesenfeld.  
Cohn, Frank & Co., 38 Pearl St.  
Desbecker-Block Tailoring Co., The, 68-72 Seneca St.  
Woolens: H. W. Block.

LaDue & Tate Mfg. Co., 74 Exchange St.; pants.  
Lepper & Ellwood, 251-57 Main St.; pants, shirts, overalls.  
Buyer: Mr. Lepper.  
Levi, Julius, 226 Washington St.; pants and overalls.  
Lewin, B. & Co., 40 Pearl St.; suits.  
Masten, W. I. & Co., 185 Washington St.; overalls and pants.  
Buyer: W. I. Masten.  
Niagara Overall & Pants Co., 192 Seneca St.; pants and overalls.  
Warner Bros. & Co., 30 Pearl St.; Clothing Exchange.  
Woolens, K. Greenburg.  
Trimmings, E. Warner.  
New York office, 74 Leonard St.  
Wile, M. & Co., 48 Pearl St.; general line.  
Buyer: M. Wile.  
Wile Bros. & Weill, Ellicott and Carroll Sts.; men's, boys' and children's clothing.  
Buyer: H. Wile.

### Chicago.

Abt, L. & Sons, 218-220 Market St.; general line.  
Buyer: S. L. Abt.  
New York office, 102 Franklin St.  
Alexander & Cohn, 192-194 Madison St.  
Buyer: J. Alexander.  
Alshuler, Chas., Mfg. Co., 237 Fifth Ave.  
Becker, Mayer & Co., 216-218 Van Buren St.; boys' clothing.  
Buyer: Jos. Mayer.  
Berkson & Kallman, 231 Jackson Boul.; men's clothing.  
Buyer: Firm.  
Bernstein, Cohen & Co., 122-24 Market St.; shirts and overalls.  
Blum Bros., 155-159 Market St.; sweaters.  
Buyer: Mr. Blum.  
Blumberg Mfg. Co., 116 Market St.; boys' and ladies' waists, children's cloaks.  
Buyer: J. J. Blumberg.  
Born, M. & Co., 337 Franklin St.  
Buyer: M. Born.  
Brown, Chas. & Co., 189 Market St.; men's clothing.  
Buyer: Chas. Brown.  
Cahn, Wampold & Co., 255 Jackson St.; general line.  
Buyer: F. Cahn.  
Calumet Woolen Co., 195 Market St.; importers and jobbers.  
Buyer: Leo Polocheck.  
Chicago Tailoring Co., 187 5th Ave.  
Buyers: Strauss & Maack.  
Clement, Bane & Co., 200 Monroe St.  
New York office, 10 White St.  
Cohn, H. & Son, 156 Market St.; general line.  
Buyers: H. Cohn and C. A. Levy.  
Cohn, J. W. & Co., 256 Madison St.  
Cohn, Morris, 225 Market St.  
Connor, Geo. H. & Co., 275 Franklin St.; duck clothing.  
Conyne Mfg. Co., 260-262 5th Ave.; general line.  
Buyer: Mr. Conyne.  
Daube, Cohn & Co., 248 Market St.; boys' clothing.  
Buyer: D. A. Cohn.  
Daus, F., Jr., 172 Market St.

- Detmer Woolen Co, The Williams Building, 200 Monroe St.  
Buyer: J. F. Detmer.  
N. Y. office, 225 Fourth Ave.
- Edelman, H., 176 W. 12th St.; shirts.
- Ederheimer, Stein & Co., 212 Market St.; boys' clothing.  
Buyers: M. Ederheimer, D. B. Falter.  
New York office, 52 Franklin St.
- Eichengreen, Schreiber & Co.; young men's and juvenile clothing, also smoking jackets.  
Buyer: S. Schreiber.  
New York office, 714 Broadway.
- Eisinger, Dessauer & Co., 164-166 Market St.; general line.  
Buyer: E. Eisinger.
- Ettelson, Julius & Co., 131 Market St.
- Fass Bros., 144 S. Clarke St.
- Finkelstein, L. & Co., 98 Market St.
- Fox & Strauss, 186-188 Fifth Ave.
- Franks, H. J. & Co., 199-201 Madison St.; general line.  
Buyer: J. M. Rosenbach.
- Friedlander, D., 21 N. Greene St.
- Gatzert, J. L. & Co., 220 Adams St.; merchant tailors.
- Goodmann, Milton & Co., 240 Franklin St.; overalls.
- Gorman & Groves, 234 5th Ave.; woolens and dress goods.  
Woolens, J. C. Gorman.  
Dress goods, F. W. Groves.
- Great Northern Clothing Co., 247 Clark St.
- Harper, John, 231 Monroe St.; coats.
- Hart Bros., 242-43 Adams St.; shirts, men's goods.  
Buyers: H. N. Hart, N. J. Schmaltz.  
New York office, 38 Thomas St.
- Hart, Schaffner & Marx, Market and Van Buren Sts; woolens, general line.  
Buyers: Harry Hart, Max Hart.  
New York office, 727 Broadway.
- Heavenrich Bros., 208-14 Van Buren St.; men's and boys' clothing.  
Buyers: Walter and John A. Heavenrich.  
New York office, 702 Broadway.
- Hefter, Livingston & Co., 155 Market St.; boys' clothing and woolens.  
Buyers: C. Hefter, M. Hefter.  
New York office, 710 Broadway.
- Herman, S. J. & Co., 237 Fifth Ave.; shirts.
- Hirsh, Wickwire & Parks, 160-162 Market St.; general line woolens.  
Buyers: J. Hirsch, D. S. Hirsch.
- Hoeker, Corsier & Mitchel, 234 Franklin St.; overalls and pants.
- Hutchens, Howe & Withington, 236 Monroe St.; fine negligee shirts.  
Buyer: O. B. Hutchens.
- International Tailoring Co., 211 E. Jackson Boul.
- Jelonak, J. & Son, 149-51 Market St.; clothing specialties.
- Joseph, Carl & Co., 136 Fifth Ave.  
Buyer: Mr. Joseph.
- Judah Bros., 131 Market St.
- Kahn, Felix & Co., 195 Market St.; general line.
- Kauffman, Fred, 156 Market St.; general line.
- Kaufman, Chas. & Bros., 202 Market St.; general line.  
Buyer: C. Kaufman.
- Kohn Bros., Market St. and Jackson Boul.; woolens, tailors' trimmings.  
Buyer: A. W. Kohn.  
New York office, 66 Leonard St.
- Kramer & Co. (Marquette Custom Garment Co.), 185 Dearborn St.; general line.
- Kuh, Nathan & Fischer Co, Franklin and Van Buren Sts; general line.  
Buyers: E. Buxbaum, E. J. Stransky.  
New York office, 74 Leonard St.
- Kuppenheimer, B. & Co., 246 Franklin St. General line, Jonas Kuppenheimer. Trimmings, L. Kuppenheimer.
- Lamm & Co., Fifth Ave. and Van Buren St.; general line.  
Buyer: Mr. A. Lamm.
- Landrum, T. J. & Co., 172 Market St.
- Leopold, Solomon & Eisendrath, 234-36 Market St.
- Leshner, J. H. & Co., 185 Madison St.; woolens and tailor trimmings; J. H. Leshner, John L. Bobo.
- Levy, S. & Co; cloth.  
Buyer: I. Berkenfield.
- Lewin, A. & Son, 234 Market St.; pants and shirts.
- Lewis & Co., 98 Market St.
- Lindenthal & Goodman, 225 Market St.; boys' clothing.  
Buyer: H. M. Lindenthal.
- Loeb, L. & Sons, 246 Market St.; pants; Herman Loeb.
- Loeb, H. & Co., 246 Market St., formerly of Cincinnati; pants.
- Loewenstein, L. & Sons, 196-200 Market St.; general line.  
Buyer: S. Loewenstein.  
New York office, 74 Leonard St.
- Longenecker, Evans & Co., 246-50 Market St.; white duck clothing.  
Buyer: Firm.
- Mandl, Bernard, 153 Market St.; gymnasium and athletic clothing.  
Buyer: B. Mandl.
- Marcus, Solms & Son, 220 Madison St. Woolens, Solms Marcus.
- Marks, H. M., & Co., 200 Market St.
- Meyer & Co., 200 Market St.  
Buyer: Henry X. Strauss.
- Michaels, Stern & Co., 237 Fifth Ave.
- Miller, J. G. & Co., 254 Jackson Boul.; men's clothing.  
Buyer: J. G. Miller.
- Morgenthau Bros, 202-204 Market St; boys' and children's.  
Buyer: M. L. Morgenthau.
- Morris & Goldschmidt, 773 So. Halsted St.
- Murphy & Co., 103 Clark St.
- Oberndorf, M. L. & Co., 202-204 Van Buren St.
- Oppenheim & Finkelstein, 523 Halsted St.; boys' and children's clothing.
- Parnass, Max, 242 Madison St.; jobber.  
Buyer: M. Parnass.
- Paulet, E. A. & Co., 233 Jackson Boulevard.
- Peck, W. S. & Co., Van Buren and Market St.; general line. (see Syracuse, N. Y.)
- Pfaelzer, David N. & Co., 221 Market St.; boys' clothing.  
General line, D. M. Pfaelzer.
- Price, Ed V., 189 Van Buren St.
- Progress Tailoring Co., The, 300 Monroe St.  
Buyer: Otto Bair.
- Raphael & Harris, 219 Van Buren St.

- Reinach, Ullman & Co., 264 Fifth Ave.  
Buyer: J. Frohlich.
- Reliance Mfg. Co., 240 Franklin St.;  
workingsmen's clothing, overalls,  
shirts, pants.
- Rose, A. B. & Co., 45 Clark St.
- Rose, Edward, & Co., 200 Market St.;  
clothing.  
Buyer: W. R. Rose.
- Rosenblatt, Morris, 98 Market St.
- Rosenwald & Weil, 178 Market St.; spe-  
cialties.  
Buyer: M. S. Rosenwald.  
New York office, 729 Broadway.
- Rothschild, Felix & Co., 201 Market St.
- Rotshchild, E. & Co., 248 Jackson Boul.  
Buyer: Gus. Hanauer.
- Royal Tailors, The, Michigan Ave. and  
12th St.  
Buyer: M. Vehon.
- Ryan Tailoring Co., 201 Madison St  
Buyer: H. J. Franks.
- Schettnitz Bros. & Mayer, 229 Monore St.;  
cloth hats and caps.
- Schmidt, W. D., & Co., 147 Fifth Ave.  
Buyer: T. E. Frazee.
- Schweitzer, A. & Co., 167 Fifth Ave.;  
general line.  
Buyer: A. Schweitzer.
- Shauer, G. G. & Bro., 221 Fifth Ave.;  
overalls and pants.  
New York office, 42 12th St.
- Singer, A. L. & Co., 173-175 Adams St.;  
uniforms and tailoring.  
Cloth, A. L. Singer.  
Trimmings, H. Osborne.
- Sitron, A. & Co., 192 Van Buren St.;  
men's clothing, woolens.  
Buyer: A. Sitron.
- Solomon, J. & Co., 215 E. Madison St.;  
general line.  
Buyer: J. Solomon.
- Sonneborn, Hy. & Co., 240 Franklin St.
- Spitz, Landauer & Co., 239 Market St.;  
boys' clothing.  
Buyer: S. Spitz.
- Spitz & Schoenberg Bros., 238-240 Market  
St.; boys' and children's clothing.  
Buyer: A. Schoenberg.
- Stern & Shohl, 225-27 Jackson Blvd.;  
youth's, boys', children's clothing.  
Buyer: D. S. Stern.
- Stern, Schafer & Decker, 234 Fifth Ave.;  
general line.  
Buyer: John Schafer.
- Strauss, E. E. & Co., 246 Market St.;  
general line.  
Buyers: E. E. Strauss, H. Meyer.
- Strauss Bros., 235 Market St.; general  
line.  
Buyers: G. C. Strauss and M. M.  
Strauss.
- Strauss, Eisendrath & Co., 244-246 Jack-  
son Blvd.; boys' clothing, shirts and  
pants.  
Buyer: L. Eisendrath.  
New York office, 40 Thomas St.
- Sutton, Wm. H. & Co., 242-244 Market St.;  
children's and young men's.
- Sweet, Orr & Co., 230 Market St.; over-  
alls.
- Taylor & Parrotte, 180 Market St.; hats.
- Thomas & Davies, 12 Jackson Blvd.
- Tinsley, J. W., & Son, 1237 75th St.
- Wachsmuth, L. C. & Co., 221 Market  
St.; general line.  
Buyers: L. C. Wachsmuth, F. H.  
Wachsmuth.
- New York office, 60 Leonard St.  
Resident Buyer: Geo. H. Dallon.
- Weil, Meyer, 254 Franklin St.
- Weil, Pfbaum & Co., 246 Market St.;  
boys' and children's clothing.
- Werthan, Geo., 235 Jackson Boul.; gen-  
eral line.
- Whitney, Christenson & Bullock, 196-200  
Market St.
- Winer Bros., 471 S. Canal St.; overalls.
- Witkowsky, J., 225 Market St.; general  
line.  
Buyer: J. Witkowsky.
- Wolfson & Miller, 573 S. Canal St.; over-  
alls.
- Work Bros. & Co., Wabash & Monroe  
Sts.; general line.  
Buyer: A. S. Work.  
New York office, G. W. H. Dallon,  
58 Leonard St.
- Wurzburg, H. J. & Co., 221 Market St.;  
pants.

---

### Cincinnati.

---

- Albrecht, Chas. H. Co., The, 615-617 Main  
St.; carriage fringes.
- Bettman, Bloom & Co., 24 West Third  
St.; general line.  
Buyer: Mr. Bloom.
- Bettman Bros. & Co., 121 West 3d St.  
General line, Mr. Bettman.
- Bing, I. & S., 137 West 4th St.; general  
line.  
Buyers: Sam Bing, Sidney H. Bing.
- Bloch, Abe, & Co., 810 Main St.; general  
line.  
Buyers: Abe Bloch, J. Bloch.
- Bloom, Cohn & Co, Pearl, cor. Race St.;  
general line.  
Buyers: Abe Bloom, J. Cohn.  
New York office, 53 Worth St.
- Cooper Mfg. Co., 121 Schillito Place.
- Ettlinger, M. & Co., 23 West Third St.;  
general line.  
Buyer: Isaac Ettlinger.
- Faller, Isaac, Sons & Co., 421 Race St.;  
job lot counter goods.
- Farbach Bros., 10 E. Pearl St.; pants.
- Fechheimer Bros. & Co., 18 West 5th St.
- Fechheimer, Kiefer & Co., 119 W. 4th St.;  
general line.  
Buyer: S. H. Fechheimer.  
New York office, 59 Leonard St.
- Feder, Silberberg & Co., 30 West Third  
St.; general line.  
Buyer: Mr. Silberberg.  
New York office, 640 Broadway.
- Freiberg, Sickels & Co., 116 West Third  
St.; general line.  
Buyers: S. Sickels, J. Freiberg.
- Geiershofer, Henry, & Co., 133 West  
Fourth St.; general line.  
Buyer: Henry Giershofer.
- Goldman, Beckman & Co., Third St. cor.  
Vine.  
General line, H. Beckman.  
New York office, room 600 Textile  
Bldg.
- Hart, Isaac, & Co., 5 West 3d St.;  
clothing, worsteds a specialty.  
Buyer: Mr. Koch.
- Heldman, Heldman & Co., 26 West Third  
St.; general line.  
Buyer: Mr. Heldman.
- Holberg, F. & Co., 4 E. Pearl St.; men's  
suits and overcoats.  
Buyer: H. Holberg.

Hunter Tailoring Co., 119 West Fifth St.; general line.  
 Buyer: J. D. Samelson.  
 Huss Bros., 150 West Fifth St.; pants.  
 Buyer: Mr. Huss.  
 Levy, Price & Co., 33 West 3d St.; boys' and children's.  
 Loeb & Koch, 229 Race St.  
 Marks, M. H. & Co., 20 West Pearl St.; overcoatings and summer goods.  
 Buyer: Moose Marks.  
 New York office, 727 Broadway.  
 Mayer, Scheuer, Offner & Co, Third and Vine Sts; general line.  
 Buyers: T. Mayer, A. Offner.  
 New York office, room 600 Textile Bldg.  
 Menderson Clothing Co., 320 Race St.; general line.  
 Buyer: J. Menderson.  
 New York office, care of Wallach Hoexter & Co., 74 Leonard St. (also St. Louis).  
 Moch, Berman & Co., 31 West Third St.; general line.  
 Buyers: Albert Moch, Charles Moch.  
 New York office, W. L. Strong & Co., 56 Worth St.  
 Ochs, Goodman & Co., 104 West 3d St.; general line.  
 Buyer: Mr. Ochs.  
 New York office, care of S. Rosenberg, 636 Broadway.  
 Oppenheimer, Straus & Co., 120 W. Third st.; pants, furnishing goods.  
 Buyer: E. Oppenheimer.  
 New York office, 576 Broadway.  
 Pettibone Bros. Mfg. Co. (uniforms), 630 Main St.  
 Riverside Tailoring Co. (Wm. Stern prop'r), 131 W. 3d St.  
 Rosenthal & Mayer, Globe Tailoring Co., 314 Elm St.  
 Samelson, J. D. & Co., 119 W. 5th St.  
 Buyer: J. D. Samelson.  
 Sanford, Storrs & Varner, Third & Race Sts.  
 Buyer: Mr. Sanford.  
 Schwartz, G., Vine and Pearl Sts.; general line.  
 Buyer: G. Schwartz.  
 Seasongood, Troy & Krouse, 221 W. 4th St.; general line; Mr. Seasongood.  
 Seinsheimer, H. A. & Co., 15 West 3d St.; children's clothing.  
 Buyers: Henry Seinsheimer, Arthur Bowman.  
 Sommerfield, A. & A. W. & Co., 35 West Pearl St.; pants, summer goods, overcoats.  
 Buyers: Abe Sommerfield, Adolph Sommerfield.  
 Stern, Lauer, Shohl & Co., 310 Vine St; general line.  
 Buyer: A. S. Stern.  
 Stern, Wm., Riverside Tailoring Co., 113 W. Third St.  
 Buyer: Mr. Stern.  
 Stricker, Beitman & Co., 112 West Third St.; pants.  
 Buyers: Mr. Stricker, Mr. Beltman.  
 Sturm, G. & Sons, 124-26 W. 3rd St. general line.  
 Buyers: Mr. N. H. Sturm, S. W. Sturm.  
 Trounstine Bros. & Co., 316 Elm St.; general line.  
 Buyer: Mr. Sam Trounstine.  
 Union Merchant Tailoring Co., Pearl and Vine Sts. (Trounstine & Winkelr.)  
 Verkamp, G. H. & Sons, 5th and Plum Sts.

Weiler, S. L., 309 Race St.; pants.  
 Buyer: S. L. Weiler.  
 Wenstrup, Jos. H. & Co, 310-312 W. Fifth St.; men's, boys' and children's clothing.  
 Wolfson Bros. & Co., 29 W. Third St.; boys' and children's clothing.  
 Buyer: J. Wolfson.  
 Wolfson, Kahn & Co., 28 West Pearl St.; general line.  
 Buyer: B. Wolfson.  
 Wyler, Ackerland & Co., 9 West Third St.; general line.  
 Buyers: Ed. Wyler, Louis Wyler.  
 New York office, 600 Textile Bldg.

**Cleveland.**

Cohn, Harris & Bro., 116 St. Clair St.; general line.  
 Enterprise Mfg. Co., The, 102 St. Clair St.; pants, shirts and overalls.  
 Buyer: C. K. Sunshine.  
 Epstein, B. & Co., 1051 Pearl St.  
 Fineberg & Walpaw, 78 Bank St.; pants.  
 Fox & Co., 133 Bank St.; pants.  
 Freedman Bros., 198 Bank St.  
 Goldsmith, Joseph, Feiss Co., The, 113-117 St. Clair St.; general line. (Also at Pittsburgh, Renshaw Bldg., Sam Frank, agt.)  
 Buyers: Mr. Goldsmith, Mr. Feiss.  
 Greenfield, S. & Co., 200 Bank St.  
 Halle, Schwartz & Skall, 107 St. Clair St.  
 Kohn Bros. & Heller, 78-80 Bank St, overcoats and summer goods.  
 Buyer: Mr. Kohn.  
 Kohn, S., 180 Bank St.  
 Kornhauser, Alt & Wilner, 68 Water St.  
 Liebenthal, Bloch & Co., 108 St. Clair St.; pants and coats.  
 Buyers: Both members.  
 Miller, Weizenhof & Co., 191 Bank St.; general line.  
 Richman, N. G. Co, The, 74-76 Water St; men's, boys' and children's suits and overcoats.  
 Root & McBride Co., Bank St.  
 Rosenblatt Bros, 119 St. Clair St.; overalls, shirts, etc, pants.  
 Buyer: Mr. Rosenblatt.  
 Witkowsky, A., 275 St. Clair St.; pants and overalls, vests.  
 Buyer: A. Witkowsky.  
 Witkowsky & Mahrer, 100-102 St. Clair St.; caps and cloth hats.  
 Buyer: A. Mahrer.

**Detroit.**

Berman, Wine & Co., 277-279 Gratiot Ave.  
 Carhartt, Hamilton, 479-487 Michigan Ave.; overalls and pants.  
 Buyer: H. R. Wetmore.  
 Detroit Cap Mfg. Co., 11-15 W. Woodbridge St.  
 Buyer: Sigmund Hofmann.  
 Goldsmith, Chas. & Co., 362 Gratiot Ave.; overalls and pants.  
 Goldstein, S. & Co., 131 Jefferson Ave.; children's and boys' clothing.  
 Jacobs, A. & Co., 307 Gratiot Ave.; overalls.  
 King, M., & Son, 253 Gratiot Ave.  
 Larned, Carter & Co., Michigan Ave. and Park Pl.; overalls, pants, corduroys.  
 Buyer: A. E. Larned.

Morgan, Puhl & Morris Co., 47-49 Gd. River Ave.; uniforms.  
 Peerless Mfg. Co., The, 33 E. Larned St.; pants, shirts and overalls.  
 Buyer: W. Saulson.  
 New York office, 79 Walker St.  
 Rosen, A. D. & Co., 257 Gratiot Ave.; pants and overalls.  
 Rosenfield-Monroe Co., 179 Jefferson Ave.; pants and overalls.  
 Schloss Bros., 184-188 Jefferson Ave.  
 Buyer: A. W. Schloss.  
 Schloss, M. I., 143 Jefferson Ave.; general line.  
 Buyer: M. I. Schloss.  
 Stanton, M. M., 124-126 Jefferson Ave.; furnishing and piece goods, pants and overalls.  
 Buyer: M. M. Stanton.  
 New York office, 95 Franklin St.  
 Wolenburgh, Mrs. Hart, 237 Gratiot Ave.; children's clothing.

### Dubuque, Ia.

Platt, Buckingham & Co.; shirts, overalls, trousers, duck coats.

### Indianapolis.

Balley Mfg. Co., 366 So. Meridian St.; pants, shirts and overalls.  
 Harseim, R. G., 22 West Georgia St.; pants and overalls.  
 Havens & Geddes Co.; pants and overalls.  
 Kahn Tailoring Co.; general line.  
 Buyer: Mr. Kahn.  
 Lion Clothing Mfg. Co., 340 S. Penn St.

### Kansas City, Mo.

Barmon, William, 113 West Sixth St.  
 Burnham-Munger Mfg. Co., 308 W. 6th St.; overalls and shirts.  
 Buyer: W. B. Thomas.  
 N. Y. office, 43 Leonard St.  
 Cohn, Kirschbaum & Co., 607 Main St.; woolens and tailors' trimmings.  
 Driggs & Stone Mercantile Co., 1520 Main St.; jean pants and overalls, shirts.  
 Buyer: E. R. Stone.  
 Reicher, M., 533 Delaware St.  
 Buyer: Sol Reicher.  
 Star Pants Co., 6th and Central Sts.  
 Woolens and trimmings, Ike Isaacs, A. I. Robins.

### Louisville.

Bray Clothing Co., The, 135-139 Sixth St.; cassimeres, corduroy, kerseys.  
 Buyer: D. N. Whayne.  
 Coleman Bros. Clothing Co., 1102 West Main St.  
 Defiance Clothing Mfg. Co., 223 N. 6th St.  
 Buyer: N. Kymanski.  
 N. Y. office, care of Max Loewenthal, 808 W. Chester Ave.  
 Fall City Shirt Mfg. Co., 8th and Main Sts.; shirts.  
 Hilpp, Richardson & Co., 633 West Main St.; general line.  
 Buyers: Mr. Hilpp, Mr. Richardson.  
 Kahn Bros., 849 W. Main St.  
 Buyer: D. R. Kahn.  
 Kentucky Jeans Clothing Co., 700 West Main St.; jean pants and clothing.  
 Landrum, Tom J. & Co., 224 Sixth St.; woolens, jeans, etc.  
 Levitan, A., 618 W. Main St.

Louisville Clothing Co., 1500 Portland Ave.  
 Moses, L. & Co., 640-642 West Main St.; general line.  
 Buyers: J. Moses, S. Moses.  
 Nelson, Van B. Mfg. Co., 229 Seventh St.  
 Ox Breeches Mfg. Co., 835-841 W. Main St.; pants.  
 Buyer: G. G. Summers.  
 Robinson, J. M., Norton & Co., 537 W. Main St.; woolens, jeans and jean clothing.  
 Buyer: B. Booker Robinson.  
 Shuttleworth, J. A. & Co., 607 West Main St.; general line.  
 Buyer: J. A. Shuttleworth.  
 Shymanski, Schneider & Wolf, 235 Seventh St.; men's and boys' clothing.  
 Tapp, Leathers & Co., 823-825 West Main St.; jeans clothing.  
 Buyer: P. H. Tapp.  
 Urbansky, A., & Co.

### Milwaukee.

Aarons, Marks & Co., 345 Eats Water St.  
 Abeles, F. E. & Co., 280 East Water St.; pants, shirts, overalls and furnishing goods.  
 Buyer: F. E. Abeles.  
 New York office, 95 Franklin St.  
 Adler, David & Sons Clothing Co., 325 East Water St.; general line.  
 Buyer: I. D. Adler.  
 Bellack, Chas. H. Co., The, Grand Ave. and Fourth St.; general line.  
 Buyer: Chas. H. Bellack.  
 New York office, 76 Leonard St.  
 Cohen Bros. Co., Broadway and Buffalo St.; shirts, pants, overalls, etc.  
 Buyers: Y. Cohen, P. Asch.  
 New York office, 93 Franklin St.  
 Eureka Pants Co., 370 Broadway; pants.  
 Buyer: Mr. Levy.  
 Fein's Bro. & Co., 570 E. Water St.  
 Friend & Marks, 353 East Water St.  
 Friend Bros. Clothing Co., Broadway and Michigan Aves.  
 Buyers: D. H. Friend, Jos. Friedberg.  
 New York office, room 16, 52 Franklin St. (also at St. Paul).  
 Goll & Frank Co., 255 E. Water St.; pants and overalls.  
 Buyer: Chas. Ranser.  
 Gottschalk, J. L. Co., 323-325 Chestnut St.  
 Buyer: Joseph Gottschalk.  
 Landauer & Co., 216 E. Water St.  
 Mahler, Albenberg & Co., 329 Broadway; pants, shirts, overalls, etc.  
 Buyer: E. Mahler.  
 People's Tailoring Co., J. and S. Polack, props; 250-252 West Water St.; general line.  
 Buyer: Mr. Polack.  
 Rice, J. H. & Friedman, 19th and Lloyd Sts.; pants and overalls.  
 Shakman, J. H. & Co., 349 E. Water St.; general line.  
 Buyer: L. A. Shakman.  
 Stern, H., Jr., Bro. & Co., 335 Broadway; shirts and pants.  
 Whitehead, M. B., 326 Broadway.

### Minneapolis.

Plymouth Clothing House, The; general line cloths.

Robitshek, Frank, & Heller, 18-22 Third St., North; pants, shirts and overalls.

Buyer: Mr. Frank.

Tallant, F. E., 38 South 3d St.

### Newark.

Colyer & Co., 815 Broad St.; costume, ready made and uniform clothing.

Buyer: Geo. W. Schoner.

Hines, J. H. & Son, 561 Broad St.

Buyer: J. H. Hines.

Marshall, J. & Ball, 807 Broad St.

Buyer: Mr. Roberts.

New York office, 34 Thomas St, Geo H. Dallan, R. 23.

McGregor & Co., 850 Broad St.

Buyer: Mr. McGregor.

Stoutenborough & Co., 799 Broad St.

Buyer: Mr. Stoutenborough.

Watson, Geo. & Co., 795 Broad St.

Buyer: Mr. Weeks.

### New York.

Abrahams, Mark L. & Bro., 35 West 3d St.; boys' and children's.

Abrams, A., 5 Walker St.; pants.

Abrams, M. H. & Co., 38 Walker St.; pants.

Abrams, S. J. & Son, 44 Walker St.

Ackerman, Jacob, 101 Broadway.

Adelson, L., 137 Greene St.

Adler & Livingstone, 119 Bleeker St.; pants.

Adler, E. J. & Co., 733 Broadway; infants' and children's clothing.

Buyer: Mr. Adler.

Adolph, Joseph, 44 Broome St.

Alsberg, Moritz & Co., 20 Waverly Place.

Ambach Bros. & Co. (Balt.), 751 Broadway; general line, medium grade.

Buyer: Mr. Ambach.

Amdur Bros., 430 Broome St.

Ansorge, Mark P., 4 West 3d St.

Applebaum, M., 8 E. 14th St.; cloaks and suits.

Arnheim, Marks, 767 Broadway; general line (custom only.)

Buyer: M. Arnheim.

Arnold, Louchheim & Co., 716 Broadway.

Arons, Sherwin & Co., 22 West 4th St.

Arons, Adolph & Co., 39 Bond St.

Bachrach & Loewenstein, 119 Bleeker St.

Bamberger Bros, 3 Waverly Place.

Bargain Clothing Mfg. Co, 212 Wooster St.

Barnett, J., 489 Canal St.

Baum, Chas. S. & Son, 59 Fourth Ave.

Baum, M. & Co., 20 Waverly Place.

Benedict Bros., 76 Franklin St.; shirts and overalls.

Benjamin, Alfred, & Co, 49 Lafayette Pl; fine goods and summer clothing.

Buyers: Mr. Hochstadter and Mr. Josephy.

Berman, M., 41 E. Broadway.

Bernhard's, J, Sons, 738 Broadway; bicycle suits and summer clothing.

Bernhelmer & Arnold, 21 Lafayette Pl.

Bernstein, B, 626 Broadway.

Bernstein Bros., 598 Broadway.

Bernstein, J, 235 Mercer St.

Berrent & Monasewitz, 95 Bleeker St.

Bick Bros., 19 West 4th St.; general line, low and medium.

Buyer: Mr. Bick.

Blatt, Joseph S. & Co., 11 East 4th St.; general line.

Buyer: J. S. Blatt.

Blinline, E. L. & Co., 9 Great Jones St.; boys' clothing.

Bloch, H. M. & Bro, 15 Waverly Pl; pants.

Buyer: H. M. Bloch.

Block, M., 88 East Broadway.

Bloom, R. W. & Sons, 712 Broadway; pants.

Buyer: R. W. Bloom.

Blum, Samuel, 62 Walker St.; boys' and children's suits, low and medium grades.

Blumenson, H. A. & Co., 57 Walker St.

Blumenthal Bros. & Co., 705 Broadway.

Bober & Oskinsky, 115 Division St.

Boylan Mfg. Co., 43-45 E. 19th St.; military clothing.

Brackman & Son, H., 16 Waverly Pl.

Bramson, Chas., 64 E. Broadway.

Brand Bros, 588-590 Broadway; pants.

Buyer: Mr. Brand.

Brash, Edward, 725-727 Broadway; children's clothing.

Brett, I., 2380 Third Ave.

Brodek, H. A., 736 Broadway.

Brody & Schnuer, 710 Broadway; pants.

Brody & Stroll, 84 East Broadway; children's clothing.

Brokaw Bros., 22 Astor Pl.; medium and high grades (retail only).

Buyer: Wm. Brokaw.

Bronberg, Richard & Co., 751 Broadway.

Brooks Bros, Broadway and 22d St.

Brown, I. & Bro., 3 Great Jones St.

Brown Bros. & Co. (San Francisco), 21 Lafayette Pl.; general line.

Buyer: R. Brown.

Brown, Fishbein & Barit, Elm near Bleeker St.

Browning, King & Co, 408 Broome St; general line.

Buyer: W. C. Browning.

Brummer, Max B., 735 Broadway; pants.

Buyer: M. B. Brummer.

Bursky, N., 23 E. Broadway.

Cane, McCaffrey & Co, 739-741 Broadway; boys' and children's.

Buyer: Mr. Cane.

Carey & Sides, 82 4th Ave.; general line (retail only).

Buyer: Mr. Carey.

Castor, Geo. A. & Co., 14 John St.; general line (custom only).

Buyer: Mr. Morley.

Cedar Bros., 710 Broadway; general line.

Buyer: Phil Cedar.

Chock, P, 710 Broadway.

Chorosh & Rogers, 97 Crosby St.; children's clothing.

Claffin Co., H. B., Worth and Church Sts.

Cohen, A. & Co., 35 Great Jones St.

Cohen, C. & H., 684 Broadway.

Cohen, Endell & Co., 576 Broadway; pants.

Buyer: Mr. Cohen.

Cohen & Fine, 716 Broadway.

Cohen, Goldman & Co., 745 Broadway; medium and high grade pants.

Buyer: Mr. Goldman.

Cohen, I. & Co., 30 Great Jones St.; general line.

- Cohen, J., 24 Bond St.  
 Cohen, Joseph, 714 Broadway.  
 Cohen, Jacob & Co., 39 Bond St.  
 Cohen & Lang, 691 Broadway.  
 Cohen & Levison, 35 E. 10th St.; children's clothing.  
 Cohen & Levy, 625 Broadway; general line, low and medium grades.  
 Buyer: Mr. Levy.  
 Cohen & Price, 82 East Broadway.  
 Cohen & Robinowitz, 27 Walker St.  
 Cohen, Walkowsky & Wasserman, 266 Grand St.  
 Cohn, Brown & Co., 715 Broadway; boys' and children's clothing.  
 Buyer: Mr. Cohn.  
 Cohn, H. & Co., 41 Great Jones St.  
 Cohn, Joseph & Son, 588 Broadway.  
 Cohn, M. & Co., 749 Broadway; children's clothing.  
 Cohn, M. & Sons, 716 Broadway.  
 Colvin & Schain, 42 Walker St.  
 Combination Children's Clothing Co., 708 Broadway.  
 Cooper, Al, 204 Greene St.  
 Cosel & Goldstein, 25 East 4th St.; men's clothing.  
 Cowen, Mark, 22 West 4th St.; men's fine clothing, uniforms.  
 Crouse & Brandegee, 682 Broadway.  
 Danzig & Eisenberg, 13 Walker St.  
 David Bros. & Co., 26 Lafayette St.; boy's and children's.  
 Buyer: J. David.  
 Davidson & Blankfort, 92 Bleecker St.  
 Davidson & Horwitz, 209 Greene St.  
 Davidson & Prince, 712 Broadway; general line.  
 Davis, A. S., 736 Broadway; pants.  
 Davis, Isaac L. & Co., 47 Great Jones St.  
 Dubinsky, Louis, 137 Canal St.  
 Dyorkin, J., 95 Bleecker St.; boy's clothing.  
 Ehrman & Stern, 26 Lafayette Pl.  
 Eisenberg, J. & Bro., 34 Bayard St.  
 Eisner, J., 152 Wooster St.  
 Ellas, Harris & Sons, 65 E. Broadway, general line.  
 Buyer: H. Ellas.  
 Empire Mfg. Co., 153 Greene St.  
 Englander, B., 622 Broadway; boy's clothing.  
 Ernst, Max, 715 Broadway; general line.  
 Buyer: M. Ernst.  
 F. B. Q. Clothing Co., 22 Lafayette Place; general line.  
 Buyer: J. C. Bernheim.  
 Fehheimer, Fishel & Co, 748 Broadway; general line.  
 Buyer: Mr. Fishel.  
 Fine, M. & Sons, 44 Walker St.; overalls.  
 Fineman, A., 48 E. Broadway.  
 Finkelbrand, Walcoff & Co., 11 East 4th St.; pants.  
 Finkelstein, Louis, 39 Great Jones St.  
 Finkelstein & Maaget, 50 Bond St.; children's clothing.  
 Finkelstein, M. & Son, 37 Walker St.  
 Finklestein & Rosenbaum, 5 Waverly Place.  
 Frank, Ivan & Co., 783 Broadway; children's clothing.  
 Frank, Wm. P., 52 Lafayette Pl.; pants.  
 Frankel, S., 53 Walker St.  
 Frankfurt & Shaine, 731 Broadway;  
 Fried, Louis J. & Co., 58 E. Eleventh St. children's clothing.  
 Friedman & Co., 33 Lispenard St.  
 Friedman Bros. & Co., 628 Broadway.  
 Friedman, H. M. & Co., 33 Lispenard St.  
 Friedman, J. & Co., 719 Broadway.  
 Garbulsky, S., 235 Mercer St.  
 Garson, Meyer & Co. (Rochester); 695 Broadway; general line.  
 Geis & Berger, 751 Broadway.  
 Gerson, Jacobson & Co., 661 Broadway; general line.  
 Gingold Bros., 128 Bleecker St.  
 Ginsberg, Colin & Rosenthal, 714 Bdwy.  
 Ginsberg, I., 174 Wooster St.; wrappers.  
 Glueckmann & Gross, 729 Broadway; boys' and children's, also bicycle suits.  
 Goldberg, B. B., 787 Broadway.  
 Goldberg, H. & Sons, 29 East Broadway  
 Goldberg, I., 21 Broadway.  
 Goldberg, Harris & Co., 753 Broadway; children's clothing.  
 Goldberg, Solomon & Co., 15 E. Houston St.; cloaks and suits.  
 Goldberg, Meyer, I., 27 Walker St.  
 Golde, S. & Sons, Wooster and Third Sts.; boys' and children's low and medium grades.  
 Buyer: Mr. M. Golde.  
 Goldman & Nelkin, East Broadway and Catharine St.  
 Goldman & Suchman, 751 Broadway; pants.  
 Goldstein, Louis, 22 E. Broadway.  
 Goldstein, N. & Son, 30 Bond St.  
 Golland's, I. Sons, 809 Broadway; general line.  
 Buyer: I. Golland.  
 Goodman & Mintz, 749 Broadway.  
 Gotthelf, Sam, 588-590 Broadway.  
 Gottlieb Bros., 131 Bleecker St.; suits.  
 Greenbaum, J. L. & Co., 649 Broadway.  
 Greenberg & Dube, 192 Greene St.  
 Greenstein & Simon, 59 4th Ave.; children's clothing.  
 Greenthal, H. & Co., 7 Lafayette Pl.  
 Greenwald, B. & Co., 438 Broadway; overalls.  
 Gressman, Morris, 213 Greene St.  
 Greff, L. & Bro., 705 Broadway.  
 Gross Bros., 14 Waverly Pl.; children's clothing.  
 Gross, H., 90 Avenue B.  
 Grossman, Michaelson & Co., 739 Broadway, formerly of Chicago.  
 Gumbiner & Fox, 661 Broadway.  
 Hackett, Carhart & Co., 422 Broadway; general line.  
 Buyer: Mr. Nedwell.  
 Halprin & Louis, 34 Walker St.  
 Hamburger Bros. & Co. (Balt.), 777 Broadway; medium and fine grades.  
 Hammerslough Bros. 830 Broadway; general line.  
 Buyer: Ed. Hammerslough.  
 Hammerslough, Isidore, 52 Lafayette Pl.; boys' and children's.  
 Buyer: I. Hammerslough.  
 Hammerslough, Samuel, Co., 687 Broadway; general line, medium and fine grades.  
 Harris Bros., 97 Bleecker St; suits and overcoats.



Hastings Clothing Co., 7 W. 18th St.  
 Hays, Levi & Co, 13 Washington Place; general line.  
 Buyer: Mr. Hays.  
 Hecht & Co., 125 Prince St.; boys' suits.  
 Heidelberg, Herman & Co., 725 Broadway; general line.  
 Buyer: H. Heidelberg.  
 Heidelberg, Wolff & Co., 644 Broadway.  
 Heller & Co., 67 Spring St.; boys' and children's bicycle and golf suits.  
 Buyer: Mr. Heller.  
 Heller, Rothschild & Lang, 760 Broadway; pants and summer clothing.  
 Buyer: Mr. Rothschild.  
 Herrman, Julius & Co., 688 Broadway; boys' clothing.  
 Buyer: Mr. Herrman.  
 Hershfield, L. & Bro, 624 Broadway; pants.  
 Buyer: L. Hershfield.  
 Heumann Bros., 398 Broome St.  
 Hexter Bros. (Balt.), 733 Broadway; general line, also summer clothing.  
 Hippel, Jacob & Co, 714 Broadway; boys' and children's.  
 Hochstadter & Wallach, 836 Broadway; children's.  
 Hoffman & Marks, 710 Broadway.  
 Hoffman, Rothschild & Co. (San Francisco), 564 Broadway; general line.  
 Buyer: Mr. Rothschild.  
 Holzman Bros., 745 Broadway; boys' clothing.  
 Hornthal, Benjamin & Riem, 26 E. 14th St.; general line.  
 Buyer: Mr. Benjamin.  
 Horwitz, J., 28 Waverly Pl.; children's clothing.  
 Horwitz, H., 598 Broadway; children's clothing.  
 Hosch, Simon, 9 Washington Pl.; children's clothing.  
 Hyams & McCormack, 690 Broadway; children's clothing.  
 Isaacs, Bendet, 4 Great Jones St; general line.  
 Buyer: B. Isaacs.  
 Israel, Elias J., 54 E. 8th St.; caps.  
 Jacobs, A. Sons & Co, 623 Broadway.  
 Buyer: M. Jacobs.  
 Jacobs, Lewis, & Sons, 712 Broadway.  
 Jacobs, L. M., & Bros, 37 Clinton Place.  
 Jacobs Bros., 143 Bleecker St.  
 Jacobson, L. & Son, 716 Broadway.  
 Jacobson, Weil & Jacobson, 26 Lafayette Pl.  
 Jacoby Bros. (Los Angeles, Cal.), 707 Broadway.  
 Joel, J. A. & Co., 88 Nassau St.; uniforms.  
 Joseph, S., 128 Bleecker St.  
 Kahn & Co., 714 Broadway.  
 Kahn, Dreyfus & Co, 638 Broadway.  
 Kahn-Feinberg Co., The, 114 Bleecker St.  
 Kamber, R. & Co., 624 Broadway.  
 Kaplan & Mendelson, 21 W. Houston St.  
 Kaufman, Isidore, & Co, 737 Broadway; boys' and children's.  
 Buyer: I. Kaufman.  
 Kirschbaum, Ab. & Co. (Phila.), 735 Broadway; general line.  
 Buyer: Mr. May.  
 Klee & Co., 22 Lafayette Pl.; general line.  
 Buyer: Mr. Klee.  
 Kohn & Co., 23-29 Washington Pl.; general line.  
 Buyer: Mr. Kohn.

Korn, Holzman & Co., 733 Broadway.  
 Korn, S. W., Son & Co., 574 Broadway.  
 Buyer: S. W. Korn.  
 Kratzenstein, Herman & Co., 654 Broadway; general line.  
 Buyer: H. Kratzenstein.  
 Krupp & Berman, 598 Broadway.  
 Kuhn, H. & Sons, 708 Broadway; boys' and children's.  
 Buyer: Mr. S. C. Kuhn.  
 Lamkay, J. & Co, 2-1-6 Astor Place.  
 Lampel, Samuel, 35 Great Jones St.; children's clothing.  
 Landau & Goldberg, 11 Washington Place; boys' and children's.  
 Lange & Walsh Mfg. Co, 596 Broadway.  
 Lauterbach, Wm., 26 Lafayette Pl.; pants.  
 Leo, Max, 130 Bleecker St.  
 Levine, M. D. & Co., 9 Walker St.  
 Levi, Abrams & Co., 16 Walker St.  
 Levinson, S. & Co., 710 Broadway.  
 Levy & Abrahams, 699 Broadway; pants and suits.  
 Buyer: Mr. Levy.  
 Levy Bros., 55 Great Jones St.  
 Levy, Henry, R. & Bro., 44 East 14th St.; summer clothing and novelties.  
 Levy, Horwitz & Lachenbruch, 96 Bleecker St; men's, boys' and children's low and medium grades; worsted suits a specialty.  
 Levy, Isaac, 12 West 4th St.; hats and caps.  
 Levy & Weinstein, 18 West 4th St.; cloaks and suits.  
 Lewbel & Sheinberg, 35 Great Jones St.; children's clothing.  
 Lewinson, A. & Co, 111 Bleecker St; boys' and children's.  
 Light, B., & Co., 632 Broadway; men's and boys'.  
 Buyer: B. Light.  
 Light & Schlesinger, 37 W. 3rd St.  
 Lippman, G. & Sons, 707 Broadway; boys' and children's.  
 Buyer: Harry Lippman.  
 Lippman, L. & Sons, 702 Broadway; general line, medium and fine grades.  
 Buyer: J. Lippman.  
 Lippmann, Martin B., 636-638 Broadway.  
 Lipps Bros., 736 Broadway.  
 Lithauer's, L. Sons, 723 Broadway; general line.  
 Buyer: T. Lithauer.  
 Loeb & Waldenheimer, 737 Broadway; boys' and children's.  
 Buyer: Mr. Waldenheimer.  
 London & Lewengood, 152 Wooster St.  
 Loth, Moritz, & Co., 215 Greene St.; pants.  
 Buyer: M. Loth.  
 Lubell & Sandusky, 55 Great Jones St.  
 Ludwig, L. & Co., 30 Great Jones St.  
 Mandel, Pursch & Wiener. (San Francisco), 127 Mercer St.; low and medium grades.  
 Mann, Leon, 55 Great Jones St.  
 Marks, D. (N. E. Pants Co.), 199 Greene St.  
 Marks, David, & Sons, 687 Broadway; general line of fine goods.  
 Buyers: Mr. Levy and Mr. Marks.  
 Marks, M. A. & Co. (Also New Orleans, La.), 580 Broadway; for Southern trade.  
 Buyer: Mr. Lowenburbg.  
 Martin Bros., 22 West 4th St.

- Max Bros. & Co., 192 Greene St.  
 McKeon, John S. & Co., 702 Broadway;  
 general line.  
 Buyer: J. S. McKeon.
- Meltsner, Chas. N. & Bros., 237 Mercer  
 St.
- Mendelson, J. & Bros, 636 Broadway.  
 Youths' and children's.  
 Buyer: Chas. Michael.
- Metzendorf Bros., 54 West 3d St.; cloaks.  
 Michael, L. & Co., 627 Broadway.  
 Buyer: Mr. Michaels.
- Michaels, Stern & Co. (Rochester), 756  
 Broadway; general line.
- Michel, S. & Sons, 18 West 4th St.;  
 men's, youths' and boys'.
- Miller, S. F. & A. F. & Co., 760 Broad-  
 way.
- Monarch Clothing Co., 46 Great Jones St.  
 Monness, H. & Son, 112 Bleecker St.;  
 children's clothing.
- Morrison & Mashkowitz, 80 East Broad-  
 way.
- Moss Bros, 737 Broadway.  
 Buyer: J. Moss.
- Murphy, E. F. & J. P., 795 Broadway;  
 boys' and children's.
- Nanes & Quint, 209 Greene St.
- Narinsky, Henry, 36 Walker St.
- Nathan Bros., 702 Broadway; general  
 line.  
 Buyer: Mr. Nathan.
- Nathan, S. J., Son & Co., 707 Broadway;  
 general line.  
 Buyer: S. J. Nathan.
- Naumburg, M. & W., 657 Broadway;  
 general line.  
 Buyer: Harry Kraus.
- Neugass Bros, 95 Bleecker St; low and  
 medium grades, men's, boys' and  
 children's.
- New, A. & Co, 737 Broadway; pants.  
 Buyer: A. New.
- Newborg, D. L. & Son, 653 Broadway;  
 men's, boys' and children's low and  
 medium grades.  
 Buyer: Mr. Newborg.
- Newborg, Rosenberg & Co, 192 1-2 Greene  
 St; Men's, boys' and children's low  
 and medium grades.  
 Buyers: Mr. Rosenberg, Mr. Guthman.
- New England Pants Co., 201 Greene St.
- Northrop & Curry, 43-5-7 E. 10th St.;  
 children's clothing.  
 Buyers: Mr. Northrop and Mr. Curry.
- Oppenheim & Co., 43 Leonard St.;  
 trousers.
- Oppenheimer, V. & Co., 204 Greene St.
- Ornstein & Fainblatt, 9 Great Jones St.;  
 children's clothing.
- Osman & Lockwood, 207 Greene St.
- Peavy, J. & Bros., 15 Washington Place.  
 Buyer: Henry Peavy.
- Present & Co, 596 Broadway; pants.  
 Buyer: Mr. Present.
- Price, B. L. Mfg. Co., 111 Bleecker St.;  
 medium and low grades.  
 Buyer: B. L. Price.
- Proser, N. I. & Sons, 13 East 4th St.
- Rabbino & Copeland, 722 Broadway;  
 pants.
- Rabinowitz, A., 706 Broadway.
- Raymond, A. & Co, 131 Fulton St; gen-  
 eral line (retail only).  
 Buyer: Mr. Raymond, Jr.
- Resnek & Shapiro, 74 Canal St.
- Roebbling Mfg. Co., 743 Broadway.
- Rogers, Peet & Co, 569 Broadway; general  
 line, men's, boys' and children's.  
 Buyer: Mr. Coard.
- Rose Bros. (formerly Rosinsky Bros.), 715  
 Broadway; pants.  
 Buyer: J. W. Rose.
- Rosengardt, M. & Co., 193 Mercer St.
- Rosenthal & Cohen, 712 Broadway.
- Rosenthal, H. B. & Co, 707 Broadway;  
 pants, men's, boys' and children's.  
 Buyer: H. B. Rosenthal.
- Rosenthal, Jos, 44 East Broadway.
- Rosenthal, S. & Bro., 92 Bleecker St.
- Rosenthal Mfg. Co., 574 Broadway; gen-  
 eral line.  
 Buyer: Mr. Rosenthal.
- Rosenwasser Bros., 548 Broadway; over-  
 gaiters, leggings, etc.
- Ross, Samuel, & Son, 11, 13 East 4th St.;  
 pants.
- Rothschild, V. Henry & Co., 43 Leonard  
 St.; pants, shirt waists and shirts.  
 Buyer: Mr. Dreyfoos.
- Routenberg, Louis, 403 Broadway.
- Rubinsky & Asinof, 187-189 Mercer St.
- Rutherford & Co, 649 Broadway.
- Sachs & Davis, 419 Broome St.
- Sachs & Stern, 707 Broadway; over-  
 gaiters, leggings, etc.
- Salinger Bros., 14 Washington Pl.; boys'  
 and children's clothing.
- Samilson, Harris, 119 Bleecker St.; over-  
 coatings and suitings.
- Sampson Bros., 63 East 8th St.
- Sampter, M, Sons & Co, 15 East 4th St;  
 general line, men's, boy's and chil-  
 dren's.  
 Buyer: Arnold Sampter.
- Sanditen, M. & Co., 30 Great Jones St.
- Saperstein, Isaac, 57 E. Broadway; chil-  
 dren's clothing.
- Sarner, H. & Son, 3rd Ave. and 57th St;  
 general line.  
 Buyer: H. Sarner.
- Schafran Bros., 588 Broadway; children's  
 clothing.
- Schattman Bros, 6 Great Jones St; gen-  
 eral line.  
 Buyer: J. Schattman.
- Schiff & Solomon, 114 Bleecker St.; gen-  
 eral line.  
 Buyer: C. Schiff.
- Schiff Bros. & Co., 60 East Eleventh St.;  
 boys' clothing.
- Schiller, Moses & Co., 202 Greene St.;  
 men's and boys' clothing.  
 Buyer: Mr. Schiller.
- Schulberg & Lazarus, 690 Broadway;  
 pants.
- Schiller & Greenthal, 710 Broadway; gen-  
 eral line.  
 Buyer: Mr. Schiller.
- Schleestein, Cohn & Co., 212 Wooster St.
- Schloss Bros. & Co. (Baltimore), 762  
 Broadway; general line.  
 Buyer: Nathan Schloss.
- Schloss & Pratel, 708 Broadway; boys'  
 and children's clothing.  
 Buyer: Mr. Pratel.
- Schoen, J. H., 110 Bleecker St.
- Schulman & Solomon, 114 Canal St.
- Segall, J. & Co, 721 Broadway; general  
 line.  
 Buyer: J. Segall.
- Serphos, Sol. N. & Co., 640 Broadway;  
 boys' and children's clothing.  
 Buyer: Mr. Serphos.
- Shapiro, Samuel, 628 Broadway; boys'  
 and children's clothing.  
 Buyer: S. Shapiro.
- Shretskl, W., 39 Great Jones St.
- Shrier, 70 W. Houston St.; ladies' under-  
 wear.  
 Buyer: Mr. Shrier.

Shutter & Adler Bros., 721 Broadway; pants.  
 Buyer: Mr. Adler.  
 Siff, Louis, & Bro., 756 Broadway; pants.  
 Silberstein, L., 14 W. Fourth St.  
 Simon, T., 12 Waverly Pl.; mrgfl caps.  
 Singer, Alex, 35 Great Jones St.  
 Singer & Livingston, 10 West 4th St.  
 Sivin Bros., 192 Greene St.; children's clothing.  
 Snedeker & Co., 719 Broadway; summer clothing.  
 Buyer: Mr. Snedeker.  
 Sobel, E. & H., 710 Broadway.  
 Sohn & Oppenheimer, 22 Lafayette Place; men's, boys' and children's pants.  
 Buyer: Mr. Hell.  
 Solomon, J. & Son, 691 Broadway; men's, boys' and children's clothing.  
 Buyer: J. Solomon.  
 Solomon Bros., 749 Broadway; children's clothing.  
 Somerville Woolen Mills, 568 Broadway; general line.  
 Sonneborn, Henry & Co. (Balt.), 743 Broadway; men's and boys' clothing, low and medium.  
 Buyer: H. Sonneborn.  
 Spero, Jacob, 7 Lafayette Place. ?  
 Spero, Michael, & Co., 636 Broadway.  
 Stein, Bloch Co, The (Rochester), 718 Broadway.  
 Buyer: N. Stein.  
 Stern, B. & Son, 634 Broadway.  
 Sternberg Bros., 15 W. 4th St.; pants.  
 Buyer: Mr. Sternberg.  
 Stone, A. L. & Son, 10 West 4th St.  
 Strouse & Bros. (Balt.), 733 Broadway; general line, medium and high grades.  
 Sturtz, M. & Son, 225 Greene St.  
 Swartz, Jerkowski & Co, 708 Broadway and 15 Lafayette Pl; general line.  
 Buyer: Mr. Moss.  
 Sweet, Orr & Co. (Newburgh), 625 Broadway; pants, overalls, etc.  
 Buyer: Mr. Howe.  
 Sykes & Ab. Kirschbaum & Co., 708 Broadway; boys' and children's clothing.  
 Buyer: Wm. Sykes.  
 Tashman, G., 35 East 12th St.; children's clothing.  
 Buyer: G. Tashman.  
 Tillard, J. W. & Co., 507 West Broadway; children's clothing.  
 Tobias, Chas. O. & Weil, 65 Bleecker St.  
 Tuchmaun, Leon & Co., 62 Walker St.; men's, youths' and children's clothing.  
 Turk & Einstein, 690 Broadway.  
 Union Clothing Co, 41 Great Jones St.  
 Valentine & Rabinowitz, 725 Broadway; pants.  
 Buyer: Mr. Rabinowitz.  
 Valenstein, J. & Co., 127 Bleecker St.  
 Vogel, Wm. & Son, 611 Broadway; general line (retail).  
 Vogel Bros, 665 8th Ave; general line (retail).  
 Walcoff, Goodman & Co., 634 Broadway.  
 Wald, Adolph, 8 Astor Pl.; pants.  
 Waterman & Mittelmann, 99 Bleecker St.; children's clothing.  
 Wechsler, Leon, 723 Broadway.  
 Weinberg, M. & Co., 628-632 Broadway; boys' and children's.

Weiss & Segall, 10 Washington Pl.; children's clothing.  
 Wener, J. & Co., 719 Broadway.  
 Werner, A. L. & Co., 708 Broadway; pants.  
 Werner, Julius & Sons, 740 Broadway; general line.  
 Wertheim Bros., 18 Astor Place; pants.  
 Whitecup, Chas., 201 Greene St.  
 Wiener Bros., 28 Waverly Pl.  
 Wolfers, Goldberg & Co., 14 Lafayette Place.  
 Wolf & Abraham, 65 Bleecker St.  
 Woolf, Nathan L., 58 East 11th St.  
 Worcester Pants Mfg. Co., 107 Bleecker St.; pants and bicycle suits.  
 Wronker & Weil, 643 Broadway; pants and bicycle suits.  
 Buyer: Mr. Wronker.  
 Yagustow & Ajirck, 1 Great Jones St.  
 Yeska, Joseph, 725 Broadway.  
 Yost, Chas. A. & Co., 739 Broadway.  
 Younker, Aaron, & Co., 71 Mercer St.; pants.  
 Buyer: A. Younker.  
 Younker, B. & Co., 708 Broadway; pants.  
 Buyer: B. Younker.  
 Younker, L. M., Son & Co., 627 Broadway; pants.  
 Buyer: L. M. Younker.  
 Zeman Bros., 594 Broadway; children's clothing.  
 Zimmerman & Hoexter, 193 Mercer St.  
 Zimmerman, Morris, 107 Bleecker St.; pants.  
 Buyer: M. Zimmerman.  
 Zweifach & Wiesenfeld, 126 Bleecker St.; men's, boys' and children's.

**New Orleans.**

Cohn, Joseph & Sons.  
 Buyer: H. Cohn.  
 New York office, 588 Broadway.  
 Fraenekel, Max, 426 Canal St.  
 Frelich & Badt, 220 Decatur St.  
 Godchaux, Leon, Clothing Co., 527 Chartres St.; men's and boys' clothing.  
 New York office, Hackett, Carhart & Co., 422 Broadway.  
 Gordon, I., 605-607 S. Rampart St.; pants.  
 Imperial Mfg. Co. (Ltd.), 218 Chartres St.  
 New York office, 60 Lipsenard St.  
 Israel Mayer & Co.  
 Kory, A. & Sons, 210 Decatur St. and 211 Clinton St.; pants. (Also at St. Louis.)  
 Buyer: Max A. Kory.  
 Lazard, C, Co; general line.  
 Buyers: J. C. Lazard, E. Capdan.  
 New York office, 99 Franklin St.  
 Mercier's, D., Sons, Dauphin, corner Bienville St.  
 Buyer: J. A. Mercler.  
 Nick, H. L. & Co.; general line.  
 Parlongue, Henry.  
 Picard, Kaiser & Co., 210 Chartres St.  
 N. Y. office, 195 Mercer St.  
 Rosenthal Bros., Canal St.  
 Simon & Co., 240 Chartres St.  
 Sternberg & Stern, Chartres and Pontre Sts.; pants.  
 Weil, Leopold, 118 Chartres St.  
 Werner Bros., 233 Decatur St.  
 Wolf, B. J. & Sons; jean clothing.  
 Buyer: A. J. Wolf.

Wolf, Marks & Co., 12 Magazine St.  
 Buyers: M. A. Marks, S. Lowenberg.  
 New York office, 582 Broadway.

### Philadelphia.

- Abrahams & Co., S., 26 N. Fourth St.  
 Adler, L. & Co., 32 N. Third St.; children's clothing.  
 Allen, W. & T., & Co., 718 Market St.; men's wear.  
 Buyers: W. Allen and T. Allen.  
 Arnold, Lochheim & Co., 1021 Filbert St.; general line.  
 Buyer: M. Lochheim.  
 Arnold & Daniel Co, 1021 Filbert St.  
 Bacharach, M., & Co, 533 Market St; men's overcoats and suits.  
 Buyer: M. Bacharach.  
 Baras & Rice, 322 Market St.; general line.  
 Blumberg & Wegman, 36 N. 3d St.  
 Blumenthal Bros. & Co, 48 North 3rd St; children's clothing.  
 Buyer: Herman Blumenthal.  
 New York office, 705 Broadway.  
 Brook & Leff, 1 Bank St.  
 Buchsbaum, I. & Co., 45 No. 3d St.; general line.  
 Buyer: Mr. Buchsbaum.  
 Cohen & Ettleosen, 25 N. 3d St.; pants.  
 Cohen, Miller & Jacobs, 413 Market St.  
 Daniel & Blumenthal, 55 North Thrd St; pants, etc.  
 Buyer: M. Blumenthal.  
 Detwiler, I. L. & Son, 436 Market St.  
 Buyers: Members of firm.  
 Ellel, Louchheim & Co., 314 Market St.; men's wear.  
 Buyer: Mr. Louchheim.  
 Evans, Geo. & Co, 132 North 5th St; military clothing.  
 Buyer: G. Evans.  
 Fleisher Bros, 513 Market St; general line.  
 Buyer: Penrose Fleisher.  
 New York office, 746 Broadway.  
 Frank Bros. & Co, 51 North 3rd St; men's wear.  
 Buyer: Jacob Frank.  
 Gold, A. & Co., 226 Church St.  
 Goodman Bros., 307 Market St.; general line.  
 Buyer: Harry Goodman.  
 Haas, S. L. & Son, 311 Market St.  
 General line and bicycle clothing. Mr. Haas.  
 Harris, Isaac, & Co, 14 North 3rd St; general line.  
 Buyer: Firm.  
 Hess, L. E. & Co., 19 N. Thrd St.  
 Hexter Bros, 434 Market St; summer clothing.  
 Buyer: Jos. Goldsmith.  
 New York office, 737 Broadway.  
 Hirsch, Frank & Co., 33 North 3d St.; children's and sporting goods.  
 Buyer: M. B. Hirsch.  
 Hirsh, Manko & Co., 504 Market St.  
 Katz, L. & Co., 419 Market St.; pants.  
 Keystone Clothing Mfg. Co, 222 Market St.  
 Kirschbaum, Ab. & Co., 726 Market St.; general line.  
 Men's wear, Mr. May.  
 Children's, Mr. Selig.  
 New York office, 754 Broadway.  
 Kohn, Tichner, Myers & Co., 49 N. 3d St.; general line.  
 Buyer: Mr. Ticknor.

Lang, Morris, 327 Market St; general line.  
 Buyer: Morris Lang.

Langer, Meyer, 6 N. Third St.

Lees, David & Co, 334 Market St.

Lisberger & Wise, 335 Market St; pants.

Buyers: Mr. Wise and Mr. Lisberger.

Liverright, Greenwald & Co, 1013 Market St; general line.

Buyer: Mr. Greenwald.

Louchheim, Joseph, & Co., 314 Market St.

Manning, A. M., 403 Market St.; shirts.

Meyers & Liberman, 12 North 3rd St.

Miller & Pleet, 10 N. 3d St.; woolen goods.

Miller, B. F. & Co., 233 Church St.

Miller, Jacob, Sons & Co., 926-930 Market St.; shirts.

Moldawer, M. & Sons, 336 Market St.

Netter, Joseph, Sons & Co, 33 North 3rd St; general line.

Buyer: Jos. Netter.

Ritch, M. & Co., 238 Market St.

Schoeneman & Salsburg, 57 N. Third St.

Sellg, B. & Co, 28 North 3rd St; children's wear.

Buyer: B. Sellg.

Snellenburg, N. & Co., 12th and Market Sts.; general line.

Buyers: Mr. N. Snellenberg and Mr. Nathanson.

New York office, 801 Broadway.

Snyder, Harris, Bassett & Co. (Inc.), 525 Market St; general line.

Buyer: Emerson Snyder.

Stamm, S. & Co., 45 N. 3d St.; pants.

Buyers: Members of the firm.

Thomas, Augustus, & Co., 223 Market St.; uniforms.

Thompson, Jacob G., 1028 Filbert St.

Treacy, Morris & Co, 615 Market St; general line.

Buyer: Mr. Morris.

Wilson, S. & Co, 20 North 3rd St; general line.

Buyer: Mr. S. Wilson.

Yates, A. C. & Co., 1300 Chestnut St.; general line.

Buyer: Mr. Chas. Dissel.

Zion, Jos., 5 Strawberry St.; vestings.

### Pittsburg.

Bennett, Joseph & Co., 713 Penn Ave.; pants.

Goldsmith, Jos., Feiss Co., The (see Cleveland).

Klee's, Jos. Sons, 113 Wood St.; pants.

Buyer: Simon J. Klee.

New York office, 86 Franklin St.

Klee, W. B. & Co, 811 Liberty St; general line.

Buyer: W. B. Klee.  
 New York office, 22 Lafayette Pl.

Lehman & Kingsbaker, 646 Liberty St; general line.

Buyers: Both members.  
 New York office, 577 Broadway.

Oppenheimer, M. & Co, 811 Penn Ave; general line.

Buyer: Mr. Oppenheimer.

Rosenberg, Jacob & Co., 716 Fifth Ave.; pants.

Teplitz, S., 632 Fifth Ave.; pants.

Zugsmith & Finegold; pants.

Buyer: L. Finegold.

**Rochester.**

Adler, L., Bros. & Co., 92 N. St. Paul St.; general line.  
 Buyers: A. Adler, S. Adler and J. J. Barkrow.

Bingswanger, Max Co., 38 St. Paul St.

Black & Meyer, 124-130 North St. Paul St.; general line.  
 Buyers: L. Black, B. S. Meyer.

Brittenstool, J. A., 151 North St. Paul St.; pants and overcoats.  
 Buyer: J. A. Brittenstool.

Cauffman Bros., 86 N. St. Paul St.; tall-ors' trimmings.  
 Buyer: A. Cauffman.

Dinkelspiel Co., The A., 112 St. Paul St.; men's clothing.

Garson, Meyer & Co; general line.  
 Buyer: Tobey Meyer.  
 New York office, 695 Broadway.

Goldsmith, M. & Sons, 161 N. Clinton Ave.; general line.

Goldstein, R. & Co, N. St. Paul and Andrews Sts; men's fine clothing.

Goldwater, N. & Bros., 132 N. St. Paul St.; pants and overalls.  
 Buyer: W. N. Goldwater.

Greenberg & Meyer, 51 N. St. Paul St.; general line.  
 Woolens: Mr. M. Meyer.  
 Trimmings: Mr. Greenberg.

Hays, H. A., 162 N. Clinton St.; boys' and children's clothing.

Hershberg & Co., 120 N. St. Paul St.

Hickey & Freeman Co., 84 St. Paul St.

Holtz, Louis, & Sons, 82 North St. Paul St.; general line.  
 Buyers: L. Holtz, M. L. Holtz.  
 New York office, 695 Broadway.

Hummel, S., 127 St. Paul St.; pants.  
 Buyer: S. Hummel.

Knopf, Jas. & Son, 129 North St. Paul St.

Kolb & Son, 139-145 North St. Paul St.; general line.  
 Buyer: Jacob M. Kolb.

Levi, Kern & Co., 186 N. St. Paul St.  
 New York office, 736 Broadway.

Levinson, Norman & Co., 114 North St. Paul St.; pants.  
 Buyer: Mr. Levinson.

Meyer, H. S. & Co., 149-151 North St. Paul St.

Michaels, Stern & Co; general line.  
 Buyers: J. Michaels, M. A. Stern.  
 New York office, 753 Broadway.  
 Chicago office, 227 Fifth Ave.  
 Cleveland office, 121 St. Clair St.

Moore & Beirs, 125 North St. Paul St.; general line.  
 Buyers: L. W. Moore, E. J. Beir.  
 N. Y. office, 744 Broadway.

Nusbaum, M., 86 N. St. Paul St.

Rosenberg Bros. & Co., 184 N. St. Paul St.; general line.  
 Buyer: H. Rosenberg.  
 New York office, 695 Broadway.

Rothschild, B. & Co., 149 N. St. Paul St.  
 Buyer: B. Rothschild.

Sloman & Cohn, 32 N. St. Paul St.

Solomon Bros. & Lempert, 159 St. Paul St.; general line.  
 Buyer: Mr. Solomon.

Spieß, John A., 24 Campbell St.

Steefel, Strauss & Connor, 84 North St. Paul St.; general line.  
 Buyer: J. D. Steefel.

Steinberg, S., N. St. Paul St.

Stein-Bloch Co, The; general line.  
 Buyers: N. Stein, Mr. Bloch.  
 New York office, 718 Broadway.

Stern, Herman, 112 St. Paul St; general line.  
 Buyer: H. Stern.

Tichner & Jacobi, St. Paul and Andrew Sts.

Utz & Dunn; gaiters, cloth shoe tops, etc.  
 Buyers: Both members.

**San Francisco.**

Alexander Bros., 20 Sansome St.; pants and vests.

Belasco & Harris Co., 541 Market St.  
 New York office, 598 Broadway.

Brown Bros. & Co. (See New York.)

Goldstone Bros., 118 Battery St.  
 Buyers: J. Goldstone, L. Goldstone.  
 New York office, 258 Church St.

Greenberg, P. & Co.

Greenebaum, Weil & Michaels.  
 Buyers: L. Michels, G. H. Gerwin, M. Greenebaum, L. Weil.  
 N. Y. office, 43 Leonard St.

Hastings Clothing Co.

Heynemann & Co.  
 Buyers: M. H. Heynemann, A. Eloesser.  
 New York office, 43 Leonard St.

Hillp, Henry, 102 Battery St.

Hoffman, Rothschild & Co. (See New York.)

Lowenberg & Co., 24 Sansome St.  
 Buyer: A. J. Lowenberg.  
 New York office, 115 Worth St.

Mandel, Pursch & Wiener.  
 Buyer: S. Pursch.  
 New York office, 131 Mercer St.

Meyerstein Co., Bush and Battery Sts.  
 Buyer: L. Meyerstein.

Neustadter Bros., Sansome and Pine Sts.  
 Buyer: I. Oppenheimer.  
 New York office, 23 Thomas St.

Wood, S. N., & Co. (See New York.)

**St. Louis.**

Baer, Oliver, Singer Clothing Co., 717-719 Washington St.; general line.  
 Buyer: A. Baer.  
 New York office, 10 White St.

Blumenfeld, Martin & Bros., 819-821 Washington Ave.; general line.  
 Buyer: Martin Blumenfeld.

Bohm Bros.' Furnishing Goods Co., 1228-1230 Washington Ave.

Cohn, A. & Co., 716 So. Broadway; general line.

Epstein, I. J. & I. Co., 620 N. Seventh St.; pants, etc.

Fraley, Jacob, & Co, 707 Washington Ave.

Gilmore & Ruhl, 619 N. Eighth St.  
 General line, Mr. Gilmore.

Haas, A. & Son, 1106 Washington Ave; general line.  
 Buyer: F. S. Bach.

Hamilton & Sugden Mfg. Co, 1133 Collins St.

Hargadine-McKittrick, D. G. Co., 911 Washington Ave.

Harris, I. & Co., 1128-1130 Washington Ave.; general line.  
 Buyer: D. M. Harris.

Kaminer Joseph, 921-929 North Sixth St.; pants.  
 Buyer: J. Kaminer.

Kory, A. & Son, 816 Lucas Ave.; general line. (Also at New Orleans.)  
 Buyer: M. A. Kory.

Lightner Jumper & Overall Mfg. Co., 207 Morgan St.

Lippman, J. M., 919A North Seventh St.  
Loth-Jeans Clothing Co, 914 Pine St; general line.

Buyer: Jacob Loth.

Maguire, J. M. & Co., 704 Washington Ave; boys'.

Marx-Haas Clothing Co., 1300 Washington Ave.; general line.

Buyer: Harry Marx.

Mills & Averill, Broadway and Pine St.  
Premium Mfg. Co, 1008 St. Charles St.

Rosentreter, M. & Co., 624 Washington Ave.; general line.

Buyer: M. Rosenstreter.

Rosenthal & Desberger, 810 Lucas Ave.; general line.

Buyer: A. Rosenthal.  
N. Y. office, 504 Broadway.

Russack, L. & Sons, 712-714 Lucas Ave.; jeans and staple clothing.

Buyer: S. J. Russack.

Schmitz & Schroder, 501 N. Sixth St.; general line.

Buyers: B. Schmitz, S. W. Schroeder.

Schwab Clothing Co., 1132 Washington Ave.; general line.

Buyers: I. Schwab, L. J. Schwab.

Sigfried, J., 804 North Seventh St.; tailor-made pants.

Spiro Clothing Co, 616 St. Charles St.

St. Louis Pants Co., 717 Lucas St.; general line pants.

Buyer: A. Katz.

Union Clothing Mfg. Co., 82 Lucas St.

Woolf, Geo., & Son & Co., 615 N. 8th St.

### St. Paul.

Guiterman Bros., 350 Silbey St.

Buyer: L. A. Guiterman.

Friend Bros.' Clothing Co., see Milwaukee.

Finch, Young & McConville, 4th and Silbey Sts.; pants.

Buyer: St. T. Sharp and M. J. Boyle.  
N. Y. office, 43 Leonard St.

Lindehes, Warner & Schurmeier, 4th and Silbey Sts.; pants.

Buyer: H. Warner.  
N. Y. office, 51 Leonard St.

Minnesota Tailoring Co., 22-30 West Sixth St.; general line.

Buyer: Henry W. Ley.

Sternberg & Gottschall; pants.

Buyer: L. A. Gottschall.

Sternberg, Weil & Co., 342 Jackson St.; pants.

Buyer: S. H. Weil.

### Syracuse.

Danzlger Bros., 218 East Washington St.; general line.

Buyer: I. Danzlger.  
New York office, 59 White St.

Freeman, Geo. & Co., 220-224 E. Washington St.; overcoats.

Buyer: William Joel.

Friedlander Bros.

Gais Bros., 225 Walton St.; knee pants.

Buyer: R. Gais.

Harrison & Rossman, 106 S. State St.

Kearney Bros, 113-117 East Washington St.; men's, boys' and children's clothes.

Buyers: J. J. and W. H. Kearney.

Kent & Miller, 130-134 South Salina St; general line.

Buyer: A. V. Miller.

Mertens, J. M. & Co, Salina St; general line.

Buyer: J. M. Mertens.

New York office, 36 Thomas St.

Buyer: Geo. H. Dallon.

Peck, W. S. & Co, West Water St; general line.

Buyer: H. R. Peck. (Branch offices at Chicago and Baltimore.)

Peters, N. & Co, Pond and Lodl Sts; general line.

Spencer Clothing Co., 324 West Fayette St.; general line.

Buyer: L. R. Spencer.

Syracuse Clothing Co., 246 W. Fayette St.

Syracuse Dry Goods Co.; pants.

Buyer: G. B. William.

Webber, A. W; general line.

Webber, A. W., 444 S. Clinton St.; general line.

Buyer: A. W. Webber.

Weeks, Chas. E. S.; general line.

Buyer: C. E. Weeks.

Woodhull, Goodale & Bull, cor. W. Willow and N. Clinton Sts.; general line.

Buyer: W. H. Woodhull.

### Toledo.

Shaw & Sassmann.

### Utica.

Calder, John F., 15-17 Whitesboro St.; general line.

Buyer: J. F. Calder.

Crouse & Brandegee; general line.

Buyers: E. D. Brandegee, J. E. Carberry, Geo. H. Dallon.

New York office, 60 Leonard St.

Cooper, H. H. & Co, 33-37 John St; general line.

Buyer: H. H. Cooper.

Mitchell & Thomas, 34 Genesee St.; general line.

Buyer: W. W. Mitchell.

Pixley, H. D. & Son, 9 John St.; general line.

Buyer: G. W. Pixley.  
New York office, 338 Broadway.

Riverside Mfg. Co., 3-5 Meadow St.; overalls for jobbers.

New York office, 43 Leonard St.

Roberts-Wicks Co., The, 18 Catharine St.; men's clothing.

Woolens: R. H. Wicks.  
Trimmings: W. E. McCrea.

Utica Clothing Co., 10 Catharine St.

Buyer: Lewis J. Small.

### Miscellaneous.

Alliance, Ohio. Alliance Pants Co; pants and overalls.

Buyer: Mr. Henry.

Atchison, Kansas, Frank Howard Mfg. Co.

Woolens, J. C. Fox.  
Tailors' trimming, M. Bennett.

Cadiz, Ohio. Brown Bros; pants.

Chattanooga, Tenn. Chattanooga Pants Factory, Geisman Bros. & Bissinger, 722-724 Cherry St; pants, overalls, shirts.

Columbus, Ga. Georgia Mfg. Co; general line.

Buyer: C. L. Perkins.

Columbus, Ga. Peacock, G. J, Clothing Co; general line.

Buyer: G. J. Peacock.

- Columbus, Ga. Rothschild, David & Co.; general line.
- Denver, Col. Underhill Mfg. Co., The, Market and 18th Sts.; men's working clothes.  
Buyer: Charles Bayly.
- Ionia, Mich. Michigan Clothing Co.; general line cloth.  
Buyer: T. B. Preston.
- Janesville, Wis. Janesville Clothing Co., 17-19 S. Main St.; overalls, pants, shirts.  
Buyer: Jos. Weber, Jr.
- Jefferson City, Mo. Star Clothing Mfg. Co.
- Lebanon, N. H. Carter & Churchill, 3 and 5 Parkhurst St.; shirts and overalls.  
Buyer: W. S. Carter.
- Mayfield, Ky. Mayfield Pants Co.; pants.
- Mobile, Ala. Lichtbach Bros, 1-3-5 Dauphin St.; pants.  
Buyer: J. Lichtbach.
- Morristown, N. J. Rosebear Bros. & Co.; pants and overalls.  
Buyer: Mr. Rosevear.
- New Canaan, Conn. Rockwell Bros; men's and boys' suits and pants.
- New Canaan, Conn. Rogers, H. B. & Co; boys' and children's wear.  
Buyer: H. B. Rogers.
- Newton, Iowa. Taylor & Newell Co.; pants.
- Seranton, Pa. Theodore White Mfg. Co., The; shirts and overalls.
- Shippensburg, Pa. Shippensburg Mfg. Co.
- Sloux City, Iowa. Baker, H. A. 815-817 Fourth St; pants, shirts and overalls.
- South Boston, Va. Stebbins, Lawson & Spragins Co.  
New York office, Watson Building, (Room 76), 256 Church St.
- Streator, Ill. Stauber, A., Mfg. Co.; pants, summer clothing.  
Buyers: A. Stauber and C. Stauber.
- Troy, N. Y. Tlm & Co; shirts, etc.
- Woburn, Mass. Richardson, A. L. & Bro; 429 Main St; shirts, overalls and pants.  
Buyer: A. L. Richardson.
- Youngstown, Ohio. Moyer Bros, 113 Commerce St.

## SUIT AND CLOAK MANUFACTURERS.

In the principal cities, buying from first hands.

### Baltimore.

- Baltimore Cloak Co, 314 West Baltimore St; cloakings.  
Buyer: S. W. Cohen and S. L. Cohen.
- Kahn, Leon, 121 West Baltimore St.  
Buyer: Leon Kahn.
- Keene, L., & Co., 26 Hanover St.; cloakings, suits.  
Buyer: L. Keene.
- Lehman & Co., 121 N. Eutaw St.
- Levy, D., & Sons, 107 Hanover St.
- Simon, L., & Co., 310 West German St.; cloaks.
- Stern, Albert, & Co., 28 South Paca St.; cloaks.
- Uilman Cloak & Suit Co., 114 W. Lexington St.
- Weinberg Cloak Co., 4 S. Eutaw St.; cloaks.

### Boston.

- Auerbach, E. & Co, 19 1-2 Beach St; ladies' cloaks, suits, skirts, and children's dresses.
- Becker, G. W., & Co., 173 Summer St.; children's suits.
- Diehl, E. W. & Co., 16 Columbia St.; ladies' skirts.
- Gerber, Benj., & Co., 13 Otis St.; skirts.
- Globe Skirt Mfg. Co., 13 Cooper St.
- Lebow, H. A. & Co, 9 Hayward Place; ladies' cloaks and suits.
- Rudy, Joseph, 535 Washington St.; ladies' skirts, waists and suitings.

### Chicago.

- Anisfield, John, Co., 180 State St.; cloaks.
- Awner & Stern, 254 Market St.; shirts and capes.  
Buyers: Messrs. Awner, Stern and Wohl.
- Badger Mfg. Co., 78 Monroe St.; cloaks.
- Bergman Bros., 242-244 Market St.; capes and skirts.  
Buyer: N. Bergman.
- Blumberg Mfg. Co., 116 Market St.; boys' waists.
- Buckingham Bros. & Co., 275 Franklin St.; cloaks.
- Danziger Bros., 271 Madison St.; cloaks.
- Dernburg Mfg. Co., 220 Adams St.; ladies' skirts.  
Buyer: C. Dernburg.
- DuBroek Mfg. Co., 271 Madison St.; shirt waists.
- Eastern Cloak Co., 481-483 S. Halsted St.  
Buyer: S. Abrahamson.
- Feuer, Ignatz, 898 Milwaukee Ave.; cloaks.
- Griswold, Browning & Co., 173 Adams St  
Grossman, Edward B. & Co., 172 State St.; cloaks.  
New York office, 3-5 W. 3rd St.
- Handmacher & Friedman, 240 Market St.; cloaks.
- Heilprin, L. & Co., 243 Adams St.  
Buyers: Louis Heilprin, H. Jacobs.
- Hirsch, I. & Co., 155 Van Buren St.; cloaks.
- Jacobson, Michael, 24 North Ave.; cloaks.
- Jonas Ladies' Tailoring Co., 126 State St.

Klafter & Bayer, 1307 Milwaukee Ave.; cloaks.  
 Lovett, Matthew R., 259 Madison St.; shirt waists.  
 Lyons & Neuman, 256 Market St.; cloaks. (successors to Edelbroch, Lyons & Co.)  
 Marcus Solms & Son, 220-222 E. Madison St.; suits and skirts.  
 Buyer: Solms Marcus.  
 Mergentheim, Aaron B., 175 Dearborn St.; ladies' waists.  
 Palmer, Percival B. & Co, 197-199 Adams St.; cloaks, suits, laces, etc.  
 Buyer: P. B. Palmer.  
 Rosenfeld, L., 648 W. 12th St.; cloaks.  
 Samson & Jacobs, 230 Fifth Ave.; cloaks, suits and skirts.  
 Schlesinger, Moritz, 3601 Vincennes; cloaks and shirtwaists.  
 Schreibman & Rosenberg, 481 S. Halsted St.; cloaks.  
 Schwartz & Kiine, 231 Monroe St.; skirts.  
 Stuffer, E. A. & Co., 248 Market St.  
 Buyer: E. A. Stuffer.  
 Taylor, M. & S., 167 Aberdeen St.; cloaks.  
 Weiner, Degginger & Aarons, 242 Market St.; cloaks.  
 Wilensky, Abraham, 491 S. Halsted St.; cloaks.

### Cincinnati.

Haas, B. & A., Third & Elm Sts.; ladies' misses' and children's cloaking and suitings, shawls and dress goods.  
 Buyer: A. Haas.  
 The Cincinnati Cloak & Suit Co., 312 Race St.  
 Buyer: H. S. Livingston.

### Cleveland.

Black, H. & Co., 46-50 Bank St.; cloakings, etc.  
 Buyers: G. L. Kaupnan, M. A. Black.  
 Landesman, Hirsheimer Co., 90 Water St.; cloakings.  
 Buyer: Mr. Ben Lowenstein.  
 Prince, Wolf & Co., 272 St. Clair St.; cloaks.  
 Printz, Biederman & Co., 164 St. Clair St.; cloakings.  
 Buyer: Mr. Printz.  
 Sampliner, A. W. & J., 16 Lake St.; cloakings, etc.  
 Buyer: Mr. Sampliner.  
 Schaffer, Levy & Co., 6 Lake St.; cloaks.  
 Stein, Schwarz, Ifuebschman & Co., 270 St. Clair St.  
 Buyer: I. Stein.  
 Sunshine Cloak & Suit Co., 24 Lake St.; cloakings, etc.  
 Buyers: C. K. Sunshine.

### Decatur, Ill.

Decatur Coffin Co.  
 Chas. R. Murphy, buyer; buy silks, dress goods and woollens for cloaks and suits.

### Milwaukee.

Sidenberg & Hays, 351 E. Water St.; cloakings, etc.  
 Buyer: P. Sidenberg.  
 New York office, 49 Mercer St.

### New York.

Alley & Cohn, 23 Washington Place.  
 American Cloak & Suit Co., 63 E. 8th St.  
 Arlington Cloak Co., 55 Walker St.  
 Aronson Bros, 89 Grand St.  
 Aronson, Mark, 5, 7, 9 Union Sq.  
 Buyer: M. Aronson.  
 Asch & Jaeckel, 37 Union Sq.; cloakings, etc.  
 Buyers: Mr. Meyer, Mr. Jelly.  
 Ashman, S., 23 Broadway.  
 Balch, Edward C., 169 Sprng St.  
 Barnett, Louis, 29 E. 10th St.  
 Bates, C. F. & Co, 828 Broadway.  
 Bauman & Sperling, 12 E. 14th St.; cloakings, etc.  
 Buyer: Mr. Sperling.  
 Beifeld, Morris & Co., 715 Broadway.  
 Beller, A. & Co., 125 Fifth Ave.; cloakings.  
 Buyers: Mr. Beller, Mr. Meyer.  
 Benjamin & Caspary, 727 Broadway; cloakings, etc.  
 Buyer: Mr. Lewinson.  
 Berger, Edward, 110 Bleecker St.  
 Bergmann, S., 67 Fourth Ave.  
 Berkowitz, M. A., 357 Canal St.  
 Bernstein & Meyers, 47 Division St.  
 Bernstein, H., 86-94 Canal St.  
 Bernstein, M., 17 E Broadway.  
 Bliss, George N. & Co., 762 Broadway.  
 Block, J., 38 White St.  
 Bloom, Louis & Co., 81 University Place.  
 Bloom, W. & Co., 41 East Broadway; cloakings and suits.  
 Buyer: W. Bloom.  
 Bluestein & Lauman, 699 Broadway.  
 Blum Bros, 828 Broadway, also Philadelphia; cloaks, suits and silk waists.  
 Blum, Gustave & Bros., 40 E. 14th St.; cloakings, etc.  
 Buyer: G. Blum.  
 Blum, H. & E., 106 Division St.  
 Blumenthal Bros. & Co, 3rd and Mercer Sts.; cloakings, etc.  
 Buyers: Mr. G. Blumenthal, Mr. Eisenstein.  
 Blumenthal, J., 116 Prince St.  
 Boskowitz & Davis, 85 Spring St.  
 Boston Cloak Co., 80 4th Ave.  
 Brady, J. M. & Co., 745 Broadway.  
 Brener, L., 194 Greene St.  
 Brody, N. & Co., 75 Greene St.  
 Trimmings, Louis Isaacs.  
 Cloths, Woolens, N. Brody.  
 Brookman, S., 163 Greene St.  
 Brous, Philip, 8 E. 14th St.  
 Brownold & Moskowitz, 60 University Pl.  
 Carton, A. B. & Co., 829 Broadway.  
 Chauser, L., 89 Mercer St.  
 Cohen & Berman, 65 Division St.  
 Buyers: Both members.  
 Cohen, J., 840 Broadway.  
 Cohen, Jacob, 269 Grand St.  
 Cohen, J. H. 81 East Broadway.  
 Cohen, M. & Co., 46 East 14th St.; cloaks.  
 Buyers: Firm.  
 Cohn & Friedman, 31 Walker St.; cloaks.  
 Cohn, J. & Co., 101 Bleecker St.  
 Buyer: M. J. Cohn.  
 Conhain & Co., 60 East 11th St.  
 Corn Meyer, 35 East 12th St.; cloakings  
 Buyer: Mr. Corn.



- Crawford & Quigley, 548 Broadway.  
 Cystryn, Joseph, 362 Madison St.  
 Danzig, H., & Co., 14-16 Waverly Place.  
 Davis, A., 112 Division St.; cloaks.  
 Deutsch, E. & Co., 684 Broadway.  
 Deutsch, Eva, 39 East 12th St.  
 Diack Cloak & Suit Co, The; 39 E. 12th St.; cloakings, etc.  
 Buyer: Wm. Diack.  
 Diamondston, M. & Co., 39 W. 4th St.  
 Dorf, M., 86 Division St.; cloaks.  
 Drusin & Bro., 52 Lispenard St.  
 Duberstein, N., 1-3 Walker St.; cloaks.  
 Eckhardt, J. H., 353 Canal St.; cloaks.  
 Edelman Bros., 84 University Place; children's suits.  
 Ehrlich & Holzner, 721 Broadway.  
 Empire Cloak & Suit Co, 18 Waverly Pl. Woolens, etc, M. Silberman.  
 Trimmings, etc, J. Silberman.  
 Epstein, Jacob, 50-52 West 3rd St.  
 Etkin & Dettelbach, 7 W. 3d St.  
 Ettinger, Lewis, 54 West 3d St.  
 Fagenson, D. J. & Co., 66 Greene St.  
 Fashion Cloak & Suit Co., The, 67 Bleecker St.  
 Fashion Mfg. Co., 209 Greene St.; suits and silk waists.  
 Fein, Samuel, 324 Canal St. and 43 Lispenard St.  
 Feldman & Rothstein, 208 Greene St.; cloaks.  
 Fellerman, A. 58 Division St.  
 Felsenheld, L., 63 E. 8th St.  
 Fischman, Wm., 14 Washington Pl.  
 Folkoff, Sam'l H., 101 Wooster St.  
 Fox, M. & Co., 40 East 12th St.  
 Frey, Chas. D. & Co., 56 East 11th St.  
 Friedlander, A. & Co., 3 Bond St.; cloakings, etc.  
 Buyer: Mr. Gatz.  
 Friedman & Rosenthal, 839 Broadway.  
 Friedrich, L., 24 W. 4th St.  
 Gans, Myer, Sons & Co., 151 Spring St.; cloaks and suits.  
 Buyer: M. Gaus.  
 Geffen, M. L. & Bro., 269 Canal St.; skirts.  
 Gelbwaks, E., 21 Washington Pl.; cloaks.  
 Gershel, H. & Son, 23 West 4th St; cloakings, etc.  
 Buyer: Mr. Abe Gershel.  
 Gllroy & Bloomfield, 17 West 3rd St.  
 Ginsburg, S. & Bro., 22 Lispenard St.; cloaks.  
 Gitskey & Bastianelli, 31 W. 15th St.; children's clothing.  
 Goldberg, J., 21 Washington Pl.; cloaks.  
 Goldberg, M., & Sons, 17-19 W. 4th St.; cloaks.  
 Goldsmith Bros., 39 E. 13th St.  
 Goldstein, Geo. J., 105 Bleecker St.; cloaks.  
 Goldstein & Kernor, 31 East 10th St.; cloaks.  
 Goldstein & Strachstein, 139 Spring St.  
 Graner, Louis & Co., 66 East 11th St.; cloakings, etc.  
 Buyer: L. Graner.  
 Griessman Bros., 729 Broadway.  
 Buyers: Both members.  
 Grunauer Bros., 791 Broadway; skirts and suits.  
 Heller, Dinkelspeil & Co., 822 Broadway; cloakings.  
 Buyer: Mr. Heller.  
 Hellman & Meister, 33 East 10th St.  
 Hendelman & Lippman, 204-206 Greene St.  
 Henigson, Samuel, 138 Canal St.; cloaks.  
 Hepner Bros., 42 Division St.; cloaks.  
 Herrmann, K., 222-224 Greene St.  
 Honeyman & Co, 43 East 12th St; cloakings, etc.  
 Buyer: Mr. Honeyman.  
 Howitt, Thomas & Sons, 20 East 17th St.; cloaks.  
 Igliek, L., 28 Waverly Place.  
 Indig, Max & Co., 718-720 Broadway; cloakings, etc.  
 Buyer: Mr. Schwartz.  
 Jacobson & Winkelmann Co., 17 Washington Place; skirts.  
 Jaulus, Albert, 513 Broadway.  
 Jonasson, Meyer & Co., 817 Broadway; cloakings, etc.  
 Buyer: Mr. Lehberger.  
 Kahn & Altman, 43 East 12th St.  
 Kaminsky, I., 133 Greene St.; cloaks.  
 Kaplan & Liberman, 67 Broadway; cloaks and skirts.  
 Kaplan Bros., 60 E. 10th St.; cloaks.  
 Kaplan, H., 59 East Broadway.  
 Kashowitz, Max & Bro., 22 Washington Place.  
 Kasse, M. & Bros., 24 Wooster St.  
 Kitzinger & Zelenko, 64 East 11th St.  
 Laird, Bonwit & Levy, 36 East 14th St.  
 Lapidus Cloak Co., 737 Broadway.  
 Lebowitz, I., 21 Washington Place.  
 Ledman, Samuel, 346 Canal St.; cloaks.  
 Buyer: Firm.  
 Levett & Schoen, 23 Washington Place; cloaks.  
 Levin, S. & Son, 49 Division St.; cloaks.  
 Levine, B., 27 Division St.; cloaks.  
 Levy, Benjamin, 115-117 Spring St.  
 Levy, Benno, 17 Division St.; cloaks.  
 Levy, Bernard, & Co., 29 W. 4th St.  
 Levy, Herman & Co, 810 Broadway; cloakings, etc.  
 Lewinson & Block, 25 West Houston St.  
 Littenberg, Sol, 307-311 Canal St.  
 Maloney, J. T. & Co., 208 W. 14th St.; wrappers.  
 Mandel, Louis, 43 East 12th St.  
 Mann & Schroeder, 42 East 12th St.  
 Markowitz, H., 17 Waverly Pl.  
 Meadow Bros, 441 Broadway.  
 Miskend, S. H & Co, 92 Division St.  
 Model Mfg. Co., 540 Broadway.  
 Montrose & Casper, 175 Greene St.  
 Nagelsmith & Greenfield, 42 East 12th St.; cloaks.  
 Neadel, H., 94 Prince St.; cloaks.  
 Neugass Bros., 576 Broadway; children's caps and reefers.  
 Newman & Block, 49½ Division St.; cloaks.  
 November, M., 20 East 17th St.; ladies' skirts.  
 Obermeyer, C., 96 Grene St.; cloaks.  
 Buyer: Firm.  
 Oppenheim, Collins & Co., 921 Broadway. cloakings, etc.  
 Buyer: Mr. Oppenheim.  
 Pasternak B. & Co, 133-135 Greene St.

- Peller Bros, 734 Broadway; ladies' cloaks and suits.  
Buyer: Piece goods, Isaac Peller.
- Pellman, Louis & Bro., 124 Canal St.; cloaks.
- Pearlstein, M. & Co., 12 Washington Pl.
- Popkin, A. & Co., Fifth Ave. & 14th St.; cloakings.  
Buyer: A. Popkin.
- Post, Samuel, 35 East 12th St.
- Potosky, Dinkelspiel & Wildberg, 707 Broadway.
- Prince, Wolf & Co., 11-13 Waverly Place. (see factory at Cleveland.)
- Reibstein, E., 100 E. Broadway; cloaks.
- Remer, Samuel, 5 East Broadway; cloaks.
- Rose, Carl L., 5 West 14th St.; cloaks.
- Roseff, Samuel, 37 West 3rd St.
- Rosen & Co., 53 E. 10th St.
- Rosenbaum, Carl, & Co, 725 Broadway; ladies' cloaking.  
Buyer: C. Rosenbaum.
- Rosenberger & Co, 22 West 4th St.
- Rosenfeld, L. E. & Co., 37 East 12th St.  
Buyer: Mr. Rosenfeld.
- Rosengarten & Rosen, 208 Greene St.
- Rosenheim, I., 31-33 East 10th St.; cloaks.
- Rosenthal, F., 308 Canal St.; cloaks.
- Rosenthal, S. & Co., 62 East 10th St.; cloaks and suits.  
Buyer: S. Rosenthal.
- Rothschild, S. & Bro., 7 Union Sq. W.  
Buyer: M. Rothschild.
- Rothschild, M. & L. F., 25 Waverly Pl; misses' and children's cloakings.  
Buyer: Mr. Rosenberg.
- Rubel, Wile & Co., 37 East 12th St.; cloaks.  
Buyers: Mr. Rubel, Mr. Wile.
- Rubin, M., 38 Division St.; cloaks.
- Rubin Bros. & Barron, 127 Bleecker St.
- Sadowsky, R., 304 Canal St.
- Salomon & Klapper, 828 Broadway.
- Samuels, A., 34 East 10th St.
- Samuels, Peter, 25 W. Houston St.
- Samuelson, Jacob, 50 East 10th St.
- Scheyer, Philip, 80 4th Ave.; cloakings.  
Buyer: P. Scheyer.
- Schiff, M. & Bro, 87 Division St.
- Schlessel, Nathan, 132-134 Greene St.
- Schnee, S, 336 Canal St.
- Shaff & Silberman, 83 Canal St.  
Buyer: Mr. Silberman.
- Siegel, Goldberg & Co, 79 Mercer St.
- Siegel, R. & Son, 41 Chrystie St.
- Silver, M. & Co., 99 Bleecker St.; cloaks.  
Buyer: Mr. Silver.
- Simon & Epstein, 149 E. Broadway.
- Simon & Ragovin, 99 Division St.
- Simon, A., 48 E. Broadway.
- Slater, A. M. & Bro., 199 Greene St.; children's cloaks.
- Slater, J. P. & Bro., 154 Wooster St.; plush capes.  
Buyer: J. P. Slater.
- Slatkin, H., 106 Greene St.
- Smith, R. & Co., 583 Broadway; cloaks.
- Spiegel, J. & Co., 13 E. 16th St.
- Steger, Chas., 83 Spring St.
- Stein, Julius, & Co, 104 Bleecker St; ladies' cloaks and suits.  
Buyer: Julius Stein.
- Steinfeld, S. & Co, 558 Broadway.
- Stern & Adler, 631 Broadway; ladies' and misses' cloaks.
- Stern & Guthman, 9 Washington Pl; cloaks.
- Stern & Lebenstein, 592-594 Broadway; cloaks.  
Buyers: Both members.
- Stern, David, & Co., 621 Broadway; shlrt waists.
- Stern, S. & M., 54 East 9th St.
- Stiglitz, Sulzberger & Goldstone, 636 Broadway.
- Stratton, J. C. & Co, 7 and 9 Waverly Pl; misses' and children's cloaks.  
Buyer: J. C. Stratton.
- Syndicate Cloak & Suit Co., 43 E. 12th St.
- Ullman, I, 314 Canal St.
- Vessell, Meyer, 41 Division St.; cloaks.  
Buyer: M. Vessell. Wednesdays only.
- Warner, R. W. & Co., 35 E. 10th St.; cloaks.
- Weltman, Pollack & Co., 121 Spring St.
- Wendorff, H. & Co, 9 East Broadway.
- Werbsa & Kushner, 107 Prince St.
- Wightman & Co., Greene St. and 21 Waverly Pl; women's suits.  
Woolens, W. F. Wightman.  
Buttons, trimmings, etc, F. C. Wightman.  
Dress goods, John Finchney.
- Zalss, Werbsa & Co., 769 Broadway.
- Zimmerman, H. & Co., 29 Eldridge St.

---

### Philadelphia.

---

- Bailey, Lewis L. & Co, 507 Market St; cloakings.  
Buyer: L. L. Bailey.
- Blum Bros., 1005 Market St.; cloakings and silk for waists.  
Buyer: Gabriel Blum.  
New York office, 828 Broadway.
- Canaday, Poulshock & Goldblum, 7th and Market Sts.
- Cantor's Sons, 605 Arch St.
- Caplan, A. H. & Co, 706 Arch St.
- Cohn Bros., 721 Arch St.
- Elkish & Plonsky, 1315 Market St.; cloakings, etc.; children's reefers and coats.
- Fleegler, S., 532 Arch St.
- Frank, H. N. & Co., 1007 Market St.; cloaks.
- Heyman Bros. & Baum, 925 Arch St; cloakings, etc.
- Kauffmann & Bowers, 133 N. 12th St.; cloakings.  
Buyer: Mr. Kaufman.
- Lichtschein & Hofkin, 619 Arch St.
- Marks, I. L., 1015 Filbert St.
- Meyerhoff, M. S. & Co., 816 Cherry St.; cloaks.
- Mock & Tanguay, 125 N. Fourth St.
- Philadelphia Cloak & Suit Co., 129-135 N. Twelfth St.
- Sachs Bros., 1215 Market St.
- Smukler, H, 730 Arch St.
- Star Novelty Co., 919 Walnut St.; ladies' waists.
- Stern, Harry F. & Co., 919 Walnut St.
- Weiss, A. & Co, 923 Arch St.
- Werthelmer Bros., 1315 Market St.; cloakings, etc.

**San Francisco.**

Greenwald & Behan.  
 Messager, E.  
 Meyer Bros.

**St. Louis.**

Bry & Bro. Cloak Co., 1001 Lukas Ave.  
 New York office, 10 White St.  
 Ferguson-McKinney, D. G. Co., 10th St.  
 and Washington Ave.  
 Friedman, N. & J., Eighth St. and  
 Lukas Ave.; cloaks.

Herzog, Morris, Broadway and St.  
 Charles St.  
 Buyer: Morris Herzog.  
 Hughes, John & Co., 909 Lucas St.;  
 cloaks.  
 Buyer: Mr. Hughes.  
 Kurlander Cloak Co., 818 Lucas St.  
 Rosenfield, A., Shirt Waist Co., 1204  
 Washington Ave.  
 Singer Bros., 903 Lucas Ave.  
 St. Louis Cloak Mfg. Co., 704 Washington  
 Ave.  
 Buyer: P. Mullarkey.  
 St. Louis Embroidery Co., 1408 Dodler St.  
 Stix, Albert I. & Co., 1014 Washington  
 Ave.; cloaks.

**Single "Interlock" Machine**

(Trade Mark.)

**FOR OVEREDGING,  
 HEMMING AND  
 SEAMING.**

**Especially Adapted to  
 UNDERWEAR  
 AND HOSIERY.**

*Class 12900.*

**Elastic  
 Seam,  
 Hem or  
 Edge  
 Finish.  
 —  
 High  
 Speed.**

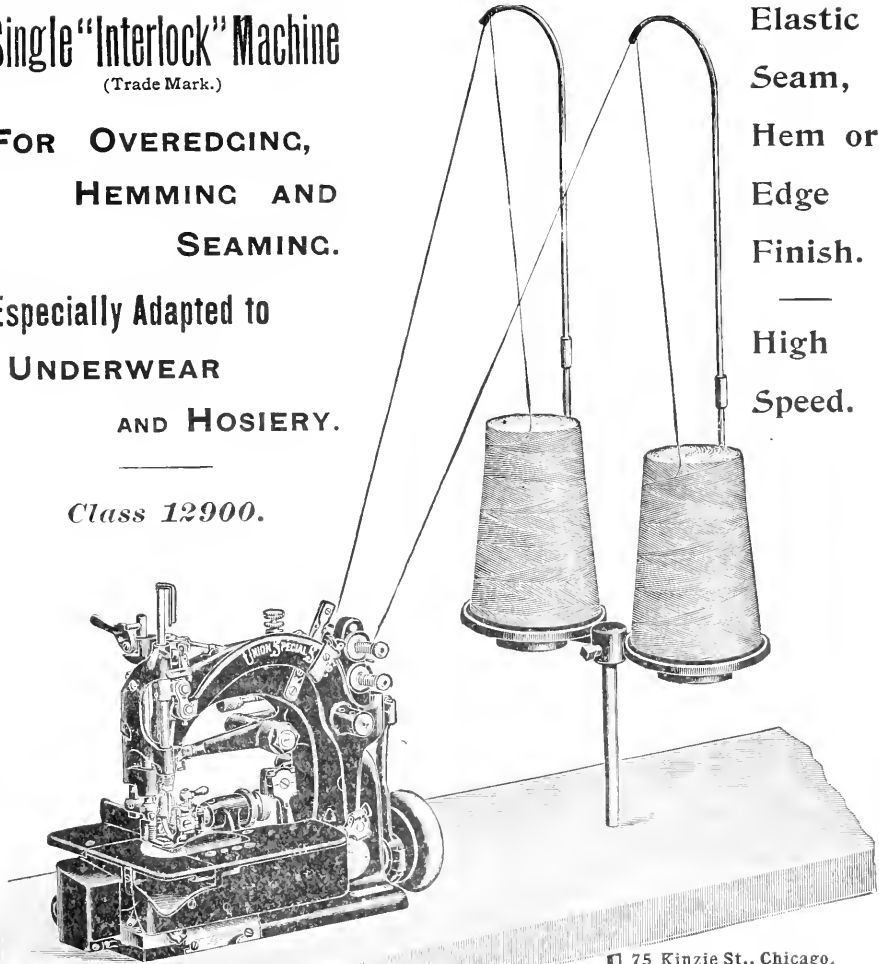

**Union Special Sewing Machine Co.**

- 75 Kinzie St., Chicago.
- 47 Leonard St., New York.
- 228 Market St., Phila.
- 96 South St., Boston.
- 12 Church St., Amsterdam,  
 N. Y.
- 60 Mohawk St., Cohoes, N. Y.
- 708 Main St., Cincinnati.
- 1230 Olive St., St. Louis.

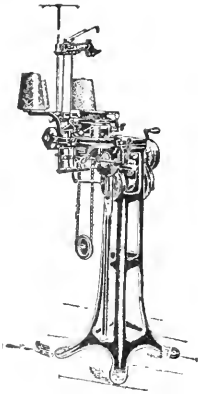

## H. BRINTON & CO.,

213-215 Race Street,  
Philadelphia, Pa.

BUILDERS OF

Full Automatic  
Seamless  
and  
Ribbed

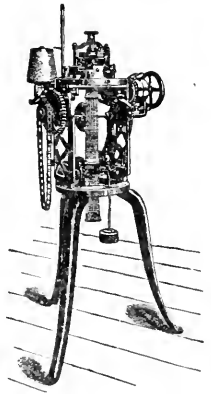

### Knitting Machinery.

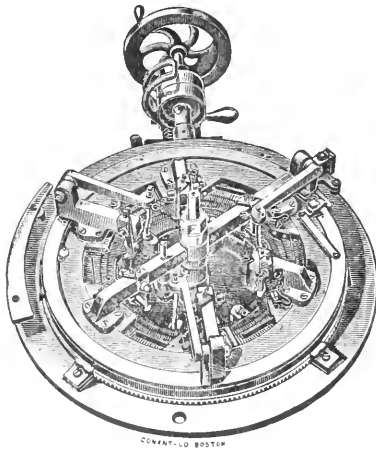

## CIRCULAR KNITTING MACHINES

Either plain or full, automatic, with stop motion complete, for

**RIBBED UNDERWEAR.  
SWEATERS,  
CARDIGANS,  
CUFFS and ANKLETS.**

The Leighton Circular Machines are the only ones which **Back** or **Shog** the needles for fancy borders; also built for automatic striping; and with from 4 to 16 feeds for underwear.

Leighton Machine Co., Manchester, N. H.

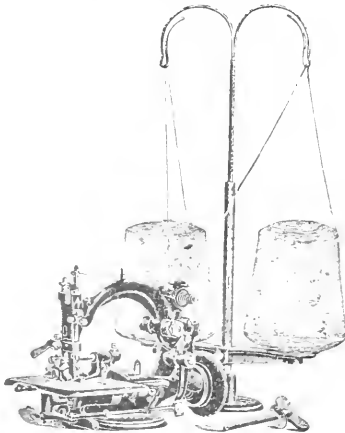

## THE MURPHY

High Speed, Elastic Stitch Sewing Machines for Finishing Knit Underwear and Hosiery.

High Speed, Double Thread Machine, with or without Trimmer, for Knit Underwear.

High Speed, Double Thread, Concealed Welting or Hemming Machine for Hosiery.

High Speed, Single Thread, Chain Stitch Machine with Hardened Parts.

Also High Speed Overedge Seaming and Welting Machines.

KRUSE & MURPHY MFG. CO.,  
455-457 West 26th Street, NEW YORK

# Edward McCreary,

Cohoes, N. Y.

## Finishing Machinery for Knit Goods

*Napping Machines.*

*Brushing Machines.*

*Cloth Turning Machines.*

*Patent Rib Cutters.*

*Garment Turning Machines.*

*Cloth Winding Machines from Dryers.*

*Double and Single Brushing Machines.*

*Folding Machines for Folding and Winding Cloth.*

*Transmitters for Flat or Round Belts.*

*Flat or Grooved Split Pulleys.*

McCreary's Patent Napping Machine is Adapted for Napping all Kinds of Fabrics.

Circulars with Illustrations of all Machines forwarded on application.

## SWEET & DOYLE,

COHOES, N. Y.,

## KNITTING MILL SUPPLIES.

Press Paper

Latch Needles

Knitters Tools

Spinners Tools

Carders Tools

Yarn Scales

Yarn Reels

Box Trucks

Stamping Ink

Brass Size Stamps

Steel Head Jack Spools

Winder Bobbins

Faller Wire

Dies for Gussets

Raw Hide Mallets

Garment Scales

Scales and Trucks Made to Order for Special Work.

## W. J. Von Buchwald,

120 NO. 7th ST., PHILADELPHIA, PA.

Sole Agent for the

### Murphy High Speed

DOUBLE THREAD,  
ELASTIC STITCH,  
SEAM TRIMMING and  
CONCEALED WELTING

Machine,

FOR HOSIERY AND UNDERWEAR.

Trimmers put on all Makes of Machines.

Correspondence Solicited.

## THE CRAWFORD

HOLLOW STEAM

### Plate Press

For Knit or Woolen Goods.

The most reliable machine of the kind on the market.

Press Papers & Fenders

SPENCE & RIDEOUT,

Successors to

J. J. CRAWFORD & SON,

Nashua, N. H.

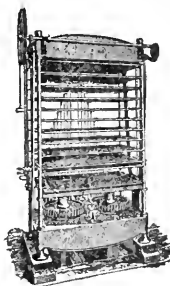

---

# CRANE MFG. CO.

LAKEPORT, N. H.

## SPRING NEEDLE

# Circular Knitting Machinery

For Hosiery, Shirts, Drawers, Jersey Cloth  
and Stockinet.

*A Specialty of Hardened Bladed Burr Wheels with Self-Oiling Brackets.*

---

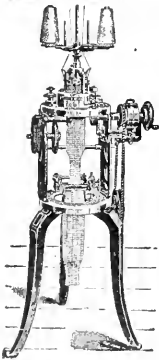

McMICHAEL & WILDMAN MFG. CO.,

# RIB KNITTING MACHINERY.

AUTOMATIC AND PLAIN.

For all classes of Ribbed Hosiery and Underwear, Combination Suits, Sweaters, etc.

ESTABLISHED REPUTATION FOR Largest Production, Best Quality Fabric, Durability, Economy of Operation.

The cut shows our Automatic Sleever and Fancy Hosiery Machine, with Chainless Measuring Attachment. Full particulars, Description and Samples furnished upon application.

NORRISTOWN, PENN.

---

ALL STYLES OF

# RIB KNITTING MACHINERY

OF THE LATEST DESIGN

FOR

Underwear, Sweaters, Hosiery, Etc.

MANUFACTURED BY

**STAFFORD & HOLT, Little Falls, N. H.**

---

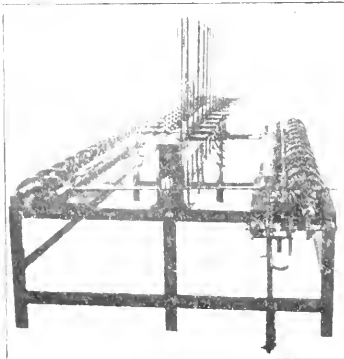

Germantown Hosiery Machine Works.

CARDIGAN JACKET AND Machines

CIRCULAR KNITTING For Shirts and Hosiery.

Cylinder and Dials of all kinds Made and Hardened.

Germantown Skein Winder  
and Links for Double Ribs.

Special Machine and Jobbing Work promptly attended to. Also equipped to do general repairing of Platt's Cotton Spinning Machinery. Correspondence solicited.

**GEO. W. LINDLEY, Prop.**

5122 Wakefield St., Germantown, Pa.

G. W. PAYNE.

Established 1865.

G. M. FANNING.

# GEO. W. PAYNE & CO.,

MACHINISTS AND BUILDERS OF

## Patent Hosiery Winders,

For Hosiery Manufacturers. Winds from Cop, Skein or Bobbin.

OVER 1500 NOW IN USE.

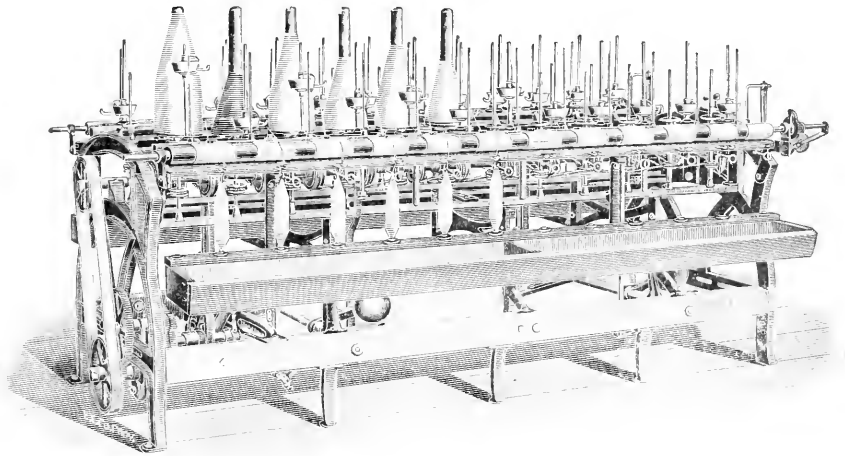

### IMPROVED UPRIGHT SPOOLERS,

TO SPOOL FROM COP, SKEIN OR BOBBIN.

**DOUBLING SPOOLERS,** For doubling two, three or more ends into one. . . .

**UPRIGHT QUILLERS,** Quills from Cop, Skein or Bobbin.

Ring, Dresser, Spooler and Reel Spindles, Cop Skewers, Hosiery Winder Bobbins, Warp Spools, Spooler Guides, Bolsters and Steps Made and Repaired at Short Notice. . . . .

OFFICE:  
106 BROAD ST.,

*Pawtucket, R. I.*

# JAMES TAYLOR,

## Knitting Machinery for Hosiery and Underwear

### New and Second Hand.

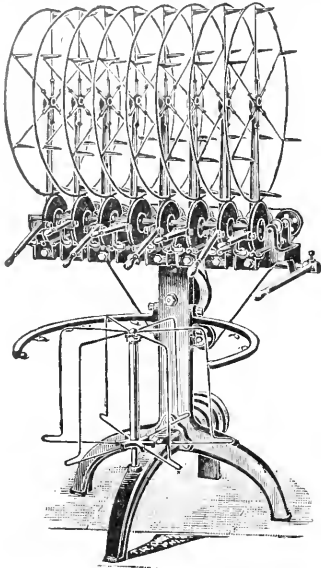

Back-winding Machine for winding the yarn from imperfect pieces back into skeins.

#### SPECIALTIES IN NEW.

Sole Selling Agent for Stafford & Holt.

UNEXCELLED MACHINERY FOR RIBBED UNDERWEAR,

Sweaters, Bathing Suits, Toques and Specialties, with or without Automatic Strippers and Designers.

These machines have the **only absolutely perfect Take-up Device** Depends neither on springs, friction, ratchet, nor state of weather for its efficiency.

Builder of the **ONLY BACK-WINDING MACHINE** in the market. Ravel and backwinds all classes of Knit Goods, including plated work and fabric made on 8-feed plain or tuck machines.

All inquiries and orders relating to the above machines should be addressed direct to me.

#### LARGE STOCK IN SECOND HAND.

Everything pertaining to the manufacture of all classes of Knit Goods, for example: Machines for Ribbed and Flat Underwear Hosiery, Sweaters, Jackets, Mittens, Gloves, Borders, Facing, and Gas Mantles, Button-hole and Button sewing Machines, Concealed Stitch Welters and Trimmers, Union Specials, Steam Presses, Winders, Ribbers, Sleeveless, Loopers, Whizzers, Stop-motions, Cylinders and Dials, Needles, Pins in bulk, Brass Stamps, Stamping Ink, - in short, write us if you are in need of anything, or if you have any Machines for sale.

835 ARCH STREET, PHILADELPHIA, U. S. A.

## STEPHEN S. COOK,

Manufacturer and Dealer in

### *Seamless Knitting*

Machinery  
AND SUPPLIES.

Designer and Builder of

SPECIAL MACHINERY.

624 and 626 Race St., PHILADELPHIA, PA.

Keystone Knitting Machine  
Manufacturing Company.

Manufacturers of Knitting Machine

### NEEDLES

Looper Needles,  
Automatic Knitters,  
Ribbers, etc.

40 North 7th St., Philadelphia, Pa.

## BEATTIE'S MACHINE WORKS,

W. BEATTIE & SON.

### Patent Loopers

With the Patent Raised  
or Straight Points.

COHOES, - N. Y.

## Wm. Breedon's Son,

Manufacturer of

SPRING  
KNITTING  
NEEDLES,

And Burr Blades of All Kinds.

AMSTERDAM, N. Y.



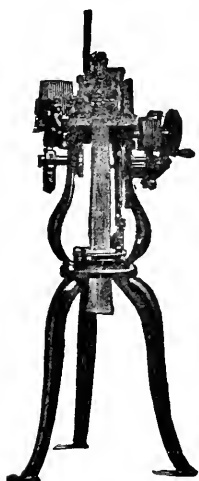

# PEPPER MACHINE WORKS

LAKEPORT, N. H.

Successors to PEPPER MANUFACTURING CO.

MANUFACTURERS OF

## KNITTING MACHINERY,

INCLUDING

Pepper's Flat Ribbed Cuff Machines,

Automatic Welt and Loose Course Machines for Stock Tops. New Circular Strippers with Welt, Loose Course and Striping (Automatic), for Short Cuffs, Sock Tops, Hose Legs, Wristers, etc.

GOLF AND BICYCLE STOCKING MACHINES,

ALL KINDS OF

**CIRCULAR RIBBED MACHINES,**

For Men's Underwear, Ladies' and Misses' Hose Legs and Leggings.

CORRESPONDENCE SOLICITED.

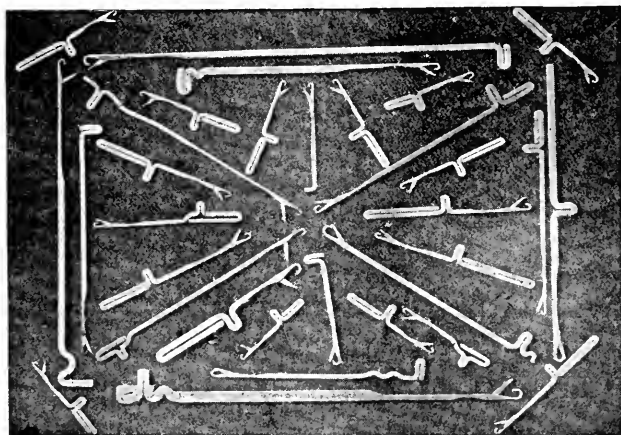

## LATCH

Needles for all

Knitting Machines

OUR

**SUPERIOR**

OR

Sunken Rivet Head  
Needles

will save you money  
every day in the year.

**DODGE NEEDLE CO., Manchester, N. H.**

LOYAL T. IVES,

MANUFACTURER OF ALL KINDS OF

**SPRING KNITTING NEEDLES**

NEW BRUNSWICK, N. J.

## PHILADELPHIA TEXTILE SPECIALTY MACHINE COMPANY,

500 North 12th Street, Philadelphia, Penn.

### Mercerizing Machinery for Skein, Warp and Piece Goods.

TENTERING CLIPS AND CLAMPS OF ALL DESCRIPTIONS.

**Finishing and Special Machinery for the Textile Trade  
designed and built to order.**

When writing for particulars and prices, please mention this magazine.

## AUTOMATIC IRONING AND PRESSING MACHINE FOR KNIT GOODS.

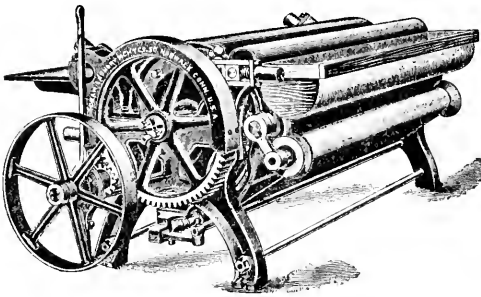

This machine irons and presses ribbed and flat underwear, giving a fine smooth finish and most attractive appearance to the goods, not to be obtained in any other way. It does not break buttons. Inexpensive and easy to operate, and has large capacity. Knitting mills using them are greatly pleased with results. This method of finishing is sure to come into universal use. Send for further particulars to

**J. W. CRAW LAUNDRY MACHINERY CO.,**  
SOUTH NORWALK, CONN.

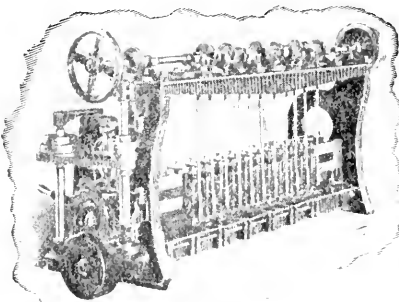

STANDARD HORSE BLANKET MACHINE.

## L. F. FALES,

Manufacturer and Builder of

### Multiple Needle Sewing Machines

For Sewing Carpet Linings,  
Horse Blankets, Wadding, etc.

These machines can be built with  
any required number of needles.

Special Machinery Designed and Built.

Telephone Connection.

**WALPOLE, - MASS.**

**THE BABCOCK & WILCOX Co.**  
 85 LIBERTY ST.  
 NEW YORK  
 CABLE ADDRESS  
 NEW YORK  
 "GLOVEBOXES"  
 ALL FOREIGN OFFICES  
 "BABCOCK"



**WATER TUBE BOILERS**

SEND FOR OUR BOOK "STEAM"

**BOSTON**  
 35 FEDERAL ST.  
**PHILADELPHIA**  
 NORTH AMERICAN BLDG.  
**SAN FRANCISCO**  
 32 FIRST ST.

**BRANCH OFFICES**  
**CHICAGO**  
 MARQUETTE BLDG.  
**NEW ORLEANS**  
 339 CARONDELET ST.  
**PITTSBURGH**  
 EMPIRE BLDG.

**ATLANTA, GA.**  
 EQUITABLE BLDG.  
**MEXICO CITY**  
 CIENEGA BLDG., 7 AVENIDA JUAREZ  
**HAVANA, CUBA**  
 105 CALLE DE LA HAVANA

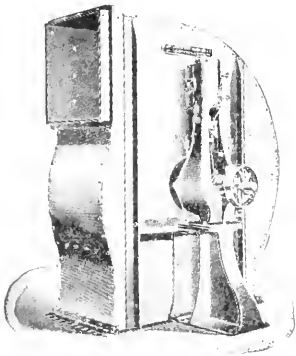

## MECHANICAL DRAFT.

Do you want to save money?

Do you want to make money?

Do you want the best draft?

Do you want the *best mechanical draft apparatus?* If so, you want the

**"HARTFORD" APPARATUS.**

Correspondence solicited.

**THE HARTFORD BLOWER CO.,**

71 Suffield Street, - Hartford, Conn.

## CANVAS AND STEEL FRAME MILL BASKETS

Are replacing all other kind where hard usage is given and where **lightness, strength, durability and cheapness** are a consideration. Some of the comparative results in big mills are remarkable. Send for our booklet. We make all styles and shapes for every kind of mill use.

**W. T. LANE & BRO.,**

Port Chester, N. Y.

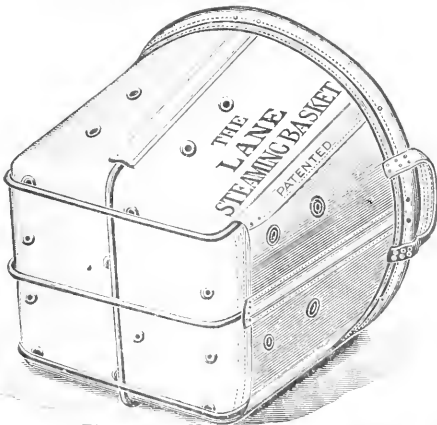

FIG. 23

**RICHARD C. MADDOCK,**  
 Direct Mill Agent, Domestic Hosiery.

Room 906, N. Y. Life Insurance Building, NEW YORK.

839 Market Street, PHILADELPHIA, PA.

# The Textile World

Is the leading journal of the great Textile Industry covering the Cotton, Woolen, Worsted, Knitting, Silk, Flax, and Jute Mills, Dye Works, Print Works, Bleaching and Finishing Establishments in the United States, Canada and Mexico. It is the oldest Textile Journal in the world (established 1868) and has a larger circulation among the mills than any other publication, and by far the largest number of advertisements from textile machinery builders, textile mills, dealers in mill supplies, dyestuff, chemicals, etc.



It furnishes to advertisers to the amount of \$50.00 or more the TEXTILE ADVANCE NEWS, giving them the investigated news of all new textile construction, etc., in most instances before orders are placed.



THE TEXTILE WORLD is published monthly on the 12th of each month.



Copy for advertisements must reach publication office by the 25th of the month preceding date of issue to insure proper attention. Rates on application.

Subscription { \$2.00 per year. { \$3.00 in Foreign Countries. Combination Price for Textile World and Traveler's Edition of this Directory Annually, \$3.00.
--

**Publication Office, Boston, Mass.**

**Branches:**

**New York.**

**Philadelphia.**

# USEFUL BOOKS.

**Weave Lexicon for Harness Weaving.** By Franz Donat, A. Hartleben, Wien. 160 pages; price \$2.00.

This book contains 4100 different diagrams of weaves for the harness loom. The 160 pages contain no reading matter, but are filled with the weave diagrams. It will prove a valuable book to the designer and weaver, who will find here weaves for a vast number of different effects. An inspection of these colored diagrams will prove an inspiration to the designer. He will see here the possibilities of harness weaving and not only find the weaves exactly suited to his needs, but receive suggestions which he can amplify to produce original designs.

**Practical Carder.** By James H. Greer. Price 50 cents.

This book begins with a short description of the cotton plant and fibre, which is followed by chapters on the following subjects: Ginning; Baling; Opening and Mixing; Breakers and Lappers; Carding; Railway Heads; Drawing Frames; Slubbing and Roving Frames; Picking Department; Calculations for Cards, Railway Heads, Drawing Frames, Slubbing and Roving Frames.

It is of a handy size for the pocket, and will be found valuable to all engaged in cotton manufacturing.

**The Students' Cotton Spinning.** By Joseph Nasmith; 593 pages; price \$3.00.

This is a standard work on spinning and treats of the following subjects: Evolution of Cotton Spinning; Varieties of Cotton; Mixing, Opening and Scutching; Carding; Card Clothing and Grinding; Combing and Drawing; Slubbing and Roving; The Theory of Spinning; Mule Spinning; Ring Spinning; Reeling; Winding and the Manufacture of Thread; Waste Spinning; Arrangement of Drafts and Production.

**Science of Colour Mixing.** David Paterson; 124 pages; price \$3.00.

The author of this book, who is a dyer, has treated in a very practical manner the science of mixing ordinary colors and dyes thus producing a work that should be in the hands of every dyer and colorist. There are five colored plates showing the various colors and effects produced by mixing them. The book also contains eleven dyed samples together with recipes.

**Woolen and Worsted Manufacture.** By Robert Beaumont; 356 pages; price \$2.00.

The following is a brief outline of the contents given by chapters: 1, Materials; 2, Woolen Thread Manufacture; 3, Worsted Thread Construction; 4, Yarns and Fancy Threads; 5, Loom-mounting; 6, Principles of Cloth Construction; 7, Hand Looms; 8, Power Looms; 9, Weave Combinations, Drafting; 10, Pattern Design; 11, Color Applied to Twilled and Fancy Weaves; 12, Backed and Double Cloths; 13, Analysis of Cloths and Calculations; 14, Cloth Finishing.

**Practical Cotton Calculations.** Ernest Whitworth; price \$1.00.

This work is a handbook containing a large amount of useful information relating to cotton yarn, cloth structure, loom and miscellaneous cotton mill calculations and written in a clear and concise manner. The author, who is a practical weaver and designer, has in this work sought to give mill men the information that is needed in every-day work and to exclude all matter not essential to this main object. The work is illustrated and contains many useful tables.

**Spinning Woolen and Worsted.** By W. S. B. McLaren; 251 pages; price \$1.50.

This is a very practical work on the spinning of woolen and worsted yarns. The following is an outline of the table of contents: Nature of Wool; Wool Sorting; Wool Washing and Oiling; Difference Between Woolen and Worsted; Preparing and Carding for Combing; Wool Combing; Drawing; Worsted Spinning; Woolen Carding; Feeding, Condensing and Spinning; Twisting, Reeling and scouring.

**Draw Frames and Fly Frames.** By Thomas Thornley; 350 pages; price \$3.00.

This is the only work especially devoted to the drawing and roving processes, and is intended to benefit those who are directly concerned in the practical operation of the machines under discussion, with particular stress on the points which will give the best results from machines in their actual manipulation. Among the subjects treated may be mentioned the following: Drawing Frames; Fly Frames—Winding, Building Motion, Differential Motions; Roller Setting and Drawing; Defective Roving Bobbins; How to Put up Frames; etc.

*Any of the above sent postage paid on receipt of price by*

*GUILD & LORD, 95 South Street, Boston, Mass.*



3 2922 00392 343 7

# FOSTER MACHINE CO.

Latest Cone and Tube

# WINDERS

FOR

Cotton, Woolen, Worsted.

Yarn delivers direct  
from cones to knitting machine  
without rewinding. Patented in  
United States of America and Europe.

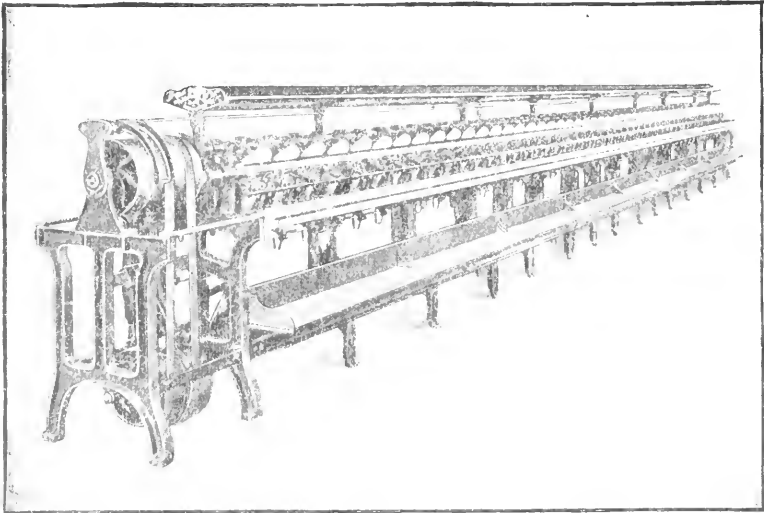

Also Builders of 

Close Winders for Thread, Twine, Linen,  
Jute, Etc.

Write for Catalogue and Estimates.

WESTFIELD, = MASS.

TS1312  
05

1902

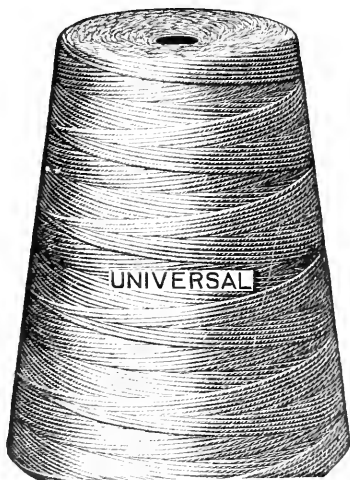

677  
T313  
05

sys

RI

TS1312.05 1902

of

and

L'

I

t

18

LOWELL MACHINE SHOP,  
LOWELL, MASS.  
ESTABLISHED 1845.

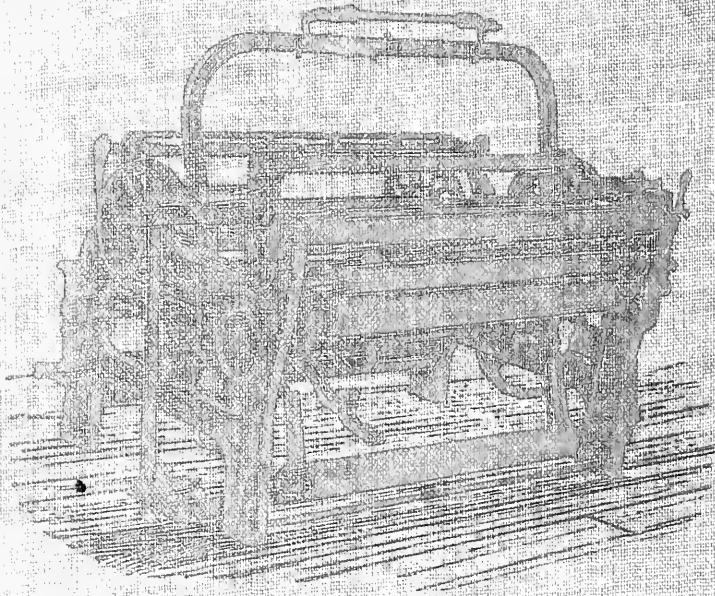

BUILDERS OF

COTTON MACHINERY

OF EVERY DESCRIPTION

SEE PAGE 2, INSIDE.